

123

## VUILLEUMIER CYCLE CRYOCOOLER OPERATING BELOW 8 K

Yoichi Matsubara ✓  
Atomic Energy Research Institute  
Nihon University  
Tokyo 101, Japan

and

Mitsuhiko Kaneko  
Cryogenic Department, Suzuki Shokan Co., Ltd.  
Saitama 362, Japan

This paper describes the design and development of a Vuilleumier cycle cryocooler (VM cooler) operating below 8 K, for the application of small superconducting devices. Liquid nitrogen has been used as a heat sink of the hot displacer. The annular gap between the phenolic displacer and SUS 304 stainless cylinder has been used as a gap regenerator. In order to obtain the cooling temperature below 8 K, we designed a single stage VM cooler which is precooled to 10 K by another two stage VM cooler. The effect of the mean operating pressure, cycle speed and phase difference between the hot and cold displacer of each VM cooler will be also discussed, including the experimental results.

Key words: Cryocoolers; heat exchangers; helium; low temperature; refrigerators; regenerators; Vuilleumier cycle.

### 1. Introduction

The requirement of low-power cryocooler investigation for several electronic devices, such as infrared detectors or superconducting devices, has recently increased. This kind of cooler will be used for long term operation with no maintenance. Closed-cycle cryocoolers using gap-regenerators are suitable for these requirements. Zimmerman and Radebaugh have developed a four-stage split-Stirling cryocooler operating at the temperature of about 8.5 K as a SQUID cooler [1]. Myrtle, et al have also demonstrated operation of a split-Stirling cryocooler at 9 K using a single hollow conical displacer [2]. Sager and Paulson have constructed a four stage Gifford-McMahon cycle which achieved an ultimate temperature of 7.1 K [3].

It seems to be difficult to obtain the temperature of below 5 K with these methods, however, Zimmerman and Sullivan have demonstrated the feasibility of operation at the temperature below 4 K using a Stirling cycle cryocooler with the hot end temperature of near 10 K [4]. In our previous work, a Gifford-McMahon cycle cooler anchoring at 10 K also achieved 4.8 K [5]. These results indicate the choice of a cryogenic cycle and the optimized design of regenerators are important in order to achieve the temperature below 8 K. In this paper, we describe the experimental results of two different types of VM cryocooler.

### 2. Three Stage Vuilleumier Cryocooler

We have built the three stage Vuilleumier cryocooler as a test apparatus. To decrease the mechanical complexity we used liquid nitrogen as a heat rejection stage. A schematic of the VM cooler is shown in figure 1. The expansion and the compression displacers have been driven in sinusoidal motion using a stepping motor with an adjustable eccentric shaft cam. The annular gap between the stainless steel cylinder and the cotton reinforced phenolic displacer was used as a regenerator in each stage. The hot and the three cold displacers were 60, 30, 20, and 10 mm in diameter and about 20 cm in length. The compression part and the expansion part have been operated, respectively, with 15 mm and 20 mm stroke. In the final stage of this cooler, the temperature swing was 7.7 to 8.8 K when the first stage was 33 K and the second was 13 K under the following operating conditions: phase angle of 40 degrees, average pressure of 0.54 MPa, and the

frequency of 70 rpm. Figure 2 shows the cooling capacities at the cold end of this cooler. We have not controlled the quantity of liquid nitrogen flow in its minimum condition, but total LN<sub>2</sub> consumption, including external losses, was 0.5 liter per hour at most.

In order to obtain a lower temperature while reducing the losses in the regenerator, the pressure was decreased. The resulting operation of the cryocooler was not as effective as before. When the phase angle was less than 40 degrees, the temperature difference between the second and final stages increased, despite increasing the temperature of the final stage. We theorized that the changes required an increase in the P-V quantity. To accomplish this it is possible to increase the working mass of the helium gas. However, the losses from the regenerator would simultaneously increase. Another important factor is the second stage temperature. The second stage expansion volume could be increased to optimize the operation when the working pressure is reduced. The cryocooler could be made to produce the same cooling power without increasing the frequency. Consideration of the thermal strain of the thin walled cylinder and the plastic piston during the cool down period shows it is desirable to make the regenerator short. The temperature difference between the warm and the cold end of such a short regenerator must be small in order to reduce the losses in the final stage.

### 3. The Composite VM Cryocooler

The investigation of the coldest section of the composite VM cryocooler is presented here. Figure 3 shows the schematic diagram. This cooler is made of the two stage pre-cooler and the single stage test cooler. These two coolers have the same driving mechanism in which a variable speed stepping motor and two scotch yokes are used. The working space is separated from atmospheric ambience by two small O-ring seals. The physical dimensions are described in Table I.

Table I. Physical Dimensions of Two VM Coolers

	Pre-cooler			Test Cooler	
	Compression	1st Stage Expansion	2nd Stage Expansion	Compression	Expansion
Cylinder O.D.	48	20	14	48	12
Displacer O.D.	46.8	18.8	12.8	46.8	11.4 *
Displacer L.	136	180	180	136	235 *

All values in millimeters

\* - Below pre-cooler 2nd stage (test section)

The test cooler was pre-cooled through a 4 cm width copper band. The radial clearance of the displacer sections were about 0.1 mm. A cotton reinforced phenolic resin rod was used for the displacer. Lead tape 1 mm in width and 0.2 mm thick was wound spirally around the pre-cooler second stage. We used GdRh powder (45 vol. %) with epoxy resin as a regenerative material for the test cooler final stage. The displacer was coated with its material in the thickness of about 0.2 mm.

The pre-cooler was operated without the load of the test cooler. Figure 4 shows its performance under the conditions of 62 degrees in phase angle, 48 rpm and a minimum pressure of 0.25 MPa. The ultimate temperature was 13.4 K. We also obtained about 14 K with the phase angle at about 50 degrees and 65 rpm. Figure 5 shows the test cooler performance with pre-cooler. The minimum pressure of the test cooler was 0.65 MPa and the phase angle was increased by increasing the operating speed until the temperature reached approximately 7 K. This figure shows that the temperature difference of test section is about 11 K under these optimized conditions. It is required to decrease the temperature of pre-cooler 2nd stage in order to obtain the temperature of below 5 K. Table II shows the operating conditions and the results. The temperature swing of the final stage of the test cooler was 5.4 K to 6.5 K without the external heat load. The second stage temperature of the pre-cooler was about 16.1 K with the phase angle of 50 degrees and the minimum pressure of 0.4 MPa. In any other conditions, the temperature of below 16 K was not obtained.

Table II. Test Results of the Composite VM Cooler

I. Pre-cooler

Phase angle: 50 degrees  
Pressure swing: 0.4 MPa to 0.96 MPa  
Operating speed: 60 rpm  
Stroke of the compression displacer: 18 mm  
Stroke of the expansion displacer: 10 mm  
Temperature of the compression part at cold stage: 81 K  
Temperature of the expansion part at 1st stage: 34.4 K  
Temperature of the expansion part at 2nd stage: 16.1 K

II. Test Cooler

Phase angle: 53 degrees  
Pressure swing: 0.155 MPa to 0.34 MPa  
Operating speed: 39 rpm  
Stroke of the compression displacer: 18 mm  
Stroke of the expansion displacer: 5 mm  
Temperature of the expansion part at cold stage: 81.4 K  
Temperature of the expansion part at point 1: 41.2 K  
Temperature of the expansion part at point 2: 16.1 K  
Temperature of the expansion part at cold end: 5.4 to 6.5 K

In order to determine the cooling power which the cooler was producing, we measured simultaneously the warm end pressure and the movement of the displacer with the time axis using a pressure transducer and a linear displacement converter. The P-V diagrams are shown in figures 6 and 7. The pre-cooler produced the cooling power of about 250 mW at the second stage. The test cooler produced the cooling power of about 27 mW at the final stage. The effect of the backlash of a scotch yoke appeared at the top and the bottom end in the figures. We estimate that most of the cooling power produced by the pre-cooler was consumed by the regenerator loss. The amount of heat rejection from the test cooler is estimated to be less than 50 mW.

4. Conclusion

We obtained the ultimate temperature of 5.4 K and about 10 mW at 7 K by using the composite VM cryocooler when the temperature of the pre-cooler was about 16 K. However, there remain many problems to be solved such as the regenerator loss analysis including the effect of dead volume and a specific heat of the regenerative materials, phase angle optimization, and the effect of the non-ideality of the helium properties.

The authors would like to thank Professor K. Sekizawa for providing the GdRh powder. Part of this-work has been supported by the Science and Technology Agency.

5. References

- [1] Zimmerman, J. E., Radebaugh, R., NBS SP-508, Page 59 (1978).
- [2] Myrtle, K., Winter, C., and Gyax, S., Cryogenics, 22, Page 139 (1982).
- [3] Sager, R. E., Paulson, D. N., NASA CP-2287, Page 81 (1983).
- [4] Zimmerman, J. E., Sullivan, D. B., Cryogenics, 19, Page 170-171 (1979).
- [5] Matsubara, Y., Yasukochi, K., NASA CP-2287, Page 157 (1983).

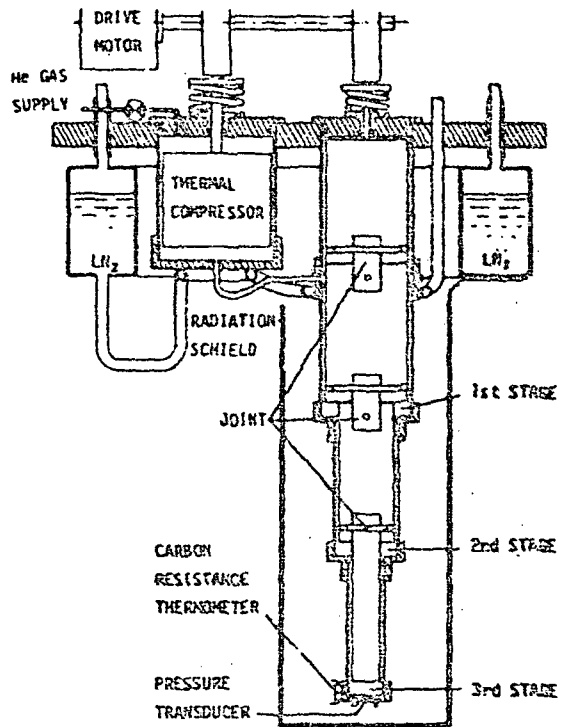

Fig.1. Schematic diagram of three-stage VM cooler

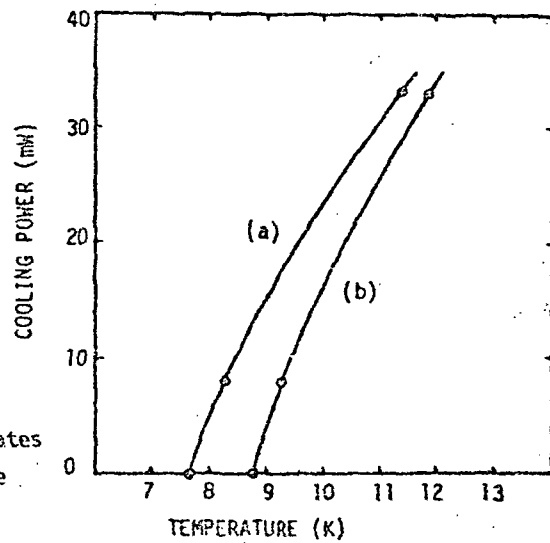

Fig. 2. Three-stage VM cooler cooling capacity of the final stage vs. temperature: (a) and (b) indicates the upper and lower bound of the temperature swing

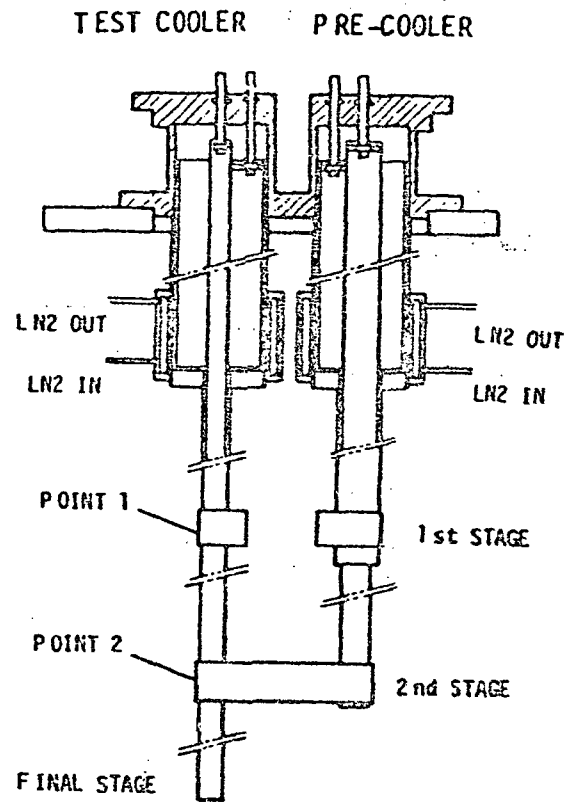

Fig.3. Schematic diagram of the composite VM cooler

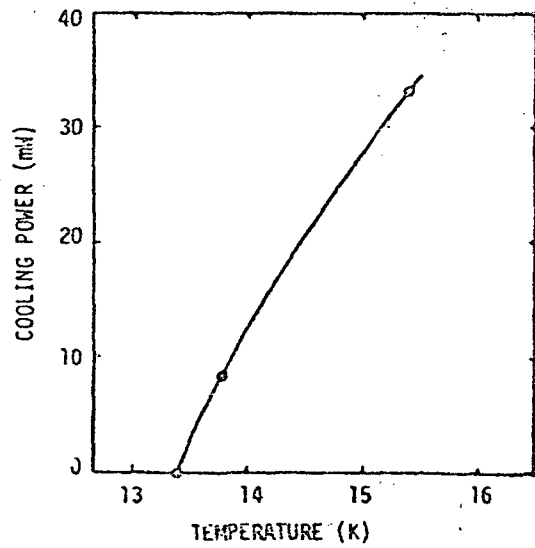

Fig.4. Pre-cooler cooling capacity of the 2nd stage temperature

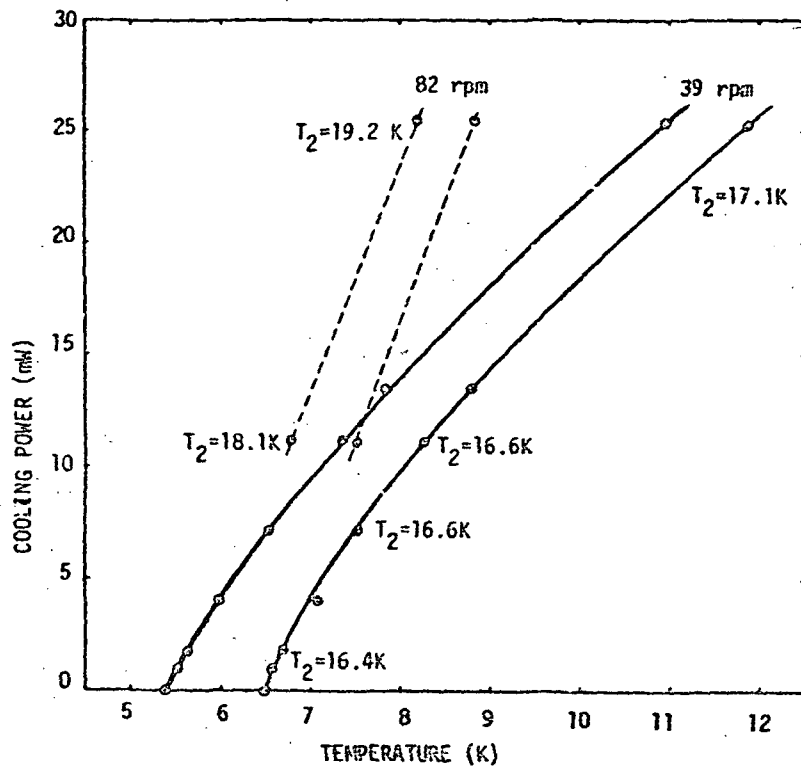

Fig. 5 Test cooler cooling capacity vs temperature  
 ( T<sub>2</sub>: Temperature of the precooler 2nd stage)

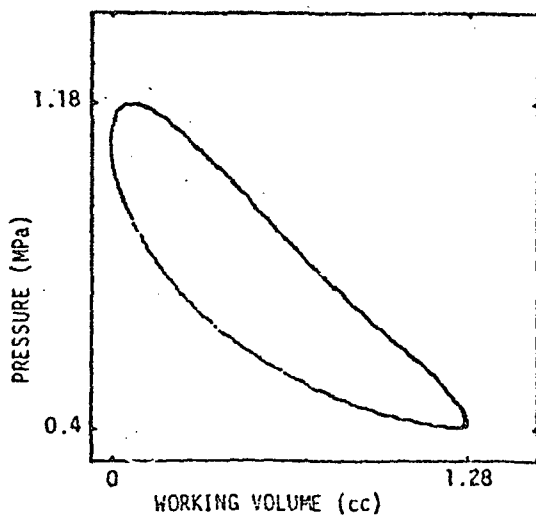

Fig.6. P-V diagram of the 2nd stage of the pre-cooler

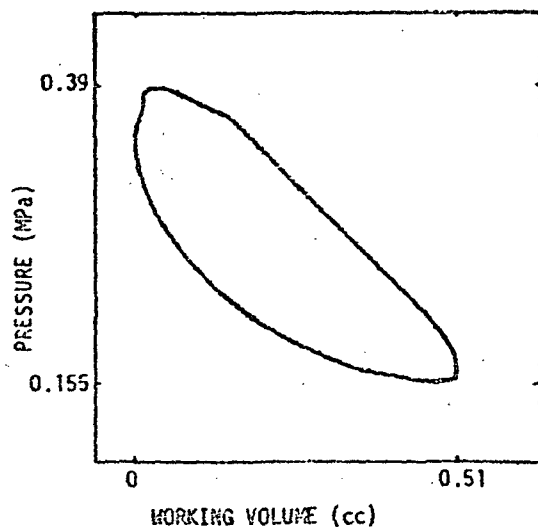

Fig.7. P-V diagram of the final stage of the test cooler