

# Catalytic Surface Effects on Contaminated Space Shuttle Tiles in a Dissociated Nitrogen Stream

Orvel Flowers and David A. Stewart

November 1985

LIBRARY COPY

DEC 12 1985

FOR INFORMATION

LANGLEY RESEARCH CENTER  
LIBRARY, NASA  
HAMPTON, VIRGINIA

NOT TO BE TAKEN FROM THIS BOOK

---

# Catalytic Surface Effects on Contaminated Space Shuttle Tiles in a Dissociated Nitrogen Stream

---

Orvel Flowers,  
David A Stewart, Ames Research Center, Moffett Field, CA

November 1985



National Aeronautics and  
Space Administration

**Ames Research Center**  
Moffett Field California 94035

N86-15335<sup>#</sup>

## SUMMARY

Visual inspection revealed contamination on the surface of tiles removed from the lower section of the Space Shuttle orbiter after the second flight of Columbia (STS-2). Possible sources of this contamination and the effect on surface catalytic activity are presented.

## INTRODUCTION

The Space Shuttle orbiter's thermal protection system (TPS) includes over thirty thousand high-temperature, reusable, surface insulation (HRSI) tiles. These tiles have a reaction-cured glass (RCG) coating that provides thermal control as well as handleability (ref. 1). In addition, the glass coating minimizes the heat load to the vehicle during Earth entry because of its low-surface catalytic efficiency for the recombination of atomic oxygen. Surface catalytic efficiency for this coating has been measured in both arc-jet and microwave-cavity tests in terms of reaction-rate constants (ref. 2). Reaction-rate constants are used in computations to determine surface temperature distributions over various surfaces on the orbiter during Earth entry. The TPS performance is then evaluated by comparing these computations with flight data. However, visual inspection of the coated tiles over the lower surface of the orbiter after the second flight of Columbia (STS-2) revealed possible contamination (discoloration) that could affect the surface catalysis (ref. 3). This paper identifies possible contaminants and evaluates their effect on the coating's surface catalysis.

## TEST APPARATUS

### Thermal Analyzer

A thermal analyzer (thermogravimetric analysis) was used to measure the thermal stability of suspected contamination sources and their degradation products. Weight-loss measurements were made at a fixed rate of temperature rise and over a range of temperatures from 25°C to 1200°C. These tests were conducted in air at 1 atm.

## Microwave Cavity

A sketch of the microwave-cavity test equipment is shown in figure 1. The equipment consisted of a glass tube, 2.54 cm in diameter by 35.5 cm long, with a bleed valve and gas regulator at one end, and vacuum pump and model support at the other end. The Hg-198 microwave cavity was located roughly halfway along the test tube. Test models were installed just downstream of the cavity. A surface thermocouple, installed in contact with the RCG coating, extended from the model's back surface through the support tube to a minicomputer. The support tube was sealed at the minicomputer end.

High-purity nitrogen gas was passed through the evacuated test tube at a constant flow rate. The nitrogen gas was dissociated by resonating it in the microwave cavity at 24.5 MKH. During each test, a constant surface temperature was maintained by regulating the static pressure in the tube and microwave exciter power. Static pressure was measured using a thermocouple vacuum gage connected to a port just upstream of the microwave cavity. Model surface temperature was referenced to room temperature.

## Test Models

Models tested in the microwave cavity were disks. The 1.91-cm-diam. by 1.27-cm-thick disks were bonded to 0.16-cm-thick aluminum base plates, figure 2. The disks were samples cut from HRSI tiles some of which were removed from the lower surface of the orbiter after STS-2. The locations from which these tiles came were near the nose-wheel door, the center and leading edge of the left wing, and the elevon cove on the right wing of the orbiter, figure 3. The identification numbers and description of the tiles are given in table 1. A chromel-alumel thermocouple (0.025 cm) was installed at the center of the disk and in contact with the RCG coating. The thermocouple leads extended beyond the base plate approximately 50 cm to allow for easy connection to the minicomputer.

## Materials

Possible contaminants on the RCG-coated surfaces are sea salt and degradation products from the bonding material for the tile-strain isolation pad, marking paint, and gap-filler coating. Sea-salt contamination was not included in this investigation. Basically, the study was restricted to the degradation products from the materials used as part of the TPS. The bonding material (RTV 560) consisted of a silicone rubber cured at room temperature and filled with iron oxide,  $\text{Fe}_2\text{O}_3$ . A lacquer, cellulose-nitrate marking paint used to identify the tiles is described in federal specification yellow 13538. The paint composition is given in table 2. The major pigment is medium chrome yellow ( $\text{PbCrO}_4$ ) and the binder is made up of organic materials (e.g., nitrocellulose, alkyd resins, and plasticizers). Finally, the gap fillers are of two types: layers of aluminoborosilicate-glass cloth bonded together with RTV 560 (nose-wheel door) and aluminoborosilicate-glass cloth covered with an emittance coating (between tiles). The emittance coating consists of tetraboron

silicide and glass frit in an RTV 620 binder. Unlike the RTV 560 material the RTV 602 does not have fillers.

## EXPERIMENT

The two tests conducted in this study were: 1) thermal analysis to determine whether contaminants could be released from these materials and redeposited on HRSI tile surfaces downstream of possible contamination sources during an Earth entry of the orbiter and 2) microwave-cavity tests to determine the relative-surface catalytic efficiency of the RCG coatings before and after two Space Shuttle flights.

### Thermal Analysis

Samples of cured RTV 560 and the gap filler with the emittance coating were analyzed. Marking paint was analyzed after being applied wet to a Teflon sheet, allowed to dry, and removed in strips. In addition, samples of lead chromate and lead monoxide, which are used as pigments in the marking paint, were analyzed. All thermal analysis tests were conducted at atmospheric pressure and over a range of temperatures from room temperature to 1200°C.

### Microwave Cavity

Degradation products of the paint were prepared for testing in the microwave cavity by bonding them (in powder form) to the RCG surface of the models. This was done by first wetting the RCG surface with nitrocellulose. Second, powder was sprinkled on the RCG surface so that upon drying an excess amount would be present.

High-purity nitrogen gas (99.99+%) was maintained at a constant flow rate by regulating the static pressure at  $P = 0.002$  N/cm and the power setting at 50% for each test. Before each test, the tube was purged several times with the nitrogen gas. The coated model was exposed to the dissociated nitrogen gas for 10 min. Steady-state test conditions were reached within 3 min. after the nitrogen gas in the microwave cavity was excited. Relative atom recombination for each material was determined from surface temperature measurements. Steady-state temperature from a contaminated surface was ratioed to the surface temperature measured on an uncontaminated RCG coating. Typical ratios of surface temperature for a material with high-surface catalytic efficiency (platinum) to the RCG coating was 1.3 to 1.6.

## RESULTS AND DISCUSSION

Thermogravimetric analysis (TGA) suggests that degradation products from the RTV 560 could be one source of contamination found on the tiles after flight

STS-2. Data obtained from RTV 560 indicated that free  $\text{Fe}_2\text{O}_3$  and  $\text{SiO}_2$  are released at between 500°C and 550°C. Decomposition of the RTV 602, used as a binder in the emittance coating, resulted in oxidation of tetraboron silicide and the formation of a foamed glass and  $\text{SiO}_2$  as shown by a weight loss at 500°C and weight gain at 850°C. The TGA of a dried sample of the marking paint showed weight losses at 200°C, 300°C, and 1000°C (fig. 4). The weight losses at 200°C and 300°C are due to degradation of the binder (nitrocellulose and alkyd resins). The weight loss at 1000°C is probably due to lead monoxide. The TGAs were performed on samples of lead-chromate and lead-monoxide powders to determine their thermal stability (figs. 5 and 6). A TGA of the lead chromate without the binder showed a 7% weight loss at 850°C, which corresponds stoichiometrically with the following reaction:

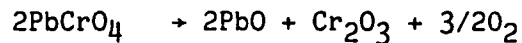

Figure 5 shows that sublimation of lead chromate begins at 950°C. This weight loss is attributed to lead monoxide, which melts at 950°C. A TGA of lead-monoxide powder verified the weight loss to be due to sublimation, figure 6. The thermal stability of possible decomposition products from a lead-chromate compound is listed in table 3. Chromium or chromium oxide from the marking paint would not be expected to be found on the RCG coatings on an orbiter because of their high boiling points. Lead monoxide is the only species available for vapor-phase transport. However, the paint binder burns out below 500°C and frees all species to be transported mechanically over the vehicle surface during Earth entry.

Surface temperature ratios (sample to RCG coating) and reradiation-equilibrium temperature data obtained in the microwave tests from the marking paint and its degradation products are listed in table 4. Included in the table are data from a model with a platinum film and the RCG control sample. The literature reports that the surface catalytic efficiency for the recombination atomic nitrogen is high for platinum and low for the RCG coating (ref. 4). This effect is best illustrated by comparing the accommodation coefficient of the two compounds, Pt,  $\gamma_N = 2.2 \times 10^{-2}$  and RCG,  $\gamma_N = 10^{-4}$ . Therefore, platinum films 100 Å and 1000 Å thick were included in the tests as reference materials with high surface catalysis. The RCG coating was used as a control surface. These data show that the relative-surface catalytic efficiency of lead, lead oxides, and chromium oxide are high and the paint and lead chromate are low, if they are deposited in high enough concentrations. Similarly, surface temperature ratios and reradiation equilibrium temperatures for postflight STS-2 RCG coatings are listed in table 5. Tile identification numbers for each sample are included in the table. These data show that the surface catalytic efficiency (surface-temperature ratio) for the postflight samples are roughly equivalent to an untested RCG coating.

## CONCLUDING REMARKS

All of the thermal degradation products from the lead chromate were shown to have a relatively high-surface catalytic efficiency in a dissociated nitrogen gas. Should these degradation products collect on the HRSI surfaces in sufficient quantities, one would expect to see increased temperatures. However, HRSI tiles that were removed from the orbiter after the STS-2 flight showed no increase in surface catalysis. Therefore, contaminants released from the sources investigated in this study were probably removed by the hot boundary-layer flow over the vehicle's surfaces during the second flight, or were not deposited in sufficient quantity to change the surface catalytic efficiency.

## REFERENCES

1. Goldstein, H. E.; Leiser, D. B.; and Katvala, V.: Reaction Cured Borosilicate Glass Coating for Low-Density Fibrous Silica Insulation. Borate Glasses. Plenum Corp., New York, 1978, pp. 623-634.
2. Stewart, D. A.; Rakich, J. V.; and Lanfranco, M.J.: Catalytic Surface Effects Experiment on Space Shuttle. AIAA Paper 81-1143, 1981.
3. Stewart, D. A.; Rakich, J. V.; and Lanfranco, M. J.: Catalytic Surface Effects on Space Shuttle Thermal Protection System During Earth Entry of Flights STS-2 through STS-5, Shuttle Performance: Lessons Learned. NASA CP-2283, Part 2, 1983.
4. Rosner, D. E.; and Feng, H.: Energy Transfer Effects of Excited Molecule Production by Surface-Catalyzed Atom Recombination. Vol. 70, JSC Faraday I, 1974.



**TABLE 1.- LOCATION OF CONTAMINATED TILES ON SHUTTLE**

TILE ID NUMBER	SHUTTLE LOCATION	TEMPERATURE	CONTAMINATION DESCRIPTION
V070-391035-242	NOSE LANDING- GEAR DOOR	1900°F	DISCOLORED, LETTERING
V070-191007 630	BEHIND MAIN LANDING GEAR	1450°F	DISCOLORED
V070-191008-138	WING	1930°F	DISCOLORED
V070-191025-105	FRONT OF OUTBOARD ELEVON	1700°F	LETTERING

**TABLE 2.- PAINT SPECIFICATIONS**

**FEDERAL SPECIFICATIONS TT-L-32A**

**LACQUER, CELLULOSE NITRATE, GLOSS, AIRCRAFT USE  
ORANGE YELLOW 13538**

**CONTROL FORMULATION (PERCENT BY WEIGHT, DRY)**

MEDIUM CHROME YELLOW	35.7
NITROCELLULOSE 1/2 sec	19.6
ALKYD RESINS	38.2
PLASTICIZERS	6.5

**TABLE 3.- PIGMENT, LEAD CHROMATE**

FORMULA	NAME	F/W	MELTING	BOILING
$PbCrO_4$	LEAD CHROMATE	323	844°C	
POSSIBLE DECOMPOSITION PRODUCTS				
Pb	LEAD	207	328	1740
Cr	CHROMIUM	52	1860	2672
PbO	LEAD MONOXIDE	223	886	
$Pb_3O_4$	RED LEAD	686	500d	
$Cr_2O_3$	CHROMIUM OXIDE	152	2270	4000

TABLE 4.- CATALYCITY OF LEAD-CHROMATE PIGMENT AND THERMAL-DEGRADATION PRODUCTS

SAMPLE SURFACE	RATIO	EQUILIBRIUM TEMP.
RCG CONTROL	1.00	183°C
1000A° PT/RCG	1.33	243°C
ID PAINT/RCG	0.83	152°C
LEAD CHROMATE/RCG	1.12	205°C
PbO/RCG	1.31	240°C
Pb <sub>3</sub> O <sub>4</sub> /RCG	1.21	221°C
Pb/RCG	1.51	277°C
Cr <sub>2</sub> O <sub>3</sub> /RCG	1.27	233°C

TABLE 5.- CATALYCITY OF CONTAMINATED SURFACE VERSUS CONTROL SURFACE

TILE SURFACE	RATIO OF CONTAMINATED - TO CONTROL-SURFACE EQUILIBRIUM TEMPERATURE	EQUILIBRIUM TEMP.
242-1	0.88	162°C
242-2	0.85	158°C
242-3	0.94	175°C
030	0.93	173°C
138	0.97	181°C
105-1	0.94	175°C
105-2	0.94	175°C

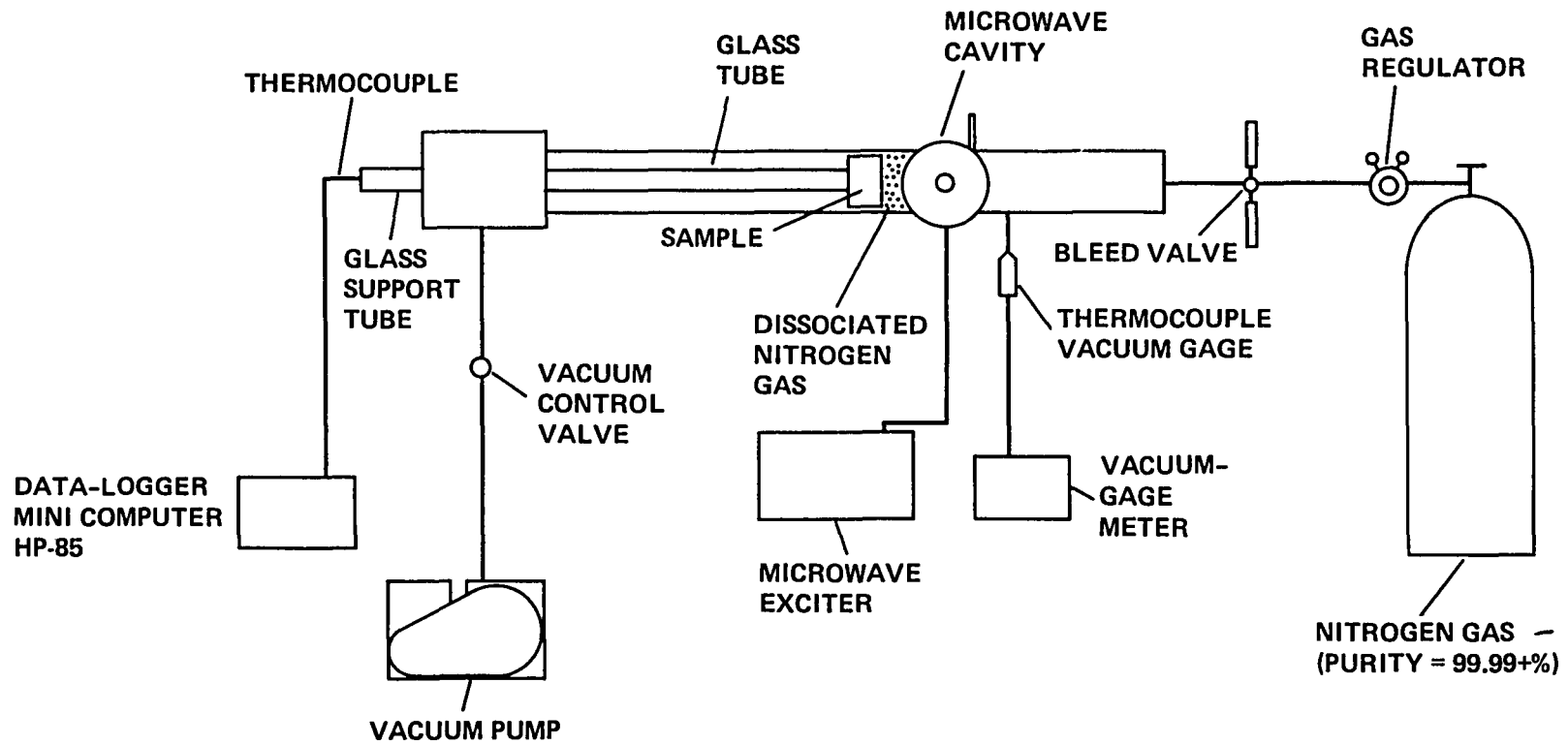

Figure 1.- Microwave-cavity test equipment.

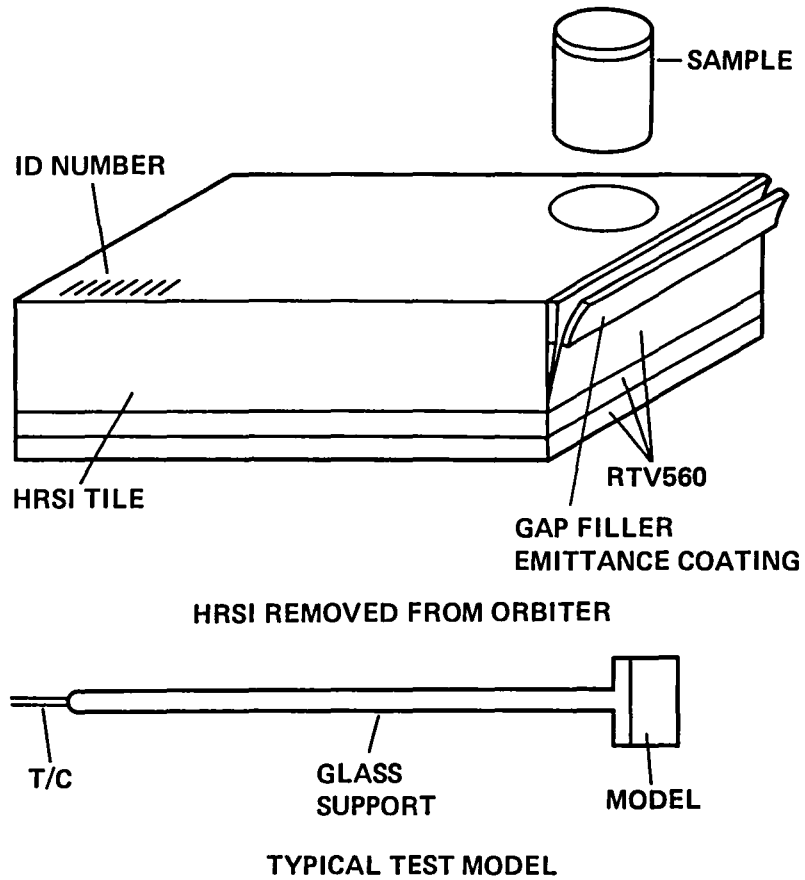

Figure 2.- HRSI tile showing typical cylindrical disk sample mounted as model on microwave-cavity support.

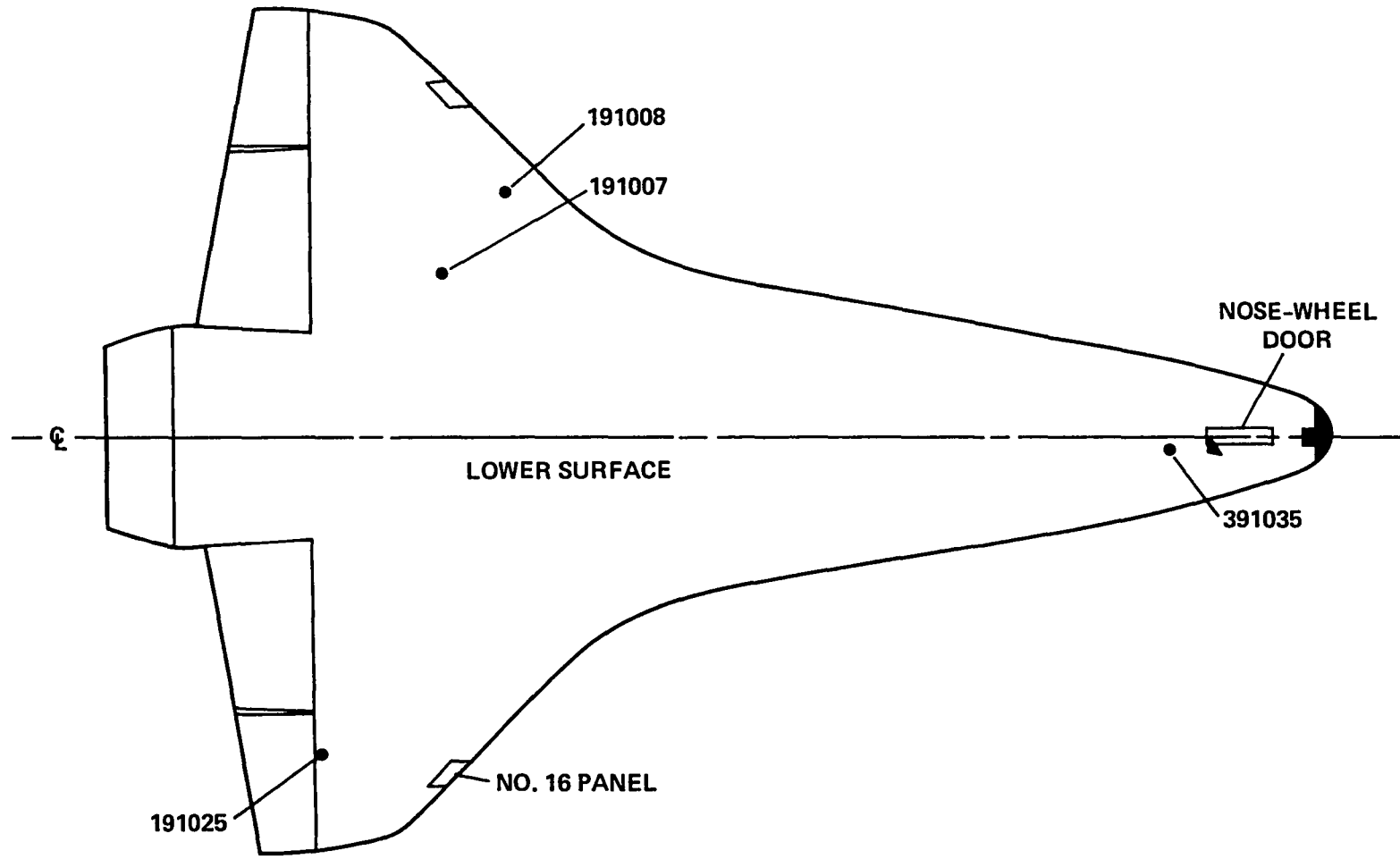

Figure 3.- Orbiter STS-2 showing location of contaminated HRSI tiles removed for testing.

THERMOGRAVIMETRIC ANALYSIS (TGA)  
TILE YELLOW-MARKING PAINT  
LACQUER, CELLULOSE NITRATE, GLOSS, TT-L-32A

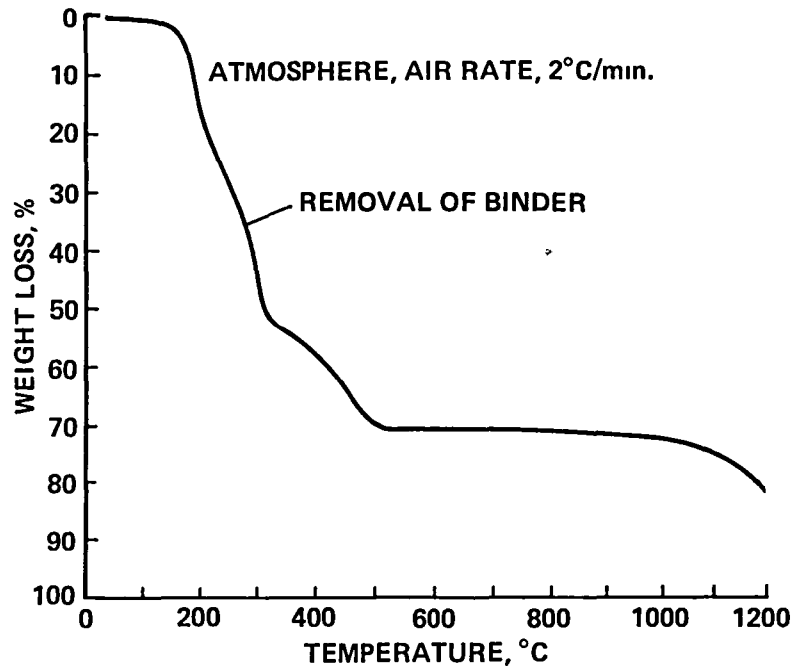
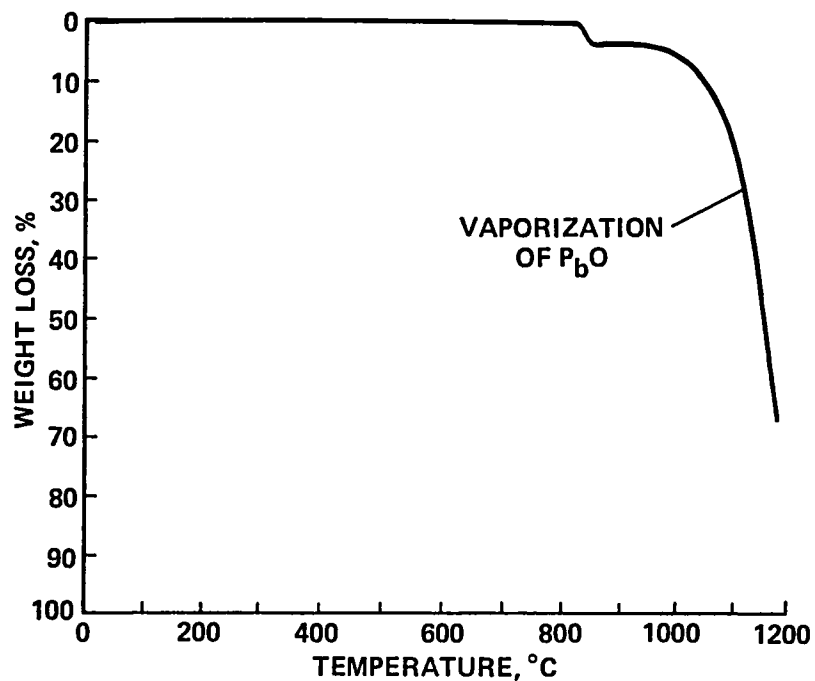

Figure 4.- Weight loss versus temperature thermogram of tile-marking paint.

THERMOGRAVIMETRIC ANALYSIS (TGA)  
LEAD-CHROMATE POWDER ( $PbCrO_4$ )  
ATMOSPHERE, AIR RATE 2°/min



WEIGHT LOSS AT 850° C AGREES WITH  
THE FOLLOWING REACTIONS:

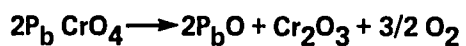

Figure 5.- Weight loss versus temperature thermogram of lead chromate pigment used in tile-marking paint.

THERMOGRAVIMETRIC ANALYSIS (TGA)  
LEAD-MONOXIDE POWDER ( $PbO$ )  
ATMOSPHERE, AIR RATE  $10^\circ/\text{min}$

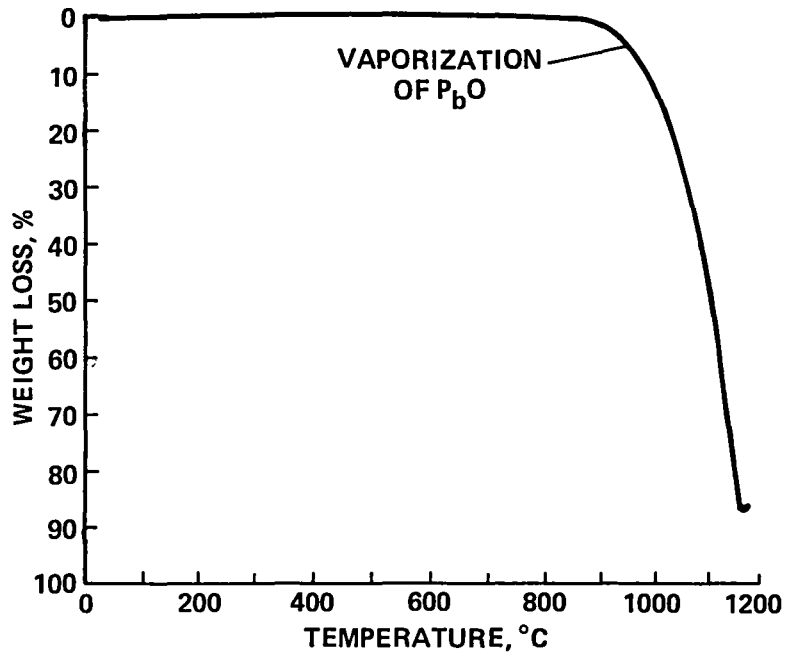

Figure 6.- Weight loss versus temperature thermogram of lead monoxide decomposition product of lead chromate pigment.



1 Report No NASA TM-86770	2 Government Accession No	3 Recipient's Catalog No	
4 Title and Subtitle CATALYTIC SURFACE EFFECTS ON CONTAMINATED SPACE SHUTTLE TILES IN A DISSOCIATED NITROGEN STREAM		5 Report Date November 1985	6 Performing Organization Code
		8 Performing Organization Report No 85328	10 Work Unit No
7 Author(s) Orvel L. Flowers and David A. Stewart		11 Contract or Grant No	
		13 Type of Report and Period Covered Technical Memorandum	
9 Performing Organization Name and Address Ames Research Center Moffett Field, CA 94035		14 Sponsoring Agency Code 506-53-3104	
		12 Sponsoring Agency Name and Address National Aeronautics and Space Administration Washington, DC 20546	
15 Supplementary Notes Point of Contact: Orvel Flowers, Ames Research Center, MS 245-5, Moffett Field, CA 94035 (415) 694-5028 or FTS 464-5028			
16 Abstract  Visual inspection revealed contamination on the surface of tiles removed from the lower section of the Space Shuttle orbiter after the second flight of Columbia (STS-2). Possible sources of this contamination and the effect on surface catalycity are presented.			
17 Key Words (Suggested by Author(s))  Catalycity            Insulation Surface                Tiles Shuttle		18 Distribution Statement  Unlimited  Subject Category - 18	
19 Security Classif (of this report) Unclassified	20 Security Classif (of this page) Unclassified	21 No of Pages 17	22 Price* A02

**End of Document**