

**NASA Technical Memorandum 87625**

**AVSCOM Technical Report 85-B-8**

NASA-TM-87625 19860007143

# **STRESS ANALYSIS OF 27% SCALE MODEL OF AH-64 MAIN ROTOR HUB**

**Robert V. Hodges**

**OCTOBER 1985**

**LIBRARY COPY**

**JAN 13 1985**

LANGLEY RESEARCH CENTER  
LIBRARY, NASA  
HAMPTON, VIRGINIA

**NASA**

National Aeronautics and  
Space Administration

**Langley Research Center**  
Hampton, Virginia 23665





## SYMBOLS

E	Youngs Modulus (psi)
F	force (lb)
FTU	Material ultimate allowable tensile stress
FTY	Material yield allowable tensile stress
M	moment (in-lb)
R	reaction (lb) or radius (in)
RA, RB	strap pack leg reactions (lb)
CF	centrifugal force (lb)
$\beta$	flap angle (degrees)
f	stress (psi)
P	bolt preload (lb)
M.S.	margin of safety
Z	section modulus I/C (in <sup>3</sup> )
A	area (in <sup>2</sup> )
$k_t$	stress concentration factor
L	length (in)
D	bolt diameter (in) or moment arm (in)

### Subscripts:

L/L	Lead/lag
F/F	flap/feather
T	torsional
D1, D2	Damper, radial and transverse directions respectively
L1, L2	Lead/lag link radial and transverse directions respectively
P1, P2, P3	Pitch Case, radial, and transverse and vertical directions respectively

F2, F3 Flap/Feather bearing, transveres and vertical directions respectively

F Flapwise

S2 Strap pack, transverse direction

BI Bolt initial

SI Sleeve Initial

BT Bolt tension bending side

ST Sleeve tension bending side

tol tolerance

REQ required

1, 2, 3 cartesian coordinates where: 3 is the lead lag hinge axis; 1 is perpendicular to 3 and radial; 2 is perpendicular to 3 and transverse.

i strap number (strap pack)

alt alternating

TABLE OF CONTENTS

INTRODUCTION. . . . . 1  
APPROACH. . . . . 2  
LOAD PATHS. . . . . 2  
    Lead/Lag Moment. . . . . 2  
    Centrifugal Force. . . . . 5  
    Torsion. . . . . 6  
    Component Load Summary . . . . . 7  
STRESS ANALYSIS . . . . . 8  
    Lead/Lag Hinge . . . . . 8  
    Pitch Case Clevis at Lead/Lag Hinge . . . . . 12  
    Strap Pack. . . . . 14  
    Hub Shoe . . . . . 18  
CONCLUSIONS . . . . . 21  
APPENDIX A. . . . . 22  
REFERENCES. . . . . 26  
TABLES. . . . . 27  
FIGURES . . . . . 30



## INTRODUCTION

The Aerostructures Directorate (ASTD), NASA Langley Research Center, Hampton, VA as part of the continuing basic research in support of the Army helicopters, built a dynamically scaled model of the AH-64 helicopter rotor hub (fig. 1). This model rotor system is designed for testing in NASA Langley's 4x7 m low-speed wind tunnel. The model will find continued use in future rotorcraft model testing. Hence, its structural integrity must be assured. This paper documents stress analysis for critical components of the rotor hub.

The AH-64 hub is essentially articulated with some rotational stiffness about the lead/lag hinge due to the elastomeric dampers and some centrifugally supported torsional stiffness in the strap pack.

The critical components include the pitch case, the upper hub plate, the strap pack, and the lead/lag hinge pin assembly. The analysis includes both static and fatigue considerations.

## APPROACH

Loads and motions scaled are from AH-64 flight data and supplied by Hughes Helicopter Corporation.

Static load path analysis is presented for the hub components. Loads defined in an unpublished Hughes stress analysis as maximum static are taken to be limit loads. A factor of safety of 1.5 is applied to limit loads to determine ultimate loads.

The hub assembly, with applied blade root loads, is shown in figure 2. These applied loads will be used to determine component loads. Because the component loads are statistically determinate, static analysis will be used. These applied root loads are tracked individually from component to component into the hub plates, stresses are then determined by superposition with all loads considered to be in phase.

## LOAD PATHS

### Lead/Lag Moment

The moment about the lead/lag hinge,  $M_{L/L}$ , is equal to the moment carried by the dampers. The rather complex load path shown in figure 3 will be broken into a series of free bodies. Reference will be made to to this figure throughout the load path section. Figure 4 shows a free body of the lead/lag link with the moment applied. Summation of moments about the hinge yields the '1' direction component of the damper load ( $R_{D1}$ ).

$$R_{D1} = M_{L/L}/2.43 \quad (1)$$



The angle  $6.754^\circ$  of the dampers relative to the 1 axis produces a transverse inplane reaction  $R_{D2}$  where

$$R_{D2}/R_{D1} = \text{TAN } 6.754^\circ$$

$$R_{D2} = (M_L/L/2.43) \text{TAN } (6.754^\circ) \quad (2)$$

The summation of forces in the 2 direction yields the transverse reaction supplied by the hinge.

$$R_{L2} = 2 R_{D2} \quad (3)$$

This force,  $F_{L2}$  in figure 3, represents a load applied by the lead/lag link to the lead/lag pin assembly.

The summation of forces in the axial direction (figure 4) yields

$$R_{L1} = 0 \quad (4)$$

The forces,  $F_{D1}$  and  $F_{D2}$  shown in figure 3, are now known and are equal and opposite to the reactions  $R_{D1}$  &  $R_{D2}$  respectively.

The force in the damper,  $F_D$ , is the resultant of  $F_{D1}$  and  $F_{D2}$ .

$$F_D = F_{D1}/\cos (6.754^\circ) \quad (5)$$

Substituting equation (1) for  $F_{D1}$  yeilds

$$F_D = M_L/L/ ((2.43) \cos (6.754^\circ)) \quad (6)$$

$$F_D \doteq .414 M_L/L \quad (7)$$

These same components act on the pitch case at the inboard end of the dampers. Figure 5 shows a free body with the applied damper loads. The pitch case free body is pin supported at the lead/lag hinge and roller supported at the flap/feather bearing. The inplane reaction supplied by the lead/lag pin,

$R_{p2}$ , due to the damper loads is found by the summation of moments about the flap/feather bearing and is given as

$$M_{F/F} = 6.345 R_{p2} - 3.645 F_{D1} - 2(1.215) F_{D2} = 0 \quad (8)$$

Substituting equation (1) and (2) into (8) and solving for  $R_{p2}$  yields

$$R_{p2} \doteq .255 M_{L/L} \quad (9)$$

The force,  $F_{p2}$  in figure 3, that is applied by the pitch case to the strap pack via the lead/lag pin assembly is equal and opposite to  $R_{p2}$ .

The inplane reaction,  $R_{F2}$ , supplied by the flap/feather bearing, is found by the summation of transverse forces shown in figure 5

$$R_{F2} = R_{p2} - 2 F_{D2} \quad (10)$$

and substituting for  $R_{p2}$  and  $F_{D2}$  yields

$$R_{F2} = M_{L/L}/6.345 \quad (11)$$

The load applied to the strap pack at the lead/lag hinge due to the lead lag link and the pitch case is shown in figure 6 and identified as  $F_{S2}$ .

$$F_{S2} = F_{p2} - 2 = M_{L/L}/6.345 \quad (12)$$

The loads in the strap pack legs,  $R_A$  and  $R_B$ , due to  $F_{S2}$  are determined by geometry as described in the following centrifugal force section.

## Centrifugal Force

The centrifugal load is transferred from the blade root end to the strap pack via the lead/lag pin. A free body of this load transfer into the strap pack is shown in figure 7.

The load is shown applied to the strap pack in figure 6. The transverse force,  $F_{S2}$  described above, is also shown. The reactions,  $RA$  and  $RB$ , and their components can be found as follows:

The summation of moments about point 'B' yields

$$\begin{aligned}\Sigma M_B &= 0 \\ CF(2.53/2) &= 2.53 RA_1 + 7.425 F_{S2}\end{aligned}\tag{13}$$

Substituting for  $F_{S2}$  in terms of  $M_{L/L}$  yields

$$RA_1 = CF/2 - .4625 M_{L/L}\tag{14}$$

Summation of radial forces yields

$$RB_1 = CF - RA_1\tag{15}$$

Assuming truss like behavior

$$RA = RA_1/\cos 9.67^\circ\tag{16}$$

$$RB = RB_1/\cos 9.67^\circ\tag{17}$$

Simplifying

$$RA = .507 CF - .469 M_{L/L}\tag{18}$$

$$RB = .507 CF + .469 M_{L/L}\tag{19}$$

## Flapwise Moment

The flapwise moment, figure 8, is given as  $M_F$  at the blade root end and goes to zero at the flap/feather bearing. The strap pack provides essentially no bending stiffness (2.7 in-lb/deg  $\beta$ ) thus it is only slightly conservative to consider this capability for stress analysis of the strap pack alone. The flap-

wise moment is tracked into the hub using the above assumptions. The moment is transferred through the lead/lag link as a couple,  $F_{L1}$ , into the lead/lag pin.

$$F_{L1} = M_F / (1.08) \quad (20)$$

The pin transfers the moment as a couple,  $F_{P1}$ , into the pitch case.

$$F_{P1} = M_F / (1.72) \quad (21)$$

Taking the pitch case as a free body, the flap/feather bearing reaction and the vertical reaction at the lead/lag link can be determined.

$$F_{P3} = F_{F3} = M_F / (6.345) \quad (22)$$

#### Torsion

The pitching moment carried by the control system,  $M_T$ , is a specified load. It is the torque needed to overcome blade root torsion and to twist the centrifugally stiffened strap pack to a required pitch. This torque is uniform throughout the length of the pitch case. The control load is shown in figure 9. The  $F_{T2}$  force couple is shown applied to the lugs at the outboard end of the pitch case.

$$F_{T2} = M_T / (1.72) \quad (23)$$

The  $R_{T2}$  force couple is the reaction supplied by the pitch link and flap/feather bearing.

$$R_{T2} = M_T / (2.56) \quad (24)$$

## Component Load Summary

For stress analysis purposes, it is convenient to have the various component forces in terms of blade root loads. By substitution, these forces are:

### Lead/lag hinge forces

$$F_{P1} = M_F / (1.72) \quad (21) \quad F_{P2} = .255 M_L / 6.345 \quad (9) \quad F_{P3} = M_F / 6.345 \quad (22)$$

$$F_{L1} = M_F / 1.08 \quad (20) \quad F_{L2} = .0958 M_L / L \quad (3)$$

$$CF \quad F_{T2} = M_T / 1.72 \quad (23)$$

### Damper Forces

$$F_{D1} = M_L / L / 2.43 \quad (1)$$

$$F_{D2} = .0479 M_L / L \quad (2)$$

### Flap/Feather Bearing Forces

$$F_{F2} = M_L / L / 6.345 \quad (11)$$

$$F_{F3} = M_F / 6.345 \quad (22)$$

### Strap Pack Forces

$$F_{S1} = CF \quad (25) \quad F_{S2} = F_{P2} + F_{L2} = .2534 M_L / L \quad (12)$$

$$RA = .507 CF - .469 M_L / L \quad (18)$$

$$RB = .507 CF + .469 M_L / L \quad (19)$$

## STRESS ANALYSIS

Areas for stress analysis presented in the paper are those that are considered critical and/or that can contribute to the analysis presented in the Hughes stress document.

### Lead/Lag Hinge

As shown in the appendix, the lead lag joint is bending critical. The bolt bending force  $P$  used to calculate the pin assembly bending moment (see appendix A) is the vector addition of the strap pack transverses and radial forces.

$$P = F_{S1} \ddagger F_{S2} \quad (26)$$

$$P = CF \ddagger .2534 M_L/L \quad (27)$$

For the limit load case

$$P = 6186 \ddagger .2534 (2380) = 6215 \text{ lbs.} \quad (28)$$

The applied bending moment is then calculated per appendix A equation (7) and is

$$(.443) \frac{6215}{2} = 1378 \text{ in-lbs} \quad (29)$$

This applied limit load moment is plotted in figure 14. Bolt preload was selected based on the constraints of gapping and tension yield in the bolt threaded area due to preload.

For the applied load of 1378 in-lbs a required preload force is calculated as described in the appendix

$$P_{REQ} = \frac{1378 + 111.4}{.1211} = 12,299 \text{ lbs} \quad (30)$$

Based on a least squares fit of bolt preload vs bolt stretch data (fig 18), the required bolt stretch in thousandths,  $\Delta L_{REQ}$ , is

$$\Delta L_{REQ} = \frac{P + 470}{1.11996} = 11.4 \text{ thousandths} \quad (31)$$

specifying a minimum bolt stretch of .0120 yields a limit load margin of safety of

$$M.S. = \frac{.0120}{.0114} - 1 = +.05 \quad (\text{Limit}) \quad (32)$$

The specified maximum bolt preload based on a stretch of .0125 is

$$P = 1119.96 (12.5) - 470 = 13,509 \text{ lbs} \quad (33)$$

Bolt limit allowable preload is 14,264 pounds. Based on this preload the margin of safety at maximum installation preload is

$$\frac{14264}{13509} - 1 = +.05 \quad (\text{Limit}) \quad (34)$$

Thus for limit load conditions the joint is equally critical for gap initiation and bolt yield due to preload.

Joint ultimate bending strength is satisfied thru the plastic bending strength of the bolt. The shape factor for the bolt is 1.7 giving the modulus of rupture,  $F_b$ , as (ref 4)

$$F_b = 1.7 (FTU) = 1.7 (260,000) = 442,000 \text{ PSI} \quad (35)$$

The applied ultimate bending moment is 1.5 times the limit bending moment and is

$$M_{ult} = 1.5 (1378) = 2067 \text{ in-lb} \quad (36)$$

The ultimate moment capability of the bolt,  $M_B$ , is given as

$$M_b = F_b Z \quad (37)$$

where  $Z$  is the section modulus for the 3/8 diameter bolt

$$Z = I/C = .005115 \text{ in}^3 \quad (38)$$

then

$$M_B = (442,000) (.005115) = 2260 \text{ in-lb} \quad (39)$$

The margin of safety is

$$\text{M.S.} = \frac{M_B - M_{ult}}{M_B} = \frac{2260 - 2067}{2260} = + .08 \text{ (ult)} \quad (40)$$

The mean bolt shank stress for high cycle fatigue analysis is the stress due to preload plus the centrifugal bending stress. The alternating stress is due to the moment about the lead/lag hinge producing an inplane load. Per the elastic analysis described in appendix A the stresses are

$$\begin{aligned} f_{\text{mean}} &= f_{BI} + \frac{M_{CF} D/2}{I_{\text{total}}} = 118,721 + \frac{1378 (3/16)}{.01014} \\ &= 144,201 \text{ psi} \end{aligned} \quad (41)$$

where

$M_{cf}$  is the pin bending moment due to CF

$D$  is the bolt diameter

$I_{\text{total}}$  is the combined moment of inertia for the bolt and sleeve



The alternating stress due to the alternating moment about the lead/lag hinge is

$$f_{alt} = (F_{P2} - 2F_{D2}) \frac{D/2}{I_{total}} = \pm 1400 \text{ psi} \quad (42)$$

Per figure 2.3.1.1.8 (h) of reference 5 (Goodman diagram for 300M steel, FTU = 280 KSI) the bolt has an infinite fatigue life and a large margin of safety.

Low cycle fatigue analysis is performed in the same manner with the mean stress taken to be bolt preload

$$f_{mean} = f_{BI} = 118,721 \text{ psi} \quad (43)$$

The alternating stress is taken to be the maximum limit load shank stress. This is due to the applied limit bending moment of 1378 in-lbs

$$f_{alt} = \frac{My}{I} \quad (44)$$

where  $y = 1/2$  the bolt diameter = .1872 in.

$I =$  combined moment of inertia of sleeve and bolt = .01014 in<sup>4</sup>

then

$$f_{alt} = \frac{1378 (.1872)}{.01014} = 25,440 \text{ psi} \quad (45)$$

Using the same Goodman diagram as for high cycle fatigue the bolt has an infinite fatigue life and a large margin of safety.

### Pitch Case Clevis at Lead/Lag Hinge

A lug from the pitch case clevis is shown in figure 16. Section A-A was selected for stress check. The stress at points 'A' and 'B' can be calculated based axial on force and bending about the 2 and 3 axes

$$f_A = k_{tA} \left[ \frac{.69 F_2}{Z_3} + \frac{.91 F_{P3}}{Z_2} + \frac{F_1}{A} \right] = k_{tA} [7.36 F_2 + 78.4 F_{P3} + 3.15 F_1] \quad (46)$$

$$f_B = k_{tB} \left[ \frac{(.08) (.69) F_2}{I_3} + \frac{.91 F_{P3}}{Z_2} + \frac{F_1}{A} \right] = k_{tB} [.736 F_2 + 78.4 F_{P3} + 3.15 F_1] \quad (47)$$

The forces  $F_1$  and  $F_2$  can be determined from figure 11.

$$F_1 = F_{P1} \quad (48)$$

$$F_2 = F_{T2} + .5 F_{P2} \quad (49)$$

Substituting blade root loads for  $F_{P1}$ ,  $F_{T2}$ ,  $F_{P2}$  and  $F_{P3}$

$$f_A = k_{tA} [4.28 M_T + .580 M_{L/L} + 14.2 M_F] \quad (50)$$

$$f_B = k_{tB} [.428 M_T + .0580 M_{L/L} + 14.2 M_F] \quad (51)$$

For the limit load case (See Table I) ( $k_t$  from ref 2)

$$k_{tA} = 1.4; f_A = 1.4 (21,306) = 29,827 \text{ psi} \quad (52)$$

$$k_{tB} = 2.6; f_B = 2.6 (15,741) = 40,927 \text{ psi} \quad (53)$$

$$M.S. = \frac{56,000}{40,927} - 1 = +.36 \text{ (Limit)} \quad (54)$$

For the high cycle fatigue load case (see Table I)

$$k_{tA} = 1.4; f_A = 796 + 12,093 \text{ psi} \quad (55)$$

$$k_{tB} = 2.6; f_B = 148 + 18,926 \text{ psi} \quad (56)$$

Per MIL-HDBK-5c fig 3.7.3.1.8(a) and conservatively using the unnotched curve for a constant life of  $10^7$  cycles, the fatigue margin of safety is

$$\text{M.S.} = \frac{21,000}{18,926} - 1 = +.11 \quad (\text{Fatigue}) \quad (57)$$

For the ultimate load case  $k_t$  is dropped from the equation. Based on elastic analysis and using a factor of safety of 1.5.

$$f_A = 1.5 \times 21,306 = 31,959 \quad (58)$$

$$f_B = 1.5 \times 15,741 = 23,612 \text{ psi} \quad (59)$$

$$\text{M.S.} = \frac{67,000}{31,959} - 1 = +1.10 \quad (\text{Ultimate}) \quad (60)$$

For the low cycle fatigue case, taking the minimum stress to be zero and the maximum stress to be the limit load stress, the fatigue life of the part is approximately  $2 \times 10^6$  start/stop cycles.

### Strap Pack

The strap legs are stressed due to the inplane loads shown in figure 6 and due to the out-of-plane flap/cone motion shown in figure 15.

The stresses due to the inplane loads shown in figure 6 are

$$f_{RA} = \frac{RA}{A_S} = \frac{RA}{.0478} \quad (61)$$

$$f_{RB} = \frac{RB}{A_S} = \frac{RB}{.0478} \quad (62)$$

The strap legs, due to their flexibility, have essentially no compressive strength. Therefore, the trailing strap, attached at point A, must remain in tension. This is critical for the limit load case where

$$CF = 6186 \text{ lbs and } M_{L/L} = 2380 \text{ in-lb (Table I)} \quad (63)$$

Then

$$RA = 2020 \text{ lbs tension} \quad (64)$$

The stress in the leading strap,  $f_{RB}$ , is combined with stresses due to out of plane motion.

The strap pack is made up of eleven routed stainless steel sheet laminates, .009 thick each. They are stacked together and joined by interference fit bushings at the three holes shown. No interlaminar adhesive is used. The strap pack assembly is prestressed into the plastic range to insure equal load sharing of the straps for  $\beta = 0$ .

Under centrifugal load the strap is assumed to deform out of plane to the shape shown in the figure 15. That is, the strap pack remains straight except

where it conforms to the radius shoe as it is clamped between the upper and lower hub plates.

The centerline length of the strap pack remains unchanged (7.425 inches) as the blade flaps. The individual straps, however, do take on a new length and the tension in the strap increases or decreases accordingly. The change in length in the  $i^{\text{th}}$  strap can be the difference between the distance  $L'$  at the centerline of the strap pack and  $L'$  of the  $i^{\text{th}}$  strap.

$$\Delta L_i = L'_i - L'_{\text{centerline}} \quad (65)$$

The distance  $L'$  for a given strap is a function of its radial distance,  $R$ , and the flap/cone angle,  $\beta$ .

$$L'_i = R_i \beta \pi / 180^\circ \quad (66)$$

where

$$R_i = 3 + (i-1)(t) + t/2 \quad (67)$$

$\beta$  is in degrees

The centerline distance,  $L'_{\text{centerline}}$ , is calculated for  $R = 3.0495$

$$L'_{\text{centerline}} = .05322\beta^\circ \text{ (inches)} \quad (68)$$

The stress in a strap due to this change in length,  $f_{\Delta L}$ , is uniform throughout its length (no interlaminar adhesive). This stress is expressed as

$$f_{\Delta L} = \frac{\Delta L_i E}{L} = \frac{\pi}{180} \beta^\circ (R_i - R_{\text{centerline}}) \frac{E}{L} \quad (69)$$

where  $L$  is the total strap length (7.425) and  $E$  is the modulus of elasticity for the strap (29.E6).

In addition to this uniform stress throughout the leg of the individual strap,  $f_{\Delta L}$ ; there is a bending stress,  $f_{B_i}$  in the area where the strap conforms to the shoe radius.

$$f_{B_i} = \frac{tE}{2 R_i} = \frac{.131 \times 10^6}{R_i} \quad (\text{ref. 5}) \quad (70)$$

The maximum tensile stress in a strap due to flapping and inplane loading occurs in the lower strap ( $i = 11$ ) and is

$$\begin{aligned} f_{i=11} &= f_{\Delta L_{11}} + f_{B_{11}} + f_{RB} \\ &= 3374\beta^\circ + 42171 + 10.60 \text{ CF} + 9.81 M_{L/L} \end{aligned} \quad (71)$$

For the limit load case  $\beta = 12^\circ$ ,  $\text{CF} = 6186 \text{ lb}$ , and  $M_{L/L} = 2380 \text{ in-lb}$

$$f_{i=11} = 171,583 \text{ psi}$$

The limit load margin of safety is

$$\text{M.S.} = \frac{220,000}{171,583} - 1 = +.28 \quad (\text{Limit}) \quad (72)$$

Using elastic analysis for the ultimate load case and,  $\beta = 12^\circ$ ,  $\text{CF} = 9279 \text{ lbs}$ , and  $M_{L/L} = 3570 \text{ in-lbs}$ . Then

$$f_{i=11} = 216,038 \text{ psi}$$

which is still in the elastic range of the material. The ultimate margin of safety is conservatively

$$\text{M. S.} = \frac{242,000}{216,038} - 1 = +.12 \quad (\text{Ultimate}) \quad (73)$$

The fatigue stresses corresponding to  $\beta = 3.8^\circ \pm 4.0^\circ$ ,  $\text{CF} = 5636 \text{ lb}$ , and  $M_{L/L} = 368 \pm 765 \text{ in-lb}$  are

$$\begin{aligned} f_{\text{mean}} &= 3374 (3.8) + \frac{42171}{2} + 10.60(5636) + 9.81(368) \\ &= 97,258 \text{ psi} \end{aligned} \quad (74)$$

$$\begin{aligned}
 f_{alt} &= \pm \left[ 3374(4.0) + \frac{42171}{Z} + 9.81(765) \right] \\
 &= \pm 42,086 \text{ psi}
 \end{aligned}
 \tag{75}$$

The stress ratio, R, is

$$R = \frac{97,258 - 42,086}{97,258 + 42,086} = .40
 \tag{76}$$

Unpublished Hughes data indicates a mean endurance limit for the strap material of  $\pm 82,000$  psi with a stress ratio of  $R = .05$  (A mean stress of 90,600 psi). Based on the Goodman equation, an alternating stress allowable for the increased mean stress can be calculated

$$\begin{aligned}
 F_{alt} &= \left( \frac{F_{TU} - F_{mean}}{F_{TU} - F_{mean_{test}}} \right) f_{alt_{test}} \\
 &= \frac{(242,000 - 97,258)}{242,000 - 90,600} 82,000 \\
 &= \pm 78,393 \text{ psi}
 \end{aligned}
 \tag{77}$$

using this allowable, the fatigue margin of safety is

$$M. S. = \frac{78,393}{42,086} - 1 = + .86 \text{ (Fatigue)}
 \tag{78}$$

For low cycle fatigue, the mean stress is taken to be zero and the maximum stress is taken to be the limit load stress.

Then

$$F_{alt} = f_{mean} = 1/2 f_{max} = 85,800 \text{ psi}
 \tag{79}$$

## HUB SHOE

The leading strap pack leg, under the tension load  $RB$ , bears against the hub shoe with the out of plane deflection  $\beta$  (Figure 17). This bearing load, with resultant  $R$ , causes cantilever bending of the shoe.†

The tension load,  $RB$ , is transferred into the hub plate through a fastener in double shear. The shoe is stressed for the tension load and cantilever bending at the cross section through the bolt hole.

From statics the resultant of the bearing forces is

$$R = \frac{RB - RB \cos (\beta + 6.62^\circ)}{\sin \frac{(\beta + 6.62^\circ)}{2}} \quad (80)$$

and the moment arm,  $D$ , to the CG of the bending section is

$$D = \frac{.87}{\cos \beta} + 2.865 \sin [(\beta - 6.62)/2] \quad (81)$$

---

† The force  $R$  is the primary source for thrust and control moment transfer into the hub.



The section properties of the effective cross section are

$$A = .3435 \text{ in}$$

$$Z = .0286 \text{ in}^3$$

$$K_{tb} = 2.1 \text{ for bending ref. 1 (Roark)}$$

$$K_{tp} = 3.6 \text{ for pin loaded hole ref. 2 (Bruan)}$$

For the limit load case

$$RB = 4,252 \text{ lbs} \ \& \ \beta = 12^\circ$$

$$R = 1,376 \text{ lbs}$$

$$D = 1.024 \text{ inches}$$

$$f = k_{tb} \frac{R(D)}{Z} + K_{tp} \frac{RB}{ZA} \quad (82)$$

$$= 103,519 + 22,281$$

$$= 125,800 \text{ PSI Limit}$$

$$\text{M.S.} = \frac{132,000}{125,800} - 1 = \underline{+} .05 \text{ (Limit)} \quad (83)$$

For the ultimate load case the stress concentration factors are dropped and with plastic analysis the margins-of-safety are large.

For the fatigue load case maximum and minimum stresses are calculated. The alternating loads are due to the lead/lag moment and flapping.

Where

$$CF = 5,636 \text{ lbs}$$

$$M_{L/L} = 368 \underline{+} 765 \text{ in-lbs}$$

$$\beta = 3.8^\circ \underline{+} 4.0^\circ$$

For the maximum stress condition

$$RB = 3,389 \text{ lbs}$$

$$R = 851 \text{ lbs}$$

$$D = .908 \text{ inches}$$

and the maximum net stress (stress concentration not applied)

$$\begin{aligned} f_{\max} &= \frac{R(D)}{Z} + \frac{RB}{2A} & (84) \\ &= 26,654 \text{ PSI} \end{aligned}$$

For the minimum stress condition

$$\begin{aligned} RB &= 2,671 \text{ lbs} \\ R &= 298 \text{ lbs} \\ D &= .70 \text{ in} \end{aligned}$$

and the minimum net stress is

$$\begin{aligned} f_{\min} &= \frac{R(D)}{Z} + \frac{RB}{2A} & (85) \\ &= 10,968 \text{ PSI} \end{aligned}$$

This corresponds to a mean stress of 18,811 PSI and an alternating stress of 7,843 PSI PER MIL-HDBK-5c figure 2.3.1.1.8 (b) and using curves for  $K_t = 3.3$  the allowable alternating stress is  $\pm 29,000$  PSI for the applied mean stress. The fatigue margin of safety is:

$$\text{M.S.} = \frac{29,000}{7,843} - 1 = 2.7 \text{ (Fatigue)} \quad (86)$$

Again, for low cycle fatigue, the maximum stress is taken to be limit load stress and the minimum stress is zero. Then

$$f_{\text{mean}} = f_{\text{alt}} = \frac{1}{2} f_{\text{limit}} = 62,900 \text{ psi} \quad (87)$$

Using the above fatigue the part is good for approximately 200,000 start/stop cycles.

## CONCLUSIONS

The model AH-64 hub/retension is equally critical for limit loads at the lead/lag hinge and the hub plate. Margins of safety for areas stress checked in this document are presented in Table II. It is critical in ultimate strength at the lead/lag hinge and in fatigue in the strap pack. For the given design loads all margins of safety are positive and the fatigue life is greater than 148 hours at 105% RPM ( $>10^7$  cycles), or 200,000 start/stop cycles. Joint preload is controlled by measured bolt stretch at the time of installation. This length is recorded and then checked periodically for relaxation during the test life of the hub.

Using the analysis in this report, and the analysis provided by Hughes the hub/retension system strength can be evaluated for operating and/or hardware modifications.

## Appendix A

### LEAD/LAG HINGE

#### Limit Load Analysis

The lead/lag hinge pin assembly is bending critical and depends upon bolt preload for its flexural strength. A general description of its bending capability is described below.

A cross section through the lead/lag hinge is shown in figure 10. Based on the load path section above, forces applied to the pin assembly can be determined. Figure 11 shows the applied forces described above collected at the lead/lag hinge pin.

The bending strength of the bolt alone is inadequate to carry the applied limit load. The combined moment of inertia of the sleeve and bolt is used to resist the applied bending moment. The sleeves, discontinuous at the strap pack shoe, can be considered a continuous bending element when sufficient bolt preload is applied.

The bending moment in the pin assembly is maximum at the centerline of the strap pack. The moment here is due to centrifugal force (CF) and transverse forces resulting from the lead/lag moment ( $F_{P2}$ ,  $F_{D2}$ ). Forces resulting from flapwise bending ( $F_{L1}$ ,  $F_{P1}$ ) and torsion ( $F_T$ ) produce no moment in the pin at the centerline of the strap pack and are not considered in the bending strength analysis.

Initial bolt preload force,  $P$ , induces a tension stress in the bolt ( $f_{BI}$ ) and a compression stress in the sleeves ( $f_{SI}$ ) as shown in figure 12. This

is the ideal (zero tolerance parts) stress state at the sleeve/strap pack interface.

$$f_{BI} = \frac{\text{Preload Force}}{\text{Bolt Shank Area}} = \frac{P}{.1095} \quad (1)$$

$$f_{SI} = \frac{\text{Preload Force}}{\text{Sleeve Area}} = \frac{P}{.2477} \quad (2)$$

The preload stress distribution, shown as uniform in figure 12, will be skewed when part tolerances are considered. Parallelism of clamped surfaces is the primary tolerance influencing the initial stress uniformity. Based on a total build up of .010 out of parallel, it was determined that the sleeve compressive stress ( $f_{SI}$ ) can vary by  $\pm 3,700$  psi. This stress tolerance,  $f_{tol}$ , is applied conservatively to the analysis.

When centrifugal force and lead/lag moment is applied, the preload stress state is altered by pin bending (figure 13). On the tension bending side of the hinge centerline, the preload compressive stress in the sleeve ( $f_{SI}$ ) is relieved. This sleeve/shoe interface cannot support tension. Therefore, when this compressive stress is completely relieved,  $f_{ST} < 0$ , a gap will initiate and the combined sleeve/bolt bending analysis is no longer valid. Taking this gap initiation point as a limit load constraint, an allowable bending moment can be calculated

$$m \quad f_{ST} = f_{SI} - \frac{M}{Z} + f_{tolerance} \quad (3)$$

where  $Z$  is the section modulus for the bolt/sleeve combination given as .0301 in<sup>3</sup>.

$$\text{for } f_{ST} = 0$$

$$\begin{aligned}
 M_{\text{allowable}} &= Z(0 + f_{SI} - f_{tol}) & (4) \\
 &= .1211 P - 111.4
 \end{aligned}$$

This line is plotted as the gapping constraint on Figure 14. It also provides a means to calculate required bolt preload given an applied bending moment

$$P_{\text{required}} = \frac{M_{\text{applied}} - 111.4}{.1211} \quad (5)$$

The critical limitation for joint preload is net tension yield in the threaded portion of the bolt. The bolt is a 260 KSI tension head fastener with a 3/8 inch shank diameter. In house bolt load deflection tests establish tension yield rating of the fastener to be 17,830 lbs. (fig. 18). A maximum of 14,264 lbs is established as the maximum bolt preload for this joint (80% of yield). For reference purposes, the standard bolt preload for this fastener is 4000 to 7000 lbs. This is based on a torque prescribed to produce a preload of 1/3 of the bolt ultimate tensile rating.

Hence, gap initiation and fastener yield due to preload define the limit allowable envelope shown in figure 14. Sleeve compression yield and bolt shank tension yield were plotted on figure 14 but were not critical.

It remains to determine the applied bending moment as a function of the applied forces. Single pin bending analysis is used to calculate the moment at the centerline of the joint (ref. 7). The joint is analyzed (fig. 19) with the load P as the resultant of the transverse and radial forces in the strap pack, and P/2 reacted by the lead lag link.

When uniform bearing is assumed across the lead lag link excessive bolt preload is required. Since gapping is the critical bending constant, the

alternate ultimate bending analysis techniques described in reference 6 are not applicable. Therefore, a finite element analysis was performed.

The bearing distribution of the sleeve on the lead/lag link was determined by the finite element analysis (fig. 19). This bearing distribution was used to calculate the bending moment at the strap pack centerline.

The bending moment at the centerline of the bolt is then calculated per reference 6 as

$$M = \frac{Pb}{2} \tag{6}$$

$$\text{where } b = .120 + g + \frac{t_2}{4} = .443 \text{ in}$$

Then

$$M = .443 \frac{P}{2} \tag{7}$$

P is then determined in the body of the paper for limited and fatigue load cases.

#### REFERENCES

1. Roark, Raymond J., and Young, Warren C., Formulas for Stress and Strain, Fifth Edition, McGraw-Hill Book Company, 1975.
2. Bruhn, E. F.; Analysis and Design of Flight Vehicle Structures, Tri-State Offset Company, 1965.
3. MIL-HDBK-5C, Metallic Materials and Elements for Aerospace Vehicle Structures, 15 September 1976, Government Printing Office, P. O. Box 1533, Washington, D.C. 20013.
4. Shanley, F. R., Strength of Materials, McGraw-Hill Book Company, 1957.
5. Melcon, M. A. and Hoblit, F. M., Developments in the Analysis of Lugs and Shear Pins, Product Engineering, Vol. 24, No. 6, June 1953, pages 160-170.



TABLE I - BLADE ROOT LOADS

COMPONENT	LIMIT	ULTIMATE	FATIGUE	L <sub>g</sub> AT V <sub>H</sub>
M <sub>L/L</sub> Lead Lag Moment (in-lb)	2380	3570	368 + 765	276 + 535
CF Centrifugal Force (lbs)	618 <sup>a</sup> (110%)	9279	5636 (105%)	5112 (100%)
M <sub>F</sub> Flapwise Moment (in-lbs)	1065	1598	+502	+295
β° Cone Flap Motion (Degrees)	12°	12°	3.8° + 4.0°	2.6° + 2.4°
M <sub>T</sub> Torsional Moment (in-lb)	1122	1683	83 + 249	56 + 113

a. Based on actual model blade weight (not scaled from flight test) and supplied by Hughes.

TABLE II - MARGINS OF SAFETY

COMPONENT	MARGIN/FAILURE MODE			
	LIMIT	ULTIMATE	HIGH CYCLE FATIGUE	STOP START FATIGUE LIFE
LEAD/LAG HINGE	.05 GAP INITIATION & BOLT PRELOAD	.08 PLASTIC BENDING OF BOLT	LARGE BOLT SHANK COMBINED STRESS	
STRAP PACK @ HUB SHOE	.28 COMBINED STRESS CF, $M_L/L$ , $\beta$	.12 COMBINED STRESS CF, $M_L/L$ , $\beta$	.86 COMBINED STRESS CF, $M_L/L$ , $\beta$	
PITCH CASE LUG	.36 BENDING + AXIAL	1.01 BENDING + AXIAL	.91 BENDING + AXIAL	
HUB SHOE	.05 SHOE BENDING + BOLT LOAD	LARGE	2.7 SHOE BENDING + BOLT LOAD	

TABLE III COMPONENT MATERIAL

COMPONENT	MATERIAL	FTU	FTY
HUB PLATES	STEEL	90	70
STRAP PACK STRAPS	AM 355 CRT STEEL	242	220
LEAD/LAG LINK	6AL-4V TITANIUM	130	120
PITCH CASE	7049-T73 ALUMINUM	66	55
LEAD/LAG PIN SLEEVES	CUSTOM 455 STAINLESS STEEL	220	205
LEAD/LAG BOLT	STEEL	260	--

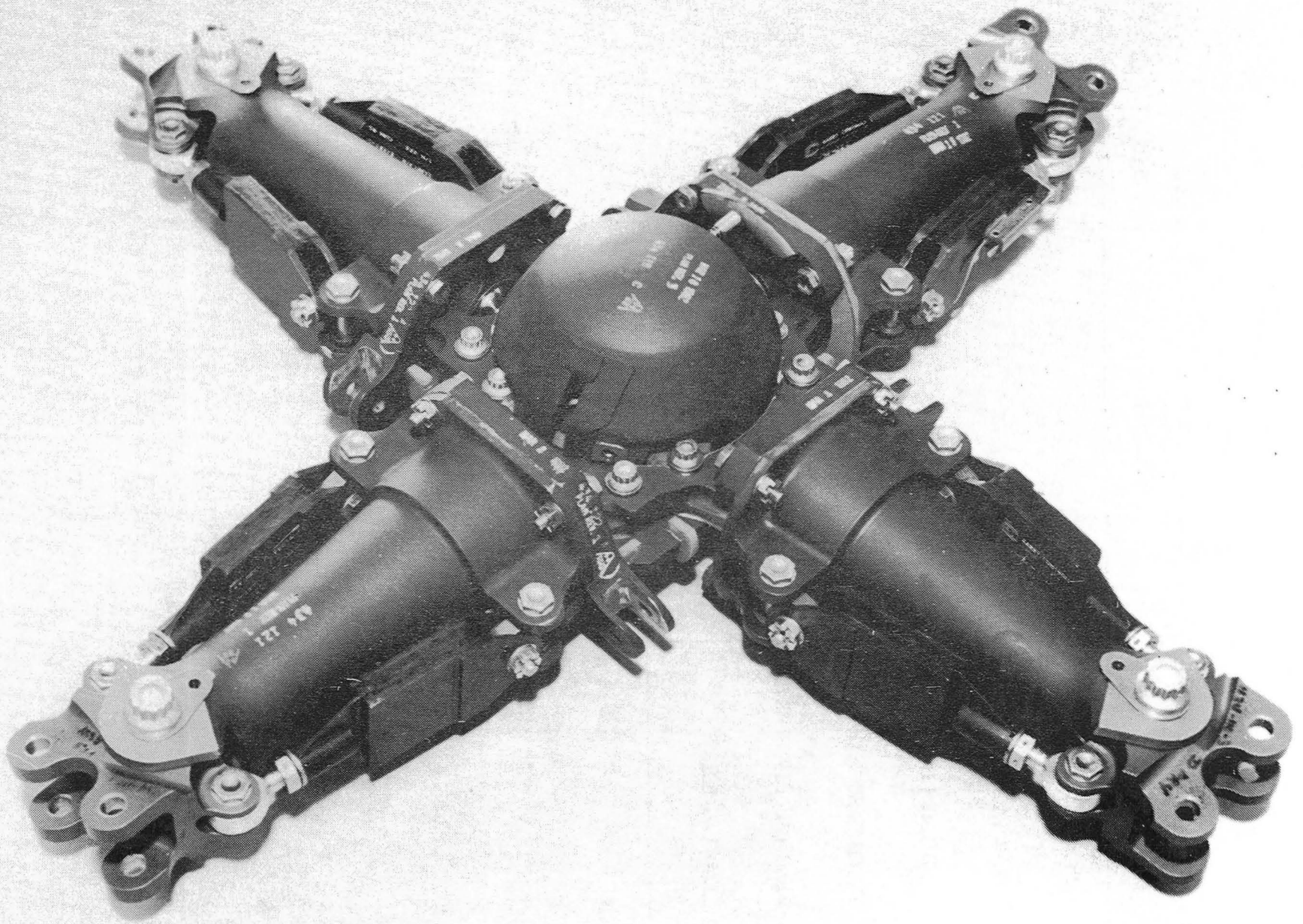

Figure 1. AH-64 27% scale model rotor hub.

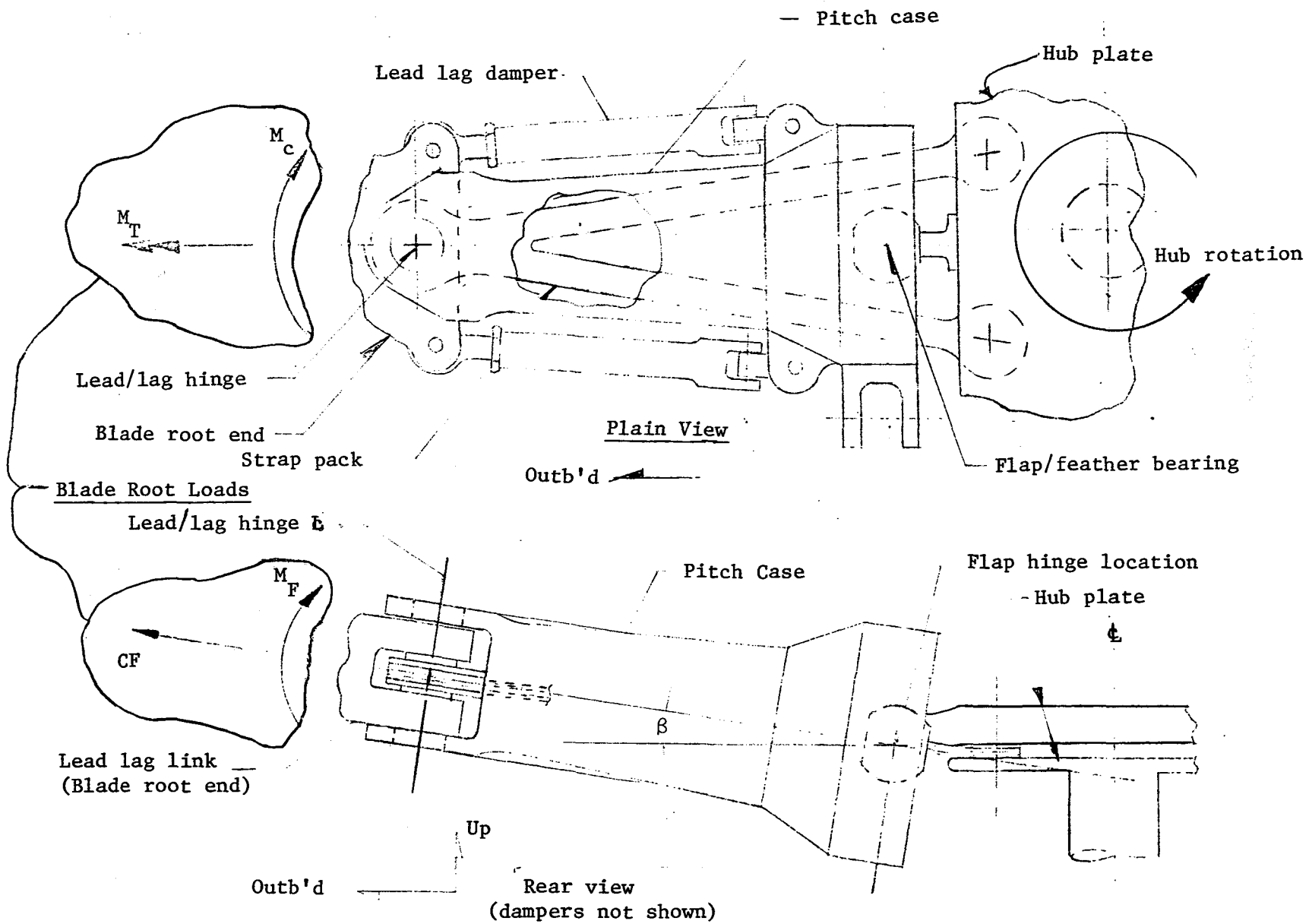

Figure 2. Hub/retention system

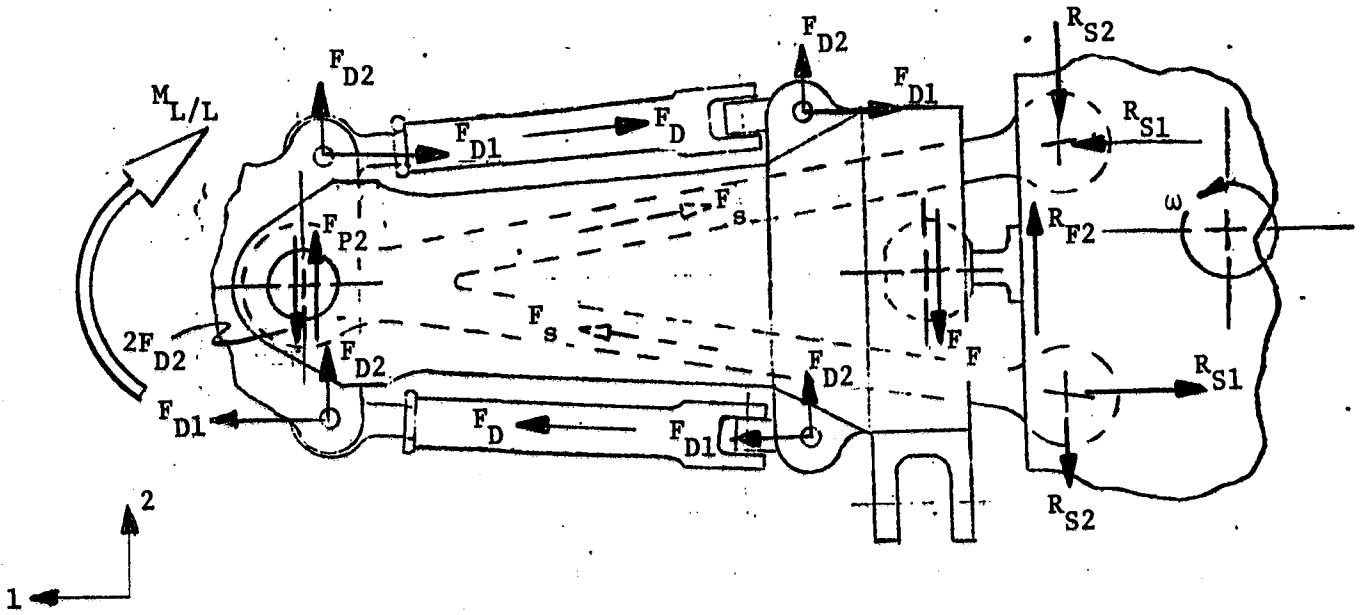

Figure 3.-Lead lag moment load path.

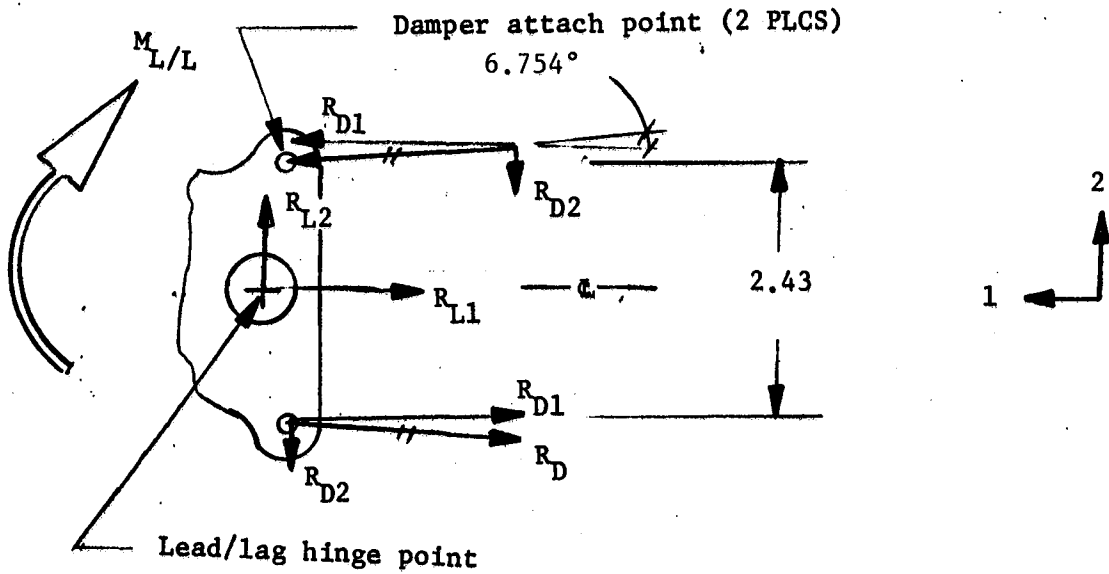

Figure 4.- Free body of lead/lag link.

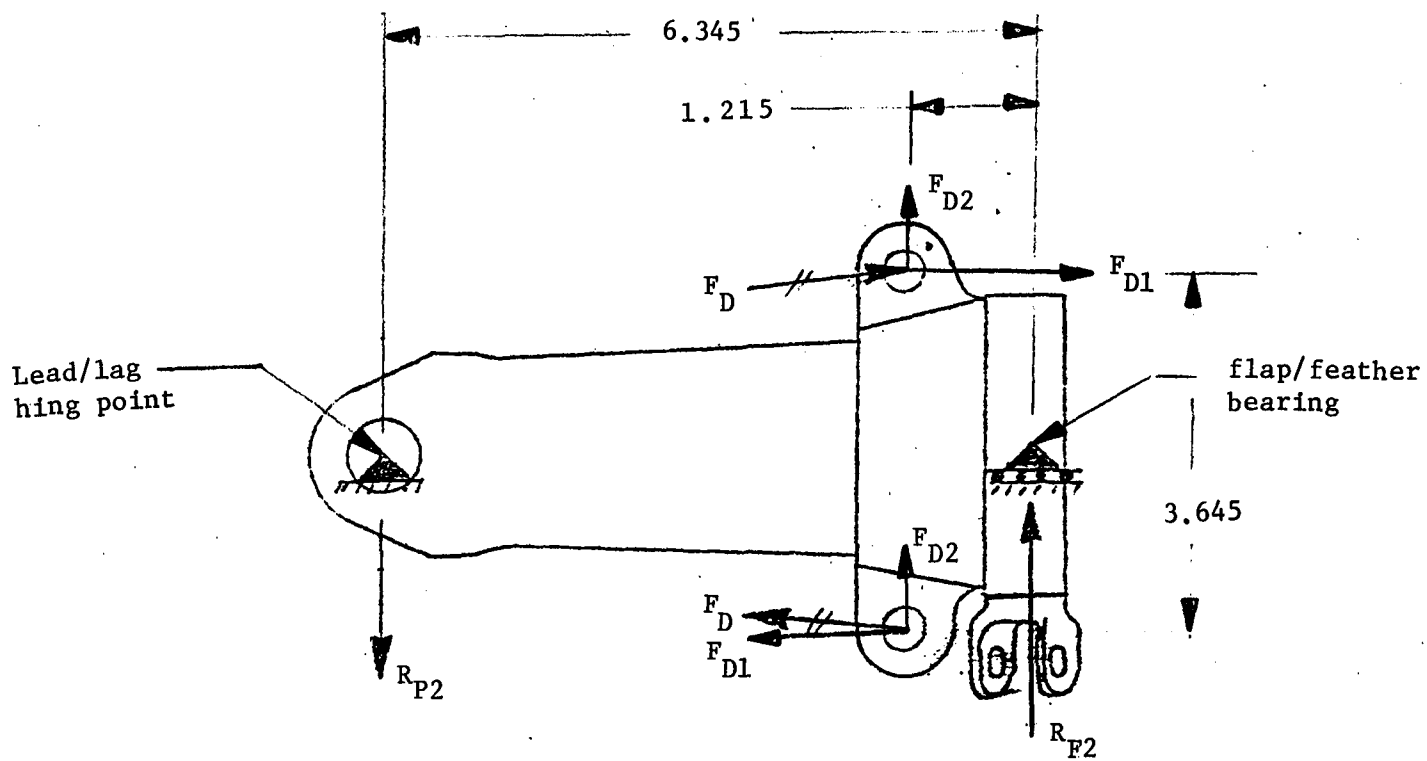

Figure 5.- Pitch case free body - plan view

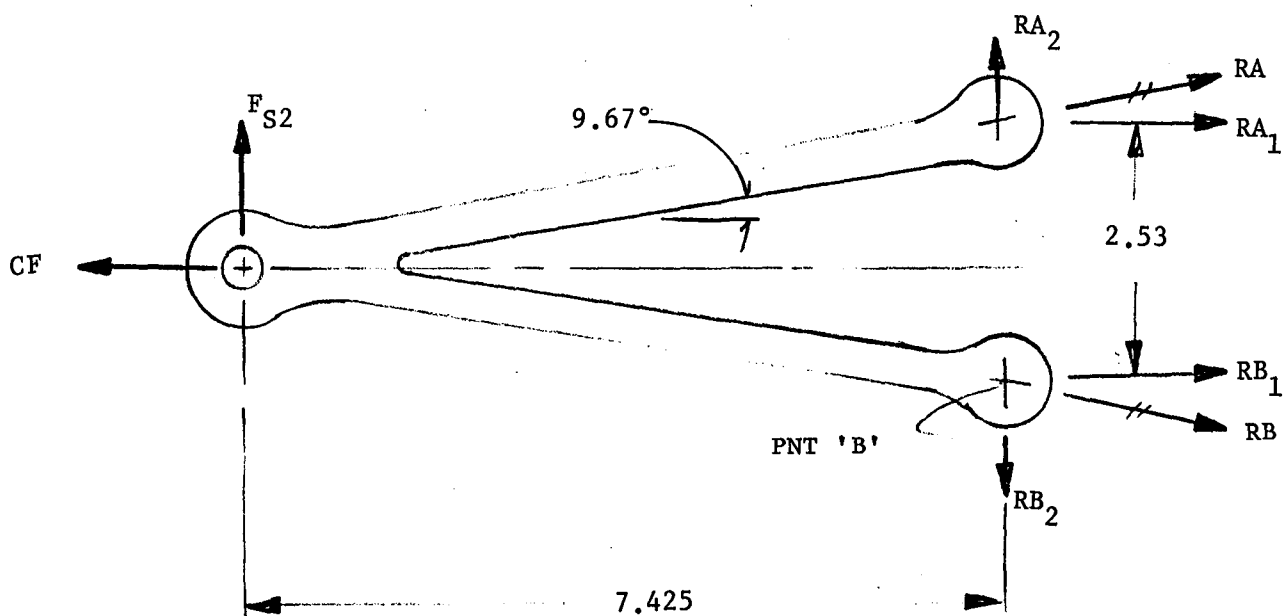

Figure 6.- Strap pack free body - plan view

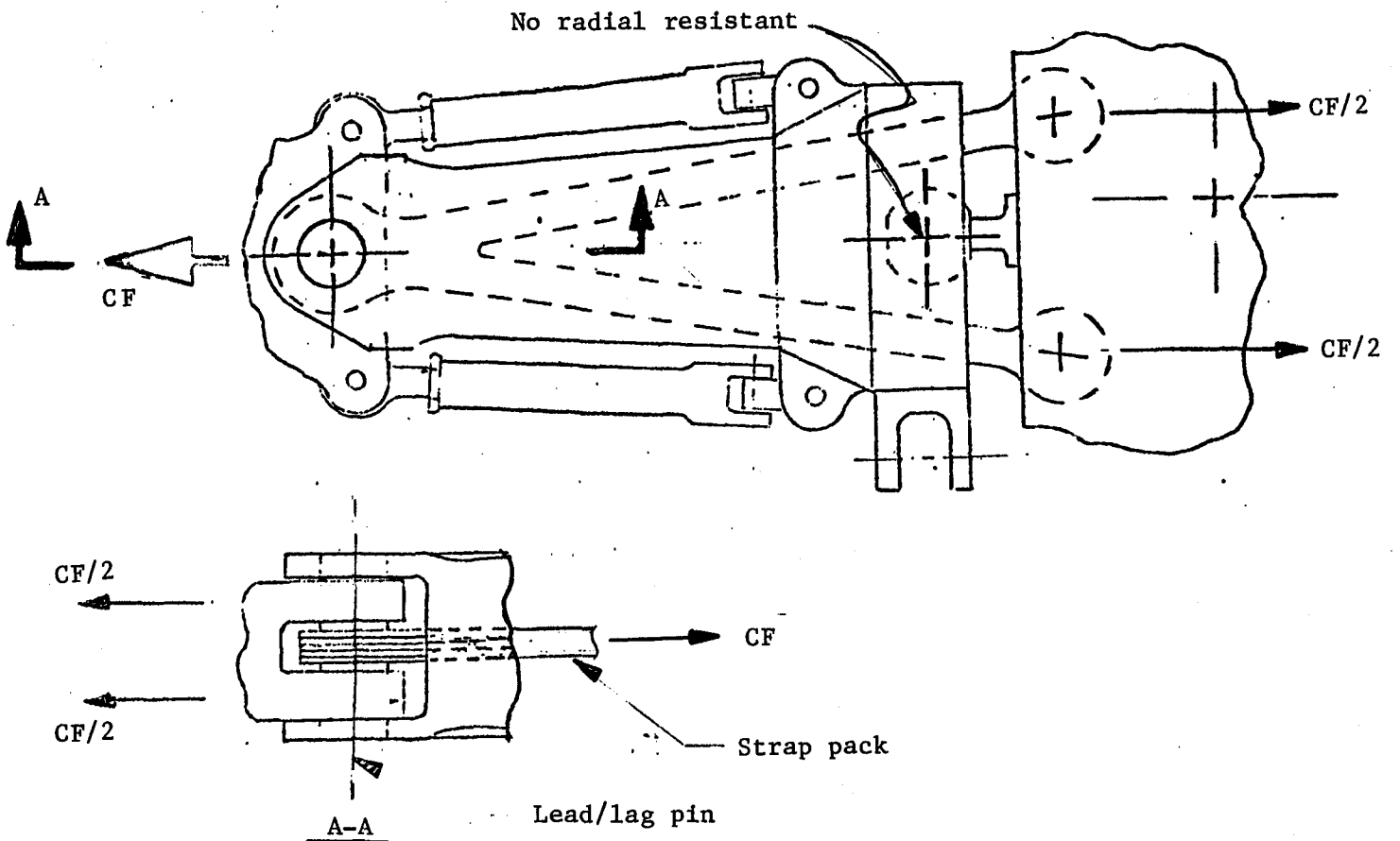

Figure 7.-Centrifugal force load path

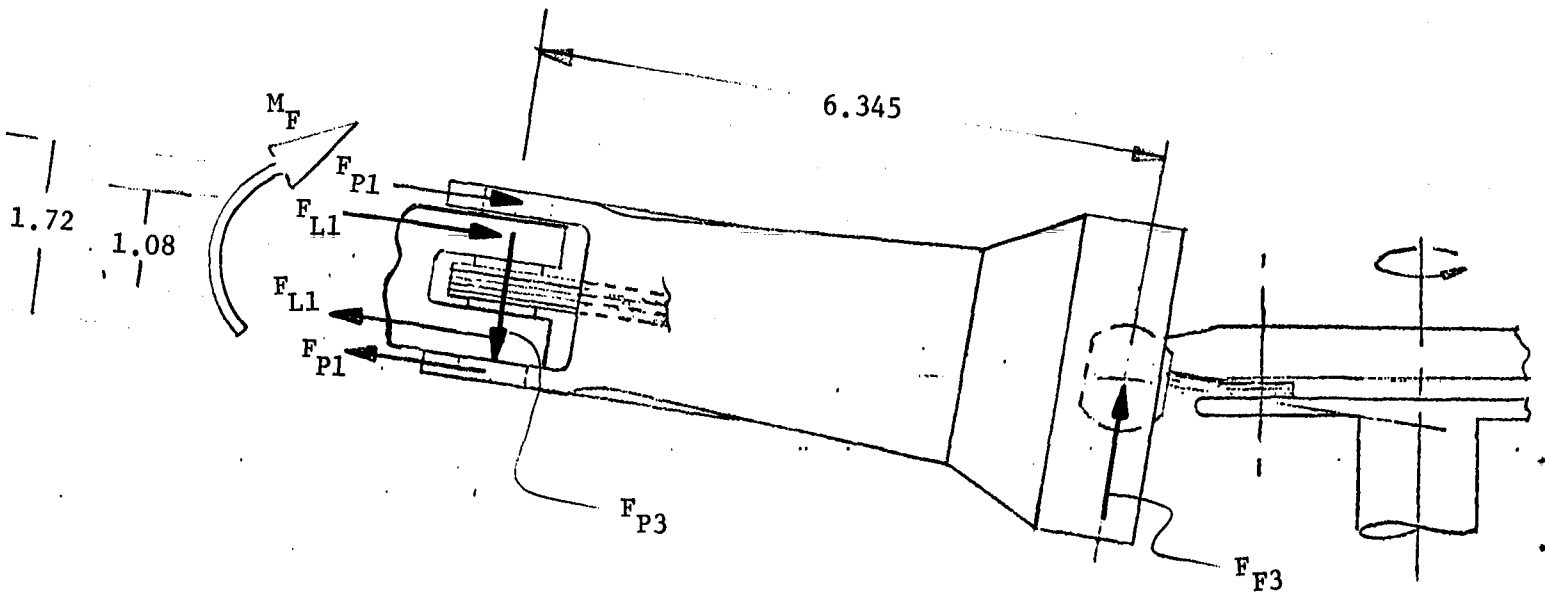
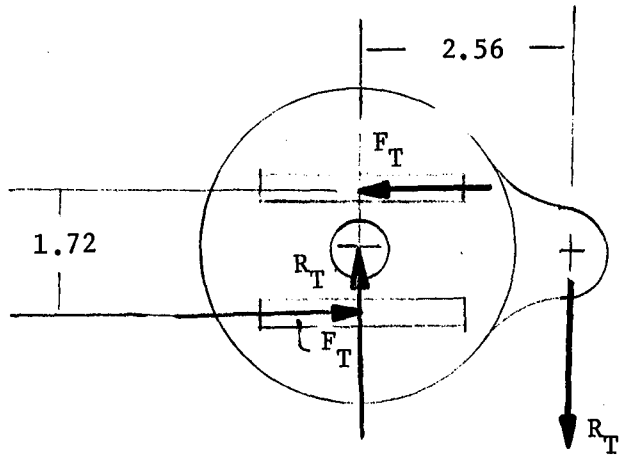
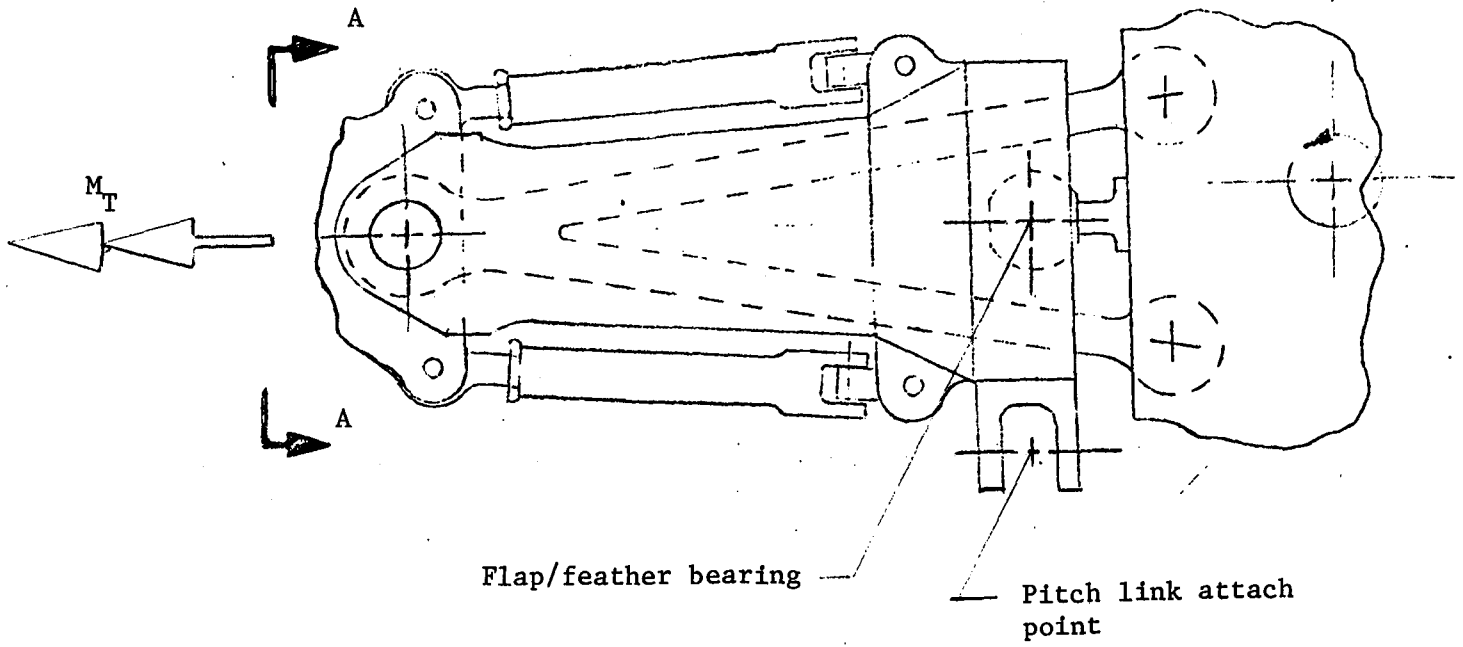

Figure 8.- Flapping moment load path





A-A  
(Pitch case shown only)  
rotated 90°

Figure 9.- Torsion load path

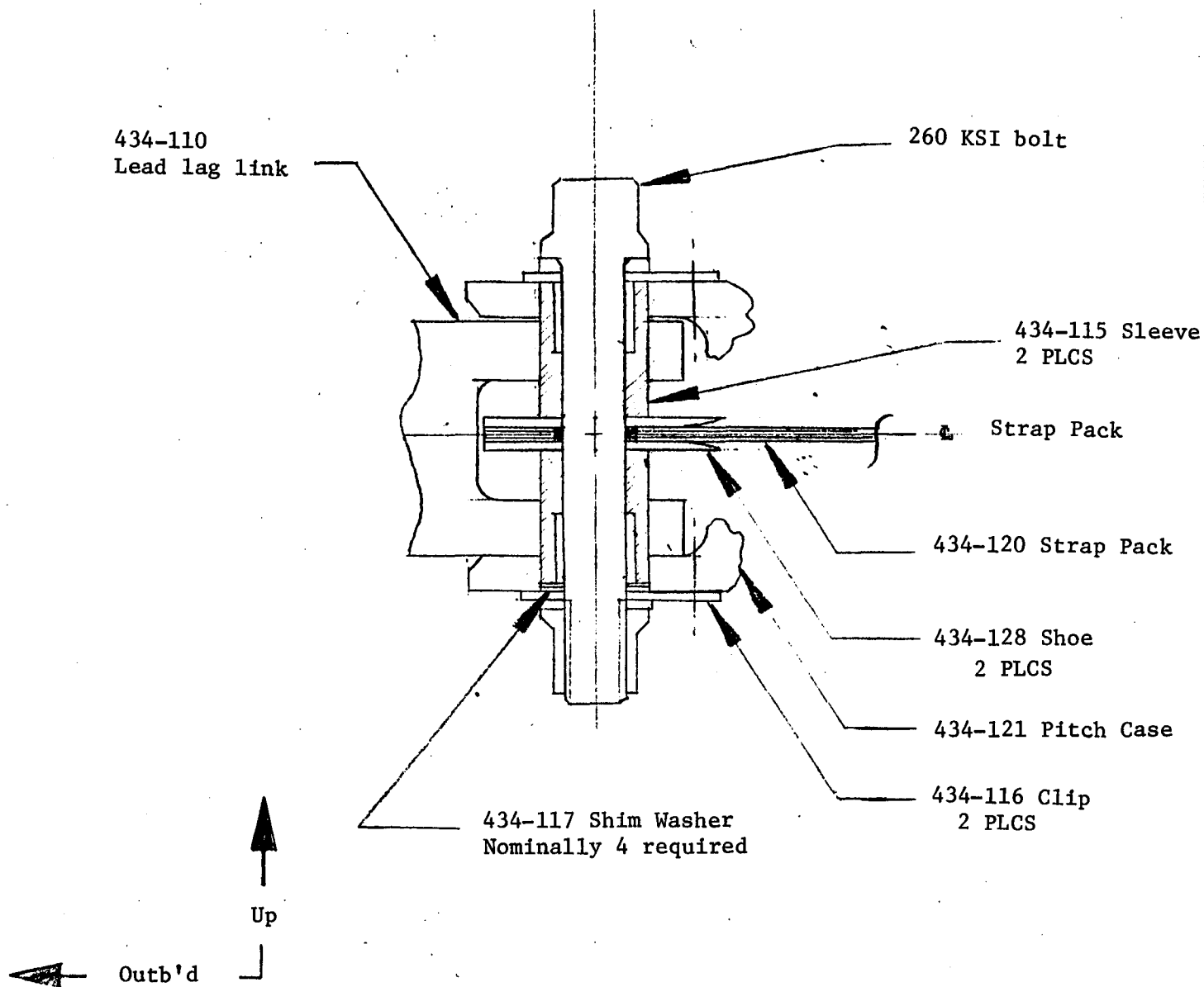
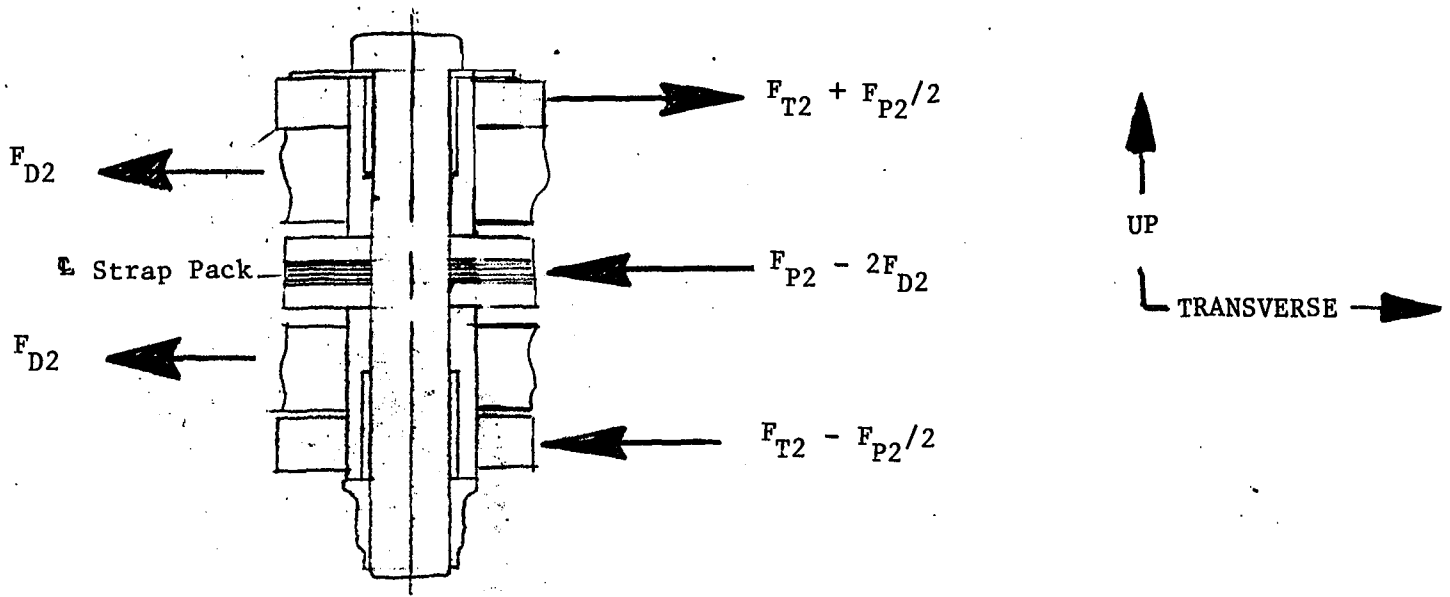
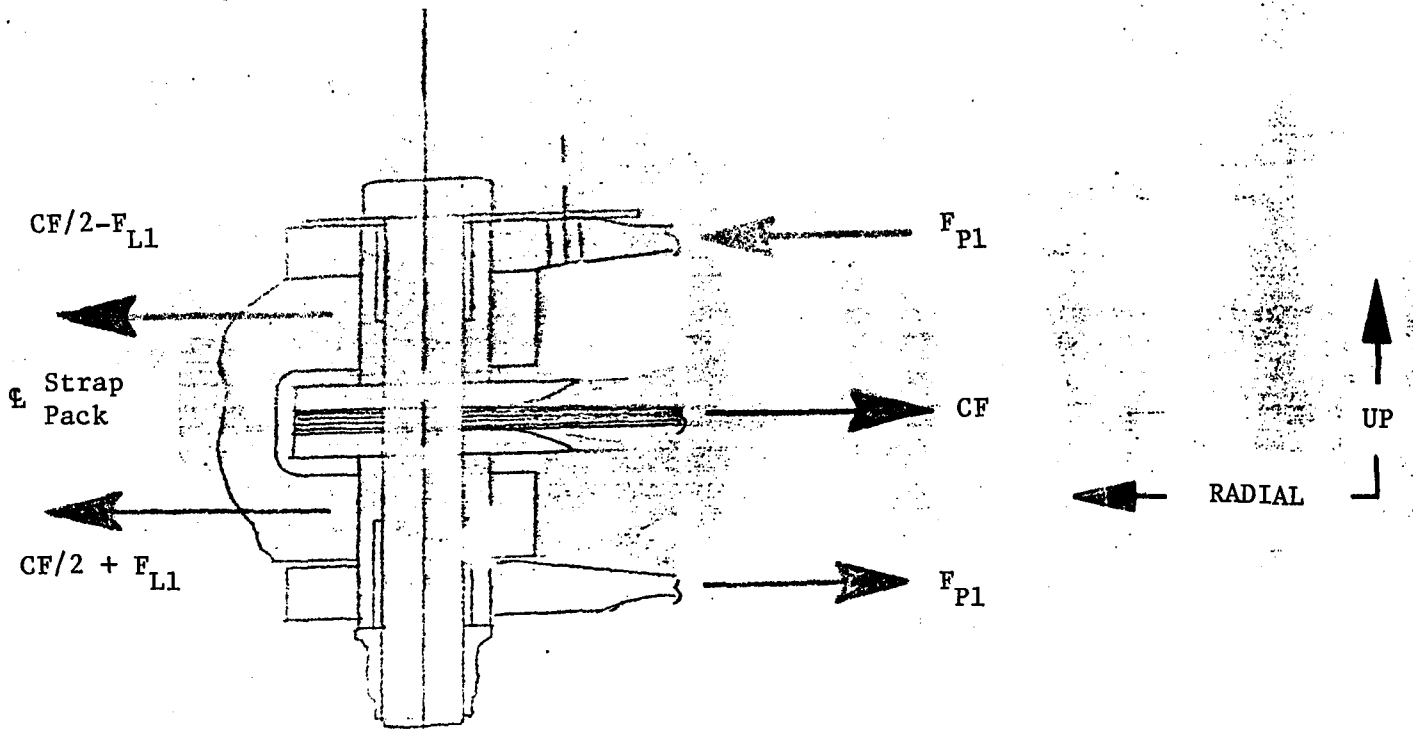

Figure 10.- Lead lag hinge assy. with 3/8 inch bolt (Scale 1:1)



TRANSVERSE  
FORCES  
(VIEW LOOKING INB'D)



RADIAL  
FORCES  
(REAR VIEW)

Figure 11.- Forces applied to lead lag hinge

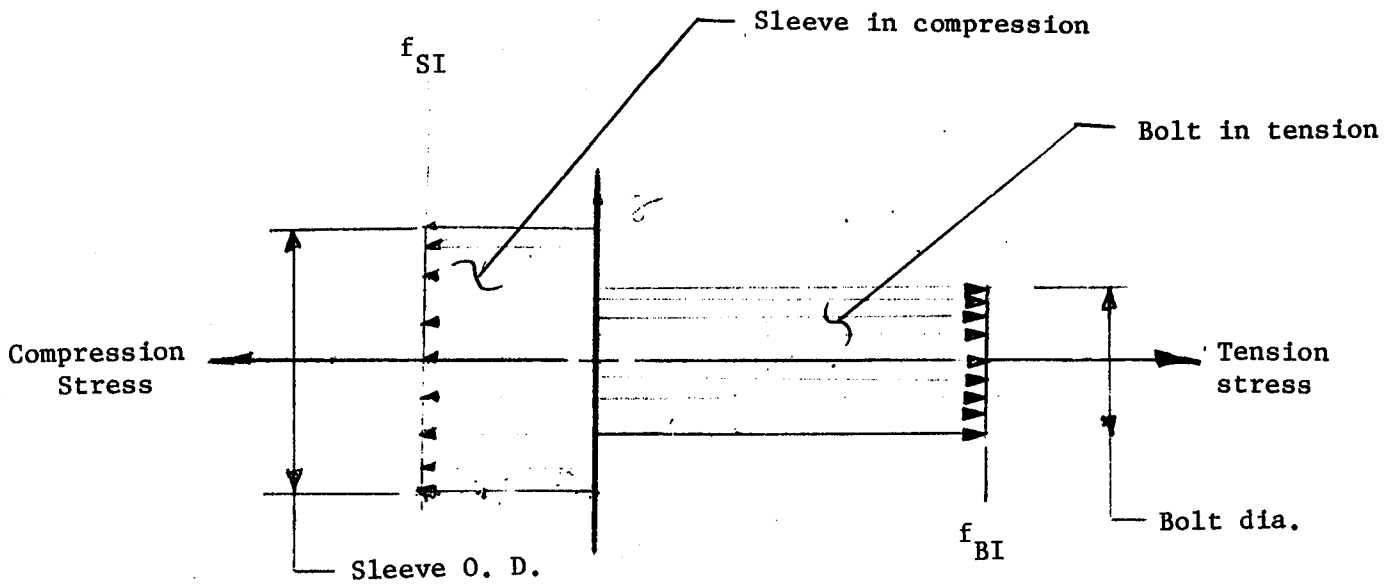

Figure 12.- Pre load stress.

STRESSES SHOWN IN PLANE OF BUSHING/STRAP-PACK-SHOE INTERFACE

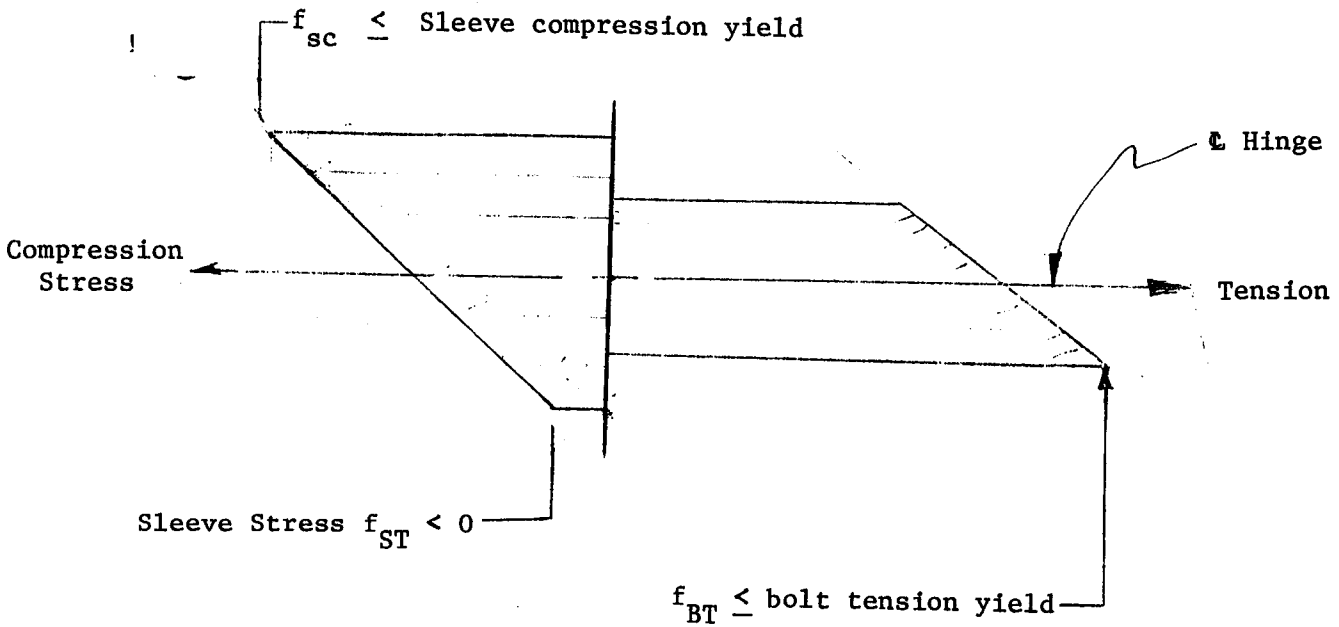

Figure 13.- Preload + bending stress constraints.

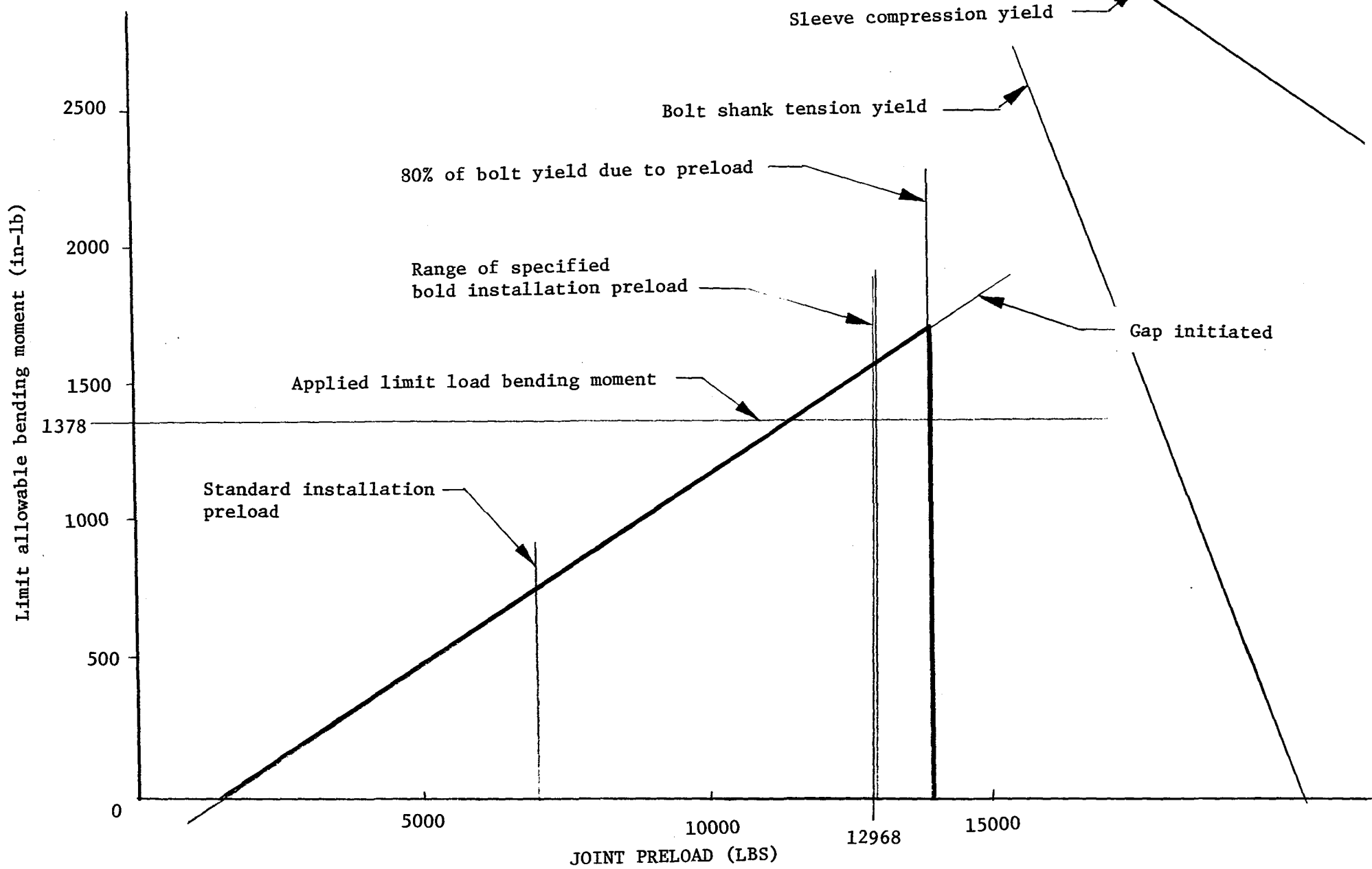

Figure 14.- Limit load bending constraints lead/lag hing assembly.

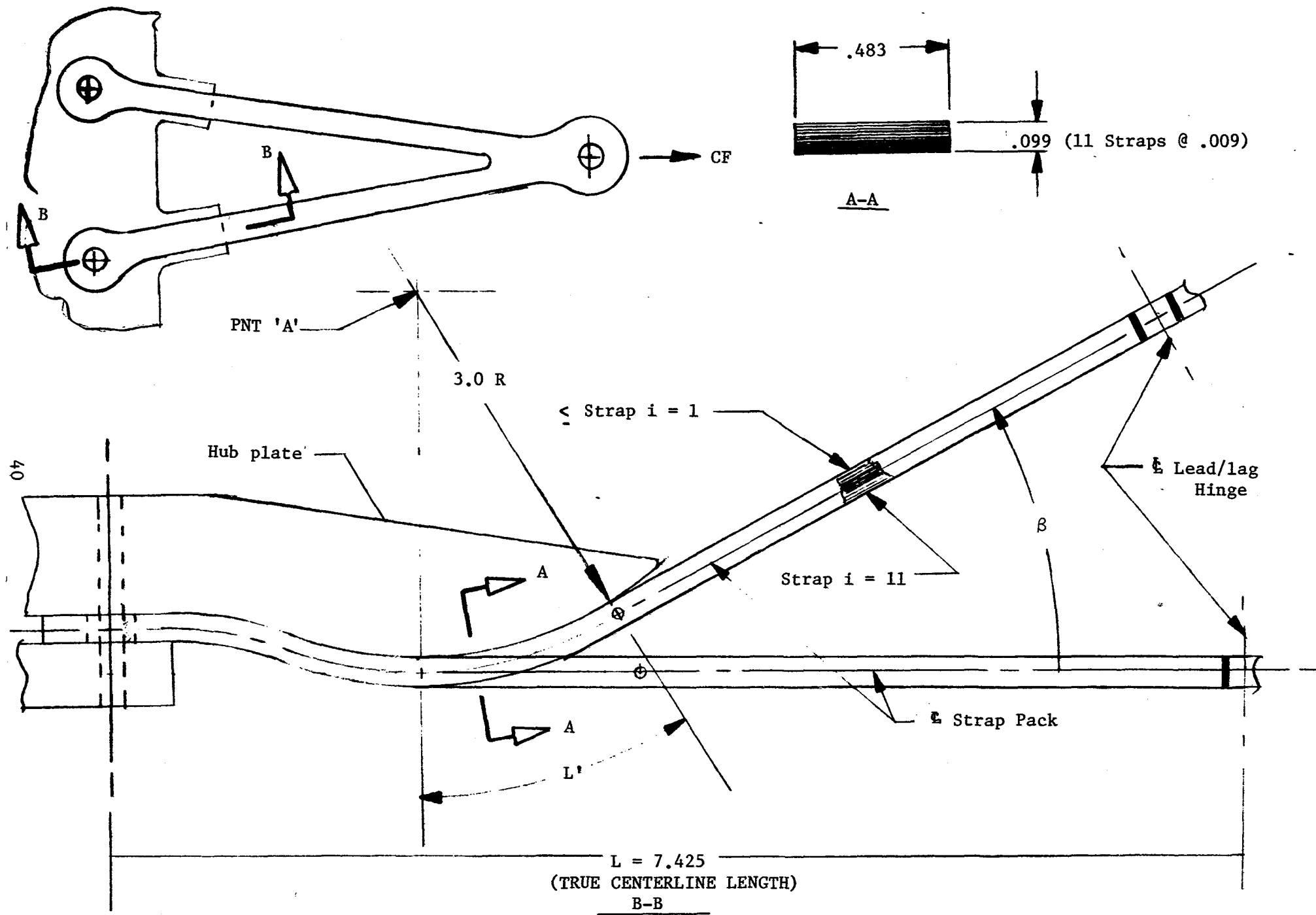
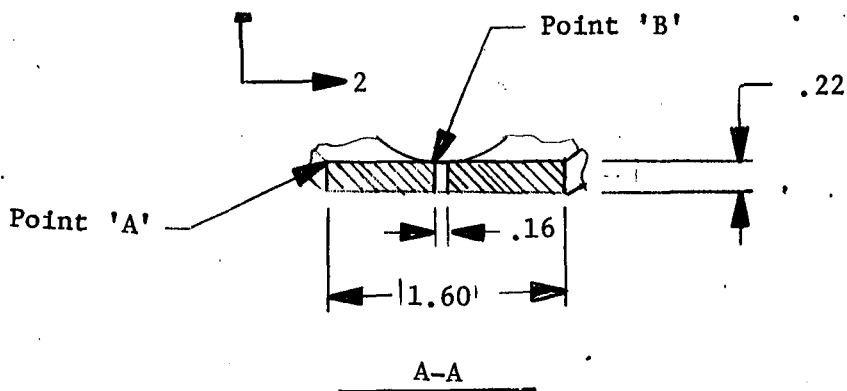

Figure 15.- Strap pack out-of-plane deformation (no scale)



**SECTION PROPERTIES:**

$$A = .317 \text{ in}^2$$

$$Z_2 = .0116 \text{ in}^3$$

$$Z_3 = .0938 \text{ in}^3$$

$$K_t \text{ AT 'A'} = 1.4$$

$$K_t \text{ AT 'B'} = 2.6$$

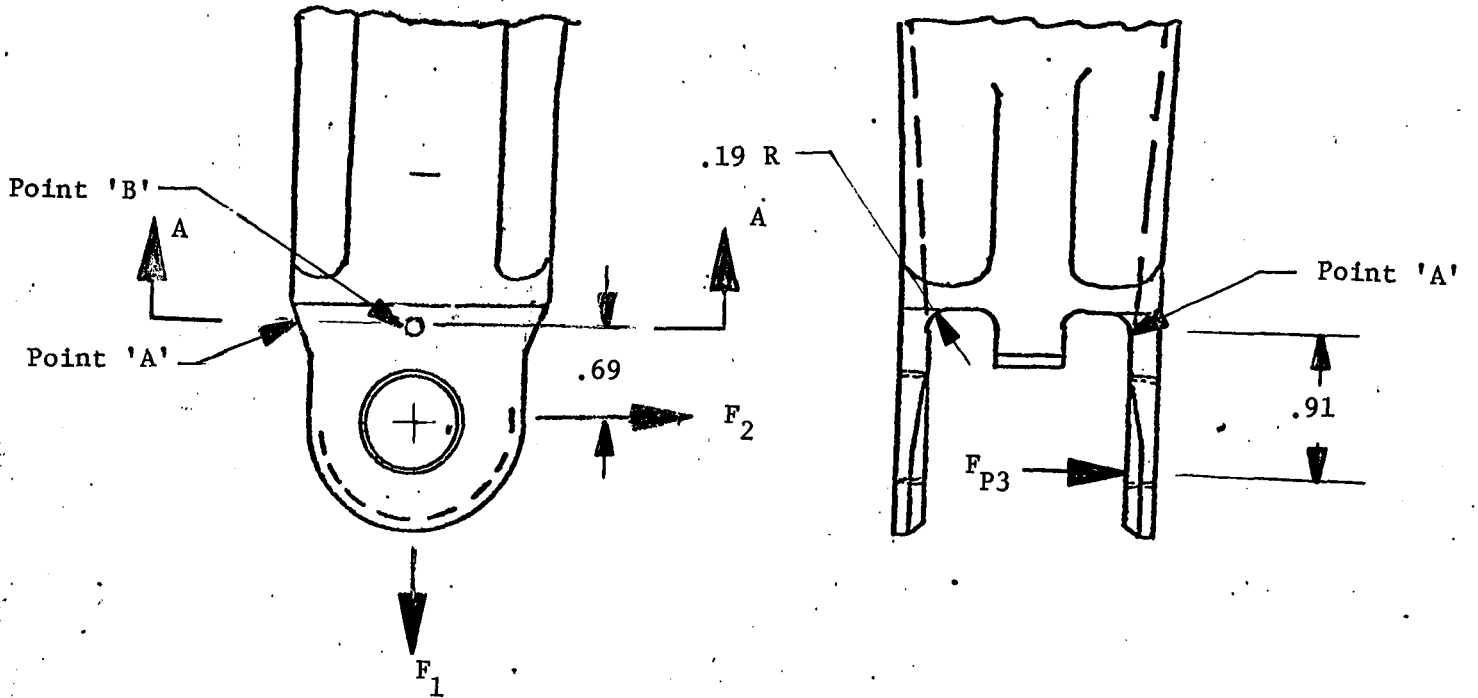

Figure 16.- Pitch case clevis

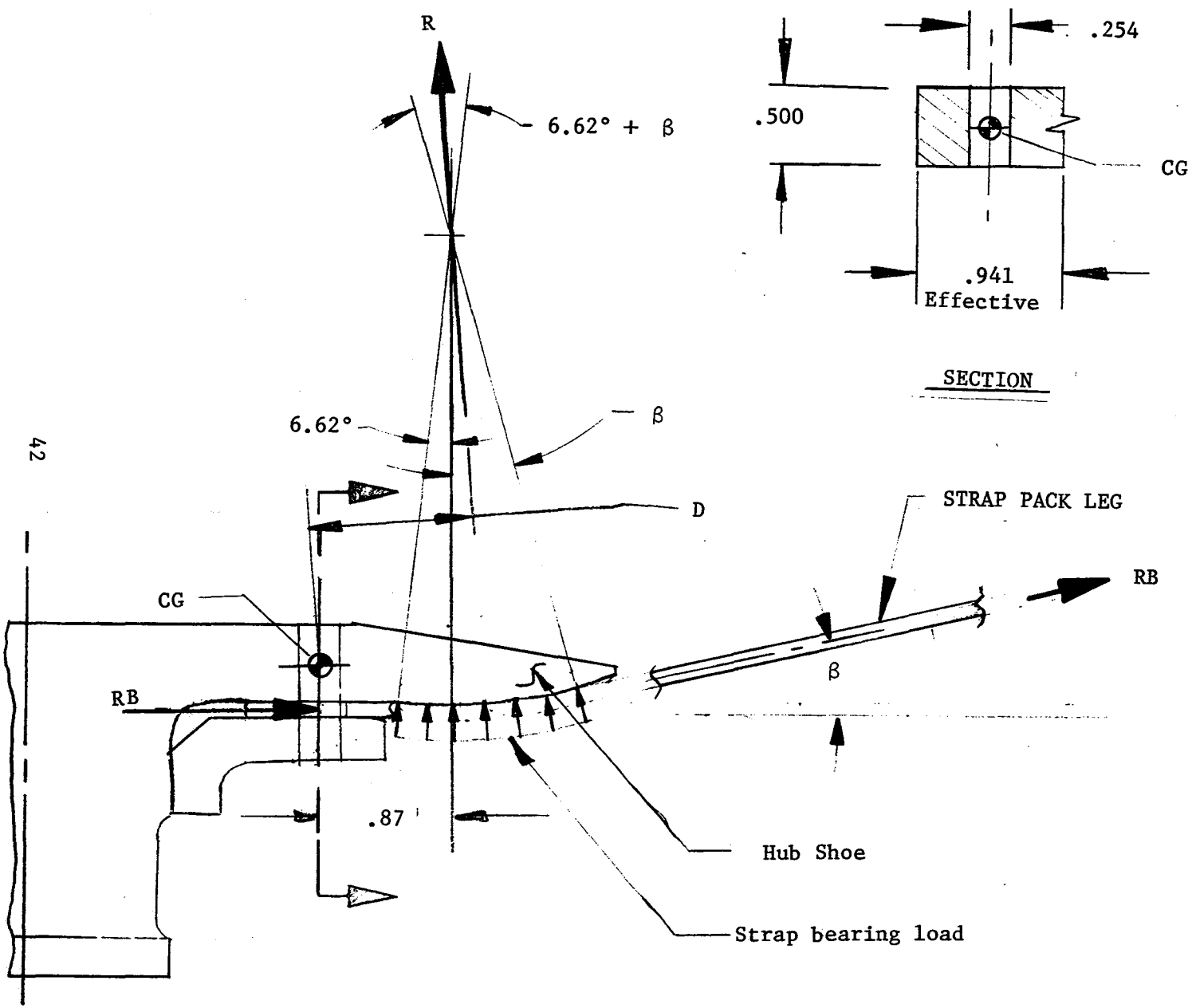

Figure 17.- Upper hub-shoe bending.



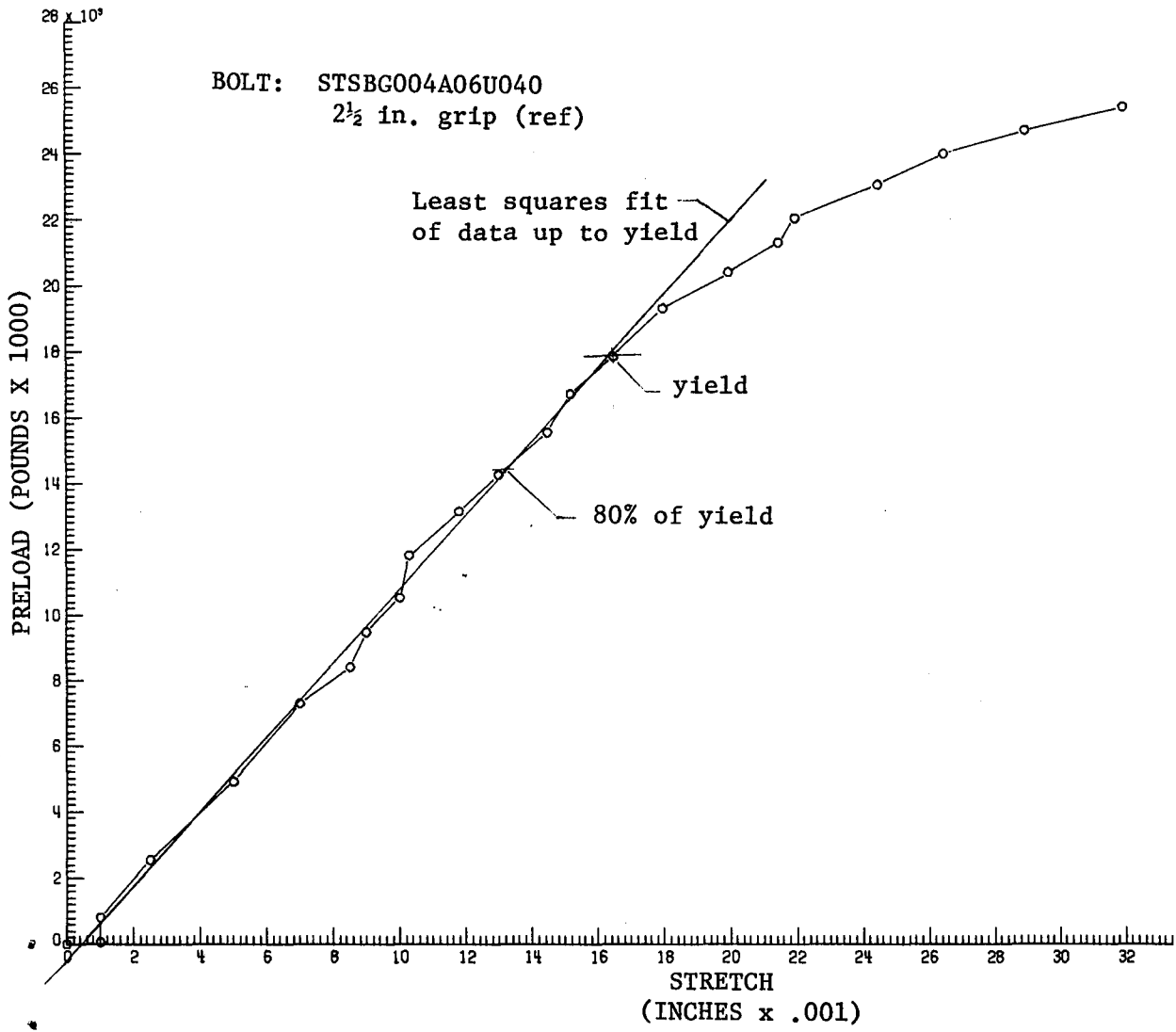
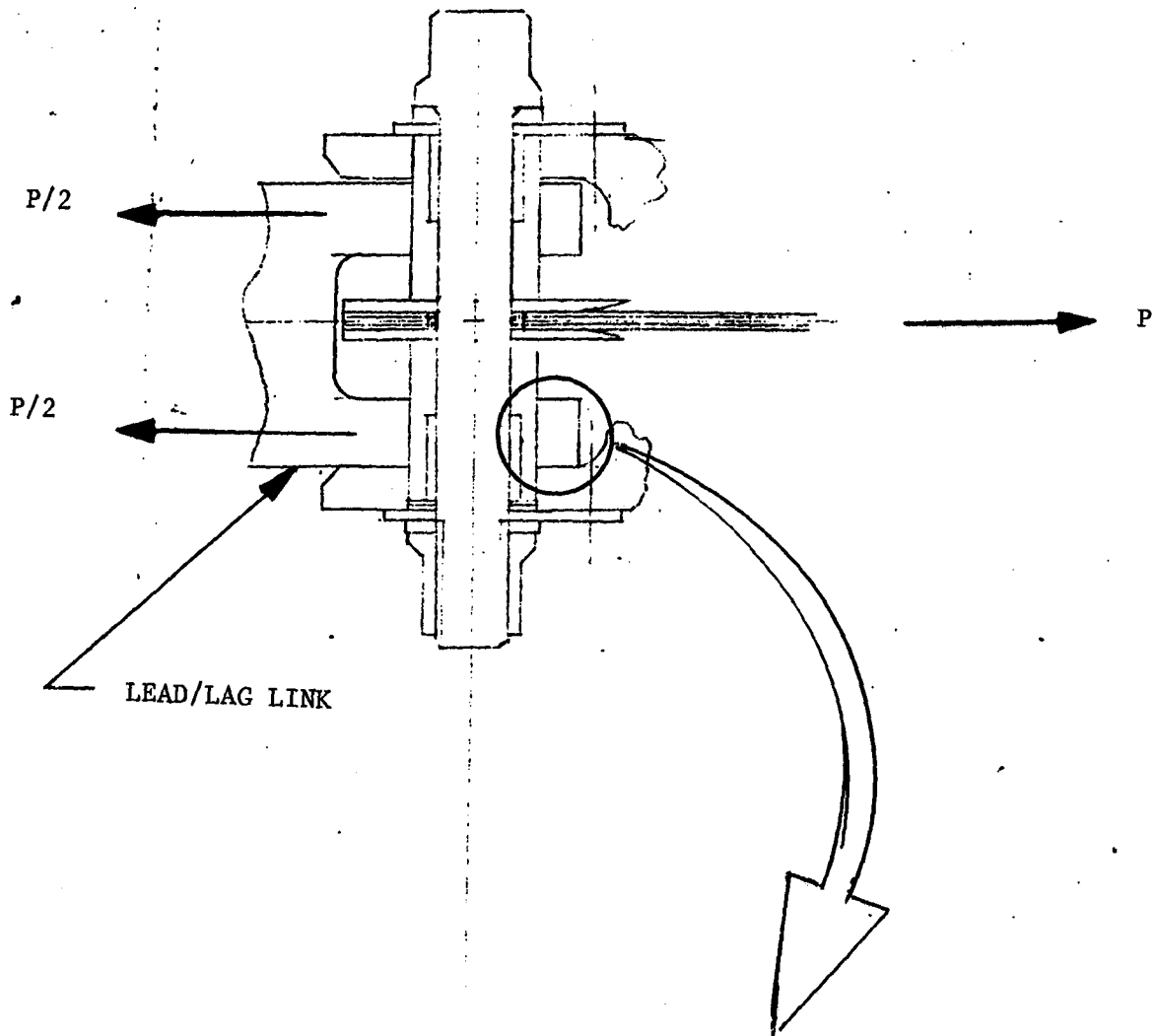
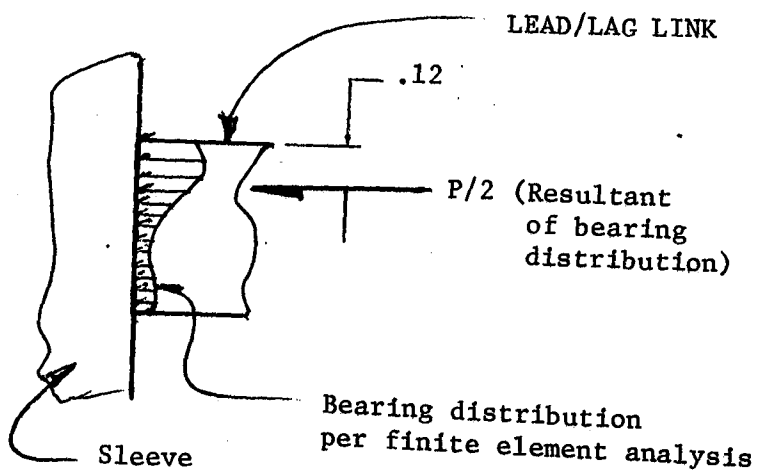

Figure 18.- Bolt preload versus deflection



LEAD/LAG LINK



LEAD/LAG LINK

$P/2$  (Resultant of bearing distribution)

Bearing distribution per finite element analysis

Sleeve

Figure 19.- Pin assembly bending loads



Standard Bibliographic Page

1. Report No. NASA TM-87625 AVSCOM TR 85-B-8		2. Government Accession No.		3. Recipient's Catalog No.	
4. Title and Subtitle Stress Analysis of 27% Scale Model of AH-64 Main Rotor Hub				5. Report Date October 1985	
				6. Performing Organization Code 505-42-39-24	
7. Author(s) Robert V. Hodges				8. Performing Organization Report No.	
				10. Work Unit No.	
9. Performing Organization Name and Address Aerostructures Directorate USAARTA-AVSCOM Langley Research Center Hampton, VA 23665-5225				11. Contract or Grant No.	
				13. Type of Report and Period Covered Technical Memorandum	
12. Sponsoring Agency Name and Address US Army Aviation Systems Command St. Louis, MO 63166-1798 and National Aeronautics and Space Administration Washington, DC 20546-0001				14. Sponsoring Agency Code	
				15. Supplementary Notes	
16. Abstract  Stress analysis of an AH-64 27% scale model rotor hub was performed. Component loads and stresses were calculated based upon blade root loads and motions. The static and fatigue analysis indicates positive margins of safety in all components checked. Using the format developed here, the hub can be stress checked for future application.					
17. Key Words (Suggested by Authors(s))  stress, model rotor hub			18. Distribution Statement  Unclassified - Unlimited  Subject Category 39		
19. Security Classif.(of this report) Unclassified		20. Security Classif.(of this page) Unclassified		21. No. of Pages 48	22. Price A03

For sale by the National Technical Information Service, Springfield, Virginia 22161



