

OXYGEN AND CARBON IN SILICON

J. W. Corbett

State University of New York at Albany
Albany, NY 12222

The properties of the early transistors were determined by the minority-carrier lifetime, as is the silicon photovoltaic solar cell. Most of the devices on the modern integrated circuits are majority carrier devices, in part to avoid this lifetime dependence. It is pertinent to note that the micro-electronics industry typically starts with wafers with a minority-carrier lifetime of ca. 1000 micro-seconds, but during device fabrication this lifetime is reduced to below ca. 1 micro-second, in spite of extraordinary cleanliness and precautions. Process-induced defects (PID) are the cause of this lifetime reduction, but PID is a rubric covering many poorly identified defects or unidentified defects. These defects include point defects, defect complexes, line defects, and bulk precipitates. We have some ideas about the nature of recombination at point defects and point defects complexes, but one of the aspects that needs to be understood is the nature of minority carrier recombination at line defects and at precipitates.

Some of the PIDs are known to be related to the fast-diffusers of the iron-series transition elements. One of the common techniques of dealing with these elements is "intrinsic" gettering by the oxygen precipitates. But even in the gettered state, there may be a residual effect on the lifetime.

Oxygen is an almost ubiquitous impurity in silicon and plays an important role in both integrated circuits and solar cells. The knowledge about oxygen in silicon will be reviewed. The isolated oxygen interstitial is electrically inactive, but in its various aggregated forms it has a variety of electrical activities. The impact of these defects on the minority carrier lifetime is unknown. The agglomeration and precipitation of oxygen, including impurity gettering and the complicating role of carbon, will be discussed.

The recent work on the thermal donors is providing a great deal of insight into the structure of the precipitates and has promise of leading to an understanding of the complex processes associated with oxygen in silicon. These results will be discussed.

PRECEDING PAGE BLANK NOT FILMED

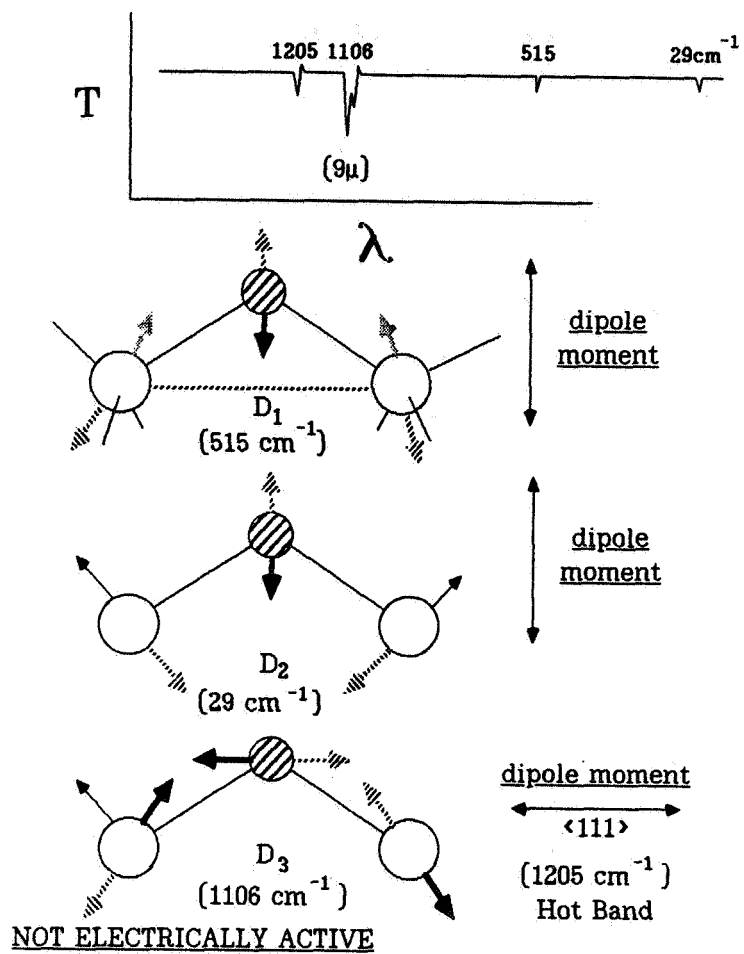

PRECEDING PAGE BLANK NOT FILMED

DEFECT INTERACTIONS

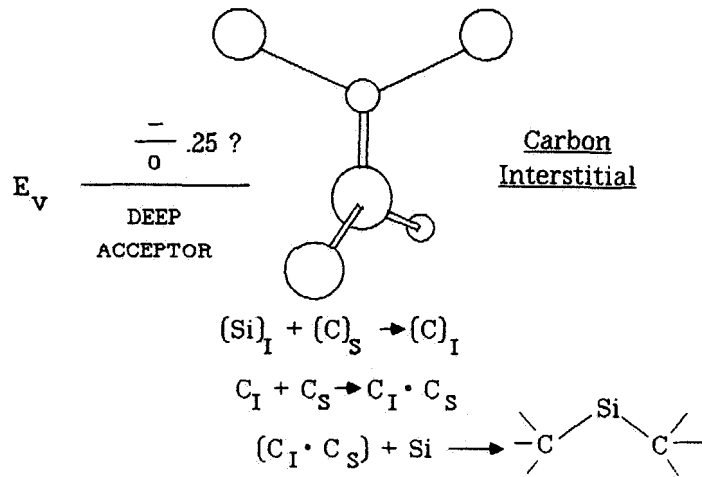
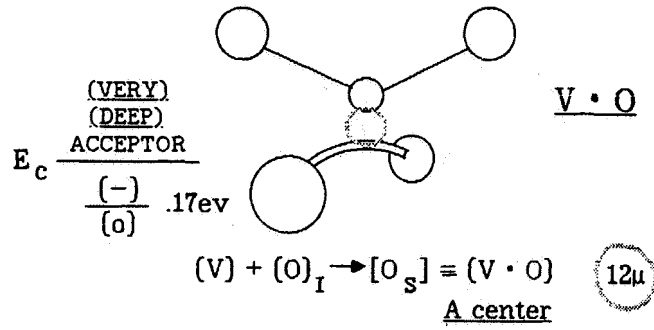

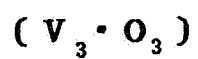
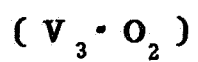
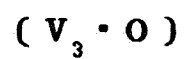
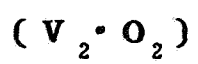
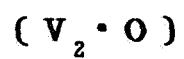
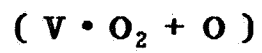
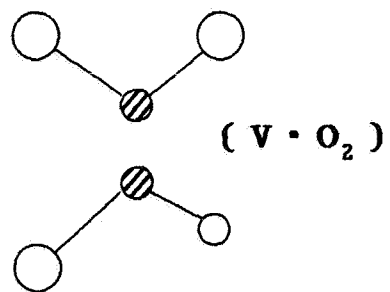

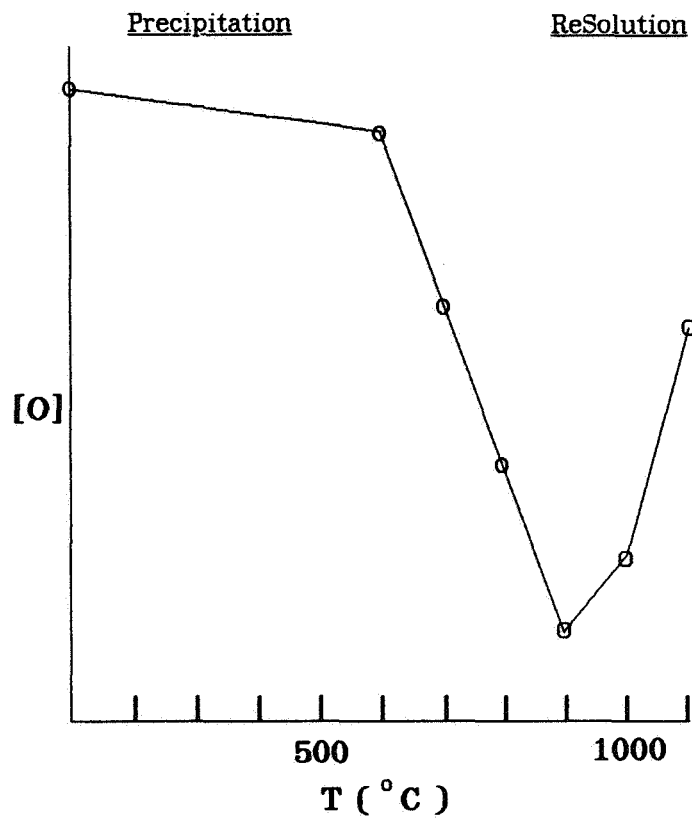

But this precipitation is very
COMPLEX

Precipitation at 450° C

THERMAL DONORS

(without carbon)

Hierarchy of DOUBLE DONORS
(at least 9)

Model

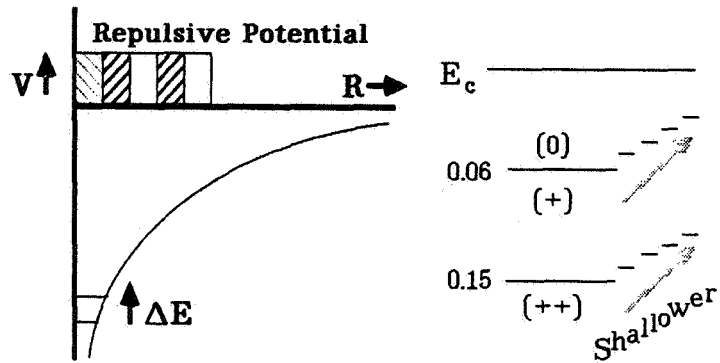
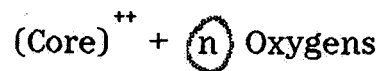

The volume of the repulsive potential grows w/ "n"

What's the core?
[How can oxygen make a donor?]

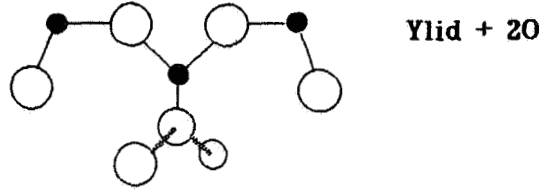

Ylid \equiv Split $\langle 100 \rangle$ [O • Si] Interstitial

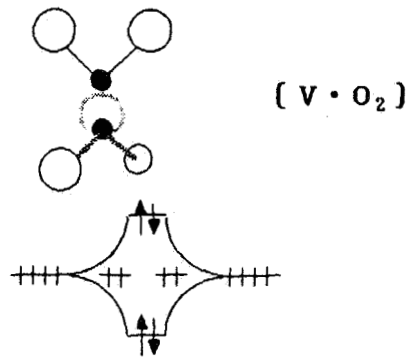

If these THERMAL DONORS have
OXYGEN ONLY,
does that mean that the
NUCLEATION IS *HOMOGENEOUS*?

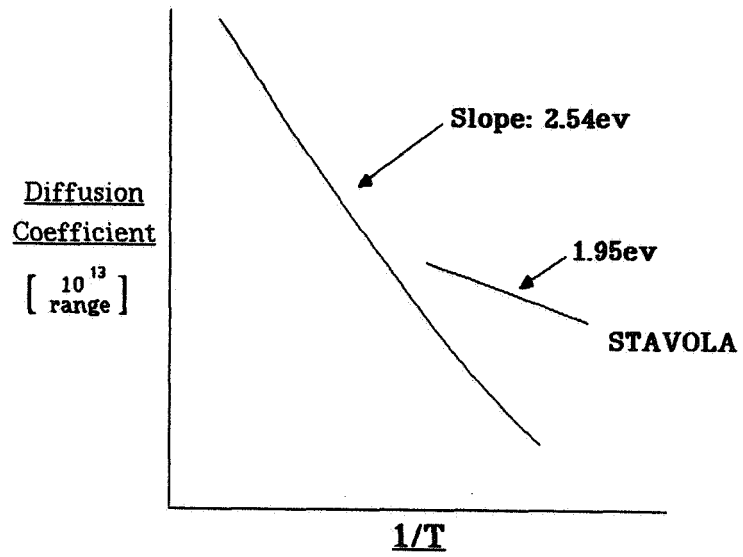

Vacancy Assisted?

Lindström
Svensson

*

(Still "NO" Carbon)

After 450 ° C Annealing
TEM

<110> Rods

Black Dots

(15%)

(85%)

After Annealing at 650 ° C,

The Thermal Donors

are

GONE

In the TEM?

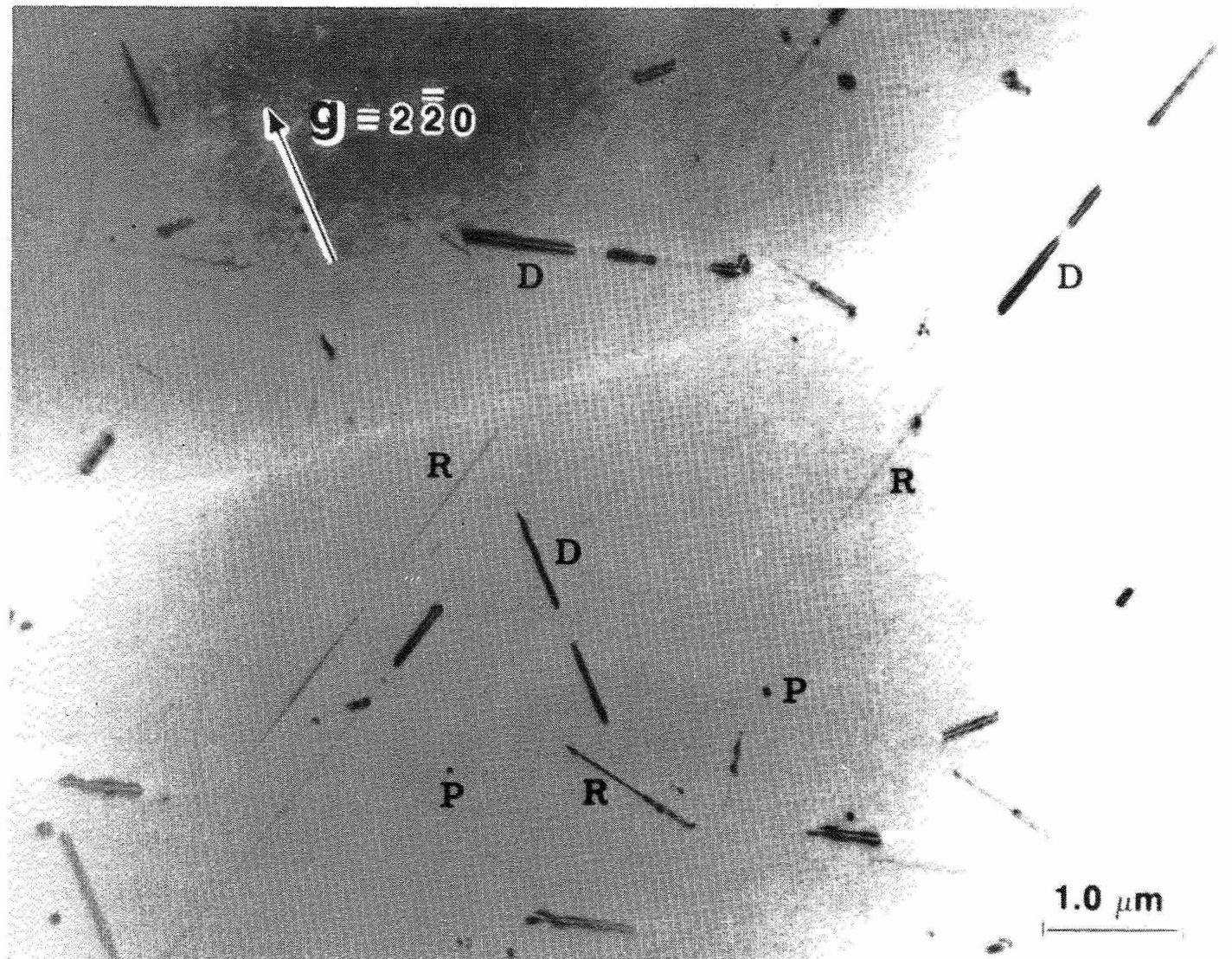

ORIGINAL PAGE IS
OF POOR QUALITY

Transmission Electron Microscopy of Heat-Treated Czochralski Silicon Showing "Rods" (Coesite Precipitates), Associated Dislocation Dipoles, and "Black Dots." CN. Yamamoto, P.M. Petroff, and J.R. Patel, *J. Appl. Phys.* 54 (1983) 231.

ORIGINAL PAGE IS
OF POOR QUALITY

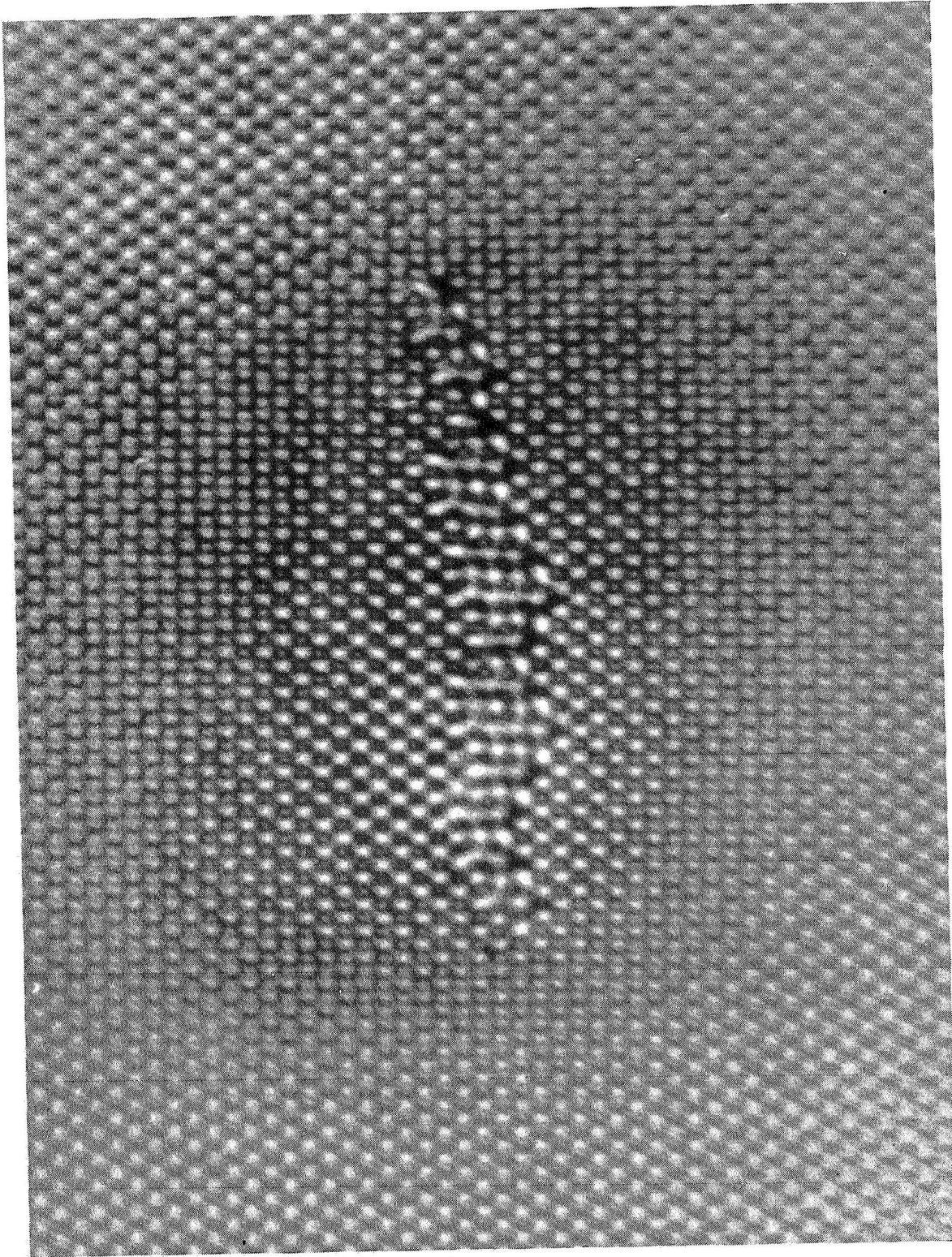

High-Resolution Transmission-Electron-Microscopy of an Oxygen Precipitate in Silicon, Showing the Coesite Structure of the Precipitate. From a. Bourret, J. Thibault-Desseaux and D. Seidman, "Early Stage of Oxygen Precipitation and Segregation in Silicon." J. Appl. Phys. 55 (1984) 825.

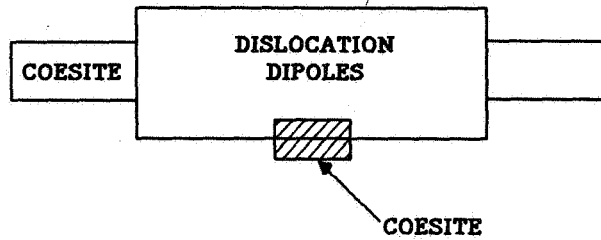

Indications are that during OXYGEN precipitation (and COESITE formation),

SILICON INTERSTITIALS
ARE EMITTED
(hence the dipoles)

And that this process happens even during the 450°C formation of Thermal Donors.

And during oxidation at high temperatures.

On annealing at higher temperatures

"Rods and Dislocation dipoles

DISAPPEAR

"Black Dots"

grow

into *AMORPHOUS SiO_x*

PLATELETS

After 1000°C Annealing

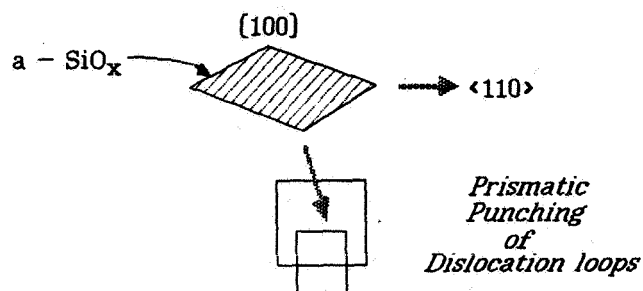

Annealing at 1200 °C

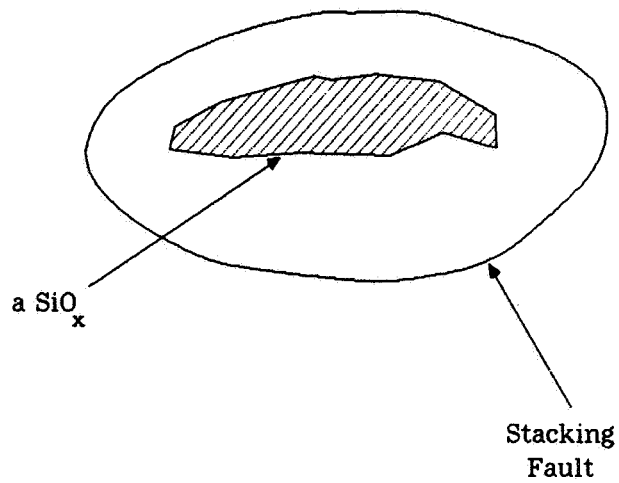

Cz - Si
WITH *CARBON*

THE 450 °C THERMAL DONORS
ARE *SUPPRESSED*

BUT

upon 600 °C annealing
NEW DONORS

seem to correlate with
BLACK DOTS

Remaining annealing seems the SAME.

Does that mean that all the Black Dots

($a-SiO_x$ ppt s)

are HETEROGENEOUSLY (C)

NUCLEATED?

What else does CARBON do?

From ribbon - Si => (SiC) ppts.

Not (yet) in crystal - Si

(C • III) pairs

Lots of (C • O) Infrared bands.

(V • C • O) = K center p-type damage



C in "A and B swirls"

Carbon outdiffuses just like Oxygen.

denuded zone

low O and C

if temperature is right

WHY should the SOLAR

CELL Industry care

about these problems?

Wafer Source	<i>LIFETIME</i>
Cz	$\approx 10 \mu\text{sec}$
Fz	$\approx 200 \mu\text{sec}$

Both $\ll 10,000 \mu\text{sec}$.

J. O. BORLAND
ECS, Spring 1983

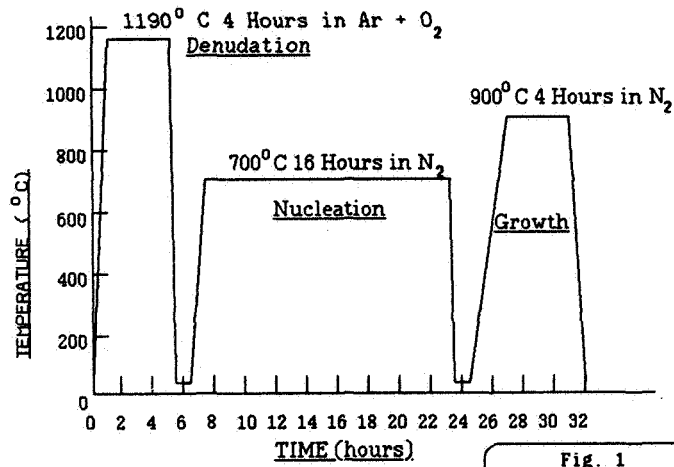

Fig. 1
 3-step intrinsic
 gettering cycle.

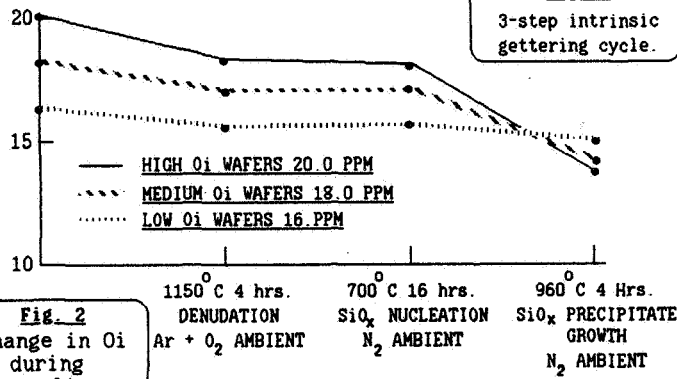

Fig. 2
 Change in O_i
 during
 annealing.

MOS Cvst lifetime

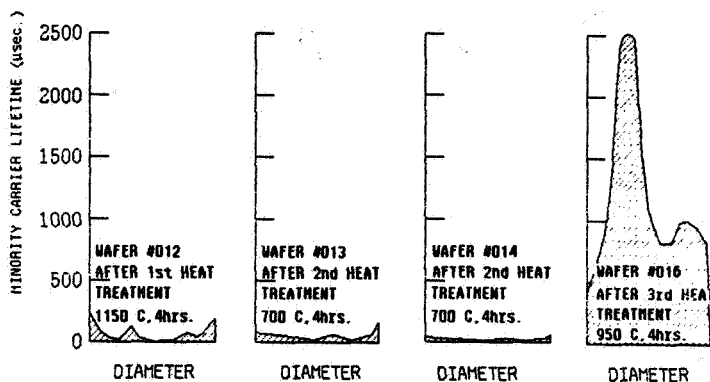

Figure 6.

MOS C-t lifetime comparison of adjacent high O_i wafers.

J. O. Borland
ECS, Spring '83

What's the problem?

Grown-in defects
{Recombination centers
Katsuka (luminescence)} } *NOT the big problem!*

Process-induced defects } *the bigger problem!*

Fast diffusers

Fe, Ni, Cr, Cu, Au, ...

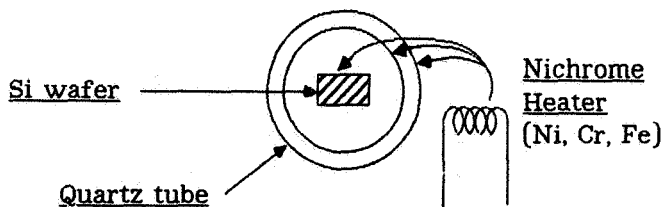

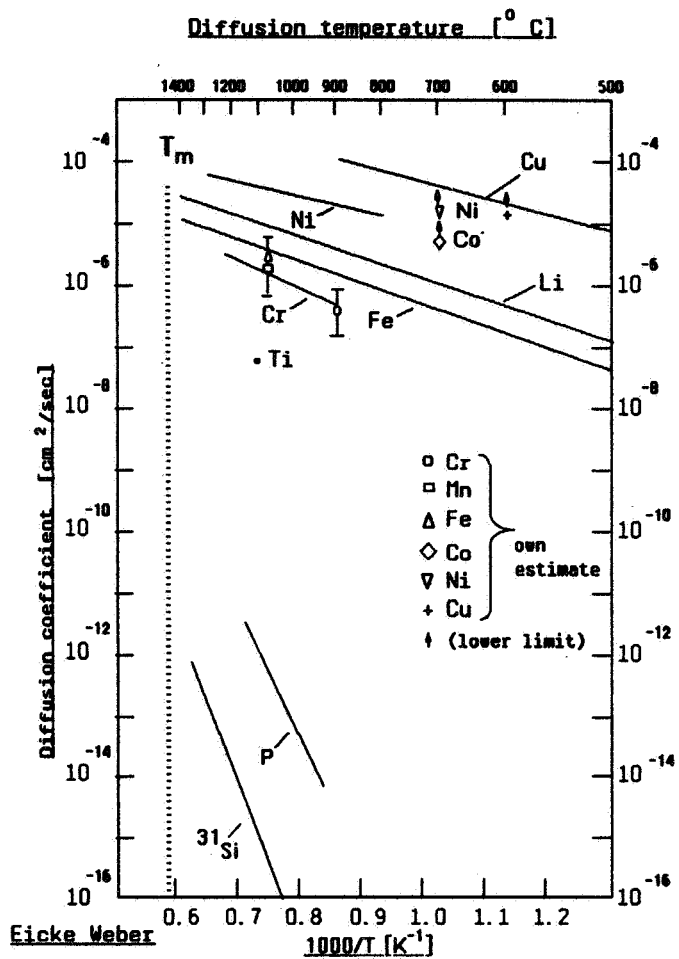

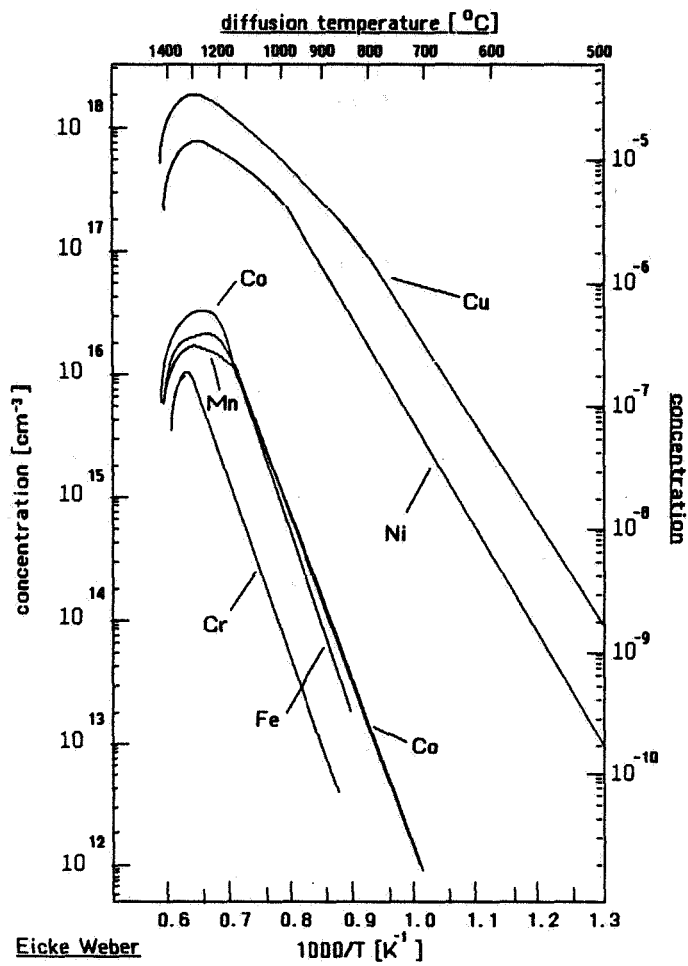

Quenched in Fe (EPR)

(Fe) – Interstitial at T_d

(Fe • B), (Fe • Al), (Fe • In) pairs

(Fe • C) pair

(Fe)₄

Similar results for Cr, Mn.

Ni, Co, Cu

too fast to catch.

WHAT CAN BE DONE?

GETTERING

Internal gettering at oxygen ppts and associated defects.

Jastrzebski Cu, Ni, @ SF's
IBM Cu @ Oxide ppts.
Futagami "Heavy metals" at SF's.

*But we know ALMOST NOTHING
about these states.*

These are NOT EQUILIBRIUM states.

Remember COESITE is a HIGH PRESSURE phase.

Ourmazd: Ni: in Guinier-Preston phase.
Fe: tetragonal silicide phase.

Back Surface Gettering

*Damage
Diffusion*

(maybe useful for solar cells)

What ELSE can be done?
[Micro-electronics Industry]

CLEAN ROOM and
Extraordinary Cleanliness

RF Heating } Keep environment
Heat Lamp Heating } COLD.

Change Processing Tubes from SiO_2
to Silicon (SiC liners).

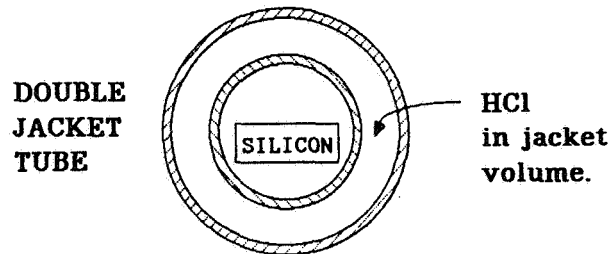

Form Volatile Chlorides.

Interstitial Nitrogen?

An Aside:

Substitutional Nitrogen
is a *DEEP DONOR*

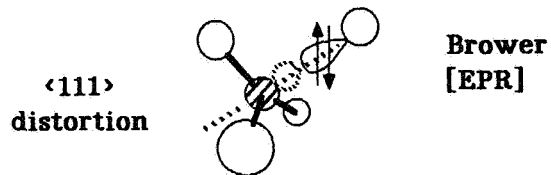

The electrically inactive
nitrogen "must" be a
COMPLEX.
(N-B)?

MRS Symposium:

"Selected Impurities in Silicon:

O, C, H, and N"

2-6 December, 1985 Boston

DISCUSSION

- ELWELL: Do you believe that the vacancy-assisted diffusion is what's leading to precipitation of oxygen in silicon for the thermal donors, or do you believe that precipitation is vacancy-assisted? Have you ever studied that by comparing the defects you get by ESR for a slice taken from the top of a Czochralski wafer, where you are subject to a lot of fluctuations, as compared with the early stage of precipitation in a wafer grown in a magnetic field, where you think the interface is much more quiescent during growth?
- CORBETT: No, it has not been studied to the extent that I think it should be. We do know a good bit about many of these vacancy interactions, but there is a great controversy raging about what's going on with silicon self-diffusion.
- CISZEK: Could you elaborate a little bit on your views of how the carbon and the silicon interstitials are interacting in forming the B-type swirl defect in float-zone silicon?
- CORBETT: My own opinion would be the entrapment of liquid in the growth. The liquid is more dense than the solid and it is simply captured and ends up as a material-rich region that throws them into it.
- CISZEK: Do you have any comments, Dr. Abe? I would be very interested in perhaps your latest ideas of what may be going on in that interaction of carbon in self-interstitials.
- KALEJS: [Question addressed to Dr. Abe] What is your current thinking about how the B-swirl may be formed from carbon and silicon self-interstitials?
- ABE: I think these are pre-stages of an A-swirl that are not closely related to the carbon impurity.
- CORBETT: Can you denude a zone of A and B swirls?
- ABE: A and B swirls consist of silicon interstitials. Silicon interstitials diffuse out from the surface so you can perhaps make a denuded zone.