

Description of Concept and First Feasibility Test Results of a Life Support Subsystem of the BOTANY FACILITY Based on Water Reclamation

Helmut R. Löser

MBB/ERNO Raumfahrttechnik GmbH

Bremen, West Germany

ABSTRACT:

The BOTANY FACILITY allows the growth of higher plants and fungi over a period of 6 months maximum. It is a payload planned for the second flight of the EURECA platform around 1990.

Major tasks of the Life Support Subsystem (LSS) of the BOTANY FACILITY include the control of the pressure and composition of the atmosphere within the plant/fungi growth chambers, control of the temperature and humidity of the air and the regulation of the soil water content within specified limits.

Previous studies have shown that various LSS concepts are feasible ranging from heavy, simple and cheap to light, complex and expensive solutions. In the first part of the paper a summary of those concepts is given. In the second part a new approach to accomplish control of the temperature and humidity of the air within the growth chambers is described which is based on water reclamation. This reclamation is achieved by condensation with a heat pump and capillary transport of the condensate back into the soil of the individual growth chamber.

Part three provides some analytical estimates in order to obtain guidelines for circulation flow rates and to determine the specific power consumption.

The design of a water reclamation module is described in part four while the test hardware is illustrated in part five. Part six describes the test set-up while in the seventh and last part of the paper the test results are summarized and discussed.

1. INTRODUCTION

One of the core experiments of the second flight of EURECA (= European RETrievable CArrier) currently scheduled for 1990 is the BOTANY FACILITY (BF) which is a plant growth chamber designed to accommodate various experiments with plants and/or fungi. Table 1 summarizes the BF performance data with the emphasis laid on the functions the life support subsystem (LSS) has to fulfill.

Purpose	Growth of higher plants and fungi from seed to seed and spore to spore
Carrier	EURECA
Mission duration	6 months maximum
Features	<ul style="list-style-type: none"> • 12 micro gravity cuvettes • 6 1g control cuvettes • Illumination • Video • Data acquisition • Pollination device • Fixation device
Life support subsystem functions	<ul style="list-style-type: none"> • Contamination control • Air humidity control • Control of soil water content • Control of atmospheric pressure • Control of composition of atmosphere
Developmental status	<ul style="list-style-type: none"> • Phase B study completed • 1. flight on • 2. EURECA mission
BOTANY FACILITY performance data	

Table 1: BOTANY FACILITY performance data

Reprinted with permission © 1985
Society of Automotive Engineers, Inc.

An impression of the BF geometry existing at the end of the phase A study can be gained from Fig. 1.

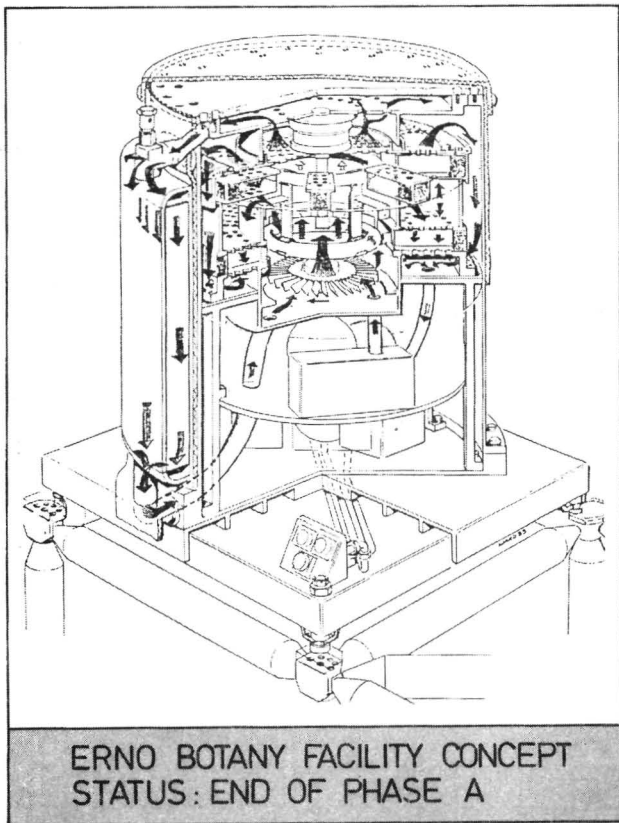

Fig. 1: ERNO BOTANY FACILITY CONCEPT STATUS: END OF PHASE A

Early in the study it turned out that the LSS conveniently should be divided into a Ventilation And Soil/Air Humidification (VASAH) loop and an Atmosphere Storage And Composition Control (ASACC) loop. For each of them a number of options have been described and discussed in a previous paper, see (1)*. For each set of options a trade-off was conducted considering aspects such as

- o Weight
- o Technical complexity
- o Critical components
- o Compatibility with microgravity environment
- o Costs

resulting in the recommended options (status end of phase A) which are depicted in Fig. 2 and 3.

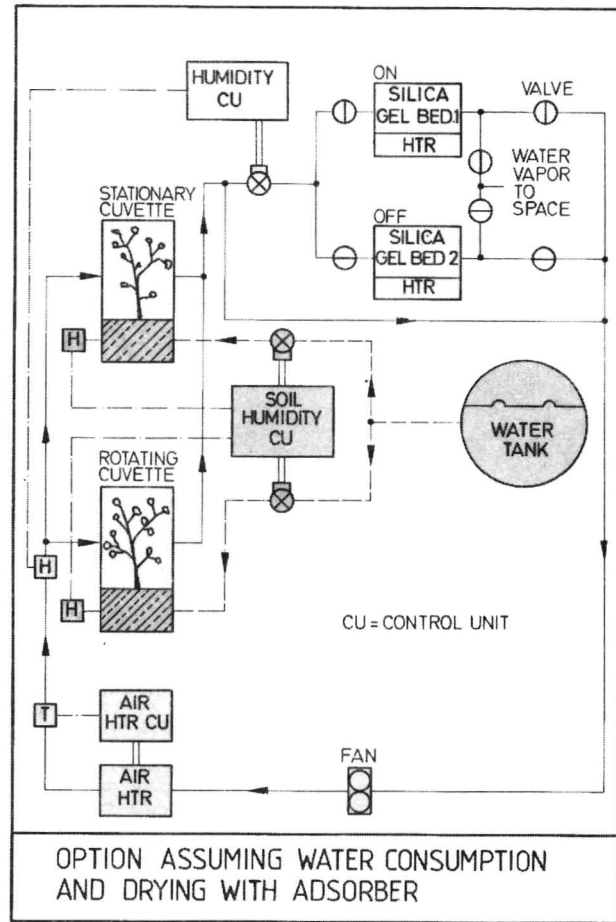

Fig. 2: VASAH loop option based on water adsorption in a regenerable Silica-gel dryer

* Numbers in parenthesis designate references at end of paper

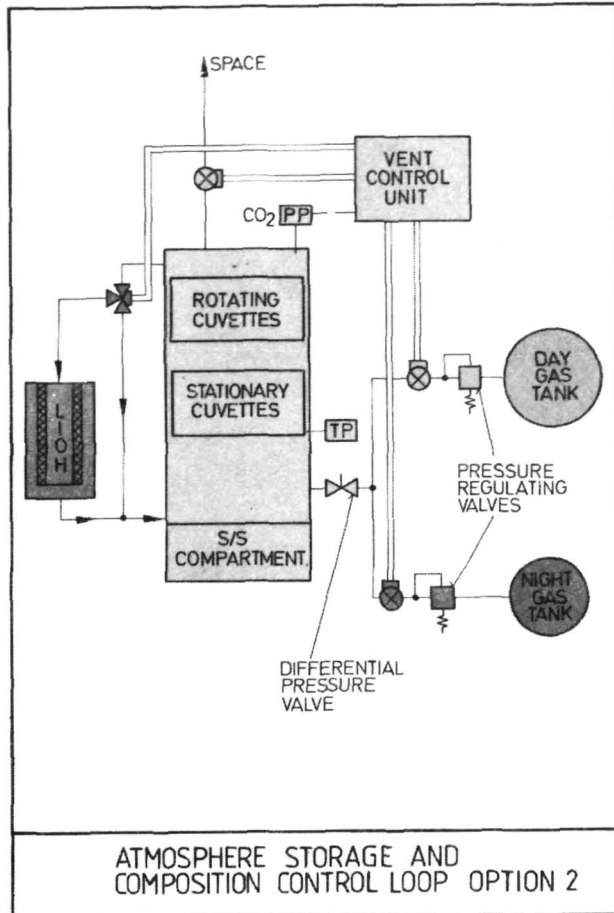

Fig. 3: ASACC loop option using day and night gas tank in combination with Lithiumhydroxide cartridge

As can be seen from Fig. 2 water is stored in a water bladder tank and is at the begin of the growth period allowed to moisten the soil by means of the soil humidity control unit (which can be part of the on-board data handling system). For that purpose soil humidity sensors are used which cause the watering valve of a particular cuvette to close in case the desired soil water content has been reached. Obviously, each cuvette needs its own sensor because different plants or plant sizes might cause different water consumption/resupply.

The water evaporated by the surface of the soil or a solution containing nutrients (AGAR) and the plant is carried away by the air circulating through the cuvettes and an air humidity sensor controls the position of a bypass valve allowing a certain amount of air to flow through the active Silicagel bed. Active designates the bed which is not regenerated. By adsorption the Silicagel removes a certain fraction of the water contained in

the air with the result that the air leaving the bed is very dry. By mixing that air flow with the bypassed flow the desired humidity at the inlet of the cuvettes is achieved. The air returning to the cuvettes passes through a fan which provides the necessary differential pressure to overcome the pressure loss of the various loop components.

In order to achieve a close temperature control the air passes through a heater before it returns to the cuvette.

To avoid cross-contamination of the various cuvettes at the inlet and the outlet of each cuvette a sterile filter is positioned (not shown in Fig. 2).

After a certain time interval the adsorption capacity of a dryer bed is reached and it will be isolated from the loop by means of solenoid valves. The second bed - which in the meantime has been regenerated by the combined effect of space vacuum and elevated temperature - is connected with the loop and takes the function of the first bed.

The function of the ASACC loop is discussed in detail in (1) and shall not be addressed here.

2. CONCEPT OF WATER RECLAMATION

As will be noticed, the VASAH concept illustrated in Fig. 2 is based on water consumption which means that all the water needed during a mission has to be considered as a consumable.

Apart from the resulting weight penalty the concept is fairly complex, in particular the water supply to the rotating cuvettes located in the control centrifuge will not be an easy task.

Therefore the concept based on water reclamation was re-evaluated which had been addressed already in (1) but was rejected due to its apparent complexity.

Fig. 4 illustrates in a schematic form the concept of internal water management.

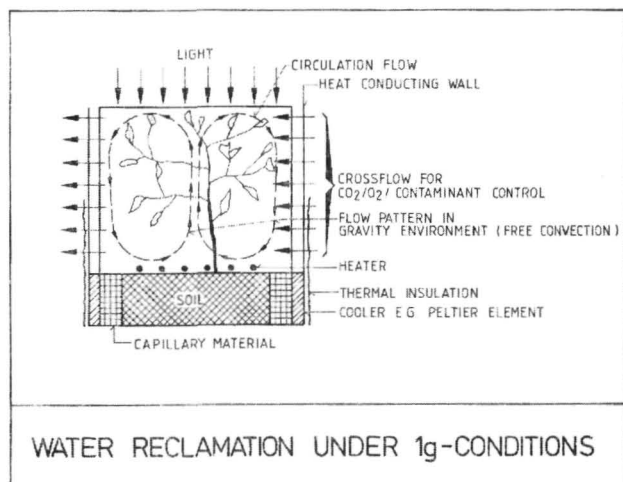

Fig. 4: Cuvette with closed water loop feasible for 1 g-environment

As can be seen, the lower portion of the cuvette sidewalls is manufactured from a material having a good thermal conductivity and is connected with a cooler, e.g. a Peltier element. The cooler in turn is in contact with the soil by means of a capillary material. Atop of the soil several heater wires are installed, however, tests may prove that they are not required.

The light input and - if required - the heat liberated by the heater wires will warm up the air in the center position of the cuvettes and it will rise due to the density difference. At the cooled sidewalls the opposite effect will establish and as a result a circulation pattern should prevail as illustrated in Fig. 4.

When the air is progressively cooled along the sidewalls, condensation will occur and the water droplets formed will drip into the capillary material (wick) which allows the water to return to the soil.

The air flowing across the soil surface and passing the heater wires is comparatively dry such that the plant (and the soil surface) will evaporate water by taking it from the soil.

As can be seen, a closed water loop with two phase changes should form: In the plant's leaves from liquid to vapour state and at the condenser from vapour to liquid.

The air humidity in the cuvette can be controlled for a given plant size by varying the power applied to the Peltier element.

Under microgravity conditions the air flow pattern caused by density differences disappears and one has therefore to replace free by forced convection by installing a fan. A conceivable arrangement is shown in Fig. 5.

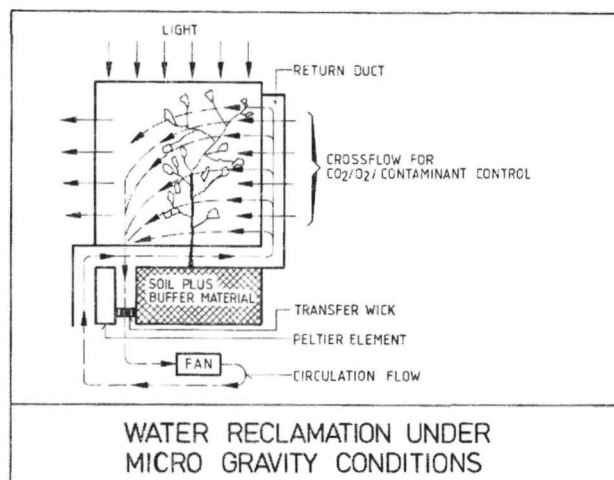

Fig. 5: Cuvette with closed water loop feasible for microgravity environment

When compared to Fig. 4 there are 7 modifications depicted in Fig. 5:

1. A ducting system for the supply of dry air to the cuvette and the return of wet air to the condenser.
2. Installation of a mini fan to overcome the pressure loss of the ducting system.
3. Deletion of heater wires.
4. Thermal decoupling of sidewalls from the condenser.
5. Modification of the condenser such that a good thermal contact exists between its surface and the air flowing past it.
6. Introduction of a transfer wick which allows the transport of the condensate from the condenser to the soil.
7. Installation of regenerative heat exchanger to reheat the air leaving the condenser to cuvette temperature by using a portion of the waste heat of the Peltier element (not shown in Fig. 5).

The major difference relative to the concept feasible under 1 g-conditions is the use of capillary forces in order to separate the condensate from the air in the concept for microgravity conditions.

If one compares the concept of Fig. 5 with the option 4 depicted in Fig. 8 of (1) one will recognize in the condenser of Fig. 5 the condensing heat exchanger of Fig. 8 of (1) and in the transfer wick of Fig. 5 the water separator of Fig. 8 of (1).

851397

Apparently a number of flow patterns are possible for the microgravity cuvette as shown in Fig. 5. For example the kinds illustrated in Fig. 6a-c can be imagined.

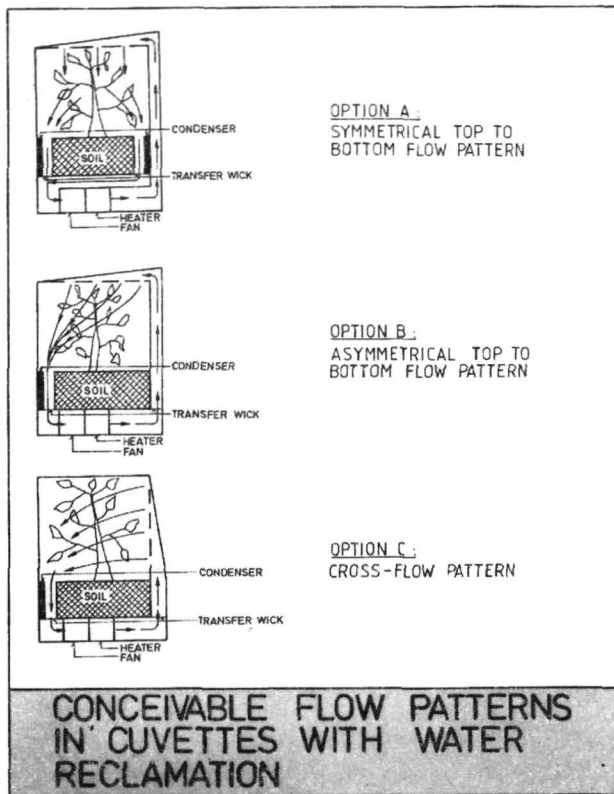

Fig. 6: Conceivable flow patterns for a microgravity cuvette with water reclamation

The most sophisticated pattern is that shown in Fig. 6a. Since it is symmetrical it requires 2 condensers and 2 transfer wicks. Another disadvantage is seen in the fact that the top surface of the cuvette is used to distribute the air supplied to the cuvette. Normally one would want to reserve that zone as a light entrance area. Fig. 6b shows a simplification of the previous option in that only one condenser/transfer wick is foreseen and therefore the flow pattern will be asymmetrical. Fig. 6c finally shows the option being apparently the simplest: Asymmetrical cross flow. Note that the top surface (lid) of the cuvette is available for undisturbed light entry.

A compilation of the advantages and the disadvantages of the water reclamation concept is given in Table 2.

ADVANTAGES	DISADVANTAGES
1. Rotating (1g) cuvettes need no water supply.	1. Each cuvette needs its own instrumentation.
2. Imbalance problem greatly relieved due to item 1.	2. Each cuvette needs its own Peltier cooler.
3. Neither the 1g- nor the micro-gravity cuvettes need a soil humidity sensor.	3. Each micro-gravity cuvette needs its own light fan.
4. Water no longer a consumable.	4. If a variation of the still water content during the growth period is desired, a small amount is needed.
5. Subsystem hardware weight reduced due to absence of Silica gel dryer.	5. Avoid consumption of Peltier elements and fan heater.

ADVANTAGES AND DISADVANTAGES OF CUVETTES WITH WATER RECLAMATION

Table 2: Advantages and disadvantages of cuvettes with water reclamation

3. ANALYSIS OF WATER RECLAMATION CONCEPT

Fig. 6 illustrates the loop schematic as far as thermal and electrical aspects are concerned. At first, a water balance shall be made. For the cuvette this balance reads:

$$\dot{G}_A \cdot (x_o - x_i) = \dot{G}_W \quad (1)$$

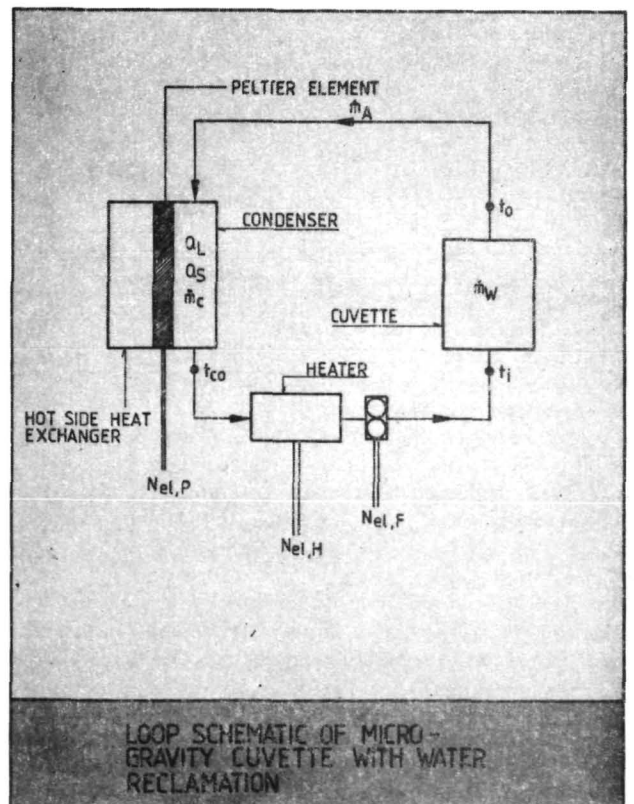

Fig. 6: Loop Schematic of microgravity cuvette with water reclamation

Similarly, the water balance for the condenser can be written as

$$\dot{G}_A \cdot (x_o - x_{Co}) = \dot{G}_C \quad (2)$$

since

$$\dot{G}_W = \dot{G}_C \quad (3)$$

and because one will normally prescribe x_o , one obtains from eq. (1), (2), (3) the following relation for x_{Co}

$$x_{Co} = x_o - \dot{G}_W / \dot{G}_A \quad (4)$$

From the relation between water content, x_{Co} , and air temperature, the air temperature at the condenser outlet, t_{Co} , can be determined. As can be seen from eq. (4), t_{Co} is a function of the cuvette air temperature and relative humidity and of the ratio \dot{G}_W / \dot{G}_A . Fig. 7 illustrates the variation of t_{Co} with \dot{G}_W / \dot{G}_A for a cuvette air temperature of 20 °C (68 °F) and a relative humidity of 80 % leading to $x_o = 12.15$ g/kg.

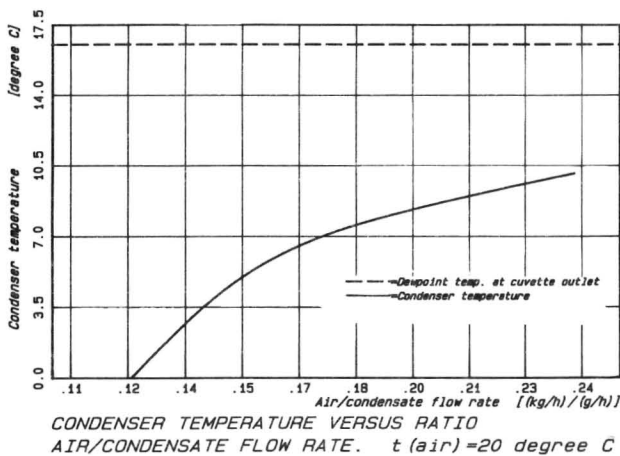

Fig. 7: Temperature at the condenser outlet as function of the air mass flow rate, \dot{G}_A , divided by the condensate flow rate, \dot{G}_W

Two limits are apparent in Fig. 7: Minimum \dot{G}_A / \dot{G}_W ratio is 0.127 (kg/h)/(g/h) because here the freezing point is reached. Obviously, one must not operate under that condition because no water transport is possible at that temperature. An infinite air flow rate is needed on the other hand if one wants to remove the evaporation rate \dot{G}_W under the condition that the air temperature at the condenser outlet is equal to that at the cuvette outlet, this characterises the second limit.

The next step is now to formulate a heat balance. Total condenser load is

$$\dot{Q}_C = \dot{Q}_s + \dot{Q}_l \quad (5)$$

Sensible load

$$\dot{Q}_s = c_p \cdot \dot{G}_A \cdot (t_o - t_{Co}) \quad (6)$$

Latent load

$$\dot{Q}_l = r \cdot \dot{G}_W \quad (7)$$

Combination of eq. (5) (6) (7) yields

$$\dot{Q}_C / \dot{G}_W = c_p \cdot \frac{\dot{G}_A}{\dot{G}_W} \cdot (t_o - t_{Co}) + r \quad (8)$$

For the heater power to heat the air re-entering the cuvette (see Fig. 6) one obtains after normalization with \dot{G}_W

$$\dot{Q}_H / \dot{G}_W = c_p \cdot \frac{\dot{G}_A}{\dot{G}_W} \cdot (t_i - t_{Co}) \quad (9)$$

Obviously, $t_o = t_i$.

Fig. 8 shows a numerical evaluation of eq. (8) and (9) as function of \dot{G}_A / \dot{G}_W for an air temperature of 20 °C and a relative humidity of 80 %.

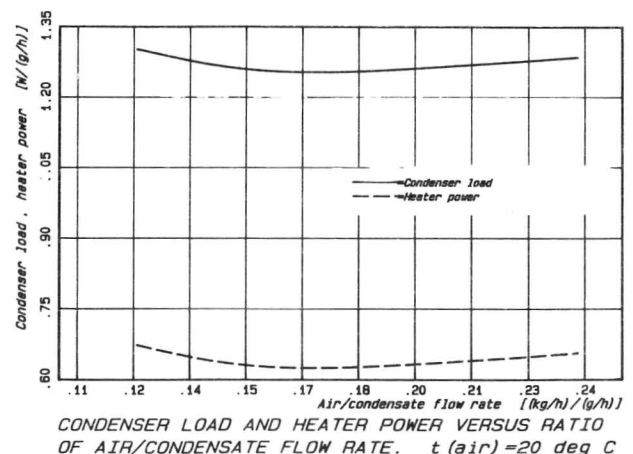

Fig. 8: Normalized condenser load \dot{Q}_C / \dot{G}_W and heater power \dot{Q}_H / \dot{G}_W as function of ratio \dot{G}_A / \dot{G}_W .

As can be seen from Fig. 8 an optimum value for \dot{G}_A / \dot{G}_W exists for which both the condenser load (and hence the load to be removed by the Peltier element) and the heater power attain

a minimum. This optimum is explainable by the fact that at the lower limit of Fig. 7 the temperature difference in eq. (8) and (9) (in fact the sensible heat load) reaches a maximum and the flow rate m_a a minimum while at the upper limit of Fig. 7 the opposite is true.

The optimum ratio corresponds to

$$(\dot{G}_A/\dot{G}_W)_{\text{opt}} = 0.19$$

and the corresponding temperature of the air at the condenser outlet is $t_{\text{Co}} = 8.1^\circ\text{C}$.

To get a feeling for the absolute power values it shall be assumed that $\dot{G}_W = 0.1$ g/hr. Then follows $\dot{Q}_C = 0.13$ W and $\dot{Q}_H = 0.06$ W for the optimum mass flow ratio $(\dot{G}_A/\dot{G}_W)_{\text{opt}}$.

Finally, the required electrical power to operate the Peltier element shall be estimated. As will be recalled, a measure of the quality and the actual operation condition of a Peltier element is the Coefficient Of Performance (COP) which is defined as

$$\text{COP} = \frac{\text{heat absorbed by cold side}}{\text{electrical input power}} \quad (10)$$

The heat to be removed on the hot side of the element is

$$\dot{Q}_{P,H} = N_{\text{el},P} + \dot{Q}_C \quad (11)$$

Combination of eq. (10) (11) results in

$$\dot{Q}_{P,H}/N_{\text{el},P} = 1 + \text{COP} \quad (12)$$

Typical COP-values are in the neighbourhood of 0.3. This then leads for the evaporation ratio used in the example, namely $\dot{G}_W = 0.1$ g/hr to $N_{\text{el},P} = 0.43$ W and to $\dot{Q}_{P,H} = 0.56$ W.

By using a regenerative heat exchanger a portion of the hot side heat load of the Peltier element can be used to reheat the air returning to the cuvette and therefore the heater power $N_{\text{el},H}$ (0.06 W in the example) can be saved.

Power for the mini-fan is according to current experience appr. 0.2 W. So, assuming zero heat leaks and heat regeneration the total required electrical power would be $0.43 + 0.2 = 0.63$ W for an evaporation rate of 0.1 g/hr.

Presently 18 stationary (microgravity) and 6 rotating (1 g) cuvettes are specified in the BF requirements. Neglecting the fact that the heater needed in the 1 g-cuvettes very probably will have a lower dissipation than the fans in the micro-gravity cuvettes one will end up with a total electrical power consumption of appr. $N_{\text{el},\text{total}} = 24$ W assuming zero heat leaks.

Compared with the budget allocated to the BF of 160 W this is already a significant although not unacceptable amount.

So the practical design must be carefully optimized to minimize heat leaks in order to come at least close to the theoretical performance of $N_{\text{el},P+F}/\dot{G}_W \cong 6.3$ W/(g/hr).

4. DESIGN OF A WATER RECLAMATION MODULE

In order to demonstrate the feasibility of the concept of cuvettes with internal water reclamation, a Water Reclamation Module (WRM) has been conceived, designed, manufactured and tested.

Since it was felt that the concept would be more difficult to verify for the microgravity cuvettes the design of the WRM was limited to that part.

As will be clear from the concept description, the critical element in a microgravity cuvette is the Condenser/Wick Assembly (CWA) which interfaces with the Peltier element.

The major requirements the CWA has to meet are as follows:

1. Large specific surface area to minimize temperature difference between Peltier element cold side and condenser surface with which the air comes into contact.
2. Wick material must have a good thermal conductivity for the reason mentioned in item 1.
3. Wick material must have a good capillary action.
4. Wick design must be self-priming, i.e. it must show capillary action even if it is initially completely dry.

Usual cotton wicks, for example, as used in commercial oil lamps have been considered in the beginning since they exhibit good capillary force but there are 2 drawbacks:

- (a) They contain a small amount of cotton oil prohibiting water adsorption and
- (b) thermal conductivity of cotton is very poor. The next thought was to use a wick made out of a grid of stainless steel. Two samples are shown in Fig. 9.

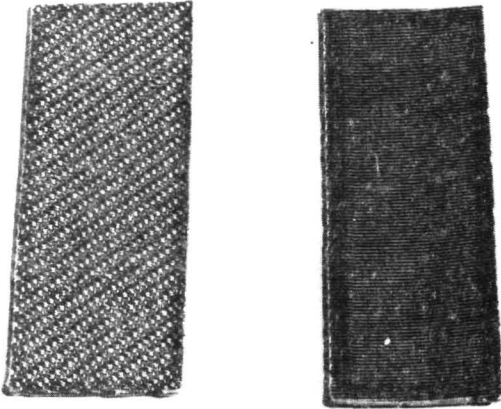

Fig. 9: Grid samples consisting of stainless steel wires. Edges are seamed by electron beam welding, length 70 mm, width 10 mm

Although the thermal conductivity was much better than that of a cotton wick, the self-priming requirement could only be met by adding a chemical wetting fluid to the water. Since we were not sure if that fluid would stay during a mission time of several months in the soil without degradation (and thus creating contaminants for the plant samples) also that wick material was rejected.

The following step was to think about a composite wick design, namely to use one material having a good thermal conductivity in order to fulfill requirements 1 and 2 and use a second material providing the capillary force and being self-priming to meet requirements no. 3 and 4. Therefore various copper nets have been evaluated as condenser element, 2 samples are shown in Fig. 10.



Fig. 10: Samples of copper grid material used as condenser material

As a wick material a commercially available capillary mat was used and the resulting design concept is shown in Fig. 11.

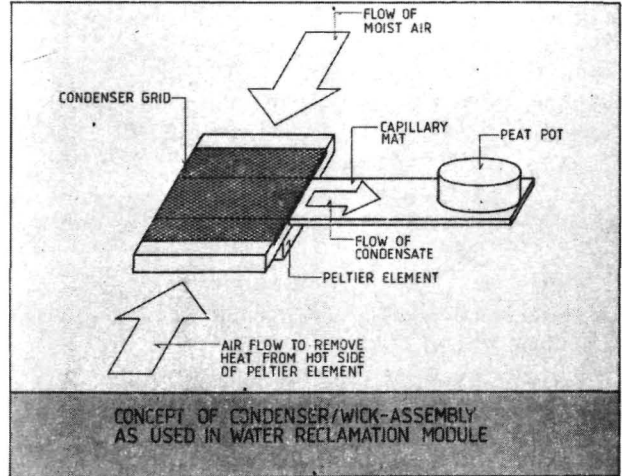

Fig. 11: Design concept as used for water reclamation module

The actual design is then illustrated in greater detail in Fig. 12.

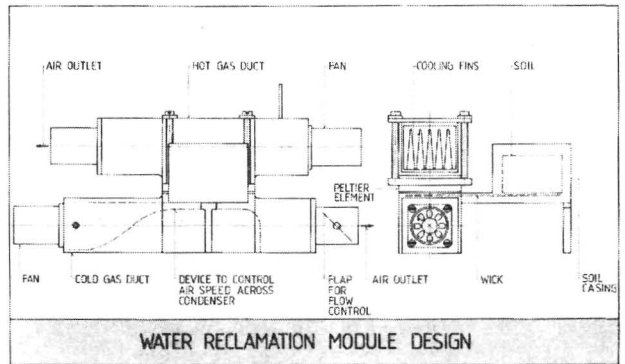

Fig. 12: Water reclamation module design

As can be seen from Fig. 12 ambient air is sucked by means of a small fan through the cold gas duct and is cooled/dried at the condenser. The water absorbed by the wick assembly is transported to the soil which is contained in a casing in order to prevent evaporation.

The waste heat is removed by air drawn by another fan through the hot gas duct.

5. TEST HARDWARE

The actual hardware used for the tests is shown in Fig. 13 which depicts the WRM with thermal insulation in order to minimize heat exchange with the environment and from the hot gas to the cold gas duct. Insulation consisted of a foam material (ROHACELL) and a layer of goldized KAPTON.

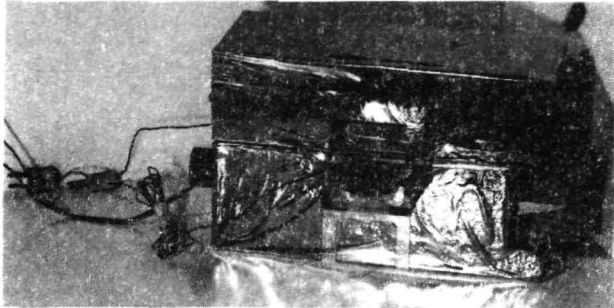

Fig. 13: Assembled WRM with insulation

Fig. 14 gives a better view how the thermal interaction between the 2 gas ducts other than via the cooling fans was tried to minimize.

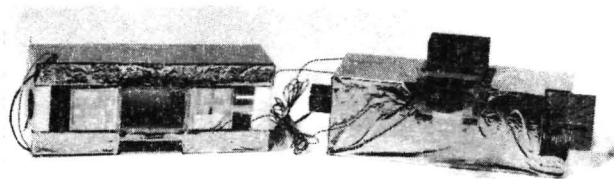

Fig. 14: Thermal insulation of cold and hot side air ducts

The disassembled WRM is shown in Fig. 15.

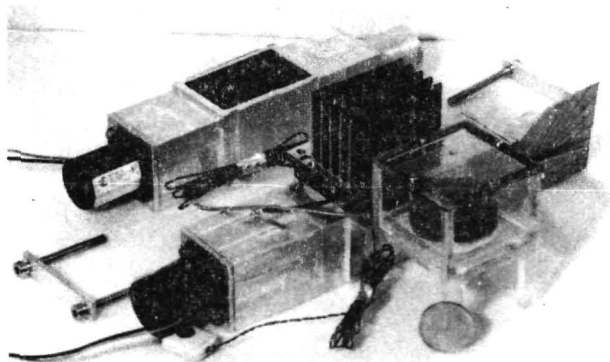

Fig. 15: WRM, disassembled

Details of the design of the wick assembly, the cooling fins and the soil housing can be detected from Fig. 16.

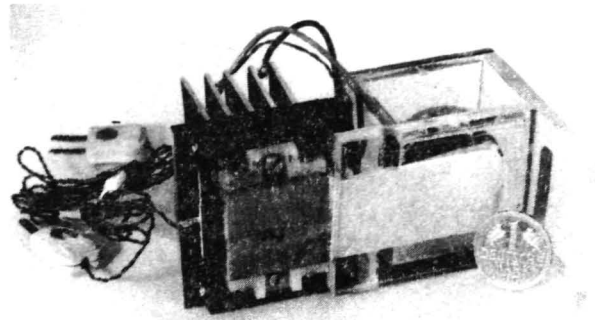

Fig. 16: Detail of wick assembly and its routing into the soil housing. Also shown are the cooling fins

6. TEST SET-UP, INSTRUMENTATION AND CONDITIONS

The test set-up is shown in Fig. 17. As can be seen from the picture, the WRM was placed on an electronic scale in order to determine the weight difference in a certain time period due to the condensate accumulated in the soil.

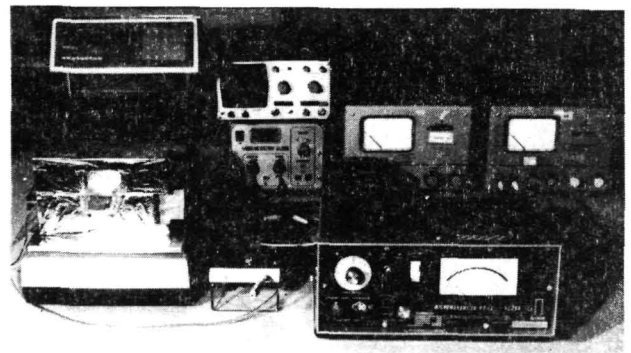

Fig. 17: Test arrangement used for the WRM

Three power supplies were used to provide regulated DC power to the Peltier element, the cold side fan and the hot side fan. Rather than using flow meters, the cold and hot side mass flow rate was determined by means of a delta pressure reading with a micromanometer. The relation between delta pressure and volume flow of the two ducts was determined prior by means of a volume flow meter and the same micromanometer. Thermocouples have been placed at the following locations:

1. Air, ambient
2. Air, outlet, fin
3. Air, outlet, condenser
4. Condenser grid
5. Peltier element, cold side
6. Peltier element, hot side

Tests were initially performed in a clean room in order to have fairly constant ambient conditions. But due to the comparatively dry air no condensation could be observed. Therefore another room was selected the air humidity of which was artificially increased to approx. 50 % with a rather primitive humidifier. However, this value is still far below the operation range of 80 - 90 % foreseen for the BF.

7. TEST RESULTS AND DISCUSSION

Since the detailed test data reduction is described in (2) and (3), only the test results shall be discussed below.

Fig. 18 shows the condensation rate as function of the cold side mass flow rate.

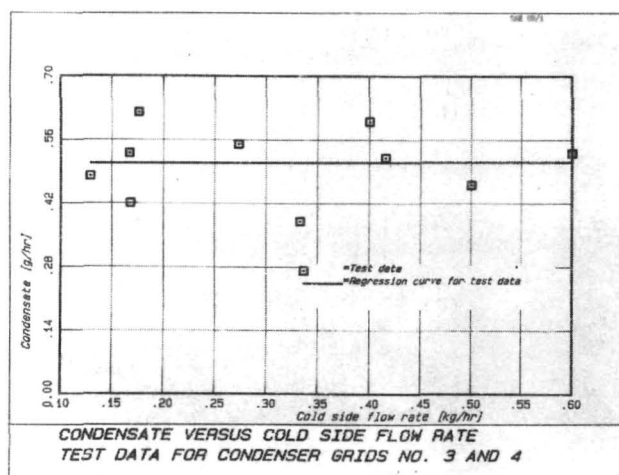

Fig. 18: Condensate versus cold side flow rate. Test data for condenser grid no. 3 and 4.

Despite of the considerable scatter it is apparent that the device functions as expected.

The power of the Peltier element was $N_{el,P} = 6$ W, that for the fan $N_{el,F} = 0.36$ W, the measured condensation rate $\dot{G}_W = 0.51 \pm 0.08$ g/hr, hence the measured performance $N_{el,P+F}/\dot{G}_W = 12.5$ W/(g/hr).

If one compares that value with the theoretical performance of 6.3 W/(g/hr) as predicted in section 3 one must conclude that the design has to be refined in order to further reduce heat leaks.

Fig. 19 illustrates the measured condenser temperatures and again no significant variation with the cold side mass flow can be observed.

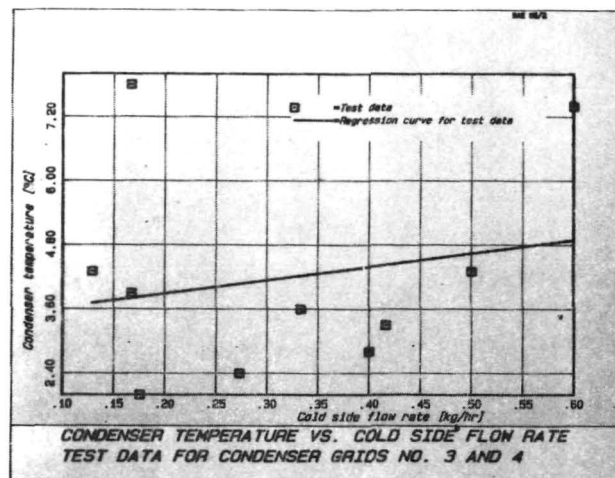

Fig. 19: Condenser temperature versus cold side flow rate. Test data for condenser grid no. 3 and 4.

Fig. 20 depicts the variation of the temperature difference between the condenser grid and the the cold side of the Peltier element with the cold side mass flow rate.

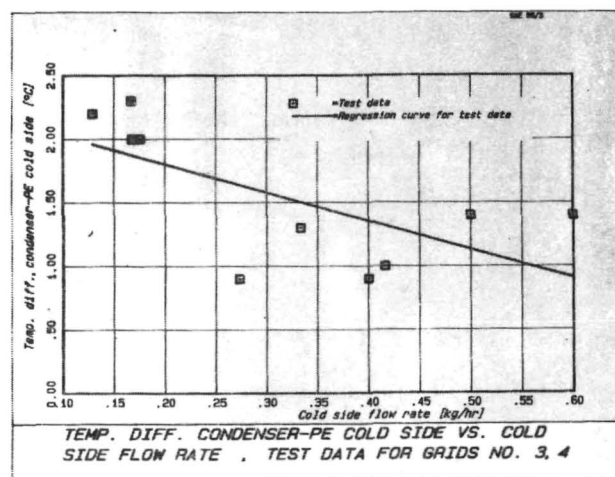

Fig. 20: Temperature difference between Peltier element cold side and condenser grid versus cold side mass flow rate. Test data for condenser grid no. 3 and 4.

As can be seen from the figure, that difference is in the order of 1.5 °C (2.7 °F) and allows therefore the conclusion that the thermal contact between the cold side of the Peltier element and the condenser grid is quite good.

Fig. 21 shows the difference between the air at the condenser outlet and the condenser grid.

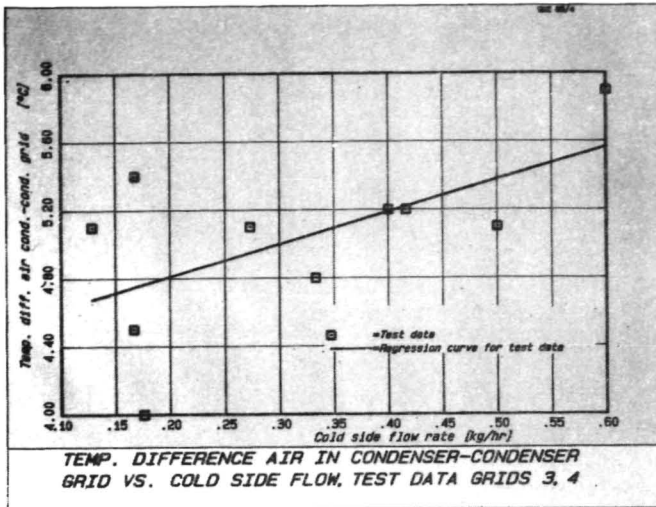

Fig. 21: Temperature difference between the air at the condenser outlet and the condenser grid versus cold side mass flow rate. Test data for condenser grid no. 3 and 4.

Appr. 5 °C (9 °F) are observed, a fact which clearly indicates that in a future design the transfer area should be significantly increased in order to reduce the temperature difference.

Finally, Fig. 22 illustrates that the temperature difference between the Peltier element hot side and the outlet air is appr. 7.5 °C (13.5 °F). Clearly, design improvements are necessary also in this area.

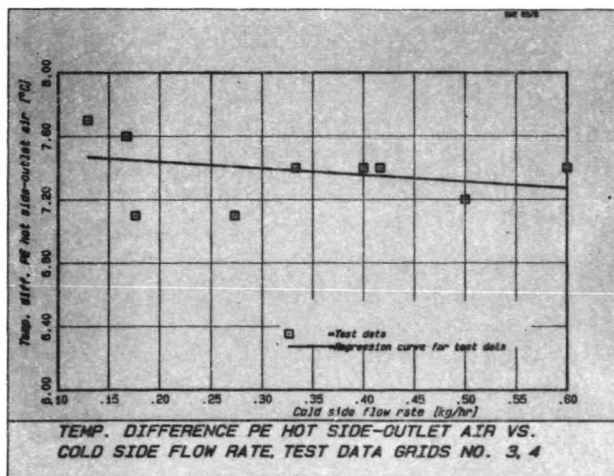

Fig. 22: Temperature difference between hot side of Peltier element and outlet air versus cold side mass flow rate. Test data valid for condenser grid no. 3 and 4.

8. SUMMARY AND CONCLUSIONS

- o A concept for the Life Support Subsystem of the BOTANY FACILITY is described which for the task of the humidity control of the atmosphere is based on water reclamation. Such reclamation is obtained by using a Peltier element and a condenser/wick assembly by which elements the water removed from the air is routed back into the soil supporting the plant samples.
- o This reclamation concept is applicable to cuvettes (= plant growth chambers) flown in micro-gravity and 1 g environment but it are the former which appear technologically more sophisticated.
- o By simple analyses an estimate of the specific power consumption (Watt/g/hr condensate) is provided in order to see if the resulting power consumption is compatible with the power budget allocated to the BOTANY FACILITY.
- o In order to prove the feasibility of the concept, a pre-prototype of a water reclamation module has been designed, manufactured and tested.
- o The test results confirm the viability of the concept. They show on the other hand that a very careful thermal design of the Peltier element/waste heat rejection/condenser/wick assembly is required to minimize heat leaks and to come at least close to the theoretical value of the specific power consumption in terms of Watt per g/hr condensate.

9. NOMENCLATURE

ASACC	:	Atmosphere Storage And Composition Control
BF	:	Botany Facility
COP	:	Coefficient of performance
G	:	Mass flow rate in kg/hr (air) or g/hr (water)
LSS	:	Life Support Subsystem
N	:	Electrical power consumption (W)
Q	:	Heat load (W)
VASAH	:	Ventilation And Soil/Air Humidification
WRM	:	Water Reclamation Module
c_p	:	Specific heat at constant pressure
r	:	heat of evaporation
t	:	Temperature in degree C (degree F)
x	:	Air water content in g water per kg dry air

10. SUBSCRIPTS

A : Air
 C : Condenser
 F : Fan
 H : Heater
 P : Peltier element
 W : Water
 i : inlet
 l : latent
 o : outlet
 s : sensible

11. REFERENCES

1. Dr. H. Löser
 Proposed Life Support System for the Botany Facility - A Payload of the European Retrievable Carrier to be flown with the Space Shuttle
 Paper 840946, presented at the 14th Intersociety Conference on Environmental Systems, San Diego, California, July 16-19, 1984
2. Dr. H. Löser
 First test results obtained with a water reclamation module
 TN-RT 554-020/84
3. S. Szabadi
 Versuch, die interne Wasserversorgung der Küvetten für die Botany Facility mit Hilfe eines Peltierelements zu lösen.
 TN-RT 554-051/84

12. ACKNOWLEDGEMENT

The work of Mr. S. Szabadi who designed, manufactured and tested the WRM is gratefully acknowledged.