

NASA TM-87695

NASA Technical Memorandum 87695

NASA-TM-87695 19860012833

AIRPORT-NOISE LEVELS AND ANNOYANCE MODEL
USER'S GUIDE

FOR REFERENCE

NOT TO BE TAKEN FROM THIS ROOM

Richard DeLoach
James Donaldson
Margaret Johnson

JANUARY 1986

LIBRARY COPY

MAR 26 1986

LANGLEY RESEARCH CENTER
LIBRARY, NASA
HAMPTON, VIRGINIA

NASA

National Aeronautics and
Space Administration

Langley Research Center
Hampton, Virginia 23665



NF01267

CONTENTS

1.0 INTRODUCTION1-1

2.0 PURPOSE OF THE MODEL2-1

3.0 BASELINE SUBSYSTEM3-1

 3.1 SUBSYSTEM ARCHITECTURE3-2

 3.1.1 Integrated Noise Model3-5

 3.1.2 Contour Processor3-6

 3.1.3 Site II System3-7

 3.1.4 Report Generator3-8

 3.2 SUBSYSTEM USAGE3-9

 3.2.1 File Creation and Retrieval3-10

 3.2.1.1 Program Modules3-10

 3.2.1.2 Demographic Data3-13

 3.2.1.3 Airport Description Data Deck3-13

 3.2.1.4 Airport Auxiliary File3-14

 3.2.2 File Naming Conventions3-17

 3.2.3 Preliminary Processing3-19

 3.2.3.1 Tape Initialization3-19

 3.2.3.2 Verify3-21

 3.2.4 CYBER Control Language3-22

 3.2.5 Restrictions3-25

 3.2.6 Sample Subsystem Results3-26

 3.2.7 Case Runner's Check List3-38

4.0	<u>NOISE REDUCTION SIMULATION SUBSYSTEM</u>	4-1
4.1	SUBSYSTEM ARCHITECTURE	4-3
4.1.1	<u>CYBER Control Language Generator</u>	4-6
4.1.2	<u>Integrated Noise Model Data Base Modifier</u>	4-7
4.1.3	<u>Plot/Report Generator</u>	4-8
4.2	SUBSYSTEM USAGE	4-9
4.2.1	<u>File Modification and Retrieval</u>	4-10
4.2.1.1	Program Modules	4-10
4.2.1.2	Airport Auxiliary File	4-13
4.2.2	<u>File Naming Conventions</u>	4-15
4.2.3	<u>CYBER Control Language</u>	4-17
4.2.4	<u>Sample Subsystem Results</u>	4-19
4.2.5	<u>Case Runner's Check List</u>	4-22
5.0	<u>TRACK ANALYSIS SUBSYSTEM</u>	5-1
5.1	SUBSYSTEM ARCHITECTURE	5-3
5.1.1	<u>SITE II Input Generator</u>	5-6
5.1.2	<u>SITE II Demographics System</u>	5-7
5.1.3	<u>Track Converter</u>	5-8
5.1.4	<u>Track Plot Generator</u>	5-9
5.1.5	<u>Track Population Report Generator</u>	5-10
5.2	SUBSYSTEM USAGE	5-11
5.2.1	<u>File Creation and Retrieval</u>	5-12
5.2.1.1	Program Modules	5-12
5.2.1.2	Airport Description Data Deck	5-14
5.2.1.3	Airport Auxiliary File	5-15

5.2.2	<u>File Naming Conventions</u>	5-17
5.2.3	<u>CYBER Control Language</u>	5-20
5.2.4	<u>Sample Subsystem Results</u>	5-22
5.2.5	<u>Case Runner's Check List</u>	5-25
6.0	<u>APPENDICES</u>	A-1
6.1	APPENDIX A - SITE FILE PROCEDURES	A-1
6.2	APPENDIX B - ALAMO MULTI-FILE PROCEDURE FILE	B-1
6.3	APPENDIX C - F. A. A. IDENTIFIERS	C-1
7.0	<u>FIGURES</u>	
7.1	Figure 1. Block diagram of Baseline System	3-3
7.2	Figure 2. Submit file for tape initialization	3-23
7.3	Figure 3. Submit file for Baseline verify job	3-23
7.4	Figure 4. Submit file for primary Baseline job	3-24
7.5	Figure 5. Baseline LDN footprint for major midwestern airport	3-27
7.6	Figure 6. Report resulting from execution of baseline subsystem	3-28
7.7	Figure 7. Case runner's checklist for Baseline subsystem	3-39
7.8	Figure 8. Block diagram of Noise Reduction Simulation Subsystem	4-4
7.9	Figure 9. Submit file for Noise Reduction Simulation CCL generation job	4-18
7.10	Figure 10. Submit file for Noise Reduction Simulation Plot/Report job	4-18
7.11	Figure 11. Tabulated results of source noise reduction	4-20
7.12	Figure 12. Noise impact of source noise reduction	4-21
7.13	Figure 13. Case runner's checklist for noise reduction simulation	4-23
7.14	Figure 14. Block diagram of track analysis subsystem	5-4

7.15	Figure 15.	Submit file for track analysis job.....	5-21
7.16	Figure 16.	Plot resulting from track analysis subsystem execution.....	5-23
7.17	Figure 17.	Report resulting from track analysis subsystem execution.....	5-24
7.18	Figure 18.	Case runner's checklist for case analysis:..	5-26
7.19	Figure A1.	Submit file for SITE II file retrieval.....	A-3
7.20	Figure A2.	SITE II multi-procedure file.....	A-4
7.21	Figure B1.	ALAMO system multi-procedure file.....	B-3

8.0 TABLES

8.1	Table I.	Baseline Module Specifications.....	3-4
8.2	Table II.	Baseline Modules.....	3-12
8.3	Table III.	Airport auxiliary file format Baseline Subsystem.....	3-16
8.4	Table IV.	Baseline file naming conventions.....	3-18
8.5	Table V.	Noise reduction simulation module specifications.....	4-5
8.6	Table VI.	Noise reduction simulation modules.....	4-12
8.7	Table VII.	Airport auxiliary file format. Noise reduction simulation subsystem.....	4-14
8.8	Table VIII.	Noise reduction simulation file naming conventions.....	4-16
8.9	Table IX.	Track analysis module specifications.....	5-5
8.10	Table X.	Track analysis modules.....	5-13
8.11	Table XI.	Airport auxiliary file format. Track analysis subsystem.....	5-16
8.12	Table XII.	Track analysis naming conventions.....	5-18
8.13	Table AI.	SITE II state codes and abbreviations.....	A-3

INTRODUCTION

1.0 INTRODUCTION

The purpose of this document is to provide a guide for the use of the Airport-noise Levels and Annoyance Model (ALAMO) at the Langley Research Center computer complex. This document is divided into 5 primary sections, the Introduction, the Purpose of the Model, and an in-depth description of the following subsystems: Baseline, Noise Reduction Simulation and Track Analysis. For each subsystem, the user is provided with a description of architecture, an explanation of subsystem use, sample results, and a case runner's check list. It is assumed that the user is familiar with the operations at the Langley Research Center (LaRC) computer complex, the Network Operating System (NOS 1.4) and CYBER Control Language. Incorporated within the ALAMO model is a census database management system called SITE II, licensed from CACI, Inc. SITE II is a registered trademark of CACI, Inc.

NOTES AND COMMENTS

PURPOSE OF THE MODEL

2.0 PURPOSE OF THE MODEL

The Airport-noise Levels and Annoyance Model (ALAMO) is a computer program which can model the noise environment in an airport community over a 24-hour period. The model contains data from the 1980 United States census. This data is used to determine the number of people exposed to airport noise as a function of the noise level for any airport community in the United States. Noise levels in the community are determined by means of the Integrated Noise Model (INM), a noise "footprint" model developed by the FAA to calculate the contours of constant noise exposure around an airport which corresponds to a particular operating scenario defined as input to the model.

The noise impact of a given operating scenario is computed by means of the Fractional Impact Method, in which the total number of people exposed to a given level of noise is multiplied by a weighting factor which depends on the noise level, with higher noise levels corresponding to higher values of the weighting function. The number of people exposed to airport noise, weighted in this way by noise level, is called the Level Weighted Population, and serves as a measure of airport community noise impact. This quantity accounts explicitly for the distributions of both noise level and population in the airport community, as well as human subjective response, through the weighting function.

The ALAMO model performs the Fractional Impact calculations for the airport community as a whole, and for each of eight "neighborhoods" within the community, defined by overlaying an imaginary octant compass rose over the airport. Thus, the noise impact is also computed as a function of direction from the airport. In addition to the noise impact calculations which are performed, the model generates reports of the total number of people under the noise "footprint" of the airport as a function of noise level, and certain socioeconomic parameters also as a function of noise level. It is possible to determine average home values, percentage of owners/renters, average family income, percent white-collar/blue-collar employment, and related parameters all as a function of noise level. These data are available for the community as a whole and for each of the eight "neighborhoods" defined by the octant compass rose described above.

BASELINE SUBSYSTEM

3.0 BASELINE SUBSYSTEM

The Airport-noise Levels and Annoyance Model (ALAMO) is a computerized system capable of overlaying aircraft noise footprints on the population distribution of a designated airport; the correlation of noise exposure levels with the impacted population provides a means of evaluating the effect of airport noise on the surrounding community. ALAMO, in the baseline mode, analyzes a user-provided description of airport configuration and operations that most closely represents an existing scenario. The results of an ALAMO baseline execution are expressed in both plot and report form.

The plot produced by ALAMO represents the contours, or noise footprints, found through an analysis of the described operations; an octant line compass rose is superimposed over the contour plots to afford a visual representation, on an octant-by-octant basis, of the contour distribution in the airport community. The second product of an ALAMO baseline run is a series of 10 reports based on a demographic analysis of the contours generated. The first 8 reports represent the correlation of demographic variables with noise exposure levels, on an octant-by-octant basis. The ninth report is a demographic noise exposure report for all octants. The final report is an airport community noise impact summary report.

Subsystem Architecture

3.1 Subsystem Architecture

An ALAMO baseline run utilizes the following four major modules, executed in order of presentation: the Integrated Noise Model, the Contour Processor, the SITE II Demographics Program, and the Report Generator. A block diagram of this subsystem is illustrated by Figure 1. Module input/output specifications can be found in Table I, where both file descriptions and file names are denoted. During ALAMO baseline execution, certain default file names are overridden by names compatible with ALAMO file identification conventions. Such paired file names enclosed in parentheses, are indicated in Table I; the default file name is specified first, and the overriding file name follows.

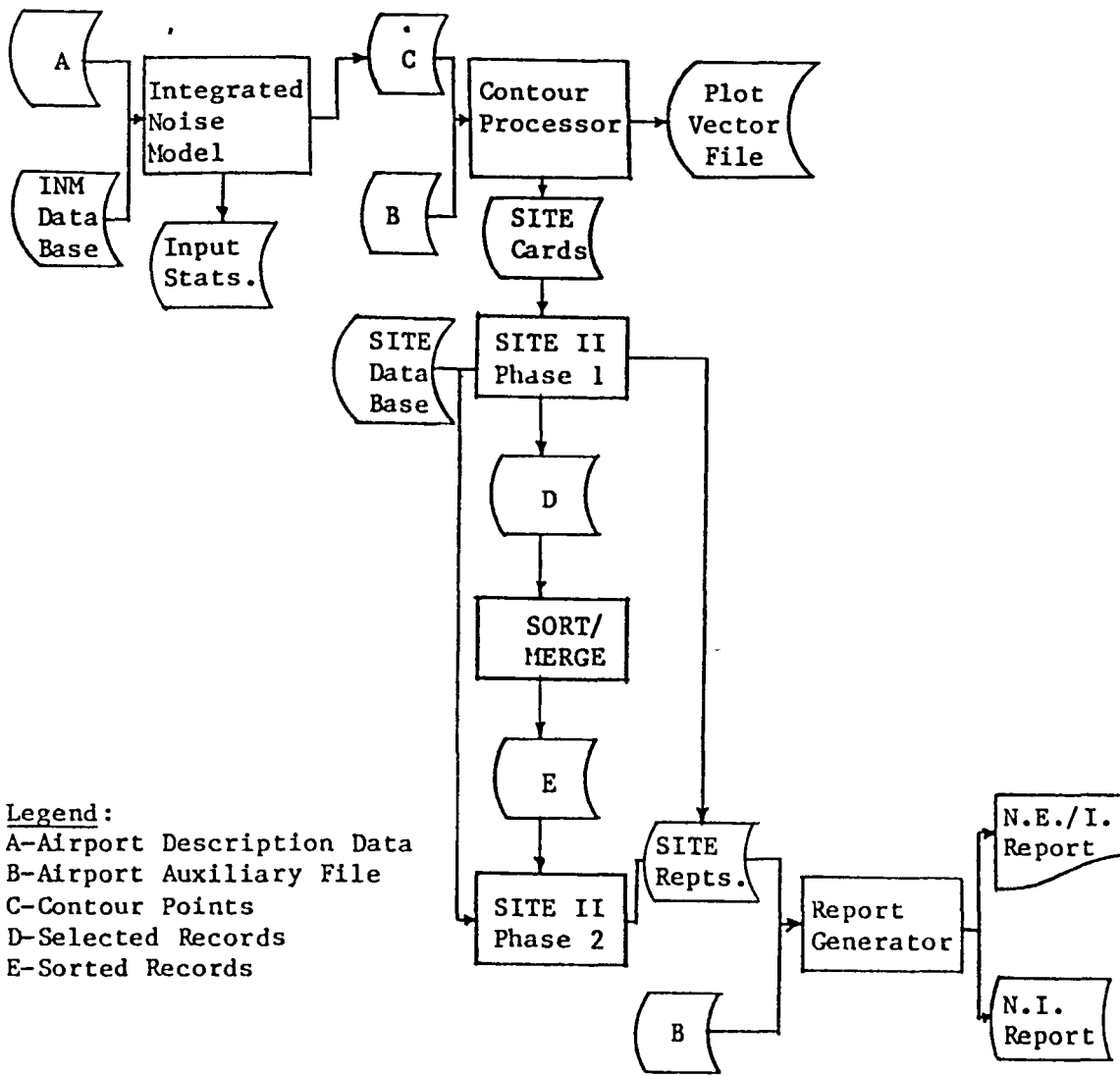

Figure 1.-Block diagram of Baseline subsystem

TABLE I.-BASELINE MODULE SPECIFICATIONS

INTEGRATED NOISE MODEL

NAME : CONTORA
FUNCTION : Contour Generation
INPUT : Airport Description Data Deck (TAPE5/XXX001)
INM Data Base (TAPE7)
OUTPUT : Airport Statistics (TAPE6/XXX002)
Contour Points (TAPE2/XXX003)
SCRATCH : TAPE3, TAPE8, TAPE9

CONTOUR PROCESSOR

NAME : AUPHSIA
FUNCTION : Contour Processor
Airport Auxiliary File (TAPE2/XXX)
Contour Points (TAPE5/XXX003)
OUTPUT : SITE II Input Cards (TAPE1/XXX004)
Plot Vector File (XXX005)
SCRATCH : TAPE4

SITE II DEMOGRAPHICS MODULES

Phase 1

NAME : PH1A
FUNCTION : Input Processor/Record Selector
INPUT : SITE II Input Cards (TAPE5/XXX004)
SITE II Data Base (TAPE21/NSF1, TAPE22/NSF2,
TAPE23/NSF3)
OUTPUT : Input Reflection (TAPE6/XXX006)
Selected Records (TAPE1)
SCRATCH : TAPE11

Phase 2

NAME : PH2A
FUNCTION : SITE II Report Writer
INPUT : Sorted Records (TAPE2)
SITE II Data Base (TAPE31/MNF1, TAPE32/MNF2,
TAPE33/MNF3)
OUTPUT : SITE II Reports (TAPE6/XXX006)
SCRATCH : TAPE2, TAPE3, TAPE4, TAPE8

REPORT GENERATOR

NAME : AUREPTA
FUNCTION : ALAMO Report Generator
INPUT : SITE II Reports (TAPE5/XXX007)
Airport Auxiliary File (TAPE1/XXX)
OUTPUT : 10-Page Report (TAPE6)
Noise Impact Summary Report (TAPE2/XXX008)
SCRATCH : None

3.1.1 Integrated Noise Model

Integrated Noise Model.- THE INTEGRATED NOISE MODEL (INM), a product of the Federal Aviation Administration, is designed to compute noise exposure values due to aircraft operations around airports. Noise contours are defined by a sequence of points, exhibiting closure, that are subject to levels of equal noise exposure. Input required by the INM is twofold; the first input required is the Airport Description Data Deck, containing descriptions of airport characteristics (altitude, average daily temperature, runway and track descriptions), descriptions of airport operations (aircraft selected, profile descriptions, aircraft mix information), and the specific values of contours requested. The second source of input to the INM is the INM database, a standard database of aircraft noise and performance, representing commercial, general aviation, and military aircraft. INM output, as utilized by ALAMO, is twofold. The first file produced is a listable report reflecting a statistical breakdown of the airport scenario, followed by a printout of contour coordinates and area impacted. A second file contains the noise contour coordinates in a format compatible for use by the ensuing module, the Contour Processor.

3.1.2 Contour Processor

Contour Processor.- The Contour Processor, the second ALAMO module to be executed, redescribes the INM contour data in terms of a series of polygons; these polygons are described in an input format compatible with the SITE II Demographics Program (SITE II), thus providing a link between the INM contours and the SITE II demographics data. The description of contours in polygonal form is accomplished through the superimposition of an octant line compass rose over the original contours; polygons are defined for each octant by the intersection of the octant line and the contour line. The input files required by the Contour Processor are the INM contour points, and the Airport Auxiliary File. The auxiliary file contains necessary information such as airport latitude and longitude, axis translation values, an axis length indicator, airport name, and airport address. Output generated by the Contour Processor consists of the polygonal contour descriptions, in SITE II specific format, and plot vector file containing a representation of the contours found.

3.1.3 Site II System

Site II System.- The third phase of the ALAMO baseline subsystem is the execution of the SITE II System, a commercial demographic retrieval system licensed from CACI, Inc. This program queries a census database and produces a demographic profile report for a user-designated area. This database contains the population and household counts that were obtained from the 1980 census, updated to 1981; additional demographic and housing data was obtained from the 1970 census. Within the ALAMO baseline subsystem, SITE II uses as input the polygonal contour descriptions, as produced by the Contour Processor; essentially, each polygon is processed by SITE II, and a corresponding demographic profile report is produced. The SITE II Demographics Program consists of 2 separate modules; the first module processes the polygons described, and extracts appropriate records from the SITE II database; the selected records are then processed by the SORT/MERGE utility, according to user-provided directives. The sorted records provide input, along with additional database information, for the second phase of SITE II, which aggregates the census data and generates reports. The final product generated by SITE II is a demographic profile report for each polygon described by the Contour Processor.

3.1.4 Report Generator

Report Generator.- The final module that completes the ALAMO baseline subsystem is the Report Generator, a processor that consolidates the demographic variables from the SITE II demographic profile reports, and in turn produces a series of 10 noise exposure reports, done on an octant-by-octant basis. The ninth report is a demographic noise exposure report for all octants. The tenth report is an airport community noise impact summary report. Input to the Report Generator consists of the 2 following files: the SITE II demographic profile reports, and the Airport Auxiliary File. The auxiliary file is a multipurpose file containing information shared by several ALAMO modules. Information it contains, pertinent to the Report Generator, is a designated year for population updates, an optional growth rate for population updating, airport name, and airport address. Output created by the Report Generator consists of 2 files, the first containing the full 10-page ALAMO report, and the second containing only the noise impact summary report. The abbreviated file is used in conjunction with other ALAMO subsystems.

Subsystem Usage

3.2 Subsystem Usage

To accomplish an ALAMO baseline run, the user must step through the three following basic procedures:

1. File creation and retrieval
2. Preliminary processing
3. Submission of the appropriate Cyber Control Language (CCL) to drive ALAMO baseline execution.

Descriptions of these procedures follow; additionally, file-naming conventions, and baseline subsystem restrictions are addressed.

3.2.1 File Creation and Retrieval

File creation and retrieval.- Four categories of files must be retrieved or created for an ALAMO baseline subsystem run. Those categories included are:

1. Program modules and execution procedures
2. SITE II demographic data
3. The Airport Description Data Deck
4. The Airport Auxiliary File

Files in categories 1 and 2 reside on tape, and retrieval procedures are described below. The user must provide the Airport Description Data Deck and the Airport Auxiliary File.

3.2.1.1 Program Modules

Program modules: ALAMO program modules, the INM database, and an ALAMO multi-procedure file, are stored on a single magnetic tape, and must be brought online prior to ALAMO baseline execution. Following retrieval from tape, the files must be stored on the appropriate cluster, under specific file identifiers, as illustrated in TABLE II. All files listed in TABLE II are required for the execution of the ALAMO

baseline subsystem. Each file can be accessed individually, by name, utilizing the following 2 statements in a submit file:

```
LABEL(TAPE1,VSN=NN0120,PO=R,FA=Y,SI=ALAMO,FI=filename)  
COPYEI(TAPE1,filename)
```

All submit files should be stored on the WFS cluster and all files intended for the WFS cluster must be defined prior to the COPYEI statement, to ensure a successful file creation. Likewise, the SAVE command must be issued, following the COPYEI statement, for all files designated for the CPFS cluster.

TABLE II.-BASELINE MODULES

<u>FILE NAME</u>	<u>CLUSTER</u>	<u>FUNCTION</u>
AUPHS1A	CPFS	Contour Processor
AUREPTA	CPFS	Report Generator
A2	CPFS	ALAMO Procedure File
CONTORA	WFS	INM Contour Program
DATABIN	WFS	INM Data Base
PH1A	CPFS	SITE II-Phase 1
PH2A	CPFS	SITE II-Phase 2
SET	CPFS	SITE II Procedure File
SORTFL	CPFS	SORT/MERGE Directives

3.2.1.2 Demographic Data

Demographic data: Demographic data required for an ALAMO baseline run resides on files extracted from the SITE II database, a large database stored on tape. A description of file retrieval, including copies of the required procedures, and the submit file, is found in Appendix A, SITE II FILE PROCEDURES. SITE II files must be created prior to the submission of an ALAMO baseline run. The user should note that the resultant files must be created on the WFS cluster; after a successful retrieval, files will exist under the names of MNF1, MNF2, MNF3, NSF1, NSF2, and NSF3.

3.2.1.3 Airport Description Data Deck

Airport description data deck: The Airport Description Data Deck is the primary file that the user must provide for an ALAMO baseline run. This file, required by the Integrated Noise Model Contour Program, contains such information as airport description data, aircraft selection information, profile data, and operations information. The user is referred to the Integrated Noise Model Version 2 User's Guide for a detailed description of input file requirements. In addition, this file must be developed according to ALAMO system constraints, as

defined in the "Restrictions" section to follow. The file must be stored on the CPFS cluster, with a designated file name of XXX001. Here the character string XXX represents the unique Federal Aviation Administration (F.A.A.) identifier for the airport under study. An explanation of the use of this F.A.A. identifier can be found in the section titled "File-naming Conventions", to follow.

3.2.1.4 Airport Auxiliary File

Airport auxiliary file: The Airport Auxiliary File is a file, created by the user, containing airport-related information required by the baseline subsystem but not found in the Airport Description Data Deck. This file is shared by a number of modules in the ALAMO system. The file consists of 11 records; records 1 through 6 are not used in an ALAMO baseline run, and thus can be left blank; however, the records must exist for formatting purposes. Records 7 through 11 contain information required for an ALAMO baseline run; the file should be structured with the information and designated formatting as shown in Table III. Card 7 contains airport latitude and longitude, and optional displacement values; this information is required by the Contour Processor in order to create input for the SITE II Demographics Program. The displacement values, expressed in miles, are selected if the user does not know the coordinates of the airport under study, but

does not know the distance of the airport from a known coordinate pair. The user is referred to the SITE II User's Manual, Appendix III for further details regarding the displacement option. Card 8 contains the X and Y translation values, expressed in feet; these values are used to translate axes for the noise contours. For an initial baseline run, these values are set to 0.0. Card 9 contains the axis half-length, for plotting purposes, a year of population update, and a user-designated growth rate. The population values contained in the SITE II database are representative of the year 1981. If the user wishes to alter the population to represent a different year, the selected year should be specified on card 9. These populations will be altered according to the growth rate specified in the SITE II demographic profile reports, unless the user chooses to override that value by placing a growth rate on card 9. Card 10 contains the airport name, and card 11 contains the airport address.

TABLE III.-AIRPORT AUXILIARY FILE FORMAT
BASELINE SUBSYSTEM

<u>CARDS(S)</u>	<u>DATA</u>	<u>COLUMN(S)</u>	<u>FORMAT</u>
1 - 6			
7	Latitude		A10
	Degrees	1 - 2	
	Minutes	4 - 5	
	Seconds	7 - 8	
7	Longitude		A10
	Degrees	11 - 13	
	Minutes	15 - 16	
	Seconds	18 - 19	
7	N/S Displacement		A10
	N/S Indicator	25	
	Displacement Value	26 - 30	
7	E/W Displacement		A7
	E/W Indicator	32	
	Displacement Value	33 - 37	
8	X-Axis Translation Value	1 - 10	F10.2
8	Y-Axis Translation Value	11 - 20	F10.2
9	Axis Half-length	1 - 5	F5.2
9	Year of Population Update	7 - 10	I4
9	User-designated Growth Rate	12 - 16	F5.1
10	Airport Name	1 - 80	80A1
11	Airport Address	1 - 80	80A1

3.2.2 File naming conventions

File naming conventions.- The basic identifier used in the ALAMO file-naming conventions is a unique 3-character string associated with each airport, as determined by the Federal Aviation Administration. Appendix C contains a partial list of F.A.A. identifiers. This 3-character prefix, here symbolized by XXX, is used with all airport-specific files associated with an ALAMO Baseline run. User-created files should be named according to the conventions illustrated in Table IV. Baseline-generated files can be identified in the same manner. Strict adherence to the integer suffixes is also recommended, in order to provide a consistent means of file identification.

TABLE IV.-BASELINE FILE NAMING CONVENTIONS

<u>FILE NAME</u>	<u>FILE IDENTIFICATION</u>
XXX	Airport Auxiliary File
XXX001	Airport Description Data Deck
XXX002	INM Listable Output
XXX003	INM Contour Points
XXX004	SITE II Card Images
XXX005	Plot Vector File
XXX006	Partial SITE II Output
XXX007	Full SITE II Output
XXX008	Noise Impact Summary Report
XXXR	Noise Impact Summary Report(s)

XXX = Unique Federal Aviation Administration Identifier

3.2.3 Preliminary Procession

Preliminary Processing.- Preliminary processing for a baseline run involves 2 unrelated steps. The first step is the initialization of the tapes that will hold all files produced by ALAMO related software for the airport under study. The second preprocessing step involves the use of the INM VERIFY option, a feature that affords the user the ability to analyze the Airport Description Data Deck for possible errors, prior to the submission of a full baseline run.

3.2.3.1 Tape Initialization

Tape initialization: Prior to the execution of the baseline subsystem, the user must request and initialize two tapes per airport under study for ALAMO system usage. The first of these tapes is used by ALAMO to store by name all files generated for a specific airport, subsequent to successful baseline subsystem execution. The second tape is intended to contain all files generated by a baseline run when an error in processing occurs. All files created up to the time of encountering the error are saved by name on the designated tape.

These stored files can be retrieved later by the user when diagnosing the source of error. For an explanation of the CYBER Control Language used in tape initialization, the user is referred to the LABEL statement in the NOS User's Guide. The user should note that the file chosen for initialization is the Airport Auxiliary File. Initialization can be accomplished through the use of an appropriately-edited copy of the submit file, illustrated by Figure 2; the figure contains editing notes to facilitate submit file creation. The user should note that these tapes must be initialized only once; subsequent execution of initialization procedures, after any ALAMO system processing, will cause any data previously written to the tape to be lost.

3.2.3.2 Verify

Verify: The INM VERIFY option is a feature available to the user in order to diagnose errors in the highly-complex Airport Description Data Deck. This option is recommended to the user in order to eliminate INM input errors in a cost-effective manner. This option can be invoked in the following manner: the title card of the Airport Description Data Deck is replaced by a card containing the characters VERIFY, left justified to column 1. A job is then submitted to execute this input case with the absolutes of the INM Contour Program. The appropriate submit file, shown in Figure 3, illustrates the CCL required to perform an INM VERIFY run; here, XXX001 is the Airport Description Data Deck, with the VERIFY card in the place of the original title card. Once the user has reviewed the results of a VERIFY run, and has corrected any indicated errors in input, the user must replace the VERIFY card with the original title card. The Airport Description Data Deck is then ready for use with the baseline subsystem.

3.2.4 CYBER Control Language

CYBER Control language.- This section provides illustrations of the CYBER Control Language (CCL) required to execute the following jobs: tape initialization (Figure 2), a VERIFY run (Figure 3), and ALAMO baseline execution (Figure 4). Figures include editing notes to aid the user in submit file creation. The CCL required for ALAMO baseline execution is primarily contained in the Multi-Procedure file, A2; Appendix B, ALAMO MULTI-PROCEDURE FILE, contains a listing of the statements found in this file. Due to the length and complexity of the procedure file, the user is referred to the NOS User's Guide for an explanation of the control statements involved. For any ALAMO-related job execution, the user need only create an appropriately edited copy of the sample submit file, ensure that the required program modules and ALAMO input files are online, and then submit the file for execution. It is recommended that the user submit the ALAMO baseline job to a CYBER 175 (R or T machine), due to the large amount of execution time required to accomplish system execution.

```
INIJOB,T100,CM150000.                DELIVERY INFO
USER,...
CHARGE,.....,LRC.
VSN(TAPE51=NYYYYY,TAPE52=NZZZZZ)
BEGIN,D1,A2,XXX.
EXIT.
```

EDITING NOTES:

- INSERT ACTUAL REEL NUMBERS IN VSN STATEMENT
- REPLACE XXX WITH F.A.A. IDENTIFIERS
- TAPES NYYYYY AND NZZZZZ MUST FIRST BE ASSIGNED TO USER

Figure 2.-Submit file for Tape Initialization job.

```
VERJOB,T100,CM270000.                DELIVERY INFO
USER,...
CHARGE,.....,LRC.
ATTACH,CONTORA.
GET,XXX001.
CONTORA,XXX001,VEROUT.
ROUTE,VEROUT,DC=LP.
EXIT.
```

EDITING NOTES:

- REPLACE XXX WITH F.A.A. IDENTIFIERS

Figure 3.-Submit file for Baseline Verify job.

BASJOB,T12000,CM270000.

DELIVERY INFO

USER,...

CHARGE,.....,LRC.

VSN(TAPE51=NYYYYY,TAPE52=NZZZZZ)

SET(R3=0)

BEGIN,A1,A2,XXX001,XXX002,XXX003,XXX004,XXX005,XXX006,XXX007,XXX008,XXXR,XXX.

REWIND,TAPE6.

ROUTE,TAPE6,DC=LP.

EXIT.

EDITING NOTES:

- INSERT ACTUAL REEL NUMBERS IN VSN STATEMENT
- REPLACE XXX WITH F.A.A. IDENTIFIER
- IF NO ERROR, RUN INFORMATION WRITTEN TO TAPE 51. IF THERE IS AN ERROR, IT IS WRITTEN TO TAPE 52
- TAPE 6 IS FILE RECEIVING DEMOGRAPHIC OUTPUT REPORTS

Figure 4.--Submit file for primary Baseline job.

3.2.5 Restrictions

Restrictions.- Prior to the submission of an ALAMO baseline run, the user must satisfy 4 requirements pertaining to the Airport Description Data Deck. First, the user is required to place the case title on the title card, in columns 41 through 80; for the baseline run, the characters BASELINE would be left-justified to column 41. This information is later extracted to appropriately label the ALAMO-generated plot and reports. Columns 1-40 should be utilized for airport identification; this information will be reflected on the INM output, and can be used to distinguish data among airports, when case running in a multi-airport mode. The 3 remaining requirements for an Airport Description Data Deck pertain to the contour section of the input case. The user is referred to the Integrated Noise Model Version 2 User's Guide. For ALAMO baseline use, it is recommended that 5 specific contour values be requested, ordered in the following manner: 65, 70, 75, 80, and -85. Columns 6 through 10, intended to contain an option indicator for finding discrete "islands" of equal noise exposure, should be left blank. Finally, the INM uses a default value of 250 points for the maximum number of points calculated, in an attempt to determine a contour; the user should override this value, for each contour entry, by placing the value 650 in columns 77, 78, and 79.

3.2.6 Sample Subsystem Results

Sample subsystem results.- Baseline subsystem results consist of the plot of noise footprints, as illustrated by Figure 5, and a 10-page demographics report, as illustrated by Figure 6. The plot of contours, or noise footprints, affords the user a visual representation, on an octant-by-octant basis, of the contour distribution in the airport community. Ten individual reports constitute the overall demographics report. The first 8 reports present the correlation of demographic variables with noise exposure levels, on an octant-by-octant basis. The ninth report is a demographic noise exposure report for all octants. The final report is an airport community noise impact report.

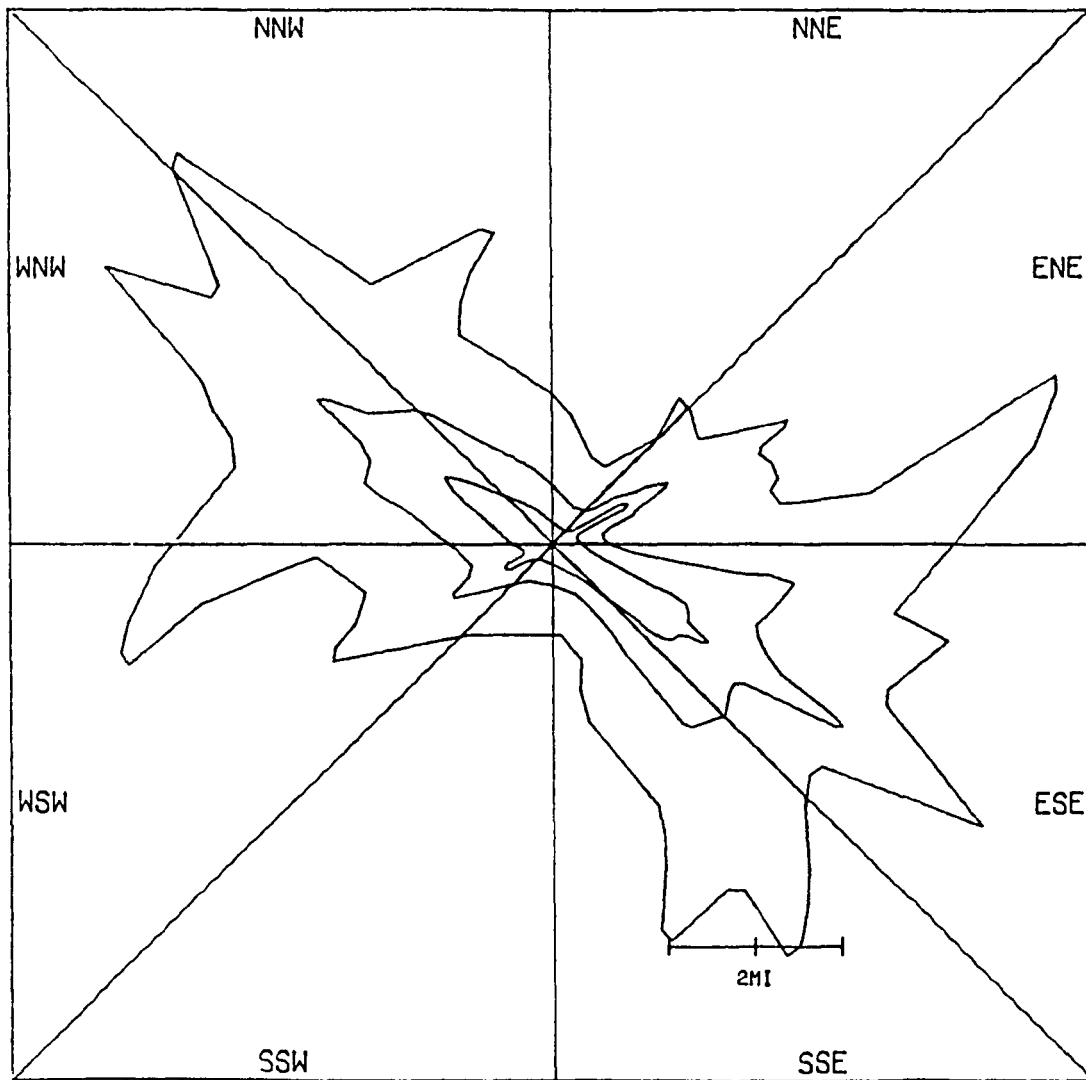

Figure 5. Baseline LDN footprint for major midwestern airport

A L A M O D E M O G R A P H I C N O I S E E X P O S U R E R E P O R T

AIRPORT: "REPRESENTATIVE MIDWESTERN AIRPORT"
 COMMUNITY: "REPRESENTATIVE MIDWESTERN COMMUNITY"
 CASE: BASELINE

OCTANT: ESE

I DEMOGRAPHIC VARIABLES I 1970 OR AS NOTED	I N O I S E D U E T O A I R P O R T , L D N I				
	I 65 - 70 I	I 70 - 75 I	I 75 - 80 I	I 80 - 85 I	I O V E R 85 I
I SELF-NOISE, LDN(1)(2) I	I 53 I	I 50 I	I 54 I	I 27 I	I 47 I
I IMPACTED POP(1) I	I 17395 I	I 6827 I	I 9127 I	I 10 I	I 839 I
I AREA, SQ KM I	I 7.90 I	I 5.98 I	I 3.34 I	I 1.76 I	I 1.63 I
I TOT POP / SQ KM(1) I	I 2202 I	I 1141 I	I 2733 I	I 6 I	I 514 I
I AVG GROWTH RATE, APR I	I -1.2 I	I -1.8 I	I -2.4 I	I -3.6 I	I -3.6 I
I PCT FAMILY POPULATION I	I 90.8 I	I 93.3 I	I 92.3 I	I 86.7 I	I 91.5 I
I AVG AGE, ADULTS > 17 I	I 43 I	I 41 I	I 41 I	I 40 I	I 43 I
I PCT AGE 65+ I	I 10.5 I	I 7.7 I	I 8.4 I	I 6.7 I	I 9.4 I
I PCT 16+ YRS ED(3) I	I 11.7 I	I 8.4 I	I 6.0 I	I 0.0 I	I 2.3 I
I PCT MGR/PROF I	I 26.8 I	I 20.7 I	I 15.4 I	I 0.0 I	I 7.0 I
I AVG FAMILY INCOME I	I 13778 I	I 12305 I	I 10630 I	I 5666 I	I 9547 I
I PCT SINGLE FAM DWL I	I 75.3 I	I 79.4 I	I 76.9 I	I 60.0 I	I 81.1 I
I PCT HOME OWNERS I	I 90.3 I	I 85.3 I	I 79.0 I	I 66.7 I	I 71.1 I
I AVG HOME VALUE I	I 17643 I	I 14958 I	I 12328 I	I 8750 I	I 9472 I
I PCT HH WITH A/C I	I 47.2 I	I 29.2 I	I 23.5 I	I 20.0 I	I 25.3 I
I PCT HH WITH TV I	I 92.3 I	I 90.6 I	I 88.4 I	I 80.0 I	I 86.2 I

(1) BASED ON 1981 POPULATION DATA UPDATED TO 1979
 (2) BASED ON POPULATION, AFTER GALLOWAY
 (3) ADULTS 25 YEARS OLD OR OLDER

3-28

Figure 6. - Report resulting from execution of Baseline subsystem.

A L A M O D E M O G R A P H I C N O I S E E X P O S U R E R E P O R T

AIRPORT: "REPRESENTATIVE MIDWESTERN AIRPORT"
 COMMUNITY: "REPRESENTATIVE MIDWESTERN COMMUNITY"
 CASE: BASELINE

OCTANT: SSE

I DEMOGRAPHIC VARIABLES I 1970 OR AS NOTED	I N O I S E D U E T O A I R P O R T , L D N I				
	I 65 - 70 I	I 70 - 75 I	I 75 - 80 I	I 80 - 85 I	I OVER 85 I
I SELF-NOISE, LDN(1)(2) I	I 52 I	I 52 I	I 49 I	I 0 I	I 0 I
I IMPACTED POP(1) I	I 16643 I	I 5408 I	I 1404 I	I 0 I	I 0 I
I AREA, SQ KM I	I 9.48 I	I 3.08 I	I 1.45 I	I .36 I	I .16 I
I TOT POP / SQ KM(1) I	I 1756 I	I 1755 I	I 968 I	I 0 I	I 0 I
I AVG GROWTH RATE, APR I	I -1.8 I	I -2.5 I	I -2.0 I	I 0.0 I	I 0.0 I
I PCT FAMILY POPULATION I	I 91.5 I	I 92.2 I	I 95.4 I	I 0.0 I	I 0.0 I
I AVG AGE, ADULTS > 17 I	I 42 I	I 41 I	I 40 I	I 0 I	I 0 I
I PCT AGE 65+ I	I 8.6 I	I 7.9 I	I 5.7 I	I 0.0 I	I 0.0 I
I PCT 16+ YPS ED(3) I	I 8.2 I	I 5.8 I	I 5.6 I	I 0.0 I	I 0.0 I
I PCT MGR/PROF I	I 22.3 I	I 19.4 I	I 19.4 I	I 0.0 I	I 0.0 I
I AVG FAMILY INCOME I	I 12595 I	I 11802 I	I 12484 I	I 0 I	I 0 I
I PCT SINGLE FAM DWL I	I 81.7 I	I 71.6 I	I 82.2 I	I 0.0 I	I 0.0 I
I PCT HOME OWNERS I	I 88.1 I	I 85.5 I	I 87.7 I	I 0.0 I	I 0.0 I
I AVG HOME VALUE I	I 15233 I	I 13975 I	I 14168 I	I 0 I	I 0 I
I PCT HH WITH A/C I	I 48.2 I	I 51.7 I	I 75.0 I	I 0.0 I	I 0.0 I
I PCT HH WITH TV I	I 94.0 I	I 93.8 I	I 97.0 I	I 0.0 I	I 0.0 I

(1) BASED ON 1991 POPULATION DATA UPDATED TO 1979
 (2) BASED ON POPULATION, AFTER GALLOWAY
 (3) ADULTS 25 YEARS OLD OR OLDER

3-29

Figure 6. - Continued.

A L A M O D E M O G R A P H I C N O I S E E X P O S U R E R E P O R T

AIRPORT: "REPRESENTATIVE MIDWESTERN AIRPORT"
 COMMUNITY: "REPRESENTATIVE MIDWESTERN COMMUNITY"
 CASE: BASELINE

OCTANT: 55W

I DEMOGRAPHIC VARIABLES I 1970 OR AS NOTED	I N O I S E D U E T O A I R P O R T , L D N I				
	I 65 - 70 I	I 70 - 75 I	I 75 - 80 I	I 80 - 85 I	I OVER 85 I
I SELF-NOISE, LDN(1)(2) I	I 56 I	I 0 I	I 0 I	I 0 I	I 0 I
I IMPACTED POP(1) I	I 3558 I	I 0 I	I 0 I	I 0 I	I 0 I
I AREA, SQ KM I	I .88 I	I .28 I	I .13 I	I .08 I	I .05 I
I TOT POP / SQ KM(1) I	I 4043 I	I 0 I	I 0 I	I 0 I	I 0 I
I AVG GROWTH RATE, APR I	I -1.7 I	I 0.0 I	I 0.0 I	I 0.0 I	I 0.0 I
I PCT FAMILY POPULATION I	I 90.5 I	I 0.0 I	I 0.0 I	I 0.0 I	I 0.0 I
I AVG AGE, ADULTS > 17 I	I 35 I	I 0 I	I 0 I	I 0 I	I 0 I
I PCT AGE 65+ I	I 2.8 I	I 0.0 I	I 0.0 I	I 0.0 I	I 0.0 I
I PCT 16+ YRS ED(3) I	I 13.2 I	I 0.0 I	I 0.0 I	I 0.0 I	I 0.0 I
I PCT MGR/PROF I	I 25.3 I	I 0.0 I	I 0.0 I	I 0.0 I	I 0.0 I
I AVG FAMILY INCOME I	I 11860 I	I 0 I	I 0 I	I 0 I	I 0 I
I PCT SINGLE FAM DWL I	I 55.3 I	I 0.0 I	I 0.0 I	I 0.0 I	I 0.0 I
I PCT HOME OWNERS I	I 80.2 I	I 0.0 I	I 0.0 I	I 0.0 I	I 0.0 I
I AVG HOME VALUE I	I 14435 I	I 0 I	I 0 I	I 0 I	I 0 I
I PCT HH WITH A/C I	I 79.0 I	I 0.0 I	I 0.0 I	I 0.0 I	I 0.0 I
I PCT HH WITH TV I	I 88.3 I	I 0.0 I	I 0.0 I	I 0.0 I	I 0.0 I

(1) BASED ON 1981 POPULATION DATA UPDATED TO 1979
 (2) BASED ON POPULATION, AFTER GALLOWAY
 (3) ADULTS 25 YEARS OLD OR OLDER

3-30

Figure 6. - Continued.

A L A M O D E M O G R A P H I C N O I S E E X P O S U R E R E P O R T

AIRPORT: "REPRESENTATIVE MIDWESTERN AIRPORT"
 COMMUNITY: "REPRESENTATIVE MIDWESTERN COMMUNITY"
 CASE: BASELINE

OCTANT: WSW

I DEMOGRAPHIC VARIABLES I 1970 OR AS NOTED	I N O I S E D U E T O A I R P O R T , L D N I				
	I 65 - 70 I	I 70 - 75 I	I 75 - 80 I	I 80 - 85 I	I O V E R 8 5 I
I SELF-NOISE, LDN(1)(2) I	I 49 I	I 54 I	I 0 I	I 0 I	I 0 I
I IMPACTED POP(1) I	I 6145 I	I 4242 I	I 0 I	I 0 I	I 0 I
I AREA, SQ KM I	I 6.24 I	I 1.55 I	I .65 I	I .26 I	I .18 I
I TOT POP / SQ KM(1) I	I 985 I	I 2731 I	I 0 I	I 0 I	I 0 I
I AVG GROWTH RATE, APR I	I 2.2 I	I -2.2 I	I 0.0 I	I 0.0 I	I 0.0 I
I PCT FAMILY POPULATION I	I 98.7 I	I 88.7 I	I 0.0 I	I 0.0 I	I 0.0 I
I AVG AGE, ADULTS > 17 I	I 35 I	I 35 I	I 0 I	I 0 I	I 0 I
I PCT AGE 65+ I	I 2.1 I	I 2.7 I	I 0.0 I	I 0.0 I	I 0.0 I
I PCT 16+ YRS ED(3) I	I 9.2 I	I 14.0 I	I 0.0 I	I 0.0 I	I 0.0 I
I PCT MGR/PROF I	I 23.2 I	I 26.0 I	I 0.0 I	I 0.0 I	I 0.0 I
I AVG FAMILY INCOME I	I 12610 I	I 11613 I	I 0 I	I 0 I	I 0 I
I PCT SINGLE FAM DWL I	I 95.2 I	I 51.1 I	I 0.0 I	I 0.0 I	I 0.0 I
I PCT HOME OWNERS I	I 91.7 I	I 78.3 I	I 0.0 I	I 0.0 I	I 0.0 I
I AVG HOME VALUE I	I 18512 I	I 14483 I	I 0 I	I 0 I	I 0 I
I PCT HH WITH A/C I	I 0.0 I	I 80.8 I	I 0.0 I	I 0.0 I	I 0.0 I
I PCT HH WITH TV I	I 92.2 I	I 88.8 I	I 0.0 I	I 0.0 I	I 0.0 I

(1) BASED ON 1981 POPULATION DATA UPDATED TO 1979
 (2) BASED ON POPULATION, AFTER GALLOWAY
 (3) ADULTS 25 YEARS OLD OR OLDER

Figure 6. - Continued.

A L A M O D E M O G R A P H I C N O I S E E X P O S U R E R E P O R T

AIRPORT: "REPRESENTATIVE MIDWESTERN AIRPORT"
 COMMUNITY: "REPRESENTATIVE MIDWESTERN COMMUNITY"
 CASE: BASELINE

OCTANT: WNW

I DEMOGRAPHIC VARIABLES I 1970 OR AS NOTED	I N O I S E D U E T O A I R P O R T , L D N I				
	I 65 - 70 I	I 70 - 75 I	I 75 - 80 I	I 80 - 85 I	I O V E R 8 5 I
I SELF-NOISE, LDN(1)(2) I	I 48 I	I 48 I	I 42 I	I 42 I	I 0 I
I IMPACTED POP(1) I	I 8282 I	I 3295 I	I 425 I	I 240 I	I 0 I
I AREA, SQ KM I	I 11.37 I	I 5.20 I	I 2.64 I	I 1.35 I	I .88 I
I TOT POP / SQ KM(1) I	I 728 I	I 633 I	I 161 I	I 178 I	I 0 I
I AVG GROWTH RATE, APR I	I -1.4 I	I -2.1 I	I -8.3 I	I -8.3 I	I 0.0 I
I PCT FAMILY POPULATION I	I 94.3 I	I 93.9 I	I 73.7 I	I 73.8 I	I 0.0 I
I AVG AGE, ADULTS > 17 I	I 37 I	I 37 I	I 32 I	I 32 I	I 0 I
I PCT AGE 65+ I	I 2.8 I	I 2.8 I	I 2.4 I	I 2.5 I	I 0.0 I
I PCT 16+ YRS ED(3) I	I 23.3 I	I 23.4 I	I 20.7 I	I 20.9 I	I 0.0 I
I PCT MGR/PROF I	I 38.5 I	I 38.8 I	I 31.1 I	I 31.1 I	I 0.0 I
I AVG FAMILY INCOME I	I 15830 I	I 15313 I	I 9557 I	I 9500 I	I 0 I
I PCT SINGLE FAM DWL I	I 71.9 I	I 65.8 I	I 25.9 I	I 26.0 I	I 0.0 I
I PCT HOME OWNERS I	I 87.0 I	I 87.8 I	I 59.3 I	I 56.3 I	I 0.0 I
I AVG HOME VALUE I	I 24146 I	I 23798 I	I 15895 I	I 15625 I	I 0 I
I PCT HH WITH A/C I	I 0.0 I	I 1.4 I	I 91.3 I	I 91.1 I	I 0.0 I
I PCT HH WITH TV I	I 96.0 I	I 95.8 I	I 91.5 I	I 91.5 I	I 0.0 I

(1) BASED ON 1981 POPULATION DATA UPDATED TO 1979
 (2) BASED ON POPULATION, AFTER GALLOWAY
 (3) ADULTS 25 YEARS OLD OR OLDER

A L A M O D E M O G R A P H I C N O I S E E X P O S U R E R E P O R T

AIRPORT: "REPRESENTATIVE MIDWESTERN AIRPORT"
 COMMUNITY: "REPRESENTATIVE MIDWESTERN COMMUNITY"
 CASE: BASELINE

OCTANT: NNW

I DEMOGRAPHIC VARIABLES I 1970 OR AS NOTED	I N O I S E D U E T O A I R P O R T , L D N I				
	I 65 - 70 I	I 70 - 75 I	I 75 - 80 I	I 80 - 85 I	I O V E R 8 5 I
I SELF-NOISE, LDN(1)(2) I	I 48 I	I 0 I	I 49 I	I 0 I	I 0 I
I IMPACTED POP(1) I	I 5824 I	I 0 I	I 858 I	I 0 I	I 0 I
I AREA, SQ KM I	I 8.72 I	I 2.28 I	I .96 I	I .36 I	I .21 I
I TOT POP / SQ KM(1) I	I 667 I	I 0 I	I 896 I	I 0 I	I 0 I
I AVG GROWTH RATE, APR I	I -.1 I	I 0.0 I	I -.1 I	I 0.0 I	I 0.0 I
I PCT FAMILY POPULATION I	I 97.0 I	I 0.0 I	I 97.0 I	I 0.0 I	I 0.0 I
I AVG AGE, ADULTS > 17 I	I 37 I	I 0 I	I 37 I	I 0 I	I 0 I
I PCT AGE 65+ I	I 3.4 I	I 0.0 I	I 3.3 I	I 0.0 I	I 0.0 I
I PCT 16+ YRS ED(3) I	I 7.7 I	I 0.0 I	I 7.7 I	I 0.0 I	I 0.0 I
I PCT MGR/PROF I	I 23.6 I	I 0.0 I	I 23.6 I	I 0.0 I	I 0.0 I
I AVG FAMILY INCOME I	I 11978 I	I 0 I	I 11924 I	I 0 I	I 0 I
I PCT SINGLE FAM DWL I	I 83.6 I	I 0.0 I	I 83.4 I	I 0.0 I	I 0.0 I
I PCT HOME OWNERS I	I 84.6 I	I 0.0 I	I 84.7 I	I 0.0 I	I 0.0 I
I AVG HOME VALUE I	I 17706 I	I 0 I	I 17650 I	I 0 I	I 0 I
I PCT HH WITH A/C I	I 73.1 I	I 0.0 I	I 73.2 I	I 0.0 I	I 0.0 I
I PCT HH WITH TV I	I 89.8 I	I 0.0 I	I 89.8 I	I 0.0 I	I 0.0 I

(1) BASED ON 1981 POPULATION DATA UPDATED TO 1979
 (2) BASED ON POPULATION, AFTER GALLOWAY
 (3) ADULTS 25 YEARS OLD OR OLDER

Figure 6. - Continued.

A L A M O D E M O G R A P H I C N O I S E E X P O S U R E R E P O R T

AIRPORT: "REPRESENTATIVE MIDWESTERN AIRPORT"
 COMMUNITY: "REPRESENTATIVE MIDWESTERN COMMUNITY"
 CASE: BASELINE

OCTANT: NNE

I DEMOGRAPHIC VARIABLES I 1970 OR AS NOTED	I N O I S E D U E T O A I R P O R T , L D N I				
	I 65 - 70 I	I 70 - 75 I	I 75 - 80 I	I 80 - 85 I	I OVER 85 I
I SELF-NOISE, LDN(1)(2) I	I 49 I	I 0 I	I 0 I	I 0 I	I 0 I
I IMPACTED POP(1) I	I 1163 I	I 0 I	I 0 I	I 0 I	I 0 I
I AREA, SQ KM I	I 1.27 I	I .41 I	I .16 I	I .08 I	I .05 I
I TOT POP / SQ KM(1) I	I 916 I	I 0 I	I 0 I	I 0 I	I 0 I
I AVG GROWTH RATE, APR I	I -1.7 I	I 0.0 I	I 0.0 I	I 0.0 I	I 0.0 I
I PCT FAMILY POPULATION I	I 96.7 I	I 0.0 I	I 0.0 I	I 0.0 I	I 0.0 I
I AVG AGE, ADULTS > 17 I	I 39 I	I 0 I	I 0 I	I 0 I	I 0 I
I PCT AGE 65+ I	I 3.8 I	I 0.0 I	I 0.0 I	I 0.0 I	I 0.0 I
I PCT 16+ YRS ED(3) I	I 9.8 I	I 0.0 I	I 0.0 I	I 0.0 I	I 0.0 I
I PCT MGR/PROF I	I 23.6 I	I 0.0 I	I 0.0 I	I 0.0 I	I 0.0 I
I AVG FAMILY INCOME I	I 13833 I	I 0 I	I 0 I	I 0 I	I 0 I
I PCT SINGLE FAM DWL I	I 89.7 I	I 0.0 I	I 0.0 I	I 0.0 I	I 0.0 I
I PCT HOME OWNERS I	I 82.5 I	I 0.0 I	I 0.0 I	I 0.0 I	I 0.0 I
I AVG HOME VALUE I	I 16881 I	I 0 I	I 0 I	I 0 I	I 0 I
I PCT HH WITH A/C I	I 0.0 I	I 0.0 I	I 0.0 I	I 0.0 I	I 0.0 I
I PCT HH WITH TV I	I 89.9 I	I 0.0 I	I 0.0 I	I 0.0 I	I 0.0 I

(1) BASED ON 1981 POPULATION DATA UPDATED TO 1979
 (2) BASED ON POPULATION, AFTER GALLOWAY
 (3) ADULTS 25 YEARS OLD OR OLDER

3-34

A L A M O D E M O G R A P H I C N O I S E E X P O S U R E R E P O R T

AIRPORT: "REPRESENTATIVE MIDWESTERN AIRPORT"
 COMMUNITY: "REPRESENTATIVE MIDWESTERN COMMUNITY"
 CASE: BASELINE

OCTANT: ENE

I DEMOGRAPHIC VARIABLES I 1970 OR AS NOTED	I N O I S E D U E T O A I R P O R T , L D N I				
	I 65 - 70 I	I 70 - 75 I	I 75 - 80 I	I 80 - 85 I	I OVER 85 I
I SELF-NOISE, LDN(1)(2) I	I 53 I	I 53 I	I 0 I	I 0 I	I 0 I
I IMPACTED POP(1) I	I 24539 I	I 2694 I	I 0 I	I 0 I	I 0 I
I AREA, SQ KM I	I 10.74 I	I 1.35 I	I .41 I	I .23 I	I .21 I
I TOT POP / SQ KM(1) I	I 2284 I	I 2001 I	I 0 I	I 0 I	I 0 I
I AVG GROWTH RATE, APR I	I -.9 I	I -1.8 I	I 0.0 I	I 0.0 I	I 0.0 I
I PCT FAMILY POPULATION I	I 97.3 I	I 96.8 I	I 0.0 I	I 0.0 I	I 0.0 I
I AVG AGE, ADULTS > 17 I	I 41 I	I 39 I	I 0 I	I 0 I	I 0 I
I PCT AGE 65+ I	I 4.9 I	I 3.6 I	I 0.0 I	I 0.0 I	I 0.0 I
I PCT 16+ YRS ED(3) I	I 10.4 I	I 7.7 I	I 0.0 I	I 0.0 I	I 0.0 I
I PCT MGR/PROF I	I 25.4 I	I 20.5 I	I 0.0 I	I 0.0 I	I 0.0 I
I AVG FAMILY INCOME I	I 14059 I	I 12599 I	I 0 I	I 0 I	I 0 I
I PCT SINGLE FAM OWL I	I 94.6 I	I 92.5 I	I 0.0 I	I 0.0 I	I 0.0 I
I PCT HOME OWNERS I	I 90.4 I	I 84.4 I	I 0.0 I	I 0.0 I	I 0.0 I
I AVG HOME VALUE I	I 18978 I	I 15015 I	I 0 I	I 0 I	I 0 I
I PCT HH WITH A/C I	I 37.7 I	I 38.3 I	I 0.0 I	I 0.0 I	I 0.0 I
I PCT HH WITH TV I	I 91.5 I	I 91.8 I	I 0.0 I	I 0.0 I	I 0.0 I

(1) BASED ON 1981 POPULATION DATA UPDATED TO 1979
 (2) BASED ON POPULATION, AFTER GALLOWAY
 (3) ADULTS 25 YEARS OLD OR OLDER

Figure 6. - Continued.

A L A M O D E M O G R A P H I C N O I S E E X P O S U R E R E P O R T

AIRPORT: "REPRESENTATIVE MIDWESTERN AIRPORT"
 COMMUNITY: "REPRESENTATIVE MIDWESTERN COMMUNITY"
 CASE: BASELINE

OCTANT: ALL OCTANTS

I DEMOGRAPHIC VARIABLES I 1970 OR AS NOTED	I N O I S E D U E T O A I R P O R T , L D N I				
	I 65 - 70 I	I 70 - 75 I	I 75 - 80 I	I 80 - 85 I	I OVER 85 I
I SELF-NOISE, LDN(1)(2) I	I 51 I	I 50 I	I 50 I	I 37 I	I 43 I
I IMPACTED POP(1) I	I 83553 I	I 22468 I	I 11816 I	I 250 I	I 839 I
I AREA, SQ KM I	I 56.59 I	I 20.14 I	I 9.73 I	I 4.48 I	I 3.37 I
I TOT POP / SQ KM(1) I	I 1476 I	I 1115 I	I 1213 I	I 56 I	I 249 I
I AVG GROWTH RATE, APR I	I -1.0 I	I -2.1 I	I -2.4 I	I -8.1 I	I -3.6 I
I PCT FAMILY POPULATION I	I 94.1 I	I 92.6 I	I 91.7 I	I 74.2 I	I 91.5 I
I AVG AGE, ADULTS > 17 I	I 40 I	I 39 I	I 40 I	I 32 I	I 43 I
I PCT AGE 65+ I	I 6.3 I	I 5.6 I	I 7.4 I	I 2.6 I	I 9.4 I
I PCT 16+ YRS ED(3) I	I 11.3 I	I 10.7 I	I 6.9 I	I 20.4 I	I 2.3 I
I PCT MGR/PROF I	I 26.1 I	I 24.1 I	I 17.8 I	I 30.7 I	I 7.0 I
I AVG FAMILY INCOME I	I 13547 I	I 12491 I	I 10860 I	I 9417 I	I 8547 I
I PCT SINGLE FAM DWL I	I 82.2 I	I 70.7 I	I 72.9 I	I 26.7 I	I 81.1 I
I PCT HOME OWNERS I	I 88.8 I	I 84.4 I	I 79.7 I	I 56.7 I	I 71.1 I
I AVG HOME VALUE I	I 18024 I	I 15771 I	I 13012 I	I 15263 I	I 9472 I
I PCT HH WITH A/C I	I 40.5 I	I 43.6 I	I 36.4 I	I 89.6 I	I 25.3 I
I PCT HH WITH TV I	I 92.5 I	I 91.9 I	I 89.7 I	I 91.2 I	I 86.2 I

(1) BASED ON 1981 POPULATION DATA UPDATED TO 1979
 (2) BASED ON POPULATION, AFTER GALLOJAY
 (3) ADULTS 25 YEARS OLD OR OLDER

Figure 6. - Continued.

ALAMO AIRPORT COMMUNITY NOISE IMPACT SUMMARY

AIRPORT: "REPRESENTATIVE MIDWESTERN AIRPORT"
 COMMUNITY: "REPRESENTATIVE MIDWESTERN COMMUNITY"
 CASE: BASELINE

	ENE	NNE	NNW	WNW	WSW	SSW	SSE	ESE	TOTAL
IMPACTED POPULATION	27233	1163	6682	12242	10387	3558	23455	34198	118918
LEVEL WEIGHTED POP	14456	584	3921	7641	6430	1788	14250	26356	75426
NOISE IMPACT INDEX	.531	.502	.587	.624	.619	.503	.608	.771	.634
EQUIVALENT NOISE LEVEL	67	66	68	69	69	66	68	71	69
PERCENT HIGHLY ANNOYED	19.6	18.5	21.7	23.0	22.8	18.5	22.4	28.4	23.4
POP HIGHLY ANNOYED	5334	215	1446	2819	2372	659	5258	9725	27832
65 DB CONTOUR, SQ KM	12.94	1.97	12.53	21.44	8.88	1.42	14.52	20.61	94.31
75 DB CONTOUR, SQ KM	.85	.28	1.53	4.87	1.09	.26	1.97	6.73	17.58
85 DB CONTOUR, SQ KM	.21	.05	.21	.88	.18	.05	.16	1.63	3.37

Figure 6. - Concluded.

3-37

3.2.7 Case Runner's Checklist

Case runner's checklist.- Case running can be facilitated through the use of the checklist provided by Figure 7. It is recommended that the case runner utilize a copy of the checklist while gathering airport-related information, and while stepping through the various baseline procedures. The completed checklist will serve as a record of relevant information pertaining to a specific baseline run.

- _____ Create/obtain Airport Description Data Deck
- _____ Collect information for Airport Auxiliary File
 - Airport Latitude :
 - Airport Longitude:
 - Airport Name :
 - Airport Address :
- _____ Obtain F.A.A. Airport Identifier
XXX =
- _____ Create Airport Auxiliary File on CPFS cluster with file name XXX
- _____ Modify Airport Description Data Deck according to restrictions (save on CPFS cluster as XXX001)
- _____ Extract program modules, INM database, and ALAMO procedure files from tape
- _____ Request 2 tapes for airport-specific file storage
 - Reel 1 :
 - Reel 2 :
- _____ Initialize tapes
- _____ Perform VERIFY run
 - o Insert VERIFY card in XXX001, and replace file
 - o Execute VERIFY run
 - o Correct input errors, if any
 - o Replace XXX001 with original title card
- _____ Set-up SITE II database files
- _____ Submit CCL for ALAMO baseline run
- _____ List labels on Reel 1 and Reel 2 (use LISTLB statement)
- _____ Perform file management (purge unnecessary files)

Figure 7.-Case Runner's checklist for Baseline subsystem.

NOTES AND COMMENTS

NOISE REDUCTION SIMULATION SUBSYSTEM

4.0 NOISE REDUCTION SIMULATION SUBSYSTEM

The Noise Reduction Simulation (NRS) subsystem is designed to simulate a series of reductions in aircraft noise, in order to establish the correlation between noise impact index and an equivalent source noise reduction. This simulation is accomplished through a series of modifications to the Integrated Noise Model (INM) database, in which noise level values associated with aircraft performance, are modified to reflect a corresponding reduction in source noise. The modified database is then used, in conjunction with the modules of the Baseline subsystem, to generate and overlay aircraft noise footprints on the population distribution of a designated airport. The resultant noise impact index is then evaluated as a function of the reduction in source noise. Simulations are accomplished for 7 cases representing database noise level modifications of -4 decibels (dB), -2 dB, and from 2 dB to 10 dB, in 2 dB steps.

Input to the NRS subsystem consists of the Airport Description Data Decks and the INM database. The primary output produced is a plot containing 2 frames; frame 1 represents the tabulated results of the source noise reduction, and the associated noise impact index; frame 2 contains a graphical display of the noise impact index versus the source noise reduction.

The modules of the Baseline subsystem are the core of the NRS subsystem; additionally, files generated or modified by the Baseline subsystem are required as input to the NRS subsystem. Consequently, the user must be familiar with the construction and use of the Baseline subsystem in order to proceed with NRS subsystem use.

Subsystem Architecture

4.1 Subsystem Architecture

The Noise Reduction Simulation subsystem utilizes 3 modules, in addition to the core modules required by a Baseline run. Those additional modules are the CYBER Control Language Generator, the INM database Modifier, and the Plot/Report Generator. A block diagram of this subsystem is illustrated by Figure 8. Module input/output specifications can be found in Table V, where both file descriptions and file names are denoted. The user should note that figure 8 represents the Baseline subsystem as a single block. A block diagram expansion of that subsystem, along with the corresponding module descriptions, can be found in Figure 1 and Table I. Modules unique to the NRS subsystem are described below.

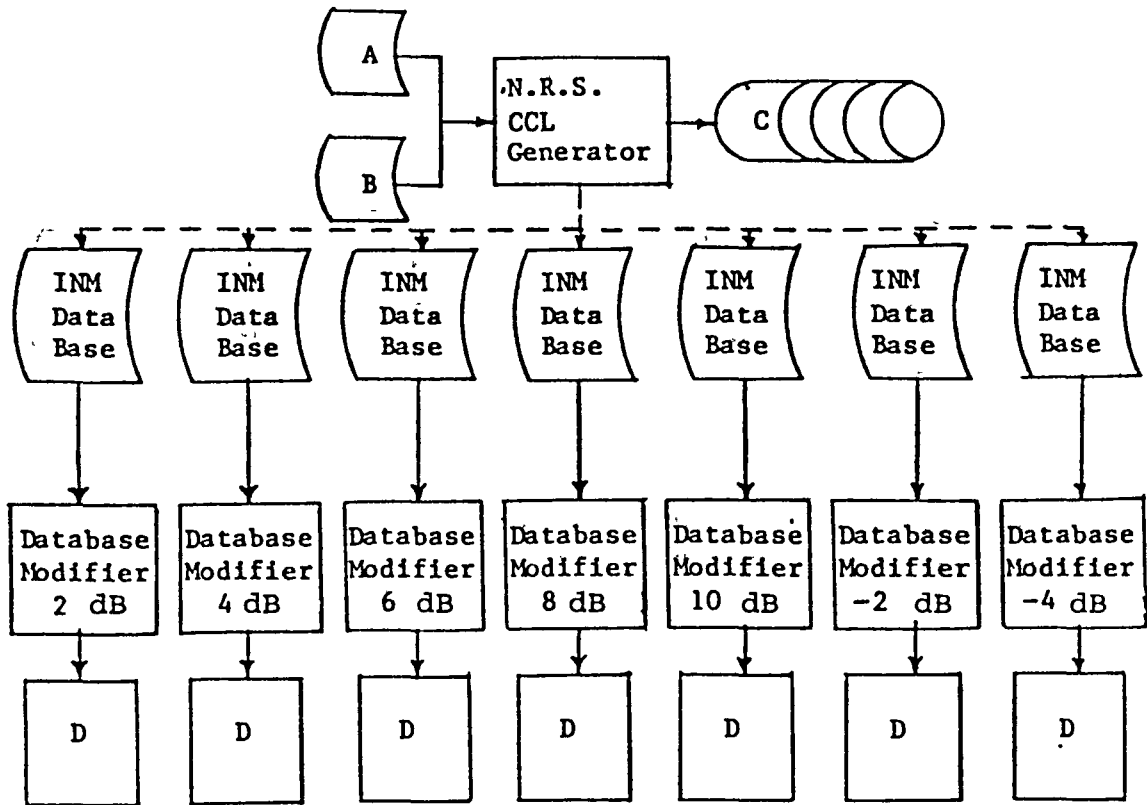

Legend:

----- Job Submittal

————— Flow of Execution

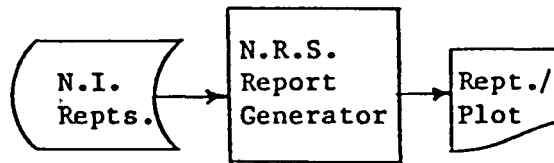

- A - Airport Description Data
- B - Airport Auxiliary File
- C - Modified Airport Description Data
- D - Baseline Subsystem

Figure 8.-Block diagram of Noise Reduction Simulation subsystem.

TABLE V.--NOISE REDUCTION SIMULATION MODULE SPECIFICATIONS

CYBER CONTROL LANGUAGE GENERATOR

NAME : NOIRD1A
FUNCTION : Creation of INM Input Decks and Submit Files
INPUT : Airport Auxiliary File (TAPE1/XXX)
Airport Description Data Deck (TAPE2/XXX001)
OUTPUT : CYBER Control Language (TAPE3)
Error Messages (TAPE8)
SCRATCH : None

INM DATA BASE MODIFIER

NAME : NOIRD2A
FUNCTION : Modification of Standard INM Database
INPUT : INM Database (TAPE1)
OUTPUT : Modified INM Database (TAPE7)
SCRATCH : None

PLOT/REPORT GENERATOR

NAME : NRSRPTA
FUNCTION : Evaluation of Noise Impact Index and Source Noise
Reduction
INPUT : file of Noise Impact Summary Reports (TAPE5)
OUTPUT : Plot Vector File (SAVPLT)
Auxiliary Information (TAPE6)
SCRATCH : TAPE7

4.1.1 CYBER Control Language Generator

CYBER Control Language Generator.- The CYBER Control Language (CCL) Generator has the 2 following functions: to create 7 variations of the Airport Description Data Deck, and to generate the CCL necessary to process those decks in parallel, using the modules of the Baseline subsystem and a modified version of the INM database. The 7 Airport Description Data Decks differ only in the card image that contains the case name; this name reflects the decibel reduction factor used in the modification of the INM database. The CCL generated for each deck includes statements to invoke the INM Database Modifier, and then to execute the modules of the Baseline subsystem, using an appropriately modified version of the INM database.

Input to the CCL Generator is the baseline Airport Description Data Deck. Output consists of the 7 variations of the Airport Description Data Deck, and the 7 corresponding sets of CCL required to process those decks. The user need not be concerned with output file handling; all file handling is accomplished by the module itself, during execution.

4.1.2 INM Database Modifier

INM Database Modifier.- The INM Database Modifier adjusts the aircraft noise level values in a copy of the INM database; the result is a database of aircraft noise and performance that can be used to simulate a specific source noise reduction. The modified database is used as input to the modules of the ALAMO Baseline subsystem, resulting in a Noise Impact Summary Report that reflects the impact of airport operations of the surrounding community. The INM Database Modifier uses, as input, a copy of the standard INM database. A job control register is then sampled to determine the factor, in decibels, to be used in the adjustment of the noise level values. Output from this module is a copy of the INM database, with documented noise levels. During execution of the Noise Reduction Simulation subsystem, 7 modified copies of the INM database are produced, representing noise level values adjusted by -4 dB, -2 dB, and from 2 dB to 10 dB, in 2 dB increments.

4.1.3 Plot/Report Generator

Plot/Report Generator.- The Plot/Report Generator is the final module in the NRS subsystem. It is executed only after the successful completion of the 7 jobs initiated by the CCL Generator. The Plot/Report Generator searches a file of Noise Impact Summary reports for the noise impact index associated with each of 8 runs, including the 7 NRS subsystem ALAMO runs and the Baseline run. The noise impact index and the associated reduction in database noise values are plotted, both in tabulated and graphical form. Input to the Plot/Report Generator is the file of Noise Impact Summary Reports. Output from this module is a plot vector file that illustrates the functional relationship between the noise impact index and the equivalent source noise reduction.

Subsystem Usage

4.2 Subsystem Usage

To execute the Noise Reduction Simulation subsystem, the user must accomplish the following steps:

1. File Modification and Retrieval
2. Submission of appropriate CCL to execute subsystem

Procedure descriptions follow, along with a description of the file naming conventions used, sample subsystem results, and a case runner's checklist.

4.2.1.1 File Modification and Retrieval

File modification and retrieval: The five following categories of files must be retrieved or modified for a Noise Reduction Simulation subsystem run:

1. Program modules and execution procedures
2. SITE II Demographic Data
3. Airport Description Data Deck
4. Airport Auxiliary File
5. Baseline Noise Impact Summary Report

Files in categories 1 and 2 reside on tape, and retrieval procedures are described below. The Airport Description Data Deck, used by the Baseline subsystem, and the Noise Impact Summary Report, produced by the Baseline subsystem, must be available as indirect access files. The Airport Auxiliary File, used by the Baseline subsystem, must be modified.

Program Modules

ALAMO Baseline program modules, the INM database, and the ALAMO multi-procedure file must be brought on line prior to NRS

subsystem execution. A description of file retrieval procedures can be found in the Baseline subsystem section, File Creation and Retrieval. In addition, this subsystem requires retrieval of 3 additional modules from tape; these modules are listed in Table VI; they can be extracted from tape by following the same retrieval procedures as described for the Baseline subsystem modules.

Demographic Data

Airport Description Data Deck

Baseline Noise Impact Summary Report

The demographic data required by the NRS subsystem is identical to the data required for the execution of the Baseline subsystem. The user is referred to Appendix A for demographic file retrieval procedures. Additionally, the same Airport Description Data Deck is required by the NRS subsystem, as was required by the Baseline subsystem. If not online, the file must be retrieved from tape. Finally, the Noise Impact Summary Report, saved by the Baseline subsystem as an indirect access file, must be online.

TABLE VI.-NOISE REDUCTION SIMULATION MODULES

<u>FILE NAME</u>	<u>CLUSTER</u>	<u>FUNCTION</u>
NOIRD1A	CPFS	CCL Generator
NOIRD2A	CPFS	INM Database Modifier
NRSRPTA	CPFS	Plot/Report Generator

4.2.1.2 Airport Auxiliary File

Airport auxiliary file: The Airport Auxiliary File, as used by the Baseline subsystem, must be retrieved and modified for use by the Noise Reduction Simulation subsystem. As a result of a Baseline execution, 2 additional card images are added to this file. This information is utilized by the N.R.S. subsystem. Additionally, lines corresponding to card images 1,2, and 3 must be filled in with information, as described in Table VII. Card images 12 and 13 are created during execution of the baseline subsystem; the user is not responsible for providing the information, but must use the copy of the Airport Auxiliary File that results after processing with the baseline subsystem.

TABLE VII.-AIRPORT AUXILIARY FILE FORMAT

NOISE REDUCTION SIMULATION SUBSYSTEM

<u>CARD(S)</u>	<u>DATA</u>	<u>COLUMN(S)</u>	<u>FORMAT</u>
1	Delivery information	1-20	2A10
	User Number	21-27	A7
	Charge Number	29-34	A6
2	Reel Identifier	1-6	A6
	Backup Reel Identifier	8-13	A6
3	F.A.A. Identifier	1-3	A3
4-6	Blank		
7-11	Format - See TABLE III		
12	Plot Scale Factor	1-10	F10.5
13	Baseline Population Values	1-72	9I8

4.2.2 File-Naming Conventions

File-Naming Conventions: The responsibility of using appropriate file names, in accordance with set naming conventions, is assumed by the Noise Reduction Simulation software. The user need only be aware of the naming conventions that are employed, for proper file identification after program execution. As with the Baseline subsystem, the unique F.A.A. airport identifier is utilized as the first 3 characters in the 6-character file name; characters 4 and 5 are used to identify a specific run associated with the NRS subsystem. Character 6 is used, as with the Baseline mode, to distinguish between files generated by the processing of a specific Airport Description Data Deck with the modules of the baseline subsystem. The user is referred to Table IV, Baseline subsystem section, for a detailed file description associated with character 6. Table VIII illustrates the NRS file naming conventions utilized, with the Airport Description Data Deck used as the sample file.

TABLE VIII.--NOISE REDUCTION SIMULATION FILE NAMING CONVENTIONS

<u>FILE NAME</u>	<u>FILE IDENTIFICATION</u>
XXX0A1	2 dB Database Reduction
XXX0B1	4 dB Database Reduction
XXX0C1	6 dB Database Reduction
XXX0D1	8 dB Database Reduction
XXX0E1	10 dB Database Reduction
XXX0F1	-2 dB Database Reduction
XXX0G1	-4 dB Database Reduction

XXX = Unique Federal Aviation Administration Identifier

4.2.3 CYBER Control Language

CYBER Control Language.- The CYBER Control Language required to execute the Noise Reduction Simulation subsystem is illustrated by Figures 9 and 10. The submit file to initiate execution of the 7 parallel runs (Figure 9), must be submitted only after a successful execution of the baseline subsystem (Figure 4). The sample submit files contain editing notes to aid the user in file creation. The editing notes in Figure 10 indicate that a value must be provided for register 1 (R1). This register should be set to a value that accounts for the Baseline run, as well as all successful NRS subsystem runs. Typically R1 would be set to the value of 8.

```
NOIJOB1,T100,CM150000.                DELIVER INFO
\USER,....
CHARGE,.....,LRC.
GET,NOIRD1A,TAPE1=XXX,TAPE2=XXX001.
NOIRD1A,,,TAPE1,TAPE2.
EXIT.
```

EDITING NOTES:
- REPLACE XXX WITH F.A.A. IDENTIFIERS

Figure 9.-Submit file for Noise Reduction Simulation CCL Generation job.

```
NOIJOB2,T100,CM100000.                DELIVERY INFO
USER,....
CHARGE,.....,LRC.
SET(R1=8)
GET,NRSRPTA,XXXR.
NRSRPTA,,,XXXR,TAPE6,TAPE7.
REWIND,SAVPLT.
PLOT.CALPOST,11(FSH=20.0,FSV=11.0)
EXIT.
```

EDITING NOTES:
- REPLACE XXX WITH F.A.A. IDENTIFIER
- INSERT APPROPRIATE INTEGER VALUE FOR REGISTER SETTING

Figure 10.-Submit file for Noise Reduction Simulation Plot/Report job.

4.2.4 Sample Subsystem Results

Sample subsystem results.- Noise Reduction Simulation subsystem results consist of a plot vector file with 2 frames. The first frame, illustrated by Figure 11, represents the tabulated results of the source noise reduction, and the associated noise impact index. The second frame, illustrated by Figure 12, contains a graphical display of the noise impact index versus the source noise reduction.

EFFECT OF SOURCE NOISE REDUCTION

AIRPORT: "REPRESENTATIVE MIDWESTERN AIRPORT"

SOURCE NOISE REDUCTION	NOISE IMPACT INDEX
-4 DB	1.399
-2 DB	.963
0 DB	.634
2 DB	.409
4 DB	.243
6 DB	.149
8 DB	.109
10 DB	.061

Figure 11 - Tabulated results of the source noise reduction

"REPRESENTATIVE MIDWESTERN AIRPORT"

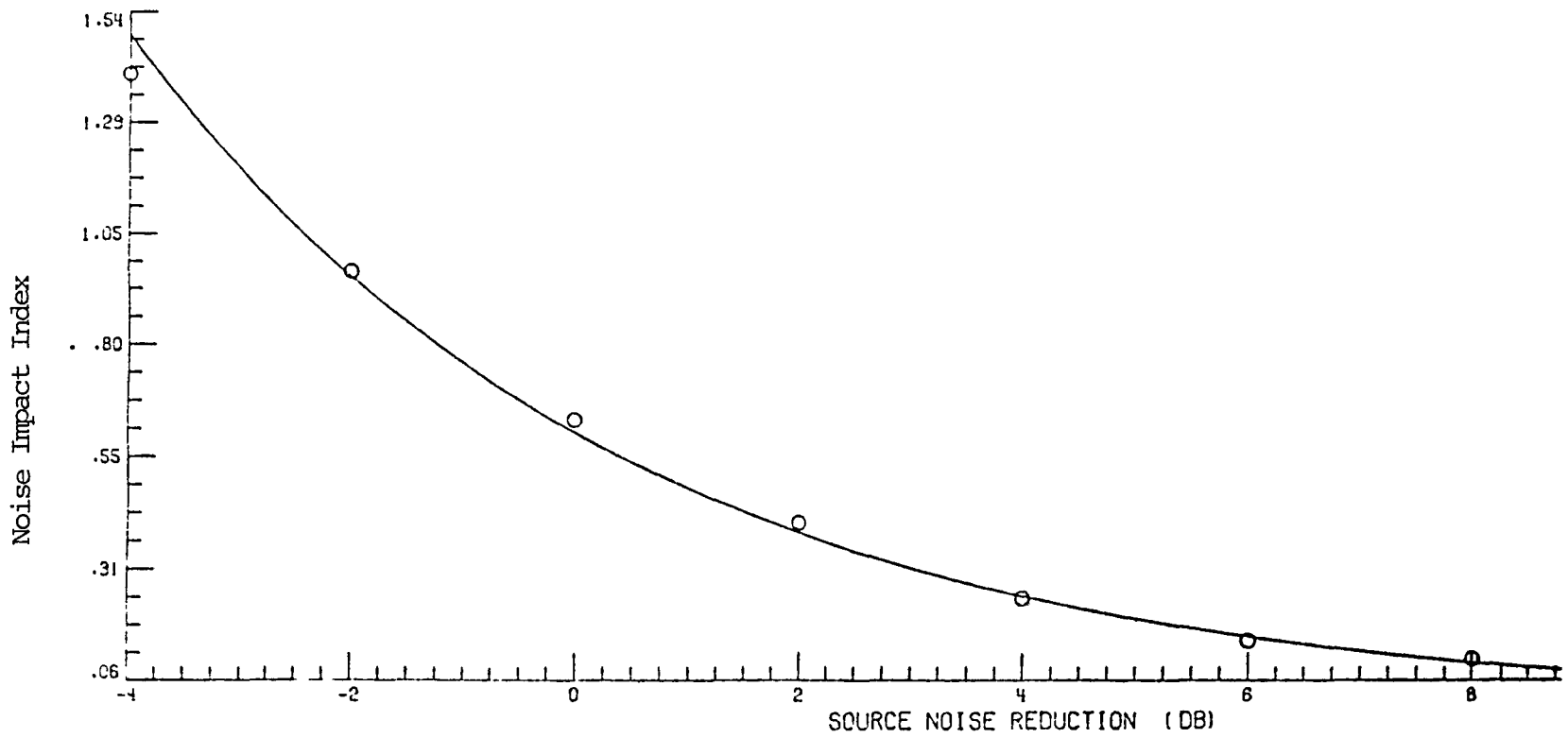

4-21

Figure 12 - Noise impact of source noise reduction

4.2.5 Case Runner's Checklist

Case Runner's Case.- Case running can be facilitated through the use of the checklist provided in Figure 13. It is recommended that the case runner utilize a copy of the checklist to ensure that the subsystem execution steps are accomplished in the appropriate sequences.

- _____ Execute Baseline subsystem

- _____ Modify Airport Auxiliary File

- _____ Extract all program modules, INM database, and ALAMO procedure file from tape, if not online

- _____ Set up demographic data

- _____ Submit CCL illustrated by Figure 9, upon completion of Baseline subsystem execution

- _____ Submit CCL illustrated by Figure 10, upon completion of execution of the 7 parallel N.R.S. subsystem runs

- _____ List labels from 2 tapes (use LISTLB statement)

- _____ Perform file management (purge unnecessary files)

Figure 13.-Case runner's checklist for Noise Reduction Simulation.

NOTES AND COMMENTS

TRACK ANALYSIS SUBSYSTEM

5.0 TRACK ANALYSIS SUBSYSTEM

The Track Analysis subsystem is designed to evaluate airport ground tracks, in order to obtain a visual representation of the track. Additionally, the evaluation yields a report that presents, for each ground track, the associated number of people overflowed when the track is utilized. A ground track, the representation of a flight path's projection on the ground, is specified in the Airport Description Data Deck as one or more straight or curved segments. Within the Track Analysis subsystem, the original track descriptions are converted to a series of xy-coordinates, expressed in half-mile units. Each track is modeled from the runway endpoint to the edge of the airport community. In addition to being plotted, these track coordinates are associated with specific population values in the airport community.

Central to the understanding of the Track Analysis subsystem is the notion of the airport community population grid. This grid, a 41 x 41 matrix of population values, is generated through the use of the SITE II demographics system. The airport community is subdivided into 1681 squares, each 1/2 mile by 1/2 mile; the center of the grid is the airport centroid, the geometric center of the runway configuration. The value of each node in the grid is equivalent to the population value contained in an area, 1/2 mile on a side, surrounding the node.

Input to the Track Analysis subsystem is the Airport Description Data Deck and the Airport Auxiliary File. Output produced by the Track Analysis subsystem consists of the plot of the airport ground tracks, as well as a report listing the population values associated with each track.

Subsystem Architecture

5.1 Subsystem Architecture

The Track Analysis subsystem uses the following software, executed in order of presentation: the SITE II Input Generator, the SITE II Demographics system, the Track Converter, the Track Plot Generator, and the Track Population Report Generator. A block diagram of this subsystem is illustrated by Figure 14. Module input/output specifications can be found in TABLE IX.

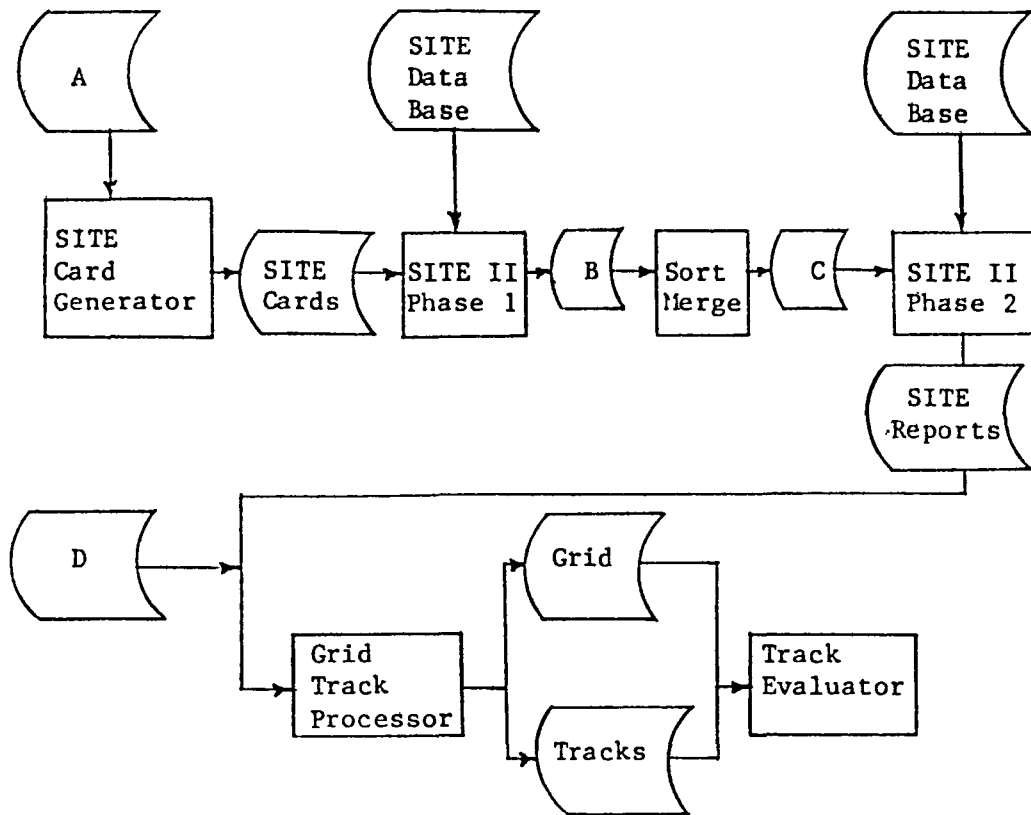

Legend:
 A - Airport Auxiliary File
 B - Selected Records
 C - Sorted Records
 D - Airport Description Data Deck

Figure 14.-Block diagram of Track Analysis Subsystem.

TABLE IX.-TRACK ANALYSIS MODULE SPECIFICATIONS

SITE II INPUT GENERATOR

NAME : INSITEA
FUNCTION : Generation of SITE Input Card Images
INPUT : Airport Auxiliary File (TAPE1/XXX)
OUTPUT : SITE Input (TAPE2)
SCRATCH : None

TRACK CONVERTER

NAME : INMXYA
FUNCTION : Track Conversion; Grid Generation
INPUT : Airport Description Data Deck (TAPE4/XXX001)
SITE Summary Reports (TAPE7/XXXSUM)
SCRATCH : TAPE3
TAPE5
TAPE6

TRACK PLOT GENERATOR

NAME : SMOOTHA
FUNCTION : Graphical Representation of Tracks
INPUT : Track Coordinates (TAPE2)
Airport Auxiliary File (TAPE3/XXX)
Airport Description Data Deck (TAPE5/XXX001)
OUTPUT : Plot Vector File
Track Coordinates-Mile Units (TAPE6)
SCRATCH : None

TRACK POPULATION REPORT GENERATOR

NAME : PEOPLEA
FUNCTION : Track Population Analysis
INPUT : Track Coordinates (TRACKS)
Airport Auxiliary File (IDFILE/XXX)
Grid Population File (POPFIL/XXXGRID)
OUTPUT : Line Printer Report
SCRATCH : None

5.1.1 SITE II Input Generator

SITE II Input Generator.- The SITE II Input Generator produces the card images, in accordance with the SITE II specifications, that are required to describe the airport community as a series of polygons; each polygon is a square, 1/2 mile on a side; the squares are described, starting in the northwest corner of the airport community, proceeding east in 1/2 mile increments, until 41 squares have been described; a displacement of 1/2 mile to the south is then made, repositioning is made to the western-most position, and another 41 squares are then described. This pattern is repeated until 41 rows of 41 squares have been described. The latitude and longitude of the airport centroid is the reference point for all polygon descriptions. The user is referred to the SITE II User's Manual for details concerning polygonal area descriptions and report formats. Each set of SITE II input cards requests output in the form of SITE II Summary Reports; these reports, when generated, contain the population found within the polygon described. Input to the SITE II Input Generator is the Airport Auxiliary File. Output from the module are the SITE II card images required to execute the SITE II system in order to produce 1681 Summary Reports, one for each square in the airport community.

5.1.2 SITE II Demographics System

SITE II Demographics System.- The SITE II Demographics System is a set of modules that queries a census database, and extracts specific demographic variables, in report form, pertinent to the area under study. In the Track Analysis subsystem, SITE II is used to generate SITE II Summary Reports, containing population information for a geometrically described area of interest. Input to the SITE II system are card images, in SITE II-specific format, containing a latitude, longitude, and a polygonal area expressed as a series of displacement values from the given latitude and longitude. Output from the SITE II system is a series of Summary Reports, one for each polygon, containing the number of people living within the described area.

5.1.3 Track Converter

Track Converter.- Within the Track Analysis subsystem, the Track Converter is a dual purpose program that accomplishes the following: (1) the processing of the SITE II Summary Reports, creating a file of grid population values and (2) the analysis of the Airport Description Data Deck, converting the track descriptions from a series of straight and curved segments, to a series of xy-coordinates. The coordinates are expressed as integer values, in 1/2 mile units; they describe the track from the node closest to the runway endpoint, to a node on the edge of the airport community population grid. Input to the Track Converter is the Airport Description Data Deck, and the SITE II Summary Reports. Output produced is a multi-file file, containing the grid population data, followed by an end-of-file mark, which in turn is followed by the file of track coordinates.

5.1.4 Track Plot Generator

Track Plot Generator.- The Track Plot Generator produces a plot vector file that is a representation of the ground track coordinates. In addition to drawing the tracks, the Track Plot Generator labels the output with the airport F.A.A. identifier and plots airport runways. Input to the Track Plot Generator is the Airport Auxiliary File, the Airport Description Data Deck, and a file of track coordinates. Output produced by the module is a plot vector file containing the track representations.

5.1.5 Track Population Report Generator

Track Population Report Generator.- The Track Population Report Generator processes the file of track coordinates, and associates each point on the track with a population value from the airport community population grid. The associated population values are summed for each track, and a report is produced with an entry for each track; the entry contains the track identifier, as well as the population associated with that track. Additionally, the report is labeled with the F.A.A. identifier for the airport under study. Input to the Track Population Report Generator is the Airport Auxiliary File, a file of track coordinates, and the airport community population grid values. Output from the module is the report, in printer listing format, for the ground tracks under evaluation.

Subsystem Usage

5.2 Subsystem Usage

Subsystem Usage.- To execute the Track Analysis subsystem, the user must accomplish the following steps:

1. File creation and retrieval
2. Preliminary processing
3. Submission of appropriate CCL to derive subsystem execution

Descriptions of these procedures follow; additionally, file-naming conventions are described, and sample subsystem results and a case runner's checklist are provided.

5.2.1 File Creation and Retrieval

File creation and retrieval.— The four following categories of files must be retrieved or modified for a Track Analysis subsystem run:

1. program modules and execution procedures
2. SITE II demographic data
3. Airport Description Data Deck
4. Airport Auxiliary File

Files in categories 1 and 2 reside on tape, and reference to retrieval procedures are given below. The Airport Description Data Deck, and the Airport Auxiliary File, must be created or modified as described below.

5.2.1.1 Program Modules

Program modules: All program modules listed in TABLE X must be brought online prior to Track Analysis subsystem execution. These modules exist on magnetic tapes, reel number NN0120; file retrieval procedures can be found in the Baseline subsystem section under File Creation and Retrieval.

TABLE X.-TRACK ANALYSIS MODULES

<u>FILE NAME</u>	<u>CLUSTER</u>	<u>FUNCTION</u>
A2	CPFS	ALAMO Procedure File
INMXYA	CPFS	Track Converter
INSITEA	CPFS	SITE II Input Generator
PEOPLEA	CPFS	Track Population Report Generator
PH1A	CPFS	SITE II-Phase 1
PH2A	CPFS	SITE II-Phase 2
SET	CPFS	SITE II Procedure File
SMOOTHA	CPFS	Track Plot Generator
SORTFL	CPFS	SORT/MERGE Directives

5.2.1.2 SITE II Demographic Data
Airport Description Data Deck

SITE II demographic data: The demographic data required by the Track Analysis subsystem is identical to the data required for execution of the Baseline subsystem. The user is referred to Appendix A for demographic file retrieval procedures. The Airport Description Data Deck, as required by the Baseline subsystem, is also required by the Track Analysis subsystem. If the user has executed the Baseline subsystem, the Airport Description Data Deck is available on the tape created by that subsystem. Otherwise, the file must be constructed. The user is referred to the description of the Airport Description Data Deck in the Baseline subsystem section for file specification.

5.2.1.3 Airport Auxiliary File

Airport auxiliary file: The Airport Auxiliary File, required by the Baseline subsystem, is also required by the Track Analysis subsystem. If the Baseline subsystem has been executed, the user retrieves the Airport Auxiliary File from tape and makes the required modifications to be compatible with the requirements of the Track Analysis subsystem. Otherwise, the user must construct the file. TABLE XI contains the file entries, with formatting specifications, that are required by the Track Analysis subsystem.

TABLE XI.-AIRPORT AUXILIARY FILE FORMAT
TRACK ANALYSIS SUBSYSTEM

<u>CARD(S)</u>	<u>DATA</u>	<u>COLUMN(S)</u>	<u>FORMAT</u>
1-2			
3	F.A.A. Identifier	1-3	A3
4-6			
7	Latitude		8A1
	Degrees	1-2	
	Minutes	4-5	
	Seconds	7-8	
	Longitude		9A1
	Degrees	11-13	
	Minutes	15-16	
	Seconds	18-19	
8-9			
10	Airport Name	1-24	24A1
11			

5.2.2 File-Naming Conventions

File-Naming conventions.- The responsibilities of using appropriate file names, in accordance with set naming conventions, is assumed partially by the user, and partially by the Track Analysis subsystem. TABLE XII illustrates the file-naming conventions used. The user must provide the Airport Auxiliary File, and save it as an indirect access file under the file name XXX, where XXX is the 3-character string representing the F.A.A. identifier for the airport under study. Appendix C contains a partial list of F.A.A. identifiers. The user must also provide the Airport Description Data Deck, saved under the file name of XXX001. After subsystem execution, 2 new files will be created and written to tape. File XXXSUM is the file of SITE II Summary Reports, generated in order to develop the airport community population grid. File XXXGRID is also created, stored on tape, and additionally saved as an indirect access file. XXXGRID is a multi-file file; the first set of data consists of the population values for the airport community population grid. The second file on XXXGRID consists of the xy-coordinates of the airport ground track.

TABLE XII.-TRACK ANALYSIS NAMING CONVENTIONS

<u>FILE NAME</u>	<u>FILE IDENTIFICATION</u>
XXX	Airport Auxiliary File
XXX001	Airport Description Data Deck
XXXGRID	Population Grid/Track Coordinates
XXXSUM	SITE II Summary Reports

XXX=Unique Federal Aviation Administration Identifier

Preliminary Processing

If the user is initiating ALAMO case running with the Track Analysis subsystem, and the Baseline subsystem has not been executed, it is necessary to perform tape initialization procedures, as described by the Baseline subsystem section under tape initialization. Any subsequent use of the tapes must not include initialization procedures. Reinitializing of the tapes causes all information previously written to tape to be lost.

5.2.3 CYBER Control Language

CYBER control language. The CYBER Control Language (CCL) required to execute the Track Analysis subsystem is illustrated by Figure 15. The Figure includes editing notes to aid the user in submit file creation. The CCL required for Track Analysis subsystem execution is primarily contained in the multi-procedure file, A2; Appendix B contains a listing of statements found in this file. The user is referred to the NOS User's Guide for an explanation of the control statements involved.

```
TRKJOB,T1000,CM150000. DELIVERY INFO
USER,....
CHARGE,.....,LRC.
BEGIN,G1,A2,XXX,XXXSUM,XXXGRID,XXX001.
VSN(TAPE51=NYYYYYY,TAPE52=NZZZZZ)
BEGIN,C1,A2,XXXSUM,XXXGRID,TAPE51.
EXIT.
CLEAR.
ATTACH,TEMP=XXXSUM/NA.
COPYEI,TEMP,XXXSUM.
REWIND,XXXSUM.
GET,XXXGRID/NA.
RETURN,TAPE51.
VSN(TAPE51=NYYYYYY,TAPE52=NZZZZZ)
BEGIN,C1,A2,XXXSUM,XXXGRID,TAPE52.
EXIT.
```

EDITING NOTES:

- INSERT ACTUAL REEL NUMBERS IN VSN STATEMENT
- REPLACE XXX WITH F.A.A. IDENTIFIER

Figure 15.-Submit file for Track Analysis job.

Sample Subsystem Results

Track Analysis subsystem results consist of a plot, illustrated by Figure 16, and a report, illustrated by Figure 17. The plot contains a representation of the airport ground tracks, runways, and the appropriate F.A.A. identifier. The report contains the population values associated with each track, indicating the number of people overflow when the specific track is selected for use.

XXX

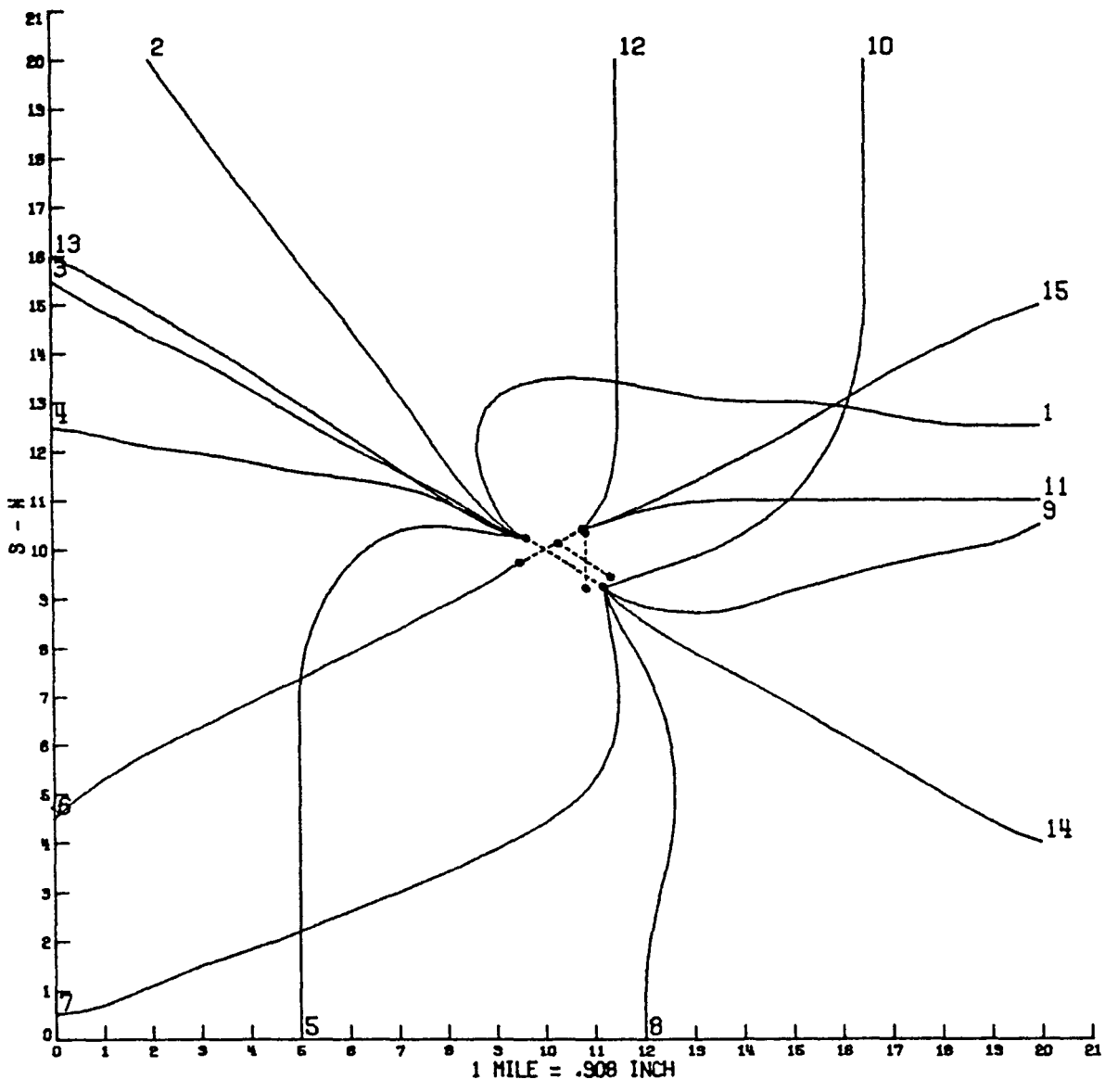

Figure 16. - Plot resulting from Track Analysis subsystem execution.

5.2.4 Case Runner's Checklist

Case runner's checklist.- Case running can be facilitated by the use of the checklist provided in Figure 18. It is recommended that the case runner utilize a copy of the checklist to ensure that the subsystem execution steps are accomplished in the appropriate sequence.

- _____ Create/obtain Airport Description Data Deck

- Create/modify Airport Auxiliary File
 - Airport Latitude :
 - Airport Longitude :
 - Airport Name :
 - F.A.A. Identifier :

- Extract required modules and procedure file from tape

- _____ Request and initialize tapes, if required
 - Reel 1 : _____
 - Reel 2 : _____

- _____ Set up SITE II database files

- Create and submit CCL to drive Track Analysis Subsystem execution

- _____ List labels on Reel 1 and Reel 2 (use LISTLB statement)

- _____ Perform file management (purge unnecessary files)

Figure 18.-Case runner's checklist for Track Analysis.

APPENDIX A

SITE II FILE PROCEDURES

The SITE II Demographics System is composed of two SITE II program modules, and the SITE II database. Due to its large size, the SITE II database is maintained on tape; pertinent sections of the database must be retrieved prior to any ALAMO subsystem execution. The custom installation of SITE II at LaRC allows for census data representative of exactly 3 states to be brought online at any given time. The user can accomplish a SITE II file retrieval by submitting, to the R or T machine, an appropriately-edited copy of the file illustrated by Figure 19; editing requirements are noted on the figure. The sample submit file is appropriately edited to retrieve census data for Illinois, Kentucky, and Missouri. This submit file invokes procedure file SET, in order to complete SITE II file retrieval. This procedure file is illustrated by Figure 20; it should be retrieved from tape using file access methods explained in the File Creation and Retrieval section, and stored on the CPFS cluster. The user is required to specify, in the submit file, state abbreviations and integer codes for the 3 states selected. The submit file, illustrated by Figure 19, contains editing notes to assist the case runner in the proper placement of the state integer codes and character abbreviations. A listing of the state integer codes and abbreviations is provided in TABLE XIII. Six files, residing on the WFS cluster, result from a successful execution of the

submit file. The resultant files are identified as MNF1, MNF2, MNF3, NSF1, NSF2, and NSF3.

Care should be taken, when selecting states, to include any bordering state that might be within a given airport community. For example, to include complete census data for National Airport, Washington, D.C., census data for the District of Columbia, Maryland, and Virginia must be retrieved. If a single state is sufficient to incorporate an entire airport community, then the additional states chosen should be states containing airports of interest for subsequent case studies.

```
SUBFIL,T100,CM100000. DELIVERY INFO
USER,...
CHARGE,.....,LRC.
GET,SET.
BEGIN,SETUP,SET,17,21,29,IL,KY,MO,1,0.
EXIT.
```

EDITING NOTES:

- REPLACE INTEGER CODES 17, 21, AND 29 WITH THE APPROPRIATE INTEGER CODES FOR THE STATES OF INTEREST
- REPLACE CHARACTER CODES IL, KY, AND MO WITH THE APPROPRIATE CHARACTER CODES FOR THE STATES OF INTEREST

Figure A1.-Submit file for SITE II file retrieval.

```

.PROC, SETUP, A, B, C, D, E, F, G, H.
BEGIN, T, SET, A, A, ND0775, ND1062, D, MNF1.
BEGIN, T, SET, A, B, ND0775, ND1062, E, MNF2.
BEGIN, T, SET, B, C, ND0775, ND1062, F, MNF3.
RETURN, TAPE1, MNF1, MNF2, MNF3.
IFE, (G.NE.0), LABELA.
VSN, TAPE2=ND0773.
BEGIN, BT, SET, BLKGRP, D, NSF1.
BEGIN, BT, SET, BLKGRP, E, NSF2.
BEGIN, BT, SET, BLKGRP, F, NSF3.
SKIP(LABELB)
ENDIF, LABELA.
VSN, TAPE2=ND0938.
BEGIN, BT, SET, TRACKS, D, NSF1.
BEGIN, BT, SET, TRACKS, E, NSF2.
BEGIN, BT, SET, TRACKS, F, NSF3.
ENDIF, LABELB.
RETURN, TAPE2.
IFE, (H.EQ.1), LABELC.
VSN, TAPE3=ND0753.
LABEL, TAPE3, PO=R, SI=ZIPCDS, FI=ZIPALL.
COPYBF, TAPE3, ZIF1.
REPLACE, ZIF1.
ENDIF, LABELC.
REVERT. MYCCL SETUP
.PROC, T, A, B, T1, T2, C, FF.
PURGE, FF/NA, ST=LPF.
DEFINE, FF.
IFE, (A.LE.28.AND.B.LE.28), LABELA.
LABEL, TAPE1, PO=R, VSN=T1, SI=MN1, FI=C.
SKIP, LABELD.
ENDIF, LABELA.
IFE, (A.GT.28.AND.B.GT.28), LABELB.
LABEL, TAPE1, PO=R, VSN=T2, SI=MN2, FI=C.
SKIP, LABELD.
ENDIF, LABELB.
RETURN, TAPE1.
IFE, (B.GT.28), LABELC.
LABEL, TAPE1, PO=R, VSN=T2, SI=MN2, FI=C.
SKIP, LABELD.
ENDIF, LABELC.
LABEL, TAPE1, PO=R, VSN=T1, SI=MN1, FI=C.
ENDIF, LABELD.
COPYBF, TAPE1, FF.
RETURN, FF.
REVERT. MYCCL T
.PROC, BT, SID, X, MN1.
PURGE, MN1/NA, ST=LPF.
DEFINE, MN1.
LABEL, TAPE2, SI=SID, FI=X, PO=R.
COPYBF, TAPE2, MN1.
RETURN, MN1.
REVERT. MYCCL BT

```

Figure A2. - SITE II multi-procedure file.

TABLE XIII. SITE II STATE CODES AND ABBREVIATIONS

<u>STATE NAMES</u>	<u>ABBREVIATION</u>	<u>CODE</u>
ALABAMA	AL	01
ALASKA	AK	02
ARIZONA	AZ	04
ARKANSAS	AR	05
CALIFORNIA	CA	06
COLORADO	CO	08
CONNECTICUT	CT	09
DELAWARE	DE	10
DISTRICT OF COLUMBIA	DC	11
FLORIDA	FL	12
GEORGIA	GA	13
HAWAII	HI	15
IDAHO	ID	16
ILLINOIS	IL	17
INDIANA	IN	18
IOWA	IA	19
KANSAS	KS	20
KENTUCKY	KY	21
LOUISIANA	LA	22
MAINE	ME	23
MARYLAND	MA	25
MICHIGAN	MI	26
MINNESOTA	MN	27

TABLE XIII. SITE II STATE CODES AND ABBREVIATIONS
(continued)

<u>STATE NAMES</u>	<u>ABBREVIATION</u>	<u>CODES</u>
MISSISSIPPI	MS	28
MISSOURI	MO	29
MONTANA	MT	30
NEBRASKA	NE	31
NEVADA	NV	32
NEW HAMPSHIRE	NH	33
NEW JERSEY	NJ	34
NEW MEXICO	NM	35
NEW YORK	NY	36
NORTH CAROLINA	NC	37
NORTH DAKOTA	ND	38
OHIO	OH	39
OKLAHOMA	OK	40
OREGON	OR	41
PENNSYLVANIA	PA	42
RHODE ISLAND	RI	44
SOUTH CAROLINA	SC	45
SOUTH DAKOTA	SD	46
TENNESSEE	TN	47
TEXAS	TX	48
UTAH	UT	49
VERMONT	VT	50

TABLE XIII. SITE II STATE CODES AND ABBREVIATIONS
(continued)

<u>STATE NAMES</u>	<u>ABBREVIATION</u>	<u>CODES</u>
VIRGINIA	VA	51
WASHINGTON	WA	52
WEST VIRGINIA	WV	54
WISCONSIN	WI	55
WYOMING	WY	56

NOTES AND COMMENTS

APPENDIX B

ALAMO SYSTEM MULTIPROCEDURE FILE

Figure 21, the ALAMO multi-procedure file A2, contains the CYBER Control Language invoked by all 3 subsystems. The user is referred to the NOS User's Guide for a detailed explanation of each statement.

```

.PROC,A1,A,B,C,D,E,F,G,H,J,K.
*****
* FILE A2 CONTAINS THE 5 FOLLOWING PROCEDURE FILES:
*   A1 : DRIVER FOR A COMPLETE ALAMO RUN
*   B1 : EXECUTES PHASE 2 OF ALAMO
*   C1 : WRITES FILES PRODUCED BY ALAMO RUN TO
*         TAPE (TAPES1 FOR SUCCESSFUL RUN, TAPES2
*         FOR RUN WITH ERRORS)
*   D1 : INITIALIZES TAPES USED IN ALAMO RUN
*   G1 : GENERATES POPULATION GRID AND STANDARD
*         TRACKS
*****
* A1 PROCEDURE PARAMETER IDENTIFICATION:
*   A : INM INPUT CASE
*   B : LISTABLE INM OUTPUT
*   C : INM OUTPUT - CONTOUR POINTS (PHASE 2 INPUT)
*   D : PHASE 1 OUTPUT (SITE II INPUT)
*   E : SAVPLT FILE - OUTPUT FROM PHASE 1
*   F : SITE II OUTPUT (PARTIAL)
*   G : SITE II OUTPUT (COMPLETE) - INPUT FOR PHASE 2
*   H : 10TH PAGE ALAMO REPORT (BASELINE CASE)
*   J : 10TH PAGE ALAMO REPORT (COUNTERMEASURE CASE)
*   K : ALAMO AUXILIARY FILE (INPUT FOR PHASES 1 AND 2)
*****
*
* IF R3=1, NOISE REDUCTION SIMULATION RUN IS IN PROGRESS;
* A MODIFIED VERSION OF INM DATABASE ALREADY EXISTS
*
ATTACH,CONTORA.
IFE,(R3.NE.1),LABEL1.
ATTACH,DATABIN.
COPYEI,DATABIN,TAPE7.
REWIND,TAPE7.
RETURN,DATABIN.
ENDIF,LABEL1.
GET,A.
*
* EXECUTE THE INM MODULE OF ALAMO
*
CONTORA,A,B.
SEND,B,DC=LP.
RETURN,CONTORA.
REWIND,TAPE2.
COPYEI,TAPE2,C.
SKIP(LABELA)
EXIT.
SKIP(LABEL99)
ENDIF(LABELA)
RETURN,TAPES,TAPE6,TAPE2,TAPE8.
RETURN,TAPES9,TAPE3,TAPE7.
*
* EXECUTE PHASE 1
*
REWIND,C.
GET,ALPHS1A,K.
ALPHS1A,C,,,,,K.
MAP,OFF.
IFE,(R3.EQ.0),LABEL6.
REPLACE,K.
SET(R1G=R2)

```

Figure B1. - ALAMO system multi-procedure file.

```

ENDIF, LABEL6.
REWIND, TAPE1.
COPYEI, TAPE1, D.
REWIND, SAVPLT.
COPYEI, SAVPLT, E.
REWIND, SAVPLT.
PLOT.CALPOST, 11(XM=.7, YM=.7)
CONT.//BLANK PAPER BLACK BALLPOINT//
SKIP(LABELB)
EXIT.
DMP.
DMD(270000).
SKIP(LABEL99)
ENDIF(LABELB)
DISPLAY(R1)
DISPLAY(R2)
DISPLAY(R1G)
RETURN, TAPE5, TAPE6, TAPE1, TAPE2, TAPE4.
REWIND, D.
*
* EXECUTE SITE II
*
WHILE, (R1.NE.0), LABEL3.
ATTACH, TAPE21=NSF1.
ATTACH, TAPE22=NSF2.
ATTACH, TAPE23=NSF3.
GET, PH1A.
PH1A, D, F.
FILE, TAPE1, BT=I, RT=W, MRL=80.
FILE, TAPE2, BT=I, RT=W, MRL=80.
GET, SORTFL.
SORTMRG, I=SORTFL, O=F.
ATTACH, TAPE31=MNF1.
ATTACH, TAPE32=MNF2.
ATTACH, TAPE33=MNF3.
GET, PH2A.
PH2A, F.
REWIND, F.
COPYEI, F, G.
RETURN, TAPE1, TAPE2, TAPE3, TAPE4, TAPE21, TAPE22.
RETURN, TAPE23, TAPE31, TAPE32, TAPE33.
RETURN, F.
SET(R1=R1-1)
ENDW, LABEL3.
REWIND, G.
SKIP(LABELC)
EXIT.
DMP.
DMD(270000).
SKIP(LABEL99)
ENDIF(LABELC)
RETURN, PH1A, TAPE21, TAPE22, TAPE23.
RETURN, SORTFL, TAPE31, TAPE32, TAPE33, PH2A.
RETURN, TAPE5, TAPE6, TAPE1, TAPE2.
*
* BEGIN B1 TO EXECUTE PHASE 2 OF ALAMO RUN
*
BEGIN, B1, A2, G, H, J, K.
SKIP(LABELD)
EXIT.

```

Figure B1. - Continued.

```

EXIT.
DMP.
DMD(270000).
SKIP(LABEL99)
ENDIF(LABELD)
*
* WRITE ALAMO-PRODUCED FILES TO TAPES1 IF RUN IS
* SUCCESSFUL
*
REWIND,A,B,C,D,E,F,G,H,J,K.
REWIND,TAPE6.
BEGIN,C1,A2,A,B,TAPES1.
BEGIN,C1,A2,C,D,TAPES1.
BEGIN,C1,A2,E,G,TAPES1.
BEGIN,C1,A2,H,K,TAPES1.
BEGIN,C1,A2,TAPE6,K,TAPES1.
RETURN,TAPES1.
SKIP(LABELE)
ENDIF(LABEL99)
*
* SET R1G-99 TO INDICATE BASELINE PROBLEM; WRITE ALL
* FILES PRODUCED BY ALAMO TO TAPES2
*
SET(R1G-99)
REWIND,A,B,C,D,E,F,G,H,J,K.
REWIND,TAPE6.
BEGIN,C1,A2,A,B,TAPES2.
BEGIN,C1,A2,C,D,TAPES2.
BEGIN,C1,A2,E,F,TAPES2.
BEGIN,C1,A2,G,H,TAPES2.
BEGIN,C1,A2,TAPE6,K,TAPES2.
RETURN,TAPES2.
ENDIF(LABELE)
REVERT.MYCCCL

```

Figure B1. - Continued.

```

.PROC,B1,G,H,J,K.
*****
* B1 EXECUTES PHASE 2 OF ALAMO
*
* B1 PROCEDURE PARAMETER IDENTIFICATION:
*   G : SITE II REPORTS (PHASE 2 INPUT)
*   H : 10TH PAGE ALAMO REPORT (COUNTERMEASURE CASE)
*   J : 10TH PAGE ALAMO REPORT (BASELINE CASE)
*   K : ALAMO AUXILIARY FILE
*****
GET,AUREPTA.
GET,K.
REWIND,G.
PACK,G.
MAP,OFF.
AUREPTA,G,TAPES,,K,H.
REWIND,H,TAPES.
COPYEI,TAPES.
IFE,(R3.EQ.0),LABEL4.
REPLACE,G.
COPYEI,H,J.
REWIND,J.
SAVE,J.
REWIND,H,K,TAPES.
PACK,K.
REPLACE,K.
ELSE,LABEL4.
APPEND,J,H.
ENDIF,LABEL4.
REVERT.MYCL

```

Figure B1. - Continued.

```

.PROC,C1,A,B,Z.
*****
* C1 WRITES EXISTING FILES PRODUCED BY ALAMO TO TAPE
*
* C1 PROCEDURE PARAMETER IDENTIFICATION:
*   A : ALAMO-GENERATED FILE FOR TAPE
*   B : ALAMO-GENERATED FILE FOR TAPE
*   Z : TAPE REEL IDENTIFIER
*****
IFE,FILE(A,LO),LABELF.
REWIND,A.
LABEL(Z,PO=W,FR=Y,SI=ALAMO,FI=A,QN=9999).
COPYEI,A,Z.
ENDIF,LABELF.
IFE,FILE(B,LO),LABELG.
REWIND,B.
LABEL(Z,PO=W,FR=Y,SI=ALAMO,FI=B,QN=9999).
COPYEI,B,Z.
ENDIF,LABELG.
REVERT.MYCCL

```

Figure B1. - Continued.

```
.PROC,D1,K.  
* D1 INITIALIZES TAPES  
*  
* D1 PROCEDURE PARAMETER IDENTIFIERS:  
*   K : ALAMO AUXILIARY FILE  
*  
GET,K.  
LABEL(TAPES1,PO=W,FA=Y,SI=ALAMO,FI=INIT,GN=1,W).  
COPYEI,K,TAPES1.  
RETURN,TAPES1.  
REWIND,K.  
LABEL(TAPES2,PO=W,FA=Y,SI=ALAMO,FI=INIT,GN=1,W).  
COPYEI,K,TAPES2.  
RETURN,TAPES2,K.  
REVERT.MYCOL
```

Figure B1.- Continued.

.PROC,G1,A,B,CC,D.

```
*****
* G1 DEVELOPS GRID OF AIRPORT COMMUNITY.
* AND DEVELOPS STANDARD TRACKS
*
* G1 PROCEDURE PARAMETER IDENTIFICATION:
*   A : ALAMO AUXILIARY FILE
*   B : SITE II OUTPUT FILE (INPUT TO INMXYA)
*   CC: FILE CONTAINING GRID AND STANDARD
*       TRACKS
*   D : INM BASELINE INPUT CASE
*****
```

```
GET,INSITEA,A.
INSITEA,,,A,INSITEF.
COMMENT. JOB CONTAINS 1 ES-COUNT LOOP
RETURN,INSITEA.
REWIND,INSITEF.
DEFINE,B.
ATTACH,TAPE21=NSF1,TAPE22=NSF2,TAPE23=NSF3.
ATTACH,TAPE31=MNF1,TAPE32=MNF2,TAPE33=MNF3.
GET,PH1A,PH2A.
SET(R1=ES)
*
* GENERATE SITE II SUMMARY REPORTS FOR GRID
*
WHILE,(R1.GT.0),LABELB.
PH1A,INSITEF,B.
FILE,TAPE1,BT=I,RT=W,MRL=80.
FILE,TAPE2,BT=I,RT=W,MRL=80.
GET, SORTFL.
SORTMRG,I=SORTFL,O=B.
PH2A,B.
RETURN,TAPE1,TAPE2,TAPE3,TAPE4.
SET(R1=R1-1)
ENDW,LABELB.
FILE,TAPE1,RT=S,BT=C.
FILE,TAPE2,RT=Z,BT=C.
RETURN,PH1A,PH2A,TAPE21,TAPE22,TAPE23.
RETURN,TAPE31,TAPE32,TAPE33,TAPE1,TAPE2,TAPE3,TAPE4.
REWIND,B.
GET,INMXYA,D.
*
* PROCESS SUMMARY REPORTS AND GENERATE
* STANDARD TRACKS
*
INMXYA,D,TAPE6,CC,TAPE3,,TAPE5,,B.
SAVE,CC.
CLEAR.
GET,SMOOTH,PEOPLEA,CC,A,D.
SKIPF,CC,1.
COPYBF,CC,STD.
REWIND,CC,STD.
*
* PLOT STANDARD TRACKS; THEN GENERATE STANDARD
* TRACK REPORT
*
SMOOTH,D,TAPE6,,,STD,A.
REWIND,SAVPLT,A,STD.
PLOT.VERPOST
PEOPLEA,STD,CC,A,STDRPT.
```

```
ROUTE (STRPT, DC-LP).  
CLEAR.  
GET; CC.  
ATTACH, TEMP=B.  
COPYEI, TEMP, B.  
REWIND, B.  
RETURN; TEMP.  
REVERT.MYCL
```

Figure B1.- Concluded.

APPENDIX C

F.A.A. IDENTIFIERS

TABLE XIV provides the user with the following information for each airport entry: location, both city and state, airport name, and the 3-character unique F.A.A. identifier.

APPENDIX C

TABLE XIV. - AIRPORT LOCATION AND IDENTIFICATION

<u>CITY</u>	<u>STATE</u>	<u>AIRPORT NAME</u>	<u>F.A.A. ID</u>
ALLENTOWN	PA	ALLENTOWN-BETHLEHEM-EASTON	ABE
ABILENE	TX	ABILENE MUNI	ABI
ALBUQUERQUE	NM	ALBUQUERQUE INTL	ABQ
ABERDEEN	SD	ABERDEEN REGIONAL	ABR
ALBANY	GA	ALBANY-DOUGHERTY COUNTY	ABY
ARCATA/EUREKA/	CA	ARCATA	ACV
ATLANTIC CITY	NJ	NAFEC ATLANTIC CITY	ACY
KODIAK	AK	KODIAK	ADQ
AUGUSTA	GA	BUSH FIELD	AGS
KING SALMON	AK	KING SALMON	AKN
ALBANY	NY	ALBANY COUNTY	ALB
WATERLOO	IA	WATERLOO MUNI	ALO
AMARILLO	TX	AMARILLO INTERNATIONAL	AMA
ANCHORAGE	AK	ANCHORAGE INTL	ANC
ANIAK	AK	ANIAK	ANI
ALPENA	MI	HELPS COLLINS	APN
ATLANTA	GA	THE WILLIAM B HARTSFIELD ATLANTA INTL	ATL
APPLETON	WI	OUTAGAMIE COUNTY	ATW
WATERTOWN	SD	WATERTOWN MUNI	ATY
AUSTIN	TX	ROBERT MUELLER MUNI	AUS
ASHEVILLE	NC	ASHEVILLE MUNI	AVL
WILKES-BARRE/SCRANTON	PA	WILKES-BARRE/SCRANTON INTL	AVP
KALAMAZOO	MI	KALAMAZOO MUNI	AZO
WINDSOR LOCKS	CT	BRADLEY INTL	BDL
BETHEL	AK	BETHEL	BET
SCOTTSBLUFF	NE	SCOTTS BLUFF COUNTY	BFF
SEATTLE	WA	BOEING FIELD/KING COUNTY INTL	BFI
BINGHAMTON	NY	BROOME COUNTY	BGM
BANGOR	ME	BANGOR INTL	BGR
BIRMINGHAM	AL	BIRMINGHAM MUNI	BHM
BILLINGS	MT	BILLINGS LOGAN INTL	BIL
BISMARCK	ND	BISMARCK MUNI	BIS
CLEVELAND	OH	BURKE LAKEFRONT	BKL

APPENDIX C

<u>CITY</u>	<u>STATE</u>	<u>AIRPORT NAME</u>	<u>F.A.A. ID</u>
NASHVILLE	TN	NASHVILLE METROPOLITAN	BNA
BOISE	ID	BOISE AIR TERMINAL /GOWEN FLD/	BOI
BOSTON	MA	GENERAL EDWARD LAWRENCE LOGAN INTL	BOS
BEAUMONT/PORT ARTHUR	TX	JEFFERSON COUNTY	BPT
AGUADILLA	PR	BORINQUEN	BQN
BROWNSVILLE	TX	BROWNSVILLE INTL	BRO
BARROW	AK	WILEY POST-WILL ROGERS MEM	BRW
BUTTE	MT	BERT MOONEY	BTM
BATON ROUGE	LA	RYAN	BTR
BURLINGTON	VT	BURLINGTON INTL	BTV
BUFFALO	NY	GREATER BUFFALO INTL	BUF
BURBANK	CA	BURBANK-GLENDALE-PASADENA	BUR
BALTIMORE	MD	BALTIMORE-WASHINGTON INTL	BWI
BOZEMAN	MT	GALLATIN FLD	BZN
COLUMBIA	SC	COLUMBIA METROPOLITAN	CAE
AKRON	OH	AKRON-CANTON REGIONAL	CAK
CORDOVA	AK	CORDOVA-MILE 13	CDV
CHATTANOOGA	TN	LOVELL FIELD	CHA
CHARLOTTESVILLE	VA	CHARLOTTESVILLE-ALBEMARLE	CHO
CHARLESTON	SC	CHARLESTON INTERNATIONAL	CHS
CEDAR RAPIDS	IA	CEDAR RAPIDS MUNI	CID
SAULT STE MARIE	MI	CHIPPEWA COUNTY INTERNATIONAL	CIU
CLEVELAND	OH	CLEVELAND-HOPKINS INTL	CLE
CHARLOTTE	NC	DOUGLAS MUNI	CLT
COLUMBUS	OH	PORT COLUMBUS INTL	CMH
CHAMPAIGN/URBANA/	IL	UNIVERSITY OF ILLINOIS-WILLARD	CMI
HANCOCK	MI	HOUGHTON COUNTY MEMORIAL	CMX
COLORADO SPRINGS	CO	CITY OF COLORADO SPRINGS MUNI	COS
COLUMBIA	MO	COLUMBIA REGIONAL	COU
CASPER	WY	NATRONA COUNTY INTL	CPR
CORPUS CHRISTI	TX	CORPUS CHRISTI INTL	CRP
CHARLESTON	WV	KANAWHA	CRW
COLUMBUS	GA	COLUMBUS METROPOLITAN	CSG
COVINGTON/CINCINNATI, OH	KY	GREATER CINCINNATI INTL	CVG

APPENDIX C

<u>CITY</u>	<u>STATE</u>	<u>AIRPORT NAME</u>	<u>F.A.A. ID</u>
MOSINEE	WI	CENTRAL WISCONSIN	CWA
DAYTONA BEACH	FL	DAYTONA BEACH REGIONAL	DAB
DALLAS	TX	DALLAS LOVE FIELD	DAL
DAYTON	OH	JAMES M COX DAYTON INTERNATIONAL	DAY
DUBUQUE	IA	DUBUQUE MUNI	DBQ
WASHINGTON	DC	WASHINGTON NATIONAL	DCA
DECATUR	IL	DECATUR	DEC
DENVER	CO	STAPLETON INTL	DEN
DALLAS-FORT WORTH	TX	DALLAS-FORT WORTH REGIONAL	DFW
DOTHAN	AL	DOTHAN	DHN
DILLINGHAM	AK	DILLINGHAM	DLG
DULUTH	MN	DULUTH INTL	DLH
DURANGO	CO	DURANGO-LA PLATA COUNTY	DRO
DES MOINES	IA	DES MOINES MUNI	DSM
DETROIT	MI	DETROIT METROPOLITAN WAYNE COUNTY	DTW
EAU CLAIRE	WI	EAU CLAIRE COUNTY	EAU
ELKO	NV	ELKO MUNI-J.C. HARRIS FIELD	EKO
ELMIRA	NY	CHEMUNG COUNTY	ELM
EL PASO	TX	EL PASO INTL	ELP
ELY	NV	ELY ARPT /YELLAND FLD/	ELY
KENAI	AK	KENAI MUNI	ENA
ERIE	PA	ERIE INTL	ERI
ESCANABA	MI	DELTA COUNTY	ESC
ALEXANDRIA	LA	ESLER REGIONAL	ESF
EUGENE	OR	MAHLON SWEET FIELD	EUG
EVANSVILLE	IN	EVANSVILLE DRESS REGIONAL	EVV
NEWARK	NJ	NEWARK INTL	EWR
KEY WEST	FL	KEY WEST INTL	EYW
FAIRBANKS	AK	FAIRBANKS INTL	FAI
FARGO	ND	HECTOR FIELD	FAR
FRESNO	CA	FRESNO AIR TERMINAL	FAT
FAYETTEVILLE	NC	FAYETTEVILLE MUNI/GRANNIS FLD	FAY
KALISPELL	MT	GLACIER PARK INTL	FCA
FT LAUDERDALE	FL	FT LAUDERDALE-HOLLYWOOD INTL	FLL

APPENDIX C

<u>CITY</u>	<u>STATE</u>	<u>AIRPORT NAME</u>	<u>F.A.A. ID</u>
FLORENCE	SC	FLORENCE CITY-COUNTY	FLO
FT MYERS	FL	PAGE FIELD	FMY
FLINT	MI	BISHOP	FNT
FORT DODGE	IA	FORT DODGE MUNI	FOD
TOPEKA	KS	FORBES FIELD	FOE
SIOUX FALLS	SD	JOE FOSS FIELD	FSD
FORT SMITH	AR	FORT SMITH MUNI	FSM
FORT WAYNE	IN	FORT WAYNE MUNI/BAER FLD/	FWA
FAYETTEVILLE	AR	DRAKE FLD	FYV
GALENA	AK	GALENA	GAL
GRAND CANYON	AZ	GRAND CANYON NATIONAL PARK	GCN
SPOKANE	WA	SPOKANE INTL	GEG
GRAND FORKS	ND	GRAND FORKS INTL	GFK
GRAND JUNCTION	CO	WALKER FIELD	GJT
GREENVILLE	MS	GREENVILLE INTERNATIONAL	GLH
GAINESVILLE	FL	GAINESVILLE REGIONAL AIRPORT	GNV
GULFPORT	MS	GULFPORT-BILOXI RGNL	GPT
GREEN BAY	WI	AUSTIN-STRAUBEL FIELD	GRB
GRAND ISLAND	NE	HALL COUNTY REGIONAL	GRI
GRAND RAPIDS	MI	KENT COUNTY INTL	GRR
GREENSBORO	NC	GREENSBORO-HIGH POINT-WINSTON SALEM REGNL	GSO
GREER	SC	GREENVILLE-SPARTANBURG	GSP
GREAT FALLS	MT	GREAT FALLS INTL	GTF
COLUMBUS/W POINT/STARKVILL	MS	GOLDEN TRIANGLE REGIONAL	GTR
HIBBING	MN	CHISHOLM-HIBBING	HIB
HELENA	MT	HELENA	HLN
HONOLULU	HI	HONOLULU INTL	HNL
HOMER	AK	HOMER	HOM
HOUSTON	TX	WILLIAM P HOBBY	HOU
HARLINGEN	TX	HARLINGEN INDUSTRIAL AIRPARK	HRL
HUNTSVILLE	AL	HUNTSVILLE-MADISON CO JETPORT-CARL T JONES	HSV
HUNTINGTON	WV	TRI-STATE /WALKER-LONG FIELD/	HTS
WASHINGTON	DC	DULLES INTL	IAD
HOUSTON	TX	HOUSTON INTERCONTINENTAL	IAH

APPENDIX C

<u>CITY</u>	<u>STATE</u>	<u>AIRPORT NAME</u>	<u>F.A.A. ID</u>
WICHITA	KS	WICHITA MID-CONTINENT	ICT
IDAHO FALLS	ID	FANNING FIELD	IDA
WILMINGTON	NC	NEW HANOVER COUNTY	ILM
IRON MOUNTAIN/KINGSFORD	MI	FORD	IMT
INDIANAPOLIS	IN	INDIANAPOLES INTERNATIONAL	IND
INTERNATIONAL FALLS	MN	FALLS INTL	INL
WINSTON SALEM	NC	SMITH REYNOLDS	INT
KINSTON	NC	EASTERN RGNL JETPORT AT STALLINGS FLD	ISO
ISLIP	NY	LONG ISLAND MAC ARTHUR	ISP
ITHACA	NY	TOMPKINS COUNTY	ITH
HILO	HI	GENERAL LYMAN FIELD	ITO
JACKSON	MS	ALLEN C THOMPSON FIELD	JAN
JACKSONVILLE	FL	JACKSONVILLE INTL	JAX
NEW YORK	NY	JOHN F KENNEDY INTL	JFK
JOPLIN	MO	JOPLIN MUNI	JLN
JUNEAU	AK	JUNEAU INTL	JNU
KAILUA-KONA	HI	KE-AHOLE	KOA
ANDREAFSKY /ST MARYS/	AK	ST MARYS	KSM
KETCHIKAN	AK	KETCHIKAN INTL	KTN
LANSING	MI	CAPITAL CITY	LAN
LAS VEGAS	NV	MC CARRAN INTL	IAS
LAWTON	OK	LAWTON MUNI	LAW
LOS ANGELES	CA	LOS ANGELES INTL	LAX
LUBBOCK	TX	LUBBOCK INTL	LBB
NORTH PLATTE	NE	LEE BIRD FIELD	LBF
LAKE CHARLES	LA	LAKE CHARLES MUNI	LCH
LEXINGTON	KY	BLUE GRASS	LEX
LAFAYETTE	LA	LAFAYETTE REGIONAL	LFT
NEW YORK	NY	LA GUARDIA	LGA
LONG BEACH	CA	LONG BEACH /DAUGHERTY FIELD/	LGB
LIHUE	HI	LIHUE	LIH
LITTLE ROCK	AR	ADAMS FIELD	LIT
KLAMATH FALLS	OR	KINGSLEY FIELD	LMT
LINCOLN	NE	LINCOLN MUNI	LNK

APPENDIX C

<u>CITY</u>	<u>STATE</u>	<u>AIRPORT NAME</u>	<u>F.A.A. ID</u>
LAREDO	TX	LAREDO INTERNATIONAL	LRD
LA CROSSE	WI	LA CROSSE MUNI	LSE
LEWISBURG	WV	GREENBRIER VALLEY	LWB
LEWISTON	ID	LEWISTON-NEZ PERCE COUNTY	LWS
LYNCHBURG	VA	LYNCHBURG MUNI-PRESTON GLENN FIELD	LYH
MIDLAND	TX	MIDLAND REGIONAL	MAF
SAGINAW	MI	TRI CITY	MBS
MCGRATH	AK	MCGRATH	MCG
KANSAS CITY	MO	KANSAS CITY INTL	MCI
MACON	GA	LEWIS B. WILSON	MCN
ORLANDO	FL	ORLANDO INTERNATIONAL	MCO
MASON CITY	IA	MASON CITY MUNI	MCW
MIDDLETOWN	PA	HARRISBURG INTL ARPT-OLMSTED FLD	MDT
CHICAGO	IL	CHICAGO MIDWAY	MDW
MERIDIAN	MS	KEY FIELD	MEI
MEMPHIS	TN	MEMPHIS INTL	MEM
MC ALLEN	TX	MILLER INTL	MFE
MEDFORD	OR	MEDFORD-JACKSON COUNTY	MFR
MONTGOMERY	AL	DANNELLY FIELD	MGM
MANHATTAN	KS	MANHATTAN MUNI	MHK
MANCHESTER	NH	MANCHESTER ARPT/GRENIER INDUSTRIAL AIRPARK	MHT
MIAMI	FL	MIAMI INTL	MIA
KANSAS CITY	MO	KANSAS CITY DOWNTOWN	MKC
MILWAUKEE	WI	GENERAL MITCHELL FIELD	MKE
MUSKEGON	MI	MUSKEGON COUNTY	MKG
KAUNAKAKAI	HI	MOLOKAI	MKK
MELBOURNE	FL	MELBOURNE REGIONAL	MLB
MC ALESTER	OK	MC ALESTER MUNI	MLC
MOLINE	IL	QUAD-CITY	MLI
MONROE	LA	MONROE REGIONAL	MLU
MOBILE	AL	BATES FIELD	MOB
MINOT	ND	MINOT INTL	MOT
MARQUETTE	MI	MARQUETTE COUNTY	MQT
MONTEREY	CA	MONTEREY PENINSULA	MRY

APPENDIX C

<u>CITY</u>	<u>STATE</u>	<u>AIRPORT NAME</u>	<u>F.A.A. ID</u>
MUSCLE SHOALS	AL	MUSCLE SHOALS	MSL
MADISON	WI	DANE COUNTY REGIONAL/TRUAX FIELD	MSN
MISSOULA	MT	JOHNSON-BELL FIELD	MSO
MINNEAPOLIS	MN	MINNEAPOLIS-ST PAUL INTL/WOLD-CHAMBERLAIN/	MSP
NEW ORLEANS	LA	NEW ORLEANS INTL/MOISANT FLD/	MSY
MYRTLE BEACH	SC	MYRTLE BEACH AFB	MYR
JACKSONVILLE	NC	ALBERT J ELLIS	OAJ
OAKLAND	CA	METROPOLITAN OAKLAND INTL	OAK
KAHULUI	HI	KAHULUI	OGG
OKLAHOMA CITY	OK	WILL ROGERS WORLD	OKC
OMAHA	NE	EPPLEY AIRFIELD	OMA
NOME	AK	NOME	OME
ONTARIO	CA	ONTARIO INTL	ONT
CHICAGO	IL	CHICAGO-O HARE INTL	ORD
NORFOLK	VA	NORFOLK INTL	ORF
WORCESTER	MA	WORCESTER MUNI	ORH
OSHKOSH	WI	WITTMAN FIELD	OSH
KOTZEBUE	AK	RALPH WIEN MEMORIAL	OTZ
PADUCAH	KY	BARKLEY REGIONAL	PAH
WEST PALM BEACH	FL	PALM BEACH INTERNATIONAL	PBI
PENDLETON	OR	PENDLETON MUNI	PDT
PORTLAND	OR	PORTLAND INTL	PDX
PANAMA CITY	FL	PANAMA CITY-BAY COUNTY	PFN
NEWPORT NEWS	VA	PATRICK HENRY INTL ARPT	PHF
PHILADELPHIA	PA	PHILADELPHIA INTL	PHL
PHOENIX	AZ	PHOENIX SKY HARBOR INTL	PHX
PEORIA	IL	GREATER PEORIA	PIA
LAUREL/HATTIESBURG	MS	PINE BELT REGIONAL	PIB
POCATELLO	ID	POCATELLO MUNI	PIH
PIERRE	SD	PIERRE MUNI	PIR
PITTSBURGH	PA	GREATER PITTSBURGH INTL	PIT
PARKERSBURG	WV	WOOD COUNTY AIRPORT GILL ROBB WILSON FLD	PKB
PELLSTON	MI	EMMET COUNTY	PLN
PENSACOLA	FL	PENSACOLA REGIONAL	PNS

APPENDIX C

<u>CITY</u>	<u>STATE</u>	<u>AIRPORT NAME</u>	<u>F.A.A. ID</u>
PASCO	WA	TRI-CITIES	PSC
PETERSBURG	AK	PETERSBURG	PSG
PALM SPRINGS	CA	PALM SPRINGS MUNI	PSP
PUEBLO	CO	PUEBLO MEMORIAL	PUB
PRUDHOE BAY	AK	PRUDHOE BAY	PUO
PROVIDENCE	RI	THEODORE FRANCIS GREEN STATE	PVD
PORTLAND	ME	PORTLAND INTL JETPORT	PWM
RAPID CITY	SD	RAPID CITY REGIONAL	RAP
REDDING	CA	REDDING MUNI	RDD
REDMOND	OR	ROBERTS FIELD	RDM
RALEIGH-DURHAM	NC	RALEIGH-DURHAM	RDU
ROCKFORD	IL	GREATER ROCKFORD	RFD
RHINELANDER	WI	RHINELANDER-ONEIDA COUNTY	RHI
RICHMOND	VA	RICHARD EVELYN BYRD INTL	RIC
RIVERTON	WY	RIVERTON REGIONAL	RIW
RENO	NV	CANNON INTL	RNO
ROANOKE	VA	ROANOKE MUNI/WOODRUM	ROA
ROCHESTER	NY	ROCHESTER-MONROE COUNTY	ROC
ROSWELL	NM	ROSWELL INDUSTRIAL AIR CENTER	ROW
ROCHESTER	MN	ROCHESTER MUNI	RST
SAN DIEGO	CA	SAN DIEGO INTL-LINDBERGH FLD	SAN
SAN ANTONIO	TX	SAN ANTONIO INTL	SAT
SAVANNAH	GA	SAVANNAH MUNI	SAV
SANTA BARBARA	CA	SANTA BARBARA MUNI	SBA
SOUTH BEND	IN	MICHIANA REGIONAL	SBN
STOCKTON	CA	STOCKTON METROPOLITAN	SCK
LOUISVILLE	KY	STANDIFORD FIELD	SDF
SEATTLE	WA	SEATTLE-TACOMA INTL	SEA
SAN FRANCISCO	CA	SAN FRANCISCO INTO	SFO
SPRINGFIELD	MO	SPRINGFIELD REGIONAL	SGF
SHERIDAN	WY	SHERIDAN COUNTY	SHR
SHREVEPORT	LA	SHREVEPORT REGIONAL	SHV
SITKA	AK	SITKA	SIT
SAN JOSE	CA	SAN JOSE MUNI	SJC

APPENDIX C

<u>CITY</u>	<u>STATE</u>	<u>AIRPORT NAME</u>	<u>F.A.A. ID</u>
SAN ANGELO	TX	MATHIS FIELD	SJT
SAN JUAN	PR	PUERTO RICO INTL	SJU
SALT LAKE CITY	UT	SALT LAKE CITY INTL	SLC
SALEM	OR	MCNARY FLD	SLE
SALINA	KS	SALINA MUNI	SLN
SACRAMENTO	CA	SACRAMENTO METROPOLITAN	SMF
SANTA ANA	CA	JOHN WAYNE AIRPORT-ORANGE COUNTY	SNA
SPRINGFIELD	IS	CAPITAL	SPI
WICHITA FALLS	TX	SHEPPARD AFB/WICHITA FALLS MUNI	SPS
SARASOTA/BRADENTON/	FL	SARASOTA-BRADENTON	SRQ
ST LOUIS	MO	LAMBERT-ST LOUIS INTL	STL
CHARLOTTE AMALIE	VI	HARRY S TRUMAN	STT
CHRISTIANSTED	VI	ALEXANDER HAMILTON	STX
SIOUX CITY	IA	SIOUX CITY MUNI	SUX
SYRACUSE	NY	SYRACUSE HANCOCK INTL	SYR
TUSCALOOSA	AL	TUSCALOOSA MUNI	TCL
TALLAHASSEE	FL	TALLAHASSEE MUNI	TLH
TOLEDO	OH	TOLEDO EXPRESS	TOL
TAMPA	FL	TAMPA INTL	TPA
BRISTOL/JOHNSON/KINGSPORT	TN	TRI-CITY	TRI
FULSA	OK	TULSA INTL	TUL
TUCSON	AZ	TUCSON INTL	TUS
TRAVERSE CITY	MI	CHERRY CAPITAL	TVC
TWIN FALLS	ID	TWIN FALLS CITY-COUNTY ARPT, JOSLIN FLD	TWF
KNOXVILLE	TN	MC GHEE TYSON	TYS
UNALAKLEET	AK	UNALAKLEET	UNK
VISALIA	CA	VISALIA MUNI	VIS
VALDOSTA	GA	VALDOSTA MUNI	VLD
VALPARAISO	FL	EGLIN AFB	VPS
WRANGELL	AK	WRANGELL	WRG
YAKUTAT	AK	YAKUTAT	YAK
YAKIMA	WA	YAKIMA AIR TERMINAL	YKM
YOUNGSTOWN	OH	YOUNGSTOWN MUNI	YNG

C-11

NOTES AND COMMENTS

1 Report No NASA TM-87695		2 Government Accession No		3 Recipient's Catalog No	
4 Title and Subtitle Airport-noise Levels and Annoyance Model User's Guide				5 Report Date January 1986	
7 Author(s) *Richard DeLoach **James L. Donaldson **Margaret J. Johnson				6 Performing Organization Code 505-35-13-01	
9 Performing Organization Name and Address NASA Langley Research Center Hampton, VA 23665				8 Performing Organization Report No	
12 Sponsoring Agency Name and Address National Aeronautics and Space Administration Washington, DC 20546				10 Work Unit No	
15 Supplementary Notes *NASA Langley Research Center, Hampton, Virginia **Computer Sciences Corporation, Hampton, Virginia				11 Contract or Grant No	
16 Abstract The purpose of this document is to provide a guide for the use of the Airport-noise Levels and Annoyance Model (ALAMO) at the Langley Research Center computer complex. This document is divided into 5 primary sections, the Introduction, the Purpose of the Model, and an in-depth description of the following subsystems: Baseline, Noise Reduction Simulation and Track Analysis. For each subsystem, the user is provided with a description of architecture, an explanation of subsystem use, sample results, and a case runner's check list. It is assumed that the user is familiar with the operations at the Langley Research Center (LaRC) computer complex, the Network Operating System (NOS 1.4) and CYBER Control Language. Incorporated within the ALAMO model is a census database system called SITE II, licensed from CACI, Inc. SITE II is a registered trademark of CACI, Inc.				13 Type of Report and Period Covered Technical Memorandum	
17 Key Words (Suggested by Author(s)) Airport Community Noise Computer Model Footprint Population Subjective Response				14 Sponsoring Agency Code	
19 Security Classif (of this report) Unclassified		20 Security Classif (of this page) Unclassified		21 No of Pages 129	22 Price* A07
				18 Distribution Statement Unclassified - Unlimited Subject Category 71	

End of Document