

DAA/MARSHALL

H78175 B
NASA order # ~~1875~~

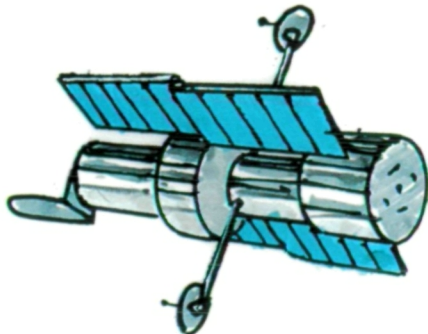
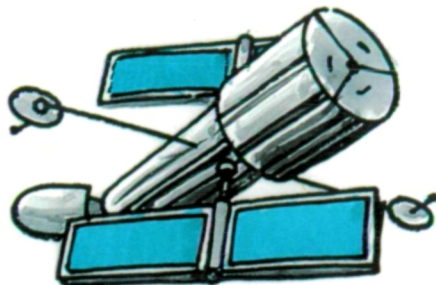

THE GREAT OBSERVATORIES

FOR SPACE ASTROPHYSICS



ORIGINAL CONTAINS
COLOR ILLUSTRATIONS

THE GREAT OBSERVATORIES

FOR SPACE ASTROPHYSICS



The origin of the Universe



The fundamental laws of physics



The birth of stars, planets and life



ORIGINAL CONTAINS
COLOR ILLUSTRATIONS

NASA

National Aeronautics and
Space Administration

Astrophysics Division

21M585

An Astronomical Heritage

2

Although astronomy is a science that has been practiced since ancient times, the Universe remains veiled in mystery. The ruins of Stonehenge and Chichen Itza, the clay tablets of Babylon, the cosmic models of Greek schools of thought, and the celestial mythologies of various cultures offer historical evidence for widespread astronomical observations. Until Galileo revolutionized astronomy with the telescope, however, our understanding of the Universe owed more to preconceptions than to precise observations and measurements. Since Galileo first peered into the heavens with a device more sensitive than the human eye, telescopes and observatories have proliferated, revealing a richly varied Universe.

Astronomers study the nature of the Universe by observing its contents and behavior, while astrophysicists seek to understand these observations in terms of consistent laws of physics. Limited for centuries to observations in the visible band of the electromagnetic spectrum, scientists now have access to the Universe at virtually all wavelengths. The tremendous advance that has occurred in our lifetimes became possible with spaceflight. Placing sensitive astronomical instruments above the filtering atmosphere opened new windows onto the cosmos and revealed intriguing objects and events there.

Today we are still motivated by the ancient urge to observe, measure, compute, and thereby come to greater understanding of the nature of the Universe. We have at our disposal the most advanced technology, and we have new opportunities to place entire observatories into space for investigations across the spectrum. Our astronomical heritage flourishes on the insights and discoveries of this new Era of Space Observatories.

ASTRONOMY

TIMELESS EXPLORATION OF THE UNIVERSE

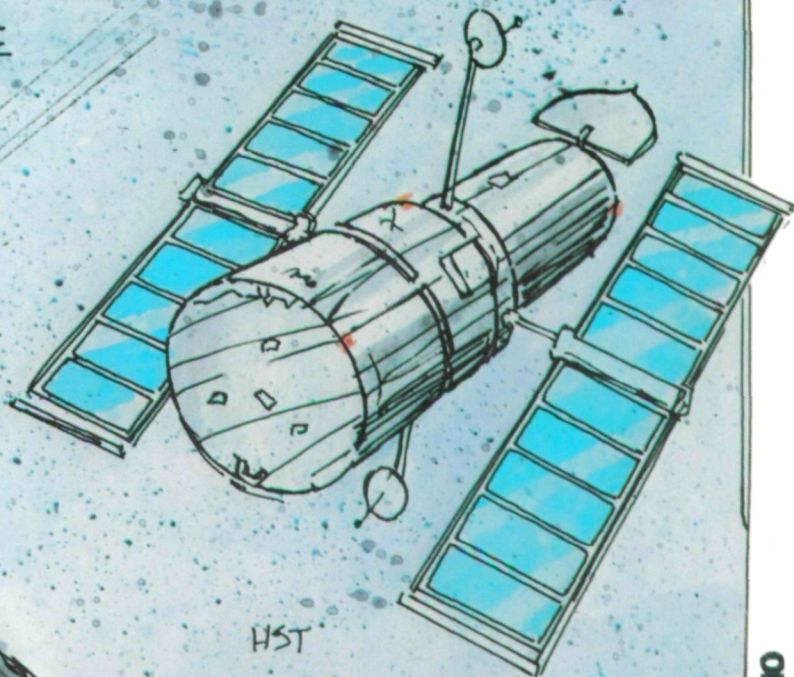
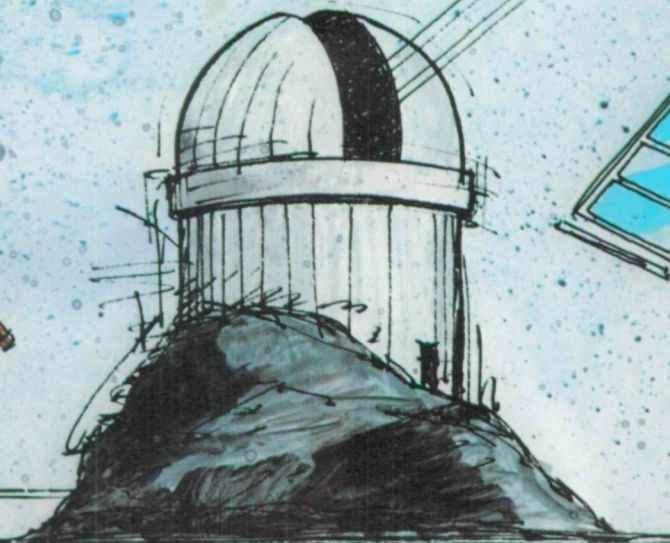
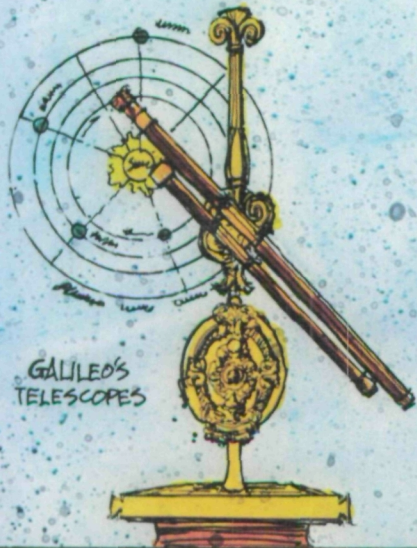

STONEHENGE

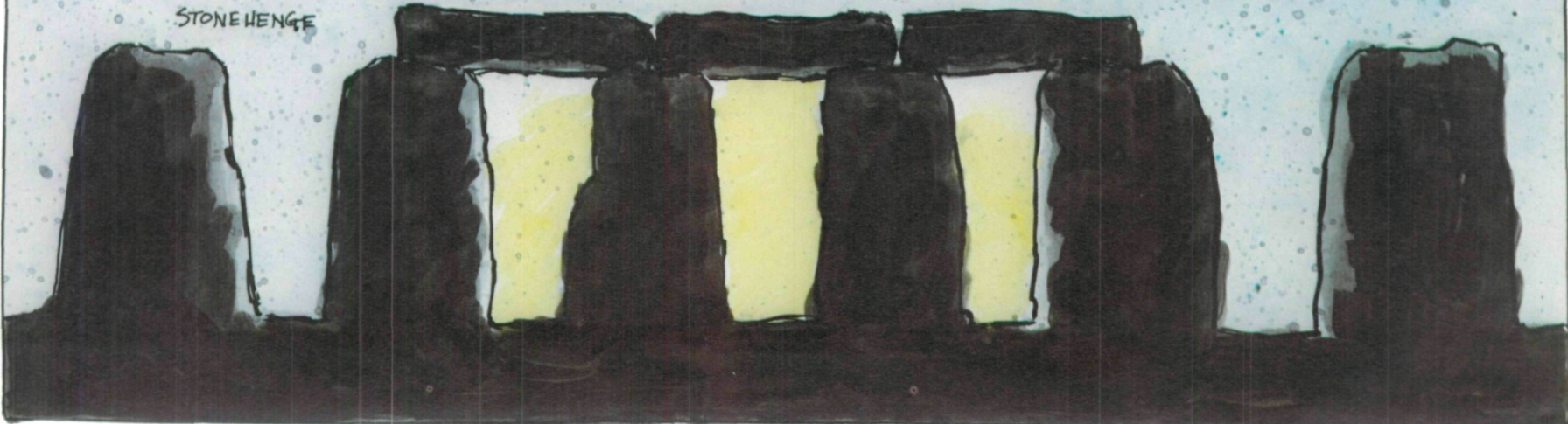

ORIGINAL PAGE IS
OF POOR QUALITY

The Popular Appeal of Astronomy

4

Astronomy is in the midst of its most exciting period since Galileo probed the heavens with the first telescope. Widespread public interest is evident in the flowering of amateur astronomy societies, the popularity of space science and astronomy publications, and the attendance figures for astronomy lectures, films, museum exhibits, and planetarium shows.

In the United States today, there are at least a quarter million amateur astronomers, many of them children who will become the scientists and engineers of tomorrow. The National Air and Space Museum, the country's principal museum dedicated to space exhibits, has attracted up to 15 million visitors annually, and attendance continues to grow. More than 350,000 visitors a year pay admission to attend the planetarium shows there. A thousand other planetaria exist around the country, most of them in high schools, where their educational value is especially significant. Audiences for astronomy lectures and films are typically large and enthusiastic.

Television productions based on astronomy are extraordinarily popular, attracting millions of viewers. Many of the mass-circulation magazines (including Time, Newsweek, National Geographic, Smithsonian, Omni, Scientific American, Discover, and others) vividly report astronomical discoveries to millions of readers.

The popular appeal of astronomy, for education and entertainment, is enormous. Almost everyone is curious about the Universe.

ALMOST EVERYONE IS CURIOUS ABOUT THE UNIVERSE.

PLANETARIA



POPULAR PUBLICATIONS



TELEVISION SPECIALS



AMATEUR ASTRONOMERS

Careers in Astronomy

6

An education in astronomy and space science can lead to a variety of careers. Some graduates apply their skills to the design of new techniques for observing and interpreting cosmic processes at great distances across the Universe. Others study our more immediate environment within the solar system, in part to determine causes of climatic variations. Still others become teachers or put their talents to use in industry and government.

Research:

Scientists extend the frontiers of knowledge in the various disciplines of astronomy and astrophysics by observation, analysis, and theory. They find employment in universities, observatories, and government centers.

Teaching:

The study of the Universe is important, and popular, in the curriculum at all levels:

- ☆ General science in elementary and secondary schools
- ☆ Basic astronomy in colleges and universities
- ☆ Graduate and postgraduate courses at dozens of universities.

Industry:

Many people interested in astronomy join industry to conduct applied research in optics, electronics, and computer science. Others become involved in instrument design and fabrication. These scientists and engineers are responsible for the advanced technology that makes further discovery possible.

NASA:

Astronomers provide leadership for the nation's space program, managing the pioneering exploration of space and meeting the challenges of tomorrow.

EDUCATION & CAREERS

SCIENTISTS AND ENGINEERS OF THE FUTURE

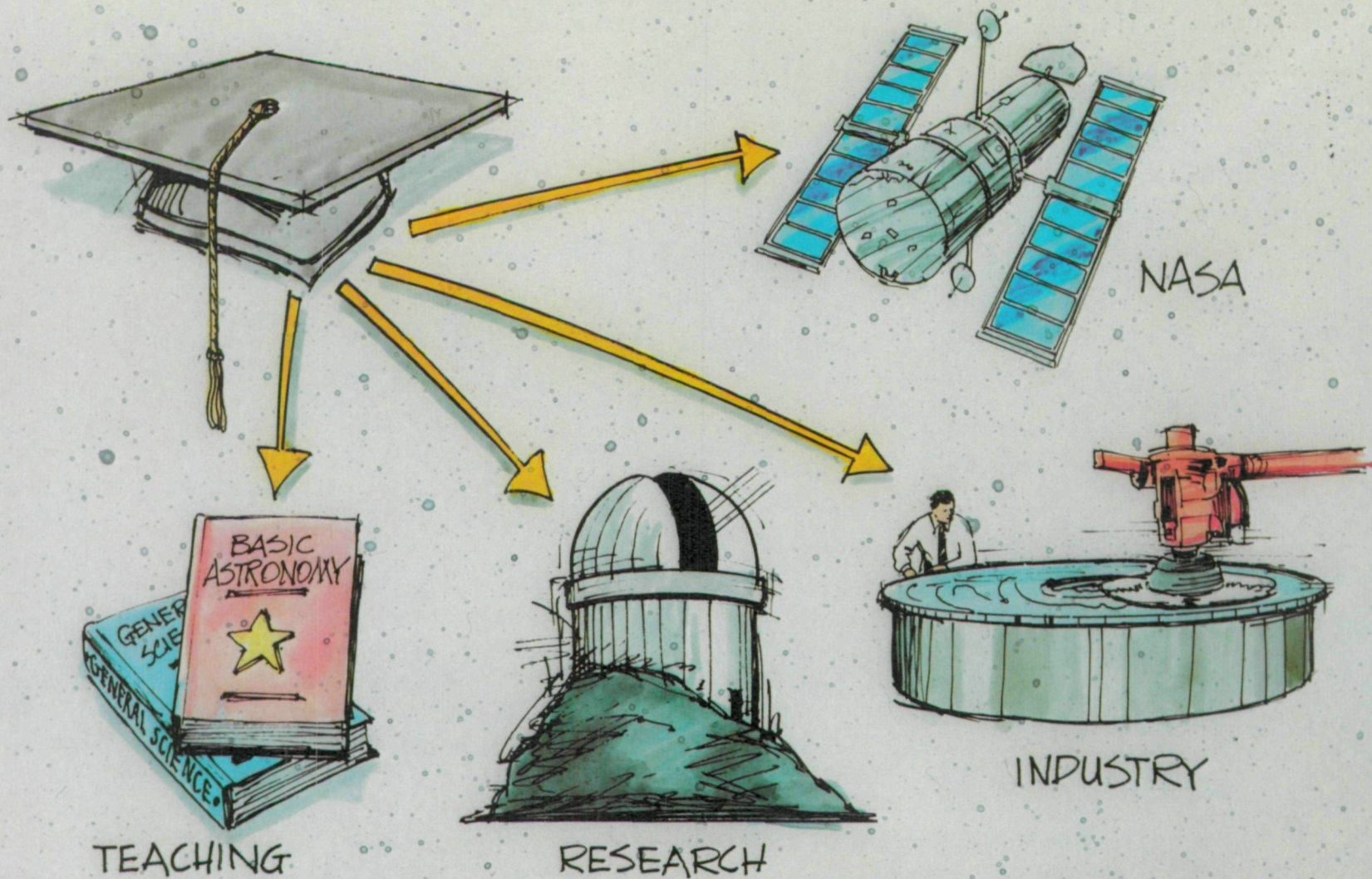

Astronomy and Technology: A Continuing Exchange of Novel Ideas

8

Over the centuries, astronomy and technology have progressed hand in hand. The study of the Universe has benefited from improved observational devices and techniques. By the same token, developments in astronomy have led to practical applications in other disciplines.

1500-1600

- ☆ Increasingly accurate maps of the sky for navigation

1600-1700

- ☆ Christian Huygen's invention of the pendulum clock for navigational time keeping
- ☆ Newton's development of the calculus, the laws of motion and the law of universal gravitation as a means to explain the motions of planets and comets

1800-1900

- ☆ Increasingly sophisticated optical innovations by astronomers (William Herschel, Fraunhofer, Lord Rosse, Alvan Clark, and many others)
- ☆ Development of increasingly sensitive photographic techniques
- ☆ Lockyer's discovery of a new chemical element, helium, on the sun before it was known on Earth

1900-NOW

- ☆ Hans Bethe's theoretical prediction of hydrogen fusion at the center of the sun, a precursor for all modern fusion efforts
- ☆ Lyman Spitzer's development of astrophysical plasma theory, the basis of present devices for releasing energy from controlled fusion
- ☆ Very long baseline radio astronomy techniques used in high-precision geodesy to survey the structure of the Earth
- ☆ Techniques of celestial mechanics, precursors to the development of accurate spacecraft navigation.

The mutually beneficial interaction between astrophysics and technology continues today.

ASTRONOMY AND TECHNOLOGY

THE CALCULUS
AND
PLANETARY MOTION

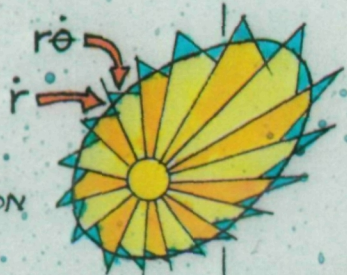

PENDULUM
CLOCK

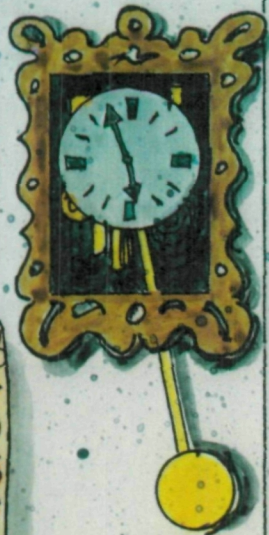

CELESTIAL
MAPS

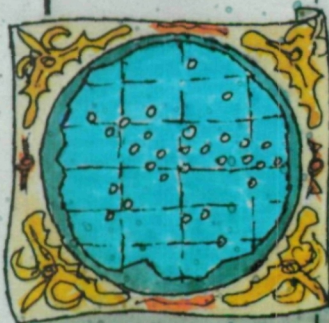

IMPROVED
TELESCOPES

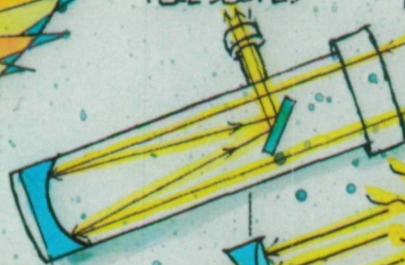

HYDROGEN
FUSION IN
THE SUN

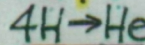

DISCOVERY
OF HELIUM

COMPOUND
LENS



PHOTOGRAPHY

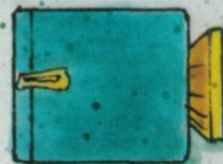

SPACECRAFT
NAVIGATION

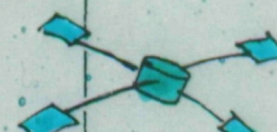

CONTROLLED
FUSION IN
LABORATORY



HIGH-PRECISION
GEODESY



YEARS: 1500

1600

1700

1800

1900

2000

ORIGINAL PAGE
COLOR PHOTOGRAPH

ORIGINAL PAGE
COLOR PHOTOGRAPH

Observing the Universe with Improved Sensitivity

10

Over the past two decades, NASA has introduced increasingly sensitive instruments into space. In astronomy, families of telescopes have been developed and placed in orbit for observations across the entire electromagnetic spectrum, especially those parts blocked by the atmosphere.

Each successive telescope has extended the limits of sensitivity and provided greater insight into the structure of stars, galaxies, and the cosmos. For these successes, new technologies had to be created and exploited.

Members of the new generation of space observatories offer significant new gains in sensitivity through state-of-the-art technology.

- ☆ The GAMMA RAY OBSERVATORY (GRO) will explore the most energetic part of the spectrum across a much greater wavelength range than its predecessors.
- ☆ The ADVANCED X-RAY ASTROPHYSICS FACILITY (AXAF) will cover the X-ray portion of the spectrum with a hundred-fold improvement in sensitivity.
- ☆ The HUBBLE SPACE TELESCOPE (HST) will penetrate deep into the Universe in visible and ultraviolet light, expanding the volume of observable space several hundred times.
- ☆ The SPACE INFRARED TELESCOPE FACILITY (SIRTF) will span the infrared part of the spectrum with a thousand-fold increase in sensitivity.

To complement these sensitive space telescopes, the astronomical community is currently considering two powerful new ground-based observatories: the Very Long Baseline Array (VLBA), an intercontinental network of radio telescopes, and the National New Technology Telescope (NNTT), a large optical telescope. In addition, NASA's Solar Optical Telescope (SOT) will provide detailed data on our nearest star, the sun, to augment our studies of distant stars and cosmic processes.

With these new observatories, we will be able to open more of the Universe to scrutiny, to look back in time and space for order and meaning.

SENSITIVITY OF IMAGING ASTRONOMICAL INSTRUMENTS

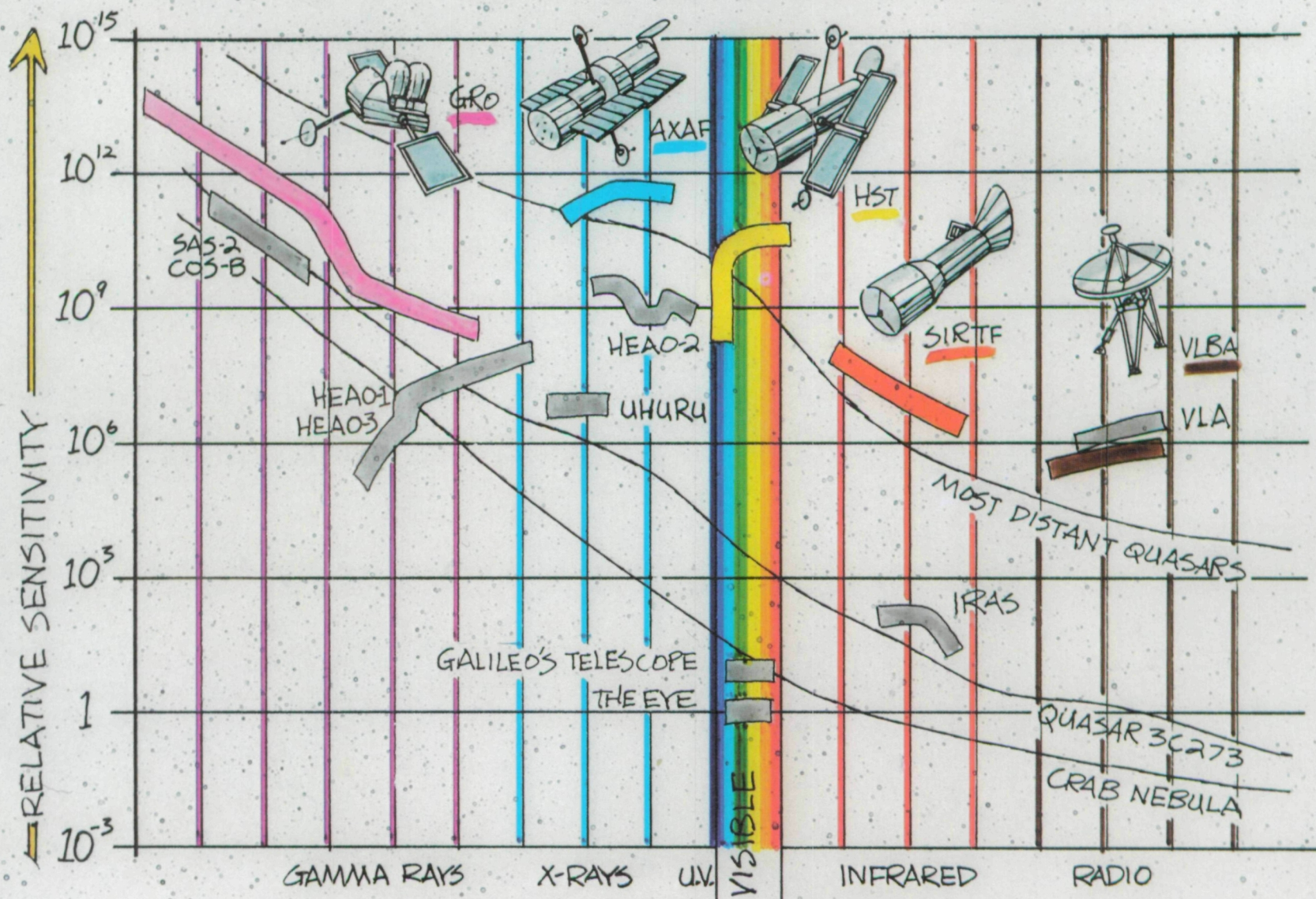

Technology for the Future

12

Astronomical observations pose some of the greatest challenges to modern technology. Engineering difficulties overcome by astrophysicists often provide solutions to more general technical problems. We expect new technologies developed for the four space observatories to stimulate future applications in space and on Earth.

- ☆ GRO introduces a propulsion system that can be refueled in orbit to extend the lifetime of the observatory.
- ☆ AXAF's nested grazing-incidence mirrors will provide the most advanced X-ray focussing optics presently known. Previous X-ray astronomical advances have already led to commercial applications in low-dosage imaging systems.
- ☆ HST has already pioneered the construction of higher precision optics than any ever built. Its spacecraft pointing control will cross new thresholds of accuracy.
- ☆ SIRTf will provide longer endurance for ultra-low-temperature apparatus in space, a requirement for many other high-precision technologies. Previous infrared astronomical missions pioneered the handling of liquid helium, the ultimate refrigerant, in space. However, SIRTf introduces the new capability of replenishing liquid helium coolant in orbit.

These advanced technologies will be of benefit not only for scientific research but also for practical down-to-Earth uses. We can only guess what new applications will result from the spread of these technologies into everyday life.

AXAF GRAZING INCIDENCE OPTICS

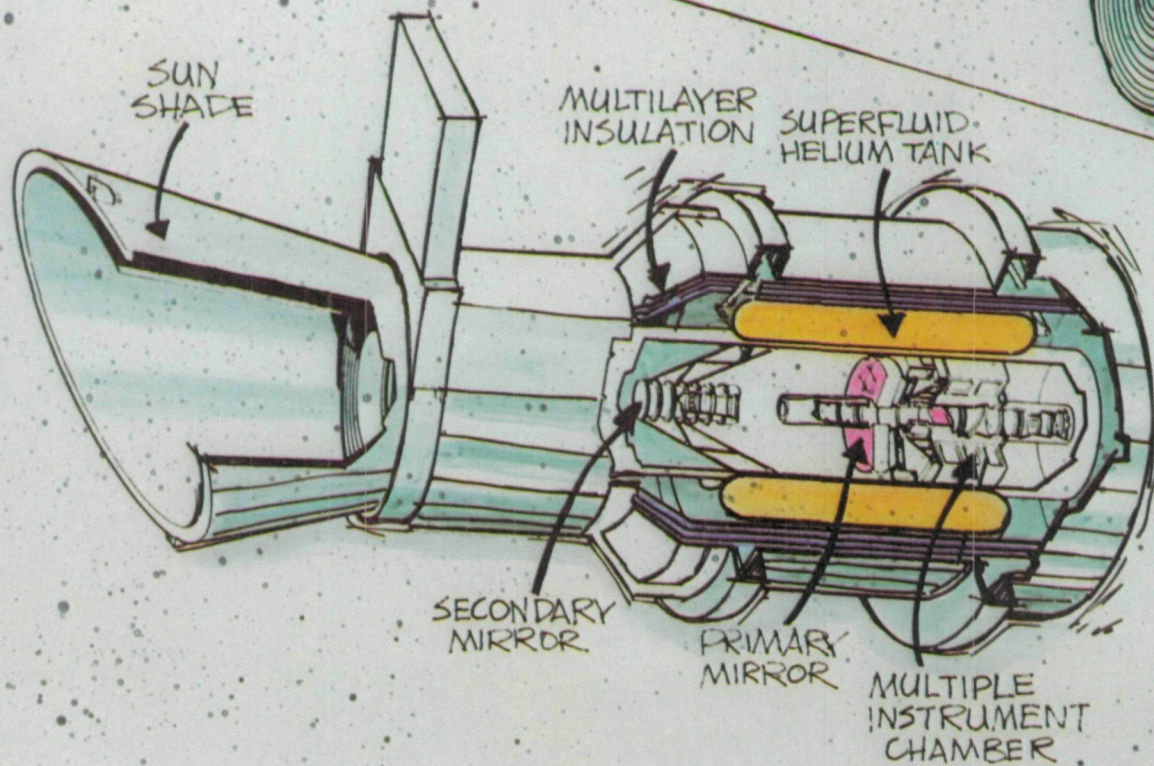
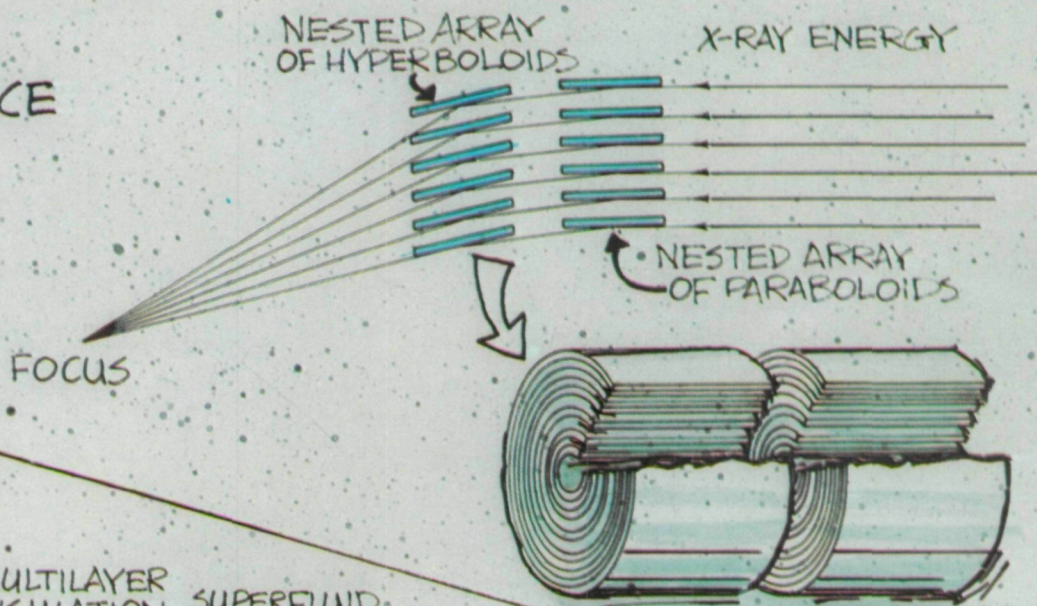

SIRTf SUPERCOOLED OPTICS

Discovering the Nature of the Universe

14

Discoveries:

1. Stars
2. Planets
3. Novae
4. Comets
5. Moons
6. Rings
7. Galactic Clusters
8. Clusters of Galaxies
9. Interplanetary Matter
10. Asteroids
11. Multiple Stars
12. Variable Stars with Nebulosity
13. Planetary Nebulae
14. Globular Clusters
15. Ionized Gas Clouds
16. Cold Interstellar Gas
17. Giants/Main Sequence Stars
18. Cosmic Rays
19. Pulsating Variables
20. White Dwarfs
21. Galaxies
22. Cosmic Expansion
23. Interstellar Dust
24. Novae/Supernovae
25. Galaxies With/Without Gas
26. Supernova Remnants
27. Radio Galaxies
28. Magnetic Variables
29. Flare Stars
30. Interstellar Magnetic Fields
31. X-Ray Stars
32. X-Ray Background
33. Quasars
34. Microwave Background
35. Masers
36. Infrared Stars
37. X-Ray Galaxies
38. Pulsars
39. Gamma-Ray Background
40. Infrared Galaxies
41. Superluminal Sources
42. Gamma-Ray Bursts
43. Unidentified Radio Sources

Astronomical discoveries have been occurring at a quickening pace since the development of the first telescope, and particularly in the past few decades. These discoveries are closely linked to the introduction of new technologies into the field.

The discovery of X-ray stars and X-ray galaxies in the 1960's was made possible by the flight of first-generation X-ray telescopes on some of the early rockets. Infrared stars and galaxies were discovered about the same time with novel detectors that had just become available.

The listed discoveries, though impressive, are only a fraction of those remaining to be made. New technologies in the era of space observatories will certainly lead to further discoveries just as striking as those of the past.

What might these be? Possibly black holes at the distances of the nearest stars, having masses similar to those of ordinary stars and detected through the X-ray emission produced as the black hole gravitationally accretes interstellar matter. Or perhaps an infrared planet orbiting a nearby star with a period identical to that of some unusual radio signals from the same part of the sky, suggesting the existence of an intelligent, technically advanced civilization. Or else bizarre "shadow galaxies" or networks of massive cosmic "strings," predicted by some of our Grand Unified Theories of elementary particle physics but never seen in the laboratory. These particles, produced only at the enormous energies prevalent in the early exploding Universe, would be revealed through the X-ray emission from hot gas gravitationally attracted to them.

THE INCREASING PACE OF DISCOVERY

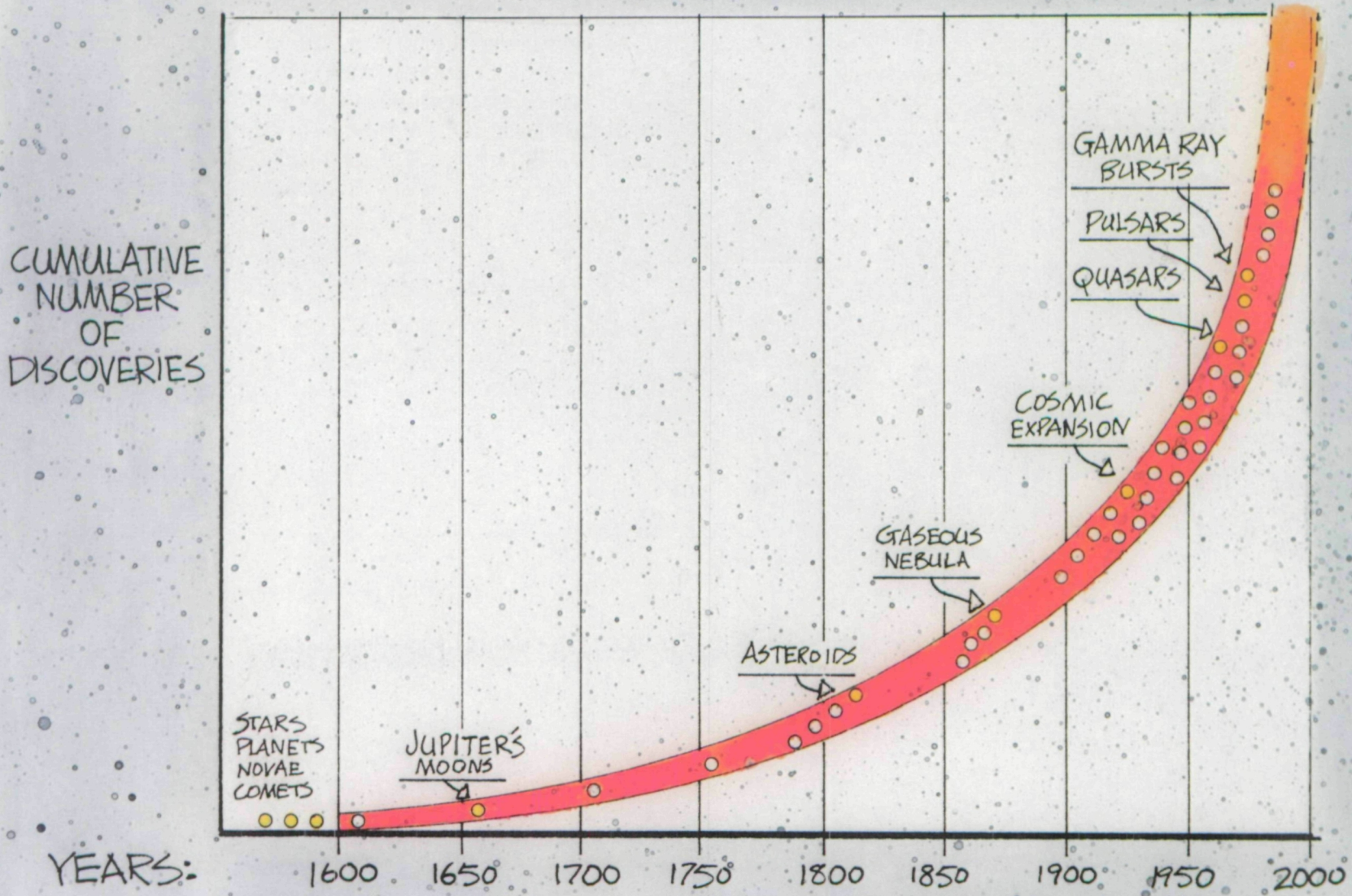

NASA's Role in Space Astronomy

16

NASA's major contribution to modern astrophysics has been the agency's ability to place powerful new telescopes into orbit. From their vantage point in space, these observatories can sense gamma rays, X-rays, and ultraviolet, optical, and infrared radiation undisturbed by the distorting, absorbing atmosphere.

Discoveries of ultra-hot gas in clusters of galaxies, gamma background-radiation from the Universe, and galaxies which emit virtually all their energy in the infrared have all resulted from this capability. Observations in each wavelength band reveal a new Universe.

OBSERVATORIES IN SPACE, HIGH ABOVE THE EARTH'S ABSORBING ATMOSPHERE, PROVIDE NEW VISTAS ON THE UNIVERSE. NASA HAS LONG BEEN THE LEADING ARCHITECT OF SPACE OBSERVATORIES.

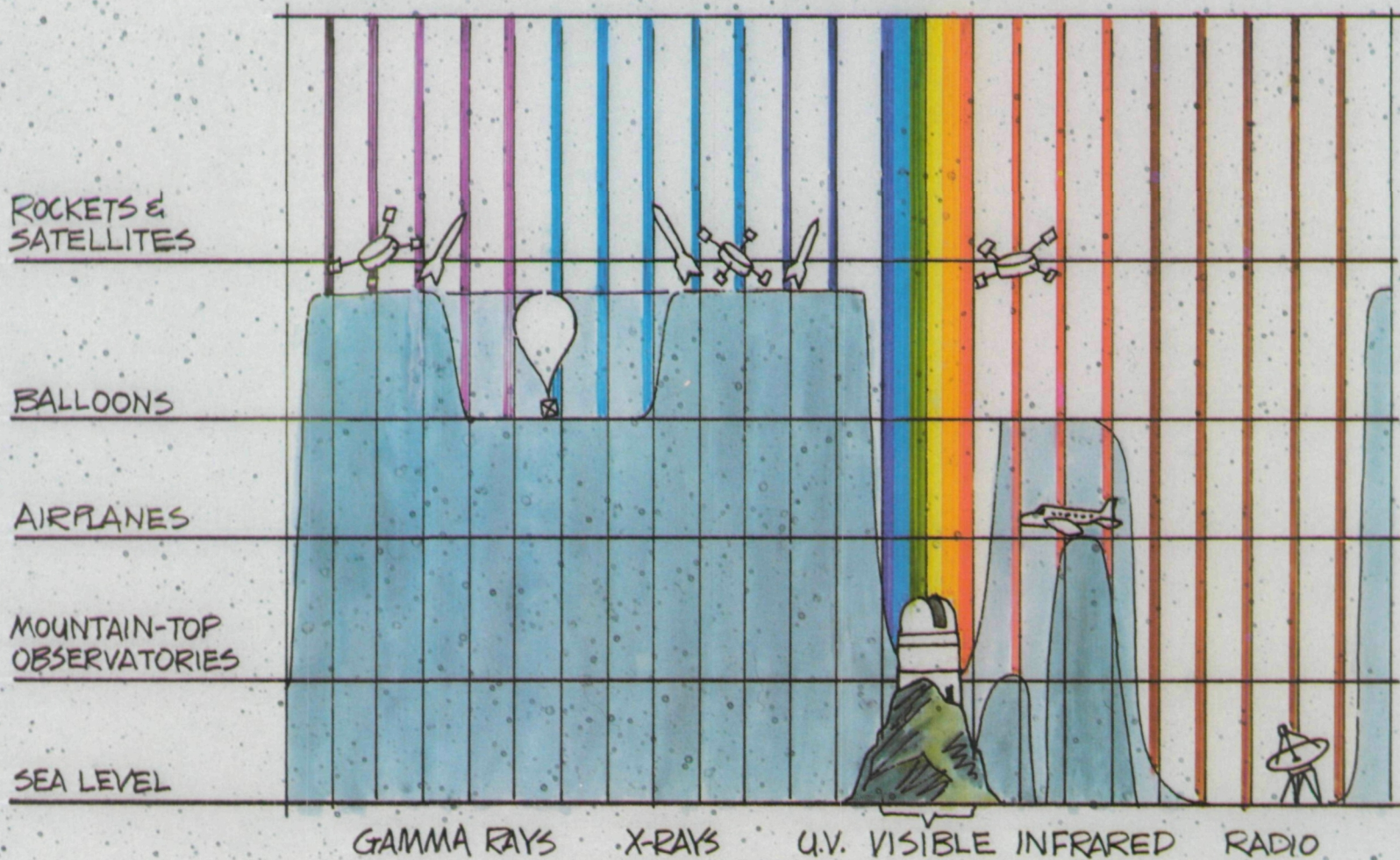

The Milky Way

18

Our galaxy, the Milky Way, is populated by star clusters, dusty clouds of turbulent gas, exploding or collapsing stellar masses, and gradually evolving systems of stars—phenomena that are revealed by observations at widely differing wavelengths. Through the use of powerful telescopes, we hope to observe and comprehend these processes that reflect the birth of stars, their eventful lives, and their ultimate death.

- ☆ At radio wavelengths we detect cool clouds in space; some are destined to contract to form new stars, while others are ejected at high speeds, emitting radio waves characteristic of water vapor masers.
- ☆ At infrared wavelengths we probe clouds warmed by stars that have formed within them; we also register dying stars throwing off shells of matter.
- ☆ At visible wavelengths we see millions of stars like our sun, and we can study their evolution as they consume their nuclear energy.
- ☆ At ultraviolet wavelengths we detect the hottest stars. Some are still actively consuming nuclear energy; others, like white dwarfs, are dying remnants of small stars which once were active.
- ☆ At X-ray wavelengths we see matter at ultra-high temperatures falling on neutron stars—the remains of more massive dead stars.
- ☆ At gamma-ray wavelengths we detect sudden bursts of intense emission from sources not yet understood.

By combining these different pictures of our galaxy, we gain greater understanding, while any one of these observations alone would leave us puzzled.

INTENSELY HOT AND EXTREMELY COLD COSMIC MATTER
RADIATE AT WIDELY DIFFERING WAVELENGTHS.

GAMMA BURSTS X-RAY PULSARS HOT STARS WARM DUST COLD GAS, MASERS

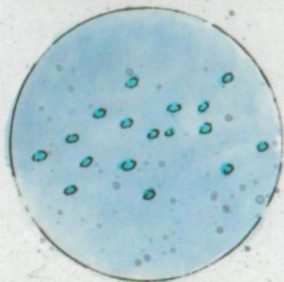
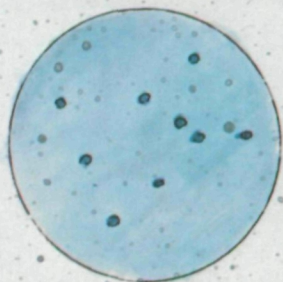

OBSERVATORIES TUNED TO EACH WAVELENGTH BAND WILL REVEAL A COMPLETE PICTURE.

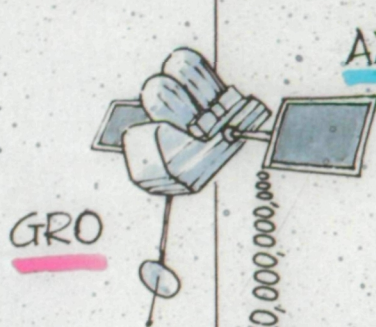

AXAF

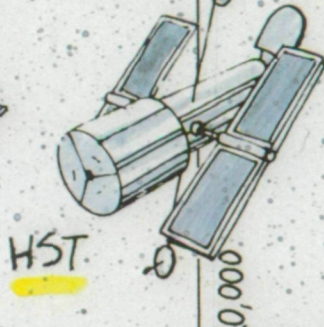
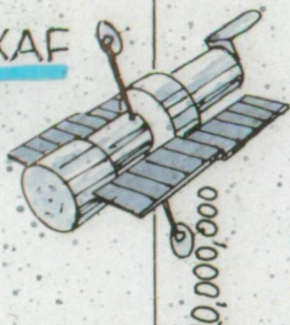

HST

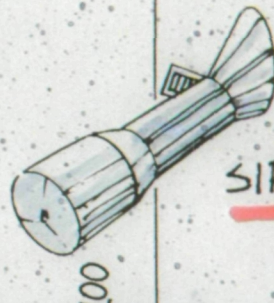

SIRTF



VLBA



GAMMA RAYS

X-RAYS

UV

VISIBLE LIGHT

INFRARED

MICROWAVE RADIO

A Typical Cluster of Galaxies

20

The gamma ray emission from clusters of galaxies is expected to emanate primarily from quasars and from the nuclei of active galaxies. With the next generation observatory, GRO, we will be able to determine whether most of the known gamma radiation arriving from the Universe originates in quasars, or whether there are other powerful, but presently unknown, sources of gamma ray emission.

The X-ray map of a cluster frequently is dominated by a hot, diffuse plasma permeating intergalactic space. Quasars also show up on such a map, while individual galaxies appear much fainter.

Pictures recorded at visible wavelengths show starlight from all the members of a cluster of galaxies.

Infrared radiation predominantly comes from dusty galaxies in which dust grains absorb virtually all the starlight and re-emit this energy at longer wavelengths.

The radio view is dominated by the luminous core of a massive central galaxy, from which magnetically channeled jets of electrons and protons are ejected at nearly the speed of light.

CLUSTERS OF GALAXIES PROVIDE AN
EVEN GREATER CONTRAST IN APPEARANCE.

GAMMA RAYS

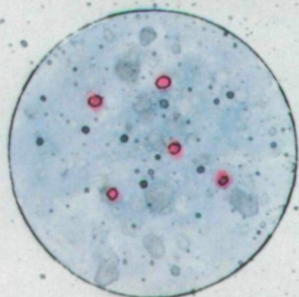

QUASARS

X-RAYS

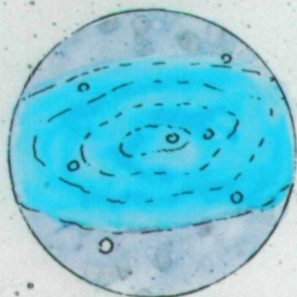

HOT PLASMA

VISIBLE



STARS IN
GALAXIES

INFRARED



HEATED
DUST

RADIO



ENERGETIC
ELECTRONS
& PROTONS



ARE FURTHER CHANNELS
OF INVESTIGATION LIKELY TO
REVEAL STILL GREATER COMPLEXITIES?

What if We Could Observe in Just One or Two Wavelength Bands?

22

Many discoveries become apparent only through a combination of observations.

For example, quasars, discovered in 1963 by virtue of their powerful radio emission, had been recorded on photographic plates for many decades. Nobody had noticed them because they looked so much like normal stars. Later, more extensive optical data showed quasars to lie far out in the Universe. Recent observations with NASA's HEAO-2 (Einstein) observatory have shown quasars to be even more powerful emitters of X-rays than of radio or light waves.

To understand the nature of quasars and many other celestial objects, we need to study them at all wavelengths.

WHAT IF WE COULD SEE
ONLY ONE OR TWO COLORS OR WAVELENGTHS?

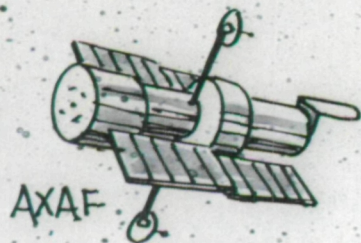

DISCOVERY

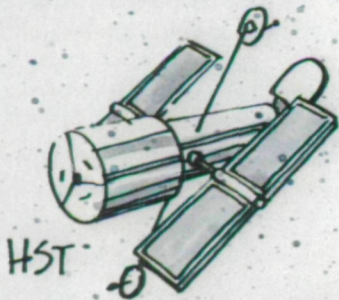

DISCOVERY

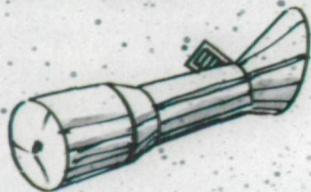

DISCOVERY

WE MIGHT MISS A

DISCOVERY

Fundamental Questions in Astrophysics

24

Our thoughts about the long-term future of the human race involve fundamental questions about the nature of the cosmos – its past and its future, its governing physical laws, its harsh explosions, and its potential for hospitable planetary systems. We ask:

- ☆ How did the Universe form and evolve in the first few seconds? Can we learn more about the basic laws of physics from the effects they have had on the structure of the Universe?
- ☆ How did galaxies and clusters of galaxies initially form and how have they evolved?
- ☆ Will we need new laws of physics to describe observed phenomena? Will the Law of Gravitation have to be modified or will new fundamental particles be found to play a central role?
- ☆ Can massive stars or galaxy-size aggregates collapse to form black holes, liberating enormous amounts of energy? Are such black holes the energy sources of quasars and active galactic nuclei? How do these powerful sources affect the galaxies in which they reside?
- ☆ How do stars and star clusters form and die, and how do they interact with interstellar matter? Do shock waves from stars dying in supernova explosions induce star formation? How do magnetic fields arise in interstellar matter and in stars?
- ☆ How are planetary systems formed? How many stars have planets and how many might be habitable? Where and how did life start? Are there intelligent civilizations elsewhere in the Universe?

FUNDAMENTAL QUESTIONS:

HOW DID THE UNIVERSE BEGIN?

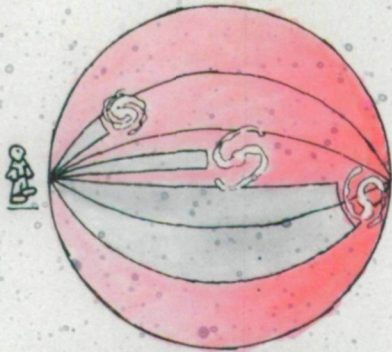
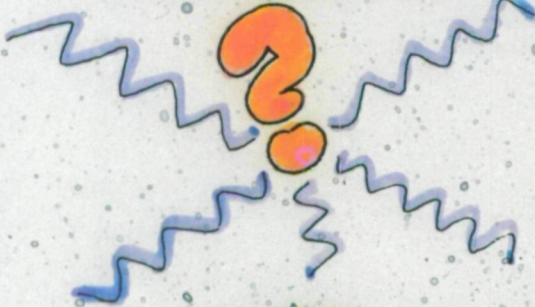

WILL WE FIND NEW LAWS OF PHYSICS THAT GOVERN COSMIC EVOLUTION?

HOW ARE PLANETS FORMED?

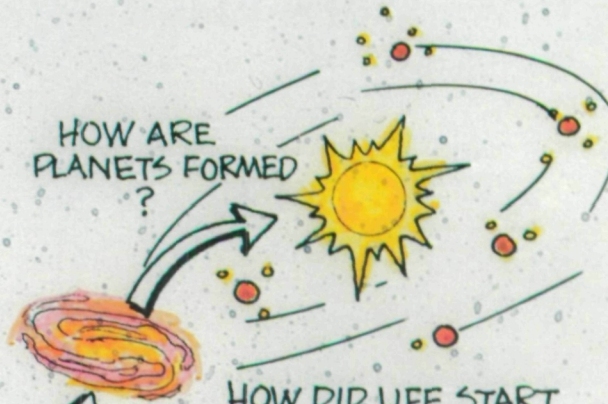

HOW DID LIFE START?

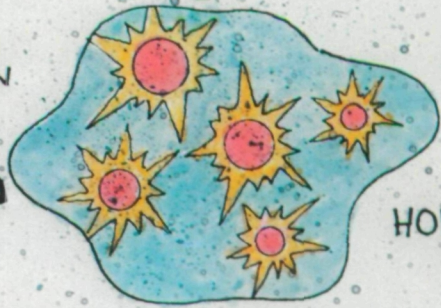

HOW ARE STARS BORN?

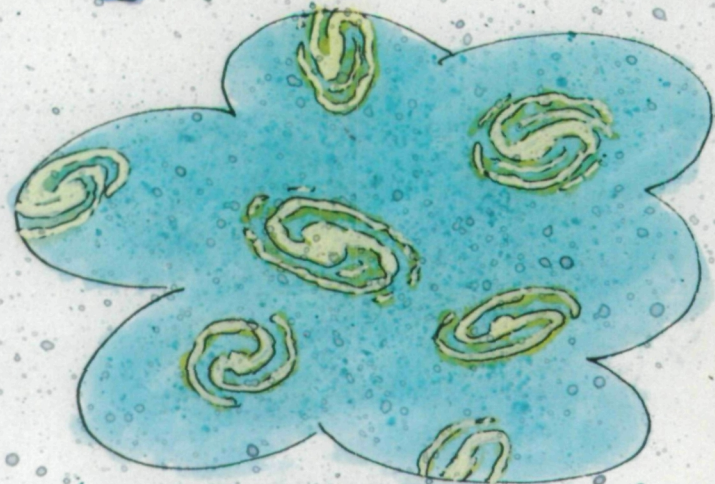

HOW DID GALAXIES FORM?

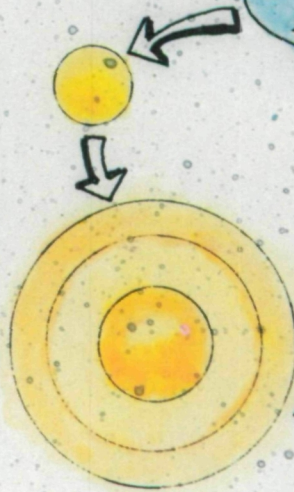

HOW DO STARS DIE?

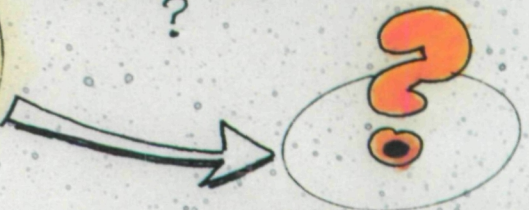

DO BLACK HOLES EXIST?

ORIGINAL PAGE
COLOR PHOTOGRAPH

Birth Places of Stars

26

We know that stars must be forming in our galaxy today. Although the Milky Way is more than ten billion years old, we see stars that are thousands of times younger. A star can continue to shine only as long as it has a supply of energy to radiate away into space. The most luminous stars quickly exhaust these limited supplies and must be young, no older than a few million years. Young stars are always found near dark, dusty gas clouds, the birth places of stars.

The gaseous central portions of a cloud contract, becoming ever more compact until a star is born. The early collapse of a contracting core can be detected only with infrared and radio observations that penetrate the dust-shrouded regions. SIRTf and radio telescopes have this capability. Once a young star is formed and its cocoon of dust is blown away by powerful stellar winds, eruptive magnetic processes that mark the final stages of star formation can be studied with sensitive optical telescopes such as HST.

Similar magnetic phenomena occur, on a smaller scale, on the surface of the sun, our best laboratory for studying these violent outbursts. The Solar Optical Telescope (SOT) will be a powerful tool not only for investigations of the sun but also for insight into the storage of magnetic energy at the surfaces of young stars. This energy is later unleashed sporadically in enormous flares.

OUR SUN IS ONE OF COUNTLESS STARS.
ARE STARS FORMING EVEN NOW IN INTERSTELLAR CLOUDS?

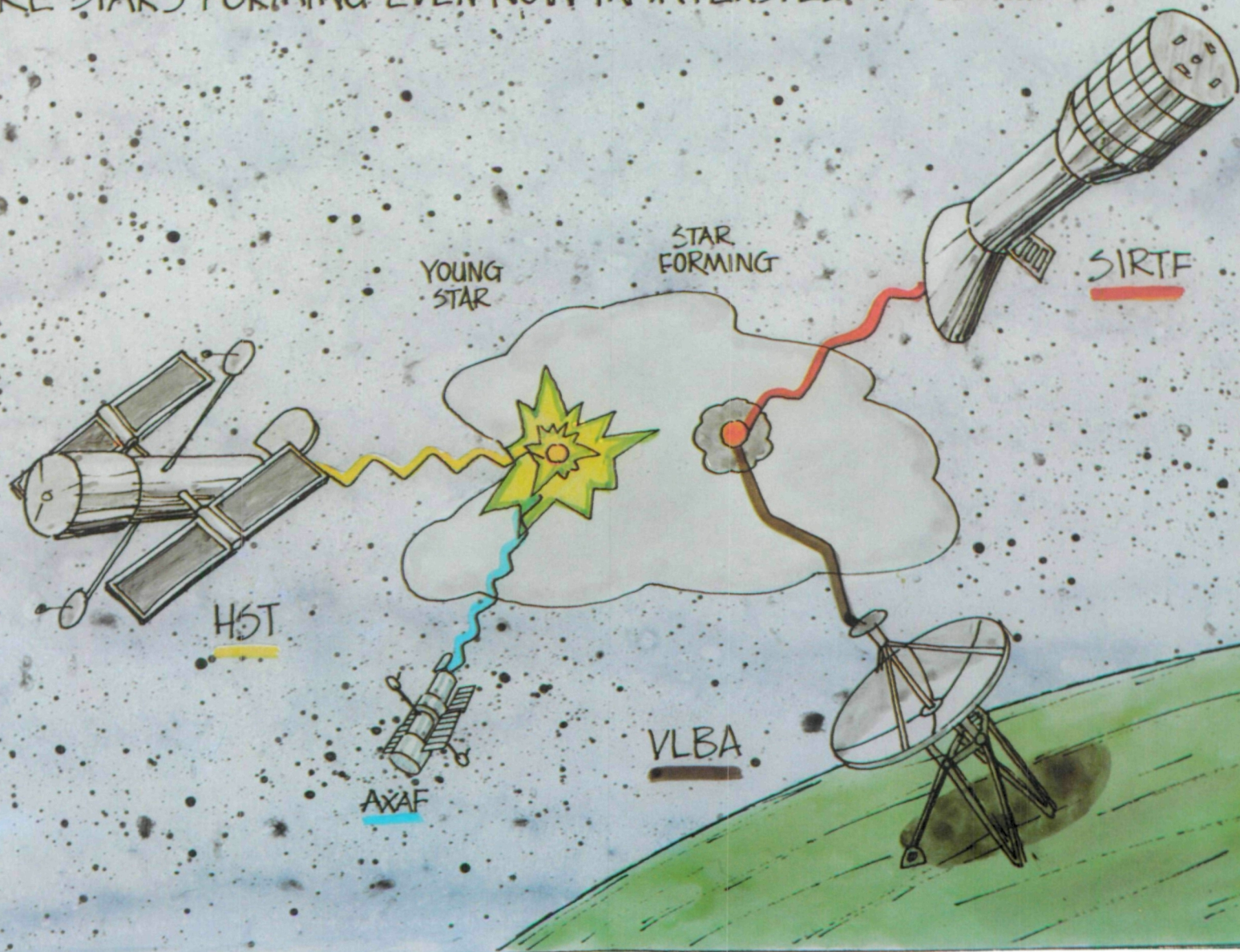

Life Cycles of Stars

28

The birth of stars may well be triggered by the explosion of a supernova that compresses a nearby dusty cloud of gas, which then collapses to form a new group of stars. Some of these are more massive than others and begin to shine thousands of times more brightly than the sun. Such stars consume their supply of nuclear fuel in a few million years and collapse to form a neutron star, or possibly a black hole. In this collapse, enormous amounts of energy are suddenly liberated, and the outer shell of the star is hurled into space in another supernova explosion. X-ray observations of the remains of such explosions can tell us much about the original star as well as the exploding shell.

Less massive stars, like our sun, never explode as supernovae. Instead, they shine steadily, at a far more subdued rate, for ten billion years before continuing their lives, briefly as red giant stars and finally as faint white dwarfs. Some of these stars may originally be enveloped by a disk from which a system of planets settles out.

Currently we have no way of knowing how many stars are orbited by planets or how many stars are encircled by disks. We hope to answer these questions by making optical observations with HST and infrared observations with SIRTf.

WHAT IS THE LIFE CYCLE OF STARS?
DO STARS FORM BECAUSE STELLAR EXPLOSIONS (SUPERNOVAE)
COMPRESS NEIGHBORING GAS CLOUDS?

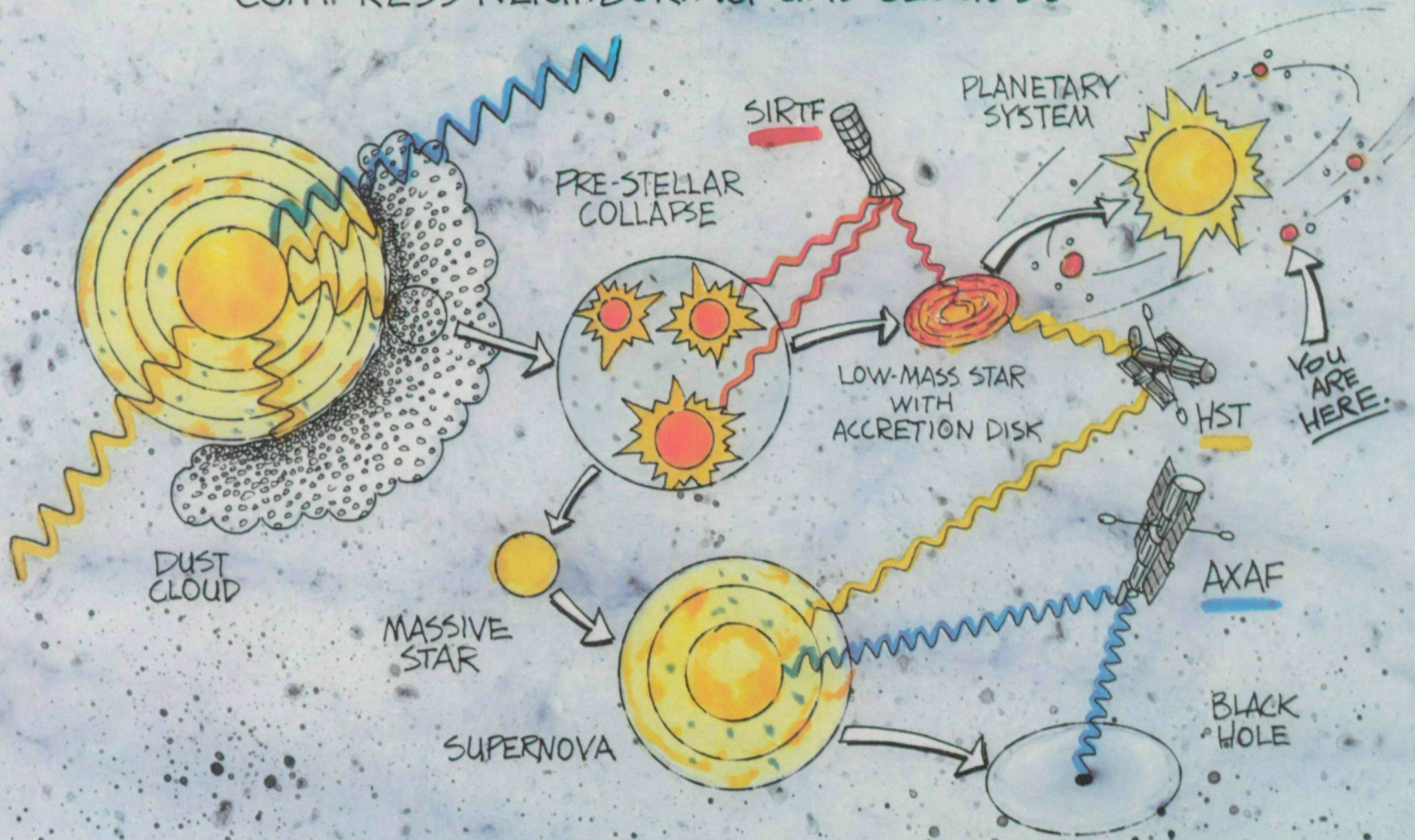

Quasars

30

Quasars are distant, massive bodies so luminous that they outshine surrounding galaxies a hundred times. We do not know how to explain this immense power. One possible model of a quasar consists of an intensely hot central source emitting gamma rays and embedded in X-ray-emitting plasma. Enveloping dust clouds absorb much of the emitted energy, re-radiating it at far-infrared wavelengths. An outermost, unobscured layer also radiates at ultraviolet and visible wavelengths. Plasma beams ejected from the central source at nearly the speed of light power distant radio lobes.

How can so much energy be radiated from so compact a source? How can we account for the rapid variations in luminosity, from one month to the next, sometimes even from one hour to the next? Are quasars powered by a rapid succession of supernova outbursts in a central core, or is it more likely that matter falling onto a single, central black hole supplies all the energy?

To clear up many of these questions, we need the full complement of our most powerful observatories, often working together to trace outbursts as they evolve—sometimes emitting successively in different wavelength bands, sometimes simultaneously varying across the entire spectrum.

These detailed observations should clarify the nature of the central engines powering quasars and explain the structure of ambient regions.

QUASARS ARE THE MOST POWERFUL KNOWN ENERGY SOURCES IN THE UNIVERSE. HOW DO THEY GENERATE SO MUCH ENERGY?

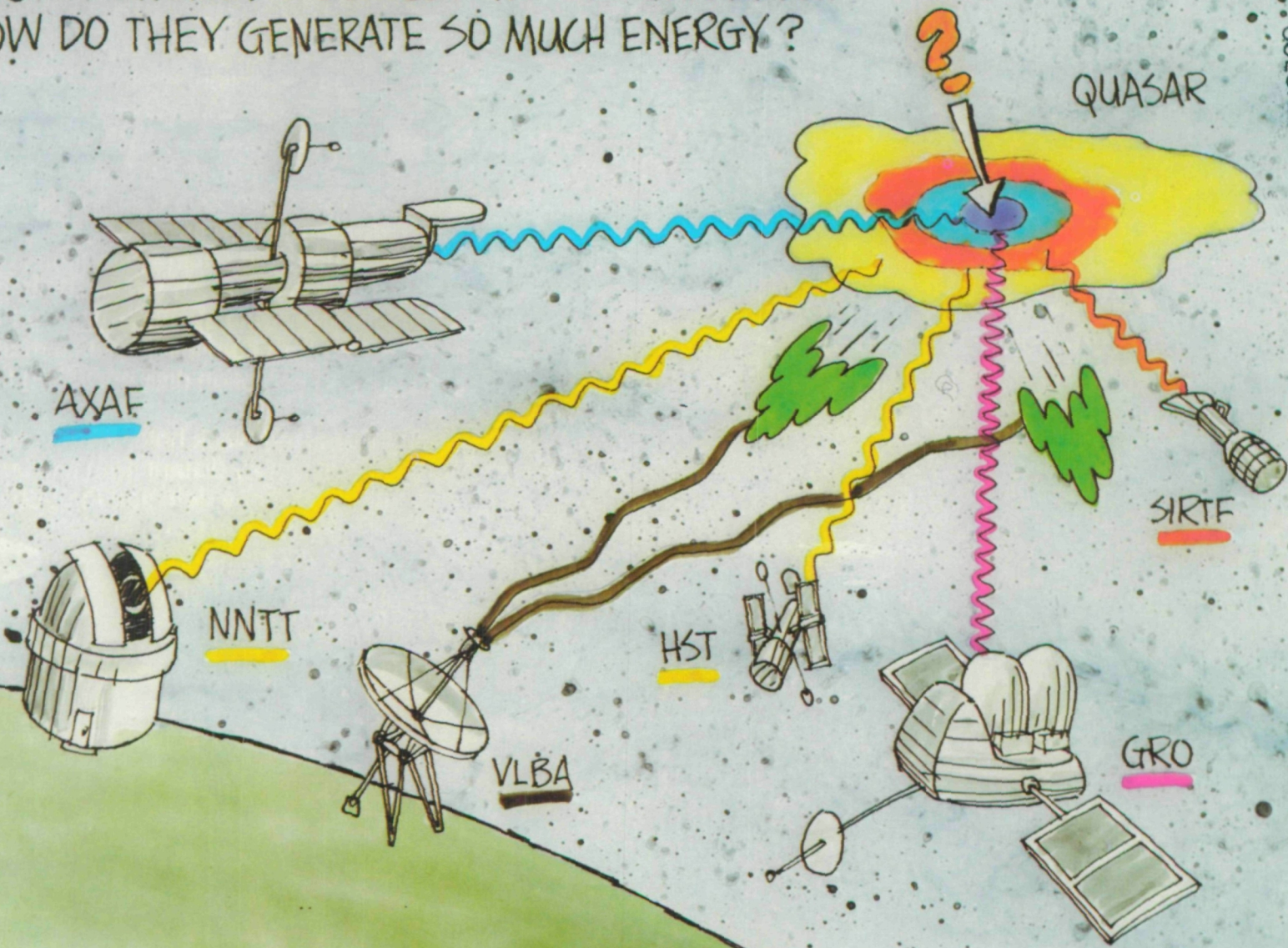

ORIGINAL PAGE
COLOR PHOTOGRAPH

ORIGINAL PAGE
COLOR PHOTOGRAPH

Black Holes

32

Black holes are enormously compact bodies, so dense that matter falls into them under an irresistible gravitational pull. So far we are not sure whether nature produces such holes. If they do exist, black holes could be very massive, or quite small, or just about as massive as a star.

The largest black holes might be the power sources for quasars; each could have a mass comparable to that of an entire galaxy of a hundred billion stars.

The smallest black holes could have masses of only a billion tons – roughly the mass of the Rock of Gibraltar – and could be capable of exploding at any time, annihilating themselves totally in an enormous flash of gamma radiation lasting no more than a few seconds.

A stellar-sized black hole could have a mass five or ten times greater than the sun's. Such a black hole in a binary system with a giant star could syphon matter off the giant's surface, giving rise to X-ray emission as this matter crashed down onto an accretion disk encircling the black hole.

A different stellar-sized black hole, also a member of a binary system but sufficiently distant from its companion star to leave it intact, might be detected through careful observations of the companion's orbital motion. The companion would appear to be circling a massive center, but there would be no radiation coming from that point; it would seem as though nothing were there except a strong gravitational pull, a black hole.

We are not yet sure that we have observed any one of these, but we know of likely candidates that need to be studied with the most powerful observatories we can build.

WHAT ARE BLACK HOLES? DO THEY REALLY EXIST?

- BLACK HOLES MAY EXIST WITH DIFFERENT MASSES AND DIFFERENT SIGNATURES:

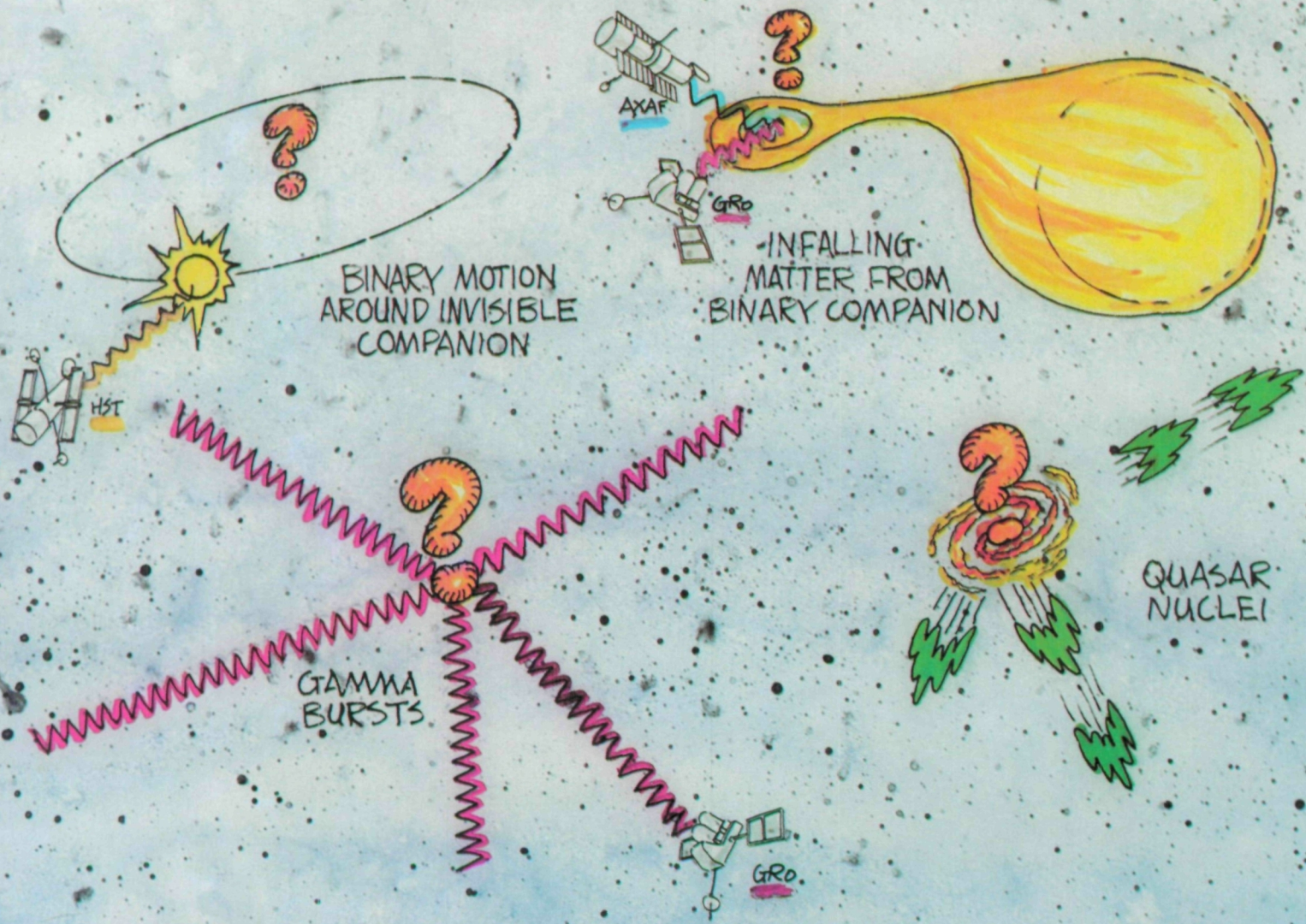

ORIGINAL PAGE
GOLDEN PHOTOGRAPH

Magnetic Energy Storage

34

Magnetic fields – on the surface of the sun, in interplanetary space, in far-reaching stellar jets, in interstellar clouds, in the spiral arms of galaxies, and in the giant intergalactic jets spanning an entire cluster of galaxies – are able to store enormous amounts of energy. Sometimes the stored energy is released in an explosive flare, through processes we do not understand at all. In fact, we have no convincing theories to explain the generation and existence of such strong magnetic fields.

To gain greater understanding, we must not only look beyond the solar system but also observe more carefully within it, looking at magnetic processes occurring in the interplanetary medium and magnetic events taking place on the sun's surface. The Solar Optical Telescope (SOT) will help us to understand solar magnetic events, interplanetary probes will help us to understand transformations in the magnetized interplanetary plasma, and our other observatories should enable us to relate these local effects to phenomena taking place on galactic and intergalactic scales.

MAGNETIC FIELDS EXIST IN OBJECTS OF DIFFERENT SIZES THROUGHOUT THE UNIVERSE. WHAT ARE THEIR EFFECTS?

- THIS IS A PROBLEM ON WHICH WE EXPECT TO MAKE PROGRESS NOT JUST THROUGH DIRECT COSMIC OBSERVATIONS, BUT ALSO BY USING SOLAR AND INTERPLANETARY DATA.

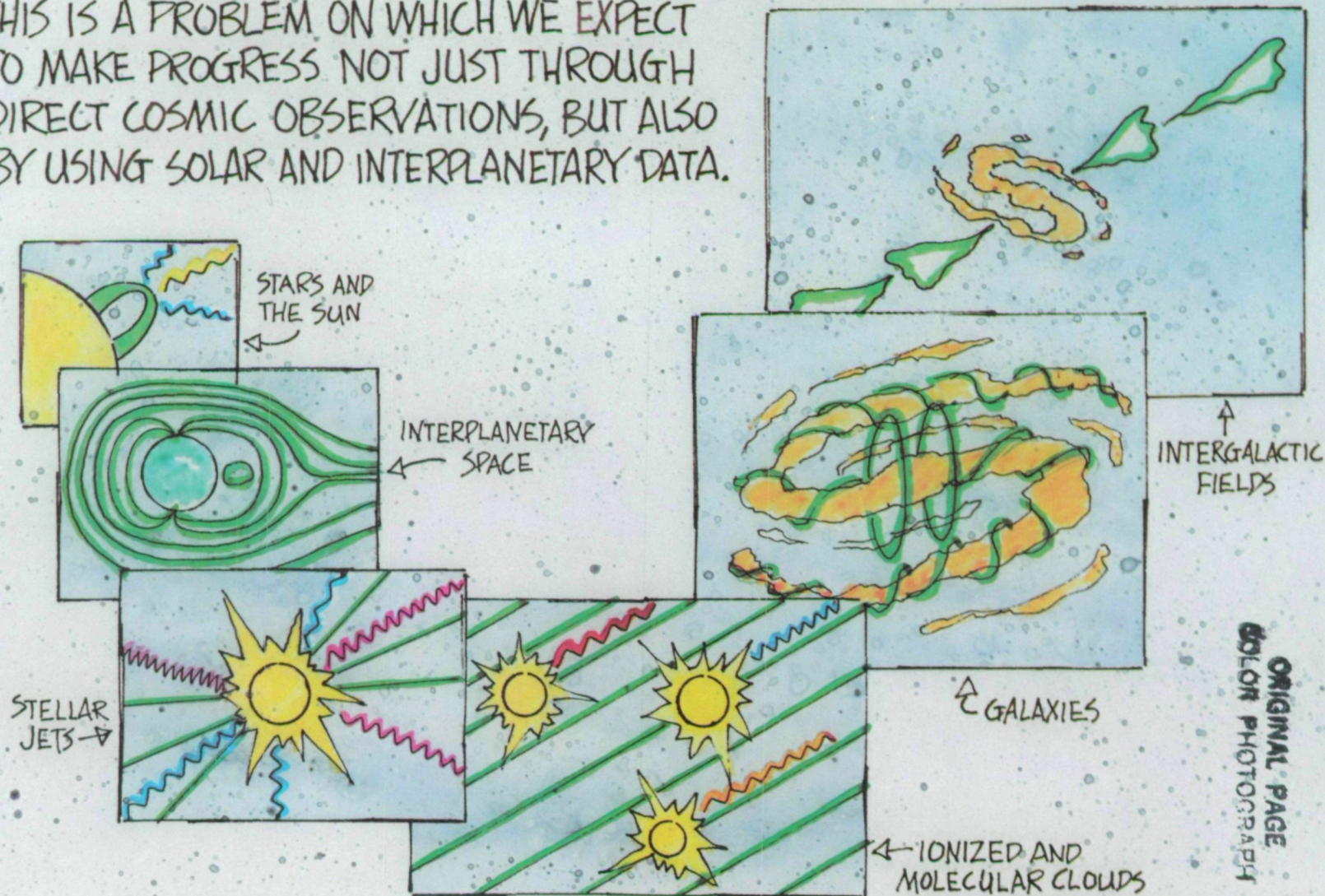

ORIGINAL PAGE
COLOR PHOTOGRAPH

Invisible Mass

36

Most of the matter in the Universe is known to us only through the gravitational forces it exerts on stars, galaxies and other visible sources, whose orbital motions we can follow. We have no adequate explanation for this invisible mass, which has given rise to one of the most troubling questions in astrophysics: what is it?

One suggestion is that most galaxies may have a faint halo of low-luminosity stars. These could be traced with an optical telescope like HST placed above the Earth's atmosphere and therefore capable of seeing fainter diffuse distributions of stars. The matter might also be distributed in galactic halos in the form of brown dwarfs, bodies intermediate in mass, between Jupiter-sized objects and the least massive stars known to emit visible light. Brown dwarfs would emit primarily at infrared wavelengths and be observed with SIRTf. A further possibility is a halo of black holes or of low-mass stars. In either case, a faint diffuse glow of X-rays would emanate from the halos of galaxies, a glow that AXAF would permit us to detect.

An entirely different tracer of invisible mass in clusters of galaxies is intensely hot intergalactic plasma. X-ray emission from this plasma is brightest in the innermost portions of the cluster where most of the mass is concentrated. The distribution of X-ray brightness across the cluster provides us with a measure of total mass. Using this measure, AXAF would permit us to search for invisible mass in clusters at extreme distances across the Universe.

Finally, families of new, exotic particles, like axions or gravitinos, or else networks of massive cosmic strings required by some elementary particle theories, could be responsible for this invisible mass. Further study may permit us to distinguish among these different kinds of particles and provide insight into fundamental forces that govern their interactions.

90% OF THE MATTER IN THE UNIVERSE IS INVISIBLE.
WHAT IS IT?

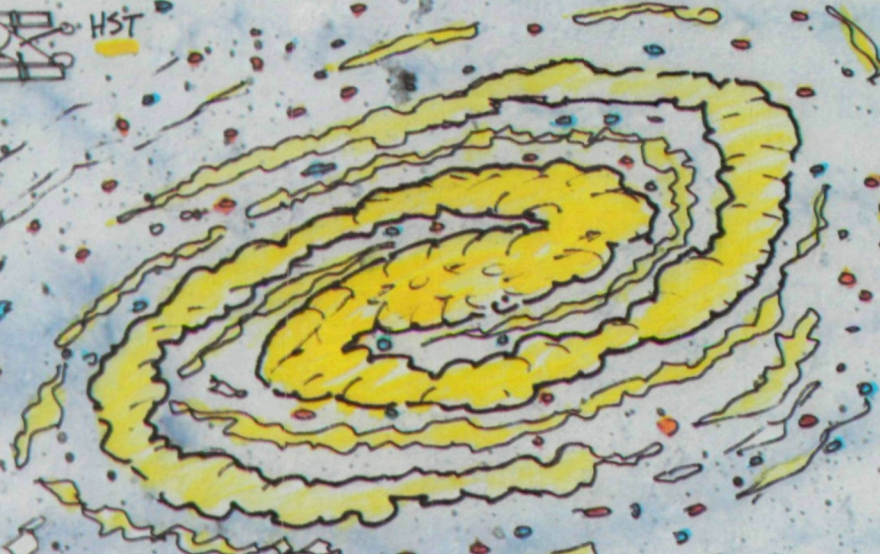
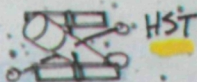

EXTENDED GALACTIC HALO



HOT INTERGALACTIC PLASMA
IN DISTANT CLUSTERS
OF GALAXIES.

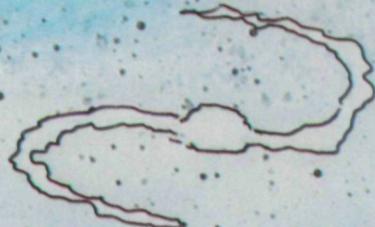

Looking Out into the Universe Means Looking Back in Time

38

The Universe is so large that even signals travelling at the greatest speed that can be attained – the speed of light – require billions of years to cross major portions of the tracts we can survey. This long delay in the arrival of radiation can work to our advantage.

To understand how galaxies or quasars originated in a rapidly expanding Universe, we can look back in time to observe the contraction of protogalactic clouds, expected to emit far-infrared radiation, and young galaxies emitting radiation at visible and infrared wavelengths. Young quasars should be powerful sources of X-rays as well as radio waves.

These sources are beyond the range of present instruments, but those limits will be surpassed with the next generation of space observatories capable of surveying the sky out toward the moment when galaxies began to form, and beyond, to the impenetrable barrier that lies at a distance and time when electrons and protons were combining to form atoms of hydrogen. Currently, only radio telescopes can look back at that barrier from which the cosmic microwave background radiation emanates. Some day we may devise ways of looking even further back, but that may have to await the construction of gravitational wave detectors or neutrino observatories.

LOOKING BACK IN TIME

TO UNDERSTAND HOW QUASARS AND GALAXIES FORMED, WE NEED TO LOOK FURTHER OUT INTO THE UNIVERSE TO OBSERVE EARLIER EPOCHS.

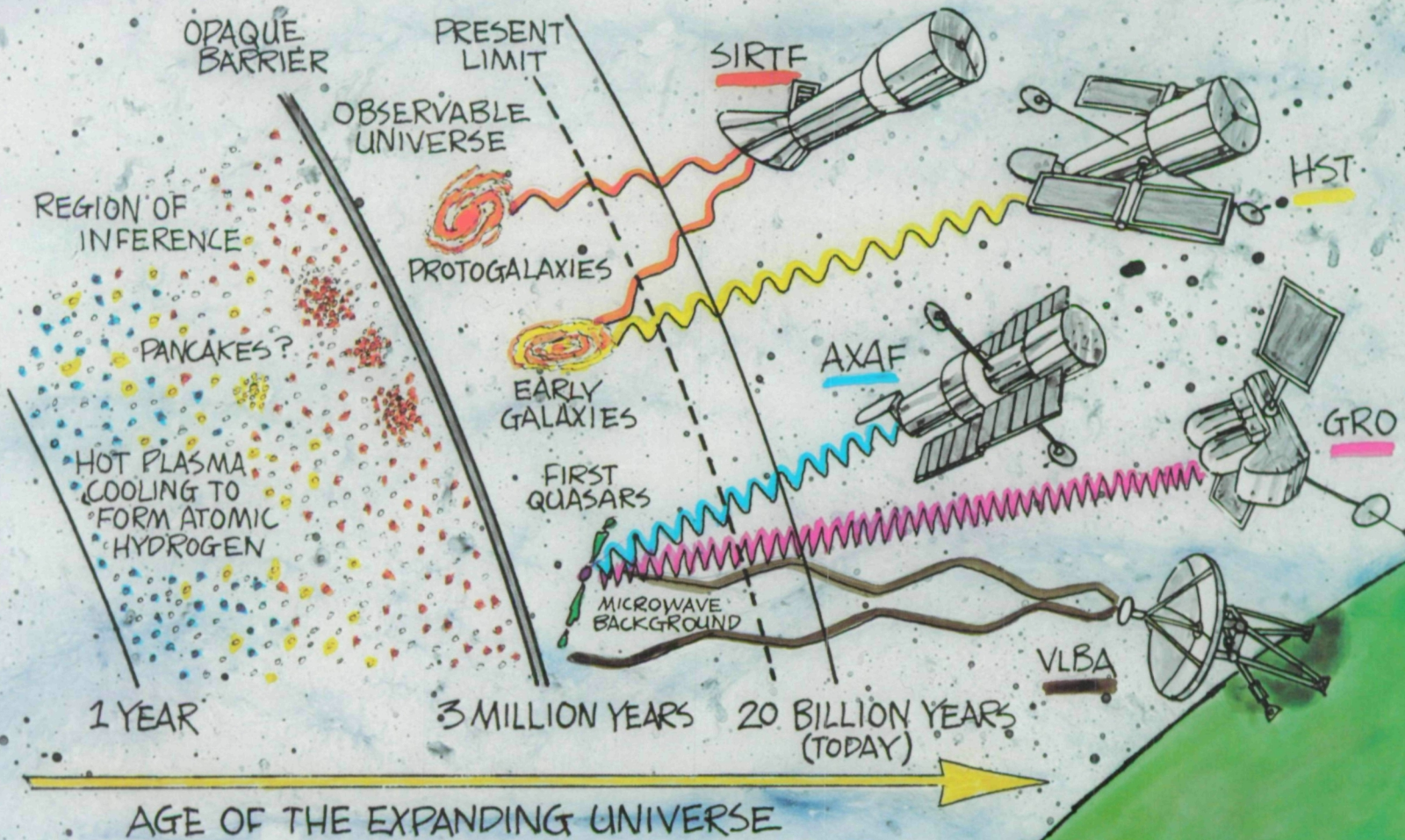

What is the Geometry of the Universe?

40

On Earth, distant objects appear small; their angular diameters diminish as they recede. In a curved, expanding Universe all that is changed.

Distances across the Universe can be gauged by the extent to which radiation reaching us is shifted toward longer wavelengths – the extent to which it is red shifted. The more distant the emitting source, the greater is the red shift.

In a closed Universe, the angular diameter of a galaxy or quasar observed at ever-increasing red shift – distance – first shrinks but then expands.

In an extreme open Universe, the angular diameter at first also declines but then slowly approaches a constant value at increasing red shift.

With AXAF we will be able to locate the most distant quasars in the Universe, and with HST we will determine red shifts and diameters of the most distant galaxies and quasars to investigate whether our Universe is open and expanding forever, or closed and bound to collapse on itself billions of years from now.

WHAT IS THE GEOMETRY OF THE UNIVERSE?
IS IT CURVED?
IS IT OPEN OR CLOSED?

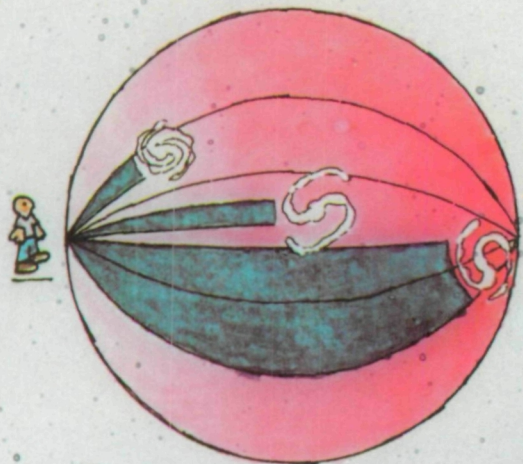

CLOSED COSMOS

OPEN COSMOS

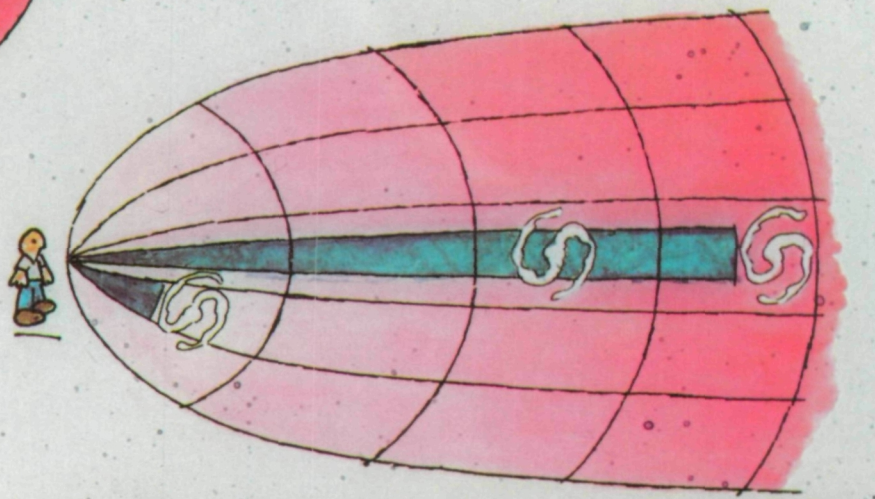

INCREASING RED SHIFT

~~ORIGINAL PAGE~~
~~COLOR PHOTOGRAPH~~

~~ORIGINAL PAGE~~
~~COLOR PHOTOGRAPH~~

~~ORIGINAL PAGE~~
~~COLOR PHOTOGRAPH~~

ORIGINAL PAGE
COLOR PHOTOGRAPH

Matter and Antimatter in the Universe

42

Much of the Universe we observe consists of hydrogen with an admixture of helium and heavier elements. However, everything we know about the Universe suggests that an equal amount of matter and antimatter –antihydrogen, antihelium and heavier antielements –should have existed at one time.

We can search for traces of antimatter, because we know that matter and antimatter annihilate on contact. If there existed distant galaxies composed entirely of antimatter, we should be able to detect the gamma radiation emitted when gas ejected from such a galaxy encountered and annihilated ordinary matter from a galaxy like ours.

If substantial amounts of matter and antimatter existed at earlier epochs, before galaxies ever formed, remnants of this annihilation radiation might still persist, red shifted but observable at gamma-ray and X-ray wavelengths.

DID THE UNIVERSE ONCE CONTAIN EQUAL AMOUNTS
OF MATTER (M) AND ANTIMATTER (A)? COULD IT STILL?

- WE NEED TO SEARCH FOR GAMMA AND X-RAY EVIDENCE FOR ANNIHILATION.
- WITH THE NEXT GENERATION OF COSMIC RAY INSTRUMENTS WE WILL ALSO BE ABLE TO CONDUCT ANTI-PROTON AND OTHER ANTIMATTER SEARCHES.

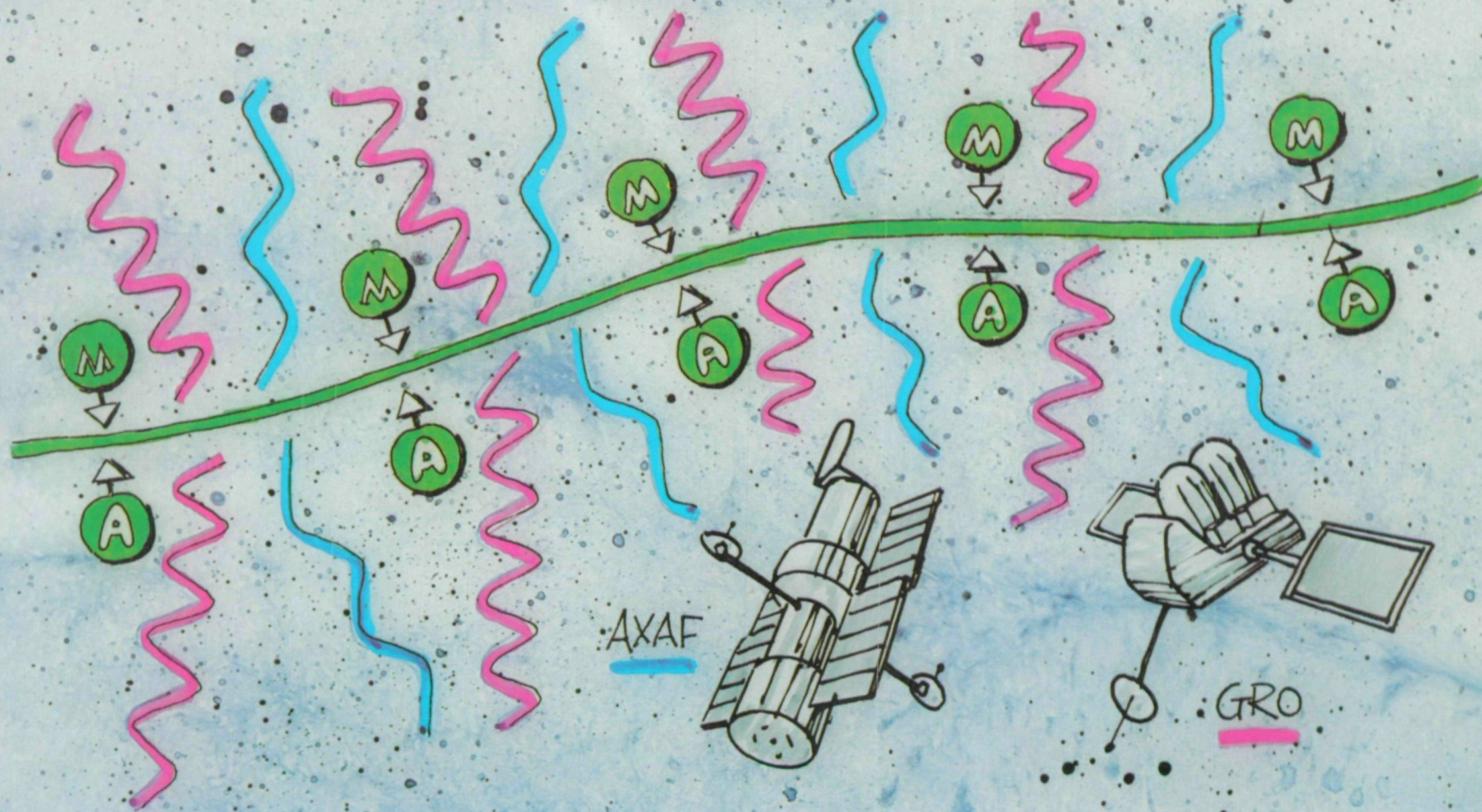

The Search for Other Planetary Systems

44

Analysis of data from the Infrared Astronomical Satellite (IRAS) has shown disks of warm rocks and pebbles orbiting several stars. Such a protoplanetary disk might be a precursor of a planetary system or might co-exist with a system of planets like ours. By studying the planets of our own solar system, we should be able to gain increasing insight into how planets elsewhere might be formed and how we might best search for planets around other stars.

Distant planets will be detected most readily through infrared radiation, since planets are too cool to emit visible light, and stars are often less bright at infrared than at visible wavelengths. A visible spectrum of a planetary system mainly will register stellar emission and reflect the chemical composition of the star. An infrared spectrum will show planetary contributions to the system's emission and could provide evidence for molecules, like methane, found on planets in our solar system but destroyed on the hot surface of a star like the sun.

SIRTF will be able to search for planets around the nearest stars. Spectra for any planets detected could tell us the chemical composition of the atmosphere and help us determine whether it might sustain life similar to that on Earth. Once planets are detected, a Search for Extraterrestrial Intelligence (SETI) would become more focused.

WE HAVE SOME EVIDENCE THAT PLANETS EXIST AROUND OTHER STARS.
HOW COMMON ARE PLANETARY SYSTEMS IN OUR GALAXY?

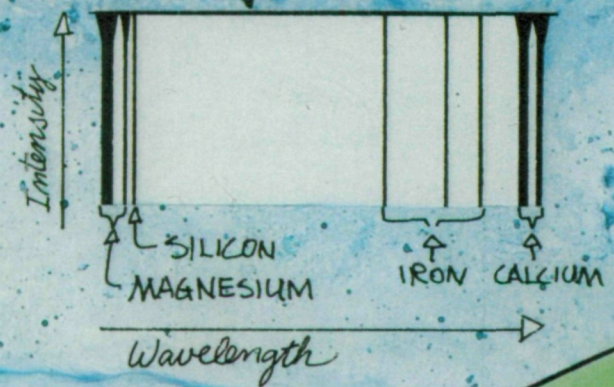
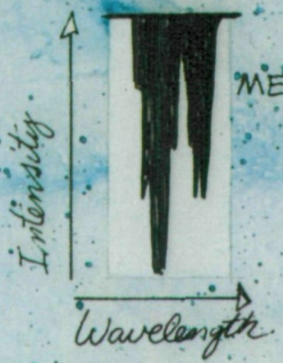
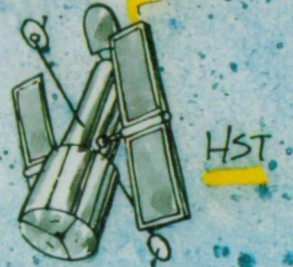
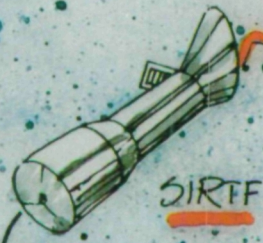
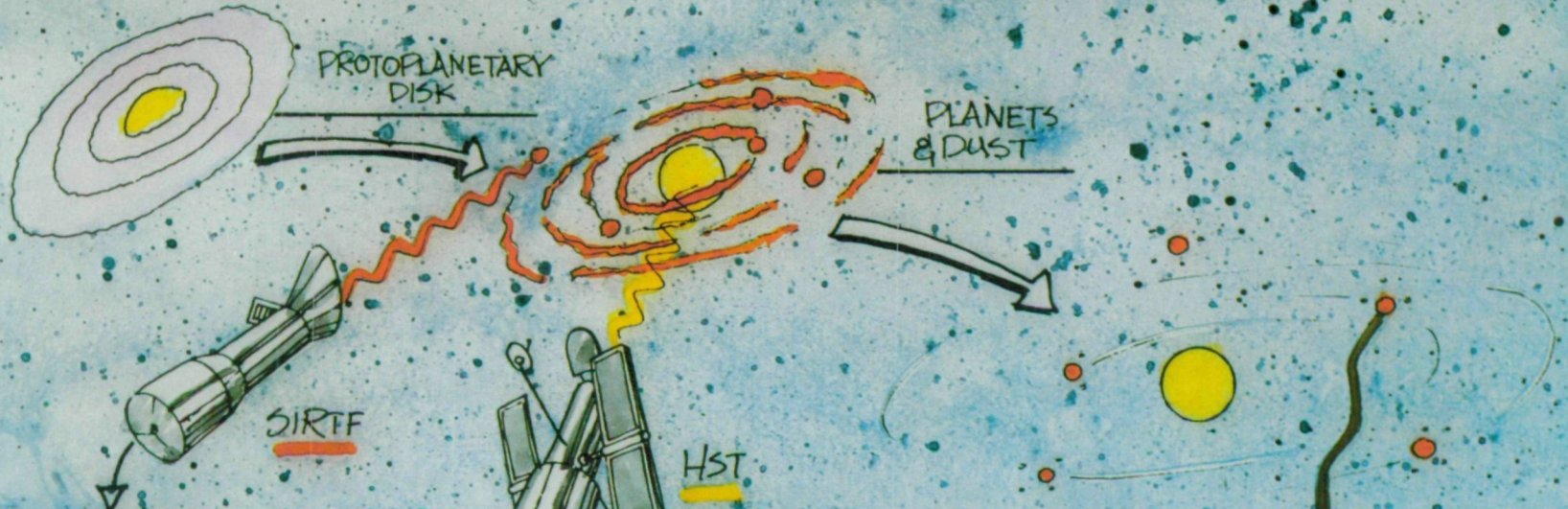

Is Life on Earth Unique?

46

The Earth is an insignificant companion of our sun, an unremarkable star: there are a thousand billion, billion stars just like the sun all over the Universe. Can we reasonably expect life to be unique here on Earth?

There is no scientific basis on which that question can be answered today. However, the search for other planets may help us locate other solar systems in which we could pursue our quest for extraterrestrial life. Primitive life forms are likely to remain undetectable for a long time to come; but technologically advanced civilizations could be identified by artificial signals they generate.

We know that stray television and FM broadcast signals radiated into space from Earth could be picked up by powerful radio observatories if they existed in the vicinity of nearby stars. Similarly, highly sensitive receivers on Earth might detect comparable signs of technological expertise around other stars in nearby parts of the Milky Way. The only question that would then remain is how we could be sure that such signals were artificial rather than generated by some previously unidentified natural phenomenon.

IS INTELLIGENT LIFE COMMON ELSEWHERE IN THE UNIVERSE?

- WE HAVE NO CLUES, BUT WE ARE SEARCHING FOR UNUSUAL SIGNALS, DIFFERENT FROM THOSE EMITTED BY ASTROPHYSICAL OBJECTS.

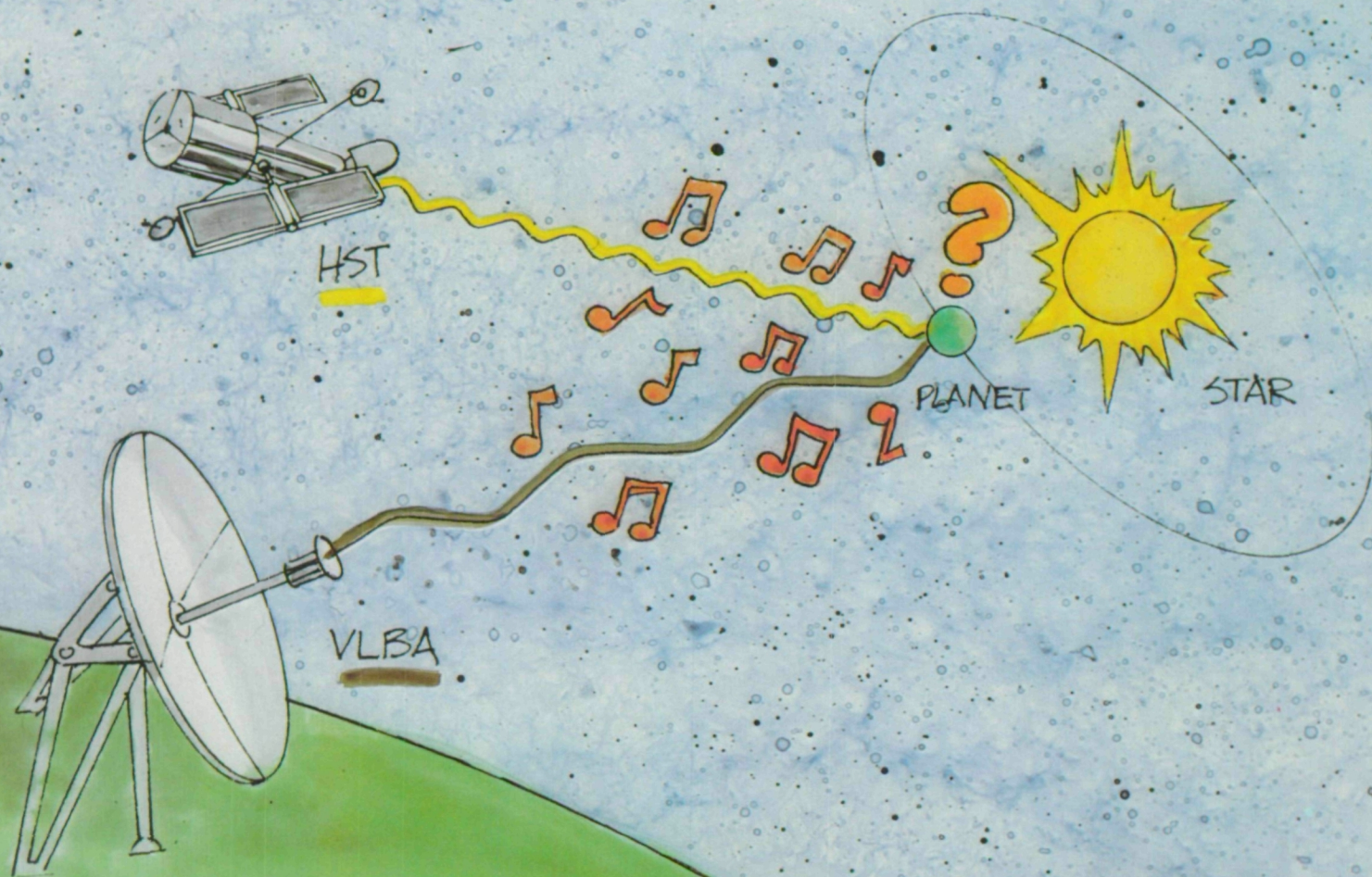

Epilogue

48

Astronomical searches have occupied human thought for millennia. Over the generations, we have succeeded in gaining ever greater insight into the underlying forces at work in the cosmos. In the Space Station era, the family of permanent observatories in space will open the way to new, comprehensive studies of key remaining problems in astrophysics, helping us understand:

- ☆ The birth of the Universe, its large-scale structure, and the formation of galaxies and clusters of galaxies;
- ☆ The fundamental laws of physics governing cosmic processes and events;
- ☆ The origin and evolution of stars, planetary systems, life and intelligence.

If we succeed, we will leave a legacy to rank us with the great civilizations of the past.

SPACE OBSERVATORIES

A PERMANENT PRESENCE

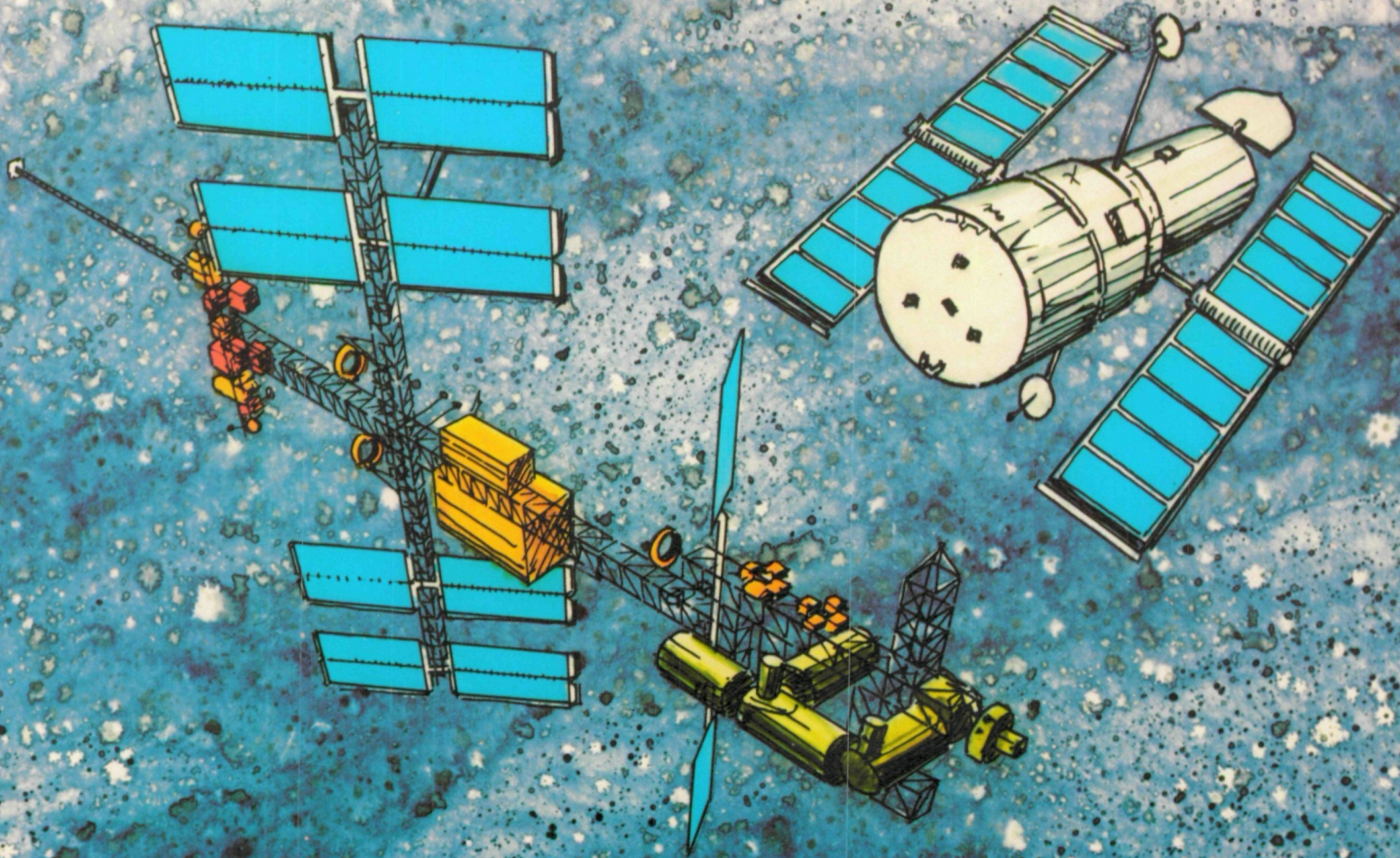

Prepared under the auspices of
The NASA Astrophysics Division,
Dr. Charles J. Pellerin, Jr., Director
by
Dr. Martin Harwit, Cornell University
and
Dr. Valerie Neal, Essex Corporation
in consultation with the
Astrophysics Management Operations Working Group

Graphic design and illustration by Brien O'Brien



National Aeronautics and
Space Administration

Astrophysics Division

21M585