

N86 - 28414

ELECTRODYNAMIC INTERACTIONS

Marino Dobrowolny
Istituto Fisica Spazio Interplanetario CNR

PRECEDING PAGE BLANK NOT FILMED

I will give a general introduction on the electrodynamic interaction of long metallic tethers with the ionosphere. Although I will not get into any detail, this will serve as a basis for J. McCoy's presentation on the use of electrodynamic tethers for power generation and thrust.

Figure 1 shows the basic concept of electrodynamic tethers. It refers explicitly the TSS but, of course, the concept is more general. Due to the tether's motion across the Earth's field, we have a polarization electric field along the tether. For an observer at rest in the ionosphere, this is given by

$$\underline{E} = -\underline{V} \times \underline{B}$$

and is so directed that the upper end of the system is positive with respect to the lower end. For this reason, in a system like TSS where the tether is coated with dielectric and the electrical contact is between its two terminations and the ionosphere, the upper end termination will collect electrons and, in a passive system, the lower end will collect ions. Alternatively, with a plasma emitter or electron gun at the lower end, the electrons collected above will be re-emitted in the ionosphere.

For the tether of TSS 1, the voltage across the tether amounts to a maximum value

$$V_{\max} \sim 5K \text{ volts}$$

and, of course, varies along the orbit. In general, space charge regions will develop around the two terminations of the system, which can be at considerable potential with respect to the unperturbed ionospheric plasma and the current in the tether will be most significantly determined by local processes in such space charge regions.

Our knowledge of the behavior of highly charged bodies in a flowing plasma in a magnetic field is indeed quite limited, both theoretically and from the laboratory point of view, and the investigation of such local processes is certainly the primary goal of the first TSS electrodynamic mission.

Having pointed out the importance of these local processes, let me now outline a qualitative view of the global perturbation induced by TSS in the ionosphere (see Figure 2). An observer sitting on the tether will see a dc current in the tether itself going out into the ionosphere along the magnetic flux tubes intercepted by its two terminations. The current, as indicated in the figure, is assumed to go away along such magnetic flux tubes until it reaches an altitude low enough that conductivity transverse to magnetic field lines becomes appreciable and allows current closure across the ionosphere.

The picture is different for an observer in the ionosphere or on the Earth's surface. At a certain time the tether will apply a voltage between the flux tubes intercepted by its two terminations at that time. The voltage pulse will last a time

$$T \sim \frac{D}{V}$$

where V is the system velocity and D is one dimension transverse to the motion. As the charge separation set up by the tether, at that given time cannot be discharged across magnetic field lines, it will rather be propagated as a pulse in the ionosphere. The duration of the pulse also sets up the upper limiting frequency

$$f^* \sim \frac{1}{T}$$

of the electromagnetic radiation caused by the tether's motion. If we use for D the diameter of the TSS satellite ($D = 1.2\text{m}$) we obtain $f^* \sim 7 \text{ kHz}$ so that the perturbation will include not only low frequency EM waves

but will extend in the whistler range. One of the interesting applications of electrodynamic tethers, as you all know, is that of using them as low frequency wave generators to communicate to the Earth at ELF/ULF. There are theoretical investigations of the power emitted by long tethers at these low frequencies which give the indication of low powers in the ionosphere (typically 1 watt for 1 ampere and 100 km tether). Such investigations are, however, based on very simplified models, and the truth is that we have not been able so far to adequately describe the phenomenon. Ground observations of TSS radiation are indeed foreseen in conjunction with the first TSS flight, and perhaps will give some positive indication of the phenomenon. For the understanding of the global perturbation associated with electrodynamic tethers, it would, however, be essential to have ionospheric measurements from a free flyer at variable distances from the tether system and on magnetic flux tubes intercepted by the tether.

Based on what I have said about local interaction processes and the global interaction with the ionosphere, let me now describe an equivalent circuit of the tether system (see Figure 3). Here Z_E represents the impedance of the current closure in the ionospheric E layer. Z_{TR} represents the impedance of the magnetic flux tubes intercepted by the two terminations of the system which act as transmission lines in the ionosphere. Z_{ORB} and Z_{SAT} represent the impedances of the space charge regions around the orbit and the satellite, for the case of TSS, or in any case, around the two conducting terminations of any tether system. In terms of what I have said before, Z_{TR} represents the effect of the tether's radiation or, if you like, the global perturbation induced by the moving tether in the ionosphere. On the other hand, Z_{ORB} and Z_{SAT} represent the local interaction processes determining charged particle collection.

In this same figure I have also written the basic equation of the circuit. What is written is, more precisely, that the total voltage drop

across the tether ($\Delta V = VBL - RI$) which is given by the electromotive force due to the motion minus the ohmic losses due to the tether's internal resistance, equals the sum of all the remaining potential drops in the circuit

$$\Delta V = VBL - RI = \Delta\phi_{ORB} + \Delta\phi_{SAT} + \Delta\phi_I$$

Of these, $\Delta\phi_I$ is the total potential drop across the ionosphere and hence represents the magnitude of the pulse which is really applied to the ionosphere. On the other hand, $\Delta\phi_{ORB}$ and $\Delta\phi_{SAT}$ represent the potential drops across the space charge regions around the two terminations of the system. The problem with this equation is that $\Delta\phi_{ORB}$ and $\Delta\phi_{SAT}$ are complex nonlinear and unknown functions of the current in the tether.

These are the results of the local interactions that I was talking about before. We also see clearly from this equation that global and local interactions are part of the same picture and, for example, until the current voltage characteristics are determined, we cannot tell how much of the perturbation is applied to the ionosphere. It is also clear from the same equation that, in order to have maximum current in the tether, we have to reduce as much as possible $\Delta\phi_{ORB}$ and $\Delta\phi_{SAT}$, i.e., improve the electrical contact between the two terminations of the system and the ionosphere. This is indeed the situation one should aim at for the purpose of such applications as power generation and thrust.

BASIC CONCEPT OF ELECTRODYNAMIC TETHER

$$\underline{E} = -\underline{V} \times \underline{B}$$

$$\Delta\Phi \text{ MAX} \sim 5\text{Kv (TSS1)}$$

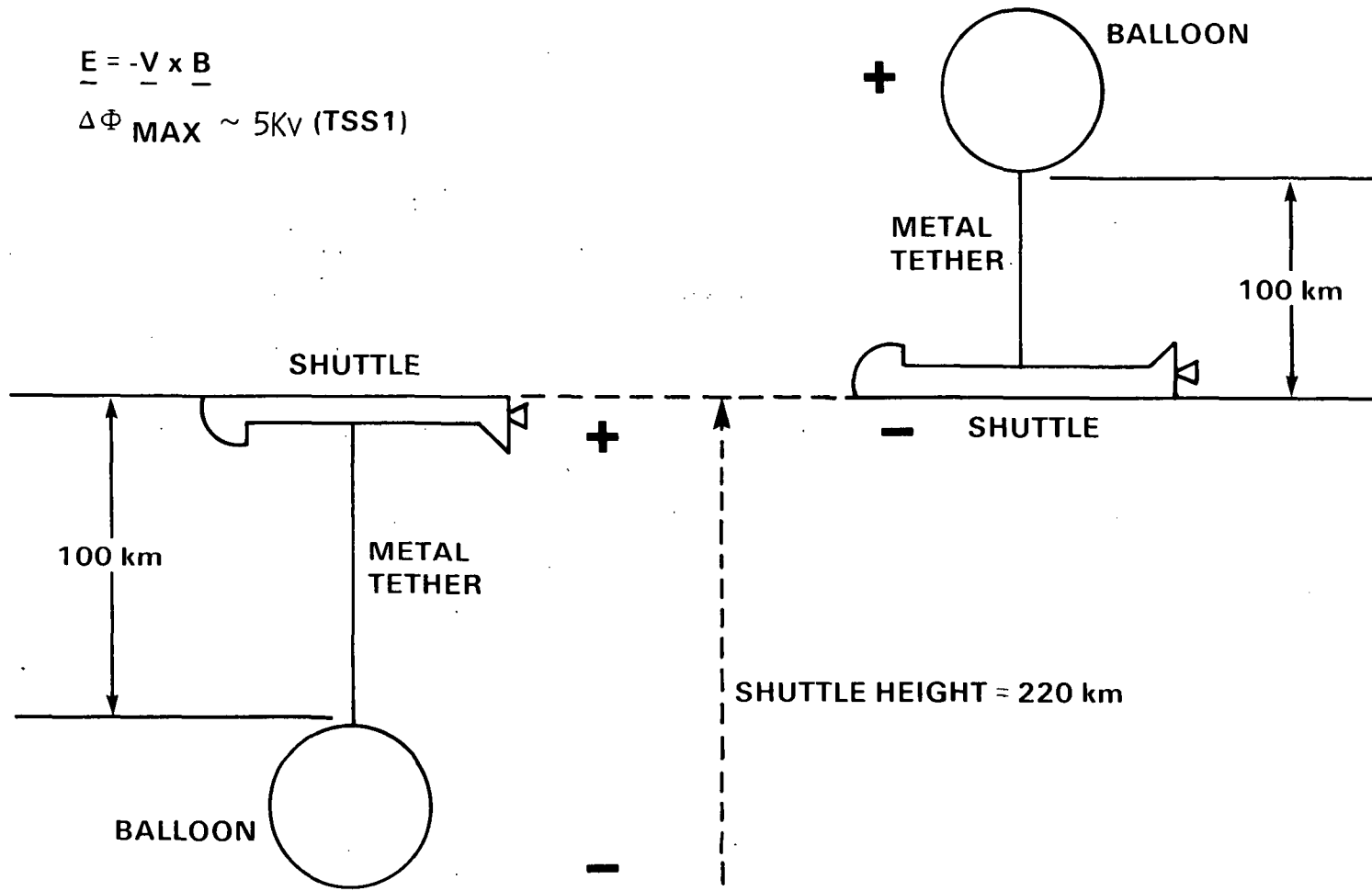
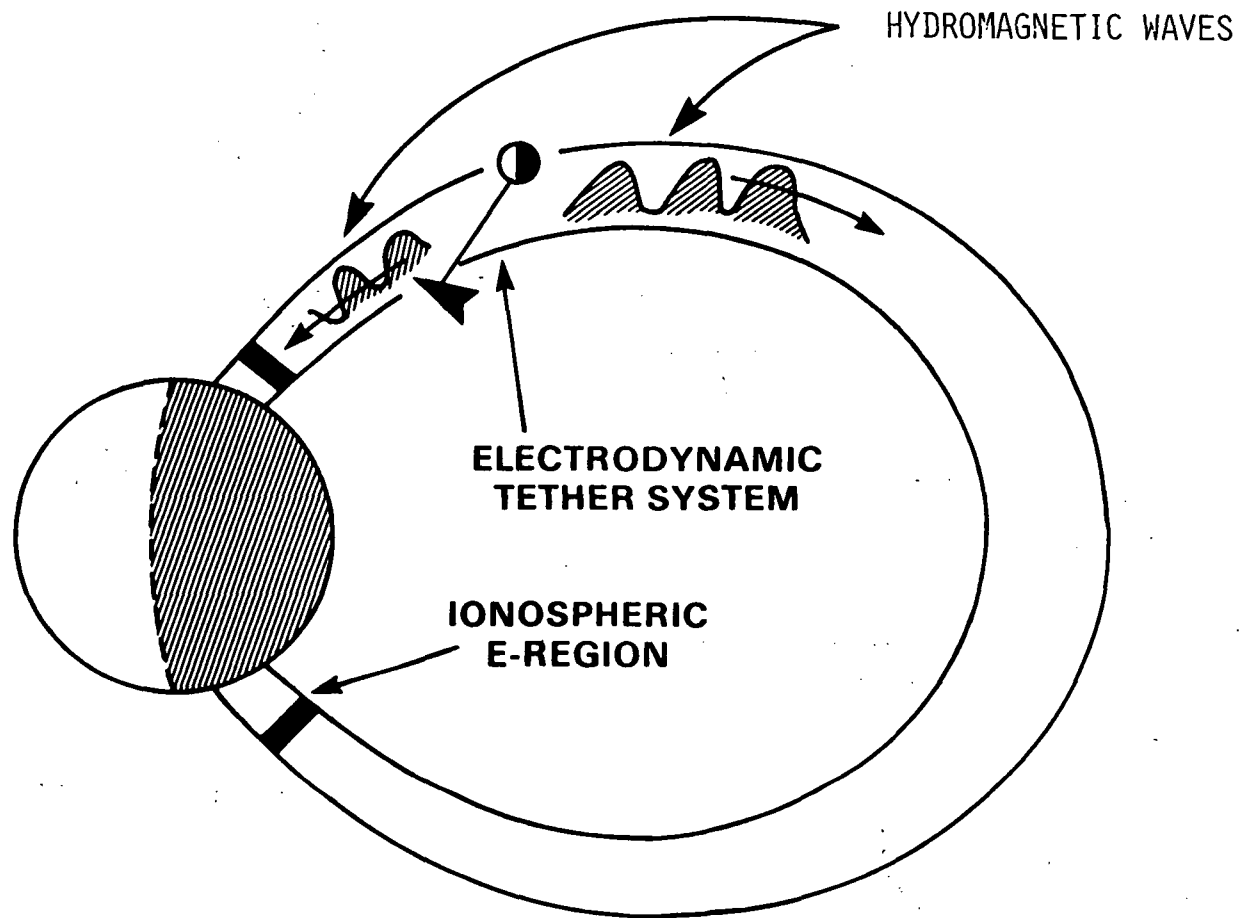

FIGURE-1

CONFIGURATION A

CONFIGURATION B

GLOBAL IONOSPHERIC PERTURBATION INDUCED BY ELECTRODYNAMIC TETHER



159

$$T \sim \frac{D}{V}$$

$$f < f^* \sim \frac{1}{T}$$

FIGURE-2

CIRCUIT EQUIVALENT OF ELECTRODYNAMIC TETHER

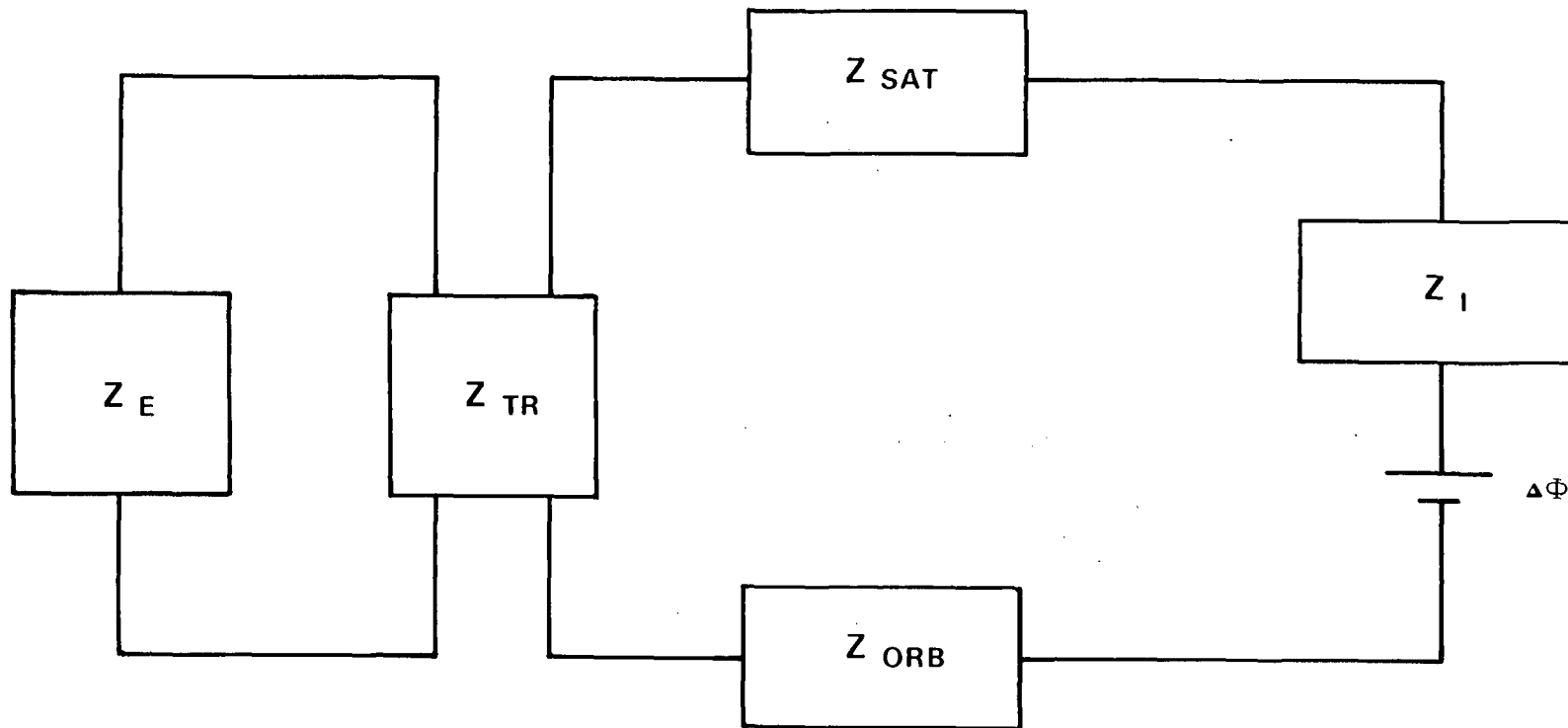

$$\Delta\Phi \equiv VBL-RI = \Delta\Phi_I + \Delta\Phi_{ORB} + \Delta\Phi_{SAT}$$

FIGURE-3