

N86 - 28421

TETHERED CONSTELLATIONS

Enrico Lorenzini
Smithsonian Astrophysical Observatory

PRECEDING PAGE BLANK NOT FILMED

First Day Presentation at the Venice Workshop

Tethered Constellations

Speaker: Dr. E. Lorenzini, Smithsonian Astrophysical Observatory

This presentation briefly addresses the studies that have been carried out so far on Tethered Constellations since the last Tether Workshop in Williamsburg, Virginia in 1983.

A definition of "tethered constellation" is required since there is sometimes a great deal of misunderstanding. A tethered constellation is any number of masses/platforms greater than two connected by tethers in a stable configuration.

Viewgraph #1

In general we can have 1-D, 2-D and 3-D constellations. In order to design a passively stabilized tethered constellation we must resort to every non-negligible force or gradient that is available in low orbit. The vertical gravity gradient is the strongest of all but there are also differential air drag, electrodynamic forces, J_{22} gravity components and others. A combination of the above mentioned forces can be exploited in order to provide a stable configuration.

Viewgraph #2

The study plan on tethered constellations was very well defined by NASA at the workshop in Williamsburg: tethered constellations were divided in two

different categories. On the right side of the figure there are the so-called "dynamic constellations." The adjective "dynamic" is not completely appropriate, however their name means that a tethered constellation is rotating with respect to the orbiting reference frame. On the left side of the same figure there are the "steady state constellations." Again the adjective "steady state" is somewhat misleading because these constellations rotate at orbital rate so that "steady state" must be intended with respect to the orbiting reference frame. In this category there are 1-D, vertical constellations like the one on the far left of the figure; the so-called "fish-bone" constellations, in the center of the figure and the 1-D, horizontal constellations.

Viewgraph #3

Tethered constellations can be used for many different applications such as the micro-g/variable-g laboratory or the multi-probe laboratory where separate probes are distributed along a vertical tether in order to measure gradients of geophysical quantities. These two systems can be operated either by the Shuttle or by the Space Station. A possible strategy is to use the Shuttle for testing the system and the Space Station for the permanent facility. Another application of tethered constellations is the ULF/ELF phased antenna; namely three masses are on the tether and a current is flowing alternatively in the upper and lower tether in order to inject a square electromagnetic wave into the ionosphere. Beside the issues related to the detectability of the signal on the ground, this system requires an investigation of the constellation dynamics forced by the electrodynamic drag and thrust associated with the wave injection process.

The space elevator is an application studied by Aeritalia. A tether with an end mass/platform is attached to the Shuttle providing a rail for the motion

of the space elevator. The space elevator can be used to transport materials to and from the end mass that in this case is a storage area. The space elevator, when operated near the orbit center of the entire system (zero acceleration point) can be used as a micro-g/variable-g laboratory.

With reference to the Space Station, possible attachment points of tethers to the Space Station are in the upper deck and lower deck. If two tether systems (one up and one down) are operated simultaneously the resulting configuration is a tethered constellation.

The last category of applications listed in the viewgraph is formed by free-flying tethered constellations; free-flying meaning that they are not attached to a mother station. An example are the 2-D constellations: four or more masses are kept in relative fixed positions by tethers in order to have a physical separation of activities within the same space vehicle.

Another idea, generated at the Smithsonian Astrophysical Observatory, is the variable baseline tethered interferometer. A tethered system with three masses rotates on a plane perpendicular to the line of sight to the source. The two end masses carry the mirrors while the interference fringes of the incoming signal are measured at the platform in the middle. By varying the tether length (variable baseline) a two-dimensional scanning of the source is performed.

In the area of the 2-D constellations, electrodynamically stabilized constellation can be used to provide an external stable frame for giant reflectors.

Viewgraph #4

This viewgraph summarizes the studies that have been performed on the various types of constellations. The major goal of the investigation was to

access feasibility of different configurations. Most of the studies were focused lately on the 1-D, vertical constellations which appear to be the most promising configurations.

Viewgraph #5

Some general comments on the stability of tethered constellations are shown in this viewgraph. 1-D, vertical constellations are definitely preferable from the stability point of view to 1-D, horizontal constellations: the vertical gravity gradient dominates the differential air drag at Space Station altitude while at lower altitude (150-200 km), where differential air drag can become relatively strong, the orbital lifetime is very limited. Regarding the 2-D constellations a convenient way for achieving a stable configuration is by exploiting the gravity gradient for overall attitude stability (constellation's minimum axis of inertia must be along the local vertical) while differential forces such as air drag or electrodynamic forces are used to stretch the constellation horizontally in order to provide shape stability.

Viewgraph #6

Stability constraints for the 1-D, horizontal constellations are shown in this viewgraph. The fundamental parameter is the differential ballistic coefficient of the two end bodies that in the case of a massive front body and a voluminous rear body (balloon) is equal to the ballistic coefficient of the latter. The table shows maximum tether lengths for static stability along the local horizon, and orbital decay rates. Results are strongly dependent on the atmospheric density conditions. By assuming a ballistic coefficient of $10 \text{ m}^2/\text{kg}$ for the rear balloon (twice as much the Echo balloon's ballistic coefficient), the table shows that tether lengths and orbital lifetimes are contrasting re-

quirements and they are never sufficiently satisfied in the altitude range of interest. In general it must be said that a passively stabilized horizontal constellation is justified by a long lifetime mission requirement whereas a constellation designed for a short lifetime can more easily use active stabilization.

Viewgraph #7

The "fish-bone" configuration was the first proposed 2-D constellation. A "fish-bone" constellation can be reduced to an equivalent 1-D, horizontal constellation if the overall ballistic coefficient of the rear leg (ballons + tethers) and the front leg are respectively concentrated at the end of the horizontal tether. Actually the stability of a "fish-bone" constellation is even more marginal than a comparable 1-D, horizontal constellation because a lower, rear (equivalent) ballistic coefficient is attainable in the "fish-bone" due to the greater complexity of the system.

Viewgraph #8

This viewgraph shows two of the alternative configurations for 2-D constellations that we have developed at SAO. Both of them use differential air drag for the shape stability while the gravity gradient provides the overall attitude stability only, in accordance with the comments expressed in viewgraph #5. They are therefore called drag stabilized constellations or DSC. Differently from the "fish-bone" constellations air drag and gravity gradient do not fight each other in a DSC.

Viewgraph #9

2-D configurations similar to those previously presented are shown in this viewgraph. The first one on the left is like the quadrangular DSC except that a current flowing in the outer loop provide the shape stability of the system. The current interacts with the earth magnetic field and it generates electrodynamic forces that, depending on the current direction, push the constellation perpendicularly to the local current like the air inside a balloon. They are called electrodynamic stabilized constellations or ESC. The configuration on the right uses the same principle with a different geometry. The outer loop is acted upon by distributed gravity gradient forces and distributed electrodynamic forces. The two lumped masses provide extra attitude stability without affecting the shape. The resulting shape is very similar to an ellipse apart from being more flat at the apices so that these constellations are called pseudo-elliptical constellations or PEC. PEC's can provide a stable external frame for a two-dimensional reflector or similar, in space.

Viewgraph #10

The studies on tethered constellations are now concentrating on the 1-D, vertical constellation with 3 masses for micro-g/variable-g applications (from now on called g-platform). The g-platform is operated from the Space Station whose mass, at the time this investigation started, was 90.6 metric tons. A 10 km tether is attached to the Space Station and ballasted at the end with a 9.06 metric ton mass. The center of the orbit (zero-g acceleration point) of the system is 1.2 m lower than the system c.m. The center of the orbit is the point where the micro-g laboratory is located for conducting micro-g experiments, whereas the laboratory will be moved up or down along the tether to perform variable-g experiments.

Viewgraph #11

In the effort to access what acceleration level is attainable with such a system, the constellation dynamics has been simulated over some orbits. Simulations are preliminary and perturbations such as transverse wire dynamics and Space Station orbital variations are not accounted for yet. Nevertheless this simulations give an idea of what order of magnitude for the acceleration has to be expected at the best of the system performance. In the simulations an acceleration level around $10^{-8}g$ has been attained; this value being primarily limited by the J_z component of the gravity field. The J_z component forces the system to librate and also directly and indirectly (through libration) stretches the tethers longitudinally. Longitudinal tether vibrations accounts for the behavior of the radial acceleration component shown in the figure. The low frequency variation is not abatable (being the steady state component) while the high frequency components can be damped out by appropriate longitudinal dampers (missing in the present simulation).

Viewgraph #12

Further studies on the g-platform have been carried out including the deployment of the system from the Space Station and the damping of longitudinal, librational and transverse (1st mode) vibrations. Successful deployment in less than 3.5 hours has already been demonstrated while appropriate damping algorithms have been devised.

Viewgraph #13

The conclusions are therefore as follows. The 1-D, horizontal, passively stabilized constellations have been ruled out on the basis of what pointed out

before. "Fish-bone" constellations have been similarly ruled out, whereas alternative, stable, 2-D configurations have been devised such as the ESC's, the DSC's and PEC's. Typical dimensions for these constellations are 10 km (horizontal) by 20 km (vertical) with balloon diameters around 100 m in the case of a DSC and a power consumption around 7 KW for an ESC or PEC.

Viewgraph #14

1-D, vertical constellations are very stable with a variety of different applications. A 3-mass system can be conveniently used as a micro-g/variable-g laboratory. Such a system shows promises of providing an acceleration level better than the $10^{-5}g$ level attainable on board the Space Station plus the additional, important option of having a variable/controlled g-level whenever desired.

1-D, vertical constellations with many masses along the tether can be used as a multi-probe system to collect simultaneous data at different locations along the local vertical. The capability of measuring geophysical gradients would be greatly enhanced by such a system.

Tethered constellations are showing many intriguing and unexpected capabilities: all the necessary ingredients are by now available and some of the options are already taking shape. Additional fantasy could transform this already numerous dishes into a tremendous menu.

SMITHSONIAN ASTROPHYSICAL OBSERVATORY
60 GARDEN STREET
CAMBRIDGE, MASSACHUSETTS 02138
U.S.A.

WORK DONE UNDER CONTRACTS:
NAS8-35497 NASA/MSEC
NAS8-36606 NASA/MSEC
RH4-394019 MMC

TETHERED CONSTELLATIONS IN SPACE

BY

ENRICO LORENZINI

PRESENTED TO:

APPLICATIONS OF TETHERS IN SPACE WORKSHOP
VENICE, ITALY
15-17 OCTOBER 1985



SMITHSONIAN ASTROPHYSICAL OBSERVATORY

GENERAL

- ANY GENERIC DISTRIBUTION OF MORE THAN TWO MASSES IN SPACE CONNECTED BY TETHERS IN A STABLE CONFIGURATION IS A TETHERED CONSTELLATION

- 1-D, 2-D, 3-D CONFIGURATIONS THEORETICALLY POSSIBLE

- STABILIZING FORCES CAN BE FOR EXAMPLE
 - VERTICAL GRAVITY GRADIENT
 - DIFFERENTIAL AIR DRAG
 - ELECTRODYNAMIC FORCES
 - J_{22} GRAVITY COMPONENT
 - CENTRIFUGAL FORCES

- A COMBINATION OF THE ABOVE MENTIONED FORCES CAN BE EXPLOITED IN SOME CONFIGURATIONS

CONSTELLATION STUDY PLAN

- STUDY PLAN INITIALLY DEFINED BY NASA APPLICATIONS OF TETHERS
IN SPACE WORKSHOP GROUP

- "DYNAMIC" CONSTELLATIONS HAVE NOT BEEN
PURSUED ON THE BASIS OF FEASIBILITY
CONSIDERATIONS

- STATIC CONSTELLATIONS HAVE BEEN
ANALYZED AS WELL AS ALTERNATIVE
CONFIGURATIONS

- MAJOR AREAS OF INVESTIGATION
 - CONFIGURATION STABILITY
 - STATION-KEEPING DYNAMICS
 - DEPLOYMENT STRATEGICS
 - MODAL VIBRATION DAMPING

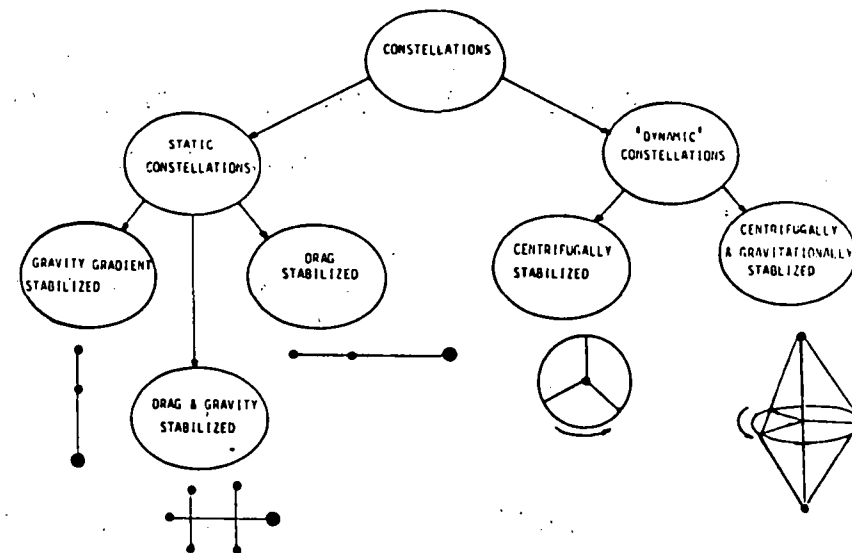

PRESENTLY PROPOSED APPLICATIONS FOR TETHERED CONSTELLATIONS

- ATTACHED TO THE SHUTTLE
 - MICRO-G/VARIABLE-G LAB: 1-D, 3-MASS
 - MULTI-PROBE LAB FOR MEASUREMENT OF GEOPHYSICAL GRADIENTS:
1-D, 4 OR MORE-MASS
 - TESTING OF ULF/ELF PHASED LONG ANTENNAE: 1-D, 3-MASS
 - SPACE ELEVATOR FOR TRANSPORTING MATERIALS TO THE END MASS: 1-D, 3-MASS
- ATTACHED TO THE SPACE STATION
 - MICRO-G/VARIABLE-G LAB: 1-D, 3-MASS
 - MULTI-PROBE LAB: 1-D, 3 OR MORE MASS
 - STORAGE OF MATERIALS/FLUIDS SERVICED BY THE SPACE ELEVATOR: 1-D, 3-MASS
 - DUAL DEPLOYER, ONE PER SIDE OF THE SS: 1-D, 3-MASS
- FREE-FLYING TETHERED CONSTELLATIONS
 - SEPARATION OF DIFFERENT ACTIVITIES IN A PHYSICALLY CONNECTED CLUSTER:
2-D, MULTI-MASS
 - OPTICAL INTERFEROMETRY: 1-D, 3-MASS, ROTATING
 - GIANT REFLECTORS IN SPACE: 2-D

TETHERED CONSTELLATIONS UNDER INVESTIGATION

- 1-D, HORIZONTAL CONSTELLATIONS
 - STABILITY ANALYSIS
- 2-D, "FISH-BONE" CONSTELLATIONS
 - STABILITY ANALYSIS
- 2-D, GENERIC CONSTELLATIONS
 - ALTERNATIVE CONFIGURATIONS
 - STABILITY ANALYSIS
- 1-D, 3-MASS VERTICAL CONSTELLATIONS
 - STATION-KEEPING DYNAMICS
 - DEPLOYMENT STRATEGY
 - MICRO-G APPLICATIONS
 - DAMPING OF MODAL VIBRATIONS

GENERAL COMMENTS ON CONSTELLATION STABILITY

• 1-D CONSTELLATIONS

- GRAVITY GRADIENT DOMINATES DIFFERENTIAL AIR DRAG AT SS ALTITUDE
- AT VERY LOW ALTITUDE (150 KM) DIFFERENTIAL AIR DRAG IS STRONG
BUT ORBITAL LIFETIME IS VERY LIMITED
- 1-D, MULTI-MASS VERTICAL CONSTELLATIONS ARE PREFERABLE FOR GOOD STABILITY

• 2-D CONSTELLATIONS

- EXPLOIT THE GRAVITY GRADIENT FOR OVERALL ATTITUDE STABILITY
(CONSTELLATION'S MINIMUM AXIS OF INERTIA MUST BE VERTICAL)
- RESORT TO DIFFERENTIAL DRAG OR ELECTRODYNAMIC FORCES TO STRETCH
THE CONSTELLATION HORIZONTALLY IN ORDER TO PROVIDE
SHAPE STABILITY

DRAG STABILIZATION LIMITS FOR SINGLE-AXIS HORIZONTAL CONSTELLATIONS

$$\text{AREA/MASS} = A/M_2 = 10 \text{ M}^2/\text{KG}$$

z (km)	Minimum Atmo. Density Exospheric Temp. = 600K		Maximum Atmo. Density Exospheric Temp. = 1100K	
	h_{max} (m)*	$\frac{da}{dt}$ (km/day)**	h_{max} (m)	$\frac{da}{dt}$ (km/day)
150.	2.31×10^5	2.84×10^3	3.23×10^5	3.97×10^3
200.	1.89×10^4	2.29×10^2	4.79×10^4	5.82×10^2
300.	5.47×10^2	7.05	4.51×10^3	5.36×10^1
400.	3.57×10^1	0.42	7.58×10^2	8.80
500.	3.64	0.04	1.61×10^2	1.83

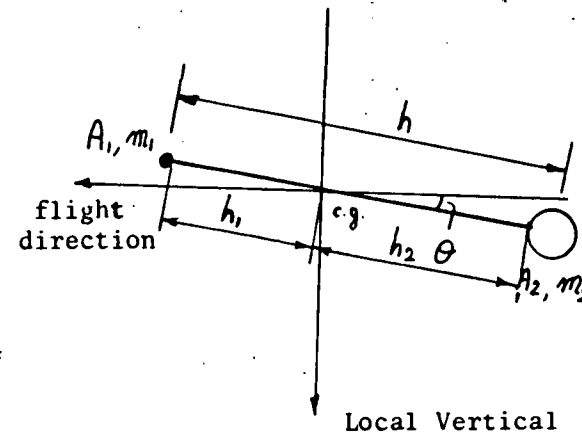

* h_{max} = maximum horizontal length for stable configuration

** $\frac{da}{dt}$ = orbital decay rate

STABILITY LIMITS FOR A "FISH-BONE" CONSTELLATION VS. ORBITAL ALTITUDE

ASSUMPTIONS

$$l_2 = l_1 = 20 \text{ km}$$

$$A_2/m_{12} = 10 \text{ m}^2/\text{kg} ; \quad A_1/m_{11} = 4 \times 10^{-3} \text{ m}^2/\text{kg}$$

$$d_{t2} = 1 \text{ mm (kevlar)} ; \quad d_{t1} = 2 \text{ mm (kevlar)}$$

$$m_{11} = m_{12} = 200 \text{ kg}$$

$$m_{21} = 1000 \text{ kg} ; \quad m_{22} = 800 \text{ kg (deployer)} + 200 \text{ kg (balloon)} = 1000 \text{ kg}$$

301

z (km)	Minimum Atmo. Density Exospheric Temp. = 600K		Maximum Atmo. Density Exospheric Temp. = 1100K	
	h_{\max} (m)*	$\frac{da}{dt}$ (km/day)**	h_{\max} (m)	$\frac{da}{dt}$ (km/day)
150.	9.54×10^4	5.99×10^4	1.33×10^5	8.38×10^4
200.	7.81×10^3	4.83×10^3	1.98×10^4	1.23×10^4
300.	2.26×10^2	1.49×10^2	1.86×10^3 <td 1.13×10^3	
400.	1.47×10^1	8.87	3.13×10^2	1.86×10^2
500.	1.50	0.84	6.65×10^1	3.86×10^1

* h_{\max} = maximum horizontal length for a stable configuration

** $\frac{da}{dt}$ = orbital decay rate

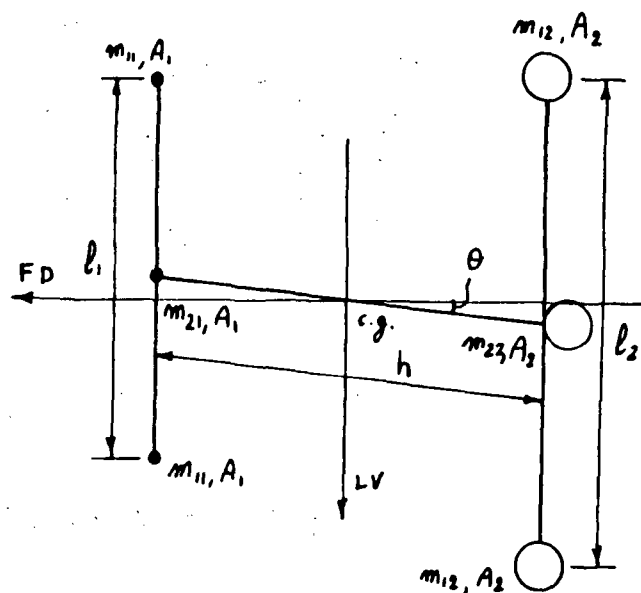

SOME CONCEPTUAL EXAMPLES OF TWO-DIMENSIONAL CONSTELLATIONS HORIZONTALLY
STABILIZED BY AIR DRAG (DSC)

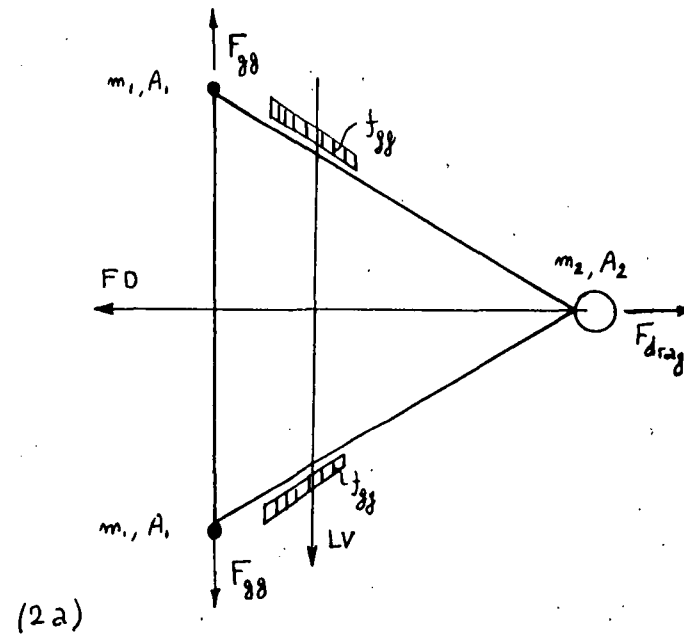
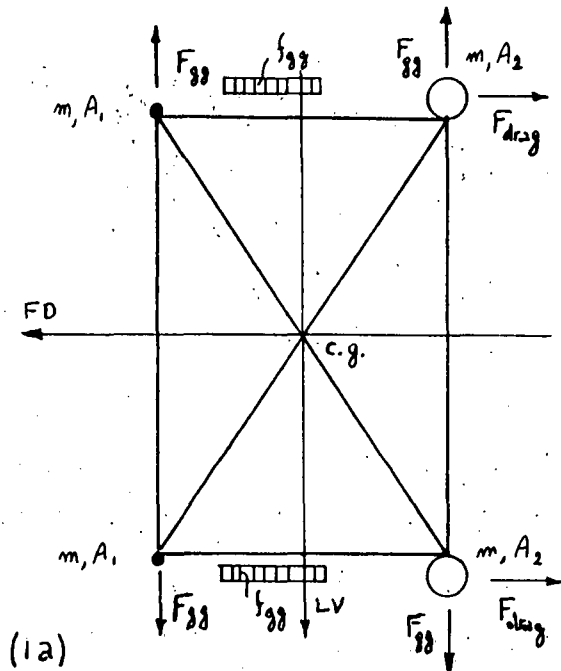

-WITH THIS CONFIGURATION THE DRAG FORCE IS FULLY EXPLOITED TO GUARANTEE
THE MINIMUM TENSION LEVEL IN THE HORIZONTAL TETHERS AND NOT TO COUNTERACT
GRAVITY GRADIENT.

- SOME CONCEPTUAL CONFIGURATIONS OF TWO-DIMENSIONAL CONSTELLATIONS WHERE SHAPE STABILITY IS PROVIDED BY ELECTRODYNAMIC FORCES (ESC)

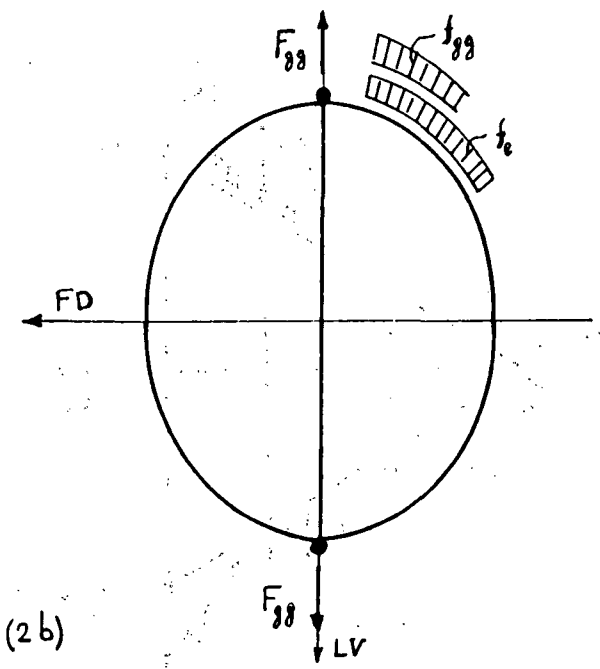
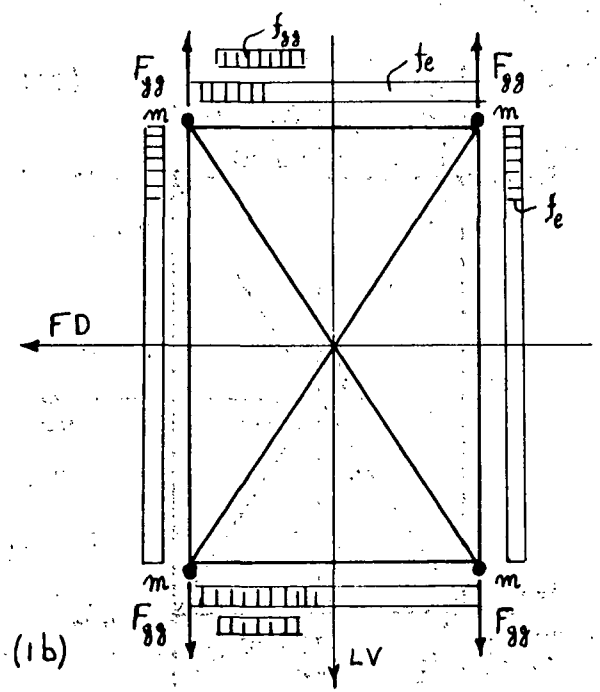

303

-ELECTRODYNAMIC FORCES STRETCH THE CONSTELLATION WHILE THE RESULTANT IS ZERO SO THAT ORBITAL DECAY IS NOT INCREASED

SINGLE-AXIS, VERTICAL CONSTELLATION WITH THREE MASSES

*GOOD STABILITY

*MIDDLE MASS LOCATED AT THE SYSTEM ORBITAL CENTER FOR LOW-G APPLICATIONS

*ORBITAL CENTER IS 1.2 m LOWER THAN THE SYSTEM C.M. IN THE CONSTELLATION UNDER INVESTIGATION

*DESIGN PARAMETERS ADOPTED

-ORBIT ALTITUDE = 500 km

-ORBIT INCLINATION = 28.5°

-TETHER LENGTH = 10 km

- m_1 (S/S) = 90.6 TON

- m_2 (BALLAST) = 9.06 TON

- m_3 (LOW-G) = 4.53 TON

*STATION KEEPING PHASE HAS BEEN SIMULATED

- J_2 GRAVITY TERM TAKEN INTO ACCOUNT

-TETHER TRANSVERSE MODES NEGLECTED

-LONGITUDINAL DAMPERS NOT INCLUDED IN THE SIMULATION

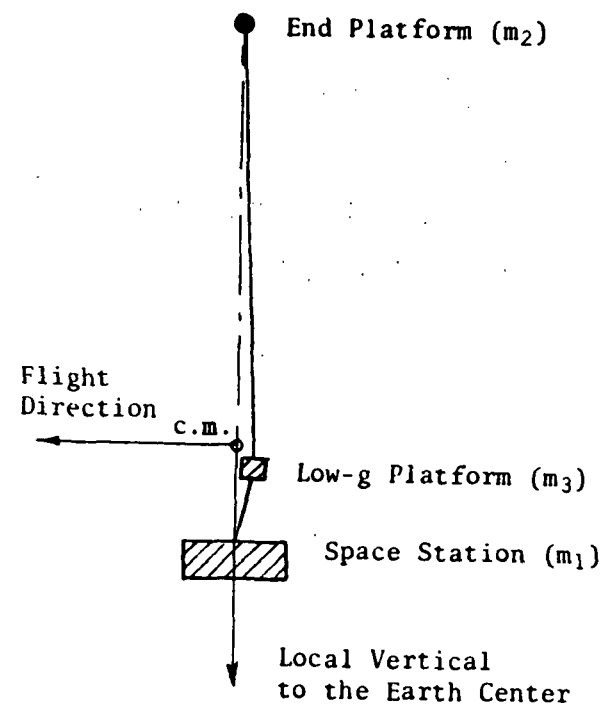

*ACCELERATION LEVEL OF LOW-G PLATFORM PRELIMINARILY ESTIMATED TO BE AROUND 10^{-8} g.

-RADIAL COMPONENT, SHOWN IN THE FIGURE, IS THE DOMINATING COMPONENT

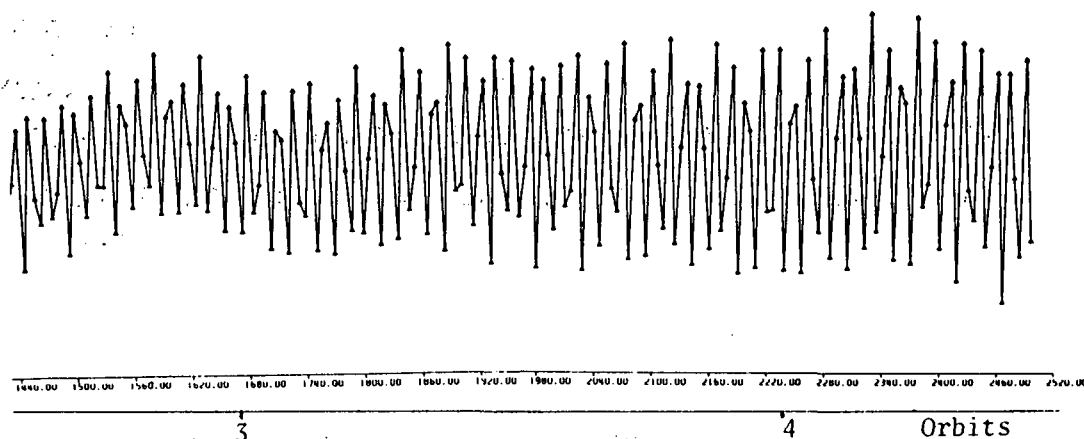
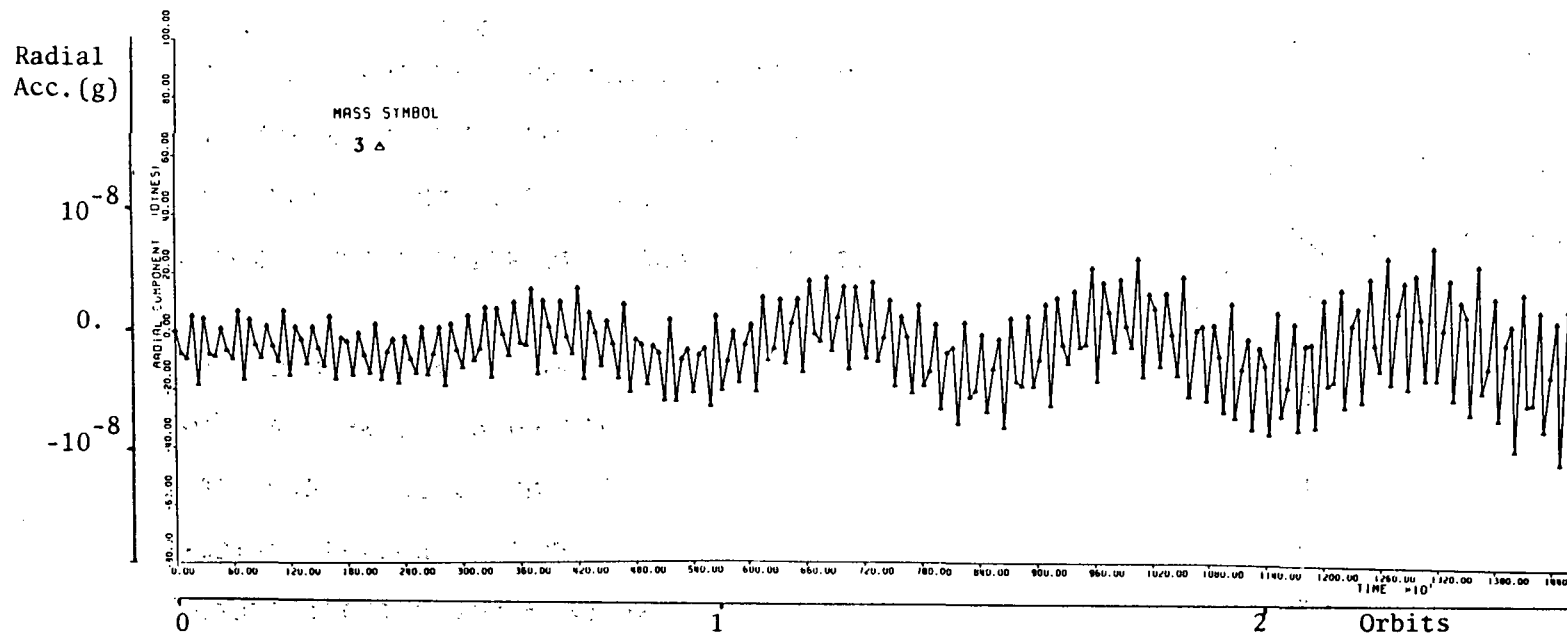

*SINGLE-AXIS, VERTICAL CONSTELLATIONS APPEAR PROMISING FOR LOW-G/VARIABLE-G APPLICATIONS
*HIGH FIDELITY ANALYSIS OF EXTERNAL PERTURBATIONS NECESSARY

305

ORIGINAL PAGE IS
OF POOR QUALITY

DAMPING OF MODAL VIBRATIONS IN 1-D, 3-MASS CONSTELLATIONS

- MICRO-G APPLICATIONS REQUIRE AN EFFECTIVE DAMPING OF MODAL VIBRATIONS
- MULTI-FREQUENCY DAMPING BY MEANS OF ACTIVE TETHER CONTROL APPEARS TO BE THE RIGHT SOLUTION
- GOOD DAMPING OF LIBRATORY, LONGITUDINAL AND TRANSVERSE VIBRATIONS HAS ALREADY BEEN PROVED
- AMPLITUDES AND PHASES OF THE OSCILLATIONS TO BE DAMPED OUT MUST BE PROVIDED TO THE REEL-SYSTEMS

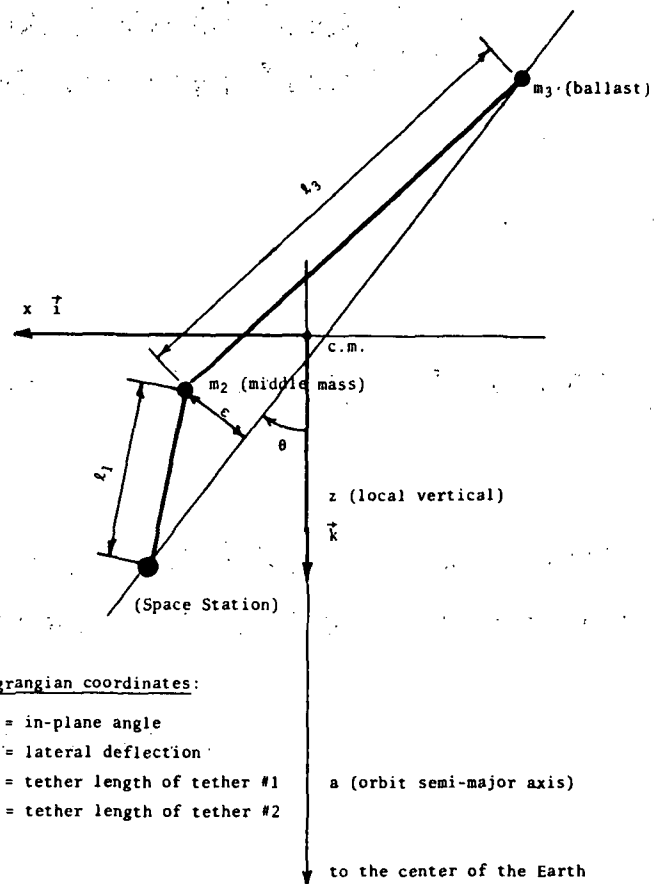

CONCLUSIONS AND RECOMMENDATIONS

- 1-D, HORIZONTAL CONSTELLATIONS STABILIZED BY DIFFERENTIAL AIR DRAG ARE LIMITED BY HIGH ORBITAL DECAY AT LOW ORBITAL ALTITUDES AND SHORT HORIZONTAL LENGTHS AT SS ALTITUDES.
 - 2-D, "FISH-BONE" CONSTELLATIONS' STABILITY IS MORE MARGINAL THAN THAT OF 1-D, HORIZONTAL CONSTELLATIONS
 - 2-D, ALTERNATIVE CONFIGURATIONS PROPOSED
 - QUADRANGULAR STABILIZED BY DIFFERENTIAL AIR DRAG (DSC)
 - QUADRANGULAR STABILIZED BY ELECTRODYNAMIC FORCES (ESC)
 - PSEUDO ELLIPTICAL STABILIZED BY ELECTRODYNAMIC FORCES
 - TRIANGULAR STABILIZED BY DIFFERENTIAL AIR DRAG
 - QUADRANGULAR DSC OR ESC CAN ACHIEVE STABLE DIMENSIONS OF 10 X 20 KM
- POWER REQUIRED FOR ESC AND BALLOON DIAMETER FOR DSC PRACTICABLE
- TRANSIENT DYNAMIC RESPONSE OF THESE COMPLEX STRUCTURES HAS BEEN ONLY PARTIALLY ANALYZED

CONCLUSIONS AND RECOMMENDATIONS - CONTINUED

- 1-D, VERTICAL CONSTELLATIONS ARE PERFECTLY STABLE
 - 3-MASS CONFIGURATION CAN BE CONVENIENTLY USED FOR MICRO-G APPLICATIONS EITHER FROM THE SHUTTLE OR THE SPACE STATION
 - PRELIMINARY EVALUATION OF THE ACHIEVABLE ACCELERATION LEVEL IS AROUND 10^{-8} G. FURTHER STUDIES ARE NECESSARY HOWEVER.
 - MODAL VIBRATION DAMPING BY ACTIVE CONTROL HAS BEEN PROVEN EFFECTIVE
 - 1-D VERTICAL CONSTELLATIONS CAN BE EXTENDED TO MORE THAN 3-MASS IN ORDER TO CREATE A MULTI-PROBE SYSTEM FOR MEASUREMENT OF GEOPHYSICAL GRADIENTS