

GRANT / HQ



University of Colorado at Boulder

254 pages

IN-19586

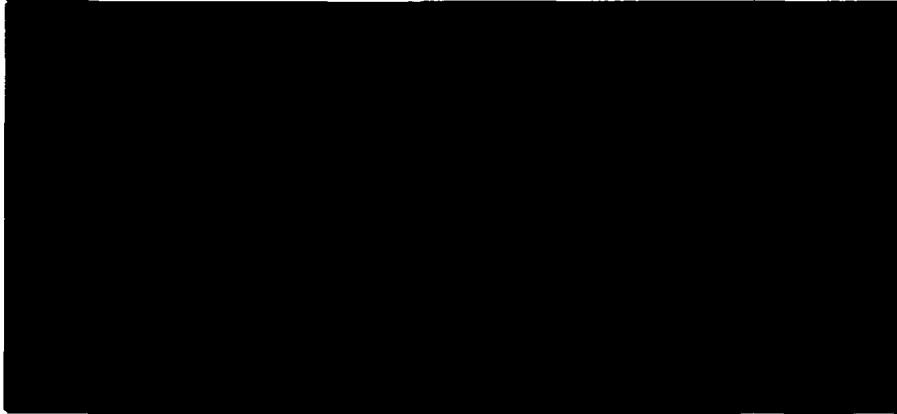

(NASA-CR-176881) A STUDY OF FACTORS RELATED  
TO COMMERCIAL SPACE PLATFORM SERVICES  
(Colorado Univ.) 254 p

N86-30744

CSCL 22A

Unclas

G3/12 3 43277

# Center for Space Law and Policy

---

Boulder, Colorado

**A Study of Factors  
Related to Commercial Space  
Platform Services**

**Prepared for**

**The National Aeronautics and Space Administration**

**(NASA Grant NAGW-884)**

**By**

**The University of Colorado**

**Principal Investigator: S. Neil Hosenball**

**Center for Space Law and Policy**

**Boulder, Colorado**

**August, 1986**

## Table of Contents

Participants.....	2
Preface.....	3
Executive Summary.....	4-12

### SECTION ONE IDENTIFICATION OF FACTORS

Organization of the Report.....	13
I. Introduction.....	13
II. Background.....	15
A. MMS Heritage	15
B. Initial Stages of Fairchild's Leasecraft	16
C. NASA-Fairchild Memorandum of Understanding	17
D. Fairchild's Early Marketing Assessment	17
E. NASA-Fairchild Joint Endeavor Agreement	19
F. Fairchild's Unsolicited Proposal	20
G. NASA Request for Proposal for Commercial Space Platform Services	22

<b>III. Factors Affecting Commercial Development of Space Platform Services.....</b>	<b>25</b>
A. Market Aspects	25
1. Pharmaceuticals	26
2. Crystals	26
3. Glasses and Ceramics	27
4. Metal Alloys and Composites	27
5. Other Market Possibilities	27
6. Summary of Market Aspects	28
B. Insurance and Risk of Loss	29
C. Tax Related Factors	30
D. Space Transportation	31
E. Termination Liability	37
1. Under JEA	38
2. Under Unsolicited Proposal	38
3. Under NASA RFP	39
F. Institutional Barriers	40
1. Source Evaluation Board Process	40
2. Funding Procedures	41
G. Procurement Laws and Regulations	43
<b>IV. Summary - Section One.....</b>	<b>44</b>

**SECTION TWO**  
**RECOMMENDATIONS**

<b>I. Introduction to Recommendations.....</b>	<b>45</b>
A. Market Risk	45
B. Insurance and Risk of Loss	46
C. Tax Treatment	47
D. Space Transportation	48
E. Schedule Uncertainty	49
F. Termination Liability	49
G. Institutional Barriers	50
H. Procurement Laws and Regulations	51
I. Funding Procedures	52
J. Financing	52
<b>II. Conclusion.....</b>	<b>53</b>

Appendix 1  
Chronology of Events

Appendix 2  
NASA-Fairchild MOU

Appendix 3  
NASA-Fairchild JEA

Appendix 4  
Leasecraft Mission Scenario

Appendix 5  
Select Abstracts

Appendix 6  
Explanatory Charts

## **PARTICIPANTS**

### **University of Colorado**

Mr. S. Neil Hosenball  
Director, Principal Investigator  
Center for Space Law and Policy  
University of Colorado, Boulder

Mr. Jefferson S. Hofgard  
Assistant Director  
Research Associate  
Center for Space Law and Policy  
University of Colorado, Boulder

Mr. Donald P. Hearsh  
Director  
Office of Space Science and Technology  
Acting Associate Vice President for Research  
University of Colorado, Boulder

Mr. Ronald Melicher  
Associate Director  
Center for Space Law and Policy  
Professor of Finance, School of Business  
University of Colorado, Boulder

### **Consultants**

Dr. John Naugle  
Consultant  
Washington, D.C.

Mr. L.J. Evans  
President  
Center for Space and Advanced Technology, Inc.  
Arlington, Virginia

## PREFACE

The Center for Space Law and Policy is an interdisciplinary enterprise based at the University of Colorado, Boulder. The Center seeks to promote research and education across a wide variety of disciplines related to space law, business, economics, and policy.

This study, "A Study of Factors Related to Commercial Space Platform Services," was made possible through a grant from the National Aeronautics and Space Administration's Office of Commercial Programs (NAGW-884). The Center would like to express its gratitude and appreciation to personnel at NASA Headquarters; NASA Goddard Space Flight Center; Fairchild Industries; McDonnell Douglas; RCA; Ball Aerospace Systems Division; The Center for Space and Advanced Technology, Inc.; Dr. John Naugle; Johnson & Johnson; and the many others who contributed to the final report.

## EXECUTIVE SUMMARY

In the past four years, the issue of the commercial development of space has come to the forefront of U.S. national space policy. Though the Administration, Congress and NASA have all shown strong support for encouraging the private sector to become more actively involved in the commercial utilization of space, the question remains whether they must do more - at least at these early beginnings - to foster the creation and development of a viable U.S. commercial space industry.

This study was made possible through a grant from the National Aeronautics and Space Administration's Commercial Programs Office (NAGW-884). Section I focuses on the identification of specific factors which hindered the development of commercial space platform services and, in particular, Fairchild's Leasecraft program. Section II of the study contains general and specific policy recommendations addressing common concerns voiced by personnel within industry and NASA.

### SUMMARY OF FACTORS IDENTIFIED IN SECTION ONE

The NASA-Fairchild Memorandum of Understanding (MOU), NASA-Fairchild Joint Endeavor Agreement (JEA), and NASA Request for Proposal (RFP) for commercial space platform services can be seen as three separate yet interrelated attempts to develop a commercially owned and operated space platform system. Some of the factors identified here were apparent in each of the three phases while others were unique to one or two of the phases.

#### A. Market Aspects

The high costs of getting to space and risks associated with activities in space significantly limit the range of products that can be profitably produced in space. The few existing products which have the high cost per unit rate yields and sufficient market demand to warrant consideration as candidates for space processing are certain pharmaceutical products; particularly high grade, defect free crystals; exotic glasses and ceramics; and possibly some metal alloys and composites. Beyond NASA, the market for commercial space platform services is equally as narrow, consisting of a wide variety of "potential users" but, as of yet, no paying users.



From the initiation of the NASA-Fairchild MOU in 1982, through NASA's RFP for competitive procurement in 1985, the only company that had made a substantial investment and developed a comprehensive plan to produce a product in space was McDonnell Douglas. With MDAC's withdrawal from negotiations with Fairchild there was no private sector market for commercial platform services, leaving NASA as the only customer for commercial platform services. With neither Fairchild nor RCA able to obtain a commercial customer, both companies set their price to NASA in response to the RFP at a level exceeding the cost of the Government conducting separate missions. The extremely narrow market for commercial space processing materials had a substantial and negative impact on the prospects for success for both the Leasecraft program as well as the RFP for commercial space platform services.

### **B. Insurance and Risk of Loss**

Following a series of satellite losses, the capacity in the insurance market declined precipitously. When insurance was available, rates reached levels in excess of 20% in 1985. The sharp rise in rates, more stringent restrictions on coverage, and general unavailability of insurance led both RCA and Fairchild in their response to NASA's RFP to request that the Government become the "insurer of last resort". Though the Government generally self-insures under standard procurements for NASA owned platforms, it was unprepared to assume the same risk for a commercial platform. At the time of NASA's request for best and final offers, Fairchild was unable to obtain a commitment from underwriters for insurance. Without insurance, Fairchild concluded that the risks were simply too high to justify continuance of the Leasecraft program under the terms of the RFP.

The absence of an assured source of insurance or risk of loss protection substantially impacted the prospects for a successful development of a commercially owned and operated space platform.

### **C. Tax Related Factors**

No evidence was found that suggested that tax considerations played a major role in the failure to commercialize space platform services. However, it can be argued that Internal Revenue Code provisions in existence at the time served to discourage, rather than encourage, commercial investment in space.

The applicable Treasury regulations adopt a "physical location" test for determining whether a property is used

predominantly inside the U.S. and thus qualified for an investment tax credit (ITC) or accelerated depreciation (ACRS). Under this test, non-communication space-based assets are excluded. The absence of an applicable investment tax credit [ITC] or an accelerated depreciation provision [ACRS] for non-communication, space-based assets results in an unfavorable internal rate of return for non-communication space-based investments when compared to alternative ground-based investment opportunities. This, in turn, has an adverse impact on the market for space platform services since higher investment costs result in higher platform service fees.

The tax laws also do not allow the establishment of tax deductible reserves for casualty losses for a commercial business, thus requiring the purchase of insurance to cover damage to, or loss of, the asset, facility, or product.

In sum, tax factors did not play a major role however, under similar circumstances in the future and unless changed, they will continue to discourage extensive commercial investment in space.

#### **D. Space Transportation**

A predominate factor influencing the failure to develop commercial platform services was, and still is, the high cost of transportation to and from space and the high cost of providing utilities in space.

Initial free shuttle flights as provided in the RFP did serve to lessen the financial risks to the contractor. However, for the space platform services contractor as well as potential commercial customers, platform services fees and product prices had to be calculated according to estimated transportation costs over five to ten years, after the free flights were used.

To date, transportation to and from space costs approximately 20,000 times the cost of ground transportation. In a similar vein, the provision of utilities in space costs approximately 16,000 times. Both of these figures serve to narrow the market for platform services to products with extremely high per unit yields with an estimated market demand in excess of \$100 million. Unless the cost of space transportation drops dramatically over the next decade, the prospects for extensive and profitable commercial investment in materials processing in space or space facilities supporting such an industry are discouraging.

## E. Termination Liability

Termination liability can best be described as the obligation of the buyer of the product or services to pay damages to the seller if, for any reason, the buyer terminates performance under the contract for the purchase of such goods or services. Termination liability was present in each of the three phases.

It is evident that termination did not create a barrier in the negotiation of the NASA-Fairchild JEA. Fairchild assumed the entire risk that it might not obtain the free shuttle launches agreed to by NASA

Under the terms of Fairchild's unsolicited proposal termination presented two problems. First, the proposal included a clause enabling Fairchild to "trigger" NASA's otherwise unilateral termination for convenience clause, in the event that Fairchild lost its first non-NASA customer and could not find another customer. Second, it was NASA's view that the proposal did not permit them to exercise a default termination, but instead granted NASA limited rights for "outage" penalties (i.e., a reduction in the price to be paid as a result of failure to provide contract services). Both of these conditions, in addition to the procurement problems associated with an unsolicited proposal, led NASA to decline consideration of the unsolicited proposal.

NASA's RFP for the competitive procurement for space platform services contained the standard Government termination for convenience clause. In addition to a quarterly schedule outlining the cumulative maximum liability the Government would incur in the event of a termination for convenience, the RFP stated that nothing in the RFP or contract should be construed as making the Government liable for any amount exceeding actual appropriations in relevant program areas or for the lack of appropriations sufficient to fund such liability.

NASA expected the contractors to assume the risk of obtaining additional customers other than NASA - whether Government or commercial - and based upon this assumption of risk, NASA would receive appropriate credit (or equity) in the termination schedule.

Neither Fairchild nor RCA proposed any equity value in their termination schedule and, from NASA's point of view, both proposers sought termination liability limits exceeding what the Government was prepared to offer.

Though the termination issue did present a formidable obstacle to the success of the RFP, there appears to have been a willingness on the part of at least one of the

proposers to negotiate a mutually acceptable resolution to the termination problem by assuming a significant portion of termination liability.

#### **F. Institutional Barriers**

No evidence was found that the composition of the Source Evaluation Board (SEB), its location at Goddard, or Goddard's previous experience with the Tracking and Data Relay Satellite System (TDRSS), influenced the objectivity of the Board or resulted in a selection process prejudicial to the development of commercial space platform services.

The Office of Commercial Programs played little or no role throughout the three phases to develop a commercially owned and operated space platform. This is largely due to the fact that the Office had only recently been established. However, in the future, it must play a major role in similar endeavors if it is to succeed in its stated mission.

Uncertainty in Government funding (i.e., termination "mid-stream" in a project), availability of funding for termination liability, and the restraint imposed by current Congressional and NASA procedures for authorization and appropriations on a fiscal year basis will continue to hinder substantial commercial investment in space.

Also working against the development of a commercially owned and operated platform was NASA's unwillingness to view the long run value that developing a commercial space platform would have on encouraging and fostering future commercialization initiatives by the private sector. In addition, the contractors unwillingness to assume the risk of obtaining non-NASA customers to offset the cost to NASA for the platform services had a negative impact on the prospects for a successful commercial space platform.

#### **G. Procurement Laws and Regulations**

A final barrier rests with existing procurement laws, regulations and procedures. In contrast to the flexibility afforded NASA under Section 203 (c) (5) of the National Aeronautics and Space Act, procurement laws, regulations and procedures require - with very limited exceptions - full and open competition. P.L. 83-36, 98-525 and 98-577 recently enacted by Congress have made it more difficult for NASA to accept unsolicited proposals or to make sole source awards.

Using the procurement process is time consuming as well as inflexible. The procurement laws have been interpreted and applied so as to require NASA and other Government

agencies to set forth technical requirements in great detail. Once proposals have been submitted there is little room for innovative ideas or approaches which deviate from the the RFP requirements but may be more beneficial to the Government.

The requirement for competitive selection where there is a known Government requirement discourages companies from identifying space facilities that could be developed by the private sector. It makes no financial sense for a company to expend its funds to design a facility only to have the Government then decide to proceed with a competitive procurement. It is unrealistic, to expect the private sector to fully initiate a program of research leading to final design and development with the prospect of competitive selection enforced in the final stages.

## **SUMMARY OF RECOMMENDATIONS CONTAINED IN SECTION TWO**

The Administration, the Congress and NASA all publicly support the concept of space commercialization. If space commercialization is to succeed, there must be tangible evidence that all three entities will support the concept with clear objectives and commitments. On the industry side, the private sector must be willing to make the capital investment and to assume or share with the Government some of the risks associated with the development of a new industry and new markets.

The recommendations contained in this section and those that follow are directed to the Administration, Congress, and to NASA.

### **A. The Market Risk**

O There may be occasions when NASA should be willing to share the market risk with the supplier of goods and services to promote the early development of a commercially financed and operated space facility that would be used by other government agencies or by the private sector. For this to happen however, it may be necessary for the Administration, Congress and NASA to approve funds for this purpose over and above the the basic NASA budget request. Any such "equity" or "commercial value" would be recouped by NASA from non-NASA sales by the commercial developer to other private sector entities or other Government agencies as was proposed in the space platform services procurement.

## **B. Insurance and Risk of Loss**

O Because of the high capital investment required for the commercial development of a space facility, the risk of loss during launch or on orbit is substantial and, unless resolved in some fashion by the space insurance industry, the Administration, Congress or NASA, it will continue to be a major barrier to the development of commercial activities in space. One alternative is to allow commercial entities to establish tax deductible reserves to cover casualty losses or damage to space assets.

O The possibility of sharing the risk of loss in the space platform services procurement was never explored. In the future, and as part of these recommendations, in some instances NASA should share risk of loss with the commercial developer. This option should be explored more thoroughly.

## **C. Tax Treatment**

O Private sector initiative directed at the commercial development of space should receive equal, if not preferential, treatment under the tax laws and regulations.

## **D. Space Transportation**

O Congress and NASA should explore the question of reduced transportation costs with the materials processing industry, focusing on what effect, if any, a reduction of transportation costs would have on expanding the market. Another approach would be to expand the use of Space Services Development agreements with materials processing concerns as well as others who offer to develop commercial facilities. This approach, rather than being a direct form of subsidy, would require repayment, whole or in part, of the launch services furnished by NASA; in effect creating a partnership between those industries and the Government.

## **E. Schedule Uncertainty**

O The solution may again be a sharing of the risk of delay in commercial space initiatives.

## **F. Termination Liability**

O The recommendations outlined in the areas of sharing the market risk and the risk of loss, are equally applicable to sharing termination liability.

## **G. Institutional Aspects**

O NASA as an organization must fully support commercialization the effort. That includes the Administrator, the Associate Administrators and the Center Directors. When a potential commercial development is identified by NASA or proposed by industry, it is important that the Administrator, Program Directors, Associate Administrators and Center Directors review their programs to identify potential Government participation through the purchase of services or product by those organizations.

## **H. Procurement Laws and Regulations**

O When a Joint Endeavor Agreement or an unsolicited proposal proposes a product or service that could be used by both Government and non-Government users, and after identifying the Government uses in accordance with the previous recommendation, NASA should negotiate a contract with such offeror for the procurement of the Government services assuming agreement on price can be reached.

O Where NASA has identified a facility, product or service that can be used by NASA and other non-Government customers, NASA should seek expressions of interest from the private sector for the commercial development of such a facility, product or service. Rather than employing the standard NASA procurement procedures, NASA should develop procedures permitting greater flexibility in stating its requirements, negotiating final agreements, and reducing the lead time for a contract award. NASA developed the Announcement of Opportunity procedures to meet its unique needs for experiment selection. Commercialization of space is sufficiently unique so as not to lend itself to the normal NASA procurement process. Pending the establishment of such procedures and pending clarification of NASA's authority under the Space Act, NASA should review its selection criteria and SEB scoring system recognizing the importance of space commercialization.

O Where other major non-Government customers have been identified who would use the service or buy the product, NASA - with the permission of the supplier - should contact such non-governmental customers to negotiate as a team with the supplier in those situations where it is highly unlikely that the commercialization effort could proceed without the Government and the non-Government purchase of the goods or services. This provides the opportunity for the three parties to allocate and share the substantial risk involved in space commercialization.

O The General Counsel's office should review the authority of NASA to carry out the above recommendations under the authority of the Space Act, Section 203 (C) (5), taking into account the decision interpreting that section in the case of AFGE vs. Paine. In the event the General Counsel determines that NASA lacks the authority, then it is recommended that Congress enact legislation to grant NASA the authority to implement this recommendation.

### **I. Funding Procedures**

O Congress, in concert with the Administration and NASA, should review the funding procedures normally used for NASA projects to see whether, as a matter of policy, those procedures should be changed to encourage and support space commercialization activity. Specifically, all three entities should consider granting NASA authority relieving them of the requirement to obligate funds for the contingent liability of a convenience termination. Also, NASA projects associated with a commercialization effort should be fully funded through appropriations and authorization rather than on a fiscal year basis.

### **J. Financing**

O The Congress may wish to reconsider HR7412 introduced to the 96th Congress Second Session, to establish a Space Industrial Corporation to promote, encourage, and assist in the development of new products, processes, services, and industries using the properties of the space environment and in the use of space technology. H.R. 7412 was introduced on May 21, 1980.

## **CONCLUSION**

In view of the recognized importance of space commercialization, the U.S. Government should at least be willing to share and reduce the risks involved in commercial space activities at this stage in its development.



**SECTION I**

**IDENTIFICATION OF FACTORS**

## ORGANIZATION OF THE REPORT

This report is divided into two sections. Section I focuses on the identification of specific factors which affected the full development of commercial space platform services and, in particular, Fairchild's Leasecraft program. A substantial portion of Section I of the study is directed towards a description and analysis of three phases to commercialize space platform services: the NASA-Fairchild Memorandum of Understanding (MOU) and Joint Endeavor Agreement (JEA); Fairchild's unsolicited proposal to NASA; and, NASA's Request for Proposal (RFP) for Commercial Space Platform Services. Each of these phases represents a separate attempt to move the concept of a commercially owned and operated space platform off the drawing boards and into space. Without an understanding of the underlying requirements, constraints, and conditions inherent in each phase, the factors subsequently identified as impediments or barriers cannot be adequately understood. Some of the barriers identified are present in each phase, while others are present in only one or two.

Section II of the study focuses on general and specific policy recommendations, addressing issues of mutual interest to NASA and industry. Appendices to the study include a chronology of events; the NASA-Fairchild Memorandum of Understanding and Joint Endeavor Agreement; explanatory charts; and a series of select abstracts related to the commercial development of space.

### I. INTRODUCTION

In the past four years, the issue of commercial uses of space has come to the forefront of U.S. national space policy. The Administration, Congress and NASA have all shown strong support for encouraging the private sector to become more actively involved in the commercial utilization of space.

The President's National Space Policy issued on July 4, 1982, stated "the United States Government will provide a climate conducive to expanded private sector investment and involvement in space and space-related activities."

In December, 1983, an industry commercial space group formed to advise the White House on how provide such a climate stated in its report that "commercial activities in space by private enterprise need to begin now if our nation is to retain leadership in science and technology and advantages in international trade."

In his January, 1984, State of the Union Address the President stated: "We will soon implement a number of executive initiatives to promote private sector investment in space."

Finally, in 1984, the House and the Senate decided to amend the National Aeronautics and Space Act of 1958 as follows: "The Congress declares that the general welfare of the United States requires that the National Aeronautics and Space Administration seek and encourage, to the maximum extent possible, the fullest commercial use of space."

Still later in 1984, NASA issued its own Commercial Space Policy declaring that "NASA is encouraging free enterprise to participate in space by inviting industries and other private entities to finance and conduct business in space."

NASA has made a significant and substantial effort to implement the Administration's policy and Congressional mandate through the implementation of the NASA Commercial Space Policy. In late 1984, NASA established the Office of Commercial Programs to serve as an advocate and focal point for the commercial development of space. In addition, several Centers for Commercial Space Development, which utilize the expertise of industry, academia and NASA, have been funded. In 1985 NASA selected five such centers and, depending on the availability of funding, has plans for additional centers.

NASA has also developed and offered various types of industry-NASA agreements intended to assist and encourage the commercial exploitation of space. Through Joint Endeavor Agreements, NASA has offered the private sector free shuttle flights, representing an expenditure by NASA of millions of dollars. The same is true for the Space Services Development Agreement where, in effect, NASA delays the repayment of flight costs until a revenue stream results from the operation of the developed space facility. In addition, NASA also supports basic university and industry research that could lead to the development of new products in space.

Despite NASA's current efforts, and the high level of policy support for private commercial initiatives in space, little has been accomplished towards meeting overall U.S. commercial objectives in space. The high risks and costs associated with space activities have proven to be difficult obstacles for the private sector to overcome. In telecommunications satellites, the private sector has found a profitable means by which to exploit the commercial potential of space. Private sector initiatives in launch vehicles,

materials processing in space, and space-based facilities have not yet experienced the same degree of opportunity and prosperity. This has led some observers to become overly critical of the "hype" associated with commercial opportunities in space and, in turn, critical of the Government's implementation of commercial objectives in space.

The question still remains whether the Administration, Congress, and NASA must do more to foster at these early beginnings the creation and development of a viable commercial space industry.

The subject of this report, the development of commercial space platform services - and in particular the Leasecraft free-flying platform - touches nearly all aspects of the commercialization issue. Though the Leasecraft free-flyer and the NASA procurement for commercial space platform services both failed to materialize, the lessons that can be learned should prove valuable.

## **II. BACKGROUND OF COMMERCIAL SPACE PLATFORM SERVICES PROGRAM**

The principal players in the attempt to develop commercial platform services, and in particular the Leasecraft program, were Fairchild Industries, McDonnell Douglas Astronautics Company (MDAC), NASA Goddard Space Flight Center, NASA Headquarters, Johnson & Johnson, and RCA. Each entity, over the several years of study and research into the organization and feasibility of the concept played a role in the course of events that ultimately led to the termination of the NASA RFP in 1985. A condensed chronology of key events appears in Appendix 1.

Because of their significance as separate yet interrelated attempts to commercialize the platform services, the NASA-Fairchild MOU and JEA, Fairchild's unsolicited proposal, and NASA's RFP are examined in detail. The NASA-Fairchild MOU and JEA can be found in Appendix 2 and 3 of this report.

### **A. The MMS Heritage**

In 1981, the Goddard Space Flight Center conducted a study to assess the feasibility and capability of developing a Multi-mission Modular Spacecraft to support McDonnell

Douglas' (MDAC) free-flyer Electrophoresis Operations in Space (EOS). McDonnell Douglas had begun their EOS experimentation, employing a continuous-flow process, around 1977. The results of the Goddard study, and a separate study conducted by Fairchild on the potential market for MMS operations, concluded that Goddard's initial MMS design could not supply sufficient power for EOS and that a modified version of the MMS, which more efficiently used the shuttle's capability, could compete more effectively for NASA and DOD business in the shuttle era. More specifically, the MMS system could only supply 1 kilowatt of power, while McDonnell Douglas' (MDAC) initial EOS design required at least 3.5 kilowatts of power.

## **B. Initial Stages of Fairchild's Leasecraft System**

In the fall of 1982, Fairchild decided to pursue the idea of a modified MMS, seeing a potential market for a small, commercially owned and operated space platform that could service commercial and Government payloads. The concept was relatively simple. The shuttle would deploy the first Leasecraft system in orbit, complete with experiments housed in detachable modules. For a revisit, the shuttle would load new payload modules into the bay and return to orbit, rendezvousing with the Leasecraft system. During rendezvous, the remote manipulator arm would latch on to the Leasecraft system, and bring it back to the bay to exchange the new payload modules for the old payload modules. The shuttle would then redeploy the Leasecraft system - complete with new modules - and bring the old modules back to earth for product delivery or for observation, analysis, and testing. A typical mission scenario appears in Appendix 4 of this report.

Technically, the Leasecraft system would be capable of carrying two or more payloads at once, or carry different payloads in sequence through on-orbit payload exchanges using the shuttle. The platform was also designed to supply up to 7.5 kw of power, thereby satisfying MDAC's requirements as well as other potential users. Essential to the Leasecraft concept however, was the objective that the program be an entire operating system which included an extensive ground based component as well as the platform in orbit. The Leasecraft platform was to have its own operational control center, logistics system of spare modules and ground support equipment, servicing equipment, and staff for operations and marketing.

### **C. NASA - Fairchild Memorandum of Understanding**

Fairchild Industries recognized early on that Leasecraft would require NASA's "whole-hearted" support and, in August 1982, sought and obtained a Memorandum of Understanding (MOU) with NASA. The MOU states: "NASA is, therefore, interested in a commercial firm opting to design, develop, and provide such a platform to users through lease or purchase." In addition, the MOU notes "NASA and Fairchild Industries, having a mutual interest in the development and commercial availability of a small space platform, and associated services, based upon MMS technology, agree to explore the feasibility of an agreement on a joint endeavor to bring such a platform into being, demonstrate its capability in 1986 and have it commercially available for Governmental and commercial users for at least 10 years beginning in 1986."

Under the terms of the MOU, the endeavor was to proceed in three phases. First, a feasibility and preliminary design phase in FY 1982. Second, a developmental phase extending from CY 1983 through CY 1986, with a six-month in-orbit demonstration in CY 1986. And third, an operational phase from CY 1987 through CY 1996. No exchange of funds between NASA and Fairchild Industries would be expected in phases 1 or 2.

### **D. Fairchild's Early Market Assessment**

By February 1983, Fairchild had established the Fairchild Space Operations Company to oversee the Leasecraft program. During the previous year, Fairchild held extensive discussions with a host of potential users. From these discussions, Fairchild concluded that the Leasecraft market consisted of two segments - materials processing, and data collection and transmission.

These two markets indicated that two technical versions of Leasecraft would be needed. The materials processing configuration would be a high power system with coarse pointing and stabilization, while the data collection version would be a low power system, with fine pointing and low jitter capable of high data rates. Both systems were to be operationally ready for an "early 1987 launch". In addition, Fairchild narrowed the list of potential users to three "major customers"; NASA, DOD, and McDonnell Douglas. MDAC in collaboration with Johnson & Johnson had made a substantial investment in their EOS facility and had developed a comprehensive plan for the manufacture and marketing of space-processed pharmaceuticals.

According to Fairchild's assessment, NASA was "interested" and believed the Leasecraft concept to be sound. From Fairchild's point of view, NASA wanted to help Fairchild "succeed through lowering technical and financial risks, but not by providing Fairchild with an overt monopoly position for Government business". Further, Fairchild believed that NASA "might be willing to make Leasecraft a standard shuttle service", though the "cost per hour of observation in the shuttle/sortie is of grave concern". Lastly, Fairchild's assessment of NASA's status in early 1983 noted that "current spacecraft procurement requires very early NASA funding."

Fairchild's 1983 assessment of DOD as a major user describes DOD as "very interested" and "if the Leasecraft technical concept is satisfactory, DOD will fund further efforts."

The assessment of McDonnell Douglas' status as a major user noted that MDAC "wants to be operational by 1987 but wants to keep their options open for either their own spacecraft, an RFP to industry, sole source with Fairchild, or using shuttle sorties." Fairchild and MDAC had already signed an MOU and had agreed to conduct a joint study on EOS and Leasecraft.

As of February 1983, Fairchild set an overall marketing strategy to effectively deal with each of its intended major customers. On the NASA side, Fairchild set the objective of obtaining a Joint Endeavor Agreement with NASA to establish Leasecraft's credibility and obtain a bankable agreement in 1983 for a four year lease of one Leasecraft beginning in late 1987 with NASA to provide technical services and two free launches to lower Fairchild's technical and financial risk.

Fairchild's strategy with MDAC was to conduct a joint study with MDAC to develop their confidence in the Leasecraft and ensure compatibility of EOS with Leasecraft. Within that context, Fairchild was willing to offer MDAC an exclusive role for the provision of Leasecraft power and propulsion modules, and a free EOS launch, with six months service and a revisit. In return, Fairchild hoped to gain an agreement in 1983 from MDAC to use the Leasecraft system in commercial operations.

Within DOD, Fairchild had targeted DARPA as a customer base and was prepared to offer one Leasecraft and standard services for four years, starting in the fourth quarter of 1987, payable at a rate of \$4 million per month (1983 dollars) per month of service. This offer was to be on the condition that DARPA agree to sign a "bankable" agreement and provide \$100 thousand earnest money on or before October 1,

1983, and to provide launch services for the initial Leasecraft launch and one revisit for refurbishment during a four year lease and for DOD payload changeouts.

#### **E. NASA - Fairchild Joint Endeavor Agreement**

In August 1983, Fairchild obtained a Joint Endeavor Agreement with NASA. Under the terms of the agreement, Fairchild would develop the Leasecraft platform as a commercial venture, with no transfer of funds between NASA and Fairchild. NASA would supply an initial test flight and a revisit together with associated launch services.

Although the JEA provided that no funds would change hands, it was recognized that NASA might wish to use the Fairchild platform for one or more of its programs. Accordingly, NASA and Fairchild also signed a separate "Letter of Agreement" attached to the JEA, pledging both parties to "jointly and expeditiously" examine the technical compatibility and economic suitability of the Fairchild platform for the performance of one or more NASA missions.

Phase 1 of the JEA called for feasibility studies and preliminary design work, including the preliminary design of Leasecraft, market surveys of potential users and economic analysis, and preliminary schedules for the program. Phase 2 called for program development and flight testing, including research, design, development, and manufacture of the test vehicle and associated ground hardware and software; and planning with NASA and other users for the operational period.

In accordance with the JEA, Fairchild initiated a market survey to further identify and document potential commercial and government users. Their survey included over 200 briefings with potential Government and commercial users; identification of candidate technologies for manufacturing in space; and estimates of the market for new pharmaceutical products and for one crystal product (gallium arsenide).

The results of Fairchild's marketing survey revealed little that Fairchild had not already anticipated. Pharmaceutical products were judged to be the most promising product market, with EOS being the most promising process by which to produce commercially marketable pharmaceuticals in space. McDonnell Douglas, then in collaboration with Johnson & Johnson, was the only entity engaged in EOS activity, attempting to produce a large glycoprotein molecule - erythropoietin - which stimulates the production of red blood cells. MDAC had estimated a domestic annual sales figure in excess of \$100 million dollars for erythropoietin.



Alongside the potential market for pharmaceuticals, Fairchild identified the preparation of ultra-pure, defect-free crystals as another promising space processing activity. Gallium arsenide (GaAs), cadmium telluride (CdTe), indium phosphide (InP) and mercuric iodide (HgI<sub>2</sub>) were cited as particular candidates for space processing. Sales projections for these crystals were set at \$10-20 million, marginal to be a Leasecraft customer. According to Fairchild's marketing survey, no organization had demonstrated a process, a product or a market that could justify the commercial production of crystals in space. Fairchild did, however, see the potential for military production of these crystals where profit considerations would not weigh as heavily as in industry.

Also, in accordance with the separate Letter of Agreement, Fairchild submitted in 1984 a Mission Suitability Report to document the technical compatibility of Leasecraft with a number of NASA missions, including the EUVE, XTE, STARLAB, SIRTF and LANDSAT missions.

#### **F. Fairchild's Unsolicited Proposal**

In early 1984, Fairchild set about the task of reaching a firm agreement with their two most promising customers - NASA and McDonnell Douglas. In April 1984, Fairchild submitted an unsolicited proposal to NASA to provide three years of service for the Extreme Ultraviolet Explorer, the X-ray Timing Explorer, and a materials processing experiment. Fairchild also submitted a firm fixed price proposal to MDAC to provide five years of service to support MDAC's EOS program.

Fairchild's decision to submit an unsolicited proposal to NASA in 1984 can be viewed from two perspectives. From Fairchild's point of view, the unsolicited proposal was intended to document, for NASA's benefit, the economic suitability of the Leasecraft system. The contract provisions in the unsolicited proposal were intended to serve as model provisions for the purpose of discussion.

From NASA's point of view, the unsolicited proposal raised the more complex procurement issue of competition versus sole-source procurement. In July 1984, NASA received a request from the House Science and Technology Committee pertaining to the "Selection of Support Platforms for Payloads". The Committee (House Report 98-629) noted that "it is necessary to establish guidelines for determining when it makes sense to put payloads on either a free-flyer, unmanned platform, the Space Station, or Spacelab." The Committee directed NASA "to develop selection criteria for

each available support platform" and submit the guidelines to the Committee by January 1, 1985.

Already in receipt of Fairchild's proposal, the request from the Committee placed NASA in an awkward position. As one NASA source stated at the time:

It seems to me we are obligated to assess how the Leasecraft proposal meshes or fails to mesh with this obligation to the Hill. We should be careful not to prejudge the study results prematurely, in other words, should the Leasecraft proposal drive the study results or should it be the other way around?

Even without selection criteria established at the time Fairchild submitted the proposal, NASA was keenly aware that any acceptance of the proposal "raised the over-arching procurement consideration of competition versus sole source". The relevant statute governing procurement, Title 10 U.S. Code Sec. 2304 (g) provides that:

In all negotiated procurements in excess of \$25,000 in which rates or prices are not fixed by law or regulation and in which time of delivery will permit, proposals, including price, shall be solicited from the maximum number of qualified sources consistent with the nature and requirements of the suppliers or services procured...

Any exception to this legal requirement would have to be explained and justified by NASA, thus raising two questions. First, can or should NASA accept an unsolicited proposal? Second, if NASA did accept Fairchild's proposal, could a defensible justification for non-competitive procurement (JNCP) be argued?

In the case of the former, NASA believed it could not accept Fairchild's proposal where there was a known government requirement (i.e., the EUVE and XTE missions). The second option, a defensible JNCP for Fairchild, was not judged to be in NASA's interest. As one NASA official put it:

The extent of other private sector interests in competing for Explorer requirements is unknown; however, the thrust of all congressional policy and current legislation is unmistakably in the direction of the reliance upon private sector competition to determine the lowest cost to the Government.

The questionable success of a JNCP, combined with the recent request for clear-cut guidelines for the selection of platforms from the House Science and Technology Committee, led NASA to determine that Fairchild's unsolicited proposal was inappropriate for consideration.

Having reviewed Fairchild's unsolicited proposal and Mission Suitability Report, NASA decided that it was interested in procuring the services of a commercially owned and operated platform. In September 1984, NASA decided to procure such services by competition, declined Fairchild's proposal, and issued an RFP for Space Platform Services.

Fairchild's firm fixed price proposal to MDAC did not fare much better than their experience with NASA. Negotiations over the proposal were suspended in December 1984 and reinstated for a short period in 1985.

#### **G. NASA RFP for Commercial Space Platform Services**

On January 23, 1985, NASA held a preproposal conference which was attended by 15 organizations interested in the basic firm fixed price contract for mission services. The award date was planned for September 1985. From the award date to September 30, 1988 the selected contractor would complete the platform development. Starting on October 1, 1988, through September 30, 1995, the contractor would perform 60 months of on orbit platform services. The contractor would receive payment upon delivery of acceptable service which would be sometime after October 1, 1988, thus requiring private sector financing for platform development prior to receiving any NASA funds.

The statement of work for 60 months of on orbit platform services included:

- O Performing all tasks necessary to analytically integrate the payload module into the platform/space transportation/tracking data systems;
- O Arranging for launch services;
- O Arranging for tracking and data acquisition services;
- O Providing physical integration of payload module with the platform (on the ground or on orbit);
- O Conducting operations by a contractor's platform operations control center;

- O Retrieving data and returning to users;
- O Returning the payload to the ground following completion of the mission.

Candidate missions specified in the RFP were the Extreme Ultraviolet Explorer (EUVE), the X-Ray Timing Explorer (XTE), and the Microgravity Science capability mission. In addition, the RFP requested 17 months of unallocated time for either a mission extension and/or a fourth mission. The payload modules were not part of the procurement, and the platform services contractor would provide mission unique services under a separate contract.

The RFP was unique in several aspects from the usual NASA Request for Proposal. First, it required the contractor to privately finance, own, and operate the system, and demonstrate the capability to manufacture and place the platform in service without resorting to government financing. The normal NASA procurement contract provides for progress payments during the manufacture of the payload or product being procured by NASA. NASA's previous procurements were almost always either fixed price contracts with progress payments, or a cost reimbursement form of contract - either fixed price incentive, cost plus incentive, or cost plus award fee - where the contractor receives reimbursement for cost incurred during development and for costs incurred after the start of services.

A second difference between the Platform Services RFP and normal NASA procurement practice was that the RFP specified the contractor would be fully responsible for system reliability and for performance of the platform. There would be no government technical monitoring and, if there was a failure of performance, no payments would be made. In assuming this responsibility, the contractor would perform the contract in a commercial manner and not be subject to the complex reporting and data requirements that are normally imposed under a government contract. Following this commercial approach, the production cost of the platform should have been lower since additional cost burdens associated with the normal procurement process would have been avoided.

The contract also contained a standard termination for convenience clause in the event the Government would terminate the contract for any reason whatsoever. Again, unlike a normal NASA procurement contract, the contract contained a termination liability schedule keyed to funds available out of the Explorer program.

The RFP stated the procurement was intended to encourage contractors to propose pricing policies that would motivate NASA and the contractor toward mutually beneficial operations such as co-occupancy with other payloads (NASA or commercial), and extended service at lower rates.

The RFP resulted in the submission of two proposals, one from Fairchild heading a team of subcontractors; and one from the RCA Corporation which also included a team of subcontractors. In accordance with NASA procurement procedures, a Source Evaluation Board (SEB) was established to review the proposals in accordance with predetermined criteria. The Selection Official was to be the Associate Administrator for the Office of Space Science and Applications.

The SEB established evaluation criteria, ground rules for a recommended service fee, and other factors that should influence the procurement. The ground rules for recommended service fee, which were not reviewed by Senior Management at NASA Headquarters, were:

- O The service fee must be lower than the cost of the traditional expendable approach;
- O The service fee must be comparable with the cost of a newly developed Government platform with appropriate consideration for additional platform capability, commercial rebate potential, and guaranteed service offers and proposals.
- O In comparing the traditional expendable approach with the platform services approach, the comparisons should not, at this time, include consideration for the value of fostering commercialization of space.
- O Funding for the service fee should come from the Code E (Space Science and Applications) and T (Tracking and Data) program offices to support activities traditionally funded at the Program Office level rather than funded from Center funds;
- O Funding from the Code E and T program offices should not exceed what they otherwise would have paid under the development of a new government platform;
- O The lowest cost alternative of using a refurbished Solar Maximum Mission (SMM) should only be used as a basis for comparison with a service fee if NASA is willing to let the platform services contractor have access to the same capital assets used by the Government.

Other factors that were to be applied in evaluating the service fee, but not given a designated dollar value, were:

- O Flexibility to obtain extended operations with the candidate missions through the co-occupant payload capability;
- O Flexibility to accommodate additional missions at very low costs;
- O Potential revenue to the Government from commercial use of the platform;
- O Domestic capability for U.S. commercial space R&D enterprises, and overall U.S. posture in "first to the market" space infrastructure.

Aside from these unique features, the RFP followed the normal procedures for a standard NASA competitive procurement.

### **III. FACTORS AFFECTING COMMERCIAL DEVELOPMENT OF SPACE PLATFORM SERVICES**

#### **A. Market Aspects**

Marketing any new product or service requires that a commercial enterprise identify potential customers and whether there is a real need for the product or service offered. In addition, several equally important considerations come into play, such as pricing strategy; the extent of the existing customer base and the potential for future growth; projected revenues and operating and development costs; the extent of the competition; and whether projected returns on investment are commensurate with the risk environment.

The market for space platform services consisted of potential use by commercial concerns interested in materials processing in space and a Government market - civil and military - for observations from space.

The high costs of getting to space and the risks associated with space activity had led Fairchild to conclude that products produced in space on their platform must be of a high cost per unit rate and must have potential annual sales of at least \$100 million. The few existing products which fit that description are the production of pharmaceutical products, crystals, precious metals, glasses and ceramics, metal alloys and deposits, and some specialty products. An overview of these products is presented below.

## 1. Pharmaceuticals

To date, the most promising commercial space processing activity appears to be the production of pharmaceutical products by the separation or purification of hormones and cells through continuous flow electrophoresis (EOS). By some estimates, the application of electrophoresis operations in space (EOS) to proteins and cells could result in yields 400 to 700 times than could be gained on the ground, as well as an improvement in resolution by about a factor of four.

MDAC began development of their EOS program employing the continuous flow process in 1977. Early shuttle flights in the 1982 to 1984 time period demonstrated the capability of the equipment to perform as predicted. With successful completion of their November 1985 flight, MDAC had the material to start the Food and Drug Administration clearance procedure for their first product. If they had been able to fly their commercial systems as planned in late 1986, by early 1987 they would have been in a position to draw final conclusions about the commercial potential and profitability of their first product, most likely erythropoietin. If the FDA had approved the product and it was demonstrated that it could be produced in sufficient quantities, domestic annual sales in excess of a \$100 million were projected by MDAC.

## 2. Crystals

Production of ultra pure, defect-free crystals was another promising space processing activity identified by Fairchild in their early marketing analysis. Fairchild identified four crystals that might be suitable for space manufacture. The first was gallium arsenide [GaAs] for use in microwave circuits and high speed processing. For the 1988 to 1995 time period, annual sales projections - based on the sale of five to forty kilograms at a price range of \$250,000 to \$600,000 per kilogram - were estimated at between \$3 million to \$10 million. Gallium arsenide would qualify as a potential space product on a price per unit weight basis, but not on the size of the projected annual sales (i.e below the \$100 million mark).

Cadmium telluride [CdTe] for use in infrared detector rays; indium phosphide [InP] for use in high speed single processing in fiber optic emitters and detectors; and mercuric iodide [HgI<sub>2</sub>] for use in gamma ray detectors were also identified as potential candidates for space processing. Like gallium arsenide, these crystals would all meet the requirement of price per unit weight, but would fall short of the \$100 million profitability mark, producing projected revenues in the \$5 to \$20 million annual sales range.

Research conducted on large organic crystals also suggests that they may be a potential candidate for space processing.

### **3. Glasses and Ceramics**

Examples of three high grade glass products that cannot be made on earth today are 1) high efficiency laser rod glass; 2) low impurity laser rod glass; and 3) pure fluoride glass fibers for communications. However, the extent of the market for these products is unknown.

### **4. Metal Alloys and Composites**

In a gravity present environment, metal alloys of different density are difficult to mix. This is because the heavier metal tends to separate from the lighter metal, thus resulting in an unequal distribution of the metals in the resultant solid. In a gravity free environment ( $10^{-6}g$ ), the density factor is removed, thus enabling metal alloys to be compounded into homogeneous mixtures. In theory, this process could result in extremely strong, yet light weight metal alloys of a type that cannot be found or produced on earth. Some possibilities include special catalysts, supermagnets, and high performance turbine blades. Again, no reliable market projections exist.

### **5. Other Market Possibilities**

One space manufactured product that is well advanced and has already produced sales is mono-dispersed latex spheres. Fifteen grams of ten micrometer polystyrene spheres have been produced on the STS-6 mission and are currently being offered for sale by the National Bureau of Standards. Production of the spheres however, is a rapid process, discounting the need for extended flight times such as that provided by Fairchild's Leascraft platform.

Government use of a commercial space platform, as identified in the NASA RFP, represented a considerable



element of the market for such services. Several missions, including two Explorer missions, the EUVE and XTE missions, a microgravity science mission, and a yet to be determined fourth mission were identified as candidate NASA missions in the RFP. The platform could also have been used as a test bed for sensor development, for land remote sensing, ocean remote sensing, meteorological satellites, Air Force projects, and some Strategic Defense Initiative projects.

In discussions with NASA and industry personnel, there is no question that many commercial firms were, and still are, interested in research in space. Their interest stems primarily from a desire to better understand the fundamental behavior of materials processes in space with the hope of improving ground-based manufacturing processes. From the initiation of the Fairchild Leasecraft MOU through the competitive procurement with RCA and Fairchild, MDAC was the only company with a comprehensive plan to produce a product in space. While several promising and potential commercial markets could be identified for a commercially owned and operated space platform, none of them - aside from MDAC's operations - fit the existing and present need for near term profitable operations.

## **6. Summary of Market Aspects**

Fairchild and RCA attempted to negotiate firm agreements with McDonnell Douglas as a major commercial customer for their respective space platforms. The negotiations with McDonnell Douglas were unsuccessful. In August 1985, Johnson & Johnson, the partner with McDonnell Douglas in the electrophoresis project, withdrew their participation, having found that a competing technology (genetic engineering) could produce the desired product on the ground at a price that would permit the early marketing. In 1985, MDAC decided they could meet their foreseeable processing requirements using the shuttle and was therefore no longer a near-term space platform services customer.

It is evident from the proposals submitted by both RCA and Fairchild that neither company had identified any commercial customer then willing to enter into any agreement for their respective space platform services, and both priced their services to NASA accordingly. Both companies proposed that if a commercial customer or other non-NASA Government program made use of their platform, NASA would be credited under formulas proposed by the contractors with revenues resulting from such uses. The lack of other non-NASA customers, whether commercial or Government, combined with the ground rule requiring the cost of the NASA procurement not be significantly greater than the traditional NASA method for carrying out the missions identified in the

RFP, substantially impacted the prospects of a successful price negotiation with either contractor.

## **B. Insurance and Risk of Loss**

Unlike the U.S. Government which acts as a self-insurer, commercial concerns generally obtain insurance against risks that may result in either claims against the company, or loss or damage to a revenue producing asset. The types of coverage planned for the proposed space platform services would have related to damage to, or loss of, the space platform during construction, transportation, or pre-ignition. The availability of insurance prior to launch has generally not been a problem. In addition to the pre-launch coverage, insurance against losses that might result during a shuttle launch, or while the platform is on orbit, is generally required by industry to protect its investment, or required by the financial institution providing financing for the development of the platform. In the past, insurance coverage has been provided through the space insurance market.

At the time of the NASA-Fairchild Joint Endeavor Agreement, and for a short period thereafter, insurance could have been obtained in the marketplace. In the 1983 time frame, shuttle launch and on orbit insurance rates ranged from 5 - 7% and could have been obtained at the time financing was being arranged for construction of the satellite. As a result of a series of communication satellite losses, the capacity in the market declined precipitously, particularly in 1985. Assuming coverage could be obtained in the amounts required (if obtained at all), coverage for launch and on orbit insurance increased to rates in excess of 20%. More importantly, coverage was not available until shortly before the scheduled launch - well after substantial investment had been made.

The sharp rise in insurance rates, restrictions, and availability led both RCA and Fairchild in their response to NASA's RFP to request that the Government become the insurer of last resort. This, in effect, shifted the risk of loss from the contractors to the Government. If insurance was available prior to launch the contractors would obtain it, but would expect the cost to be included in the contract price for services. At the time of NASA's request for best and final offers on the RFP, Fairchild was unable to obtain a commitment from underwriters for insurance.

If the RFP had been a standard NASA procurement for a NASA owned platform, the Government would have assumed the

risk of loss, thus eliminating the impediment imposed by insurance. In comparing the costs associated with the space platform services contract to the cost of carrying out the standard NASA approach of separate missions, the cost of insurance was not included in latter, though the imputed cost of money (interest) was. This had the net effect of inflating the commercial platform cost compared to a standard Government owned platform procurement.

Risk of loss, combined with the lack of a commercial market or other non-NASA government market, had a substantial impact on the prospects for a commercially owned and operated space platform.

### **C. Tax Related Factors**

Tax reform is currently under consideration in Congress and could have a major impact on private sector opportunities and initiatives in space. In addition, an Administration Interagency Working Group is also considering tax impediments to the commercial development of space. This section focuses on the impact of the tax laws from the time of the Fairchild - NASA MOU to the termination of the NASA RFP for commercial space platform services.

Rather than providing an incentive for private sector investment in space (particularly commercial facilities that would be used in space), Internal Revenue Code provisions in existence during the period identified served to discourage commercial investment in space when compared to other projects competing for capital investment. There is no investment tax credit [ITC] or accelerated depreciation [ACRS] available for assets used predominantly outside the United States. The applicable Treasury regulations adopt a "physical location" test for determining whether property is used predominantly outside the U.S., thus excluding assets used in space. In the case of communication satellites, there have been exceptions to this rule through IRS rulings and statutory amendments. Inclusion of non-communication, space-based assets however, would require legislative action.

A project's internal rate of return is seriously affected by tax provisions which require capitalizing certain costs that other projects can deduct. For example, the provision that permits current deductions of all research and development costs "in the year incurred" will generally permit a business to expense the cost of a prototype or pilot model of its planned product or asset. Reuseable spacecraft and space-based assets are so expensive, and the number of units in a program so small, that no commercial endeavor can

afford to build a prototype purely for test purposes. Typically, all of the design changes and improvements discovered in testing will be incorporated into the prototype and will generally be used either as a flight unit or spare. In such cases, the prototype hardware expenses must be capitalized and recovered over a period which commences when the asset is placed in service. If that date is five to seven years away, the internal rate of return of the commercial space venture will suffer when compared to a land-based investment rate of return.

Even the R&D tax credit passed by Congress in the Economic Recovery Tax Act of 1981 is of little or no benefit to the commercial space business. The Act requires that a company must already be in the space business to qualify, making it difficult for non-space businesses - such as the pharmaceutical industry - to qualify for credit. This, in turn, has an adverse impact on the the market for space platform services R&D. The Act also denies the credit to businesses that lease or license the results of their research to other firms, thus penalizing entrepreneurs that may lack the ability to bring a new space product to market.

Current tax laws do not allow the establishment of reserves for casualty losses for a commercial business, thus requiring the purchase of insurance to cover damage to, or loss of, the asset facility or product. While the tax code permits a business to take a yearly tax deduction for depreciation to provide funds for replacement of an asset, no similar yearly tax deduction is permitted to establish reserves for replacement due to casualty loss or damage to the asset. If tax deductible reserves could be established, they would be available for the replacement of a lost platform or other space facility thereby reducing the risk and financial impact of a loss in the event insurance was not available at any price. Insurance premiums for such coverage are tax deductible in the year incurred.

Though no evidence was found that tax considerations played a major role in causing the space platform services commercialization effort to flounder, existing tax disincentives make private investment in space activities less attractive than alternative opportunities.

#### **D. Space Transportation**

A predominant factor limiting the commercial platform market potential was, and still is, the high cost of transportation and cost of providing utilities in space. Both the platform operator and potential users must also have an assured source of transportation to and from space, and timely availability and reliability of transportation.

The RFP provision of initial free launch services was intended to assist the selected platform operator and commercial customers with entry into their respective markets by lowering their initial costs. However, for the space platform services contractor and potential commercial customers to establish prices and estimate the size of their respective markets, both had to consider transportation costs over a period of five to ten years.

From the contractor's point of view, pricing had to account for the cost of placing platforms in orbit, servicing them from time to time, and carrying, installing, and removing customer payloads. In the case of a materials processing manufacturer or commercial customer, transportation costs for raw materials or other payloads to and from the platform had to be included in the product or service pricing strategy. Once the initial free flights had been utilized, both the platform operator and customers had to plan on paying for transportation services at the rates NASA was likely to charge.

Transportation to the 260 nautical mile (Nmi) orbit proposed by Fairchild as the nominal orbit for their platform varies from \$15,000 per pound for a 2,000 pound payload, to \$1,837 per pound for a 52,000 pound payload. Using the cost of transporting a 20,000 per pound payload, the cost of transportation can be calculated in more common terms.

It costs approximately \$64 million to transport ten tons approximately 300 miles (260 Nmi), or about \$21,000 per ton-mile. Ground-based transportation, on the other hand, costs less than \$1 per ton-mile. In simple terms, transportation to and from space costs about 20,000 times the cost of ground transportation.

Although solar energy in space is free, the cost of transporting hardware to space to convert solar energy into electrical power is extremely high. Because of the large consumer base, electrical power on earth costs less than 0.10/KWH whereas on a space platform it costs about \$1,600/KWH. Or in the same simple terms, electrical power in space costs 16,000 times the cost of electrical power on the ground. Since electrical power is the principal utility required by a space manufacturer, the full cost of space platform services is significantly higher than a ground based facility producing the same product. Seen in this light, the high cost of transportation services to and from space had a negative influence on the potential market for space platform services.

The efficiency of a space-based manufacturing process, and its relationship to transportation costs, is another factor which impacts the market for platform services.

One measurement of the efficiency of an operation may be considered as the ratio of the weight of saleable products to the weight of the raw materials which must be carried into space to produce the product. For example, an inefficient system might be a small "purification" system which yields a 1% ratio of the weight of saleable products to the weight of the raw material needed to produce that product. Conversely, an efficient system might be a large "transformation" system capable of yielding an 80% ratio of the weight of saleable products to the weight of the raw material needed to produce the product. Another measurement of efficiency is the amount of power required to produce a given amount of material. An efficient system would be one that uses the full power capability of the platform, while an inefficient system would use only a portion of the platform's capability. A third measurement of efficiency is the amount of shuttle payload capacity utilized. An efficient system would use the full payload capacity, while an inefficient system would use only a fraction of the shuttle's capacity.

Under these assumptions, an efficient system would be the large "transformation" system (80%) which uses the full capacity of the platform and the full capacity of the shuttle for each launch. An inefficient system would be the small "purification" system (1%) which uses only a fraction of the platform capability and a fraction of the shuttle's payload capacity.

Assuming a platform customer requires the services of half a platform for a five metric ton processor (1% purification system), and the processor annually separates 1 pound of saleable products from 100 pounds of raw material, the annual transportation cost would be about \$20 million and platform lease and utilities about another \$25 million. The user with a small inefficient purification system has to pay a premium for operational costs when only a portion of the capacity of the shuttle and the platform are used. To break even with such a system, the customer must have an annual market of at least \$45 million for a product whose transportation and utility costs are over \$400,000 per pound.

In the case of a platform user with a highly efficient "transformation" system that uses the full capacity of the shuttle and the platform, the results are much different.

Assuming the user annually "transforms" 80,000 pounds of material into 64,000 pounds of saleable product (80% efficiency), the annual transportation costs would be \$140 million and the annual facility bill about \$50 million. The efficient user must have an annual market in excess of \$190 million for a product whose production costs are more than \$3,000 per pound.

Under both the inefficient and efficient scenarios, the impact of transportation and utility costs on potential customers (from the platform operator's view) and products (from the potential user's viewpoint) is to significantly narrow the range of market opportunities, both in terms of users and products.

Another way of analyzing the transportation costs is in terms of different platform operational altitudes. Table 1 shows the cost of transportation to and from 160 nautical miles (NMI), while Table 2 shows the cost of transportation to and from 260 nautical miles (NMI). Both tables appear on the following pages. It should be noted that the space station plans to operate at 260 nautical miles.

**TABLE 1**  
**LAUNCH COSTS TO 160 NMI ORBIT**

W Pounds	Launch Costs By Fiscal Year			Cost Per Pound		
	Y=1988	Y=1989	Y=1990	1988	1989	1990
2,000	3.84	4.00	4.15	1,921	1,998	2,077
4,000	7.68	7.99	8.31	1,921	1,998	2,077
6,000	11.52	11.99	12.46	1,921	1,998	2,077
8,000	15.37	15.98	16.62	1,921	1,998	2,077
10,000	19.21	19.98	20.77	1,921	1,998	2,077
12,000	23.05	23.97	24.93	1,921	1,998	2,077
14,000	26.89	27.97	29.08	1,921	1,998	2,077
16,000	30.73	31.96	33.24	1,921	1,998	2,077
18,000	34.57	35.96	37.39	1,921	1,998	2,077
20,000	38.41	39.95	41.55	1,921	1,998	2,077
22,000	42.26	43.95	45.70	1,921	1,998	2,077
24,000	46.10	47.94	49.86	1,921	1,998	2,077
26,000	49.94	51.94	54.01	1,921	1,998	2,077
28,000	53.78	55.93	58.17	1,921	1,998	2,077
30,000	57.62	59.93	62.32	1,921	1,998	2,077
32,000	61.46	63.92	66.48	1,921	1,998	2,077
34,000	65.30	67.92	70.63	1,921	1,998	2,077
36,000	69.14	71.91	74.79	1,921	1,998	2,077
38,000	72.99	75.91	78.94	1,921	1,998	2,077
40,000	76.83	79.90	83.10	1,921	1,998	2,077
42,000	80.67	83.90	87.25	1,921	1,998	2,077
44,000	84.51	87.89	91.41	1,921	1,998	2,077
46,000	88.35	91.89	95.56	1,921	1,998	2,077
48,000	92.19	95.88	99.72	1,921	1,998	2,077
48,750	93.63	97.38	101.27	1,921	1,998	2,077
50,000	93.63	97.38	101.27	1,873	1,948	2,025
52,000	93.63	97.38	101.27	1,801	1,873	1,948
54,000	93.63	97.38	101.27	1,734	1,803	1,875
56,000	93.63	97.38	101.27	1,672	1,739	1,808
58,000	93.63	97.38	101.27	1,614	1,679	1,746
60,000	93.63	97.38	101.27	1,561	1,623	1,688
62,000	93.63	97.38	101.27	1,510	1,571	1,633
64,000	93.63	97.38	101.27	1,463	1,522	1,582
65,000	93.63	97.38	101.27	1,440	1,498	1,558
EOS 22,500	43.22	44.94	46.74	1,921	1,998	2,077
LC 17,000	32.65	33.96	35.32	1,921	1,998	2,077

NOTE: These prices are base transportation cost. To these must be added the price for optional services, a planning charge of \$1.5 million per mission, and the cost of any upper stages.

EOS = MDAC Electrophoresis Operation

LC = Leasecraft Platform

PRICE =  $4/3 + [W/65,000] * (\$74M) * (1.04)$

\$74M = Price in 1982 dollars of dedicated shuttle flight

1.04 = Average annual rate of inflation over period 1982 - 1990

Y = Fiscal year of launch, prices in millions of dollars



**TABLE 2**  
**LAUNCH COSTS TO 260 NMI ORBIT**

W Pounds	Launch Costs By Fiscal Year			Cost Per Pound		1990
	Y=1988	Y=1989	Y=1990	1988	1989	
2,000	29.36	30.53	31.76	14,682	15,267	15,878
4,000	33.21	34.53	35.91	8,302	8,632	8,978
6,000	37.05	38.52	40.07	6,175	6,421	6,678
8,000	40.89	42.52	44.22	5,111	5,315	5,527
10,000	44.73	46.52	48.37	4,473	4,652	4,837
12,000	48.57	50.51	52.53	4,048	4,209	4,377
14,000	52.41	54.51	56.68	3,744	3,893	4,049
16,000	56.25	58.50	60.84	3,516	3,656	3,802
18,000	60.09	62.50	64.99	3,339	3,472	3,611
20,000	63.94	66.49	69.15	3,197	3,325	3,457
22,000	67.78	70.49	73.30	3,081	3,204	3,332
24,000	71.62	74.48	77.46	2,984	3,103	3,227
26,000	75.46	78.48	81.61	2,902	3,018	3,139
28,000	79.30	82.47	85.77	2,832	2,945	3,063
30,000	83.14	86.47	89.92	2,771	2,882	2,997
32,000	86.98	90.46	94.08	2,718	2,827	2,940
34,000	90.82	94.46	98.23	2,671	2,778	2,889
36,000	94.67	98.45	102.39	2,630	2,735	2,844
36,450	95.53	99.35	103.32	2,621	2,726	2,835
38,000	95.53	99.35	103.32	2,514	2,614	2,719
40,000	95.53	99.35	103.32	2,388	2,484	2,583
42,000	95.53	99.35	103.32	2,275	2,365	2,460
44,000	95.53	99.35	103.32	2,171	2,258	2,348
46,000	95.53	99.35	103.32	2,077	2,160	2,246
48,000	95.53	99.35	103.32	1,990	2,070	2,153
48,750	95.53	99.35	103.32	1,960	2,038	2,119
50,000	95.53	99.35	103.32	1,911	1,987	2,066
52,000	95.53	99.35	103.32	1,837	1,911	1,987
52,700	95.53	99.35	103.32	1,813	1,885	1,961
EOS 22,500	68.74	71.48	74.34			
LC 17,000	58.17	60.50	62.92			

NOTE: These are the base transportation costs. To these must be added the price for optional services and the cost of any upper stage

EOS = MDAC Electrophoresis Operation  
LC = Leasecraft

PRICE =  $(\$1.5M + 4/3 * (W + 12,300) / 65,000 * (\$74M)) * (1.04)$   
 \$74M = Price in 1982 dollars of dedicated shuttle flight  
 \$1.5M = Cost of planning a mission  
 \$10,800 = Weight penalty for lost tariff from 160 to 260 Nmi  
 1,500 = Weight of additional fuel required for higher orbit  
 1.04 = Average annual rate of inflation over period 1982 - 1990  
 Y = Fiscal year launch. Prices in millions of 1982 dollars

Clearly, the cost of transportation plays a critical role in shaping the size of the potential market for platform users and products. In addition, shuttle availability and schedule certainty are important. Interviews with industry personnel universally identified delay as a barrier to market entry since delayed launches, whether resulting from availability or schedule, impose an additional risk on both the space platform services operator and the space manufacturer. Under the terms of the RFP, NASA refused to accept the risk of liability for shuttle delay, imposing this risk on the space platform services contractor and its potential customers.

The lack of a replacement for Challenger will exacerbate the problems that have already been encountered while the shuttle was operating.

### **E. Termination Liability**

Termination liability can be generally described as the obligation of the buyer of the services or product to pay damages to the seller of the services or product if, for any reason, the buyer terminates performance under the contract.

In Government contracting, there are two forms of termination -- termination for the convenience of the Government, and termination for default. Under the standard termination for convenience clause, the Government, without explanation but acting in good faith, can terminate the contract. In doing so, the Government is liable for the payment of all incurred costs or liabilities arising out of the performance of the contract to the date of the termination notice, plus a reasonable profit for work performed, taking into consideration the percentage of work already accomplished.

Termination for default is a termination arising out of either the contractor or seller notifying the Government it will not perform, or the failure of the contractor or seller to perform in accordance with the terms and conditions of the contract. In a default termination the Government is relieved of any payments for any costs incurred by the contractor or seller and, in some cases, the contractor or seller may be liable for damages to the Government arising out of a reprocurement at a higher price for the same services or product.

In a standard Government procurement contract, unless funds are fully obligated, the contract usually includes a "Limitation of Funds" clause. This is the standard procedure in most NASA contracts performed beyond a fiscal year where multi-year funding would be required for

full performance of the contract. The Limitation of Funds clause requires a contractor to stop work at the point in performance where costs incurred by the contractor would exceed the funds obligated to the contract. The contractor assumes liability for costs of continuing performance after reaching this limit until such time as additional funds are obligated by the Government on the contract.

## **1. Termination under the JEA**

The NASA-Fairchild JEA contains a termination article covering both Phase 1 and 2 of the agreement and was a specially crafted article not found in a standard government procurement contract. In Phase 1, neither Fairchild nor NASA would have been entitled to any compensation as a result of termination. Neither party would have been required to transfer any data information, patents, or other results of work accomplished or in progress other than those agreed upon as a result of negotiations. In Phase 2, Fairchild could have terminated unilaterally for any reason by giving NASA written notice. In the event of a termination, NASA would be entitled to purchase and take title of all flight hardware, related software, and support equipment - completed or in process - at the cost incurred by Fairchild together with any license rights to any patents and data that might be required. Under very limited circumstances, NASA had the right to unilaterally terminate the agreement. If NASA did choose to terminate, they would not be obligated to reimburse Fairchild for costs incurred.

In light of the Challenger accident, it is important to note that NASA agreed that it would not terminate the agreement for reasons beyond NASA's control unless there was a resulting cessation of shuttle launches for commercial purposes for a substantial period of time. NASA did, however, agree that as an option to terminating the agreement it would consider postponing a payload launch.

Termination did not create a barrier in the negotiation of the Joint Endeavor Agreement and Fairchild assumed the entire risk that it might not obtain the free launches agreed to by NASA. In the JEA, however, NASA did not agree to procure platform services. Any such procurement would have been in a form of a standard procurement contract containing the usual termination for convenience and default clauses.

## **2. Termination under the Unsolicited Proposal**

Though the unsolicited proposal submitted by Fairchild never went beyond the preliminary discussion

stage, there was a termination liability clause included in the proposed contract for services.

Under the provisions of the proposal, NASA, in the event of a unilateral termination, assumed termination liability under a fixed payment schedule in fixed amounts extending over the period of the agreement. The proposed termination agreement provided that a NASA convenience termination could be triggered by Fairchild if its first commercial customer (presumably MDAC) terminated its contract with Fairchild and Fairchild could not find another customer. Under the latter provision, Fairchild was attempting to shift the market risk for commercial customers to NASA. Similar to a standard procurement termination, the termination for convenience clause in the unsolicited proposal required Fairchild to transfer title, and turn over all hardware and works in process and any data that generated by the performance of the contract.

It was NASA's view that the unsolicited proposal did not permit NASA to exercise a default termination but, instead, granted NASA limited rights for what would be called "outage" penalties, (i.e., a reduction in the price to be paid as a result of failure to fully provide contract services).

### **3. Termination under the RFP**

The RFP set forth an outline of quarterly schedules establishing the cumulative maximum liability the Government would incur in the event of a termination for convenience. The schedule provided for a maximum termination liability for each undelivered service month and stated, notwithstanding any amounts listed, nothing in the RFP or contract should be construed as making the Government liable for any amount exceeding actual appropriations in relevant program areas or for appropriations sufficient to fund such liability. NASA's best estimate of the amount that would be available to fund termination liability was promised to all offerors before the time of the final proposal. Because the contract was a procurement of services and not hardware, the Government would not automatically get title to platform parts and materials since they would not have been acquired specifically for a NASA service, but, instead, were being acquired to provide services to NASA as well as other commercial customers and/or other Government agencies. Since NASA would not obtain title in the event of a NASA termination for convenience, , NASA did not expect the contractor to propose NASA pay all costs associated with the entire effort, or to propose termination liability based on a 100% of all incurred costs. NASA did expect the contractor to propose an "equity" factor in the termination

proposal schedule. In other words, NASA expected the contractors to assume the risk of obtaining additional customers other than NASA - whether Government or commercial - and based upon this assumption of risk, NASA would receive appropriate credit in the termination schedule.

Neither Fairchild nor RCA proposed an "equity" value in their termination schedule, preferring instead to leave the issue of credits NASA would receive towards its termination payments open to future negotiations. In the event such termination would occur, other factors, such as the date of termination and the circumstances at the time, would come into play.

As no final proposal was submitted or final negotiations conducted on the RFP, it is impossible to project what the outcome of the termination issue might have been. However, based on interviews conducted in the course of this study, and an analysis of the proposals as well, there appears to have been a willingness on the part of one of the contractors to propose a significant "equity" factor enabling a resolution of the termination issue that would have been satisfactory to both NASA and the contractor.

## **F. Institutional Barriers**

### **1. The Source Evaluation Board Process**

An examination of the Source Evaluation Board (SEB) documentation, composition of the SEB and its committees, and interviews with participants in the selection process, leads to the conclusion that any prejudice against using a space platform services contract - as opposed to the use of individual Explorer missions - had been minimized to the maximum extent possible.

The platform services approach represented a change in the way previous Explorer programs had been run. In the past, an Explorer mission would normally continue operation until its performance degraded at no additional cost to the Government except the cost of operation. Under the platform services concept, operation of a mission would terminate at the end of the service contract or NASA would have to purchase additional services from the platform operator. The possibility of institutional resistance to that change was real; however, the selection process served admirably in minimizing any such prejudice.

A related institutional concern is whether the difficulties that occurred during the administration of the Tracking and Data Relay Satellite System procurement (TDRSS)

might have negatively influenced attitudes at Goddard in proceeding with another mixed Government / commercial facility. The standard Goddard procurement normally includes "in-house" technical direction and influence on the design or manufacture of a spacecraft. Such technical direction was lacking in the TDRSS contract and would have been lacking in the space platform services contract. The lack of ability to technically direct the TDRSS contractor was a major cause of conflict during the performance of that procurement. Based on a review of related documents and interviews, it is clear that any such impact in the platform procurement had been minimized through the selection of the SEB members and committee members well as the manner in which the SEB evaluation had been conducted. In addition, it is evident that every effort was made to run a fair and proper evaluation of the proposals including detailed analysis of the relative costs and advantages of separate Explorer missions versus the use of the space platform services contract.

The ground rules utilized in the SEB selection process were not reviewed by Senior Management at NASA Headquarters. More careful review of the ground rules may have avoided the inconsistency concerning whether or not the reviewers were to consider the value of fostering future commercial endeavors as part of the selection criteria. One ground rule explicitly states that the SEB was not to consider this aspect while another states that "domestic capability for U.S. commercial space R&D enterprises, and overall U.S. posture in 'first to the market' space infrastructure" should be considered within the context of the evaluation.

The Office of Commercial Programs played no role throughout the attempts to develop a commercially owned and operated space platform service. This was either because the Office was not established at the time ( the Office was established in November, 1984), or in the case of the competitive procurement, it was too far along and the Office was too new to substantially participate in the activity. If the Office is to be an effective advocate for the commercialization of space and to be charged with implementating the policies announced by the Administration, Congress and NASA, it must play a major role in commercialization efforts in coordination with any affected Program Office or Center.

## **2. Funding Procedures**

Funding procedures followed by NASA and Congress can be viewed as barriers to commercialization where the Government is either the first customer or prime customer for the commercial goods or services .

The lack of certainty of government funding for the entire contract period makes it difficult, if not impossible, to market the platform to potential commercial users, particularly when the market is limited and the platform would be the only extended stay facility until the space station became operational. A company interested in space manufacturing requiring such long stay time would require some assurance that the space platform would be developed and constructed irrespective of whether the Government terminates or not. Such a customer would not be interested in making any large capital investment without such assurances. A space platform manufacturer would not give those assurances because, if the Government was to terminate mid-stream, there would not be sufficient revenues flowing from the other customers to justify the continuation of the project. More than likely, any contract with a potential commercial customer would contain a provision that if the Government were to terminate its program, then the space platform manufacturing contractor could terminate its contract with a commercial customer without any liability for the payment of damages to the commercial customer. The reason why such a clause was included in the unsolicited proposal by Fairchild was that the price being offered to NASA was based on continued revenue from McDonnell Douglas. The lack of such revenue from McDonnell Douglas would have made the unsolicited proposal unprofitable for Fairchild. Thus, the uncertainty that, at some stage, a program might be discontinued and the government contract terminated for the convenience of the Government, tends to act as a negative factor in stimulating commercialization of space.

Current NASA funding and Congressional procedures make no provision for the value of a private sector company providing a commercial, privately financed space facility for use by both the Government and other commercial customers. The ground rules for the procurement of platform services required the cost or price of the platform services to be less than, or equal to, the funding available or anticipated from approved projects or anticipated new starts. There was no willingness on NASA's part to place a dollar amount on the value that developing a commercial space platform would have on encouraging the development of a space manufacturing industry. Just as the contractor's refusal to accept a substantial portion of the market risk negatively impacted the commercial platform concept, so did the Government's refusal to recognize the value of seeing the project through in relation to future commercialization initiatives by the private sector. If the development was successful and other commercial customers began to use such a facility, in the long run the Government would have recovered that value through lower prices. The only way that additional funds could be made available to fund commercialization initiatives - as initiatives with a recognized value beyond short term

returns - would be from other NASA programs. At a time of tight budget constraints within NASA, there is an inherent institutional barrier to NASA transferring funds from other approved programs to new programs which are deemed to have a value in fostering commercialization of space. Compounding this problem is the fact that under current Congressional and NASA procedures, authorizations and appropriations done on a fiscal year basis do not fully fund NASA's programs.

## G. Procurement Laws and Regulations

Another barrier rests with existing procurement laws, regulations and procedures. In contrast to the flexibility afforded NASA under Section 203 (c) (5) of the National Aeronautics and Space Act, procurement laws, regulations and procedures require - with very limited exceptions - full and open competition. Public Law 83-36, 98-525 and 98-577 recently enacted by Congress have made it more difficult for NASA to accept unsolicited proposals or to make sole source awards.

NASA, in a report to the Chairman of the House Committee on Science and Technology (August 29, 1985) stated:

In view of this, we are not aware of procurement authority which would, per se, authorize, in the selection process, a preference for commercial ventures or the encouragement of such ventures. Thus, NASA's promotion of commercial ventures in the procurement context has been necessarily constrained.

Using the procurement process is time consuming as well as inflexible. The procurement laws have been interpreted and applied so as to require NASA and other Government agencies to set forth technical requirements in great detail. Once proposals have been submitted, and without reopening the competition, there is little room for innovative ideas or approaches which deviate from the the RFP requirements but may be more beneficial to the Government.

The requirement for competitive selection where there is a known Government requirement discourages companies from identifying space facilities that could be developed by the private sector. It makes no financial sense for a company to expend its funds to design a facility only to have the Government then decide to seek a competitive procurement. It is unrealistic, to expect the private sector to fully initiate a program of research leading to final design and development with the prospect of competitive selection enforced in the final stages.



#### IV. SUMMARY

Any one or more of the factors outlined above can be cited as a reason why the commercial development of space platform services failed. Based on interviews and a review of the documentation, two salient factors "doomed" the commercial space platform concept. Both of these factors were beyond the control of either NASA, Fairchild, or RCA.

The first was the lack of an existing non-Government market and, in particular, the withdrawal of McDonnell Douglas, the one commercial concern well along in the development of space manufacturing of pharmaceuticals. With MDAC's withdraw from the market, NASA was the sole customer for what was to be a primarily commercially oriented venture.

The second factor was the reduction in available insurance resulting from catastrophic losses occurring in the space insurance market in 1984 and 1985. Both of these factors, and NASA's position that it would not assume the risk of loss of the space platform during launch or on orbit, resulted in a situation where the expected costs to NASA of procuring commercial space platform services substantially exceeded the cost of conducting its missions as individual and separate missions. From the contractor's point of view, the substantial investment required could not be justified in terms of the risks. In simple terms, the space platform services procurement was viewed both by NASA and the contractors as a "bad deal".

**SECTION II**

**RECOMMENDATIONS**

## I. INTRODUCTION TO RECOMMENDATIONS

No set of recommendations - including those presented here - can be applied in each instance to each and every commercialization effort. In some cases, all that may be required is the support currently being provided by NASA under the various forms of agreements that already exist. For example, in the case of the commercial development of the Payload Assistance Module -Delta (PAM-D), all that was required was some technical assistance and permission to use government property. Or, in the case of the Payload Assistance Module - Atlas (PAM-A), the purchase of several units was required. In other cases however, more extensive forms of assistance - such as free shuttle flights - may be in order. The recommendations contained in this section and those that follow are directed to the Administration, Congress and NASA.

### A. The Market Risk

While final negotiations did not take place with either Fairchild or RCA on the competitive procurement, NASA would not have entered into a contract with either corporation at the prices initially proposed. The prices offered by both contractors far exceeded the cost of separate missions. It is apparent from a review of the documentation and interviews, that neither company was willing to assume the market risk of acquiring additional non-Government or other Government agency customers who would use platform services. This lack of confidence by the proposers that there was neither an existing market nor a near-term potential market for platform services other than NASA, was sufficient reason for NASA not to proceed with this procurement. In interviews with senior personnel of one of the contractors this was accepted as a valid reason for NASA not proceeding with the commercialization effort.

There may be occasions when NASA should be willing to share the market risk with the supplier of goods and services to promote the early development of a commercially financed, owned, and operated space facility that would be used by other government agencies or by the private sector. This may require the Administration, Congress and NASA to approve funds for this purpose over and above the basic NASA budget request. Any such "equity" or "commercial value" would be recouped by NASA from non-NASA sales by the commercial developer to other private sector entities or other Government agencies.

## **B. Insurance and Risk of Loss**

The lack of insurance coverage clearly prevents entrepreneurs from entering the space commercialization market whether it be the development of space platforms, communication satellites, or other space facilities. It is also part of a broader problem affecting many other industries in the United States. The simple, straight forward solution that has been proposed by the contractors that were involved in the space platform services procurement, as well as others, is for the Government to become the insurer of last resort. It has done so in the past on many occasions. Some examples are flood insurance, crop insurance, and the Price-Anderson Act applicable to the nuclear industry, to name just a few. Congress could pass legislation to provide coverage for commercial activities in space or such coverage could be provided in a broader bill covering other industries as well.

The Administration or Congress could also change the tax laws to permit the establishment of tax deductible reserves for damage or loss of property. Such reserves would be tax deductible during the construction of the space facility. The reserve would be reduced, once the asset was put into use, by the amounts deducted for depreciation in subsequent years. Insurance premiums are currently an allowable business expense.

Such reserves could be established only upon a showing to the Internal Revenue Service that insurance coverage was either unavailable or was available at a premium which would be unreasonable in light of the prior claim experience of the company.

The two previous solutions that have been suggested are so broad and involve so many policy considerations that they could not be adopted in the near term. There is however, a potential solution for the narrow case illustrated by the space platform services commercialization effort. It deals with the situation in which NASA is the predominant customer for the space services or goods that are being commercially developed, or where NASA is the initial customer but has determined that future commercial markets for such goods or services would develop.

It is the general policy of the U.S. Government to self insure its activities and its property. Based on this policy, when NASA procures an asset for its own use through the procurement process, it assumes the entire risk of loss after completion of the contract and delivery. In the case of the procurement of a separate platform for an Explorer

mission, under normal procurement procedure NASA would assume the risk of a satellite being damaged or lost during launch or on orbit. In the case of TDRSS, and in accordance with the policy of self insurance, NASA directed the contractor not to insure that portion of spacecraft cost that was attributed to government use. The contractor was free to insure the portion of the investment in the spacecraft that was dedicated to commercial use. The reason for this was that NASA was following the policy of self-insurance and did not wish the cost of insurance for the government portion of the program to be included in the price for the services to be rendered after launch and when the TDRSS was on orbit. There is evidence to suggest that NASA's sharing of the risk in the TDRSS case was linked to a high level of interest within senior NASA management levels in the success of the venture. Neither the Challenger, the TDRSS on board, nor other government satellites and property on board the orbiter were insured against loss or damage.

Because of the high capital investment required for the commercial development of a space facility, the risk of loss during launch or on orbit is substantial and, unless resolved by the insurance industry, the Administration, Congress or NASA, it will continue to be a major barrier to the development of commercial activities in space. The possibility of sharing the risk of loss in the space platform services procurement was never explored. In the future, and as part of these recommendations, in some instances NASA should share risk of loss with the commercial developer. This option should be explored more thoroughly. If there are one or more non-NASA customers for the facility that is to be commercially developed, the risk of loss could be shared by NASA, the proposer of the commercial facility and one or more of the additional customers, whether they be private sector or other Government agencies.

### C. Tax Treatment

The unequal treatment of space commercialization investments received under the tax laws and regulations is a disincentive to industry to invest in the commercial space initiatives.

If a company must choose between two investment opportunities - one being a space commercialization facility project and the other an asset based within the territorial limits of the United States - and both projects are of an equal amount and equal market potential, the current tax laws give preference to the ground-based investment. The tax reforms under current consideration may result in equality of treatment at least in the areas of incentive tax credits

and accelerated depreciation. The lack of an R&D credit will remain a disincentive for businesses wishing to enter space commercialization industry.

Private sector initiatives aimed at the commercial development of space should receive equal, if not preferential, treatment under the tax laws and regulations.

#### **D. Space Transportation**

The JEA provision of free flights represented a very substantial financial incentive to the commercial development of the Leasecraft Platform proposed by Fairchild. In order to equalize the opportunity for competition, NASA decided to include the free flights in the competitive RFP. However, the approximate \$2,000 cost per pound for transportation had (and still has) a significant effect in limiting the market available for commercial use by materials processing concerns.

The recent National Commission on Space report recognized the need to reduce the cost of transportation if the exploration and exploitation of space for commercial and other purposes is to be achieved. The Commission recommended that the cost of space transportation be reduced from the approximate \$2,000 per pound to \$100 per pound. All forms of transportation in this country have received and are continuing to receive some form of government support. Rail transportation received rights-of-way and mail subsidies. Air transportation receives air traffic control as well as having received mail subsidies. Water transportation, both for inland and ocean faring transport, receives Government support. On a comparative basis, at a minimum, space transportation should be given equal consideration and receive such support.

Congress and NASA should explore the question of reduced transportation costs with the materials processing industry, focusing on what effect, if any, a reduction of transportation costs would have on expanding the market. Another approach would be to expand the use of Space Services Development agreements with materials processing concerns as well as others who offer to develop commercial facilities. This approach, rather than being a direct form of subsidy, would require repayment, whole or in part, of the launch services furnished by NASA; in effect creating a partnership between those industries and the Government.

## **E. Schedule Uncertainty**

Schedule uncertainty is a risk that has been identified by industry as a major barrier in determining whether to invest corporate funds in space commercialization.

The standard Launch Services Agreement relieves NASA for any delays, and the communications satellite industry has accepted it. The communications satellite industry, however, is a well-established industry with a well-established market and, in most cases, delay does not have a major impact on the revenue flow. In the past, the communications satellite industry could obtain satellite life insurance which further minimized this risk. The reason for the adoption of this policy by NASA as applied to commercial communications satellites is if NASA were to be liable for damages caused by delay, then those damages would have to be paid for out of other NASA programs or by additional Congressional appropriations - thus creating another institutional barrier to the acceptance of such a risk.

However, NASA does assume the risk of delay when it is a standard government procurement for goods or services to be provided to NASA as the sole customer, whether the contract is a cost reimbursement or fixed price contract. NASA did pay for shuttle delays that impacted the TDRSS program and it is currently paying for delays brought about by the cessation of government launches in such programs such as Galileo, the Space Telescope and others. The situation is therefore the same as exists for termination liability and risk of loss.

The solution may again be a sharing of the risk of delay in commercial space initiatives. In addition, and to the maximum extent possible, NASA must exert its efforts to shorten the time period between when a request for a Joint Endeavor or a unsolicited proposal is submitted, and when an agreement for the procurement of the Government services or product is reached.

## **F. Termination Liability**

A proposer of a commercial development facility should be willing to assume a portion of the termination liability. Such was the case in TDRSS where NASA only assumed the termination liability for the Government's portion of the spacecraft. Whether the sharing ratio should be the same for market risk, risk of loss, and termination liability is a question worthy of a more in depth study. A provision could be negotiated that in the event non-NASA use of the facility increases - thus reducing the percentage of NASA use of the

facility - adjustments could be made reducing the NASA liability for termination or risk of loss. It would stand to reason that by initially sharing the market risk, as the market expands, NASA would benefit through the reduction of costs for the services being performed for NASA.

The recommendations outlined in the areas of sharing the market risk and the risk of loss, are equally applicable to sharing termination liability.

## G. Institutional Barriers

One institutional barrier of prime importance is the priority to be afforded in the Administration, Congress, and within NASA to the commercial development of space. The importance of NASA senior level involvement in the commercialization effort can best be illustrated by the TDRSS experience. The TDRSS request for proposal and resulting contract was the first effort by NASA to obtain commercial services that would be available to both NASA and to non-Government users. The TDRSS procurement is not without controversy. It is used here only to illustrate what can be accomplished when a program receives senior level management attention, direction and support.

The TDRSS procurement received the attention, direction and strong support of the then Administrator of NASA, other senior officials at NASA headquarters, and the Goddard Space Flight Center Director. Most of the factors on which agreement could not be reached between NASA and the contractors in the space platform services procurement were satisfactorily resolved during negotiations with Western Union, the successful proposer on TDRSS. The same degree of senior level NASA support will be needed if future commercial initiatives are to succeed. Currently, the Office of Commercial Programs is the organization in NASA responsible for, stimulating, encouraging, and supporting commercial initiatives in space. It cannot, however, do the job alone.

NASA, as an organization, must fully support the commercialization effort. That includes the Administrator, the Associate Administrators and the Center Directors. When a potential commercial development is identified by NASA or proposed by industry, it is important that the Administrator, Program Directors, Associate Administrators and Center Directors review their programs to identify potential Government participation through the purchase of services or product by those organizations.



## H. Procurement Laws and Regulations

Another barrier is the application of the procurement statutes and regulations to commercialization proposals submitted to NASA either through a request for a Joint Endeavor Agreement or the submission of an unsolicited proposal. The Competition in Contracting Act and the regulations implementing that act make it extremely difficult for NASA to go sole source or accept an unsolicited proposal for a government requirement. Congress amended the NASA Act declaring that the general welfare of the United States requires that NASA "seek and encourage, to the maximum extent possible, the fullest commercial use of space." If NASA is to carry out that mandate, it is absolutely necessary that when an innovative commercialization idea is presented to NASA - by way of a Joint Endeavor or an unsolicited proposal - NASA is free to identify potential government uses and not be unconditionally bound by competitive procurement subsequent to the presentation of the idea. To do otherwise, will discourage the development of innovative commercialization approaches.

When a Joint Endeavor Agreement or an unsolicited proposal proposes a product or service that could be used by both Government and non-Government users, and after identifying the Government uses in accordance with the previous recommendation, NASA should negotiate a contract with such offeror for the procurement of the Government services assuming agreement on price can be reached.

Where NASA has identified a facility, product or service that can be used by NASA and other non-Government customers, NASA should seek expressions of interest from the private sector for the commercial development of such a facility, product or service. Rather than employing the standard NASA procurement procedures, NASA should develop procedures permitting greater flexibility in stating its requirements, negotiating final agreements, and reducing the lead time for a contract award. NASA developed the Announcement of Opportunity procedures to meet its unique needs for experiment selection. Commercialization of space is sufficiently unique so as not to lend itself to the normal NASA procurement process. Pending the establishment of such procedures and pending clarification of NASA's authority under the Space Act, NASA should review its selection criteria and SEB scoring system recognizing the importance of space commercialization.

Where other major non-Government customers have been identified who would use the service or buy the product, NASA - with the permission of the supplier - should contact such non-governmental customers to negotiate as a team with the supplier in those situations where it is highly unlikely

that the commercialization effort could proceed without the Government and the non-Government purchase of the goods or services. This provides the opportunity for the three parties to allocate and share the substantial risk involved in space commercialization.

The General Counsel's office should review the authority of NASA to carry out the above recommendations under the authority of the Space Act, Section 203 (C) (5), taking into account the decision interpreting that section in the case of *AFGE vs. Paine*. In the event the General Counsel determines that NASA lacks the authority, then it is recommended that Congress enact legislation to grant NASA the authority to implement this recommendation.

### **I. Funding Procedures**

A major complaint voiced by industry was the uncertainty of NASA's annual funding process. While full funding would not, in and of itself, prevent the termination of the NASA project by either the Administration or Congress, it does provide greater assurance to industry investing its own funds in commercialization efforts.

Congress, in concert with the Administration and NASA, review the funding procedures normally used for NASA projects to see whether, as a matter of policy, those procedures should be changed to encourage and support space commercialization activity. Specifically, all three entities should consider granting NASA authority relieving NASA of the requirement to obligate funds for the contingent liability of a convenience termination. Also, NASA projects associated with a commercialization effort should be fully funded through appropriations and authorization rather than on a fiscal year basis.

### **J. Financing**

Congress may wish to consider the advisability of providing such financing or guarantee to entrepreneurs. Such financial assistance would encourage small entrepreneurs and non-aerospace companies to consider investment in commercial space initiatives.

The Congress may wish to reconsider HR7412 introduced to the 96th Congress Second Session, to establish a Space Industrial Corporation to promote, encourage, and assist in the development of new products, processes, services, and industries using the properties of the space environment and

in the use of space technology.

H.R. 7412 was introduced in the House of Representatives on May 21, 1980, co-sponsored by Mr. Fuqua Mr. Roe, Mr. Winn, Mr. Goldwater, Mr. Scheuer, Mr. Hollenbeck, Mr. Dornan, Mr. Lloyd, Mr. Walker, Mrs. Bouquard, Mr. Blanchard, Mr. Flippo, Mr. Ritter, Mr. Watkins, Mr. Young of Missouri, and Mr. Nelson.

## II. CONCLUSION

The commercial development of space is within its infancy and in some cases in its gestation period. It is an area of activity that requires high capital investment and high risk, while other competing ground based investment opportunities offer significantly lower risk. It is an area that, at present, offers a only a limited or even unknown market potential. Also, it is an area with no industry experience base or proven "track record". Lastly, it is an area that, in many cases, will require the development of new technologies but in doing so will contribute to United States leadership in space and new technologies.

The Administration, the Congress and NASA all publicly support the concept of space commercialization. If space commercialization is to succeed, there must be tangible evidence that all three entities will support the concept with clear objectives and commitments. On the industry side, the private sector must be willing to make the capital investment and to assume or share with the Government some of the risks associated with the development of a new industry and new markets. The Government cannot and should not assume all the risks of space commercialization. Considering the risk involved and the current status of space commercialization, a contractor cannot and will not assume all the risks in order to enter the market. The Administration, Congress, and NASA can remove some of the institutional and other barriers that inhibit the commercialization of space. Other nations appear willing to support their industry in one way or another either through subsidies or through entering into equity relationships with their industry.

In view of the recognized importance of space commercialization, the U.S. Government should at least be willing to share and reduce the risks involved in commercial space activities at this stage in its development.

**APPENDIX 1**

**CHRONOLOGY OF EVENTS**

## Chronology of Events

DATE	EVENT
1977	McDonnell Douglas flies Electrophoresis (EOS) Experiment on STS.
1981	FC and Goddard independently conduct feasibility studies on possibility of using MMS for EOS experiments. Conclude that power requirements and cost of compatibility with STS warrant new system.
1982	Fairchild establishes Space Operations Company to market services of Leascraft.
8/82	NASA and Fairchild sign MOU with Letter of Agreement attached.
8/83	NASA and Fairchild sign JEA .
4/84	Fairchild submits unsolicited proposal to NASA for services of Leascraft.
9/84 *	Fairchild submits firm fixed price contract to MDAC for services of Leascraft and begins negotiations for services.
12/84	MDAC and Fairchild suspend negotiations.
9/84	NASA declines Fairchild's unsolicited proposal. Decides to procure services through competition.
11/84	RFP Pre-release.
12/84	Procurement plan approved.
1/85	Source Evaluation Board (SEB) appointed.
1/85	NASA issues RFP 5-14000/357 for Space Platform Services.
1/85	Preproposal conference attended by 15 companies.

2/85 Amendments 1 and 2 to the RFP issued.

Amendment 1 revised payload module power loads and Section L of RFP; deleted requirements for unpriced elements of cost; and responded to submitted questions.

Amendment 2 revised delivery schedule in Article F-1, the Technical Proposal Instructions, the Specification for Platform Services; updated requirements for Micro-Gravity Science Mission; added EUVE data requirements.

3/85 Amendment 3 to the RFP issued, revising the proposal due date and packaging.

3/85 Fairchild and RCA respond to RFP.

5/85 Initial proposal evaluation completed.

6/85 Competitive range determination. RCA judged to be outside competitive range

7/85 Orals held by NASA.

7/85 \* Fairchild resumes discussions with MDAC.

8/85 MDAC notifies Fairchild that they have no foreseeable future need for Leasecraft services.

9/85 NASA issues letter requesting best and final proposals.

10/85 Fairchild declines to submit a final proposal.

11/85 NASA formally terminates the RFP.

12/85 Fairchild submits a report to NASA on a "Survey of the Market for the Services of Small Privately Owned Space Platforms (LC 085-01).

\* Approximate date

**APPENDIX 2**

**NASA - FAIRCHILD MEMORANDUM OF UNDERSTANDING**

ORIGINAL PAGE IS  
OF POOR QUALITY

MEMORANDUM OF UNDERSTANDING  
AMONG  
FAIRCHILD INDUSTRIES, INC.  
AND  
THE NATIONAL AERONAUTICS AND SPACE ADMINISTRATION  
CONCERNING THE DEVELOPMENT AND COMMERCIAL  
AVAILABILITY OF A SMALL SPACE PLATFORM

PREAMBLE

The National Aeronautics and Space Act of 1958, declares that the aeronautical and space activities of the United States shall be conducted so as to contribute to the preservation of the role of the United States as a leader in aeronautical and space science and technology and their application to the conduct of peaceful activities within and outside the atmosphere. The furtherance of these activities may be substantially enhanced by the early availability of a shuttle-launched and supported mobilemini space platform furnishing the necessary utilities (space, power, stabilization and communication) for these activities. The Administration and NASA are committed to a reliance on the private sector for the supply of needed commercial products and services whenever possible. NASA is, therefore, interested in a commercial firm opting to design, develop, and provide such a platform to users through lease or purchase.

Fairchild Space and Electronics Company (FSEC) believes there is an increasing number of commercial institutions moving toward the use of space and space technology for the production of goods and services for profit. Fairchild wishes to create a commercial entity to lease to governmental and commercial users a variety of space systems, spacecraft, and space platforms launched, serviced, and retrieved by the Shuttle. Such a commercial entity could also supply a variety of technical and administrative services such as the integration of the user's hardware with the spacecraft or platform, integration of such a spacecraft or platform with the Shuttle, and provision of the necessary documentation and technical support to the user and to NASA for the launch, operation, services and retrieval of the users' products and/or hardware. Fairchild recognizes the need for a substantial investment to create such an entity and its shuttle-compatible hardware and the investment will be at a considerable risk for a number of years. Fairchild believes that the possible returns from the already planned governmental and commercial space activities, together with the coming industrialization of space justify much of that risk. Fairchild believes that its experience with the shuttle-compatible Multimission Modular Spacecraft (MMS) places it in a unique position to assure the technical success of such an enterprise, and to succeed in this respect of the commercialization of the Shuttle.



THE UNDERSTANDING

NASA and Fairchild Industries, having a mutual interest in the development and commercial availability of a small space platform, and associated services, based upon MMS technology, agree to explore the feasibility of an agreement on a joint endeavor to bring such a platform into being, demonstrate its capability in 1986 and have it commercially available for Governmental and commercial users for at least 10 years beginning in 1986.

It is expected that any such endeavor would proceed in three (3) phases: (1) a feasibility and preliminary design phase in FY 1982; (2) a development phase extending from CY 1983 through CY 1986, with a six-month in-orbit demonstration in CY 1986; and (3) an operational phase from CY 1987 through CY 1996. No exchange of funds between NASA and Fairchild Industries would be expected in Phases 1 and 2.

It is further expected that such a small space platform would be capable of supporting appropriate scientific and space applications missions.

NASA and Fairchild each agree to designate an individual to be responsible for pursuing the agreements reached in this Memorandum of Understanding.

The undersigned agree to review jointly the status of the endeavor no later than September 1, 1982. While pursuing this endeavor representatives of NASA and Fairchild will agree on procedures regarding publicity and the maintenance of proprietary information where necessary and appropriate.

NATIONAL AERONAUTICS AND  
SPACE ADMINISTRATION

FAIRCHILD INDUSTRIES, INC.

APPROVED: 

James M. Beggs  
Administrator

APPROVED: 

Edward G. Uhl  
Chief Executive Officer

DATE: AUG 27 1982

**APPENDIX 3**

**NASA - FAIRCHILD JOINT ENDEAVOR AGREEMENT**

**AND**

**SEPARATE LETTER OF AGREEMENT**

**ORIGINAL PAGE IS  
OF POOR QUALITY**

AGREEMENT BETWEEN THE  
NATIONAL AERONAUTICS AND SPACE ADMINISTRATION  
AND  
FAIRCHILD INDUSTRIES, INCORPORATED  
FOR A JOINT ENDEAVOR CONCERNING THE  
RESEARCH AND DEVELOPMENT OF A SMALL  
SPACE PLATFORM FOR COMMERCIAL OPERATIONS

LETTER AGREEMENT BETWEEN NASA AND FAIRCHILD  
REGARDING THE NASA/FAIRCHILD JOINT ENDEAVOR AGREEMENT

The purpose of this Letter Agreement is to record actions which must be jointly taken by NASA and Fairchild in order to carry out the intent of the Joint Endeavor Agreement (JEA) and help establish the commercial viability of Fairchild's Leasecraft venture. These actions are not part of the NASA/Fairchild Joint Endeavor Agreement JEA proper because they relate to possible commitments which may extend beyond the term of the JEA. However, action to resolve these issues must be taken during the term of the JEA and decisions taken on the schedule indicated.

- A. Fairchild and NASA shall jointly and expeditiously examine the technical compatibility and economic suitability of Leasecraft for the performance of one or more NASA missions (not limited to the attached payload mentioned in the JEA) beginning with calendar year 1987. 10/1/83
- B. NASA will establish a pricing policy which will apply to the retrieval and return of spacecraft, such as Leasecraft, or payloads therefrom. NASA will work toward establishing this policy by the date indicated and will provide Fairchild periodic status reports. 1/1/84
- C. NASA and Fairchild will seek to negotiate arrangements for short leadtime scheduling and/or manifesting of small payloads and/or on-orbit operations. 6/1/84
- D. NASA will consider the use of Fairchild employees as payload specialists on Leasecraft flights to assist in the operation and servicing of Leasecraft equipment, under terms and conditions to be established in subsequent launch services agreements. 1/1/84
- E. NASA will work with Fairchild for the operational flights of Leasecraft by providing STS launch and TDRSS communication services consistent with charge policies, and use its best efforts to meet scheduling requirements of Leasecraft and reduce overall transportation costs.
- F. NASA will continue to notify Fairchild of any changes to STS pricing policies in advance of the effectivity of the changes.

Fairchild Industries, Inc.

National Aeronautics and  
Space Administration

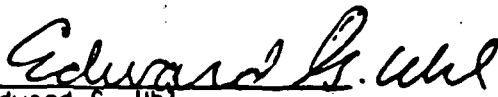
  
Edward G. Uhl  
Chairman and Chief Executive  
Officer

  
James M. Beggs  
Administrator

Date: August 23 1983

Date: August 23 1983

AGREEMENT BETWEEN THE  
NATIONAL AERONAUTICS AND SPACE ADMINISTRATION  
AND  
FAIRCHILD INDUSTRIES, INCORPORATED  
FOR A JOINT ENDEAVOR CONCERNING THE  
RESEARCH AND DEVELOPMENT OF A SMALL  
SPACE PLATFORM FOR COMMERCIAL OPERATIONS

Fairchild Industries, Inc.

National Aeronautics and  
Space Administration

Approved by:

Approved by:

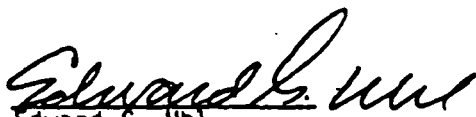
  
Edward G. Uhl  
Chairman and Chief Executive  
Officer

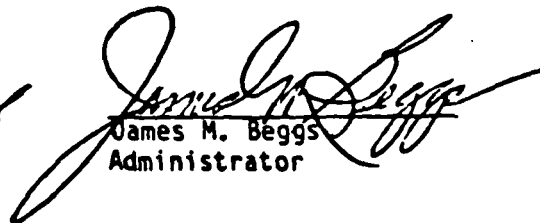
  
James M. Beggs  
Administrator

Date: August 23 1983

Date: August 23 1983

TABLE OF CONTENTS

	<u>Page</u>
PREAMBLE.....	1
ARTICLE I APPROACH.....	3
II FAIRCHILD RESPONSIBILITIES.....	6
III NASA RESPONSIBILITIES.....	9
IV RELEASABLE INFORMATION.....	13
V SPACE SYSTEM EXCLUSIVITY.....	14
VI TERM OF AGREEMENT.....	15
VII TERMINATION.....	16
VIII CONSIDERATION AND RIGHTS.....	18
IX PROGRAM MANAGEMENT AND CONTROL.....	20
X SAFETY AND INTERFACE REQUIREMENTS.....	23
XI RESOURCES AND AVAILABILITY OF APPROPRIATED FUNDS.....	24
- XII DATA RIGHTS.....	25
XIII RECORDS AND ASSOCIATED DATA.....	28
- XIV PROPERTY RIGHTS IN INVENTIONS.....	29
XV ASSIGNMENT AND SUBCONTRACT.....	31
XVI SERVICES CONSISTENT WITH UNITED STATES OBLIGATIONS, LAWS AND PUBLISHED POLICY.....	33
- XVII AUTHORIZATION AND CONSENT AND PATENT INDEMNITY.....	34
XVIII MUTUAL OBSERVATION OF THE RULES.....	35
XIX UNITED STATES GOVERNMENT OFFICIALS NOT TO BENEFIT.....	36
XX RIGHTS OF FAIRCHILD TO DELAY, SUSPEND, POSTPONE OR ACCELERATE A LAUNCH OR PLACE A HOLD ON PRELAUNCH ACTIVITIES.....	37
XXI RIGHTS OF FAIRCHILD TO DEFER OR CANCEL A PAYLOAD OPERATION.....	38
XXII RIGHTS OF NASA TO DELAY AND TO SUSPEND OR POSTPONE AN AGREED UPON LAUNCH.....	39
XXIII RIGHTS OF NASA TO DEFER OR CANCEL PAYLOAD OPERATIONS OR JETTISON A PAYLOAD.....	41
XXIV ALLOCATION OF CERTAIN RISKS.....	42
XXV REVISIONS.....	52
XXVI APPLICABLE LAW.....	53
XXVII DISPUTES.....	54
XXVIII NOTICES.....	55
APPENDIX A.....	56

AGREEMENT BETWEEN THE  
NATIONAL AERONAUTICS AND SPACE ADMINISTRATION  
AND  
FAIRCHILD INDUSTRIES, INCORPORATED,  
FOR A JOINT ENDEAVOR CONCERNING THE  
RESEARCH AND DEVELOPMENT OF A SMALL SPACE PLATFORM  
FOR COMMERCIAL OPERATIONS

PREAMBLE

The National Aeronautics and Space Act of 1958 declares that the aeronautical and space activities of the United States shall be conducted so as to contribute to the preservation of the role of the United States as a leader in aeronautical and space science technologies and their application to the conduct of peaceful activities within and outside the atmosphere. The furtherance of these activities may be substantially enhanced by the early availability of a shuttle-launched and supported mobile, unmanned space platform furnishing the necessary utilities (volume, power, stabilization and communication) for these activities. The Administration and NASA are committed to a reliance on the private sector for the supply of needed commercial products and services whenever available. NASA is, therefore, interested in a commercial firm willing to use their own resources to design, develop, and provide such a platform to users through lease or purchase.

Fairchild Industries believes that there are an increasing number of companies moving toward the use of space and space technology for the profitable production of goods and services. Fairchild wishes to create a commercial entity to lease to government and commercial users a variety of space systems, spacecraft, and space platforms that are launched, serviced and retrieved by the Shuttle. Such a commercial entity could also supply a variety of technical and administrative services, such as the integration of the users hardware with the spacecraft or platform, integration of such a spacecraft or platform with the Shuttle, provision of the necessary documentation and technical support to the user and to NASA for the launch,

operational services, and retrieval of the users products and/or hardware. Fairchild recognizes that it will incur substantial expenses to create such an entity and its shuttle-serviceable hardware, and that these operations may not return profit for a number of years. Fairchild believes that the possible returns from the already planned government and commercial space activities, together with the coming industrialization of space, justify much of that risk. Fairchild believes that its experience with the shuttle-compatible Multimission Modular Spacecraft (MMS) places it in a unique position to assure the technical success of such an enterprise, and to succeed in this aspect of the commercialization of space.

Accordingly, this agreement is made and entered into this 23rd day of August 1983, by and between Fairchild Industries which is a corporation organized and existing under the laws of the State of Maryland, whose principal offices are at Germantown, Maryland, and the United States of America, represented by the National Aeronautics and Space Administration. It delineates the joint endeavor that the parties will undertake and sets forth the terms and conditions therefore. Now, therefore, it is agreed as follows:



## ARTICLE I - APPROACH

A. The Fairchild Leasecraft system is a shuttle-tended, mobile, unmanned space platform supported by ground-based systems and services. The space segment will be spacecraft providing a platform in low earth orbit for scientific, commercial, and government users on a leased or service-contract basis. (While not the intended approach, Leasecraft will be made available for purchase to customers who can be served best in that way.) The user's payload may consist of scientific instruments, material processing equipment or remote sensors carried on a user-supplied or Fairchild-provided payload support structure. Secondary payloads, e.g., instruments, electronics, or other equipment of limited volume and power dissipation, can also be accommodated. Secondary payloads may be mounted in standard MMS module boxes or by other means. The payload will be carried to a rendezvous orbit by the Space Transportation System (STS). The Leasecraft and payloads are subsequently mated on orbit. The spacecraft operate in orbits that are accessible from nominal Shuttle orbits. The configuration can support experimental, pre-operational, and operational programs.

The operational system will consist of one or more spacecraft, spare MMS modules and components, a Ground Support System, a Flight Support System, on-orbit servicing equipment, an Operations Control Center, and associated software and services. The Fairchild Leasecraft system will be responsible for providing to NASA the information to mate the payloads to Leasecraft (typically on-orbit), orbital operations, data and/or product retrieval, and payload demating and return to Shuttle orbiter cargo bay. Leasecraft will also provide payload integration and test services as a user option. Additional technical description is provided in Appendix A.

B. In this joint endeavor, NASA and Fairchild each will be responsible for specific portions of the total venture wherein each party separately and independently provides the resources required to accomplish its portion of the endeavor.

C. This Joint Endeavor will proceed in two sequential phases. The phases are generally defined as follows:

1. Phase 1 - Feasibility Studies and Preliminary Design

Phase 1 will begin with the signing of this document. By that time, NASA and Fairchild will each have designated a Joint Endeavor Manager (JEM) to carry out the terms of this JEA.

Phase 1 consists primarily of a research and engineering effort to establish requirements and to initiate the preliminary design of Leasecraft. In addition, market surveys of potential users and economic analyses will be made. Preliminary schedules for the program will be developed as well as overall flight planning, including the identification of STS, tracking, data acquisition, mission control and other data operations services required for flights. During this phase, a decision will be made as to the payload(s) for the test flights and agreements will be signed with the user(s). Completion of Phase I and entry into Phase II will be determined jointly by the Joint Endeavor Managers.

2. Phase 2 - Program Development and Flight Tests

This phase includes the research, design, development, and manufacture of the test vehicle for the Leasecraft system and the provision of the flight and ground hardware along with its associated software for the test flights. It is expected that the first launch will be scheduled for the second quarter of calendar year 1987, followed by a revisit service flight approximately six months later. Notwithstanding any other provision of the Agreement, the Fairchild payload (which includes the Leasecraft, Leasecraft payloads and all other property to be flown aboard the Shuttle for Leasecraft) will not exceed 360 inches along the keel of the Shuttle and will not exceed 35,000 pounds for the first launch and will not exceed 360 inches along the keel of the Shuttle and will not exceed 32,500 pounds for the service flight. Fairchild shall be eligible for Standard Shuttle Services, and such

optional services as mutually agreed to and documented in the PMP required to accomplish the missions objectives including power, cooling and crew operation consistent with the load factor for the Fairchild payload, unless the parties otherwise agree. Also during this phase, planning will be accomplished with NASA and users for the operational period. Flight schedules, launch services, and associated rates will be established with NASA through Launch Services Agreements for the operational flights to follow.

- D. The parties to this Agreement are cooperative participants. (Neither party is regarded to be the leader or superior party with respect to the joint activities contemplated by this Agreement.) Fairchild and NASA will each appoint and so designate a Joint Endeavor Manager who shall have responsibility for assuring that the respective parties' responsibilities are satisfied. In this capacity, the NASA JEM and the Fairchild JEM will serve as the sole interface for management and control of commitments regarding this joint endeavor. The parties recognize that actions and decisions by one party can significantly affect the other's work under this endeavor, and therefore they agree to maintain frequent communications with regard to progress, status of approvals, potential problems, and schedule changes. It is also understood that the respective JEMs may authorize the establishment of direct technical channels for implementation of this Agreement, as well as channels for data and information flow between parties. The parties further recognize that, in the course of the programmatic and technical exchanges and reviews that will occur under this endeavor, representatives from the respective organizations may provide advice and comments on the approach and merits of the work being conducted by the other. Such advice and comments are not to be construed by either party as direction or control of the work being performed. Further, a party's use of such advice and comments is at its own discretion and risk.

## ARTICLE II - FAIRCHILD RESPONSIBILITIES

- A. With the goal of substantially supporting the commercialization of space, Fairchild will use its best efforts to design and develop a mobile, unmanned space platform and associated facilities and services for use by a wide range of commercial and government users of space.

Consistent with this goal and in accordance with the overall approach described in ARTICLE I, Fairchild shall, at no cost to NASA:

### 1. Phase I

- a. Develop the requirements for and initiate preliminary design of a mobile, unmanned space platform, including ground and flight support equipment and software, based on MMS technology, which will have the capability of supporting a variety of commercial, scientific and experimental users.
- b. Conduct market surveys to identify potential commercial and government users of the Fairchild Leasercraft system.
- c. Develop preliminary pricing policies, criteria, prices, and business procedures for lease of Fairchild's Leasercraft, facilities, and services by users.
- d. Define the requirements and develop preliminary plans to successfully demonstrate Leasercraft operations and payload changeout to be conducted with the STS during Phase II.
- e. Identify technical data and services required by NASA to conduct flights of Leasercraft.
- f. Develop jointly with NASA a Program Management Plan (PMP) in accordance with ARTICLE IX.

- g. Provide NASA with information from which NASA can determine the suitability of Leasercraft for NASA missions.

## 2. Phase II

- a. Design, develop, test and verify the compatibility of Leasercraft, together with its payload, with the STS, certify the flight readiness and provide the flight hardware and related ground and flight support equipment and software necessary for the test flights. As part of this effort, Fairchild will conduct the necessary design and flight readiness reviews, with NASA participation as defined in the PMP, to ensure compatibility with the existing STS configuration and to meet safety requirements.
- b. Develop detailed plans with NASA for the initial test flight by the second quarter of calendar year 1987 and the re-visit flight approximately six months thereafter.
- c. Support NASA's integration and launch operations of the Leasercraft with its payload into the STS and provide any unique ground and flight support equipment as specified in the PMP.
- d. Provide personnel and Leasercraft-unique equipment and related software for a NASA provided operations control center for space operations during the test flights.
- e. Conduct the free-flight operations of the Leasercraft and its payload during the test flights, except that the conduct of the Leasercraft operations during the service flight shall be agreed upon in the PMP.
- f. Establish agreements with users and determine pricing arrangements, launch schedules, and other Fairchild services required for the follow-on operational flights.

- g. Jointly with NASA, share Fairchild MMS-compatible test equipment, flight support and ground support equipment and software, to be specified in the PMP, as available on a non-interference basis with Fairchild's activities and only during the term of this agreement.
- h. If NASA exercises its option to provide an attached payload, as described in Article III, paragraph 1.h, mount such attached payload onto the initial Leasecraft flight article and conduct the necessary pre-flight functional testing, with NASA support.
- i. At NASA's option, provide services to NASA, as defined in Article III.2.b, on the service flight covered by this Agreement. If NASA does not retrieve its attached payload(s) on the service flight, or if NASA changes out its attached payload(s) on the service flight, NASA will not be charged for the use of Leasecraft services for the term of this Agreement for such attached payloads. If the NASA attached payload(s) is not retrieved during the term of this Agreement, the parties shall seek to negotiate a separate appropriate agreement for the use of Leasecraft services after the term of this Agreement.

### ARTICLE III - NASA RESPONSIBILITIES

With the goal of making a significant contribution to technological innovation and U.S. leadership in space by making facilities and services available to users on a lease basis, NASA will use its best efforts, on a non-interference basis with NASA activities, to provide the technical assistance, flight time on the STS, and available general purpose equipment and/or facilities needed to support the research and development effort to permit the commercial availability of the Leasecraft System.

Consistent with the purpose stated herein, and in consideration for the contribution that Fairchild agrees to make to develop and produce the Leasecraft system, NASA shall, at no cost to Fairchild:

#### 1. Phase I

- a. Make available to Fairchild releasable applicable designs, software and procedures from the NASA/GSFC Flight Projects Directorate and other NASA sources for possible use in designing and developing the Leasecraft system, this availability to continue through Phase II.
- b. Conduct the necessary planning, scheduling, manifesting and budgeting to provide STS flights, related services, and available general purpose equipment to successfully complete the Leasecraft test and service demonstration flights in Phase II.
- c. Furnish to Fairchild design criteria related to safety of flight, as well as interface, integration and test, and checkout requirements as applicable to Leasecraft and its payloads, this effort to continue through Phase II.
- d. Develop jointly with Fairchild a Program Management Plan (PMP) in accordance with ARTICLE IX.

- e. Provide design review support to Fairchild, as agreed to by NASA, from the NASA/GSFC System Review Office, and consulting support from NASA technical experts, this support to continue through Phase II.
- f. Permit Fairchild access, on a non-interference basis with NASA activities, to NASA centers under "contractor" designation to meet its responsibilities under this agreement, this privilege to continue through Phase II.
- g. Jointly with Fairchild, identify any requirements for training of NASA personnel that will use Fairchild equipment, facilities or services, this effort to continue through Phase II.
- h. At NASA's option, NASA will designate an attached payload, generally the size of an MMS Box, or operational test for each test flight of the Leasecraft demonstration. NASA may designate additional payload(s) or operational test(s) if Fairchild agrees. The operation of the payload or operational test will be, with Fairchild's concurrence, compatible with test flight objectives. Such attached payloads will be provided to Fairchild fully assembled, self-contained, flight-ready, and compatible with Leasecraft interfaces.
- i. With respect to NASA attached payload(s), at NASA's option, NASA will select the services, as defined in Article III.2.b., that will be performed on the service flight covered by this Agreement.

## 2. Phase II

- a. To begin space testing of the Leasecraft system, provide pre-launch and launch services, including optional services normally provided to STS payloads, for an STS payload consisting of a Leasecraft and a Leasecraft payload, both to be designated by Fairchild, the latter with NASA concurrence. Fairchild shall provide NASA with written notice of its Leasecraft payload designation for this space test at least 18 months prior to the



scheduled launch date for the STS payload described. If no NASA objection to Fairchild's designation of such Leasecraft payload is received by Fairchild within 45 days of its written notification to NASA of such designation, then such designation will be approved.

- b. In order to complete testing of the Leasecraft system, within approximately six months of the initial launch, provide a service flight and perform on-orbit servicing of a Leasecraft and its payload(s), including appropriate pre-launch, launch and landing support. Servicing means payload changeout or resupply, or the return of a Leasecraft and/or its payload to earth or other servicing as agreed to by the parties. Following the successful completion of this test program, NASA will verify the extent to which the operation of the Leasecraft system has met the joint Fairchild-NASA test objectives and is compatible with the Space Transportation System.
- c. Provide support of the Multi-Satellite Operations Control Center and Missions Operations Room at Goddard Space Flight Center that is comparable to that provided to a NASA mission, for the flights covered under this agreement, and as agreed upon in the PMP. Fairchild to make best efforts to minimize NASA's out-of-pocket expenses for this item.
- d. Provide an agreed upon level of service of the Tracking and Data Relay Satellite System in accordance with NASA Management Instruction as published in The Federal Register under Title 14, Chapter V, Part 1215 48 FR 9845-9849, March 9, 1983, with designation as a NASA payload/spacecraft and as agreed upon in the PMP.
- e. Make available, on a non-interference basis with NASA activities, NASA test facilities, as may be agreed upon in the PMP. ]

- f. Periodically furnish to Fairchild, upon request, applicable data on relevant NASA programs that might use Fairchild's facilities and services for the operational flights.
- g. Consider the use of Leasecraft for NASA missions compatible with its capability and, as they are identified by either party, opportunities for joint development of new or expanded Leasecraft system capabilities that would be mutually beneficial.
- h. Jointly with Fairchild, share NASA MMS-compatible test equipment, flight support and ground support equipment and software, to be specified in the PMP, as available on a non-interference basis with NASA's activities and only during the term of this Agreement.
- i. Refer all inquiries regarding the use of Leasecraft to Fairchild.
- j. If NASA exercises its options to provide an attached payload(s), as described in Article III, paragraph 1.h., or payload change out or re-supply as described in Article III, paragraph 1.i. deliver such payload to Fairchild in fully assembled, flight ready and operational form together with all necessary ground and flight support equipment, test and operational software, on a schedule to be determined in the PMP.

#### ARTICLE IV - RELEASABLE INFORMATION

It is recognized that from time to time the parties may desire to release to the public and appropriate government organizations information about the endeavor. Release of public information regarding the endeavor may be made by NASA and Fairchild as to their participation and activities as desired and insofar as the participation and activities of the other is involved, after suitable consultation. In the release of such information, the parties agree to exercise reasonable discretion, considering the nature of this endeavor and the need to keep the public informed. In addition, it is agreed that the following listed technical information, to be furnished by Fairchild to NASA may be released to the public without consultation:

- A. The contents of this agreement.
- B. Overall system descriptions, including external dimensions, of Fairchild systems, but excluding design details.
- C. General information on potential applications of the Fairchild Leasecraft Program.
- D. Data as may be needed for STS interface verification, payload integration and checkout.
- E. General performance data of the Leasecraft, and its payloads, and other devices flown on board Leasecraft, excluding detail design information and trade secrets.

ARTICLE V - SPACE SYSTEM EXCLUSIVITY

- A. During the period from the signing of this Agreement through December 31, 1986, NASA will not use appropriated funds to develop in-house or procure a platform similar to Fairchild's Leasecraft Platform nor enter into an international cooperative agreement to develop a platform similar to Fairchild's Leasecraft Platform.
  
- B. For purposes of this Article, a similar space platform would be an unmanned spacecraft, STS-deployed and left in orbit, whose payloads would be changed or serviced in space, which would be replenished and repaired as necessary by subsequent STS visits and that provides maximum continuous power to a payload of no more than 12.5 kw. This does not include specific designs for a single purpose or mission, one of a kind spacecraft, where the spacecraft components are a tightly integrated part of the space system. Rather, it is directed to restricting the development, at Government expense, of self-sustaining free flying platforms that would compete with Fairchild's Leasecraft.
  
- C. Nothing in this Agreement shall preclude NASA from selling launch and associated services or other services to an organization on a reimbursable basis in accordance with NASA charge policies.

ARTICLE VI - TERM OF AGREEMENT

This Agreement shall be in force until six months after the successful completion of the flight test program and data evaluation, culminating in NASA verification that the test flight objectives have been met, or December 31, 1989, whichever comes first. This term is extendable by mutual written agreement of signatories of this Agreement.

## ARTICLE VII - TERMINATION

### A. Termination during Phase I

At the end of Phase I either party may elect to terminate this Agreement. It is expected that any such decision to terminate would be made following the completion of a scheduled review specified in Article IX of this Agreement and would be based on the data, information and assessments developed for or resulting from that review. In the event of such termination, the parties agree to negotiate in good faith the disposition of data, information, patents and other results of work accomplished or in progress, arising from or performed under this Agreement.

Neither party shall be entitled to any compensation due to such termination and neither party will be required to transfer any data, information, patents or other results of work accomplished or in progress other than as agreed to in such negotiations.

### B. Termination during Phase II

1. Fairchild may elect to terminate unilaterally this Agreement for any reason by giving NASA written notice not less than 90 days prior to the desired termination date. In the event of such termination, NASA shall be entitled to purchase and take title to all flight hardware and related software and support equipment completed or in process at the cost incurred by Fairchild. NASA shall have the license rights in and to all patents and data as set forth in ARTICLES XII and XIV.

2. NASA shall have the right to terminate unilaterally this Agreement (i) upon declaration of war by the United States, (ii) upon declaration of a national emergency by the Congress of the United States, (iii) upon the failure of the Congress of the United States to provide NASA adequate appropriations, as indicated in Article XI of this Agreement, or (iv) upon a determination in writing that NASA is required to terminate the Launch and Associated Services for Reasons Beyond NASA's Control. If practical,

prior to terminating NASA shall consult with Fairchild for the purpose of reviewing the available evidence which requires NASA to terminate. NASA will consider Postponing a Payload launch before considering terminating its commitment, in whole or in part, under the authority in this Subparagraph B.2. For purpose of this Subparagraph B.2., "Reasons Beyond NASA's Control" include, but are not limited to, acts of God or of the public enemy; acts of the United States Government other than NASA, in either its sovereign or contractual capacity; fires, floods; epidemics; quarantine restrictions; strikes; freight embargoes or unusually severe weather which make impractical NASA's or its contractor's or subcontractor's performance of Launch and Associated Services. NASA agrees that it will not terminate this Agreement for "Reasons Beyond NASA's Control" unless there is a resulting cessation of Shuttle launches for commercial purposes for a substantial period of time.

ARTICLE VIII - CONSIDERATION AND RIGHTS

- A. In discharging its responsibilities per ARTICLE III, NASA's primary interests are in stimulating and accelerating the transition from research and development to commercial availability of necessary facilities, utilities, and services at a reasonable cost to potential users of space, thereby increasing taxable revenue from space activities. In discharging its responsibilities per ARTICLE II, Fairchild is concerned with making a fair return on its research and development effort considering the high and long-term technological and economic risks it has undertaken by execution of this Joint Endeavor Agreement. Fairchild contemplates making significant expenditures for several years under circumstances where the outcome of the endeavor is highly speculative due to technical and market uncertainties. During the earlier years, when the risk is highest, Fairchild will expend substantially more in its part of the endeavor than NASA. Fairchild will also make available for use under this endeavor valuable intellectual property in the form of proprietary data and patent rights, as well as skills related to space platforms and MMS technology.
- B. It is the intent of both parties that this joint endeavor will result in commercial sales. Fairchild will exert its best efforts to make results of this joint endeavor available to the United States public on reasonable terms and conditions. The reasonableness of the terms and conditions shall include a fair return to Fairchild and associated third parties. Parallel to the development and demonstration of commercially available facilities, utilities, and services to support the initial test flights of Leasecraft, Fairchild, at its option, will make such equipment and services available to others via lease or purchase. Subject to the rights reserved to the Government under ARTICLES XII or XIV of this Agreement, Fairchild shall exclusively have the right to enter into agreements with others for the provision of Leasecraft hardware, software and services, without concurrence of NASA except as otherwise specified herein. Operational flights with commercial users will be on a fully reimbursable basis to NASA in accordance with STS pricing policies and specific launch service agreements executed for that purpose.



C. In consideration for the risks undertaken, effort expended, and cost incurred by the parties, the rights under this agreement are apportioned in accordance with ARTICLES V, XII and XIV, respectively entitled "Space System Exclusivity," "Data Rights," and "Property Rights in Inventions."

ARTICLE IX - PROGRAM MANAGEMENT AND CONTROL

A. Management Structure

The parties to this agreement shall be separately responsible for establishing the necessary management and work elements structure within their respective organizations, which shall have both the scope and capacity required to discharge their respective responsibilities as set forth in ARTICLE II and III hereof and in accordance with the Program Management Plan (PMP).

B. Management and Control Documents

This Agreement provides for two levels of management control as follows:

1. Level I

Level I encompasses the basic understanding between the two organizations and is documented by this Agreement. This Agreement is the controlling document and any other agreements, understandings and documentation relating to it are deemed subordinate.

2. Level II

- a. Level II controls the implementing and operating interface between the two organizations and includes measurable performance objectives and milestones for progress assessments and decisions. The Program Management Plan (PMP) is the basic Level II document and will be approved by the respective JEMs. The parties understand and recognize that the STS services (Shuttle Standard and Optional) to be furnished by NASA shall be specifically defined for each Phase in the PMP and limited to: (i) normal, relevant services provided by NASA to Shuttle payloads, (ii) STS general purpose equipment and available facilities, (iii) common operational research equipment as available and (iv) such support equipment and software to be agreed to under Article III. 2.h.

b. A Program Management Plan will be mutually developed by the two parties and shall serve as the Level II technical and programmatic baseline for this Endeavor. The PMP shall detail the plans and requirements needed for the parties to fulfill their respective responsibilities under this Agreement, including measurable objectives and milestones, and shall be the baseline against which progress will be assessed at the periodic reviews. It shall include, but not be limited to, the following:

- (1) Program objectives and approach
- (2) Technical performance requirements
- (3) Design and development plans, including plans for verification of safety and interface requirements developed in accordance with ARTICLE X
- (4) Delineation of the hardware, software, facilities, data, and services to be furnished by the respective parties, including definition of launch and associated services
- (5) Delineation of services for tracking, data acquisition, mission control and other data operations.
- (6) Schedules

C. Reviews and Meetings

1. The parties will consult periodically, as determined to be appropriate by the JEMs, to exchange technical, programmatic and other information needed to assess progress of this endeavor and make timely decisions. The JEMs shall call upon other individuals from their respective organizations, including contractors and consultants, to participate as necessary and appropriate in such consultations.
2. The parties shall meet periodically, as determined by the respective JEMs, for a formal review of planning, progress and problems. At the initial review, each party shall present its respective portion of the PMP and supporting documentation for discussion, possible revision and

subsequent agreement. The reviews shall include such items as accomplishments, plans and problems related to technical progress, schedule considerations, manpower allocations, risk assessments and such other items as may be required to facilitate a mutual understanding of the status of the Leasecraft program and to make timely decisions.

## ARTICLE X - SAFETY AND INTERFACE REQUIREMENTS

### A. Safety

The Leasecraft system design, development and operations shall comply with the NASA safety requirements in NHB 1700.7, Safety Policy and Requirements for Payloads Using the Space Transportation System (STS).

### B. Interface Requirements

As early in Phase I as practical, the parties shall cooperatively develop documentation to assure the electrical, structural, functional and operational compatibility of the Fairchild equipment (hardware and software) with NASA's ground and flight equipment and procedures. Interface documentation will be approved by the JEMs on behalf of the parties. During this Agreement NASA may update interface specifications and other design and operations restraints in providing for the compatibility of the payload with the Shuttle. NASA will use its best efforts to find a solution to interface problems that minimize the resulting efforts and costs.

### C. Reliability

Fairchild and NASA agree to apply their best efforts to assure that all equipment, hardware and software will function reliably for its intended purposes and use, provided, however, that Fairchild and NASA respectively disclaim any warranties or representations to the other with respect to such equipment, hardware and software.

ARTICLE XI - RESOURCES AND AVAILABILITY OF APPROPRIATED FUNDS

- A. NASA, subject to the limitations set forth in Paragraph B below, and Fairchild shall provide funding and all other resources required to fulfill their respective responsibilities set forth in this agreement. There will be no exchange of funds between Fairchild and NASA under this agreement.
  
- B. NASA's ability to perform its obligations under this Agreement is subject to the availability of appropriated funds. If adequate appropriations are not forthcoming, this shall be construed as a unilateral termination by NASA under Paragraph B of ARTICLE VII of this Agreement. However, NASA shall use its best efforts to obtain needed funding.

## ARTICLE XII - DATA RIGHTS

- A. Data means recorded information, such as but not limited to writings, drawings, recordings and pictorial representations, regardless of form or the media on which it may be recorded.
  
- B. All data furnished to NASA included in the list contained in ARTICLE IV of this Agreement shall be furnished with unlimited rights (the right to use, reproduce, disclose in any manner and for any purpose whatsoever), and without restrictive legend. Recognizing that the requirements for, and the need for protection of, data may change during different phases of this Agreement, NASA and Fairchild may from time to time, upon mutual agreement, change the listing of data to be furnished pursuant to ARTICLE IV.
  
- C. Other than as provided in Paragraph B above, NASA will use its best effort to assure that any data required to be furnished, or in fact furnished under this Agreement will be used, reproduced, and disclosed by the Government only for the purpose of carrying out its responsibilities under this agreement. In the event the data qualifies as a trade secret and the originator of such data desires to maintain trade secret rights therein, such data shall be marked with the following (and no other) notice and the Government will thereafter treat the data in accordance with the Notice:

## NOTICE

This data is a trade secret of \_\_\_\_\_ and is submitted in confidence to NASA under Joint Endeavor Agreement, No. \_\_\_\_\_ dated \_\_\_\_\_, 1983. NASA agrees that the data will not, without permission of Fairchild be duplicated, used or disclosed by NASA or its contractors for any purpose other than as necessary to carry out NASA's obligations under this Agreement. If required by such contractors, the data will only be furnished after the contractors have agreed with NASA in writing to protect the data from unauthorized use, duplication and disclosure. This notice shall be marked on any reproduction of the data, in whole or part.

- D. Notwithstanding any other provisions of this Agreement, data owned by Leasecraft customers need not be furnished to NASA except as required by NASA for safety, integration and compatability with other payloads and the Shuttle and as may be required by Articles IV, XV and XVI of this Agreement.
- E. Fairchild or any party in privity therewith agrees to furnish data first produced in carrying out Fairchild's responsibilities under Article II of this Agreement to responsible parties designated by NASA or to NASA and Fairchild further agrees that NASA itself may furnish such data to responsible parties if the NASA Administrator or his/her designee determines such action is necessary (i) because Fairchild has not taken, or is not expected to take within a reasonable time, effective steps to achieve commercial utilization of the results demonstrated or to be demonstrated under this Agreement, or (ii) to enable the practice of any license rights to patents or inventions acquired by NASA pursuant to ARTICLE XIV of this Agreement, or (iii) in the event of a unilateral termination in accordance with ARTICLE VII, Paragraph B.1. Any of the above determinations by the NASA Administrator or his/her designee shall be in acordance with the provisions of Paragraph C of ARTICLE XIV of this Agreement. Data



(other than unlimited rights data under ARTICLE XII) when furnished as agreed above will be royalty free, under protective conditions, for use by NASA, or responsible parties acting on NASA's behalf, to complete the objectives of the Agreement if such is necessary, and for the practice of any license rights to patents and inventions under ARTICLE XIV. All other use of the data will be under terms and conditions reasonable under the circumstances.

### ARTICLE XIII - RECORDS AND ASSOCIATED DATA

Fairchild and NASA agree to maintain technical records, documents and other associated data pertaining to the design, development, manufacture, test integration and operation of Fairchild hardware and software. These records and documents shall be of sufficient detail and completeness that, in the event of determinations made under ARTICLE XII or ARTICLE XIV or termination by one party, the other can continue the program if it so desires. Upon request, the NASA JEM or a mutually agreed designee shall have access to Fairchild generated records at all reasonable times during regular business hours. All data reviewed under this Article which qualifies as a trade secret shall be treated as trade secrets in accordance with ARTICLE XII, Paragraph C entitled "DATA RIGHTS" The records, documents and other associated data identified above shall be preserved for a period of at least seven years from the date of termination of this Joint Endeavor Agreement.

ARTICLE XIV - PROPERTY RIGHTS IN INVENTIONS

- A. Except for the rights reserved by NASA in Paragraph B below, and those rights provided pursuant to ARTICLE VII entitled "Terminations," Fairchild and any party in privity therewith shall retain all right, title and interest to any invention conceived or first reduced to practice in carrying out its responsibilities under this agreement as described in ARTICLE II of this agreement.
- B. With respect to any invention subject to Paragraph A above, the following will apply:
1. NASA shall have a contingent royalty-free license to practice or have practiced such inventions by or on behalf of the Government for any Governmental purpose. The contingent royalty-free license is a nonexclusive paid-up license to all inventions contained in Paragraph A above, and all data and patents necessary to practice or have practiced such inventions, which data will be furnished to NASA, and will become effective if the NASA Administrator or his/her designee determines such action is necessary: (i) because Fairchild or any party in privity therewith has not taken, or is not expected to take within a reasonable time, effective steps to achieve commercial utilization of the invention; or (ii) in the event of a unilateral termination in accordance with ARTICLE VII, Paragraph B.1.
  2. If a determination is made by the NASA Administrator or his/her designee that action is necessary as a result of (i) or (ii) in Paragraph B.1. above, NASA has the right to require the granting of a license to responsible parties, upon terms and conditions reasonable under the circumstances, or to so grant such a license itself, if in the judgement of the NASA Administrator or his/her designee that Fairchild or its parties in privity have not effectively taken steps or have been unsuccessful in licensing to satisfy the requirements of (i) and (ii) above.
- C. Prior to the making of a determination by the NASA Administrator or

his/her designee under Paragraph B above, NASA shall give Fairchild sixty days written notice of intention to make such determination and provide findings in support thereof and shall afford Fairchild an opportunity to be heard and offer evidence in support of its position. Any determination will be subject to ARTICLE XXVII, "DISPUTES."

- D. Fairchild shall, at the request of NASA, provide NASA with a brief description of any invention subject to Paragraph A above, and of any action taken to obtain patent protection thereon, and of the final disposition of such action. Any brief description so provided shall be subject to protection from disclosure under the provision of Paragraph C of ARTICLE XII, "DATA RIGHTS" until a patent is issued thereon or the patent application is otherwise made available to the public.

ARTICLE XV - ASSIGNMENT AND SUBCONTRACT

- A. This Agreement shall not be assignable by Fairchild without the prior written consent of NASA, except that it may be assigned without such consent to a United States Person or Entity which is (i) a successor of Fairchild, (ii) a firm or corporation acquiring all or substantially all of the business and assets of Fairchild relating to the Leasercraft System, (iii) a wholly-owned subsidiary corporation of Fairchild, or (iv) a partnership affiliated with Fairchild or a wholly-owned subsidiary of Fairchild formed for the purpose of financing Fairchild's responsibilities and obligations to be performed under this Agreement. No assignment of this Agreement shall be valid until and unless all the terms and conditions of this Agreement have been assumed by the assignee and NASA consents in writing that the assignee is technically qualified and financially capable of fulfilling the Agreement, which consent will not be unreasonably withheld. When duly assigned in accordance with the foregoing, this Agreement shall be binding upon and shall inure to the benefit of the assignee. In the event of assignment as specified in (iii) or (iv), Fairchild will also, in addition to the assignee, remain obligated to NASA under all the terms and conditions of this Agreement, and the assignment will set forth the party or parties as mutually agreed upon between Fairchild, the assignee and NASA with whom NASA is to interface under the Agreement with regard to technical, financial, and scheduled matters.
- B. Fairchild may subcontract parts of its work to be performed under this Agreement without obtaining the consent of NASA.
- C. Fairchild may provide services or lease the Leasercraft to users subject to the following limitations:
- (i) Fairchild shall notify NASA in writing of the identity of its users whom Fairchild believes may not be a United States Person or Entity and who are to provide Leasercraft payloads to Fairchild to be flown on board the Shuttle; and within thirty days following receipt of notice from Fairchild, NASA shall have the right to disapprove in writing to Fairchild

the flight of the Leasecraft payload on board the Shuttle for any user who is not a United States Person or Entity.

(ii) With respect to each user Fairchild shall provide the identity of the user and a description of the payload and its general performance for purposes of receiving NASA's concurrence referenced to in Article III.2.a.

ARTICLE XVI - SERVICES CONSISTENT WITH UNITED STATES' OBLIGATIONS, LAW AND  
PUBLISHED POLICY

NASA shall furnish launch and associated services under this Agreement to the extent consistent with the United States' obligations (including any intergovernmental memorandum of understanding entered into by NASA and the User), United States' Law and United States' published policy.

ARTICLE XVII - AUTHORIZATION AND CONSENT AND PATENT INDEMNITY

NASA hereby gives its authorization and consent to Fairchild and any party in privity therewith for all use and manufacture of any invention or process described in and covered by a patent of the United States in carrying out its responsibilities set forth in ARTICLE II of this Agreement. Fairchild agrees to indemnify the Government for any costs incurred by the Government as a result of the unlicensed use (infringement) of privately owned U.S. patents to the extent that any such costs are attributable to the responsibilities set forth in ARTICLE II of this Agreement.

Such costs shall include, but are not limited to, administrative claims against NASA for infringement of such patents, as well as costs incurred by the Government in the form of a judgment against the U.S. by a court of competent jurisdiction. Fairchild shall be given an opportunity as is afforded by applicable laws, rules, or regulations to participate in the defense of such suits, and no settlement of any such claim or suit will be made without Fairchild's written consent other than as required by final decrees of a court of competent jurisdiction.



ARTICLE XVIII - MUTUAL OBSERVATION OF THE RULES

In the performance of this Agreement, Fairchild and NASA will be required to visit and work at the other's installation/plant facilities, and therefore each party agrees to observe the safety, security and plant operating rules while on the other's property.

ARTICLE XIX - UNITED STATES GOVERNMENT OFFICIALS NOT TO BENEFIT

No member of or delegate to the United States Congress, or resident commissioner, shall be admitted to any share or part of this agreement, or to any benefit that may arise therefrom, but this provision shall not be construed to extend to this agreement if made with a corporation for its general benefit.

ARTICLE XX - RIGHTS OF FAIRCHILD TO DELAY, SUSPEND, POSTPONE OR ACCELERATE A LAUNCH OR PLACE A HOLD ON PRELAUNCH ACTIVITIES

- A. Unless the parties otherwise mutually agree, the rights of Fairchild to delay a launch shall consist of the right to delay liftoff of the Shuttle, exclusive of NASA's right to delay, for a period not in excess of a total of seventy-two hours beyond the time of scheduled liftoff on the previously agreed launch date with NASA's concurrence. NASA's concurrence will not unreasonably be withheld. Fairchild agrees to exercise this right in a reasonable manner with reasonably prompt notification to NASA. This right to delay will be reduced or terminated to the extent that other users on the same Shuttle flight as Fairchild have in the aggregate used part or all of the seventy-two hours. Fairchild shall effect such a delay (i) only after the NASA-specified time for delivery of the payload or any portion thereof to the cargo integration facility, unless NASA otherwise agrees, and (ii) by giving written notification to NASA specifying the circumstances of the request for delay. Fairchild shall have no other right to postpone, suspend or accelerate a launch except as otherwise mutually agreed between the parties.
- B. Fairchild shall have the right, with NASA's concurrence, to interrupt any prelaunch activity involving the payload if Fairchild has reason to believe that continuation of the activity would adversely affect the success of Fairchild's payload mission (hereinafter called "hold"). At the time a hold is placed by Fairchild, or as soon thereafter as practical, the NASA JEM and the Fairchild JEM, or their designees, shall document in writing the circumstances that necessitated the hold and the resulting launch schedule impact of the hold. A hold will result in a delay if the scheduled time of liftoff of the Shuttle is impacted by the hold.

ARTICLE XXI - RIGHTS OF FAIRCHILD TO DEFER OR CANCEL A PAYLOAD OPERATION

Fairchild, in the person of the JEM, shall have the right to defer or cancel all or a portion of the planned payload operations after the liftoff of the shuttle, so long as NASA can safely halt such operations, by notifying the NASA Mission Manager, or his designee, who will in turn notify the NASA Flight Director of the decision to defer or cancel. The payload operations may be rescheduled later in the shuttle flight at the request of Fairchild, if NASA so agrees.

ARTICLE XXII - RIGHTS OF NASA TO DELAY AND TO SUSPEND OR POSTPONE AN AGREED UPON LAUNCH

The rights of NASA to delay and to suspend or postpone a launch shall be exercised by NASA in a reasonable manner and with reasonably prompt notification to Fairchild and shall consist of:

- A. The right to delay a liftoff of the Shuttle, after the NASA specified time for delivery of Fairchild's payload, another payload on the same Shuttle flight as the Fairchild payload, or any portion of the Fairchild payload or other such payloads to the cargo integration facility, exclusive of Fairchild and any other user's right to delay, for a period not in excess of a total of seventy two hours beyond the time of scheduled liftoff on the agreed upon date and the right to further delay liftoff beyond the seventy two hour period, after consulting Fairchild and all other users on the same Shuttle flight. In the event of delays beyond seventy two hours, NASA will consult and cooperate with Fairchild in rescheduling the launch, considering the loss of revenue to Fairchild caused by the launch delay.
- B. The right to suspend or postpone a payload launch, after consulting Fairchild, if the agreed upon date is delayed beyond seventy two hour period defined in ARTICLE XX above as a direct result of one or more requests by Fairchild for such delay.
- C. The right to suspend or postpone a launch of a Fairchild payload if Fairchild fails to meet any significant obligation under this Agreement, including its obligation to provide, on the schedule specified in the PMP, payload hardware and software that are operationally compatible with the STS and related payload checkout and integration functions.
- D. The right to suspend or postpone a launch or on-orbit service of Fairchild's payload if major or untimely modification or rework, as determined by NASA, would be required to the Shuttle hardware, software, or procedures as a result of proposed changes by Fairchild to the interface and/or mission requirements set forth in the PMP. It shall be the responsibility of Fairchild to ascertain from NASA the impact of

requested changes prior to giving written request to NASA for such changes. On a timely basis, upon request of Fairchild, NASA shall consult with Fairchild in evaluating the impact of the proposed changes and provide relevant, readily available information to Fairchild.

- E. The right to suspend or postpone a launch or on-orbit service of Fairchild's payload if NASA determines that it would be necessary because, in NASA's judgement, the safety or probable success of the launch would be affected due to unfavorable weather conditions, equipment malfunctions, delay in the availability of necessary Shuttle services, including the flight crew or payload specialists, or other similar reasons, or for reasons beyond NASA's control. This right to suspend or postpone shall apply also to a launch delay that is directed by the Commander, United States Air Force Eastern Space and Mission Center.
  
- F. The right to suspend or postpone a launch of a Fairchild payload in order to maintain the sequence of Shuttle flights or if NASA is faced with a conflict between the agreed upon launch date of a payload and that desired (e.g., launch window) for another payload. In such a case (i) the payload launch will be dealt with on the same basis as would any other comparable payload launch, (ii) each payload launch shall be treated in terms of its own requirements, including consideration of the financial and other consequences such as suspension or postponement would cause and (iii) NASA shall consult with Fairchild and with all other affected parties in order to arrive at an equitable solution.

ARTICLE XXIII - RIGHTS OF NASA TO DEFER OR CANCEL PAYLOAD

OPERATIONS OR JETTISON A PAYLOAD

- A. NASA shall have the right to defer all or a portion of the planned payload operations if, in NASA's judgement, start or continuation of such payload operations would adversely affect the safety or planned objectives of the Shuttle flight. The payload operations will be rescheduled later in the Shuttle flight following satisfactory resolution of the cause for deferral, as determined by NASA, if NASA can accommodate such a rescheduling. NASA shall reasonably exercise its judgement to defer the planned payload operations based upon the data available at the time such decision is made and will consult with Fairchild to the extent practicable in making such decision. In any event, NASA will immediately advise Fairchild of its decision in this regard.
  
- B. NASA shall have the right to cancel all or a portion of the planned payload operations if, in NASA's judgement, the payload operations would adversely affect the safety or planned objectives of the Shuttle flight or would require an extension in the planned duration of the Shuttle flight. NASA shall reasonably exercise its judgement to cancel the planned payload operations based upon the data available at the time such decision is made and will consult with Fairchild to the extent practicable in making such a decision.
  
- C. NASA shall have the right to jettison a payload after liftoff of the Shuttle if, in NASA's judgement, the payload presents an immediate or unresolvable danger to human life, another payload or the Shuttle flight. Such action shall be taken by NASA only after reasonable effort to place the payload in a safe configuration and, circumstances permitting, only after consultation with Fairchild.

## ARTICLE XXIV - ALLOCATION OF CERTAIN RISKS

### A. General

1. Certain risks of liability, as defined below, arising out of the launch and associated services to be provided by the United States Government and its contractors and subcontractors under this Agreement shall be allocated between Fairchild and the United States Government as set forth in this ARTICLE XXIV. To the extent that a risk of damage, as defined below, is not dealt with expressly in this Agreement, the United States Federal Law shall govern the allocation of such risk between Fairchild and the United States Government.
2. For purposes of this Agreement, the following definitions shall be applicable:
  - a. "Liability" shall include payments made pursuant to United States' treaty, any judgement by a court of competent jurisdiction, administrative and litigation costs, and, after consultation with Fairchild, settlement payments.
  - b. "Damage" shall mean bodily injury to or death of any person, damage to or loss of any property, and loss of revenue or profits or other direct, indirect or consequential damages arising therefrom.

### B. Third Party Liability

1. Fairchild shall obtain, at no cost to NASA, insurance protecting Fairchild and the United States Government from any third party liability for damage arising out of the performance of this Agreement during the risk period (as defined herein).
  - a. The "risk period" for Fairchild begins at the start of the physical attachment by bolt or other device of the Leasecraft or Leasecraft payload to the Orbiter.



- b. The "risk period" for Fairchild after launch of a Leasecraft or Leasecraft payload ends upon the landing of the particular Orbiter without causing damage to third parties or, if a Leasecraft or Leasecraft payload is jettisoned, when the Leasecraft or Leasecraft payload impacts the earth without causing damage to third parties, whichever occurs last. If third parties are damaged, the "risk period" ends immediately after all such damage occurs.
    - c. The "risk period" for Fairchild ends prior to launch of a Leasecraft or Leasecraft payload upon completion of removal of the Leasecraft or Leasecraft payload from the orbiter for any reason and shall begin again upon start of physical attachment as described in Subparagraph B.1.a above.
2. Fairchild shall obtain, at no cost to NASA, insurance protecting Fairchild and the United States Government from any third party Liability for any damage resulting from a deployable Leasecraft or Leasecraft payload element following deployment. A Leasecraft or Leasecraft payload that remains tethered to the Orbiter shall not be considered to have been deployed.
3. The insurance policy may take into account the agreement by NASA, Fairchild and other identified persons, in Paragraph C below, not to make a claim for damage under the conditions described therein. The insurance policy shall provide for the right of the United States Government to settle reasonably a claim for damage after consultation with Fairchild.
4. The amount of insurance and terms and conditions of such insurance to be purchased pursuant to this Paragraph 2.B. shall be agreed to by Fairchild and NASA in view of the insurance available in the world market at a reasonable premium. Notwithstanding such agreement by NASA, Fairchild shall have the responsibility to meet the requirements in Subparagraphs B.1 and B.2 above. Although NASA may agree to an

insurance policy, such agreement shall not result in Fairchild being relieved of its obligation to protect the United States Government by an enforceable insurance policy in the amount agreed upon without exclusions or other limitations which reduce or eliminate the protection of the United States Government, except that the Policy need not protect the United States Government for Liability that falls within the following standard exclusions, but only to the extent NASA agreed in writing to the wording of these standard exclusions: (i) war-risk, (ii) nuclear risks, (iii) Shuttle-caused pollution, (iv) Shuttle-caused interference with radio frequencies, and (v) Worker's compensation, unemployment compensation, death or disability benefits law or equal opportunity laws. As to any individual customer, such insurance shall not be required in an amount in excess of 500 million dollars (U.S.). Where multiple customers are on the same Shuttle flight and are named insureds under a single policy, such insurance shall not be required in an amount in excess of one billion dollars (U.S.). However, if Fairchild or multiple customers obtain insurance in excess of that amount, the United States Government and other insureds shall be protected by the total amount of insurance. Fairchild shall provide to NASA a copy of the executed insurance policy (or policies), or other evidence thereof satisfactory to NASA, within a reasonable time before the Firm Launch Date.

5. a. Under section 308 of the National Aeronautics and Space Act of 1958, as amended by Public Law 96-48, for purposes solely of Subparagraph B.1 above, if NASA determines that it is not feasible for Fairchild to obtain adequate insurance, or if NASA determines that Fairchild is unable to obtain adequate insurance, NASA may provide Fairchild insurance and/or indemnification for a reasonable fee to be agreed upon by Fairchild and NASA.
- b. Under Section 308, NASA agrees to indemnify Fairchild, at no additional cost, for liability incurred by Fairchild solely under subparagraph B.1 above, but only to the extent it is in

excess of the maximum dollar limitation on insurance coverage stated in the insurance policy purchased by or provided to Fairchild. However, if a standard exclusion agreed to by NASA pursuant to subparagraph B.4 (iii) and B.4 (iv) above is applicable to the claim, NASA agrees to indemnify Fairchild at no additional costs, for the liability incurred by Fairchild solely under subparagraph B.1 above. For purposes of this subparagraph B.5.b, "Liability" shall not include payments made by Fairchild:

- (1) which are within the deductible amounts of Fairchild's insurance policy, or
  - (2) which are not covered by insurance because of a limitation or exclusion in the insurance policy, except for (i) the maximum dollar limitation on coverage stated in the insurance policy, or (ii) a standard exclusion agreed to by NASA pursuant to subparagraphs B.4 (iii) and B.4 (iv) above, or
  - (3) to Fairchild's contractor or subcontractor for liability incurred by that contractor or subcontractor, or
  - (4) as settlement payments, unless such payments are agreed to by the United States Government.
- c. (1) No payment shall be made by the United States Government under this Subparagraph B.5 unless the NASA Administrator's designee certifies that the amount is just and reasonable.
- d. Fairchild shall (i) promptly notify the General Counsel of NASA of any claims or suit against Fairchild for the death, bodily injury, or loss of or damage to property which reasonably may be expected to involve indemnification under this Subparagraph B.5, (ii) furnish evidence or proof of any

claim, suit or damage covered by this Subparagraph B.5 in the manner and form required by the United States Government, and (iii) immediately furnish to the United States Government copies of all pertinent papers to such claim or suit received by Fairchild.

- e. The United States Government, at its election, may control or assist in the settlement or defense of any such claim or suit. The United States Government may discharge its obligation under this Subparagraph B.5 by making payments to Fairchild or directly to persons to whom Fairchild may be liable.

C. Damage to Persons or Property Involved in STS Operations

- 1. For purposes of this paragraph C., the following definitions shall be applicable:

- a. "STS Operations" shall mean:

- (1) All Space Transportation System activity;
- (2) All payload activity;
- (3) All tangible personal property (including ground support, test, training and simulation equipment) related to (1) and (2) above;
- (4) Research, design, development, test, manufacture, assembly, integration, transportation, or use of any materials related to (1), (2) or (3) above.
- (5) Performance of any services related to (1) through (4) above.

- b. "Protected STS Operations" shall mean a period of time during which STS Operations are being performed as follows:

- (1) Beginning with the signature of an Agreement or Arrangement with NASA for Space Transportation System services and (a) when any employee, payload or property arrives at a United States Government Installation, or (b) during transportation

of such to the installation by a United States Government conveyance or (c) at ingress of such into an Orbiter, for the purpose of fulfilling such Agreement or Arrangement, whichever occurs first.

- (2) Ending with regard to any employee when the employee departs (a) a United States Government Installation, or (b) the Orbiter if it lands at other than such Installation, or (c) a United States Government conveyance which transports the employee from such Installation or Orbiter, whichever occurs last.
  - (3) Ending with regard to a payload or property, not jettisoned or deployed, under the same conditions as set forth in subparagraph C.1.(b.) above.
  - (4) Ending with whichever occurs last with regard to a deployed or jettisoned payload or property (a) after such impacts the Earth; or (b) if retrieved by the Orbiter, under the same conditions set forth in subparagraph C.1.b.(2) above.
2. NASA and Fairchild (the parties) will respectively utilize their property and employees in STS Operations in close proximity to one another and to others. Furthermore, the parties recognize that all participants in STS Operations are engaged in the common goal of meaningful exploration, exploitation and uses of outer space. In furtherance of this goal, the parties hereto agree to a no-fault, no-subrogation, inter-party waiver of liability pursuant to which each party agrees not to bring a claim against or sue the other party or other customers and agrees to absorb the financial and any other consequences for Damage it incurs to its own property and employees as a result of participation in STS Operations during Protected STS Operations, irrespective of whether such Damage is caused by NASA, Fairchild, or other customers participating in STS Operations, and regardless of whether such Damage arises through negligence or otherwise. Thus,

the parties, by absorbing the consequences of damage to their property and employees without recourse against each other or other customers participating in STS Operations during Protected STS Operations, jointly contribute to the common goal of meaningful exploration of outer space.

3. The parties agree that this common goal will also be advanced through extension of the inter-party waiver of liability to other participants in STS Operations. Accordingly, the parties agree to extend the waiver as set forth in subparagraph C.2 above to contractors and subcontractors at every tier of the parties and other customers, as third party beneficiaries, whether or not such contractors or subcontractors causing damage bring property or employees to a United States Government installation or retain title to or other interest in property provided by them to be used, or otherwise involved, in STS Operations. Specifically, the parties intend to protect these contractors and subcontractors from claims, including "products liability" claims, which might otherwise be pursued by the parties, or the contractors or subcontractors of the parties, or other customers or the contractors or subcontractors of other customers. Moreover, it is the intent of the parties that each will take all necessary and reasonable steps in accordance with subparagraph C.4 below to foreclose claims for Damage by any participant in STS Operations during Protected STS Operations, under the same conditions and to the same extent as set forth in subparagraph C.2 above, except for claims between Fairchild and its contractors or subcontractors and claims between the United States Government and its contractors and subcontractors.
4. The parties intend that the inter-party waiver of liability set forth in subparagraph C.2 and C.3 above be broadly construed to achieve the intended objectives.
5. NASA will require all Space Transportation System customers entering into Launch and Associated Services Agreements with NASA

after December 1, 1982, to agree to the inter-party waiver of liability as set forth in subparagraphs C.2 and C.3 above. Fairchild, and each other customer, will require the following to agree to the waiver of liability set forth in subparagraph C.3 above: (a) all persons and entities to whom it assigns all or part of its right to Launch and Associated Services; (b) any person or entity to whom it has sold or leased or otherwise agreed, prior to the completion of NASA's launch services for a particular Payload, to provide all or any portion of its Payload or Payload services; (c) all its prime contractors; and (d) all its subcontractors who will have persons or property involved in STS Operations during Protected STS Operations. NASA will require all the following to agree to the waiver of liability set forth in subparagraph <sup>C.3</sup> 3.c above: (a) all its prime contractors; and (b) all its subcontractors who will have persons or property involved in STS Operations during Protected STS Operations. Furthermore, NASA has required all STS customers entering into Launch and Associated Services Agreements prior to December 1, 1982, to agree to a more limited waiver of liability, a copy of which is available from NASA upon request. Failure of any party or contractor or subcontractor to obtain a waiver agreement required above shall not affect such party's or contractor's or subcontractor's right to the protection otherwise provided by this paragraph C.

D. Fairchild Claims Against the United States Government and Its Contractors

Without affecting the right of Fairchild to pursue the procedure under the Disputes provision set forth in Article XXVII of this Agreement, Fairchild shall not make any claim against the United States Government or the United States Government's contractors and subcontractors for Damage or other relief for any delay (including a Deferral, Delay, Suspension or Postponement) in the provision of any Launch and Associated Services or for the non-performance or improper performance of Launch and Associated Services, including, but not limited to, the performance of the United States Government or the United States Government's contractors and

subcontractors of research, design, development, test, manufacture, assembly, integration, transportation or use of any materials related to STS Operations or in the performance of other services related to STS Operations, except that Fairchild may make a claim for such costs or liquidated damages that may be payable as expressly provided for in the contracts entered into by the United States Government and its contractors and subcontractors for services performed for Fairchild. Except to the extent Fairchild is compensated by insurance or otherwise for Damage, this Paragraph D shall not prevent a claim from being brought by Fairchild (i) against the United States Government or its contractors and subcontractors if Fairchild suffers Damage caused by failure of the United States Government or its contractors and subcontractors to fulfill their obligation to incorporate Paragraph C above, or its equivalent, in an Agreement, Arrangement or Contract, as provided for in Paragraph C above, or (ii) against the United States Government if Fairchild suffers Damage caused by failure of the United States Government or its contractors and subcontractors to fulfill their obligation to protect Fairchild data as specified in Article XII of this Agreement.

E. Limitation of United States Government and Fairchild Liability

Notwithstanding Subparagraph A.2.b above, to the extent that a risk of damage is not dealt with expressly in this Agreement, the United States Government's liability to Fairchild and Fairchild's liability to the United States Government arising out of this Agreement, whether or not arising as a result of an alleged breach of this Agreement, shall be limited to direct damages only and shall not include any loss or revenue, profits or other indirect or consequential damages.

F. Damage to the Payload or Associated Property

The United States Government shall not be responsible for damage to the Payload or associated property of Fairchild, any party in privity therewith, Fairchild's users, or their contractors or subcontractors,

which property is provided pursuant to this Joint Endeavor. Fairchild



agrees to indemnify the United States Government for any liability incurred by the United States Government as a result of such damage.

G. Product Liability

Fairchild agrees to indemnify the Government for any costs incurred by the Government as a result of damage caused by a process, material, service or other product of a Leasecraft payload, which may arise out of this Agreement.

XXV - REVISIONS

This agreement may be modified, in whole or in part, by mutual agreement between the parties. Only the signatories of this agreement or their designees shall have the authority to execute any such amendments to this Agreement.

ARTICLE XXVI - APPLICABLE LAW

Fairchild Industries, Germantown, Maryland, and the National Aeronautics and Space Administration (NASA) hereby designate the United States Federal Law to govern this Agreement for all purposes, including but not limited to determining the validity of this Agreement, the meaning of its provisions and the rights, obligations and remedies of the parties.

ARTICLE XXVII - DISPUTES

- A. Any dispute arising under this Agreement which is not disposed of by agreement of the two JEMs shall be submitted jointly to the signatories of this Agreement. A joint decision of the signatories or their designees shall be the disposition of such dispute.
  
- B. With respect solely to claims that may be made against NASA or its contractors or subcontractors, pursuant to subparagraph D. of Article XXIV, if within a reasonable period of time (120 days) after submission of a dispute for resolution the signatories of this agreement are unable to jointly resolve a dispute, the dispute will be considered to have become a "claim" within the meaning of the "Contract Disputes Act of 1978" (P.L. 95-563); and the parties agree to be bound by the provisions thereof. In this regard, the parties expressly recognize the opportunity for such claims to be pursued either before the NASA Board of Contract Appeals or the United States Court of Claims, at the election of Fairchild.
  
- C. Pending the resolution of any dispute or claim pursuant to this ARTICLE XXVII, the parties agree that performance of all obligations shall be pursued diligently in accordance with the direction of the NASA signatory.

ARTICLE XXVIII - NOTICES

Any notice to be given hereunder shall be in writing and shall be sent by registered or certified mail, postage prepaid, to the parties at the following addresses or at such addresses as the respective parties may from time to time designate in writing:

National Aeronautics and Space Administration  
Attention: Administrator  
Washington, D. C. 20546

Fairchild Industries, Inc.  
Attention: Chairman and Chief Executive Officer  
Germantown, MD 20874

## Appendix A

### FAIRCHILD LEASECRAFT GENERAL DESCRIPTION

This section presents a brief description of the standard Fairchild Leasecraft (FLC) spacecraft. The vehicle as shown in Figure A-1 is made up of the following items.

1. Spacecraft structure with interfaces for payload and at least 8 modules of the Multi-mission Modular spacecraft type
2. Up to 5 Power Modules (MPS)
3. 1 - Communications & Data Handling Module (C&DH)
4. 1 - Modular Attitude Control System (MACS)
5. 1 - Special Function Module
6. 1 - TDRSS Antenna Assembly
7. 1 - Payload Module

Four of the MPS modules can be replaced with Payload Modules. The structure internally supports a propulsion module based on the Mark II, 4-tank hydrazine propulsion system. FLC also has a modularized solar array which can be incrementally deployed. The solar array is sized at 1320 ft<sup>2</sup> in a symmetric deployment about the roll axis. At least one panel of the array can be double-gimballed to support earth-pointing or inertial-reference missions.

A summary of the FLC functional requirements is presented in Figure 2. The general performance requirements are summarized in Figure A-3. The system electrical block diagram is shown in Figure A-4.

Some of the key operational features of the Leasecraft system are shown in Figure A-5, while Figure A-6 summarizes some of its unique cost-saving and service features.

Leasecraft, without payload is approximately 15 feet long, 15 feet wide and 14.5 feet high and weighs 20,000 pounds loaded.

# FAIRCHILD LEASECRAFT CONCEPTUAL DESIGN

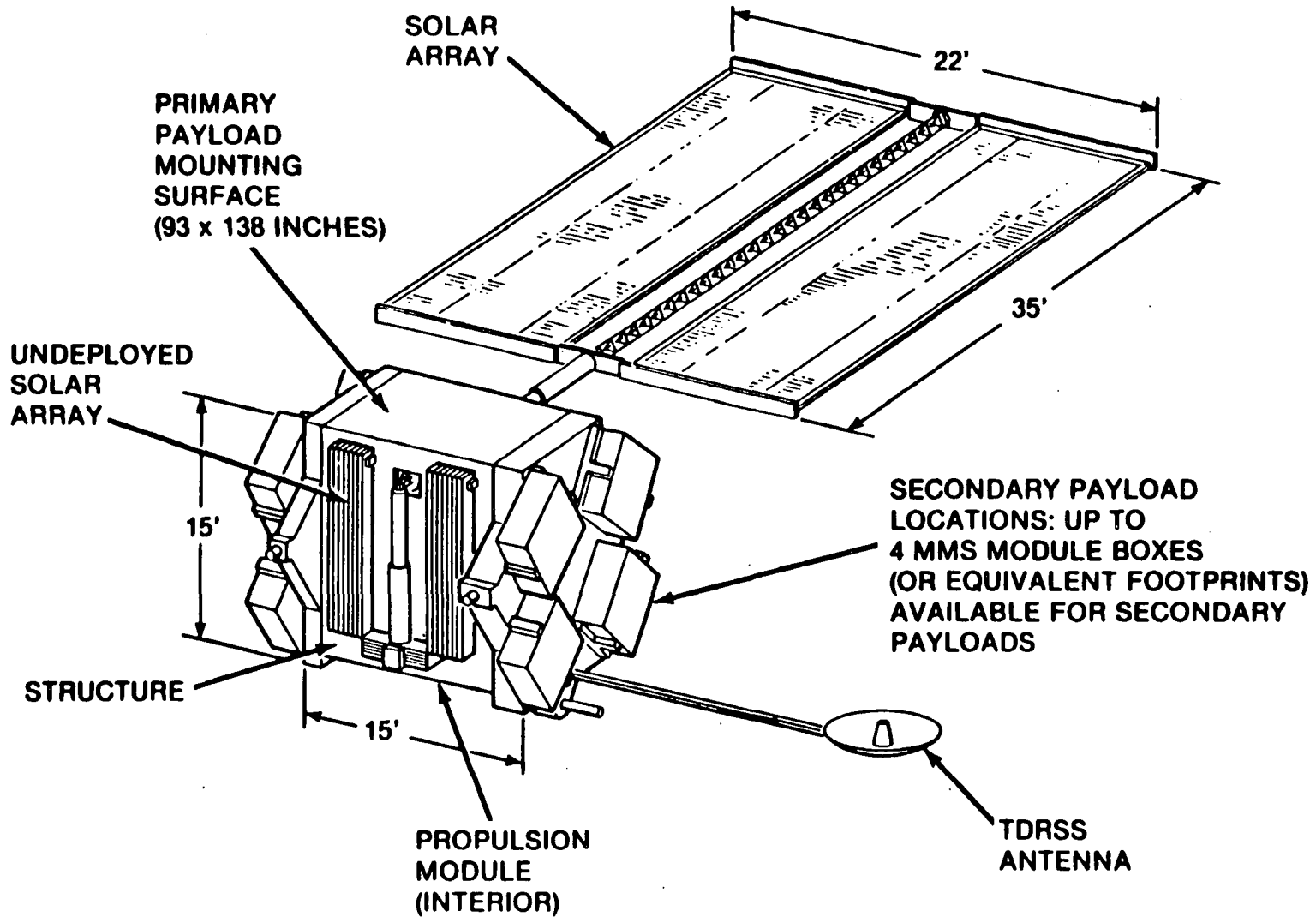

Figure A-1. Fairchild Leasecraft Space Vehicle



- UP TO 7,300 WATTS OF ELECTRICAL POWER IN FIVE INCREMENTS
- TWO-WAY TRANSFER 20,000 LBS. TO 360 N. MILES; 4,000 LBS. TO 600 N. MILES
- TDRSS, STDN OR SGLS COMPATIBLE COMMUNICATION LINKS
- ATTITUDE ERROR < .01° WITH ATTITUDE RATE < .002°/SEC
- AUTONOMOUS OPERATION
- DUAL REDUNDANT (NO SINGLE POINT FAILURES)
- CAPABLE OF BEING LAUNCHED & RETRIEVED BY STS
- DIRECT SPACEFRAME ATTACHMENT TO STS LONGERON & KEEL FITTINGS
- UTILIZE STANDARD MMS MODULES
- ALL MODULES & MAJOR SUB-ASSEMBLIES EXCHANGEABLE IN SPACE ENVIRONMENT
- LEASECRAFT MATED TO PAYLOAD IN ORBIT
- MATING, DEPLOYMENT, RETRIEVAL & CHANGEOUT TIMELINE'S MINIMIZED
- MAXIMUM USE OF RMS FOR SERVICE OPERATIONS

Figure A-2. Leasecraft Functional Requirements

PAYLOAD WEIGHT CAPABILITY _____	PRIMARY PAYLOAD UP TO 14,500 kg (32,000 LBS.) SECONDARY PAYLOADS: UP TO 1,000 kg (2,200 LBS.)	} APPROXIMATE
TYPES OF MISSIONS _____	STELLAR, SOLAR, EARTH POINTED, OR SPECIAL PURPOSE MISSIONS. LOW EARTH ORBITS, INERTIAL POINTED OR PAYLOAD POINTED	
OPERATING ORBITAL ALTITUDE _____	LOW EARTH ORBITS, ALL INCLINATIONS $\geq 28.5$ DEG	
LIFE EXPECTANCY/REDUNDANCY _____	ALL CRITICAL ELEMENTS REDUNDANT, ALL SUBSYSTEMS REPLACEABLE IN ORBIT NO SINGLE POINT FAILURE TO PREVENT RESUPPLY OR RETRIEVAL BY SHUTTLE.	
LAUNCH VEHICLE _____	SPACE SHUTTLE FOR LAUNCH, SERVICE, AND RETRIEVAL.	

**COMMUNICATIONS AND DATA HANDLING SUBSYSTEM**

TRANSPONDER _____	S-BAND STDN/TDRSS, TRANSPONDER OUTPUT POWER AT MODULE INTERFACE 0.8, 2.0, 4.0 WATTS, SELECTABLE AT MANUFACTURE.
COMMAND RATES _____	2 KBPS (SHUTTLE/STDN), 125 and 1 KBPS SELECTABLE (TDRSS).
REAL-TIME TELEMETRY RATES _____	1, 2, 4, 8, 16, 32, 64 KBPS
TELEMETRY FORMATS _____	2 SELECTABLE PRIOR TO LAUNCH, PLUS IN-ORBIT PROGRAMMABLE CAPABILITY. ALL FORMATS CONTAIN 890 DATA WORD MAXIMUM.
STORED DATA DUMP/MISSION DATA SOURCE _____	2,048 MBPS MAXIMUM, 1,024 MBPS CODED DATA, UP TO 100 MBPS IN OPTIONAL WIDEBAND DATA MODULE.
ON-BOARD COMPUTER _____	18 BITS PER WORD, 32K WORDS OF MEMORY, BASELINE EXPANDABLE TO 64K WORDS 5 MICROSECOND ADD TIME.
DATA STORAGE _____	10 <sup>6</sup> OR 10 <sup>8</sup> BIT TAPE RECORDERS.

**ATTITUDE CONTROL SYSTEMS**

TYPE _____	3-AXIS STABILIZED, ZERO MOMENTUM
ATTITUDE REFERENCE (WITHOUT PAYLOAD SENSOR) _____	STELLAR (INERTIAL)
POINTING ERROR (ONE SIGMA) WITHOUT PAYLOAD SENSOR _____	$< 10^{-2}$ DEG.
WITH PAYLOAD SENSOR (IDEAL) _____	$< 10^{-6}$ DEG.
POINTING STABILITY (ONE SIGMA) AVERAGE RATE _____	$< 10^{-6}$ DEG./SEC.
JITTER WITHOUT PAYLOAD SENSOR _____	$< 6 \times 10^{-4}$ DEG (20 MINUTE PERIOD)
WITH PAYLOAD SENSOR (IDEAL) _____	$< 10^{-6}$ DEG.
SLEW RATE _____	MAXIMUM 1.6°/SEC WITH STANDARD INERTIAL REFERENCE UNIT

**POWER SUBSYSTEM (BASELINE - 1 MODULE - UP TO 5 MODULES AVAILABLE)**

VOLTAGE OUTPUT _____	+28 $\pm$ 7 VDC
POWER TO PAYLOADS (MAX) _____	1,000, 2,600, 4,200, 5,700, 7,300 WATTS (1 - TO - 5 POWER MODULES)
BATTERIES _____	TWO 20 - AMPERE - HOUR BATTERIES TO THREE 60 - AMPERE - HOUR BATTERIES PER POWER MODULE

**PROPULSION SYSTEM**

MK II 4 - TANK HYDRAZINE SYSTEM CAPABLE OF CARRYING 2700 kg (6000 LBS.) 4 - 445N (100 LB.) ORBIT ADJUST THRUSTERS, 12-22.2N (5 LB.) RCS THRUSTERS

**PROPULSION SYSTEM**

MK II 4-TANK HYDRAZINE SYSTEM CAPABLE OF CARRYING 2700 kg (6000 LBS.) 4-445N (100 LB.) ORBIT ADJUST THRUSTERS, 12-22.2N (5 LB.) RCS THRUSTERS.

Figure A-3. Leascraft Performance Summary

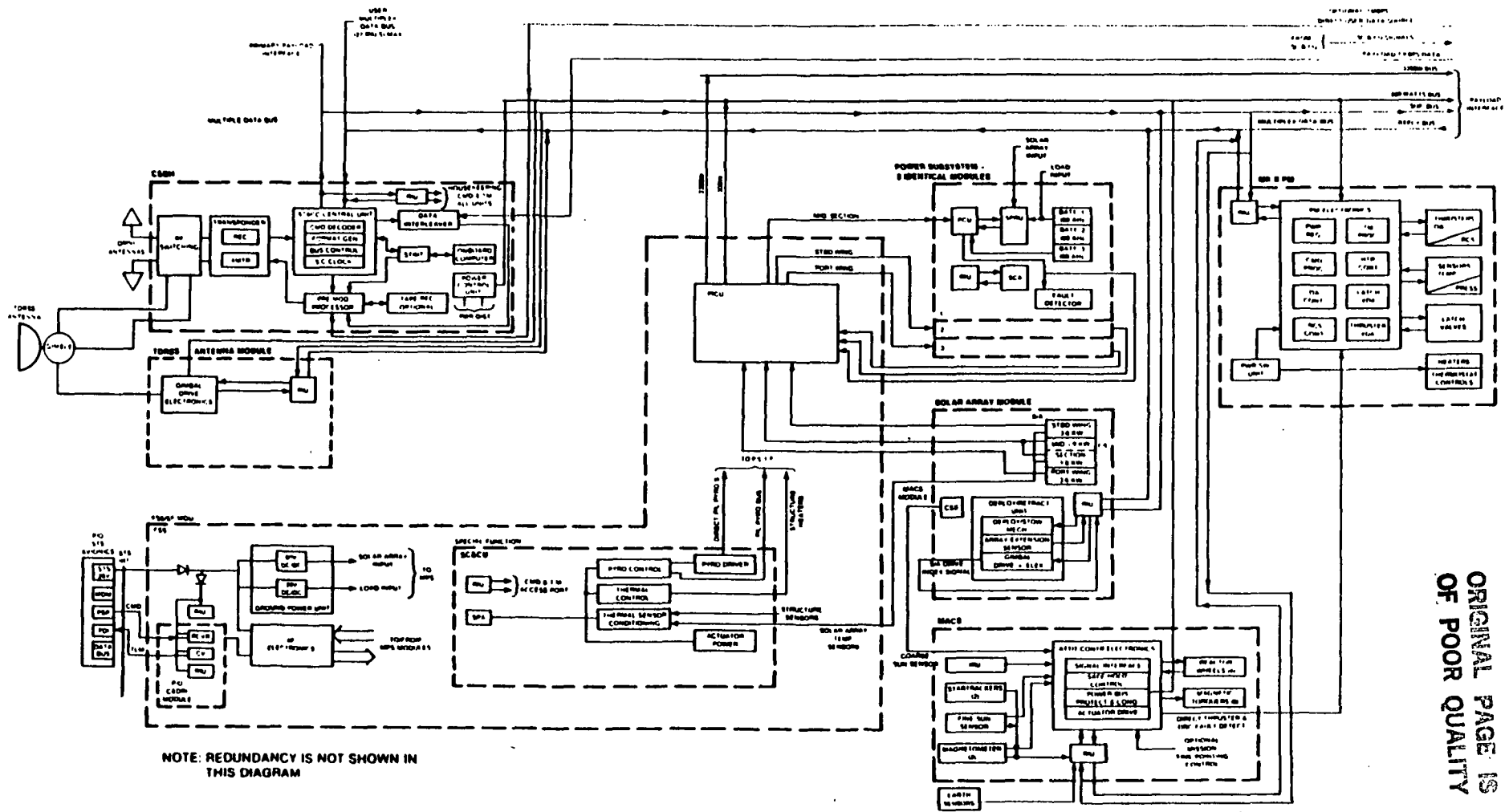

Figure A-4. Fairchild Leascraft System Block Diagram

- DESIGNED FOR SHUTTLE TENDING
  - SPACECRAFT PERMANENTLY IN ORBIT - RETURNS TO SHUTTLE FOR SERVICING & PAYLOAD CHANGEOUTS; AVOIDS ADDED LAUNCH COSTS
  - USES ALREADY-DEVELOPED SHUTTLE SERVICING TECHNIQUES AND HARDWARE; TO BE PROVEN ON SMM REPAIR MISSION
  - SYSTEM INCLUDES:
    - SPACECRAFT CONTROL SEGMENT
    - DATA OR PRODUCT TRANSFER TO USER
    - PAYLOAD HANDLING AT CAPE & IN ORBIT
    - OPTIONAL SERVICES, HARDWARE, SOFTWARE FOR SPECIAL USES
    - COMPANY-EMPLOYED MISSION-SPECIALIST CREW
  - APPLICABLE TO MAJOR PAYLOADS; DEDICATED FLIGHTS AND TO MULTIPLE-PAYLOADS; SHARED FLIGHTS
- 

Figure A-5. Leasecraft System - Key Features

### LOW COST

- COMMERCIALY PRODUCED HARDWARE AND SERVICES
- MINIMUM COST THROUGH ON-GOING PRODUCTION OF STANDARD SPACECRAFT ELEMENTS
- PAYLOAD CHANGEOUT AND REPAIR ON ORBIT
- MOBILITY TO AND FROM SHUTTLE PARKING ORBIT

### SERVICES

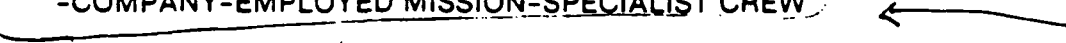
- GUARANTEED SERVICES PAID FOR AS THE CUSTOMER RECEIVES IT
- COMPLETE "PORTAL TO PORTAL" SERVICE

### CAPABILITIES

- HIGH POWER, HEAVY PAYLOAD, FINE POINTING
- CONVERTIBLE CONFIGURATIONS ON GROUND OR IN SPACE

Figure A-6. Unique Features of the Leasecraft Concept

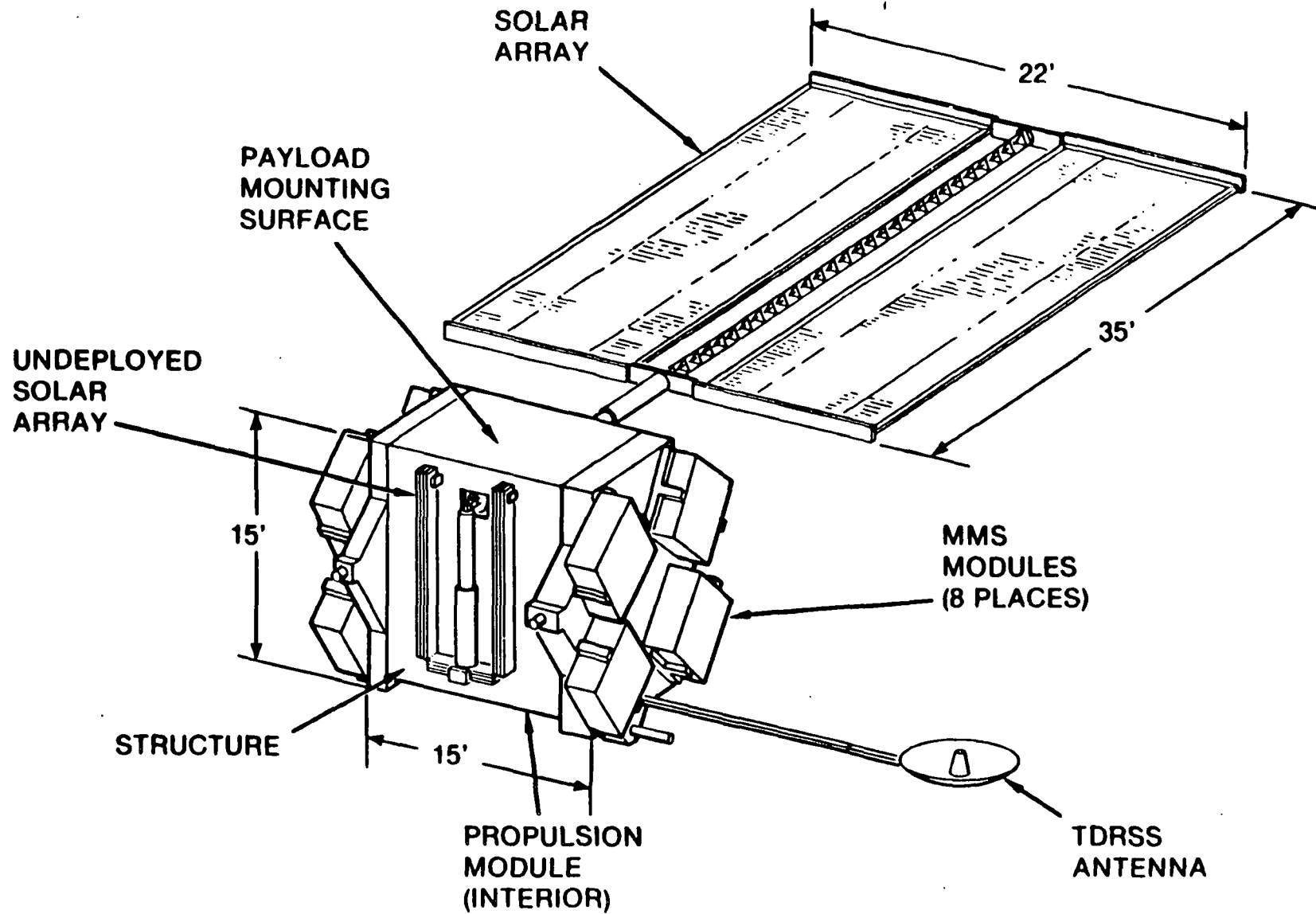

Figure A-1. Fairchild Leasecraft Space Vehicle

- UP TO 6,600 WATTS OF ELECTRICAL POWER IN 1650W INCREMENTS
- TWO-WAY TRANSFER 20,000 LBS. TO 360 N. MILES; 4,000 LBS. TO 600 N. MILES
- TDRSS, STDN OR SGLS COMPATIBLE COMMUNICATION LINKS
- ATTITUDE ERROR  $< .01^\circ$  WITH ATTITUDE RATE  $< .002^\circ/\text{SEC}$
- AUTONOMOUS OPERATION
- DUAL REDUNDANT (NO SINGLE POINT FAILURES)
- CAPABLE OF BEING LAUNCHED & RETRIEVED BY STS
- COST-EFFECTIVE UTILIZATION OF STS CARGO BAY (1,100 LB./FT.)
- DIRECT SPACEFRAME ATTACHMENT TO STS LONGERON & KEEL FITTINGS
- UTILIZE STANDARD MMS MODULES
- ALL MODULES & MAJOR SUB-ASSEMBLIES EXCHANGEABLE IN SPACE ENVIRONMENT
- LEASECRAFT MATED TO PAYLOAD IN ORBIT
- MATING, DEPLOYMENT, RETRIEVAL & CHANGEOUT TIMELINE'S MINIMIZED
- MAXIMUM USE OF RMS FOR SERVICE OPERATIONS

Figure A-2. Leasecraft Functional Requirements

PAYLOAD WEIGHT CAPABILITY	PRIMARY PAYLOAD: UP TO 14,500 kg (32,000 LBS.) SECONDARY PAYLOADS: UP TO MMS MODULE CAPABILITY
TYPES OF MISSIONS	STELLAR, SOLAR, EARTH POINTED, OR SPECIAL PURPOSE MISSIONS. LOW EARTH ORBITS; INERTIAL POINTED OR PAYLOAD POINTED.
OPERATING ORBITAL ALTITUDE	LOW EARTH ORBITS, ALL INCLINATIONS.
LIFE EXPECTANCY/REDUNDANCY	ALL CRITICAL ELEMENTS REDUNDANT; REPLACEABLE IN ORBIT. NO SINGLE POINT FAILURE TO PREVENT RESUPPLY OR RETRIEVAL BY SHUTTLE WITHIN 6 MONTHS.
LAUNCH VEHICLE	FULLY SHUTTLE COMPATIBLE FOR LAUNCH, SERVICE, AND RETRIEVAL.
<b>COMMUNICATIONS AND DATA HANDLING SUBSYSTEM</b>	
TRANSPONDER	S-BAND STDN/DRSS, TRANSPONDER OUTPUT POWER AT MODULE INTERFACE 0.8, 2.0, 4.0 WATTS, SELECTABLE AT MANUFACTURE.
COMMAND RATES	2 KBPS (SHUTTLE/STDN), 125 AND 1 KBPS SELECTABLE (DRSS).
REAL-TIME TELEMETRY RATES	1, 2, 4, 8, 16, 32, 64 KBPS.
TELEMETRY FORMATS	2 SELECTABLE PRIOR TO LAUNCH. PLUS IN-ORBIT PROGRAMMABLE CAPABILITY: ALL FORMATS CONTAIN 890 DATA WORD MAXIMUM.
STORED DATA DUMP/MISSION DATA SOURCE	2.048 MBPS MAXIMUM. 1.024 MBPS CODED DATA. UP TO 80 MBPS IN OPTIONAL WIDEBAND DATA MODULE.
ON-BOARD COMPUTER	18 BITS PER WORD. 32K WORDS OF MEMORY, BASELINE EXPANDABLE TO 64K WORDS. 5 MICROSECOND ADD TIME.
DATA STORAGE	STANDARD OPTION OF $10^8$ AND $10^9$ BIT TAPE RECORDERS.
<b>ATTITUDE CONTROL SYSTEMS</b>	
TYPE	3-AXIS STABILIZED, ZERO MOMENTUM
ATTITUDE REFERENCE (WITHOUT PAYLOAD SENSOR)	STELLAR (INERTIAL)
POINTING ERROR (ONE SIGMA) WITHOUT PAYLOAD SENSOR	$< 10^{-2}$ DEG.
WITH PAYLOAD SENSOR (IDEAL)	$< 10^{-5}$ DEG.
POINTING STABILITY (ONE SIGMA) AVERAGE RATE	$< 10^{-6}$ DEG./SEC.
JITTER WITHOUT PAYLOAD SENSOR	$< 6 \times 10^{-4}$ DEG. (20 MINUTE PERIOD)
WITH PAYLOAD SENSOR (IDEAL)	$< 10^{-6}$ DEG.
SLEW RATE	MAXIMUM 1.6°/SEC WITH STANDARD INERTIAL REFERENCE UNIT
<b>POWER SUBSYSTEM (BASELINE - 1 MODULE - UP TO 3 MODULES AVAILABLE)</b>	
VOLTAGE OUTPUT	+ 28 ± 7 VDC COARSELY REGULATED
POWER OUTPUT	1650 WATTS AVERAGE (1250W AVAILABLE TO USER). UP TO 6600 WATTS
BATTERIES	TWO 20-AMPERE-HOUR BATTERIES AS BASELINE: UP TO THREE 50-AMPERE-HOUR BATTERIES MAXIMUM.
<b>PROPULSION SYSTEM</b>	
	MK II 4-TANK HYDRAZINE SYSTEM CAPABLE OF CARRYING 2700 kg (6000 LBS.) 4-445N (100 LB.) ORBIT ADJUST THRUSTERS, 12-22.2N (5 LB.) RCS THRUSTERS.

Figure A-3. Leascraft Performance Requirements



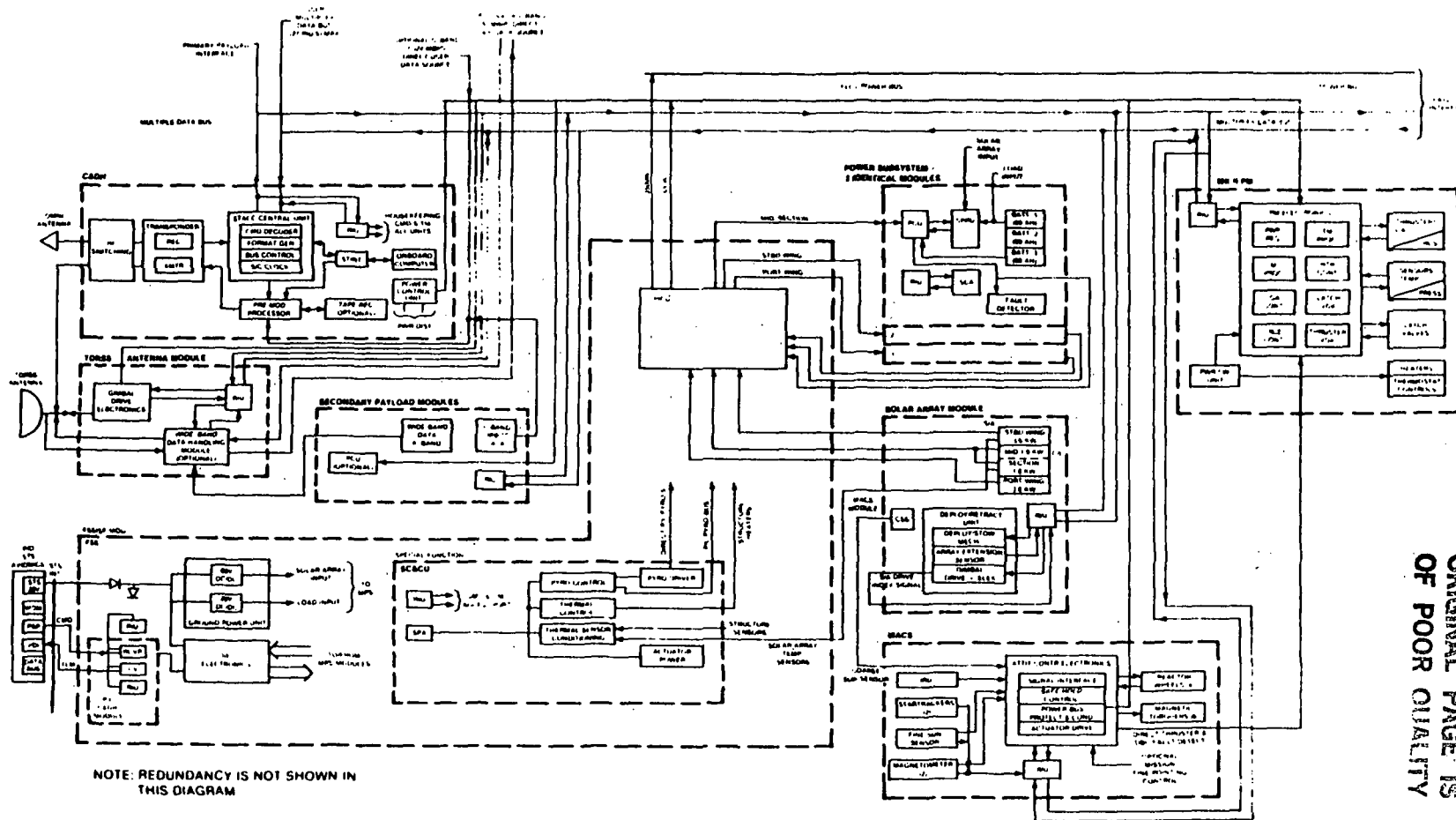

ORIGINAL PAGE IS  
OF POOR QUALITY

Figure A-4. Fairchild Leasecraft System Block Diagram

- **DESIGNED FOR SHUTTLE TENDING**
- **SPACECRAFT PERMANENTLY IN ORBIT - RETURNS TO SHUTTLE FOR SERVICING & PAYLOAD CHANGEOUTS; AVOIDS ADDED LAUNCH COSTS**
- **USES ALREADY-DEVELOPED SHUTTLE SERVICING TECHNIQUES AND HARDWARE; TO BE PROVEN ON SMM REPAIR MISSION**
- **SYSTEM INCLUDES:**
  - SPACECRAFT CONTROL SEGMENT
  - DATA OR PRODUCT TRANSFER TO USER
  - PAYLOAD HANDLING AT CAPE & IN ORBIT
  - OPTIONAL SERVICES, HARDWARE, SOFTWARE FOR SPECIAL USES
  - COMPANY-EMPLOYED PAYLOAD-SPECIALIST CREW
- **APPLICABLE TO MAJOR PAYLOADS; DEDICATED FLIGHTS AND TO MULTIPLE-PAYLOADS; SHARED FLIGHTS**

**Figure A-5. Leasecraft System - Key Features**

### LOW COST

- COMMERCIALY PRODUCED HARDWARE AND SERVICES
- MINIMUM COST THROUGH ON-GOING PRODUCTION OF STANDARD SPACECRAFT ELEMENTS
- PAYLOAD CHANGEOUT AND REPAIR ON ORBIT
- MOBILITY TO AND FROM SHUTTLE PARKING ORBIT

### SERVICES

- GUARANTEED SERVICES PAID FOR AS THE CUSTOMER RECEIVES IT
- COMPLETE "PORTAL TO PORTAL" SERVICE

### CAPABILITIES

- HIGH POWER, HEAVY PAYLOAD, FINE POINTING
- CONVERTIBLE CONFIGURATIONS ON GROUND OR IN SPACE

Figure A-6. Unique Features of the Leasecraft Concept

**APPENDIX 4**

**LEASECRAFT MISSION SCENARIO**

# In-Orbit Operational Sequence

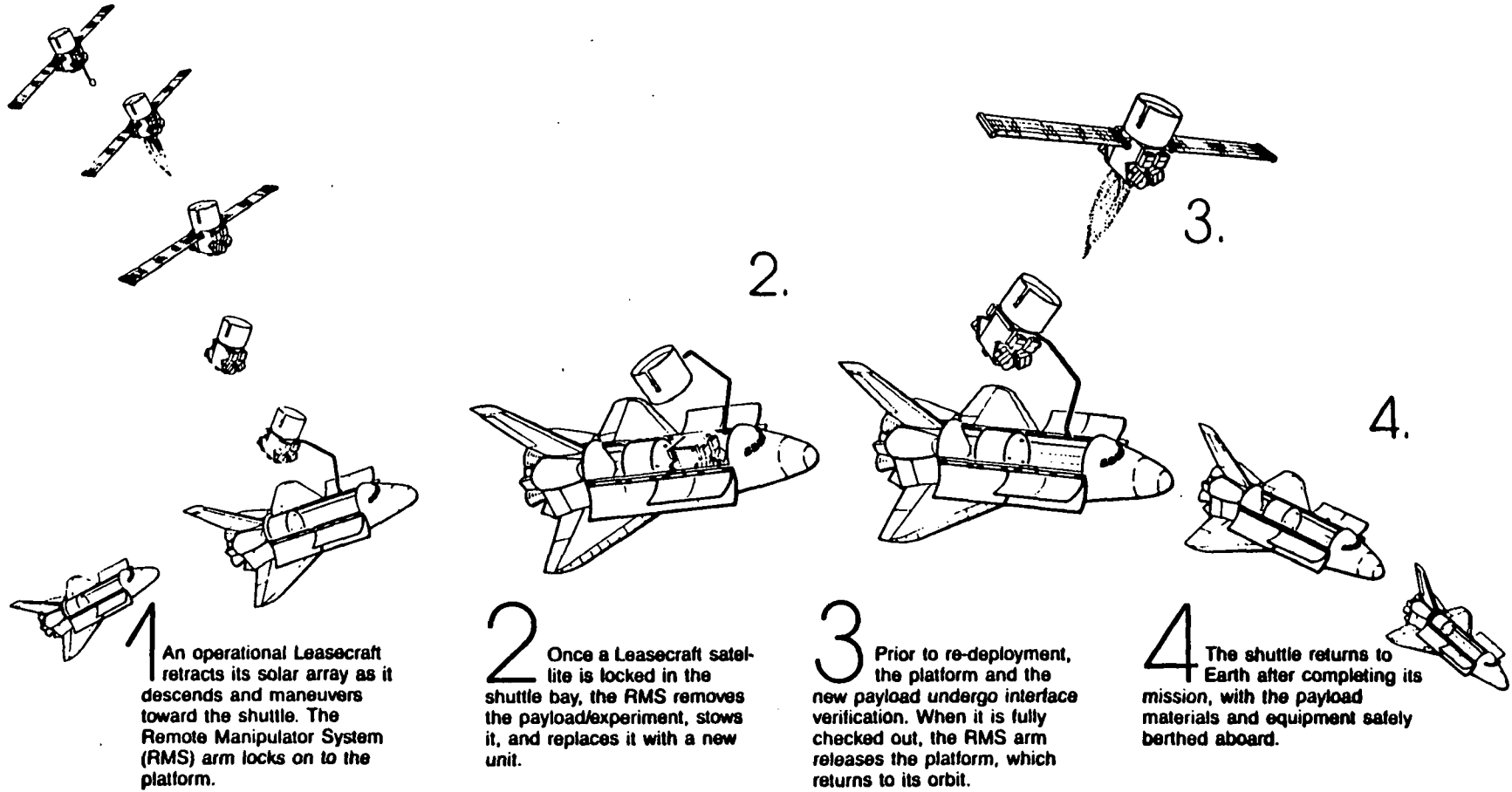

**ORIGINAL PAGE IS  
OF POOR QUALITY**

**APPENDIX 5**

**SELECT CITATIONS AND ABSTRACTS**

To compliment the preceding study, the Center has compiled a collection of database abstracts dealing with various aspects of space commercialization. The following abstracts were reprinted with the permission of the copyright owners. Each section is preceded by a cover sheet detailing copyright restrictions on the material. Reproduction of this material is prohibited without the express written authorization of the copyright owner.

ORIGINAL PAGE IS  
OF POOR QUALITY

### AEROSPACE DATABASE

Bibliographical information contained in the following section was obtained via online search of the Aerospace Database, available on the DIALOG information system as File 108. The items reproduced herein with the permission of the Technical Information Service division of the American Institute of Aeronautics and Astronautics.

The Aerospace Database is the combined electronic form of two semi-monthly abstract/index periodicals:

- IAA: International Aerospace Abstracts. Published by the American Institute of Aeronautics and Astronautics - Technical Information Service and sponsored by NASA.

- STAR: Scientific and Technical Aerospace Reports  
Published by NASA's Scientific and Technical Information Branch.

Most documents cited in the database are available in photocopy or microfiche form, and may be obtained from the AIAA Library. For more information on the AEROSPACE DATABASE, document delivery, or other AIAA/TIS products and services contact:

Marketing Department  
AIAA/Technical Information Service  
555 West 57th Street, Suite 1200  
New York, NY 10019  
212-582-4901 or 247-6500

## DIALOG File 108: AEROSPACE - 82-86/ISS09

1433057 A86-22267

**Satellite leasing - Cheap access to space**

MAEHL, R. (RCA, Astro-Electronics Div., Princeton, NJ)

Space (ISSN 0267-954X), vol. 1, Dec. 1985-Feb. 1986, p. 10, 11, 17.

Publication Date: Feb. 1986

Language: English

Country of Origin: United States Country of Publication: United Kingdom

Document Type: JOURNAL ARTICLE

Most documents available from AIAA Technical Library

Journal Announcement: IAA8608

The role of satellite leasing arrangements in marketing commercial ventures in space is considered. The most recent examples of leased space platforms are described, including Leasat; ESA's EURECA; Omnistar; and Leasecraft. It is shown that because of NASA Shuttle pricing policies, leasing room for commercial payloads on board space platforms will become an increasingly attractive way of financing space ventures in which capital investments are often at risk. The development of the first large-scale commercial space platform for the Electrophoresis in Space (EOS) program is also discussed. (I.H.)

Source of Abstract/Subfile: AIAA/TIS

Descriptors: \*LEASING; \*SPACE COMMERCIALIZATION; \*SPACE PLATFORMS; \*SPACE PROCESSING; MARKETING; SPACE TRANSPORTATION SYSTEM

Subject Classification: 7581 .Administration & Management (1975-)

1422448 A86-15638

**Microgravity environment quality aboard a low earth orbit Space Station**

BOUDREAU, R. (Canadian Astronautics, Ltd., Ottawa, Canada)

IAF, International Astronautical Congress, 36th, Stockholm, Sweden, Oct. 7-12, 1985. 15 p.

Publication Date: Oct. 1985 21 Refs.

Report No.: IAF PAPER 85-53

Language: English

Country of Origin: Canada Country of Publication: International Organization

Document Type: PREPRINT

Most documents available from AIAA Technical Library

Journal Announcement: IAA8604

The importance of the microgravity environment in material processing in space (MPS) is discussed. The features that make microgravity useful for MPS, which are the reduction of buoyancy driven convection, containerless processing, and the elimination of sedimentation, are described. A comparison of the operating characteristics of the Space Shuttle, Space Station, EURECA, and Leasecraft microgravity support systems is provided. The calculation of the proper MPS spacecraft geometry which minimizes microgravity contamination is described and microgravity acceleration values for the spacecraft studied are given. The effect of atmospheric drag and crew operations on the quality of microgravity is

investigated. An example revealing the importance of the proper microgravity environment is presented. (I.F.)

Source of Abstract/Subfile: AIAA/TIS

Descriptors: \*EARTH ORBITAL ENVIRONMENTS; \*MICROGRAVITY APPLICATIONS; \*SPACE PROCESSING; \*SPACE STATIONS; AERODYNAMIC FORCES; CONTAINERLESS MELTS; CORIOLIS EFFECT; MATERIALS SCIENCE; SOLAR WIND

Subject Classification: 7512 .Astronautics--General (1975-)

1395606 A85-39464

**Leasecraft power system**

CHETTY, P. R. K. (Fairchild Space Co., Germantown, MD)

IEEE Transactions on Aerospace and Electronic Systems (ISSN 0018-9251), vol. AES-21, May 1985, p. 420-426.

Publication Date: May 1985

Language: English

Country of Origin: United States Country of Publication: United States

Document Type: JOURNAL ARTICLE

Most documents available from AIAA Technical Library

Journal Announcement: IAA8518

A detailed description is presented of the power system of Leasecraft, a satellite platform for low earth orbit missions to facilitate commercial development of space. Typical spacecraft power systems are first briefly reviewed, and the results of tradeoff studies are reported which led to the selection of a decentralized regulation concept utilizing a nondissipative unregulated main bus approach to the Leasecraft power system. The need for modularity is discussed, and the modular power system is addressed, including the power regulator unit, power control unit, bus protection assembly, signal conditioning assembly, storage batteries, remote interface unit, and heaters. (C.D.)

Source of Abstract/Subfile: AIAA/TIS

Descriptors: \*COMMERCIAL SPACECRAFT; \*POWER CONDITIONING; \*SATELLITE DESIGN; \*SOLAR ARRAYS; \*SPACE PLATFORMS; \*SPACECRAFT POWER SUPPLIES; BUS CONDUCTORS; POWER CONVERTERS; POWER EFFICIENCY; SPACECRAFT MODULES; TRADEOFFS

Subject Classification: 7520 .Spacecraft Propulsion & Power (1975-)

1328769 A84-49146

**Leasecraft - A commercial space platform**

BURROWBRIDGE, D. R. (Fairchild Space Co., Germantown, MD)

IN: Satellite land remote sensing advancements for the eighties; Proceedings of the Eighth Pecora Symposium, Sioux Falls, SD, October 4-7, 1983 (A84-49131 24-43). Sioux Falls, SD, Augustana College, 1984, p. 228-243.

Publication Date: 1984

Language: English

Country of Origin: United States Country of Publication: United States

Document Type: CONFERENCE PAPER

(cont. next page)



## DIALOG File 108: AEROSPACE - 62-86/ISS09

Most documents available from AIAA Technical Library  
Journal Announcement: IAA8424

The Multimission Modular Spacecraft (MMS) is the result of a NASA program concerned with the identification of new approaches to spacecraft design. A mandatory requirement regarding the MMS was flexibility to accommodate a wide variety of payloads. MMS derived subsystems will provide a platform in low orbit for scientific, commercial, and government users on a leased or service contract basis. The payload may consist of scientific instruments, materials processing equipment, or remote sensors. Secondary payloads may be mounted in standard MMS module boxes. The platform forms a part of the 'Leasecraft' system, which was developed by an American aerospace company. Attention is given to the Leasecraft vehicle, details regarding the Leasecraft platform, and payload accommodations and Leasecraft missions. (G.R.)

Source of Abstract/Subfile: AIAA/TIS

Descriptors: \*COMMERCIAL SPACECRAFT; \*LEASING; \*MULTIMISSION MODULAR SPACECRAFT; \*PAYLOADS; \*SPACE COMMERCIALIZATION; \*SPACE PLATFORMS; ATTITUDE CONTROL; EARTH ORBITS; NASA PROGRAMS; REMOTE SENSORS; SOLAR MAXIMUM MISSION

Subject Classification: 7515 .Launch Vehicles & Space Vehicles (1975-)

1326167 A84-46544

The economics of mapping with space data

DOYLE, F. J. (U.S. Geological Survey, Reston, VA)

ITC Journal (ISSN 0303-2434), no. 1, 1984, p. 1-9.

Publication Date: 1984

Language: English

Country of Origin: United States Country of Publication:

Netherlands

Document Type: JOURNAL ARTICLE

Most documents available from AIAA Technical Library

Journal Announcement: IAA8423

Some of the costs and benefits of space mapping programs are discussed. Consideration is given to four general areas where costs are incurred in space mapping programs: data acquisition; data processing and dissemination; ground control and field work; and cartography and printing. The data acquisition costs are shown to be the highest because they include the design and launch of new spacecraft and sensors, the cost of operating photographic mapping satellites in orbit and the costs of recovering data. Specific emphasis is given to the direct dollar costs incurred during several recent space mapping missions: Landsat 4, the Modular Payload Support Structure for the Large Format Camera (LFC), the Shuttle Pallet Satellite (SPS), Landsat 5, Ariane, Conestoga II, and Leasecraft. In order to illustrate how high costs are incurred, a sample space mapping system is considered which produced an annotated image map of the U.S. for 69 million dollars per square km. It is argued that such costs are acceptable because of the great advantages space mapping presents over conventional survey/mapping methods. (I.H.)

Source of Abstract/Subfile: AIAA/TIS

Descriptors: \*COST ANALYSIS; \*PHOTOMAPPING; \*SATELLITE-BORNE

INSTRUMENTS; \*SPACEBORNE PHOTOGRAPHY; \*THEMATIC MAPPING; DATA ACQUISITION; DATA PROCESSING; LANDSAT 4; PRINTING  
Subject Classification: 7543 .Earth Resources (1975-)

1298855 A84-27945

Leasecraft - An innovative space vehicle

DESKEVICH, J. (Fairchild Space Co., Germantown, MD)

IEEE Transactions on Aerospace and Electronic Systems (ISSN 0018-9251), vol. AES-20, Jan. 1984, p. 25-37.

Publication Date: Jan. 1984

Language: English

Country of Origin: United States Country of Publication: United States

Document Type: JOURNAL ARTICLE

Most documents available from AIAA Technical Library

Journal Announcement: IAA8411

The Leasecraft system has been developed by an American aerospace company with the objective to further the industrialization of space with its significant business potential. This system comprises a low orbit space platform, an operation control center, user accommodations, and services such as payload interfaces, documentation, and ground support equipment and procedures. Potential applications of Leasecraft considered are related to the processing of pharmaceuticals and materials, satellite-aided search and rescue, data collection, and support of NASA's astrophysics programs. The Leasecraft space vehicle will accommodate up to five modular power subsystems, including a communications and data handling module, a modular attitude control subsystem, a special function module, two alternative solar array assemblies, a tracking and data relay satellite system antenna assembly, a propulsion module, and optional primary and secondary payload modules. (G.R.)

Source of Abstract/Subfile: AIAA/TIS

Descriptors: \*COMMERCIAL SPACECRAFT; \*SPACE COMMERCIALIZATION; \*SPACE INDUSTRIALIZATION; \*SPACE PLATFORMS; \*SPACECRAFT DESIGN; COST EFFECTIVENESS; DATA MANAGEMENT; LEASING; ORBITAL SERVICING; SPACE PROCESSING; SPACECRAFT COMMUNICATION; SPACECRAFT MODULES

Subject Classification: 7515 .Launch Vehicles & Space Vehicles (1975-)

1284836 A84-22336

Remote manipulators in space

MATTHEWS, P. S.; HILL, B. R. (Spar Aerospace, Ltd., Remote Manipulator Systems Div., Toronto, Canada); WAGNER-BARTAK, C. G.

IN: Manufacturing in space; Proceedings of the Winter Annual Meeting, Boston, MA, November 13-18, 1983 (A84-22327 08-12). New York, American Society of Mechanical Engineers, 1983, p. 101-112.

Publication Date: 1983

Language: English

(cont. next page)

ORIGINAL PAGE IS  
OF POOR QUALITY

## DIALOG File 108: AEROSPACE - 62-86/ISS09

Country of Origin: Canada Country of Publication: United States

Document Type: CONFERENCE PAPER

Most documents available from AIAA Technical Library

Journal Announcement: IAAB408

The role of manipulators in space and the major design challenges of the current Remote Manipulator System (RMS) are treated. The RMS, operated by both man-in-the-loop and preprogrammed control, manipulates a maximum 30,000 kg payload, 18.3 m in length and 4.5 m in diameter. End point accuracy is in the order of + or - 5 cm and + or - 1 deg when automatically controlled and better than + or - 1-1/2 cm when operator controlled. RMS functions discussed include the future deployment of on-orbit, Shuttle tended platforms such as Eureka and Leasecraft, where robotic technology will exploit the constant microgravity environment for manufacturing processes. In the future, control systems will only be provided with tasks; manipulators will effect obstacle-avoiding, automatic interfacing of tools and spacecraft with fully sensate hands that include force and visual/proximity sensing. (C.M.)

Source of Abstract/Subfile: AIAA/TIS

Descriptors: +MANIPULATORS; +REMOTE MANIPULATOR SYSTEM; +ROBOTICS; +SPACE MANUFACTURING; +TELEOPERATORS; PHOTOGRAMMETRY; SPACE TRANSPORTATION SYSTEM; SYSTEMS ENGINEERING; TOOLS

Subject Classification: 7516 .Space Transportation (1975-)

1284835 A84-22335

**The Fairchild Leasecraft - A low orbit satellite manufacturing facility**

RAAB, B.; DESKOVITCH, J.; BRODSKY, M. T. (Fairchild Space Co., Germantown, MD)

IN: Manufacturing in space; Proceedings of the Winter Annual Meeting, Boston, MA, November 13-18, 1983 (A84-22327 08-12). New York, American Society of Mechanical Engineers, 1983, p. 87-99.

Publication Date: 1983

Language: English

Country of Origin: United States Country of Publication: United States

Document Type: CONFERENCE PAPER

Most documents available from AIAA Technical Library

Journal Announcement: IAAB408

While using the standard modules of the NASA Multi-Mission Modular Spacecraft, the Leasecraft extends the on-orbit service and module-exchange capability to all of the major subsystems of the spacecraft and to the payload as well. Besides this, a relatively large integral liquid propulsion system is included in order to enhance the spacecraft's mobility. The on-board inertial guidance and computer systems will be used by the propulsion system to effect orbit modification and the principal rendezvous maneuvers. It is pointed out that a multiplex command and data bus simplifies the accommodation of different payloads through a set of standard mechanical and electrical connectors and remote

interface units. As designed, the platform can provide as much as seven kilowatts of power for materials-processing or other uses in a high-power configuration. Also available is a low-power version for scientific and remote sensing missions. (C.R.)

Source of Abstract/Subfile: AIAA/TIS

Descriptors: +MULTIMISSION MODULAR SPACECRAFT; +SPACE COMMERCIALIZATION; +SPACE MANUFACTURING; +SPACE TRANSPORTATION SYSTEM; SATELLITE ANTENNAS; SPACE PLATFORMS; SPACE SHUTTLE PAYLOADS; SPACECRAFT CONFIGURATIONS; SPACECRAFT MODULES

Subject Classification: 7512 .Astronautics--General (1975-)

1274273 A84-11773

**The Fairchild Leasecraft system - A commercially-operated platform for science and business in space**

RAAB, B. (Fairchild Space Co., Germantown, MD)

International Astronautical Federation, International Astronautical Congress, 34th, Budapest, Hungary, Oct. 10-15, 1983, 10 p.

Publication Date: Oct. 1983

Report No.: IAF PAPER 83-232

Language: English

Country of Origin: United States Country of Publication: International Organization

Document Type: PREPRINT

Most documents available from AIAA Technical Library

Journal Announcement: IAAB402

Design features and mission profiles for the Leasecraft free-flying platforms are described. The Leasecraft would use multimission modular spacecraft (MMS) configured for launch by the Shuttle, transfer to 28.5 deg polar sunsynchronous inclination orbits, and return for later retrieval with the RMS arm, changeout and replacement of the payload, and return to the sunsynchronous orbit. The Leasecraft would have two optional solar power panels, an attitude control subsystem, a special function module, and a TDRSS antenna, as well as a propulsion subsystem that would also be refueled during Orbiter rendezvous. Payloads would be categorized as primary or secondary, with the former claiming priority on the spacecraft attitude, mission modes, and revisit intervals. An example of a primary mission would be the Advanced X-ray Astrophysics Facility, while secondary payloads could include materials processing experiments and search and rescue transponders. Primary services are expected to cost \$2-4 million/month, while secondary services run \$0.5-1 million/month. (M.S.K.)

Source of Abstract/Subfile: AIAA/TIS

Descriptors: +SPACE PLATFORMS; +SPACE SHUTTLE PAYLOADS; +SPACE TRANSPORTATION SYSTEM; DATA ACQUISITION; SPACE PROCESSING; SPACECRAFT CONFIGURATIONS; SPACECRAFT MODULES; TOR SATELLITES

Subject Classification: 7515 .Launch Vehicles & Space Vehicles (1975-)

**"Page missing from available version"**

*Pgs. 79 - 83*

DIALOG File 108: AEROSPACE - 62-86/ISS09

1435935 A86-24128

NASA centers will stimulate industry R & D  
DOOLING, D. (Essex Corp., Huntsville, AL)  
Commercial Space (ISSN 8756-4831), vol. 1, Fall 1985, p.  
95-98.

Publication Date: 1985

Language: English

Country of Origin: United States Country of Publication:  
United States

Document Type: JOURNAL ARTICLE

Most documents available from AIAA Technical Library

Journal Announcement: IAA8609

Four prototype centers supported by NASA in order to stimulate research and development, and encourage individual investment in space are described. The crystallography program of the Center for Macromolecular Crystallization is examined; the center will grow the crystals in space and analyze the usefulness of the products. The benefits and problems of these protein experiments are investigated. The Consortium for Materials Development is to study the applications of physical chemistry and material transport through fluids in space. The processes by which metals, alloys, ceramics, and glasses are formed will be analyzed by the Center for Space Processing of Engineering Materials in order to improve production on earth.

The interpretation and commercialization of Landsat data is conducted at the Space Remote Sensing Center. The production of materials which will be easily commercialized, such as piezoelectric transducers and glass microspheres, is the objective of the Multi-Phase Materials Center. (I.F.)

Source of Abstract/Subfile: AIAA/TIS

Descriptors: \*REMOTE SENSING; \*RESEARCH AND DEVELOPMENT;  
\*SPACE COMMERCIALIZATION; \*SPACE PROCESSING; \*SPACEBORNE  
EXPERIMENTS; CONTRACTS; CRYSTAL GROWTH; LANDSAT SATELLITES;  
PROTEINS; SATELLITE IMAGERY

Subject Classification: 7581 Administration & Management  
(1975-)

1435924 A86-24117

Space Industries is making plans with NASA for a space  
facility

FAGET, M.

Commercial Space (ISSN 8756-4831), vol. 1, Fall 1985, p. 40,  
41, 44.

Publication Date: 1985

Language: English

Country of Origin: United States Country of Publication:  
United States

Document Type: JOURNAL ARTICLE

Most documents available from AIAA Technical Library

Journal Announcement: IAA8609

The development of a privately funded space facility as the base of operation for commercial space projects is examined. The 35 foot long and 14.5 foot wide facility is to contain automatic material processing equipment, which will be periodically serviced by the Shuttle crew. The benefits of NASA's deferred payment agreement, which will allow the

facility to be established with no payment required until revenue is generated by the project, are described. The building and assembly of the industrial space facility, and the designing of the docking module are analyzed. Potential projects for the facility include: (1) the development of organic films that use light to carry information, (2) the manufacturing of semiconductor materials, and (3) a biological space medicines processing system. (I.F.)

Source of Abstract/Subfile: AIAA/TIS

Descriptors: \*SPACE COMMERCIALIZATION; \*SPACE INDUSTRIALIZA-  
TION; \*SPACE PROCESSING; \*SPACECRAFT DESIGN; MEDICINE; ORGANIC  
MATERIALS; SEMICONDUCTORS (MATERIALS)

Subject Classification: 7518 Spacecraft Design, Testing &  
Performance (1975-)

1435914 A86-24107

What's the payoff? Pluses and minuses of space processing (   
space processing)

EGAN, J. J. (Coopers and Lybrand, Space Consulting Div.,  
Washington, DC)Commercial Space (ISSN 8756-4831), vol. 1, Summer 1985, p.  
62, 63, 65, 66.

Publication Date: 1985

Language: English

Country of Origin: United States Country of Publication:  
United States

Document Type: JOURNAL ARTICLE

Most documents available from AIAA Technical Library

Journal Announcement: IAA8609

The economic factors governing the development of space processing techniques are discussed. Emphasis is given to the potential benefits of new processes for zero-g production of pharmaceuticals, protein crystals, advanced metals, and semiconductor materials. It is shown that a vigorous joint effort by government and industry to lower the costs of launching and maintaining space-based materials processing platforms is required before the economic benefits of space processing can be accrued. A pie graph showing the costs of space-processed semiconductor chips is provided. (I.H.)

Source of Abstract/Subfile: AIAA/TIS

Descriptors: \*ECONOMIC ANALYSIS; \*SPACE COMMERCIALIZATION;  
\*SPACE INDUSTRIALIZATION; \*SPACE PROCESSING; COSTS; CRYSTAL  
GROWTH; MATERIALS SCIENCE; PHARMACOLOGY

Subject Classification: 7583 Economics & Cost Analysis  
(1975-)

1435909 A86-24102

Washington broadens its efforts to aid small business

MANN, P.

Commercial Space (ISSN 8756-4831), vol. 1, Summer 1985, p.  
21, 24, 25.

Publication Date: 1985

Language: English

(cont. next page)

## DIALOG File 108: AEROSPACE - 82-86/ISS09

Country of Origin: United States Country of Publication: United States

Document Type: JOURNAL ARTICLE

Most documents available from AIAA Technical Library

Journal Announcement: IAA8609

Efforts by NASA to develop interest in the small business community for commercial space ventures are discussed. Activities undertaken by NASA's Office of Commercial Programs to facilitate Joint Endeavor Agreements (JEAs) between small business and NASA are described in detail. Emphasis is given to the need for a broad array of potential investors in capital-intensive space R&D programs, including: electronic materials research; pharmaceuticals processing; remote sensing; and satellite communications. A list of U.S. government centers for space business information is provided. (I.H.)

Source of Abstract/Subfile: AIAA/TIS

Descriptors: +GOVERNMENT/INDUSTRY RELATIONS; +RESEARCH AND DEVELOPMENT; +SPACE COMMERCIALIZATION; +TECHNOLOGY UTILIZATION; +NASA PROGRAMS; UNITED STATES

Subject Classification: 7581 Administration & Management (1975-)

1435908 A86-24101

Orbital processing promises investors immediate financial rewards

DOOLING, D.

Commercial Space (ISSN 8756-4831), vol. 1, Summer 1985, p. 14-20.

Publication Date: 1985

Language: English

Country of Origin: United States Country of Publication: United States

Document Type: JOURNAL ARTICLE

Most documents available from AIAA Technical Library

Journal Announcement: IAA8609

A general description of the Materials Processing in Space (MPS) program at NASA/Marshall is given. The three main components of the MPS program are outlined, including: R&D to improve terrestrial processes; R&D leading to space production for later terrestrial sales; and technology transfer. The development of second generation processing facilities for protein crystal growth, inorganic crystal growth, and gallium arsenide crystal growth on board Shuttle is discussed in detail. Color photographs of space-grown mercury iodide and triglycine sulfate crystals are provided. (I.H.)

Source of Abstract/Subfile: AIAA/TIS

Descriptors: +MATERIALS SCIENCE; +SPACE COMMERCIALIZATION; +SPACE INDUSTRIALIZATION; +SPACE PROCESSING; CRYSTAL GROWTH; REDUCED GRAVITY; RESEARCH AND DEVELOPMENT; SPACE SHUTTLE PAYLOADS; SPACELAB PAYLOADS

Subject Classification: 7512 Astronautics--General (1975-)

1433057 A86-22267

Satellite leasing - Cheap access to space

MAEHL, R. (RCA, Astro-Electronics Div., Princeton, NJ)

Space (ISSN 0267-954X), vol. 1, Dec. 1985-Feb. 1986, p. 10, 11, 17.

Publication Date: Feb. 1986

Language: English

Country of Origin: United States Country of Publication: United Kingdom

Document Type: JOURNAL ARTICLE

Most documents available from AIAA Technical Library

Journal Announcement: IAA8608

The role of satellite leasing arrangements in marketing commercial ventures in space is considered. The most recent examples of leased space platforms are described, including Leasat; ESA's EURECA; Omnistar; and Leascraft. It is shown that because of NASA Shuttle pricing policies, leasing room for commercial payloads on board space platforms will become an increasingly attractive way of financing space ventures in which capital investments are often at risk. The development of the first large-scale commercial space platform for the Electrophoresis in Space (EOS) program is also discussed. (I.H.)

Source of Abstract/Subfile: AIAA/TIS

Descriptors: +LEASING; +SPACE COMMERCIALIZATION; +SPACE PLATFORMS; +SPACE PROCESSING; MARKETING; SPACE TRANSPORTATION SYSTEM

Subject Classification: 7581 Administration & Management (1975-)

1433040 A86-22250

The challenge of the US Space Station

BEGGS, J. M. (NASA, Washington, DC)

National Aeronautics and Space Administration, Washington, D.C.

Corp. Source Code: NC452981

Space Policy (ISSN 0265-9646), vol. 1, Feb. 1985, p. 85-90.

Publication Date: Feb. 1985

Language: English

Country of Origin: United States Country of Publication: United Kingdom

Document Type: JOURNAL ARTICLE

Most documents available from AIAA Technical Library

Journal Announcement: IAA8608

The U.S. Space Station program is described. The objectives of the present national space policy are reviewed. International involvement and commercial use of space are the two strategies involved in the development of the Space Station. The Space Station is to be a multifunctional, modular, permanent facility with manned and unmanned platforms. The functions of the Space Station for space research projects, such as material processing and electrophoresis, are examined. The infrastructure required for commercialization of space is analyzed. NASA's space policy (cont. next page)

ORIGINAL PAGE IS  
OF POOR QUALITY

## DIALOG File 108: AEROSPACE - 82-86/ISS09

aimed at stimulating space commerce is discussed. NASA's plans to reduce the financial, institutional, and technical risks of space research are studied. (I.F.)

Source of Abstract/Subfile: AIAA/TIS

Descriptors: \*SPACE COMMERCIALIZATION; \*SPACE INDUSTRIALIZATION; \*SPACE STATIONS; INTERNATIONAL COOPERATION; POLICIES; UNITED STATES

Subject Classification: 7512 .Astronautics--General (1975-)

1432676 A86-21886

**Economic considerations of space manufacturing**

JOHNSTON, W. A., JR.; MONTGOMERY, B. G. (Fairchild Space Co., Germantown, MD)

IN: EASCON '84; Proceedings of the Seventeenth Annual Electronics and Aerospace Conference, Washington, DC, September 10-12, 1984 (A86-21876 08-32). New York, Institute of Electrical and Electronics Engineers, 1984, p. 181-185.

Publication Date: 1984

Language: English

Country of Origin: United States Country of Publication: United States

Document Type: CONFERENCE PAPER

Most documents available from AIAA Technical Library

Journal Announcement: IAA8608

Materials processing in space (MPS) offers an opportunity to produce dramatic new products in pharmaceuticals, electronics, and metals. But the cost of access to space forces prospective manufacturers to select products whose market value is exceptionally high. This paper addresses the factors influencing the costs of transporting and operating factories in space and offers approaches for minimizing the effect of these costs on the finished product. In particular, the trade-off between operating entirely on the shuttle versus setting up on a free-flying platform is explored, with examples given for hypothetical pharmaceutical and crystal manufacturing processes. (Author)

Source of Abstract/Subfile: AIAA/TIS

Descriptors: \*ECONOMIC FACTORS; \*MATERIALS SCIENCE; \*SPACE COMMERCIALIZATION; \*SPACE MANUFACTURING; \*SPACE PROCESSING; COST ANALYSIS; CRYSTAL GROWTH; MASS RATIOS; PHARMACOLOGY; SPACE TRANSPORTATION

Subject Classification: 7583 .Economics & Cost Analysis (1975-)

1427140 A86-18376

**A fortune in orbit**

PARKER, I.

Space (ISSN 0267-954X), vol. 1, Sept. 1985, p. 64-67.

Publication Date: Sep. 1985

Language: English

Country of Origin: United Kingdom Country of Publication: United Kingdom

Document Type: JOURNAL ARTICLE

Most documents available from AIAA Technical Library

Journal Announcement: IAA8606

The commercial value of material processing in space is discussed. In order for material processing to be profitable the items produced in space must not be price sensitive. The potential processing costs to be incurred by companies which will manufacture in space are examined. The application of space processing to computer chips, electrophoresis, and metal manufacturing are described. (I.F.)

Source of Abstract/Subfile: AIAA/TIS

Descriptors: \*SPACE COMMERCIALIZATION; \*SPACE PROCESSING; AIRBORNE/SPACEBORNE COMPUTERS; COSTS; ELECTROPHORESIS

Subject Classification: 7512 .Astronautics--General (1975-)

1425058 A86-17320

**Human roles in future space systems**

WOLBERS, H. L. (McDonnell Douglas Astronautics Co., Huntington Beach, CA)

IN: Permanent presence - Making it work; Proceedings of the Twenty-second Goddard Memorial Symposium, Greenbelt, MD, March 15, 16, 1984 (A86-17315 05-12). San Diego, CA, Univelt, Inc., 1985, p. 57-69.

Publication Date: 1985 6 Refs.

Report No.: AAS PAPER 84-117

Language: English

Country of Origin: United States Country of Publication: United States

Document Type: CONFERENCE PAPER

Most documents available from AIAA Technical Library

Journal Announcement: IAA8605

U.S. and Soviet space programs to date have graphically demonstrated the value of humans working in space. The point at issue is to determine where, along the continuum from direct manual intervention to completely automated operations, the mission requirements of future space programs can best be met. The criteria of performance, cost, and risk (mission success probability) are suggested as the principal factors by which program or project managers and systems engineers should select the most effective approach to meeting specific mission objectives. Examples of the application of these criteria are presented. (Author)

Source of Abstract/Subfile: AIAA/TIS

Descriptors: \*ASTRONAUT PERFORMANCE; \*ORBITAL SPACE STATIONS; \*SPACECREWS; COSTS; ELECTROPHORESIS; ORBITAL ASSEMBLY; RISK SPACE COMMERCIALIZATION; SPACE PLATFORMS; SPACE PROCESSING; SPACE TRANSPORTATION SYSTEM 4 FLIGHT

Subject Classification: 7554 .Man/System Technology & Life Support (1975-)

1425054 A86-17316

**Electrophoresis operations in space for pharmaceutical processing**

RICHMAN, D. W. (McDonnell Douglas Corp., St. Louis, MO)

IN: Permanent presence - Making it work; Proceedings of the Twenty-second Goddard Memorial Symposium, Greenbelt, MD, March

(cont. next page)

## DIALOG File 108: AEROSPACE - 62-86/ISS09

15, 16, 1984 (A86-17315 05-12). San Diego, CA, Univelt, Inc., 1985, p. 11-16.

Publication Date: 1985  
Report No.: AAS PAPER 84-107  
Language: English

Country of Origin: United States Country of Publication: United States

Document Type: CONFERENCE PAPER  
Most documents available from AIAA Technical Library  
Journal Announcement: IAA8605

Electrophoresis experiments on board Shuttle are reviewed, with emphasis given to the pharmaceutical processing applications of electrophoresis in zero-gravity. In its first demonstration on the fourth flight of the Shuttle in June 1982, a protein sample was separated that contained five hundred times more protein than would have been possible on earth. The chamber used for the separation has been flown on five additional Shuttle missions to further demonstrate the advantages of space-based pharmaceutical processing. Development of a scaled-up Production Prototype electrophoresis chamber for the Shuttle Payload Bay is described in detail. Attention is also given to the long range goals of NASA's Electrophoresis Operations in Space (EOS) program which is to install a production unit on board an earth-orbiting facility, such as Space Station, by the year 1989. (I.I.)

Source of Abstract/Subfile: AIAA/TIS  
Descriptors: +ELECTROPHORESIS; +PHARMACOLOGY; +PROTEINS; +SPACE COMMERCIALIZATION; +SPACE PROCESSING; SEPARATION; SPACE SHUTTLE PAYLOADS; SPACE STATIONS; SPACE TRANSPORTATION SYSTEM 4 FLIGHT

Subject Classification: 7512 .Astronautics--General (1975-)

1425053 A86-17315

Permanent presence - Making it work; Proceedings of the Twenty-second Goddard Memorial Symposium, Greenbelt, MD, March 15, 16, 1984 (role of future Space Station)

BEKEY, I., ED. (NASA, Washington, DC)  
National Aeronautics and Space Administration, Washington, D.C.

Corp. Source Code: NC452981  
Symposium sponsored by AAS. San Diego, CA, Univelt, Inc. (Science and Technology Series, Volume 60), 1985, 188 p. For individual items see A86-17316 to A86-17324.

Publication Date: 1985  
Language: English

Country of Origin: United States Country of Publication: United States

Document Type: CONFERENCE PROCEEDINGS  
Journal Announcement: IAA8605

Among the topics discussed are: electrophoresis operations in space for pharmaceutical processing; Space Station program operations; and Space Station platform configurations. Consideration is also given to: the human role in future space systems; EVA operations; spherical shell applications; and a container material for alloy processing in near-zero gravity.

Among additional topics discussed are: Space Station platform thermal control; environmental control and life support for an evolving capability manned Space Station; and the commercial prospects of the Space Station. (I.H.)

Source of Abstract/Subfile: AIAA/TIS

Descriptors: +CONFERENCES; +ORBITAL SPACE STATIONS; \*SPACE STATIONS; ELECTROPHORESIS; ENVIRONMENTAL CONTROL; EXTRAVEHICULAR ACTIVITY; METALLURGY; REUSABLE SPACECRAFT; SPACE COMMERCIALIZATION; SPACE PLATFORMS; SPACE PROCESSING; SPACEBORNE EXPERIMENTS; SPACECRAFT POWER SUPPLIES; TEMPERATURE CONTROL

Subject Classification: 7512 .Astronautics--General (1975-)

1425050 A86-17312

The potential of materials processing using the space environment

ROSE, J. T.; FITZPATRICK, T. D. (McDonnell Douglas Astronautics Co., St. Louis, MO)

IN: Space stations and space platforms - Concepts, design, infrastructure and uses (A86-17301 05-12). New York, American Institute of Aeronautics and Astronautics, 1985, p. 167-200.

Publication Date: 1985. 11 Refs.

Language: English

Country of Origin: United States Country of Publication: United States

Document Type: ANALYTIC OF COLLECTED WORK  
Most documents available from AIAA Technical Library  
Journal Announcement: IAA8605

The scientific, economic, structural, and political problems and advantages of material processing in space (MPS) are discussed. The microgravity environment provides the setting for new developments in biological materials, metal alloys and composites, and semiconductor crystals and glasses. The benefits of the Space Shuttle for MPS are described. A review of the history of MPS in the U.S. and abroad is presented. The electrophoresis operations in space (EOS) project is examined; the problems encountered with static electrophoresis and continuous flow electrophoresis on earth, and the increases in concentration, flow rate, and purity provided by EOS are studied. The economic and commercial advantages possible by conducting EOS and MPS within the Space Station are investigated. (I.F.)

Source of Abstract/Subfile: AIAA/TIS

Descriptors: +ELECTROPHORESIS; +SPACE COMMERCIALIZATION; \*SPACE PROCESSING; CONVECTION CURRENTS; HISTORIES; PHARMACOLOGY; SPACE TRANSPORTATION SYSTEM

Subject Classification: 7512 .Astronautics--General (1975-)

1423070 N86-13352

EURECA: An introduction to Europe's free-flying retrievable carrier

LONGDON, N., comp.

European Space Agency, Paris (France).

(cont. next page)

## DIALOG File 108: AEROSPACE - 62-86/ISS09

Corp. Source Code: E6854803  
 Publication Date: May 1985 21P.  
 Announcements: Original contains color illustrations  
 Report No.: ESA-BR-30; ISSN-0250-1589  
 Language: English  
 Country of Origin: France Country of Publication:  
 International Organization  
 Document Type: REPORT  
 Most documents available from AIAA Technical Library  
 Other Availability: NTIS HC A02/MF A01  
 Journal Announcement: STAR8604

The European Retrievable Carrier (EURECA) is a reusable platform launched by the Shuttle, released in a free flying mode for 6 months or more, and then retrieved by the Shuttle Orbiter and returned to Earth. Payload capacity is up to 1000 kg. The first EURECA payload is primarily dedicated to material and life sciences which benefit from the microgravity environment. The versatility of the system is demonstrated by the fact that a quarter of the payload weight is taken up by space science and technological experiments. The EURECA provides an excellent test bed to demonstrate in-flight technologies such as direct data relay from low Earth orbits via geostationary satellites to a central operations center, rendezvous and docking, and in-orbit servicing. Earth observation possibilities, and commercial applications (new materials, crystal growth, proteins, and pharmaceutical products) are numerous. (Author (ESA))

Source of Abstract/Subfile: ESA  
 Descriptors: \*EURECA (ESA); \*EUROPEAN SPACE PROGRAMS; \*PAYLOAD RETRIEVAL (STS); \*SPACEBORNE EXPERIMENTS; \*SPACECRAFT DESIGN; EARTH OBSERVATIONS (FROM SPACE); EQUIPMENT SPECIFICATIONS; SPACE COMMERCIALIZATION; SPACE MANUFACTURING; SPACE PROCESSING; SPACE SHUTTLES  
 Subject Classification: 7516 .Space Transportation (1975-)

1422712 A86-15902

**Commercialization of space - A comprehensive approach**

MAEHL, R. C. (RCA, Astro-Electronics Div., Princeton, NJ)  
 IAF, International Astronautical Congress, 36th, Stockholm, Sweden, Oct. 7-12, 1985. 6 p.  
 Publication Date: Oct. 1985  
 Report No.: IAF PAPER 85-431  
 Language: English  
 Country of Origin: United States Country of Publication:  
 International Organization  
 Document Type: PREPRINT  
 Most documents available from AIAA Technical Library  
 Journal Announcement: IAA8604

The role of the government and private industries in the commercialization of space is investigated. The government needs to provide funding, stimulate research and development, and establish regulations, and industries need to develop areas which will provide profitable investments. The three phases of the evolution of space activities, which are high tech R and D, the development of infrastructure, and the establishment of the industry, are described. The relationship

between NASA's policies, the joint endeavor agreement, and the stages of the evolution of space activities is analyzed; a balance between investment and profit needs to be established.

Two examples of existing space commercialization, the American commercial Landsat venture, and developments in the low altitude commercial platforms for material processing and scientific missions are presented. (I.F.)

Source of Abstract/Subfile: AIAA/TIS  
 Descriptors: \*GOVERNMENT/INDUSTRY RELATIONS; \*RESEARCH AND DEVELOPMENT; \*SPACE COMMERCIALIZATION; LANDSAT SATELLITES; SPACE INDUSTRIALIZATION; SPACE MANUFACTURING  
 Subject Classification: 7581 .Administration & Management (1975-)

1422711 A86-15901

**Space commercialization in the United States - A status report**

LOGSDON, J. M. (George Washington University, Washington, DC)

IAF, International Astronautical Congress, 36th, Stockholm, Sweden, Oct. 7-12, 1985. 16 p.

Publication Date: Oct. 1985 16 Refs.

Report No.: IAF PAPER 85-430

Language: English

Country of Origin: United States Country of Publication:  
 International Organization  
 Document Type: PREPRINT  
 Most documents available from AIAA Technical Library  
 Journal Announcement: IAA8604

The problems encountered and areas of developments in space commercialization in the U.S. are analyzed. Developments such as, reductions in projected payoffs from space commercialization, the incurred losses and increased cost to a business for space activities, the slow development of material processing in space, and the limited areas for investment, which have led to reduced interest and investment in space commercialization, are discussed. Emphasis must be placed on the process of developing the research base and infrastructure required for commercialization of space. The future use of the Space Shuttle and its pricing are investigated. The incorporation of the proper requirements into a Space Station is studied. The establishment of an Office of Commercial Programs to direct and control NASA's space commercialization policies is discussed. (I.F.)

Source of Abstract/Subfile: AIAA/TIS  
 Descriptors: \*ECONOMIC ANALYSIS; \*SPACE COMMERCIALIZATION; \*UNITED STATES; NASA SPACE PROGRAMS; SPACE PROCESSING; SPACE STATIONS; SPACE TRANSPORTATION SYSTEM  
 Subject Classification: 7581 .Administration & Management (1975-)

ORIGINAL PAGE IS  
OF POOR QUALITY



## DIALOG File 108: AEROSPACE - 62-88/ISS09

1422709 A86-15899

## Commercialization of space activities

GILLAM, J. T., IV

IAF, International Astronautical Congress, 36th, Stockholm, Sweden, Oct. 7-12, 1985. 12 p.

Publication Date: Oct. 1985 6 Refs.

Report No.: IAF PAPER 85-428

Language: English

Country of Origin: International Organization Country of

Publication: International Organization

Document Type: PREPRINT

Most documents available from AIAA Technical Library

Journal Announcement: IAA8604

Areas for private investment and the stimulation of private involvement in space activities are studied. Commercial uses for space include: (1) material processing, (2) space-based communication links, (3) data and imagery from earth and navigation and position location services, (4) in-space infrastructure services, and (5) space transportation. All these potential areas of investment are described and examples are presented. NASA's principles which encourage and stimulate free enterprise in space are discussed. The implementation of these principles in order to reduce technical, financial and institutional risks is examined. The role of the Office of Commercial Programs in commercializing space is analyzed. The NASA program which provides assistance in the utilization of aerospace technology is described. (I.F.)

Source of Abstract/Subfile: AIAA/TIS

Descriptors: \*NASA PROGRAMS; \*POLICIES; \*SPACE COMMERCIALIZATION; COMMUNICATION SATELLITES; SPACE INDUSTRIALIZATION; SPACE PROCESSING; SPACE TRANSPORTATION SYSTEM; TECHNOLOGY UTILIZATION

Subject Classification: 7581 Administration & Management (1975-)

1420250 N86-12243

## Marketing the use of the space environment for the processing of biological and pharmaceutical materials

Final Report

ECON, Inc., Alexandria, Va.

Corp. Source Code: ED782198

Publication Date: Apr. 1984 162P.

Report No.: NASA-CR-176334; NAS 1.26:176334; ECON-81-110

Contract No.: NASW-3339

Language: English

Country of Origin: United States Country of Publication: United States

Document Type: REPORT

Most documents available from AIAA Technical Library

Other Availability: NTIS HC AOB/MF AO1

Journal Announcement: STAR8603

The perceptions of U.S. biotechnology and pharmaceutical companies concerning the potential use of the space environment for the processing of biological substances was examined. Physical phenomena that may be important in space-base processing of biological materials are identified

and discussed in the context of past and current experiment programs. The capabilities of NASA to support future research and development, and to engage in cooperative risk sharing programs with industry are discussed. Meetings were held with several biotechnology and pharmaceutical companies to provide data for an analysis of the attitudes and perceptions of these industries toward the use of the space environment. Recommendations are made for actions that might be taken by NASA to facilitate the marketing of the use of the space environment, and in particular the Space Shuttle, to the biotechnology and pharmaceutical industries. (Author)

Descriptors: \*BIOTECHNOLOGY; \*PHARMACOLOGY; \*RESEARCH AND DEVELOPMENT; \*SPACE MANUFACTURING; AEROSPACE ENVIRONMENTS; DRUGS; MEDICAL SCIENCE; SPACE SHUTTLES; TECHNOLOGY UTILIZATION

Subject Classification: 7512 Astronautics--General (1975-)

COSATI Code: 22A Astronautics

1416623 A86-11954

## Space Station redesigned for larger structural area

COVAULT, C.

Aviation Week and Space Technology (ISSN 0005-2175), vol. 123, Oct. 14, 1985, p. 16-18.

Publication Date: Oct. 1985

Language: English

Country of Origin: United States Country of Publication: United States

Document Type: JOURNAL ARTICLE

Most documents available from AIAA Technical Library

Journal Announcement: IAA8602

The present article is concerned with a redesign of the U.S. Space Station by NASA. The redesign has the objective to provide a better zero-gravity platform for materials processing and to obtain more structure on which to mount experiments, telescopes, and upper-stage hardware. Instead of a long, tall station, the redesign will feature a wide, boxlike permanently manned structure. The changes were made in response to the concerns of science and commercial users, whose support is needed if the Space Station project is to succeed. Attention is given to the new U.S. Space Station dual keel design, safety considerations, an evaluation of development versus operating costs, station operations concepts, and operations management. (G.R.)

Source of Abstract/Subfile: AIAA/TIS

Descriptors: \*DESIGN ANALYSIS; \*NASA PROGRAMS; \*ORBITAL SPACE STATIONS; \*SPACE STATIONS; \*SPACECRAFT DESIGN; COST ANALYSIS; ORBITAL SERVICING; SPACE MANUFACTURING; SPACE PLATFORMS

Subject Classification: 7518 Spacecraft Design, Testing & Performance (1975-)

## DIALOG File 108: AEROSPACE - 62-86/ISS09

1416478 A86-11809

**Utilization of Space Shuttle External Tank materials by melting and powder metallurgy**

CHERN, T. S. (California, University, Scripps Institution of Oceanography, La Jolla)

Scripps Institution of Oceanography, La Jolla, Calif.

Corp. Source Code: SE716697

Acta Astronautica (ISSN 0094-5765), vol. 12, Sept. 1985, p. 693-698.

Publication Date: Sep. 1985 6 Refs.

Contract No.: NAS8-35037

Language: English

Country of Origin: United States Country of Publication: United Kingdom

Document Type: JOURNAL ARTICLE

Most documents available from AIAA Technical Library

Journal Announcement: IAA8602

The Crucible Melt Extraction Process was demonstrated to convert scraps of aluminum alloy 2219, used in the Space Shuttle External Tank, into fibers. The cast fibers were then consolidated by cold welding. The X-ray diffraction test of the cast fibers was done to examine the crystallinity and oxide content of the fibers. The compressive stress-strain behavior of the consolidated materials was also examined. Two conceptual schemes which would adapt the as-developed Crucible Melt Extraction Process to the microgravity condition in space were finally proposed. (Author)

Source of Abstract/Subfile: AIAA/TIS

Descriptors: \*EXTERNAL TANKS; \*METAL FIBERS; \*POWDER METALLURGY; \*SPACE MANUFACTURING; \*SPACE SHUTTLES; \*SPACECRAFT CONSTRUCTION MATERIALS; FIBER COMPOSITES; MELTING; REUSE; SCRAP; STRESS-STRAIN RELATIONSHIPS; X RAY DIFFRACTION

Subject Classification: 7512 Astronautics--General (1975-)

1415734 N86-11068

**Space sciences: Perspectives of commercial utilization for the German industry**

WELTRAUMFORSCHUNG: PERSPEKTIVEN DER KOMMERZIELLEN NUTZUNG FUER DIE DEUTSCHE INDUSTRIE

JORDAN, H. L.

Bundesministerium fuer Forschung und Technologie, Bonn (West Germany).

Corp. Source Code: B4157221

In its Space Utilization p 2-16 (SEE N86-11067 01-81)

Publication Date: Jan. 1985

Presentation Note: Presented at BDI Ausschuss fuer Forsch.-u. Wissenschaftspolitik, Bonn, 19 Oct. 1984

Language: German

Country of Origin: Germany, Federal Republic of Country of Publication: Germany, Federal Republic of

Document Type: CONFERENCE PAPER

Most documents available from AIAA Technical Library

Other Availability: NTIS HC A04/MF A01

Journal Announcement: STAR8601

Space sciences and their possible utilization by industry are presented. The development of astronautics and

applications in observation techniques, communication, and navigation are reviewed. Utilization of reduced gravitational force effects: diffusion phenomena, crystal growth, production process for metals and composite materials, biochemistry, biotechnology, and biosciences are considered. (Author (ESA))

Source of Abstract/Subfile: ESA

Descriptors: \*AEROSPACE INDUSTRY; \*AEROSPACE SCIENCES; \*REDUCED GRAVITY; \*SPACE COMMERCIALIZATION; \*SPACE INDUSTRIALIZATION; BIOCHEMISTRY; BIOTECHNOLOGY; COMMUNICATION COMPOSITE MATERIALS; CRYSTAL GROWTH; EARTH OBSERVATIONS (FROM SPACE); SPACE NAVIGATION; SPACE PROCESSING

Subject Classification: 7581 Administration &amp; Management (1975-)

1414832 N86-10166

**Development of materials processing systems for use in space on low-g simulation devices**

ALDRICH, B. R.; WHITT, W. D.

National Aeronautics and Space Administration, Marshall Space Flight Center, Huntsville, Ala.

Corp. Source Code: ND736801

In NASA, Washington Microgravity Sci. and Appl. Program p 191 (SEE N86-10053 01-12)

Publication Date: May 1985

Language: English

Country of Origin: United States Country of Publication: United States

Document Type: REPORT

Most documents available from AIAA Technical Library

Other Availability: NTIS HC A10/MF A01

Journal Announcement: STAR8601

Advanced furnace systems are being developed for use in space. Systems are being tested for current experiment applications and modified for future experiment requirements. Future projects are: (1) fabrication and testing of the Advanced Automated Directional Solidification Furnace (AASDF) flight hardware; (2) development of a Heat Pipe Furnace (HPF) for use in space. Heat pipes will be tested for space flight qualification in conjunction with the furnace development. The HPF design will be based on the AASDF development and will be of modular design including capabilities of operating with or without heat pipes; and (3) the AASDF furnace will be modified and tested to operate at temperatures up to 1700 C in the heated cavity. This will be accomplished by developing a new hot end heating module and insulation package for the existing AASDF. Refurbishment of the Drop Tower Furnace (DTF) is under way. The DTF can operate at temperatures up to 1700 C. The sample size will be approximately 3/8 in. dia. x 5/8 in. long.

Design improvements for the General Purpose Rocket Furnace (GPRF) for use in the Material Experiment Assembly (MEA) are to be accomplished. (F.M.R.)

Source of Abstract/Subfile: NASA STIF

Descriptors: \*CAVITIES; \*DROP TOWERS; \*FURNACES; \*HEAT PIPES; \*MATERIALS HANDLING; \*REDUCED GRAVITY; \*SPACE MANUFACTURING

(cont. next page)

## DIALOG File 108: AEROSPACE - 62-88/ISS09

## EXPERIMENT DESIGN; GRAVITATION; SIMULATION

Subject Classification: 7512 .Astronautics--General (1975-)  
COSATI Code: 22A .Astronautics

1414092 A86-10567

**Will Columbus find enough users?**

JAQUES, R.

Interavia (ISSN. 0020-5168), vol. 40, Sept. 1985, p. 986, 987.

Publication Date: Sep. 1985

Language: English

Country of Origin: Switzerland Country of Publication: Switzerland

Document Type: JOURNAL ARTICLE

Most documents available from AIAA Technical Library

Journal Announcement: IAA8601

Current plans for the ESA Columbus Space Station (SS) co-orbiter are reviewed. A manned laboratory pressure module is intended to be attached to the SS to share power and living quarters. A Resource Module will be added 10 yr later and permit autonomy in co-orbit. The configuration would be accompanied by free-flying platforms, either co-orbiting or polar-orbiting, and a service vehicle. Initiatives are under way to generate commercial and scientific participation in the Columbus project by providing access to low-g laboratories and documentation, and by developing expert systems to assist payload users. Materials science and pharmaceuticals experiments are receiving the greatest industrial attention at present. It is not yet known whether the ownership of the SS will be in the form of a condominium or a commune. (M.S.K.)

Source of Abstract/Subfile: AIAA/TIS

Descriptors: \*EUROPEAN SPACE AGENCY; \*INTERNATIONAL RELATIONS; \*ORBITAL WORKSHOPS; \*SPACE LABORATORIES; CRYSTAL GROWTH; ITALIAN SPACE PROGRAM; SPACE MANUFACTURING

Subject Classification: 7518 .Spacecraft Design, Testing & Performance (1975-)

1411820 A85-49438

**Scientific foundations of space manufacturing (Book)**

AVDUEVSKII, V. S.; GRISHIN, S. D.; LESKOV, L. V.; POLEZHAEV, V. I.; SAVICHEV, V. V.

(Nauchnye osnovy kosmicheskogo proizvodstva, Moscow, Izdatel'stvo Mir, 1984) Moscow, Mir Publishers, 1984, 176 p. Translation.

Publication Date: 1984 79 Refs.

Language: English

Country of Origin: U.S.S.R. Country of Publication: U.S.S.R.

Document Type: BOOK; TRANSLATION

Most documents available from AIAA Technical Library

Journal Announcement: IAA8524

A review is given of Soviet efforts to develop platforms and techniques for materials processing in outer space. Consideration is given to the physical conditions on board a space-based materials processing platform, including the fluid mechanics of microgravity; dynamic weightlessness; and

transport phenomena. Thermodynamic and kinetic aspects of phase transitions in microgravity are discussed, with emphasis given to solidification and heat transfer; the distribution of impurities; and the formation of structural defects in materials (metals, semiconductors and glasses) which are processed in space. Techniques for modeling the reactions of materials and material processes to microgravity are also described based on experimental data collected during the Soyuz and Salyut missions. (I.H.)

Source of Abstract/Subfile: AIAA/TIS

Descriptors: \*AEROSPACE SCIENCES; \*LOW GRAVITY MANUFACTURING; \*MICROGRAVITY APPLICATIONS; \*REDUCED GRAVITY; \*SPACE MANUFACTURING; \*SPACE PLATFORMS; FLUID MECHANICS; HEAT TRANSFER; MASS TRANSFER; MATHEMATICAL MODELS; PHASE TRANSFORMATIONS; SOLIDIFICATION

Subject Classification: 7512 .Astronautics--General (1975-)

1407381 A85-47047

**NASA approves fly-now, pay-later plans for orbiting industrial facility**

COVAULT, C.

Aviation Week and Space Technology (ISSN 0005-2175), vol. 123, Aug. 26, 1985, p. 16, 17.

Publication Date: Aug. 1985

Language: English

Country of Origin: United States Country of Publication: United States

Document Type: JOURNAL ARTICLE

Most documents available from AIAA Technical Library

Journal Announcement: IAA8522

In a continuing effort to foster the commercialization of space, NASA has entered into an agreement with Space Industries, Inc. to furnish that company with two STS launches which will be paid for in the form of 12 percent of the revenues from the first five years of operation. The payload will be a Shuttle-tended unmanned module for materials processing. NASA also plans to benefit from access to the module and docking facility technologies which will be developed by the commercial organization. This will avoid in-house development costs for NASA. The first module will be 35 ft long and 14.5 ft wide and will cost from \$250-500 million to develop. The initial launch is scheduled for 1992. Module power will be furnished by 100-ft long solar cell masts rated at 12 kW. The orbit will be selected to allow operations in concert with the Space Station orbit, thereby facilitating Orbiter visits. (M.S.K.)

Source of Abstract/Subfile: AIAA/TIS

Descriptors: \*NASA PROGRAMS; \*SPACE INDUSTRIALIZATION; \*SPACE PROCESSING; \*SPACE SHUTTLE PAYLOADS; SPACE COMMERCIALIZATION; SPACECRAFT DESIGN; SPACECRAFT MODULES

Subject Classification: 7518 .Spacecraft Design, Testing & Performance (1975-)

## DIALOG File 108: AEROSPACE - 62-86/ISS09

1407373 A85-47039

**The Issue is Leadership (Space Station program)**

BEGGS, J. M. (NASA, Washington, DC)

National Aeronautics and Space Administration, Washington, D. C.

Corp. Source Code: NC452981

Aerospace America (ISSN 0740-722X), vol. 23, Sept. 1985, p. 44-47.

Publication Date: Sep. 1985

Language: English

Country of Origin: United States Country of Publication: United States

Document Type: JOURNAL ARTICLE

Most documents available from AIAA Technical Library

Journal Announcement: IAA8522

Four NASA Phase B centers (NASA-Johnson, NASA-Marshall, NASA-Goddard, and NASA-Lewis) are responsible for construction, assembly, servicing, habitat, and other particular tasks and functions of the Space Station. The project has been joined by the aerospace programs of Canada, Japan, and the European Space Agency, ensuring technological and financial support, and cooperative use by the participants. Some of the future uses of the Space Station include biomedical research and applications; experiments in solar-terrestrial physics and astronomy; building, maintenance, and launching of space instruments and planetary missions; manufacturing and processing of materials that call for the conditions of microgravity and weightlessness; supporting communication operations; and improving earth and atmospheric observations. The political significance of the Space Station as a symbol of leadership and of friendly cooperation is noted. (I.S.)

Source of Abstract/Subfile: AIAA/TIS

Descriptors: \*NASA PROGRAMS; \*ORBITAL SPACE STATIONS; \*SPACE STATIONS; COST ANALYSIS; SPACE LABORATORIES; SPACE MAINTENANCE; SPACE MANUFACTURING

Subject Classification: 7512 .Astronautics--General (1975-)

1398963 N85-29979

**International space research perspectives of commercialization for German Industry**

JORDAN, H. L.

National Aeronautics and Space Administration, Washington, D. C.

Corp. Source Code: NC452981

Publication Date: Jul. 1985 3IP.

Translation Note: Transl. into ENGLISH of

"Weltraumforschung - perspektiven der kommerziellen nutzung fur die deutsche industrie" Linder Hoehe, West Germany, 19 Oct. 1984 16 p

Publication Note: Transl. by Scientific Translation Service, Santa Barbara, Calif. Original document prepared by DFVLR, Linder Hoeh, West Germany

Presentation Note: Presented at Meeting of the Comm. for the Politics of Res. and Sci., Bonn, 19 Oct. 1984

Report No.: NASA-TM-77657; NAS 1.15:77657

Contract No.: NASW-4004

Language: English

Country of Origin: Germany, Federal Republic of Country of

Publication: United States

Document Type: REPORT; CONFERENCE PAPER; TRANSLATION

Most documents available from AIAA Technical Library

Other Availability: NTIS HC A03/MF A01

Journal Announcement: STAR8519

A brief overview of space flight activities is presented. West German contributions to satellite mapping, communication satellites, navigation, Spacelab, diffusion under weightlessness, crystal growth in space, metal bonding, and biochemistry are described. The future of the research in the space station is analyzed. (B.W.)

Source of Abstract/Subfile: NASA STIF

Descriptors: \*COMMUNICATION SATELLITES; \*DIFFUSION; \*SPACE COMMERCIALIZATION; \*SPACE MANUFACTURING; \*SPACE STATIONS; \*SPACELAB; \*WEST GERMANY; \*BIOCHEMISTRY; \*CRYSTAL GROWTH; \*SATELLITE IMAGERY

Subject Classification: 7512 .Astronautics--General (1975-)

COSATI Code: 22A .Astronautics

1396072 A85-39930

**Commercialization of a Space Station**

SHESKIN, T. J. (Cleveland State University, Cleveland, OH)

American Society of Mechanical Engineers, Winter Annual Meeting, New Orleans, LA, Dec. 9-14, 1984. 5 p.

Publication Date: Dec. 1984 10 Refs.

Report No.: ASME PAPER 84-WA/TS-3

Language: English

Country of Origin: United States Country of Publication: United States

Document Type: PREPRINT

Most documents available from AIAA Technical Library

Journal Announcement: IAA8518

A Space Station will create new opportunities for commercial investment. This paper explores two of the most promising areas: materials processing in space, and the servicing and launching of communications satellites. Risks to commercial investors are identified. Recommendations are offered for providing incentives to private sector companies to invest in a Space Station. (Author)

Source of Abstract/Subfile: AIAA/TIS

Descriptors: \*ORBITAL SERVICING; \*ORBITAL SPACE STATIONS; \*SPACE COMMERCIALIZATION; \*SPACE PROCESSING; COMMUNICATION SATELLITES; MARKET RESEARCH; MATERIALS SCIENCE; ORBITAL LAUNCHING; RISK; WEIGHTLESSNESS

Subject Classification: 7512 .Astronautics--General (1975-)

1386936 A85-34538

**Commercial use of space - The space business era**

GRIFFIN, G. D. (NASA, Johnson Space Center, Houston, TX)

National Aeronautics and Space Administration, Lyndon B.

(cont. next page)

## DIALOG File 108: AEROSPACE - 62-86/ISS09

Johnson Space Center, Houston, Tex.

Corp. Source Code: ND052615

(U.S. Space Technology Conference and Exhibition, Zurich, Switzerland, June 19-21, 1984) Space Solar Power Review (ISSN 0191-9067), vol. 5, no. 1, 1985, p. 77-82.

Publication Date: 1985

Language: English

Country of Origin: United States Country of Publication: United States

Document Type: JOURNAL ARTICLE; CONFERENCE PAPER

Most documents available from AIAA Technical Library

Journal Announcement: IAA8515

Progress and avenues being explored by NASA to hasten the commercialization of space are described. A task force has recommended that the effort begin at once, that bureaucratic barriers to commercial space activities be removed, and that a partnership between government and industry be seriously explored. The government role is to establish links with private industry, invest in high-leverage technologies and space facilities which will be attractive to commercial ventures, and contribute to commercial enterprises where risks are high and significant economic benefits can be foreseen. The government/industry relationship can be legally evinced by MOUs, joint endeavor agreements, technical exchange agreements and industrial guest investigator arrangements. The Space Station is the first step in that it allows Americans to live and work in space. It is expected that international participation in Space Station development and utilization will accelerate the space business era. (M.S.K.)

Source of Abstract/Subfile: AIAA/TIS

Descriptors: \*AEROSPACE INDUSTRY; \*COMMERCIAL SPACECRAFT; \*SPACE COMMERCIALIZATION; \*SPACE MANUFACTURING; CATALYSTS; CRYSTAL GROWTH; EUROPEAN SPACE AGENCY; GRAPHITE; INTERNATIONAL COOPERATION; NASA PROGRAMS; SPACE INDUSTRIALIZATION; SPACE PLATFORMS; SPACE TRANSPORTATION SYSTEM; SPACELAB; THIN FILMS

Subject Classification: 7512 .Astronautics--General (1975-)

1386614 A85-34216

**An astronaut's look at commercial space opportunities**

COLLINS, M.

Commercial Space (ISSN 8756-4831), vol. 1, Spring 1985, p. 24-26.

Publication Date: 1985

Language: English

Country of Origin: United States Country of Publication: United States

Document Type: JOURNAL ARTICLE

Most documents available from AIAA Technical Library

Journal Announcement: IAA8515

The commercial opportunities provided by space are related to the unique qualities of the space environment. These qualities are discussed, taking into account weightlessness, a practically perfect vacuum, the great differences between hot and cold, the continuous supply of solar energy, the charged particles, good visibility, absence of noise, the practically infinite size of space, and the high costs of gaining access

to it. These qualities make possible the production of very precise spheres for calibration purposes, and the manufacture of ultra-pure glass and other materials. The production of rare pharmaceuticals in space is likely to have an early payoff, while the production of gallium-arsenide crystals for electronic devices is also very promising. However, the great risks involved in space ventures together with long payback times and the required large investments exert a retarding influence on space commercialization. Attention is given to the role of the government in space and opportunities provided by the Space Station. (G.R.)

Source of Abstract/Subfile: AIAA/TIS

Descriptors: \*GOVERNMENT/INDUSTRY RELATIONS; \*ORBITAL SPACE STATIONS; \*SPACE COMMERCIALIZATION; \*SPACE MANUFACTURING; \*SPACE PROCESSING; \*TECHNOLOGICAL FORECASTING; CRYSTAL GROWTH GALLIUM ARSENIDES; NASA PROGRAMS; PRODUCTION ENGINEERING; SPACEBORNE EXPERIMENTS; VACUUM EFFECTS; WEIGHTLESSNESS

Subject Classification: 7512 .Astronautics--General (1975-)

1386613 A85-34215

**Investors balance enthusiasm for new market against risk potential**

SHIFRIN, C. A.

Commercial Space (ISSN 8756-4831), vol. 1, Spring 1985, p. 19-21.

Publication Date: 1985

Language: English

Country of Origin: United States Country of Publication: United States

Document Type: JOURNAL ARTICLE

Most documents available from AIAA Technical Library

Journal Announcement: IAA8515

Although the interest in commercial space projects is increasing, the investment community shows caution and hesitancy regarding a commitment to such projects. The caution is a result of the particular situation which exists with respect to space-related commercial projects. They require generally a large amount of capital, the potential return on investment may be years off, and the risks, compared with other potential investments, appear greater. There are, however, a number of entrepreneurial companies which are finding capital for commercial space projects. One is developing Space Shuttle upper stages and vehicles to be used to launch commercial satellites, while another is concerned with the growing of crystals in space. A third company is developing a free-flying man-tended laboratory platform to be used for materials processing and other activities. Attention is also given to a number of Fortune 500 companies which are getting involved in commercial space projects. (G.R.)

Source of Abstract/Subfile: AIAA/TIS

Descriptors: \*CRYSTAL GROWTH; \*INVESTMENTS; \*MARKET RESEARCH; \*RISK; \*SPACE COMMERCIALIZATION; \*SPACE PROCESSING; FINANCIAL MANAGEMENT; MATERIALS SCIENCE; ORBIT TRANSFER VEHICLES; ORBITAL LAUNCHING; PROJECT PLANNING; RESEARCH

(cont. next page)

ORIGINAL PAGE IS  
OF POOR QUALITY

## DIALOG File 108: AEROSPACE - 62-86/ISS09

PROJECTS: SPACE PLATFORMS; SPACE SHUTTLE ORBITERS; SPACEBORNE EXPERIMENTS

Subject Classification: 7583 .Economics & Cost Analysis (1975-)

1386612 A85-34214

**Evolving government policy eases way for space ventures**  
COVAULT, C.

Commercial Space (ISSN 8756-4831), vol. 1, Spring 1985, p. 14-18.

Publication Date: 1985

Language: English

Country of Origin: United States Country of Publication: United States

Document Type: JOURNAL ARTICLE

Most documents available from AIAA Technical Library

Journal Announcement: IA8515

It is pointed out that the formation of a commercial space policy at both the White House and NASA has introduced greater predictability into corporate planning for space ventures. As a consequence of this development, new groups have begun to show interest in commercial space endeavors. These groups include a broader cross section of finance and lending institutions, state and local governments interested in stimulating space business in their geographical areas, and more companies with innovative ideas. According to a new analysis, gross annual revenues for all commercial space endeavors should total between \$44.5 billion and \$53 billion by the year 2000. The key areas of NASA policy interest for the next two years are related to centers for commercial development, technology utilization, new NASA facilities, limited seed funding, and expanded agreements. (G.R.)

Source of Abstract/Subfile: AIAA/TIS

Descriptors: \*GOVERNMENT/INDUSTRY RELATIONS; \*NASA PROGRAMS \*POLICIES; \*SPACE COMMERCIALIZATION; \*TECHNOLOGY UTILIZATION; COST INCENTIVES; CRYSTAL GROWTH; ORBITAL SPACE STATIONS; SPACE PROCESSING; SPACE SHUTTLE ORBITERS; SPACEBORNE EXPERIMENTS

Subject Classification: 7512 .Astronautics--General (1975-)

1372619 N85-18993

**Commerce lab: Mission analysis and payload integration study**

Interim Progress Report

Wyle Labs., Inc., Huntsville, Ala.

Corp. Source Code: W9307657

Publication Date: Dec. 1984 87P.

Report No.: NASA-CR-174381; NAS 1.26:174381

Contract No.: NAS8-36109

Language: English

Country of Origin: United States Country of Publication: United States

Document Type: REPORT

Most documents available from AIAA Technical Library

Other Availability: NTIS HC A05/MF A01

Journal Announcement: STAR8510

Conceived as one or more arrays of carriers which would fly

aboard space shuttle, Commerce Lab can provide a point of focus for implementing a series of shuttle flights, co-sponsored by NASA and U.S. domestic concerns, for performing materials processing in research and pre-commercial investigations. As an orbiting facility for testing, developing, and implementing hardware and procedures, Commerce Lab can enhance space station development and hasten space platform production capability. Tasks considered include: (1) synthesis of user requirements and identification of common element and voids; (2) definition of performance and infrastructure requirement and alternative approaches; and (3) carrier, mission model, and infrastructure development. (A.R.H.)

Source of Abstract/Subfile: NASA STIF

Descriptors: \*REDUCED GRAVITY; \*SPACE COMMERCIALIZATION; \*SPACE LABORATORIES; \*SPACE PROCESSING; \*SPACE SHUTTLE PAYLOADS; \*USER REQUIREMENTS; GOVERNMENT/INDUSTRY RELATIONS; INTERFACES; MISSION PLANNING; PAYLOAD INTEGRATION PLAN; SPACEBORNE EXPERIMENTS; TRADEOFFS

Subject Classification: 7512 .Astronautics--General (1975-)

COSATI Code: 22A .Astronautics

1363400 A85-20512

**Astrobusiness: A guide to the commerce and law of outer space** (Book)

FINCH, E. R., JR. (Finch and Schaefer, New York, NY); MOORE, A. L.

New York, Praeger, 1985, 157 p.

Publication Date: 1985 89 Refs.

Language: English

Country of Origin: United States Country of Publication: United States

Document Type: BOOK

Journal Announcement: IA8507

This book documents the commercialization of outer space by the incredible growth of space-related opportunities for the private sector. The commercial uses of space are related to communications, remote sensing, space manufacturing, and energy. Possibilities of a manufacture in space are considered for pharmaceuticals, electronics, glass, and metallurgy. Structures for space discussed include Spacelab, space platforms, the Space Station, and space structures in geostationary orbit, a high orbit between the earth and the moon, and on the moon itself. Attention is also given to space transportation services, space risks and liabilities, questions regarding the financing of business in space, the national space law, international space law, and the militarization of space. An outlook is provided regarding future commercial space business opportunities. (G.R.)

Source of Abstract/Subfile: AIAA/TIS

Descriptors: \*COMMERCIAL SPACECRAFT; \*SPACE COMMERCIALIZATION; \*SPACE INDUSTRIALIZATION; \*SPACE LAW; COMMUNICATION SATELLITES; EARTH OBSERVATIONS (FROM SPACE); FINANCIAL MANAGEMENT; GOVERNMENT/INDUSTRY RELATIONS; LEGAL LIABILITY;

(cont. next page)

## DIALOG File 108: AEROSPACE - 82-88/ISS09

MILITARY SPACECRAFT; ORBITAL SPACE STATIONS; SPACE  
MANUFACTURING; SPACE PLATFORMS; SPACE TRANSPORTATION

Subject Classification: 7512 .Astronautics--General (1975-)

1357647 A76-46105

**Economy of in-orbit manufacturing and processing**

GREGER, G. (Bundesministerium fuer Forschung und  
Technologie, Bonn, West Germany)

International Astronautical Federation, International  
Astronautical Congress, 27th, Anaheim, Calif., Oct. 10-16,  
1976, 12 p.

Publication Date: Oct. 1976 7 Refs.

Report No.: IAF PAPER A-76-25

Language: English

Country of Origin: Germany, Federal Republic of Country of

Publication: International Organization

Document Type: CONFERENCE PAPER

Most documents available from AIAA Technical Library

Journal Announcement: IAA7623

Manned orbital systems will, for the first time, enable  
technological basic research to be carried out which allows  
long-term development under space conditions. But space  
technology will not be able to avail itself of this  
opportunity of making an important contribution to increasing  
industrial efficiency and competitiveness unless a convincing  
breakthrough can be made towards greater economy of space  
flight operations. The present paper discusses selected  
examples of materials research and process engineering which  
show such approaches. Furthermore, it reports on  
considerations made and measures envisaged by the German space  
program to establish the necessary prerequisites for  
economical operation. ((Author))

Descriptors: \*ECONOMIC FACTORS; \*METALLURGY; \*MICROELECTRON-  
ICS; \*SPACE MANUFACTURING; EUROPEAN SPACE PROGRAMS; NETWORK  
SYNTHESIS; PAYLOADS; TECHNOLOGICAL FORECASTING; TURBINE BLADES

Subject Classification: 7512 .Astronautics--General (1975-)

1343911 A76-32369

**An orbital chemical plant for production of propellant and  
structural materials**

NAGATOMO, M. (Tokyo, University, Tokyo, Japan); KANZAWA, A.  
(Tokyo Institute of Technology, Tokyo, Japan)

In: International Symposium on Space Technology and Science,  
11th, Tokyo, Japan, June 30-July 4, 1975, Proceedings.  
(A76-32301 15-12) Tokyo, AGNE Publishing, Inc., 1975, p.  
501-506.

Publication Date: 1975

Language: English

Country of Origin: Japan Country of Publication: Japan

Document Type: CONFERENCE PAPER

Journal Announcement: IAA7615

The large payload capability of the launch system like Space  
Shuttle will make it possible, not only to carry great amount  
of consumables and structural materials for the use in orbit,  
but also to construct a plant or a factory to produce such

necessaries in space. Such a facility in orbit is advantageous  
from two points. The first one is that the massive materials  
can be carried in the most suitable form as the cargo of the  
launch vehicle, and the second is that solar energy is  
available on the earth orbit as energy source for materials  
processing. In the present paper, concept of a chemical plant  
is shown which produces propellant for orbital rocket vehicle  
and structural materials for constructing space stations. The  
chemical process discussed here is thermal dissociation of  
hydrocarbon into hydrogen and carbon black in a solar energy  
furnace. The orbital chemical plant consists of the furnace  
with accessories, a hydrogen liquefier and a carbon material  
processing facility. ((Author))

Descriptors: \*CHEMICAL ENGINEERING; \*CONSTRUCTION MATERIALS  
\*HYDROCARBON FUEL PRODUCTION; \*ORBITAL WORKSHOPS; \*SPACE  
MANUFACTURING; METHANE; ORBITAL ASSEMBLY; PYROLYSIS; SPACE  
SHUTTLES; SPACECRAFT MODULES

Subject Classification: 7512 .Astronautics--General (1975-)

1343898 A76-32356

**Space processing - Status, prospects and problems: 1975**

STEG, L.; MCCREIGHT, L. R. (GE Space Sciences Laboratory,  
Philadelphia, Pa.)

In: International Symposium on Space Technology and Science,  
11th, Tokyo, Japan, June 30-July 4, 1975, Proceedings.  
(A76-32301 15-12) Tokyo, AGNE Publishing, Inc., 1975, p.  
409-415.

Publication Date: 1975 22 Refs.

Language: English

Country of Origin: United States Country of Publication:  
Japan

Document Type: CONFERENCE PAPER

Journal Announcement: IAA7615

In the past decade, several ideas have been advanced for  
utilizing the prolonged low gravity available on spacecraft to  
process materials for use on earth. The validity of a few of  
them have been demonstrated on the Apollo flights and on  
Skylab. In particular, some crystals grown by solidification  
techniques on Skylab have provided indications that the  
predicted improvements in perfection can be gained under  
minimal gravity induced convection and sedimentation  
conditions. The far greater capabilities of the space shuttle  
for extending the range and quantities of experiments are now  
being awaited. In the interim, the Apollo Soyuz Test Project,  
sounding rocket flights to provide a few minutes of  
microgravity experimental time and numerous ground-based  
experiments and studies are being performed or planned. These  
are briefly reviewed in this paper. ((Author))

Descriptors: \*LOW GRAVITY MANUFACTURING; \*MATERIALS SCIENCE  
\*SPACE MANUFACTURING; \*TECHNOLOGY ASSESSMENT; AEROSPACE  
SCIENCES; APOLLO SOYUZ TEST PROJECT; CRYSTAL GROWTH;  
EXPERIMENT DESIGN; REDUCED GRAVITY; SOUNDING ROCKETS;  
TECHNOLOGICAL FORECASTING

Subject Classification: 7512 .Astronautics--General (1975-)

## DIALOG File 108: AEROSPACE - 82-88/ISS09

1341190 N85-14438

**Bioprocessing in space**

BONTING, S. L.

Nijmegen Univ. (Netherlands). Dept. of Biochemistry.

Corp. Source Code: N1473382

In ESA Life Sci. Res. in Space p 75-78 (SEE N85-14425 05-51)

Publication Date: Aug. 1984

Language: English

Country of Origin: Norway Country of Publication:

## International Organization

Document Type: CONFERENCE PAPER

Most documents available from AIAA Technical Library

Other Availability: NTIS HC A14/MF AO1

Journal Announcement: STAR8505

The technical, biological, and financial aspects of bioprocessing medical products in space using continuous free-flow electrophoresis (CFE) are discussed. Specifications for a CFE apparatus are suggested. Candidate materials, e.g., erythropoietin for anemia and pancreas beta cells for diabetes, are listed. (Author (ESA))

Source of Abstract/Subfile: ESA

Descriptors: \*BIOPROCESSING; \*BIOSYNTHESIS; \*ELECTROPHORESIS; \*PHARMACOLOGY; \*SPACE PROCESSING; ECONOMIC FACTORS; FUNCTIONAL DESIGN SPECIFICATIONS; SPACE MANUFACTURING

Subject Classification: 7551 Life Sciences--General (1975-)

1335300 A85-13142

**Activities in Germany for the commercialization of space**

KLEBER, P. (Deutsche Forschungs- und Versuchsanstalt fuer Luft- und Raumfahrt, Cologne, West Germany)

International Astronautical Federation, International Astronautical Congress, 35th, Lausanne, Switzerland, Oct. 7-13, 1984. 7 p.

Publication Date: Oct. 1984

Report No.: IAF PAPER 84-222

Language: English

Country of Origin: Germany, Federal Republic of Country of

## Publication: International Organization

Document Type: PREPRINT

Most documents available from AIAA Technical Library

Journal Announcement: IAA8503

The benefits space has to offer to industrial concerns are discussed with an eye to methods of arousing greater industrial participation. Future technological development hinges on exploitation of the microgravity environment, particularly the free fall produced by blancing the spacecraft velocity against the centripetal force. Preliminary experimentation growing single crystals, studying diffusion in materials, the growth of living, cells, etc., must be expanded upon by inducing further trials by more industrial investigators. Interest can be heightened through media advertizing, direct mailing, personal contact, and exhibits at industrial fairs. Industrial interest is most likely in the fields of metallic materials, electronics, chemistry, pharmaceuticals, and basic research. The promotions should be targeted at raising executive-level awareness of the

possibilities space offers. (M.S.K.)

Source of Abstract/Subfile: AIAA/TIS

Descriptors: \*REDUCED GRAVITY; \*SPACE COMMERCIALIZATION; \*SPACE INDUSTRIALIZATION; \*SPACE MANUFACTURING; \*SPACE PROCESSING; CHEMISTRY; ELECTRONICS; LOW GRAVITY MANUFACTURING MATERIALS SCIENCE; PHARMACOLOGY; WEST GERMANY

Subject Classification: 7512 Astronautics--General (1975-)

1335297 A85-13139

**NASA's approach to the commercial use of space**

GILLAM, I. T., IV (NASA, Washington, DC)

National Aeronautics and Space Administration, Washington, D. C.

Corp. Source Code: NC452981

International Astronautical Federation, International Astronautical Congress, 35th, Lausanne, Switzerland, Oct. 7-13, 1984. 6 p.

Publication Date: Oct. 1984

Report No.: IAF PAPER 84-217

Language: English

Country of Origin: United States Country of Publication:

## International Organization

Document Type: PREPRINT

Most documents available from AIAA Technical Library

Journal Announcement: IAA8503

NASA planning activities in the area of commercial development of space resources are reviewed. Examples of specific types of commercial space ventures are given, according to three different categories: new commercial high-technology ventures; new commercial application of existing space technology, and commercial ventures resulting from the transfer of existing space programs to the private sector. Basic objectives for reducing technical, financial and institutional risks for commercial space operations are considered. Attention is given to the cooperative working environment encouraged by Joint Endeavor Agreements (JEAs) and Technical Exchange Agreements (TEAs) between industrial organizations in the development of space systems. Benefits of the commercial development of space resources include the production of purer pharmaceuticals for the treatment of cancers, kidney diseases, and diabetes; and the development of ultra-pure semiconductor crystals for use in next generation electronic equipment. (I.H.)

Source of Abstract/Subfile: AIAA/TIS

Descriptors: \*AEROSPACE INDUSTRY; \*GOVERNMENT/INDUSTRY RELATIONS; \*NASA PROGRAMS; \*SPACE COMMERCIALIZATION; \*SPACE INDUSTRIALIZATION; COMMERCIAL SPACECRAFT; ECONOMIC FACTORS; RISK

Subject Classification: 7512 Astronautics--General (1975-)



## DIALOG File 108: AEROSPACE - 82-88/ISS09

1331519 N85-11055

**Opportunities for commercial organizations**

Abstract Only

VARDAMAN, W. K.; ATKINS, H.; TAYLOR, K. R.

National Aeronautics and Space Administration. Marshall Space Flight Center, Huntsville, Ala.

Corp. Source Code: ND736801

In its 2nd Symp. on Space Industrialization p 369. (SEE N85-11011 02-12)

Publication Date: Oct. 1984

Language: English

Country of Origin: United States Country of Publication: United States

Document Type: CONFERENCE PAPER

Most documents available from AIAA Technical Library

Other Availability: NTIS HC A19/MF AO1

Journal Announcement: STAR8502

The possible applications of technology of materials processing in low gravity is discussed. A special office established by NASA to familiarize commercial organizations with materials processing in low gravity is described. This office provides information on present research and will, if requested, hold a seminar to present the technological and business aspects of joint investigations and joint endeavors to interested organizations. Arrangements can be made for visits to laboratories where ground based research is in progress. (M.A.C.)

Source of Abstract/Subfile: NASA STIF

Descriptors: \*INFORMATION DISSEMINATION; \*SPACE COMMERCIALIZATION; \*SPACE PROCESSING; \*TECHNOLOGY ASSESSMENT; \*TECHNOLOGY TRANSFER; EXPERIMENT DESIGN; GOVERNMENT/INDUSTRY RELATIONS; INDUSTRIES; PROJECT MANAGEMENT; REDUCED GRAVITY

Subject Classification: 7581 Administration &amp; Management (1975-)

COSATI Code: 5A Administration &amp; Management

1331518 N85-11054

**Advances in electrophoretic separations**

Abstract Only

SNYDER, R. S.; RHODES, P. H.

National Aeronautics and Space Administration. Marshall Space Flight Center, Huntsville, Ala.

Corp. Source Code: ND736801

In its 2nd Symp. on Space Industrialization p 368 (SEE N85-11011 02-12)

Publication Date: Oct. 1984

Language: English

Country of Origin: United States Country of Publication: United States

Document Type: CONFERENCE PAPER

Most documents available from AIAA Technical Library

Other Availability: NTIS HC A19/MF AO1

Journal Announcement: STAR8502

Free fluid electrophoresis is described using laboratory and space experiments combined with extensive mathematical modeling. Buoyancy driven convective flows due to thermal and

concentration gradients are absent in the reduced gravity environment of space. The elimination of convection in weightlessness offers possible improvements in electrophoresis and other separation methods which occur in fluid media. The mathematical modeling suggests new ways of doing electrophoresis in space and explains various phenomena observed during past experiments. The extent to which ground based separation techniques are limited by gravity induced convection is investigated and space experiments are designed to evaluate specific characteristics of the fluid/particle environment. A series of experiments are proposed that require weightlessness and apparatus is developed that can be used to carry out these experiments in the near future. (M.A.C.)

Source of Abstract/Subfile: NASA STIF

Descriptors: \*ELECTROPHORESIS; \*EXPERIMENT DESIGN; \*MATHEMATICAL MODELS; \*SPACE COMMERCIALIZATION; \*TECHNOLOGY ASSESSMENT; FLUID DYNAMICS; FLUID FLOW; TECHNOLOGICAL FORECASTING; WEIGHTLESSNESS

Subject Classification: 7525 Inorganic &amp; Physical Chemistry (1975-)

COSATI Code: 7D Physical Chemistry

1331482 N85-11018

**Opportunities for space bioprocessing**

BIER, M.

Arizona Univ., Tucson. Biophysics Technology Lab.

Corp. Source Code: AX852975

In NASA. Marshall Space Flight Center 2nd Symp. on Space Industrialization p 60-64 (SEE N85-11011 02-12)

Publication Date: Oct. 1984

Language: English

Country of Origin: United States Country of Publication: United States

Document Type: CONFERENCE PAPER

Most documents available from AIAA Technical Library

Other Availability: NTIS HC A19/MF AO1

Journal Announcement: STAR8502

The need for improved purification technologies, the role of electrophoresis, and isoelectric focusing are discussed in the context of space bioprocessing. (R.S.F.)

Source of Abstract/Subfile: NASA STIF

Descriptors: \*BIOPROCESSING; \*BIOTECHNOLOGY; \*ELECTROPHORESIS; \*PURIFICATION; \*SPACE PROCESSING; GENETIC ENGINEERING; PH FACTOR; REDUCED GRAVITY; SPACE COMMERCIALIZATION; SPACE TRANSPORTATION SYSTEM 11 FLIGHT

Subject Classification: 7512 Astronautics--General (1975-)

COSATI Code: 22A Astronautics

1331478 N85-11014

**Financial issues for commercial space ventures: Paying for the dreams**

EGAN, J. J.

Coopers and Lybrand, Washington, D.C.

(cont. next page)

## DIALOG File 108: AEROSPACE - 62-86/ISS09

Corp. Source Code: C4643564  
 In NASA. Marshall Space Flight Center 2nd Symp. on Space  
 Industrialization p 38-47 (SEE N85-11011 02-12).  
 Publication Date: Oct. 1984  
 Language: English  
 Country of Origin: United States Country of Publication:  
 United States

Document Type: CONFERENCE PAPER  
 Most documents available from AIAA Technical Library  
 Other Availability: NTIS HC A19/MF A01  
 Journal Announcement: STAR8502  
 Various financial issues involved in commercial space  
 enterprise are discussed. Particular emphasis is placed on the  
 materials processing area: the current state of business plan  
 and financial developments, what is needed for enhanced  
 probability of success of future materials development efforts  
 in attracting financial backing, and finally, the risks  
 involved in this entire business area. (R.S.F.)

Source of Abstract/Subfile: NASA STIF  
 Descriptors: \*FINANCE; \*MARKETING; \*SPACE COMMERCIALIZATION  
 \*SPACE PROCESSING; INVESTMENTS; LIFE CYCLE COSTS; RISK  
 Subject Classification: 7583 .Economics & Cost Analysis  
 (1975-)  
 COSATI Code: 5C .Economics

1331475 N85-11011  
 Second Symposium on Space Industrialization (space  
 commercialization)  
 JERNIGAN, C. M., ed.  
 National Aeronautics and Space Administration. Marshall  
 Space Flight Center, Huntsville, Ala.  
 Corp. Source Code: ND736801  
 Publication Date: Oct. 1984 427P.  
 Publication Note: Sponsored in cooperation with AIAA and  
 Alabama Univ.  
 Presentation Note: Symp. held in Huntsville, Ala., 13-15  
 Feb. 1984

Report No.: NASA-CP-2313; M-464; NAS 1.55:2313  
 Language: English  
 Country of Origin: United States Country of Publication:  
 United States

Document Type: COLLOQUIA  
 Most documents available from AIAA Technical Library  
 Other Availability: NTIS HC A19/MF A01  
 Journal Announcement: STAR8502  
 The policy, legal, and economic aspects of space  
 industrialization are considered along with satellite  
 communications, material processing, remote sensing, and the  
 role of space carriers and a space station in space  
 industrialization. For individual titles see N85-11012  
 through N85-11057.

Descriptors: \*BIOPROCESSING; \*COMMUNICATION; \*CONFERENCES;  
 \*ECONOMIC FACTORS; \*GOVERNMENT/INDUSTRY RELATIONS; \*LAUNCH  
 VEHICLES; \*LAW (JURISPRUDENCE); \*POLICIES; \*REDUCED GRAVITY;  
 \*REMOTE SENSING; \*SPACE COMMERCIALIZATION; \*SPACE  
 INDUSTRIALIZATION; \*SPACE PROCESSING; \*SPACE STATIONS;

AGRICULTURE; BUDGETS; CRYSTAL GROWTH; DROP TOWERS;  
 ELECTROPHORESIS; EURECA (ESA); EUROPEAN SPACE AGENCY; GALLIUM  
 ARSENIDES; GLASS; IRON; LANDSAT SATELLITES; LATEX; MANNED  
 ORBITAL RESEARCH LABORATORIES; NASA PROGRAMS; SATELLITE  
 IMAGERY; SOLIDIFICATION; SPACE MANUFACTURING; SPACE PLATFORMS  
 SPACE SHUTTLE PAYLOADS; SPACECRAFT MAINTENANCE; TECHNOLOGY  
 ASSESSMENT; TECHNOLOGY UTILIZATION

Subject Classification: 7512 .Astronautics--General (1975-)  
 COSATI Code: 22A .Astronautics

1328769 A84-49146  
 Leasecraft - A commercial space platform  
 BURROWBRIDGE, D. R. (Fairchild Space Co., Germantown, MD)  
 IN: Satellite land remote sensing advancements for the  
 eighties; Proceedings of the Eighth Pecora Symposium, Sioux  
 Falls, SD, October 4-7, 1983 (A84-49131 24-43). Sioux Falls,  
 SD, Augustana College, 1984, p. 228-243.

Publication Date: 1984  
 Language: English  
 Country of Origin: United States Country of Publication:  
 United States

Document Type: CONFERENCE PAPER  
 Most documents available from AIAA Technical Library  
 Journal Announcement: IAAB424

The Multimission Modular Spacecraft (MMS) is the result of a  
 NASA program concerned with the identification of new  
 approaches to spacecraft design. A mandatory requirement  
 regarding the MMS was flexibility to accommodate a wide  
 variety of payloads. MMS derived subsystems will provide a  
 platform in low orbit for scientific, commercial, and  
 government users on a leased or service contract basis. The  
 payload may consist of scientific instruments, materials  
 processing equipment, or remote sensors. Secondary payloads  
 may be mounted in standard MMS module boxes. The platform  
 forms a part of the 'Leasecraft' system, which was developed  
 by an American aerospace company. Attention is given to the  
 Leasecraft vehicle, details regarding the Leasecraft platform,  
 and payload accommodations and Leasecraft missions. (G.R.)

Source of Abstract/Subfile: AIAA/TIS  
 Descriptors: \*COMMERCIAL SPACECRAFT; \*LEASING; \*MULTIMISSION  
 MODULAR SPACECRAFT; \*PAYLOADS; \*SPACE COMMERCIALIZATION;  
 \*SPACE PLATFORMS; ATTITUDE CONTROL; EARTH ORBITS; NASA  
 PROGRAMS; REMOTE SENSORS; SOLAR MAXIMUM MISSION  
 Subject Classification: 7515 .Launch Vehicles & Space  
 Vehicles (1975-)

1320848 A84-41224  
 Materials processing in space - Plenty of prophets, but what  
 about profits?

BULLOCH, C.  
 Interavia (ISSN 0020-5168), vol. 39, July 1984, p. 679-683.  
 Publication Date: Jul. 1984  
 Language: English

(cont. next page)

ORIGINAL QUALITY  
 OF POOR QUALITY

## DIALOG File 108: AEROSPACE - 62-86/ISS09

Country of Origin: Switzerland Country of Publication: Switzerland

Document Type: JOURNAL ARTICLE

Most documents available from AIAA Technical Library

Journal Announcement: IAAB420

The economics of space processing, the benefits of manufacturing in space and the technologies most likely to succeed in terms of yielding commercially viable products are surveyed. One estimate indicated that space-processed substances must be worth \$10,000-100,000/lb to turn a profit on earth. Space offers high vacuum, low gravity, and an infinite 'heat-sink' for experiments and manufacturing. Melt, solution and float zone growth of semiconductor crystals is being examined. Turbine blades could be flown to space, remelted to introduce reinforcing composite whiskers and resolidified for return to earth. Electrophoretically separated biological materials have been 5-7 times as pure if produced in space instead of on earth, and may lead to manufacturing Beta cells, pituitary cells, urokinase and interferon. Chief impediments to rapid progress in space commercialization could be the present tax structure, which inhibits high-risk ventures, and industrial ignorance of space manufacturing capabilities. (M.S.K.)

Source of Abstract/Subfile: AIAA/TIS

Descriptors: \*LOW GRAVITY MANUFACTURING; \*SPACE MANUFACTURING; \*SPACE PROCESSING; COST EFFECTIVENESS; CRYSTALS ; DRUGS; MATERIALS RECOVERY; METALLURGY; RESEARCH AND DEVELOPMENT; SPACE INDUSTRIALIZATION; WEIGHTLESSNESS

Subject Classification: 7512 .Astronautics--General (1975-)

1318687 A84-39063

Overview of the industrialization of space

PARDOE, G. K. C. (General Technology Systems, Ltd., Brentford, Middx., England)

(Royal Society, Meeting on the Industrialization of Space, London, England, Dec. 7, 8, 1983) Earth-Oriented Applications of Space Technology (ISSN 0277-4488), vol. 4, no. 2, 1984, p. 65-76.

Publication Date: 1984

Language: English

Country of Origin: United Kingdom Country of Publication: United Kingdom

Document Type: JOURNAL ARTICLE; CONFERENCE PAPER

Most documents available from AIAA Technical Library

Journal Announcement: IAAB418

The present status of space industrialization is reviewed with attention given to the role played by satellites in education, mobile communications on land, navigation, earth observations and meteorology. Space transportation for the injection of satellites into orbit, and more recently the process of recovering them, is shown to be an area of considerable commercial opportunity and projected as an area of vast importance in the future. The recent flight of Spacelab is considered, along with the deployment of SPAS from a Shuttle in September 1983 and its retrieval by the RMS. SPAS and its onboard observation package MOMS is noted to represent

an important operational facility for the future. International industrial collaboration may play an essential role in the consideration of other projects among which the Space Station figures prominently. In conclusion, it is noted that because of its potential for industrialization and extensive commercial activities, space has become an expensive business and there is therefore a need for the interest of nonaerospace industries, particularly in the pharmaceutical sector to get involved. (J.P.)

Source of Abstract/Subfile: AIAA/TIS

Descriptors: \*AEROSPACE SCIENCES; \*SPACE INDUSTRIALIZATION; \*TECHNOLOGY ASSESSMENT; COMMUNICATION SATELLITES; INTERNATIONAL COOPERATION; SPACE TRANSPORTATION SYSTEM; SPACELAB; TECHNOLOGICAL FORECASTING

Subject Classification: 7512 .Astronautics--General (1975-)

## DIALOG File 108: AEROSPACE - 62-86/ISS09

1300776 A84-29866

**International aspects of commercial space activities**  
 PEDERSEN, K. S. (NASA, International Affairs Div.,  
 Washington, DC)  
 National Aeronautics and Space Administration, Washington,  
 D. C.

Corp. Source Code: NC452981

IN: Space manufacturing 1983; Proceedings of the Sixth  
 Conference, Princeton, NJ, May 9-12, 1983 (A84-29852 12-12).  
 San Diego, CA, Univelt, Inc., 1983, p. 209-217.

Publication Date: 1983

Report No.: AAS PAPER 83-222

Language: English

Country of Origin: United States Country of Publication:

United States

Document Type: CONFERENCE PAPER

Most documents available from AIAA Technical Library

Journal Announcement: IAAB412

Attention is given to problems in international cooperation  
 that will arise if NASA proceeds with a Space Station. The  
 rise in space budgets in many countries is cited as an  
 indication of the growing importance being placed on space  
 activities. It is also pointed out that these nations are  
 emphasizing areas which hold promise for eventual commercial  
 payoff. Developing countries are also paying greater attention  
 to space. As part of the European Space Agency's development  
 program, it is underwriting the development of up to six  
 multiuser facilities dedicated to microgravity research; these  
 include furnaces and thermostats for processing metallurgical  
 samples and for crystal growth and botanical investigations.  
 Competition from Europe is seen as a spur to efficiency.  
 Attention is also given to the question whether international  
 cooperation will interfere with research carried out by the US  
 for military purposes. (C.R.)

Source of Abstract/Subfile: AIAA/TIS

Descriptors: +INTERNATIONAL COOPERATION; +NASA PROGRAMS;  
 +SPACE COMMERCIALIZATION; +SPACE PROGRAMS; +SPACE STATIONS;  
 AEROSPACE TECHNOLOGY TRANSFER; EUROPEAN SPACE PROGRAMS;  
 MATERIALS RECOVERY; MILITARY SPACECRAFT; POLICIES; PROJECT  
 MANAGEMENT; SPACE PROCESSING; SPACEBORNE EXPERIMENTS; SPACELAB  
 Subject Classification: 7512 Astronautics--General (1975-)

1300496 A84-29586

**Investigating in space - Now, soon, or later?**

GREY, J. (American Institute of Aeronautics and  
 Astronautics, New York, NY)

Aerospace America (ISSN 0740-722X), vol. 22, April 1984, p.  
 90-92.

Publication Date: Apr. 1984

Language: English

Country of Origin: United States Country of Publication:

United States

Document Type: JOURNAL ARTICLE

Most documents available from AIAA Technical Library

Journal Announcement: IAAB412

Satellite communications and industrial enterprises related

to it are already gaining large revenues, while potential  
 businesses based on space manufacturing, space transportation,  
 navigation, remote sensing, and ground servicing have been  
 identified. Space transportation capacity is currently far  
 greater than demand, and will remain so for at least a decade.

Satellite communications demand is still growing rapidly at  
 between 20 and 30 percent. This market is, however, already  
 being actively developed by major corporations. Real business  
 prospects regarding remote sensing are difficult to quantify  
 and may very well prove to be illusory, at least in the near  
 term. The biggest long-term potential return lies in  
 exploiting the wholly new materials-processing environment  
 created in an orbiting satellite. However, profits are not  
 expected to appear until perhaps 1988 at best. (G.R.)

Source of Abstract/Subfile: AIAA/TIS

Descriptors: +INVESTMENTS; +REMOTE SENSORS; +SATELLITE-BORNE  
 INSTRUMENTS; +SPACE COMMUNICATION; +SPACE MANUFACTURING;  
 +SPACE TRANSPORTATION; FINANCE

Subject Classification: 7512 Astronautics--General (1975-)

1300467 A84-29557

**The 21st century in space**

MUELLER, G. (International Academy of Astronautics, Paris,  
 France)

Aerospace America (ISSN 0740-722X), vol. 22, Jan. 1984, p.  
 84-88.

Publication Date: Jan. 1984

Language: English

Country of Origin: International Organization Country of

Publication: United States

Document Type: JOURNAL ARTICLE

Most documents available from AIAA Technical Library

Journal Announcement: IAAB412

An attempt is made to forecast the space systems scenario of  
 the early 21st century in terms of trends rather than items on  
 a specific timetable, assuming that the militarization of  
 space does not preclude further development of scientific and  
 commercial systems either directly, or indirectly through  
 absorption of government funding. Further assuming that the  
 pertinent legal issues will be resolved, satellite  
 communications beyond the year 2000 will allow beaming to any  
 spot on the globe at very low cost. This communications  
 capability will strongly affect the advertising and  
 distribution of consumer goods. Lunar solar power stations may  
 be able to supply a significant portion of the earth's  
 electrical energy. A second generation Space Shuttle will  
 allow the volume of microgravity environment-processed  
 materials to grow into a major commercial field. The prospects  
 for further searches for extraterrestrial intelligence are  
 noted. (D.C.)

Source of Abstract/Subfile: AIAA/TIS

Descriptors: +SPACE INDUSTRIALIZATION; +TECHNOLOGICAL  
 FORECASTING; ASTEROIDS; COMMUNICATION SATELLITES; LUNAR BASES  
 MINING; SPACE LAW; SPACE MANUFACTURING; SPACE SHUTTLE ORBITERS  
 (cont. next page)

ORIGINAL PART IS  
OF POOR QUALITY

## DIALOG File 108: AEROSPACE - 82-88/ISS09

Subject Classification: 7512 .Astronautics--General (1975-)  
1298855 A84-27945

**Leasecraft - An innovative space vehicle**

DESKEVICH, J. (Fairchild Space Co., Germantown, MD)

IEFE Transactions on Aerospace and Electronic Systems (ISSN 0018-9251), vol. AES-20, Jan. 1984, p. 25-37.

Publication Date: Jan. 1984

Language: English

Country of Origin: United States Country of Publication: United States

Document Type: JOURNAL ARTICLE

Most documents available from AIAA Technical Library

Journal Announcement: IAA8411

The Leasecraft system has been developed by an American aerospace company with the objective to further the industrialization of space with its significant business potential. This system comprises a low orbit space platform, an operation control center, user accommodations, and services such as payload interfaces, documentation, and ground support equipment and procedures. Potential applications of Leasecraft considered are related to the processing of pharmaceuticals and materials; satellite-aided search and rescue, data collection, and support of NASA's astrophysics programs. The Leasecraft space vehicle will accommodate up to five modular power subsystems, including a communications and data handling module, a modular attitude control subsystem, a special function module, two alternative solar array assemblies, a tracking and data relay satellite system antenna assembly, a propulsion module, and optional primary and secondary payload modules. (G.R.)

Source of Abstract/Subfile: AIAA/TIS

Descriptors: +COMMERCIAL SPACECRAFT; +SPACE COMMERCIALIZATION; +SPACE INDUSTRIALIZATION; +SPACE PLATFORMS; +SPACECRAFT DESIGN; COST EFFECTIVENESS; DATA MANAGEMENT; LEASING; ORBITAL SERVICING; SPACE PROCESSING; SPACECRAFT COMMUNICATION; SPACECRAFT MODULES

Subject Classification: 7515 .Launch Vehicles & Space Vehicles (1975-)

1284839 A84-22339

**EOS - Electrophoresis Operations in Space - A promising new era of business in space**

RICHMAN, D. W. (McDonnell Douglas Astronautics Co., St. Louis, MO)

IN: Manufacturing in space; Proceedings of the Winter Annual Meeting, Boston, MA, November 13-18, 1983 (A84-22327 08-12). New York, American Society of Mechanical Engineers, 1983, p. 139-142.

Publication Date: 1983

Language: English

Country of Origin: United States Country of Publication: United States

Document Type: CONFERENCE PAPER

Most documents available from AIAA Technical Library

Journal Announcement: IAA8408

Electrophoresis Operations in Space tested on board the

STS-4 and STS-6 demonstrate improved sample yield and purity for continuous flow electrophoresis. Protein concentration level in zero-gravity is limited only by the solubility of the protein and the carrier fluid. Twenty-five percent protein by weight per unit volume, or 125 times more material than on earth can be separated in space. Due to the absence of gravity-driven convection currents in space, separation chamber thickness could be increased from 1.5 to 3.0 mm and the sample inlet could be enlarged from one-half to one millimeter, permitting a 3.7 times larger sample injection and consequently a 463 times greater separation yield. The addition of a water-cooling system to the separation unit, allowing a 140 V to 400 V increase without affecting cabin temperature, and lengthening the samples electrical field exposure produced four times more purity and separated 700 times more material than obtainable on earth. (C.M.)

Source of Abstract/Subfile: AIAA/TIS

Descriptors: +ELECTROPHORESIS; +ENVIRONMENTAL TESTS; +REDUCED GRAVITY; +SPACE COMMERCIALIZATION; +SPACE PROCESSING SPACE TRANSPORTATION SYSTEM 4 FLIGHT; SPACE TRANSPORTATION SYSTEM 6 FLIGHT; TECHNOLOGICAL FORECASTING

Subject Classification: 7512 .Astronautics--General (1975-)

1284827 A84-22327

**Manufacturing in space; Proceedings of the Winter Annual Meeting, Boston, MA, November 13-18, 1983**

KOPS, L., ED. (McGill University, Montreal, Canada)

Meeting sponsored by the American Society of Mechanical Engineers. New York, American Society of Mechanical Engineers (Production Engineering Symposia Series, PED Volume 11), 1983, 223 p.

Publication Date: 1983

Language: English

Country of Publication: United States

Document Type: CONFERENCE PROCEEDINGS

Journal Announcement: IAA8408

Processes, facilities, and issues related to manufacturing in outer space are addressed. The subjects discussed include: NASA, European, and Japanese projects on materials processing in space; gravitational effects in dendritic growth; space research impact on semiconductor crystal growth technology; simulation prior to space manufacturing; hardware for materials processing in space; containerless science and technologies; a low orbit satellite manufacturing facility; remote manipulators in space; automation, robotics, and machine intelligence systems in space manufacturing. Also considered are: manufacturing space systems in space; electrophoresis operations in space; rationale for commercial activities in space; Space Shuttle, private enterprise, and intellectual properties in space manufacturing; manufacturers' liability for space products; economics and profitability of space manufacturing; and international cooperation and competition in materials processing in space. For individual items see A84-22328 to A84-22346 (C.D.)

(cont. next page)

DIALOG File 108: AEROSPACE - 82-88/ISS09

Source of Abstract/Subfile: AIAA/TIS  
 Descriptors: \*CONFERENCES; \*LOW GRAVITY MANUFACTURING;  
 \*MATERIALS SCIENCE; \*SPACE PROCESSING; CONTAINERLESS MELTS;  
 CRYSTAL GROWTH; EUROPEAN SPACE PROGRAMS; JAPANESE SPACE  
 PROGRAM; NASA PROGRAMS; RESEARCH AND DEVELOPMENT; ROBOTICS;  
 SPACE COMMERCIALIZATION; SPACE INDUSTRIALIZATION; SPACE  
 SHUTTLE PAYLOADS; SPACELAB PAYLOADS; TECHNOLOGY ASSESSMENT;  
 WEIGHTLESSNESS SIMULATION

Subject Classification: 7512 .Astronautics--General (1975-)

1274228 AB4-11728

**Space station - A Canadian perspective**

DOETSCH, K. H. (National Aeronautical Establishment, Ottawa, Canada)

International Astronautical Federation, International Astronautical Congress, 34th, Budapest, Hungary, Oct. 10-15, 1983. 16 p.

Publication Date: Oct. 1983

Report No.: IAF PAPER 83-55

Language: English

Country of Origin: Canada Country of Publication: International Organization

Document Type: PREPRINT

Most documents available from AIAA Technical Library

Journal Announcement: IAA8402

Canada's potential role in the development and operation of a space-station infra-structure is discussed, reporting the results of a survey of industrial, university, and government users and/or suppliers conducted in 1982-1983, in response to a NASA request. Interest is found in applications from the fields of remote sensing, communications, materials processing, science, technology, medicine, and biology; while Canadian industry could contribute to such aspects as space construction and maintenance, large-solar-array design, flexible-structure design and control, and sensor-system development. It is suggested that most Canadian needs can be served by a combination of polar-orbit platforms for remote sensing, a low-inclination, low-earth-orbit, permanently or intermittently manned research and development laboratory, and a local-orbit maneuvering vehicle to assemble and service them. A block diagram of space infrastructures and graphs of the survey responses are provided. (T.K.)

Source of Abstract/Subfile: AIAA/TIS

Descriptors: \*CANADIAN SPACE PROGRAMS; \*MISSION PLANNING;  
 \*SPACE STATIONS; \*USER REQUIREMENTS; METHODOLOGY; POLAR ORBITS  
 ; REMOTE SENSING; SPACE MANUFACTURING; SPACEBORNE EXPERIMENTS

Subject Classification: 7512 .Astronautics--General (1975-)

1269513 N84-15165

**Commercialization of opportunities for materials processing in low gravity**

Final Report

BROWN, W. S.; NIXON, S. R.

Brown (W. S.), Inc., Salt Lake City, Utah.

Corp. Source Code: B1723032

Publication Date: Jun. 1983 35P.

Report No.: NASA-CR-170953; NAS 1.26:170953

Contract No.: NAS8-34901

Language: English

Country of Origin: United States Country of Publication: United States

Document Type: REPORT

Most documents available from AIAA Technical Library

Other Availability: NTIS HC A03/MF A01

Journal Announcement: STAR8406

Business infrastructure required to achieve commercial MPS, incentives and disincentives for MPS, NASA/industry working agreements, small business innovation, NASA/industry agreements, joint venture agreements, and commercial spinoffs are addressed. (Author)

Descriptors: \*LOW GRAVITY MANUFACTURING; \*MANAGEMENT PLANNING; \*SPACE MANUFACTURING; ECONOMIC FACTORS; PRODUCT DEVELOPMENT; TECHNOLOGY UTILIZATION

Subject Classification: 7512 .Astronautics--General (1975-)

COSATI Code: 22A .Astronautics

1261958 AB3-47820

**Push to commercialize space runs into budget cutbacks, boondoggle charges, and fear of high risks**

KINNUCAN, P.

High Technology (ISSN 0277-2981), vol. 3, Oct. 1983, p. 43-45, 48-51.

Publication Date: Oct. 1983

Language: English

Country of Publication: United States

Document Type: JOURNAL ARTICLE

Most documents available from AIAA Technical Library

Journal Announcement: IAA8323

Government attempts to increase the participation of private enterprise in the commercialization of space are explored. The electrophoresis experiments on the Shuttle have progressed sufficiently far for the sponsoring company to schedule one of its own employees for a flight, as well as clinical testing of the product. Government policy aimed at encouraging private sector participation is in line with the concept that competition and the profit motive produce better service at a lower price. Propositions to transfer the Landsat and Metsat systems to private concerns have failed to lead to swift action. Similarly, leasing launch rights to expendable boosters has been inhibited by the presence of direct competition with government subsidized launch services like the Shuttle and the Ariane. Industrialists have encouraged the government-supported development of a space station and unmanned, reusable launch vehicles that are less costly than the Shuttle. NASA, meanwhile, is entering into joint development contracts with industries for experimenting with prototype production systems, e.g., the electrophoretic pharmaceuticals and GaAs semiconductors grown in space. (M.S.K.)

(cont. next page)

ORIGINAL PAGE IS  
OF POOR QUALITY

## DIALOG File 108: AEROSPACE - 82-88/ISS09

Source of Abstract/Subfile: AIAA/TIS  
 Descriptors: \*ECONOMIC FACTORS; \*GOVERNMENT/INDUSTRY  
 RELATIONS; \*LAUNCH VEHICLES; \*SPACE INDUSTRIALIZATION; \*SPACE  
 MANUFACTURING; ORBIT TRANSFER VEHICLES; ORBITAL SPACE STATIONS  
 ; SPACE TRANSPORTATION SYSTEM; SPACEBORNE EXPERIMENTS  
 Subject Classification: 7583 .Economics & Cost Analysis  
 (1975-)

1259230 A83-45091

The world in space: A survey of space activities and issues  
 (Book)

CHIPMAN, R., ED.  
 Englewood Cliffs, NJ, Prentice-Hall, Inc., 1982, 701 p.  
 Publication Date: 1982  
 Language: English  
 Country of Publication: United States  
 Document Type: COLLECTED WORK  
 Journal Announcement: IAA8321

Materials presented at the UNISPACE 82 conference are provided. The current state of space science is summarized and discoveries in the future are projected, including geoscience and materials processing experiments in near-earth space. The support technologies in existence and necessary for an expansion of space capabilities are described, and the relevance of space missions for monitoring earth resources and the environment is discussed. The physical impact of space activities on the atmosphere, human life, the orbital environment, and on astronomical observations is assessed. Attention is devoted to the compatibility and complementarity of meteorological, communications, and remote sensing satellite systems, and to the feasibility of using satellites for educational purposes. Efficiency in geostationary orbit use is considered, as are the social and economic aspects of space technology, with note taken of the relevance to developing nations. Finally, international cooperation in space is explored in terms of roles of intergovernmental, United Nations, and nongovernmental organizations in space activities. No individual items are abstracted in this volume (M.S.K.)

Source of Abstract/Subfile: AIAA/TIS  
 Descriptors: \*AEROSPACE SCIENCES; \*SPACE EXPLORATION;  
 \*TECHNOLOGY UTILIZATION; \*UNITED NATIONS; ARTIFICIAL  
 SATELLITES; ASTRONOMY; COMMUNICATION SATELLITES; ECONOMIC  
 DEVELOPMENT; ENVIRONMENT EFFECTS; GEOSYNCHRONOUS ORBITS;  
 INTERNATIONAL COOPERATION; ORBIT SPECTRUM UTILIZATION; REMOTE  
 SENSING; SATELLITE OBSERVATION; SPACE MANUFACTURING  
 Subject Classification: 7512 .Astronautics--General (1975-)

1229808 A83-15663

Space industrialization - An international perspective

MAYUR, R. (Futurology Commission, Bombay, India)  
 In: International Scientific Conference on Space, 22nd,  
 Rome, Italy, March 25, 26, 1982, Proceedings. (A83-15655  
 04-12) Rome, Rassegna Internazionale Elettronica Nucleare ed  
 Aerospaziale, 1982, p. 107-115.

Publication Date: 1982  
 Language: English  
 Country of Origin: India Country of Publication: Italy  
 Document Type: CONFERENCE PAPER  
 Journal Announcement: IAA8304

The impacts and areas of application of emerging space technologies on the earth's nations and populations are discussed. Space exploration and exploitation are noted to have added a third force of change on human society, the others being the formation of populous cities and the numbers and diversities of manufactured products due to the Industrial Revolution. Space industrialization is seen as an inexorable step following the development of automation, which demands thorough cost-benefit analyses before undertaking any new initiatives in space. Industrialized countries are predicted to benefit in areas of medicine, tourism, new products, electronic mail, and electronics during the near term from space activities, while lesser developed countries will gain advantages in agriculture and education. The entire world will experience gains in energy, communications, transportation, disaster prevention, environmental monitoring, materials processing, resource assessments, and the development of new materials. (M.S.K.)

Source of Abstract/Subfile: AIAA/TIS  
 Descriptors: \*SPACE INDUSTRIALIZATION; \*SPACE PROGRAMS;  
 \*TECHNOLOGY UTILIZATION; AGRICULTURE; DISASTERS; EDUCATION;  
 MEDICINE; SOLAR POWER SATELLITES; TELECOMMUNICATION  
 Subject Classification: 7512 .Astronautics--General (1975-)

1218736 N83-31640

Japanese program review of material processing in space  
 SAWAOKA, A.

Tokyo Inst. of Tech. (Japan).  
 Corp. Source Code: T1204219

In ESA Mater. Sci. under Microgravity p 23-27 (SEE N83-31637  
 20-12)

Publication Date: Jun. 1983  
 Language: English  
 Country of Origin: Japan Country of Publication:  
 International Organization

Document Type: CONFERENCE PAPER  
 Most documents available from AIAA Technical Library  
 Other Availability: NTIS HC A19/MF AO1; ESA, Paris FF 140  
 Journal Announcement: STAR8320

Ground based simulations of material processing in space, the specifications of the TT 500A rocket for material processing experiments, Japanese participation in the Spacelab program, and research into the creation of materials in microgravity are outlined. The TT 500A electric furnaces can heat a 35 mm x 10 mm sample to 1500 C within 2 min and cool it from 1500 to 800 C in 2 min, with + or - 50 C accuracy. (Author (ESA))

Source of Abstract/Subfile: ESA  
 Descriptors: \*JAPANESE SPACE PROGRAM; \*SPACE MANUFACTURING;  
 (cont. next page)

ORIGINAL PAGE IS  
OF POOR QUALITY

DIALOG File 108: AEROSPACE - 62-86/ISS09

\*SPACELAB; \*WEIGHTLESSNESS SIMULATION; FURNACES; MATERIALS  
SCIENCE; ROCKET-BORNE INSTRUMENTS; SPACE ENVIRONMENT  
SIMULATION; SPACELAB PAYLOADS

Subject Classification: 7512 .Astronautics--General (1975-)

1182214 N82-19236

Manufacturing in space: Fluid dynamics numerical analysis

Annual Report, Aug. 1980 - Aug. 1981

ROBERTSON, S. J.; NICHOLSON, L. A.; SPRADLEY, L. W.

Lockheed Missiles and Space Co., Huntsville, Ala.

Corp. Source Code: L1340457

Publication Date: Aug. 1981 5IP.

Report No.: NASA-CR-168610; LMSC-HREC-TR-D784480

Contract No.: NASW-3281

Language: English

Country of Origin: United States Country of Publication:

United States

Document Type: REPORT

Most documents available from AIAA Technical Library

Other Availability: NTIS HC A04/MF A01

Journal Announcement: STAR8210

Natural convection in a spherical container with cooling at the center was numerically simulated using the Lockheed-developed General Interpolants Method (GIM) numerical fluid dynamic computer program. The numerical analysis was simplified by assuming axisymmetric flow in the spherical container, with the symmetry axis being a sphere diagonal parallel to the gravity vector. This axisymmetric spherical geometry was intended as an idealization of the proposed Lal/Kroes growing experiments to be performed on board Spacelab. Results were obtained for a range of Rayleigh numbers from 25 to 10,000. For a temperature difference of 10 C from the cooling sting at the center to the container surface, and a gravitational loading of 0.000001 g a computed maximum fluid velocity of about  $2.4 \times 0.00001$  cm/sec was reached after about 250 sec. The computed velocities were found to be approximately proportional to the Rayleigh number over the range of Rayleigh numbers investigated. (Author)

Descriptors: \*COMPUTATIONAL FLUID DYNAMICS; \*COMPUTER PROGRAMS; \*COMPUTERIZED SIMULATION; \*CRYSTAL GROWTH; \*SPACE MANUFACTURING; AXISYMMETRIC FLOW; CIRCULAR CYLINDERS; CONVECTION; COOLING; FLOW VELOCITY; GRAVITATION; RAYLEIGH NUMBER; SPACELAB

Subject Classification: 7512 .Astronautics--General (1975-)

COSATI Code: 22A .Astronautics

1172016 A82-47267

The potential scope of space manufacturing

WALTZ, D. M. (TRW Space and Technology Group, Redondo Beach, CA)

In: Making space work for mankind; Proceedings of the Nineteenth Space Congress, Cocoa Beach, FL, April 28-30, 1982. (A82-47251 24-12) Cape Canaveral, FL, Canaveral Council of Technical Societies, 1982, p. 5-1 to 5-11.

Publication Date: 1982 21 Refs.

Language: English

Country of Origin: United States Country of Publication: United States

Document Type: CONFERENCE PAPER

Journal Announcement: IAA8224

Space manufacturing is defined, and potential processes and product types are discussed. Five basic processes are involved, including crystal growth, purification/separation, mixing, solidification, and processes in fluids. A three-phase timetable for the space manufacturing is described, and major issues and considerations that apply to various points of the timetable are addressed, including the products and services most likely to be exploited, the assessment of user charges, and the handling of proprietary data. It is concluded that pharmaceuticals, electronic devices, optical products, and advanced alloys seem to hold the most promise for space manufacturing. (C.D.)

Source of Abstract/Subfile: AIAA/TIS

Descriptors: \*MARKET RESEARCH; \*SPACE MANUFACTURING; \*TECHNOLOGY ASSESSMENT; ALLOYS; ELECTRONIC EQUIPMENT; OPTICAL EQUIPMENT; SPACE PROCESSING; USER REQUIREMENTS

Subject Classification: 7512 .Astronautics--General (1975-)

1171972 A82-47223

Space factories a long way off

WATTS, C.

High Technology, vol. 2, Nov.-Dec. 1982, p. 23, 25, 26.

Publication Date: Dec. 1982

Language: English

Country of Publication: United States

Document Type: JOURNAL ARTICLE

Most documents available from AIAA Technical Library

Journal Announcement: IAA8224

Experimentation and prospects of materials processing on-board the Shuttle as a prelude to future space manufacturing facilities are assessed. Space-based research into specific heats, diffusivity, surface tension, and viscosity has applications in earth-based industry, although the related products cannot be more effectively made in orbit.

Biological experimentation is promising due to the contamination-free, near vacuum conditions in space. Continuous flow electrophoresis is unhindered by gravitational effects in space, and Shuttle experiments have demonstrated separation of six proteins producing purities of 40%, while the same process on earth would yield 0.1% purity. The absence of convection and gravitational effects is partially offset by the presence of Marangoni convection in liquids. Finally, use of a wake-shield extended by a boom from the side of the Orbiter to carry out experimentation in ultrahigh vacuum conditions is described, as is the development of a 200-lb furnace with 37 compartments for testing alloy resolidification on board the Orbiter. (M.S.K.)

Source of Abstract/Subfile: AIAA/TIS

Descriptors: \*MATERIALS SCIENCE; \*SPACE INDUSTRIALIZATION; (cont. next page)



## DIALOG File 108: AEROSPACE - 62-88/ISS09

\*SPACE MANUFACTURING; \*SPACE SHUTTLE ORBITERS; \*SPACEBORNE EXPERIMENTS; ELECTROPHORESIS; EXO BIOLOGY; GRAVITATIONAL EFFECTS; RECRYSTALLIZATION

Subject Classification: 7512 .Astronautics--General (1975-)

1166190 A82-41441

**Certain problems in space manufacturing**

Nekotorye voprosy kosmicheskoi tekhnologii

KIPARISOV, S. S.

Srpska Akademija Nauka i Umetnosti, Posebna Izdanja, no. 529, Odelenje Tehnichkih Nauka, no. 20, 1980. 22 p. In Russian.

Publication Date: 1980 17 Refs.

Language: Russian

Country of Publication: Yugoslavia

Document Type: JOURNAL ARTICLE

Most documents available from AIAA Technical Library

Journal Announcement: IAAB220

Various aspects of space manufacturing are discussed, including the use of the Bridgman furnace, powder-metallurgical processes, crystal growth and volume crystallization in a universal furnace during the Morava experiment, and the Sirena experiment on Salyut-6-Soyuz. The conducting of biomedical experiments in space is discussed, and the repair and maintenance of space stations is considered. (B.J.)

Source of Abstract/Subfile: AIAA/TIS

Descriptors: \*ORBITAL SPACE STATIONS; \*SOVIET SPACECRAFT; \*SPACE MAINTENANCE; \*SPACE MANUFACTURING; \*SPACEBORNE EXPERIMENTS; BRIDGMAN METHOD; COMPOSITE MATERIALS; CRYSTAL GROWTH; EXO BIOLOGY; LONG DURATION SPACE FLIGHT; METALLURGY

Subject Classification: 7512 .Astronautics--General (1975-)

1160350 A82-35601

**Space manufacturing 4; Proceedings of the Fifth Conference, Princeton University, Princeton, NJ, May 18-21, 1981**

GREY, J. (ED.) (American Institute of Aeronautics and Astronautics, New York, NY); HAMDAN, L. A.

Conference sponsored by Princeton University and American Institute of Aeronautics and Astronautics, New York, American Institute of Aeronautics and Astronautics, 1981. 464 p. (For individual items see A82-35602 to A82-35641)

Publication Date: 1981

Language: English

Country of Publication: United States

Document Type: CONFERENCE PROCEEDINGS

Journal Announcement: IAAB217

Space manufacturing is discussed in regard to international and legal considerations, social sciences, novel concepts, materials resources and processing, and space stations and habitats. Particular topics discussed include the military implications of a satellite power system; a self-replicating, growing lunar factory; the supply of lunar oxygen to low earth orbit; a small-scale lunar launcher for early lunar material utilization; a decision-analytic evaluation of the SPS

program; powder metallurgy in space manufacturing; and United States and Soviet life sciences factors in long-duration space flight. (B.J.)

Source of Abstract/Subfile: AIAA/TIS

Descriptors: \*CONFERENCES; \*SPACE MANUFACTURING; ELECTROMAGNETIC ACCELERATION; HUMAN BEHAVIOR; INTERNATIONAL COOPERATION; INTERNATIONAL LAW; LARGE SPACE STRUCTURES; LAUNCHERS; LIFE SCIENCES; LUNAR SOIL; MASS DRIVERS (PAYLOAD DELIVERY); POLICIES; POLITICS; POWDER METALLURGY; SOLAR POWER SATELLITES; SPACE LAW; SPACE STATIONS

Subject Classification: 7512 .Astronautics--General (1975-)

1152576 A82-27827

**Legal implications of commercial space activities**

BOECKSTIEGEL, K.-H. (Koeln, Universitaet, Cologne, West Germany)

In: Colloquium on the Law of Outer Space, 24th, Rome, Italy, September 6-12, 1981. Proceedings. (A82-27826 12-84) New York, American Institute of Aeronautics and Astronautics, 1982. p. 1-17.

Publication Date: 1982 49 Refs.

Report No.: IAF 81-SL-02

Language: English

Country of Origin: Germany, Federal Republic of Country of

Publication: United States

Document Type: CONFERENCE PAPER

Journal Announcement: IAAB212

The transition from exploration to commercial exploitation of space and space technology is considered in terms of legal issues defined by international and national laws, the Outer Space Treaty and the Moon Treaty, and liability and regulatory topics. The shift of emphasis of government funding for the Shuttle is regarded as encouraging early commercial use for Shuttle-launched materials processing in space. Communications and earth resources satellites have already begun showing commercial success, and resources assessment from space offers an aid to developing nations in need of mineral and energy sources. Legal issues are projected to include the delineation of the boundaries of outer space, GEO, the legal definition of space transportation systems, the access of states, institutions, and enterprises to natural resources in celestial bodies, and the transfer of space technology. (Author))

Descriptors: \*INTERNATIONAL RELATIONS; \*LEGAL LIABILITY; \*SPACE INDUSTRIALIZATION; \*SPACE LAW; \*SPACE PROCESSING; ECONOMIC FACTORS; INTERNATIONAL LAW; OUTER SPACE TREATY; SPACE TRANSPORTATION SYSTEM; TECHNOLOGY TRANSFER

Subject Classification: 7584 .Law & Political Science (1975-)

## DIALOG File 108: AEROSPACE - 62-88/ISS09

1144500 A82-19750

**Engineers gain a platform in space**

JOYCE, C.

New Scientist, vol. 92, Dec. 17, 1981, p. 812, 813.

Publication Date: Dec. 1981

Language: English

Country of Publication: United Kingdom

Document Type: JOURNAL ARTICLE

Most documents available from AIAA Technical Library

Journal Announcement: IAAB207

The characteristics and applications of the Multimission Modular Spacecraft (MMS) are discussed. The MMS is designed specifically for launch by the Shuttle, and comprises a three-sided steel frame housing communications, attitude control, data handling, and an on-board power supply. An extra propulsion module can be fitted to the bottom of the frame for boost to different orbits, and the top of the frame has a circular ring to which specific payloads can be affixed. The MMS can be borne into orbit with scientific or military payloads by the Shuttle and later retrieved, returned to earth, and fitted with another payload. The modules can also be detached, repaired, or replaced in space by simple, standardized procedures. The use of the MMS as the base for space factories, such as for electrophoresis to produce beta cells, interferon, and the enzyme alpha-trypsin are discussed, along with a possible rescue mission by the Shuttle to retrieve or repair the first MMS, the Solar Maximum Mission, which has experienced a number of instrument malfunctions. (M.S.K.)

Source of Abstract/Subfile: AIAA/TIS

Descriptors: \*MULTIMISSION MODULAR SPACECRAFT; \*NASA PROGRAMS; \*REUSABLE SPACECRAFT; \*SPACE MANUFACTURING; \*SPACE PLATFORMS; INSTRUMENT PACKAGES; MILITARY SPACECRAFT; RESCUE OPERATIONS; SCIENTIFIC SATELLITES; SPACE SHUTTLES; STEEL STRUCTURES

Subject Classification: 7515 Launch Vehicles & Space Vehicles (1975-)

1142077 A82-17327

**Space Shuttle - A new era in transportation**

DUNBAR, B. J. (NASA, Johnson Space Center, Houston, TX)

National Aeronautics and Space Administration, Lyndon B.

Johnson Space Center, Houston, Tex.

Corp. Source Code: ND052615

American Ceramic Society Bulletin, vol. 60, Nov. 1981, p.

1180-1187.

Publication Date: Nov. 1981 26 Refs.

Language: English

Country of Origin: United States Country of Publication: United States

Document Type: JOURNAL ARTICLE

Most documents available from AIAA Technical Library

Journal Announcement: IAAB205

After a brief historical review of the economics of expendable-booster, commercial-payload operations to date, and a description of the Space Shuttle system's design,

operational capabilities, and mission profile, the payload flight assignments, materials processing experiments, and Spacelab I material science experiment are detailed. Among the Materials Processing in Space (MPS) fields for investigation are crystal growth from vapor and solution, the production of magnetic composites and metal foams, laser host glasses and metallic glasses, non-buoyancy-driven convections, unidirectional solidification of eutectics, and the solidification of immiscible alloys. Emphasis is put on the long-term, commercial usefulness of such studies, with attention to historical precedents such as the Skylab, Apollo and Apollo-Soyuz programs. (O.C.)

Source of Abstract/Subfile: AIAA/TIS

Descriptors: \*SPACE PROCESSING; \*SPACE SHUTTLES; \*SPACE TRANSPORTATION; \*SPACECRAFT DESIGN; \*SPACELAB PAYLOADS; CERAMICS; CRYSTAL GROWTH; EUTECTIC ALLOYS; SKYLAB PROGRAM; SPACE INDUSTRIALIZATION; SPACE SHUTTLE ORBITERS; SPACE SHUTTLE PAYLOADS

Subject Classification: 7516 Space Transportation (1975-)

1140608 A82-15858

**Economic factors of outer space production**

MILLER, B. P. (ECON, Inc., Princeton, NJ)

In: Human factors of outer space production. (A82-15851 04-54) Boulder, CO, Westview Press, Inc., 1980, p. 179-206.

Publication Date: 1980 17 Refs.

Language: English

Country of Origin: United States Country of Publication: United States

Document Type: ANALYTIC OF COLLECTED WORK

Journal Announcement: IAAB204

Issues affecting space-based production of goods and services for earth based use are discussed. Research, development, and operations define the technical phases leading to production, and fields open to space processing are listed as earth observations, communications, materials processing (high value-to-mass ratios), and energy beaming. It is noted that space activities which have entered an operations phase do so at a cost and quality which is superior to the same service rendered from earth-based facilities. The possibilities for a utility type institution to handle Shuttle traffic as a replacement for NASA are considered, and additional fields of outer space enterprises such as earth resources management, land mobile communications systems, and applications for a worldwide emergency communications network are explored. (M.S.K.)

Source of Abstract/Subfile: AIAA/TIS

Descriptors: \*ECONOMIC FACTORS; \*LOW GRAVITY MANUFACTURING; \*RESEARCH AND DEVELOPMENT; \*SPACE INDUSTRIALIZATION; \*SPACE MANUFACTURING; \*SPACE TRANSPORTATION; COST EFFECTIVENESS; DATA COLLECTION PLATFORMS; DATA PROCESSING; DATA TRANSMISSION; RESOURCES MANAGEMENT

Subject Classification: 7583 Economics &amp; Cost Analysis (1975-)

ORIGINAL PAGE IS  
OF POOR QUALITY

DIALOG File 108: AEROSPACE - 62-86/ISS09

1134823 A82-10073

**Working on the moon**

CRISWELL, D.; MARSH, P.

New Scientist, vol. 92, Oct. 1, 1981, p. 30-33.

Publication Date: Oct. 1981

Language: English

Country of Publication: United Kingdom

Document Type: JOURNAL ARTICLE

Most documents available from AIAA Technical Library

Journal Announcement: IAAB201

The construction of factories making use of lunar materials on the surface of the moon is discussed. Advantages of, on the one hand, the use of extraterrestrial materials for manufacturing and, on the other, the low gravity and abundant solar energy of space for materials processing operations are pointed out, and it is noted that initially, such factories making use of lunar materials would be located in earth orbit.

The ultimate transfer of orbiting space factories to the lunar surface is considered, and the types of manufacturing processes that would be suitable for use on the moon are examined, including hydrofluoric acid leaching and electrophoresis as separation techniques, and powder materials processing for metals and ceramics. Consideration is also given to the self-replication of automated lunar factories resembling the proposed space operations center, and to NASA plans for materials processing experiments on the Shuttle, which have suffered significant budget decreases. Finally, the use of lunar-products on the moon and in earth orbit, and for the exploration of the further reaches of space is considered. (A.L.W.)

Source of Abstract/Subfile: AIAA/TIS

Descriptors: \*EXTRATERRESTRIAL RESOURCES; \*LUNAR BASES; \*MOON; \*SPACE MANUFACTURING; AUTOMATION; ELECTROPHORESIS; HYDROFLUORIC ACID; LEACHING; SPACE PROCESSING

Subject Classification: 7512 .Astronautics--General (1975-)

1110504 A81-49670

**Implications of the Shuttle - Our business in space**

GREY, J. (American Institute of Aeronautics and Astronautics, New York, NY)

Technology Review, vol. 84, Oct. 1981, p. 34-36, 38-40, 42, 44, 46.

Publication Date: Oct. 1981

Language: English

Country of Origin: United States Country of Publication: United States

Document Type: JOURNAL ARTICLE

Most documents available from AIAA Technical Library

Journal Announcement: IAAB124

A summary is given of the advantages that the large cargo bay of the Space Shuttle will offer. Also discussed are four space-manufacturing activities deemed especially promising: pharmaceuticals, electronic devices, glass products, and advanced alloys. It is noted that the weightlessness of space eliminates the need for containers, a major source of impurities and surface irregularities in manufacturing. The

fact that the commercial development of space requires few scientific breakthroughs - only a great deal of engineering - to establish technical, economic, and environmental variability is stressed. (C.R.)

Source of Abstract/Subfile: AIAA/TIS

Descriptors: \*LOW GRAVITY MANUFACTURING; \*SPACE MANUFACTURING; \*SPACE PROCESSING; \*SPACE SHUTTLE PAYLOADS; \*WEIGHTLESSNESS; ALLOYS; ECONOMIC FACTORS; GLASS; IMPURITIES; NASA PROGRAMS; PHARMACOLOGY; SPACECRAFT ELECTRONIC EQUIPMENT; VARIABILITY

Subject Classification: 7512 .Astronautics--General (1975-)

1108114 A81-47280

**The capture of lunar materials in low lunar orbit**

FLOYD, M. A. (MIT, Cambridge, MA)

Massachusetts Inst. of Tech., Cambridge.

Corp. Source Code: MJ700802

International Astronautical Federation, International Astronautical Congress, 32nd, Rome, Italy, Sept. 6-12, 1981, 18 p.

Publication Date: Sep. 1981

Report No.: IAF PAPER 81-ST-12

Contract No.: NAGW-21

Language: English

Country of Origin: United States Country of Publication: International Organization

Document Type: CONFERENCE PAPER

Most documents available from AIAA Technical Library

Journal Announcement: IAAB123

A scenario is presented for the retrieval of lunar materials sent into lunar orbit to be used as raw materials in space manufacturing operations. The proposal is based on the launch of material from the lunar surface by an electromagnetic mass driver and the capture of this material in low lunar orbit by a fleet of mass catchers which ferry the material to processing facilities when full. Material trajectories are analyzed using the two-body equations of motion, and intercept requirements and the sensitivity of the system to launch errors are determined. The present scenario is shown to be superior to scenarios that place a single mass catcher at the L2 libration point due to increased operations flexibility, decreased mass driver performance requirements and centralized catcher servicing. (A.L.W.)

Source of Abstract/Subfile: AIAA/TIS

Descriptors: \*CATCHERS; \*LUNAR ORBITS; \*MASS DRIVERS (PAYLOAD DELIVERY); \*MATERIALS HANDLING; \*SPACE PROCESSING; \*TRAJECTORY ANALYSIS; CAPTURE EFFECT; ECONOMIC ANALYSIS; EQUATIONS OF MOTION; ORBITAL ELEMENTS; ORBITAL LAUNCHING; SPACE MANUFACTURING

Subject Classification: 7512 .Astronautics--General (1975-)

## DIALOG File 108: AEROSPACE - 62-86/ISS09

establishing legal and management mechanisms to share cost and risk of early commercial ventures. (D.L.G.)

Source of Abstract/Subfile: AIAA/TIS  
 Descriptors: \*AEROSPACE ENVIRONMENTS; \*LOW GRAVITY MANUFACTURING; \*NASA PROGRAMS; \*SPACE INDUSTRIALIZATION; \*SPACE PROCESSING; COST INCENTIVES; CRYSTAL GROWTH; DIRECTIONAL SOLIDIFICATION (CRYSTALS); ECONOMIC FACTORS; PRODUCT DEVELOPMENT; TECHNOLOGY ASSESSMENT  
 Subject Classification: 7512 .Astronautics--General (1975-)

1094373 A81-33539

Materials Experiment Carrier - An approach to expanded space processing capability

TAYLOR, K. R. (NASA, Marshall Space Flight Center, Huntsville, Ala.); MEISSINGER, H. F.; WALTZ, D. M. (TRW Defense and Space Systems Group, Redondo Beach, Calif.)

National Aeronautics and Space Administration, Marshall Space Flight Center, Huntsville, Ala.

Corp. Source Code: ND736801

American Astronautical Society and American Institute of Aeronautics and Astronautics, Annual Meeting on Space Enhancing Technological Leadership, Boston, Mass., Oct. 20-23, 1980, AAS 27 p.

Publication Date: Oct. 1980 14 Refs.

Report No.: AAS PAPER 80-249

Contract No.: NAS8-33688

Language: English

Country of Origin: United States Country of Publication: United States

Document Type: CONFERENCE PAPER

Most documents available from AIAA Technical Library

Journal Announcement: IAA8114

Conceptual design studies and mission analyses within the NASA Materials Processing in Space (MPS) program of the Materials Experiment Carrier (MEC) approach to conducting near-term as well as future free-flying experiments in materials processing in space are discussed. The experimental background of the MPS program is reviewed, and it is pointed out that the use of the MEC coupled with the 25-kW power system can provide an order-of-magnitude cost savings over conventional Shuttle-based systems, as well as increased orbital stay time and microgravity stability. The determination of the physical and engineering requirements for future MEC scientific/commercial candidate payloads is then discussed, and two proposed candidates for the MEC configuration, which is intended to be a self-contained, general-purpose, versatile and reusable carrier, are illustrated. Possible MEC operations are considered, including mission profiles, deployment sequences, on-orbit payload/sample change-out, optimal power system utilization, the use of real-time, ground-based control and advanced automatic payload operation. Areas in which technology development could benefit the MEC project are also identified. (S.C.S.)

Source of Abstract/Subfile: AIAA/TIS

Descriptors: \*SPACE MISSIONS; \*SPACE PROCESSING; \*SPACE

SHUTTLE PAYLOADS; \*SYSTEMS ENGINEERING; COMPOSITE MATERIALS; COST ANALYSIS; GROUND SUPPORT SYSTEMS; PAYLOAD DEPLOYMENT & RETRIEVAL SYSTEM; SPACE INDUSTRIALIZATION; TECHNOLOGY UTILIZATION

Subject Classification: 7512 .Astronautics--General (1975-)

1093751 A81-32917

Is there business in space - Outlook for commercial space materials processing

WALTZ, D. M. (TRW, Inc., Redondo Beach, Calif.)

American Institute of Aeronautics and Astronautics, Annual Meeting and Technical Display on Frontiers of Achievement, Long Beach, Calif., May 12-14, 1981, 11 p.

Publication Date: May 1981 19 Refs.

Report No.: AIAA PAPER 81-0891

Language: English

Country of Origin: United States Country of Publication: United States

Document Type: CONFERENCE PAPER

Most documents available from AIAA Technical Library

Journal Announcement: IAA8114

Wide consideration is given the range of technological and economic factors affecting the planning and implementation of commercial Materials Processing in Space (MPS). Emphasis is put on the early, 1986-95 research and development period, during which will be conducted the research necessary to identify economically attractive space-based processing concepts and products for 1995 and beyond. Among the topics discussed are: MPS user motivation, business and legal aspects of MPS, government funding, the roles to be played by government and the aerospace and commercial industries. MPS programs in the Soviet Union, West Germany, France and Japan, suggested incentives for MPS commercialization, and the promotional work of NASA's Commercial Applications Office. A list of companies actively investigating the possibilities of MPS is given, along with their concerns about risk capital, proprietary rights to data, and patent rights in the course of collaboration with a federal agency like NASA. (O.C.)

Source of Abstract/Subfile: AIAA/TIS

Descriptors: \*COMPOSITE MATERIALS; \*LOW GRAVITY MANUFACTURING; \*SEMICONDUCTORS (MATERIALS); \*SPACE PROCESSING; \*SPACE SHUTTLE PAYLOADS; \*TECHNOLOGY ASSESSMENT; ALLOYS; ECONOMIC ANALYSIS; LONG TERM EFFECTS; MAGNETIC MATERIALS; MATERIALS SCIENCE; SPACE INDUSTRIALIZATION; TECHNOLOGICAL FORECASTING; U.S.S.R. SPACE PROGRAM

Subject Classification: 7583 .Economics & Cost Analysis (1975-)

1072185 A81-11351

Hardhats in space

HAISE, F. W., JR. (Grumman Aerospace Corp., Bethpage, N.Y.)

Grumman Aerospace Horizons, vol. 16, no. 1, 1980, p. 8-15.

Publication Date: 1980

(cont. next page)

## DIALOG File 108: AEROSPACE - 62-88/ISS09

Language: English  
Country of Origin: United States Country of Publication:  
United States

Document Type: JOURNAL ARTICLE

Most documents available from AIAA Technical Library

Journal Announcement: IAAB101

Methods and materials for constructing space satellite projects are discussed. By the end of the century, workers in space should be able to assemble structures weighing up to millions of earth pounds. Stations could be constructed to produce pharmaceuticals and other items, which are impossible to manufacture on earth. A space shuttle orbiter with a cargo bay 15 ft in diameter and 60 ft long could carry a payload of more than 32 tons and support a crew in orbit for a week in the initial stages of construction. A full-scale machine has been developed that fabricates a triangular one meter structural beam of varying lengths, which could serve as the framework for an orbiting antenna satellite. Space workers would be assisted in assembly work or repair jobs by manned remote work stations, known as open and closed cherry-pickers. Plans for a solar satellite that is 12 miles long and 3 miles wide and which could deliver 5,000 megawatts into the electric power grid on earth are also discussed. (R.C.)

Source of Abstract/Subfile: AIAA/TIS

Descriptors: \*AEROSPACE ENGINEERING; \*ORBITAL ASSEMBLY; \*RESEARCH AND DEVELOPMENT; \*SPACE ERECTABLE STRUCTURES; \*SPACE STATIONS; AEROSPACE ENVIRONMENTS; BEAMS (SUPPORTS); PHARMACOLOGY; SATELLITE ANTENNAS; SOLAR POWER SATELLITES; SPACE INDUSTRIALIZATION; SPACE MAINTENANCE; SPACE SHUTTLE ORBITERS; SPACECREWS

Subject Classification: 7512 .Astronautics--General (1975-)

1052917 N80-16074

Manufacturing in space. Citations from the International Aerospace Abstracts data base (bibliographies)

Progress Report, 1976 - Oct. 1979

ZOLLARS, G. F.

New Mexico Univ., Albuquerque. Technology Application Center.

Corp. Source Code: NY157629

Publication Date: Oct. 1979 86P.

Publication Note: Sponsored by NTIS

Report No.: NTIS/PS-79/1053/2

Language: English

Country of Origin: United States Country of Publication:  
United States

Document Type: OTHER

Most documents available from AIAA Technical Library

Other Availability: NTIS

Journal Announcement: STAR8007

Articles from worldwide literature concerning manufacturing in space are presented. The effects of weightlessness on a variety of manufacturing processes such as crystal growth, welding, zone melting, casting, and the construction of structures are highlighted. Articles concerning materials science research in the European Spacelab program are

included. Three hundred and thirty three citations are included. (GRA)

Descriptors: \*AEROSPACE ENVIRONMENTS; \*BIBLIOGRAPHIES;

\*SPACE MANUFACTURING; CRYSTAL GROWTH; SPACE LABORATORIES;

SPACE PROCESSING; WEIGHTLESSNESS

Subject Classification: 7512 .Astronautics--General (1975-)

COSATI Code: 13H .Industrial Processes

1049978 N80-13125

The near-term potential of manufacturing in space

FRITTS, E.; BYROADE, A.

General Accounting Office, Washington, D. C.

Corp. Source Code: GB268442

In ESA Mater. Sci. in Space p 427-432 (SEE N80-13069 04-12)

Publication Date: Jun. 1979

Language: English

Country of Origin: United States Country of Publication:  
International Organization

Document Type: CONFERENCE PAPER

Most documents available from AIAA Technical Library

Other Availability: NTIS HC A20/MF A01; ESA, Paris FF 120

Journal Announcement: STAR8004

The near-term potential of space manufacturing is discussed. Near-term is defined as anytime between now and the year 2000. In response to that request, an overview of the National Aeronautics and Space Administration's materials processing program, a first step toward space manufacturing, is provided. It is presented in nontechnical terms. The views given represent the perspectives of 52 American scientists, economists, and industrialists who contributed to the study. Problems and obstacles that stand in the way of progress are identified, and some alternative courses of action are offered. (Author (ESA))

Source of Abstract/Subfile: ESA

Descriptors: \*COST EFFECTIVENESS; \*SPACE MANUFACTURING;

\*TECHNOLOGY ASSESSMENT; APPROPRIATIONS; COST ESTIMATES;

FEASIBILITY ANALYSIS; RESEARCH AND DEVELOPMENT

Subject Classification: 7512 .Astronautics--General (1975-)

1047985 N80-11112

Evaluation criteria for commercially oriented materials processing in space proposals

Final Report

MOORE, W. F.; MCDOWELL, J. R.

Battelle Columbus Labs., Ohio.

Corp. Source Code: BD967734

Publication Date: Jan. 1979 58P.

Report No.: NASA-CR-162437; BCL-OA-TFR-78-5

Contract No.: NASW-2800

Language: English

Country of Origin: United States Country of Publication:  
United States

Document Type: REPORT

(cont. next page)

ORIGINAL PAGE IS  
OF POOR QUALITY

## DIALOG File 108: AEROSPACE - 82-86/ISS09

Most documents available from AIAA Technical Library  
Other Availability: NFIS HC A04/MF A01  
Journal Announcement: STAR8002

An approach and criteria for evaluating NASA funded experiments and demonstrations which have commercial potential were developed. Methods for insuring quick initial screening of commercial proposals are presented. Recommendations are given for modifying the current evaluation approach. New criteria for evaluating commercially orientated materials processing in space (MPS) proposals are introduced. The process for selection of qualified individuals to evaluate the phases of this approach and criteria is considered and guidelines are set for its implementation. (R.C.T.)

Source of Abstract/Subfile: NASA STIF

Descriptors: +MANAGEMENT PLANNING; +SPACE MANUFACTURING;  
+SPACEBORNE EXPERIMENTS; COMMERCE; INDUSTRIES; MARKET RESEARCH  
; TECHNOLOGY UTILIZATION

Subject Classification: 7512 .Astronautics--General (1975-)  
COSATI Code: 22A .Astronautics

1040601 A80-47800

## Mining the moon

HURLICH, A.

American Society for Metals, Heat Treating  
Conference-Workshop, 5th, Detroit, Mich., May 6-8, 1980,  
Paper, 39 p.

Publication Date: May 1980 20 Refs.

Language: English

Country of Publication: United States

Document Type: CONFERENCE PAPER

Most documents available from AIAA Technical Library

Journal Announcement: IAA8021

The selection, extraction and processing of materials required for various construction projects in space are discussed and the significance for solar power station satellites and space settlements is investigated. The compositions of the moon and the earth are compared and diagrammed with differences highlighted and variations in the recovery process presented. Earth and lunar production costs are compared, especially with regards to the processing of silicon for solar panels. Emphasis is placed on utilizing features of the lunar and space environments in the development of a materials industry. (R.C.)

Source of Abstract/Subfile: AIAA/TIS

Descriptors: +EXTRATERRESTRIAL RESOURCES; +LUNAR SOIL;  
+MINING; +MOON; +SPACE INDUSTRIALIZATION; GLASS; METALS;  
SILICON; SOLAR POWER SATELLITES; SPACE MANUFACTURING; SPACE  
PROCESSING

Subject Classification: 7512 .Astronautics--General (1975-)

1040471 A80-47670

MINOS - A space system for the industrial production of  
materials in orbit

MINOS - Systeme spatial pour la production industrielle de  
materiaux en orbite

SERRADEIL, R. (Centre National d'Etudes Spatiales, Paris, France); TOROSSIAN, R. (Societe Nationale Industrielle Aeronautique, Les Mureaux, Yvelines, France); DOMAULAM, M. (MATRA, S.A., Velizy-Villacoublay, Yvelines, France)

L'Aeronautique et Astronautique, no. 82, 1980, p. 3-10. In French.

Publication Date: 1980

Language: French

Country of Origin: France Country of Publication: France

Document Type: JOURNAL ARTICLE

Most documents available from AIAA Technical Library

Journal Announcement: IAA8021

The MINOS (French acronym for Modules for Space Industry and Observation) system approach to an automatic orbital station for the industrial production of materials in space is presented. Consideration is given to the possible materials to be processed by the station and associated system requirements, and the results of baseline studies concerning the functions and subsystems determining the orbit and configuration of the system are outlined. The components of the proposed system are then described, with attention given to the service module, which fulfills the functions of stabilization, energy and communications, and the shuttle vehicle, to be launched by Ariane and be responsible for returning products to earth. The design of a multimission MINOS system is then considered, with attention given to the modular design, shuttle vehicle, standard modules and the arrangement of the modules, and areas requiring further technical development are indicated. (A.L.W.)

Source of Abstract/Subfile: AIAA/TIS

Descriptors: +FRENCH SPACE PROGRAMS; +ORBITAL SPACE STATIONS  
; +SPACE MANUFACTURING; DESIGN ANALYSIS; MODULES; SPACE  
MISSIONS; SPACE SHUTTLES; SPACE TRANSPORTATION; TECHNOLOGY  
UTILIZATION

Subject Classification: 7512 .Astronautics--General (1975-)

1024592 A80-31791

## The industrialisation of space

PARDOE, G. K. C. (General Technology Systems, Ltd., London, England)

British Interplanetary Society, Journal (Space and Education), vol. 33, May 1980, p. 195-200.

Publication Date: May 1980

Language: English

Country of Origin: United Kingdom Country of Publication:  
United Kingdom

Document Type: JOURNAL ARTICLE

Most documents available from AIAA Technical Library

Journal Announcement: IAA8012

It is noted that the industrialization of space has rested and will continue to rest to a major extent on the support and stimulus of defense programs. The present paper examines the more publicly visible activities in space. Discussion covers the progressive use of space to date, noting the introduction

(cont. next page)

ORIGINAL PAGE IS  
OF POOR QUALITY

## DIALOG File 108: AEROSPACE - 82-88/ISS09

of commercially based communications satellites in the 1960s. Also examined is the growth of industrialization and the commercial implications of earth observation satellites, in-orbit material processing, orbital antenna farm, and space power system. Finally, it is concluded that the current reluctance of sectors of industry to innovate must be reversed since the solving of future problems will require a more revolutionary approach. (M.E.P.)

Source of Abstract/Subfile: AIAA/TIS

Descriptors: \*SPACE INDUSTRIALIZATION; \*TECHNOLOGY UTILIZATION; ANTENNAS; COMMUNICATION SATELLITES; DEFENSE PROGRAM; EARTH OBSERVATIONS (FROM SPACE); ELECTRIC GENERATORS ENERGY TECHNOLOGY; MILITARY TECHNOLOGY; SOLAR POWER SATELLITES; SPACE PROCESSING

Subject Classification: 7512 .Astronautics--General (1975-)

1007572 A80-14771

Space - Everyone benefits, Proceedings of the Sixteenth Space Congress, Cocoa Beach, Fla., April 25-27, 1979; et al.

Congress sponsored by the Canaveral Council of Technical Societies, Cocoa Beach, Fla., Canaveral Council of Technical Societies, 1979. 325 p (For individual items see A80-14772 to A80-14793)

Publication Date: 1979

Language: English

Country of Publication: United States

Document Type: CONFERENCE PROCEEDINGS

Journal Announcement: IAA8003

Papers are presented on such areas as Shuttle update, DOD initiatives in space, Spacelab, payload planning, space commercialization, and technology transfer. Particular consideration is given to the Shuttle orbital flight test, leased military space communication systems, Spacelab flight operations, commercialization of materials processing in space, and medical applications of aerospace technology. (B.J.)

Source of Abstract/Subfile: AIAA/TIS

Descriptors: \*AEROSPACE TECHNOLOGY TRANSFER; \*CONFERENCES; \*SPACE MISSIONS; \*SPACE TRANSPORTATION SYSTEM; \*TECHNOLOGY UTILIZATION; DEFENSE PROGRAM; EXTERNAL TANKS; FLIGHT OPERATIONS; GROUND SUPPORT SYSTEMS; LANDSAT SATELLITES; MEDICAL SCIENCE; OPTICAL COMMUNICATION; SOCIOLOGY; SOLAR POWER SATELLITES; SPACE INDUSTRIALIZATION; SPACE SHUTTLE ORBITERS; SPACE SHUTTLE PAYLOADS; SPACE SURVEILLANCE (SPACEBORNE); SPACE TRANSPORTATION SYSTEM FLIGHTS; SPACELAB PAYLOADS; TECHNOLOGY ASSESSMENT

Subject Classification: 7512 .Astronautics--General (1975-)

0984844 N79-16022

Study of iron-borate materials systems processed in space

Final Report, 27 Sep. 1977 - 26 Sep. 1978

NEILSON, G. F.

Owens-Illinois, Inc., Toledo, Ohio.

Corp. Source Code: 08815627

Publication Date: Aug. 1978 42P.

Report No.: NASA-CR-150888

Contract No.: NAS8-32659

Language: English

Country of Origin: United States Country of Publication: United States

Document Type: REPORT

Most documents available from AIAA Technical Library

Other Availability: NTIS HC A03/MF A01

Journal Announcement: STAR7907

It was calculated that an FeB03B203 glass-ceramic containing only 1 mole% FeB03 would be equivalent for magneto optic application to a YIG crystal of equal thickness. An Fe203B203 composition containing 2 mole% FeB03 equivalent (98B) could be converted largely to a dense green, though opaque, FeB03 glass-ceramic through suitable heat treatments. However, phase separation (and segregation) and Fe+3 reduction could not be entirely avoided with the various procedures that were employed. From light scattering calculations, it was estimated that about 100 A to allow 90% light transmission through a 1 cm thick sample. However, the actual FeB03 crystallite sizes obtained in 98B were of the order of 1 micron or greater. (Author)

Descriptors: \*BORATES; \*IRON COMPOUNDS; \*SPACE MANUFACTURING; CERAMICS; GLASS; HEAT TREATMENT; LIGHT SCATTERING

Subject Classification: 7512 .Astronautics--General (1975-)

COSATI Code: 22A .Astronautics

0982963 N79-14120

Nonterrestrial material processing and manufacturing of large space systems

VONTIESENHAUSEN, G. F.

National Aeronautics and Space Administration, Marshall Space Flight Center, Huntsville, Ala.

Corp. Source Code: ND736801

Publication Date: Nov. 1978 31P.

Report No.: NASA-TM-78207

Language: English

Country of Origin: United States Country of Publication: United States

Document Type: REPORT

Most documents available from AIAA Technical Library

Other Availability: NTIS HC A03/MF A01

Journal Announcement: STAR7905

An attempt is made to provide pertinent and readily usable information on the extraterrestrial processing of materials and manufacturing of components and elements of these planned large space systems from preprocessed lunar materials which are made available at a processing and manufacturing site in space. Required facilities, equipment, machinery, energy and manpower are defined. (Author)

Descriptors: \*AEROSPACE ENGINEERING; \*SPACE MANUFACTURING; \*SPACE STATIONS; CONSTRUCTION; FABRICATION; MOON; PRODUCTION ENGINEERING

(cont. next page)

DIALOG File 108: AEROSPACE - 62-86/ISS09

Subject Classification: 7512 .Astronautics--General (1975-)  
COSATI Code: 22A .Astronautics

0977685 A79-53303

**Chemical processing of lunar materials**

CRISWELL, D. R.; WALDRON, R. D. (Lunar and Planetary Institute, Houston, Tex.)

Lunar and Planetary Inst., Houston, Tex.

Corp. Source Code: L8618929

International Astronautical Federation, International Astronautical Congress, 30th, Munich, West Germany, Sept. 17-22, 1979, 20 p.

Publication Date: Sep. 1979 7 Refs.

Report No.: IAF PAPER 79-116

Contract No.: NSR-09-051-001

Language: English

Country of Origin: United States Country of Publication: International Organization

Document Type: CONFERENCE PAPER

Most documents available from AIAA Technical Library

Journal Announcement: IAA7924

The paper highlights recent work on the general problem of processing lunar materials. The discussion covers lunar source materials, refined products, motivations for using lunar materials, and general considerations for a lunar or space processing plant. Attention is given to chemical processing through various techniques, including electrolysis of molten silicates, carbothermic/silicothermic reduction, carbo-chlorination process, NaOH basic-leach process, and HF acid-leach process. Several options for chemical processing of lunar materials are well within the state of the art of applied chemistry and chemical engineering to begin development based on the extensive knowledge of lunar materials. (S.D.)

Source of Abstract/Subfile: AIAA/TIS

Descriptors: \*CHEMICAL ENGINEERING; \*LUNAR ROCKS; \*LUNAR SOIL; \*SPACE MANUFACTURING; BENEFICIATION; CHLORINATION; ELECTROLYSIS; HYDROFLUORIC ACID; LEACHING; MATERIALS HANDLING SPACE INDUSTRIALIZATION

Subject Classification: 7512 .Astronautics--General (1975-)

0977664 A79-53282

**The Minos system (automatic station for space manufacturing)**

CACHEUX, J. (Centre National d'Etudes Spatiales, Toulouse, France); TOROSSIAN, R. (Societe Nationale Industrielle Aerospatiale, Les Mureaux Yvelines, France); DO-MAU-LAM, M. (Matra, S.A., Division Etudes et Syntheses, Velizy-Villacoublay, Yvelines, France)

International Astronautical Federation, International Astronautical Congress, 30th, Munich, West Germany, Sept. 17-22, 1979, 27 p.

Publication Date: Sep. 1979

Report No.: IAF PAPER 79-68

Language: English

Country of Origin: France Country of Publication: International Organization

Document Type: CONFERENCE PAPER

Most documents available from AIAA Technical Library

Journal Announcement: IAA7924

The present paper deals with the orbiting Minos station intended for processing materials in space, whose design and specifications are being developed to match the capabilities of the Ariane booster. The structure of the spacecraft is described, along with the solar panels, energy storage, control systems, tracking, communications, telemetry, and on-board computer system. (V.P.)

Source of Abstract/Subfile: AIAA/TIS

Descriptors: \*FRENCH SPACE PROGRAMS; \*ORBITAL SPACE STATIONS; \*SPACE MANUFACTURING; \*SPACE PROCESSING; ARIANE LAUNCH VEHICLE; FREE FLIGHT; GUYANA; REENTRY VEHICLES; RENDEZVOUS SPACECRAFT; SERVICE MODULES; SPACECRAFT POWER SUPPLIES; SPACECRAFT STRUCTURES

Subject Classification: 7512 .Astronautics--General (1975-)

0976067 A79-51685

**Alloys out of weightlessness (space manufacturing of semiconductors)**

Splavy iz nevesomosti

SAVITSKII, E.; IVANOV, L.; ZEMSKOV, V.

Aviatsiya i Kosmonavtika, July 1979, p. 42, 43. In Russian.

Publication Date: Jul. 1979

Language: Russian

Country of Publication: U.S.S.R.

Document Type: JOURNAL ARTICLE

Most documents available from AIAA Technical Library

Journal Announcement: IAA7923

Some results of technological experiments on board the Salut-6/Soyuz space laboratory are reviewed. X-ray photographs of an aluminum-tungsten alloy and an aluminum-bismuth alloy and their terrestrial counterparts are given and discussed. Study of the microstructure shows suppression of liquation and a more uniform phase distribution than in terrestrial specimens. Also, the primary crystals are larger with a more perfect faceting. Under terrestrial conditions, the components of the aluminum-bismuth alloy are distributed in two separate rows, whereas under space conditions they are mixed. (V.P.)

Source of Abstract/Subfile: AIAA/TIS

Descriptors: \*CADMIUM TELLURIDES; \*MERCURY TELLURIDES; \*SEMICONDUCTORS (MATERIALS); \*SPACE MANUFACTURING; \*WEIGHTLESSNESS; ALLOYS; CRYSTALLIZATION; GLASS; MICROSTRUCTURE; X RAY SPECTROSCOPY

Subject Classification: 7526 .Metallic Materials (1975-)

0967850 A79-43467

**Post-Apollo revisited**

MUELLER, G. E. (System Development Corp., Santa Monica, Calif.)

Astronautics and Aeronautics, vol. 17, July-Aug. 1979, p. 24-31.

(cont. next page)



## DIALOG File 108: AEROSPACE - 82-86/ISS09

Publication Date: Aug. 1979  
 Language: English  
 Country of Origin: United States Country of Publication: United States  
 Document Type: JOURNAL ARTICLE  
 Most documents available from AIAA Technical Library  
 Journal Announcement: IAA7918

The reasons for the slowdown in the U.S. space program experienced in the 1970's are considered, and the effects of the relatively limited advances made in this period are assessed. High-priority objectives for the future which are politically palatable and which could be accomplished within the budget limitations presently imposed on the space program are identified and described. These include the use of space for defense, the development of large multipurpose information platforms, materials processing factories in space, nuclear waste disposal in space, exploitation of resources on the moon and asteroids, additional manned expeditions to the moon, space colonization, space-based solar power generation, orbital transportation service between continents, and search for extraterrestrial intelligence. The technological advances necessary for these programs are examined. The importance of developing advanced propulsion and low-cost reusable systems is stressed. (C.K.D.)

Source of Abstract/Subfile: AIAA/TIS  
 Descriptors: +NASA PROGRAMS; +SPACE INDUSTRIALIZATION; +SPACE PROGRAMS; +TECHNOLOGICAL FORECASTING; DEFENSE PROGRAM; EXTRATERRESTRIAL INTELLIGENCE; LARGE SPACE STRUCTURES; LOW COST; MANNED SPACE FLIGHT; NUCLEAR FUELS; REUSABLE LAUNCH VEHICLES; SPACE COLONIES; SPACEBORNE EXPERIMENTS; WASTE DISPOSAL

Subject Classification: 7512 .Astronautics--General (1975-)

0967630 A79-43247

Nonterrestrial material processing and manufacturing of large space systems

VON TIESENHAUSEN, G. (NASA, Marshall Space Flight Center, Advanced Systems Office, Huntsville, Ala.)

National Aeronautics and Space Administration, Marshall Space Flight Center, Huntsville, Ala.

Corp. Source Code: ND736801

In: The enigma of the eighties: Environment, economics, energy: Proceedings of the Twenty-fourth National Symposium and Exhibition, San Francisco, Calif., May 8-10, 1979. Book 1. (A79-43228 18-23) Azusa, Calif., Society for the Advancement of Material and Process Engineering, 1979. p. 270-284.

Publication Date: 1979 8 Refs.

Language: English

Country of Origin: United States Country of Publication: United States

Document Type: CONFERENCE PAPER

Journal Announcement: IAA7918

Nonterrestrial processing of materials and manufacturing of large space system components from preprocessed lunar materials at a manufacturing site in space is described. Lunar materials mined and preprocessed at the lunar resource complex

will be flown to the space manufacturing facility (SMF), where together with supplementary terrestrial materials, they will be final processed and fabricated into space communication systems, solar cell blankets, radio frequency generators, and electrical equipment. Satellite Power System (SPS) material requirements and lunar material availability and utilization are detailed, and the SMF processing, refining, fabricating facilities, material flow and manpower requirements are described. (A.T.)

Source of Abstract/Subfile: AIAA/TIS

Descriptors: +EXTRATERRESTRIAL RESOURCES; +LARGE SPACE STRUCTURES; +LUNAR ROCKS; +SPACE MANUFACTURING; +SPACE PROCESSING; ABUNDANCE; AVAILABILITY; ORBITAL ASSEMBLY; SPACE INDUSTRIALIZATION

Subject Classification: 7512 .Astronautics--General (1975-)

0958131 A79-33748

Commercial prospects for extraterrestrial materials

CRISWELL, D. R.; WALDRON, R. D. (Lunar and Planetary Institute, Houston, Tex.)

Lunar and Planetary Inst., Houston, Tex.

Corp. Source Code: LB618929

Journal of Contemporary Business, vol. 7, no. 3, 1978, p. 153-169.

Publication Date: 1978 18 Refs.

Contract No.: NSR-09-051-001

Language: English

Country of Origin: United States Country of Publication: United States

Document Type: JOURNAL ARTICLE

Most documents available from AIAA Technical Library

Journal Announcement: IAA7913

Prospects for using lunar resources as materials for spaceborne construction are examined. The use of lunar construction materials is considered economically justifiable in the case of such large scale projects as space power stations (SPS). A proposed scenario for the acquisition and space processing of lunar materials involves the use of space shuttles to deliver an assembly base to earth orbit, where a solar powered mass driver reaction engine rocket is assembled and used to bring sections of a lunar base from low earth orbit to the moon. The rocket would then be positioned at the L2 equilibrium point in order to catch lunar soil propelled into space by a mass driver and bring it to the assembly base for chemical processing. Cost factors would be comparable to those of the terrestrial deployment of the first SPS, and such a project could be in operation before the end of the century. (A.L.W.)

Source of Abstract/Subfile: AIAA/TIS

Descriptors: +EXTRATERRESTRIAL RESOURCES; +LUNAR BASES; +MARKET RESEARCH; +SATELLITE SOLAR POWER STATIONS; +SPACE INDUSTRIALIZATION; COST ANALYSIS; MINES (EXCAVATIONS); SPACE SHUTTLES

Subject Classification: 7512 .Astronautics--General (1975-)

## DIALOG File 108: AEROSPACE - 62-86/ISS09

0948832 A79-24449

**Industry's new frontier in space**

BYLINSKY, G.

Fortune, vol. 99, Jan. 29, 1979, p. 76-79, 82, 84.

Publication Date: Jan. 1979

Language: English

Country of Publication: United States

Document Type: JOURNAL ARTICLE

Most documents available from AIAA Technical Library

Journal Announcement: IAA7908

The advantages of manufacturing in space are discussed, together with a detailed description of the materials to be processed aboard the Spacelab of NASA's Shuttle. Gravity includes convection currents which lead to unpredictable and undesirable structural and composition difference in solids, tending to separate the different materials contained in a liquid, with the resulting solid lacking uniformity. Most such problems disappear in the weightlessness of outer space making thus possible the production of higher quality materials, as for example metals displaying self-lubricating properties of superconducting qualities. Further, studies show that there are more than 400 alloys that cannot be made on earth because of the gravitational pull. In the microgravity of an orbiting spacelab NASA will be able to produce crystals, alloys, and medicines (e.g. pure interferon, endorphins, and erythropoietin) never seen on earth. (A.A.)

Source of Abstract/Subfile: AIAA/TIS

Descriptors: \*NASA PROGRAMS; \*SPACE INDUSTRIALIZATION; \*SPACE MANUFACTURING; \*SPACE PROCESSING; \*SPACE SHUTTLES; CONTAINERLESS MELTS; ECONOMIC FACTORS; MATERIALS SCIENCE; TECHNOLOGICAL FORECASTING; WEIGHTLESSNESS

Subject Classification: 7512 .Astronautics--General (1975-)

0945073 A79-20690

**Industry in space ( Russian book on space processing and manufacturing)**

Industria v kosmose

EVICH, A. F.

Moscow, Izdatel'stvo Moskovskii Rabochii, 1978. 224 p. In Russian.

Publication Date: 1978 30 Refs.

Language: Russian

Country of Publication: U.S.S.R.

Document Type: BOOK

Most documents available from AIAA Technical Library

Journal Announcement: IAA7907

The book discusses the prospects for carrying out various types of industrial processes in space. The physical conditions prevailing in space are reviewed, phenomena such as convection, diffusion, and surface tension under zero-gravity conditions are discussed, experimental methods of simulating weightlessness, are briefly described, and results of first technological experiments in space on Soyuz 6, Skylab, and the Salyut series of spacecraft are summarized. Possibilities for producing hollow spheres in space or for producing foam metal are discussed. Schemes for crystal growing, electrophoresis,

using the sun as heat source, and other technologies for space are studied. (P.T.H.)

Source of Abstract/Subfile: AIAA/TIS

Descriptors: \*AEROSPACE ENGINEERING; \*LOW GRAVITY MANUFACTURING; \*SPACE INDUSTRIALIZATION; \*SPACE MANUFACTURING \*SPACE PROCESSING; AEROSPACE ENVIRONMENTS; CRYSTAL GROWTH; ELECTROPHORESIS; INTERFACIAL TENSION; REDUCED GRAVITY; SALYUT SPACE STATION; SOVIET SPACECRAFT; SOYUZ SPACECRAFT; U.S.S.R. SPACE PROGRAM

Subject Classification: 7512 .Astronautics--General (1975-)

## DIALOG FILE 108: AEROSPACE - 62-86/ISS09

0943872 A79-19489

**Processing of glass in space**

DOREMIUS, R. H. (California, University, Berkeley, Calif.;  
Rensselaer Polytechnic Institute, Troy, N.Y.)  
American Institute of Aeronautics and Astronautics,  
Aerospace Sciences Meeting, 17th, New Orleans, La., Jan.  
15-17, 1979. 7 p.

Publication Date: Jan. 1979

Report No.: AIAA PAPER 79-0031

Language: English

Country of Origin: United States Country of Publication:  
United States

Document Type: CONFERENCE PAPER

Most documents available from AIAA Technical Library

Journal Announcement: IAA7906

New glass compositions should result from space processing. To make a glass, a liquid must be cooled rapidly enough to prevent nucleation of crystals, and the elimination of container walls, a common source of nucleation, should lead to new glass-forming compositions. Fundamentals of nucleation and growth of crystals in glass are discussed. Rapid heat transfer is also important in glass forming; the special conditions of heat transfer in space processing must be carefully controlled for successful melting of easily crystallized glasses. Fining and homogenization are important problems in making glasses, but they present no special problems for glass melting in space. ((Author))

Descriptors: \*GLASS; \*SPACE PROCESSING; BUBBLES;  
CRYSTALLIZATION; HOMOGENEITY; MELTING; NUCLEATION; REACTION  
KINETICS; SPACE MANUFACTURING; SUPERCOOLING; WEIGHTLESSNESS

Subject Classification: 7512 .Astronautics--General (1975-)

0918647 N78-18088

**AIAA/MSFC Symposium on Space Industrialization: Proceedings**

National Aeronautics and Space Administration, Marshall  
Space Flight Center, Huntsville, Ala.

Corp. Source Code: ND736801

Publication Date: 1976 627P.

Presentation Note: Proc. held at Huntsville, Ala., 26-27 May  
1976

Report No.: NASA-CP-2026

Language: English

Country of Origin: United States Country of Publication:  
United States

Document Type: COLLOQUIA

Most documents available from AIAA Technical Library

Other Availability: NTIS HC A99/MF A01

Journal Announcement: STAR7809

Current and projected technologies required for utilizing extraterrestrial environments to produce energy, information, or materials and provide services of value on Earth or to Earth are discussed. Topics include: space habitats, space transportation, materials processing, solar space power, and exoindustrial management concepts. (A.R.H.)

Source of Abstract/Subfile: NASA STIF

Descriptors: \*CONFERENCES; \*SATELLITE SOLAR POWER STATIONS;

\*SPACE MANUFACTURING; \*SPACE PROCESSING; \*SPACE STATIONS;  
\*SPACE TRANSPORTATION; COST ESTIMATES; ENERGY TECHNOLOGY;  
LIQUID ROCKET PROPELLANTS; METALLURGY; MICROWAVE TRANSMISSION  
ORBITAL ASSEMBLY

Subject Classification: 7512 .Astronautics--General (1975-)  
COSATI Code: 22A .Astronautics

0903211 A78-46496

**Material sciences in space. II - Future interest and expectations (from Spacelab experiments)**

SEIBERT, G. (ESA, Directorate of Planning and Future  
Programmes, Paris, France)

ESA Journal, vol. 2, no. 2, 1978, p. 99-109.

Publication Date: 1978 13 Refs.

Language: English

Country of Origin: International Organization Country of  
Publication: Netherlands

Document Type: JOURNAL ARTICLE

Most documents available from AIAA Technical Library

Journal Announcement: IAA7820

Various material-science experiments which may be performed under near-weightlessness in space are outlined. Two methods of electrophoretic separation are described: free-flow electrophoresis, and static-zone electrophoresis. Attention is given to the preparation of isotropic composite materials, the production of two-phase alloys by solidification with a miscibility gap in the liquid state, the production of foamed metals, the preparation of defect-free single crystals and aligned eutectics, and levitation melting. Space-grown crystals are outlined with reference to their use as elementary semiconductors and compound semiconductors. Studies in fluid physics and fluid dynamics in near-zero-gravity conditions are evaluated. (S.C.S.)

Source of Abstract/Subfile: AIAA/TIS

Descriptors: \*MATERIALS SCIENCE; \*SPACE MANUFACTURING;  
\*SPACE PROCESSING; \*SPACELAB; AEROSPACE ENVIRONMENTS; ALLOYS;  
BIOCHEMISTRY; CERAMICS; COMPOSITE MATERIALS; CRYSTALLOGRAPHY;  
ELECTROPHORESIS; FLUID DYNAMICS; METALLURGY; MICROSTRUCTURE;  
PARTICLE MOTION; SEMICONDUCTORS (MATERIALS); SPACE SHUTTLES;  
WEIGHTLESSNESS

Subject Classification: 7512 .Astronautics--General (1975-)

0900597 A78-43881

**A baseline of logistic and power requirements for full-scale manufacturing of metallic materials in earth orbit**

BLOOM, H. (General Electric Co., Space Div., Valley Forge,  
Pa.)

In: The industrialization of space; Proceedings of the  
Twenty-third Annual Meeting, San Francisco, Calif., October  
18-20, 1977. (A78-43876 19-12) San Diego, Calif., American  
Astronautical Society; Univelt, Inc., 1978. 22 p.

Publication Date: 1978 11 Refs.

Report No.: AAS 77-237

(cont. next page)

## DIALOG File 108: AEROSPACE - 62-86/ISS09

Language: English  
Country of Origin: United States Country of Publication: United States

Document Type: CONFERENCE PAPER

Journal Announcement: IAA7819

A number of preliminary surveys have been carried out to identify potential space-processed materials that might be of sufficient worth in earth-based applications to warrant their full-scale production in space. From these surveys, this paper extracts those quantities of materials to be transported and stored, physical parameters of production equipment and facilities, on-orbit operating needs, crew needs, and power requirements that are upper limits of space processing requirements. These data are then developed into a representative baseline of the logistics and power requirements of a future mature space manufacturing program. (B.J.)

Source of Abstract/Subfile: AIAA/TIS

Descriptors: \*ENERGY REQUIREMENTS; \*ENERGY SOURCES; \*LOGISTICS MANAGEMENT; \*MATERIALS HANDLING; \*METALS; \*SPACE MANUFACTURING; EARTH ORBITS; ENERGY TECHNOLOGY; PRODUCTION ENGINEERING; RESEARCH FACILITIES; SATELLITE ORBITS; SPACE INDUSTRIALIZATION; SPACE PROCESSING; SPACECRAFT POWER SUPPLIES; TECHNOLOGICAL FORECASTING; TECHNOLOGY UTILIZATION

Subject Classification: 7512 .Astronautics--General (1975-)

0893819 A78-37102

Material sciences in space. I - Review of space experiments to date

SEIBERT, G. (ESA, Paris, France)

ESA Journal, vol. 2, no. 1, 1978, p. 7-17.

Publication Date: 1978 5 Refs.

Language: English

Country of Origin: International Organization Country of Publication: Netherlands

Document Type: JOURNAL ARTICLE

Most documents available from AIAA Technical Library

Journal Announcement: IAA7815

Composite solidification, electrophoresis, fluid flow, metal processing and single-crystal growth experiments have been conducted on Apollo and Skylab missions and in the course of the Apollo-Soyuz Test Project (ASTP). Containerless growth of an indium antimonide single crystal on board Skylab is discussed; the Skylab multipurpose electric furnace, which uses less than 200 watts to attain a maximum temperature of 1000 C, is also described. The topics studied during the ASTP included surface-tension-induced convection, halide eutectic growth, the monotectic alloy Pb-Zn, the syntectic alloy AlSiB, germanium crystal growth, crystal growth processes relying on vapor-phase deposition, and the application of electrophoresis to biological experiments in space. (J.M.B.)

Source of Abstract/Subfile: AIAA/TIS

Descriptors: \*SPACE PROCESSING; \*SPACEBORNE EXPERIMENTS; APOLLO FLIGHTS; APOLLO SOYUZ TEST PROJECT; CRYSTAL GROWTH; ELECTROPHORESIS; EUTECTICS; METALLURGY; SINGLE CRYSTALS; SKYLAB PROGRAM; SOLIDIFICATION; SPACE MANUFACTURING

Subject Classification: 7512 .Astronautics--General (1975-)  
0893433 A78-36716

A road map to space products (extraterrestrial manufactured products for Earth use)

HAMMEL, R. L.; WALTZ, D. M. (TRW Defense and Space Systems Group, Redondo Beach, Calif.)

In: The industrialization of space: Proceedings of the Twenty-third Annual Meeting, San Francisco, Calif., October 18-20, 1977. Part 1. (A78-36701 15-12) San Diego, Calif., American Astronautical Society; Univelt, Inc., 1978, p. 363-390.

Publication Date: 1978 6 Refs.

Report No.: AAS 77-239

Language: English

Country of Origin: United States Country of Publication: United States

Document Type: CONFERENCE PAPER

Journal Announcement: IAA7815

The advantages of a processing of materials in space are related to the presence of the low-gravity environment, the vacuum conditions, and the readily available solar energy. Five basic types of processes envisioned are related to crystal growth, purification/separation, mixing, solidifications, and processes in fluids. Potential space products are listed in a table. Electronic products considered include semiconductors, integrated circuit chips, magnetic switches, relays, magnetic detectors, ultrasonic and optical frequency filters, superconductors, and X-ray targets. Optical and biological products envisaged are related to large diameter crystals, uniformly doped crystals, high index of refraction glasses, IR-transmitting glasses, improved fiber optics, holographic storage devices, high-purity biologicals for use in making vaccines, human cell purification, enzyme isolation, and protein purification and production. Materials for structural uses comprise better turbine blade materials, high strength composites, and high purity materials. A description is presented of the development of space manufacturing during the flight research phase (1965-1984), the product and process development phase (1982-1990), and the industrial utilization phase (1990-2000). (G.R.)

Source of Abstract/Subfile: AIAA/TIS

Descriptors: \*EXTRATERRESTRIAL RESOURCES; \*LOW GRAVITY MANUFACTURING; \*PRODUCT DEVELOPMENT; \*SOLAR ENERGY; \*SPACE MANUFACTURING; \*VACUUM EFFECTS; CRYSTAL GROWTH; DOPED CRYSTALS; DRUGS; ELECTRONIC EQUIPMENT; GOVERNMENT/INDUSTRY RELATIONS; LEGAL LIABILITY; SPACE PROCESSING; SPACE STATIONS; TECHNOLOGY UTILIZATION; WEIGHTLESSNESS

Subject Classification: 7512 .Astronautics--General (1975-)

0877413 A78-20696

Planning for materials processing in space

BARKSDALE, W. J. (South Carolina, University, Columbia, S.C.); GROGGER, P. K. (Colorado, University, Colorado Springs, Colo.); LUEG, R. E. (Alabama, University, University, Ala.);

(cont. next page)

## DIALOG File 108: AEROSPACE - 62-86/ISS09

PEARSON, J. V. (John Brown University, Siloam Springs, Ark.);  
VANCE, R. G. (Eastern Kentucky University, Richmond, Ky.)

American Institute of Aeronautics and Astronautics,  
Aerospace Sciences Meeting, 16th, Huntsville, Ala., Jan.  
16-18, 1978, 11 p.

Publication Date: Jan. 1978

Report No.: AIAA PAPER 78-126

Language: English

Country of Origin: United States Country of Publication:  
United States

Document Type: CONFERENCE PAPER

Most documents available from AIAA Technical Library

Journal Announcement: IAA7807

A systems design study to describe the conceptual evolution, the institutional interrelationships and the basic physical requirements to implement materials processing in space was conducted. Planning for a 'processing era' is emphasized in this report rather than the design of hardware. A concept for modular, unmanned orbiting facilities using the modified external tank of the Shuttle is presented. Organizational and funding structures which would provide for the efficient movement of materials from user to space and provide the incentive for industry participation are outlined. The use of advisory committees in two areas, planning for the preparation of a social impact assessment and an environmental impact statement, and identifying this program with a national goal are recommended to NASA as means of increasing public support for materials processing in space. The Design Team of 19 participants concluded there would be a 'processing era' before 2000. Eighteen specific recommendations are made to NASA to help implement that era. ((Author))

Descriptors: \*PROJECT PLANNING; \*SPACE MANUFACTURING; \*SPACE PROCESSING; APOLLO SOYUZ TEST PROJECT; FEASIBILITY ANALYSIS; GOVERNMENT/INDUSTRY RELATIONS; RESEARCH AND DEVELOPMENT; SKYLAB PROGRAM; SPACE SHUTTLES; USER REQUIREMENTS

Subject Classification: 7512 .Astronautics--General (1975-)

0876261 A78-19544

New works in space (Space Shuttle based manufacturing and services)

KINGSBURY, J. E. (NASA, Marshall Space Flight Center, Huntsville, Ala.)

National Aeronautics and Space Administration, Marshall Space Flight Center, Huntsville, Ala.

Corp. Source Code: ND736801

Astronautics and Aeronautics, vol. 16, Jan. 1978, p. 32-38.

Publication Date: Jan. 1978

Language: English

Country of Origin: United States Country of Publication:  
United States

Document Type: JOURNAL ARTICLE

Most documents available from AIAA Technical Library

Journal Announcement: IAA7806

Goods and services that may be furnished by the Space Shuttle are described. A single multibeam antenna array capable of supplying satellite communication for 256 U.S.

cities, a disaster warning network, and a TV link to remote areas is discussed. Attention is also given to such materials processing programs as crystal growth (for example, production of mercuric iodide crystals for gamma-ray detectors), eutectic growth of solid-solution crystals such as mercury-cadmium-telluride, manufacture of uniform latex spheres for medical applications, and development of small glass spheres for fusion power applications. In addition to the Space Telescope, a meter-class telescope on the Shuttle and a wide-field survey instrument are under study. (J.M.B.)

Source of Abstract/Subfile: AIAA/TIS

Descriptors: \*COMMUNICATION SATELLITES; \*SATELLITE NETWORKS \*SPACE MANUFACTURING; \*SPACE SHUTTLES; \*TECHNOLOGY ASSESSMENT CRYSTAL GROWTH; SPACEBORNE ASTRONOMY; SPACEBORNE TELESCOPES; TECHNOLOGICAL FORECASTING; WEIGHTLESSNESS

Subject Classification: 7512 .Astronautics--General (1975-)

0873901 A78-17184

The concept of space-based manufacturing facilities

ONEILL, G. K. (Princeton University, Princeton, N.J.)

In: Space-based manufacturing from nonterrestrial materials. (A78-17183 05-12) New York, American Institute of Aeronautics and Astronautics, Inc., 1977, p. 3-18.

Publication Date: 1977 13 Refs.

Language: English

Country of Origin: United States Country of Publication:  
United States

Document Type: ANALYTIC OF COLLECTED WORK

Journal Announcement: IAA7805

A theoretical discussion concerning the development of space-based manufacturing facilities is presented. The space-habitat concept, i.e., an in-space self-supporting technological civilization built on rotating pressure vessels is discussed. The development of a solar-powered lunar-materials transporter is proposed, noting various possible configurations. Factors involved in material processing in space are reviewed along with procedures for the maintenance of an in-space workforce. Attention is also given to human tolerance to rotation as it concerns space-habitat development cost, and to the construction of maximum-strength, minimum-mass structures for such applications. (S.C.S.)

Source of Abstract/Subfile: AIAA/TIS

Descriptors: \*MATERIALS HANDLING; \*SPACE MANUFACTURING; \*SPACE STATIONS; CISLUNAR SPACE; CLOSED ECOLOGICAL SYSTEMS; EXTRATERRESTRIAL RESOURCES; HUMAN TOLERANCES; LAGRANGIAN EQUILIBRIUM POINTS; LIBRATION; LUNAR ROCKS; PAYLOADS

Subject Classification: 7512 .Astronautics--General (1975-)

0872647 A78-15930

Systems analysis of space manufacturing from nonterrestrial materials

DRIGGERS, G. W. (Science Applications, Inc., Huntsville, Ala.)

(cont. next page)

## DIALOG File 108: AEROSPACE - 82-86/ISS09

International Astronautical Federation, International Astronautical Congress, 28th, Prague, Czechoslovakia, Sept. 25-Oct. 1, 1977, 34 p.

Publication Date: Sep. 1977 16 Refs.

Report No.: IAF PAPER 77-72

Language: English

Country of Origin: United States Country of Publication: International Organization

Document Type: CONFERENCE PAPER

Most documents available from AIAA Technical Library

Journal Announcement: IAA7804

The components of a general system for obtaining nonterrestrial material and processing it to a finished product are described conceptually. A chemical process system for lunar materials is schematically portrayed, and parameters of the system are estimated. Scenarios for the implementation of the manufacturing facility and production of the early solar power satellites are discussed. Preliminary analysis suggests that large quantities of solar power can be supplied to the earth at less than \$1000 per kilowatt of installed ground capacity. (M.L.)

Source of Abstract/Subfile: AIAA/TIS

Descriptors: \*EXTRATERRESTRIAL RESOURCES; \*SPACE MANUFACTURING; \*SYSTEMS ANALYSIS; CHEMISTRY; LUNAR ROCKS; SATELLITE SOLAR POWER STATIONS; SPACE STATIONS

Subject Classification: 7512 .Astronautics--General (1975-)

0868293 A78-11576

Space processing payloads - A requirements overview

HAMMEL, R. L.; GILLIAM, A. S.; WALTZ, D. M. (TRW Systems Group, Redondo Beach, Calif.)

British Interplanetary Society, Journal (Space Technology), vol. 30, Oct. 1977, p. 363-377.

Publication Date: Oct. 1977 10 Refs.

Language: English

Country of Origin: United States Country of Publication: United Kingdom

Document Type: JOURNAL ARTICLE

Most documents available from AIAA Technical Library

Journal Announcement: IAA7802

Attention is given to Space Processing Applications (SPA) with regard to the user community which will be primarily supported by NASA. The development of a series of low-gravity materials processing experiments (including crystal growth, solidifications, and processes in fluids) is described along with the program requirements for such research. Spacelab/SPA ground operations are discussed, noting SPA equipment integration into subelements, and prelaunch/post landing data handling and processing. A review is presented of an eight-month Space Processing Payload Equipment study which defines and investigates SPA payloads for the Space Shuttle, and which includes studies of SPA payload design criteria, mission planning, and analyses regarding costs and scheduling.

Areas of immediate challenges are identified, such as the creation of an apparatus inventory, the definition of alternatives in payload design studies, and cost analyses. (

S.C.S.)

Source of Abstract/Subfile: AIAA/TIS

Descriptors: \*SPACE PROCESSING; \*SPACE SHUTTLES; \*SPACELAB PAYLOADS; COST ANALYSIS; CRYSTAL GROWTH; MISSION PLANNING; SPACE MANUFACTURING

Subject Classification: 7512 .Astronautics--General (1975-)

0845983 N77-13094

Possibilities for industrial material production and processing techniques in space from the mechanical engineering point of view

HAU, E.; LEVEN, P.

Maschinenfabrik Augsburg-Nuernberg A.G., Munich (West Germany). Neue Technologie.

Corp. Source Code: MI971840

Place of Publication: Bonn Publisher: Bundesmin. fuer Forsch. u. Technol.

Publication Date: Apr. 1976 43P.

Report No.: BMFT-FB-W-76-03

Contract No.: BMFT-WRT-1074; GFW-RV-21-V-47/74

Language: MULTIPLE; In GERMAN; ENGLISH summary

Country of Origin: Germany, Federal Republic of Country of Publication: Germany, Federal Republic of

Document Type: REPORT

Most documents available from AIAA Technical Library

Other Availability: NTIS HC A03/MF A01

Journal Announcement: STAR7704

An investigation carried out within the GHM Engineering Group into possible industrial applications for Spacelab resulted in 22 proposals. Following more detailed discussion, 8 of these proposals were selected, and certain basic requirements for their industrial application in the near future are given. These proposals can be separated into two groups: industrial heat-treatment and casting techniques for highly stressed precision machine components (e.g. turbine blades) and production of nonmetallic composite materials. Before any definitive conclusions regarding the suitability of these proposals can be reached, more detailed technological feasibility studies are necessary. (Author (ESA))

Source of Abstract/Subfile: ESA

Descriptors: \*MECHANICAL ENGINEERING; \*SPACE MANUFACTURING; \*SPACELAB; CARBON FIBERS; CASTING; COMPOSITE MATERIALS; HEAT TREATMENT; HOT WORKING; INDUSTRIES; PRODUCTION ENGINEERING; REINFORCING FIBERS; TURBINE BLADES

Subject Classification: 7512 .Astronautics--General (1975-)

0842705 A77-51412

Space factories (technology assessment)

WALTZ, D. M.; HAMMEL, R. L. (TRW Defense and Space Systems Group, Redondo Beach, Calif.)

International Astronautical Federation, International Astronautical Congress, 28th, Prague, Czechoslovakia, Sept. 25-Oct. 1, 1977, 28 p.

(cont. next page)

DIALOG File 108: AEROSPACE - 82-88/ISS09

Publication Date: Sep. 1977 6 Refs.

Report No.: IAF PAPER 77-56

Language: English

Country of Origin: United States Country of Publication: International Organization

Document Type: CONFERENCE PAPER

Most documents available from AIAA Technical Library

Journal Announcement: IAA7724

The technical and business aspects of space manufacturing are discussed. Advantages of space factories and of the low-gravity environment in space are summarized, and five basic types of space processes are examined: crystal growth, purification and separation of various materials, mixing of immiscible and composite materials, solidification, and process in fluids concerned with chemical reactions and reaction rates or physical and thermodynamic phenomena. Steps in the evolution of a space-manufacturing program are outlined, and previous experiments in space processing are described along with proposed Space Transportation System/Spacelab space-processing payloads. Three case studies representative of future commercial space-processing activities are reviewed, some practical features of a space factory are considered, and the reality of the space-factory program is assessed. (F.G.M.)

Source of Abstract/Subfile: AIAA/TIS

Descriptors: \*INDUSTRIAL PLANTS; \*LOW GRAVITY MANUFACTURING \*SPACE MANUFACTURING; \*TECHNOLOGY ASSESSMENT; CRYSTAL GROWTH; METALLURGY; SPACE PROCESSING; SPACELAB

Subject Classification: 7512 .Astronautics--General (1975-)

0832865 A77-41568

Satellite power system LEO vs GEO assembly issues ( construction in Low Earth Orbits vs Geosynchronous Orbits) MOCKOVCIAK, J., JR.; ADORNATO, R. J. (Grumman Aerospace Corp., Bethpage, N.Y.)

Grumman Aerospace Corp., Bethpage, N.Y.

Corp. Source Code: G6919090

In: New options in energy technology; Proceedings of the Conference, San Francisco, Calif., August 2-4, 1977. (A77-41551 19-44) New York, American Institute of Aeronautics and Astronautics, Inc., 1977, p. 124-132.

Publication Date: 1977 6 Refs.

Report No.: AIAA 77-1029

Contract No.: NAS8-31308

Language: English

Country of Origin: United States Country of Publication: United States

Document Type: CONFERENCE PAPER

Journal Announcement: IAA7719

A strawman crystal-silicon 5-GW Satellite Power System (SPS) concept formed the basis of a study of construction concepts for building a complete SPS in low earth orbit (LEO) or geosynchronous orbit (GEO). Construction scenarios were evolved, including factory-in-space concepts and operations. Design implications imposed on the SPS satellite as a consequence of in-orbit assembly operations, and related

attitude control requirements during assembly in LEO or GEO environments, were also evaluated. Results are presented indicating that complete assembly of an operational SPS in LEO, followed by transport to GEO, does not appear technically desirable. The best mix, however, of LEO versus GEO construction activity remains to be resolved. ((Author))

Descriptors: \*ASSEMBLIES; \*MICROWAVE ANTENNAS; \*SATELLITE ORBITS; \*SOLAR ARRAYS; \*SPACE MANUFACTURING; \*SPACECRAFT POWER SUPPLIES; ANTENNA DESIGN; EARTH ORBITS; ELECTRIC POWER SUPPLIES; POINTING CONTROL SYSTEMS; SATELLITE ANTENNAS; STATIONARY ORBITS; STRUCTURAL DESIGN; TRUSSES

Subject Classification: 7512 .Astronautics--General (1975-)

0827383 A77-36086

Space processing program of the National Bureau of Standards PARKER, R. L. (National Bureau of Standards, Metallurgy Div., Washington, D.C.)

(COSPAR, Symposium on Materials Sciences in Space, Philadelphia, Pa., June 9, 10, 1976.) In: Materials sciences in space with application to space processing. (A77-36076 16-12) New York, American Institute of Aeronautics and Astronautics, Inc., 1977, p. 423-435.

Publication Date: 1977

Report No.: PR-275623

Language: English

Country of Origin: United States Country of Publication: United States

Document Type: COLLECTED WORK

Journal Announcement: IAA7716

The work of the National Bureau of Standards (NBS) for NASA's space processing program is described. The general emphasis of the NBS work has been on ground-based studies of those aspects of space which possibly could provide a unique environment for making materials more perfect or more pure. Individual projects on crystal perfection in melt growth, evaporative purification, composites, melt shape, vapor transport, and surface traction are described. ((Author))

Descriptors: \*CRYSTAL GROWTH; \*MATERIALS SCIENCE; \*SPACE PROCESSING; COMPOSITE MATERIALS; LOW GRAVITY MANUFACTURING; REDUCED GRAVITY; SPACE MANUFACTURING; VAPOR DEPOSITION; WEIGHTLESSNESS

Subject Classification: 7526 .Metallic Materials (1975-)

0827380 A77-36083

Survey of the microgravity program in the Federal Republic of Germany

BEWERSDORFF, A. (Deutsche Forschungs- und Versuchsanstalt fuer Luft- und Raumfahrt, Cologne, West Germany)

(COSPAR, Symposium on Materials Sciences in Space, Philadelphia, Pa., June 9, 10, 1976.) In: Materials sciences in space with application to space processing. (A77-36076 16-12) New York, American Institute of Aeronautics and Astronautics, Inc., 1977, p. 347-354.

(cont. next page)

## DIALOG File 108: AEROSPACE - 62-86/ISS09

Publication Date: 1977

Language: English

Country of Origin: Germany, Federal Republic of Country of

Publication: United States

Document Type: COLLECTED WORK

Journal Announcement: IAA7716

The prospect of experiments under microgravity has stimulated considerable interest in the FRG. Presently 150 experiments have been proposed. Most of them are aimed at gaining new insight into material processes such as nucleation or solidification, or at obtaining improved data of material properties. The program includes experiments in the fields of metallurgy, crystal growth, chemistry, physical chemistry, fluid dynamics, and it relates even to biology and biophysics.

Experiments have been conducted aboard Apollo-Soyuz and NASA rockets. More rocket flights are planned over the next years.

((Author))

Descriptors: \*EUROPEAN SPACE PROGRAMS; \*LOW GRAVITY MANUFACTURING; \*SPACE PROCESSING; \*WEST GERMANY; CRYSTAL GROWTH; MATERIALS SCIENCE; METALLURGY; NUCLEATION; SOLIDIFICATION; SPACE MANUFACTURING

Subject Classification: 7512 .Astronautics--General (1975-)

0827376 A77-36079

Capillary phenomena in microgravity

HAYNES, J. M. (Bristol, University, Bristol, England)

(COSPAR, Symposium on Materials Sciences in Space, Philadelphia, Pa., June 9, 10, 1976.) In: Materials sciences in space with application to space processing. (A77-36076 16-12) New York, American Institute of Aeronautics and Astronautics, Inc., 1977, p. 57-66.

Publication Date: 1977 8 Refs.

Language: English

Country of Origin: United Kingdom Country of Publication: United States

Document Type: COLLECTED WORK

Journal Announcement: IAA7716

The paper examines the general conditions for the static capillary equilibrium of a fluid interface and for the stability of such equilibrium. Attention is given to capillary phenomena in microgravity in general, and to the utilization of capillary phenomena on Spacelab for space processing, in particular. The maintenance of stable molten zones during crystal growth experiments is considered. (B.J.)

Source of Abstract/Subfile: AIAA/TIS

Descriptors: \*CAPILLARY FLOW; \*LOW GRAVITY MANUFACTURING; \*SPACE PROCESSING; MATERIALS SCIENCE; SPACE MANUFACTURING; TECHNOLOGY UTILIZATION

Subject Classification: 7512 .Astronautics--General (1975-)

0827375 A77-36078

Electrophoresis (in microgravity environment)

BIER, M. (U.S. Veterans Administration Hospital, Tucson, Ariz.)

Veterans Administration Hospital, Tucson, Ariz.

Corp. Source Code: V0665372

In: Materials sciences in space with application to space processing. (A77-36076 16-12) New York, American Institute of Aeronautics and Astronautics, Inc., 1977, p. 41-55.

Publication Date: 1977 31 Refs.

Contract No.: NAS8-29566

Language: English

Country of Origin: United States Country of Publication: United States

Document Type: ANALYTIC OF COLLECTED WORK

Journal Announcement: IAA7716

Ground-based techniques for electrophoresis take account of the need either to circumvent the effects of gravity to prevent convection, or to use gravity for fluid stabilization through artificial density gradients. The microgravity environments of orbiting spacecraft provides a new alternative for electrophoresis by avoiding the need for either of these two approaches. The paper presents some theoretical considerations concerning electrophoresis, examines certain experimental techniques (zone and high density gel electrophoresis, isoelectric focusing and isotachopheresis), and examines the electrophoresis of living cells. (B.J.)

Source of Abstract/Subfile: AIAA/TIS

Descriptors: \*ELECTROPHORESIS; \*LOW GRAVITY MANUFACTURING; \*SPACE PROCESSING; FREE CONVECTION; GRAVITATIONAL EFFECTS; MEDICAL EQUIPMENT; MOLECULAR BIOLOGY; SPACE MANUFACTURING

Subject Classification: 7525 .Inorganic &amp; Physical Chemistry (1975-)

0824896 A77-33599

The promise of the space factory

WALTZ, D. M. (TRW Defense and Space Systems Group, Redondo Beach, Calif.)

Technology Review, vol. 79, May 1977, p. 38-48.

Publication Date: May 1977 20 Refs.

Language: English

Country of Origin: United States Country of Publication: United States

Document Type: JOURNAL ARTICLE

Most documents available from AIAA Technical Library

Journal Announcement: IAA7715

Processes and products well suited to low-gravity conditions, organization and construction of space factories on the basis of Spacelab modules, program costs, and early payoffs and benefits from space manufacturing (aside from special products and processes) are discussed. Levitation, positioning of products with the aid of minimum fields, containerless and contactless high-purity processing, and reliance on cohesion and adhesion as process-controlling factors in the manufacture and processing of either inert or biological materials in a Spacelab environment are dealt with.

A list of likely electronic products, optical products, biological products, and structural materials is presented. Special attention is given to the manufacture of perfect (cont. next page)

ORIGINAL PAGE IS  
OF POOR QUALITY



## DIALOG File 108: AEROSPACE - 82-88/ISS09

crystals, glass fibers, silicon ribbon, laser glass, and electrophoretic isolation of biological cells. (R.D.V.)

Source of Abstract/Subfile: AIAA/TIS

Descriptors: \*INDUSTRIAL PLANTS; \*LARGE SPACE STRUCTURES; \*LOW GRAVITY MANUFACTURING; \*SPACE MANUFACTURING; COST ESTIMATES; EXTRATERRESTRIAL RESOURCES; OPTICAL EQUIPMENT; SPACE SHUTTLES; SPACE STATIONS; SPACELAB; WEIGHTLESSNESS

Subject Classification: 7512 .Astronautics--General (1975-)

0820327 A77-29030

How do U.S. companies view space industrialization

DULA, A. M. (Butler, Binion, Rice, Cook and Knapp; Houston, University, Houston, Tex.)

Astronautics and Aeronautics, vol. 15, Apr. 1977, p. 44-46.

Publication Date: Apr. 1977

Language: English

Country of Origin: United States Country of Publication: United States

Document Type: JOURNAL ARTICLE

Most documents available from AIAA Technical Library

Journal Announcement: IAA7712

Results from a questionnaire on space industrialization sent to chief executive officers of 378 American companies are discussed. Twenty percent of the companies returned the questionnaire completed. The average company responding to the questionnaire had annual gross sales of \$2.5 billion. Some 30% of the respondents were aware of and interested in the possibility of solar power satellites and communication satellites. Forty-seven percent of the respondents felt that there was some probability of both their industries and their companies becoming involved in a Shuttle-based program. (A.Y.)

Source of Abstract/Subfile: AIAA/TIS

Descriptors: \*INDUSTRIES; \*SPACE MANUFACTURING; \*SPACE PROCESSING; COMMUNICATION SATELLITES; CRYSTAL GROWTH; ECONOMIC FACTORS; GOVERNMENT/INDUSTRY RELATIONS; METALLURGY; SATELLITE SOLAR POWER STATIONS; SPACE SHUTTLES

Subject Classification: 7580 .Social Sciences--General (1975-)

DIALOG File 108: AEROSPACE - 82-88/ISS09

0810064 A77-18759

**Space processing applications - Designing the initial space transportation payload capability**

HAMMEL, R. L. (TRW Systems, Redondo Beach, Calif.)

Raumfahrtforschung, vol. 20, Nov.-Dec. 1976, p. 264-272.

Publication Date: Dec. 1976 7 Refs.

Language: English

Country of Origin: United States Country of Publication: Germany, Federal Republic of

Document Type: JOURNAL ARTICLE

Most documents available from AIAA Technical Library

Journal Announcement: IAA7706

A description is presented of the U.S. Space Processing Applications program which has been established under the auspices of NASA. Material processes considered are related to crystal growth, purification/separation, mixing, solidification, and processes in fluids. Program requirements are examined, taking into account fundamentals, research and development payload equipment design efforts, facility summaries, design payloads, and a mission model. It is pointed out that Spacelab sortie flights offer the opportunity to initiate a comprehensive research and development phase in the exploitation of near weightless conditions for processing materials. (G.R.)

Source of Abstract/Subfile: AIAA/TIS

Descriptors: \*INSTRUMENT PACKAGES; \*MISSION PLANNING; \*NASA PROGRAMS; \*SPACE PROCESSING; \*SPACE SHUTTLES; FURNACES; PAYLOADS; RESEARCH AND DEVELOPMENT; SATELLITE-BORNE INSTRUMENTS; SPACE MANUFACTURING

Subject Classification: 7512 Astronautics--General (1975-)

0809564 A77-18259

**The construction of satellite solar power stations from non-terrestrial materials**

OLEARY, B. (Princeton University, Princeton, N.J.)

American Institute of Aeronautics and Astronautics, Annual Meeting and Technical Display Incorporating the Forum on the Future of Air Transportation, 13th, Washington, D.C., Jan. 10-13, 1977, 6 p.

Publication Date: Jan. 1977 8 Refs.

Report No.: AIAA PAPER 77-354

Language: English

Country of Origin: United States Country of Publication: United States

Document Type: CONFERENCE PAPER

Most documents available from AIAA Technical Library

Journal Announcement: IAA7706

The principal results are discussed of a summer study conducted in 1976 at the NASA Ames Research Center. The study had been concerned with the key technical problems which would have to be resolved to make a space manufacturing of lunar materials feasible. Attention is given to the lunar mass driver as a means of transporting large quantities of lunar material to a precise point in space, three-body calculations of trajectories for lunar materials launched by mass driver from the moon to L2 and from L2 to convenient space

manufacturing sites, the chemical processing of the materials, and questions concerning construction, cost, and schedule. Mass driver reaction engines are also considered along with the utilization of earth-approaching asteroids as raw materials for space manufacturing. (G.R.)

Source of Abstract/Subfile: AIAA/TIS

Descriptors: \*ORBITAL ASSEMBLY; \*SATELLITE SOLAR POWER STATIONS; \*SPACE MANUFACTURING; \*SPACECRAFT CONSTRUCTION MATERIALS; ASTEROIDS; COST REDUCTION; ENERGY TECHNOLOGY; FEASIBILITY ANALYSIS; SPACE COLONIES; SPACE TUGS

Subject Classification: 7512 Astronautics--General (1975-)

0793539 N76-26246

**Possibilities of manufacturing, and of scientific research in the space environment, and effective realization thereof (literature study)**

studie ueber die moeglichkeiten der fertigung bzw. der durchfuehrung von wissenschaftlichen untersuchungen unter weltraumbedingungen und ueber deren zweckmaessige gestaltung (literaturstudie)

BECK, R.; GRUENTHALER, K. H.; GAAR, H.; HUMS, D.; MUELLER, U.; SCHANZ, G.; SETHNA, D.; WINTER, H.

Battelle Inst., Frankfurt am Main (West Germany).

Corp. Source Code: BE016121

Place of Publication: Bonn Publisher: Bundesmin. fuer Forsch. u. Technol.

Publication Date: Dec. 1975 208P.

Report No.: BMFT-FB-W-75-24

Contract No.: BMFT-WRT-1073; GFW-RV-21-V-10/73

Language: MULTIPLE; In GERMAN; ENGLISH summary

Country of Origin: Germany, Federal Republic of Country of Publication: Germany, Federal Republic of

Document Type: REPORT

Most documents available from AIAA Technical Library

Other Availability: NTIS

Journal Announcement: STAR7617

Ideas for carrying out space experiments in the fields of materials science and biology as well as the results of experiments conducted during the Apollo 14 and the Skylab missions are summarized. Available literature published up to February 1974 was studied. Important aspects are emphasized for planning future experiments in the fields of ceramics, metals and alloys, composites, single crystals, and biological processes for which space manufacturing appears to be particularly interesting. (Author (ESA))

Source of Abstract/Subfile: ESA

Descriptors: \*AEROSPACE ENVIRONMENTS; \*RESEARCH AND DEVELOPMENT; \*SPACE LABORATORIES; \*SPACE MANUFACTURING; \*SUMMARIES; ALLOYS; APOLLO 14 FLIGHT; CERAMICS; COMPOSITE MATERIALS; ELECTROPHORESIS; GLASS; LITERATURE; METALS; SINGLE CRYSTALS; SKYLAB PROGRAM

Subject Classification: 7512 Astronautics--General (1975-)

## DIALOG File 108: AEROSPACE - 82-88/ISS09

0790437 N76-23100

**Zero-G processing of magnets experiment MA-070**

LARSON, D. J., JR.

Grumman Aerospace Corp., Bethpage, N.Y.

Corp. Source Code: G6919090

In NASA, Lyndon B. Johnson Space Center Apollo-Soyuz Test

Project 13 p (SEE N76-23074 13-88)

Publication Date: Feb. 1976

Language: English

Country of Origin: United States Country of Publication:  
United States

Document Type: REPORT

Most documents available from AIAA Technical Library

Journal Announcement: STAR7613

Solidification of magnetic materials in the low gravity orbital environment was studied. The magnetic compounds under study, manganese bismuth and copper cobalt cerium ((Cu, Co)5Ce), both have the potential for the development of high coercive strength. Preliminary results indicate that static fluid configurations, in the absence of the gravitational body force, differ substantially from the documented terrestrial behavior. Chemical homogeneity is substantially enhanced on a macroscopic and microscopic level. Single crystal matrices have been grown in the coordinated growth regions of the flight samples. Primary crystals one order of magnitude greater than those grown terrestrially have been noted and are limited in size by the ampoule dimensions. (Author)

Descriptors: \*APOLLO SOYUZ TEST PROJECT; \*MAGNETIC MATERIALS; \*REDUCED GRAVITY; \*SPACE MANUFACTURING; BISMUTH ALLOYS; CERIUM; COBALT ALLOYS; COPPER ALLOYS; MANGANESE ALLOYS; SOLIDIFICATION

Subject Classification: 7512 .Astronautics--General (1975-)

COSATI Code: 20C .Electricity &amp; Magnetism

0785606 N76-18183

**Processing eutectics in space**

Summary Report

DOUGLAS, F. C.; GALASSO, S. F.

United Technologies Research Center, East Hartford, Conn.

Corp. Source Code: UW324219

Publication Date: Nov. 1975 72P.

Report No.: NASA-CR-144196; R75-911721-10

Contract No.: NAS8-29669

Language: English

Country of Origin: United States Country of Publication:  
United States

Document Type: REPORT

Most documents available from AIAA Technical Library

Other Availability: NTIS

Journal Announcement: STAR7609

The investigations of directional solidification have indicated the necessity of establishing a secure foundation in earth-based laboratory processing in order to properly assess low-gravity processing. Emphasis was placed on evaluating the regularity of microstructure of the rod-like eutectic Al-A13Ni obtained under different conditions of growth involving the

parameters of thermal gradient, solidification rate, and interfacial curvature. In the case of Al-A13Ni, where the A13Ni phase appears as facets rods, solidification rate was determined to be a controlling parameter. Zone melting of thin eutectic films showed that for films of the order of 10 to 20 micrometers thick, the extra surface energy appears to act to stabilize a regular microstructure. The results suggest that the role of low-gravity as provided in space-laboratory processing of materials is to be sought in the possibility of generating a higher thermal gradient in the solidifying ingot for a given power input-output arrangement than can be obtained under normal one-g processes. (Author)

Descriptors: \*EUTECTICS; \*SOLIDIFICATION; \*SPACE MANUFACTURING; ALUMINUM ALLOYS; MICROSTRUCTURE; NICKEL ALLOYS SURFACE ENERGY; THIN FILMS

Subject Classification: 7512 .Astronautics--General (1975-)

COSATI Code: 13H .Industrial Processes

0778742 N76-11191

**Furnace and support equipment for space processing (space manufacturing - Czochralski method)**

Final Report

MAZELSKY, R.; DUNCAN, C. S.; SEIDENSTICKER, R. G.; JOHNSON, R. A.; HOPKINS, R. H.; ROLAND, G. W.

Westinghouse Research Labs., Pittsburgh, Pa.

Corp. Source Code: WW351626

Publication Date: Feb. 1975 66P.

Report No.: NASA-CR-144027

Contract No.: NAS8-30289

Language: English

Country of Origin: United States Country of Publication:  
United States

Document Type: REPORT

Most documents available from AIAA Technical Library

Other Availability: NTIS

Journal Announcement: STAR7602

A core facility capable of performing a majority of materials processing experiments is discussed. Experiment classes are described, the needs peculiar to each experiment type are outlined, and projected facility requirements to perform the experiments are treated. Control equipment (automatic control) and variations of the Czochralski method for use in space are discussed. (Author)

Descriptors: \*CZOCHEVALSKI METHOD; \*FURNACES; \*SPACE MANUFACTURING; \*TECHNOLOGY ASSESSMENT; AUTOMATIC CONTROL; CONTAINERLESS MELTS; CRYSTALLIZATION; EXPERIMENTATION; LABORATORY EQUIPMENT; SPACE MISSIONS

Subject Classification: 7512 .Astronautics--General (1975-)

COSATI Code: 13H .Industrial Processes

## DIALOG File 108: AEROSPACE - 82-88/ISS09

0766908 A76-19324

NASA seeks industry space processors  
; et al.Aviation Week and Space Technology, vol. 104, Jan. 26, 1976,  
p. 46, 47, 49 (5 ff.).

Publication Date: Jan. 1976

Language: English

Country of Publication: United States

Document Type: JOURNAL ARTICLE

Most documents available from AIAA Technical Library

Journal Announcement: IAA7607

The economic and technological feasibility of processing special-purpose materials under zero-gravity outer space conditions in the Space Shuttle program is examined and reviewed. Materials research can be advanced profoundly when gravity effects are eliminated as contributing factors. Gravity convection in melting and solidification interferes with complete homogenization. Drugs and vaccines can be produced via zero-g electrophoresis; glass fiber and crystal growth potentialities are impressive. Levitation (containerless) melting of tungsten, solar furnaces and multiple furnaces hold forth promise. Planning, costs, participation of private firms, ground support, intensification of normal earth-based research on materials considered for space processing, and logistics problems are also discussed. (R.D.V.)

Source of Abstract/Subfile: AIAA/TIS

Descriptors: \*FEASIBILITY ANALYSIS; \*NASA PROGRAMS; \*SPACE MANUFACTURING; \*WEIGHTLESSNESS; COST EFFECTIVENESS; CRYSTAL GROWTH; ELECTROPHORESIS; GLASS FIBERS; GOVERNMENT PROCUREMENT LOGISTICS MANAGEMENT; MELTING; SOLIDIFICATION; SPACE SHUTTLES

Subject Classification: 7512 .Astronautics--General (1975-)

0756718 N75-33127

Economic analysis of materials processing in space

Final Report, Mar. 1974 - Jun. 1975

VACHON, R. I.; WILCOX, R. C.; LACY, A. W.; HALE, C. W.;  
BECKETT, S. D.; CANTERBERRY, J. B.

Auburn Univ., Ala. Engineering Experiment Station.

Corp. Source Code: AB528793

Publication Date: Jun. 1975 265P.

Report No.: NASA-CR-143965

Contract No.: NAS8-29881

Language: English

Country of Origin: United States Country of Publication:  
United States

Document Type: REPORT

Most documents available from AIAA Technical Library

Other Availability: NTIS

Journal Announcement: STAR7524

The cost benefits and the feasibility of processing turbine blades, electrophoresis, and crystals in space were studied.

&For individual titles, see N75-33128 through N75-33135.

Descriptors: \*ECONOMIC ANALYSIS; \*SPACE MANUFACTURING; COST ANALYSIS; CRYSTAL GROWTH; ELECTROPHORESIS; FEASIBILITY ANALYSIS; SPACE SHUTTLES; TURBINE BLADES

Subject Classification: 7512 .Astronautics--General (1975-)  
COSATI Code: 22A .Astronautics

0743114 N75-19311

Specific problems of electrophoresis in space

PEETERS, H.

Simon Stevin Instituut voor Wetenschappelijk Onderzoek,  
Brugge (Belgium).

Corp. Source Code: SL687243

In ESRO Process. and Manufacturing in Space p 273-278 (SEE  
N75-19285 11-12)

Publication Date: Jul. 1974

Language: English

Country of Origin: Belgium Country of Publication:  
International Organization

Document Type: CONFERENCE PAPER

Most documents available from AIAA Technical Library

Journal Announcement: STAR7511

Advantages and problems of spaceborne electrophoresis resulting from weightless operation are discussed. The absence of convection due to density gradient is an advantage of unquestionable value with several electrophoretic procedures in space. For continuous preparation electrophoretic methods, gravity is useful in the separation process. The possibility of space separation of living cells requires the solution of a set of logistics problems that occur before, during, and after the separation procedure itself. A real advantage of space lies in a domain where gravity interferes with the electrophoretic principle through viscosity. Absence of gravity removes the normal damping effects to slight disturbing forces such as electroosmosis, noise-generated convection, and small acceleration gradients due to the movement of the separation cell. (ESRO)

Source of Abstract/Subfile: ESA

Descriptors: \*AEROSPACE ENVIRONMENTS; \*ELECTROPHORESIS;  
\*REDUCED GRAVITY; \*SPACE MANUFACTURING; CELLS (BIOLOGY);  
CONVECTION; ONBOARD EQUIPMENT; SEPARATORS

Subject Classification: 7512 .Astronautics--General (1975-)

0743111 N75-19308

Electronic materials: Purification and space conditions

RODOT, H.

Centre National de la Recherche Scientifique, Meudon  
(France).

Corp. Source Code: CL668139

In ESRO Process. and Manufacturing in Space p 243-246 (SEE  
N75-19285 11-12)

Publication Date: Jul. 1974

Language: English

Country of Origin: France Country of Publication:  
International Organization

Document Type: CONFERENCE PAPER

Most documents available from AIAA Technical Library

(cont. next page)

## DIALOG File 108: AEROSPACE - 82-86/ISS09

Journal Announcement: STAR7511

Problems concerning the purity of electronic materials including contaminationless ultra-purification and crystal-growth processes are described. Usual terrestrial purification methods are outlined and the influence of gravity on the results obtained is analyzed. Space conditions, space vacuum and zero gravity, relevant to purification techniques are analyzed. The possibilities for applying these conditions to improve known methods, floating zone technique, or to achieve new space processes are evaluated. (Author (ESRO))

Source of Abstract/Subfile: ESA

Descriptors: \*AEROSPACE ENVIRONMENTS; \*CRYSTAL GROWTH; \*PURIFICATION; \*REDUCED GRAVITY; \*SEMICONDUCTORS (MATERIALS); ELECTRONICS; SPACE MANUFACTURING

Subject Classification: 7576 .Solid-State Physics (1975-)

0743107 N75-19304

Space processing economics

BREDT, J. H.

National Aeronautics and Space Administration, Washington, D. C.

Corp. Source Code: NC452981

In ESRO Process. and Manufacturing in Space p 205-208 (SEE N75-19285 11-12)

Publication Date: Jul. 1974.

Language: English

Country of Origin: United States Country of Publication:

International Organization

Document Type: CONFERENCE PAPER

Most documents available from AIAA Technical Library

Journal Announcement: STAR7511

Two types of space processing operations may be considered economically justified; they are manufacturing operations that make profits and experiment operations that provide needed applied research results at lower costs than those of alternative methods. Some examples from the Skylab experiments suggest that applied research should become cost effective soon after the space shuttle and Spacelab become operational. In space manufacturing, the total cost of space operations required to process materials must be repaid by the value added to the materials by the processing. Accurate estimates of profitability are not yet possible because shuttle operational costs are not firmly established and the markets for future products are difficult to estimate. However, approximate calculations show that semiconductor products and biological preparations may be processed on a scale consistent with market requirements and at costs that are at least compatible with profitability using the Shuttle/Spacelab system. (Author (ESRO))

Source of Abstract/Subfile: ESA

Descriptors: \*COST EFFECTIVENESS; \*ECONOMICS; \*SPACE MANUFACTURING; SEMICONDUCTORS (MATERIALS); SKYLAB PROGRAM; SPACE SHUTTLES; SPACELAB

Subject Classification: 7583 .Economics &amp; Cost Analysis (1975-)

0743105 N75-19302

Space processing of ceramic materials

SAVAGE, C. H.; LEIPOLO, M. H.

Jet Propulsion Lab., California Inst. of Tech., Pasadena, Corp. Source Code: JJ574450

In ESRO Process. and Manufacturing in Space p 191-197 (SEE N75-19285 11-12)

Publication Date: Jul. 1974

Contract No.: NAS7-100

Language: English

Country of Origin: United States Country of Publication:

International Organization

Document Type: CONFERENCE PAPER

Most documents available from AIAA Technical Library

Journal Announcement: STAR7511

A review was made of the processing of ceramic materials in space and of those space environment factors appearing to be useful in the processing of this class of materials. Applicability of these factors to various processing procedures appropriate to ceramics, such as containerless melting, is discussed. Specific applications of these procedures in developing new and improved products and processes are reviewed. (ESRO)

Source of Abstract/Subfile: ESA

Descriptors: \*AEROSPACE ENVIRONMENTS; \*CERAMICS; \*REDUCED GRAVITY; \*SPACE MANUFACTURING; CONTAINERLESS MELTS; PRODUCT DEVELOPMENT

Subject Classification: 7527 .Nonmetallic Materials (1975-)

ORIGINAL PAGE IS  
OF POOR QUALITY

**ORIGINAL PAGE IS  
OF POOR QUALITY**

**ABI/INFORM DATABASE**

ABI/INFROM, the business database, is a copyrighted product of Data Courier Inc., 620 South Fifth Street, Louisville, Kentucky 40202. Full-text articles of most ABI/INFORM abstracts are available from Data Courier for \$8.25 each. Call 800-626-2832 (U.S.) or 800-626-0307 (Canada) for additional information or to order an article.

**"Page missing from available version"**

*Pages 1 thru 3*

## DIALOG File 15: ABI/Inform - 71-86/May, Week 2 (Copr. Data Courier Inc.1986)

86007963

**Still A-OK: The Promise of Factories in Space**

Dumaine, Brian  
Fortune v113n5 PP: 49-50 Mar 3, 1986 CODEN: FORTAP ISSN:  
0015-8259 JRNL CODE: FOR  
DOC TYPE: Journal Paper LANGUAGE: English LENGTH: 2 Pages  
AVAILABILITY: ABI/INFORM

US companies with space manufacturing ambitions doubt that the recent shuttle disaster will alter long-term plans. In fact, \$18 billion in sky-made product sales by US industry has been predicted for the year 2000. The zero-gravity of space allows manufacturers to: 1. easily rearrange molecules to make new drug compounds, 2. make materials with defect-free crystalline structures, and 3. mix metals to form perfectly blended alloys. An \$8-billion space station, which NASA hopes to place in orbit by 1994, would greatly aid these efforts. Already, McDonnell Douglas has found that space greatly facilitates the production of erythropoietin, a drug that could help anemics. Also, Microgravity Research Associates plans to market space-manufactured gallium arsenide crystals for use in semiconductor chips. A 10-year project by Minnesota Mining & Manufacturing Co. aims to produce and test crystals that could be used in a new kind of optical computer.

DESCRIPTORS: NASA (space); Drugs; Space; Manufacturing; Experiments; Semiconductors; Predictions; R&D

CLASSIFICATION CODES: 8641 (CN=Pharmaceuticals industry); 8650 (CN=Electrical & electronics industries); 5400 (CN=Research & development)

86000123

**Investing in the Final Frontier**

Cohen, Jeffrey  
Financial Planning v14n11 PP: 145-151 Nov 1985 ISSN:  
0746-7915 JRNL CODE: FPN  
DOC TYPE: Journal Paper LANGUAGE: English LENGTH: 5 Pages  
AVAILABILITY: ABI/INFORM

Recent experiments in pharmaceutical manufacturing performed aboard the space shuttle by McDonnell Douglas Astronautics Co. may assist in providing investment funds for private commercial space projects, including satellite operations, which are being shifted to the private sector. Most of the investment opportunities in commercial space projects involve venture capital, joint ventures, or research and development (R&D) limited partnerships, the funding method most likely to be used by Space Industries Inc. David Thompson, president of Orbital Sciences Corp., notes that the investor enthusiasm in start-up companies has declined because returns on investments have not yet been generated. Venture capitalist William Claybaugh believes investment funds can be increased through progress in the materials processed in space industry and government purchase of private space products. The tax and regulatory environments are also likely to affect investments.

DESCRIPTORS: Space; Investments; Satellites; Limited partnerships; Manycompanies; Start up; Companies; R&D

CLASSIFICATION CODES: 3400 (CN=Investment analysis); 8680 (CN=Transportation equipment industry)

85037215

**Promising Industries for Investors**

Moore, Thomas  
Fortune v112n10(Special Issue/Investor's Guide) PP: 88-97  
Fall 1985 CODEN: FORTAP ISSN: 0015-8259 JRNL CODE: FOR  
DOC TYPE: Journal Paper LANGUAGE: English LENGTH: 6 Pages  
AVAILABILITY: ABI/INFORM

Eight industries appear promising for investors through 1986, even in a sluggish economy. Some have potential because of new products and services, while others look good because of takeover action. Defense and space electronics are promising because of strong military spending and takeover activity. Deregulation and takeover action make cable television attractive. The waste disposal industry is benefiting from concern over toxic wastes and a decreasing amount of space left in which to dispose of garbage. Health maintenance organizations are popular as a solution to soaring health care costs and insurance premiums. Pharmaceutical stocks, which traditionally do well in slow markets, are also attractive because of the probable weakening of the dollar and promising new drugs. Takeover activity and improved earnings make regional banks appealing. Anticipation of a rebound in computers will help computer-aided design and engineering stocks, and circuit board manufacturers remain popular.

DESCRIPTORS: Manyindustries; Manycompanies; Economic trends Business conditions; Business growth; Forecasts; Investments

CLASSIFICATION CODES: 1110 (CN=Economic conditions & forecasts); 3400 (CN=Investment analysis)

85032447

**Business Is Starting to Get Serious About Space**

Payne, Seth; Hall, Alan; Helm, Leslie; Ellis, James E.  
Business Week n2913(Industrial/Technology Edition) PP: 76,79  
Sep 23, 1985 CODEN: BUWEA3 ISSN: 0007-7135 JRNL CODE: BWE  
DOC TYPE: Journal Paper LANGUAGE: English LENGTH: 2 Pages  
AVAILABILITY: ABI/INFORM

The successful record of the National Aeronautics and Space Administration's (NASA) space shuttle is finally attracting paid, on-board research and development experiments by private industry. McDonnell Douglas Astronautics Co. and Ortho Pharmaceutical Corp. have an aggressive program to develop drugs in space. The shuttle has already performed 6 experiments for McDonnell Douglas, and the company has identified 6 biological products that would be profitable ventures. Other companies, including 3M Co., Rockwell, Boeing, and General Motors, are now negotiating with NASA for experiments in orbit, and industry flights on the shuttle will double or triple in 1986. This corporate commitment will help NASA to justify building a manned space station by 1994. Support is also emerging from private industry to fund 5 new university Centers for Commercial Development of Space. NASA hopes these university/business labs will prepare experiments for the shuttle that will be ready for scaling up to production when a permanent space station is built in the

(cont. next page)



## DIALOG File 15: ABI/Inform - 71-86/May, Week 2 (Copr. Data Courier Inc. 1986)

1990s. Tables.

DESCRIPTORS: Space; Travel; Commercial; Applications; Drugs R&amp;D; NASA (space); Experiments; Manycompanies; Research centers

CLASSIFICATION CODES: 5400 (CN=Research &amp; development); 9550 (CN=Public sector)

85027266

**Solar Cell Refinements Are Making Possible More Efficient, Reliable Space Applications**

Hirano, Taizo

OEP Office Equipment &amp; Products (Japan) v14n80 PP: 68-69 Jun 1985 CODEN: OEPRA4 ISSN: 0387-5245 JRNL CODE: OEP

DOC TYPE: Journal Paper LANGUAGE: English LENGTH: 2 Pages AVAILABILITY: ABI/INFORM

In Japan, the National Space Development Agency (NASDA) has designated the Sharp Corp. to develop a new, thin solar cell. The cell is made of single-crystal silicon wafers, 55 microns thick. This cell has become one of the 5 kinds of cells registered as devices approved by NASDA; the other cells include a 100-micron and a 200-micron version. Manufacturing thinner cells has given rise to additional problems, including avoiding cracks and raising available effective surface percentage during the processing of the thin wafers. Since electrical output falls in thinner wafers, methods were developed to preserve the output in these wafers. Other improvements that were made include: 1. improvement of power accumulation electrode efficiency, and 2. improvement in incident efficiency through antireflection coating technology. Quality confirmation tests were conducted on the newly developed cells according to the test specifications of NASDA. Tables.

DESCRIPTORS: Solar energy; Generators; Technological change Innovations; Satellites; R&amp;D; Sharp-Japan; Japan; Electronics industry; Case studies

CLASSIFICATION CODES: 9170 (CN=Non-US); 5400 (CN=Research &amp; development); 8650 (CN=Electrical &amp; electronics industries); 9110 (CN=Company specific)

85018347

**Manufacturing in Space: Europe and Japan Prepare for Takeoff**

Wood, Peter; Lenoir, William

International Mgmt (UK) v40n5(Europe Edition) PP: 72-73 May 1985 CODEN: ITMGAT ISSN: 0020-7888 JRNL CODE: IMG

DOC TYPE: Journal Paper LANGUAGE: English LENGTH: 2 Pages AVAILABILITY: ABI/INFORM

The German Spacelab to be carried aboard the US space shuttle in October 1985 and a European-built space platform slated for launch in 1987 are 2 examples of a growing interest in industrial space research on the part of European companies. The orbital environment allows for research and manufacturing efficiency that cannot be matched on Earth. Fields such as electronics, materials processing, and pharmaceuticals stand to benefit most from space research. For instance, joint venture between McDonnell Douglas and Johnson

& Johnson produced a highly valued hormone on a 1984 shuttle flight. Prospective space manufacturers may become involved through their governments. Companies may also deal directly with the US National Aeronautics and Space Administration (NASA), but this means the loss of government supports. Some Japanese firms are forming groups to split the costs of a space program; others are proposing partnerships with US firms.

DESCRIPTORS: Space; Manufacturing; Research; European Space Agency; NASA (space); R&amp;D; Costs; Japan; Europe; Manycompanies CLASSIFICATION CODES: 5400 (CN=Research &amp; development); 9180 (CN=International)

85004983

**The Region's Business Boards the Shuttles to Profit in Space**

Bailey, Douglas M.

New England Business v7n1 PP: 46-48 Jan 7, 1985 CODEN: NENBA3 ISSN: 0164-3533 JRNL CODE: NEN

DOC TYPE: Journal Paper LANGUAGE: English LENGTH: 3 Pages AVAILABILITY: ABI/INFORM

In February 1985, Ludwig van den Berg of EG&G Inc. (Wellesley, Massachusetts) will fly into outer space aboard a National Aeronautics and Space Administration (NASA) space shuttle to perform a series of mercuric iodide crystal growing experiments. This could lead EG&G to develop and market sensitive radioactive isotopes for medical diagnostic kits. A number of New England companies are planning to compete for some of the space station research contracts that will soon be awarded by the government. Texas, Florida, California, and Michigan have already begun aggressive programs to compete for space business, according to the Center for Space Policy. New England has yet to show that its state governments and industry can develop the partnerships needed to compete in this area. The Center estimates that combined gross annual revenues from specific space commercialization efforts will total \$65.3 billion by the year 2000, with the largest developments in pharmaceutical production.

DESCRIPTORS: R&amp;D; NASA (space); Government contracts; Case studies

CLASSIFICATION CODES: 5400 (CN=Research &amp; development); 9550 (CN=Public sector); 9110 (CN=Company specific)

85003933

**Nuclear-Electric Power in Space**

Truscello, Vincent C.; Davis, Herbert S.

IEEE Spectrum v21n12 PP: 58-65 Dec 1984 CODEN: IEESAM ISSN: 0018-9235 JRNL CODE: SPC

DOC TYPE: Journal Paper LANGUAGE: English LENGTH: 8 Pages AVAILABILITY: ABI/INFORM

Nuclear reactor power systems could produce many new applications in space, but design difficulties abound. Among potential space missions requiring large amounts of electricity are an advanced direct-broadcast satellite, an

(cont. next page)

## DIALOG File 15: ABI/Inform - 71-86/May, Week 2 (Copr. Data Courier Inc. 1986)

air-traffic-control radar satellite, and industrial processing. Long-term space exploratory missions would also require new power technologies. Three US government offices, representing the National Aeronautics and Space Administration, the Department of Defense, and the Department of Energy, have formed a joint program. Their objective is to develop the technology required for nuclear reactor space power plants. The SP-100 program was initiated in February 1983, and work should be completed by the early 1990s. Higher power would permit wider orbital spacing, reducing interference at the ground receivers. Large space stations may require a nuclear power system to support materials processing, such as optical fiber production. Table. Graphs. Diagrams. References.

DESCRIPTORS: Nuclear energy; Nuclear reactors; Space; Applications; History; Electricity; Heat transfer  
CLASSIFICATION CODES: 1510 (CN=Energy resources)

84034897

**The \$30 Billion Potential for Making Chemicals in Space**

Anonymous

Chemical Week v135n16 PP: 44-52 Oct 17, 1984 CODEN: CHWKA9  
ISSN: 0009-272X JRNL CODE: CEM  
DOC TYPE: Journal Paper LANGUAGE: English LENGTH: 5 Pages  
AVAILABILITY: ABI/INFORM

The chemical process industry continues to be very excited about the US space program. The near-zero-gravity environment aboard the space shuttle and the space station proposed for completion in 1994 have lured producers of chemicals, semiconductors, pharmaceuticals, metals, and many other products to sign up or begin negotiating research agreements with the National Aeronautics and Space Administration (NASA). Very soon, 3M (St. Paul, Minnesota) is expected to conduct the first series of organic chemistry reactions aboard the space shuttle. Other companies have planned additional experiments in the production of drugs, crystals, and glass. It has been estimated that, because of the potential for technology transfer and spinoff industries, every \$1 spent on basic research in space will generate \$40 worth of economic growth on earth. Manufacturing in space could generate over \$42 billion in sales annually by the year 2000. NASA and the White House are putting the finishing touches on the national space commercialization policy. Chart.

DESCRIPTORS: Chemical industry; Space; R&D; Production; NASA (space); Many companies  
CLASSIFICATION CODES: 8640 (CN=Chemical industry); 5400 (CN=Research & development)

84028775

**Competition: Who'll Win the Race for Profits in Space?**

Kuzela, Lad

Industry Week v222n3 PP: 28-31 Aug 6, 1984 CODEN: IWEEA4  
ISSN: 0039-0895 JRNL CODE: IW  
DOC TYPE: Journal Paper LANGUAGE: English LENGTH: 4 Pages  
AVAILABILITY: ABI/INFORM

Some analysts think the US could lose the head start in the commercial exploitation of space it gained with the Space Shuttle. Short-term financial pressures coupled with extended payoff periods could cause the US to abdicate its leading role to the Europeans and Japanese. While agreeing to participate in US efforts, both Europe and Japan have a goal of independent space-related activities. Even if optimistic projections are not fully met, space industries could be among the fastest-growing activities in the next century. Despite the lack of a firm, long-term US government financial commitment, some 350 US companies have invested in space research and 20 are negotiating with the National Aeronautics & Space Administration on such ventures as: 1. metal formation, 2. electroplating, 3. catalysts, 4. glass alloys, and 5. long-term blood storage. The first space venture to reach commercial production, perhaps by 1987, may be a government-industry effort in electrophoresis. Besides economic issues, political, social, and legal questions could pose problems.

DESCRIPTORS: Earth stations (TC); Communications satellites International; Economic policy

CLASSIFICATION CODES: 1120 (CN=Economic policy & planning); 5250 (CN=Telecommunications systems); 9180 (CN=International)

84027623

**Pharmacy Poised to Enter Age of Made-in-Space Drugs**

White, John P.

Drug Topics v128n15 PP: 94,96 Aug 6, 1984 CODEN: DGTNA7  
ISSN: 0012-6616 JRNL CODE: RXT  
DOC TYPE: Journal Paper LANGUAGE: English LENGTH: 2 Pages  
AVAILABILITY: Medical Economics Co., Box 553, Oradell, NJ 07649

Within the near future, new pharmacologic agents to aid in the treatment of such conditions as diabetes and hemophilia are expected to be produced by pharmaceutical manufacturing operations located in outer space. The shuttle launch scheduled for August 24 will carry McDonnell Douglas Corp. engineer Charles D. Walker, who will begin the Electrophoresis Operations in Space (EOS) project. Using continuous flow electrophoresis, Walker will separate a hormone from a protein solution without the severely limiting effects of gravity on sample yield and purity. After the shuttle returns to earth, Ortho Pharmaceutical Corp., a partner of McDonnell Douglas in the venture, will conduct the animal and human testing of the material manufactured in space. Ortho hopes the product will be ready to distribute commercially by 1987. A much larger, fully automated electrophoresis unit with greatly increased production capacity is planned for a 1985 shuttle flight. By 1988, a full-scale manufacturing plant is expected to be placed in orbit. Diagram.

DESCRIPTORS: Pharmaceutical industry; Experiments; Joint ventures; Research

CLASSIFICATION CODES: 8641 (CN=Pharmaceuticals industry); 5400 (CN=Research & development)

DIALOG File 15: ABI/Inform - 71-86/May, Week 2 (Copr. Data Courier Inc.1986)

84023284

**Industry's First Astronaut**

Kuzela, Lad

Industry Week v221n7 PP: 15-16 Jun. 25, 1984 CODEN: IWEEA4

ISSN: 0039-0895 JRNL CODE: IW

DOC TYPE: Journal Paper LANGUAGE: English LENGTH: 2 Pages

AVAILABILITY: ABI/INFORM

Charles Walker is scheduled to become industry's first astronaut in the first fully automated space factory. Walker is the chief test engineer for the electrophoresis project currently being developed by McDonnell Douglas Corp. The electrophoresis process involves subjecting human and animal substances to an electrical charge to produce increased quantities and purities of particular cells, enzymes, hormones, or proteins. Because of the lack of gravity, space factories can separate more than 700 times more material and attain purity levels 4 times greater than those possible on earth. If the electrophoresis experiments succeed, McDonnell Douglas expects to launch a fully automated pre-commercial factory in 1985. Applications of the electrophoresis materials include the production of certain medicines and the improved isolation and purification of beta cells to aid in diabetes research.

DESCRIPTORS: McDonnell Douglas-St Louis; Aerospace Industry Case studies; Innovations

CLASSIFICATION CODES: 8680 (CN=Transportation equipment industry); 5400 (CN=Research & development); 9110 (CN=Company specific)

84015484

**The IEEE's Crystal Ball**

Holmes, Edith

Data Communications v13n4 PP: 67-68 Apr 1984 CODEN: DACODM

ISSN: 0363-6399 JRNL CODE: DCM

DOC TYPE: Journal Paper LANGUAGE: English LENGTH: 2 Pages

AVAILABILITY: ABI/INFORM

At a recent symposium, members of the Institute of Electrical and Electronics Engineers (IEEE) offered views on data communications' future. To Howard Frank, president and chief executive officer of Contel Information Systems Inc., the communications industry is going through a chaotic period in which the breakup of AT&T, though much discussed and often blamed, is only one element of an approaching crisis. William L. Mayo, vice-president of satellite systems for Comsat General Corp., stated that Comsat, in a joint venture with NBC, is building the second-largest long-distance network in the US. Richard G. Gould, president of Telecommunications Systems, an engineering company, commented that the recent cancellation of the National Aeronautics and Space Administration's (NASA) 20/30 gigahertz satellite program takes away from the ability to demonstrate to the Third World that the US will sponsor the technology that will provide the orbital slots and the spacecraft capacity needed in the future.

DESCRIPTORS: Data communications; Communications industry; Trends; Communications networks; Television broadcasting;

Satellite communications; Satellite systems; Telecommunications

CLASSIFICATION CODES: 8330 (CN=Broadcasting & telecommunications)

84015201

**Flat-Panel Displays: Technology Choices Multiply**

Sherr, Sol

Mini-Micro Systems v17n4 PP: 77 Apr 1984 ISSN: 0364-9342

JRNL CODE: MOD

DOC TYPE: Journal Paper LANGUAGE: English LENGTH: 1 Pages

AVAILABILITY: ABI/INFORM

Over the next few years, any business graphics application where space is at a premium will be a major market for flat-panel displays. Popular applications include portable computers and multiterminal systems for banks and other financial institutions. Based on a forthcoming Frost & Sullivan Inc. study, sales for flat-panel displays will increase at a compounded annual rate of 34% between 1983 and 1987, and then slow to 10% per year through 1992 in constant-dollar terms. By 1992, flat-panel displays will account for about 60% of the display market. Major technology trends to watch involve: 1. light-emitting diodes (LED), 2. thin-film electroluminescence, 3. gas discharge (plasma), 4. liquid-crystal displays (LCD), 5. flat cathode ray tube (CRT) terminals, 6. incandescence, 7. electromechanical displays, and 8. electrochromics and electrophoretics. Table.

DESCRIPTORS: Flat; Panels; Displays; Markets; Technology; Electronics industry

CLASSIFICATION CODES: 5230 (CN=Computer hardware)

84003456

**Solid State Integrated Circuits: The Case for Gallium Arsenide**

Eden, Richard C.; Livingston, Anthony R.; Welch, Bryant M.

IEEE Spectrum v20n12 PP: 30-37 Dec 1983 CODEN: IEESAM ISSN:

0018-9235 JRNL CODE: SPC

DOC TYPE: Journal Paper LANGUAGE: English LENGTH: 8 Pages

AVAILABILITY: ABI/INFORM

Because of its energy-band structure, gallium arsenide (GaAs) is an ideal medium for electronics circuitry. The GaAs semiconductor holds significant promise for high-speed computers, and manufacturing problems are now beginning to be overcome. Electrons in GaAs are very "light" and highly mobile, and the effective mass of its electrons is only 7% that of electrons in silicon. Electron mobility in the channels of GaAs field-effect transistors (FET) is about an order of magnitude higher than in silicon FETs. GaAs is suited for a wide range of applications, such as high data-rate communications, wide-bandwidth instrumentation, and high-speed computers. For some military and space applications, they offer exceptional radiation hardness. Also discussed are: 1. the choice of device approaches, 2. manufacturing GaAs devices, 3. heterojunction devices, and 4. GaAs production

(cont. next page)

DIALOG File 15: ABI/Inform - 71-86/May, Week 2 (Copr. Data Courier Inc.1986)

lines. Graphs. Tables. Diagrams.  
 DESCRIPTORS: Semiconductors; Integrated; Circuits;  
 Technology; Advantages; Innovations; Materials  
 CLASSIFICATION CODES: 8650 (CN=Electrical & electronics  
 industries); 5400 (CN=Research & development)

83029480

**Remote Sensing: The Best View in Town/Reliable Power:  
 Approaching Perfection**

Kaplan, Gadl

IEEE Spectrum v20n9 PP: 62-65 Sep 1983 CODEN: IEESAM ISSN:  
 0018-9235 JRNL CODE: SPC  
 DOC TYPE: Journal Paper LANGUAGE: English LENGTH: 4 Pages  
 AVAILABILITY: ABI/INFORM

Through the use of remote-sensing satellites, oceans and land masses can be viewed in the infrared, visible, and microwave portions of the spectrum. Three major developments led to remote sensing as it is known today: 1. the ability to stabilize satellites mechanically in 3 axes simultaneously, 2. the ability to optically scan a scene hundreds of kilometers away and to obtain enough meaningful detail about it, and 3. the ability to derive useful information from large data amounts. Photovoltaic arrays for spacecraft are highly reliable. These solar-cell arrays have high redundancy that stems from the series and parallel connections of individual cells. Solar arrays for future modules will be light, highly modular, and easily retractable and deployable. Work has begun on the development of spaceborne gallium arsenide solar cells. These cells are more efficient than silicon cells and can maintain acceptable efficiencies at higher temperatures. Chart.

DESCRIPTORS: Space; Satellites; NASA (space); Solar energy;  
 Reliability

CLASSIFICATION CODES: 5400 (CN=Research & development); 1500  
 (CN=Energy/Environment)

83029478

**Commercialization: High Time for Profits?**

Perry, Tekla S.

IEEE Spectrum v20n9 PP: 49-55 Sep 1983 CODEN: IEESAM ISSN:  
 0018-9235 JRNL CODE: SPC  
 DOC TYPE: Journal Paper LANGUAGE: English LENGTH: 7 Pages  
 AVAILABILITY: ABI/INFORM

Potential competitors are estimating commercial space-launching revenues could total \$6 billion through 1991. Other companies hope to manufacture pharmaceuticals, alloyed metals, and gallium arsenide crystals in space. Still others plan to gather data by means of their own satellites and then sell the information for profit. Another area of potential profit is remote sensing. Comsat Corp. (Washington, DC) wants to purchase Landsats from the government providing the weather system is included and the government guarantees the purchase of weather information. The government has stated it will stop giving away information and wants to either transfer Landsat to the private sector or shut it down by 1988. If Landsat is

withdrawn, Terre-Mar Inc. (Mountain View, California) plans to commercialize remote sensing with its own system. A table of companies and their potential projects is included. Table.

DESCRIPTORS: Satellite communications; International;  
 Commercialization; Communications satellites; Space  
 CLASSIFICATION CODES: 9180 (CN=International); 5250  
 (CN=Telecommunications systems)

83022499

**Have Rocket, Will Rent**

Marth, Del

Nation's Business v71n8 PP: 32-35 Aug 1983 CODEN: NBUSAY  
 ISSN: 0028-047X JRNL CODE: NAB  
 DOC TYPE: Journal Paper LANGUAGE: English LENGTH: 4 Pages  
 AVAILABILITY: ABI/INFORM

The US as a whole is in a position to benefit from the commercialization of space. The benefits have already been recognized by the government. President Reagan has issued a directive encouraging partnership between the private sector and the government, while the National Chamber Foundation is putting together a task force of 30 executives that are interested in space-related industries. Their job is to compile a detailed, comprehensive package of recommendations on how to foster the commercial development of space. The recommendations from the task force will be translatable into a legislative program covering such issues as ensuring open and competitive markets and joint government/industry research and development. The main objective is to establish a unified industry position to encourage private commercial activity in space. The commercial areas involved include: 1. space materials processing, 2. communications, and 3. remote sensing. US corporations have been successfully solicited by foreign competitors to send payloads up on an expendable launch vehicle (ELV) launched by the European Space Agency. US firms could lose market share to foreigners, and are now trying to build their own launch facilities.

DESCRIPTORS: Space; Shuttles; Commercialization; Business;  
 Development; Policy; Task forces; Aerospace industry

CLASSIFICATION CODES: 8680 (CN=Transportation equipment  
 industry); 2430 (CN=Business-Government relations)

82029629

**The Evolution of Civilian Space Exploitation**

Logsdon, John M.

Futures (UK) v14n5 PP: 393-404 Oct 1982 CODEN: FUTUBD ISSN:  
 0016-3287 JRNL CODE: FUR  
 DOC TYPE: Journal Paper LANGUAGE: English LENGTH: 12 Pages  
 AVAILABILITY: ABI/INFORM

The nature of the uses to which humans are putting space technology is in a rapid state of flux. It becomes increasingly possible to view space as a satisfactory workplace to conduct routine and productive activities that are related to human needs. Materials processing.

(cont. next page)

## DIALOG File 15: ABI/Inform - 71-86/May, Week 2 (Copr. Data Courier Inc. 1986)

communications, and earth observation all constitute potential commercial areas for civil activities in space. However, major challenges as well as opportunities are now presented by the relationships between: 1. civilian and military uses of space, and 2. governmental and non-governmental bodies involved. Governments of industrial countries are trying to identify the proper level of public investment in space technology and the best way to obtain associated benefits. Substantial rewards apparently await the opening up of space to industrial activities, and the private sector is destined to become much less of a junior partner in the future exploitation of space. Determinants of space policy and programs in the future will be even more diverse than in the past, with commercialization assuming a much larger role. Tables.

DESCRIPTORS: Space; Exploration; NASA (space); Strategy; R&D; Investment; Technology; Public sector

CLASSIFICATION CODES: 5200 (CN=Communications & Information management); 9550 (CN=Public sector)

82028173

**Gallium Arsenide: Silicon's New Competition**

Post, Charles T.

Iron Age v225n31 PP: 51-52 Nov 1, 1982 CODEN: IRAGAN ISSN:

0164-5137 JRNL CODE: IAR

DOC TYPE: Journal Paper LANGUAGE: English LENGTH: 2 Pages

AVAILABILITY: ABI/INFORM

A new technology, still in the early stages of development, may give a big boost to optical power transmission systems and may make power generation in space more practical. Gallium arsenide devices have the potential to make direct broadcast from satellites to roof-top antennas. Researchers in microelectronics are particularly interested in gallium arsenide, which promises to improve performance in handling many of the electronic chores now performed by silicon. Gallium arsenide semiconductors could provide more efficient microelectronic devices, higher frequency communications, faster digital data processing, and longer lived solar cells for space applications. Gallium arsenide could also be a serious candidate for solid state injection lasers. Gallium arsenide is not new to the semiconductor scene. It has been used in microwave transistors and in light-emitting diodes. The problem with this material is that it has been difficult to produce at a reasonable cost. However, gallium arsenide wafers are now much easier to produce.

DESCRIPTORS: Semiconductors; Innovations; Applications; Communications; Materials

CLASSIFICATION CODES: 8650 (CN=Electrical & electronics industries)

82012247

**Out of This World-Business Probes the Promise of Space**

Scheibla, Shirley Hobbs

Barron's v62n17 PP: 8-9 Apr 26, 1982 CODEN: BRNSAD ISSN:

0005-6073 JERL CODE: BAR

DOC TYPE: Journal Paper LANGUAGE: English LENGTH: 2 Pages

## AVAILABILITY: ABI/INFORM

Many companies are already booking space on the Space Shuttle in hopes of reaping commercial benefits. One such project is that of GTI Inc. (San Diego, California), a maker of electronic devices, which is building a furnace with room for many crucibles that will be used to test various metal alloying processes. McDonnell Douglas and Johnson & Johnson will conduct experiments on the feasibility of making drugs in space. Microgravity Research Associates (Coral Gables, Florida) is planning to "grow" semiconductor crystals in space. Space Transportation of Princeton, New Jersey wants to contract with the National Aeronautics and Space Administration (NASA) to build and operate a shuttle whose space they can rent out. The Shuttle is receiving stiff competition in its satellite launching business from Europe's Arianespace and from Japan. Its fixed-price contracts have priced this service too low. Eventually, the Shuttle may be used to build manned space stations or a huge solar energy collector.

DESCRIPTORS: Commercial; Space; Shuttles; Communications satellites; NASA (space)

CLASSIFICATION CODES: 8330 (CN=Broadcasting & telecommunications)

82011325

**NASA Will Be Looking for a Payback from Its Payloads**

Welmer, George A.

Iron Age v225n9 PP: 42-43 Mar 19, 1982 CODEN: IRAGAN ISSN:

0164-5137 JRNL CODE: IAR

DOC TYPE: Journal Paper LANGUAGE: English LENGTH: 2 Pages

AVAILABILITY: ABI/INFORM

The Space Shuttle was initiated to stimulate the profitable use of space. The biggest business customer on these flights will be the communications industry due to the rapid growth of satellite business. Metallurgical and chemical experiments will also be numerous on the shuttle due to the zero gravity environment which produces alloys with different characteristics from those produced on earth. GTI Corp. plans to conduct low-gravity metallurgical research for industry, using a 200-pound cylindrical furnace that will resolidify metal alloys. Cavities within the furnace will undergo different time-temperature profiles controlled by a computer. The Japanese and German governments plan to conduct materials processing experiments in an intense way on Spacelabs, which consist of a pressurized module providing laboratory facilities and an unpressurized instrument pallet, all carried in the shuttle's cargo bay. Each request for shuttle space is examined for propriety, scientific aim, and safety.

DESCRIPTORS: NASA (space); Space; Shuttles; Commercial; Markets

CLASSIFICATION CODES: 9550 (CN=Public sector); 5400 (CN=Research & development)

## DIALOG File 15: ABI/Inform - 71-86/May, Week 2 (Copr. Data Courier Inc. 1986)

82003742

**Count-Up for Space Insurance**

Banham, Russ

Jrnl of Insurance v43 PP: 26-30 Jan/Feb 1982 ISSN: 0022-1929

JRNL CODE: III

DOC TYPE: Journal Paper LANGUAGE: English LENGTH: 4 Pages

AVAILABILITY: ABI/INFORM

Recent successes by the space shuttle Columbia have hastened the day when space enterprises will be possible. Many industries will benefit from the use of space as the communications industry already has. Given the fact that some industries are actively planning to manufacture in space, the pharmaceutical industry in particular, the insurance industry will soon be challenged to provide the proper coverages in such areas as manufacturing facilities, liability, and bodily injury exposures. Exposures will be high as illustrated by the fact that the US government has already insured the space shuttle for about \$100 million. The ultimate role of the shuttle is to act as a "space truck" used for the assembly of space platforms and other jobs. Space travel, which is expected to be common at some future period, poses yet another challenge to the insurance industry. Both insurance and reinsurance will be needed in new areas, and it is probable that international consortiums will have to be formed. As routine access to space becomes commonplace, previous concepts of risks, hazards, and perils will have to be re-evaluated.

DESCRIPTORS: Space; Vehicles; Satellites; Insurance coverage; Property Insurance; Liability Insurance

CLASSIFICATION CODES: 8680 (CN=Transportation equipment industry); 8650 (CN=Electrical & electronics industries); 8220 (CN=Property & casualty insurance)

81024415

**Implications of the Shuttle: Our Business in Space/Spacelab: Whence, and Whither**

Grey, Jerry; Owen, Kenneth

Technology Review v84n1 PP: 34-46 Oct 1981 CODEN: TEREAU

ISSN: 0040-1692 JRNL CODE: TCR

DOC TYPE: Journal Paper LANGUAGE: English LENGTH: 11 Pages

AVAILABILITY: ABI/INFORM

The technology to build reusable, reliable, and economical vehicles to launch payloads into space is now available. The US National Aeronautics and Space Administration (NASA) has developed a reusable shuttle with many new capabilities. Europe's contribution to space-shuttle development is Spacelab, a manned laboratory that will fit into the orbiter's cargo bay and make extended observations on selected scientific flights. The most exciting aspect of space industrialization involves the application of space environment to industrial processes. The precursors to these enterprises are already growing rapidly. A broad segment of private industry has become familiar with the prospects for industry in space. Some of the industries include: 1. pharmaceuticals, 2. electronic devices, 3. glass products, and 4. advanced alloys. Commercial success is promising, but can only be accomplished through imaginative partnerships between

public and private enterprise. References.

DESCRIPTORS: Space; Vehicles; Shuttles; ESRO; NASA (space); Joint ventures; Aerospace Industry; Projects

CLASSIFICATION CODES: 8680 (CN=Transportation equipment industry)

81024411

**Europe's Launch into Space Business**

Cowen, Robert

Technology Review v84n1 PP: 6,14 Oct 1981 CODEN: TEREAU

ISSN: 0040-1692 JRNL CODE: TCR

DOC TYPE: Journal Paper LANGUAGE: English LENGTH: 2 Pages

AVAILABILITY: ABI/INFORM

As commercial opportunities in space improve, the competition will not be left to the superpowers. Europe has announced the development of Arianespace, the first commercial operational space carrier. Initial problems were corrected in earlier tests. If the fourth and final test flight is successful, Ariane will be the first of what may be a family of increasingly powerful launchers to challenge the US and the USSR for the expanding business of lofting other countries' satellites into space. An enormous demand is expected for launch vehicles for communications satellites, as well as miscellaneous earth-observing, materials-processing, and scientific satellites. The relatively low cost of launching such satellites with the space shuttle has created a demand beyond the shuttle's capacity. Ariane offers an alternative until the shuttle, which is not operational, completes its flight tests. Arianespace, a private company with shareholders that include 36 companies and 11 banks in various European Space Agency (ESA) member countries, is likely to pick up some of the expendable launcher business.

DESCRIPTORS: Europe; ESRO; Projects; Space; Vehicles; Shuttles

CLASSIFICATION CODES: 8680 (CN=Transportation equipment industry)

80004556

**Space Shuttle Lab Could Help Launch New Drugs**

Anonymous

Chemical Week v126n7 PP: 40-41 Feb 13, 1980 CODEN: CHWKA9

ISSN: 0009-272X JRNL CODE: CEM

DOC TYPE: Journal Paper LANGUAGE: English

AVAILABILITY: ABI/INFORM

Some of science's most promising new drugs have lacked low-cost ways to produce them. However, in 1982, the National Aeronautics and Space Administration (NASA) and McDonnell Douglas Corp. will begin joint testing of a drug purification system aboard the space shuttle. The technique is known as electrophoresis, and in the weightless environment of space it could increase yields of certain drugs by 400 times the yields possible on earth. Drugs being considered for such production are antihemophilic B, beta pancreatic cells, and urokinase. The

(cont. next page)

## DIALOG File 15: ABI/Inform - 71-86/May, Week 2 (Copr. Data Courier Inc. 1986)

constraints presented in a gravity environment are absent in electrophoresis, and industrial chemicals appear to be other potential products of the space-shuttle project. If the tests in space prove to be successful, it is likely that partnership arrangements will be made with a number of pharmaceutical companies. McDonnell Douglas scientists have come up with a continuous flow system that maintains a steady stream of materials in the electrophoresis unit, and the process employed to purify drugs depends on the electrical field in a solution.

DESCRIPTORS: New; Drugs; Space; Vehicles; NASA (space); McDonnell Douglas-St Louis; Research

CLASSIFICATION CODES: 8641 (CN=Pharmaceuticals Industry); 8680 (CN=Transportation equipment Industry)

79001592

## Space Law for Business Planners

Dula, Arthur M.

Jrnl of Contemporary Business v7n3 PP: 113-126 1978 CODEN: JCBUDD ISSN: 0042-0298 JRNL CODE: JCB

DOC TYPE: Journal Paper LANGUAGE: English

AVAILABILITY: ABI/INFORM

Space law is a combination of international and national law that provides a guide for control of business activity in space. Since 1958 the space powers have changed international legal concepts to create customary aerospace law. Multinational treaties originating in the United Nations crystallize this international law which affects the manner in which the U.S. conducts business in space. From the beginning of space exploration, the Soviet Union has expressed the view that profit-making private companies should not be allowed to operate in space. The U.S. reacted by creating the Communications Satellite Corporation which was an economic and technical success. The National Aeronautics and Space Administration (NASA) was drafted not for American profit but as a vehicle for international prestige. Nevertheless, a small portion of NASA's rules and regulations relate to business. Other federal statutes, rules, and regulations relating to federal contracts will directly affect business done with NASA and must, therefore, be considered as part of U.S. space law. NASA regulations disclaim liability for any damage to private business payloads, even if caused by them. Users of the shuttle are subject to the court system and the common tort law of the U.S. References.

DESCRIPTORS: Space; Law; International; Private enterprise; NASA (space); Liability; Users; UN; Treaties; Business; Planning

CLASSIFICATION CODES: 4300 (CN=Law); 1100 (CN=Economics)

78018877

## Heat Treating in a Flash

Williams, Vearl A.

Production v82n5 PP: 56-62 Nov. 1978 CODEN: PDTNAG ISSN: 0032-9819 JRNL CODE: PRD

DOC TYPE: Journal Paper LANGUAGE: English

## AVAILABILITY: ABI/INFORM

Laser beam heat treatment, using a concentrated beam of energy, selectively hardens parts nearly instantly and guarantees improved scuff resistance and longer service life. The electron beam (EB) system allows hardening of large thin parts, parts with thin cross-sections and in most cases, conventional post-straightening and grinding operations are no longer required. The heat treating is accomplished by focusing an energy beam on a metal surface. In seconds, the beam heats the localized area to its transformation temperature. Advantages of laser and EB hardening include: 1. economical selective hardening, 2. minimal or no distortion, 3. noncontamination, 4. in-line process capability, 5. self-quenching, 6. energy conservation, 7. minimization or elimination of post-hardening clean-up, 8. simple parts handling and tooling, 9. use of lower cost materials, and 10. a minimum amount of floor space is required. EB heating is an accurate, predictable process but the material's physical properties affect its heat treat characteristics. Maintenance relating to conventional heat treating is virtually eliminated. Illustrations.

DESCRIPTORS: Industrial; Technology; Lasers; Manufacturing; Heat treating (PROD); Metalworking industry; Many companies

CLASSIFICATION CODES: 8650 (CN=Electrical & electronics industries); 5300 (CN=Production management); 8660 (CN=Metalworking industry)

78016858

## Made in Space: Launching Industry Into Orbit

Clutterbuck, David

International Mgmt (UK) v33n9 PP: 18-21 Sept. 1978 CODEN: ITMGAT ISSN: 0020-7888 JRNL CODE: IMG

DOC TYPE: Journal Paper LANGUAGE: English

AVAILABILITY: ABI/INFORM

Companies will have to act now if they expect to exploit the reality of the rapid progress towards space manufacturing. The range of products that space manufacturing would make possible or improve is practically unlimited. One major advance that makes space manufacturing possible is the re-usable space shuttle, which NASA will test launch in 1979. A variety of space experiments are set to begin in 1980, many of which could lead to the establishment of factories in space. Experiment designers include universities, research organizations, and companies from both the U.S., Western Europe, and Japan. Of the processes expected to be vastly improved with experimentation are methods of making new alloys, ultra-pure materials, supermagnets, and better crystals. Expectations are high already; for instance, it is known that drugs like eurokinase cannot be made on earth because of gravity interference. Space production of eurokinase could save an estimated 50,000 deaths from heart attacks every year in the U.S. alone.

DESCRIPTORS: Technology; Space; Vehicles; NASA (space); Shuttles; Experiments; Technological change; Manufacturing;

(cont. next page)

DIALOG File 15: ABI/Inform - 71-86/May, Week 2 (Copr. Data Courier Inc.1986)

Audits

CLASSIFICATION CODES: 8680 (CN=Transportation equipment industry); 5400 (CN=Research & development); 4100 (CN=Accounting)

77010528

THE PROMISE OF THE SPACE FACTORY

WALTZ, DONALD M.

Technology Review V79 N6 PP: 38-49 MAY 1977 CODEN: TEREAU  
ISSN: 0040-1692 JRNL CODE: TCR

DOC TYPE: Journal Paper LANGUAGE: English

AVAILABILITY: ABI/INFORM

THE NEW AND CHEAPER PRODUCTS TO BE MANUFACTURED IN SPACE WILL BE PRIMARILY THOSE THAT CAN BENEFIT FROM THE LACK OF GRAVITY. THE SINGLE CRYSTAL SILICON USED FOR INTEGRATED CIRCUITS COULD BE PRODUCED IN MUCH GREATER YIELD BECAUSE OF THE ABSENCE OF CONVECTION. LASING GLASSES COULD THEORETICALLY BE PREPARED IN SPACE BY INCREASING THE CALCIUM OXIDE CONTENT OF COMMERCIAL GLASSES CURRENTLY MARKETED. CONTAINERLESS SPACE PRODUCTION OF GLASS FIBERS COULD GREATLY INCREASE THE QUALITY OF FIBERS. SOME BIOLOGICAL ENTITIES CANNOT BE ISOLATED WITH CURRENT TECHNIQUES, BUT ACCURATE SEPARATION COULD BE ACHIEVED IN ZERO GRAVITY BECAUSE THE CELLS DIFFER IN MASS/CHARGE RATIOS. THE PROCESS DEVELOPMENT PHASE OF SPACE MANUFACTURING IN THE 1980'S WILL INVOLVE STUDIES OF MATERIALS BEHAVIOR AND MANUFACTURING EQUIPMENT AND THE DESIGN OF PILOT PLANT OPERATIONS. THE INDUSTRIAL UTILIZATION PHASE SHOULD BE IN THE 1990'S. CHARTS. REFERENCES.

DESCRIPTORS: Space; Manufacturing; Predictions; Analysis

CLASSIFICATION CODES: 8600 (CN=Manufacturing industries not elsewhere classified)



**"Page missing from available version"**

*Pages 1 thru 49*

DIALOG File 15: ABI/Inform - 71-86/May, Week 2 (Copr. Data Courier Inc.1986)

86007963

**Still A-OK: The Promise of Factories in Space**

Dumaine, Brian

Fortune v113n5 PP: 49-50 Mar 3, 1986 CODEN: FORTAP ISSN:  
0015-8259 JRNL CODE: FORDOC TYPE: Journal Paper LANGUAGE: English LENGTH: 2 Pages  
AVAILABILITY: ABI/INFORM

US companies with space manufacturing ambitions doubt that the recent shuttle disaster will alter long-term plans. In fact, \$18 billion in sky-made product sales by US industry has been predicted for the year 2000. The zero-gravity of space allows manufacturers to: 1. easily rearrange molecules to make new drug compounds, 2. make materials with defect-free crystalline structures, and 3. mix metals to form perfectly blended alloys. An \$8-billion space station, which NASA hopes to place in orbit by 1994, would greatly aid these efforts. Already, McDonnell Douglas has found that space greatly facilitates the production of erythropoietin, a drug that could help anemics. Also, Microgravity Research Associates plans to market space-manufactured gallium arsenide crystals for use in semiconductor chips. A 10-year project by Minnesota Mining & Manufacturing Co. aims to produce and test crystals that could be used in a new kind of optical computer.

DESCRIPTORS: NASA (space); Drugs; Space; Manufacturing; Experiments; Semiconductors; Predictions; R&D

CLASSIFICATION CODES: 8641 (CN=Pharmaceuticals industry); 8650 (CN=Electrical & electronics industries); 5400 (CN=Research & development)

85032447

**Business Is Starting to Get Serious About Space**

Payne, Seth; Hall, Alan; Helm, Leslie; Ellis, James E.

Business Week n2913(Industrial/Technology Edition) PP: 76,79  
Sep 23, 1985 CODEN: BUWEA3 ISSN: 0007-7135 JRNL CODE: BWEDOC TYPE: Journal Paper LANGUAGE: English LENGTH: 2 Pages  
AVAILABILITY: ABI/INFORM

The successful record of the National Aeronautics and Space Administration's (NASA) space shuttle is finally attracting paid, on-board research and development experiments by private industry. McDonnell Douglas Astronautics Co. and Ortho Pharmaceutical Corp. have an aggressive program to develop drugs in space. The shuttle has already performed 6 experiments for McDonnell Douglas, and the company has identified 6 biological products that would be profitable ventures. Other companies, including 3M Co., Rockwell, Boeing, and General Motors, are now negotiating with NASA for experiments in orbit, and industry flights on the shuttle will double or triple in 1986. This corporate commitment will help NASA to justify building a manned space station by 1994. Support is also emerging from private industry to fund 5 new university Centers for Commercial Development of Space. NASA hopes these university/business labs will prepare experiments for the shuttle that will be ready for scaling up to production when a permanent space station is built in the 1990s. Tables.

DESCRIPTORS: Space; Travel; Commercial; Applications; Drugs

R&D; NASA (space); Experiments; Manycompanies; Research centers

CLASSIFICATION CODES: 5400 (CN=Research & development); 9550 (CN=Public sector)

84028775

**Competition: Who'll Win the Race for Profits in Space?**

Kuzela, Lad

Industry Week v222n3 PP: 28-31 Aug 6, 1984 CODEN: IWEEA4  
ISSN: 0039-0895 JRNL CODE: IWDOC TYPE: Journal Paper LANGUAGE: English LENGTH: 4 Pages  
AVAILABILITY: ABI/INFORM

Some analysts think the US could lose the head start in the commercial exploitation of space it gained with the Space Shuttle. Short-term financial pressures coupled with extended payoff periods could cause the US to abdicate its leading role to the Europeans and Japanese. While agreeing to participate in US efforts, both Europe and Japan have a goal of independent space-related activities. Even if optimistic projections are not fully met, space industries could be among the fastest-growing activities in the next century. Despite the lack of a firm, long-term US government financial commitment, some 350 US companies have invested in space research and 20 are negotiating with the National Aeronautics & Space Administration on such ventures as: 1. metal formation, 2. electroplating, 3. catalysts, 4. glass alloys, and 5. long-term blood storage. The first space venture to reach commercial production, perhaps by 1987, may be a government-industry effort in electrophoresis. Besides economic issues, political, social, and legal questions could pose problems.

DESCRIPTORS: Earth stations (TC); Communications satellites International; Economic policy

CLASSIFICATION CODES: 1120 (CN=Economic policy & planning); 5250 (CN=Telecommunications systems); 9180 (CN=International)

84027623

**Pharmacy Poised to Enter Age of Made-in-Space Drugs**

White, John P.

Drug Topics v128n15 PP: 94,96 Aug 6, 1984 CODEN: DGTNA7  
ISSN: 0012-6616 JRNL CODE: RXTDOC TYPE: Journal Paper LANGUAGE: English LENGTH: 2 Pages  
AVAILABILITY: Medical Economics Co., Box 553, Oradell, NJ

07649

Within the near future, new pharmacologic agents to aid in the treatment of such conditions as diabetes and hemophilia are expected to be produced by pharmaceutical manufacturing operations located in outer space. The shuttle launch scheduled for August 24 will carry McDonnell Douglas Corp. engineer Charles D. Walker, who will begin the Electrophoresis Operations in Space (EOS) project. Using continuous flow electrophoresis, Walker will separate a hormone from a protein solution without the severely limiting effects of gravity on

(cont. next page)

ORIGINAL PAGE IS  
OF POOR QUALITY

DIALOG File 15: ABI/Inform - 71-88/May, Week 2 (Copr. Data Courier Inc.1988)

sample yield and purity. After the shuttle returns to earth, Ortho Pharmaceutical Corp., a partner of McDonnell Douglas in the venture, will conduct the animal and human testing of the material manufactured in space. Ortho hopes the product will be ready to distribute commercially by 1987. A much larger, fully automated electrophoresis unit with greatly increased production capacity is planned for a 1985 shuttle flight. By 1988, a full-scale manufacturing plant is expected to be placed in orbit. Diagram.

DESCRIPTORS: Pharmaceutical industry; Experiments; Joint ventures; Research

CLASSIFICATION CODES: 8641 (CN=Pharmaceuticals industry); 5400 (CN=Research & development)

84011364

**Space Commercialization: How Soon the Payoffs?**

Logsdon, John M.

Futures (UK) v16n1 PP: 71-78 Feb 1984 CODEN: FUTUBD ISSN: 0016-3287 JRNL CODE: FUR

DOC TYPE: Journal Paper LANGUAGE: English LENGTH: 8 Pages AVAILABILITY: ABI/INFORM

Space advocates have increasingly promoted the commercial potential of space activities to justify public expenditures for space programs. Satellite communications will continue to be a viable space enterprise; however, transportation services for satellite launching have limited commercial prospects. The commercial viability of on-orbit services will be dependent upon the development of a large-scale space industry based on materials processing and space manufacturing. While space manufacturing may yield potentially high payoffs to the private sector, these will not be realized in the short term. A substantial amount of research into real space business opportunities must be conducted before sizable private investments are made in space manufacturing. In addition, space manufacturing will require the development of an extensive orbital infrastructure which will take years to complete. Space advocates should stress the scientific and exploration benefits of the space program rather than its remote economic payoffs. References.

DESCRIPTORS: Space; Commercialization; NASA (space); R&D; Telecommunications; Transportation; Predictions

CLASSIFICATION CODES: 5400 (CN=Research & development); 1110 (CN=Economic conditions & forecasts)

83029478

**Commercialization: High Time for Profits?**

Perry, Tekla S.

IEEE Spectrum v20n9 PP: 49-55 Sep 1983 CODEN: IEESAM ISSN: 0018-9235 JRNL CODE: SPC

DOC TYPE: Journal Paper LANGUAGE: English LENGTH: 7 Pages AVAILABILITY: ABI/INFORM

Potential competitors are estimating commercial space-launching revenues could total \$6 billion through 1991. Other companies hope to manufacture pharmaceuticals, alloyed metals, and gallium arsenide crystals in space. Still others

plan to gather data by means of their own satellites and then sell the information for profit. Another area of potential profit is remote sensing. Comsat Corp. (Washington, DC) wants to purchase Landsats from the government providing the weather system is included and the government guarantees the purchase of weather information. The government has stated it will stop giving away information and wants to either transfer Landsat to the private sector or shut it down by 1988. If Landsat is withdrawn, Terre-Mar Inc. (Mountain View, California) plans to commercialize remote sensing with its own system. A table of companies and their potential projects is included. Table.

DESCRIPTORS: Satellite communications; International; Commercialization; Communications satellites; Space

CLASSIFICATION CODES: 9180 (CN=International); 5250 (CN=Telecommunications systems)

78016858

**Made in Space: Launching Industry Into Orbit**

Clutterbuck, David

International Mgmt (UK) v33n9 PP: 18-21 Sept. 1978 CODEN: ITMGAT ISSN: 0020-7888 JRNL CODE: IMG

DOC TYPE: Journal Paper LANGUAGE: English AVAILABILITY: ABI/INFORM

Companies will have to act now if they expect to exploit the reality of the rapid progress towards space manufacturing. The range of products that space manufacturing would make possible or improve is practically unlimited. One major advance that makes space manufacturing possible is the re-usable space shuttle, which NASA will test launch in 1979. A variety of space experiments are set to begin in 1980, many of which could lead to the establishment of factories in space. Experiment designers include universities, research organizations, and companies from both the U.S., Western Europe, and Japan. Of the processes expected to be vastly improved with experimentation are methods of making new alloys, ultra-pure materials, supermagnets, and better crystals. Expectations are high already; for instance, it is known that drugs like eurokinase cannot be made on earth because of gravity interference. Space production of eurokinase could save an estimated 50,000 deaths from heart attacks every year in the U.S. alone.

DESCRIPTORS: Technology; Space; Vehicles; NASA (space); Shuttles; Experiments; Technological change; Manufacturing; Audits

CLASSIFICATION CODES: 8680 (CN=Transportation equipment industry); 5400 (CN=Research & development); 4100 (CN=Accounting)

**BIOSIS PREVIEWS DATABASE**

Permission for the reproduction of bibliographic information from the BIOSIS PREVIEWS database is granted by BioSciences Information Service, copyright 1986.

## DIALOG File 285: BIOBUSINESS - 1986/MAY (Copr. BIOSIS)

0042000

## CODON (BRISBANE, CA) PRODUCT PURIFICATION ON SPACE SHUTTLE.

ANON

APPLIED GENETICS NEWS, VOL.6, NO.5, P.6. 1 PAGE, 1985.

Language: ENGLISH

Codon has developed a method to produce large quantities of erythropoietin that uses genetic engineering techniques. McDonnell Douglas, who contracted the development, is using its Electrophoresis Operation in Space (EOS) device to purify the product aboard the space shuttle launched on November 25, 1985. The EOS device is capable of separating 700 times the material that a similar device on Earth could separate. It can also purify the materials four times greater. Codon anticipates manufacturing the erythropoietin for clinical markets.

Descriptors: GENETIC ENGINEERING; GENETICS; NEW TECHNIQUE; RESEARCH AND DEVELOPMENT; SCIENTIFIC RESEARCH

Subject Codes/Headings: 04600 - PROTEINS &amp; RELATED

COMPOUNDS; 51100 - GENETICS-GENERAL; 72100 - METHODS, MATERIALS &amp; APPARATUS

Company Name: CODON, BRISBANE, CA

0038465

## PHARMACEUTICAL INDUSTRY EXPLORES COMMERCIAL POTENTIAL OF SPACE RESEARCH.

ORR T

GENETIC ENGINEERING NEWS, VOL.5, NO.10, P.5,11, 1985.

Language: ENGLISH

Descriptors: DRUG MANUFACTURING; PURIFICATION

Subject Codes/Headings: 21100 - PHARMACOLOGY &amp; CHEMOTHERAPY

0035986

## HAYASHIBARA TO ENGAGE IN SHUTTLE LAB EXPERIMENT.

ANON

JAPAN ECONOMIC JOURNAL, VOL.23, NO.1161, P.16, 1985.

Language: ENGLISH

Hayashibara Biochemical Laboratories Inc. (HBL) will engage in experiments for mass separation and purification of physiological activating substances such as interferon. The electrophoresis operation in space (EOS) module on board an American space shuttle will be used for the experiments. Hayashibara will be the first Japanese user of the EOS system, which was developed by McDonnell Douglas Corp.

Descriptors: BIOTECHNOLOGY; CHEMICAL INDUSTRY; CHEMICALS; JAPAN; RESEARCH; RESEARCH AND DEVELOPMENT; SCIENTIFIC RESEARCH; SPACE EXPLORATION; TECHNIQUE; TECHNOLOGY

Subject Codes/Headings: 15900 - IMMUNE SYSTEM; 21100 - PHARMACOLOGY & CHEMOTHERAPY; 72100 - METHODS, MATERIALS & APPARATUS; 80200 - AEROSPACE & UNDERWATER BIOLOGY

Company Name: HAYASHIBARA BIOCHEMICAL LABORATORIES INC., JAPAN

0034109

## MCDONNELL-DOUGLAS SEEKS NEW PARTNER FOR SPACE SHUTTLE PRODUCT.

HESTER A S

PO BOX 1304, FORT LEE, N.J. 07024, USA.

GENETIC TECHNOLOGY NEWS, VOL.5, NO.10, P.9, 1985.

Language: ENGLISH

Descriptors: ZERO GRAVITY ELECTROPHORESIS; PROTEIN PURIFICATION

Subject Codes/Headings: 04600 - PROTEINS & RELATED COMPOUNDS; 72100 - METHODS, MATERIALS & APPARATUS

0032201

## PURIFIED CELL PRODUCTS PRODUCED IN SPACE.

ANON

AGRICULTURAL BIOTECHNOLOGY NEWS, VOL.2, NO.2, P.12, 1985.

Language: ENGLISH

Descriptors: PROTEIN; ENZYME; HORMONE; BIOLOGICS; ELECTROPHORESIS-OPERATIONS-IN-SPACE; ENDOTRONICS INC; AUTOMATED CULTURE SYSTEM; PRODUCT DEVELOPMENT; BIOTECHNOLOGY INDUSTRY; PHARMACEUTICAL INDUSTRY

Subject Codes/Headings: 04100 - BIOCHEMISTRY & CHEMISTRY-GENERAL; 04600 - PROTEINS & RELATED COMPOUNDS; 04625 - ENZYMES; 15800 - ENDOCRINE SYSTEM; 21100 - PHARMACOLOGY & CHEMOTHERAPY; 72100 - METHODS, MATERIALS & APPARATUS; 72300 - TISSUE CULTURE; 80200 - AEROSPACE & UNDERWATER BIOLOGY; 80300 - BIOENGINEERING

0032123

## SPACE SHUTTLE DRUG TESTED.

AM PHARM ASSOC

AMERICAN PHARMACY, VOL.25, NO.9, P.20, 1985.

Language: ENGLISH

Descriptors: PRODUCT DEVELOPMENT; PHARMACEUTICAL INDUSTRY; ORTHO PHARMACEUTICAL CORPORATION; ELECTROPHORESIS

Subject Codes/Headings: 21100 - PHARMACOLOGY & CHEMOTHERAPY; 72100 - METHODS, MATERIALS & APPARATUS; 80200 - AEROSPACE & UNDERWATER BIOLOGY

0031502

## SPACE BIOPROCESSING.

TODD P

UNIV. CITY SCI. CENTER, 3401 MARKET ST., SUITE 220, PHILADELPHIA, PA. 19104.

BIO-TECHNOLOGY (MARTINSVILLE), VOL.3, NO.9, P.786-790, 1985.

Language: ENGLISH

Descriptors: ELECTROPHORESIS; ISOELECTRIC FOCUSING; BIOTECHNOLOGY

Subject Codes/Headings: 80300 - BIOENGINEERING

ORIGINAL PAGE IS  
OF POOR QUALITY

## DIALOG File 285: BIOBUSINESS - 1986/MAY (Copr. BIOSIS)

0030199

## NASA'S SPACE FACTORY.

ANON

CHEMICAL MARKETING REPORTER, VOL.228, NO.9, P.3,15, 1985.

Language: ENGLISH

Space Industries of Houston, Texas, and the National Aeronautics and Space Administration (NASA) have signed an agreement to launch into orbit via space shuttle a drug and chemical factory in 1989. The agreement also calls for the cooperation of Space Industries and NASA during the definition and initial design phase of the new space station which is estimated to cost between 250 and 500 million dollars. The factory will represent the first effort by a private company and NASA to share information for a commercial space bound operation. Once launched, the facility would maintain an orbital altitude of 256 miles, where pharmaceuticals, chemicals and exotic metals and alloys will be produced to take advantage of zero gravity conditions. A photograph shows a model of the Space Industries orbital factory.

Descriptors: AGREEMENTS; CHEMICALS; CONTRACTS; CORPORATIONS; FACILITY PLANNING; FACTORIES; FEDERAL GOVERNMENT; GOVERNMENT; GOVERNMENT AGENCY; INDUSTRIAL ENGINEERING; INDUSTRIAL PLANTS; METALS; NASA; OUTER SPACE; PHARMACEUTICALS; PRIVATE COMPANIES; PRIVATE SECTOR; SPACE PLANNING; SPACE SHUTTLE

Subject Codes/Headings: 21100 - PHARMACOLOGY & CHEMOTHERAPY; 72100 - METHODS, MATERIALS & APPARATUS

Company Name: SPACE INDUSTRIES, HOUSTON, TX

029341

## PROTEIN CRYSTAL GROWTH IN SPACE.

BUGG C E

INST. DENT. RES., UNIV. ALA., BIRMINGHAM, ALA., USA.

PHARMACEUTICAL TECHNOLOGY, VOL.9, NO.8, P.39, 1985.

Pharm Tech Conference, Cherry Hill, N.J., USA, Sept. 10-12,

1985. PHARM TECHNOL

Language: ENGLISH

Subject Codes/Headings: 04600 - PROTEINS & RELATED COMPOUNDS; 72100 - METHODS, MATERIALS & APPARATUS

029338

## RESEARCH IN PHARMACEUTICAL TECHNOLOGY AS A COMPONENT OF THE USA MICROGRAVITY SCIENCES AND APPLICATIONS PROGRAM.

TODD P; SLOYER J L

PHILA. BIOPROCESSING PHARMACEUTICAL RES. CENT.

PHARMACEUTICAL TECHNOLOGY, VOL.9, NO.8, P.38, 1985.

Pharm Tech Conference, Cherry Hill, N.J., USA, Sept. 10-12,

1985. PHARM TECHNOL

Language: ENGLISH

Descriptors: NATIONAL AERONAUTICS AND SPACE ADMINISTRATION USA

Subject Codes/Headings: 21100 - PHARMACOLOGY & CHEMOTHERAPY

001477

## CENTERS FOR SPACE BIOTECHNOLOGY.

MILLER J A

SCIENCE NEWS, VOL.126, NO.18, P.280, 1984.

Language: ENGLISH

The National Aeronautics and Space Administration grants \$450,000 per year for three years to the University of Arizona and to the University City Science Center of Philadelphia. The money is to fund biological research of a space environment of near-weightlessness. Organic separations, bioprocessing, and pharmaceutical analysis are the main topics of the scientific research.

Descriptors: ANALYSIS; BIOTECHNOLOGY; MONEY; NASA; SCIENTIFIC RESEARCH

Subject Codes/Headings: 72100 - METHODS, MATERIALS & APPARATUS; 80200 - AEROSPACE & UNDERWATER BIOLOGY

001296

## INDUSTRY'S FIRST ASTRONAUT - THE FIRST FULLY AUTOMATED SPACE FACTORY TAKES SHAPE.

KUZELA L

INDUSTRY WEEK, VOL.221, NO.7, P.15-16, 1984.

Language: ENGLISH

Charles Walker is discussed as the first industry representative astronaut. Walker is employed by the McDonnell Douglas Corporation and was sent up in the space shuttle to test his patented electrophoresis process for the purification of biological substances. McDonnell Douglas plans to build large-scale electrophoresis factories in space. Space production increases yields by more than 700 times earth production because gravity does not interfere with separations.

Descriptors: BIOLOGICALS; MANUFACTURING; OUTER SPACE; RESEARCH; SCIENTIFIC RESEARCH; SPACE SHUTTLE; TECHNOLOGY; TESTING

Subject Codes/Headings: 72100 - METHODS, MATERIALS & APPARATUS; 80200 - AEROSPACE & UNDERWATER BIOLOGY

Named Person: WALKER, CHARLES, SCIENTIST, MCDONNELL DOUGLAS CORP., ACHIEVEMENTS AND AWARDS

001132

## THE \$30 BILLION POTENTIAL FOR MAKING CHEMICALS IN SPACE.

ANON

CHEMICAL WEEK, VOL.135, NO.16, P.44-46,51+, 1984.

Language: ENGLISH

The potential for chemical manufacturing in space and the plans of a number of companies to perform experiments and limited manufacturing aboard the space shuttle are discussed. The effects and advantages of zero-gravity conditions on some chemical reactions and physical transformations are explained. It is estimated that manufacturing in space could generate sales of \$42 billion by the year 2000. Plans of specific companies are described, and a table lists the fields of

(cont. next page)

ORIGINAL PAGE IS  
OF POOR QUALITY

**DIALOG File 285: BIOBUSINESS - 1986/MAY (Copr. BIOSIS)**

Interest of companies which have approached NASA about conducting research aboard the space shuttle. Genetic engineering, monoclonal antibodies, semiconductor materials, and collagen fibers are noted as areas of particular interest for space development. Photographs of industry personnel and space equipment are included.

Descriptors: BIOTECHNOLOGY; CHEMICAL INDUSTRY; ELECTRONIC INDUSTRY; GENETICS; MANUFACTURING; NASA; PHARMACEUTICAL INDUSTRY; RESEARCH AND DEVELOPMENT; SPACE SHUTTLE; TECHNOLOGICAL CHANGE; TECHNOLOGY

Subject Codes/Headings: 51100 - GENETICS-GENERAL

## DIALOG File 285: BIOBUSINESS - 1986/MAY (Copr. BIOSIS)

0042000

## CODON (BRISBANE, CA) PRODUCT PURIFICATION ON SPACE SHUTTLE.

ANON

APPLIED GENETICS NEWS, VOL.6, NO.5, P.6. 1 PAGE, 1985.

Language: ENGLISH

Codon has developed a method to produce large quantities of erythropoietin that uses genetic engineering techniques. McDonnell Douglas, who contracted the development, is using its Electrophoresis Operation in Space (EOS) device to purify the product aboard the space shuttle launched on November 25, 1985. The EOS device is capable of separating 700 times the material that a similar device on Earth could separate. It can also purify the materials four times greater. Codon anticipates manufacturing the erythropoietin for clinical markets.

Descriptors: GENETIC ENGINEERING; GENETICS; NEW TECHNIQUE; RESEARCH AND DEVELOPMENT; SCIENTIFIC RESEARCH

Subject Codes/Headings: 04600 - PROTEINS & RELATED COMPOUNDS; 51100 - GENETICS-GENERAL; 72100 - METHODS, MATERIALS & APPARATUS

Company Name: CODON, BRISBANE, CA

0038465

## PHARMACEUTICAL INDUSTRY EXPLORES COMMERCIAL POTENTIAL OF SPACE RESEARCH.

ORR T

GENETIC ENGINEERING NEWS, VOL.5, NO.10, P.5,11, 1985.

Language: ENGLISH

Descriptors: DRUG MANUFACTURING; PURIFICATION

Subject Codes/Headings: 21100 - PHARMACOLOGY &amp; CHEMOTHERAPY

009703

## BIOPROCESSING IN SPACE: HUMAN CELLS ATTACH TO BEADS IN MICROGRAVITY.

TSCHOPP A; COGOLI A; LEWIS M L; MORRISON D R

LABORATORIUM FOR BIOCHEMIE, E.T.H.-ZENTRUM, CH-8092 ZURICH, SWITZERLAND.

JOURNAL OF BIOTECHNOLOGY, VOL.1, NO.5-6, P.287-294, 1984.

Language: ENGLISH

Attachment to a substrate and survival of human embryonic kidney (HEK) cells was tested in an incubator installed in the flight-deck of the Space Shuttle Challenger during its eighth mission. HEK cells are producing the enzyme urokinase and are presently investigated as candidates for electrophoretic separation in an apparatus developed and manufactured by McDonnell Douglas. Attachment of HEK cells to a substrate is mandatory for survival and production of urokinase after electrophoretic separation. Analysis of the samples shows that cells adhere, spread and survive in microgravity (< 10<sup>-3</sup> times. g) conditions and the ground controls at 1 times. g. This result represents an important step towards further bioprocessing in space.

Descriptors: SPACE SHUTTLE CHALLENGER; UROKINASE

PRODUCTION: BIOTECHNOLOGY

Subject Codes/Headings: 04625 - ENZYMES; 21100 - PHARMACOL-

OGY & CHEMOTHERAPY; 72100 - METHODS, MATERIALS & APPARATUS;  
72300 - TISSUE CULTURE; 80200 - AEROSPACE & UNDERWATER  
BIOLOGY; 80300 - BIOENGINEERING



ORIGINAL PAGE IS  
OF POOR QUALITY

**GPO DATABASE**

Citations derived from the GPO database were retrieved through the DIALOG system and reprinted through the permission of Dialog Information Services, Inc.

## DIALOG File 66: GPO MONTHLY CATALOG - JUL 1976 TO MAY 1986

LCCN: gp 85019592  
Place of Publication: Virginia GPO Item No.: 830-H-14 (microfiche)  
Stock No.: N84-32202; NASA  
Technical Report No.: RAI-84-B-4  
Languages: English  
Document Type: Monograph  
"Period covered: 5/17/84 - 6/16/84." "7/3/84." Bibliography:  
p. 7-1. Microfiche.~ [Washington, D.C.? :- National Aeronautics and Space Administration,~ 1984?].~ 1 microfiche ; 11 x 15 cm.  
Descriptors: Crystals-Growth-Mathematical models

0233248 NAS 1.26-174057  
Final report for NASA grant NAG 3-188 entitled Research on gallium arsenide diffused junction solar cells for the period October 1, 1982 to June 30, 1984. J.M. Borrego, S.K. Ghandhi  
Borrego, Jose M.  
Ghandhi, Sorab Khushro., 1928-  
Corporate Source: Rensselaer Polytechnic Institute. Electrical, Computer, and Systems Engineering Dept. United States. National Aeronautics and Space Administration.  
Series: NASA-CR ; 174057; NASA contractor report ; 174057. [Washington, D.C.? : National Aeronautics and Space Administration, 1984] 1 v. : ill. ; 28 cm.  
Publication Date(s): 1984  
LCCN: gp 85018222  
Place of Publication: District of Columbia GPO Item No.: 830-H-14 (microfiche)  
Technical Report No.: N 85-11457  
Languages: English  
Document Type: Monograph  
"Rensselaer Polytechnic Institute." "October 1984." "N85-11457"--Microfiche header. Microfiche.~ [Washington, D.C.? :- National Aeronautics and Space Administration,~ 1985].~ 1 microfiche ; 11 x 15 cm.  
Descriptors: Gallium compounds; Solar batteries

0233241 NAS 1.26-173940  
Investigation of test methods, material properties, and processes for solar cell encapsulants twenty-sixth quarterly progress report /. for Jet Propulsion Laboratory ; by P.B. Willis, B. Baum ; by Springborn Laboratories, Inc  
Willis, P. B.  
Baum, B.  
Corporate Source: Jet Propulsion Laboratory (U.S.) Springborn Laboratories.  
Series: NASA-CR ; 173940; NASA contractor report ; 173940. Pasadena, Calif. : The Laboratory, [1983] 1 v. : ill. ; 28 cm.  
Publication Date(s): 1983  
LCCN: gp 85018215  
Place of Publication: California GPO Item No.: 830-H-14 (microfiche)  
Technical Report No.: N 84-34029; DOE/JPL-954527-26

Languages: English  
Document Type: Monograph  
"November 1983." "N84-34029"--Microfiche header.  
"DOE/JPL-954527-26." "JPL contract 954527, project 6072.1." Microfiche.~ [Washington, D.C.? :- National Aeronautics and Space Administration,~ 1984].~ 1 microfiche ; 11 x 15 cm.  
Descriptors: Solar cells-Testing

0228363 NAS 1.26-173749  
Crystal growth of device quality GaAs in space annual report /. to National Aeronautics and Space Administration ; submitted by Harry C. Gatos and Jacek Lagowski  
Gatos, Harry C.  
Lagowski, J.  
Corporate Source: United States. National Aeronautics and Space Administration. Massachusetts Institute of Technology. Dept. of Materials Science and Engineering.  
Series: NASA-CR ; 173749; NASA contractor report ; 173749. Washington, D.C. : The Administration, [1984] 1 v. : ill. ; 28 cm.  
Publication Date(s): 1984  
LCCN: gp 85013337  
Place of Publication: District of Columbia GPO Item No.: 830-H-14 (microfiche)  
Technical Report No.: N 84-28613  
Languages: English  
Document Type: Monograph  
"Department of Materials Science and Engineering, Massachusetts Institute of Technology." "July 1984." Includes bibliographical references. Microfiche.~ [Washington, D.C.? - National Aeronautics and Space Administration,~ 1984].~ 2 microfiches ; 11 x 15 cm.  
Descriptors: Gallium compounds; Cosmochemistry

0228272 NAS 1.26-173517  
Materials Processing in Space Workshop minutes, October 27-28, 1982  
Corporate Source: Materials Processing in Space Workshop (1982 : Redondo Beach, Calif.)  
Corporate Source: TRW Defense and Space Systems Group. United States. National Aeronautics and Space Administration.  
Series: NASA-CR ; 173517; NASA contractor report ; 173517. Redondo Beach, Calif. : TRW, [1982] 1 v. : ill. ; 28 cm.  
Publication Date(s): 1982  
LCCN: gp 85013246  
Place of Publication: California GPO Item No.: 830-H-14 (microfiche)  
Technical Report No.: N 84-24601  
Languages: English  
Document Type: Monograph  
"Part of the Space Station Needs, Attributes and Architectural Options study that TRW is performing for NASA." "N84-24601"--Microfiche header. Microfiche.~ [Washington, (cont. next page)]

## DIALOG File 66: GPO MONTHLY CATALOG - JUL 1976 TO MAY 1986

D.C.? :- National Aeronautics and Space Administration,~  
1984].~ 1 microfiche ; 11 x 15 cm.  
Descriptors: Materials Processing in Space Workshop; (1982  
; Redondo Beach, Calif.); Space stations- Industrial  
applications

0228234 NAS 1.26-173148  
**Crystal growth of device quality GaAs in space.submitted by  
Harry C. Gatos and Jacek Lagowski**  
Gatos, Harry C.  
Lagowski, J.  
Corporate Source: United States. National Aeronautics and  
Space Administration. Massachusetts Institute of Technology.  
Dept. of Materials Science and Engineering.  
Series: NASA-CR ; 173148; NASA contractor report ; 173148.  
Washington, D.C.? : National Aeronautics and Space  
Administration, [1983] 1 v. : ill. ; 28 cm.  
Publication Date(s): 1983  
LCCN: gp 85013208  
Place of Publication: District of Columbia GPO Item No.:  
830-H-14 (microfiche)  
Technical Report No.: N 84-17013  
Languages: English  
Document Type: Monograph  
At head of title: Annual report. "Department of Materials  
Science and Engineering, Massachusetts Institute of  
Technology." "Period April 1, 1982 to March 31, 1983." "June  
1983." Includes bibliographical references. Microfiche.~  
[Washington, D.C.? :- National Aeronautics and Space  
Administration,~ 1983?].~ 1 microfiche ; 11 x 15 cm.  
Descriptors: Gallium compounds; Integrated circuits

0228198 NAS 1.26-171034  
**Analysis of electrophoresis performance final report /.  
prepared for George C. Marshall Space Flight Center ; prepared  
by Glyn O. Roberts**  
Roberts, Glyn O.  
Corporate Source: George C. Marshall Space Flight Center.  
Roberts Associates, Incorporated.  
Series: NASA-CR ; 171034; NASA contractor report ; 171034.  
MSFC, AL : The Center, [1984] 1 v. : ill. ; 28 cm.  
Publication Date(s): 1984  
LCCN: gp 85013172  
Place of Publication: Alabama GPO Item No.: 830-H-14  
(microfiche)  
Technical Report No.: N 84-24716; RAI-84-E-3  
Languages: English  
Document Type: Monograph  
"Period covered: 1/27/83-4/6/84." "Roberts Associates,  
Incorporated." "Date: 4/6/84." "Contract: NAS8-35912."  
"N84-24716"--Microfiche header. "RAI-84-E-3." Microfiche.~  
[Washington, D.C.? :- National Aeronautics and Space  
Administration,~ 1984].~ 1 microfiche ; 11 x 15 cm.  
Descriptors: Electrophoresis-Data processing; Fluid dynamics  
(Space environment)

0206397 Y 4.Sci 2-98/42  
**Review of materials processing in space 1983 : hearings  
before the Subcommittee on Space Science and Applications of  
the Committee on Science and Technology, U.S. House of  
Representatives, Ninety-eighth Congress, first session,  
September 14, 15, 1983**  
Corporate Source: United States. Congress. House. Committee  
on Science and Technology. Subcommittee on Space Science and  
Applications.  
Washington : U.S. G.P.O., 1984. iii, 130 p. : ill. ; 24 cm.  
Publication Date(s): 1984  
LCCN: gp 84013997  
Place of Publication: District of Columbia GPO Item No.:  
1025-A-1, 1025-A-2 (microfiche)  
Technical Report No.: No. 42 (United States. Congress.  
House. Committee on Science and Technology)  
Languages: English  
Document Type: Monograph  
Geographic Location: United States  
Distributed to some depository libraries in microfiche.  
Includes bibliographical references.  
Descriptors: NASA Program for Materials Processing in Space  
Science and state-United States; Space sciences-United States

0191890 NAS 1.2-C 42  
**Chemical products and biological preparations : low gravity  
research in fluid processes**  
Variant Title: Low gravity research in fluid processes  
Corporate Source: United States. National Aeronautics and  
Space Administration.  
[Washington, D.C.?] : NASA, [1983?] 12 p. : ill. ; 28 cm.  
Publication Date(s): 1983  
LCCN: gp 83024374  
Place of Publication: District of Columbia GPO Item No.:  
830-C  
Languages: English  
Document Type: Monograph  
Descriptors: Crystals-Growth; Fluid dynamics (Space  
environment); Skylab Program; Gravitation; Crystals-Growth;  
Fluid dynamics (Space environment); Skylab Program;  
Gravitation

0183581 NAS 1.60-1811  
**Analysis of costs of gallium arsenide and silicon solar  
arrays for space power applications / Kent S. Jefferies**  
Jefferies, Kent S.  
Corporate Source: United States. National Aeronautics and  
Space Administration. Scientific and Technical Information  
Branch.  
Series: NASA technical paper ; 1811  
Washington, D.C. : National Aeronautics and Space  
Administration, Scientific and Technical Information Branch ;  
[Springfield, Va. : For sale by the National Technical  
(cont. next page)

## DIALOG File 66: GPO MONTHLY CATALOG - JUL 1976 TO MAY 1986

Information Service], 1981. 14 p. : ill. ; 28 cm.  
 Publication Date(s): 1981  
 LCCN: gp 83016049  
 Place of Publication: District of Columbia GPO Item No.:  
 830-H-15 (microfiche)  
 Languages: English  
 Document Type: Monograph  
 "March 1981"--Cover. Includes bibliographical references.-  
 STAR category 20.  
 Descriptors: Gallium; Silicon; Space vehicles- Electric  
 propulsion systems

0179476 NAS 1.60-2016  
 Approximate analysis of thermal convection in a  
 crystal-growth cell for spacelab 3 / Robert F. Dressler  
 Dressler, Robert F.  
 Corporate Source: United States. Office of Space Science and  
 Applications. United States. National Aeronautics and Space  
 Administration. Scientific and Technical Information Branch.  
 Series: NASA technical paper ; 2016  
 Washington, D.C. : National Aeronautics and Space  
 Administration, Scientific and Technical Information Branch ;  
 [Springfield, Va. : For sale by the National Technical  
 Information Service], 1982. 8 p. : ill. ; 28 cm.  
 Publication Date(s): 1982  
 LCCN: gp 83011937  
 Place of Publication: District of Columbia GPO Item No.:  
 830-H-15 (microfiche)  
 Languages: English  
 Document Type: Monograph  
 "NASA Office of Space Science and Applications." "June  
 1982"--Cover. Includes bibliographical references.  
 Descriptors: Convection (Astrophysics); Crystals-Growth

0173041 NAS 1.15-82433  
 Space processing applications rocket project : SPAR VI final  
 report / R. Chassay, Comp  
 Chassay, R.  
 Corporate Source: United States. National Aeronautics and  
 Space Administration. Scientific and Technical Information  
 Branch. George C. Marshall Space Flight Center.  
 Series: NASA technical memorandum ; 84233  
 Washington, D.C. : National Aeronautics and Space  
 Administration, Scientific and Technical Information Branch ;  
 [Springfield, Va. : For sale by the National Technical  
 Information Service], 1981. [293] p. : ill. ; 27 cm.  
 Publication Date(s): 1981  
 LCCN: gp 83005448  
 Place of Publication: District of Columbia GPO Item No.:  
 830-D (microfiche)  
 Languages: English  
 Document Type: Monograph  
 "October 1981"--Cover. Includes bibliographical references.  
 Contents Note: ch. 1. [No distinctive title] -- ch. 2. Post-  
 flight engineering report / edited by Robert C. Edwards -- ch.

3. SPAR VI experiment report containerless processing of glass  
 experiment 74-42 / by Ralph A. Happe -- ch. 4. Final  
 post-flight report on SPAR VI experiment no. 74-45, epitaxial  
 growth of single crystal films / M.D. Lind -- ch. 5.  
 Containerless processing technology experiment report, SPAR VI  
 experiment 76-20 / T.G. Wang ... [et al.] -- ch. 6. SPAR VI  
 technical report for experiment 76-22, directional  
 solidification of magnetic composites / by Ron G. Pirich and  
 David J. Larson, Jr.  
 Descriptors: Rockets (Aeronautics)-Launching

0123112 NAS 1.26-3370  
 A study of crystal growth by solution technique / R. B. Lal  
 Lal, R. B., 1935-  
 Corporate Source: United States. National Aeronautics and  
 Space Administration. Scientific and Technical Information  
 Branch. George C. Marshall Space Flight Center.  
 Series: NASA contractor report ; 3370  
 Washington, D.C. : National Aeronautics and Space  
 Administration, Scientific and Technical Information Branch ;  
 [Springfield, Va. : For sale by the National Technical  
 Information Service], 1981. ill, 30 p. : ill. ; 27 cm.  
 Publication Date(s): 1981  
 LCCN: gp 81005854  
 Place of Publication: District of Columbia GPO Item No.:  
 820-H-14 (microfiche)  
 Languages: English  
 Document Type: Monograph  
 "Prepared for Marshall Space Flight Center under Grant  
 NSG-8033." Jan. 1981. Includes bibliographical references.  
 Descriptors: Crystals-Growth

0122231 NAS 1.53-OSTA 80-1  
 Fluids investigations in space related to materials  
 processing  
 Corporate Source: United States. National Aeronautics and  
 Space Administration.  
 Series: Announcement of opportunity ; A.O. no. OSTA 80-1  
 Washington, D.C. : National Aeronautics and Space  
 Administration, 1980. 19 [i.e. 35] p. : ill. ; 28 cm.  
 Publication Date(s): 1980  
 LCCN: gp 81003795  
 Place of Publication: District of Columbia GPO Item No.:  
 830-H-5  
 Languages: English  
 Document Type: Monograph  
 Cover title. Mar. 10, 1980.  
 Descriptors: Fluid dynamics (Space environment); Materials  
 research

ORIGINAL PAGE IS  
OF POOR QUALITY

## DIALOG File 66: GPO MONTHLY CATALOG - JUL 1976 TO MAY 1986

0122206 NAS 1.21-443  
Materials processing in space : early experiments /.Robert  
J. Naumann and Harvey W. Herring  
Naumann, Robert J.  
Herring, Harvey W.  
Corporate Source: United States. National Aeronautics and  
Space Administration.  
Series: NASA SP ; 443  
Washington, D.C. : Scientific and Technical Information  
Branch, National Aeronautics and Space Administration : For  
sale by the Supt. of Docs., U.S. G.P.O., 1980. ix, 114 p. :  
ill. (some col.) ; 29 cm.  
Publication Date(s): 1980  
LCCN: gp 31003770  
Price: \$10.00  
Place of Publication: District of Columbia GPO Item No.:  
830-1  
Stock No.: 037-000-00809-1  
LC Call No.: TA410.N28 Dewey Call No.: 670  
Languages: English  
Document Type: Monograph  
Includes index.  
Descriptors: Skylab Program; Materials; Manufacturing  
processes

0033600 NAS 1.26-2768  
Float-zone processing in a weightless environment /.A. A.  
Fowle ... [et al.]  
Corporate Source: United States. National Aeronautics and  
Space Administration. United States. George C. Marshall Space  
Flight Center, Huntsville, Ala. Arthur D. Little, inc.  
Series: NASA contractor report ; NASA CR-2768; United  
States.; National Aeronautics and Space Administration. NASA  
contractor report ;  
Washington : National Aeronautics and Space Administration ;  
Springfield, Va. : for sale by the National Technical  
Information Service, 1976. ix, 73 p. : ill. ; 27 cm.  
Publication Date(s): 1976  
LCCN: gp 78009418  
Place of Publication: District of Columbia  
Languages: English  
Document Type: Monograph  
Prepared by Arthur D. Little, inc., under Contract no.  
NAS8-29877, for George C. Marshall Space Flight Center.  
Issued Nov. 1976. Includes bibliographical references  
Descriptors: Silicon crystals

ORIGINAL PAGE IS  
OF POOR QUALITY

## DIALOG File 66: GPO MONTHLY CATALOG - JUL 1976 TO MAY 1986

0650113 Y 4.J 89/1-99/16

Patents in space : hearing before the Subcommittee on Courts, Civil Liberties, and the Administration of Justice of the Committee on the Judiciary, House of Representatives, Ninety-ninth Congress, first session ... June 13, 1985

Corporate Source: United States. Congress. House. Committee on the Judiciary. Subcommittee on Courts, Civil Liberties, and the Administration of Justice.

Washington : U.S. G.P.O., 1985. v, 423 p. : ill. ; 24 cm.

Publication Date(s): 1985

LCCN: gp 86005715

Place of Publication: District of Columbia GPO Item No.: 1020-A, 1020-B (microfiche)

Technical Report No.: Serial no. 16 (United States. Congress. House. Committee on the Judiciary)

Languages: English

Document Type: Monograph

Geographic Location: United States

Distributed to some depository libraries in microfiche.

Shipping list no.: 85-1089-P. Includes bibliographies.

Descriptors: Patents-United States; Inventions-United States ; Space Industrialization-United States

0640117 Y 3.T 22/2-2 In 8/2

International cooperation and competition in civilian space activities

Corporate Source: United States. Congress. Office of Technology Assessment.

Washington, D.C. : Congress of the U.S., Office of Technology Assessment : For sale by the Supt. of Docs., U.S. G.P.O., 1985. x, 472 p. : ill., maps ; 26 cm.

Publication Date(s): 1985

LCCN: gp 85023884

Price: \$17.00

Place of Publication: District of Columbia GPO Item No.: 1070-M

Stock No.: 052-003-00958-7; GPO

Technical Report No.: OTA-ISC-239

Local Call No.: TL789.8.U5I569

Languages: English

Document Type: Monograph

Geographic Location: United States

"July 1985"--P. [4] of cover. "OTA-ISC-239"--P. [4] of cover. Includes bibliographical references and index.

Descriptors: Space sciences-International cooperation; Space industrialization-International cooperation; Reusable space vehicles-Government policy-United States; Artificial satellites in telecommunication

0638029 NAS 1.55-2313

Second Symposium on Space Industrialization proceedings of a symposium sponsored by NASA Marshall Space Flight Center, the American Institute of Aeronautics and Astronautics, and The University of Alabama and held at Huntsville Hilton Inn, Huntsville, Alabama, February 13-15, 1984

Corporate Source: George C. Marshall Space Flight Center. American Institute of Aeronautics and Astronautics. University of Alabama. United States. National Aeronautics and Space Administration. Scientific and Technical Information Branch.

Conference Title: Symposium on Space Industrialization (2nd : Huntsville, Ala.) , 1984 :

Series: NASA conference publication ; 2313

[Washington, D.C.?] : National Aeronautics and Space Administration, Scientific and Technical Information Branch, 1984. 1 v. : ill. ; 28 cm.

Publication Date(s): 1984

LCCN: gp 85021795

Place of Publication: District of Columbia GPO Item No.: 830-H-10 (microfiche)

Technical Report No.: N 85-11011 thru N 85-11057

Languages: English

Document Type: Monograph

"N85-11011 thru N85-11057"--Microfiche header. Includes bibliographies. Microfiche.~ [Washington, D.C.? :~ National Aeronautics and Space Administration],~ 1985.~ 5 microfiches ; 11 x 15 cm.

Descriptors: Space stations-Industrial applications-Congresses; Artificial satellites in telecommunication-Congresses

0496955 Y 4.Sci 2-99/30

Landsat commercialization : hearing before the Subcommittee on Natural Resources, Agriculture Research, and Environment and the Subcommittee on Space Science and Application of the Committee on Science and Technology, U.S. House of Representatives, Ninety-ninth Congress, first session, June 13, 1985

Corporate Source: United States. Congress. House. Committee on Science and Technology. Subcommittee on Natural Resources, Agriculture Research, and Environment.

Corporate Source: United States. Congress. House. Committee on Science and Technology. Subcommittee on Space Science and Applications.

Washington : U.S. G.P.O., 1985. ill, 81 p. : ill. ; 24 cm.

Publication Date(s): 1985

LCCN: gp 86007720

Place of Publication: District of Columbia GPO Item No.: 1025-A-1, 1025-A-2 (microfiche)

Technical Report No.: No. 30 (United States. Congress. House. Committee on Science and Technology)

Languages: English

Document Type: Monograph.

Geographic Location: United States

Distributed to some depository libraries in microfiche.

Shipping list no.: 85-1069-P. "No. 30."

Descriptors: Eosat; Landsat satellites

## DIALOG File 66: GPO MONTHLY CATALOG - JUL 1976 TO MAY 1986

0234518 NAS 1.2-Sy 7  
Establishment of centers for the commercial development of space

Corporate Source: United States. National Aeronautics and Space Administration.

Washington, D.C. : National Aeronautics and Space Administration, 1985. 2 p. ; 28 cm.

Publication Date(s): 1985

LCCN: gp 85019492

Place of Publication: District of Columbia GPO Item No.:

830-C

Languages: English

Document Type: Monograph

Descriptors: Astronautics

0231217 Y 4.C 73/7-S.prt.99-16

Insurance and the commercialization of space /.printed at the direction of Hon. John C. Danforth for the use of the Committee on Commerce, Science, and Transportation, United States Senate

Corporate Source: United States. Congress. Senate. Committee on Commerce, Science, and Transportation.

Series: S. prt ; 99-16; United States.; Congress 1985.); Senate, S. prt. ;

Washington : U.S. G.P.O., 1985. ix, 43 p. : ill. ; 24 cm.

Publication Date(s): 1985

LCCN: gp 85016191

Place of Publication: District of Columbia GPO Item No.: 1041-A, 1041-B (microfiche)

Languages: English

Document Type: Monograph

Geographic Location: United States

At head of title: 99th Congress, 1st session. Committee print. Distributed to some depository libraries in microfiche. "March 1985." Includes bibliographical references.

Descriptors: Insurance-United States; Insurance, Government risks-United States; Space industrialization

0228461 NAS 1.26-175401

Manufacturing in space : fluid dynamics numerical analysis. prepared for NASA Headquarters by S.J. Robertson

Robertson, S. James.

Corporate Source: United States. National Aeronautics and Space Administration. Huntsville Research & Engineering Center.

Series: LMSC-HREC TR ; D 951333; NASA-CR ; 175401; NASA contractor report ; 175401.

Washington, DC : The Headquarters, [1984] 1 v. : ill. ; 28 cm.

Publication Date(s): 1984

LCCN: gp 85013435

Place of Publication: District of Columbia GPO Item No.: 830-H-14 (microfiche)

Technical Report No.: N 84-19748

Languages: English

Document Type: Monograph

"Final report." "Lockheed Missiles & Space Company, Inc., Huntsville Research & Engineering Center." "February 1984."

Includes bibliographical references. Microfiche.~ [Washington, D.C.? :~ National Aeronautics and Space Administration,~ 1984].~ 1 microfiche ; 11 x 15 cm.

Descriptors: Space stations-Industrial applications; Fluid dynamics (Space environment)

0228319 NAS 1.26-173698

Space station needs, attributes, and architectural options commercial opportunities in space /.prepared by H.L. Wolbers, Jr

Wolbers, H. L.

Corporate Source: United States. National Aeronautics and Space Administration. McDonnell Douglas Astronautics Company-Huntington Beach.

Series: NASA-CR ; 173698; NASA contractor report ; 173698.

[Washington, D.C.? : National Aeronautics and Space Administration, 1983] 1 v. : ill. ; 28 cm.

Publication Date(s): 1983

LCCN: gp 85013293

Place of Publication: District of Columbia GPO Item No.: 830-H-14 (microfiche)

Technical Report No.: N 84-27788

Languages: English

Document Type: Monograph

"McDonnell Douglas Astronautics Company-Huntington Beach."

"April 1983." Includes bibliographical references. Microfiche.~ [Washington, D.C.? :~ National Aeronautics and Space Administration,~ 1984].~ 2 microfiches ; 11 x 15 cm.

Descriptors: Space stations; Large space structures (Astronautics)

0228296 NAS 1.26-173594

Presentation of opportunities for the chemical industry to become involved in space experimentation final report /. prepared for National Aeronautics and Space Administration, NASA Headquarters by Edmund Young and Associates

Corporate Source: United States. National Aeronautics and Space Administration. Edmond Young and Associates.

Series: NASA-CR ; 173594; NASA contractor report ; 173594.

Washington, D.C.? : The Administration, [1984- ] v. : ill. ; 28 cm.

Publication Date(s): 1984-9999

LCCN: gp 85013270

Place of Publication: District of Columbia GPO Item No.: 830-H-14 (microfiche)

Technical Report No.: N 84-25776

Languages: English

Document Type: Monograph

Geographic Location: United States

"February 1984." Microfiche.~ [Washington, D.C.? :~ National  
(cont. next page)

## DIALOG File 66: GPO MONTHLY CATALOG - JUL 1976 TO MAY 1986

Aeronautics and Space Administration,~ 1984].~ microfiches ;  
11 x 15 cm.

Contents Note: pt. 1. A portion of the study to encourage  
and facilitate industrial investment and involvement in space.

Descriptors: Chemical Industry-United States; Catalysts;  
Cosmochemistry

0228272 NAS 1.26-173517

Materials Processing in Space Workshop minutes, October  
27-28, 1982

Corporate Source: Materials Processing in Space Workshop  
(1982 ; Redondo Beach, Calif.)

Corporate Source: TRW Defense and Space Systems Group,  
United States. National Aeronautics and Space Administration.  
Series: NASA-CR ; 173517; NASA contractor report ; 173517.

Redondo Beach, Calif. : TRW, [1982] 1 v. : ill. ; 28 cm.

Publication Date(s): 1982

LCCN: gp 85013246

Place of Publication: California GPO Item No.: 830-H-14  
(microfiche)

Technical Report No.: N 84-24601

Languages: English

Document Type: Monograph

"Part of the Space Station Needs, Attributes and  
Architectural Options study that TRW is performing for NASA."

"N84-24601"--Microfiche header. Microfiche.~ [Washington,  
D.C.? :~ National Aeronautics and Space Administration,~  
1984].~ 1 microfiche ; 11 x 15 cm.

Descriptors: Materials Processing in Space Workshop; (1982  
; Redondo Beach, Calif.); Space stations-Industrial  
applications

0227637 GS 4.110-98-575

An Act to Facilitate Commercial Space Launches, and for  
Other Purposes

Uniform Title: Commercial Space Launch Act

Corporate Source: United States.

[Washington, D.C.? : U.S. G.P.O. : Supt. of Docs., U.S.  
G.P.O., distributor], 1985. [10] p. ; 24 cm.

Publication Date(s): 1985

LCCN: gp 85012611

Price: \$1.00

Place of Publication: District of Columbia GPO Item No.: 575

Stock No.: 022-003-96330-8; GPO

Technical Report No.: Public Law 98-575

Languages: English

Document Type: Monograph

Geographic Location: United States

Caption title. "Public Law 98-575." "98 Stat. 3055." "Oct.  
30, 1984, (H.R. 3942)"

Descriptors: Astronautics and state-United States; Launch  
vehicles (Astronautics)

0226334 S 1.71/4-622

Commercialization of outer space : October 9, 1984

Marshall, Harry R.

Corporate Source: United States. Dept. of State. Office of  
Public Communication. Editorial Division.

Series: Current policy ; no. 622; United States.; Dept. of  
State.; Bureau of Public Affairs. Current policy ;  
Washington, D.C. : U.S. Dept. of State, Bureau of Public  
Affairs, Office of Public Communication, Editorial Division,  
[1984] 6 p. ; 28 cm.

Publication Date(s): 1984

LCCN: gp 85011307

Place of Publication: District of Columbia GPO Item No.:  
877-C

Languages: English

Document Type: Monograph

Geographic Location: United States

Caption title.

Descriptors: Outer space-Exploration-United States-  
Addresses, essays, lectures; Space industrialization-  
Addresses, essays, lectures

0226231 NAS 1.26-173688

Space station commercial user development

Corporate Source: United States. National Aeronautics and  
Space Administration. Space Station Task Force. Booz, Allen &  
Hamilton.

Washington, D.C. : National Aeronautics and Space  
Administration, Space Station Task Force ; Arlington, Va. :  
Booz-Allen & Hamilton Inc., [1984] 1 v. : ill. ; 28 cm.

Publication Date(s): 1984

LCCN: gp 85011204

Place of Publication: District of Columbia

Technical Report No.: N 84-27756

Languages: English

Document Type: Monograph

Microfiche. [Washington, D.C. : National Aeronautics and  
Space Administration, 1984?]. 1 microfiche ; 11 x 15 cm.

"January 20, 1984." "N84-27756"--Microfiche header.

"Contract NASW-3775."

Descriptors: Space stations-Industrial applications

0224553 Y 4.Sci 2-98/108

Initiatives to promote space commercialization : hearing  
before the Subcommittee on Space Science and Applications of  
the Committee on Science and Technology, U.S. House of  
Representatives, Ninety-eighth Congress, second session, June  
19, 1984

Corporate Source: United States. Congress. House. Committee  
on Science and Technology. Subcommittee on Space Science and  
Applications.

Washington : U.S. G.P.O., 1984. ill, 73 p. ; 24 cm.

Publication Date(s): 1984

(cont. next page)



## DIALOG File 66: GPO MONTHLY CATALOG - JUL 1976 TO MAY 1986

LCCN: gp 85009526  
Place of Publication: District of Columbia GPO Item No.:  
1025-A-1, 1025-A-2 (microfiche)  
Technical Report No.: No. 108 (United States. Congress.  
House. Committee on Science and Technology)  
Languages: English  
Document Type: Monograph  
Geographic Location: United States  
Distributed to some depository libraries in microfiche.  
"No. 108."  
Descriptors: Space industrialization

0224472 Y 4.C 73/7-S.hrg.98-1105  
**Commercial Space Launch Act : hearing before the  
Subcommittee on Science, Technology, and Space of the  
Committee on Commerce, Science, and Transportation, United  
States Senate, Ninety-eighth Congress, first session, on S.  
2931 ... September 6, 1984**  
Corporate Source: United States. Congress. Senate. Committee  
on Commerce, Science, and Transportation. Subcommittee on  
Science, Technology, and Space.  
Series: S. hrg. ; 98-1105; United States.; Congress 1984).;  
Senate. S. hrg ;  
Washington : U.S. G.P.O., 1984. iii, 69 p. ; 24 cm.  
Publication Date(s): 1984  
LCCN: gp 85009445  
Place of Publication: District of Columbia GPO Item No.:  
1041-A, 1041-B (microfiche)  
Technical Report No.: Serial no. 98-105 (United States.  
Congress. Senate. Committee on Commerce, Science, and  
Transportation)  
Languages: English  
Document Type: Monograph  
Geographic Location: United States  
Distributed to some depository libraries in microfiche.  
"Serial no. 98-105."  
Descriptors: Astronautics and state-United States; Launch  
vehicles (Astronautics)

0224428 Y 3.T 22/2-2 C 49/2  
**Civilian space stations and the U.S. future in space**  
Corporate Source: United States. Congress. Office of  
Technology Assessment.  
Washington, D.C. : Congress of the U.S., Office of  
Technology Assessment : For sale by the Supt. of Docs., U.S.  
G.P.O., 1984. xi, 234 p. : ill. ; 26 cm.  
Publication Date(s): 1984  
LCCN: gp 85009401  
Price: \$7.50  
Place of Publication: District of Columbia GPO Item No.:  
1070-M  
Stock No.: 052-003-00969-2; GPO  
Technical Report No.: OTA-STI-241  
Languages: English  
Document Type: Monograph

Geographic Location: United States  
"November 1984"--P. [4] of cover. Includes bibliographical  
references and index.  
Descriptors: Space stations-Government policy-United States  
Space sciences-Government policy-United States; Aeronautics  
and state-United States; Space industrialization

0219330 Y 1.1/5-98-656  
**Commercial space launches : report (to accompany H.R. 3942)**  
Corporate Source: United States. Congress. Senate. Committee  
on Commerce, Science, and Transportation.  
Series: Report / 98th Congress, 2d session, Senate ; 98-656  
United States.; Congress 1984).; Senate. Report ;  
[Washington, D.C.? : U.S. G.P.O., 1984] 19 p. ; 24 cm.  
Publication Date(s): 1984  
LCCN: gp 85003749  
Place of Publication: District of Columbia GPO Item No.:  
1008-C, 1008-D (microfiche)  
Languages: English  
Document Type: Monograph  
Geographic Location: United States  
Caption title. Distributed to some depository libraries in  
microfiche. "October 3 ... 1984."  
Descriptors: Launch vehicles (Astronautics); Astronautics  
and state-United States

0217174 Y 4.Sci 2-98/85  
**The Expendable Launch Vehicle Commercialization Act :  
hearings before the Subcommittee on Space Science and  
Applications of the Committee on Science and Technology, U.S.  
House of Representatives, Ninety-eighth Congress, first and  
second sessions, November 18, 1983; March 29, 1984**  
Corporate Source: United States. Congress. House. Committee  
on Science and Technology. Subcommittee on Space Science and  
Applications.  
Washington : U.S. G.P.O., 1984. iii, 117 p. ; 24 cm.  
Publication Date(s): 1984  
LCCN: gp 84024774  
Place of Publication: District of Columbia GPO Item No.:  
1025-A-1, 1025-A-2 (microfiche)  
Technical Report No.: No. 85 (United States. Congress.  
House. Committee on Science and Technology)  
Languages: English  
Document Type: Monograph  
Geographic Location: United States  
Distributed to some depository libraries in microfiche.  
"No. 85."  
Descriptors: United States; Dept. of Transportation;  
Reusable space vehicles-Government policy-United States;  
Business enterprises-United States

## DIALOG File 66: GPO MONTHLY CATALOG - JUL 1976 TO MAY 1986

0214109 Y 4.Sci 2-L 22

The Land Remote-Sensing Commercialization Act of 1984--H.R.4836 and H.R. 5155 : hearing before the Subcommittee on Natural Resources, Agriculture Research, and Environment and the Subcommittee on Space Science and Applications of the Committee on Science and Technology, U.S. House of Representatives, Ninety-eighth Congress, second session, March 6, 1984

Corporate Source: United States. Congress. House. Committee on Science and Technology. Subcommittee on Natural Resources, Agriculture Research, and Environment.

Corporate Source: United States. Congress. House. Committee on Science and Technology. Subcommittee on Space Science and Applications.

Washington : U.S. G.P.O., 1984. v, 165 p. : ill. ; 24 cm.

Publication Date(s): 1984

LCCN: gp 84021709

Place of Publication: District of Columbia GPO Item No.: 1025-A-1, 1025-A-2 (microfiche)

Languages: English

Document Type: Monograph

Distributed to some depository libraries in microfiche.

Descriptors: Landsat satellites-Economic aspects- United States; Industry and state-United States; Business enterprises -United States

0213920 Y 1.1/8-98-816

Commercial Space Launch Act : report (to accompany H.R. 3942) (including cost estimate of the Congressional Budget Office)

Corporate Source: United States. Congress. House. Committee on Science and Technology.

Series: Report / 98th Congress, 2d session, House of Representatives ; 98-816; United States.; Congress 1984).; House. Report ;

[Washington, D.C.? : U.S. G.P.O., 1984] 24 p. ; 24 cm.

Publication Date(s): 1984

LCCN: gp 84021520

Place of Publication: District of Columbia GPO Item No.: 1008-C, 1008-D (microfiche)

Languages: English

Document Type: Monograph

Geographic Location: United States

Caption title. Distributed to some depository libraries in microfiche. "May 31, 1984."

Descriptors: Astronautics and state-United States; Launch vehicles (Astronautics)

0212495 Y 4.C 73/7-S.hrg.98-747

Landsat commercialization : hearing before the Subcommittee on Science, Technology, and Space of the Committee on Commerce, Science, and Transportation, United States Senate, Ninety-eighth Congress, second session, on S. 1855 ... S. 1861 ... S. 2292 ... March 22, 1984

Corporate Source: United States. Congress. Senate. Committee

on Commerce, Science, and Transportation. Subcommittee on Science, Technology, and Space.

Series: S. hrg. ; 98-747; United States.; Congress 1984).; Senate. S. hrg. ;

Washington : U.S. G.P.O., 1984. iii, 137 p. : ill. ; 24 cm.

Publication Date(s): 1984

LCCN: gp 84020095

Place of Publication: District of Columbia GPO Item No.: 1041-A, 1041-B (microfiche)

Technical Report No.: Serial no. 98-69 (United States. Congress. Senate. Committee on Commerce, Science, and Transportation)

Languages: English

Document Type: Monograph

Geographic Location: United States

Distributed to some depository libraries in microfiche.

Includes bibliographical references. "Serial no. 98-69."

Descriptors: Landsat satellites; Business enterprises-Government policy-United States

0211012 C 3.24/8-MC 82-I-37 B-6 (P)

1982 census of manufactures.Preliminary report. Industry series.Space vehicle equipment, N.E.C. (industry 3769)

Variante Title: Industry series, space vehicle equipment, N.E.C. (industry 3769); Space vehicle equipment, N.E.C. (industry 3769)

Uniform Title: Census of manufactures (1982) Preliminary report

Corporate Source: United States. Bureau of the Census.

[Washington, D.C. : U.S. Dept. of Commerce, Bureau of the Census : For sale by Supt. of Docs., U.S. G.P.O., 1984] 7 p. ; 28 cm.

Publication Date(s): 1984

LCCN: gp 84018612

Price: \$1.00

Place of Publication: District of Columbia GPO Item No.: 135

Stock No.: 003-024-90554-0; GPO

Technical Report No.: MC 82-I-37 B-6 (P)

Languages: English

Document Type: Monograph

Geographic Location: United States

Caption title. "Issued May 1984." "MC82-I-37B-6(P)"

Descriptors: Space vehicles-Equipment and supplies-Trade and manufacture-Statistics; United States-Manufactures-Statistics

0208534 Y 4.C 73/7-S.hrg.98-259; Y 4.C 73/7-S.hrg.98-259/pt.2

Role of technology in promoting industrial competitiveness : hearings before the Subcommittee on Science, Technology, and Space of the Committee on Commerce, Science, and Transportation, United States Senate, Ninety-eighth Congress, first session ...

Corporate Source: United States. Congress. Senate. Committee on Commerce, Science, and Transportation. Subcommittee on

(cont. next page)

## DIALOG File 66: GPO MONTHLY CATALOG - JUL 1976 TO MAY 1986

Science, Technology, and Space.

Series: S. hrg. ; 98-259, pt. 2.; United States.; Congress 1983).; Senate. S. hrg. ;

Washington : U.S. G.P.O., 1983- v. : ill. ; 24 cm.

Publication Date(s): 1983

LCCN: gp 84016134

Place of Publication: District of Columbia GPO Item No.: 1041-A, 1041-B (microfiche)

LC Call No.: KF26.C697 1983c Dewey Call No.: 344.73/095;

347.30495 (Dewey Edition No.: 19)

Languages: English

Document Type: Monograph

Geographic Location: United States

Distributed to some depository libraries in microfiche. "November 23, December 6 and 7, 1983"--Pt. 2. Includes bibliographical references.

Contents Note: pt. 2. S. 1286 ....

Descriptors: Technological innovations-Law and legislation-United States; Research, Industrial-United States; Production engineering

0197976 Y 4.Sci 2-98/R

Space commercialization : report / prepared by the Subcommittee on Space Science and Applications transmitted to the Committee on Science and Technology, U.S. House of Representatives, Ninety-eighth Congress, first session  
Smith, Gordon A.

Corporate Source: United States. Congress. House. Committee on Science and Technology. Subcommittee on Space Science and Applications.

Washington : U.S. G.P.O., 1983. 1i, 35 p. ; 24 cm.

Publication Date(s): 1983

LCCN: gp 84007761

Place of Publication: District of Columbia GPO Item No.: 1025-A-1, 1025-A-2 (microfiche)

Technical Report No.: Serial R (United States. Congress. House. Committee on Science and Technology)

Languages: English

Document Type: Monograph

Geographic Location: United States

At head of title: Committee print. Distributed to some depository libraries in microfiche. "October 1983." "Serial R."

Descriptors: Reusable space vehicles; Business enterprises-United States; Reusable space vehicles; Business enterprises-United States

0197889 Y 4.C 73/7-S.prt.98-102

Policy and legal issues involved in the commercialization of space / printed at the direction of Bob Packwood, for the use of the Committee on Commerce, Science, and Transportation, United States Senate

Corporate Source: United States. Congress. Senate. Committee on Commerce, Science, and Transportation.

Series: S. prt ; 98-102; S. prt ; 98-102; United States.;

Congress 1983).; Senate. S. prt. ;; United States.; Congress 1983).; Senate. S. prt. ;

Washington : U.S. G.P.O., 1983. x, 52 p. ; 24 cm.

Publication Date(s): 1983

LCCN: gp 84007674

Place of Publication: District of Columbia GPO Item No.: 1041-A, 1041-B (microfiche)

Languages: English

Document Type: Monograph

Geographic Location: United States

At head of title: 98th Congress, 1st session. Committee print. Distributed to some depository libraries in microfiche. "September 23, 1983." Includes bibliographical references.

Descriptors: Reusable space vehicles; Business enterprises-United States; Reusable space vehicles; Business enterprises-United States

0196271 Y 4.Sci 2-98/23

Space commercialization : hearings before the Subcommittee on Space Science and Applications of the Committee on Science and Technology, U.S. House of Representatives, Ninety-eighth Congress, first session, May 3, 4, 17, 18, 1983

Corporate Source: United States. Congress. House. Committee on Science and Technology. Subcommittee on Space Science and Applications.

Washington, D.C. : U.S. G.P.O., 1983. iii, 385 p. : ill. ; 24 cm.

Publication Date(s): 1983

LCCN: gp 84006056

Place of Publication: District of Columbia GPO Item No.: 1025-A-1, 1025-A-2 (microfiche)

Technical Report No.: No. 23 (United States. Congress. House. Committee on Science and Technology)

Languages: English

Document Type: Monograph

Geographic Location: United States

Distributed to some depository libraries in microfiche. Includes bibliographical references.

Descriptors: Reusable space vehicles-Government policy-United States; Business enterprises-United States; Reusable space vehicles-Government policy-United States; Business enterprises-United States

0196208 Y 4.F 76/1-Sp 1/3/982

The second U.N. Conference on the Peaceful Uses of Outer Space (UNISPACE 1982), August 9-21, 1982 : report submitted to the Committee on Foreign Affairs, U.S. House of Representatives

Variant Title: The Second UN Conference on the Peaceful Uses of Outer Space

Corporate Source: United States. Congress. House. Committee on Foreign Affairs.

(cont. next page)

## DIALOG File 66: GPO MONTHLY CATALOG - JUL 1976 TO MAY 1986

Conference Title: United Nations Conference on the Exploration and Peaceful Uses of Outer Space (2nd : Vienna, Austria) , 1982 :

Washington : U.S. G.P.O., 1983. vii, 27 p. ; 24 cm.

Publication Date(s): 1983

LCCN: gp 84005993

Place of Publication: District of Columbia GPO Item No.: 1017-A, 1017-B (microfiche)

Languages: English

Document Type: Monograph

Geographic Location: United States

At head of title: 97th Congress, 2d session. Committee print. Distributed to depository libraries in microfiche.

Descriptors: Space law; Artificial satellites in telecommunication; Remote sensing; Space stations-Industrial applications; Space law; Artificial satellites in telecommunication; Remote sensing; Space stations-Industrial applications

0194372 Y 4.C 73/7-S.hrg.98-259

Role of technology in promoting industrial competitiveness : hearings before the Subcommittee on Science, Technology, and Space of the Committee on Commerce, Science, and Transportation, United States Senate, Ninety-eighth Congress, first session, on S. 428 ... S. 632 ... S. 1286 ... June 21 and 23, 1983

Corporate Source: United States. Congress. Senate. Committee on Commerce, Science, and Transportation. Subcommittee on Science, Technology, and Space.

Series: S. hrg. ; 98-259; S. hrg. ; 98-259; United States.; Congress 1983).; Senate. S. hrg. ;; United States.; Congress 1983).; Senate. S. hrg. ;

Washington : U.S. G.P.O., 1983. iv, 143 p. : ill. ; 24 cm.

Publication Date(s): 1983

LCCN: gp 84004157

Place of Publication: District of Columbia GPO Item No.: 1041-A, 1041-B (microfiche)

Technical Report No.: Serial no. 98-29 (United States. Congress. Senate. Committee on Commerce, Science, and Transportation)

Languages: English

Document Type: Monograph

Geographic Location: United States

Distributed to some depository libraries in microfiche. Includes bibliographical references.

Descriptors: Technological innovations-United States; Research and development contracts, Government-United States; Technology assessment-United States; Industry and state-United States; Technological innovations-United States; Research and development contracts, Government-United States; Technology assessment-United States; Industry and state-United States

0159929 NAS 1.15-83106

The Utilization of nonterrestrial materials : proceedings of a workshop held at Palo Alto, California, June 1977

Corporate Source: United States. National Aeronautics and Space Administration. United States. Office of Aeronautics and Space Technology.

Series: NASA technical memorandum ; 83106

Washington, D.C. : National Aeronautics and Space Administration, Scientific and Technical Information Branch ; [Springfield, Va. : For sale by the National Technical Information Service], 1981. vii, 188 p. : ill. ; 27 cm.

Publication Date(s): 1981

LCCN: gp 82019577

Place of Publication: District of Columbia GPO Item No.: 830-D (microfiche)

Local Call No.: TL797.U89

Languages: English

Document Type: Monograph

Sponsored by NASA Headquarters, performed by their Office of Aeronautics and Space Technology. "March 1981"--Cover. Includes bibliographical references.

Descriptors: Space stations-Industrial applications; Outer space-Exploration; Mineral industries

0132693 NAS 1.55-2186

Capacitor technologies, applications and reliability : proceedings of a symposium sponsored by NASA Marshall Space Flight Center and IEEE Components, Hybrids and Manufacturing Technology Society and held at Marshall Space Flight Center, February 24-25, 1981

Corporate Source: IEEE Components, Hybrids and Manufacturing Technology Society.

Conference Title: Symposium on Capacitor Technologies, Applications and Reliability (1981 : George C. Marshall Space Flight Center)

Series: NASA conference publication ; 2186

Washington, D.C. : National Aeronautics and Space Administration, Scientific and Technical Information Branch ; [Springfield, Va. : For sale by the National Technical Information Service], 1981. vi, 165 p. : ill. ; 27 cm.

Publication Date(s): 1981

LCCN: gp 81014257

Place of Publication: District of Columbia

Languages: English

Document Type: Monograph

Includes bibliographical references.

Descriptors: Capacitors-Congresses

0122601 Y 4.Sci 2-96/132

H.R. 7412 : the Space Industrialization Act of 1980 : hearings before the Subcommittee on Space Science and Applications of the Committee on Science and Technology, U.S. House of Representatives, Ninth-sixth Congress, second

(cont. next page)

## DIALOG File 66: GPO MONTHLY CATALOG - JUL 1978 TO MAY 1986

session, June 11-12, 1980

Variant Title: Space Industrialization Act of 1980

Corporate Source: United States. Congress. House. Committee on Science and Technology. Subcommittee on Space Science and Applications.

Washington : U.S. G.P.O., 1980. 111, 88 p. : 24 cm.

Publication Date(s): 1980

LCCN: gp 81004165

Place of Publication: District of Columbia GPO Item No.: 1025-A

Technical Report No.: No. 132 (United States. Congress. House. Committee on Science and Technology)

Languages: English

Document Type: Monograph

Geographic Location: United States

"No. 132."

Descriptors: Space Industrialization Corporation; Space stations-Industrial applications-Finance; Astronautics and state-United States

0116591 Y 4.C 73/7-96-105

Industrial applications of recombinant DNA techniques : hearing before the Subcommittee on Science, Technology, and Space of the Committee on Commerce, Science, and Transportation, United States Senate, Ninety-sixth Congress, second session ... May 20, 1980

Corporate Source: United States. Congress. Senate. Committee on Commerce, Science, and Transportation. Subcommittee on Science, Technology, and Space.

Series: Serial - Senate. Committee on Commerce, Science, and Transportation ; no. 96-105; United States.; Congress.; Senate.; Committee on Commerce, Science, and Transportation. Serial, 96th Congress ;

Washington : U.S. Govt. Print. Off., 1980. 111, 90 p. : 111. ; 24 cm.

Publication Date(s): 1980

LCCN: gp 80024933

Place of Publication: District of Columbia GPO Item No.: 1041

Languages: English

Document Type: Monograph

Geographic Location: United States

Descriptors: Recombinant DNA; Recombinant DNA-Research; Industry and state-United States

0101992 GA 1.13-FGMSD-80-32

U.S. must spend more to maintain lead in space technology : report / by the Comptroller General of the United States

Corporate Source: United States. General Accounting Office. [Washington] : General Accounting Office, 1980. 7, 18 p. ; 27 cm.

Publication Date(s): 1980

LCCN: gp 80010332

Place of Publication: District of Columbia GPO Item No.: 546-D (microfiche)

Languages: English

Document Type: Monograph

Geographic Location: United States

"FGMSD-80-32." "B-197413." Jan. 31, 1980.

Descriptors: United States; National Aeronautics and Space Administration; Space stations-Industrial applications

0101018 Y 4.Sci 2-96/47

The Space Industrialization act of 1979 : hearings before the Subcommittee on Space Science and Applications of the Committee on Science and Technology, U.S. House of Representatives, Ninety-sixth Congress, first session, on H.R. 2337 ...

Corporate Source: United States. Congress. House. Committee on Science and Technology. Subcommittee on Space Science and Applications.

Series: Serial - House. Committee on Science and Technology ; no. 96-47; United States.; Congress.; House.; Committee on Science and Technology. Serial, 96th Congress ;

Washington : U.S. Govt. Print. Off., 1979. 111, 288 p. : 111. ; 24 cm.

Publication Date(s): 1979

LCCN: gp 80009358

Place of Publication: District of Columbia GPO Item No.: 1025-A

Languages: English

Document Type: Monograph

Geographic Location: United States

Hearings held May 22-June 27, 1979. Includes bibliographical references.

Descriptors: Space Industrialization Corporation; Space stations-Industrial applications

0090202 C 3.24/8-MC 77-I-37 B-6 (P)

1977 census of manufactures : industry series, space vehicle equipment, N.E.C., SIC 3769

Variant Title: Industry series, space vehicle equipment, N.E.C., SIC 3769; Space vehicle equipment, N.E.C., SIC 3769

Corporate Source: United States. Bureau of the Census.

Series: MC 77-I ; 37 B-6 (P)

Washington : Dept. of Commerce, Bureau of the Census : for sale by Subscriber Services (Publications), Bureau of the Census, 1979. 9 p. ; 28 cm.

Publication Date(s): 1979

LCCN: gp 79022094

Place of Publication: District of Columbia GPO Item No.: 135

Languages: English

Document Type: Monograph

Geographic Location: United States

Issued June 1979. Preliminary report.

Descriptors: Space vehicles-Equipment and supplies-Statistics; United States-Manufactures-Statistics

## DIALOG File 66: GPO MONTHLY CATALOG - JUL 1978 TO MAY 1986

0087526 C 3.24/8-MC 77-I-37 B-5 (P)  
1977 census of manufactures : industry series, space propulsion units and parts, SIC 3764  
Variant Title: Industry series, space propulsion units and parts, SIC 3764; Space propulsion units and parts, SIC 3764  
Corporate Source: United States. Bureau of the Census.  
Series: MC 77-I ; 37 B-5 (P)  
Washington : Dept. of Commerce, Bureau of the Census : for sale by Subscriber Services (Publications), Bureau of the Census, 1979. 8 p. ; 28 cm.  
Publication Date(s): 1979  
LCCN: gp 79019418  
Place of Publication: District of Columbia GPO Item No.: 135  
Languages: English  
Document Type: Monograph  
Geographic Location: United States  
Issued June 1979. Preliminary report.  
Descriptors: Guided missile industries-United States-Statistics; United States-Manufactures-Statistics

0087525 C 3.24/8-MC 77-I-37 B-4 (P)  
1977 census of manufactures : industry series, guided missiles and space vehicles, SIC 3761  
Variant Title: Industry series, guided missiles and space vehicles, SIC 3761; Guided missiles and space vehicles, SIC 3761  
Corporate Source: United States. Bureau of the Census.  
Series: MC 77-I ; 34 B-4 (P)  
Washington : Dept. of Commerce, Bureau of the Census : for sale by Subscriber Services (Publications), Bureau of the Census, 1979. 8 p. ; 28 cm.  
Publication Date(s): 1979  
LCCN: gp 79019417  
Place of Publication: District of Columbia GPO Item No.: 135  
Languages: English  
Document Type: Monograph  
Geographic Location: United States  
Issued June 1979. Preliminary report.  
Descriptors: Guided missile industries-United States-Statistics; Space vehicles-Statistics; United States-Manufactures-Statistics

0074083 GA 1.13-LCD-78-337  
Government space leased to commercial activities by agencies other than the General Services Administration : report /by the Comptroller General of the United States  
Corporate Source: United States. General Accounting Office.  
Washington : General Accounting Office, 1978. 35 p. : ill. ; 27 cm.  
Publication Date(s): 1978  
LCCN: gp 79005974  
Place of Publication: District of Columbia GPO Item No.: 546-D (microfiche)  
Languages: English  
Document Type: Monograph

Geographic Location: United States  
"LCD-78-337." "B-114827." Issued Oct. 13, 1978.  
Descriptors: Building leases-United States; United States-Public buildings

0050504 NAS 1.15-78137  
Space processing applications rocket project SPAR III : final report  
Variant Title: SPAR : Space processing applications rocket project  
Corporate Source: United States. George C. Marshall Space Flight Center, Huntsville, Ala.  
Corporate Source: United States. National Aeronautics and Space Administration. Scientific and Technical Information Office.  
Series: NASA technical memorandum ; 78137  
[Washington] : National Aeronautics and Space Administration. Scientific and Technical Information Office ; Springfield, Va. : for sale by the National Technical Information Service, 1978. 184 p. in various pagings : ill. ; 27 cm.  
Publication Date(s): 1978  
LCCN: gp 78026325  
Place of Publication: District of Columbia GPO Item No.: 830-D (microfiche)  
Languages: English  
Document Type: Monograph  
Issued Jan. 1978. Includes bibliographical references.  
Descriptors: Space stations-Industrial applications

0036355 Y 4.Sci 2-95/26  
Space industrialization : hearing before the Subcommittee on Space Science and Applications of the Committee on Science and Technology, U.S. Congress, first session, September 29, 1977  
Corporate Source: United States. Congress. House. Committee on Science and Technology. Subcommittee on Space Science and Applications.  
Series: Serial - House, Committee on Science and Technology ; no. 95-26; United States.; Congress.; House.; Committee on Science and Technology. Serial, 95th Congress ; Washington : U.S. Govt. Print. Off., 1977. iii, 204 p. : ill. ; 24 cm.  
Publication Date(s): 1977  
LCCN: gp 78012174  
Place of Publication: District of Columbia GPO Item No.: 1025-A  
Languages: English  
Document Type: Monograph  
Geographic Location: United States  
Includes bibliographical references.

## DIALOG File 66: GPO MONTHLY CATALOG - JUL 1976 TO MAY 1986

0009720 Y 4.Ae 8-Sp 1/15

Space processing : hearing before the Subcommittee on  
Aerospace Technology and National Needs of the Committee on  
Aeronautical and Space Sciences, United States Senate,  
Ninety-fourth Congress, second session, June 17, 1976

Corporate Source: United States. Congress. Senate. Committee  
on Aeronautical and Space Sciences. Subcommittee on Aerospace  
Technology and National Needs.

Washington : U.S. Govt. Print. Off., 1976. iii, 88 p. : ill.  
; 24 cm.

Publication Date(s): 1976

LCCN: gp 76009754

Price: \$1.10

Place of Publication: District of Columbia

Languages: English

Document Type: Monograph

Item 1032-A Includes bibliographical references.

Descriptors: Space stations-Industrial applications

ORIGINAL PAGE IS  
OF POOR QUALITY

### NTIS DATABASE

The NTIS (National Technical Information Service) database consists of government-sponsored research, development, and engineering plus analyses prepared by federal agencies, their contractors or grantees. It is the means by which unclassified, publicly available, unlimited distribution reports are made available for sale by such agencies as NASA, DDC, DOE, HUD, DOT, Department of Commerce and other government agencies.



## DIALOG File 6: NTIS - 84-86/ISS11 (Copr. NTIS)

1168162 N86-12243/9/XAB

**Marketing the Use of the Space Environment for the Processing of Biological and Pharmaceutical Materials**  
(Final rept)

ECON, Inc., Alexandria, VA.

Corp. Source Codes: 085110000; ED782198

Sponsor: National Aeronautics and Space Administration, Washington, DC.

Report No.: NAS 1.26:176334; ECON-81-110; NASA-CR-176334

13 Apr 84 162p

Languages: English

NTIS Prices: PC A08/MF A01 Journal Announcement: GRAI8605; STAR2403

Country of Publication: United States

Contract No.: NASW-3339

The perceptions of U.S. biotechnology and pharmaceutical companies concerning the potential use of the space environment for the processing of biological substances was examined. Physical phenomena that may be important in space-base processing of biological materials are identified and discussed in the context of past and current experiment programs. The capabilities of NASA to support future research and development, and to engage in cooperative risk sharing programs with industry are discussed. Meetings were held with several biotechnology and pharmaceutical companies to provide data for an analysis of the attitudes and perceptions of these industries toward the use of the space environment. Recommendations are made for actions that might be taken by NASA to facilitate the marketing of the use of the space environment, and in particular the Space Shuttle, to the biotechnology and pharmaceutical industries.

Descriptors: \*Biotechnology; \*Pharmacology; Research and development; \*Space manufacturing; Aerospace environments; Drugs; Medical science; Space shuttles; \*Technology utilization

Identifiers: Industries; Cooperative programs; NTISNASA

Section Headings: 60 (Biological and Medical Sciences--Pharmacology); 6B (Biological and Medical Sciences--Bioengineering); 57Q (Medicine and Biology--Pharmacology and Pharmacological Chemistry); 84GE (Space Technology--General); 70E (Administration and Management--Research Program Administration and Technology Transfer); 95C (Biomedical Technology and Human Factors Engineering--Biomedical Instrumentation and Bioengineering); 96A (Business and Economics--Domestic Commerce, Marketing, and Economics)

1156555 N85-33171/8/XAB

**Space Station Automation Study. Automation Requirements Derived from Space Manufacturing Concepts. Volume 2. Technical Report**

(Final rept)

General Electric Co., Philadelphia, PA. Space Systems Div.

Corp. Source Codes: 009193028; GK087134

Sponsor: National Aeronautics and Space Administration, Washington, DC.

Report No.: NAS 1.26:176100; NASA-CR-176100

27 Nov 84 125p

Languages: English

NTIS Prices: PC A10/MF A01 Journal Announcement: GRAI8526; STAR2322

Country of Publication: United States

Contract No.: NAS5-25182

The automation technology required for remote operations, including manufacturing applications were assessed. Over one hundred potential space station missions were assessed through an extensive review of proposed space station experiments and manufacturing concepts. Two manufacturing design concepts were developed: (1) gallium arsenide electroepitaxial crystal production and wafer manufacturing facility; and (2) gallium arsenide VLSI microelectronics chip processing facility. A functional overview of the ultimate design concept incorporating the two manufacturing facilities on space station are provided. The concepts were studied separately. This separation allowed conclusions and results to be determined in independent time frames without dependent cross ties. The conclusions and results are discussed in detail.

Descriptors: \*Automatic control; \*Microelectronics; \*Mission planning; \*Space manufacturing; \*Space stations; Chips (Electronics); Electroepitaxy; Gallium arsenides; Space maintenance; Very large scale integration; Wafers

Identifiers: NTISNASA

Section Headings: 22B (Space Technology--Spacecraft); 84C (Space Technology--Manned Spacecraft); 70E (Administration and Management--Research Program Administration and Technology Transfer); 41P (Manufacturing Technology--Research Program Administration and Technology Transfer)

1145887 N85-29979/O/XAB

**International Space Research Perspectives of Commercialization for German Industry**

Jordan, H. L.

National Aeronautics and Space Administration, Washington, DC.

Corp. Source Codes: 011249000; NC452981

Report No.: NAS 1.15:77657; NASA-TM-77657

Jul 85 31p

Transl. into English of 'Weltraumforschung - Perspektiven der Kommerziellen Nutzung Fur die Deutsche Industrie' Linder Hoeh, West Germany, 19 Oct. 1984 16p. Transl. by Scientific Translation Service, Santa Barbara, CA. Original document prepared by DFVLR, Linder Hoeh, West Germany. Presented at Meeting of the Comm. for the Politics of Res. and Sci., Bonn, 19 Oct. 1984.

Languages: English Document Type: Translation

NTIS Prices: PC A03/MF A01 Journal Announcement: GRAI8522; STAR2319

Country of Publication: Germany, Federal Republic of

Contract No.: NASW-4904

A brief overview of space flight activities is presented. West German contributions to satellite mapping, communication  
(cont. next page)

ORIGINAL PAGE IS  
OF POOR QUALITY

## DIALOG File 6: NTIS - 64-86/ISS11 (Copr. NTIS)

satellites, navigation, Spacelab, diffusion under weightlessness, crystal growth in space, metal bonding, and biochemistry are described. The future of the research in the space station is analyzed.

Descriptors: \*Communication satellites; \*Diffusion; \*Space commercialization; \*Space manufacturing; \*Space stations; \*Spacelab; \*West germany; Biochemistry; Crystal growth; Satellite imagery

Identifiers: \*Foreign technology; Translations; NTISNASAT  
Section Headings: 22A (Space Technology--Astronautics); 84GE (Space Technology--General)

1140820 N85-27928/9/XAB

**In Orbit Infrastructure: Volume 1. Executive Summary**

ERNO Raumfahrttechnik G.m.b.H., Bremen (Germany, F.R.).

Corp. Source Codes: 062971000; E2789907

Sponsor: National Aeronautics and Space Administration, Washington, DC.

Report No.: RX011-002/84-V-1; ESA-CR(P)-2002-V-1

Jul 84 80p

Languages: English

NTIS Prices: PC A05/MF A01 Journal Announcement: GRAI8520; STAR2317

Country of Publication: Germany, Federal Republic of

Contract No.: ESA-5602/83/F-FC(SC)

Based on the identified and projected European mission needs for Earth observation, telecommunications, space processing and scientific missions, mission requirements and in-orbit infrastructure (IOI) element function performances were established. Orbit change, rendezvous and docking, telemanipulator operations, automatic sample exchange, and automatic re-entry elements are applicable for the servicing equipment of a materials processing space platform, the orbital transfer and servicing system, and the re-entry vehicle (REV). Economic and technical arguments favor manned elements (SIS) for launch/servicing/payload exchange/recovery for initial material processing missions in a 500 km/28.5 deg orbit. The introduction of Ariane 5 and REV gives Europe an independent servicing capability with similar launch costs but with higher reliance on automatic systems for rendezvous docking/servicing/payload exchange/recovery. Operational missions using Hermes, although not so economically attractive, provide Europe with an independent manned capacity.

Descriptors: \*European space programs; \*Project planning; \*Space logistics; \*Space maintenance; \*Technological forecasting; Reusable spacecraft; Robotics; Space commercialization; Space rendezvous; Spacecraft docking

Identifiers: \*Foreign technology; NTISNASAE  
Section Headings: 22A (Space Technology--Astronautics); 84A (Space Technology--Astronautics)

1140819 N85-27927/1/XAB

**European Utilization Aspects of a US Manned Space Station. Volume 2**

(Final rept)

Deutsche Forschungs- und Versuchsanstalt fuer Luft- und Raumfahrt e.V., Cologne (Germany, F.R.).

Corp. Source Codes: 062739000; D0696939

Sponsor: National Aeronautics and Space Administration, Washington, DC.

Report No.: ESA-CR(P)-1987-V-2

Apr 83 393p

Prepared in cooperation with MBB GMBH, Bremen, West Germany, Aeritalia Spa, Turin, British Aerospace Aircraft Group, Bristol, Dornier-Werke GmbH, Friedrichshafen, West Germany, and Matra, Toulouse.

Languages: English

NTIS Prices: PC A17/MF A01 Journal Announcement: GRAI8520; STAR2317

Country of Publication: Germany, Federal Republic of

Contract No.: ESA-5243/82/F-FC(SC)

European payload candidates which can be beneficially supported by a manned space station (MSS) are identified. The required operational space station support is assessed. Alternative approaches if no manned space station is available are discussed and the impact identified. The MSS is needed in life sciences, space technology, and materials science. The MSS need to be completed by free flying platforms for automatic material processes, space sciences, and Earth observations. The majority of identified payload candidates are for basic research. Commercial payloads are only identified in telecommunications. Identification of commercial materials processing payloads depends on the results from Spacelab.

Descriptors: \*European space programs; \*International cooperation; \*Manned orbital laboratories; \*Nasa programs; \*Orbital space stations; Space commercialization; Space processing; Spaceborne astronomy; Spaceborne experiments; Spacecraft design

Identifiers: \*Foreign technology; NTISNASAE

Section Headings: 22A (Space Technology--Astronautics); 84GE (Space Technology--General)

1140818 N85-27926/3/XAB

**European Utilization Aspects of a US Manned Space Station. Volume 1**

(Final rept)

Deutsche Forschungs- und Versuchsanstalt fuer Luft- und Raumfahrt e.V., Cologne (Germany, F.R.).

Corp. Source Codes: 062739000; D0696939

Sponsor: National Aeronautics and Space Administration, Washington, DC.

Report No.: ESA-CR(P)-1987-V-1

Apr 83 65p

Prepared in Cooperation with Mbb GmbH, Bremen, West Germany, (cont. next page)

ORIGINAL PAGE IS  
OF POOR QUALITY

## DIALOG File 6: NTIS - 64-86/ISS11 (Copr. NTIS)

Aeritalia Spa, Turin, British Aerospace Aircraft Group, Bristol, Dornier-Werke GmbH, Friedrichshafen, West Germany, and Matra, Toulouse.

Languages: English

NTIS Prices: PC A04/MF A01 Journal Announcement: GRAI8520; STAR2317

Country of Publication: Germany, Federal Republic of

Contract No.: ESA-5243/82/F-FC(SC)

European payload candidates which can be beneficially supported by a manned space station (MSS) are identified. The required operational station support is assessed. Alternative approaches if no manned space station is available are discussed and the impact identified. The MSS is needed in life sciences, space technology, and materials science. The MSS needs to be completed by free flying platforms for automatic material processes, space sciences, and Earth observations. The majority of identified payload candidates are for basic research. Commercial payloads are only identified in telecommunications. Identification of commercial materials processing payloads depends on the results from Spacelab.

Descriptors: \*European space programs; \*International cooperation; \*Manned orbital laboratories; \*Nasa programs; \*Orbital space stations; Space commercialization; Space processing; Spaceborne astronomy; Spaceborne experiments; Spacecraft design

Identifiers: \*Foreign technology; NTISNASAE

Section Headings: 22A (Space Technology--Astronautics); 84GE (Space Technology--General)

1124977 N85-21187/8/XAB

**Monodisperse Latex Reactor (MLR): A Materials Processing Space Shuttle Mid-Deck Payload**

Kornfeld, D. M.

National Aeronautics and Space Administration, Huntsville, AL, George C. Marshall Space Flight Center.

Corp. Source Codes: O19043002; ND736801

Report No.: NAS 1.15:86487; NASA-TM-86487

Jan 85 16p

Languages: English

NTIS Prices: PC A02/MF A01 Journal Announcement: GRAI8514; STAR2312

Country of Publication: United States

The monodisperse latex reactor experiment has flown five times on the space shuttle, with three more flights currently planned. The objectives of this project is to manufacture, in the microgravity environment of space, large particle-size monodisperse polystyrene latexes in particle sizes larger and more uniform than can be manufactured on Earth. Historically it has been extremely difficult, if not impossible to manufacture in quantity very high quality monodisperse latexes on Earth in particle sizes much above several micrometers in diameter due to buoyancy and sedimentation problems during the polymerization reaction. However the MLR project has succeeded in manufacturing in microgravity monodisperse latex particles as large as 30 micrometers in diameter with a standard deviation of 1.4 percent. It is expected that 100 micrometer

particles will have been produced by the completion of the the three remaining flights. These tiny, highly uniform latex microspheres have become the first material to be commercially marketed that was manufactured in space.

Descriptors: \*Chemical reactors; \*Latex; \*Microgravity applications; \*Microparticles; \*Polystyrene; \*Space processing; \*Space shuttle payloads; Particle size distribution; Polymerization; Space commercialization; Spheres

Identifiers: NTISNASA

Section Headings: 11I (Materials--Plastics); 22B (Space Technology--Spacecraft); 7A (Chemistry--Chemical Engineering) 710 (Materials Sciences--Plastics); 84GE (Space Technology--General); 99B (Chemistry--Industrial Chemistry and Chemical Process Engineering)

1122865 N85-18993/4/XAB

**Commerce Lab: Mission Analysis and Payload Integration Study (Interim progress rept)**

Wyle Labs., Inc., Huntsville, AL.

Corp. Source Codes: O18042000; W9307657

Sponsor: National Aeronautics and Space Administration, Washington, DC.

Report No.: NAS 1.26:174381; NASA-CR-174381

6 Dec 84 87p

Languages: English

NTIS Prices: PC A05/MF A01 Journal Announcement: GRAI8513; STAR2310

Country of Publication: United States

Contract No.: NAS8-36109

Conceived as one or more arrays of carriers which would fly aboard space shuttle, Commerce Lab can provide a point of focus for implementing a series of shuttle flights, co-sponsored by NASA and U.S. domestic concerns, for performing materials processing in research and pre-commercial investigations. As an orbiting facility for testing, developing, and implementing hardware and procedures, Commerce Lab can enhance space station development and hasten space platform production capability. Tasks considered include: (1) synthesis of user requirements and identification of common element and voids; (2) definition of performance and infrastructure requirement and alternative approaches; and (3) carrier, mission model, and infrastructure development.

Descriptors: \*Reduced gravity; \*Space commercialization; \*Space laboratories; \*Space processing; \*Space shuttle payloads; User requirements; Government/industry relations; Interfaces; Mission planning; Payload integration plan; Spaceborne experiments; Tradeoffs

Identifiers: NTISNASA

Section Headings: 22A (Space Technology--Astronautics); 84A (Space Technology--Astronautics)

## DIALOG File 6: NTIS - 64-86/ISS11 (Copr. NTIS)

1106281 N85-11011/2/XAB

**Second Symposium on Space Industrialization**

Jernigan, C. M.

National Aeronautics and Space Administration, Huntsville,

AL. George C. Marshall Space Flight Center.

Corp. Source Codes: 019043002; ND736801

Report No.: NAS 1.55:2313; M-464; NASA-CP-2313

Oct 84 427p

Sponsored in Cooperation with Aiaa and Alabama Univ. Symp.  
Held in Huntsville, Ala., 13-15 Feb. 1984.

Languages: English Document Type: Conference proceeding

NTIS Prices: PC A19/MF A01 Journal Announcement: GRAI8504;

STAR2302

Country of Publication: United States

No abstract available.

Descriptors: \*Bioprocessing; \*Communication; \*Conferences;  
\*Economic factors; \*Government/Industry relations; \*Launch  
vehicles; \*Law (Jurisprudence); \*Policies; \*Reduced gravity;  
\*Remote sensing; \*Space commercialization; \*Space  
industrialization; \*Space processing; \*Space stations;  
Agriculture; Budgets; Crystal growth; Drop towers;  
Electrophoresis; Eureka (Esa); European space agency; Gallium  
arsenides; Glass; Iron; Landsat satellites; Latex; Manned  
orbital research laboratories; Nasa programs; Satellite  
imagery; Solidification; Space manufacturing; Space platforms  
Space shuttle payloads; Spacecraft maintenance; Technology  
assessment; Technology utilization

Identifiers: NTISNASA

Section Headings: 22A (Space Technology--Astronautics); 84GE  
(Space Technology--General)

1073490 N84-25776/5

**Opportunities for the Chemical Industry in Space, Part 1**

(Final Report)

Young (Edmond) and Associates, Mickleton, NJ.

Corp. Source Codes: 081424000; Y3117632

Sponsor: National Aeronautics and Space Administration,  
Washington, DC.

Report No.: NAS 1.26:173594; NASA-CR-173594

Feb 84 101p

Languages: English

NTIS Prices: PC A06/MF A01 Journal Announcement: GRAI8420;

STAR2216

Country of Publication: United States

Contract No.: NASW-3826

The chemical/petrochemical industry devotes a large  
percentage of its gross income to research and development,  
with much of its R and D of a long-term nature. As the  
chemical industry is examined as a candidate for space  
investigations, it is readily apparent that research and  
development in the space environment may lead to attractive  
commercial opportunities. The advantages of low gravity  
manufacturing, with a particular emphasis on chemical  
catalysts, are presented herein specifically for the chemical  
industry. Research from the Skylab program and Apollo Soyuz  
test project is reviewed, including acoustic levitation,

crystal growth, and container less melts. Space processing of  
composite materials, alloys, and coatings is also discussed.

Descriptors: \*Catalysts; \*Industries; \*Low gravity  
manufacturing; \*Metallurgy; \*Space commercialization; \*Space  
processing; Acoustic levitation; Alloys; Apollo soyuz test  
project; Coatings; Composite materials; Containerless melts;  
Crystal growth; Promotion; Public relations; Skylab program;  
Spacelab

Identifiers: NTISNASA

Section Headings: 7A (Chemistry--Chemical Engineering); 99B  
(Chemistry--Industrial Chemistry and Chemical Process  
Engineering); 84GE (Space Technology--General); 71GE  
(Materials Sciences--General)

1058563 N84-21437/8

**Alternative Strategies for Space Station Financing**

Walklet, D. C.; Heenan, A. T.

Terra-Mar, Mountain View, CA.

Corp. Source Codes: 080736000; T0425679

Sponsor: National Aeronautics and Space Administration,  
Washington, DC.

Report No.: NAS 1.26:175412; NASA-CR-175412

1 Sep 83 33p

Languages: English

NTIS Prices: PC A03/MF A01 Journal Announcement: GRAI8414;

STAR2211

Country of Publication: United States

Contract No.: NASW-3750

The attributes of the proposed space station program are  
oriented toward research activities and technologies which  
generate long term benefits for mankind. Unless such  
technologies are deemed of national interest and thus are  
government funded, they must stand on their own in the market  
place. Therefore, the objectives of a United States space  
station should be based on commercial criteria; otherwise,  
such a project attracts no long term funding. There is  
encouraging evidence that some potential space station  
activities should generate revenues from shuttle related  
projects within the decade. Materials processing concepts as  
well as remote sensing indicate substantial potential.  
Furthermore, the economics and thus the commercial feasibility  
of such projects will be improved by the operating  
efficiencies available with an ongoing space station program.

Descriptors: \*Financial management; \*Space commercialization  
; \*Space shuttle payloads; \*Space stations; Cost effectiveness  
; Economic analysis; Marketing; Remote sensing; Research and  
development; User requirements

Identifiers: NTISNASA

Section Headings: 22B (Space Technology--Spacecraft); 22A  
(Space Technology--Astronautics); 5C (Behavioral and Social  
Sciences--Economics); 84C (Space Technology--Manned  
Spacecraft); 84A (Space Technology--Astronautics); 70E  
(Administration and Management--Research Program  
Administration and Technology Transfer)

ORIGINAL PAGE IS  
OF POOR QUALITY

## DIALOG File 6: NTIS - 64-86/ISS11 (Copr. NTIS)

1006525 N83-28050/3

**User Requirements for the Commercialization of Space**  
(Final Report)Ecosystems International, Inc., Gambrills, MD.  
Corp. Source Codes: 056160000; ED819454Sponsor: National Aeronautics and Space Administration,  
Washington, DC.

Report No.: NAS 1.26:172762; NASA-CR-172762

May 83 138p

Languages: English

NTIS Prices: PC A07/MF A01 Journal Announcement: GRAI8323;

STAR2117

Country of Publication: United States

Contract No.: NASW-3674

The results of investigations of materials processing in  
space (MPS), space experimentation apparatus, and potential  
industrial users of MPS commercialization are discussed.Descriptors: \*Space industrialization; \*Space processing;  
\*User requirements; Crystal growth; Electrical resistivity;  
Germanium

Identifiers: NTISNASA

Section Headings: 22B (Space Technology--Spacecraft); 84GE  
(Space Technology--General)

953469 N83-11158/3

**Space Fabrication Demonstration System Composite Beam Cap  
Fabricator**

(Final Report)

Grumman Aerospace Corp., Bethpage, NY.

Corp. Source Codes: 029609000; G6919090

Sponsor: National Aeronautics and Space Administration,  
Washington, DC.

Report No.: NAS 1.26:170642; NASA-CR-170642

Mar 82 67p

Languages: English

NTIS Prices: PC A04/MF A01 Journal Announcement: GRAI8307;

STAR2102

Country of Publication: United States

Contract No.: NAS8-32472

A detailed design for a prototype, composite beam cap  
fabricator was established. Inputs to this design included  
functional tests and system operating requirements. All  
required materials were procured, detail parts were  
fabricated, and one composite beam cap forming machine was  
assembled. The machine was demonstrated as a stand-alone  
system. Two 12-foot-long beam cap members were fabricated from  
laminates graphite/polysulfane or an equivalent material. One  
of these members, which was structurally tested in axial  
compression, failed at 490 pounds.Descriptors: \*Fabrication; \*Fiber composites; \*Rectangular  
beams; \*Resin matrix composites; \*Roll forming; \*Space  
manufacturing; \*Trusses; Automatic control; Axial compression  
loads; Control equipment; Heating equipment; Laminates; Load  
tests; Microprocessors; Space shuttle payloads; Thermoplastic  
resins

Identifiers: NTISNASA

Section Headings: 22A (Space Technology--Astronautics); 13H  
(Mechanical, Industrial, Civil, and Marine Engineering--Indus-  
trial Processes); 84GE (Space Technology--General); 94G  
(Industrial and Mechanical Engineering--Manufacturing  
Processes and Materials Handling)

907230 N82-19236/0

**Manufacturing in Space: Fluid Dynamics Numerical Analysis**

(Annual Report, Aug. 1980 - Aug. 1981)

Robertson, S. J.; Nicholson, L. A.; Spradley, L. W.

Lockheed Missiles and Space Co., Inc., Huntsville, AL.

Corp. Source Codes: 062511000; L1340457

Sponsor: National Aeronautics and Space Administration,  
Washington, DC.

Report No.: NASA-CR-168610; LMSC-HREC-TR-D784480

Aug 81 51p

Languages: English

NTIS Prices: PC A04/MF A01 Journal Announcement: GRAI8215;

STAR2010

Country of Publication: United States

Contract No.: NASW-3281

Natural convection in a spherical container with cooling at  
the center was numerically simulated using the  
Lockheed-developed General Interpolants Method (GIM) numerical  
fluid dynamic computer program. The numerical analysis was  
simplified by assuming axisymmetric flow in the spherical  
container, with the symmetry axis being a sphere diagonal  
parallel to the gravity vector. This axisymmetric spherical  
geometry was intended as an idealization of the proposed  
Lal/Kroes growing experiments to be performed on board  
Spacelab. Results were obtained for a range of Rayleigh  
numbers from 25 to 10,000. For a temperature difference of 10  
C from the cooling sting at the center to the container  
surface, and a gravitational loading of 0.000001 g a computed  
maximum fluid velocity of about  $2.4 \times 0.00001$  cm/sec was  
reached after about 250 sec. The computed velocities were  
found to be approximately proportional to the Rayleigh number  
over the range of Rayleigh numbers investigated.Descriptors: \*Computational fluid dynamics; \*Computer  
programs; \*Computerized simulation; \*Crystal growth; \*Space  
manufacturing; Axisymmetric flow; Circular cylinders;  
Convection; Cooling; Flow velocity; Gravitation; Rayleigh  
number; Spacelab

Identifiers: NTISNASA

Section Headings: 22A (Space Technology--Astronautics); 9B  
(Electronics and Electrical Engineering--Computers); 22B  
(Space Technology--Spacecraft); 84A (Space Technology--Astron-  
autics); 84C (Space Technology--Manned Spacecraft)

893984 N82-15093/9

**Investigations on the Influence of Gravity on Joining  
Processes with Liquid Melts, and of Brazing and Welding  
Experiments under Weightlessness**

(cont. next page)

**DIALOG File 6: NTIS - 64-86/ISS11 (Copr. NTIS)**

(Final Report, Jul. 1980)  
 Hoffmeister, H. ; Ruediger, J.  
 Hochschule der Bundeswehr, Hamburg (Germany, F.R.). Lab.  
 fuer Werkstoffkunde und Schweissttechnik.  
 Corp. Source Codes: 074758001; HV208010  
 Sponsor: National Aeronautics and Space Administration,  
 Washington, DC.  
 Report No.: BMFT-FB-W-81-024; ISSN-0170-1339  
 Jun 81 94p  
 In German; English Summary. Sponsored by Bundesministerium  
 fuer Forschung und Technologie.  
 Languages: German  
 NTIS Prices: PC A05/MF A01 Journal Announcement: GRAI8210;  
 STAR2006

Country of Publication: Germany, Federal Republic of  
 Physical mechanisms in welding and brazing likely to be  
 affected by space conditions are considered and the literature  
 on actual space experiments is reviewed. Proposed Spacelab  
 test experiments and complementary testing on Earth are  
 described. Further development needs are identified in arc  
 welding. It is proposed to analyze the influence of gravity on  
 material transfer, on the shape and structure of seam, and on  
 the segregation of the phases by: (1) taking advantage of  
 rotary motions on Earth in order to raise the g level or to  
 create short time weightlessness; (2) working in an aircraft  
 or rocket under longer microgravity conditions; and (3)  
 performing arc-spot welding in a vacuum so as to develop this  
 process for use in space.

Descriptors: \*Brazing; \*Fusion welding; \*Space manufacturing  
 ; \*Spaceborne experiments; \*Spacelab; \*Weightlessness; Liquid  
 metals; Solidification; Weightlessness simulation; Weld tests  
 Wettability

Identifiers: \*Foreign technology; NTISNASAE  
 Section Headings: 22A (Space Technology--Astronautics); 13H  
 (Mechanical, Industrial, Civil, and Marine Engineering--Indus-  
 trial Processes); 94G (Industrial and Mechanical  
 Engineering--Manufacturing Processes and Materials Handling);  
 84GE (Space Technology--General)

793461 N80-28404/5

**Space Processing Application Rocket Project, SPAR 5**  
 (Final Report)  
 Reeves, F. ; Schaefer, D.  
 National Aeronautics and Space Administration, Huntsville,  
 AL. George C. Marshall Space Flight Center.  
 Corp. Source Codes: 019043002; ND736801  
 Report No.: NASA-TM-78275  
 Aug 80 271p  
 Languages: English  
 NTIS Prices: PC A12/MF A01 Journal Announcement: GRAI8024;  
 STAR1819

Country of Publication: United States  
 Post flight results and analysis are presented on the  
 following experiments: 'Agglomeration in Immiscible Liquids',  
 'Contained Polycrystalline Solidification in Low G', 'The  
 Direct Observation of Dendrite Remelting and Macroseggregation

in Casting', and 'Uniform Dispersion by Crystallization'. An  
 engineering report on the performance of the SPAR Black Brant  
 rocket is also included. Much useful data and information were  
 accumulated for directing and developing experimental  
 techniques and investigations toward an expanding commercially  
 beneficial program of materials processing in the coming  
 shuttle era.

Descriptors: \*Black brant sounding rockets; \*Dendritic  
 crystals; \*Liquids; \*Polycrystals; \*Space manufacturing;  
 \*Space processing applications rocket; Low gravity  
 manufacturing; Melting; Production management; Solubility

Identifiers: NTISNASA  
 Section Headings: 22A (Space Technology--Astronautics); 13H  
 (Mechanical, Industrial, Civil, and Marine Engineering--Indus-  
 trial Processes); 84GE (Space Technology--General); 94G  
 (Industrial and Mechanical Engineering--Manufacturing  
 Processes and Materials Handling)

746185 N80-11112/3

**Evaluation Criteria for Commercially Oriented Materials  
 Processing in Space Proposals**  
 (Final Report)

Moore, W. F. ; Mcdowell, J. R.  
 Battelle Columbus Labs., Ohio.  
 Report No.: NASA-CR-162437; BCL-OA-TFR-78-5  
 Jan 79 58p  
 Languages: English  
 NTIS Prices: PC A04/MF A01 Journal Announcement: GRAI8005;  
 STAR1802

Country of Publication: United States  
 Contract No.: NASW-2800  
 An approach and criteria for evaluating NASA funded  
 experiments and demonstrations which have commercial potential  
 were developed. Methods for insuring quick initial screening  
 of commercial proposals are presented. Recommendations are  
 given for modifying the current evaluation approach. New  
 criteria for evaluating commercially orientated materials  
 processing in space (MPS) proposals are introduced. The  
 process for selection of qualified individuals to evaluate the  
 phases of this approach and criteria is considered and  
 guidelines are set for its implementation.

Descriptors: \*Management planning; \*Space manufacturing;  
 \*Spaceborne experiments; Commerce; Industries; Market research  
 ; Technology utilization

Identifiers: NTISNASA  
 Section Headings: 22A (Space Technology--Astronautics); 13H  
 (Mechanical, Industrial, Civil, and Marine Engineering--Indus-  
 trial Processes); 84GE (Space Technology--General); 94G  
 (Industrial and Mechanical Engineering--Manufacturing  
 Processes and Materials Handling)

## DIALOG File 6: NTIS - 64-88/ISS11 (Copr. NTIS)

744199 N80-10268/4

**Feasibility of Commercial Space Manufacturing, Production of Pharmaceuticals. Volume 3: Product Data**

(Final Report)

McDonnell-Douglas Astronautics Co., St. Louis, Mo.

Report No.: NASA-CR-161326; MDC-E2104-V-3

9 Nov 78 191p

Languages: English

NTIS Prices: PC A09/MF A01 Journal Announcement: GRAI8004;

STAR1801

Country of Publication: United States

Contract No.: NAS8-31353

The feasibility of commercial manufacturing of pharmaceuticals in space is analyzed and the study results are presented. The chronology of the study process is discussed. The separation of serum proteins by the continuous flow electrophoresis process is investigated. The production requirements of twelve candidate products including antihemophilic factor, beta cells, erythropoietin, epidermal growth factor, alpha-1-antitrypsin, and interferon are evaluated.

Descriptors: \*Electrophoresis; \*Pharmacology; \*Space manufacturing; \*Space processing; Cells (Biology); Epidermis; Industries; Interferon; Research and development

Identifiers: \*Drugs; NTISNASA

Section Headings: 60 (Biological and Medical Sciences--Pharmacology); 22A (Space Technology--Astronautics) 57Q (Medicine and Biology--Pharmacology and Pharmacological Chemistry); 84GE (Space Technology--General)

744198 N80-10267/6

**Feasibility of Commercial Space Manufacturing, Production of Pharmaceuticals. Volume 2: Technical Analysis**

(Final Report)

McDonnell-Douglas Astronautics Co., St. Louis, Mo.

Report No.: NASA-CR-161325; MDC-E2104-V-2

9 Nov 78 37p

Languages: English

NTIS Prices: PC A03/MF A01 Journal Announcement: GRAI8004;

STAR1801

Country of Publication: United States

Contract No.: NAS8-31353

A technical analysis on the feasibility of commercial manufacturing of pharmaceuticals in space is presented. The method of obtaining pharmaceutical company involvement, laboratory results of the separation of serum proteins by the continuous flow electrophoresis process, the selection and study of candidate products, and their production requirements is described. The candidate products are antihemophilic factor, beta cells, erythropoietin, epidermal growth factor, alpha-1-antitrypsin and interferon. Production mass balances for antihemophilic factor, beta cells, and erythropoietin were compared for space versus ground operation. A conceptual description of a multiproduct processing system for space operation is discussed. Production requirements for epidermal growth factor of alpha-1-antitrypsin and interferon are

presented.

Descriptors: \*Electrophoresis; \*Pharmacology; \*Space manufacturing; \*Space processing; Cells (Biology); Epidermis; Industries; Interferon; Research and development

Identifiers: \*Drugs; NTISNASA

Section Headings: 60 (Biological and Medical Sciences--Pharmacology); 22A (Space Technology--Astronautics) 57Q (Medicine and Biology--Pharmacology and Pharmacological Chemistry); 84GE (Space Technology--General)

744197 N80-10266/8

**Feasibility of Commercial Space Manufacturing, Production of Pharmaceuticals. Volume 1: Executive Summary**

(Final Report)

McDonnell-Douglas Astronautics Co., St. Louis, Mo.

Report No.: NASA-CR-161324; MDC-E2104-V-1

9 Nov 78 228p

Languages: English

NTIS Prices: PC A11/MF A01 Journal Announcement: GRAI8004;

STAR1801

Country of Publication: United States

Contract No.: NAS8-31353

The feasibility of the commercial manufacturing of pharmaceuticals in space is examined. The method of obtaining pharmaceutical company involvement, laboratory results of the separation of serum proteins by the continuous flow electrophoresis process, the selection and study of candidate products, and their production requirements is presented. Antihemophilic factor, beta cells, erythropoietin, epidermal growth factor, alpha-1-antitrypsin and interferon were studied. Production mass balances for antihemophilic factor, beta cells, and erythropoietin were compared for space versus ground operation.

Descriptors: \*Electrophoresis; \*Pharmacology; \*Space manufacturing; \*Space processing; Cells (Biology); Epidermis; Industries; Interferon; Research and development

Identifiers: \*Drugs; NTISNASA

Section Headings: 60 (Biological and Medical Sciences--Pharmacology); 22A (Space Technology--Astronautics) 57Q (Medicine and Biology--Pharmacology and Pharmacological Chemistry); 84GE (Space Technology--General)

735511 NTIS/PS-79/1053/2

**Manufacturing in Space, 1976-79 (Citations from the International Aerospace Abstracts Data Base)**

(Rept. for 1976-Oct 79)

Zollars, Gerald F.

New Mexico Univ., Albuquerque. Technology Application Center.

Corp. Source Codes: 012614036

Sponsor: National Technical Information Service, Springfield, VA.

Oct 79 85p

(cont. next page)

**DIALOG File 6: NTIS - 64-86/ISS11 (Copr. NTIS)**

Sponsored in part by National Technical Information Service, Springfield, VA.

Languages: English Document Type: Bibliography

NTIS Prices: PC N01/MF N01 Journal Announcement: GRAI7926

The cited articles from worldwide literature concern manufacturing in space. Stressed are the effects of weightlessness on a variety of manufacturing processes such as crystal growth, welding, zone melting, casting, and the construction of structures. Articles concerning materials science research in the European Spacelab program are included. (Contains 331 citations).

Descriptors: \*Manufacturing; \*Bibliographies; Aerospace environments; Construction; Weightlessness; Processing; Abstracts

Identifiers: \*Space manufacturing; NTISNTIST

Section Headings: 13H (Mechanical, Industrial, Civil, and Marine Engineering--Industrial Processes); 22A (Space Technology--Astronautics); 84GE (Space Technology--General)

694045 N79-14118/0

**Review of Industry Interest in Space Processing**

(Final Report)

Mcdowell, J. R.

Battelle Columbus Labs., OH.

Report No.: NASA-CR-158026; BCL-OA-TFR-78-2

Apr 78 6p

Languages: English

NTIS Prices: PC A02/MF A01 Journal Announcement: GRAI7909; STAR1705

Contract No.: NASW-2800

The interest on the part of selected U.S. corporation in using the research facilities and capabilities for materials processing in space utilizing the Space Shuttle was assessed. The effectiveness of the interview techniques as a method for gaining insight into the complex array of issues related to materials processing in space was evaluated. The survey, conducted was intended as a random sample of individuals, representing industry, who were currently involved in materials processing in space.

Descriptors: \*Space processing; \*Space shuttles; Technology utilization; Materials handling; Random sampling; Research facilities; Surveys

Identifiers: Space manufacturing; Processing; NTISNASA

Section Headings: 22A (Space Technology--Astronautics); 13H (Mechanical, Industrial, Civil, and Marine Engineering--Industrial Processes); 84GE (Space Technology--General); 84A (Space Technology--Astronautics); 94G (Industrial and Mechanical Engineering--Manufacturing Processes and Materials Handling)

661818 N78-25103/0

**Descriptions of Experiments Selected for the Space Transportation System (STS) Materials Processing in Space Program**

Naumann, R. J.

National Aeronautics and Space Administration, Marshall

Space Flight Center, Huntsville, Ala.

Report No.: NASA-TM-78175

May 78 33p

NTIS Prices: PC A03/MF A01 Journal Announcement: GRAI7820; STAR1616

Summaries are presented for the first group of materials processing experiments planned for a shuttle mission. Outlined are the objectives, the approach, the rationale for the use of space, and the anticipated results for each experiment.

Descriptors: Experimentation; \*Materials; \*Space processing \*Space transportation system; Mission planning; Space manufacturing; Space programs; Space shuttles

Identifiers: \*Experimental design; NTISNASA

Section Headings: 22A (Space Technology--Astronautics); 84GE (Space Technology--General)

656490 N78-23115/6

**Space Processing Applications Bibliography**

National Aeronautics and Space Administration, Marshall Space Flight Center, Huntsville, Ala.

Report No.: NASA-TM-78167

Apr 78 180p

Document Type: Bibliography

NTIS Prices: PC A09/MF A01 Journal Announcement: GRAI7818; STAR1614

This special bibliography lists 724 articles, papers, and reports which discuss various aspects of the use of the space environment for materials science research or for commercial enterprise. The potentialities of space processing and the improved materials processes that are made possible by the unique aspects of the space environment are emphasized. References identified in April, 1978 are cited.

Descriptors: \*Bibliographies; \*Low gravity manufacturing; \*Space processing; Ceramics; Containerless melts; Electrophoresis; Solidification; Space industrialization; Space manufacturing

Identifiers: NTISNASA

Section Headings: 20L (Physics--Solid-state Physics); 22B (Space Technology--Spacecraft); 46D (Physics--Solid State Physics); 84GE (Space Technology--General); 71GE (Materials Sciences--General)

610044 N77-30142/2

**Improved Catalysts by Low-G Processing**

Grodzka, P. G. ; Picklesimer, E. A.

Lockheed Missiles and Space Co., Huntsville, Ala.

Report No.: NASA-CR-150377; LMSC-HREC-FR-DOB4883

Aug 77 85p

NTIS Prices: PC A05/MF A01 Journal Announcement: GRAI7726; STAR1521

Contract No.: NAS8-32352

The advantages of space for manufacturing more perfect microcrystalline morphologies and structures will be (cont. next page)

ORIGINAL PAGE IS  
OF POOR QUALITY



## DIALOG File 6: NTIS - 64-86/ISS11 (Copr. NTIS)

investigation. Production of smaller silver and palladium crystals with enhanced catalytic properties is discussed. The elimination of convection accompanying electrodeposition of fine metallic powders at high overvoltages in a low gravity environment is outlined.

Descriptors: \*Catalysis; \*Electrodeposition; Microcrystals; \*Reduced gravity; \*Space manufacturing; Metal coatings; Overvoltage; Palladium; Product development; Silver

Identifiers: \*Crystal growth; NTISNASA

Section Headings: 7D (Chemistry--Physical Chemistry); 20L (Physics--Solid-state Physics); 99F (Chemistry--Physical and Theoretical Chemistry); 46D (Physics--Solid State Physics); 84GE (Space Technology--General)

568630 PB-264 286/6

**NBS Space Processing Research**

(Annual rept. 1 Jan 76-31 Dec 76)

Passaglia, E.; Parker, R. L.

National Bureau of Standards, Washington, D.C. Inst. for Materials Research.

Corp. Source Codes: 401937

Sponsor: National Aeronautics and Space Administration, Huntsville, Ala. Marshall Space Flight Center.

Report No.: NBSIR-77-1208

Feb 77 116p

See also PB-250 849.

NTIS Prices: PC A06/MF A01 Journal Announcement: GRAI7711

Contract No.: NASA Order-H-19333B

The results obtained for each task are given in detailed summaries in the body of the report. Briefly, in Task 1 - Crystal Perfection in Czochralski Growth - large nickel single crystals have been grown having dislocation densities as low as 400 lines/sq cm as assessed by x-ray dynamical diffraction techniques. In Task 2 - Evaporative Purification of Ultra-High Purity Materials - Part A - it was determined that the use of sessile drops as a means of support for the study of molten alumina places severe restrictions on the type and validity of the data that can be obtained in view of temperature measurement and control problems encountered. In Part B, rates of evaporative purification were determined for Nb-Mo and for Mo-Zr alloys at elevated temperatures using R.F. levitation of molten drops. In Task 3 - Vapor Transport Synthesis and Crystal Growth - the growth of 1.5 cm diameter crystals of mercurous chloride crystals by a vapor Bridgman technique is described. In Task 4 - Melt Shape in Weightless Crystal Growth, thermocapillary forces on air bubbles in a viscous oil were measured, and the shape of axisymmetric liquid zones and their stability with respect to perturbations has been investigated numerically.

Descriptors: \*Aerospace environments; \*Crystal growth; \*Purification; \*Fabrication; Crystal defects; Czochralski process; Nickel; Single crystals; X ray diffraction; Aluminum oxide; Experimental design; Laboratory tests; Reduced gravity Evaporation; Vacuum; Drops; Convection; Transport properties; Molybdenum alloys; Niobium alloys; Zirconium alloys; Chlorides; Mercury inorganic compounds

Identifiers: \*Space processing; Space manufacturing; Bridgman growth technique; Mercury chlorides; NTISCOMNBS; NTISNASA

Section Headings: 20B (Physics--Crystallography); 11B (Materials--Ceramics, Refractories, and Glasses); 11F (Materials--Metallurgy and Metallography); 22A (Space Technology--Astronautics); 46D (Physics--Solid State Physics) 71GE (Materials Sciences--General); 84GE (Space Technology--General)

562103 N77-13094/6

**Possibilities for Industrial Material Production and Processing Techniques in Space from the Mechanical Engineering Point of View**

Hau, E.; Leven, P.

Maschinenfabrik Augsburg-Nuernberg A.G., Munich (West Germany). Neue Technologie.

Report No.: BMFT-FB-W-76-03

Apr 76 43p

In German; English Summary.

NTIS Prices: PC A03/MF A01 Journal Announcement: GRAI7709; STAR1504

Contract No.: BMFT-WRT-1074; GFW-RV-21-V-47/74

An investigation carried out within the GHH Engineering Group into possible industrial applications for Spacelab resulted in 22 proposals. Following more detailed discussion, 8 of these proposals were selected, and certain basic requirements for their industrial application in the near future are given. These proposals can be separated into two groups: industrial heat-treatment and casting techniques for highly stressed precision machine components (e.g. turbine blades) and production of nonmetallic composite materials. Before any definitive conclusions regarding the suitability of these proposals can be reached, more detailed technological feasibility studies are necessary.

Descriptors: Mechanical engineering; \*Space manufacturing; \*Spacelab; Carbon fibers; Casting; Composite materials; Heat treatment; Hot working; Industries; Production engineering; Reinforcing fibers; Turbine blades

Identifiers: West Germany; NTISNASAE

Section Headings: 22A (Space Technology--Astronautics); 22B (Space Technology--Spacecraft); 84C (Space Technology--Manned Spacecraft); 94G (Industrial and Mechanical Engineering--Manufacturing Processes and Materials Handling)

558502 N77-12083/0

**Manufacturing Unique Glasses in Space**

(Interim Report, 1 Nov. 1974 - 31 Mar. 1976)

Happe, R. P.

Rockwell International Corp., El Segundo, Calif. Space Div.

Report No.: NASA-CR-150067; SD-76-SA-0029

31 Mar 76 42p

NTIS Prices: PC A03/MF A01 Journal Announcement: GRAI7708; (cont. next page)

ORIGINAL PAGE IS  
OF POOR QUALITY

DIALOG File 6: NTIS - 64-86/ISS11 (Copr. NTIS)

STAR1503

Contract No.: NAS8-28991

An air suspension melting technique is described for making glasses from substances which to date have been observed only in the crystalline condition. A laminar flow vertical wind tunnel was constructed for suspending oxide melts that were melted using the energy from a carbon dioxide laser beam. By this method it is possible to melt many high-melting-point materials without interaction between the melt and crucible material. In addition, space melting permits cooling to suppress crystal growth. If a sufficient amount of under cooling is accompanied by a sufficient increase in viscosity, crystallization will be avoided entirely and glass will result. (Author)

Descriptors: Containerless melts; \*Glass; \*Oxides; \*Space manufacturing; Amorphous materials; Crystallization; Melting points; Supercooling

Identifiers: NTISNASA

Section Headings: 11B (Materials--Ceramics, Refractories, and Glasses); 22B (Space Technology--Spacecraft); 71D (Materials Sciences--Ceramics, Refractories, and Glass); 84GE (Space Technology--General)

## DIALOG File 6: NTIS - 64-86/ISS11 (Copr. NTIS)

521972 N76-26246/8

**Possibilities of Manufacturing, and of Scientific Research in the Space Environment, and Effective Realization Thereof (Literature Study) Studie ueber die Moeglichkeiten der Fertigung Bzw. Der Durchfuehrung von Wissenschaftlichen Untersuchungen Unter Weltraumbedingungen und ueber Deren Zweckmaessige Gestaltung (Literaturstudie)**

Beck, R. ; Gruenthaler, K. H. ; Gaar, H. ; Hums, D. ; Mueller, U.

Battelle Inst., Frankfurt am Main (West Germany).

Report No.: BMFT-FB-W-75-24

Dec 75 208p

In German; English Summary.

NTIS Prices: PC A10/MF A01 Journal Announcement: GRAI7622; STAR1417

Contract No.: BMFT-WRT-1073; GFW-RV-21-V-10/73

Ideas for carrying out space experiments in the fields of materials science and biology as well as the results of experiments conducted during the Apollo 14 and the Skylab missions are summarized. Available literature published up to February 1974 was studied. Important aspects are emphasized for planning future experiments in the fields of ceramics, metals and alloys, composites, single crystals, and biological processes for which space manufacturing appears to be particularly interesting. (Author)

Descriptors: +Aerospace environments; Research and development; +Space laboratories; +Space manufacturing; Summaries; Alloys; Apollo 14 flight; Ceramics; Composite materials; Electrophoresis; Glass; Literature; Metals; Single crystals; Skylab program

Identifiers: West Germany; NTISNASAE

Section Headings: 22A (Space Technology--Astronautics)

501600 N76-18199/9

**Space Transportation**

(Practical Applications of Space Systems)

National Academy of Sciences - National Research Council, Washington, D.C.

Report No.: NASA-CR-146277; PAPER-12

1975 40p

NTIS Prices: PC A03/MF A01 Journal Announcement: GRAI7613; STAR1409

Contract No.: NSR-09-012-06

User-oriented panels were formed to examine practical applications of information or services derived from earth orbiting satellites. Topics discussed include: weather and climate; uses of communication; land use planning; agriculture, forest, and range; inland water resources; retractable resources; environmental quality; marine and maritime uses; and materials processing in space. Emphasis was placed on the interface of the space transportation system (STS) with the applications envisioned by the user panels. User requirements were compared with expected STS capabilities in terms of availability, carrying payload to orbit, and estimated costs per launch. Conclusions and recommendations were reported.

Descriptors: +Earth resources program; +Space transportation; +Technology utilization; +User requirements; Decision-making; Economic factors; Land use; Management planning; Oceanography; Resources management; Space manufacturing; Weather forecasting

Identifiers: NTISNASA

Section Headings: 22A (Space Technology--Astronautics); 84A (Space Technology--Astronautics); 84G (Space Technology--Unmanned Spacecraft); 70E (Administration and Management--Research Program Administration and Technology Transfer)

501586 N76-18183/3

**Processing Eutectics in Space**

(Summary Report)

Douglas, F. C. ; Galasso, S. F.

United Technologies Research Center, East Hartford, Conn.

Report No.: NASA-CR-144196; R75-911721-10

Nov 75 72p

NTIS Prices: PC A04/MF A01 Journal Announcement: GRAI7613; STAR1409

Contract No.: NAS8-29669

The investigations of directional solidification have indicated the necessity of establishing a secure foundation in earth-based laboratory processing in order to properly assess low-gravity processing. Emphasis was placed on evaluating the regularity of microstructure of the rod-like eutectic Al-Al3Ni obtained under different conditions of growth involving the parameters of thermal gradient, solidification rate, and interfacial curvature. In the case of Al-Al3Ni, where the Al3Ni phase appears as facets rods, solidification rate was determined to be a controlling parameter. Zone melting of thin eutectic films showed that for films of the order of 10 to 20 micrometers thick, the extra surface energy appears to act to stabilize a regular microstructure. The results suggest that the role of low-gravity as provided in space-laboratory processing of materials is to be sought in the possibility of generating a higher thermal gradient in the solidifying ingot for a given power input-output arrangement than can be obtained under normal one-g processes. (Author)

Descriptors: +Eutectics; +Solidification; +Space manufacturing; Aluminum alloys; Microstructure; Nickel alloys Surface energy; Thin films

Identifiers: Space processing; NTISNASA

Section Headings: 22A (Space Technology--Astronautics); 13H (Mechanical, Industrial, Civil, and Marine Engineering--Industrial Processes); 84C (Space Technology--Manned Spacecraft); 94G (Industrial and Mechanical Engineering--Manufacturing Processes and Materials Handling)

501583 N76-18162/7

**Materials Processing in Space**

(Practical Applications of Space Systems)

National Academy of Sciences - National Research Council,

(cont. next page)

ORIGINAL PAGE IS  
OF POOR QUALITY

## DIALOG File 6: NTIS - 64-86/ISS11 (Copr.) NTIS)

Washington, D.C.

Report No.: NASA-CR-146274; PAPER-9  
1975 40pNTIS Prices: PC A03/MF A01 Journal Announcement: GRAI7613;  
STAR1409

Contract No.: NSR-09-012-106

The feasibility and possible advantages of processing materials in a nongravitational field are considered. Areas of investigation include biomedical applications, the processing of inorganic materials, and flight programs and funding.

Descriptors: \*Low gravity manufacturing; \*Space manufacturing; Biomedical data; Cost analysis; Gravitational effects; Inorganic materials; Mission planning; Payloads

Identifiers: Space processing; NTISNASA

Section Headings: 22A (Space Technology--Astronautics); 13H (Mechanical, Industrial, Civil, and Marine Engineering--Industrial Processes); 84C (Space Technology--Manned Spacecraft); 94G (Industrial and Mechanical Engineering--Manufacturing Processes and Materials Handling)

501581 N76-18160/1

**Space Processing of Crystalline Materials: A Study of Known Methods of Electrical Characterization of Semiconductors: Bibliography**

(Final Technical Report)

Castle, J. G.

Alabama Univ., Huntsville, Dept. of Physics.

Report No.: NASA-CR-144187

Jan 76 39p

Document Type: Bibliography

NTIS Prices: PC A03 Journal Announcement: GRAI7613; STAR1409

Contract No.: NAS8-30774

A selective bibliography is given on electrical characterization techniques for semiconductors. Emphasis is placed on noncontacting techniques for the standard electrical parameters for monitoring crystal growth in space, preferably in real time with high resolution. (Author)

Descriptors: \*Bibliographies; \*Semiconductors (Materials); \*Space manufacturing; Crystal growth; Gallium arsenides; High resolution; Silicon

Identifiers: Space processing; NTISNASA

Section Headings: 20L (Physics--Solid-state Physics); 22A (Space Technology--Astronautics); 46D (Physics--Solid State Physics); 84C (Space Technology--Manned Spacecraft)

499190 N76-17158/6

**Skylab Materials Processing Facility Experiment Developer's Report**

Parks, P. G.

National Aeronautics and Space Administration, Marshall Space Flight Center, Huntsville, Ala.

Report No.: NASA-TM-X-64977; ED-2002-1770

1 Jul 75 176p

Subm-Prepared in Cooperation with Martin Marietta Corp., Denver.

NTIS Prices: PC A09/MF A01 Journal Announcement: GRAI7612;  
STAR1408

Contract No.: NAS8-24000

The development of the Skylab M512 Materials Processing Facility is traced from the design of a portable, self-contained electron beam welding system for terrestrial applications to the highly complex experiment system ultimately developed for three Skylab missions. The M512 experiment facility was designed to support six in-space experiments intended to explore the advantages of manufacturing materials in the near-zero-gravity environment of Earth orbit. Detailed descriptions of the M512 facility and related experiment hardware are provided, with discussions of hardware verification and man-machine interfaces included. An analysis of the operation of the facility and experiments during the three Skylab missions is presented, including discussions of the hardware performance, anomalies, and data returned to earth. (Author)

Descriptors: \*Skylab program; \*Space manufacturing; \*Test facilities; Design analysis; Weightlessness

Identifiers: NTISNASA

Section Headings: 22A (Space Technology--Astronautics); 84A (Space Technology--Astronautics); 84C (Space Technology--Manned Spacecraft); 94G (Industrial and Mechanical Engineering--Manufacturing Processes and Materials Handling)

496979 N76-16956/4

**Space Processing of Crystalline Materials: A Study of Known Methods of Electrical Characterization of Semiconductors (Final Report)**

Castle, J. G.

Alabama Univ., Huntsville, Dept. of Physics.

Report No.: NASA-CR-144158

Jan 76 24p

NTIS Prices: PC A02/MF A01 Journal Announcement: GRAI7611;  
STAR1407

Contract No.: NAS8-30774

A literature survey is presented covering nondestructive methods of electrical characterization of semiconductors. A synopsis of each technique deals with the applicability of the techniques to various device parameters and to potential in-flight use before, during, and after growth experiments on space flights. It is concluded that the very recent surge in the commercial production of large scale integrated circuitry and other semiconductor arrays requiring uniformity on the scale of a few microns, involves nondestructive test procedures which could well be useful to NASA for in-flight use in space processing. (Author)

Descriptors: \*Crystal growth; \*Electrical properties; \*Semiconductors (Materials); \*Space manufacturing; Electrical resistivity; Integrated circuits; Low gravity manufacturing; Nondestructive tests

Identifiers: NTISNASA

Section Headings: 20L (Physics--Solid-state Physics); 46D (cont. next page)

ORIGINAL PAGE IS  
OF POOR QUALITY

## DIALOG File 6: NTIS - 64-86/ISS11 (Copr. NTIS)

(Physics--Solid State Physics)

496771 N76-16122/3

**Study of Growth of Single Crystal Ribbon in Space**

(Final Report, 3 Sep. 1974 - 23 Oct. 1975)

Wood, V. E. ; Markworth, A. J.

Battelle Columbus Labs., Ohio.

Report No.: NASA-CR-144135

30 Oct 75 107p

NTIS Prices: PC A06/MF A01 Journal Announcement: GRAI7611;

STAR1407

Contract No.: NAS8-31007

The technical feasibility is studied of growing single-crystal silicon ribbon in the space environment. Procedures are described for calculating the electromagnetic fields produced in a silicon ribbon by an rf shaping coil. The forces on the ribbon and the degree of shaping to be expected are determined. The expected steady-state temperature distribution in the ribbon is calculated in the one-dimensional approximation. Calculations on simplified models indicate, that lack of flatness of the shaped ribbon and excessive heating of the melt by the eddy currents induced by the shaping fields may pose problems. An analysis of the relative effects of various kinds of forces other than electromagnetic showed that in the space environment capillarity forces would dominate, and that the shape of the melt is thus principally determined by the shape of any solids with which it comes in contact. This suggests that ribbon may be produced simply by drawing between parallel wires. A concept is developed for a process of off-angle growth, in which the ribbon is pulled at an angle to the solidification front. Such a process promises to offer increased growth rate, better homogeneity, and thinner ribbon. (Author)

Descriptors: \*Crystal growth; \*Ribbons; \*Single crystals; \*Space manufacturing; Aerospace environments; Electromagnetic fields; Feasibility analysis; Silicon; Temperature distribution

Identifiers: NTISNASA

Section Headings: 20B (Physics--Crystallography); 46D (Physics--Solid State Physics)

489998 N76-13934/4

**A Method and Apparatus for Continuously Processing a Single Crystalline Ribbon in a Reduced Gravity Environment**

(Patent Application)

Walter, H. U.

National Aeronautics and Space Administration. Marshall Space Flight Center, Huntsville, Ala.

Report No.: PAT-APPL-630 584; NASA-CASE-MFS-23002-1

Filed 10 Nov 75 14p

Subm-Sponsored by NASA.

Government-owned invention available for licensing. Copy of application available NTIS.

Document Type: Patent

NTIS Prices: PC A02/MF A01 Journal Announcement: GRAI7608;

STAR1404

A method and apparatus is described for continuously

producing an uncontaminated single crystalline sheet of material of a controlled thickness having substantially optically flat surfaces. The method is performed in a reduced gravitational environment, such as outer space. A polycrystalline sheet of material is fed through a chamber with a heating element which progressively melts a transverse strip of the material as it is moved through the chamber. A single crystalline seed is positioned closely adjacent the molten zone for transforming the polycrystalline material into a single crystalline foil. The heating element has curved ends and terminates short of the opposed edges of the polycrystalline sheet.

Descriptors: \*Low gravity manufacturing; \*Ribbons; \*Single crystals; Heat treatment; \*Patent applications; Space manufacturing; Surface properties

Identifiers: NTISNASA

Section Headings: 20B (Physics--Crystallography); 90GE (Government Inventions For Licensing--General); 46D (Physics--Solid State Physics); 94G (Industrial and Mechanical Engineering--Manufacturing Processes and Materials Handling)

487462 N76-11191/3

**Furnace and Support Equipment for Space Processing**

(Final Report)

Mazelsky, R. ; Duncan, C. S. ; Seidensticker, R. G. ; Johnson, R. A. ; Hopkins, R. H.

Westinghouse Research Labs., Pittsburgh, Pa.

Report No.: NASA-CR-144027

Feb 75 66p

NTIS Prices: PC A04/MF A01 Journal Announcement: GRAI7607;

STAR1402

Contract No.: NAS8-30289

A core facility capable of performing a majority of materials processing experiments is discussed. Experiment classes are described, the needs peculiar to each experiment type are outlined, and projected facility requirements to perform the experiments are treated. Control equipment (automatic control) and variations of the Czochralski method for use in space are discussed. (Author)

Descriptors: \*Czochralski method; \*Furnaces; \*Space manufacturing; \*Technology assessment; Automatic control; Containerless melts; Crystallization; Experimentation; Laboratory equipment; Space missions

Identifiers: NTISNASA

Section Headings: 22A (Space Technology--Astronautics); 84A (Space Technology--Astronautics); 84C (Space Technology--Manned Spacecraft)

480116 N76-10165/8

**Research on Metal Solidification in Zero-G State**

(Final Report, 15 May 1973 - 30 Jul. 1975)

Papazian, J. M. ; Larson, Jr., D. J.

Grumman Aerospace Corp., Bethpage, N.Y. Research Dept.

(cont. next page)

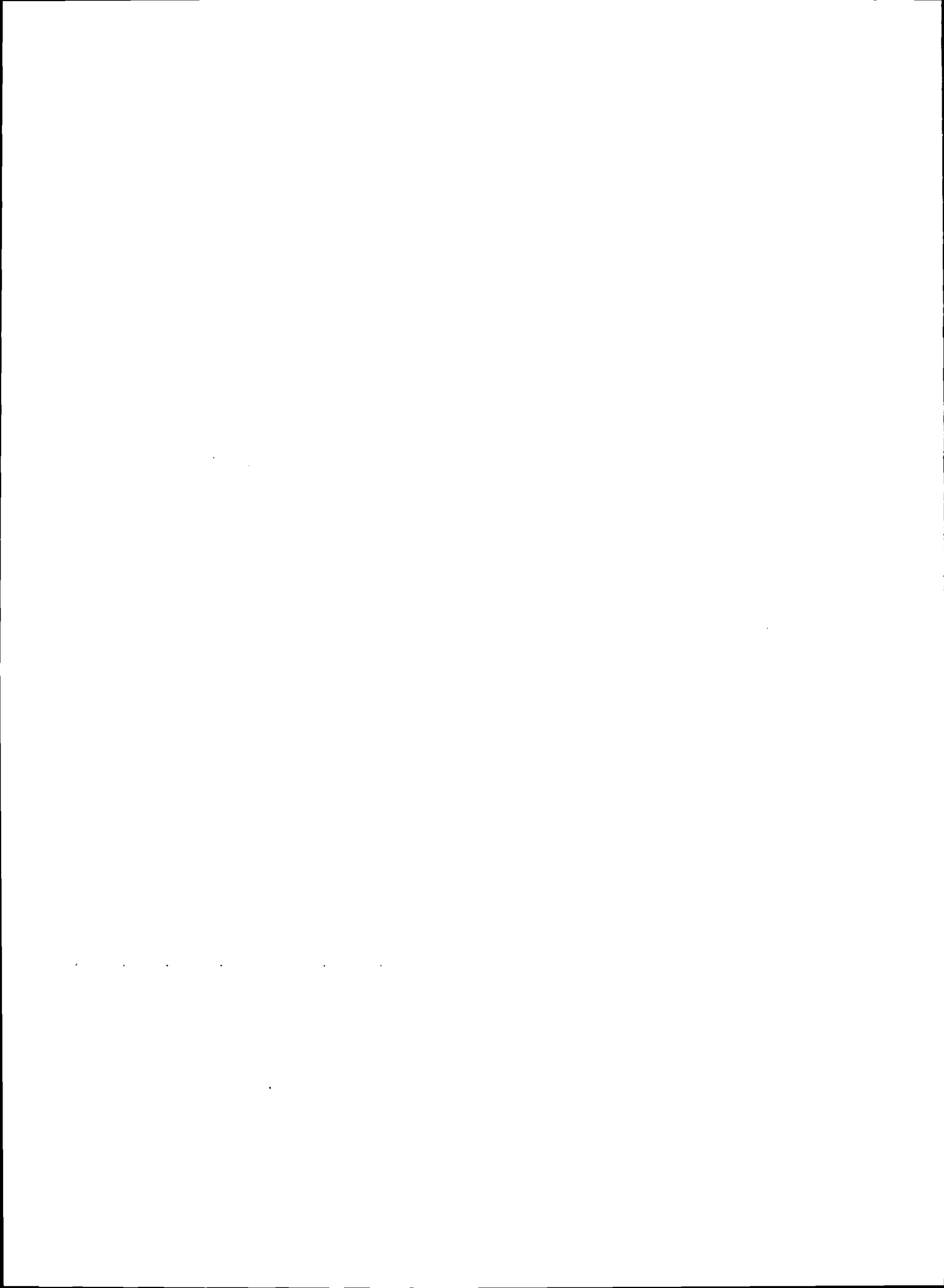

## DIALOG File 6: NTIS - 64-86/ISS11 (Copr. NTIS)

Report No.: NASA-CR-144013; RE-505  
30 Jul 75 76p

NTIS Prices: PC A05/MF A01 Journal Announcement: GRAI7603;  
STAR1401

Contract No.: NAS8-28604

The containerless solidification of several pure metals and metallic alloys was studied in a low gravity environment. The tests were performed in the MSFC 4.2 s drop tower using a rapid wire melting apparatus designed and built for this purpose. Pure iron and nickel, and alloys of iron-nickel, iron-carbon, nickel-aluminum and tungsten-rhenium were all melted and solidified at a gravity level of approximately 100.000/-4 g. Interpretation of the results has led to an appreciation of the factors controlling the successful execution of this drop test experiment and to a delineation of the limits of applicability of the apparatus. Preliminary metallurgical evaluations are presented of the overall shapes, lattice parameters, surface microstructure, cross-sectional microstructures, solidification and transformation sequences, evaporative segregation, and localized solute redistribution observed in the low-gravity specimens. The effects of low gravity on metallic solidification are discussed with particular emphasis on observations of spontaneous undercooling and evaporative segregation in uncontained melts. (Author)

Descriptors: \*Containerless melts; \*Solidification; \*Weightlessness; Aluminum alloys; Carbon; Crystal lattices; Iron alloys; Low gravity manufacturing; Microstructure; Nickel alloys; Phase transformations; Space manufacturing

Identifiers: NTISNASA

Section Headings: 11F (Materials--Metallurgy and Metallography); 94G (Industrial and Mechanical Engineering--Manufacturing Processes and Materials Handling)

477897 N75-33137/1

### Segregation Effects During Solidification in Weightless Melts

(Final Report)

Li, C.

Grumman Aerospace Corp., Bethpage, N.Y. Research Dept.

Report No.: NASA-CR-143981; RE-507

Jul 75 164p

NTIS Prices: PC A08/MF A01 Journal Announcement: GRAI7602;  
STAR1324

Contract No.: NAS8-29662

Computer programs are developed and used in the study of the combined effects of evaporation and solidification in space processing. The temperature and solute concentration profiles during directional solidification of binary alloys with surface evaporation were mathematically formulated. Computer results are included along with an econotechnical model of crystal growth. This model allows: prediction of crystal size, quality, and cost; systematic selection of the best growth equipment or alloy system; optimization of growth or material parameters; and a maximization of zero-gravity effects. Segregation in GaAs crystals was examined along with vibration

effects on GaAs crystal growth. It was found that a unique segregation pattern and strong convection currents exist in GaAs crystal growth. Some beneficial effects from vibration during GaAs growth were discovered. The implications of the results in space processing are indicated. (Author)

Descriptors: \*Crystallization; \*Evaporation; \*Solidification; \*Space manufacturing; \*Weightlessness; Computer programs; Crystal growth; Gallium arsenides; Prediction analysis techniques; Single crystals

Identifiers: NTISNASA

Section Headings: 22A (Space Technology--Astronautics); 20B (Physics--Crystallography); 84GE (Space Technology--General); 46D (Physics--Solid State Physics)

477895 N75-33127/2

### Economic Analysis of Materials Processing in Space

(Final Report, Mar. 1974 - Jun. 1975)

Vachon, R. I. ; Wilcox, R. C. ; Lacy, A. W. ; Hale, C. W. ; Beckett, S. D.

Auburn Univ., Ala. Engineering Experiment Station.

Report No.: NASA-CR-143965

15 Jun 75 265p

NTIS Prices: PC A12/MF A01 Journal Announcement: GRAI7602;  
STAR1324

Contract No.: NAS8-29881

The cost benefits and the feasibility of processing turbine blades, electrophoresis, and crystals in space were studied. signaling strategy. Then a min-H algorithm based on the FSM minimum principle is presented. This algorithm converges, after a finite number of steps, to a person - by - person extremal solution.

Descriptors: \*Economic analysis; \*Space manufacturing; Cost analysis; Crystal growth; Electrophoresis; Feasibility analysis; Space shuttles; Turbine blades

Identifiers: NTISNASA

Section Headings: 22A (Space Technology--Astronautics); 84A (Space Technology--Astronautics); 84C (Space Technology--Manned Spacecraft)

477890 N75-33085/2

### Bibliography of the Space Processing Program. Volume 1: A Compilation Through June 1974, Parts 1 and 2

Shultz, M. B. ; McClurken, Jr., E. W.

Universities Space Research Association, Charlottesville, Va.

Report No.: NASA-CR-143985

Oct 75 653p

Document Type: Bibliography

NTIS Prices: PC A99 Journal Announcement: GRAI7602; STAR1324

Contract No.: NAS8-31349; NGR-47-102-003

A compilation of NASA research efforts in the area of space environmental effects on materials and processes is presented. Topics considered are: (1) fluid mechanics and heat transfer;

(cont. next page)

## DIALOG File 6: NTIS - 64-86/ISS11 (Copr. NTIS)

(2) crystal growth and containerless melts; (3) acoustics; (4) glass and ceramics; (5) electrophoresis; (6) welding; and (7) exobiology.

Descriptors: \*Aerospace environments; \*Bibliographies; \*Space glossaries; \*Space manufacturing; \*Space programs; \*Spacecraft construction materials; Abstracts; Acoustics; Ceramics; Containerless melts; Contracts; Crystal growth; Electrophoresis; Exobiology; Fluid mechanics; Research projects; Space shuttles; Weightlessness; Welding

Identifiers: NTISNASA

Section Headings: 22A (Space Technology--Astronautics); 84A (Space Technology--Astronautics); 84C (Space Technology--Manned Spacecraft)

466327 N75-27081/9

**Space Processing of Composite Materials**

(Final Report)

Steurer, W. H. ; Kaye, S.

General Dynamics Corp., San Diego, Calif. Convair Div.

Report No.: NASA-CR-143887; CASD-NAS-75-025

28 Feb 75 108p

NTIS Prices: PC A06/MF A01 Journal Announcement: GRAI7522; STAR1318

Contract No.: NAS8-29620

Materials and processes for the testing of aluminum-base fiber and particle composites, and of metal foams under extended-time low-g conditions were investigated. A wetting and dispersion technique was developed, based on the theory that under the absence of a gas phase all solids are wetted by liquids. The process is characterized by a high vacuum environment and a high temperature cycle. Successful wetting and dispersion experiments were carried out with sapphire fibers, whiskers and particles, and with fibers of silicon carbide, pyrolytic graphite and tungsten. The developed process and facilities permit the preparation of a precomposite which serves as sample material for flight experiments. Low-g processing consists then merely in the uniform redistribution of the reinforcements during a melting cycle. For the preparation of metal foams, gas generation by means of a thermally decomposing compound was found most adaptable to flight experiments. For flight experiments, the use of compacted mixture of the component materials limits low-g processing to a simple melt cycle. (Author)

Descriptors: \*Composite materials; \*Low gravity manufacturing; \*Space manufacturing; Aluminum; Reinforcing fibers; Wetting

Identifiers: NTISNASA

Section Headings: 11D (Materials--Composite Materials); 71F (Materials Sciences--Composite Materials)

466288 N75-27023/1

**Float Zone Processing in a Weightless Environment**

(Summary Report)

Fowle, A. A. ; Haggerty, J. S. ; Strong, P. F. ; Rudenberg, G. ; Kronauer, R.

Little (Arthur D.), Inc., Cambridge, Mass.

Report No.: NASA-CR-143876

Oct 74 70p

NTIS Prices: PC A04/MF A01 Journal Announcement: GRAI7522; STAR1318

Contract No.: NAS8-29877

Results are given for investigations into: (1) the physical limits which set the maximum practical diameters of Si crystals that can be processed by the float-zone method in a near weightless environment, and (2) the economic impact of large, space-produced Si crystals on the electronics industry. The stability of the melt is evaluated. Heat transfer and fluid flow within the melt as dependent on the crystal size and the degree and type of rotation imparted to the melt are studied. Methods of utilizing the weightless environment for the production of large, stress-free Si crystals of uniform composition are proposed. The economic effect of large size Si crystals, their potential applications, likely utilization and cost advantages in LSI, integrated circuits, and power devices are also evaluated. Foreseeable advantages of larger diameter wafers of good characteristics and the possibilities seen for greater perfection resulting from stress-free growth are discussed. (Author)

Descriptors: \*Silicon; \*Space manufacturing; \*Zone melting; Containerless melts; Economic analysis; Integrated circuits; Wafers; Weightlessness

Identifiers: NTISNASA

Section Headings: 22A (Space Technology--Astronautics); 84A (Space Technology--Astronautics)

463961 N75-25982/0

**Technology in Space**

Belyakov, I. T. ; Borisov, Y. D.

Kanner (Leo) Associates, Redwood City, Calif.

Report No.: NASA-TT-F-16264

Jul 75 282p

Tran-Transl. Into English of the Book "Tekhnologiya V Kosmose" Moscow, Mashinostroyeniye Press, 1974 291 p.

Document Type: Translation

NTIS Prices: PC A13/MF A01 Journal Announcement: GRAI7521; STAR1317

Contract No.: NASW-2481

The results of Soviet and foreign research in the field of production in space are discussed. Methods for manufacturing and processing various types of materials, such as ball bearings, lenses, and crystals, and the behavior of the materials in space are described. Information on assembly and installation work including joining, sealing, welding, and soldering is given. Cost advantages and disadvantages of production in space are covered. Background material to help the reader understand the characteristics of outer space and the behavior of the human body in a state of weightlessness is also included. (Author)

Descriptors: \*Aerospace environments; \*Space manufacturing; (cont. next page)

ORIGINAL PAGE IS  
OF POOR QUALITY



## DIALOG File 6: NTIS - 84-86/ISS11 (Copr. NTIS)

\*Weightlessness; Cost analysis; Production engineering; Space environment simulation; U.s.s.r.

Identifiers: NTISNASA

Section Headings: 22A (Space Technology--Astronautics)

449121 N75-19285/6

**Processing and Manufacturing in Space**

Battrick, B. T. ; Nguyen, T. D.

European Space Research Organization, Paris (France).

Report No.: ESRO-SP-101

Jul 74 358p

Conf-Proc. Of a Symp. Held at Frascati, Italy, 25-27 Mar. 1974.

Document Type: Conference proceeding

NTIS Prices: PC A16/MF A01 Journal Announcement: GRAI7514;

STAR1311

The present state of knowledge of space environment influence on the handling and behavior of materials, and on the properties of the materials processed in this environment, is reported. Reviews cover the fields of metallurgy, electronic materials, glass and ceramic technology, physical and chemical processes in fluids, electrophoretic separation, and techniques and equipment design. Some results from the Skylab program are included. Experimental designs for the Apollo Soyuz Test Project and Spacelab program are presented.

Descriptors: \*Apollo soyuz test project; \*Conferences; \*Skylab program; \*Space manufacturing; \*Spacelab; Cells (Biology); Ceramics; Composite materials; Crystal growth; Electronics; Experimental design; Furnaces; Glass; Metallurgy Onboard equipment; Semiconductors (Materials)

Identifiers: NTISNASA

Section Headings: 13H (Mechanical, Industrial, Civil, and Marine Engineering--Industrial Processes); 94G (Industrial and Mechanical Engineering--Manufacturing Processes and Materials Handling); 84GE (Space Technology--General)

447197 N75-18272/5

**Abstracts, Third Space Processing Symposium, Skylab Results**

National Aeronautics and Space Administration, Marshall Space Flight Center, Huntsville, Ala.

Report No.: NASA-TM-X-70406

1974 44p

Conf-Symp. Held at Huntsville, Ala., 30 Apr. - 1 May 1974.

Document Type: Conference proceeding

NTIS Prices: PC A03/MF A01 Journal Announcement: GRAI7513;

STAR1310

Skylab experiments results are reported in abstracts of papers presented at the Third Space Processing Symposium. Specific areas of interest include: exothermic brazing, metals melting, crystals, reinforced composites, glasses, eutectics; physics of the low-g processes; electrophoresis, heat flow, and convection demonstrations flown on Apollo missions; and apparatus for containerless processing, heating, cooling, and containing materials.

Descriptors: \*Conferences; \*Orbital workshops; \*Skylab

program; \*Space manufacturing; Apollo flights; Composite materials; Containerless melts; Crystal growth; Low gravity manufacturing

Identifiers: NTISNASA

Section Headings: 22A (Space Technology--Astronautics); 84A (Space Technology--Astronautics)

431348 N75-12017/0

**Investigation of Solidification in Zero-Gravity Environment: M553 Sphere Forming Experiment. Nickel-Silver Alloy Evaluation**

(Contractor Report, May 1972 - Dec. 1973)

Kattamis, T. Z.

Connecticut Univ., Waterbury.

Report No.: NASA-CR-129034

Dec 73 22p

NTIS Prices: PC A02/MF A01 Journal Announcement: GRAI7506;

STAR1303

Contract No.: NAS8-28734

The processing of nickel-silver alloy specimens in space is discussed. Four specimens were melted only partially, while a fifth was melted completely and assumed after solidification a perfectly spherical shape. Growth of the solid was epitaxial on the unmelted material or on the retaining string and occurred without undercooling. Solidification was dendritic in all cases with nonequilibrium silver particles forming monotellectically between dendrite arms. Substantial loss of silver by evaporation took place. Evaporation of the silver within internal gas cavities on the melt was followed by surface condensation after completion of solidification and cooling, leading to a silver-rich lining in these cavities. The material gave no microstructural evidence of any reduction in liquid convection. (Author)

Descriptors: \*Fusion (Melting); \*Nickel alloys; \*Silver alloys; \*Solidification; \*Space manufacturing; \*Weightlessness; Crystal growth; Metallurgy; Microstructure; Skylab program

Identifiers: NTISNASA

Section Headings: 13H (Mechanical, Industrial, Civil, and Marine Engineering--Industrial Processes); 94G (Industrial and Mechanical Engineering--Manufacturing Processes and Materials Handling)

420718 N74-33399/8

**Study for Identification of Beneficial Uses of Space (Bus), Phase 2. Volume 2: Technical Report. Book 2: Section 5, Appendices a Through D**

(Final Report, Dec. 1972 - Dec. 1973)

General Electric Co., Philadelphia, Pa. Missile and Space Div.

Report No.: NASA-CR-120287; DOC-73SD4281-VOL-2-BK-2-

1 Nov 73 78p

Seri-3.

NTIS Prices: PC A05/MF A01 Journal Announcement: GRAI7426;

STAR1222

(cont. next page)

## DIALOG File 6: NTIS - 64-86/ISS11 (Copr. NTIS)

Contract No.: NAS8-28179

No abstract available.

Descriptors: \*Metallurgy; \*Space manufacturing; \*Technology transfer; \*Technology utilization; Product development; Production engineering; Production planning

Identifiers: NTISNASA

Section Headings: 13H (Mechanical, Industrial, Civil, and Marine Engineering--Industrial Processes); 94A (Industrial and Mechanical Engineering--Production Planning and Process Controls); 94G (Industrial and Mechanical Engineering--Manufacturing Processes and Materials Handling)

420715 N74-33396/4

**Study for Identification of Beneficial Uses of Space, Phase 1. Volume 2, Book 2: Technical Report: Results, Conclusions and Recommendations**

(Final Report)

General Electric Co., Philadelphia, Pa. Space Div.

Report No.: NASA-CR-120284; REPT-73SD4259

23 Apr 73 152p

NTIS Prices: PC A08/MF A01 Journal Announcement: GRAI7426; STAR1222

Contract No.: NAS8-28179

A variety of technologies were investigated to determine the benefits to be derived from space activities. The subjects accepted for product development are: (1) eutectics for cold cathodes, (2) higher purity fiber optics, (3) fluidic wafers, (4) large germanium wafers for gamma ray camera, (5) improved batteries and capacitors, (6) optical filters, (7) corrosion resistant electrodes, (8) high strength carbon-based filaments for plastic reinforcement, and (9) new antibiotics. In addition, three ideas for services, involving disposal of radioactive wastes, blood analysis, and enhanced solar insulation were proposed. (Author)

Descriptors: \*Space manufacturing; \*Technology transfer; \*Technology utilization; Crystal growth; Equipment specifications; Metallography; Optical filters; Product development; Synthetic fibers; Waste disposal

Identifiers: NTISNASA

Section Headings: 22A (Space Technology--Astronautics); 84A (Space Technology--Astronautics); 84C (Space Technology--Manned Spacecraft)

420545 N74-32930/1

**Feasibility Study for the Manufacture of Zero Gravity Pharmaceuticals, Immunological, and Viral Agents, Appendices**

Little (Arthur D.), Inc., Cambridge, Mass.

Report No.: NASA-CR-120425

29 Aug 74 238p

NTIS Prices: PC A11/MF A01 Journal Announcement: GRAI7426; STAR1222

Contract No.: NAS8-29874

For abstract, see N74-32929.

Descriptors: \*Electrophoresis; \*Medicine; \*Pharmacology; \*Space manufacturing; Chemical reactions; Product development

Weightlessness

Identifiers: NTISNASA

Section Headings: 60 (Biological and Medical Sciences--Pharmacology); 57Q (Medicine and Biology--Pharmacology and Pharmacological Chemistry)

420544 N74-32929/3

**Feasibility Study for the Manufacture of Zero Gravity Pharmaceuticals, Immunological, and Viral Agents**

(Final Report)

Little (Arthur D.), Inc., Cambridge, Mass.

Report No.: NASA-CR-120424

29 Aug 74 67p

NTIS Prices: PC A04/MF A01 Journal Announcement: GRAI7426; STAR1222

Contract No.: NAS8-29874

The feasibility of extracting, isolating, purifying, separating, or preparing medical and biological products of high socio-economic value in space was studied. In particular, the study was designed to concentrate on the isolation or purification of virals, pharmaceutical and immunological agents by means of electrophoresis, as the Apollo 16 flight demonstrated that a mixed population of latex spheres (.2 and .8 microns) could be successfully separated by electrophoresis in space and without sedimentation with minimal convection. This prompted NASA scientists to look into the possibility of carrying out types of biochemical experiments that would utilize space for medical purposes. (Author)

Descriptors: \*Electrophoresis; \*Medicine; \*Pharmacology; \*Space manufacturing; Chemical reactions; Product development

Weightlessness

Identifiers: NTISNASA

Section Headings: 60 (Biological and Medical Sciences--Pharmacology); 57Q (Medicine and Biology--Pharmacology and Pharmacological Chemistry)

420539 N74-32924/4

**Research Study on Materials Processing in Space, Experiment M512**

(Final Report, 15 Jun. 1972 - 30 Nov. 1973)

Rubenstein, M.; Hopkins, R. H.; Kim, H. B.

Westinghouse Research Labs., Pittsburgh, Pa.

Report No.: NASA-CR-120418

15 Jan 73 105p

NTIS Prices: PC A06/MF A01 Journal Announcement: GRAI7426; STAR1222

Contract No.: NAS8-28727

Gallium arsenide, a commercially valuable semiconductor, has been prepared from the melt (M.P. 1237C), by vapor growth, and by growth from metallic solutions. It has been established that growth from metallic solution can produce material with high, and perhaps with the highest possible, chemical homogeneity and crystalline perfection. Growth of GaAs from

(cont. next page)

ORIGINAL PAGE IS  
OF POOR QUALITY

## DIALOG File 6: NTIS - 84-86/ISS11 (Copr. NTIS)

metallic solution can be performed at relatively low temperatures (about 600C) and is relatively insensitive to temperature fluctuations. However, this type of crystal growth is subject to the decided disadvantage that density induced convection currents may produce variations in rates of growth at a growing surface. This problem would be minimized under reduced gravity conditions. (Author)

Descriptors: \*Gallium arsenides; \*Semiconductors (Materials); \*Space manufacturing; Chemical properties; Crystal growth; Metallography; Product development

Identifiers: NTISNASA  
Section Headings: 20L (Physics--Solid-state Physics); 46D (Physics--Solid State Physics)

414664 N74-29972/8

**Materials Processing in Space M512, Phase B Report**

Pattee, H. E.; Monroe, R. E.  
Battelle Columbus Labs., Ohio.  
Report No.: NASA-CR-120266  
15 Jul 73 74p

NTIS Prices: PC A04/MF A01 Journal Announcement: GRAI7424;  
STAR1219

Contract No.: NAS8-28725

The metallographic characterization, analysis, and property measurement of ground samples for comparison with those processed on Skylab are described. Experiments on metals melting and exothermic brazing are summarized, and results are presented.

Descriptors: \*Microstructure; \*Space manufacturing; \*Weightlessness; Brazing; Materials tests; Metallography; Microanalysis; Skylab program

Identifiers: NTISNASA  
Section Headings: 11F (Materials--Metallurgy and Metallography); 71N (Materials Sciences--Nonferrous Metals and Alloys); 94G (Industrial and Mechanical Engineering--Manufacturing Processes and Materials Handling)

381656 N74-15526/8

**The Space Shuttle Payload Planning Working Groups: Volume 9: Materials Processing and Space Manufacturing**  
(Final Report)

National Aeronautics and Space Administration, Goddard Space Flight Center, Greenbelt, Md.  
Report No.: NASA-TM-X-69459  
May 73 73p

NTIS Prices: PC A04/MF A01 Journal Announcement: GRAI7409;  
STAR1206

The findings and recommendations of the Materials Processing and Space Manufacturing group of the space shuttle payload planning activity are presented. The effects of weightlessness on the levitation processes, mixture stability, and control over heat and mass transport in fluids are considered for investigation. The research and development projects include: (1) metallurgical processes, (2) electronic materials, (3) biological applications, and (4) nonmetallic materials and

processes. Additional recommendations are provided concerning the allocation of payload space, acceptance of experiments for flight, flight qualification, and private use of the space shuttle. (Author)

Descriptors: +Chemical reactions; +Space laboratories; \*Space manufacturing; \*Space missions; \*Space shuttles; \*Weightlessness; Equipment specifications; Payloads; Project management; Research projects; Test equipment

Identifiers: NTISNASA  
Section Headings: 22A (Space Technology--Astronautics); 84A (Space Technology--Astronautics); 84C (Space Technology--Manned Spacecraft)

352677 N73-27677/6

**Physical Phenomena Related to Crystal Growth in the Space Environment**

Chu, T. L.  
Southern Methodist Univ., Dallas, Tex. Electronic Sciences Center.

Report No.: NASA-CR-2281  
Jul 73 38p  
NTIS Prices: PC A03/MF A01 Journal Announcement: GRAI7322;  
STAR1118

Contract No.: NAS1-11869  
The mechanism of crystal growth which may be affected by the space environment was studied. Conclusions as to the relative technical and scientific advantages of crystal growth in space over earth bound growth, without regard to economic advantage, were deduced. It was concluded that the crucibleless technique will most directly demonstrate the unique effects of the greatly reduced gravity in the space environment. Several experiments, including crucibleless crystal growth using solar energy and determination of diffusion coefficients of common dopants in liquid silicon were recommended. (Author)

Descriptors: \*Crystal growth; \*Space manufacturing; Containerless melts; Convection; Diffusion coefficient; Experimental design; Silicon

Identifiers: NTISNASA  
Section Headings: 20B (Physics--Crystallography); 80D (Physics--Crystallography)

319795 N73-15867

**Proceedings of the Space Shuttle Sortie Workshop. Volume 2 Working Group Reports**

National Aeronautics and Space Administration, Goddard Space Flight Center, Greenbelt, Md.  
Report No.: NASA-TM-X-68842

4 Aug 72 561p  
Conf- Conf. Held At Greenbelt, Md., 31 Jun. - 4 Aug. 1972  
Document Type: Conference proceeding  
NTIS Prices: PC E14/MF A01 Journal Announcement: GRAI7308;  
STAR1106

Details are presented on the mission planning progress in  
(cont. next page)

ORIGINAL PAGE IS  
OF POOR  
QUALITY

## DIALOG File 6: NTIS - 64-86/ISS11 (Copr. NTIS)

each of the working paper reports. The general topics covered are the following: space technology; materials processing and space manufacturing; communications and navigation; earth and ocean physics; oceanography; earth resources and surface environmental quality; meteorology and atmospheric environmental quality; life sciences; atmospheric and space physics; solar physics; high energy cosmic rays; X-ray and gamma ray astronomy; ultraviolet-optical astronomy; planetary astronomy; and infrared astronomy.

Descriptors: \*Aerospace engineering; \*Conferences; \*Experimental design; \*Mission planning; \*Sortie lab; \*Space shuttles; Environmental quality; Instruments; Meteorology; Oceanography; Space manufacturing; Spaceborne astronomy

Identifiers: NTISNASA

Section Headings: 22A (Space Technology--Astronautics); 84A (Space Technology--Astronautics); 84C (Space Technology--Manned Spacecraft)

212392 AD-720 136

**Industrial Chemistry in Space**

Libby, W. F. ; Payton, P. H.

California Univ Los Angeles Dept of Chemistry

Corp. Source Codes: 072255

Report No.: AFOSR-TR-71-0595

20 Mar 70 5p

Pub. in Proceedings of the ASME Space Technology and Heat Transfer Conference, Los Angeles, Calif. 21-24 Jun 70. 70-Av/SpT-2. 5p.

Document Type: Journal article

NTIS Prices: REPRINT Journal Announcement: GRAI7109

Contract No.: AF-AFOSR-1255-67; NGL-05-007-003; AF-9538

Some aspects of chemical manufacture in an orbiting spacecraft are presented and discussed. The design and operation of a 100-meter-dia parabolic solar furnace is considered. Some further subjects of future chemical interest are also presented. (Author)

Descriptors: \*Chemical engineering; \*Space stations ; \*Solar furnaces; Space stations ; Crystal growth; Metallurgy; Astronautics

Identifiers: NTISAF

Section Headings: 22A (Space Technology--Astronautics); 7A (Chemistry--Chemical Engineering); 84A (Space Technology--Astronautics); 59B (Chemistry--Industrial Chemistry and Chemical Process Engineering)

205470 N71-11701

**Space Processing and Manufacturing**

National Aeronautics and Space Administration. Marshall Space Flight Center, Huntsville, Ala.

Report No.: NASA-TM-X-66480; ME-69-1

21 Oct 69 544p

Conf- Conf. Held At Huntsville, Ala., 21-22 Oct. 1969

Document Type: Conference proceeding

NTIS Prices: PC A23 MF A01 Journal Announcement: USGRDR710; STAR0902

No abstract available.

Descriptors: \*Conferences; \*Crystal growth; \*Forming techniques; \*Glass; \*Manufacturing; \*Metal matrix composites; \*Metal working; \*Orbital workshops; \*Production engineering; \*Space laboratories; \*Vaccines; Aerospace industry; Apollo applications program; Exobiology; Materials handling; Reduced gravity; Research and development; Weightlessness

Section Headings: 13H (Mechanical, Industrial, Civil, and Marine Engineering--Industrial Processes); 22A (Space Technology--Astronautics); 69I (Industrial and Mechanical Engineering--Manufacturing Processes); 84A (Space Technology--Astronautics)

173814 N70-20517

**Space Processing and Manufacturing**

National Aeronautics and Space Administration. Marshall Space Flight Center, Huntsville, Ala.

Report No.: NASA-TM-X-53993

5 Feb 70 554p

Document Type: Conference proceeding

NTIS Prices: PC A24 MF A01 Journal Announcement: USGRDR701; STAR0808

No abstract available.

Descriptors: \*Conferences; \*Crystal growth; \*Manufacturing; \*Metal working; \*Orbital workshops; \*Production engineering; \*Reduced gravity; \*Space laboratories; \*Weightlessness; Earth orbits; Exobiology; Experimental design; Glass; Industries; Isotope separation; Liquid metals; Sterilization; Ultrapure metals

Section Headings: 22A (Space Technology--Astronautics)

166380 N70-14651

**Space Processing and Manufacturing Meeting**

National Aeronautics and Space Administration. Marshall Space Flight Center, Huntsville, Ala.

Report No.: NASA-TM-X-62560; ME-69-1

21 Oct 69 546p

Conf- Presented At the Space Process. and Manufacturing Meeting, Msc, Huntsville, Ala., 21-22 Oct. 1969

Document Type: Conference proceeding

NTIS Prices: PC A23 MF A01 Journal Announcement: USGRDR700; STAR0804

No abstract available.

Descriptors: \*Apollo applications program; \*Applications technology satellites; \*Conferences; \*Crystal growth; \*Exobiology; \*Glass; \*Manufacturing; \*Orbital workshops; \*Production engineering; \*Research and development; \*Weightlessness; Aerospace environments; Biosatellites; Chemical reactions; Gravitational effects; Manned orbital laboratories; Materials handling; Metal working; Reduced gravity; Solid state devices; Space laboratories; Space programs; Technology utilization; Vaccines

Section Headings: 22A (Space Technology--Astronautics); 13H (cont. next page)

### **PNI DATABASE**

PNI (Pharmaceutical News Index) is a copyrighted product of Data Courier Inc., 620 South Fifth Street, Louisville, Kentucky 40202. Full-text articles of most PNI abstracts are available from Data Courier for \$15.00 each. Call 800-626-2823 (U.S.) or 800-626-0307 (Canada) for additional information or to order an article.

## DIALOG File 42: Pharmaceutical News Index 74-86/Apr

86-09345

**Riker-McDonnell Douglas looking at non-erythropoietin space projects**

FDC Reports -- "The Pink Sheet" Vol. 48, No. 11, p. T&G-,  
Codon: FPSDAN Publ.Yr: Mar 17, 1986  
Languages: ENGLISH  
Descriptors: Riker; McDonnell Douglas; discussions;  
space-processed pharmaceuticals; erythropoietin; electrophoresis  
in space technology; Ortho agreement termination; 3M

86-04819

**New erythropoietin space experiment**

SCRIP World Pharmaceutical News No. 1060, p. 25, Coden:  
SCRIDK Publ.Yr: Dec 16, 1985  
Languages: ENGLISH  
Descriptors: erythropoietin purification experiment; US  
space shuttle; McDonnell Douglas; Codon; Electrophoresis  
Operations in Space; EOS device; Rose, J.; manufacturing  
process; agreement; 3M; Riker Laboratories

86-04287

**McDonnell-3M space EPO**

SCRIP World Pharmaceutical News No. 1055, p. 9, Coden:SCRIDK  
Publ.Yr: Nov 27, 1985  
Languages: ENGLISH  
Descriptors: McDonnell Douglas; 3M; pharmaceutical products  
manufactured in space; erythropoietin; Ortho; R & D agreement  
Riker Labs; EPO venture; experiments

86-03729

**3M's Riker replaces J&J in space shuttle program**

Medical Devices, Diagnostics and Instrumentation Reports --  
"The Gray Sheet" Vol. 11, No. 47, pp. 11,12, Coden: MDDIDR  
Publ.Yr: Nov 25, 1985  
Languages: ENGLISH  
Descriptors: McDonnell Douglas; Johnson & Johnson subsidiary  
; Ortho; Electrophoresis Operation in Space; 3M subsidiary;  
erythropoietin; space shuttle program participants; Riker  
Laboratories; EOS-1 device

86-03412

**Drugs in space: McDonnell Douglas now processing erythropoietin**

FDC Reports -- "The Pink Sheet" Vol. 47, No. 49, p. T&G-,  
Codon: FPSDAN Publ.Yr: Dec 9, 1985  
Languages: ENGLISH  
Descriptors: Electrophoresis Operations in Space; EOS device  
; McDonnell Douglas; erythropoietin; Codon; Riker; Johnson &  
Johnson; agreement; Walker, C.

86-02423

**Codon (Brisbane, CA) product undergoing purification on space shuttle**

Applied Genetics News Vol. 6, No. 5, p. 6, Coden: AGNEEN  
Publ.Yr: Dec 1985  
Languages: ENGLISH  
Descriptors: space shuttle contract; Codon; McDonnell  
Douglas; Astronautics; Electrophoresis Operation in Space; EOS  
; erythropoietin; purification process; 3M; Riker Laboratories

86-00757

**Riker will take J&J's place in space shuttle**

FDC Reports - "The Pink Sheet" Vol. 47, No. 47, pp.  
T&G-1,2, Coden: FPSDAN Publ.Yr: Nov 25, 1985  
Languages: ENGLISH  
Descriptors: McDonnell Douglas; erythropoietin production;  
electrophoresis technology; Electrophoresis Operations in  
Space; R & D agreements; Riker; J & J; Ortho; Amgen;  
interleukin-2; hepatitis-B vaccine; Johnson & Johnson; EOS  
program; EOS-1 device

85-27775

**Ortho Pharmaceutical Corp. pulls out of space contract with McDonnell Astronautics**

Applied Genetics News Vol. 6, No. 3, p. 9, Coden: AGNEEN  
Publ.Yr: Oct 1985  
Languages: ENGLISH  
Descriptors: cell separation; contract termination;  
McDonnell Astronautics; electrophoresis in space; Ortho  
Pharmaceutical

85-27689

**Pharmaceuticals in space; Crystallography**

SCRIP World Pharmaceutical News No. 1038, p. 14, Coden:  
SCRIDK Publ.Yr: Sep 30, 1985  
Languages: ENGLISH  
Descriptors: pharmaceutical operations in space; McDonnell  
Douglas; Merck; Upjohn; SmithKline; US; bioprocessing in space  
; First, R.; business opportunities; market breakdown;  
forecasts; crystallography; Schering-Plough; Burroughs-Wellcome;  
Du Pont; agreements; Center for Macromolecular  
Crystallography; Pfizer; Genentech; Bugg, C.;  
alpha-2-interferon; CMC; R & D activity; Ortho  
Identifiers: table

85-27536

**UK space research offer**

SCRIP World Pharmaceutical News No. 1037, p. 4, Coden:SCRIDK  
Publ.Yr: Sep 25, 1985  
Languages: ENGLISH  
Descriptors: British Aerospace; UK; pharmaceutical companies  
(cont. next page)

## DIALOG File 42: Pharmaceutical News Index 74-86/Apr

; European space platform; R & D project search; Eureka; Thomas, W.

85-24131

**Ortho dropping out of McDonnell Douglas space shuttle program**

FDC Reports - "The Pink Sheet" Vol. 47, No. 37, pp. T&G-8,9, Coden: FPSDAN Publ.Yr: Sep 16, 1985

Languages: ENGLISH

Descriptors: Ortho; McDonnell Douglas; electrophoresis operations in space; J & J; EOS program; agreement termination; Du Pont; 3M; Honeywell; R & D agreements

85-17039

**Contracts and agreements; Endotronics, Inc. (Minneapolis, MN), and McDonnell Douglas Co. (St. Louis, MO) Sign contract for Endotronics to culture a cell line**

Applied Genetics News Vol. 5, No. 11, p. 4, Coden: AGNEEN Publ.Yr: Jun 1985

Languages: ENGLISH

Descriptors: Electrophoresis Operations in Space device; McDonnell Douglas; cell culture fluid; Endotronics-Summa joint venture; ACUSYST-P; automated cell culture system; Endotronics; biological materials separation; agreement

85-05172

**Blood storage experiment on space shuttle**

Medical Devices, Diagnostics and Instrumentation Reports - "The Gray Sheet" Vol. 11, No. 6, pp. I&W-9,10, Coden: MDDIDR Publ.Yr: Feb 11, 1985

Languages: ENGLISH

Descriptors: space shuttle projects; weightlessness effects Arthur D. Little; participants; NASA funding; Surgenor, D.; Initial Blood Storage Experiment; National Aeronautics & Space Administration; McDonnell Douglas; Johnson & Johnson; electrophoresis

85-01781

**Spurs to space production**

SCRIP World Pharmaceutical News No. 954, p. 20, Coden: SCRIDK Publ.Yr: Dec 3, 1984

Languages: ENGLISH

Descriptors: Bier, M.; NASA grant; space production; electrophoresis; Schering-Plough; Abbott; Genentech; Hanna Labs; Upjohn; Merck; reduced-rate flights; R & D phases of commercial projects; Fairchild Industries; contracts; US; NASA's space programme; isoelectric focusing

85-01414

**Space hormone contaminated**

SCRIP World Pharmaceutical News No. 950, p. 21, Coden: SCRIDK Publ.Yr: Nov 19, 1984

Languages: ENGLISH

Descriptors: hormone manufactured in space; US; McDonnell Douglas; contamination; Walker, C.; Rose, J.; electrophoresis operations; Johnson & Johnson

84-21556

**McDonnell Douglas' initial electrophoresis material found contaminated**

Medical Devices, Diagnostics and Instrumentation Reports - ("The Gray Sheet" Vol. 10, No. 46, p. 14, Coden: MDDIDR Publ.Yr: Nov 12, 1984

Languages: ENGLISH

Descriptors: McDonnell Douglas; electrophoresis operations in space; Ortho; Johnson & Johnson; Walker, C.; contamination problem

84-20519

**Caution on drugs in space**

SCRIP World Pharmaceutical News No. 938, p. 17, Coden: SCRIDK Publ.Yr: Oct 8, 1984

Languages: ENGLISH

Descriptors: drug manufacture in space; Middle East Health article; Rockwell International; limitations; hormone product Johnson & Johnson; Ortho; McDonnell Douglas; electrophoresis; Washington University; pancreatic beta-islet cells

84-15909

**Future strategies & opportunities for the industry; The consumerist challenge financial status Future R & D progress New markets Benefits of new drugs Drugs in space**

SCRIP World Pharmaceutical News No. 913, pp. 12,13, Coden: SCRIDK Publ.Yr: Jul 11, 1984

Languages: ENGLISH

Descriptors: Pharma '84; Switzerland; pharmaceutical industry; strategies; challenges; Newbould, B.; Burley, D.; credibility gap; von Grebmer, K.; consumerist opposition; Schneider, N.; financial constraints; biotechnology; R & D initiatives; limited partnerships; Carpenter, P.; Alza TTS Research Partners; Stada; Alza Oros Products; Recordati; collaboration; Barker, R.; Smeets, P.; biologically-driven research; home care market; Wolfe, A.; growth estimates; home infusion therapy industry; drug delivery systems; Travenol; continuous ambulatory peritoneal dialysis; Abbott; patient-controlled analgesia; IMED; Warner-Lambert; IVAC; Lilly; Valley Lab; Pfizer; cost-containment schemes; Paterson, M.; Tagamet; cimetidine; SmithKline; quality of life; auranofin; Ridaura; Squibb; Capoten; captopril; Spacelab programme; Oser, H.

Identifiers: 1984-1988; table

## DIALOG File 42: Pharmaceutical News Index 74-86/Apr

84-06350

**J&J/McDonnell Douglas electrophoresis in space project**

Medical Devices, Diagnostics and Instrumentation Reports -  
('The Gray Sheet' Vol. 10, No. 12, pp. 12,13, Coden: MDDIDR  
Publ.Yr: Mar 19, 1984

Languages: ENGLISH

Descriptors: pharmaceutical specialist participation;  
Walker, C.; Rose, J.; experiments; development schedule;  
Johnson & Johnson; McDonnell Douglas; J & J; electrophoresis  
in space; space shuttle flights; NASA cooperation; Fairchild;  
National Aeronautics & Space Administration; SII Corp.;  
production units

84-05931

**J&J/McDonnell Douglas electrophoresis in space project will  
put pharmaceutical specialist on June flight of space shuttle  
Discovery**

FDC Reports - ('The Pink Sheet' Vol. 46, No. 11, pp. 3.,  
Coden: FPSDAN Publ.Yr: Mar 12, 1984

Languages: ENGLISH

Descriptors: McDonnell Douglas; Walker, C.; pharmaceutical  
production specialist in space; electrophoresis; J & J; space  
bioprocessing project; Rose, J.; Johnson & Johnson; production  
schedule; NASA participation; commercial program; National  
Aeronautics and Space Administration; Fairchild; SII Corp.;  
biotechnology development; seminar/participants; Alpha  
Therapeutics; Cetus; Ciba-Geigy; DuPont; Lilly; Schering;  
Smith Labs; Scharp, D.

83-19062

**NASA to set up drug research centres**

SCRIP World Pharmaceutical News No. 835, p. 6, Coden: SCRIDK  
Publ.Yr: Oct 5, 1983

Languages: ENGLISH

Descriptors: NASA; US; university centres; pharmaceutical  
research; Halpern, R.; Johnson & Johnson; electrophoresis;  
National Aeronautics & Space Administration

83-18355

**Orbiting drug plant by 1987?**

SCRIP World Pharmaceutical News No. 825 & 826, p. 13,  
Coden: SCRIDK Publ.Yr: Sep 5, 1983

Languages: ENGLISH

Descriptors: Johnson and Johnson; McDonnell Douglas; US;  
space shuttle flights; orbiting drug production plant; Rose,  
J.; electrophoresis

83-17389

**University centers for pharmaceutical research to be  
established**

Drug Research Reports - ('The Blue Sheet' Vol. 26, No. 38,  
pp. 12,13, Coden: DRRSAL Publ.Yr: Sep 21, 1983

Languages: ENGLISH

Descriptors: National Aeronautics & Space Administration;  
Halpern, R.; university centers; pharmaceutical research; NASA  
plans; commercialization possibilities; McDonnell Douglas;  
Johnson & Johnson; electrophoresis; space shuttle flights;  
space projects

83-16012

**NASA bioprocessing/pharmaceutical research university  
centers**

Medical Devices, Diagnostics and Instrumentation Reports -  
('The Gray Sheet' Vol. 9, No. 38, p. 16, Coden: MDDIDR  
Publ.Yr: Sep 19, 1983

Languages: ENGLISH

Descriptors: Halpern, R.; university centers; biomedical  
research; NASA sponsorship; Stucki, J.; National Aeronautics &  
Space Administration; bioprocessing/pharmaceutical research  
field; McDonnell Douglas; J & J; electrophoresis purification  
space projects

83-15740

**NASA pharmaceutical research university centers**

FDC Reports - ('The Pink Sheet' Vol. 45, No. 38, p. T&G-,  
Coden: FPSDAN Publ.Yr: Sep 19, 1983

Languages: ENGLISH

Descriptors: Halpern, R.; university centers; Dear Colleague  
announcement; NASA sponsorship; National Aeronautics & Space  
Administration; bio-processing/pharmaceutical research field;  
McDonnell Douglas; electrophoresis purification; J & J; space  
projects; NASA policy; commercialization

ORIGINAL PAGE IS  
OF POOR QUALITY



## DIALOG File 42: Pharmaceutical News Index 74-86/Apr

86-04287

**McDonnell-3M space EPO**

SCRIP World Pharmaceutical News No. 1055, p. 9, Coden:SCRIDK

Publ.Yr: Nov 27, 1985

Languages: ENGLISH

Descriptors: McDonnell Douglas; 3M; pharmaceutical products  
manufactured in space; erythropoietin; Ortho; R & D agreement  
Riker Labs; EPO venture; experiments

84-15389

**Monodisperse latex microspheres to be first commercial space product**

Medical Devices, Diagnostics and Instrumentation Reports -

('The Gray Sheet' Vol. 10, No. 31, pp. I&amp;W-10,11, Coden:

MDDIDR Publ.Yr: Jul 30, 1984

Languages: ENGLISH

Descriptors: National Aeronautics and Space Administration;  
National Bureau of Standards; NBS standard reference material  
medical applications; monodisperse latex spheres; NASA  
announcement; Vanderhoff, J.; production plans

84-15388

**Administration's space commercialization policy**

Medical Devices, Diagnostics and Instrumentation Reports -

('The Gray Sheet' Vol. 10, No. 31, pp. I&amp;W-9,10, Coden:

MDDIDR Publ.Yr: Jul 30, 1984

Languages: ENGLISH

Descriptors: extraterrestrial business activities;  
commercial use of space; tax incentives; Administration policy  
; Reagan, R.; antitrust considerations; Johnson & Johnson;  
McDonnell Douglas; R & D focusORIGINAL PAGE IS  
OF POOR QUALITY

**APPENDIX 6**

**EXPLANATORY CHARTS AND ADDITIONAL INFORMATION**

## TYPES OF INDUSTRY/NASA AGREEMENTS

---

- **Industrial Guest Investigator (IGI)**
- **Technical Exchange Agreement (TEA)**
- **Joint Endeavor Agreement (JEA)**
- **Space Services Development Agreement (SSDA)**
- **Launch Services Agreement (LSA)**
- **Memorandum of Understanding (MOU)**
- **Agreement (negotiated for special circumstances such as a specific project)**

# AGREEMENTS

---

## JEA APPROPRIATE WHERE:

1. R&D oriented
2. Commercial potential
3. U.S. corporation

## JEA INAPPROPRIATE WHERE:

1. Revenue producing
2. Avoids procurement regulations
3. Able to compete on the merits
4. Not R&D

# COMMON PRINCIPLES-- NASA/INDUSTRY AGREEMENTS

---

- **Technical idea**
- **Partnerships**
- **No exchange of funds**
- **Patent and data rights**
- **Mutual benefit**

# REQUIREMENTS FOR AN SSDA

---

- 1. Company Business Plan acceptable to NASA**
- 2. First flight(s) of a new industry**
- 3. Significant national economic or social benefit**
- 4. Reasonable expectation of launch charge recovery in accordance with agreed terms**

# LAUNCH SERVICES AGREEMENT (SHUTTLE)

---

---

- **Launch on Shuttle**
- **Standard package of services**
- **Risk allocation**
- **Financial arrangements**
- **Patent and data rights**
- **Boilerplate**
- **Special services**

# JOINT ENDEAVOR AGREEMENT

---

- No exchange of funds
- Quid pro quo
- Data rights protected
- Patent rights protected
- Company responsibilities
- NASA responsibilities
- Exclusivity
  - Process
  - Against another company
  - Against the Government
- Boilerplate



# TECHNICAL EXCHANGE AGREEMENT

---

- **No flight involved**
- **Exchange of technical information**
- **Ground based research analysis**
- **Minimum expense, paid by company**
- **NASA gets access to company research**

## 1985 SELECTED CCDS

---

- **Battelle Columbus Laboratories:**      **Multiphase materials processing**      **\$850K**
  
- **University of Alabama, Birmingham:**      **Macromolecular crystallography**      **\$735K**
  
- **University of Alabama, Huntsville:**      **Materials processing**      **\$750K**
  
- **Institute for Technology Development:**      **Remote sensing from space**      **\$1,000K**
  
- **Vanderbilt University:**      **Metallurgical processing**      **\$1,140K**

**\$4,475**

# AREAS OF POTENTIAL COMMERCIAL USE

