

Safety Considerations of Lithium-Thionyl Chloride Cells

Subbarao Surampudi
Gerald Halpert
Irving Stein

(NASA-CR-180129) SAFETY CONSIDERATIONS OF
LITHIUM-THIONYL CHLORIDE CELLS (Jet
Propulsion Lab.) 85 p CSCL 10B

N87-17396

G3/44 43691
Unclas

June 1, 1986



National Aeronautics and
Space Administration
Jet Propulsion Laboratory
California Institute of Technology
Pasadena, California

JPL PUBLICATION 86-15

Safety Considerations of Lithium-Thionyl Chloride Cells

Subbarao Surampudi
Gerald Halpert
Irving Stein

June 1, 1986

NASA

National Aeronautics and
Space Administration

Jet Propulsion Laboratory
California Institute of Technology
Pasadena, California

The research described in this publication was carried out by the Jet Propulsion Laboratory, California Institute of Technology, under a contract with the National Aeronautics and Space Administration.

Reference herein to any specific commercial product, process, or service by trade name, trademark, manufacturer, or otherwise, does not constitute or imply its endorsement by the United States Government or the Jet Propulsion Laboratory, California Institute of Technology.

ABSTRACT

In spite of many attractive features, the use of spirally wound lithium-thionyl chloride (Li-SOCl_2) cells is currently limited because of their hazardous behavior. Unsafe incidents reported thus far have ranged from mild venting of toxic materials to violent explosions and fires. These incidents may be related to both user- and manufacturer-induced causes. User-induced causes may be attributed to operational, abusive, or handling conditions to which the cell is subjected. Manufacturer-induced causes may be related to design and/or quality control deficiencies.

Many explanations have been offered to explain the unsafe behavior of the cells under the above operating and abuse conditions. Explanations fall into two categories: 1) thermal mechanisms and 2) chemical mechanisms. However, it is quite difficult to separate the effect of each. The impact of both may be responsible for cell venting or explosion. Some safety problems encountered with these cells also may be due to design deficiencies and ineffective quality control during cell fabrication.

A well-coordinated basic and applied research program is needed to develop safe Li-SOCl_2 cells. Recommendations include: 1) learning more about Li-SOCl_2 cell chemistry, 2) modeling cell and battery behavior, 3) optimizing cell design for safety and performance, 4) implementing quality control procedures, and 5) educating users.

ACKNOWLEDGMENTS

The authors acknowledge the support of D. Schnyer, E. VanLandingham and J. Ambrus of the Office of Aeronautics and Space Technology, NASA Headquarters. They also thank the members of the Electrochemical Power Group, V. Ang, S. Dawson, F. Deligiannis, and H. Frank, and the members of the Solid State Science Group, B. Carter, R. Williams, D. Shen, and R. Somoano, who participated in providing information and reviewing this document. The document also has been strengthened by the suggestions of P. Bro, consultant; James J. Auburn, AT&T Bell Labs; Carl Schlaikjer, Duracell Labs; Harlan F. Bittener, Aerospace Corp.; and K. M. Abraham, EIC Corp. One of the authors, S. Subbarao, acknowledges the fellowship received from the National Research Council, Washington, D.C.

CONTENTS

<u>Section</u>	<u>Page No.</u>
ABSTRACT	iii
ACKNOWLEDGMENTS	iv
1 INTRODUCTION	1-1
2 DESCRIPTION OF THE Li-SOCl ₂ CELL	2-1
3 RECORDED SAFETY INCIDENTS	3-1
4 CLASSIFICATION OF HAZARDS AND ANALYSIS OF FACTORS AFFECTING SAFETY	4-1
5 USER-INDUCED FACTORS	5-1
5.1 NORMAL OPERATION	5-2
5.1.1 Electrical	5-2
5.1.1.1 Discharge Rate	5-2
1) Overpressurization	5-2
2) Thermal Runaway	5-5
3) Hazardous Intermediates	5-8
Suggested Improvements	5-8
5.1.1.2 Duty Cycle	5-9
5.1.2 Environment	5-10
5.1.2.1 Temperature	5-10
Suggested Improvements	5-10
5.1.2.2 Vibration and Shock	5-13
5.1.2.3 Vacuum	5-13

CONTENTS (Continued)

5.2	ABUSE	5-14
5.2.1	Electrical Abuse	5-14
5.2.1.1	Short Circuit	5-14
	Suggested Improvements	5-15
5.2.1.2	Forced Over-Discharge (Reversal)	5-18
	1) Carbon-Limited Cells	5-18
	2) Anode-Limited Cells	5-23
	3) Solvent/Thionyl Chloride-Limited Cells	5-28
	Suggested Improvements	5-29
5.2.1.3	Charging	5-30
5.2.2	Physical/Mechanical Abuse	5-33
5.2.3	Thermal/Chemical Abuse	5-33
5.3	NON-OPERATIONAL CONDITIONS	5-33
5.3.1	Handling	5-33
5.3.1.1	Storage	5-34
5.3.1.2	Transportation	5-36
5.3.2	Disposal	5-36
6.	MANUFACTURER-INDUCED FACTORS	6-1
6.1	CELL DESIGN	6-1
6.1.1	Electrochemical	6-1
6.1.2	Mechanical	6-2
6.1.2.1	Structural	6-2
6.1.2.2	Thermal	6-4
6.1.3	Electrical	6-4

CONTENTS (Continued)

6.2	QUALITY CONTROL	6-4
7.	RECOMMENDATIONS FOR IMPROVING THE SAFETY OF Li-SOCl ₂ CELLS . .	7-1
7.1	FUNDAMENTAL UNDERSTANDING	7-1
7.2	CELL DESIGN	7-2
7.3	QUALITY CONTROL	7-3
7.4	USER EDUCATION	7-3
8.	SUMMARY AND CONCLUSIONS	8-1

Appendices

APPENDIX A - DOT-E 7052 (Fifteenth Revision)	A-1
APPENDIX B - REFERENCES	B-1

Figures

1-1.	Energy and Power Characteristics of Primary Cells . .	1-2
1-2.	Applications for Li-SOCl ₂ Cells	1-3
2-1.	Schematic of a Li-SOCl ₂ Primary Cell	2-2
2-2.	Typical Cylindrical Cell Construction Details	2-4
4-1.	Classification of the Factors Responsible for the Unsafe Behavior of Li-SOCl ₂ Cells	4-3
5-1.	Effect of Discharge Rate on Li-SOCl ₂ Cell Performance	5-3
5-2.	Influence of Discharge Rate on Li-SOCl ₂ Cell Safety .	5-4
5-3.	Heat Generation During Discharge of a Li-SOCl ₂ Cell .	5-6
5-4.	Effect of Temperature on Li-SOCl ₂ Cell Performance .	5-11
5-5.	Influence of Temperature on Li-SOCl ₂ Cell Safety . . .	5-12

CONTENTS (cont 'd)

Figures (Continued)

5-6.	Pressure, Temperature, Voltage, and Current During Li-SOCl ₂ Cell Shorting	5-16
5-7.	Influence of Short Circuit on Li-SOCl ₂ Cell Safety	5-17
5-8.	Discharge and Reversal of a Li-SOCl ₂ Cell	5-19
5-9.	Influence of Reversal on Li-SOCl ₂ Cell at Ambient Temperature	5-20
5-10.	Discharge and Reversal of a Carbon-Limited Li-SOCl ₂ Cell (2 ma/cm)	5-22
5-11.	Discharge and Reversal of a Lithium-Limited Li-SOCl ₂ Cell (2 ma/cm)	5-25
5-12.	Discharge and Reversal of an Anode-Limited (Not Lithium Limited) Li-SOCl ₂ Cell	5-26
5-13.	Characteristics of Li-SOCl ₂ During Charge	5-31
5-14.	Influence of Charging on Li-SOCl ₂ Cell Safety	5-32
5-15.	Effect of Storage Temperature on Li-SOCl ₂ Cell Performance	5-35
6-1.	Specific Conductivities of LiAlCl ₂ -SOCl ₂ and Li ₂ B ₁₀ Cl ₁₀ -SOCl ₂ Electrolytes as a Function of Salt Concentration	6-3

Tables

1-1.	Companies Selling Li-SOCl ₂ Cells	1-4
2-1.	Postulated Reaction Mechanisms for the Reduction of Thionyl Chloride	2-3
5-1.	Overview of Reversal Processes	5-21
5-2.	Reactions During Lithium-Limited Reversal	5-27
6-1.	Possible Impurities in Various Materials of Li-SOCl ₂ Cells	6-5

SECTION 1

INTRODUCTION

The lithium-thionyl chloride (Li-SOCl₂) cell possesses higher energy density than any currently available primary cells. The cell also has many other desirable features: high operating voltage, excellent voltage stability over 95 percent of the discharge, operating capabilities over a wide temperature range (-40°C to +80°C), exceptionally long storage life, and low cost of materials.¹⁻⁵ Figure 1-1 offers an energy/power performance comparison of various primary electrochemical systems.

In view of these features, NASA is considering using the Li-SOCl₂ system as a source of electrical power in future space missions. Among the potential applications are the shuttle, space station, planetary probes, orbital transfer vehicles, solid rocket boosters, stand-alone platforms, astronaut equipment, etc. (Figure 1-2). The development of Li-SOCl₂ cells has been assigned to JPL, which has been designated by NASA Headquarters as the lead center for lithium electrochemical technology. The prime objective of this program is to develop aerospace quality, safe Li-SOCl₂ cells capable of being discharged in 2-plus hours (<C/2*rate), having an energy density of 300 Wh/kg, and an active shelf life of 5 years.

Li-SOCl₂ cells of various capacities have already been developed by industry (Table 1-1) for various applications⁶ (mostly for rates less than C/10). However, the use of these cells is currently limited for space use because of reported hazardous behavior.⁷⁻¹¹ The safety issue is of prime concern for spaceflight applications, especially when personnel are involved. The unsafe incidents reported to date have ranged from mild venting of toxic materials to violent explosions and fires. So far, these cells have not been developed to NASA high-reliability aerospace requirements.

As part of its overall responsibility for developing safe space quality cells, JPL has undertaken a coordinated basic and applied research program to achieve an understanding of the various chemical and electrochemical processes that govern the safety and performance of these cells. This understanding is being applied to the selection of materials, cell design, and fabrication. Major technical questions that are being addressed in the safety area of the program are: (1) under what operating and handling conditions do the cells vent or explode, (2) why do the cells vent or explode, and (3) under what conditions do they operate safely? This report has been prepared to address these questions and reviews work done to date at JPL and elsewhere on the safety aspects of Li-SOCl₂ cells. This report attempts to identify the real safety issues and provide suggestions for overcoming the associated problems.

• C/2 rate refers to the current (rate) at which the nominal capacity will be removed in 2 hours: e.g., 5 amps for a normal 10 Ah cell.

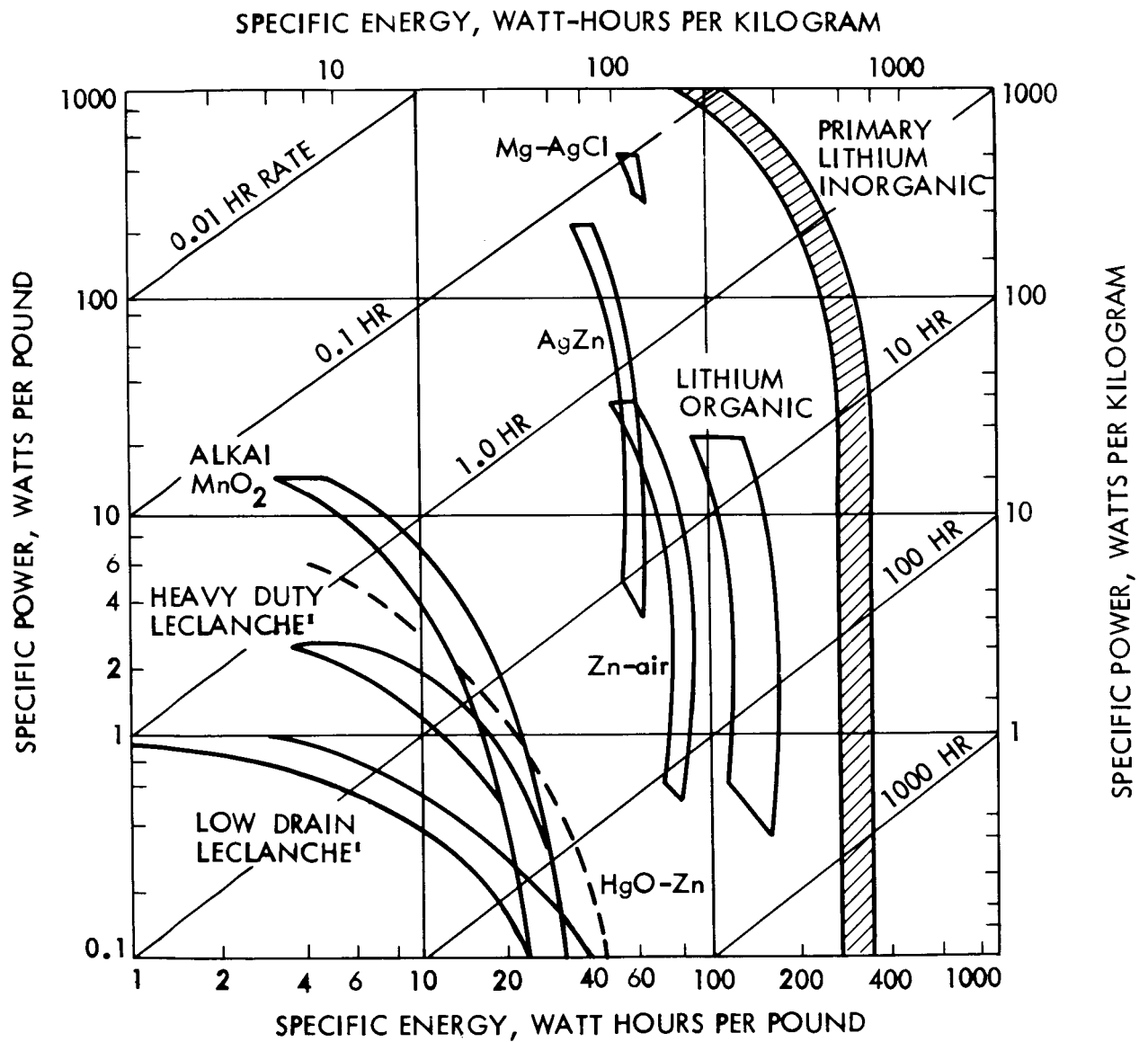

Figure 1-1. Energy and Power Characteristics of Primary Cells

ORIGINAL PAGE IS
OF POOR QUALITY

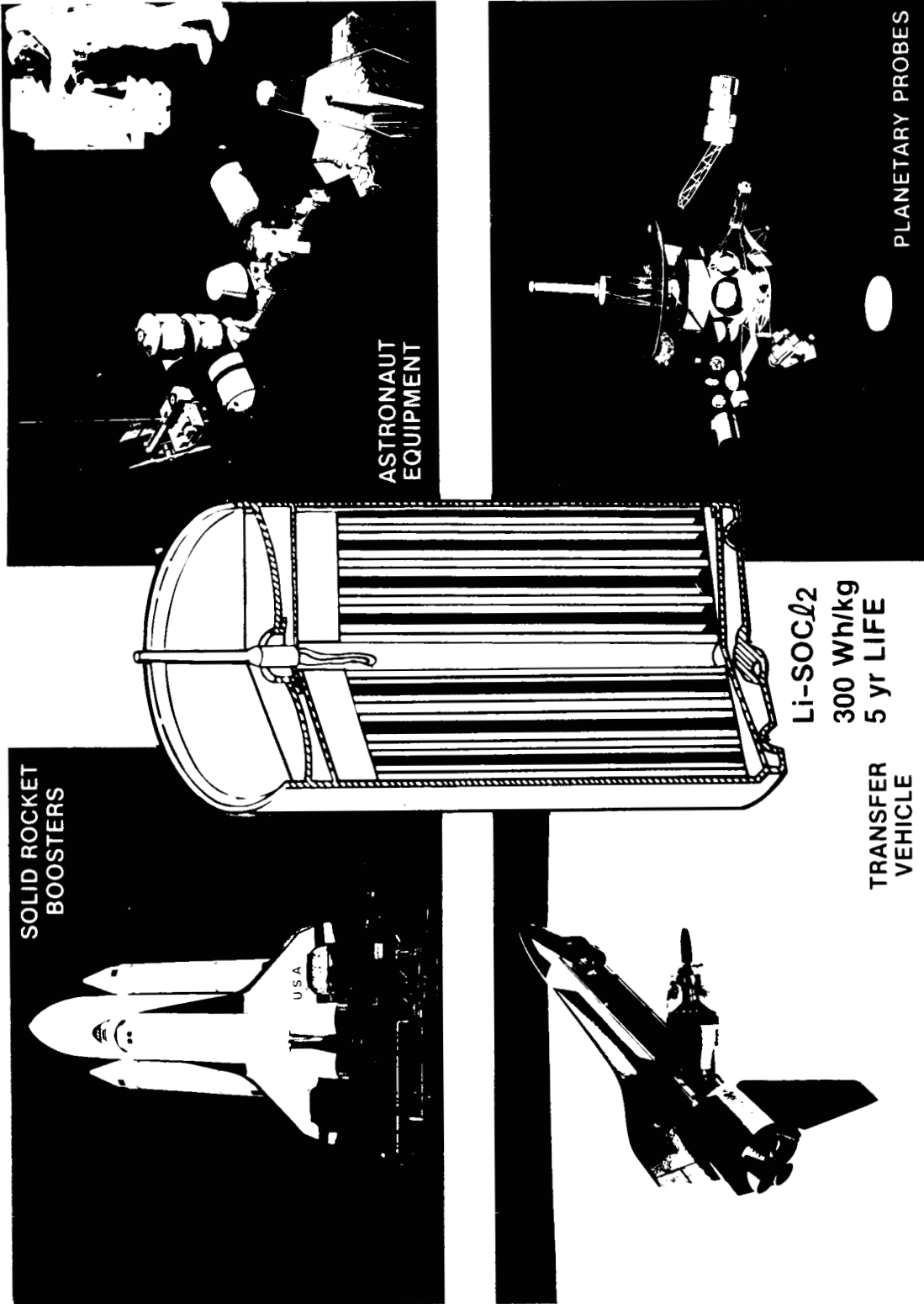

Figure 1-2. Applications for Li-SOCl₂ Cells

Table 1-1. Companies Selling Li-SOCl₂ Cells⁶

	AA	C	D	2D	BUTTON	PRISMATIC	OTHER
ALTUS CORPORATION	W	W	W		✓	1604	F; R
EAGLE-PICHER INDUSTRIES	6 TYPES	0.2-27	Ah	✓	B		R; ALSO Cr (SO ₂ Cl ₂ /Cl ₂)
ELECTROCHEM INDUSTRIES	W	W	W				1/2 AA
GTE SYLVANIA	B	B	B	B		TO 10 KAh	1/2 AA
A/S HELLESENS AND HELLESENS BATTERY ENG.	B	B	B	B	20 mW		1/2 AA SO ₂ Cl ₂
HITACHI MAXELL, LTD	5 SMALL CYLINDRICALS, LOW RATE						
HONEYWELL POWER SOURCES CENTER	BOTH W AND B, SMALL CYLINDRICALS (ALSO SO ₂ Cl ₂ ; R)						
JAPAN STORAGE BATTERY CO. LTD	CYLINDRICAL AND DISC, 4.5 Ah TO 100 Ah						
MEDTRONIC	D-SHAPED, 2.3 OR 2.7 Ah, B						
POWER CONVERSION	B	B	B				1/2 AA 2/3 AA
SAFT AMERICA, INC.	B	W	W		1604		1/2 AA, AAA
SILBERKRAFT	.2 Ah BUTTONS; CYLINDRICALS TO 27.5 Ah. EUROPE						
SONNENSCHNEIN (TADIRAN CELLS)	0.3-1.5 Ah BUTTONS; 0.55-30 Ah CYLINDRICALS						
TADIRAN	B	B	B		✓		1/2 AA
TOSHIBA	B						
UNIVERSITY OF TEL AVIV	W, UP TO D SIZE						
UNION CARBIDE	B					1604	CALCIUM 1/2 AA, Cr

* ✓ = YES
W = WOUND OR HIGH RATE (see Fig 4)
B = BOBBIN OR LOW RATE (see Fig 4)
Cr = CRIMPED SEAL
R = RESERVE BATTERY

SECTION 2

DESCRIPTION OF THE Li-SOCl₂ CELL

The Li-SOCl₂ cell (Figure 2-1) consists of a lithium (Li) foil anode, a porous carbon (C) cathode, and a neutral solution of lithium tetrachloroaluminate (LiAlCl₄) in thionyl chloride (SOCl₂) as the electrolyte. The electrodes are physically separated by a glass fiber paper. In these cells, Li is the anode active material and SOCl₂ serves as both a cathodic reactant (catholyte) and solvent for the electrolyte. The carbon electrode has various roles in this system. It acts as a catalyst for the reduction of SOCl₂; together with an expanded metal screen it functions as a current collector, and also serves as a container for the insoluble discharge products. The electrochemical reaction is not yet fully understood, but the overall reaction is believed to be:¹²⁻¹³

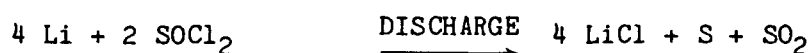

The details of various reaction mechanisms proposed for the reduction of SOCl₂¹⁴⁻¹⁶ are given in Table 2-1. Thermodynamically, Li and SOCl₂ together are unstable and should react vigorously. The observed stability of the Li anode is due to the presence of a LiCl protective film present on its surface which prevents further attack by SOCl₂.¹⁷ Hence, any condition that can lead to the disruption of the protective film may make the cell potentially hazardous. It is also known that both Li and SOCl₂ are quite moisture sensitive. Any situation that brings these materials into contact with water vapor (via humidity or impurity) may also cause safety problems.

The cell exhibits an open circuit voltage of about 3.65 V at 20°C-30°C. The theoretical specific energy of the electrochemical reaction is 1453 Wh/kg at 3.6 V. More than half of the theoretical specific energy has been realized in manufactured cells of low-rate design.

Cells have been fabricated in many configurations such as cylindrical, button, disc, and prismatic shapes depending on the application. Jellyroll-type construction (Figure 2-2) is used in cylindrical cells required for low- to moderate-rate (<C/2) applications. Bobbin-type construction (Figure 2-2) is preferred for cylindrical cells required for very low-rate applications (<C/100). Both types of cells employ a neutral electrolyte (1.5M-1.8M LiAlCl₄ in SOCl₂). Some very high-rate (>C/2) reserve type cells have also been developed. They use acidic electrolytes (typically 1.9M LiCl-2.2M AlCl₃ in SOCl₂), which result in high self-discharge rates and, therefore, must have the electrolyte isolated from the electrodes until use. Reserve cells are not considered in this review. This document focuses on the safety of spirally wound cylindrical cells.

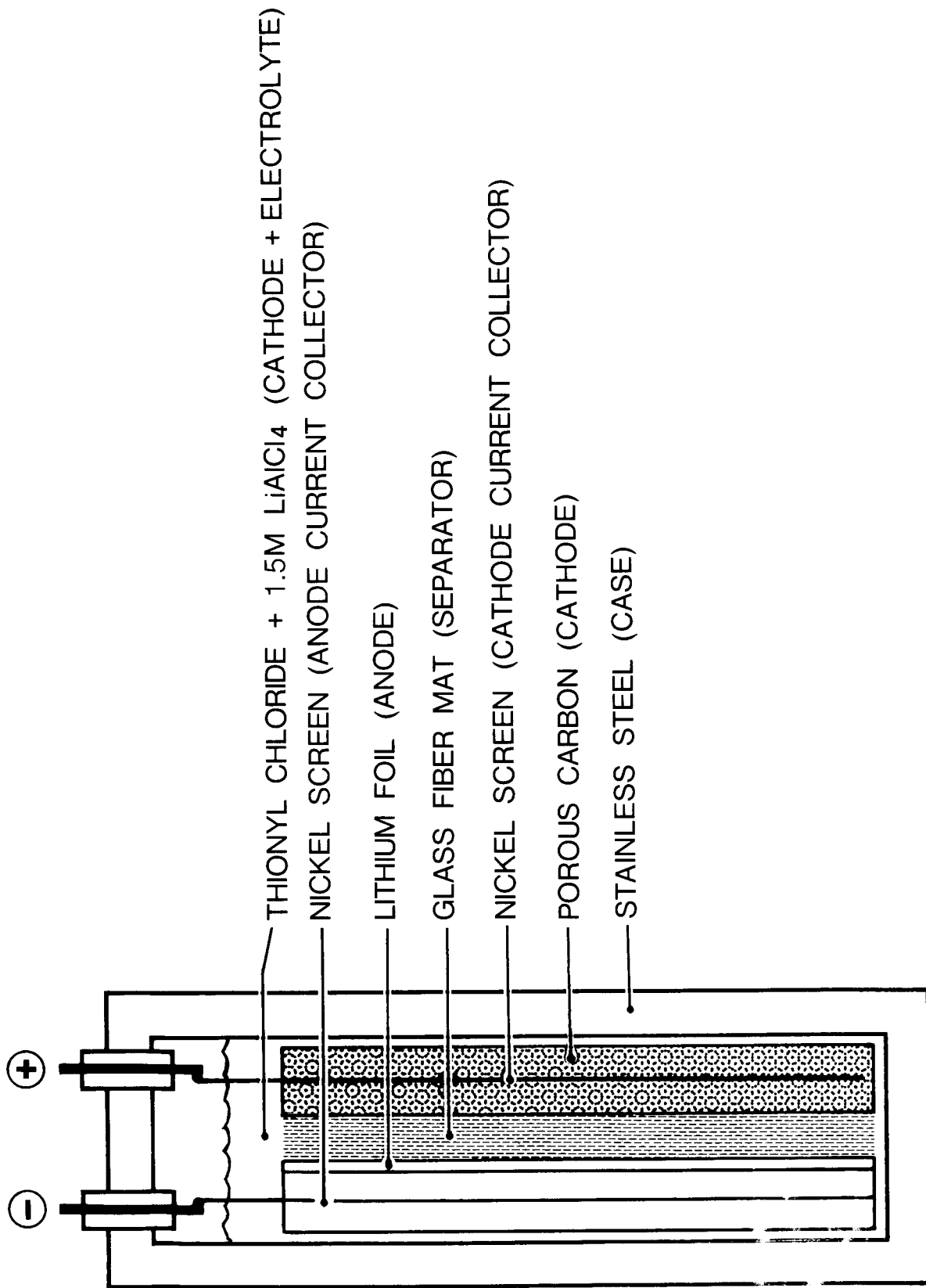
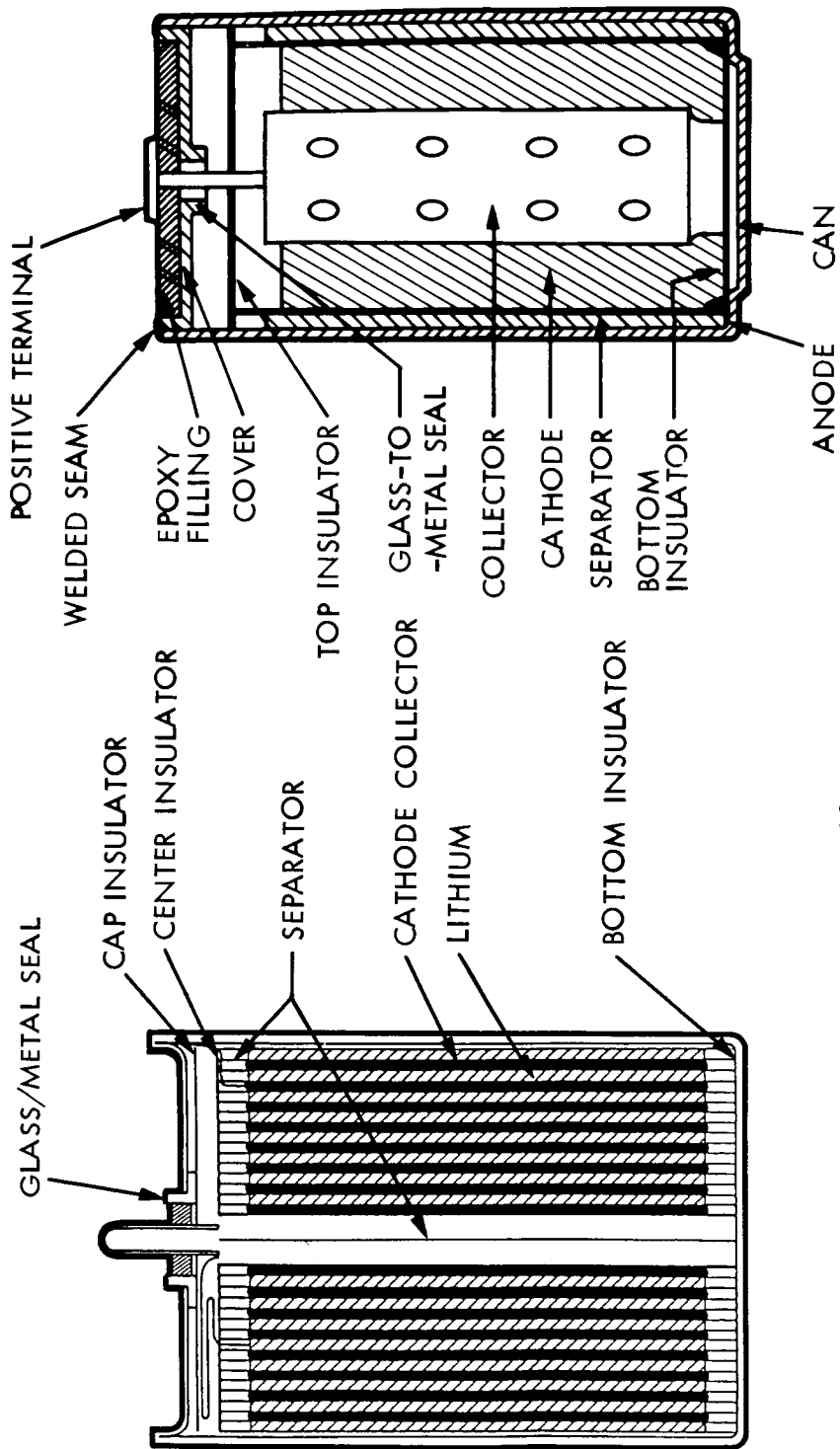

Figure 2-1. Schematic of a Li-SOCl₂ Primary Cell

Table 2-1. Postulated Reaction Mechanisms for the Reduction of
Thionyl Chloride

OVERALL REACTION: $2\text{SOCl}_2 + 4\text{e}^- \longrightarrow \text{S} + \text{SO}_2 + 4\text{Cl}^-$		
I. BOWDEN AND DEY ¹⁴	II. BLOMGREN et al. ¹⁵	III. CARTER et al. ¹⁶
$\text{SOCl}_2 + \text{e}^- \longrightarrow \text{SOCl} + \text{Cl}^-$ $\text{SOCl} + \text{e}^- \longrightarrow \text{SO} + \text{Cl}^-$ $\text{SO} + \text{SOCl}_2 \rightleftharpoons \text{SO} \cdot \text{SOCl}_2$ $\text{SO} \longrightarrow (\text{SO})_x$ $(\text{SO})_x \longrightarrow x \text{S} + x \text{SO}_2$ <ul style="list-style-type: none"> • $(\text{SO})_x$ A HAZARDOUS INTERMEDIATE 	$\text{SOCl}_2 + \text{e}^- \longrightarrow \text{SOCl} + \text{Cl}^-$ $2\text{SOCl} \longrightarrow \text{SO}_2 + \text{SCl}_2$ $\text{SCl}_2 + \text{e}^- \longrightarrow \text{SCl} + \text{Cl}^-$ $2 \text{SCl} \longrightarrow \text{S}_2\text{Cl}_2$ $\text{S}_2\text{Cl}_2 + 2 \text{e}^- \longrightarrow 2\text{S} + 2\text{Cl}^-$ <ul style="list-style-type: none"> • NO APPARENT HAZARDOUS INTERMEDIATE 	$\text{SOCl}_2 + \text{e}^- \longrightarrow \text{OSCl} + \text{Cl}^-$ $\text{OSCl} \longrightarrow \text{OClS}$ $2 \text{OClS} \longrightarrow (\text{OClS})_2$ $(\text{OClS})_2 \longrightarrow \text{SO}_2 + \text{SCl}_2$ $2 \text{SCl}_2 \rightleftharpoons \text{S}_2\text{Cl}_2 + \text{Cl}_2$ $\text{SO}_2 + \text{Cl}_2 \rightleftharpoons \text{SO}_2\text{Cl}_2$ $\text{SCl}_2 + 2\text{e}^- \longrightarrow \text{S} + 2 \text{Cl}^-$ $\text{S}_2\text{Cl}_2 + 2\text{e}^- \longrightarrow 2 \text{S} + 2 \text{Cl}^-$ $\text{Cl}_2 + 2\text{e}^- \longrightarrow 2 \text{Cl}^-$ $\text{SO}_2\text{Cl}_2 + 2\text{e}^- \longrightarrow \text{SO}_2 + 2\text{Cl}^-$ <ul style="list-style-type: none"> • OClS A HAZARDOUS INTERMEDIATE



(A) SPIRAL WOUND CONSTRUCTION¹⁹

(B) BOBBIN CONSTRUCTION 6 & 47

Figure 2-2. Typical Cylindrical Cell Construction Details

Table 2-1. Postulated Reaction Mechanisms for the Reduction of Thionyl Chloride

OVERALL REACTION: $2\text{SOCl}_2 + 4\text{e}^- \longrightarrow \text{S} + \text{SO}_2 + 4\text{Cl}^-$		
I. BOWDEN AND DEY ¹⁴	II. BLOMGREN et al. ¹⁵	III. CARTER et al. ¹⁶
$\text{SOCl}_2 + \text{e}^- \longrightarrow \text{SOCl} + \text{Cl}^-$ $\text{SOCl} + \text{e}^- \longrightarrow \text{SO} + \text{Cl}^-$ $\text{SO} + \text{SOCl}_2 \rightleftharpoons \text{SO} \cdot \text{SOCl}_2$ $\text{SO} \longrightarrow (\text{SO})_x$ $(\text{SO})_x \longrightarrow x \text{S} + x \text{SO}_2$ <ul style="list-style-type: none"> • $(\text{SO})_x$ A HAZARDOUS INTERMEDIATE 	$\text{SOCl}_2 + \text{e}^- \longrightarrow \text{SOCl} + \text{Cl}^-$ $2\text{SOCl} \longrightarrow \text{SO}_2 + \text{SCl}_2$ $\text{SCl}_2 + \text{e}^- \longrightarrow \text{SCl} + \text{Cl}^-$ $2 \text{SCl} \longrightarrow \text{S}_2\text{Cl}_2$ $\text{S}_2\text{Cl}_2 + 2 \text{e}^- \longrightarrow 2\text{S} + 2\text{Cl}^-$ <ul style="list-style-type: none"> • NO APPARENT HAZARDOUS INTERMEDIATE 	$\text{SOCl}_2 + \text{e}^- \longrightarrow \text{OSCl} + \text{Cl}^-$ $\text{OSCl} \longrightarrow \text{OClS}$ $2 \text{OClS} \longrightarrow (\text{OClS})_2$ $(\text{OClS})_2 \longrightarrow \text{SO}_2 + \text{SCl}_2$ $2 \text{SCl}_2 \rightleftharpoons \text{S}_2\text{Cl}_2 + \text{Cl}_2$ $\text{SO}_2 + \text{Cl}_2 \rightleftharpoons \text{SO}_2\text{Cl}_2$ $\text{SCl}_2 + 2\text{e}^- \longrightarrow \text{S} + 2 \text{Cl}^-$ $\text{S}_2\text{Cl}_2 + 2\text{e}^- \longrightarrow 2 \text{S} + 2 \text{Cl}^-$ $\text{Cl}_2 + 2\text{e}^- \longrightarrow 2 \text{Cl}^-$ $\text{SO}_2\text{Cl}_2 + 2\text{e}^- \longrightarrow \text{SO}_2 + 2\text{Cl}^-$ <ul style="list-style-type: none"> • OClS A HAZARDOUS INTERMEDIATE

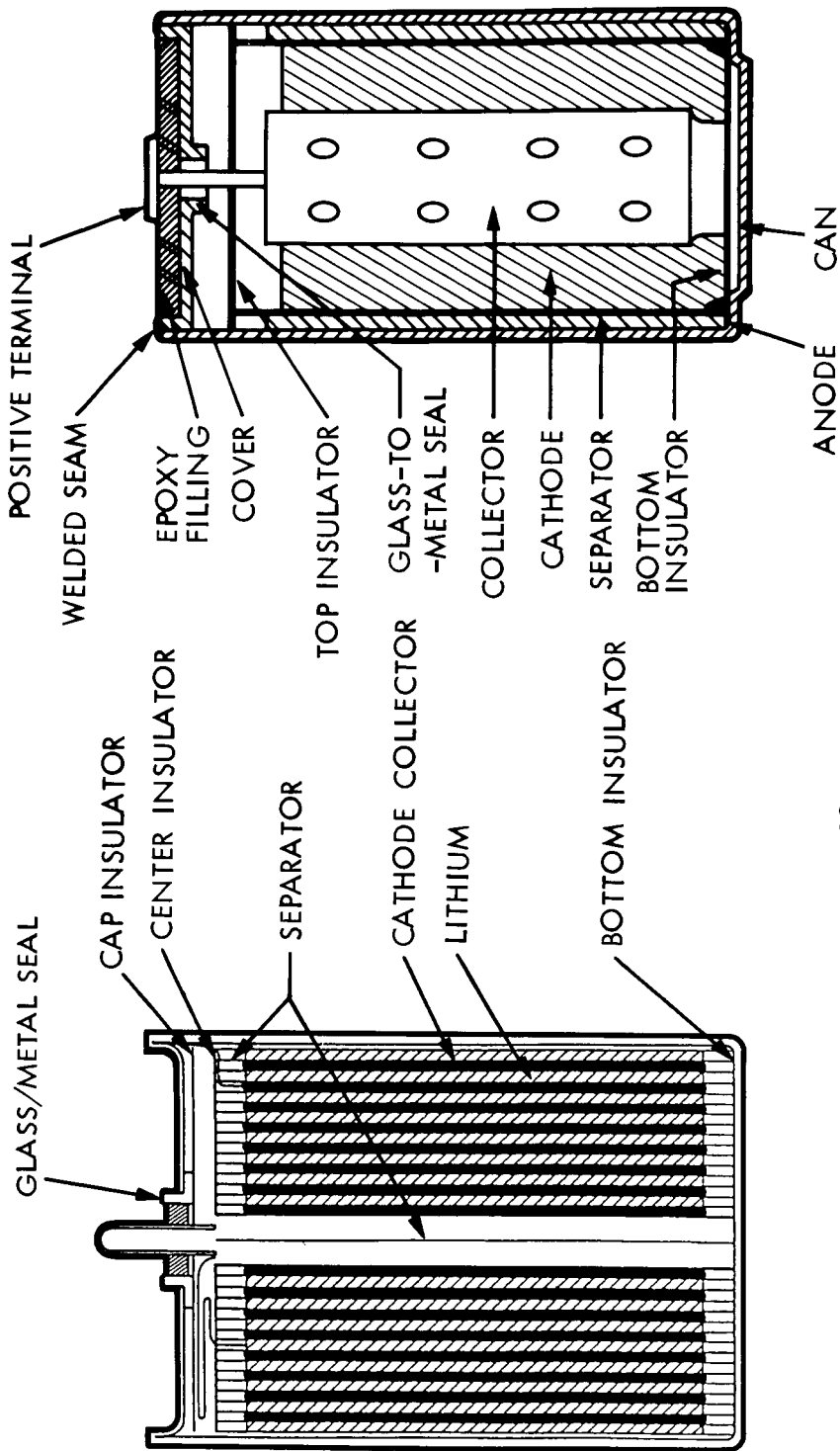

(A) SPIRAL WOUND CONSTRUCTION¹⁹

(B) BOBBIN CONSTRUCTION 6 & 47

Figure 2-2. Typical Cylindrical Cell Construction Details

SECTION 3

RECORDED SAFETY INCIDENTS

A number of incidents are on record involving Li-SOCl₂ cells that resulted in physical damage and one fatal accident. Details of some of these incidents have been reviewed by N. Marincic.¹⁸ These are briefly discussed here for general interest. In August 1976, a 10,000 Ah size Li-SOCl₂ cell (partially discharged) exploded killing one person and injuring at least two others at Hill Air Force Base. A number of cells had been tested and were being prepared for shipment back to the manufacturer when the accident occurred. In another case, a devastating explosion of D-size cells occurred within an oil well logging tool. The power pack consisted of 28 D cells of bobbin-type construction. The tool exploded at room temperature upon the removal of an end plug carrying a spring-loaded fixture that kept the cells together. The investigation of the incident revealed that the cells were less than 50-percent discharged before the accident. All 28 cells blew up, presumably one after another, shredding the housing itself. Similarly, a double D cell exploded during qualification testing for an oil-well logging tool application. The explosion occurred when the cell was heated for testing. In addition to these accidents, many incidents have been reported in the literature; but many of these were due to the deliberate and extreme abuse of the cells undergoing safety evaluation. Unexpected incidents also have occurred that may be related to abnormal operation or improper application of the cells.

SECTION 4

CLASSIFICATION OF HAZARDS AND ANALYSIS OF FACTORS AFFECTING SAFETY

For the most part, all hazardous incidents involving Li-SOCl₂ cells reported to date may be classified into one of the following categories:

1. Leaking of electrolyte (and gases if present) through seals or welds under mild or non-operational conditions.
2. High-pressure venting of internal gases and electrolyte through seal and weld areas.
3. Violent or controlled rupture of a cell case with the expulsion of toxic materials, sometimes explosively with fire.

All of these incidents pose considerable safety problems. The safety problems basically are due to the extreme reactivity and toxic nature of cell components and discharge products. For example, lithium reacts violently with water, which may sometimes result in an explosion. Li and LiOH causes caustic burns to the skin. SOCl₂, SO₂, and SO₂Cl₂ are toxic and, if inhaled, cause serious inflammation of the lung tissue. Thus, the cell components Li, SOCl₂, and LiAlCl₄ and the discharge products are all highly hazardous/toxic materials.

In attempting to analyze the above hazards, one finds it difficult to separate the cause of a violent or controlled rupture from that of venting. Cell rupture may occur when a cell is being operated at a high rate and heat removal is inadequate. Internal pressure increases rapidly with increasing temperature due to both gas expansion and the increase in SOCl₂ vapor pressure. At this point, if a weakness exists in the cell construction (or if a built-in vent exists), venting may occur (category B). Further, as the temperature of the cell rises, new exothermic reactions (e.g., reaction between Li and S) may occur, thus rapidly increasing the temperature even further. If there is no built-in vent or if a weakness in the weld or seal construction exists, the cell may rupture violently (category C). If the cell ingredients are "just right," an explosion with fire may occur. Leaks and/or mild low-pressure venting under normal operation or storage conditions may be attributed to ineffective welds or glass/metal seals (category A).

The basis for all of these incidents may be related to either user-induced or manufacturer-induced causes or both. User-induced causes may be attributed to either operational, abusive, or handling conditions to which the cell is subjected. Manufacturer-induced hazard causes may be related to design and/or quality control deficiencies. After a careful analysis, the sources of the problems cited above have been classified into user- and manufacture-induced categories described in the block diagram (Figure 4-1).

Factors affecting safety are described in detail in Section 5 (user-induced factors) and Section 6 (manufacturer-induced factors) along with suggested solutions and conditions for their safe use.

ORIGINAL PAGE IS
OF POOR QUALITY

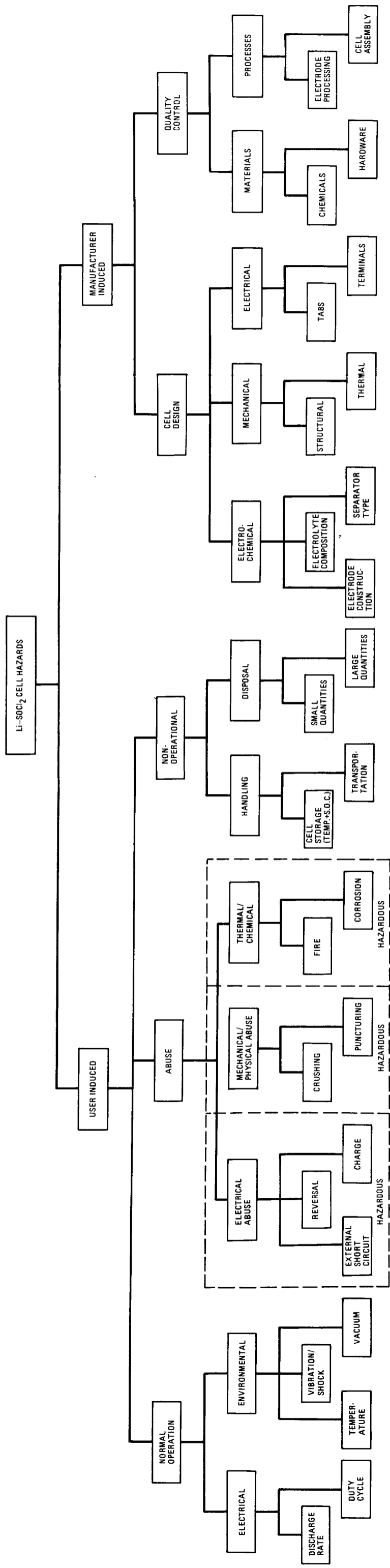

2 FOLDDOUT FRAME

Figure 4-1. Classification of the Factors Responsible for the Unsafe Behavior of Li-SOCl₂ Cells

1 FOLDDOUT FRAME

PRECEDING PAGE BLANK NOT FILMED

SECTION 5

USER-INDUCED FACTORS

The user may induce hazards during normal cell operation if the discharge rate or duty cycle is excessive or if environmental conditions (e.g., temperature, vibration, and shock) exceed the cell design capability. Hazards may also be induced by electrical abuse, (e.g., shorting, reversal, and/or charging) mechanical abuse, (e.g., puncturing, crushing, or impact), or by thermal/chemical abuse (e.g., fire, corrosion, etc.). Finally, the user may abuse a cell by uncontrolled storage, improper transportation, or disposal. Normal operation is generally safe. However, a lack of knowledge or understanding of safety issues may lead to problems.

Environmental test conditions may cause hazards if the cell is not designed to handle the required shock and vibration experienced in space-flight. An adequate safe design should meet all launch requirements. Li-SOCl₂ cells are capable of long-term storage over a wide range of temperatures. An unusually high temperature excursion (>80°C) during storage could affect performance and may also result in venting.

Abuse is probably the most prevalent Li-SOCl₂ cell hazard. Electrical abuse testing is purposely performed on cells to determine how the cell will respond to a short circuit, forced over-discharge, or charge. Test severity is generally well beyond that seen in actual use and is used to determine safe operational envelopes. Abuse tests are performed mainly to determine what will happen when the cells are inadvertently subjected to abuse. Examples of unexpected abuse include the use of these cells in equipment for which cells of other electrochemistries (eg HgO/Zn) were designed or deficiencies in the electrical equipment planned that permit the cells to be reversed, charged, or shorted.

Other abuse conditions are mechanical or physical in nature and include crushing, puncturing, or mishandling, such as placing the cells on a metal bench and/or dropping a heavy piece of equipment or nail across the cell terminals. These conditions are usually brought about by untrained personnel who are unaware of the high energy content and safety concern for these cells. Disposal of these cells, especially in a discharged or partially discharged condition, requires careful, although not necessarily unusual handling.

Many explanations have been offered to explain the unsafe behavior of the cells under the above operating and abuse conditions. The explanations fall into two categories: 1) thermal mechanisms and 2) chemical mechanisms. However, it is quite difficult to separate the effect of each. The impact of both may be responsible for cell venting or explosion.

The influence of these user-induced abuse parameters are discussed in detail in this section together with suggested solutions.

5.1 NORMAL OPERATION

A cell/battery may be considered for use only when it can be operated safely under all normal operating conditions/requirements. In general, Li-SOCl₂ cells perform safely at low discharge rates. However, when the cells are discharged at higher rates than recommended by the manufacturer, they may vent or explode depending on cell design and/or discharge rate.⁷ Cells also have exhibited abnormal behavior when subjected to environmental conditions (e.g., temperature, vibration, and shock) exceeding their operational design capability. The influence of various normal operational conditions (electrical and environmental) on cell safety is discussed in subsections 5.1.1 and 5.1.2.

5.1.1 Electrical

5.1.1.1 Discharge Rate. The rate of discharge is a significant factor in the safety of Li-SOCl₂ cells. It also plays an important part in performance as well. The discharge voltage and cell capacity decrease with an increase in the discharge rate¹⁹ (Figure 5-1).

The influence of the discharge rate on safety is given in Figure 5-2. The discharge rate becomes a safety factor because heat is produced during discharge due to polarization; thus, the higher the discharge current the greater the quantity of heat produced in the cell. The greater the quantity of heat, the more difficult it is for the heat to be transferred away from the electrode stack. At low to moderate rates of discharge ($<C/10$), cells are relatively safe because the rate is low enough to allow the heat generated by the exothermic reactions to be absorbed or transferred to the surroundings with little temperature increase in the cell or its components. At discharge rates above the $C/3$ rate, cells undergo physical deformation, vent toxic gases, and/or explode violently under certain conditions.²⁰ A D-size cell (10-15 Ah capacity) of jellyroll configuration, when discharged at 10 amps (C rate), explodes after 28 minutes.²⁰ A cell short can cause the most severe safety problem (see subsection 5.2.1.1).

Many explanations have been offered to account for venting and explosion of the cells during discharge. They may be classified into three categories: 1) overpressurization, 2) thermal runaway, and 3) hazardous intermediates formation. These categories are discussed below in detail.

1) Overpressurization. The possibility of venting of the cells due to overpressurization was examined in detail.^{21,22} Many sources of gas may contribute to the increase in pressure in Li-SOCl₂ cells. Sources include (a) SO₂ evolved during discharge, (b) SOCl₂ vapor, (c) gases trapped by absorption in the carbon electrode and released as insoluble discharge products are deposited, (d) N₂ released from the lithium anode during discharge, (e) hydrogen produced from the reduction of hydrolysis products and other protic species, and (f) gaseous products created by the reactions carbon and sulfur and carbon and SO₂. Among the possible gas generation mechanisms of pressurization, the electrochemical generation of SO₂ on discharge and the increase in SOCl₂ vapor pressure play major roles in pressure buildup. The

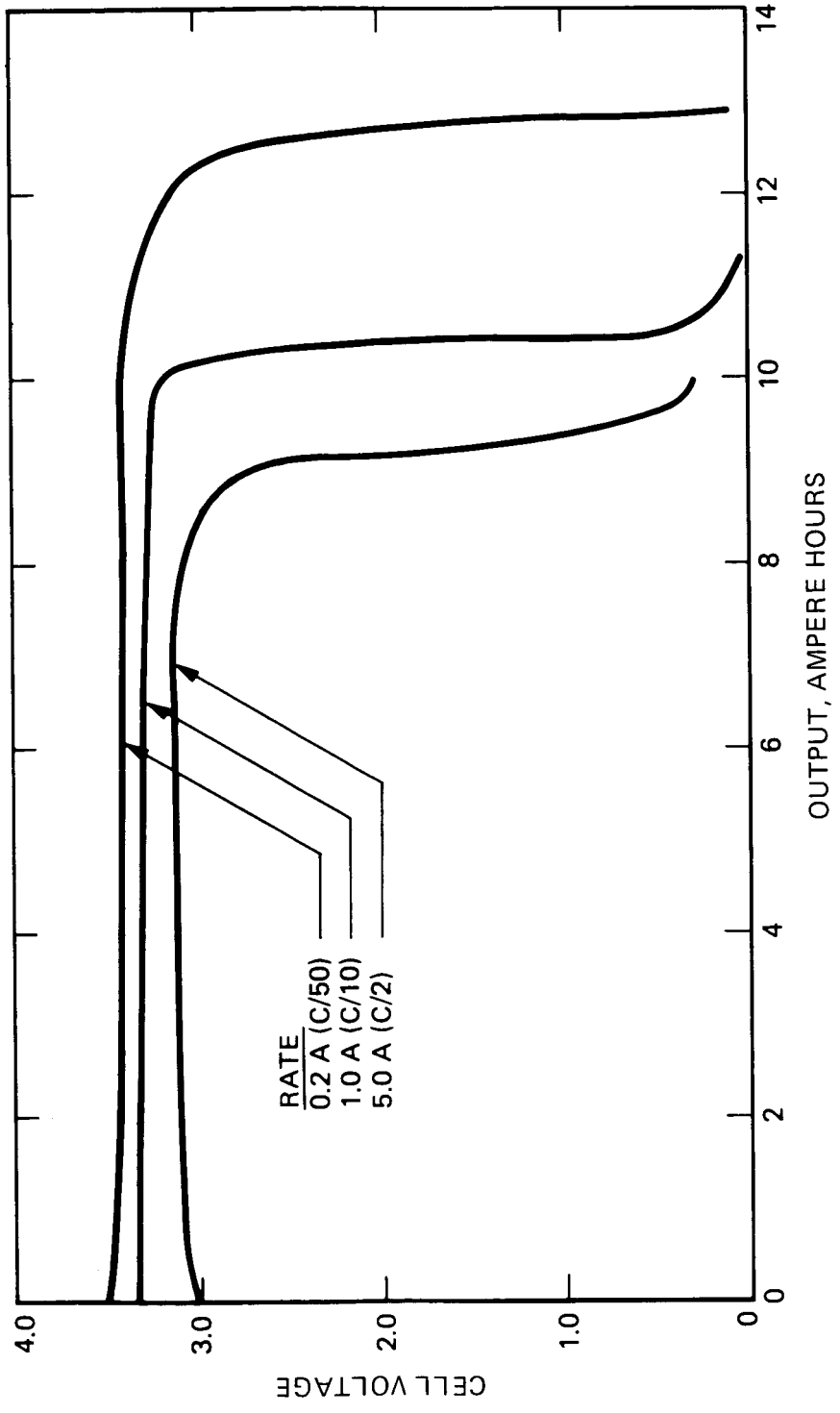
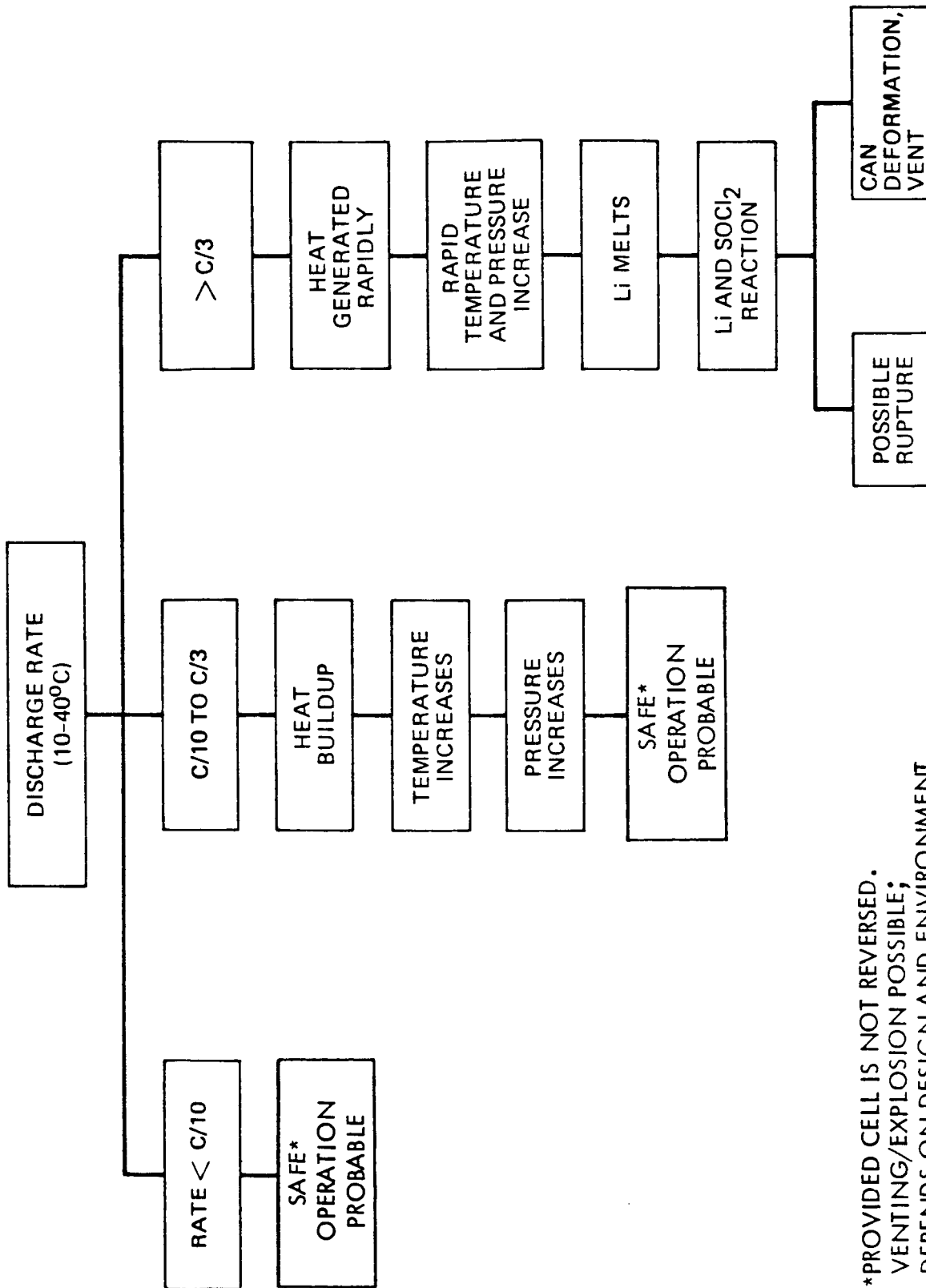

Figure 5-1. Effect of Discharge Rate on Li-SOCl₂ Cell Performance¹⁹



*PROVIDED CELL IS NOT REVERSED.
VENTING/EXPLOSION POSSIBLE;
DEPENDS ON DESIGN AND ENVIRONMENT.

Figure 5-2. Influence of Discharge Rate on Li-SOCl₂ Cell Safety

pressure build-up in the cells is minimal at low to moderate rates of discharge. Heating of the cell whether by high rates of discharge or by an external heat source or adiabatic condition also reduces SO₂ solubility in the electrolyte and further increases internal pressure. In such an event, the increased cell internal pressure leads to internal stress of the case, cover, and seal; thus some deformation of the cell case is possible. If there is a built-in vent, it can be activated as the pressure gets beyond its design limit. Without the vent release mechanism in the case or seal, the pressure can be relieved only by high-pressure venting through the weakest points in the weld or seal.

2) Thermal Runaway. Thermal runaway may occur when an excessively high discharge rate causes a large quantity of internal heat to be generated in the cell and the cell is unable to dissipate the heat to the surroundings fast enough. The temperature buildup may initiate exothermic reactions that would not normally occur. These new exothermic reactions add a significant quantity of heat to the system in addition to heat produced by normal discharge reactions. The new products formed and the higher temperature may result in unsafe conditions. As a minimum, the cell will vent its products through the welds or seal. Under extreme conditions (e.g., cell short) the temperature of the reaction may increase at a very high rate, producing a situation that may be violent enough to result in an explosion, possibly with fire.

Heat generation at various discharge rates was examined theoretically by N. Marincic et al.,²³ H.A. Frank,^{24a} and Young I. Cho et al.^{24b} in detail. N. Marincic calculated that a D-size cell would explode in 23 minutes if it were discharged at 10 amps. In practice it was found to explode after 28 minutes²⁰. H.A. Frank reported that the experimentally determined heat was slightly greater than the theoretically calculated heat (Figure 5-3). The difference between the two was attributed to heat from the chemical reactions. An empirical formula was used to calculate heat evolved during normal discharge:

$$Q = I (3.7 - E.op)$$

In this equation, Q is the heat output in watts, I is the operating current in amps, and E.op is the operating voltage.

The results of the studies indicate that temperatures higher than 180°C may result if the cells are discharged at rates higher than C/3 under adiabatic conditions.²⁴ At low to moderate discharge rates (<C/10), cells may reach 80°C at the end of discharge at room temperature.

Young I. Cho et al.^{24b} investigated the heat flow paths in cylindrical D-size, spirally wound Li-SOCl₂ cells. The studies indicate that 89 percent of the heat flows normally to the electrodes, separator, and side wall case can. The remaining 11 percent of the heat flows axially to the electrodes and arrives at the bottom wall of the cell. Tabs have a high thermal resistance, and heat flow through them is not possible.

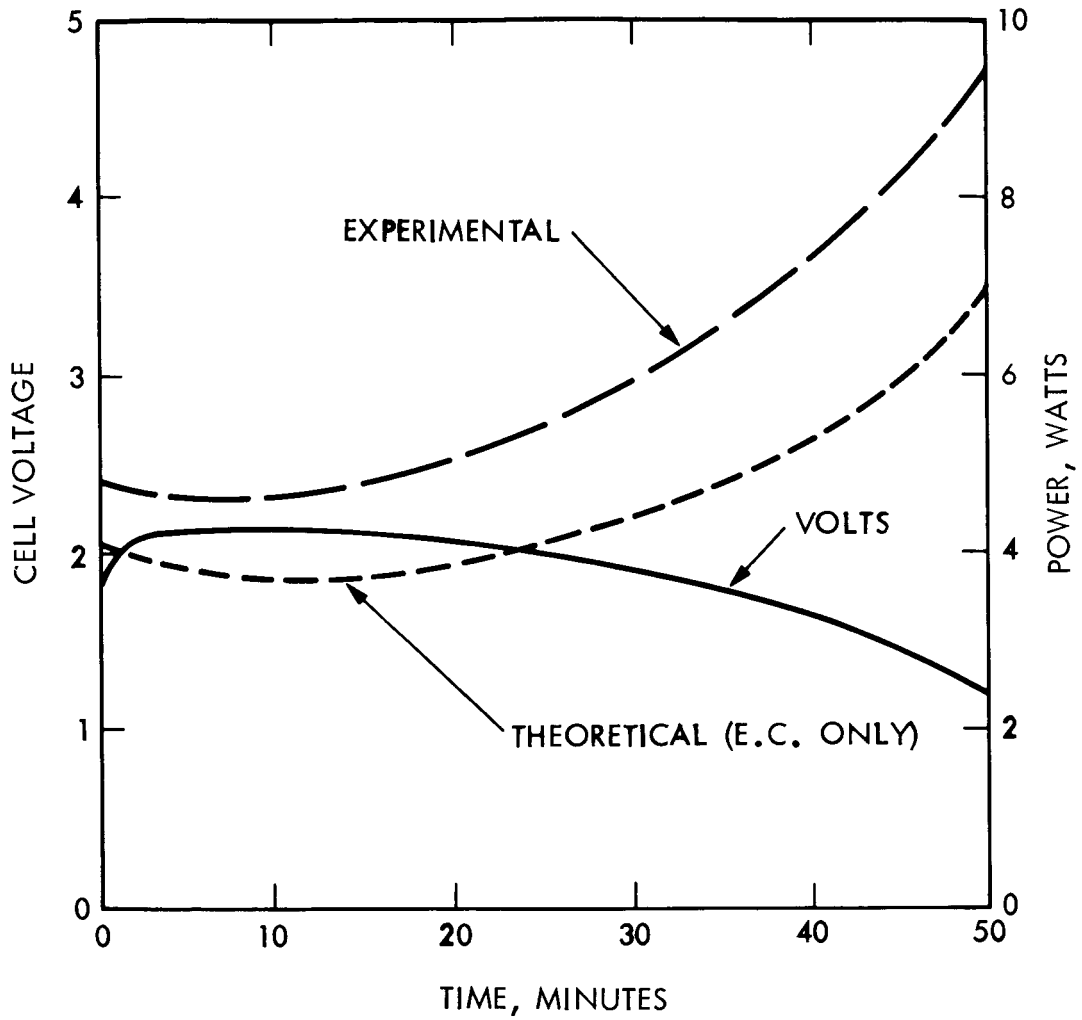

Figure 5-3. Heat Generation During Discharge of a Li-SOCl₂ Cell⁽²⁴⁾

The wall structures and finishes of the cell have been identified as important factors in heat dissipation. It has also been demonstrated that thermal resistances may be used to estimate the maximum allowable heat generation within the cell, which is found to be 2.8 w; i.e., C/2.2 discharge rate for a D-size, spirally wound cell.

Reactions that could lead to thermal runaway of the cells were examined in detail by A.N. Dey,²⁵ D.L. Chua et al.,²⁶ and S. Dallek et al.²⁷ by DTA/DSC methods. Major conclusions from these studies were that:

- (1) None of the materials (Li, SOCl₂, and LiAlCl₄), either by themselves or in combination with any of the others, exhibit exotherms below 335°C. The Li-SOCl₂-LiAlCl₄ mixture is reactive over a wide range of temperatures, well above the melting point of Li (180.54°C)*.
- (2) No exothermic reaction can take place between Li and S in the presence of SOCl₂ at temperatures below 395°C. However, in the absence of SOCl₂, Li reacts exothermically with S at approximately 170°C.
- (3) No low-temperature exotherms were observed between starting materials (Li, SOCl₂, and LiAlCl₄) and other suspected products (Li₂S, Li₂SO₄, SO₂, Cl₂, and LiCl).
- (4) Lithium forms exothermic couples with the cathode mix and glass at high temperatures of 429°C and 587°C, respectively.
- (5) Lithium nitride and Li₂S were found to have exothermic reactions with SOCl₂ but at a temperature well over 300°C.
- (6) The presence of carbon black converts the inert Li-SOCl₂-LiAlCl₄ mixture into one that is highly reactive. This combination of materials was found to exhibit exotherms at temperatures as low as 40°C-50°C. This is understandable if one assumes that a local reactive cell is formed that activates the Li and SOCl₂ reaction. Carbon's function is to provide a catalytically active surface at which SOCl₂ can be reduced.
- (7) Exothermic temperatures and magnitudes of heat produced were comparable for pure Li and some Li alloys.

It should be noted that the reactive mass ratios and the heat transfer conditions in the differential thermal analysis/differential scanning calorimetry (DTA/DSC) experiments differ widely from those obtaining in actual cells. Therefore, these conclusions do not necessarily reflect actual cell behavior.

*Handbook of Chemistry and Physics 64th Edition.

There is a belief that at a temperature of about 112°C, lithium reacts violently with the sulfur formed on discharge. These studies clearly contradict this belief. Apparently the liquid SOCl₂ maintains a film on Li that inhibits the reaction. From this it can be inferred that flooded cells are safer than electrolyte-starved cells.

Molten lithium also may react with SOCl₂, which may lead to a hazardous condition (when there is inadequate thermal dissipation). Therefore, with a properly designed and used cell (adequate electrolyte and thermal dissipation), thermal runaway can be avoided. Thermal studies conducted on a fully discharged cell⁹ compared to a fresh cell indicated exothermic peaks at 92°C, 103°C, and 148°C. When the experiment was repeated on the same cell, no such peaks were observed. No explanation has been offered for the observed exotherms in the first study. Some of these exotherms may be due to a reaction between lithium and sulphur.

3) Hazardous Intermediates. The unsafe behavior of Li-SOCl₂ cells during discharge is also believed to be due to the production of and the violent decomposition of intermediates formed. The concentration of metastable compounds can increase to a point that their decomposition causes venting or an explosion or produces sufficient heat to trigger exothermic reactions. Detailed research has been undertaken by many R&D groups, especially at JPL, to determine the role of intermediates in the safety of these cells.^{13-16,28-33} Several intermediates were postulated in the reduction of SOCl₂ such as SO, (SO)_x, S₂O, S₂Cl₂, SCl₂ OClS and (OClS)₂ and Li₂O₂. Among these intermediates, only SO, (SO)_x, Li₂O₂, OClS, and (OClS)₂ were suggested to pose hazards. No firm evidence exists for the presence of SO and (SO)₂, and hence their role in determining the cell safety is questionable.³¹ Additional research is required to confirm or refute the existence of Li₂O₂.

The presence of OClS was reported based on ESR studies.^{16,31} This compound could be a hazardous intermediate, by analogy with the chemistry of ClO₂, if present in sufficiently high concentration. However, the lack of delay in the formation of SO₂ observed by Isotone and Brodd³⁰ and the relatively short lifetime of OClS and (OClS)₂ suggests that the concentration of OClS never gets high at 25-30°C. Hence OClS may not be a problem for discharges in this temperature range. Further work is needed to determine the role of these intermediates in the safety of Li-SOCl₂ cells.

Suggested Improvements. From the above discussions it is clear that the safety problems caused by the undesirable reactions and pressure buildup during discharge are due mainly to excessive heat generation within the cell coupled with inefficient heat transfer from the cell because of poor thermal design. The higher the discharge rate, the greater the concern for cell safety (Figure 5-2). Hence any approach that can reduce cell polarization and exothermic reactions during discharge and permit effective heat transfer should result in enhancement of cell safety and performance. Even though considerable research has been done in determining the role of intermediates on cell safety, a complete understanding has not yet fully emerged. Clearly more work is needed to fully understand the effect of the intermediates on the safety of Li-SOCl₂ cells.

The various approaches that have been reported in the literature to minimize safety problems include:

- (1) Using multiple tabs on the electrodes to minimize uneven current distribution.^{7,34}
- (2) Using high-purity materials and ensure that Li is not contaminated with Li_3N .²⁷
- (3) Equipping high-rate cells with fuses (thermal, if possible) to limit the current to a safe value.^{35,36}
- (4) Equipping cells with a mechanical vent to permit the escape of gases/electrolyte in the event of overpressurization of the cell.^{37,38} (This depends on whether the application will allow the release of gas to the environment.)
- (5) Reducing the rate capability of the cells by reducing the surface area of the electrodes.³⁹
- (6) Using excess electrolyte to sustain conductivity until the end of discharge and preferably even during reversal.⁴⁰
- (7) Using electrolytes with improved conductivity.⁴¹
- (8) Designing cells taking into consideration all thermal parameters.⁴²
- (9) Keeping the electrolyte and other cell parts free from the atmosphere.¹¹

To the extent to which they have been applied to date, these approaches have resulted only in marginal enhancement of the safety of Li-SOCl_2 cells. Use of excess electrolyte will reduce heat generation at the end of discharge and during reversal. More work is needed to improve the conductivity of the electrolyte. Even though the importance of heat management in the cell design has been recognized, effective solutions have yet to be implemented in these neutral electrolyte cells.

5.1.1.2 Duty Cycle. The duty cycle also may affect cell safety. For the most part, if there is a high-current discharge requirement, a pulse rather than continuous discharge will minimize the temperature level. The rest time will allow the heat to be radiated or conducted away from the cell. The greater the percentage of time the load is off, the greater the time for the heat to dissipate. Therefore, interruption of the load can improve safety.

5.1.2 Environment

Temperature, vibration, shock, and vacuum are environmental conditions that may affect safety and performance of Li-SOCl₂ cells. These conditions are discussed below.

5.1.2.1 Temperature. Temperature has a considerable effect on the discharge performance, storage properties, and safety of Li-SOCl₂ cells. Cell capacity discharge voltage and rate capability decrease as the temperature is lowered⁴³ (Figure 5-4). At temperatures lower than -20°C, cell capacity falls quite rapidly. The cut-off temperature is reported to be between -70°C and -80°C where the cell loses its electrochemical performance totally.⁴⁴ B.J. Carter et al. reported^{16,31} that OClS might form in sufficiently high concentrations at lower temperatures, and in view of this they have expressed concern regarding the safe operation of cells at very low temperatures. An overview of the influence of temperature on cell safety is given in Figure 5-5.

Explosions at elevated temperatures are believed to be due to simple pressurization²¹ or thermal runaway.^{25,26,27} These were discussed in subsection 5.1.1, as influenced by the discharge rate. GTE reported that the pressure of a sealed fresh cell increased from 14 to 28 psi as the temperature was raised from 25°C to 70°C.²¹ By calculation, it has been shown that appreciable pressure can result in discharged cells that are at ambient to moderate temperatures (25°C to 80°C). In addition to the decreased solubility of SO₂ and the increase in vapor pressure of SOCl₂, very high pressures may result in discharged cells at temperatures between 80°C to 180°C. The reaction between sulfur and thionyl chloride may be responsible for pressure build-up at temperatures of 130°C and above in partially or fully discharged cells. At 180°C, the melting point of lithium, the total pressure within the cell is estimated to be greater than 200 psi. The cylindrical cell configuration now in use is able to survive higher pressures without rupturing.

Thermal runaway may occur in partially and fully discharged cells having limited electrolyte. Exothermic reactions may take place between Li and sulfur^{21,23} in cells under these conditions. In flooded cells at temperatures above 180°C, lithium may melt and react with SOCl₂ over the carbon electrode surface or directly.²⁴ These exothermic reactions may initiate thermal runaway of the cell.

In summary, at high temperatures and high rates, gas expansion and pressure increase are possible, and only a well-designed and structurally sound cell may avoid venting. At temperatures of about 120°C, S in the electrolyte may react with SOCl₂ to form SO₂ and S₂Cl₂, which may further increase cell pressure. More violent venting may also be expected under this condition, and at internal temperatures well above 120°C, cells may explode, particularly if cell internal temperature exceeds 180°C.

Suggested Improvements. To minimize the hazardous behavior of Li-SOCl₂ cells, the following recommendations have been suggested in the literature:

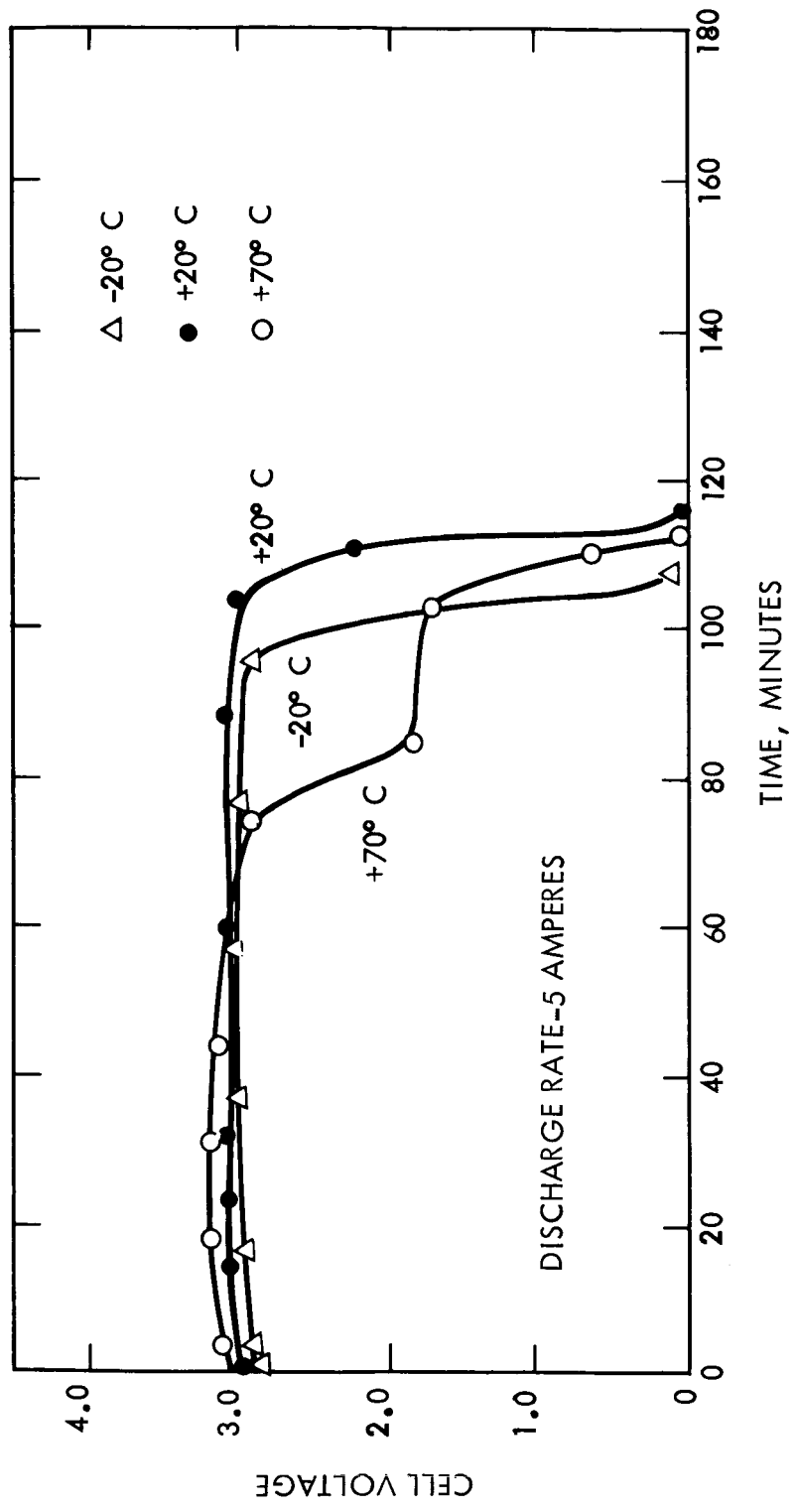
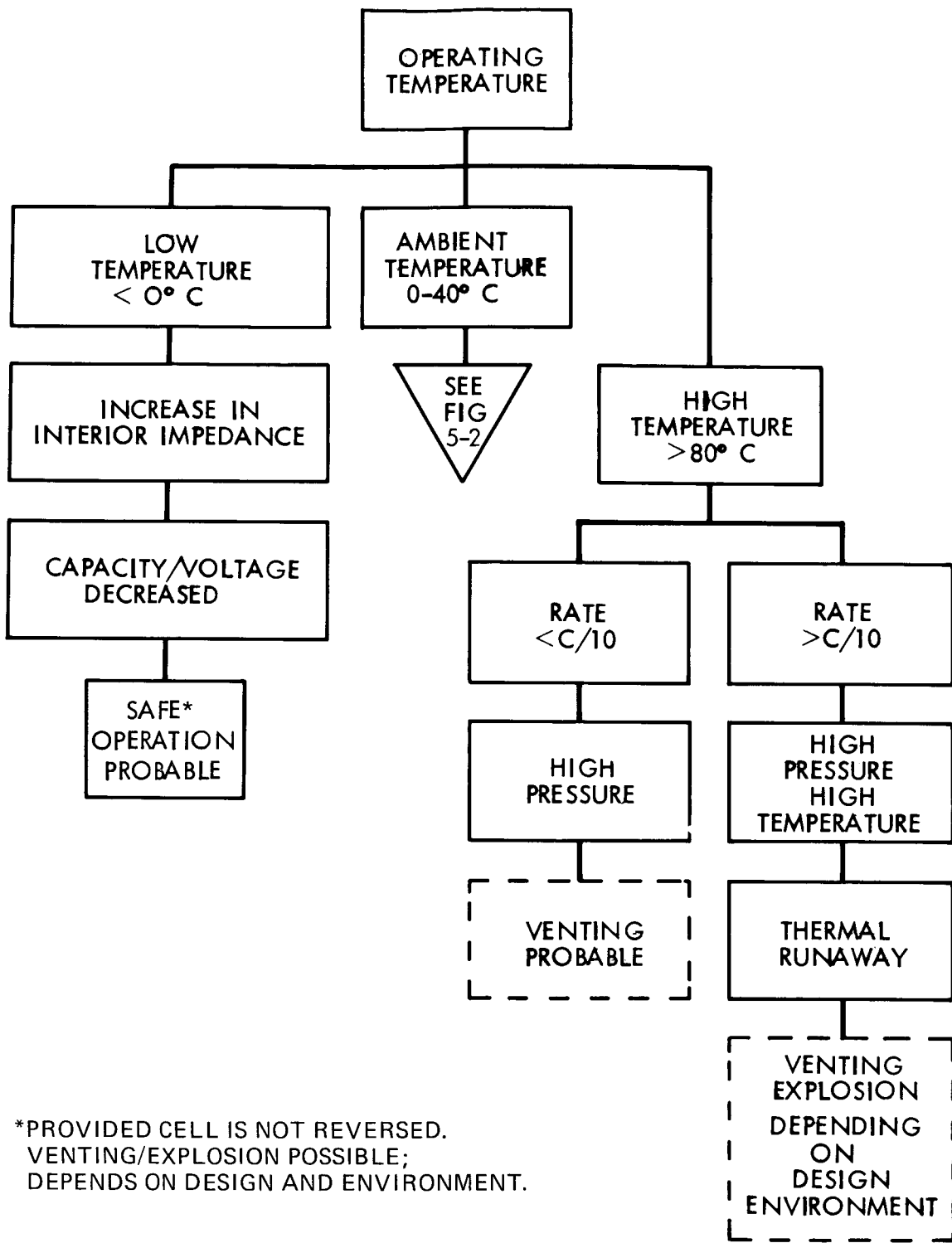

Figure 5-4. Effect of Temperature on Li-SOCl₂ Cell Performance⁴³



*PROVIDED CELL IS NOT REVERSED.
 VENTING/EXPLOSION POSSIBLE;
 DEPENDS ON DESIGN AND ENVIRONMENT.

Figure 5-5. Influence of Temperature on Li-SOCl₂ Cell Safety

- (1) Operate or store the cells below 80°C.
- (2) Provide suitable and reliable vent mechanisms.^{37,38}
- (3) Equip the cells with glass/metal or glass/ceramic seals.

5.1.2.2 Vibration and shock. Batteries in general are sensitive to vibration and shock. These environments may cause cracks in the electrodes, which are porous and brittle, and this may result in cell shorting. The tabs may also break due to these factors, and in such cases the cells may become open circuited. The passive film present on the Li electrode may also disintegrate if the cells are subjected to very high shock or impact loads.

A great deal of work has been done to study the effect of these environments on the safety of Li-SOCl₂ cells.⁴⁵⁻⁴⁸ Fresh or partially discharged cells have been reported to withstand these environments without any hazard. N. Marincic and F. Goebel⁴⁵ subjected partially discharged cells (10,000 Ah) to 100 g. shocks along each of 3 axes and vibrations of 5 Hz-2000 Hz frequencies at a peak of 2 g. without any incident. K.F. Garoutte and D.L. Chua⁴⁶ subjected two 16,500 Ah cells to drop tests without any significant hazard. M. Babai⁴⁷ subjected AA, C, and D cells to extensive environmental tests according to MIL-STD-810C. J. Epstein and N. Marincic⁴⁸ reported an incident of explosion of low-rate type Li-SOCl₂ cells on impact. They attributed this to a manufacturing defect. However, the observation has the far reaching implication that improperly constructed or designed cells may be explosion prone under the stress of high vibration, shock, and impact. Fully discharged cells and batteries that have undergone reversal are reported to be shock sensitive.⁷

It is also possible that shock and vibration affect the integrity of the glass/metal seal, either by separation from the terminal or case or cracking the glass directly. Either condition allows gas leakage and electrolyte leakage. Hence, the cell and its components must be designed to meet the required levels of environmental testing. Further, without a safe design, cell hazards can occur.

5.1.2.3 Vacuum. Not much work has been reported on the safety evaluation of cells under a vacuum. However, cells with crimp seals are thought to be unsuitable for operation under a vacuum. Securing the case cover by tungsten/inert gas (TIG) welding or other means is the recommended method, and the use of reliable glass/metal seals is required.

A vacuum environment may affect heat management of cells and batteries. Heat removal is more difficult in a vacuum; and, therefore, greater provisions have to be made to conduct heat away from cells operating in a vacuum.

5.2 ABUSE

The various abuses that a cell/battery may undergo are classified broadly into three categories: 1) electrical, 2) mechanical, and 3) thermal. Short circuit, forced over-discharge (reversal), and charging are the main examples of electrical abuse. Mechanical/physical abuse consists of crushing, puncturing, and piercing. Subjecting the cells to fire/incineration is considered thermal abuse. These are shown in Figure 4-1.

Abuses may be inadvertent or deliberate. All of the former may occur because of a lack of knowledge of equipment design, lack of training on the part of the user, poor electrical or mechanical design in the electronic components or equipment with which it is associated, or inconsistencies/deficiencies of the cell and/or battery performance.

Deliberate abuses are those that manufacturers and users have given the cells in order to evaluate their safety. These are the same type of activities described above except that they are performed to learn the safety limits of the cells. This information is useful in improving cell design, battery design, or electronic equipment. However, this type of abusive testing should be properly understood. Any type of electrochemical cell may be made to vent, explode, or become unsafe if conditions are abusive enough. Therefore, it is essential that the information be used to alert users regarding cell safety limits and to label it safe only with appropriate caveats.

The various types of abuse and their implications will be discussed in the following paragraphs. The objective is to alert the user of the abuse, its cause, and dangers and the magnitude of the problem.

5.2.1 Electrical Abuse

5.2.1.1 Short Circuit. The term short circuit generally means electrical contact between the anode and cathode of a cell. This problem is the extreme case of high-rate discharge and thus is a serious concern. High-rate discharge was discussed in detail in subsection 5.1.1.1. However, because it is considered an abuse, it is discussed here in a different context. The short circuit may be either external or internal. Problems associated with external short circuits are considered here as they are mainly user-induced. The internal short is considered a manufacturer-induced problem and is discussed later in this report.

External shorting of Li-SOCl_2 cells is a serious safety concern. The safety problems upon short-circuit are essentially due to thermally induced chemical reactions (thermal runaway) initiated by large I^2R losses within the cell. The extent of the consequences depends significantly on the nature of the short and cell type.^{7,39,47} If the resistance of the short and resulting discharge current are within the design rate capability of the cell, the cell will discharge safely. However, if the resistance of the short is quite low and the current exceeds the rate at which the cell can safely operate, it can deform, vent, or explode. A spirally wound D cell may explode

upon short circuit within 10 minutes.⁷ An example of the cell characteristics during an external short circuit is given in Figure 5-6.

The poor electrical conductivity of the electrolyte, the exothermic reactions between the electrode materials and the discharge products, and the low melting point of the Li are responsible for the unsafe behavior of Li-SOCl₂ cells under short circuit. The electrolyte has a specific conductivity, which is typically 4 orders of magnitude less than carbon black and 7 to 8 orders of magnitude lower than metals such as nickel and lithium.¹ Thus, the high resistivity of the electrolyte accounts for most of the general heating during high rates of discharge and short circuit. If the heat produced within the cell due to external shorting is considerable and the heat is not dissipated effectively, it may lead to the melting of lithium in the electrode. Once the lithium melts, the passive LiCl film breaks, and the lithium may react violently with the SOCl₂ at the carbon electrode surface. This may lead to an explosion of the cells or venting of toxic gases.^{7,27} An overview of the influence of short circuit of the safety of the cells is given in Figure 5-7.

Suggested Improvements. A number of suggestions have been reported in the literature aimed at making the cells relatively safe under short-circuit conditions. These various measures include:

- (1) Modifying the Li electrode by alloying it with elements such as boron, calcium, magnesium, silicon, aluminum, etc. to increase the melting point of the anode material.⁴⁹
- (2) Using various electrolyte salts to improve electrolyte conductivity.^{41,50}
- (3) Limiting the short-circuit current by limiting the surface area of the electrodes (as in bobbin-type cells).^{39,47}
- (4) Providing cells with suitable mechanical pressure release vents to allow gases and electrolyte to escape from the cell when overheating takes place.^{37,38}
- (5) Providing each cell with a current limiting fuse or similar device.^{35,36}

No significant improvements in safety have been observed by alloying lithium with boron or other elements. Similarly, the use of other electrolyte salts has not made the cells safer. Limiting the electrode area has been found effective in reducing hazards associated with short-circuiting. However, these measures have resulted in decreasing the rated performance of the cells. Dey has suggested that D-size cells of jellyroll configuration can be made safe by reducing the electrode length to less than 7 inches.³⁹ Providing the cells with a vent would minimize explosions; however, the premature failure of vents could limit the usage of these cells. At present, the recommended solution to make the cells relatively safe is to provide each cell with a current limiting fuse or similar device.

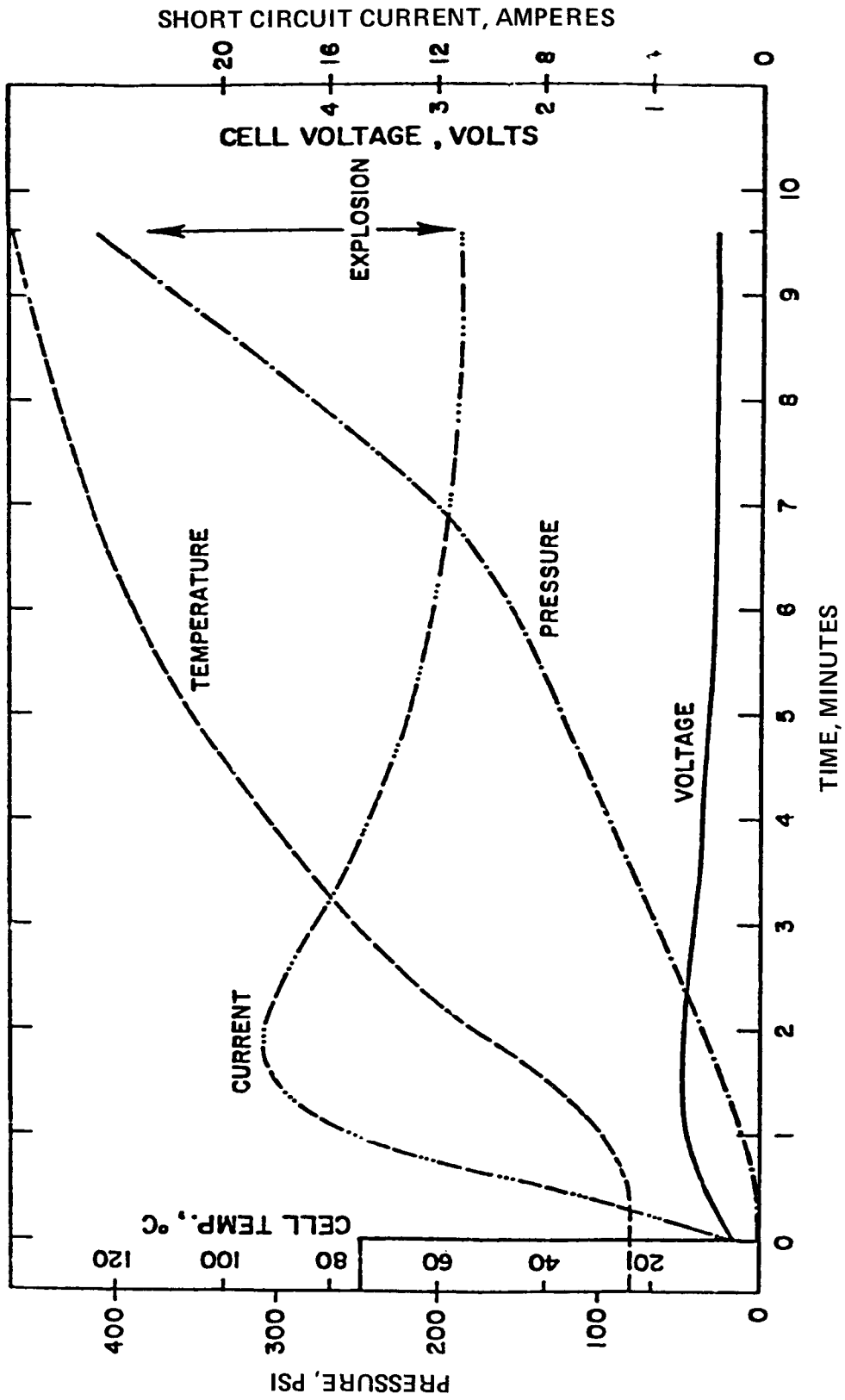
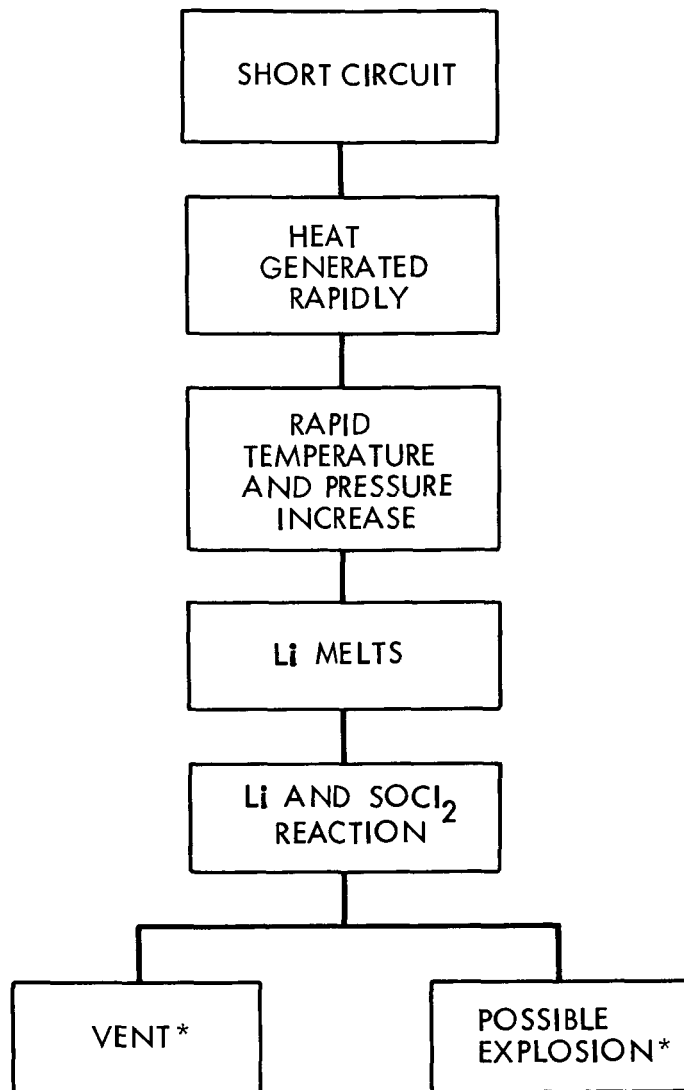

Figure 5-6. Pressure, Temperature, Voltage, and Current During Li-SOCl₂ Cell Shorting



*DEPENDS UPON DESIGN AND ENVIRONMENT.

Figure 5-7. Influence of Short Circuit on Li-SOCl₂ Cell Safety

5.2.1.2 Forced Over-Discharge (Reversal). During discharge, a cell in a series battery can be forced into voltage reversal by the other cells in the same series string if its capacity is exhausted prematurely (compared to the others in the string). In such an event, current is forced through the cell driving the voltage negative and thus causing abnormal reactions to occur. Forced over-discharge of any electrochemical cell may result in an unsafe condition. This is particularly true in the case of Li-SOCl₂ cells, which have been found to exhibit unpredictable behavior under this condition. Some cells have been reversed without any incident, while others were found to vent toxic gases or exhibit violent rupture.^{7,51,52,53} An example of the characteristics of a cell forced into reversal is given in Figure 5-8. In certain other instances, cells were found to become shock sensitive after undergoing reversal and sitting on open circuit for long periods of time, thus adding handling and disposal to the conditions for caution.

Current flowing through a cell during forced over-discharge has been reported to initiate new chemical reactions resulting in the formation of highly reactive species. These new species themselves or subsequent chemical reactions initiated by them have been suspected for the unsafe behavior of these cells. It has been determined that the nature of the reaction taking place during reversal is dependent on cell design; i.e., whether cell capacity is limited by (1) clogging of the carbon electrode (carbon limited), (2) lithium availability (anode limited), or (3) thionyl chloride availability (catholyte/solvent limited). A discussion of the safety-related issues of the three types of cells follows.

The influence of cell reversal on safety is shown in Figure 5-9. Results of various investigations conducted thus far on this subject are summarized below. The reactions and results are different for the three cases as given in the overview in Table 5-1.

1) Carbon-Limited Cells. In carbon-limited cells, useful cell life ends with carbon electrode passivation caused by the plugging of its pores with insoluble discharge products.⁵³ Figure 5-10 gives the discharge and over-discharge characteristics of a typical carbon-limited cell. Figure 5-10 shows that the the end of cell life is limited by the carbon electrode (the Li electrode potential remains constant throughout the entire the discharge). Upon continuing discharge, the cathode is forced to more negative voltages than the anode, and a cell voltage on the order of -100 mv results. The chemical reactions taking place during carbon-limited voltage reversal (CLVR) were investigated by K.M. Abraham et al.,^{54,55} A.I. Attia³², B.J. Carter et al.,⁵⁶ S. Subbarao et al.,⁵⁷ and F.W. Dampier et al.⁵⁸ in detail. Presently, it is believed that during reversal, the major process occurring at the anode is lithium electrostripping, while the major process occurring at the cathode is lithium electrodeposition.

Formation of sensitive compounds and intermediates during CLVR was examined by various electrochemical and spectroscopic techniques. No new species (other than those seen during normal discharge) were observed.⁵⁶ LiCl is the major product identified in the carbon electrodes.⁵³⁻⁵⁷ The presence of Li₂O, Li₂S, Li, Li₂S₂O₄ or Li-C intercalates, which were suspected in the carbon electrodes, were not observed in the X-ray data.³³ However, McDonald

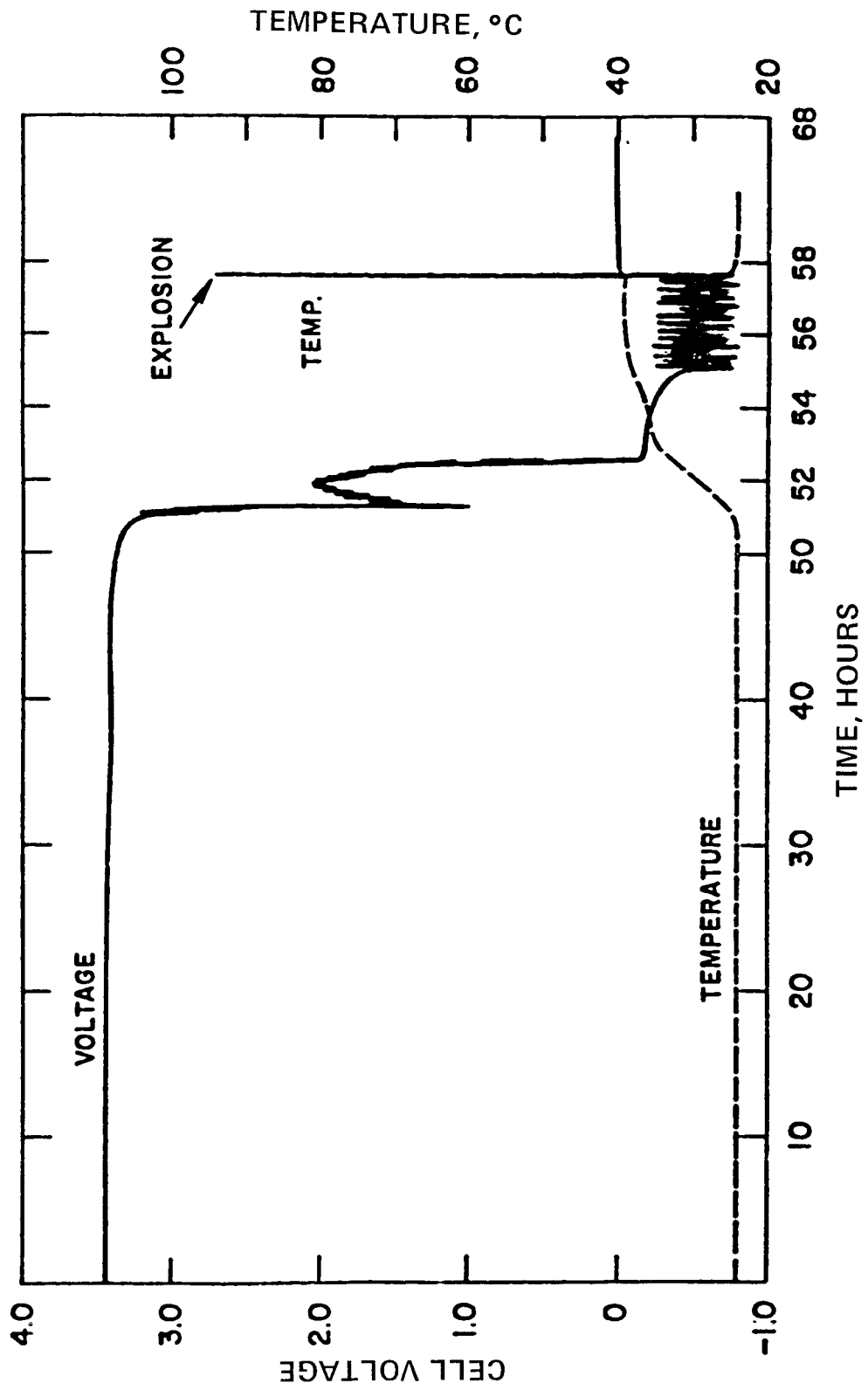
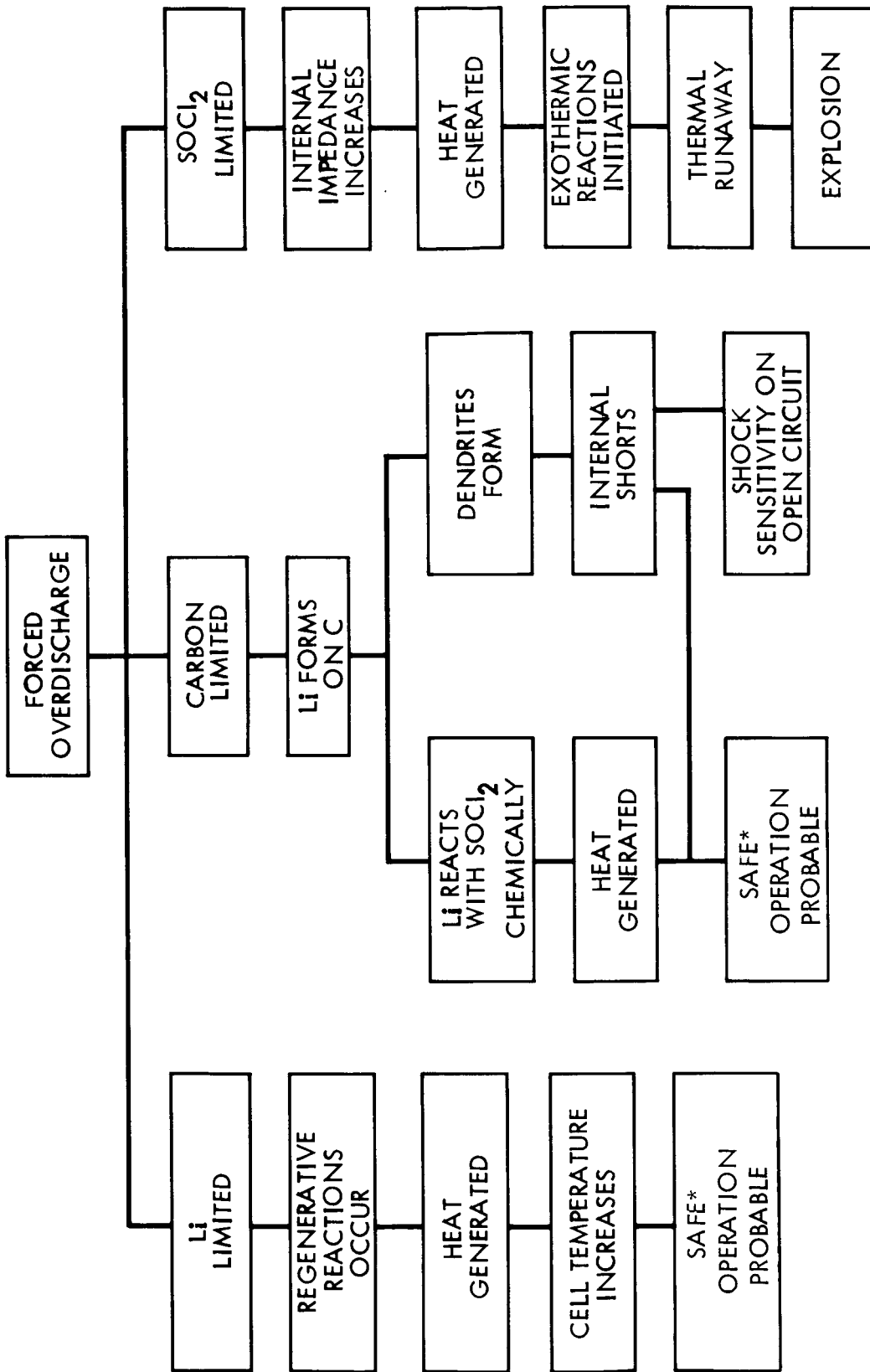

Figure 5-8. Discharge and Reversal of a Li-SOCl₂ Cell⁷



*VENTING/EXPLOSION POSSIBLE DEPENDING ON DESIGN ENVIRONMENT, HEAT DISSIPATION, AND THE PRESENCE OF ADEQUATE ELECTROLYTE.

Figure 5-9. Influence of Reversal on Li-SOCl₂ Cell at Ambient Temperature

Table 5-1. Overview of Reversal Processes

DESCRIPTION	LITHIUM LIMITED	CARBON LIMITED	SOCl ₂ LIMITED
CELL DESIGN	SUITABLE FOR LOW RATE CELLS	SUITABLE FOR BOTH HIGH AND LOW RATE CELLS	NOT RECOMMENDED
END OF DISCHARGE	CAUSED BY THE DEPLETION OF Li	CAUSED BY THE PASSIVATION OF CARBON ELECTRODE	HIGH INTERNAL IMPEDANCE CAUSED BY THE DEPLETION OF SOCl ₂
REACTIONS DURING REVERSAL	<p><u>ELECTROCHEMICAL ANODE</u> $2 \text{SOCl}_2 + 2 \text{AlCl}_4^- \longrightarrow \text{SO}_2\text{Cl}_2 + \text{SOCl}_2 + \text{Cl}_2 + 2 \text{AlCl}_3 + 2 \text{e}^-$</p> <p><u>CATHODE</u> $\text{Li}^+ + 1/2 \text{Cl}_2 + \text{e}^- \longrightarrow \text{LiCl}$</p> <p><u>CHEMICAL</u> $\text{LiCl} + \text{SOCl}_2 + \text{AlCl}_4^- \longrightarrow \text{SOCl}_2 + \text{LiAlCl}_4$ $\text{LiCl} + \text{AlCl}_3 \longrightarrow \text{LiAlCl}_4$ (EXOTHERMIC)</p>	<p><u>ELECTROCHEMICAL ANODE</u> $\text{Li} \longrightarrow \text{Li}^+ + \text{e}^-$</p> <p><u>CATHODE</u> $\text{Li}^+ + \text{e}^- \longrightarrow \text{Li}$</p> <p><u>CHEMICAL</u> AT CATHODE (IF CARBON IS ACTIVE) $4 \text{Li} + 2 \text{SOCl}_2 \longrightarrow 4 \text{LiCl} + \text{SO}_2 + \text{S}$ EXOTHERMIC</p>	<p><u>ELECTROCHEMICAL</u> LiAlCl₄ ELECTROLYSIS IS POSSIBLE</p> <p><u>CHEMICAL</u> $\text{Li} + \text{S} \longrightarrow \text{HEAT}$ $\text{Li} + \text{GLASS} \longrightarrow \text{HEAT}$</p>
PROBABLE IMPLICATION ON CELL SAFETY	<p>Cl₂ AND AlCl₃ FORMED AT ANODE ARE CONSUMED AT THE CATHODE REGENERATING AlCl₄⁻</p> <p>THE HEAT GENERATED RAISES INTERNAL CELL TEMPERATURE</p>	<p>A) LITHIUM DENDRITES CAN PRODUCE INTERNAL SHORTS</p> <p>B) CHEMICAL REACTION OF S/SOCl₂ PRODUCES HEAT RAISING THE INTERNAL CELL TEMPERATURE</p>	<p>EXCESSIVE HEAT GENERATED WITH INCREASE IN IMPEDANCE (I²R) - RESULTING IN HIGH INTERNAL CELL TEMPERATURE, CHEMICAL REACTIONS ABOVE AND POSSIBLE THERMAL RUNAWAY</p>
R & D ISSUES	A) HEAT GENERATION AS F (RATE, TEMPERATURE)	<p>A) STRUCTURE AND REACTIVITY OF Li DENDRITES</p> <p>B) REPORTED FORMATION OF Li₂O AND ITS ROLE IN SAFETY</p>	CHEMISTRY OF STARVED CELLS

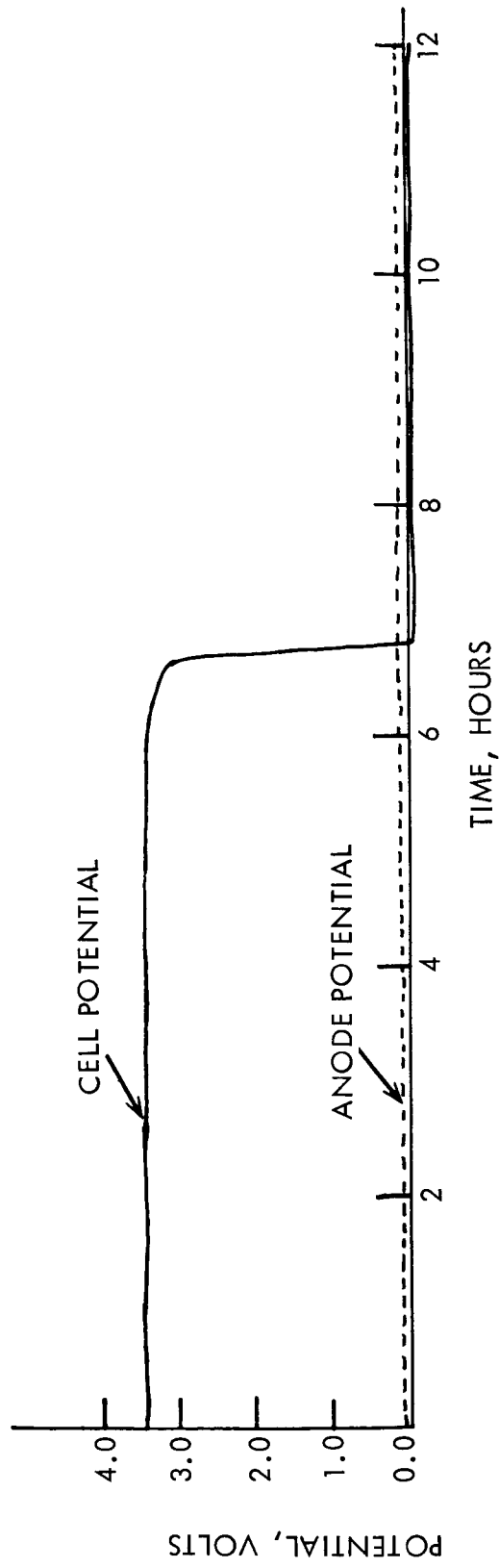

Figure 5-10. Discharge and Reversal of a carbon-limited Li-SOCl₂ Cell (2 mA/cm²)

and Dampier⁵⁸ reported the presence of Li_2O_2 in the carbon electrodes after 10-percent reversal, based on their X-ray data. However, they did not observe Li_2O_2 in carbon electrodes that were completely discharged without being reversed. They also reported the growth of dendrites (scanning electron microscope studies) during CLVR, but had no firm evidence that the dendrites formed were Li.

In spite of the great understanding gained on the chemistry of Li-SOCl_2 cells during CLVR, the implications of the chemical reactions on cell safety are not completely understood, and many differences of opinion exist among various researchers. K.M. Abraham^{51,54} and M. Domeniconi⁵⁹ reported that carbon-limited cells are safer and may be reversed for indefinite periods of time. They believe this because lithium deposits on the carbon form dendrites, which in turn physically short the cell internally and enable the reversal current to flow. However, many others believe that these cells are not safe because:

- (1) Li deposited on the carbon electrode may react with S (formed in the carbon electrode pores during normal discharge) at cell temperatures above 120°C , liberating a great deal of heat.²⁵
- (2) Li in contact with the carbon electrode may react exothermally with the electrolyte leading to thermal runaway of the cell.^{27,60}
- (3) If Li_2O_2 is present in carbon cathodes, it may pose a safety hazard because of its oxidizing characteristics. Carbon reacts with sulfur exothermally in the presence of oxidizing agents such as Li_2O_2 (gunpowder scenario).
- (4) Cells may be shock sensitive because Li dendrites on the carbon electrode may disintegrate into fine particles upon shock and react with SOCl_2 , liberating heat.^{27,60}

Summarizing the concerns for safety in carbon-limited cells during reversal, all interpretations of safety center around lithium dendrite formation. However, to date no firm evidence exists regarding the presence of lithium dendrites on the carbon electrode. Although the reactivity of these dendrites present on a fully passivated carbon electrode in the presence of SOCl_2 and other reducible species is not known, it is thought to be appreciable. It was reported earlier that the reaction between Li and S does not take place at lower temperatures in the presence of excess SOCl_2 .²⁶ Similarly, there is also the question regarding the nature of the dendrite-formed short circuits and how much reversal current can be carried by the dendrites during the reversal process. A better understanding of these issues is needed to make an assessment of this cell design on the issue of safety.

2) Anode-Limited Cells. A cell may become anode-limited at the end of discharge in three ways: 1) depletion of the lithium, 2) inaccessibility of lithium under operating conditions, and 3) separation of lithium from the grid. A cell undergoing reversal due to the first cause will be referred to as lithium-limited voltage reversal (LLVR), while the second and third causes will be termed anode-limited voltage reversal (ALVR).

Figure 5-11 shows the voltage behavior of a typical lithium-limited cell during discharge and reversal. The anode becomes polarized towards more positive potentials, causing a lowering of cell voltage. Cell voltage is zero when the anode potential is equal to that of the cathode potential (SOCl_2 reduction). Upon continuing the discharge beyond this point, the anode is forced to voltages more positive than the cathode and negative cell voltages. The voltage is more negative than -1.0V . This value is different from that observed in carbon-limited cells (-0.1V).

K.M. Abraham^{51,54,55} reported that the type of cell in which practically all Li has been used up did not exhibit hazardous behavior. In some cells he observed large potential oscillations that might have been due to intermittent contact between the unutilized lithium fragments and the nickel screen. These cells were reported to deteriorate.

The reactions taking place at low rates of discharge during LLVR were examined in detail by K.M. Abraham et al.,^{51,54,55} D.J. Salmon,⁶¹ A.I. Attia et al.,³² and B.J. Carter et al.⁶² They reported that the reactions were quite complex and regenerative in nature. The Cl_2 , AlCl_3 , SO_2Cl_2 , SCl_2 , and S_2Cl_2 were formed at the anode due to the oxidation of SOCl_2 . Cl_2 and SO_2Cl_2 were reduced at the cathode, producing LiCl and SO_2 . Details of the electrochemical and chemical reactions taking place during LLVR are shown in Table 5-2.

The various products identified by B.J. Carter et al.⁶² in the electrolyte of the cells that were subjected to LLVR are Cl_2 , SO_2 , SO_2Cl_2 , SCl_2 , and S_2Cl_2 . A wide range of analytical instrumentation was used to confirm the presence of these products. In addition, D.J. Salmon et al.⁶¹ reported the existence of S_2O and Cl_2O in the electrolyte. They proposed that the presence of Cl_2O may explain the safety problems of this type of cell.

However, infrared spectral evidence alone is not sufficient to confirm the presence of Cl_2O , and further, formation of Cl_2O appears contrary to its known chemistry. A.I. Attia³² reported the presence of SOCl_2 , SO_2 , and S_2O in the gas phase of these cells by high-resolution mass spectrometry. They did not observe Cl_2O in the electrolyte.

From the reactions shown in Table 5-2, a highly acidic environment prevails during LLVR.

A difference of opinion exists among researchers regarding the safety of lithium-limited cells. Their findings are summarized below:

- (1) K.M. Abraham⁶³ reported that Li-limited cells in which practically all the lithium had been used up before reversal did not exhibit hazardous behavior. However, in the case of anode-limited cells not lithium limited, cell detonations were observed (see Figure 5-12). In such cells they noted anode potentials more negative than 4V with larger oscillations preceding detonations. The voltage fluctuations were believed to be caused by intermittent contact between the anode substrate and the residual lithium.

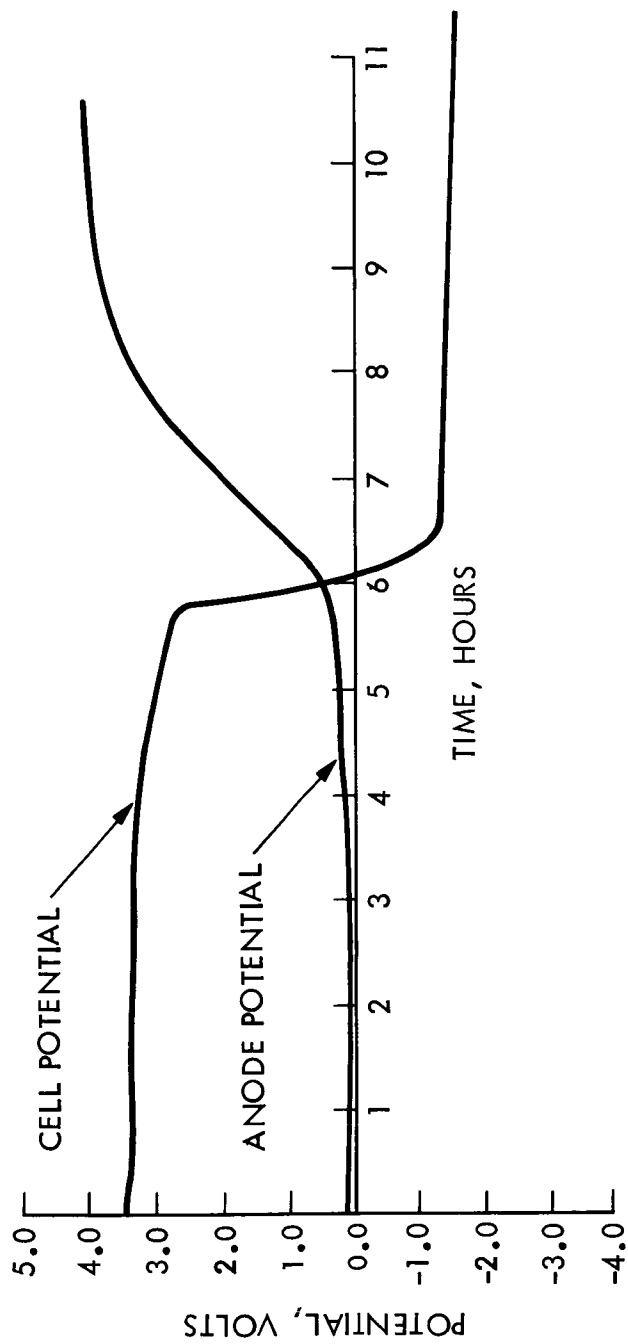

Figure 5-11. Discharge and Reversal of a Lithium-Limited Li-SOCl₂ Cell
(2 mA/cm²)

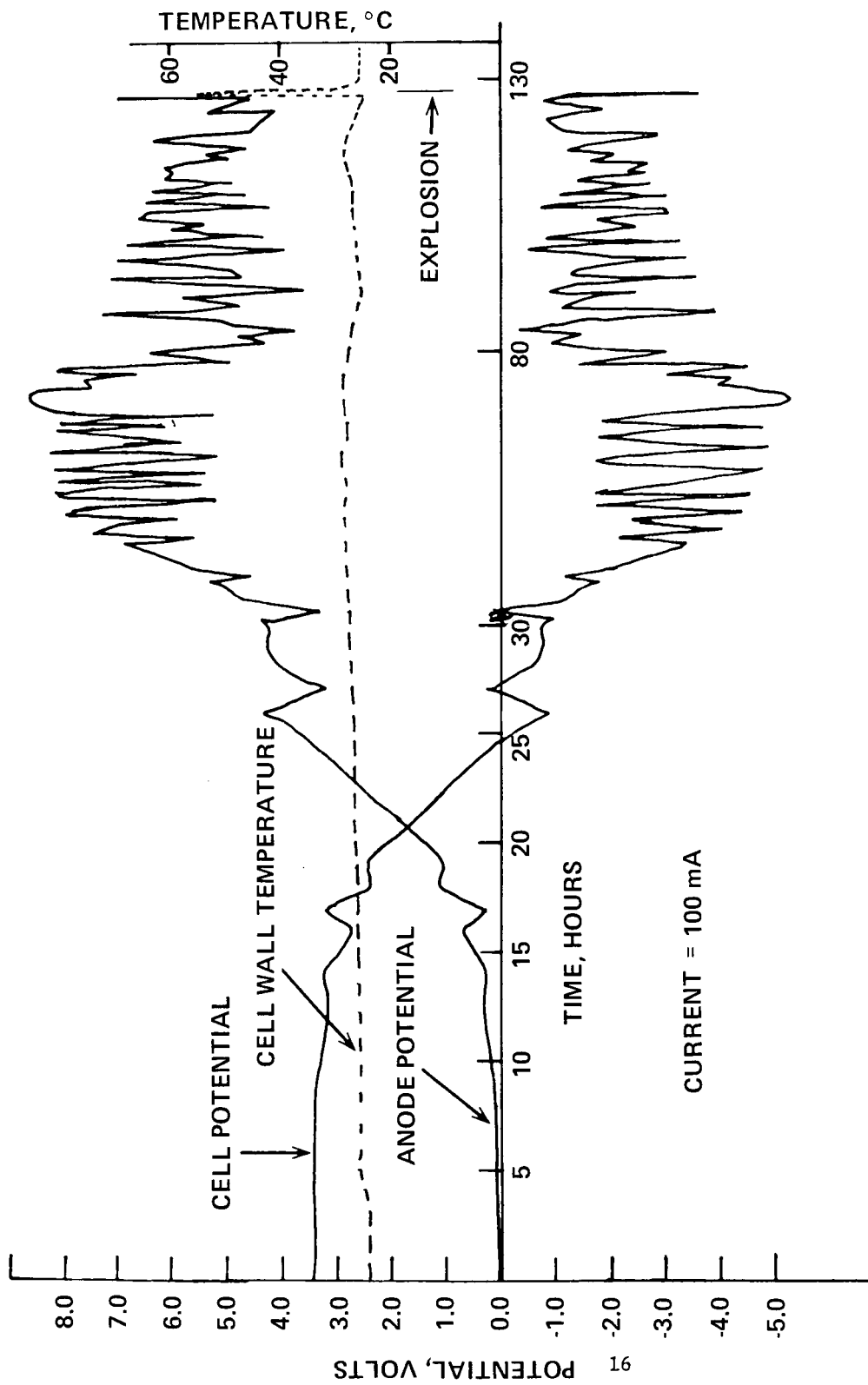
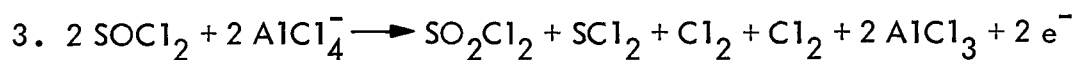
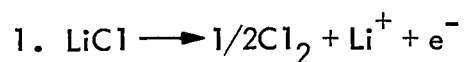

Figure 5-12. Discharge and Reversal of an Anode-Limited (Not Lithium-Limited) Li-SOCl₂ Cell⁵⁴

Table 5-2. Reactions During Lithium-Limited Reversal^{54,62}

ANODE:



MECHANISM:

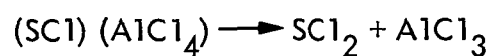
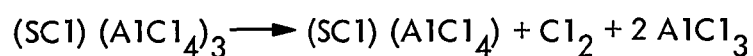
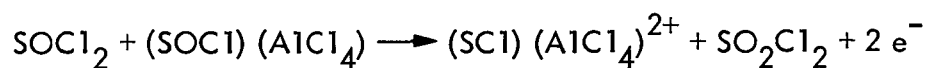

(2) D.J. Salmon⁶¹ et al. pointed out that Cl_2O formed during reversal may explain the problems during LLVR.

(3) D.I. Chua⁶⁴ et al. reported that anode-limited cells exhibited capacities within a narrow range when fresh, with the probability of a cell in a battery undergoing reversal being statistically low.

(4) N. Doddapaneni⁶⁵ observed a high rate of heat generation in these cells during LLVR.

(5) D.H. Johnson⁶⁶ reported that the lithium-limited design was safe for low-rate cells.

(6) Since lithium is not present during LLVR, no possibility exists for exothermic reactions between Li and SOCl_2 or S, which are believed to cause thermal runaway in Li- SOCl_2 cells. Further, such cells do not cause fires during the disposal² of used cells.¹⁰

3) Solvent/Thionyl Chloride-Limited Cells. SOCl_2 is electrochemically reduced at the carbon electrode and hence its quantity decreases during discharge. Depending on utilization, temperature, cell balance, etc., its volume at the end of discharge may vary. In the type of cell described here, useful life is determined by the amount of liquid depolarizer (catholyte), i.e., SOCl_2 , present. This design is favored by some to gain high energy densities because the mass of SOCl_2 is minimized, and, therefore, the energy-to-cell-weight ratio is increased.² This design, however, appears to be hazardous (compared to the lithium-limited or carbon-limited designs), especially for cells that are intended for operation at low to moderate rates of discharge and where there is the possibility of cells being driven into reversal. Some explosions reported to date during reversal may be attributed to cells that were SOCl_2 -limited in design or became SOCl_2 -limited during reversal at the rates utilized. However, detailed studies have been published to date on the chemistry and behavior of such electrolyte-starved cells during forced discharge.

Several chemical reactions may take place during reversal in such cells. The reversal current passing through the cell may lead to electrolysis of the LiAlCl_4 salt, generating Cl_2 , AlCl_3 , and Li. Further, certain dry spots may appear on the electrodes as SOCl_2 is consumed. These dry spots may result in an increase in internal resistance. The polarization heat thus generated may initiate exothermic reactions between Li and S, or Li and the glass separator paper. These reactions are strongly exothermic and may account for the unsafe behavior of SOCl_2 -limited cells.

SOCl_2 has various roles in the Li- SOCl_2 cell. It serves as a cathodic reactant, electrolyte solvent, and heat sink. Battery engineers are aware of all the roles of SOCl_2 ; however, they tend to place emphasis on energy density when designing cells. Thus, they provide quantities of electrolyte sufficient only for normal discharge and some excess (10 to 20 percent) to account for various faradaic inefficiencies. A safe approach is to provide SOCl_2 in adequate quantity to account for normal discharge, to sustain good ionic conductivity during discharge and reversal, and to keep SO_2 and

other discharge products in the liquid phase. Such a design may impose a weight penalty on the cell, but it reduces the incidence of safety problems.⁴⁰

The use of cosolvents such as BrCl, sulfolane, etc., have been reported to enhance cell safety by improving the solubility of sulfur or sustaining conductivity during reversal.^{67,68} However, such cells may have safety problems similar to those documented for Li-SO₂ cells. Use of excess SOCl₂ can sustain conductivity, improve mass transfer properties, keep discharge products in solution, and preserve the LiCl film on Li. Obviously, this approach is preferred.

Suggested Improvements. A number of solutions have been proposed for improving the safety of cells during reversal. A summary of the safety implications of each type of design is given below. One design that has not been discussed is the balanced cell design, in which both the Li and SOCl₂ are fully consumed at the end of discharge and the carbon electrode is just passivated. Such a design may theoretically be possible but difficult to achieve in practice because of the differences in the utilization of the electrodes under various operating conditions. Such well-balanced cells are thought to be safe only if operated at extremely low rates of discharge (<C/100) and the cells find applications as individual cells only. Cells required for watches, pacemakers, and other electronic devices are examples in this category. The studies reported in literature suggest:

(1) Lithium-Limited Design. For low-rate applications (<C/10), lithium-limited designs are reported to be safe.

(2) Carbon-Limited Design. For moderate to high-rate (>C/5), applications, the discharge will result in carbon-limited cells. For improving the safety of carbon-limited cells, the following approaches have been recommended:

o Liang et al.⁶⁷ reported on the additions of BrCl to the electrolyte. They reported an increase in the solubility of sulfur in the BrCl containing electrolytes. Others believe that it may be due to the modification of surface characteristics of carbon.

o Use of sulfolane⁶⁸ as a cosolvent to SOCl₂ was recommended. However, detailed investigations are necessary to examine any changes in cell chemistry and its effect on cell safety.

o M. Domeniconi⁵⁹ proposed certain changes in the seal design. These modifications permit the deposition of Li on the outer section of the seal; the Li continues to grow and eventually makes an internal short. This feature is regarded as an electrochemical switch that closes on voltage reversal. In this fashion, the current being applied to the cell during reversal may pass harmlessly through a solid conductor pathway, and thus hazardous reactions are avoided.

o The authors of this report, however, are of the opinion that the use of excess SOCl_2 will improve the safety of both lithium- and carbon-limited cells.⁴⁰

(3) Thionyl Chloride-Limited Design. SOCl_2 -limited cells are considered unsafe.

There is no universal solution proposed so far for cells required for different applications. One may have to select a suitable approach depending on performance requirements and then evaluate its soundness.

5.2.1.3 Charging. The charging of primary cells in general is not advisable. However, this condition may occur in the case of cells/packs connected in parallel. When one cell in one pack fails, the potential of the second pack will cause current to flow in the charge direction through the first pack because of its lower resistance. Some primary cells can be recharged relatively safely, especially if only a small percentage of their capacity has been removed. The effect of charging on the chemistry of Li- SOCl_2 cells has been investigated in detail.^{51,54,61,62} The results obtained so far indicate that under certain conditions, charging at low currents may not result in a safety problem for hermetically sealed Li- SOCl_2 cells. The voltage of the cells was found to increase depending upon how much capacity had been removed. The non-discharged cells exhibited relatively uniform voltages of $4.0\text{V} \pm 0.1\text{V}$, depending upon the charging current (Figure 5-13). On the other hand, the charge voltages for discharged cells were more scattered. Even after charging, the cells (non-discharged) exhibited normal discharge performance. It was noted that the discharged cells did not acquire any appreciable capacity as a result of charging process. Charging Li- SOCl_2 cells at high rates might pose safety problems; however, detailed studies are needed for confirmation.

The products formed during cell charging were found to be identical to those formed during LLVR. In view of the problems associated with LLVR, Abraham et al.⁵⁴ suggested that caution be exercised in charging the cells irrespective of the observation that this mode of operation appeared safe. A possibility exists for complete or partial disintegration of the carbon electrode during the charging process as is observed commonly in the chloroalkali industry. This could lead to unreliable cell performance, and, therefore once charged, a cell should be removed as a power source candidate. [The basic control is avoid paralleling batteries or strings of cells within a battery or paralleling batteries with other external power supplies, any of which may force a charging current through a stack of cells containing a weak or dead cell(s). However, if parallel strings of cells must be used, each string must contain its own blocking diode. Batteries that must be paralleled with external power sources must be equipped with charge current block devices.] Figure 5-14 shows the effects of charging on the safety of Li- SOCl_2 cells.

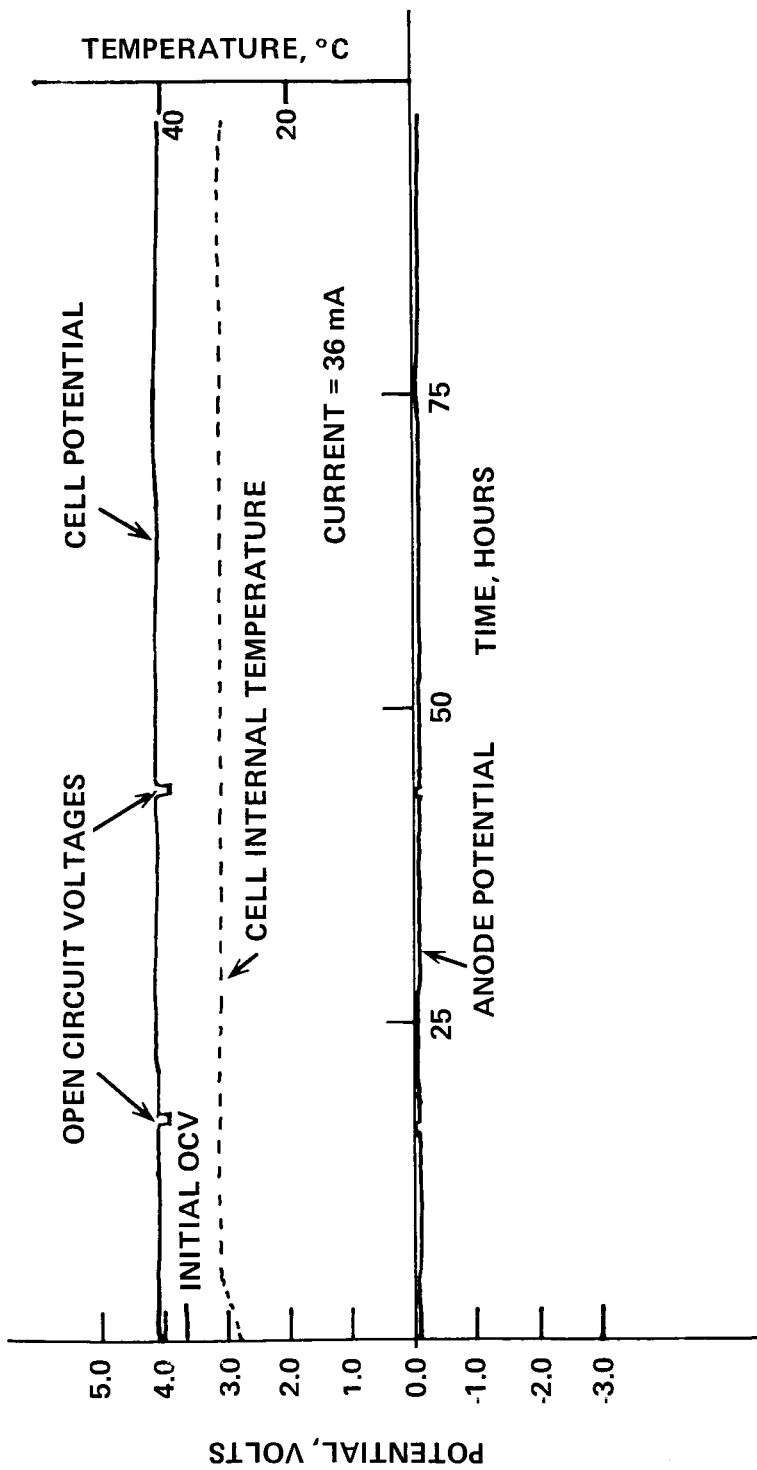
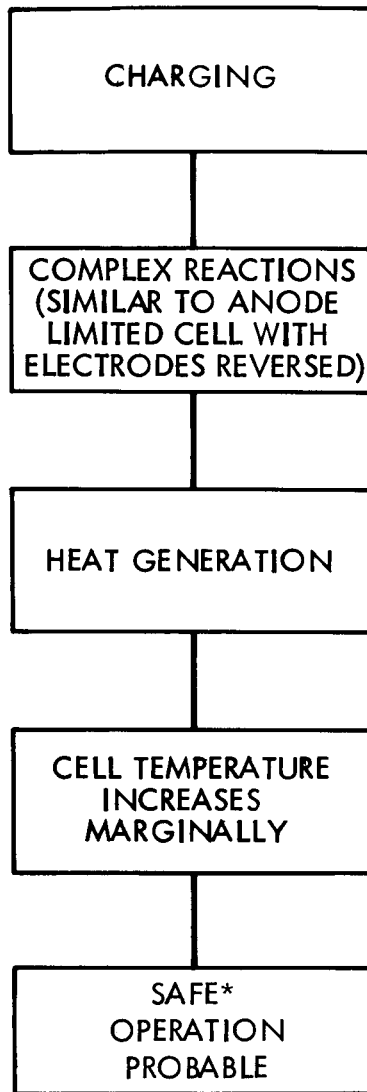

Figure 5-13. Characteristics of Li-SOCl₂ During Charge⁵⁴



*VENTING/EXPLOSION POSSIBLE DEPENDING ON DESIGN ENVIRONMENT,
HEAT DISSIPATION AND CHARGE RATE.

Figure 5-14. Influence of Charging on Li-SOCl₂ Cell Safety

5.2.2 Physical/Mechanical Abuse

Cells/batteries are at times inadvertently subjected to physical abuse such as piercing and crushing during storage and transportation. The influence of such acts on the safety of Li-SOCl₂ cells is examined below.

Puncturing a cell/battery with any device provides a means for the escape of electrode materials and discharge products from the cell and may also result in internal electrode shorting. The chemicals formed in the cells are generally toxic in nature, and, hence, puncturing a cell/battery may create pose a safety hazard. Crushing a cell generally results in case deformation and cell rupture followed by expulsion of the electrode materials and discharge products from the cell. It may also result in internal electrode shorting. The effects of puncturing and crushing Li-SOCl₂ cells was examined in detail by J.F. McCartney et al.,⁶ D.H. Johnson,⁶⁶ M. Babai,⁴⁷ and K.F. Gatuotte et al.⁴⁶ The hazards varied from mild venting to explosion, depending upon cell design. Cells of bobbin-type construction vented, releasing toxic gases/materials including SO₂, Cl₂, and SOCl₂; whereas fresh cells of both spiral-wind and prismatic configurations with parallel plate electrodes exploded violently. Puncturing a fully discharged cell could result in the venting of toxic gases/materials. Partially/fully discharged cells were reportedly sensitive to shock compared to fresh cells. Consideration must be given to the location of a cell in the battery and in equipment so as to avoid puncture or crushing.

5.2.3 Thermal/Chemical Abuse

Possible thermal/chemical abuses that a cell/battery may undergo include exposure to high temperature from fire/flame and corrosion due to exposure to high humidity and/or corrosive solutions, e.g., salt water. The severity of the safety problems varies significantly depending upon the type of cell/battery. All types of Li-SOCl₂ cells vent or explode violently if they are subjected to temperatures higher than about 200°C by any means such as exposure to open fire or local heating with a flame, e.g., propane torch.^{6,66} Exposure of Li-SOCl₂ cells to moisture or salt solution may not pose a problem immediately, but in the course of time the cells may corrode and vent toxic materials even though most cell cases are made of stainless steel. Seals of various types have been known to degrade in high humidity.⁶

5.3 NON-OPERATIONAL CONDITIONS

5.3.1 Handling

The recommended handling of Li-SOCl₂ cells and batteries is not much different from that of other lithium batteries. Various regulations and rules have been issued by the U.S. government for transporting and disposing Li-SO₂ cells. These rules and regulations also apply to Li/SOCl₂ cells. A detailed discussion of the subject is beyond the scope of this review, but a brief review of the implications involved in maintaining cell safety during storage, transportation, and disposal follows below. Articles by L.J. Johnson et al.,⁹

M. J. Brookman,⁶⁹ G. Halpert,⁷⁰ and government regulations (Appendix A) provide more information.

5.3.1.1 Storage. Recommended temperatures for storing Li-SOCl₂ cells range from 0°C to 40°C. As with other electrochemical systems, cell performance deteriorates if they are stored at temperatures higher than 45°C (Figure 5-15). Cells may also exhibit severe voltage delay after storage at high temperatures. Spirally wound cells may vent or explode if stored at temperatures higher than 100°C. This may be due to reactions between S and SOCl₂ (130°C)⁶⁴ or Li and SOCl₂ (180°C).⁶⁰ The lower the storage temperature, the less severe is post-storage degradation of cell performance.

Cells that are driven into reversal are reported to be sensitive to shock when stored on open circuit.²⁰ Such cells may vent or explode if they are subjected to shock or crushing. Hence, great care is needed while handling such cells and batteries. The following precautions have been recommended for storing used and new batteries:⁹

(1) Fresh cells/batteries:

- o Store the cells/batteries isolated from combustible materials and other hazardous materials.
- o Store the cells at temperatures below 130°F (40°C).
- o Store the cells only in a well-ventilated area.
- o Since the effect of mass storage on the hazard degree is not known, the quantity of cells stored in an area should be kept to a reasonable minimum.
- o The storage area must be kept equipped with automatic smoke and fire detection equipment. Proper fire fighting equipment must also be available in the storage area.
- o Special care must be exercised in handling and moving the cells/batteries to prevent them from being crushed or puncturing.

(2) Used batteries:

- o Never store used and fresh batteries together.
- o Never allow excessive quantities of cells to accumulate. Disposal should be effected periodically.
- o Used lithium batteries should not be subjected to physical abuse. Proper disposal methods should be used for disposal (described in subsection 5.3.2).

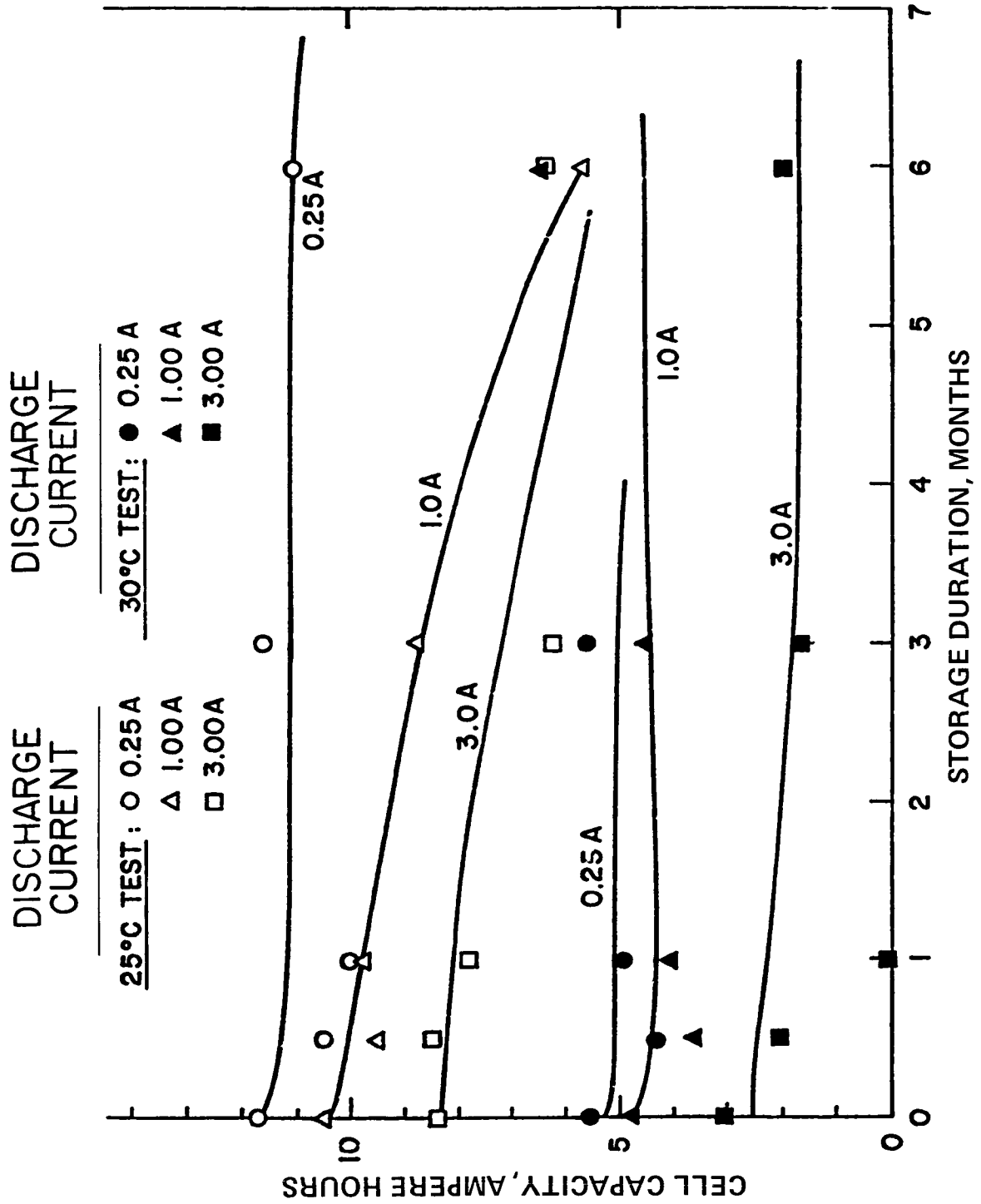

Figure 5-15. Effect of Storage Temperature on Li-SOCl₂ Cell Performance⁷

5.3.1.2 Transportation. Transportation of both new and used batteries is governed by federal regulations relating to the shipment of hazardous materials. The general regulations are published in 49CFR172.101, 173.206(E)(L) and 175.3. The Research and Special Programs Administration of the U.S. Department of Transportation has issued exemptions to allow the shipment of lithium cells and batteries, if detailed requirements regarding cell size, testing results, and packaging are met. Fresh batteries, alone or in equipment, may be shipped by motor vehicle, rail freight, cargo vessel, and cargo-only aircraft under Exemption DOT-E-7052 (Appendix A). Any company or group shipping under this exemption must be explicitly registered with the Department of Transportation prior to shipping batteries by any mode. Exemption DOT-E-8441 permits the shipment of waste lithium batteries to a disposal site by motor vehicle only.

5.3.2 Disposal

Improper disposal of Li-SOCl₂ cells may be very hazardous. The hazards are due basically to extreme reactivity and the toxic nature of cell components and discharge products. Lithium reacts violently with water and sometimes results in explosion. Li and LiOH may cause caustic burns to the skin. Special fire extinguishing materials are required to put out lithium fires. SOCl₂, SO₂, and SO₂Cl₂ are highly toxic and if inhaled may cause serious inflammation of lung tissue. LiAlCl₄ may quickly dehydrate the tissue. Hence the cells have to be treated as hazardous waste, and extreme care is needed in disposing of these cells/batteries. They cannot be thrown away like Zn-MnO₂ and alkaline cells. They have to be disposed of per the established and recommended safe procedures. These procedures require the disposal of cells as hazardous waste after deactivation.

Some procedures that have been attempted in the past to deactivate smaller cells include puncture, hydrolysis, and chemical neutralization.^{71,72} N. Marincic et al.⁷² and R.C. McDonald et al.⁷³ described procedures for disposing of large cells. For detailed descriptions of the disposal of cells in large quantities, Environmental Protection Agency assistance has to be sought.

SECTION 6

MANUFACTURER-INDUCED FACTORS

Many safety problems encountered with Li-SOCl₂ cells may also be due to deficiencies in cell design and in effective quality control during cell fabrication. Bobbin-type cells appear to be relatively safe under most operating conditions because this type of cell has been designed for low-rate applications. Most safety problems are reported for AA, C, and D cells of jellyroll design. In addition to user-induced safety problems described in Section 5, the unsafe behavior of these cells may be due to inherent design or quality problems that are considered manufacturer induced. Manufacturer-induced safety issues shown in Figure 4-1 are discussed in this section.

6.1 CELL DESIGN

Cell design has a significant influence on the performance and safety of any electrochemical system. The cell design discussion here is based on manufacturer involvement in optimizing the cell for overall performance and safety. Battery engineers in general try to improve performance by making design improvements in the configuration and structure of the electrodes, electrolyte, separator, case, and cover and their interactions. This discussion emphasizes the influence of cell and component design on safety.

The parameters that constitute cell design may be classified into four groups: 1) electrochemical, 2) electrical, 3) structural/mechanical, and 4) thermal. The influence of these four areas on cell safety is discussed below.

6.1.1 Electrochemical

The important parameters under this design category are the nature of the limiting electrode (anode- or cathode-limited), ratio of electrode capacities, electrode structure, electrolyte composition, etc. The optimization of these parameters requires the consideration of the electrochemical and chemical reactions taking place during discharge, forced over-discharge, charge, and storage. The significance of the limiting electrode was discussed in detail in subsection 5.2.1.2. The overall provisional conclusions show that:

- 1) A balanced design is suitable for cells required for very low-rate applications (C/100) and that do not undergo reversal (used as single cells).
- 2) Lithium-limited cells are relatively safe. However, that condition exists only at low rates of discharge (C/10) and at room temperature and higher temperatures.

3) For medium- to high-rate cells and cells that are required to operate at lower temperatures, the carbon-limited design appears to be the only choice.

4) Electrolyte/SOCl₂ limited cells are highly unsafe. Some of the explosions reported in the literature may be attributed to this condition.

The variation of electrolyte conductivity with salt concentration in SOCl₂ is shown in Figure 6-1.⁷⁴ The figure shows that electrolyte conductivity at 25°C increases up to a salt concentration of 1.8M and thereafter it decreases. In view of this, designers have preferred a concentration of 1.8M LiAlCl₄ so far. However, during discharge, SOCl₂ is consumed, and at the end of discharge, the salt concentration in SOCl₂ may approach 4.0M - 8.0M depending upon the situation. In view of this, it may be preferable to use a lower salt concentration (1.0M - 1.5M).

To achieve high energy densities, battery engineers tend to provide minimum quantities of the electrolyte. However, this may have a serious impact on cell safety. In Li-SOCl₂ cells, SOCl₂ serves both as a positive electrode material and solvent for the electrolyte salt and discharge products. So SOCl₂ must be present in an adequate quantity to sustain normal discharge and provide conductivity.⁴⁰ Most explosions experienced with these cells may be attributed to electrolyte starvation during the end of discharge or reversal. For a detailed discussion on this topic, refer to subsection 5.2.1.2.

6.1.2 Mechanical

6.1.2.1 Structural. The main function of the cell case is to house various cell components (anode, cathode, electrolyte, etc.) and to prevent them from coming into contact with the atmosphere. Further, the cell case must be able to contain gases produced during discharge, forced over-discharge, and storage. In view of this, the cylindrical configuration is preferred for the cells since it can withstand higher pressures than the prismatic configuration. However, an examination of present cylindrical designs indicates that there is not enough overhead volume (above the electrodes) to contain the gases. So changes may be required in the hardware design of cylindrical cells. If gas generation can be minimized, a structurally enhanced prismatic configuration may be feasible. Joining the case to the cover through crimp seals is not advisable for Li-SOCl₂ because the seam may leak over a period of time. The welding of case and cover by TIG welding or laser is strongly recommended.

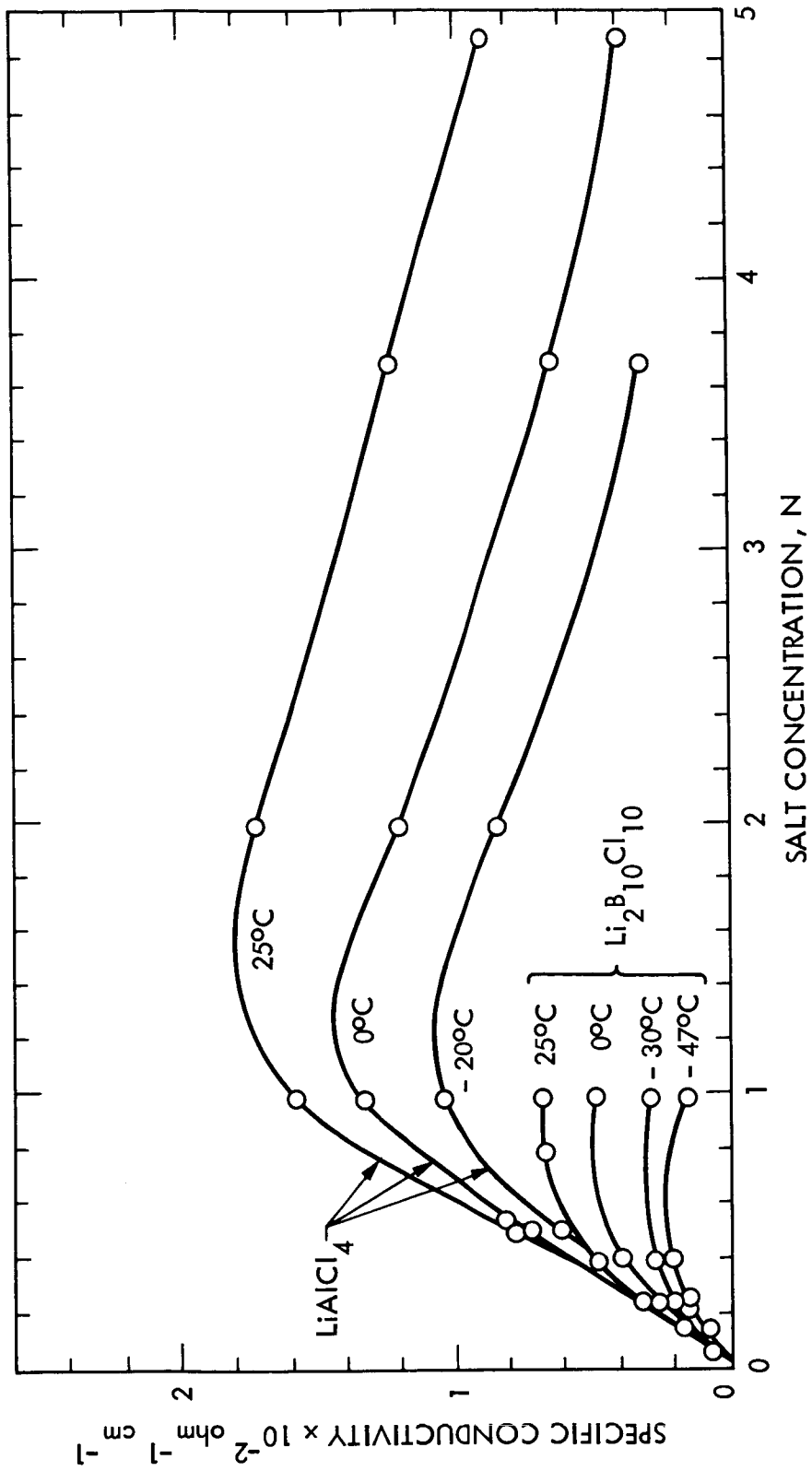

Figure 6-1. Specific Conductivities of LiAlCl₄-SOCl₂ and Li₂B₁₀Cl₁₀-SOCl₂ Electrolytes as a Function of Salt Concentration

6.1.2.2 Thermal. In Li-SOCl₂ cells, safety problems are due mainly to inadequate heat management. An ideal cell design must minimize heat generation and maximize heat dissipation. For low to moderate rates this is not a significant problem unless the cell is in a battery case where the heat conduction path is inadequate. However, for higher rates (>C/10), internal heating is a significant problem. A greater emphasis on thermal design is needed to meet extended applications.

A complete thermal analysis must consider all heat sources and heat sinks, their evolution with time, and their location. In addition, battery engineers also have to consider heat effects due to all non-electrochemical reactions that may take place during discharge and reversal as well as during post-discharge periods. The situation is further complicated by the fact that thermal and the electrical conductivities as well as electrode polarization are temperature and electrolyte composition dependent.

6.1.3 Electrical

Non-uniform current distribution may lead to high polarization at high rates of discharge, which may also account for unsafe cell behavior. In order to achieve uniform current distribution, square electrodes may be the choice. The use of jellyroll (long and narrow) electrodes may result in non-uniform current distribution. The use of multiple tabs may minimize the problem to a certain extent.

Presently, all cells are equipped with one insulated terminal only. Failure of the seal (terminal, glass tabs) for any reason (corrosion, bridging, breaking, or cracking) may result in cell shorting, an open circuit, or a release of toxic gases and electrolyte. Improvement in the structural and chemical stability of the glass-to-metal seal is needed to enhance cell safety.

6.2 QUALITY CONTROL

It is essential to emphasize the importance of quality control during cell manufacture. Highly reliable nickel-cadmium cells were made possible only through effective implementation of a stringent quality control program during their manufacture. For convenience, the quality control program may be divided into four categories: 1) quality control of raw materials, 2) inspection of components including electrode and electrolyte processing, 3) inspection of cell assembly, and 4) acceptance/qualification of finished cells.

The use of high-purity materials and the minimization of contamination during processing is essential to realize high quality cells. Impurities that may be present in various raw materials and other cell components are presented in Table 6-1. Among these impurities, Li₃N, HCl, Fe, H₂O, and organic polymers/materials have a significant influence on the performance and safety of Li-SOCl₂ cells.⁷⁵⁻⁷⁶

Table 6-1. Possible Impurities in Various Materials of Li-SOCl₂ Cells

MATERIAL	IMPURITY
Li	LiN ₃
C	H ₂ O, ORGANIC MATTER, TRACES OF METALLIC IMPURITIES
LiCl, AlCl ₃	Fe, H ₂ O
SOCl ₂	Cl ₂ , SO ₂ , HCl, S ₂ Cl ₂
SEPARATOR	ORGANIC POLYMERS Fe, H ₂ O
NICKEL EXMET	Fe, Cu

Lithium nitride reacts violently with the electrolyte only at temperatures above 125°C. If by any chance the electrolyte contains traces of HCl formed by the hydrolysis of SOCl_2 , a reaction between Li_3N and SOCl_2 may take place with incandescence even at room temperature. The relationship between nitride particle size and the maximum safe concentration of hydrolysis products has not yet been established. Lithium nitride may form as small spots or nodules on the surface of the lithium foil if it is stored for a long period even in atmospheres containing very low concentrations of nitrogen and traces of water vapor. These spots may act as sites in increasing further corrosion of the metal by nitrogen. Li_3N may form on the Li electrodes when the fabricated cells are stored in an unfilled condition for a long time. The presence of HCl is possible in the electrolyte if the cathode or separator are not dried properly or if leaks have exposed the electrolyte to the atmosphere. Every measure must be taken to minimize the presence of Li_3N and HCl in the Li electrode and electrolyte, respectively.

Cells have exhibited serious voltage delay characteristics if Fe greater than 5 p/m is present in the electrolyte. However, it is preferable to restrict the Fe concentration to values below 3 p/m.

Most seriously, organic impurities may result in gas evolution due to their reactions with the $\text{LiAlCl}_4/\text{SOCl}_2$ electrolyte. The main organic contaminations come from the separator paper. The Naval Weapons Support Center (NWSC)/Crane spec 310 beta glass separator, which is widely used in Li_4SOCl_2 commercial cells, was found to evolve gas for over 500 hours at 25°C.⁷⁴ The pressure of the gas evolved was measured and the results indicated that the evolved hydrogen gas could provide a pressure buildup of 33 psi in a 10,000 Ah MESP cell after 15 hours at 25°C.

Once safety is built into the design, a comprehensive in-process quality control of all production and assembly steps is required to assure a reliable, consistent, safe product. This includes calibration of all instruments and production equipment on a regular basis, adequate piece part inspection and analysis of materials, and qualification of operators. In-depth training of all production and quality control personnel will provide the additional eyes and ears to catch nonconforming items, note changes in components and products, and, most importantly, identify safety issues. This entire quality process must be supported by configuration control management, which evaluates all changes and assures that the process is on course as given in the evaluates all changes and assures that the process is on course as given in the manufacturing control documents.

The inspection and acceptance of the final product require a comprehensive quality plan to assure product consistency and reliability. Qualification (or certification) of the product depends for the most part on the application and is a matter of the user and manufacturer to settle before the design is accepted. Acceptance is the manufacturer's responsibility and signifies his approval that the product meets the standards and operational requirements specified. This includes a large variety of testing at various temperatures and rates. It also includes nondestructive tests, sometimes at the 100-percent inspection level (e.g., weights) and also other tests.

Qualification tests are more specific to the application and are used to verify that the manufacturer has met customer requirements. Extended electrical, thermal, and structural testing will be considered part of the package. A complete series of tests, in theory, would have to be performed only once to obtain the baseline information. Future procurements would involve only sample testing to verify that the baseline has not changed.

SECTION 7

RECOMMENDATIONS FOR IMPROVING THE SAFETY OF Li-SOCl₂ CELLS

The safety problems of Li-SOCl₂ cells are due basically to the high reactivity of the system and the low melting point of Li, toxic nature of SOCl₂ and some of the discharge products, and poor electrical conductivity of the electrolyte. A lack of complete understanding of the cell chemistry and its operating requirements and deficiencies in cell design, manufacture, and quality control have also contributed to the unsafe behavior. Many of these issues are solvable. Improvements in the following areas are suggested to assure the safe use of the Li-SOCl₂ cell: 1) fundamental understanding, 2) cell design, 3) quality control, and 4) user education. These issues are discussed in detail below.

7.1 FUNDAMENTAL UNDERSTANDING

Fundamental studies have been conducted to better understand cell chemistry. However, there are a number of issues still unresolved with respect to safety. They are:

1. Extending the understanding of cell chemistry during discharge and reversal to higher discharge rates and low and high temperatures.
2. Investigating the role of intermediates in the safety of the cells. Reduction of SOCl₂ is supposed to take place through a series of intermediates. These intermediates may be hazardous. Further work is needed to confirm their presence, determine their stability at various conditions, and establish their role in cell safety.
3. Ascertaining whether Li₂O₂ is present. Li₂O₂ reportedly is formed during discharge and forced over-discharge. The presence of this material is suggested based on X-ray diffraction results. Additional information is needed to confirm or refute the formation of this material and its impact on cell safety.
4. Evaluating the chemistry of starved cells. Most commercial cells appear to be working in or near electrolyte-starved conditions; hence, a study of the chemistry of starved cells may lead to the understanding of cell safety issues. To date, most research has been done on flooded cells.
5. Arriving at a better understanding of the chemistry of the cells during carbon-limited voltage reversal and its impact on cell safety. Further work is needed to resolve many issues of carbon-limited voltage reversal.

6. Improving electrolyte conductivity to improve rated performance and decrease polarization losses.
7. Studying the factors that control the growth of LiCl passive film and modifying the film structure to reduce voltage delay problems without affecting safety.
8. Performing thermal analyses of cells during forced over-discharge and charge.
9. Correlating the characteristics of the carbon electrode with its performance.
10. Determining the influence of additives and catalysts to improve rated performance and cell safety.

7.2 CELL DESIGN

The severity of hazards appears to depend significantly on cell design. Bobbin cells appear to be relatively safe under most operating conditions. Similarly, few unsafe incidents are on record for large prismatic cells. However, mild venting or deformation has been observed when the cells are short circuited. The greatest number of safety problems are reported for AA, C, and D cells having jellyroll electrodes. The unsafe behavior of these cells may be due to inherent design problems or due to the fact that they were used for a wide range of applications beyond their operational capability. Hence, most spirally wound cells are optimized principally for performance. However, what is needed is a safe cell design optimized for endurance. The following issues need detailed investigation in arriving at a safe design for these cells:

- 1) Determining the optimum quantity of SOCl_2 required for safe cell operation. Battery engineers generally provide sufficient SOCl_2 required for normal discharge and a little excess to account for Faradaic inefficiencies. Such a cell may develop dry spots at the end of discharge or reversal, providing a condition that can be very hazardous. For safe operation, adequate quantities of SOCl_2 are needed to account for normal discharge to sustain conductivity during discharge and reversal and to keep the majority of the discharge products in solution.
- 2) Determining the optimum lithium-to- SOCl_2 ratio to assure safety during cell reversal. Optimization of this balance for the operating conditions (rate and temperature) is required to enhance performance and safety.
- 3) Evaluating the pros and cons of prismatic and cylindrical configuration with regard to rate and thermal management.

- 4) Minimizing current distribution problems in the electrodes for improved performance at high discharge rates by additional tabs, connections, or improved substrates.
- 5) Performing thermal analyses of the cell and its components to optimize thermal management.
- 6) Determining the role and stability of the separator and select appropriate separator materials.
- 7) Evaluating glass/metal seal stability and design.
- 8) Considering the use of electronic devices such as fuses and diodes to improve the safety of the cells during short circuit and reversal at the cell or battery level.

7.3 QUALITY CONTROL

The quality of materials and quality control of processes, both manufacturer responsibilities, have been the source of numerous incidents. Hence, quality control of materials and various processes is most essential for assuring a safe product. The following important issues need detailed investigation to evolve a reliable quality control program:

- 1) Determining the effect of moisture in all cell components.
- 2) Determining the effects and limits of exposure of lithium to dry room conditions.
- 3) Determining the effects of impurities in the separator and carbon electrode.
- 4) Optimizing overall quality standards for processing and materials.
- 5) Developing nondestructive techniques for evaluating components and cells.

7.4 USER EDUCATION

Inappropriate or careless applications of Li-SOCl₂ cells have created hazardous situations. For this reason the use of these cells must be limited to appropriate engineering applications where the user is well informed. Further, the user must be educated not only on expected performance but also on the limitations and the hazards associated with lithium batteries. This area is receiving greater attention today than earlier. However, it is probably the most important step that can be taken at this time to avoid a safety problem.

SECTION 8

SUMMARY AND CONCLUSIONS

Li-SOCl₂ cells have many desirable characteristics: high energy density, high operating cell voltage, excellent voltage stability over 95 percent of the discharge regime, ability to operate over a wide temperature range (-40°C to +80°C), exceptionally long storage life, and low cost of materials¹⁻⁵. The performance of this system is far superior to that of other electrochemical systems, and it holds the promise of important weight savings for space operations (Figure 1-1). In spite of these attractive features, the use of these cells in space is currently restricted because of their reported hazardous behavior. The safety issue is of prime concern for spaceflight applications especially when personnel are involved. Unsafe incidents reported so far have ranged from mild venting of toxic materials to violent explosions and fires. All hazardous incidents reported to date may be classified into one of the following categories:

1. Leaking of electrolyte through seals or welds under mild or non-operational conditions.
2. High-pressure venting of internal gases and electrolyte through seal and weld areas.
3. Violent or controlled rupture of a cell case, with the expulsion of toxic materials, sometimes explosively with fire.

The bases for all of these incidents may be related to user- and manufacturer-induced causes. User-induced activities may be attributed to operational, abusive, or handling conditions to which the cell is subjected. Manufacturer-induced hazard conditions may be related to design and/or quality control deficiencies. After a careful analysis, the source of the problems cited above has been classified into user- and manufacturer-induced causes, as described in Figure 4-1.

The user may induce hazards during normal operation if the discharge rate or duty cycle is excessive or if environmental conditions such as temperature, shock, and vibration exceed the cell design operational capability. Hazards may also be induced by electrical abuse; i.e., shortcircuiting, charging and over-discharging, and/or physical abuse (puncturing, crushing, burning, or impact). Finally, the user may abuse a cell by uncontrolled storage, improper transportation, or disposal. Operation of the cells at low discharge rates is generally safe. However, a lack of knowledge or understanding of the safety issues may lead to problems.

Abuse is probably the most prevalent source of Li-SOCl₂ cell hazards.

Many explanations have been offered to explain the unsafe behavior of the cells under the above operating and abuse conditions. The explanations fall into two categories: 1) thermal mechanisms and 2) chemical mechanisms.

However, it is quite difficult to separate the effect of each. The impact of both may be responsible for cell venting or explosion.

Some safety problems encountered with Li-SOCl₂ cells may be attributed to deficiencies in cell design and in quality control during cell fabrication. Bobbin cells appear to be relatively safe under most operating conditions because this type of cell has been designed for low-rate applications. The greatest absolute number of safety problems have been reported for AA, C, and D cells of jellyroll design. However, the percentage of incidents are no greater than those experienced in various alkaline cells during their development.

A well-coordinated basic and applied research program is needed to develop safe Li-SOCl₂ cells. Recommendations to improve the safety of Li-SOCl₂ cells include:

1. Improving the present understanding of the chemistry of Li-SOCl₂ cells.
2. Conducting quantitative modeling of cell and battery behavior.
3. Optimizing cell design for both safety and performance.
4. Implementing effective quality control procedures during cell fabrication.
5. Educating the user.

APPENDIX A
DOT-E 7052
(FIFTEENTH REVISION)



US Department
of Transportation

Research and
Special Programs
Administration

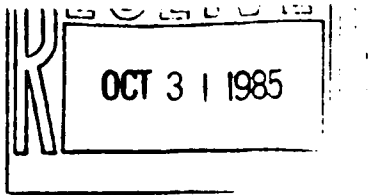

McGinnis
C. Thomas
49th Street, N.W.
Washington, D.C. 20591

DOT-E 7052
(FIFTEENTH REVISION)

1. Power Conversion, Inc., Elmwood, New York, is hereby granted an exemption from those provisions of this Department's Hazardous Materials Regulations specified in paragraph 5 below to offer packages prescribed herein of a certain flammable solid for transportation in commerce subject to the limitations and special requirements specified herein. This exemption authorizes the shipment of lithium batteries and provides no relief from any regulation other than as specifically stated. Each of the following is hereby granted the status of a party to this exemption (SEE APPENDIX I).

2. BASIS. This exemption is based on Power Conversion's application dated February 15, 1984, submitted in accordance with 49 CFR 107.105. The granting of party status is based on the following applications submitted in accordance with 49 CFR 107.111 and the public proceeding thereon (SEE APPENDIX II).

3. HAZARDOUS MATERIALS (Descriptor and class). Lithium batteries and cells containing Metallic lithium, Vanadium pentoxide, Manganese dioxide, Monofluorographite, Sulfur dioxide, Lithium bromide salts, Acetonitrile, or mixtures of Acetonitrile and Propylene carbonate; also lithium batteries and cells containing Lithium metal, a depolarizer such as Titanium disulfide, Thionyl chloride or Sulphuryl chloride or Polycarbonmonofluoride and a Lithium salt such as Lithium tetrachloroaluminate or Lithium perchlorate or Lithium tetrafluoroborate, Lithium molybdenum disulfide and Lithium hexafluoroarsenate, Vanadium pentoxide - classed as flammable solid; devices containing lithium batteries specifically identified to, and acknowledged in writing by, the Office of Hazardous Materials Regulation (OHMR), prior to the first shipment.

This exemption does not authorize the transportation of cells containing lithium metal which have been discharged to the extent that the open circuit voltage is less than two volts, or batteries containing one or more such cells.

4. PROPER SHIPPING NAME (49 CFR 172.101). Lithium batteries.

5. REGULATION AFFECTED. 49 CFR 172.101, 172.420, 175.3.

6. MODES OF TRANSPORTATION AUTHORIZED. Motor vehicle, rail freight, cargo vessel and cargo-only aircraft.

7. SAFETY CONTROL MEASURES. Packaging prescribed is as follows:

a. Cells and batteries must be packed in strong inner fiberboard containers limited to a maximum of 500 grams of lithium in one inner container. No cell containing more than 12 grams of lithium may be shipped under this exemption.

b. When drums are used, the inner containers must be separated from each other and all inner surfaces of the drum by at least one inch thickness of vermiculite or other equivalent noncombustible cushioning materials.

APPENDIX A
DOT-E 7052
(FIFTEENTH REVISION)



US Department
of Transportation

Research and
Special Programs
Administration

OCT 3 1 1985

M. Crum
C. Thomas

49 CFR 172.101, 172.420, 175.3
Washington, D.C. 20590

DOT-E 7052
(FIFTEENTH REVISION)

1. Power Conversion, Inc., Elmwood, New York, is hereby granted an exemption from those provisions of this Department's Hazardous Materials Regulations specified in paragraph 5 below to offer packages prescribed herein of a certain flammable solid for transportation in commerce subject to the limitations and special requirements specified herein. This exemption authorizes the shipment of lithium batteries and provides no relief from any regulation other than as specifically stated. Each of the following is hereby granted the status of a party to this exemption (SEE APPENDIX I).

2. BASIS. This exemption is based on Power Conversion's application dated February 15, 1984, submitted in accordance with 49 CFR 107.105. The granting of party status is based on the following applications submitted in accordance with 49 CFR 107.111 and the public proceeding thereon (SEE APPENDIX II).

3. HAZARDOUS MATERIALS (Descriptor and class). Lithium batteries and cells containing Metallic lithium, Vanadium pentoxide, Manganese dioxide, Monofluorographite, Sulfur dioxide, Lithium bromide salts, Acetonitrile, or mixtures of Acetonitrile and Propylene carbonate; also lithium batteries and cells containing Lithium metal, a depolarizer such as Titanium disulfide, Thionyl chloride or Sulphuryl chloride or Polycarbonmonofluoride and a Lithium salt such as Lithium tetrachloroaluminate or Lithium perchlorate or Lithium tetrafluoroborate, Lithium molybdenum disulfide and Lithium hexafluoroarsenate, Vanadium pentoxide - classed as flammable solid; devices containing lithium batteries specifically identified to, and acknowledged in writing by, the Office of Hazardous Materials Regulation (OHMR), prior to the first shipment.

This exemption does not authorize the transportation of cells containing lithium metal which have been discharged to the extent that the open circuit voltage is less than two volts, or batteries containing one or more such cells.

4. PROPER SHIPPING NAME (49 CFR 172.101). Lithium batteries.

5. REGULATION AFFECTED. 49 CFR 172.101, 172.420, 175.3.

6. MODES OF TRANSPORTATION AUTHORIZED. Motor vehicle, rail freight, cargo vessel and cargo-only aircraft.

7. SAFETY CONTROL MEASURES. Packaging prescribed is as follows:

a. Cells and batteries must be packed in strong inner fiberboard containers limited to a maximum of 500 grams of lithium in one inner container. No cell containing more than 12 grams of lithium may be shipped under this exemption.

b. When drums are used, the inner containers must be separated from each other and all inner surfaces of the drum by at least one inch thickness of vermiculite or other equivalent noncombustible cushioning materials.

- c. Inside boxes must be further overpacked as specified in paragraphs (8c) or (8d).
- d. Packages must be marked as prescribed in Subpart "D" of 49 CFR Part 172. Packages must be labeled with the FLAMMABLE SOLID label shown in 49 CFR 172.420.
- e. Each cell and battery must be equipped with an effective means of preventing external short circuits.
- f. Each cell and battery must incorporate a safety venting device or be designed in such a manner that will preclude a violent rupture under any condition incident to transportation such as a "dead short". The design of cells and batteries not equipped with a safety venting device must be specifically identified to this office prior to the first shipment of package. Batteries containing cells or series of cells connected in parallel must be equipped with diodes to prevent reverse current flow.
- g. Three representative cells must be taken from each week's production of each cell type and be subjected to the test prescribed in section 3.2.1(1) of Appendix B, Report ECOM730242F on file with the OHMR.
- h. One representative battery must be taken from each week's production of each battery type and must be subjected to the test prescribed in Section 3.2.2(1) of the above referenced report.
- i. At least 10 cells and one battery of each type of each week's production must be subjected to a thermal stability test at 75°C., for 48 hours and show no evidence of distortion, leakage or internal heating.

8. SPECIAL PROVISIONS.

- a. Persons who receive cells and batteries covered by this exemption may reship them pursuant to the provisions of 49 CFR 173.22a in any of the packagings authorized in this exemption including those in which they were received.
- b. A copy of this exemption must be carried aboard each vessel and aircraft used to transport packages covered by this exemption.
- c. For shipment by cargo-only aircraft, the outside container must be a removable head drum of the DOT Specification 17H or 17C series (or equivalent) and be equipped with a gastight gasket.
- d. For shipment by water, motor vehicle, rail freight, the outside container must be either (1) strong wooden box, (2) DOT Specification 12B fiberboard box (or equivalent), (3) DOT Specification 21C fiber drum, or equivalent, or (4) metal drum as authorized in paragraph (c) above.

e. Cells containing no more than 12 grams of lithium metal and also containing lithium molybdenum disulfide and lithium hexafluoroarsenate or vanadium pentoxide, polycarbonmonofluoride, manganese dioxide, titanium disulfide, thionyl chloride and lithium tetrachloroaluminate, lithium tetrafluoroborate or acetonitrile and sulfur dioxide, or thionyl chloride/bromine complex or sulfuryl chloride and chlorine which are hermetically sealed, and batteries constructed of such cells, are excepted from the requirements of 7.g., 7.h., 7.i. and 8.c., of this exemption when in compliance with the following:

Prior to the first shipment, 10 cells or 4 batteries of each type to be offered for transportation must be tested as follows, without showing any evidence of out-gassing, leakage, loss of weight, or distortion:

- i. The cells or batteries shall be stored for 6 hours at a pressure corresponding to an altitude of 50,000 feet at 24 ± 4 C.
- ii. The cells or batteries shall then be subjected to the thermal stability test at 75 C for 48 hours as required in paragraph 7.i.
- iii. The cells or batteries shall be rigidly clamped to the platform of a vibration machine. A simple harmonic motion having an amplitude of 0.03 inch (0.06 inch maximum total excursion) shall be applied. The frequency shall be varied at the rate of 1 cycle per second per minute between the limits of 10 and 55 cycles per second. The entire range of frequencies and return shall be traversed in 95 ± 5 minutes for each of three mutually perpendicular mounting positions of the battery and two perpendicular positions of the cells. One of the directions of vibration shall be perpendicular to the terminal face of the battery or cell. Open circuit voltage shall be observed for 30 seconds during the last quarter of each vibration period. Periodic retesting is not required.
- iv. The batteries (not cells) must be subjected to a shock test as follows:

The battery shall be secured to the testing machine by means of a rigid mount which will support all mounting surfaces of the battery. Each battery shall be subjected to a total of three shocks of equal magnitude. The shocks shall be applied in each of three mutually perpendicular directions. Each shock shall be applied in a direction normal to a face of the battery. For each

shock, the battery shall be accelerated in such a manner that during the first 3 milliseconds the minimum average acceleration is 75 gravity units (G). The peak acceleration shall be between 125 and 175 G. Cells and batteries meeting the requirements of this paragraph must be packaged in accordance with 7.a., and 8.d. of this exemption.

f. Packagings or shipping paper bearing the former proper shipping name "Lithium metal in cartridges" or "Batteries containing lithium metal" prior to the issue date of the sixth revision may be used until stocks are depleted.

g. For transportation by motor vehicle, the labeling requirements in paragraph 7.d. of this exemption do not apply to package(s) containing lithium/manganese dioxide batteries provided:

1. the batteries contain no more than 4 cells with each cell containing not more than 0.5 grams of lithium, and

2. the gross weight of a package(s) in one motor vehicle does not exceed 65 pounds.

h. This exemption also constitutes the approval of the appropriate authority of the United States for shipment of these batteries on cargo aircraft pursuant to Special Provision A2 of the International Civil Aviation Organization (ICAO) Technical Instructions.

i. The "FLIGHTS OF CARGO-ONLY AIRCRAFT" requirements of Appendix B to 49 CFR Part 107 do not apply to operations subject to this exemption.

9. REPORTING REQUIREMENTS.

a. Any incident involving loss of contents of the packages must be reported to the OHMR as soon as practicable.

b. Test data obtained under 7.g., 7.h., and 8.e. of this exemption must be kept on file and be made available upon request by the OHMR.

10. EXPIRATION DATE. January 15, 1986.

Issued at Washington, D.C.:

Alan I. Roberts
Associate Director for
Hazardous Materials Regulation
Materials Transportation Bureau

AUG 22 1985

(DATE)

Address all inquiries to: Associate Director for Hazardous Materials Regulation, Materials Transportation Bureau, Research and Special Programs Administration, U.S. Department of Transportation, Washington, D.C. 20590. Attention: Exemptions Branch.

APPENDIX I

Honeywell Incorporated, Horsham, Pennsylvania - PTE-1
Duracell International Inc., Terrytown, N.Y. (formerly Mallory Battery Co.,
Tarrytown, N.Y.) - PTE-2
Eagle-Picher Industries, Inc., Joplin, Missouri - PTE-3
GTE Products Corp., Waltham, Massachusetts - PTE-4
U.S. Department of Defense, Washington, D.C. - PTE-5
Ray-O-Vac Corporation, Madison, Wisconsin - PTE-6
U.S. Department of Energy, Washington, D.C. (including its contractor Sandia
Laboratories, Albuquerque, New Mexico) - PTE-7
National Aeronautics and Space Administration, Washington, D.C. - PTE-8
The Boeing Company, Seattle, Washington - PTE-9
Jet Propulsion Laboratory, Pasadena, California - PTE-10
Bunker Ramo Corporation, Westlake Village, California - PTE-11
ENDECO, Inc., Marion, Massachusetts - PTE-12
Gould Inc., Andover, Massachusetts - PTE-13
Electrochem Industries, Inc., Clarence, N.Y. - PTE-14
EG&G Environmental Equipment, Herndon, Va. - PTE-15
Sonatech. Inc., Goleta, Ca. - PTE-16
Altus Corporation, Palo Alto, Ca. - PTE-17
Rockwell International Corporation, Anaheim, Ca. - PTE-18
Plainview Electronics, Corp., Plainview, N.Y. - PTE-19
Hazeltine Corp., Braintree, Ma. - PTE-20
Magnavox Government & Industrial Electronics Co., Ft. Wayne, Inc. - PTE-21
Industrial Solid State Controls, Inc., York, Pa. - PTE-22
Geophysical Research Corporation, Tulsa, OK - PTE-23
Northrop Corporation, Hawthorne, CA - PTE-24
A/S Hellesens (Hellesens Battery Engineering, Inc., Hyde Park, MA) - PTE-25
NL Industries, Houston, TX - PTE-26
Saft America, Inc., Cockeysville, MD - PTE-27
In-Situ, Inc., Laramie, WY - PTE-28
Technical Oil Tool Corp., Norway, OK - PTE-29
DME Corporation, Pompano Beach, FL - PTE-30
Cubic Defense Systems, San Diego, CA - PTE-31
Massachusetts Institute of Technology, Lexington, MA - PTE-32
Gearhart Industries, Inc., Fort Worth, TX - PTE-33
Hercules, Incorporated, Wilmington, DE - PTE-34
Moli Energy Limited, Burnaby, BC, Canada - PTE-35
Kearney & Trecker Corp., Milwaukee, WI - PTE-36
McDonnell Douglas Corp., St. Louis, MO - PTE-37
Ocean Technology, Inc., Burbank, CA - PTE-38
EIC Laboratories, Inc., Norwood, MA - PTE-39
Teledyne Electronics, Newbury Park, CA - PTE-40
Sippican Ocean Systems, Inc., Marian, MA - PTE-41
Martin Marietta Corp., Denver, CO. - PTE-42
Eastman Kodak Co., Rochester, N.Y. - PTE-43
Tracor Applied Sciences, Inc., Rockville, MD - PTE-44

TNR Technical, Inc., Farmingdale, N.Y. - PTE-45
General Motors Corp., Warren, MI - PTE-46
AVCO, Wilmington, MA - PTE-47
General Electric Co., Philadelphia, PA. - PTE-48
ENMET Corporation, Ann Arbor, MI - PTE-49
Tadiran - Israel Electronics Industries, Ltd. (U.S. agent Tadiran (U.S.) Inc.),
Woodland Hills, CA. - PTE-50
Pointer, Inc., Temple, Arizona - PTE-51
Bren-Tronics, Inc., Commack, N.Y. - PTE-52
Allen-Bradly, Co., Milwaukee, WI - PTE-53
Panasonic Industrial Co., Secaucus, N.J. - PTE-54
Matsushita Battery Industrial Co., Ltd. (U.S. agent) Weil, Gotshol & Manges,
Wash., D.C. - PTE-55
Leigh Instruments, Ltd., Ontario, Canada (U.S. agent) NAECO Assoc. - PTE 56
Sparton Corp., Jackson, MI - PTE-57
Ferranti, O.R.E., Inc., Falmouth, MA - PTE-58
Union Carbide Corp., Danbury, CT - PTE-59
Halliburton Services, Duncan, OK - PTE-60
General Dynamics, Fort Worth, TX - PTE-61
Motorola, Inc., Schaumburg, IL - PTE-62
Singer Company American Meter Division, Philadelphia, PA - PTE-63
Ballard Technologies Corporation, North Vancouver, Canada (U.S. Agent)
Dr. Lynn Marcoux, Tustin, CA) - PTE-64

APPENDIX II

Honeywell Inc.'s application dated February 7, 1984
Duracell International Inc.'s application dated January 9, February 3, 1984
and July 31, 1985
Eagle-Picher Industries, Inc.'s application dated March 14, 1984
GTE Products Corporation's application dated March 22, 1984
U.S. Department of Defense's application dated January 19, 1984
Ray-O-Vac Corporation's application dated February 27, 1984
U.S. Department of Energy's application dated January 12, 1984
National Aeronautics and Space Administration's application dated March 13,
1984
The Boeing Company's application dated March 6, 1984
Jet Propulsion Laboratory's application dated February 3, 1984
Bunker Ramo Corporation's application dated February 28, 1984
ENDECO, Inc.'s application dated February 27, 1984
Gould, Incorporated's application dated January 26, 1984
Electrochem Industries, Incorporated's application dated March 14, 1984
EG&G Environmental Equipment's application dated January 23, 1984
Sonatech, Incorporated's application dated January 20, 1984
Altus Corporation's application dated January 26, 1984
Rockwell International Corporation's application dated February 29, 1984
Plainview Electronics Corporations' application dated March 9, 1984
Hazeltine Corporation's application dated March 15, 1984
Magnavox Government & Industrial Electronics Co's application dated February 3,
1984
Industrial Solid State Controls, Incorporated's application dated February 6,
1984
Geophysical Research Corporation's application dated March 5, 1984
Northrop Corporation's application dated February 7, 1984
A/S Hellesens - Hellesens Battery Engineering, Incorporated's application
dated February 2, 1984
NL Industries's application dated February 10, 1984
Saft America Incorporated's application dated March 29, 1984
In-Situ, Incorporated's application dated February 3, 1984
Technical Oil Tool Corporation's application dated March 27, 1984
DME Corporation's application dated March 8, 1984
Cubic Corporation's application dated March 15, 1984
Massachusetts Institute of Technology's application dated March 28, 1984
Gearhart Industries, Incorporated's application dated February 24, 1984
Hercules Incorporated's application dated February 7, 1984
Moli Energy Limited's application dated December 2, 1983
Kearney & Trecher Corporation's application dated December 3, 1983
McDonnell Douglas Corporation's application dated December 23, 1983
Ocean Technology, Incorporated's application dated January 19, 1984
EIC Laboratories, Incorporated's application dated February 8, 1984
Teledyne Electronics application ated February 9, 1984
Sippican Ocean Systems, Incorporated's application dated March 15, 1984

Martin Marietta Corporation's application dated February 20, 1984
Eastman Kodak Company's application dated May 4, 1984
Tracor Applied Sciences, Inc's application dated June 7, 1984
TNR Technical, Inc.'s application dated April 16, 1984
General Motors Corp's application dated April 10, 1984
AVCO's application dated April 24, 1984
General Electric Company's application dated March 26, 1984
ENMET Corporation's application dated March 28, 1984
Tardiran-Isreal Electronic Industries, Limited's application dated May 9, 1984
Pointer, Incorporated's application dated June 25, 1984
Bren-Tronics, Inc's application dated July 16, 1984
Allen-Bradley Company's application dated July 23, 1984
Panasonic Industries Company's application dated June 29, 1984
Matsushita Battery Industrial Co., Limited's application dated June 29, 1984
Lehigh Instruments, Ltd's application dated May 14, 1984
Spartan Corporation's application dated May 18, 1984
Ferranti, O.R.E., Inc's application dated June 7, 1984
Union Carbide Corporation's application dated September 24, 1984 and July 29, 1985
Halliburton Services' application dated October 10, 1984
General Dynamics' application dated October 16, 1984
Motorola, Incorporated's application dated November 14, 1984
Singer Company's application dated November 14, 1984
Ballard Technologies Corporation's application dated November 22, 1984

APPENDIX B

REFERENCES

1. J.J. Auburn, K.W. French, S.I. Liberman, V.K. Shah, and A. Heller, Journal of the Electrochemical Society, **120**, 1613 (1973).
2. W.K. Behl, J.A. Christopoulos, R. Ramirez, and S. Gilman, *ibid.* **120**, 1619 (1973).
3. J.P. Gabano, French patent 2,079,744 (1971).
4. G.E. Blomgren and M.L. Kronenberg, German Patent 2,262,256 (1972).
5. N. Marincic, J. Epstein, and F. Goebel, Proceedings of the 26th Power Sources Symposium **26**, 51 (1974).
6. C. R. Schlaikjer, "Outline of Primary Inorganic Batteries," Proceedings of the Second International Conference on Lithium Batteries, Boca Raton, Florida (March 1985).
7. A.N. Dey, "Sealed Primary Lithium-Inorganic Electrolyte Cell," final report, ERADCOM-TR-74-0109F (July 1978).
8. L.J. Johnson and A.H. Willis, Proceedings of the 29th Power Sources Symposium, **29**, 138 (1980).
9. N. Marincic, "Modern Aspects of Electrochemistry," Vol. No. 15, edited by White J.O.M. Bockris and B. E. Conway, Plenum Press, New York, 167 (1983).
10. C.R. Schlaikjer, "Lithium Batteries," edited by J.P. Gabano, Academic Press London, 303 (1983).
11. F.W. Dampier, "Lithium-Thionyl Chloride Cell System Safety Hazard Analysis," AFWAL-TR-84-2112 (1985).
12. J.R. Driscoll, G.L. Holleck, and D.E. Toland, Proceedings of the 27th Power Sources Symposium, **27**, 28 (1974).
13. C.R. Schlaikjer, F. Gobel, and N. Marincic, Journal of the Electrochemical Society, **126**, 513 (1979).
14. W.L. Bowden and A.N. Dey, Journal of the Electrochemical Society, **127**, 1419 (1980).
15. G.E. Blomgren, V.Z. Leger, T. Kalnoki-kis, M.L. Kronenberg, and R.J. Brodd, Power Sources, **7**, 583 (1979).

16. B.J. Carter, R.M. Williams, A. Rodriguez, F.D. Tsay, and H. Frank, Journal of the Electrochemical Society, Extended Abstract No. 293, 812-2, 162nd ECS Meeting, Detroit, Michigan (October 1982).
17. E. Peled and H. Straze, Journal of the Electrochemistry Society, 124, 1030 (1977).
18. J. Marincic, Proceedings of the 1982 Goddard Space Flight Center Battery Workshop, NASA Conference Publication 2263, 3 (1982).
19. V. Ang, R. Banes, B. Carter, S. Dawson, H. Frank, G. Halpert, S. Subbarao, and L. Whitcanack presentation at the Li-DoD Safety Committee meeting, San Diego, California, (February 1985).
20. A.N. Dey, U.S. Army Report No. ECOM 74-0109F (October 1974).
21. a) R.C. McDonald, Journal of the Electrochemical Society, 129, 24445E (1982).
b) "Inorganic Electrolytes," final report from GTE Laboratories to ONR, Contract No. N00014-76-C-05241, (January 1979).
22. K. M. Abraham (unpublished results).
23. N. Marincic, A. Lombardi, and C.R. Schlaikjer, Proceedings of the 27th Power Sources Symposium, 27, 37 (1976).
- 24a. H. Frank, "Correlation of Design with Performance of Primary Li-SOCl₂ Cells," JPL Publication 82-30, (June 1982).
- 24b. Young I. Cho, S. Subbarao, J. Rowlette, and G. Halpert, Extended Abstracts, 165th ECS meeting of the Electrochemical Society, Las Vegas, Abstract No. 108 (1985).
25. A.N. Dey, Proceedings of the 28th Power Source Symposium, 28, 251 (1978).
26. D.L. Chua and S.L. Deshpande, Proceedings of the Symposium on Battery Design and Optimization, edited by Sidney Gross, the Electrochemical Society, Battery Division, Proceedings, Vol. 79-1, 365 (1979).
27. S. Dallek, S.D. James, and W.P. Kilroy, Journal of the Electrochemical Society, 128, 508 (1981).
28. A.N. Dey and P. Bro, Journal of Electrochemical Society, 125, 1574 (1978).
29. R. Williams, F. Tsay, S. Kim, M. Evans, Q. Kim, A. Rodriguez, B.J. Carter, and H. Frank, Proceedings of the Symposium on Lithium Batteries, edited by A.N. Dey, Electrochemical Society, Battery Div. Proc., Vol. 84-1, 60, (1984).

30. W.K. Istone and R.J. Brodd, Journal of the Electrochemical Society, 131, 2467 (1984).
31. B.J. Carter, S. Subbarao, R.M. Williams, M. Evans, S. Kim, and F.D. Tsay, Proceedings of the 31st Power Source Symposium, 31, 400 (1984).
32. A.I. Attia, "Investigation of Lithium Thionyl Chloride Battery Safety Hazards, Final Report," for the period 28 Sept. 1981 to 31st Dec. 1982, Contract No. 60921-81-C086, prepared for Naval Surface Weapons Center, Gould Research Center Internal Report Number 838-012 (1983).
33. F.W. Dampier and R.C. McDonald, Proceedings of the Symposium on Lithium Batteries, 84-1, 154 (1984).
34. A.N. Dey and C.R. Schlaikjer, Proceedings of the 26th Power Sources Symposium, 26, 47 (1974).
35. A.N. Dey, P.R. Mallory Company, Interim Report, ECOM-74-0104-13 (November 1977).
36. N. Marincic and A. Lombardi, GTE Laboratory, Final Report, ECOM-74-0108-F (April 1977).
37. A.N. Dey, J. Power Sources, 5, 57-72 (1980).
38. J.F. McCartney, A.M. Willis and W.J. Sturgen, Proceedings of 29th Power Sources Symposium, 29, 159 (1980).
39. A.N. Dey, Proceedings of the 27th Power Sources Symposium, 26, 42 (1976).
40. S. Subbarao and G. Halpert, "Safety of Li-SOCl₂ Cells," presentation at 1984 Goddard Space Flight Center (GSFC) Workshop, Washington, D.C., (Proceedings in press) (1984).
41. A.N. Dey and J. Miller, Journal of the Electrochemical Society, 126, 1445 (1979).
42. K.Y. Kim, H.V. Venkatesh, and D.L. Chua, Proceedings of the 29th Power Sources Symposium, 29, 125 (1980).
43. G. Halpert, V. Ang, R. Banes, S. Dawson, H. Frank, S. Subbarao, and L. Whitcanack, presentation at the 1984 GSFC Battery Workshop, Washington, D.C., (November 1984).
44. F. Goebel, Proceedings of the 1983 Goddard Space Flight Center Battery Workshop, NASA Conference Publication, NASA CP 2331 64 (1983).
45. N. Marincic and F. Gobel, J. Power Sources, 5, 73 (1980).
46. K.F. Garoattg and D.L. Chau, Proceedings of the 29th Power Sources Symposium, 29, 153 (1980).

47. M. Babai, "Progress in Batteries and Solar Cells," Japanese Electrochemical Society Press Inc., 3, 110 (1980).
48. J. Epstein and N. Marincic, Proceedings of the Symposium on Lithium Batteries, edited by A.N. Dey, Electrochemical Society, Battery Division, Proceedings, Volume 84-1, 206 (1984).
49. E. Peled, A. Lombardi, and C.R. Schlaikjer, Journal of the Electrochemical Society, 130, 1365 (1983).
50. W.L. Bowden, J.S. Miller, D. Cubbison, and A.N. Dey, "New Electrolyte Salts for Li/SOCl₂ Cells, Proceedings of the Symposium on Lithium Batteries, Electrochemical Society, Vol. 84-1, 80-89 (1984).
51. K.M. Abraham et al., Proceedings of the 28th Power Sources Symposium, 28, 255 (1976).
52. A.N. Dey, Report DELET-TR-74-0109F, Fort Monmouth, New Jersey.
53. A.N. Dey, Journal of the Electrochemical Society, 123, 1262 (1976).
54. K.M. Abraham and R.M. Mank, Journal of the Electrochemical Society, 127, 2091 (1980).
55. K.M. Abraham, G.I. Holleck, and S.B. Brummer, "Battery Design and Optimization," edited by Sidney Gross, The Electrochemical Society, Battery Division, Proceedings Vol. 79-1, 356 (1979).
56. B.J. Carter, M. Evans, S. Subbarao, and R.M. Williams, Extended Abstracts of ECS meeting of 164th meeting of the Electrochemical Society, New Orleans, Louisiana, Abstract No. 149, 84-2 (1984).
57. S. Subba Rao, B. Carter, V. Ang, D. Shen, R. Williams, and G. Halpert, "Influence of rate and Temperature on the Chemistry of Carbon Limited Voltage Reversal," Extended Abstracts of ECS meeting of 165th meeting of Electrochemical Society, Las Vegas, Abstract No. 106 (1985).
58. R.C. McDonald, F.W. Dampier, R. Wang, and J.M. Bennet, "Investigation of Lithium-Thionyl Chloride Battery Safety Hazards," Report N60921-81-R-0190 for NSWC (January 1983).
59. M. Domeniconi, Proceedings of the 1982 Goddard Space Flight Center Battery Workshop, Conference Publication 2263, 67, (1982).
60. S.D. James, P.H. Smith, and W.P. Kilroy, Journal of the Electrochemical Society, 130, 2037 (1983).
61. D.J. Salmon et al., Journal of the Electrochemical Society, 129, 2496, (1982).

62. B.J. Carter, R.M. Williams, M. Evans, O. Kim, S. Kim, F.D. Tsay, H. Frank, and I. Stein, "Proceedings of the Symposium on Lithium Batteries," edited by A.N. Dey, The Electrochemical Society, Battery Division, Proceedings, Volume 84-1, 162 (1984).
63. K.M. Abraham, Proceedings of the 1982 Goddard Space Flight Center Battery Workshop, NASA Conference Publication 2263, 58 (1982).
64. D.I. Chua, J.O. Crabb, and S.L. Deshpande, Proceedings of the Power Source Symposium, 28, 247 (1980).
65. N. Doddapaneni, Proceedings of the Symposium on Lithium Batteries, edited by A.N. Dey, The Electrochemical Society, Battery Division, Proceedings, Vol. 84-1, 146 (1984).
66. D.H. Johnson, Proceedings of the 1982 Goddard Space Flight Center Battery Workshop, NASA Conference Publication 2263, 75 (1982).
67. C.C. Liang, P.W. Krehl, and D.A. Danner, Journal of Applied Electrochemistry, Vol. 11, 563-571 (1981).
68. M. Eisenberg, U.S. Patent 3.891.458.
69. Michael J. Brookman, "Handling Lithium Batteries at the Factory," Components (1984).
70. G. Halpert and J. Rowlette, "The Battery Safety Handbook," (JPL internal report).
71. W.V. Zajac Jr., Abstract 13, Electrochemical Society fall meeting (1981).
72. N. Marincic, R.C. McDonald, and J.S. Shambaugh, Abstract 15, Electrochemical Society fall meeting (1981).
73. R.C. McDonald, F. Goebel, J.S. Shambaugh and M.A. Slavin, Abstract 16, Electrochemical Society fall meeting (1981).
74. J.J. Auborn and H. Venkatesetty in "Lithium Battery Technology", edited by H. V. Venkatesetty, John Wiley & Sons, New York, 127 (1984).
75. W. Clark, F. Dampier, A. Lomabardi, and T. Cole, "Lithium Cell Reactions," Report A, Final-TR-83-2083 (December 1983).
76. S. Subbarao, H. Frank, Proceedings of the 1983 Goddard Space Flight Center Battery Workshop, NASA Conference Publication, NASA CP-2331, 97 (1983).