

NASA Contractor Report 178259

ICASE REPORT NO. 87-10

ICASE

INVERSE PROBLEMS IN THE MODELING OF
VIBRATIONS OF FLEXIBLE BEAMS

H. T. Banks
R. K. Powers
I. G. Rosen

Contracts No. NAS1-17070, NAS1-18107
February 1987

(NASA-CR-178259) INVERSE PROBLEMS IN THE
MODELING OF VIBRATIONS OF FLEXIBLE BEAMS
Final Report (NASA) 24 p CSDL 12A

N87-20777

Unclas
G3/64 45172

INSTITUTE FOR COMPUTER APPLICATIONS IN SCIENCE AND ENGINEERING
NASA Langley Research Center, Hampton, Virginia 23665

Operated by the Universities Space Research Association

NASA

National Aeronautics and
Space Administration

Langley Research Center
Hampton, Virginia 23665

**INVERSE PROBLEMS IN THE MODELING OF
VIBRATIONS OF FLEXIBLE BEAMS⁺**

H. T. Banks^{*}
Center for Control Sciences
Division of Applied Mathematics
Brown University
Providence, RI 02912

R. K. Powers
Department of Mathematics and Statistics
University of Arkansas
Fayetteville, AK 72701

I. G. Rosen^{**}
Department of Mathematics
University of Southern California
Los Angeles, CA 90089

ABSTRACT

The formulation and solution of inverse problems for the estimation of parameters which describe damping and other dynamic properties in distributed models for the vibration of flexible structures is considered. Motivated by a slewing beam experiment, the identification of a nonlinear velocity dependent term which models air drag damping in the Euler-Bernoulli equation is investigated. Galerkin techniques are used to generate finite dimensional approximations. Convergence estimates and numerical results are given. The modeling of, and related inverse problems for the dynamics of a high pressure hose line feeding a gas thruster actuator at the tip of a cantilevered beam are then considered. Approximation and convergence are discussed and numerical results involving experimental data are presented.

⁺Invited lecture, Conference on Control Theory for Distributed Parameter Systems and Applications, Vorau, Austria, July 7-11, 1986.

Part of this research was supported under the National Aeronautics and Space Administration under NASA Contracts No. NAS1-17070 and NAS1-18107 while the authors were visiting scientists at the Institute for Computer Applications in Science and Engineering (ICASE), NASA Langley Research Center, Hampton, VA.

^{*}This research was supported in part by the National Science Foundation under NSF Grant MCS-8504316, the Air Force Office of Scientific Research under Contract AFOSR-84-0398, and the National Aeronautics and Space Administration under NASA Grant NAG-1-517.

^{**}This research was supported in part by the Air Force Office of Scientific Research under Contract AFOSR-84-0393.

1. Introduction

The purpose of this note is to illustrate and explain some of the ideas underlying the use of parameter estimation techniques in investigating damping and other dynamic phenomena in several classes of distributed models for flexible structures. We do this in the context of two specific examples drawn from experimental structures. In the first example we present techniques and results that can be used to study nonlinear aspects of viscous damping (nonlinear air drag) in slewing maneuvers with flexible beam like structures. We shall describe some fundamental questions, present a model for which an estimation problem is of importance, and then show how this inverse problem can be approximated for computational purposes. We do this in a weak or variational setting and give convergence arguments to provide a theoretical foundation for the numerical schemes we have used. These convergence results are then followed by presentation of a numerical test example. Our methods have proved useful in current studies with experimental data, the results for which will be presented in detail elsewhere.

In a second example, we outline techniques that have been useful in developing accurate models for the dynamic effects of a flexible gas hose/tip mass/thruster apparatus when it is attached to a flexible beam to provide an active control system (the so-called "RPL experiment"). Since detailed mathematical arguments for this project are given elsewhere [BGRW], we shall only outline the model, the approximation ideas, and present a summary of numerical results obtained when using our general approach with experimental data.

2. Nonlinear Damping in Slewing Maneuvers

In a series of papers [HJ], [JH], [JHR], Juang and his co-workers describe experiments carried out to demonstrate the feasibility of actively controlling (stabilizing) vibrations of a beam during slewing maneuvers. Experiments were conducted with a 1 meter steel beam and with a 3.9 meter aluminum honeycomb solar panel cantilevered in a vertical plane and rotated in the horizontal plane. Each was attached to a torquing motor at the hub of rotation or "root" of the beam. In typical experiments, the beams were slewed 30° to 45° in 1.5 to 4.5 seconds. Strain gauges were located at the root and at .22 and .5 of the length ℓ of the beam. An angle potentiometer (at the root) measured angular displacements during the slew. These measurements (strain, y_{xx} , and angular displacement, θ) were used as feedback to the motor which was then used to suppress the vibrations via an LQR theoretical formulation for the feedback control laws.

A series of slewing maneuver experiments were carried out in a laboratory at NASA Langley Research Center with possible effects due to air damping present. These were then followed by repetition of the experiments in a vacuum chamber. Experiment and theory were in good agreement in the vacuum chamber experiments, but there were significant discrepancies between the theoretical model based simulations and the experimental data obtained in the laboratory setting. It is important

to understand the variation in responses of controlled flexible structures in such differing environments since many future large spacecraft studies will, by necessity, involve model extrapolation and design based on laboratory performance only without the benefit of vacuum chamber comparisons.

It has been suggested that the inaccuracies in the Juang, et. al. simulations most likely resulted from two types of model error: (1) the absence of a viscous damping term to represent the nonlinear air damping and (2) dissipation at the fixed end of the cantilevered beams was not included in the model even though there was some loose "play" in the clamped or "built-in" end of the beams. This latter mechanism for energy absorption presumably should be modeled by some type of nonlinear boundary condition in place of the usual no displacement, no slope boundary conditions: $y = y_x = 0$.

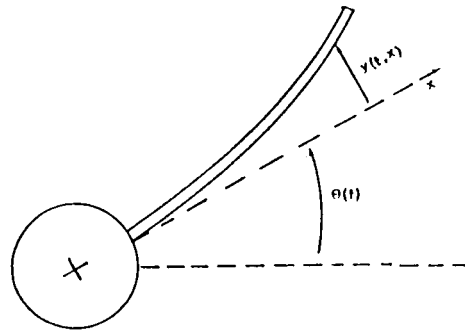

Figure 2.1

Here we focus on a nonlinear air damping component of the model as suggested by Juang, et. al., and show that one might effectively compute this using the experimental data in a least squares setting. We use a formulation proposed by Juang and his co-workers; this model can be derived by combining first principle energy considerations with laboratory findings on nonlinear drag forces. If $\theta(t)$ and $y(t,x)$ denote respectively angular displacement (from some reference angle) at time t and bending deflection along the beam at time t and position x as depicted in Figure 2.1 above, the model including actuator dynamics has the form (see [JHR] for a more detailed discussion)

$$(2.1) \quad \rho \frac{\partial^2 y}{\partial t^2} + \rho x \frac{d^2 \theta}{dt^2} + c_3 f(x) \left(x \frac{d\theta}{dt} + \frac{\partial y}{\partial t} \right) + c_4 \left\{ x \frac{d\theta}{dt} + \frac{\partial y}{\partial t} \right\} + EI \frac{\partial^4 y}{\partial x^4} = 0$$

$$(2.2) \quad I_B \frac{d^2 \theta}{dt^2} + \int_0^\ell \rho x \frac{\partial^2 y}{\partial t^2} dx + \int_0^\ell c_3 f(x) \left(x \frac{d\theta}{dt} + \frac{\partial y}{\partial t} \right) x dx + \int_0^\ell c_4 \left\{ x \frac{d\theta}{dt} + \frac{\partial y}{\partial t} \right\} x dx = \tau(t)$$

$$(2.3) \quad \tau(t) = k_0 e_a(t) - k_1 \frac{d\theta}{dt} - k_2 \frac{d^2 \theta}{dt^2}$$

$$(2.4) \quad y(t,0) = \frac{\partial y}{\partial x}(t,0) = 0, \quad \frac{\partial^2 y}{\partial x^2}(t,\ell) = \frac{\partial^3 y}{\partial x^3}(t,\ell) = 0.$$

Here e_a represents the applied armature voltage (this term involves strain feedback in the control problem), the terms involving c_3 and c_4 represent viscous damping and the coefficients ρ and EI are the usual beam material parameters, linear mass density and flexural stiffness, and I_B is the moment $\int_0^\ell \rho x^2 dx$ about the axis of rotation. The damping function f is assumed to have the form $f(v) = v|v|$ for v in some bounded region. Of course, one can assume without loss of generality based upon physical considerations that f becomes bounded as v becomes large.

A number of state space formulations of this model can be investigated in the context of identification and control problems including the following:

- (i) Both θ and $\dot{\theta} = \frac{d\theta}{dt}$ are treated as states,
- (ii) The time history for θ is assumed known, but $\dot{\theta}$ is treated as a state (if $\theta(t)$ is known from experimental data, it does not follow that $\dot{\theta}(t)$ can be effectively obtained by differentiation of the data),
- (iii) Both θ and $\dot{\theta}$ are measured reliably so that each can be treated as a known quantity.

For our discussions here of estimation of the damping coefficients, we assume that (iii) holds so that one can combine (2.1) and (2.2) to also eliminate $\dot{\theta}$ as an unknown in the model. We do this before formulating a least squares problem for estimation of the damping. We also include a Kelvin-Voigt material damping term in the beam dynamics equation.

We consider then the coupled system (actuator dynamics plus transverse vibrations of the beam) for $0 < x < \ell$, $t > 0$

$$(2.5) \quad \rho y_{tt} + \rho x \ddot{\theta} + c_3 f(x\dot{\theta} + y_t) + c_4 \{x\dot{\theta} + y_t\} + EI D^4 y + c_D I D^4 y_t = 0,$$

$$(2.6) \quad I_B \ddot{\theta} + \int_0^\ell \rho x y_{tt} dx + c_3 \int_0^\ell f(x\dot{\theta} + y_t) x dx + c_4 \int_0^\ell \{x\dot{\theta} + y_t\} x dx = k_0 e_a - k_1 \dot{\theta} - k_2 \ddot{\theta},$$

with appropriate boundary conditions for $t \geq 0$

$$(2.7) \quad y(t,0) = Dy(t,0) = 0,$$

$$(2.8) \quad EI D^2 y(t, \ell) + c_D I D^2 y_t(t, \ell) = 0, \quad EI D^3 y(t, \ell) + c_D I D^3 y_t(t, \ell) = 0,$$

and appropriate initial conditions. Here and below we shall use the notation $D = \partial/\partial x$. Assuming that $\theta(t)$ and $\dot{\theta}(t)$ are known for $0 \leq t \leq T$, where T is the duration of the experiment, we may solve for $\ddot{\theta}$ in equation (2.6), substitute this into equation (2.5), and obtain a single nonlinear partial differential equation for the bending deflection y . Upon doing this we obtain

$$(2.9) \quad \rho y_{tt} + \mathcal{L}(y_{tt}) + c_3 \mathcal{F}_1(t, x, y_t) + c_4 \mathcal{F}_2(t, x, y_t) + g(t, x) + c_3 f(x\dot{\theta} + y_t) + c_4 \{x\dot{\theta} + y_t\} + EI D^4 y + c_D I D^4 y_t = 0$$

where

$$(2.10) \quad \mathcal{L}(y_{tt}) \equiv - \frac{\rho x}{I_B + k_2} \int_0^\ell \rho s y_{tt} ds,$$

$$(2.11) \quad \mathcal{F}_1(t,x,y_t) \equiv - \frac{\rho x}{I_B + k_2} \int_0^\ell f(s\dot{\theta} + y_t) s ds,$$

$$(2.12) \quad \mathcal{F}_2(t,x,y_t) = - \frac{\rho x}{I_B + k_2} \int_0^\ell \{s\dot{\theta} + y_t\} s ds,$$

and

$$(2.13) \quad g(t,x) = - \frac{\rho x}{I_B + k_2} \{k_0 e_a(t) - k_1 \dot{\theta}(t)\}.$$

The boundary conditions (2.7), (2.8) involving no displacement, no slope at $x = 0$ and no moment, no shear at $x = \ell$, can be equivalently written as

$$(2.14) \quad y(t,0) = 0, Dy(t,0) = 0, D^2y(t,\ell) = 0, D^3y(t,\ell) = 0.$$

Using this system, we may formulate an estimation problem for the parameter $q = (q_1, q_2, q_3, q_4) = (EI, c_D I, c_3, c_4)$, given observations $\varepsilon_i, i = 1, \dots, M$, for the root strain $D^2y(t_i, 0)$. The problem becomes one of choosing from some admissible set of parameters $Q \subset \mathbb{R}^4$ (we treat here only the constant parameter case - variable coefficients can be readily treated with appropriate modifications of the arguments - see [BC1], [BC2], [BCR], [BR1] for details) a parameter q^* which minimizes over Q the least squares criterion

$$J(q) = \sum_{i=1}^M |D^2y(t_i, 0; q) - \varepsilon_i|^2$$

where $y(\cdot, \cdot; q)$ is the solution of (2.9), (2.14) for a given set of initial conditions $y(0,x) = \Phi(x)$, $y_t(0,x) = \Psi(x)$. Least squares problems of this type possess a number of interesting aspects (infinite dimensional states, theoretical and computational ill-posedness, etc.) which have been discussed by us and others in a number of previous publications. Here we focus on one particular question: state approximation techniques and the convergence arguments for approximating parameter estimates (these convergence arguments are also an important part of theoretical results which guarantee a type of inverse method stability - i.e. continuous dependence of estimates on the observations - see [B]). Before turning to these convergence arguments, we rewrite the system in a variational form (conservative form) with states $v = y_t, w = D^2y$.

We first rewrite (2.9) as

$$(2.15) \quad \rho v_t + \mathcal{L}(v_t) + q_3 \mathcal{F}_1(t,x,v) + q_4 \mathcal{F}_2(t,x,v) + g \\ + q_3 f(x\dot{\theta} + v) + q_4 \{x\dot{\theta} + v\} + q_1 D^2w + q_2 D^4v = 0$$

$$(2.16) \quad w_t = D^2v$$

$$(2.17) \quad v(0) = \Psi, \quad w(0) = D^2\Phi,$$

where we seek solutions $v \in H^4 \cap H_L^2, w \in H_R^2$ with

$$\begin{aligned} H_L^2 &\equiv \{\varphi \in H^2(0, \ell) \mid \varphi(0) = D\varphi(0) = 0\} \\ H_R^2 &\equiv \{\varphi \in H^2(0, \ell) \mid \varphi(\ell) = D\varphi(\ell) = 0\}. \end{aligned}$$

Then an equivalent weak or variational form is: Find $(v, w) \in H_L^2 \times H^0$ satisfying the initial conditions (2.17) and

$$\begin{aligned} (2.18) \quad & \langle \rho v_t + \mathcal{L}(v_t) + q_3 \mathcal{F}_1(t, \cdot, v) + q_4 \mathcal{F}_2(t, \cdot, v), \varphi \rangle \\ & + \langle g(t, \cdot) + q_3 f(x\dot{\theta} + v) + q_4 \{x\dot{\theta} + v\}, \varphi \rangle + \langle q_1 w + q_2 D^2 v, D^2 \varphi \rangle = 0 \text{ for } \varphi \in H_L^2 \\ (2.19) \quad & \langle w_t - D^2 v, \psi \rangle = 0 \quad \text{for } \psi \in H^0. \end{aligned}$$

We next make the following observations: for each of the terms involving q_4 in equation (2.18), there is an analogue involving q_3 , the difference being that the q_3 terms are nonlinear, the q_4 terms are linear. Since our primary emphasis here is in presenting convergence arguments for estimation of the nonlinear damping coefficients and since these arguments readily extend to the case involving the linear q_4 terms, we, for the sake of exposition, shall assume throughout the remainder of our discussions that $q_4 = 0$. Thus the system of interest to us is

$$\begin{aligned} (2.20) \quad & \langle \rho v_t + \mathcal{L}(v_t) + q_3 \mathcal{F}_1(t, \cdot, v) + q_3 f(x\dot{\theta}(t) + v) + g(t, \cdot), \varphi \rangle \\ & + \langle q_1 w + q_2 D^2 v, D^2 \varphi \rangle = 0 \quad \text{for } \varphi \in H_L^2, \\ (2.21) \quad & \langle w_t - D^2 v, \psi \rangle = 0 \quad \text{for } \psi \in H^0, \\ (2.22) \quad & v(0) = \Psi, \quad w(0) = D^2 \Phi. \end{aligned}$$

We approximate the system via the usual Galerkin procedures by choosing finite dimensional subspaces $H_L^N \subset H_L^2$ and $H^N \subset H^0$ satisfying certain approximation properties (as $N \rightarrow \infty$) to be specified below. The approximate system for $v^N \in H_L^N, w^N \in H^N$ is given by

$$\begin{aligned} (2.23) \quad & \langle \rho v_t^N + \mathcal{L}(v_t^N) + q_3 \mathcal{F}_1(t, \cdot, v^N) + q_3 f(x\dot{\theta} + v^N) + g(t, \cdot), \varphi^N \rangle \\ & + \langle q_1 w^N + q_2 D^2 v^N, D^2 \varphi^N \rangle = 0 \quad \text{for } \varphi^N \in H_L^N, \\ (2.24) \quad & \langle w_t^N - D^2 v^N, \psi^N \rangle = 0 \quad \text{for } \psi^N \in H^N, \\ (2.25) \quad & v^N(0) = P_L^N v(0), \quad w^N(0) = P^N w(0) \end{aligned}$$

where P_L^N, P^N are the orthogonal projections (in the H^0 norm) of H^0 onto H_L^N, H^N , respectively. We then may define a sequence of approximating parameter estimation problems consisting of minimizing over Q the criterion

$$(2.26) \quad J^N(q) = \sum_{i=1}^M |w^N(t_i, 0; q) - \varepsilon_i|^2$$

where w^N is the solution of (2.23) - (2.25) corresponding to q .

The procedure for arguing convergence of the approximate parameters \bar{q}^N (a minimizer of J^N in (2.26)) is now well-documented in a number of our previous papers (see [B] for a summary). A crucial step entails the following: If $\{q^N\}$ is an arbitrary sequence in Q with $q^N \rightarrow q$ in Q , one must establish the convergence $z^N \rightarrow 0$, $u^N \rightarrow 0$ where $z^N(t) = v^N - P_L^N v$, $u^N(t) = w^N - P_W^N w$ with v^N, w^N the solutions of (2.23)-(2.25) corresponding to q^N and v, w the solutions of (2.20) - (2.22) corresponding to q . We outline the arguments to establish this convergence.

Using (2.20) - (2.22) and (2.23) - (2.25) with $q = q^N$, we find for all $\varphi \in H_L^N$

$$\begin{aligned}
\langle \rho z_t^N, \varphi \rangle &= \langle v_t^N - v_t + (I - P_L^N)v_t, \varphi \rangle \\
&= \langle (I - P_L^N)v_t + \mathcal{L}(v_t) - \mathcal{L}(v_t^N), \varphi \rangle \\
&+ \langle q_3 \mathcal{F}_1(t, \cdot, v) - q_3^N \mathcal{F}_1(t, \cdot, v^N) + q_3 f(x\dot{\theta} + v) - q_3^N f(x\dot{\theta} + v^N), \varphi \rangle \\
&+ \langle q_1 w - q_1^N w^N + q_2 D^2 v - q_2^N D^2 v^N, D^2 \varphi \rangle \\
&= \langle (I - P_L^N)v_t + \mathcal{L}(-z_t^N) + \mathcal{L}((I - P_L^N)v_t), \varphi \rangle + (q_3 - q_3^N) \langle \mathcal{F}_1(t, \cdot, v), \varphi \rangle \\
&+ q_3^N \langle \mathcal{F}_1(t, \cdot, v) - \mathcal{F}_1(t, \cdot, v^N), \varphi \rangle + (q_3 - q_3^N) \langle f(x\dot{\theta} + v), \varphi \rangle \\
&+ q_3^N \langle f(x\dot{\theta} + v) - f(x\dot{\theta} + v^N), \varphi \rangle - \langle q_1^N (w^N - P_W^N w) + q_2^N D^2 (v^N - P_L^N v), D^2 \varphi \rangle \\
&+ \langle q_1 w - q_1^N P^N w + q_2 D^2 v - q_2^N D^2 P_L^N v, D^2 \varphi \rangle.
\end{aligned}$$

Thus we find (suppressing some of the obvious function arguments)

$$\begin{aligned}
\langle \rho z_t^N + \mathcal{L}(z_t^N), \varphi \rangle &= \langle (I - P_L^N)v_t + \mathcal{L}((I - P_L^N)v_t), \varphi \rangle \\
&+ (q_3 - q_3^N) \langle \mathcal{F}_1(v), \varphi \rangle + q_3^N \langle \mathcal{F}_1(v) - \mathcal{F}_1(P_L^N v), \varphi \rangle \\
(2.27) \quad &+ q_3^N \langle \mathcal{F}_1(P_L^N v) - \mathcal{F}_1(v^N), \varphi \rangle + (q_3 - q_3^N) \langle f(x\dot{\theta} + v), \varphi \rangle \\
&+ q_3^N \langle f(x\dot{\theta} + v) - f(x\dot{\theta} + P_L^N v), \varphi \rangle + q_3^N \langle f(x\dot{\theta} + P_L^N v) - f(x\dot{\theta} + v^N), \varphi \rangle \\
&- \langle q_1^N u^N + q_2^N D^2 z^N, D^2 \varphi \rangle + \langle q_1 w - q_1^N P^N w + q_2 D^2 v - q_2^N D^2 P_L^N v, D^2 \varphi \rangle
\end{aligned}$$

for all $\varphi \in H_L^N$. Also, for $\psi \in H^N$ we find

$$\begin{aligned}
\langle u_t^N, \psi \rangle &= \langle w_t^N - P^N w_t, \psi \rangle = \langle w_t^N - w_t + (I - P^N)w_t, \psi \rangle \\
(2.28) \quad &= \langle D^2 v^N - D^2 v, \psi \rangle + \langle (I - P^N)w_t, \psi \rangle \\
&= \langle D^2 z^N, \psi \rangle + \langle D^2 (P_L^N - I)v, \psi \rangle + \langle (I - P^N)w_t, \psi \rangle.
\end{aligned}$$

To obtain convergence estimates we make particular choices for φ and ψ in (2.27) and (2.28). Let $\varphi = z^N \in H_L^N$ in (2.27) and $\psi = u^N \in H^N$ in (2.28) and define $\theta_1^N \equiv D^2 (P_L^N - I)v$, $\theta_2^N \equiv (I - P^N)w_t$.

Then from (2.28) we obtain, using the inequality $ab \leq \frac{1}{4\epsilon} a^2 + \epsilon b^2$ where $\epsilon > 0$ can be arbitrarily

chosen,

$$\begin{aligned}
(2.29) \quad \frac{1}{2} \frac{d}{dt} |u^N|^2 &\leq \varepsilon |D^2 z^N|^2 + \frac{1}{4\varepsilon} |u^N|^2 + \varepsilon |\theta_1^N|^2 + \frac{1}{4\varepsilon} |u^N|^2 + \varepsilon |\theta_2^N|^2 + \frac{1}{4\varepsilon} |u^N|^2 \\
&= \varepsilon |D^2 z^N|^2 + \frac{3}{4\varepsilon} |u^N|^2 + \varepsilon |\theta_1^N|^2 + \varepsilon |\theta_2^N|^2.
\end{aligned}$$

Before deriving an analogous estimate from (2.27), we require some hypotheses on the nonlinear damping function f which will in turn yield estimates on \mathcal{L} and \mathcal{F}_1 . Recall that we can expect $f(v)$ to behave like $v|v| = (\text{sgn } v) v^2$ for v in some neighborhood (not necessarily small) of the origin, while it becomes bounded for v large. Thus, for our theoretical considerations here we make the reasonable assumptions that f satisfies a Lipschitz condition

$$(2.30) \quad |f(\xi_1) - f(\xi_2)| \leq K |\xi_1 - \xi_2| \quad \text{for } \xi_1, \xi_2 \text{ real}$$

as well as satisfying a boundedness condition

$$(2.31) \quad |f(\xi)| \leq M.$$

From (2.30) we readily obtain the estimates (we shall need these to use in estimates from (2.27) with $\varphi = z^N$)

$$\begin{aligned}
(2.32) \quad \langle f(x\dot{\theta} + v) - f(x\dot{\theta} + P_L^N v), z^N \rangle &\leq \int_0^\ell K |(I - P_L^N)v(t, x)| |z^N(t, x)| dx \\
&\leq K |(I - P_L^N)v(t)| |z^N(t)| \leq \frac{K}{2} |(I - P_L^N)v(t)|^2 + \frac{K}{2} |z^N(t)|^2,
\end{aligned}$$

where we have used $|\cdot|$ to denote either the absolute value or the $H^0(0, \ell)$ norm (the interpretation being clear from the usage). Similarly, we find

$$(2.33) \quad \langle f(x\dot{\theta} + P_L^N v) - f(x\dot{\theta} + v^N), z^N \rangle \leq K |v^N - P_L^N v| |z^N| = K |z^N(t)|^2.$$

Furthermore, using the definition (2.11) of \mathcal{F}_1 , we easily find

$$\begin{aligned}
(2.34) \quad \langle \mathcal{F}_1(t, \cdot, v) - \mathcal{F}_1(t, \cdot, P_L^N v), z^N \rangle &\leq \int_0^\ell \frac{dx \rho x}{I_B + k_2} \int_0^\ell K |(I - P_L^N)v(t, s)| s ds |z^N(t, x)| \\
&\leq \mu \left[|(I - P_L^N)v|^2 + |z^N(t)|^2 \right],
\end{aligned}$$

where the constant μ depends in an obvious way only on ℓ, K, ρ, I_B, k_2 . With similar calculations we find

$$(2.35) \quad \langle \mathcal{F}_1(t, \cdot, P_L^N v) - \mathcal{F}_1(t, \cdot, v^N), z^N \rangle \leq 2\mu |z^N(t)|^2.$$

Using the definition (2.10) of \mathcal{L} we next find

$$\begin{aligned}
(2.36) \quad \langle \mathcal{L}(z_t^N), z^N \rangle &= \int_0^\ell \left[\frac{-\rho x}{I_B + k_2} \int_0^\ell \rho s z_t(t,s) ds \right] z^N(t,x) dx \\
&= \frac{-\rho^2}{I_B + k_2} \frac{1}{2} \frac{d}{dt} \left[\int_0^\ell x z^N(t,x) dx \right]^2 \\
&= \frac{-\rho^2}{I_B + k_2} \frac{1}{2} \frac{d}{dt} \langle x, z^N(t) \rangle^2.
\end{aligned}$$

Also

$$\begin{aligned}
(2.37) \quad \langle \mathcal{L}((I - P_L^N)v_t), z^N \rangle &\leq \frac{\rho^2}{I_B + k_2} \frac{\ell^3}{3} |(I - P_L^N)v_t| |z^N| \\
&\leq \tilde{\mu} \left[|(I - P_L^N)v_t|^2 + |z^N(t)|^2 \right]
\end{aligned}$$

where the constant $\tilde{\mu}$ depends only on ρ, I_B, k_2, ℓ .

Finally, we can now obtain a desired estimate from (2.27) with $\varphi = z^N$. Using (2.32) - (2.37) we find

$$\begin{aligned}
(2.38) \quad &\frac{1}{2} \frac{d}{dt} \left[\rho |z^N|^2 - \frac{\rho^2}{I_B + k_2} \langle x, z^N \rangle^2 \right] \leq \frac{1}{2} |(I - P_L^N)v_t|^2 + \frac{1}{2} |z^N|^2 \\
&+ \tilde{\mu} \left[|(I - P_L^N)v_t|^2 + |z^N|^2 \right] + |q_3 - q_3^N| \tilde{M} |z^N| \\
&+ |q_3^N| \mu \left[|(I - P_L^N)v|^2 + |z^N|^2 \right] + |q_3^N| 2\mu |z^N|^2 + |q_3 - q_3^N| M\sqrt{\ell} |z^N| \\
&+ |q_3^N| \frac{K}{2} \left[|(I - P_L^N)v|^2 + |z^N|^2 \right] + |q_3^N| K |z^N|^2 \\
&+ |q_1^N| |u^N| |D^2 z^N| - \langle q_2^N D^2 z^N, D^2 z^N \rangle + |\theta_3^N| |D^2 z^N|
\end{aligned}$$

where $\theta_3^N \equiv \{q_1 w - q_1^N P^N w + q_2 D^2 v - q_2^N D^2 P_L^N v\}$.

Noting that $\langle x, z^N \rangle \leq \sqrt{\ell^3/3} |z^N|$, we find that

$$(2.39) \quad \frac{-\rho^2}{I_B + k_2} \langle x, z^N \rangle^2 \geq \frac{-\rho^2}{I_B + k_2} \frac{\ell^3}{3} |z^N|^2 = \frac{-\rho}{1 + 3k_2/\rho\ell} |z^N|^2$$

since $I_B = \int_0^\ell \rho x^2 dx = \rho \ell^3/3$. We assume that Q is a compact set and that the admissible parameter set Q entails the constraints $q_2 \geq v$ for some positive constant v . We then have

$$v |D^2 z^N|^2 \leq \langle q_2^N D^2 z^N, D^2 z^N \rangle.$$

Using these estimates in (2.38) we obtain

$$\begin{aligned} \frac{1}{2} \frac{d}{dt} \left[\rho |z^N|^2 - \frac{\rho^2}{I_B + k_2} \langle x, z^N \rangle^2 \right] &\leq \left(\frac{1}{2} + \tilde{\mu} \right) |(I - P_L^N) v_t|^2 \\ &+ \left[\frac{1}{2} + \tilde{\mu} + \frac{1}{2} + 3k\mu + \frac{1}{2} + k \frac{3K}{2} \right] |z^N|^2 \\ &+ \frac{1}{2} \left[\tilde{M}^2 + M^2 \ell \right] |q_3 - q_3^N|^2 + \frac{k^2}{4\epsilon} |u^N|^2 + \epsilon |D^2 z^N|^2 \\ &- v |D^2 z^N|^2 + \frac{1}{4\epsilon} |\theta_3^N|^2 + \epsilon |D^2 z^N|^2 \end{aligned}$$

or, assuming that $|q_3 - q_3^N| \rightarrow 0$,

$$(2.40) \quad \frac{1}{2} \frac{d}{dt} \left[\rho |z^N|^2 - \frac{\rho^2}{I_B + k_2} \langle x, z^N \rangle^2 \right] \leq \mathcal{X} |z^N|^2 + h^N(t) + (2\epsilon - v) |D^2 z^N|^2 + \frac{k^2}{4\epsilon} |u^N|^2$$

where $h^N(t)$ is bounded and $\rightarrow 0$ as $N \rightarrow \infty$ under the usual assumptions (see [B], [BCR],[BR1]) on the approximation properties of H_L^N and H^N (i.e. that $P_L^N \rightarrow I$, $P^N \rightarrow I$ in the desired topologies). For example, approximations based upon cubic splines in H_L^2 and linear splines in H^0 would suffice.

Finally combining (2.29) and (2.40) we obtain

$$(2.41) \quad \frac{1}{2} \frac{d}{dt} \left[\rho |z^N|^2 - \frac{\rho^2}{I_B + k_2} \langle x, z^N \rangle^2 + |u^N|^2 \right] \leq (3\epsilon - v) |D^2 z^N|^2 + \gamma_1 |z^N|^2 + \gamma_2 |u^N|^2 + G^N(t)$$

where G^N is bounded with $G^N(t) \rightarrow 0$. Integrating this inequality and using the fact that $z^N(0) = 0$, $u^N(0) = 0$, we find

$$(2.42) \quad \begin{aligned} \frac{1}{2} \left[\rho |z^N(t)|^2 - \frac{\rho^2}{I_B + k_2} \langle x, z^N(t) \rangle^2 + |u^N(t)|^2 \right] &+ (v - 3\epsilon) \int_0^t |D^2 z^N(s)|^2 ds \\ &\leq \int_0^t \left[\gamma_1 |z^N(s)|^2 + \gamma_2 |u^N(s)|^2 \right] ds + \int_0^t \left[|G^N(t)| + |h^N(t)| \right] dt. \end{aligned}$$

Finally, using (2.39) and choosing ϵ such that $v - 3\epsilon = \delta > 0$ in this last inequality, we obtain

$$\frac{1}{2} \left[\left[\rho - \frac{\rho}{1 + 3k_2/\rho \ell^3} \right] |z^N(t)|^2 + |u^N(t)|^2 \right]$$

(2.43)

$$+ \delta \int_0^t |D^2 z^N(s)|^2 ds \leq \Delta(N) + \int_0^t \left[\gamma_1 |z^N(s)|^2 + \gamma_2 |u^N(s)|^2 \right] ds$$

where $\Delta(N) \rightarrow 0$. Thus, by the usual Gronwall arguments we have $|z^N(t)|^2 \rightarrow 0$, $|u^N(t)|^2 \rightarrow 0$, and $\int_0^t |D^2 z^N(s)|^2 ds \rightarrow 0$, where $z^N(t) = v^N(t) - P_L^N v(t)$ and $u^N(t) = w^N(t) - P^N w(t)$. Under appropriate convergence properties for P_L^N and P^N , we may then use the triangle inequality to obtain

$$|v^N(t) - v(t)| \rightarrow 0, |w^N(t) - w(t)| \rightarrow 0, \int_0^t |D^2 v^N(s) - D^2 v(s)|^2 ds \rightarrow 0.$$

We note that the above arguments can be used to establish convergence at each t of the strain in the $H^0(0, \ell)$ norm. If we use the root strain $D^2 y(t, 0)$ in the least squares criterion, a stronger strain convergence (pointwise in the spatial coordinate) is needed to complete the theoretical development. Arguments in the spirit of those given above can be made to give strain convergence in the H^1 norm which, of course, yields root strain convergence. Arguments of this nature have been given for similar problems elsewhere [BCK], [BR2]; they involve some technical detail and we shall not pursue the development here. Instead we turn to a brief discussion of some computational aspects of these schemes.

The approximation and estimation schemes discussed above can be readily used to develop computational algorithms for estimation of damping coefficients (including those for the nonlinear viscous damping terms). We have developed and tested numerically some software packages based on these ideas. We are currently using the packages with experimental data provided by J. Juang; these results will be reported elsewhere. We close this section with a brief summary of findings for one of the numerical test examples we have investigated.

A test example was considered for the system (2.9) with $\ell = \rho = EI = 1.0$ assumed known and $c_4 = c_D = 0$. We sought to estimate the damping coefficient c_3 from simulated data for the strain. That is, we chose a particular function $y(t, x) = .5t^2(x^4 - 4x^3 + 6x^2)$ as the true solution of the system equation (2.9) with an appropriate forcing function added to the equation. The true parameter value $c_3^* = 2.0$ was used in (2.9) along with choices of $\theta(t)$ and $e_a(t)$ which were qualitatively similar to the corresponding experimental time histories available to us. For example, we used

$$\theta(t) = 4 \left[1 - \frac{1}{\beta} e^{-\zeta \omega_n t} \sin(\omega_n \beta t + \phi) \right] \quad \text{with} \quad \beta = \sqrt{1 - \zeta^2}, \quad \phi = \text{Arctan } \beta/\zeta$$

and ζ, ω_n chosen so that θ has a maximum amplitude of 4.5 at $t = 1.75$. The values $k_0 = 52.136, k_1$

$= 1672.96$ and $I_B + k_2 = 32.95$ were used in (2.9) along with $\dot{\theta}(t)$ obtained by differentiating θ .

For the approximating system we used modified cubic splines for both H_L^N and H^N ; the basis for H_L^N was the usual cubic B-spline basis modified to satisfy the boundary conditions of H_L^2 while the usual B-splines modified to satisfy the boundary conditions of H_R^2 were used to generate H^N . In each case the subspaces H_L^N , H^N had dimension $N + 1$. In the fit criterion we used the root strain $y_{xx}(t_i, 0)$ at 29 equally spaced observations in the time interval $0 \leq t \leq 7$. For the initial guess $c_3^0 = 2.5$, a residual of 1789 is obtained. For $N = 4$, the scheme produced a converged estimate $\bar{c}_3^N = 1.996$ with a corresponding residual of .0088. A number of other test examples were studied with equally satisfactory findings.

3. Hose Effects on the Dynamics of the RPL Structure

The RPL structure is an experimental apparatus which was designed and constructed at the Charles Stark Draper Laboratory in Cambridge, Massachusetts with funding supplied by the United States Air Force Rocket Propulsion Laboratory (RPL). Its primary function is to serve as a test bed for the purpose of investigating control algorithms and instrumentation (sensors, actuators, processors, etc.) for the large angle slewing of spacecraft with flexible appendages. It was designed to specifically incorporate those features which make control design for large flexible spacecraft an especially difficult and challenging problem. In particular, this includes light damping, high flexibility, a large number of, and closely spaced natural modes of vibration, difficult to model and coupled structural and actuator dynamics and dissipation mechanisms, etc.

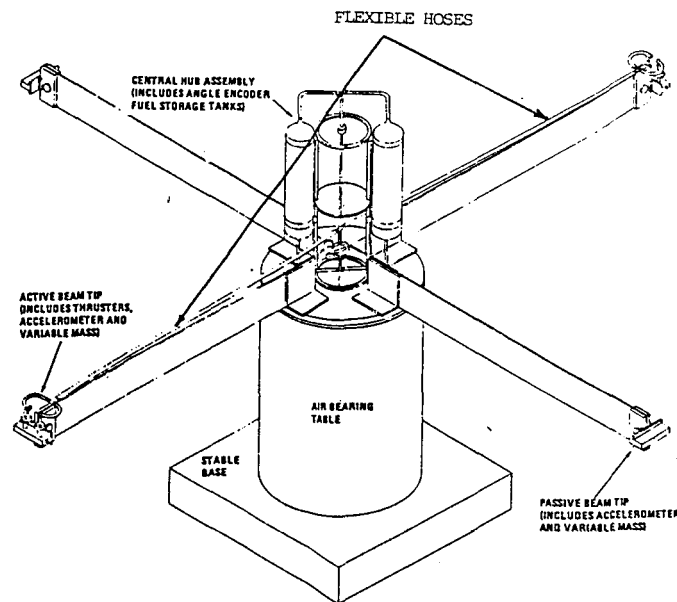

Figure 3.1

The structure itself consists of four aluminum beams, each of length $\ell = 4$ feet, width $b=6$ inches and thickness $h = .125$ inches, cantilevered in a symmetrical fashion to a central hub which is mounted on an air bearing table. The air bearing table allows for the near frictionless rotation of the entire structure about the vertical axis. Control actuation is achieved via nitrogen cold gas thrusters mounted at the tips of two opposing appendages. The other two beams are passive with masses at their tips serving only to maintain the over all symmetry of the structure. Nitrogen gas is supplied to the thrusters from storage tanks mounted to the central hub through stainless steel, wire mesh wrapped, flexible, high pressure hoses. Electro-mechanical valves control the expulsion of the gas from the thruster nozzles. Each appendage is instrumented with a linear accelerometer at the tip. Data from the sensors is recorded and control input signals are generated using a MINC 11/23 microcomputer.

Effective control design depends heavily upon the availability of a high fidelity model for the plant. In the case of the RPL structure, it is immediately clear that a model involving partial differential equations would be of some use. For the transverse vibration of the passive beams, a distributed parameter model based upon the Euler-Bernoulli equation together with appropriate boundary conditions describing the coupled motion of the tip mass and the rigid body rotation of the central hub would be adequate. For the active appendages (i.e., those with the tip thrusters) on the other hand, a more sophisticated model which also captures the coupled dynamic effects (i.e. additional mass, stiffness and dissipation, torsional motion, etc.) due to the motion of the flexible thruster hoses is needed.

Since the transverse vibration of each of the individual appendages is decoupled, for our investigation here, we consider the problem of modeling the hose effects on the transverse vibration of a single cantilevered (i.e. clamped - free) beam (see Figure 3.2).

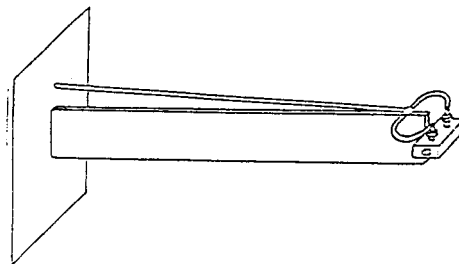

Figure 3.2

We describe a model which was suggested by S. Gates of the Control and Flight Dynamics division of the Draper Laboratory wherein the hose is treated as a damped linear harmonic oscillator that is rigidly attached to the thruster assembly at the free end of the beam. More precisely, the hose is modeled as a proof mass which reacts against the tip or thruster mass via an elastic spring and a linear, viscous damper (see Figure 3.3)

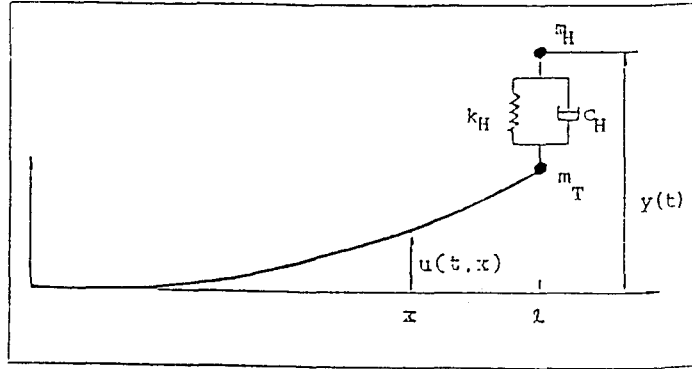

Figure 3.3

Letting $u(t, x)$ denote the vertical displacement of the beam at time t and position x , $0 \leq x \leq l$, and assuming only small deformations (i.e. $|u(t, x)| \ll l$, $|\frac{\partial u}{\partial x}(t, x)| \ll 1$)

we use the Euler-Bernoulli equation together with Kelvin-Voigt viscoelastic material damping to describe its transverse vibration. That is

$$(3.1) \quad \rho \frac{\partial^2 u}{\partial t^2}(t, x) + c_D I \frac{\partial^4}{\partial x^4} \frac{\partial u}{\partial t}(t, x) + EI \frac{\partial^4 u}{\partial x^4}(t, x) = 0 \quad 0 < x < l, \quad t > 0$$

where ρ is the linear mass density, c_D and E are respectively the material coefficient of viscosity and modulus of elasticity and $I = bh^3/12$ is the second moment or moment of inertia of the uniform, rectangular cross section of the beam.

At the free end of the beam, corresponding to $x = l$, the motion of the tip mass m_T and the hose mass m_H are given by

$$(3.2) \quad m_T \frac{\partial^2 u}{\partial t^2}(t, l) - c_D I \frac{\partial^3}{\partial x^3} \frac{\partial u}{\partial t}(t, l) - EI \frac{\partial^3 u}{\partial x^3}(t, l) \\ = c_H \left(\frac{dy}{dt}(t) - \frac{\partial u}{\partial t}(t, l) \right) + k_H (y(t) - u(t, l)) + f(t), \quad t > 0$$

and

$$(3.3) \quad m_H \frac{d^2 y}{dt^2}(t) + c_H \left(\frac{dy}{dt}(t) - \frac{\partial u}{\partial t}(t, l) \right) + k_H (y(t) - u(t, l)) = 0, \quad t > 0$$

respectively where $y(t)$ is the vertical displacement of the hose mass at time t measured from the equilibrium position, $f(t)$ is the thruster force at time t and c_H and k_H are respectively the hose damping and stiffness coefficients. Assuming that the rotational inertia due to the hose - thruster

assembly is negligible, we also have the zero moment condition

$$(3.4) \quad c_D I \frac{\partial^2}{\partial x^2} \frac{\partial u}{\partial t}(t, \ell) + EI \frac{\partial^2 u}{\partial x^2}(t, \ell) = 0, \quad t > 0$$

at the free end. At the clamped end, we have the usual geometric boundary conditions of zero displacement,

$$(3.5) \quad u(t, 0) = 0, \quad t > 0$$

and zero slope,

$$(3.6) \quad \frac{\partial u}{\partial x}(t, 0) = 0, \quad t > 0.$$

Assuming that the system is initially at rest, we have the temporal boundary conditions or initial conditions given by

$$(3.7) \quad u(0, x) = 0, \quad \frac{\partial u}{\partial t}(0, x) = 0, \quad 0 \leq x \leq \ell$$

and

$$(3.8) \quad y(0) = 0, \quad \frac{dy}{dt}(0) = 0.$$

Our primary concern here is the inverse problem which is naturally associated with the mathematical model given by equations (3.1) - (3.8) above. The physical dimensions and mass properties of the beam and thruster assembly and the elastic properties of the material from which the beam is made are known. Also, the thruster output can be experimentally calibrated. Consequently the parameters ℓ , ρ , E , m_T and b and h (and therefore I) are known. The input function f is given as well. However, the coefficient of viscosity c_D and the hose parameters m_H , c_H and k_H must be determined via an identification procedure. Recalling that the structure is instrumented with a linear accelerometer at the tip of the beam, we formulate the following inverse or parameter identification problem.

Given a known input $f(t)$ and corresponding measured output $z(t)$ for $t \in [t_0, t_1]$, determine the parameters $\bar{q} = (\bar{c}_D, \bar{m}_H, \bar{c}_H, \bar{k}_H)^T$ in a closed and bounded subset Q of R^4 , which minimize the least squares performance index

$$(3.9) \quad J(q) = \int_0^{t_1} \left| \frac{\partial^2 u}{\partial t^2}(t, \ell; q) - z(t) \right|^2 dt$$

where $u(\cdot, \cdot; q)$ denotes the solution to the initial boundary value problem (3.1) - (3.8) corresponding to the choice of parameters $q = (c_D, m_H, c_H, k_H) \in Q$.

Implicit in the statement of the problem above is the well posedness of the initial boundary value problem, i.e. the existence, uniqueness and regularity of solutions to the system (3.1) - (3.8). The infinite dimensionality of the distributed state constraints necessitates the development and use of some form of finite dimensional approximation. Both of these issues are most efficiently addressed via an abstract, functional analytic formulation of the system (3.1) - (3.8).

Define the Hilbert space $H = \mathbb{R}^2 \times L_2(0, \ell)$ endowed with the usual inner product and let $V = \{(\zeta, \eta, \varphi) \in H: \varphi \in H^2(0, \ell), \varphi(0) = D\varphi(0) = 0, \eta = \varphi(\ell)\}$. Define the coercive bilinear forms c and k from $V \times V$ into \mathbb{R} by $c(\hat{\varphi}, \hat{\psi}) = c_H(\zeta - \varphi(\ell))(\lambda - \psi(\ell)) + c_D I \langle D^2\varphi, D^2\psi \rangle$ and $k(\hat{\varphi}, \hat{\psi}) = k_H(\zeta - \varphi(\ell))(\lambda - \psi(\ell)) + EI \langle D^2\varphi, D^2\psi \rangle$ for $\hat{\varphi} = (\zeta, \varphi(\ell), \varphi) \in V$ and $\hat{\psi} = (\lambda, \psi(\ell), \psi) \in V$, the operator $M \in \mathcal{L}(H, H)$ by $M(\zeta, \eta, \varphi) = (m_H \zeta, m_T \eta, \rho \varphi)$ and set $F(t) = (0, f(t), 0) \in H$. Then the initial boundary value problem (3.1) - (3.8) can be rewritten in weak form as

$$(3.10) \quad \langle M \hat{u}_t(t), \hat{\varphi} \rangle_H + c(\hat{u}_t(t), \hat{\varphi}) + k(\hat{u}(t), \hat{\varphi}) = \langle F(t), \hat{\varphi} \rangle_H, \quad t > 0, \hat{\varphi} \in V$$

$$(3.11) \quad \hat{u}(0) = 0, \quad \hat{u}_t(0) = 0,$$

for $\hat{u}(t) = (y(t), u(t, \ell), u(t, \cdot)) \in V$.

Depending upon the degree of smoothness imposed upon the input f as a function of t (i.e. L_2 , Hölder continuity, H^1 , etc.), standard results from the theory of abstract parabolic equations (see [F], [S]) can be used to demonstrate the existence and uniqueness of solutions to (3.10) - (3.11) with varying degrees of regularity.

We define finite dimensional approximations to the system (3.10), (3.11) using a cubic spline based Galerkin scheme. For each $N = 1, 2, \dots$, let $\{\beta_j^N\}_{j=1}^{N+1}$ denote the usual cubic polynomial B-splines defined on the interval $[0, \ell]$ with respect to the uniform mesh $\{0, \ell/N, 2\ell/N, \dots, \ell\}$ and which have been modified to satisfy $\beta_j^N(0) = D\beta_j^N(0) = 0, j=1, 2, \dots, N+1$. Set $\beta_0^N = (1, 0, 0)$, $\beta_j^N = (0, \beta_j(\ell), \beta_j)$, $j = 1, 2, \dots, N+1$ and $V^N = \text{span} \{\hat{\beta}_j^N\}_{j=0}^{N+1}$. The Galerkin equations corresponding to (3.10), (3.11) for $\hat{u}^N(t) \in V^N$ are given by

$$(3.12) \quad \langle M \hat{u}_t^N(t), \hat{\beta}_j^N \rangle_H + c(\hat{u}_t^N(t), \hat{\beta}_j^N) + k(\hat{u}^N(t), \hat{\beta}_j^N) = \langle F(t), \hat{\beta}_j^N \rangle_H, \quad t > 0, j = 0, 1, 2, \dots, N+1$$

$$(3.13) \quad \hat{u}^N(0) = 0 \quad \hat{u}_t^N(0) = 0.$$

For $q = (c_D, m_H, c_H, k_H) \in Q$, let $\hat{u}^N(t; q) = (y^N(t; q), u^N(t, \ell; q), u^N(t, \cdot; q))$ denote the solution to the finite dimensional system (3.12), (3.13) corresponding to the choice of parameters $q \in Q$ and let

$\hat{u}(t; q)$ be defined analogously with respect to the system (3.10), (3.11). If $\frac{\partial^2 u}{\partial t^2}(t, \ell; q)$ in the least

squares performance index J given by (3.9) is replaced with $\frac{\partial^2 u^N}{\partial t^2}(t, \ell; q)$ and the resulting finite

dimensionally constrained estimation problem (henceforth referred to as the N^{th} approximating estimation problem) is solved, an approximation to the optimal parameters \bar{q} is obtained. Indeed, it can be argued (using estimates in the spirit of those given in the previous section; see [BGRW] for the details) that if f is smooth and if $\{q^N\}_{N=1}^{\infty}$ is a sequence in Q with $q^N \rightarrow q^0$,

then $\hat{u}_u^N(\cdot; q^N) \rightarrow \hat{u}_u(\cdot; q^0)$ in $L_2(0, T; H)$ (or equivalently, that $\frac{\partial^2 u^N}{\partial t^2}(\cdot, \ell; q^N) \rightarrow \frac{\partial^2 u}{\partial t^2}(\cdot, \ell; q^0)$

in $L^2(0, T)$ as $N \rightarrow \infty$. This in turn can then be used to show that if \bar{q}^N is a solution (which can be shown to exist) to the N^{th} approximating estimation problem, the sequence $\{\bar{q}^N\}_{N=1}^{\infty} \subset Q$ admits a convergent subsequence $\{\bar{q}^{N_j}\}_{j=1}^{\infty}$ with $\bar{q}^{N_j} \rightarrow \bar{q}$ as $j \rightarrow \infty$ and \bar{q} is a solution to the original infinite dimensionally constrained identification problem.

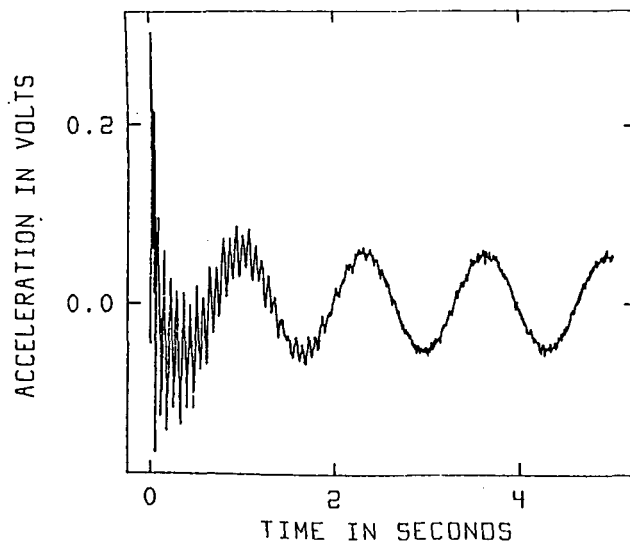

Figure 3.4

We tested our model and scheme using data produced by the following experiment carried out for us on the RPL structure by Dr. Michel A. Floyd, formerly of the Draper Laboratory. With the central hub held stationary and the structure initially at rest, a thruster line was pressurized to 300 psi and the corresponding jet fired for 50 milliseconds. Linear acceleration at the tip of the corresponding appendage was recorded over the period 0 to 5 seconds with a sampling interval of 5 milliseconds yielding 1000 measurements. With the accelerometer calibrated to 5 volts/g ($g = 32 \text{ ft/sec}^2$), the observations produced are plotted in Figure 3.4 above.

From an FFT of the data we found the first three frequencies to be approximately .75 Hz, 7.5Hz and 14Hz. A visual inspection of the data immediately reveals the modes at .75Hz and 14Hz. The mode at 14Hz is a torsional mode, or, more precisely, a twisting of the beam about its longitudinal axis. The excitation of this mode results from a combination of factors including the presence of the hose and the fact that it is connected to the thruster assembly at the top rather than the center of the beam and the opening and closing of the thruster valves. Since the torsional vibration is at a much higher frequency than are either of the first two transverse vibrational modes, and since it is relatively rapidly damped, in our study here we simply treated it as noise and left it unmodeled. A more detailed discussion of the torsional effects and its coupling into the accelerometer measurements of the transverse motion of the beam can be found in [BGRW].

The beam is made of a grade of aluminum having linear mass density $\rho = .027 \text{ slug/ft}$ and modulus of elasticity $E = 15.84 \times 10^8 \text{ lb/(ft)}^2$. We have $\ell = 4\text{ft}$ and $I = bh^3/12 = 4.71 \times 10^{-8}(\text{ft})^4$. The mass of the thruster assembly m_T was determined to be .149 slug. A hose pressure of 300 psi was determined to be equivalent to a force of .297lb. We have therefore

$$f(t) = \begin{cases} 0.297\text{lb} & 0 \leq t \leq .05 \\ 0.0 & .05 < t \leq 5.0. \end{cases}$$

The index of approximation N was taken to be 4 throughout. A detailed study of the convergence properties of our scheme using test examples and simulation data was carried out with the results having been reported in [BGRW].

We neglected the hose effects and internal damping (i.e., we took $c_D = m_H = c_H = k_H = 0$) and used the standard Euler-Bernoulli model for a cantilevered beam with tip mass to generate values for the linear acceleration at the tip. The resulting acceleration profile along with the experimentally observed data is plotted in Figure 3.5. If one is willing to accept the Euler-Bernoulli theory as a reasonable description for the transverse vibration of a long, slender, flexible beam, then it is clear from the figure that the hose effects are indeed significant and should be modeled. The residual was found to be 3.03.

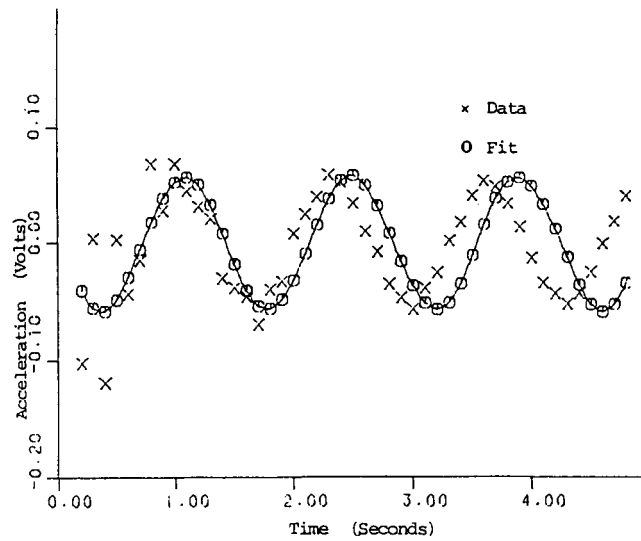

Figure 3.5

In applying our scheme we used the data over the interval 3.0 to 5.0 seconds (where the contribution from the torsional mode has been significantly damped) sampled at the rate of 10 observations per second. By matching the first two modal frequencies of the data with the first two modal frequencies of the model we obtained crude estimates for m_H and k_H that could be used as start-up values for an iterative optimization procedure. Then, using our spline-based scheme along with an iterative Levenberg-Marquardt nonlinear least-squares routine to solve the approximating estimation problems to search over m_H and k_H , optimal values for the hose mass and hose stiffness were obtained. Taking these values along with $c_H = 0$ as start-up values, we used our scheme again to obtain optimal values for m_H , c_H and k_H . Repeating this general procedure, we obtained the optimal values for the parameters c_D , m_H , c_H and k_H given in Table 3.1. The corresponding tip acceleration profile is plotted in Figure 3.6. The residual was computed to be .70 - a clear improvement.

c_D (lb sec/ft ²)	m_H (slug)	c_H (lb.sec/ft)	k_H (lb/ft)
127.40	.0801	.0078	.413

Table 3.1

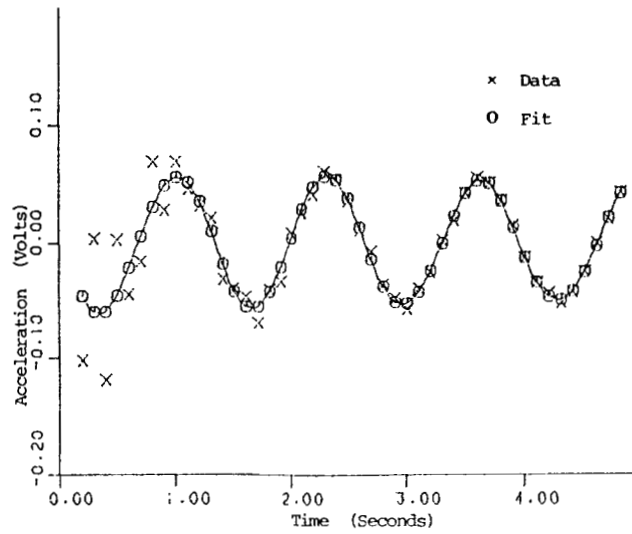

Figure 3.6

In summary, our results demonstrate the feasibility and effectiveness of using distributed parameter systems to model structural dynamics. Our finite dimensional approximation methods provide a viable means for estimating unknown parameters appearing in the models which can not be explicitly measured experimentally. Finally, our general approach appears to compare favorably (see [BGRW]) with other identification procedures for the estimation of parameters in models for structural dynamics which are commonly used in engineering practice.

Acknowledgment. The authors would like to gratefully acknowledge Ms. Y. Wang of the Division of Applied Mathematics at Brown University for her assistance in carrying out the computations reported on in this note. In addition, they would also like to express their sincere appreciation to Dr. Jer-Nan Juang of the Structural Dynamics Branch of the NASA Langley Research Center for the numerous stimulating conversations and collaboration which motivated their efforts on the estimation of nonlinear damping in slewing beam maneuvers discussed in the first part of this paper.

References

- [B] H.T. Banks, On a variational approach to some parameter estimation problems, *Distributed Parameter Systems*, Proceedings of the 2nd International Conference, Vorau, Austria, 1984, Volume 75 in Lecture Notes in Control and Information Sciences, Springer-Verlag, Berlin, 1985, 1 - 23.
- [BC1] H.T. Banks and J.M. Crowley, Estimation of material parameters in elastic systems, LCDS Rep No 84 - 20, Brown Univ., June 1984.
- [BC2] H.T. Banks and J.M. Crowley, Parameter identification in continuum models, *J. Astronautical Sci.* 33 (1985), 85 - 94.
- [BCK] H.T. Banks, J.M. Crowley and K.Kunisch, Cubic spline approximation techniques for parameter estimation in distributed systems, *IEEE Trans. Automatic Control* AC-28 (1983), 773-786.
- [BCR] H.T. Banks, J.M. Crowley, and I.G. Rosen, Methods for the identification of material parameters in distributed models for flexible structures, ICASE Rep No. 84-66, NASA Langley Research Center, Hampton, VA; *Mat. Applicada e Comput.* 5 (1986), to appear.
- [BGRW] H.T. Banks, S.S. Gates, I.G. Rosen and Y. Wang, The identification of a distributed parameter model for a flexible structure, ICASE Rep. No 86-72, NASA Langley Research Center, Hampton, VA; *SIAM J. Control and Opt.*, submitted.
- [BR1] H.T. Banks and I.G. Rosen, Computational methods for the identification of spatially varying stiffness and damping in beams, ICASE Rep No. 86-70, NASA Langley Research Center, Hampton, VA; *Control-Theory and Advanced Technology*, to appear.
- [BR2] H.T. Banks and I.G. Rosen, Numerical schemes for the estimation of functional parameters in distributed models for mixing mechanisms in lake and sea sediment cores, LCDS Rep No. 85-27, Brown University; *Inverse Problems*, to appear.
- [F] A. Friedman, *Partial Differential Equations of Parabolic Type*, Prentice Hall, Englewood Cliffs, New Jersey, 1964.
- [HJ] L.G. Horta and J.N. Juang, Identifying approximate linear models for simple nonlinear systems, *J. Guidance, Control and Dynamics*, to appear.

- [JH] J.N. Juang and L.G. Horta, Effects of atmosphere on slewing control of a flexible structure, 27th Structures, Structural Dynamics, and Materials Conference, Paper No. 86-1001- CP, May, 1986, San Antonio.
- [JHR] J.N. Juang, L.G. Horta, and H.H. Robertshaw, A slewing control experiment for flexible structures, *J. Guidance, Control and Dynamics*, to appear.
- [S] R.E. Showalter, *Hilbert Space Methods for Partial Differential Equations*, Pitman, London, 1977.

Standard Bibliographic Page

1. Report No. NASA CR-178259 ICASE Report No. 87-10		2. Government Accession No.		3. Recipient's Catalog No.	
4. Title and Subtitle INVERSE PROBLEMS IN THE MODELING OF VIBRATIONS OF FLEXIBLE BEAMS				5. Report Date February 1987	
				6. Performing Organization Code	
7. Author(s) H. T. Banks, R. K. Powers, and I. G. Rosen				8. Performing Organization Report No. 87-10	
9. Performing Organization Name and Address Institute for Computer Applications in Science and Engineering Mail Stop 132C, NASA Langley Research Center Hampton, VA 23665-5225				10. Work Unit No.	
				11. Contract or Grant No. NAS1-17070, NAS1-18107	
12. Sponsoring Agency Name and Address National Aeronautics and Space Administration Washington, D.C. 20546				13. Type of Report and Period Covered Contractor Report	
				14. Sponsoring Agency Code 505-90-21-01	
15. Supplementary Notes Langley Technical Monitor: J. C. South Final Report Submitted to Proceedings of the Conference on Control Theory for Distributed Parameter Systems and Applications, Vorau, Austria					
16. Abstract The formulation and solution of inverse problems for the estimation of parameters which describe damping and other dynamic properties in distributed models for the vibration of flexible structures is considered. Motivated by a slewing beam experiment, the identification of a nonlinear velocity dependent term which models air drag damping in the Euler-Bernoulli equation is investigated. Galerkin techniques are used to generate finite dimensional approximations. Convergence estimates and numerical results are given. The modeling of, and related inverse problems for the dynamics of a high pressure hose line feeding a gas thruster actuator at the tip of a cantilevered beam are then considered. Approximation and convergence are discussed and numerical results involving experimental data are presented.					
17. Key Words (Suggested by Authors(s)) inverse problems, approximation, elastic structures			18. Distribution Statement 64 - Numerical Analysis 66 - Systems Analysis Unclassified - unlimited		
19. Security Classif.(of this report) Unclassified		20. Security Classif.(of this page) Unclassified		21. No. of Pages 23	22. Price A02