

NASA  
Technical Memorandum 89912

AVSCOM  
Technical Report 87-C-10

# Helicopter Transmission Testing at NASA Lewis Research Center

David G. Lewicki and John J. Coy  
*Propulsion Directorate*  
*U.S. Army Aviation Research and Technology Activity—AVSCOM*  
*Lewis Research Center*  
*Cleveland, Ohio*

(NASA-TM-89912) HELICOPTER TRANSMISSION  
TESTING AT NASA LEWIS RESEARCH CENTER  
(NASA) 18 P Avail: NTIS EC A02/MF A01

N87-22978

CSCD 131

MS

1/37

Unclas  
0074222

Prepared for the  
Testing of Aerospace Transmissions Conference  
sponsored by the Institute of Mechanical Engineers  
Derby, England, June 10, 1987

**NASA**



# HELICOPTER TRANSMISSION TESTING AT NASA LEWIS RESEARCH CENTER

David G. Lewicki and John J. Coy  
Propulsion Directorate  
U.S. Army Aviation Research and Technology Activity - AVSCOM  
Lewis Research Center  
Cleveland, Ohio 44135

## SUMMARY

The helicopter has evolved into a highly valuable air mobile vehicle for both military and civilian needs. The helicopter transmission, just as well as engines and rotors, requires advanced studies to develop a technology base for future rotorcraft advances. A joint helicopter transmission research program between the NASA Lewis Research Center and the U.S. Army Aviation Systems Command has existed since 1970. Program goals are to reduce weight and noise and to increase life and reliability. The current experimental activities at Lewis consist of full-scale helicopter transmission testing, a base effort in gearing technology, and a future effort in noise reduction technology. This paper reviews the experimental facilities at Lewis for helicopter transmission testing. A description of each of the rigs is presented along with some significant results and near-term plans.

## INTRODUCTION

NASA Lewis has had a strong research program for aircraft mechanical components since the early 1940's. The helicopter came into wide use as a military and commercial air mobile vehicle during the late 1940's to the late 1960's. By then the U.S. Army had a wide spectrum of helicopters in its inventory along with the requirement to increase their performance. Also, NASA Lewis had established a capability in mechanical component research that could be applied to helicopter transmissions.

A joint transmission research program was started in 1970 with NASA Lewis and the Army, and continues to the present (refs. 1 to 6). The major goals of the program were to increase the life, reliability, and maintainability, reduce the weight, noise, and vibration, and maintain the relatively high mechanical efficiency of the gear train in helicopter transmissions. The approach was to identify advanced materials and lubrication schemes, as well as advanced design concepts for both transmission components and total transmission systems. Also, in-house and university grant efforts developed analytical codes for analysis and design. Unique experimental testing facilities were established at NASA Lewis for testing mechanical components, materials, and lubrication techniques, as well as demonstrating advanced design concepts and verifying analytical codes.

The purpose of this paper is to review the current experimental activity at NASA Lewis on helicopter transmission testing. A description of the rigs is given along with some significant results. The present major efforts at NASA Lewis consist of full-scale helicopter transmission testing, a base effort in gearing technology, and a future effort in noise reduction technology.

## NASA LEWIS TEST STANDS

The helicopter transmission program at NASA Lewis aims at conducting research on drive trains and supporting technologies for present and advanced concept rotorcraft. Research program goals are to decrease weight and increase strength, increase life, and reduce noise. The programs are performed in-house and on contracts and grants. Analytical efforts include the development of computer aided codes. The codes are used in design, performance analysis, and optimization of transmission components and total systems. As an important part of the research program, experimental efforts are required for verification of analytical predictions. Experimental research also provides a demonstration of advanced technology concepts and materials.

NASA Lewis currently has six active experimental test stands associated with helicopter transmission testing. They are the 500-hp helicopter transmission test stand, the 3000-hp helicopter transmission test stand, the planetary gear test stand, the spur gear fatigue test apparatus, the bevel gear apparatus, and the high speed gear test stand. NASA Lewis is also developing a gear noise test stand due to a current emphasis on transmission noise reduction. The rigs provide analytical code verification and a baseline from which to assess the promised advantages of future design and concepts.

### 500-hp Helicopter Transmission Test Stand

NASA Lewis has two full-scale helicopter transmission test stands. The first, the 500-hp helicopter transmission test stand (fig. 1), was designed at the start of October 1977 and became operational in October 1979. The test stand operates on a "four square" or torque-regenerative principle. Mechanical power is recirculated through a closed loop of gears and shafting, one of which is the test transmission. A 149-kW (200-hp) variable speed motor powers the test stand and controls the speed. Only losses due to friction are replenished by the motor since power is recirculated around the loop. An 11-kW (15-hp) motor provides the torque in the closed loop. This motor drives a magnetic particle clutch; the clutch output exerts a torque through a speed reducer gearbox and chain drive to a large sprocket on the differential gearbox. The magnitude of torque in the loop is adjusted by changing the electric field strength of the magnetic particle clutch. The facility is equipped with torque, speed, temperature, oil flow, and oil pressure sensors to monitor operating conditions and health states.

The baseline testing was performed on the Bell 236-kW (317-hp) OH-58A helicopter main rotor transmission (fig. 2). The OH-58A is a single-engine, land-based, light observation helicopter, serving both military (OH-58A Kiowa) and commercial (Bell Model 206 Jet Ranger) needs. The main rotor transmission is a two-stage reduction gearbox with a single spiral bevel mesh as the first stage and a three-planet, fixed-ring gear planetary mesh as the second. The overall reduction ratio of the transmission is 17.44:1. The transmission input is rated for use for an engine output of 210 kW (270 hp) continuous power at 6180 rpm and 236 kW (317 hp) for 5 min at takeoff. Data were collected for bevel pinion gear tooth strain measurements, bevel gear deflections, component temperatures (bearings, gears, seals, oil), vibrations, and transmission mechanical efficiencies. The testing consisted of a matrix of speed and load conditions.

For efficiency tests the test transmission and an oil-to-water heat exchanger were thermally insulated to provide an adiabatic enclosure. A heat balance was then performed on the water which cooled the transmission oil. The mechanical efficiency was determined by measuring the heat generation due to mechanical losses. Overall transmission efficiency for the OH-58A varied from about 98.3 to 98.8 percent at full speed and load conditions and was a function of lubricant and lubricant temperature (fig. 3, ref. 7). A reasonable correlation of efficiency with lubricant viscosity was made when the viscosities were corrected for temperature and pressure effects in the lubricated contact (ref. 8).

Vibration signals from accelerometers mounted at various locations on the OH-58A transmission housing were analyzed by using Fourier spectra, power spectral density functions, and averaging techniques (ref. 9). The Fourier spectra showed vibration amplitude peaks occurring at the spiral bevel gear mesh harmonics and planetary gear mesh harmonics (fig. 4). The highest magnitude of vibration was at the spiral bevel gear meshing frequency. In addition, the highest measured overall broadband acceleration was about 10 g's rms (occurring at full speed and load and measured on the housing near the ring gear). The measurement location and transmission speed had a significant effect on measured vibration. Current work is being performed in analyzing the remaining OH-58A transmission data. Also, a four-planet OH-58A transmission was tested and the results are being compared to the baseline three-planet.

At present the rig is used to evaluate two advanced design concept transmissions in the 223 to 373 kW (300 to 500 hp) range. The first is the NASA/Bell Helicopter Textron (BHT) 500-hp advanced technology transmission (fig. 5). The design goal was to upgrade the OH-58C 236-kW (317-hp) version to 372 kW (500 hp) while retaining long life with a minimum increase in cost, weight, and size. This was accomplished by implementing advanced technology developed during the last decade and improvements dictated by field experience (ref. 10). The major changes were to incorporate: high contact ratio planetary gears, improved bearing and gear materials, an improved planet carrier design, a cantilever-mounted planetary ring gear, an improved sun gear spline design, and a straddle mounted bevel gear. The final design had a weight to power ratio of 1.55 N/kW (0.26 lb/hp) compared to 2.21 N/kW (0.37 lb/hp) for the OH-58C transmission.

The 500-hp advanced technology transmission was recently tested at NASA Lewis. Similar data as that for the OH-58A were collected (strains, deflections, temperatures, vibrations, and efficiencies) and the results are being analyzed. Preliminary results show the mechanical efficiency measured 98.5 percent at 82 °C (180 °F) oil inlet temperature and 98.6 percent at 99 °C (210 °F), comparable to the OH-58A.

The second advanced design concept transmission in the 223 to 373 kW (300 to 500 hp) class is the self-aligning bearingless planetary (SABP) transmission (fig. 6). In this transmission conventional planet gears are replaced by planet spindles. The spindles each have three gears on them; one gear meshes with a sun gear, one with a fixed ring gear, and one with a rotating output ring gear. The gears on the spindle are spaced such that tangential gear forces are balanced and the spindles are in equilibrium. Tooth separating and centrifugal forces are reacted by cylindrical rings concentric with the sun

gear axis. Thus, the planet bearings and planet carrier are eliminated, reducing the transmission weight. Planet bearing failures and power losses commonly associated with conventional planetary transmissions are eliminated. Also, transmission vulnerability due to loss of lubrication is decreased. The design study projected a weight savings of 17 to 30 percent and a reliability improvement factor of 2:1 over standard transmissions (ref. 11). A 336-kW (450-hp) SABP transmission retrofitting the OH-58A was fabricated and is currently being tested at NASA Lewis.

Future plans of the 500-hp transmission test stand include full-scale testing of advanced lubricants under the U.S. Navy Helicopter Lubrication Program. Presently, a common engine and transmission oil is used in military helicopters. The oil conforms to either a MIL-L-23699 or a MIL-L-7808 specification, and provides satisfactory lubrication for turbine engines but marginal performance for transmissions. Helicopter transmission overhauls show an increasing rate of bearing and gear rejections due to surface distress, corrosion, and wear. Due to this the Navy has initiated the U.S. Navy Helicopter Lubrication Program to develop a separate transmission lubricant with improved load-carrying capacity and corrosion inhibition (ref. 12). The 500-hp transmission test stand at NASA Lewis will be used for the full-scale gearbox testing of the advanced lubricants. The 500-hp rig will be modified to include lift and bending loads on the transmission output shaft to closer model transmission loading seen in the field.

#### 3000-hp Helicopter Transmission Test Stand

The second full-scale helicopter transmission test stand at NASA Lewis is the 3000-hp rig (fig. 7). The 3000-hp test stand was designed and built by the Boeing Vertol Company, refurbished by NASA, and put on line at NASA Lewis in March 1981. The test stand operates on a torque-regenerative principle. Power to the test transmission flows through two inputs (simulating two engines) and two outputs (main rotor and tail drive). Power is provided by a constant speed 600-kW (800-hp) induction motor and speed is controlled by an eddy current clutch. Torque is induced independently in each loop by planetary torque units. The stand is also capable of applying lift loads, moment loads, and drag loads on the transmission output shaft.

The test stand was designed for testing the U.S. Army's 3000-hp Utility Tactical Transport Aircraft System (UTTAS) helicopter main rotor transmission. During the UTTAS development, two prototype versions were considered by the Army. One was the YUH-61A helicopter, designed and manufactured by the Boeing Vertol Company. The other was the UH-60A helicopter by Sikorsky Aircraft. The Army eventually chose the UH-60A (Black Hawk) for production. Both the YUH-61A and the UH-60A transmissions were tested at NASA Lewis.

The YUH-61A helicopter transmission has a rated power level of 2080 kW (2792 hp) at an output rotor shaft speed of 286 rpm. The transmission has two twin inputs. Input spiral bevel gears mesh with a combining spiral bevel gear for the first reduction stage. The second reduction stage consists of a four-planet, fixed-ring gear planetary. The overall transmission reduction ratio is 25.096:1. Efficiency and vibration data were taken in the 3000-hp stand (ref. 13). The mechanical efficiency measured 98.7 percent at full power.

The 3000-hp stand was modified to test the UH-60A (Black Hawk) helicopter transmission. The transmission is rated at 2110 kW (2828 hp) at an output speed of 258 rpm. The transmission overall reduction ratio is 81.042:1. Note that the UH-60A transmission has one more spiral bevel reduction stage in comparison to the YUH-61A transmission. The UH-60A transmission is designed to accept input directly from the engines where the YUH-61A has a pair of external gearboxes between the engines and main transmission couplings. UH-60A efficiency, vibration, and gear tooth strain data were taken (refs. 14 and 15). The transmission's mechanical efficiency at full power was 97.3 and 97.5 percent at inlet oil temperatures of 82 and 99 °C (180 and 210 °F), respectively. The highest vibration reading was 72 g's rms at the upper housing side wall. The largest stress found was 760 MPa (110 ksi) on the combining pinion fillet. Temperature and deflection data were also taken and are presently being analyzed.

The 3000-hp test stand is currently inactive and no additional transmission testing is planned at this time.

### Planetary Gear Test Stand

The NASA Lewis planetary gear test stand studies performance characteristics of planetary gear assemblies. The facility uses a regenerating torque loop where two OH-58 planetaries are mounted back-to-back with a drive motor on one end and a rotating torque actuator on the other end (fig. 8). The torque actuator loads the test planetary section with respect to the slave planetary section. The drive motor provides the speed and also supplies the power to overcome friction losses. The rig is capable of delivering 373 kW (500 hp) at 1620 rpm sun gear speed.

The test and slave planetaries have separate lubrication systems. Each system is comprised of 14 oil jets for lubrication of different areas of the planetary. The oil flow through each jet can be individually controlled. This makes possible an extensive study of the effect of lubrication on planetary performance.

The rig became operational in March 1986 and efficiency studies of a 313-kW (420-hp) OH-58 four-planet assembly were performed (ref. 16). The planetary has a reduction ratio of 4.67:1. Parametric studies of speed, load, and lubricant type, temperature, and flow were run. All parameters affected efficiency and experimental results were compared to analytical predictions. Future rig plans include the study of the sun gear dynamics (strains and stresses) and comparison with analytical codes. Also, various planetary configurations such as three- or four-planet, cylindrical or spherical planet bearings, or low or high contact ratio gears are planned.

### Spur Gear Fatigue Apparatus

Gear research began at NASA Lewis late in the 1960's. The work concentrated on materials and lubrication and established a unique data base in aviation applications. The NASA Lewis gear fatigue test apparatus became operational in 1972, supplying valuable data on gear materials, lubrication,

and life analysis. There are currently four running gear fatigue rigs at NASA Lewis.

The spur gear fatigue test apparatus (fig. 9) operates on a four-square principle. One slave gear is equipped with loading vanes and oil pressure on the vanes produces a torque on the slave gear shaft. The torque is transmitted through the test gears and back to the slave gears. The torque on the test gears, which depends on the hydraulic pressure applied to the load vanes, loads the gear teeth to the desired stress level. A constant-speed motor is connected by a belt to the drive shaft and various rig speeds are available by changing pulleys. The rig is capable of delivering 75 kW (100 hp) at the normal operating speed of 10 000 rpm. The standard test gear is a 28-tooth, 8-diametral pitch spur gear with a pitch diameter of 8.89 cm (3.50 in.) and tolerances per American Gear Manufacturers Association (AGMA) class 12.

The standard gear material used in the aircraft industry today is AISI 9310, a high-alloy steel. With the ever-increasing trends of higher loads and higher temperatures, however, improved materials are desired to enhance aircraft transmission operational levels. The surface fatigue life for a variety of proposed materials have been evaluated using the NASA Lewis fatigue rig over the past two decades (fig. 10). Some of the materials tested were: Super Nitralloy (ref. 17), AISI M-50 (refs. 17 and 18), Vasco X-2 (ref. 19), CBS 600 (ref. 19), CBS 1000M (ref. 20), EX-53 (ref. 20), and hot forged powder metal AISI 4620 and 4640 (ref. 21). Gear surface fatigue strength and bending strength improvements by shop peening were also studied (ref. 22). In addition, lubricant and lubricant additives were found to significantly affect gear surface fatigue life (refs. 23 and 24).

In the lubrication and cooling of gears, the gear bulk temperature is a controlling factor in the gear scoring or scuffing mode of failure. The depth of penetration of the oil jet into the gear blank plays an important role in the gear blank temperature. Lubricant oil jet tests were performed in the spur gear fatigue test apparatus (fig. 11). A specially designed test gear cover was made for viewing the test gears and photographing the lubrication phenomenon. A high-speed movie camera was used to photograph the oil jet. A high-speed air-cooled stroboscopic system was used to provide flash tube lighting that was synchronized with the high-speed camera. The camera speed was set to give a frame for each tooth space movement. A white pigment was added to the gear lubricant and a 1000-W xenon lamp was used to illuminate the lubricant. The experimentally measured oil impingement depths were used to verify analytical predictions (ref. 25).

For further knowledge in the lubrication and cooling of gears, gear tooth temperature measurements were made using the spur gear fatigue test apparatus. The gear surface temperatures were measured with a fast response infrared radiometric microscope that used a liquid nitrogen cooled detector (fig. 12). The microscope was capable of measuring transient temperatures up to 20 000 Hz. Experimental measurements of gear tooth average surface temperatures as a function of speed, load, and lubricant oil pressure were made and compared to analytical finite element methods (ref. 26).

The spur gear fatigue test apparatus is currently being used in support of the Navy's Helicopter Lubrication Program (ref. 12). Improved load-carrying capacity lubricants are supplied by the Navy and the effect of the lubricant

on gear fatigue life is being studied. The spur gear rig is also continuing to test advanced gear materials (currently AISI M-50 Nil), advanced manufacturing processes (currently CBN grinding), and modified tooth profiles and determining their effects on life.

### Bevel Gear Apparatus

Spiral bevel gears are used extensively in helicopter transmissions to transfer power between nonparallel, intersecting shafts. The NASA Lewis bevel gear apparatus is similar to the spur gear fatigue test apparatus but applied to spiral bevel gears. A torque-regenerative principle is used and torque is applied by a hydraulic loading device. The rig was designed for capabilities up to 559 kW (750 hp) at a pinion gear speed of 15 000 rpm. The bevel gear apparatus test gears (fig. 13) have a 35° spiral angle, a 1 in. face width, a 90° shaft angle, and a 22.5° pressure angle. The pinion has 12 teeth and the gear has 36 teeth. The rig is intended for fatigue testing, noise and vibration testing, and lubrication studies. The effect of various tooth profiles on performance is also under study.

### High Speed Gear Test Stand

For low gear speed operation, gear lubrication is often accomplished by immersion, splash, drips, or impingement techniques. At high speed operation the primary role of the lubricant is changed from preventing metal-to-metal contact to system cooling. This requirement usually cannot be met by standard lubrication techniques. Gear failures caused by micro-pitting or fatigue spalls could occur due to loss of oil film between teeth or inadequate oil flow. Therefore, high speed gear operation requires extended studies.

The high speed gear test stand is the latest gear research rig installed at NASA Lewis (fig. 14); the test section was designed and built by Allison Gas Turbine. The objective of the rig is the study of lubrication techniques, noise, and vibration at very high spur gear pitch line velocities. The rig is basically a scaled-up version of the spur gear rig with capabilities of 2234 kW (3000 hp) at shaft speeds of 10 000 rpm, and pitch line velocities to 152.4 m/sec (30 000 ft/min). The pinion test gear has an 11-in. pitch diameter, a 4 diametral pitch, and a 25° pressure angle and meshes with a 13-in. pitch diameter gear. The rig has just currently been made operational and lubrication studies and gear temperature measurements are being performed.

### Gear Noise Test Stand

Helicopter interior noise and vibration are of concern because of passenger comfort and the effect on pilot and crew efficiency. The standard approach in quieting the helicopter is to add cabin acoustic material which, in turn, adds weight. Most experts agree that the major source of cabin noise originates from the gearing in the main transmission. Presently, the NASA helicopter transmission program is emphasizing noise reduction technology (ref. 27).

At the start of 1987, NASA Lewis initiated a transmission noise reduction program. One aspect of the program entails the fabrication of a gear noise



test stand. The test stand objective is to provide experimental verification of a noise propagation analytical code presently being developed. The analytical code will model a set of spur gears in contact and determine the dynamic loads and excitation forces originating from the mesh. The code will then predict the noise propagation to the surroundings using the gear excitation forces and the support structure transfer functions.

The conceptual design of the rig consists of a drive motor, a pair of test gears, and a dynamometer loading device. The drive motor and dynamometer have a capability of about 130 kW (175 hp) at 6000 rpm. The initial gears to be tested will be from the spur gear fatigue apparatus (28 teeth, 8 diametral pitch, 8.89 cm pitch diam). The test gears supporting structure and shafting is presently in the design stage. Capabilities of variable gear ratios, variable support stiffness and damping, and shaft misalignment are being considered. It is anticipated that the rig will be operational around the beginning of 1988. The projected data to be extracted from the rig are: sound pressure levels and acoustic intensities from microphones, vibration spectra from housing-mounted accelerometers, displacements and forces at support structure mounts, and dynamic strains on gear teeth. The analytical and experimental noise data from this program will be fundamental to understanding gear noise and can be used in the future reduction of helicopter interior noise.

#### CONCLUDING REMARKS

This report reviewed the current experimental activities on helicopter transmission testing at NASA Lewis. The major efforts of the test stands can be classified as follows:

1. Full-scale transmission testing. Production-ready and prototype helicopter transmissions are tested to provide analytical code verification, baseline testing from which to assess the promised advantages of future designs and concepts, and to demonstrate advanced technology.

2. Advancing gear technology. Advanced materials, lubrication schemes, and gear geometries are being studied for a variety of applications to provide analytical verification and increase present gear operational capabilities.

3. Reducing gear noise. A current emphasis on gear noise entails construction of a gear noise rig to provide analytical verification and increase the understanding of gear noise for a future reduction of helicopter interior noise.

NASA Lewis has some unique and useful facilities which are available to the rotorcraft industry for research and testing of new and advanced concepts in rotary wing flight propulsion systems. Joint programs are being conducted by NASA, the U.S. Army, and the U.S. Navy to reduce the weight and noise and increase the strength and life of helicopter transmissions and develop the drive train technology needed for the next generation rotorcraft.

#### REFERENCES

1. Zaretsky, E.V., Townsend, D.P. and Coy, J.J. NASA Gear Research and its Probable Effect on Rotorcraft Transmission Design. NASA TM-79292, 1979.

2. Zaretsky, E.V., Coy, J.J. and Townsend, D.P. NASA Transmission Research and Its Probable Effects on Helicopter Transmission Design. NASA TM-83389, 1983.
3. Fischer, G.K., ed., Advanced Power Transmission Technology. NASA CP-2210, 1983.
4. Weden, G.J. and Coy, J.J. Summary of Drive-Train Component Technology in Helicopters. Gears and Power Transmission Systems for Helicopters and Turboprops, AGARD CP-369, AGARD, Paris, France, 1984, pp. 2-1 to 2-17. (NASA TM-83726).
5. Coy, J.J., Townsend, D.P. and Zaretsky, E.V. Gearing, NASA RP-1152, 1985 (Chapter 38 in Mechanical Design and Systems Handbook, 2nd ed., H. Rothbart, ed., McGraw-Hill, 1985).
6. Coy, J.J., Townsend, D.P. and Coe, H.H. Results of NASA/Army Transmission Research. USAAVSCOM-TR-87-C-3, 1987 (to appear in a NASA CP: 1987 NASA/ARMY Rotorcraft Technology Conference).
7. Mitchell, A.M. and Coy, J.J. Lubricant Effects on Efficiency of a Helicopter Transmission. Problems in Bearings and Lubrication, AGARD CP-323, AGARD, Paris, France, 1982, pp. 20-1 to 20-16. (NASA TM-82857).
8. Coy, J.J., Mitchell, A.M. and Hamrock, B.J. Transmission Efficiency Measurements and Correlations with Physical Characteristics of the Lubricant. Gears and Power Transmission Systems for Helicopters and Turboprops, AGARD CP-369, AGARD, Paris, France, 1984, pp. 20-1 to 20-15. (NASA TM 83740).
9. Lewicki, D.G. and Coy, J.J. Vibration Characteristics of the OH-58A Helicopter Main Rotor Transmission. NASA TP-2705, 1987.
10. Braddock, C.E. and Battles, R.A. Design of an Advanced 500 HP Helicopter Transmission. Advanced Power Transmission Technology, Fischer, G.K., ed., NASA CP-2210, 1983, pp. 123-139.
11. Folenta, D.J. Design Study of Self-Aligning Bearingless Planetary (SABP). NASA CR-159808, 1980.
12. Shimski, J.T. and Paskow, L.A. Future Trends for U.S. Naval Aviation Propulsion System Lubricants. Aviation Gas Turbine Lubricants, SAE, Warrendale, PA, 1985, pp. 95-102. (SAE Paper 851835).
13. Mitchell, A.M., Oswald, F.B. and Schuller, F.T. Testing of YUH-61A Helicopter Transmission in NASA Lewis 2240-kW (3000 hp) Facility. NASA TP-2538, 1986.
14. Mitchell, A.M., Oswald, F.B. and Coe, H.H. Testing of UH-60A Helicopter Transmission in NASA Lewis 2240-kW (3000 hp) Facility. NASA TP-2626, 1986.
15. Oswald, F.B. Gear Tooth Stress Measurements on the UH-60A Helicopter Transmission. NASA TP-2698, 1987.

16. Handschuh, R.F. and Rohn, D.A. Performance Testing of a Helicopter Transmission Planetary Reduction Stage. NASA TP- , 1987 (to be published).
17. Townsend, D.P. and Zaretsky, E.V. A Life Study of AISI M-50 and Super Nitralloy Spur Gears With and Without Tip Relief. J. Lubr. Technol., 1974, 96, 583-590.
18. Townsend, D.P., Bamberger, E.N. and Zaretsky, E.V. A Life Study of Ausforged, Standard Forged, and Standard Machined AISI M-50 Spur Gears. J. Lubr. Technol., 1976, 98, 418-425.
19. Townsend, D.P. and Zaretsky, E.V. Endurance and Failure Characteristics of Modified VASCO X-2, CBS 600 and AISI 9310 Spur Gears. J. Mech. Des., 1981, 103, 506-515.
20. Townsend, D.P. Surface Fatigue Life and Failure Characteristics of EX-53, CBS 1000M, and AISI 9310 Gear Materials. NASA TP-2513, 1985.
21. Townsend, D.P. Surface Fatigue Life and Failure Characteristics of Hot Forged Powder Metal AISI 4620, AISI 4640, and Machined AISI 4340 Steel Spur Gears. NASA TM-87330, 1986.
22. Townsend, D.P. and Zaretsky, E.V. Effect of Shot Peening on Surface Fatigue Life of Carburized and Hardened AISI 9310 Spur Gears. NASA TP-2047, 1982.
23. Townsend, D.P. and Zaretsky, E.V. Effect of Five Lubricants on Life of AISI 9310 Spur Gears. NASA TP-2419, 1985.
24. Scibbe, H.W., Townsend, D.P. and Aron, P.R. Effect of Lubricant Extreme-Pressure Additives on Surface Fatigue Life of AISI 9310 Spur Gears. NASA TP-2408, 1984.
25. Townsend, D.P. and Akin, L.S. Study of Lubricant Jet Flow Phenomena in Spur Gears - Out of Mesh Condition. J. Mech. Des., 1978, 100, 61-68.
26. Townsend, D.P. and Akin, L.S. Analytical and Experimental Spur Gear Tooth Temperature as Affected by Operating Variables. J. Mech. Des., 1981, 103, 219-226.
27. Coy, J.J., Handschuh, R.F., Lewicki, D.G., Huff, R.G., Krejsa, E.A. and Karchmer, A.M. Identification and Proposed Control of Helicopter Transmission Noise at the Source. USAAVSCOM-TR-87-C-2, 1987 (to appear in a NASA CP: 1987 NASA/ARMY Rotorcraft Technology Conference).

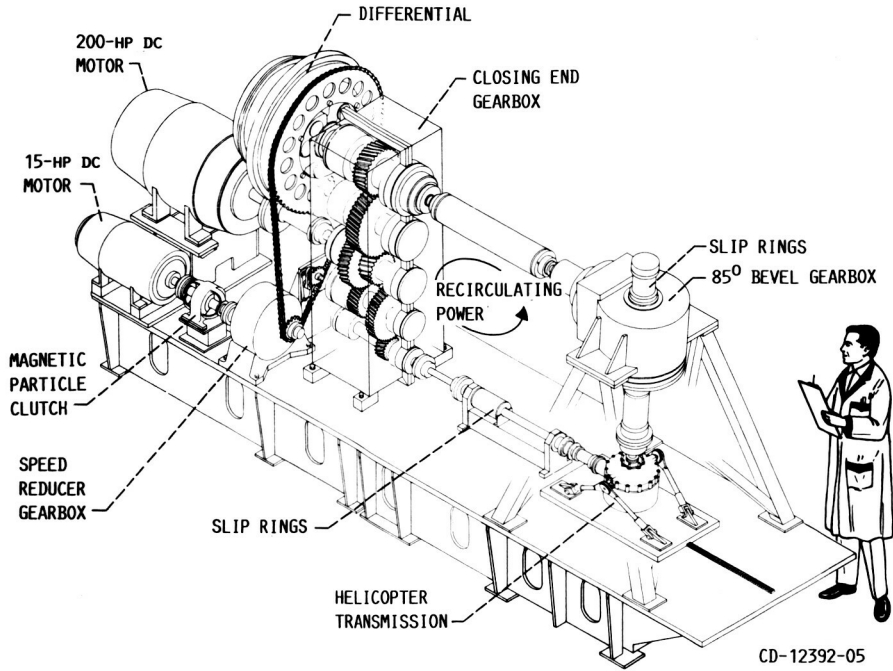

FIGURE 1. - NASA LEWIS 500-HP HELICOPTER TRANSMISSION TEST STAND.

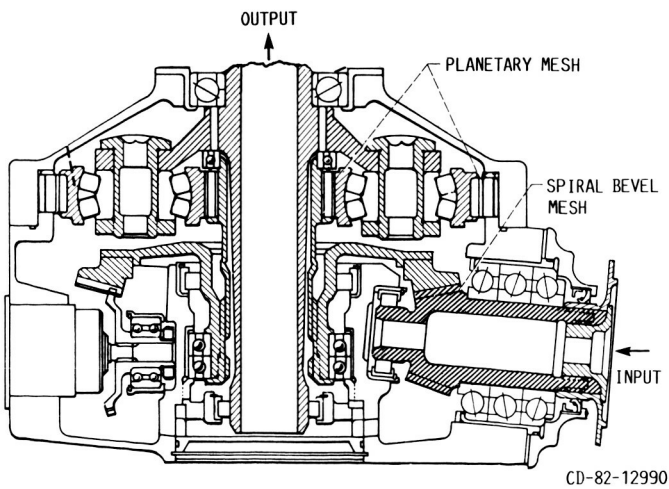

FIGURE 2. - OH-58A HELICOPTER MAIN ROTOR TRANSMISSION.

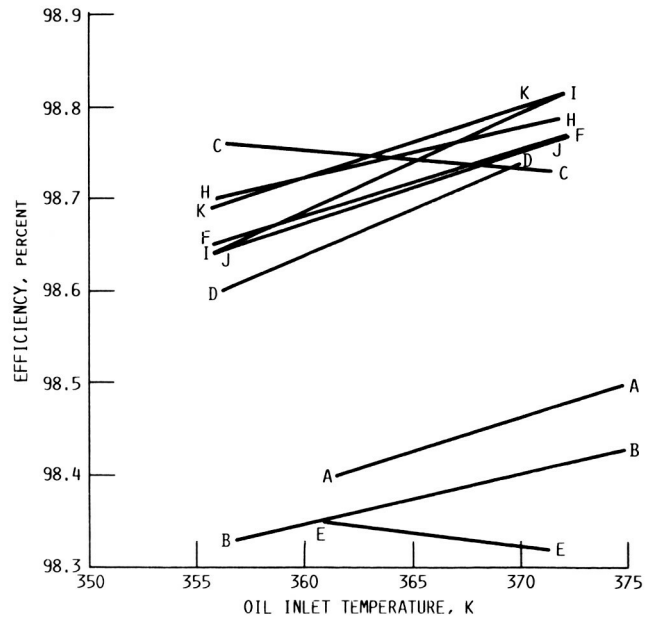

FIGURE 3. - OH-58A TRANSMISSION EFFICIENCY FOR VARIOUS LUBRICANTS (FROM REF. 7).

ORIGINAL PAGE IS  
OF POOR QUALITY

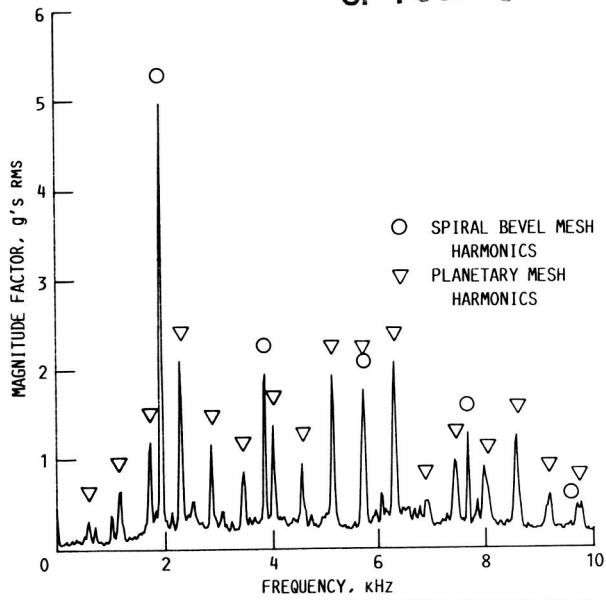
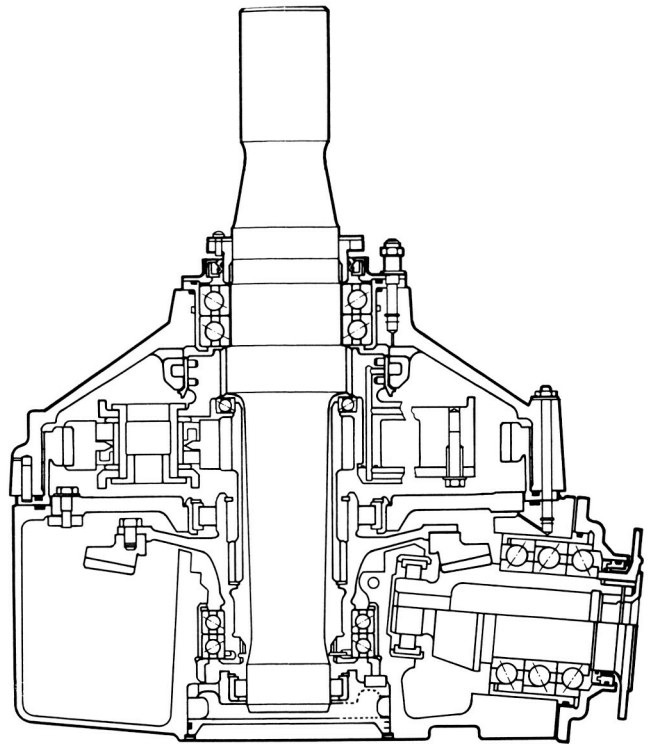
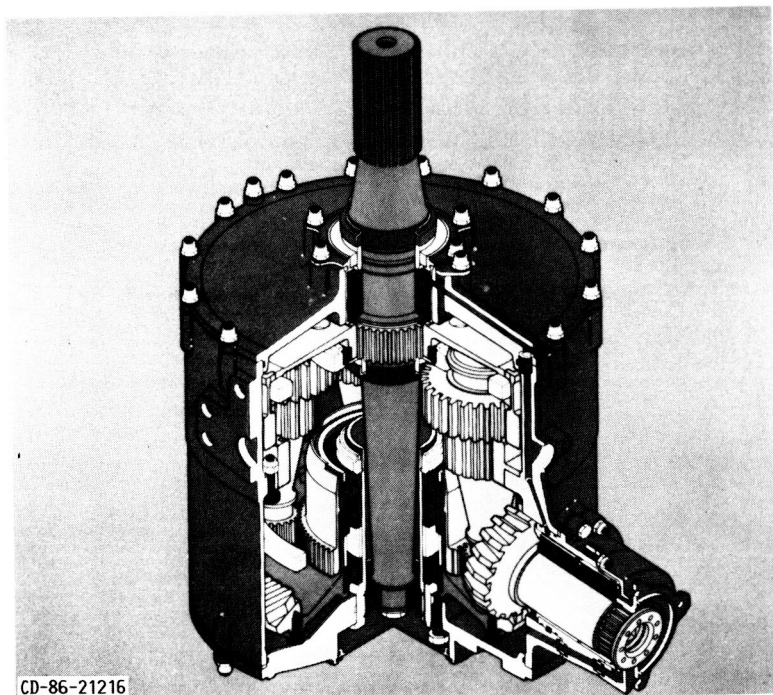

FIGURE 4. - OH-58A TRANSMISSION VIBRATION SPECTRUM OF AN ACCELEROMETER MOUNTED ON THE RING GEAR HOUSING (FROM REF. 9).



CD-83-13657

FIGURE 5. - 500-HP ADVANCED TECHNOLOGY TRANSMISSION.



CD-86-21216

FIGURE 6. - 450-HP SELF-ALIGNING BEARINGLESS-PLANETARY TRANSMISSION.

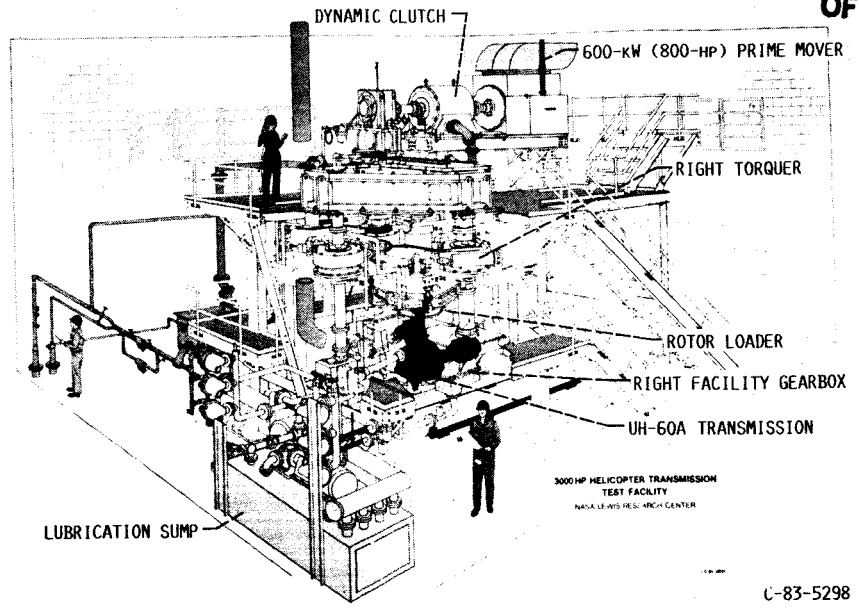

(A) ISOMETRIC VIEW.

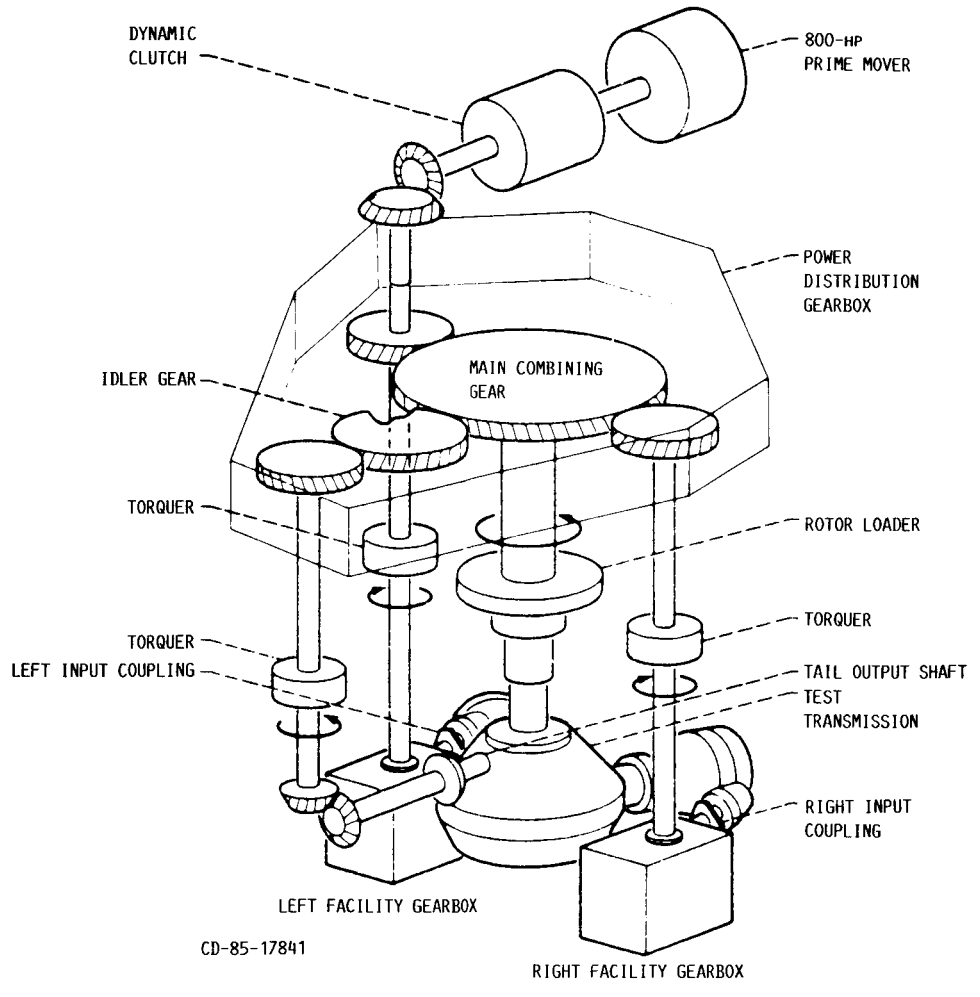

(B) SCHEMATIC VIEW.

FIGURE 7. - NASA LEWIS 3000-HP HELICOPTER TRANSMISSION TEST STAND.

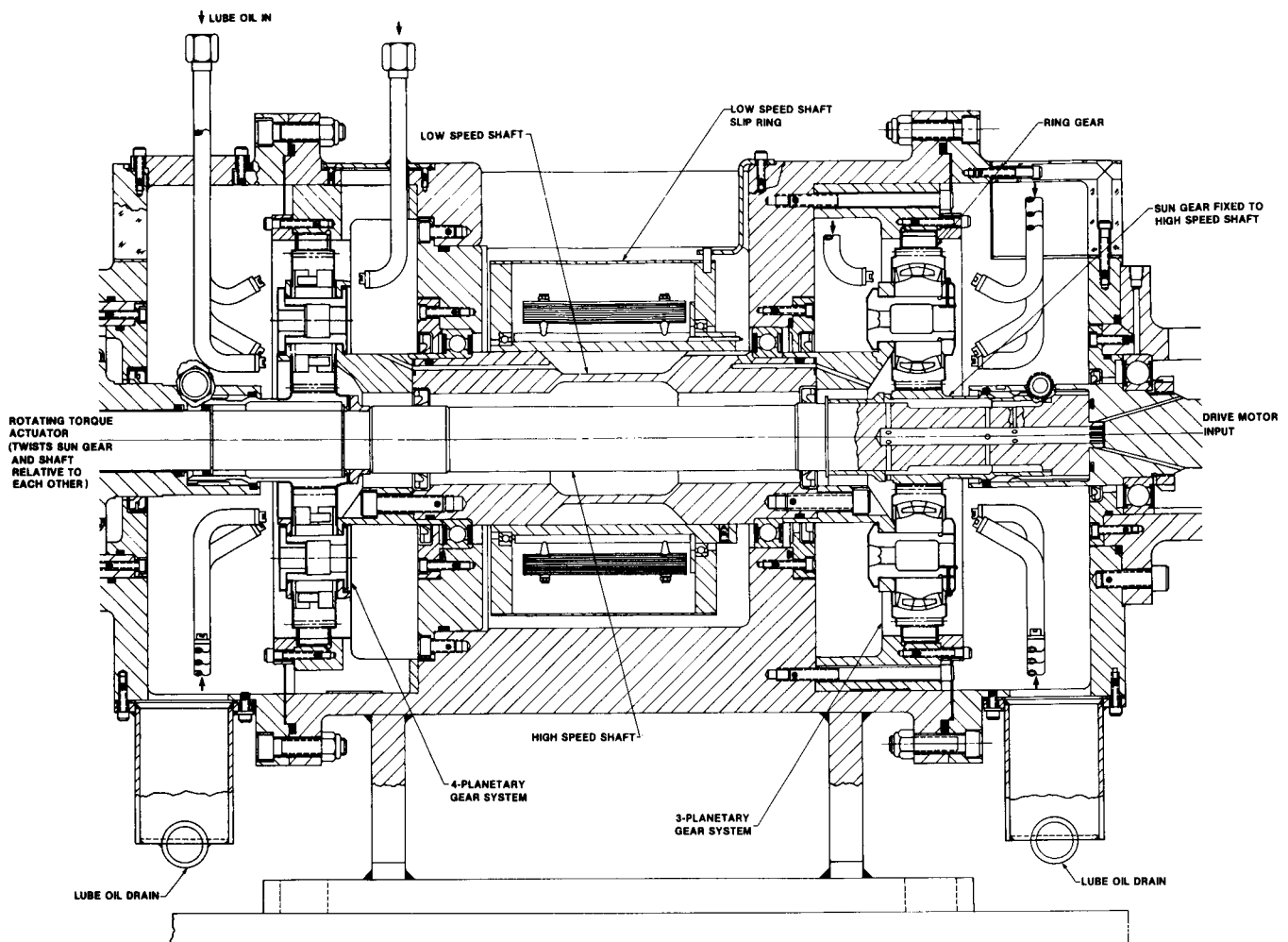

CD-85-17838

FIGURE 8. - NASA LEWIS PLANETARY GEAR TEST STAND.

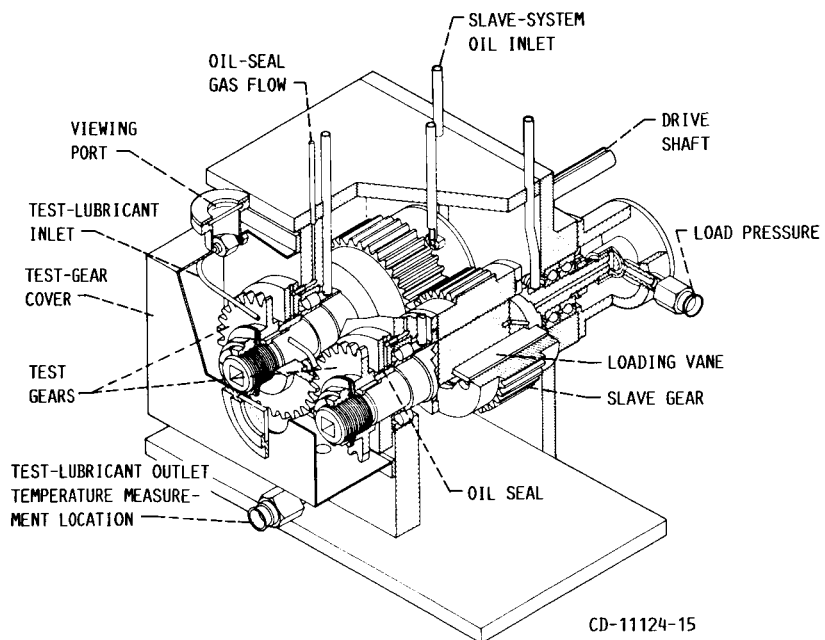

CD-11124-15

FIGURE 9. - NASA LEWIS GEAR FATIGUE TEST APPARATUS.

ORIGINAL PAGE IS  
OF POOR QUALITY

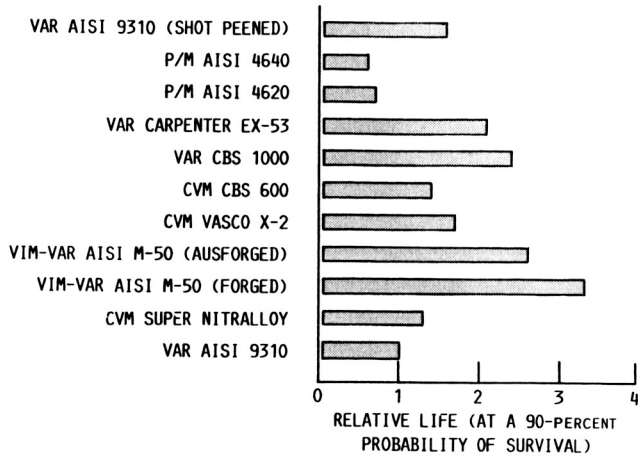

FIGURE 10. - RELATIVE PITTING FATIGUE LIVES OF VARIOUS AIRCRAFT QUALITY GEAR STEELS.

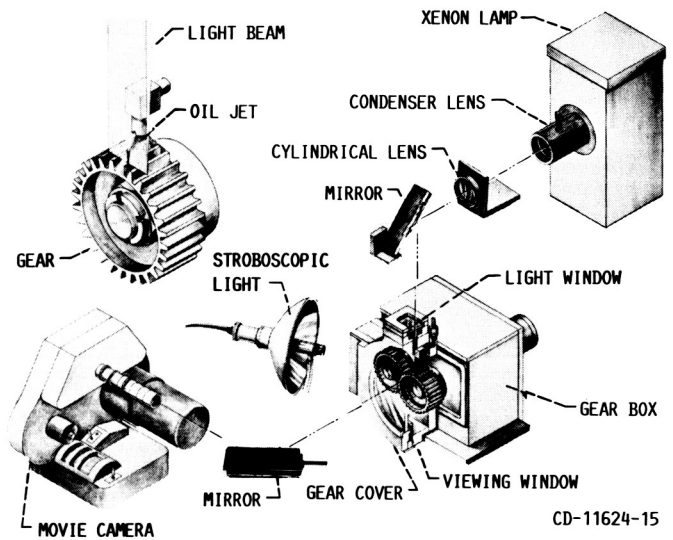

FIGURE 11. - THE NASA LEWIS GEAR FATIGUE TEST APPARATUS MODIFIED FOR OIL JET PENETRATION STUDIES.

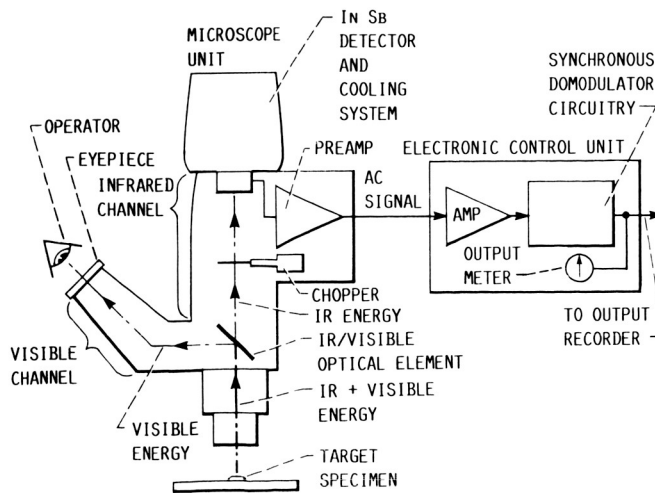

FIGURE 12. - SCHEMATIC OF INFRARED RADIOMETRIC MICROSCOPE.



ORIGINAL PAGE IS  
OF POOR QUALITY

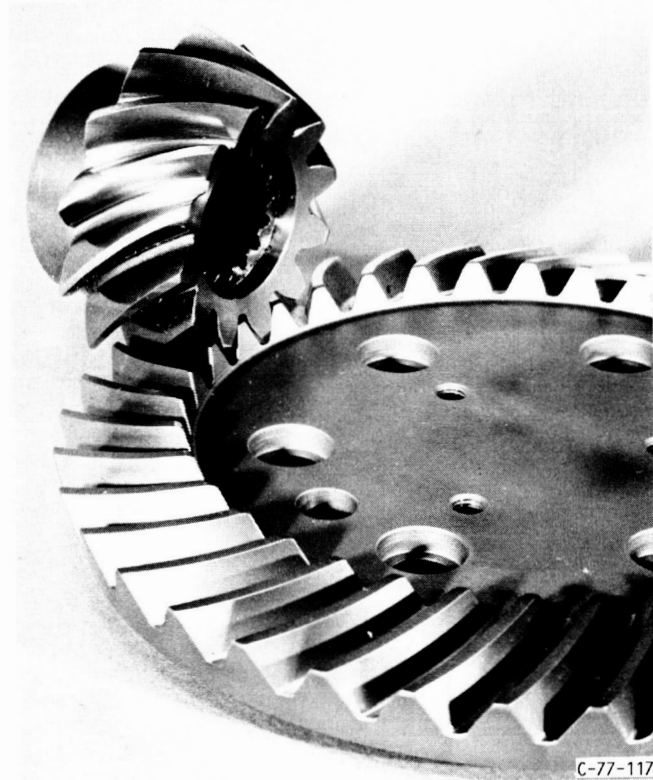

FIGURE 13. - NASA LEWIS BEVEL GEAR APPARATUS TEST GEARS.

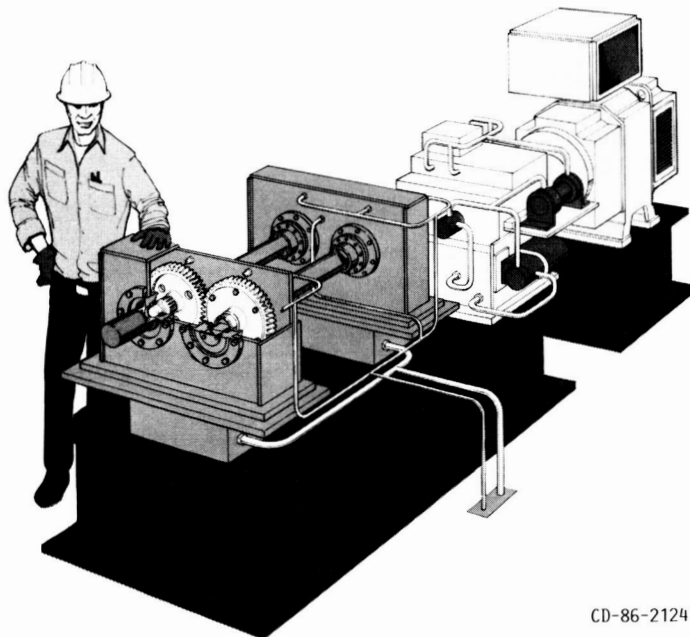

FIGURE 14. - NASA LEWIS HIGH SPEED GEAR TEST STAND.

1. Report No. <b>NASA TM-89912 AVSCOM TR-87-C-10</b>		2. Government Accession No.		3. Recipient's Catalog No.	
4. Title and Subtitle  <b>Helicopter Transmission Testing at NASA Lewis Research Center</b>				5. Report Date	
				6. Performing Organization Code  <b>505-63-51</b>	
7. Author(s)  <b>David G. Lewicki and John J. Coy</b>				8. Performing Organization Report No.  <b>E-3603</b>	
				10. Work Unit No.	
9. Performing Organization Name and Address  <b>National Aeronautics and Space Administration Lewis Research Center Cleveland, Ohio 44135</b>				11. Contract or Grant No.	
				13. Type of Report and Period Covered  <b>Technical Memorandum</b>	
12. Sponsoring Agency Name and Address  <b>National Aeronautics and Space Administration Washington, D.C. 20546</b>				14. Sponsoring Agency Code	
15. Supplementary Notes  <b>Prepared for the Testing of Aerospace Transmissions Conference sponsored by the Institute of Mechanical Engineers, Derby, England, June 10, 1987.</b>					
16. Abstract  <b>Since 1970 the NASA Lewis Research Center and the U.S. Army Aviation Systems Command have shared an interest in advancing the technology for helicopter pro- pulsion systems. The current experimental activities at NASA Lewis on helicopter transmission testing is reviewed. The major goals are to reduce weight and noise and to increase life and reliability. The current rigs at NASA Lewis consist of full-scale helicopter transmission testing, a base effort in gearing technology, and a future effort in noise reduction technology.</b>					
17. Key Words (Suggested by Author(s))  <b>Helicopters; Transmissions; Transmission testing; Gears; Lubrication; Materials</b>			18. Distribution Statement  <b>Unclassified - unlimited STAR Category 37</b>		
19. Security Classif. (of this report)  <b>Unclassified</b>		20. Security Classif. (of this page)  <b>Unclassified</b>		21. No. of pages  <b>17</b>	22. Price*  <b>A02</b>