

P-55

IN-05  
DATE OVERRIDE  
97836

---

# Experimental Techniques for Three-Axes Load Cells Used at the National Full-Scale Aerodynamics Complex

---

Michael R. Dudley

---

(NASA-TM-86693) EXPERIMENTAL TECHNIQUES FOR  
THREE-AXES LOAD CELLS USED AT THE NATIONAL  
FULL-SCALE AERODYNAMICS COMPLEX (NASA) 55  
F Avail: NTIS EC A04/MF A01 CSCL 01C

N87-28546

Unclas  
G3/05 0097836

September 1985

---

# **Experimental Techniques for Three-Axes Load Cells Used at the National Full-Scale Aerodynamics Complex**

---

Michael R. Dudley, Ames Research Center, Moffett Field, California

September 1985



National Aeronautics and  
Space Administration

**Ames Research Center**  
Moffett Field, California 94035

## SUMMARY

This memorandum provides the necessary information for an aerodynamic investigation requiring load cell force measurements at the National Full-Scale Aerodynamics Complex (NFAC). Included here are details of the Ames 40 by 80 three-component load cells; typical model/load cell installation geometries; transducer signal conditioning; a description of the Ames Standard Computations Wind Tunnel Data Reduction Program for Load Cells Forces and Moments (SCCELLS), and the inputs required for SCCELLS. The Outdoor Aerodynamic Facilities Complex (OARF), a facility within the NFAC where three-axes load cells serve as the primary balance system, is used as an example for many of the techniques, but the information applies equally well to other static and wind tunnel facilities that make use of load cell balances.

This paper can serve either as a user guide for NASA and contract engineers who are preparing to conduct an investigation at the OARF or at the NFAC, or as a description of techniques, data systems, and hardware that is currently used for ground-based aerodynamic investigations which measure forces with three-axes load cells.

## INTRODUCTION

Ground-based aerodynamic investigations of full-scale models require a means of measuring the forces that are generated by the model. At the National Full-Scale Aerodynamics Complex (NFAC), strain gage transducer load cells, internal balances, and external balances are used for this purpose. For test conditions where the model weight exceeds the capacity of the internal balances (1250 kg), and where the external balances dedicated to the full-scale wind tunnels cannot be utilized, combinations of load cells are used to form a balance system (for example, outdoor testing or when measuring isolated forces on model components. The two types of load cells used at the NFAC are single axis and three component. The three component load cells (three-AX LC) are designed to measure forces in three orthogonal directions. The single-axis load-cells (one-Ax LC) are capable of force measurement in only one direction.

## LOAD CELLS

The Ames 40 by 80 three-component load cells were designed at Ames specifically for large-model testing at the NFAC. The general arrangement of a three-Ax LC is a

pin bushing suspended in a flat plate by load flexures. The flat plate is attached perpendicular to a mounting pad. The pad is drilled with the standard 40 by 80 5-in. bolt circle, figure 1. The flexures are instrumented with resistance-type, four-arm strain gage bridges. Each bridge (or in the case of redundant bridges, system of bridges) is designed to measure force in one of the three orthogonal directions. Hereafter each bridge network will be referred to as a gage of the load cell; i.e., the bridge circuit measuring axial force on three-Ax LC number one would be the axial gage of load cell number one.

A single-axis load cell consists of a single flexure instrumented with a four-arm strain gage network. It is only capable of unidirectional force measurements and will be damaged if loaded perpendicular to its axis. On occasion three, one-Ax LC are used in combination so that all three axes intersect a single point in space. This is done to form a single, three-component pseudoload cell. When this is done, each one-Ax LC is referred to as a gage or component of the pseudoload cell. These pseudoload cells are a convenient convention that simplifies the Ames Standard Computations Wind Tunnel Data Reduction Program for Load Cells Forces and Moments (SCCELLS) used at the NFAC.

All load cells used in experimental investigations at Ames are calibrated at the Ames Reliability and Quality Assurance laboratory (RQ&A). The work includes resistance calibrations and loadings to determine the repeatability and linearity of the voltage to force ratios (primary conversions constants). For the three-Ax LC, interactions (the apparent change of a gage force when a perpendicular force is applied) are also determined. The primary voltage/force conversions generally have inaccuracies of less than 0.1% for the one-Ax LC and 0.3% for the three-Ax LC. Installed system inaccuracies are usually about 1% of the full-scale range of the gage. An example of a typical load cell calibration for one gage of a three-Ax LC by RQ&A is included in appendix A.

Although calibrations of the side force gages of the three-Ax LC are usually good in the laboratory, historically it has been difficult to measure the side force on a model at the Outdoor Aerodynamics Facility Complex (OARF), a facility within the NFAC. This is thought to be a result of the installation methods which are discussed in the following sections.

## INSTALLATION

### Conventional Model Installations

Normally, models are mounted at the NFAC on a support system which consists of two main struts and a tail strut. The model height and pitch angle are varied using different combinations of strut tips or extensions, and a continuously telescoping tail strut. The tail strut is supported at its base by a gimbal. It is possible to vary the tread of the main struts and their distance from the tail strut. Discrete model installation heights are between 0.5 m and 6.5 m, at the OARF, and at the 40-by 80-Foot Wind tunnel, and are up to 15 m in the 80 by 120 test section. An

example of a typical model support strut installation at the OARF is shown in figure 2. (For a more complete explanation of model installations see the "Guides for Planning Investigations" provided by the Low Speed Wind Tunnel Investigations Branch, NASA Ames Research Center, Moffett Field, CA.)

A model is attached to struts by the load cell-clevis assembly, figure 3. These special clevises are fixed to the top of the struts to provide a pin joint support for the load cells, which are secured to the model. Model support hardware from the clevis pin down, is nonmetric (no forces measured). Everything from the pin up is metric. The point of application for the resultant forces measured by the load cells (reaction point) is assumed to be on the pin axis in the plane of symmetry of the load cell (fig. 1). It should be noted that care must be taken when instrumentation and service leads are draped across this metric joint, or unmeasured interference forces can result.

Outdoor ground-based aerodynamic investigations often involve testing with models that are powered by actual jet engines. The hot exhaust gages from the engines can cause slight changes in the model's tread distance between the main load cells. To prevent fouling (interference) between the load cell and its clevis, and still allow for model growth, only the tail strut and one main strut are shimmed to prevent lateral movement of the load cells relative to their pins. The shim/load cell contact is permissible since the portion of the load cell in contact with the pin is nonmetric. The third load cell is permitted to slide on the pin to allow for growth of the model tread that is due to thermal expansion.

Model support for any aerodynamic test system is designed as slender as possible so as to minimize aerodynamic interference. When a large mass, such as a model, is placed on top of slender supports the neutral position (undeflected vertical columns) can become statically unstable. Assuming that the supports are strong enough to prevent buckling, the stable position occurs when the lateral force that is due to model weight and strut deflection angle is balanced by the spring force of the deflected strut tip.

$$(\Delta Y)(K) = (\text{Weight})(\sin \delta) = \text{Force}$$

where  $\Delta Y$  is the lateral deflection,  $K$  is the strut spring constant, and  $\delta$  is the angular deflection of the strut. The flexibility of the support system should not be overlooked when testing heavy models. Strut deflections of a tenth of a degree will cause lateral loads of 375 N when a 25,000-kg model is being supported.

The model support system currently in use at the Ames OARF is very rigid in the longitudinal direction; however, lateral side deflections in excess of one tenth of a degree have been observed. The difficulty in measuring side-force mentioned earlier is believed to result from the bistable nature of a side-force zero bias. Hysteresis loops in the side-force measurements of the order of 600 kg are not uncommon when heavy models are tested. A new model support system is planned for the OARF and will be installed at some time in the future.

## Jet-Propulsion Test stand Installation

The NFAC Jet-Propulsion test stand was developed to accommodate the testing of engine components such as nozzles and inlets and small models that can be conveniently attached to a platform. The test stand consists of a metric table suspended by links from a nonmetric support platform. All the supporting and restraining links contain single-axis load cells that determine the forces which are transmitted by the links. The links are arranged so that the metric table is hung by four vertical links. The motion of the table is confined in the horizontal plane by two axial and two side links. Typically only three of the four horizontal links are used for a nonredundant system. The axes of all the links are positioned so they intersect at no more than four points in space. Figure 4 illustrates how this is achieved by various coplanar link orientations.

The four points define the location of four pseudo load cells. The individual gage forces are measured by the one-Ax LC that corresponds to the appropriate axis of the pseudo load cell. When assigning single-axis load cells as components of pseudo load cells, remember that the one-Ax LC can only be assigned once. For example, if the forward side link is to be defined as side-force for load cell one (the load cell at the forward left), there would be no side-force gage for load cell two (forward right).

When installing the load-links in the Jet-Propulsion test stand, care must be taken not to induce any adverse preloads while tightening the links. For a detailed description of the link installations, see appendix B.

### Load Cell Number Assignments

In the data reduction program SCELLS reference to a particular load cell gage is made via the subscripts (m,n) (see table 1). The subscript "m" denotes the component direction; 1 = X (axial), 2 = Y (side), and 3 = Z (normal). The "n" subscript indicates the load cell number and has a maximum value of four.

Although any numbering assignments that are used consistently throughout a test are acceptable, it is recommended that the conventions above be followed whenever possible to avoid confusion when dealing with the instrumentation and programming groups.

### LOAD CELL POSITION AND ORIENTATION

#### Reaction Point Moment Arm

The position of each load cell or pseudo load cell is defined in a cartesian coordinates system which is parallel to the model's body axes. The origin of this system is located at the moment center of the model. (The moment center can be any arbitrary point in space but usually has some physical significance, such as the

predicted center of gravity of the aircraft being modeled.) The positive directions for these coordinates are defined as:

Positive X, in the positive drag direction, axial to the rear, parallel to the axis of the model.

Positive Y, in the positive side force direction, to the right, perpendicular to the model's plane-of-symmetry.

Positive Z, in the positive lift direction, up, normal to the X- and Y-axes.

A load cell placed to the rear, right, and above the moment center would have all positive coordinates.

When it is necessary to define the load cell as a point in space, such as for determining distances to the moment center, the reaction point discussed above, figure 1, should be used as that point.

The coordinates of each load cell are input to SCELLS as the constants XYZLCM (m,n). In this case, "m" indicates the direction of the measurement (either 1, 2, or 3 as defined above for axes directions) and "n" the load cell number. The XYZLCM values are used in the computation of the resultant moments as seen by the model so the lineal dimension in the moments will be the same units as the distances input, i.e., if force is being measured in pounds, inputting XYZLCM in feet will result in moments calculated in foot-pounds.

#### Angular Orientation

When load cells are mounted on a model, there are often angular misalignments between the axes of the load cells and the model. This can occur either from slight errors in the fabrication of the mounting pads or in the intentional rotations that are due to some special installation requirements. All these angles must be accounted for during data reduction in order to avoid cosine errors when resolving the forces. To accomplish this, inputs must be made to SCELLS that define the angles that each model axis must be rotated to in order to align each one with the force measuring axis of each load cell.

Generally, it is only necessary to make rotations about one or two axes; however, should it be required to rotate the axes through three angles the order of rotation and how the angles are referenced become important. For the simple case of two angles or less or for angles of less than five degrees, the program inputs for load cell "n" are:

XLCPsi(n), yaw angle of load cell "n"; Rotation about the Z axis, positive angles occur when the forward edge of the load-cell is to the left of a line parallel to the model plane of symmetry.

XLCTHE(n), pitch angle of load cell "n"; Rotation about the Y axis, positive angles occur when the forward edge of the mounting pad is higher than the rear edge.

XLCPHE(n), roll angle of load cell "n"; Rotation about the X axis, positive angles occur when the right edge of the mounting pad is higher than the left edge.

The angles are illustrated in figure 5. All angles are measured in degrees.

For the more complicated case of three rotations of significant magnitude, the following rules apply: The angles must be determined in the eulerian order, XLCPSI(n), XLCTHE(n), XLCPHE(n); the angles are each equal to a rotation for the model's body axes that brings a specific axis coincident with a particular load cell's axis; for each load cell the model axes are rotated in the sequence mentioned above. In detail:

XLCPSI(n), the model's axes are rotated about their Z-axis until the model's Y-axis is in the Y-Z plane of the load cell.

XLCTHE(n), the intermediate axes are rotated about their Y-axis until the X-axis is coincident with the load cell's X-axis.

XLCPHE(n), the second intermediate axes system is rotated about its X-axis until all the axes are coincident with the load cell's axes system.

The positive sense of the angles are defined according to the right-hand rule which states: Clockwise rotations are positive when the viewer is facing in the positive direction of the axis of rotation. In this case the positive sense of the axes of rotation is the same as described above for the reaction point moment arm; +X is rearward, +Y is to the right, and +Z is in an upward position.

#### CONVERSION CONSTANTS (data reduction)

The load cell is a transducer that produces an electrical signal whose voltage is proportional to the force experienced by the cell. The signal conditioning and data acquisition networks amplify the signal, convert it to digital counts proportional to the voltage, and record a time-averaged value of the counts in the computer storage area. To translate the recorded value into engineering units that reflect the actual loads measured, it is necessary to multiply the counts by a conversion constant. The following paragraphs give a brief summary of the signal conditioning methods and define the conversion constants used by the data reduction program SCELLS. An explanation of how the constants are obtained by the engineer is provided.



## SIGNAL CONDITIONING

The change in a load cell's signal output is proportional to the change in the force which is applied to the load cell and the excitation voltage which is applied to the bridge network. This signal can be increased by a voltage amplifier before being converted to digital counts. After the signal is in a digital form, additional gains can be made by the signal conditioning cards. The digital gains are often referred to as programmable gains by virtue of their ability to be set by a computer operator during initialization. Programmable gains should not be confused with any gains or conversions which are written into data reduction programs.

As the systems used at the NFAC are presently configured, voltage amplification is made with Newport or Pacific amplifiers. Typical gain adjustments on these amps are 1, 2, 5, 10, 20, 50, 100, 200, 500, 1000. Any multiplexed signals are conditioned by RMDU (remote multiplexing-demultiplexing unit) cards. The PSF (preamplifying sample filtering) cards have set hardware gains with 128 being the most common one. The AMX (analog to digital multiplexing) and DMX (digital multiplexing) cards are also used for signal conditioning. All signals that will be passed to the computer are multiplexed and go through the RCU (RMDU control unit). The RMDUs have fixed conversion ratios of 3200 or 3333 counts per volt for any multiplexed analog signal. This acts as an additional gain independent of the voltage or programmable gains. The binary programmable gains are set by the computer operator and can have the values of 1, 2, 4, 16, 64, 128, 256, 512. (Binary except for 8 and 32.)

### PRIMARY CONVERSION CONSTANTS, CLDCLS(s, m, n); [force/counts]

The CLDCLS constants are a product of the primary laboratory calibration and the signal gains between the load cell and the computer. The laboratory calibration provides the force to voltage relation for the load cell, and the voltage to counts change is determined by the product of the gains. The following equation illustrates how to calculate CLDCLS

$$\text{CLDCLS}(s,m,n) = \frac{\text{Primary conv.}}{(\text{Amp gain})(\text{A/D conv.})(\text{Programmable gain})}$$

In dimensional form:

$$[\text{force/count}] = \frac{[\text{force/volt}]}{[\text{volt/volt}][\text{count/volt}][\text{count/count}]}$$

(See appendix C for a sample numerical calculation of CLDCLS.)

The "m" and "n" subscripts indicate load cell component and number as explained above. The "s" subscript indicates whether the conversion constant applies for positive or negative loading (sometimes referred to as the bidirectional loading subscript). A subscript of "1" implies positive loading, "2" implies negative loading. The load cell calibration provided by the RQ&A lab (see appendix A) contains the computed primary slopes loaded in two directions, for each gage. When determining the CLDCLS constants, the user should verify that the lab definition of positive loading for each gage is consistent with the definitions of the data reduction program for positive loads as described above. If they are not, it may be necessary to exchange the "s" subscripts for the CLDCLS constants for the inconsistent gages.

LABORATORY RCAL VALUES, XINCAL(m, n); [counts]

Although the laboratory calibrations are performed with a constant and well-documented excitation voltage applied to the bridge networks, the same conditions do not always occur during the experimental investigation. The rcal (resistance calibration) is a means of determining differences that occur between the laboratory instrumentation's power supply, resistance, and amplification, and the instrumentation network used during testing.

An rcal is accomplished by temporarily placing a known precision resistor across a leg of the strain gage bridge and recording the signal voltage. Since the signal output is proportional to the excitation voltage, any variation in supply voltage will be reflected in the rcal. Multiplying the data by the ratio of the laboratory rcal (XINCAL) and a recently recorded rcal will correct for any drift. If the model installation requires long electrical leads between the signal conditioner, where the rcal resistor is located, and the actual gage; the additional resistance will affect the calibration. In this event, an approximate correction of the data can be made by multiplying by the ratio of resistor installed for rcal measurement to the installed resistor plus the lead resistance; or more accurately the data can be shown as the ratio of inside and outside rcals.

$$FGAGE = FGAGE * \frac{RCAL(inside)}{RCAL(outside)}$$

An outside rcal is recorded with the rcal resistor in the same proximity to the gage as it is in the laboratory. The inside rcal is recorded in the conventional manner. Note that the ratio in either case should always be less than unity.

By taking the difference between the lab rcal and lab zero voltage readings and multiplying by the product of the gains for that gage, the XINCAL value for input to SCELLS in counts can be obtained. Examples of laboratory rcals can be found in appendix A and a sample calculation can be found in appendix C. The subscripts m and n follow the same convention described earlier.

## INTERACTIONS CONSTANTS

DADS(s,n), DADN(s,n), DSDA(s,n), DSDN(s,n), DNDA(s,n), DNDS(s,n)

The body of a three-component load cell is fabricated from a single piece of material. When a force is applied in a given direction, unavoidably, the gages perpendicular to the load also experience some deflection. These unwanted deflections result in "apparent" forces being indicated normal to an applied load. The computed gage forces can be corrected for interactions by multiplying the influence coefficient (interaction constant) times load to determine the magnitude of the apparent load, which is then subtracted from the affected gage reading.

For most of the Ames 40 by 80 load cells the interactions that are approximate linear functions of the applied load are well behaved. By definition these functions pass through zero, but there is often an inflection in the slope as it passes through the origin. To account for the slope change, constants are designated for both positive and negative applied loads. As a result, there are twelve interaction constants per load cell (two influences per axis times three axes, times two load directions).

As part of the laboratory calibration, the voltage output of the gages that are perpendicular to the loaded gage are recorded as a function of the test load. In order to evaluate the influence of the interactions, the change of the output voltage of the affected gage must be multiplied by its lab [force/voltage] conversion to obtain the apparent force that would result from the applied load. This interaction function, whose slope is in units of [force/force], is derived from the plot of apparent force vs an applied perpendicular test load (appendix A).

This slope (representing the change of the apparent gage force per change in perpendicular applied force) is the interaction constant. These constants are identified using the following convention. The slope of the apparent delta in normal force that is due to an applied axial load would be designated as DNDA(s,n). The s subscript indicates whether the applied load is positive, where s = 1, or whether the applied load is negative, where s = 2. The n subscript indicates the load cell number.

The following is a list of the six types of interactions:

DADS(s,n) Axial force delta caused by side force  
DADN(s,n) Axial force delta caused by normal force  
DSDA(s,n) Side force delta caused by axial force  
DSDN(s,n) Side force delta caused by normal force  
DNDA(s,n) Normal force delta caused by axial force  
DNDS(s,n) Normal force delta caused by side force

PRELOAD CONSTANTS, PRELD(m,n); [force]

Depending upon the model installation, some or all of the load cell flexures will experience a preload because of the model's dead weight. This preload shifts the bias of the load cells' zero condition from neutrally loaded to some finite level. In order for the data reduction program SCELLS to select conversion constants that are appropriate for the load direction, the true physical loading must first be determined. This is accomplished by comparing the force that is indicated by the gage to its preload. If the force indicated is greater than the preload, then the load cell flexure is truly experiencing a positive load.

Preloads have the opposite sense as measured forces; i.e., a model dead weight of 10,000 kg acts in the minus-lift direction, but is defined as a positive preload. The same convention applies in the other two coordinate directions.

Preloads are supplied by the test engineer in units of force and can either be estimated or measured at the time of model installation. The subscripts m and n represent the same parameters as discussed above for the CLDCLS constants (direction and load cell number).

TEMPERATURE CORRECTION COEFFICIENT, CCLDTC(n)

AND LOAD CELL REFERENCE TEMPERATURE, TREFLC(n)

Temperature change has two significant effects on the load cell's calibration. The first is that changes in temperature will cause resistance changes in the strain gage leads; the second is that the modulus of elasticity of steel drops as temperature increases. If the load cell is heated uniformly, the gages should not be affected by thermal expansion.

The best way to account for these effects is to perform force calibrations at several temperatures to determine their influence. Appendix C describes how to calculate temperature correction coefficients, CCLDTC(n), when load cell calibrations are available that have been conducted at different temperatures. In the event that this information is not available and temperature corrections are desired, a value of

$$CCLDTC(n) = -0.0002500$$

may be used instead. This coefficient only accounts for changes in the modulus of elasticity for load cells made of 17-4 pH stainless steel. It is derived from engineering handbook specifications and is also included in appendix C.

The reference temperature, TREFLC(n), is the temperature at which the load cell was calibrated in degrees fahrenheit. For the case where CCLDTC(n) was calculated

from multiple calibrations, TREFLC(n) is the datum temperature used in the calculations.

## TARES, PITCH TARES, AND PITCH TARE DATA FILES

### PTAR.DAT and TCOF\*\*.DAT

Pitch tares serve the same function for the load cell balance system as the "static" used with the 40 by 80 Wind Tunnel balance system. They are a set of tares that can be subtracted from the data to account for shifts in the model's weight vector relative to the balance system after the zeros are taken.

Pitch tares are taken during a tare run. The procedure is the same as it is for a normal data run; zeros and rcal points are taken when the model is in the reference position (PTZ and PTC). No external forces are applied to the model as data are recorded with the PTR command. The data set from a tare point (tare frame) are a measure of the change in the load cell force readings when the model or parts of the model are changed to positions other than the reference position that they occupy during a zero point.

The tares are sorted by ascending alpha (pitch angle) and stored in the file TCOF\*\*.DAT which can be accessed later to change individual tare values. The \*\* represents the run number during which the tares were taken. It is possible to make several different tare runs for different model configurations.

When NTAR is set equal to a tare file number, then the tares corresponding to a given alpha in the file will be subtracted from any data with the same alpha. If data are being taken at an alpha for which no tare exists, then a straight line interpolation will be made between the two adjacent tares and that value subtracted. It should be noted that because of the typically nonlinear nature of the tares that the interpolated values will generally be poor.

Tares are also subtracted from the preload values to make a first order correction of the interactions that are due to changes in model pitch.

TABLE 1.- LOAD CELL NUMBERING

Load cell	1	2	3	4
Configuration				
Tail strut aft	Left main	Right main	Tail strut	
Tail strut forward	Tail strut	Left main	Right main	
Four load cells	Left front	Right front	Left rear	Right rear

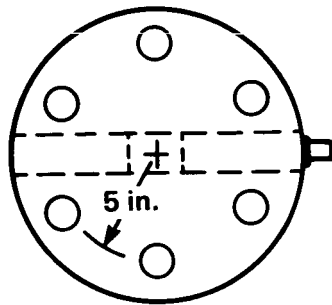

STANDARD 40 BY 80 ATTACHMENT  
PAD 5 in. BOLT CIRCLE

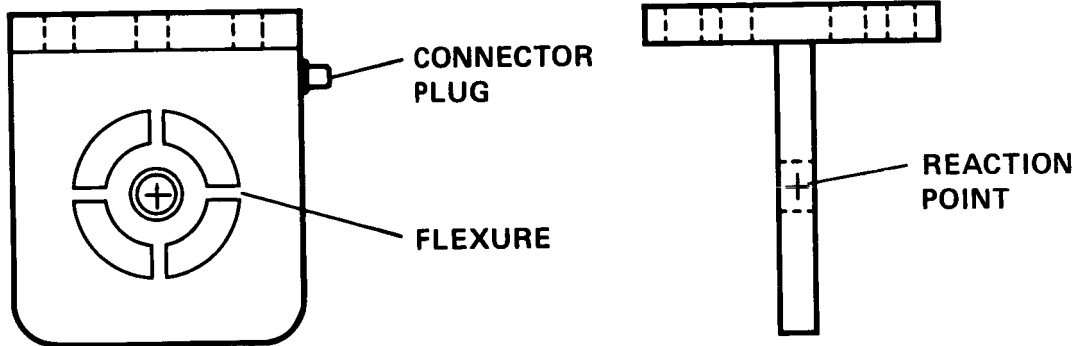

(a) Three-component load cell.

Figure 1.- Three-axis load cell installation.

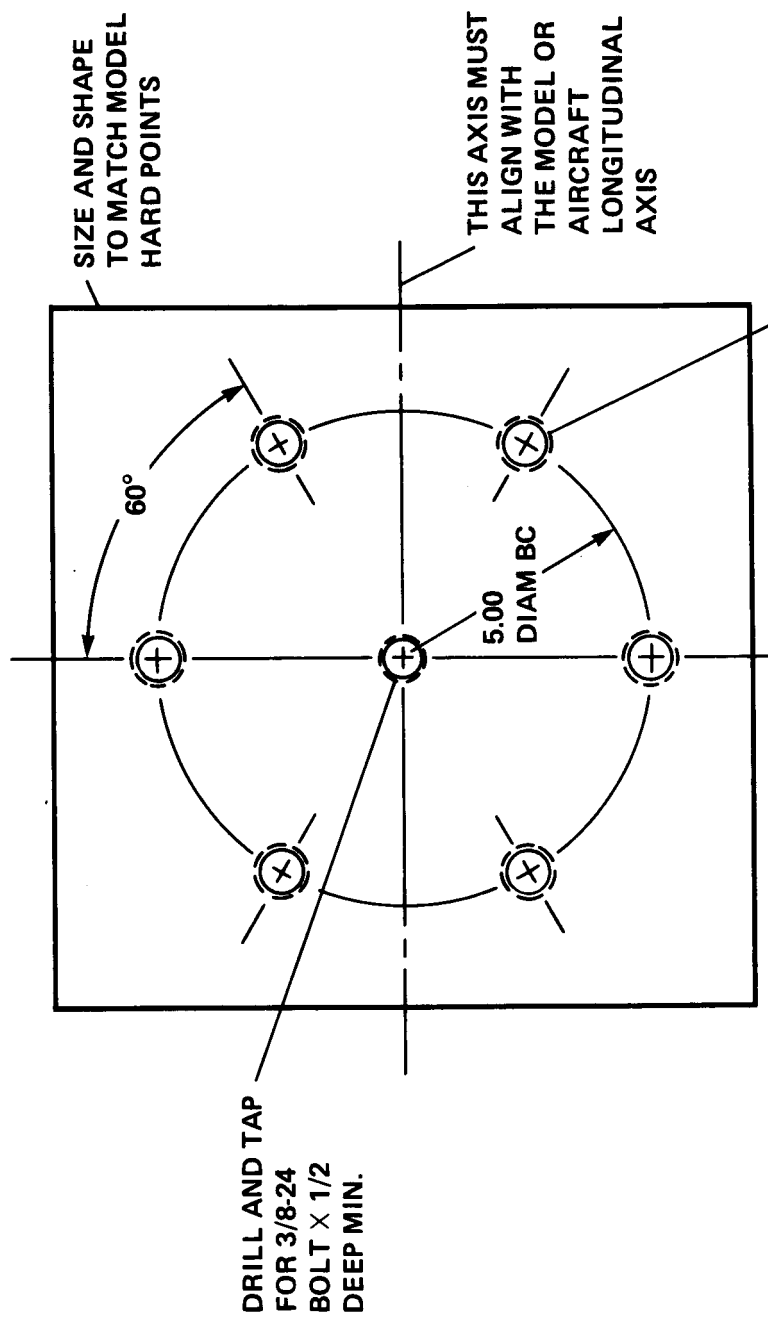
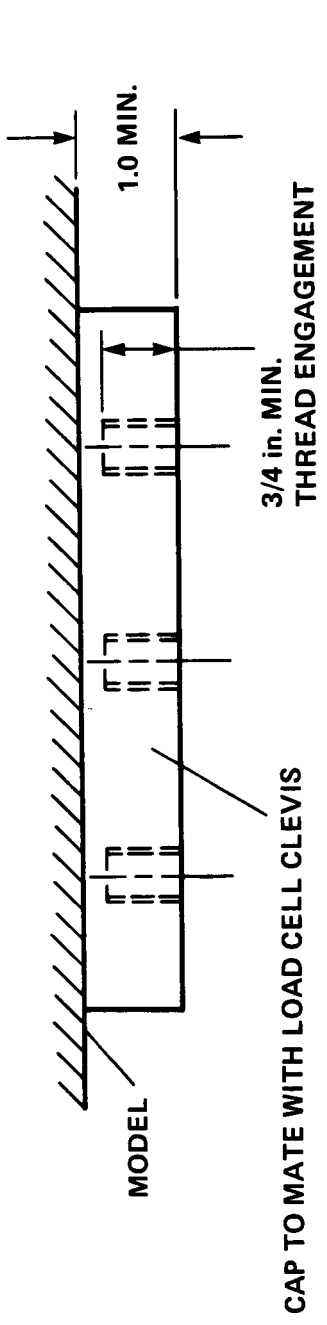

NOTE: 1. CAP (MADE BY USER)  
 MATERIAL: 4130, 4340 STEEL  
 (DO NOT USE MILD STEEL)  
 2. ALL DIMENSIONS IN inches

DRILL AND TAP FOR 7/16-20 BOLT 6 PLCS.  
 DRILL AND TAP BY NASA-Ames

(b) Model attachment pads between model hard points and load cells.

Figure 1.- Continued.



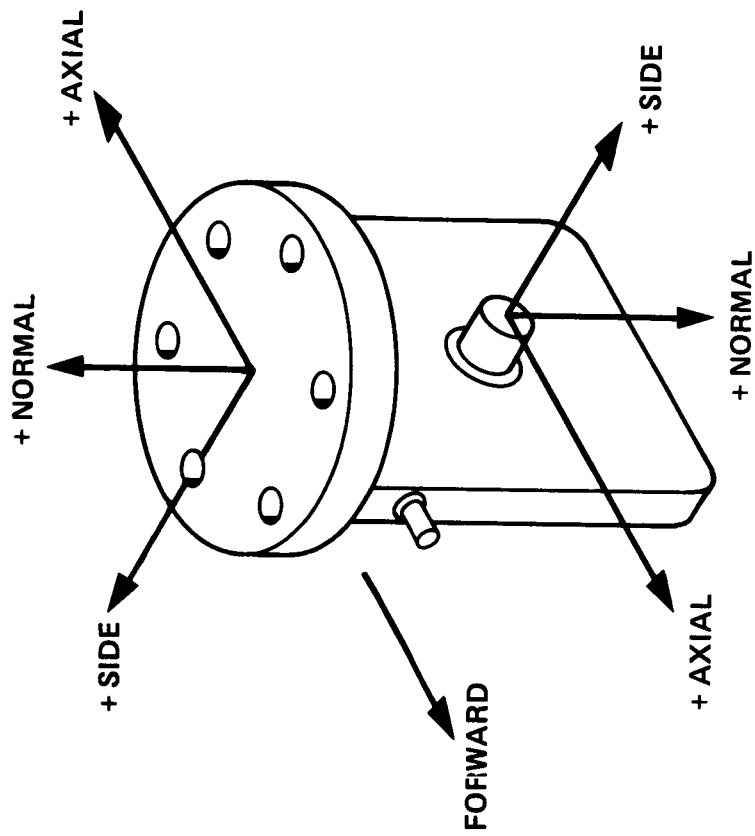

(c) Sign convention assumed for positive loading of load cell or pin forces.

Figure 1.- Concluded.

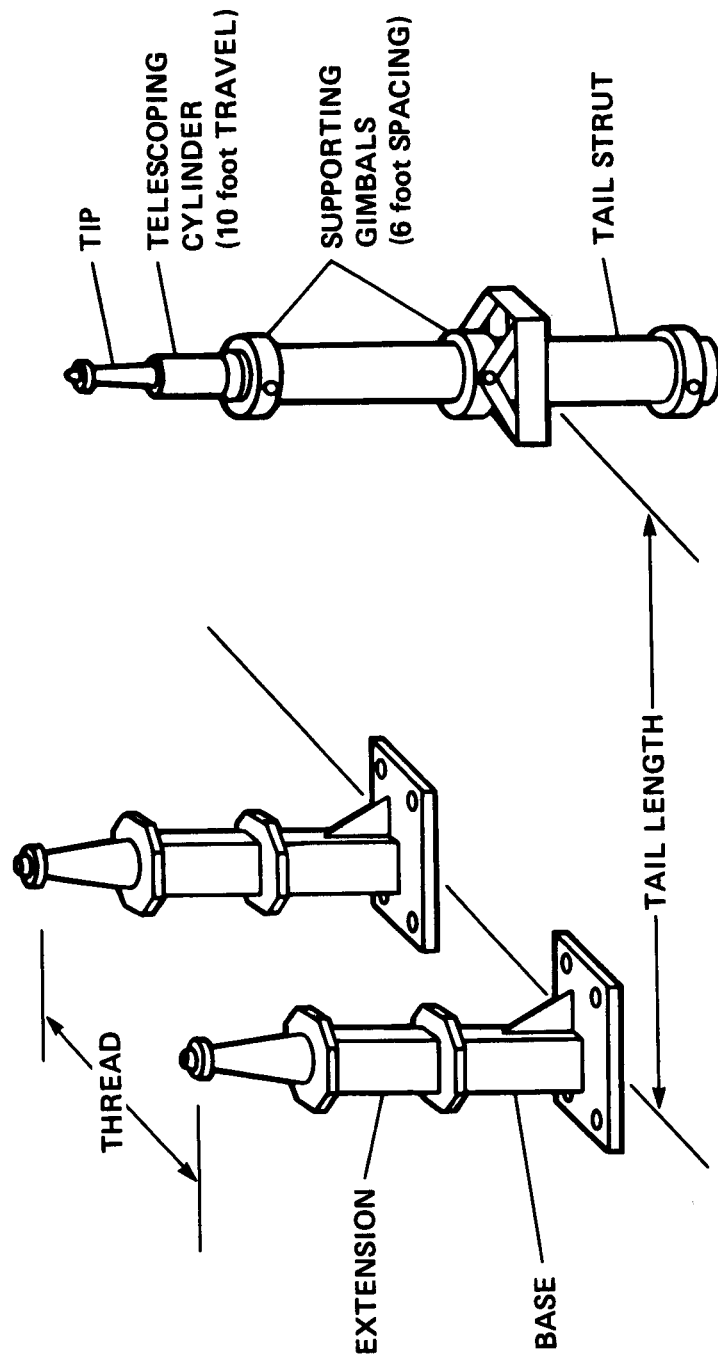

**MAIN STRUTS  
ASSEMBLIES MUST INCLUDE  
AT LEAST ONE BASE AND ONE TIP  
PER STRUT**

Figure 2.- Typical model support strut installation.

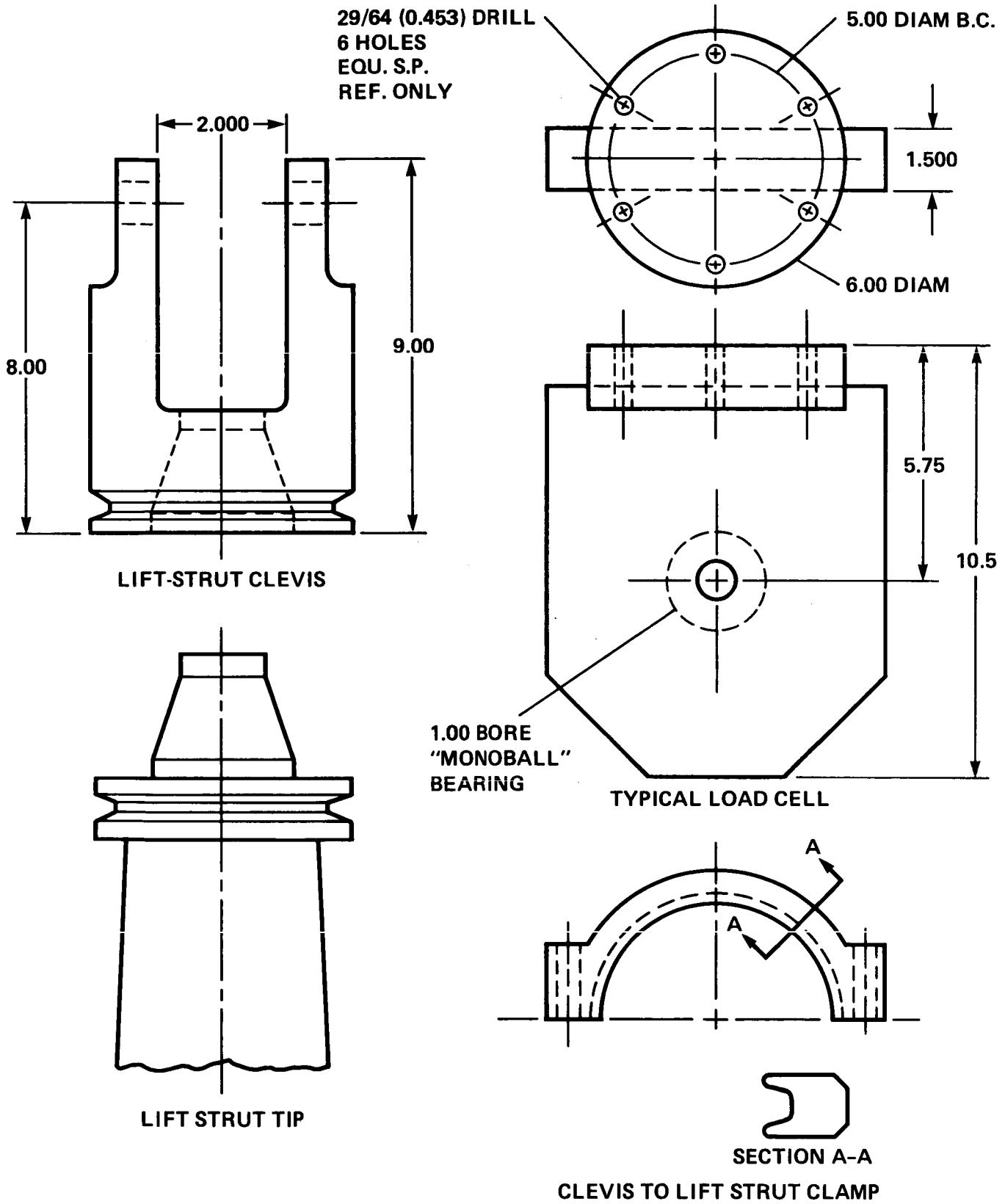
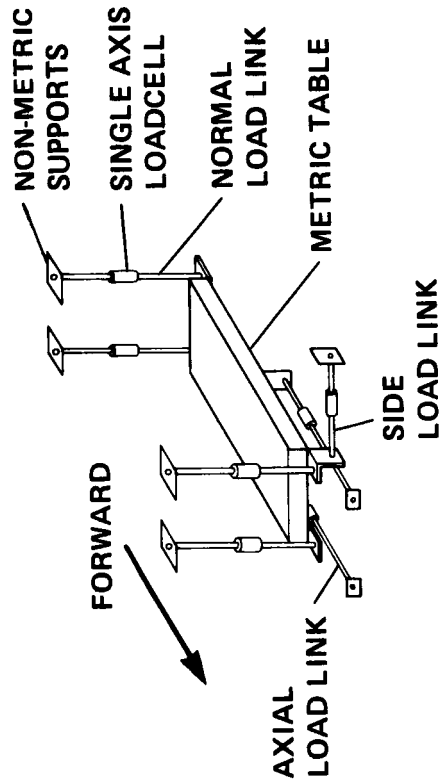
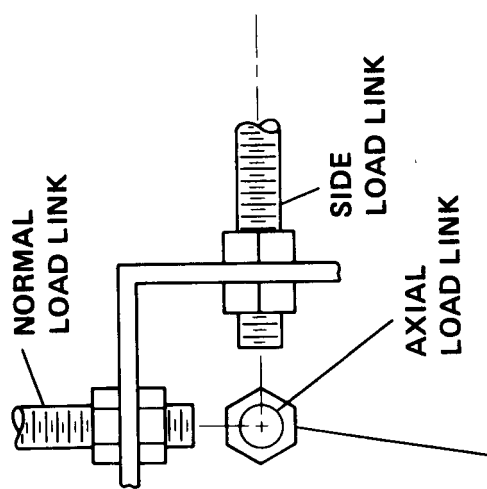

Figure 3.- Typical strut to model mounting hardware.



AS SHOWN CO-PLANNER LINKS ARE:

- SIDE AND AXIALS
- SIDE AND FRONT NORMALS
- LEFT AXIAL AND LEFT NORMALS
- RIGHT AXIAL AND RIGHT NORMALS
- REAR NORMALS



REACTION POINT OF THE PSEUDO  
LOADCELL IS AT THE INTERSECTION  
OF THE AXES OF THE THREE LINKS

Figure 4.- Jet propulsion test stand.

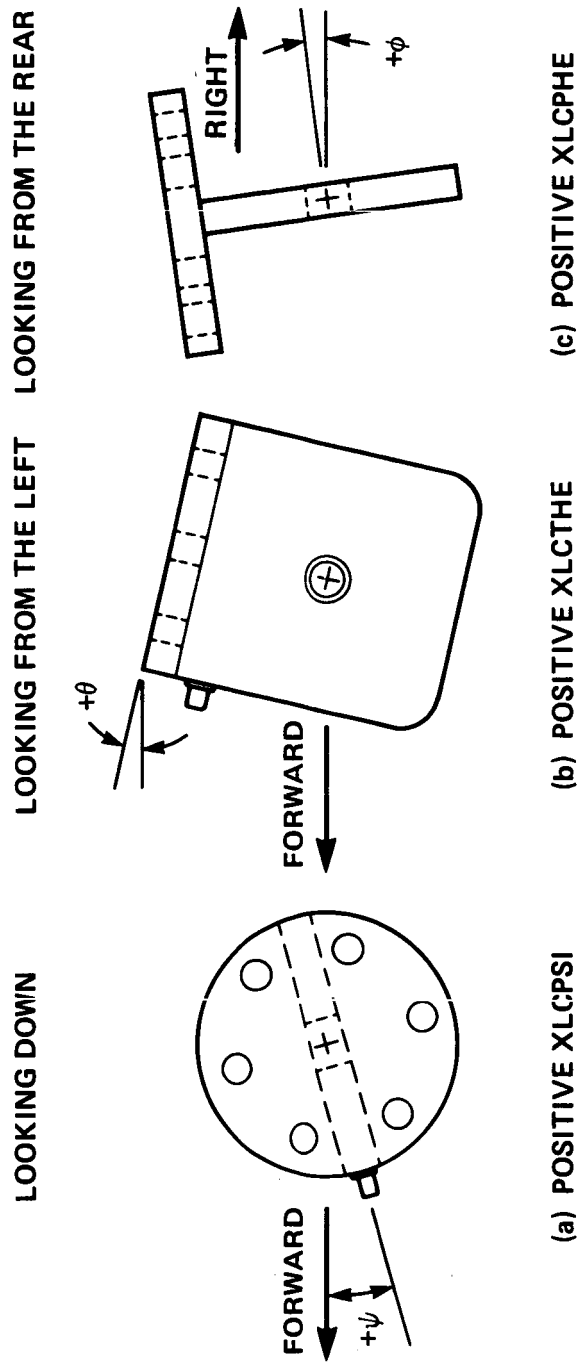

Figure 5.- Load cell positive angle orientation.

APPENDIX A

SAMPLE CALIBRATION REPORT FOR LOAD CELL S.N. 486

(NORMAL FORCE GAGE ONLY)

**NASA - AMES RESEARCH CENTER**  
**MOFFETT FIELD, CALIFORNIA 94035**

**CALIBRATION REPORT**

PAGE \_\_\_ OF \_\_\_

CALIBRATION AGENCY <b>D O A</b>			Ames Property Tag Number		
<b>INSTRUMENT IDENTIFICATION</b>			Calibration Report Number <b>4646</b>		
			Previous Service Date	Calibration Date <b>8-17-82</b>	
Manufacturers Name <b>11ASA</b>	Model Number <b>N/A</b>	Serial Number <b>4867</b>	Calibration Interval <b>1 yr.</b>	Next Calibration Due <b>8-17-83</b>	
Instrument Description <b>Load cell</b>			Contract Number		
CALIBRATION DATA / REMARKS			REASON FOR SUBMISSION		
<b>See attached data</b>			<input type="checkbox"/> New Instrument <input checked="" type="checkbox"/> Calibration <input type="checkbox"/> Repair <input type="checkbox"/> Other		
			INSTRUMENT INDICATES		
			<input checked="" type="checkbox"/> Good Condition <input type="checkbox"/> Age and Long Service <input type="checkbox"/> Mishandling <input type="checkbox"/> Overload <input type="checkbox"/> Severe Environment		
			THIS INSTRUMENT FOUND TO BE		
STANDARDS USED			<input type="checkbox"/> Within Tolerance <input type="checkbox"/> Out of Tolerance		
Instrument	Manufacturer	Model No.	Serial No.	Calibration Date	
<b>DVM</b>	<b>HP</b>	<b>3455A</b>	<b>1623A 02247</b>	<b>8-19-81</b>	
<b>Force System</b>	<b>Morehouse</b>	<b>NASA 28206</b>	<b>M3134</b>	<b>5-10-82</b>	
INSPECTION DATA			LABOR		
CALIBRATION PER <b>A-387</b>	TEMP. C°	HUMIDITY %	TECHNICIAN <b>CW</b>		
REPLACEMENT PARTS					
DESCRIPTION	CIRCUIT LOCATION	MODEL NO.	QUANTITY	UNIT PRICE	EXTENSION

NOTE: USE ARC 101A "CALIBRATION REPORT SUPPLEMENT" FOR RECORDING ADDITIONAL INFORMATION.

YES  THIS CALIBRATION WAS PERFORMED WITH "STANDARDS" TRACEABLE TO THE NATIONAL BUREAU OF STANDARDS. *A Mendel*  
 NO  LABORATORY SUPERVISOR

DISTRIBUTION:

CONTRACT MONITOR'S COPY -- (WHITE) CALIBRATION FACILITY COPY -- (YELLOW) REQUESTOR'S COPY -- (PINK)  
 ARC 101 (Rev. Jun 75)

Figure A1.- Calibration report form.

LOAD CELL CALIBRATION  
S/N: 4867  
EXCITATION: 10 VDC

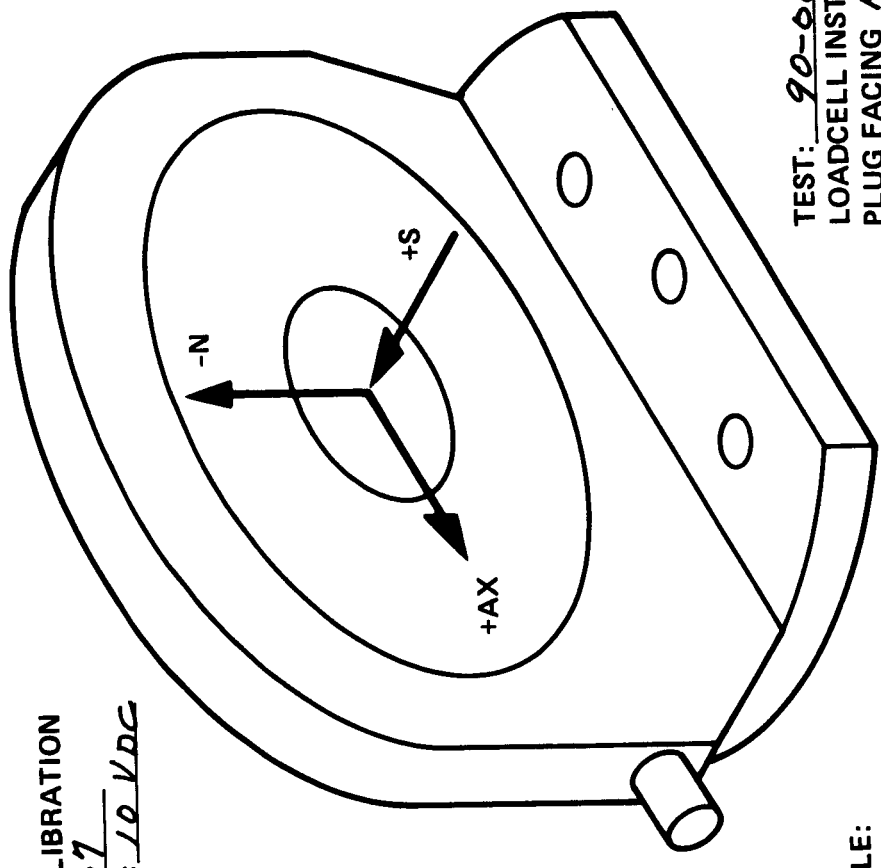

LOAD SCHEDULE:  
NORMAL LOAD: ± 18,000 lb  
AXIAL LOAD: ± 6,000 lb  
SIDE LOAD: ± 2,000 lb

TEST: 90-008  
LOADCELL INSTALLATION:  
PLUG FACING FORWARD  
POSITIVE LOAD DEFINED BY  
LAB AND CELLS OPPOSITE  
FOR THE FOLLOWING  
GAGE(S) NORMAL

Figure A2.- Loadcell orientation calibration.



LOAD CELL CALIBRATION  
 NORMAL GAGE UNDER POSITIVE TENSION  
 SERIAL # :4867  
 MNEMONICS:NORMAL GAGE  
 TARE WEIGHT : 0 lbs  
 AVE. ROOM TEMP. : 0 DEG. F  
 FULL-SCALE LOAD : 18000 lbs

T.O. :A-387  
 DATE :8-17-82

RUN #	O/P V V	V1	EXCIT.V2 V	(V1-Vo)/V2 V/V	STD LOAD lbs	CALC. LOAD lbs	DEV. lbs	ACCU. %(F.S.)
1	.000019		10.04068	0.0000000	0.00	-5.33	-5.33	-.030
2	.001755		10.04071	.0001729	1999.83	1997.32	-2.51	-.014
3	.003488		10.04072	.0003455	3989.66	3996.51	6.85	.038
4	.005221		10.04070	.0005181	5981.46	5995.72	14.26	.079
5	.006940		10.04069	.0006893	7963.53	7978.77	15.24	.085
6	.008657		10.04073	.0008603	9947.47	9959.47	12.00	.067
7	.010367		10.04076	.0010306	11925.88	11932.09	6.21	.035
8	.012076		10.04073	.0012008	13901.59	13903.63	2.04	.011
9	.013770		10.04073	.0013695	15864.67	15857.83	-6.84	-.038
10	.015612		10.04073	.0015530	17989.07	17982.77	-6.30	-.035
11	.013763		10.04070	.0013688	15855.24	15849.80	-5.44	-.030
12	.012060		10.04066	.0011992	13887.62	13885.27	-2.35	-.013
13	.010355		10.04064	.0010294	11920.62	11918.39	-2.23	-.012
14	.008639		10.04065	.0008585	9938.33	9938.79	.46	.003
15	.006921		10.04064	.0006874	7961.08	7956.89	-4.19	-.023
16	.005199		10.04063	.0005159	5974.32	5970.38	-3.94	-.022
17	.003474		10.04062	.0003441	3985.53	3980.40	-5.13	-.028
18	.001753		10.04063	.0001727	2000.44	1995.03	-5.41	-.030
19	.000017		10.04066	-.0000002	-.24	-7.64	-7.40	-.041

BEST FIT STRAIGHT LINE EQUATION :  $Y=A(0)+A(1)*X$

Y-INTERCEPT = A(0) = -5.33329792569 lbs

SLOPE = A(1) = 11582995.1707 lbs/(V/V)

STANDARD DEVIATION = 7.16 lbs

MAXIMUM DEVIATION = 15.24 lbs

CORRELATION COEFF. = .99999828

Figure A3.- Loadcell calibration report.

LOAD CELL CALIBRATION  
 NORMAL GAGE UNDER POSITIVE TENSION  
 SERIAL # :4867  
 MNEMONICS:NORMAL GAGE  
 TARE WEIGHT : 0 lbs  
 AVE. ROOM TEMP. : 0 DEG. F  
 FULL-SCALE LOAD : 18000 lbs

T.O. :A-387  
 DATE :8-17-82

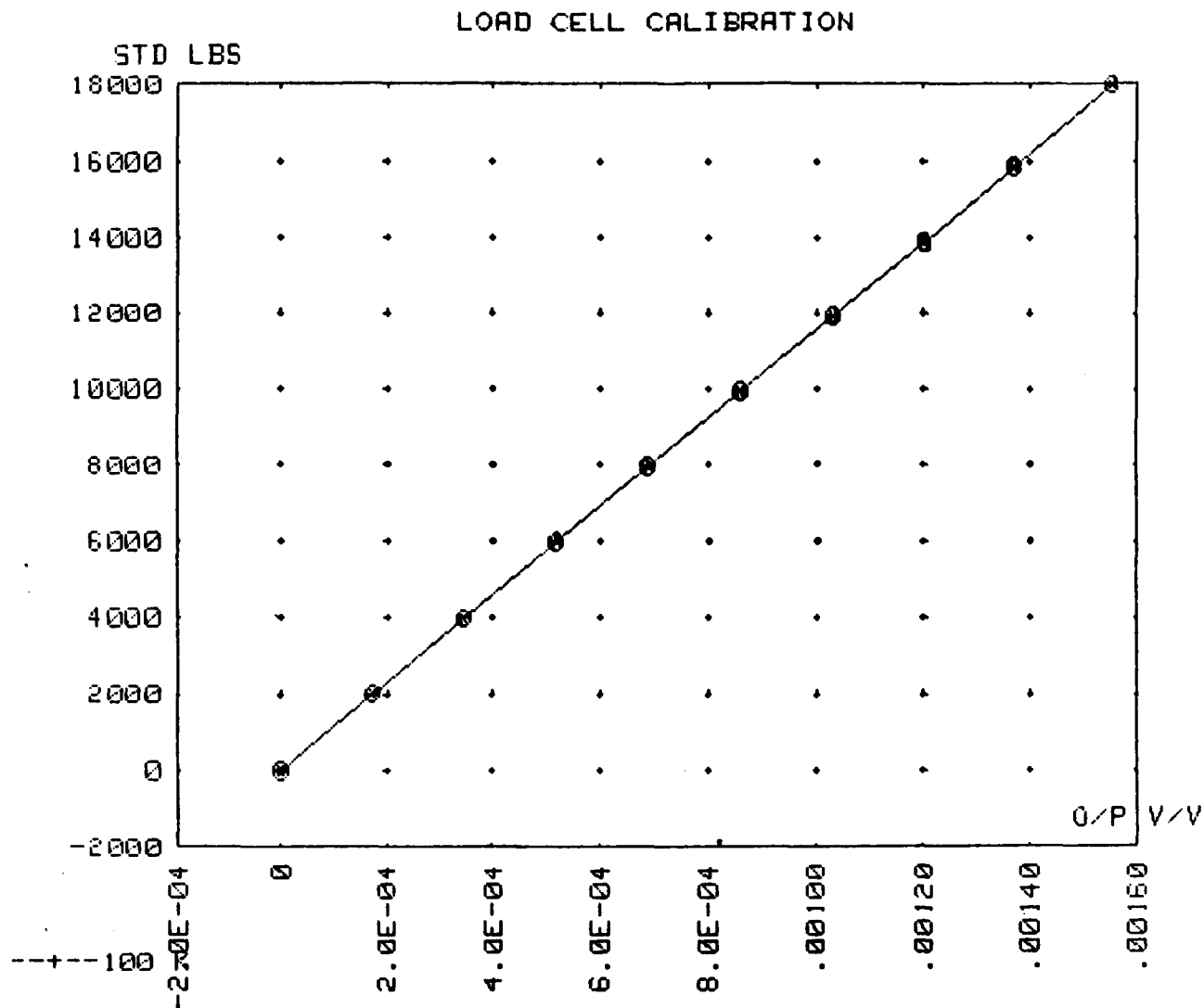

\* SIGN INDICATES FIRST HALF OF THE LOADING CYCLE

RESISTOR = 100 K OHMS

RCAL	= -.000434	V/V
------	------------	-----

NO LOAD V/V	RCAL V/V
.000003	-.000431

SIG PWR
- +

Figure A3.- Continued.

ORIGINAL PAGE IS  
OF POOR QUALITY

LOAD CELL CALIBRATION  
NORMAL GAGE UNDER NEGATIVE TENSION  
SERIAL # :4867  
MHEMONICS:NORMAL GAGE  
TARE WEIGHT : 0 lbs  
AVE. ROOM TEMP. : 0 DEG. F  
FULL-SCALE LOAD : 18000 lbs

T.O. :A-387  
DATE :8-17-82

RUN #	O/P V	V1	EXCIT.V2 V	(V1-Vo)/V2 V/V	STD LOAD lbs	CALC. LOAD lbs	DEV. lbs	ACCU. %(F.S.)
1	.000042	10.04072	10.04072	0.0000000	0.00	-4.88	-4.88	-.027
2	-.001707	10.04073	10.04073	-.0001742	-2002.79	-2008.25	-5.46	-.030
3	-.003441	10.04076	10.04076	-.0003469	-3991.32	-3994.44	-3.12	-.017
4	-.005177	10.04078	10.04078	-.0005198	-5981.71	-5982.90	-1.19	-.007
5	-.006909	10.04077	10.04077	-.0006923	-7971.10	-7966.80	4.30	.024
6	-.008637	10.04078	10.04078	-.0008644	-9951.86	-9946.10	5.76	.032
7	-.010363	10.04073	10.04073	-.0010363	-11927.55	-11923.18	4.37	.024
8	-.012084	10.04074	10.04074	-.0012077	-13896.23	-13894.47	1.76	.010
9	-.013807	10.04074	10.04074	-.0013793	-15865.19	-15868.06	-2.87	-.016
10	-.015658	10.04078	10.04078	-.0015636	-17973.27	-17988.20	-14.93	-.083
11	-.013805	10.04072	10.04072	-.0013791	-15857.21	-15865.80	-8.59	-.048
12	-.012077	10.04072	10.04072	-.0012070	-13886.80	-13866.48	.32	.002
13	-.010353	10.04075	10.04075	-.0010353	-11918.21	-11911.70	6.51	.036
14	-.008625	10.04070	10.04070	-.0008632	-9943.10	-9932.44	10.66	.059
15	-.006892	10.04065	10.04065	-.0006906	-7958.50	-7947.42	11.08	.062
16	-.005166	10.04069	10.04069	-.0005187	-5976.16	-5970.35	5.81	.032
17	-.003434	10.04066	10.04066	-.0003462	-3988.78	-3986.46	2.32	.013
18	-.001701	10.04066	10.04066	-.0001736	-1997.56	-2001.40	-3.84	-.021
19	.000042	10.04068	10.04068	0.0000000	3.12	-4.88	-8.00	-.044

BEST FIT STRAIGHT LINE EQUATION :  $Y=A(0)+A(1)*X$

Y-INTERCEPT =  $A(0)$  = -4.88004019483 lbs

SLOPE =  $A(1)$  = 11501052.7026 lbs/(V/V)

STANDARD DEVIATION = 6.65 lbs

MAXIMUM DEVIATION = 14.93 lbs

CORRELATION COEFF. = .99999852

Figure A3.- Continued.

LOAD CELL CALIBRATION  
 NORMAL GAGE UNDER NEGATIVE TENSION  
 SERIAL # : 4867  
 MNEMONICS: NORMAL GAGE  
 TARE WEIGHT : 0 lbs  
 AVE. ROOM TEMP. : 0 DEG. F  
 FULL-SCALE LOAD : 18000 lbs

T.O. : A-387  
 DATE : 8-17-82

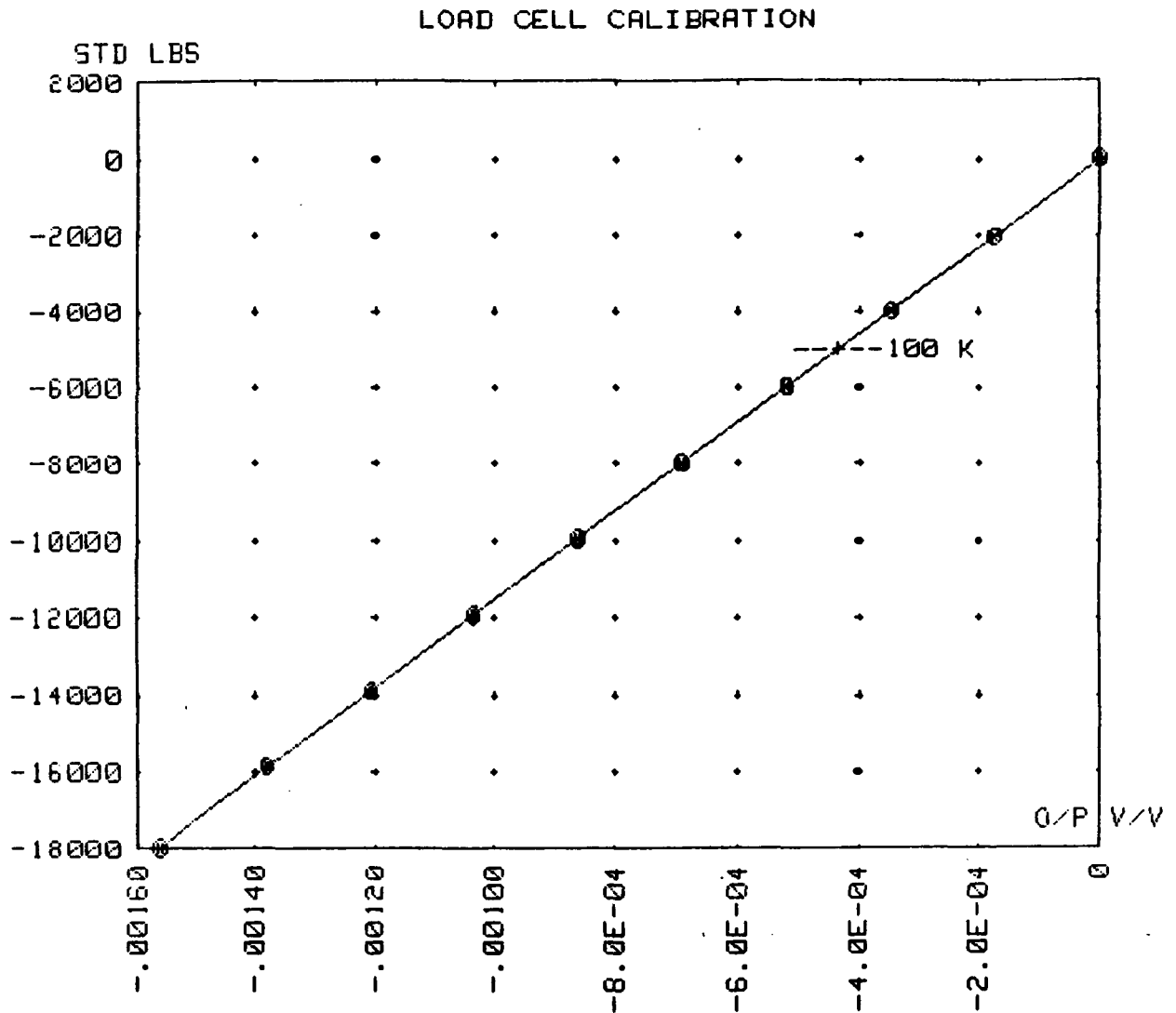

\* SIGN INDICATES FIRST HALF OF THE LOADING CYCLE

RESISTOR = 100 K OHMS

RCAL = -.000434 V/V

NO LOAD V/V  
 .000003

RCAL V/V  
 -.000431

SIG PWR  
 - +

Figure A3.- Continued.

INTERACTION  
 NORMAL GAGE UNDER POSITIVE TENSION  
 SERIAL # :4867  
 MNEMONICS:AXIAL GAGE  
 TARE WEIGHT : 0 lbs  
 AVE. ROOM TEMP. : 0 DEG. F  
 FULL-SCALE LOAD : 6000 lbs

T.O. :A-387  
 DATE :8-17-82

RUN #	O/P V1 V	EXCIT.V2 V	(V1-Vo)/V2 V/V-->lbs	STD LOAD lbs	CALC. LOAD lbs	DEV. lbs	ACCU. %(F.S.)
1	-.000017	10.03750	0.00	0.00	-.40	-.40	-.007
2	-.000022	10.03752	-3.08	1999.83	-.93	2.15	.036
3	-.000023	10.03752	-3.70	3989.66	-1.46	2.24	.037
4	-.000020	10.03751	-1.85	5981.46	-2.00	-.15	-.002
5	-.000020	10.03748	-1.85	7963.53	-2.52	-.67	-.011
6	-.000019	10.03755	-1.23	9947.47	-3.05	-1.82	-.030
7	-.000021	10.03757	-2.47	11925.88	-3.58	-1.11	-.019
8	-.000022	10.03753	-3.08	13901.59	-4.11	-1.02	-.017
9	-.000025	10.03754	-4.93	15864.67	-4.63	.30	.005
10	-.000027	10.03754	-6.17	17989.07	-5.20	.97	.016
11	-.000027	10.03751	-6.17	15855.24	-4.63	1.54	.026
12	-.000025	10.03745	-4.93	13887.62	-4.10	.83	.014
13	-.000023	10.03743	-3.70	11920.62	-3.58	.12	.002
14	-.000021	10.03745	-2.47	9938.33	-3.05	-.58	-.010
15	-.000020	10.03744	-1.85	7961.08	-2.52	-.67	-.011
16	-.000018	10.03743	-.62	5974.32	-1.99	-1.38	-.023
17	-.000019	10.03743	-1.23	3985.53	-1.46	-.23	-.004
18	-.000018	10.03744	-.62	2000.44	-.93	-.32	-.005
19	-.000018	10.03747	-.62	-.24	-.40	.22	.004

BEST FIT STRAIGHT LINE EQUATION :  $Y=A(0)+A(1)*X$   
 Y-INTERCEPT = A(0) = -.40095693028 lbs  
 SLOPE = A(1) = -2.66619280420E-04 (lbs)/(lbs)

STANDARD DEVIATION = 1.10 lbs  
 MAXIMUM DEVIATION = 2.24 lbs  
 CORRELATION COEFF. = .63831363 V/V CONVERTED TO LBS BY USING 1ST-DEG SLOPE

Figure A3.- Continued.

INTERACTION  
 NORMAL GAGE UNDER POSITIVE TENSION  
 SERIAL # : 4867  
 MNEMONICS: AXIAL GAGE  
 TARE WEIGHT : 0 lbs  
 AVE. ROOM TEMP. : 0 DEG. F  
 FULL-SCALE LOAD : 6000 lbs

T.O. : A-367  
 DATE : 8-17-82

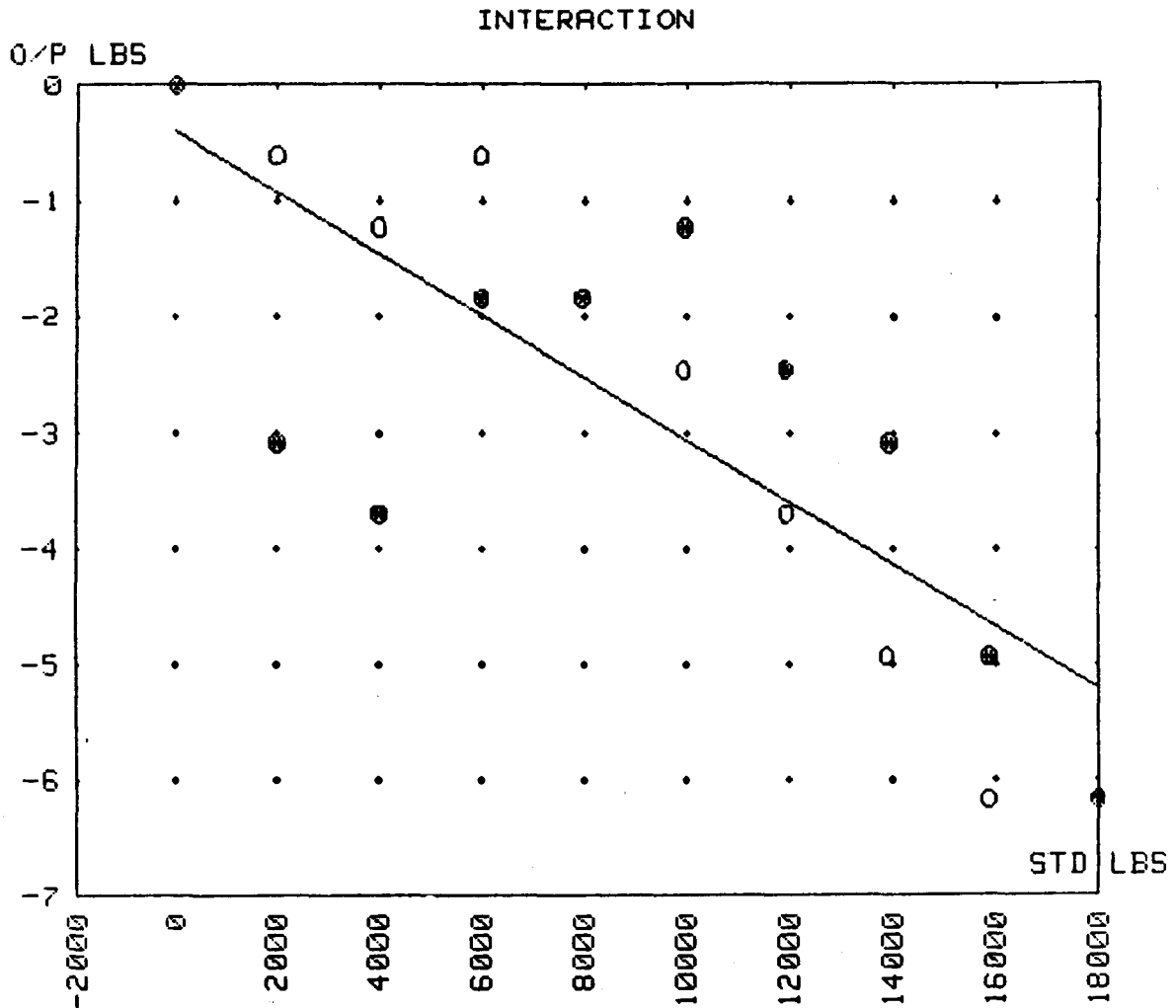

\* SIGN INDICATES FIRST HALF OF THE LOADING CYCLE

RESISTOR = 100 K OHMS

RCAL = .000873 V/V

NO LOAD V/V  
-.000002

RCAL V/V  
.000871

SIG PWR  
- -

Figure A3.- Continued.

INTERACTION  
 NORMAL GAGE UNDER NEGATIVE TENSION  
 SERIAL # : 4867  
 MNEMONICS: AXIAL GAGE  
 TARE WEIGHT : 0 lbs  
 AVE. ROOM TEMP. : 0 DEG. F  
 FULL-SCALE LOAD : 6000 lbs

T.O. : A-387  
 DATE : 8-17-82

RUN #	O/P V	V1	EXCIT. V2	(V1-Vo)/V2	STD LOAD	CALC. LOAD	DEV.	ACCU.
			V	V/V-->lbs	lbs	lbs	lbs	%(F.S.)
1	-.000015		10.03755	0.00	0.00	3.35	3.35	.056
2	-.000015		10.03755	0.00	-2002.79	-.25	-.25	-.004
3	-.000017		10.03757	-1.23	-3991.32	-3.82	-2.58	-.043
4	-.000020		10.03761	-3.08	-5981.71	-7.39	-4.31	-.072
5	-.000028		10.03758	-8.02	-7971.10	-10.97	-2.95	-.049
6	-.000035		10.03759	-12.33	-9951.86	-14.53	-2.19	-.037
7	-.000040		10.03753	-15.42	-11927.55	-18.08	-2.66	-.044
8	-.000047		10.03753	-19.73	-13896.23	-21.61	-1.88	-.031
9	-.000054		10.03755	-24.05	-15865.19	-25.15	-1.10	-.018
10	-.000063		10.03759	-29.60	-17973.27	-28.94	.66	.011
11	-.000060		10.03752	-27.75	-15857.21	-25.14	2.61	.044
12	-.000056		10.03755	-25.28	-13886.80	-21.60	3.69	.061
13	-.000049		10.03756	-20.97	-11918.21	-18.06	2.91	.048
14	-.000041		10.03751	-16.03	-9943.10	-14.51	1.52	.025
15	-.000034		10.03747	-11.72	-7958.50	-10.95	.77	.013
16	-.000026		10.03748	-6.78	-5976.16	-7.38	-.60	-.010
17	-.000021		10.03748	-3.70	-3988.78	-3.81	-.11	-.002
18	-.000016		10.03746	-.62	-1997.56	-.24	.38	.006
19	-.000014		10.03750	.62	3.12	3.36	2.74	.046

BEST FIT STRAIGHT LINE EQUATION :  $Y=A(0)+A(1)*X$   
 Y-INTERCEPT = A(0) = 3.3520827095 lbs  
 SLOPE = A(1) = 1.79650117858E-03 (lbs)/(lbs)

STANDARD DEVIATION = 2.32 lbs  
 MAXIMUM DEVIATION = 4.31 lbs  
 CORRELATION COEFF. = .94711410 V/V CONVERTED TO LBS BY USING 1ST-DEG SLOPE

Figure A3.- Continued.

INTERACTION  
 NORMAL GAGE UNDER NEGATIVE TENSION  
 SERIAL # :4867  
 MNEMONICS:AXIAL GAGE  
 TARE WEIGHT : 0 lbs  
 AVE. ROOM TEMP. : 0 DEG. F  
 FULL-SCALE LOAD : 6000 lbs

T.O. :A-387  
 DATE :8-17-82

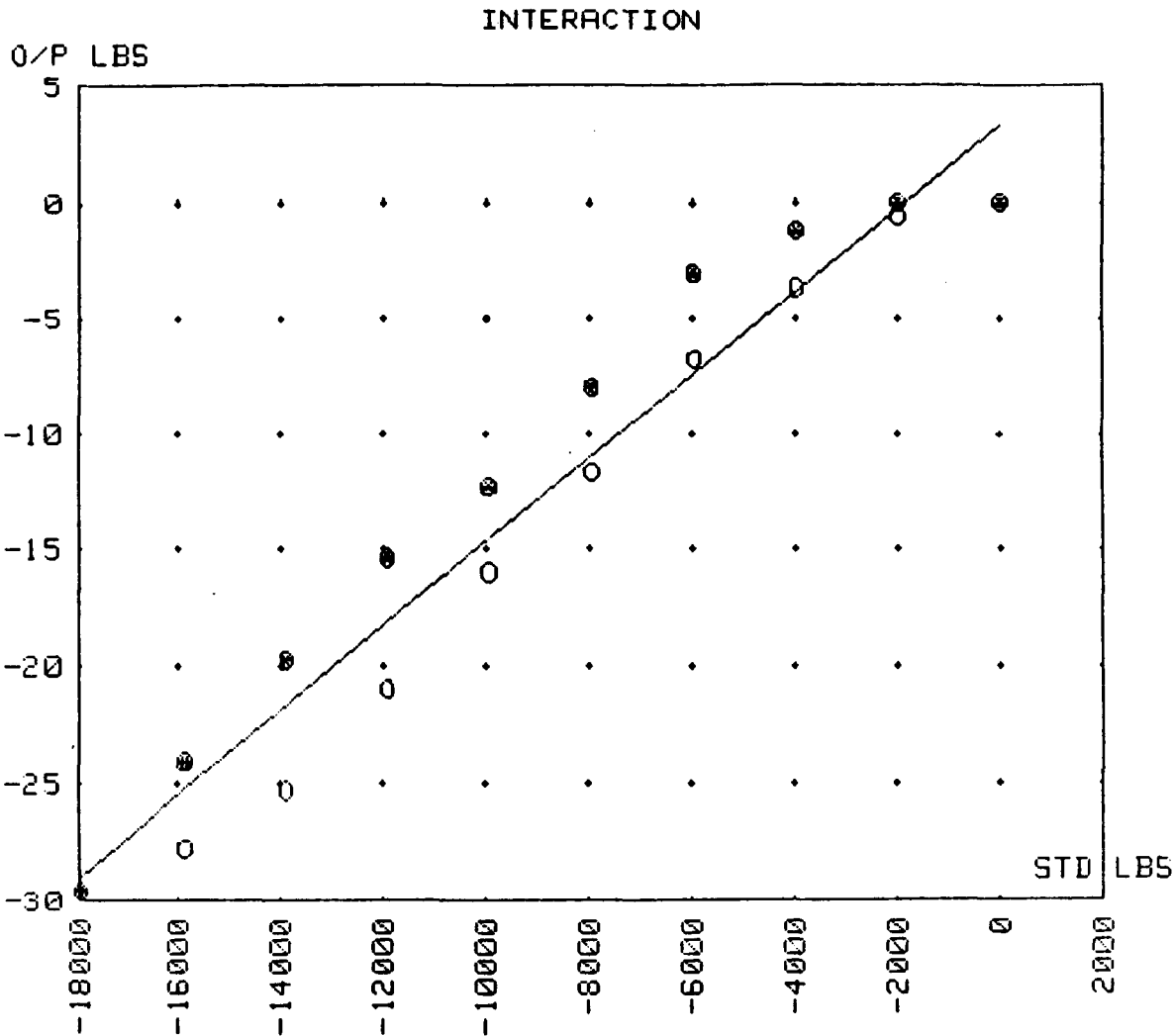

\* SIGN INDICATES FIRST HALF OF THE LOADING CYCLE

RESISTOR = 100 K OHMS

RCAL = .000873 V/V

NO LOAD V/V  
-.000002

RCAL V/V  
.000871

SIG PWR  
- -

Figure A3.- Continued.



INTERACTION  
 NORMAL GAGE UNDER POSITIVE TENSION  
 SERIAL # :4867  
 MNEMONICS:SIDE GAGE  
 TARE WEIGHT : 0 lbs  
 AVE. ROOM TEMP. : 0 DEG. F  
 FULL-SCALE LOAD : 2000 lbs

T.O. :A-387  
 DATE :8-17-82

RUN #	O/P V	V1	EXCIT. V2	(V1-Vo)/V2	STD LOAD	CALC. LOAD	DEV.	ACCU.
	V		V	V/V-->lbs	lbs	lbs	lbs	%(F.S.)
1	.000081		10.03604	0.00	0.00	-29.07	-29.07	-1.453
2	-.000127		10.03605	-45.83	1999.83	20.30	66.13	3.306
3	.000216		10.03602	27.08	3989.66	69.42	42.34	2.117
4	.000690		10.03603	122.15	5981.46	118.59	-3.56	-.178
5	.000969		10.03600	178.10	7963.53	167.52	-10.59	-.529
6	.001201		10.03606	224.63	9947.47	216.49	-8.14	-.407
7	.001415		10.03610	267.55	11925.88	265.33	-2.23	-.111
8	.001617		10.03607	308.07	13901.59	314.10	6.03	.301
9	.001794		10.03608	343.57	15864.67	362.56	18.99	.949
10	.001967		10.03608	378.27	17989.07	415.00	36.73	1.837
11	.001849		10.03605	354.60	15855.24	362.32	7.72	.386
12	.001705		10.03598	325.72	13887.62	313.75	-11.97	-.598
13	.001537		10.03596	292.03	11920.62	265.20	-26.83	-1.342
14	.001339		10.03596	252.32	9938.33	216.26	-36.05	-1.803
15	.001119		10.03596	208.19	7961.08	167.46	-40.73	-2.037
16	.000870		10.03596	158.25	5974.32	118.41	-39.84	-1.992
17	.000350		10.03596	53.95	3985.53	69.32	15.36	.768
18	-.000029		10.03596	-24.24	2000.44	20.32	44.55	2.228
19	.000080		10.03597	-.22	-.24	-29.07	-28.85	-1.443

BEST FIT STRAIGHT LINE EQUATION : Y=A(0)+A(1)\*X

Y-INTERCEPT = A(0) = -29.066221642 lbs

SLOPE = A(1) = 2.46852796759E-02 (lbs)/(lbs)

STANDARD DEVIATION = 30.33 lbs

MAXIMUM DEVIATION = 66.13 lbs

CORRELATION COEFF. = .95187428

V/V CONVERTED TO LBS BY USING 1ST-DEG SLOPE

Figure A3.- Continued.

INTERACTION  
 NORMAL GAGE UNDER POSITIVE TENSION  
 SERIAL # : 4867  
 MNEMONICS: SIDE GAGE  
 TARE WEIGHT : 0 lbs  
 AVE. ROOM TEMP. : 0 DEG. F  
 FULL-SCALE LOAD : 2000 lbs

T.O. : A-387  
 DATE : 8-17-82

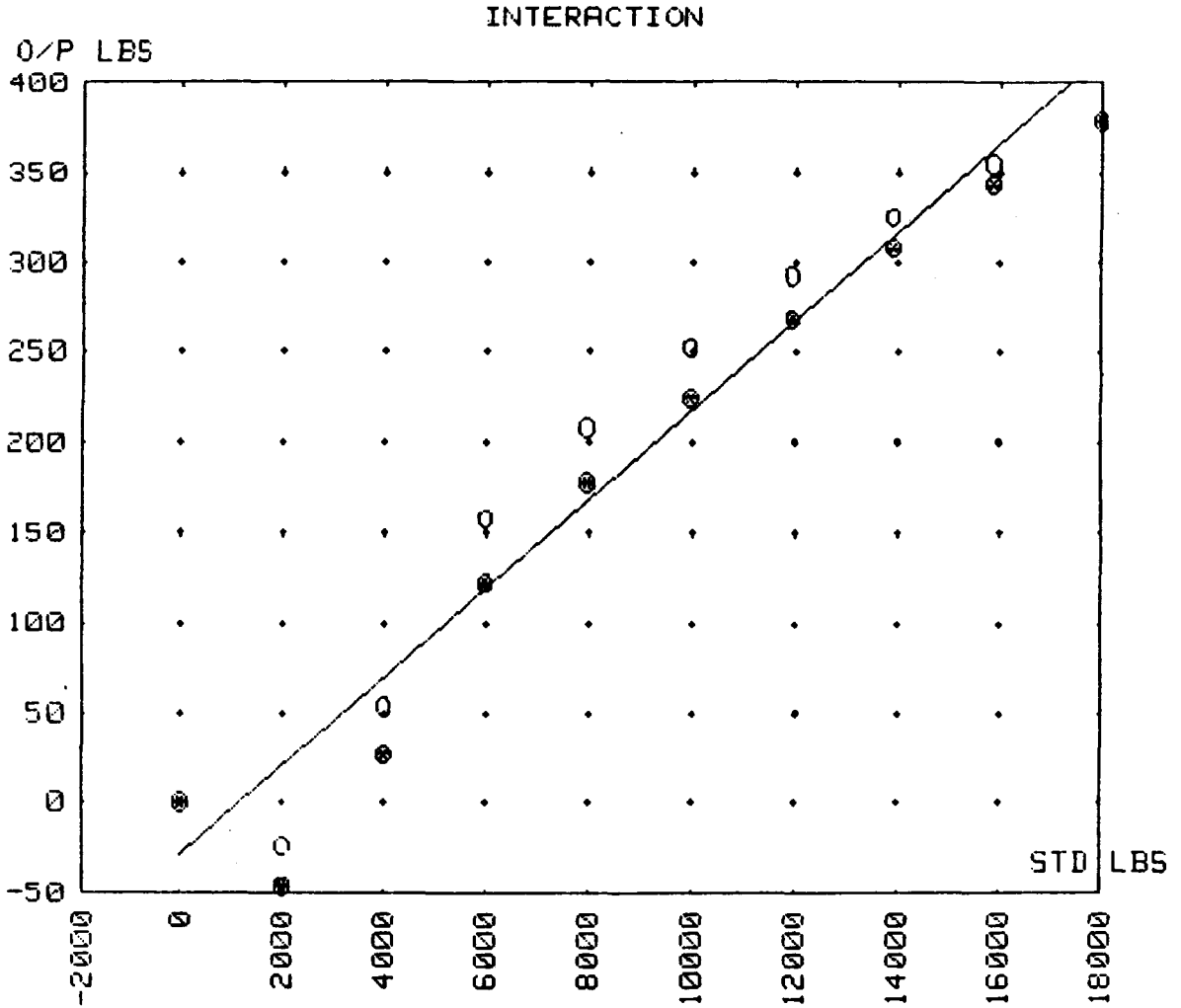

\* SIGN INDICATES FIRST HALF OF THE LOADING CYCLE

RESISTOR = 100 K OHMS

RCAL = .000435 V/V

NO LOAD V/V  
.000014

RCAL V/V  
.000449

SIG PWR  
- -

Figure A3.- Continued.

INTERACTION  
 NORMAL GAGE UNDER NEGATIVE TENSION  
 SERIAL # :4867  
 MNEMONICS:SIDE GAGE  
 TARE WEIGHT : 0 lbs  
 AVE. ROOM TEMP. : 0 DEG. F  
 FULL-SCALE LOAD : 2000 lbs

T.O. :A-387  
 DATE :8-17-82

RUN #	O/P V	V1	EXCIT. V2	(V1-V0)/V2	STD LOAD	CALC. LOAD	DEV.	ACCU.
			V	V/V-->lbs	lbs	lbs	lbs	%(F.S.)
1	.000075	10.03607		0.00	0.00	21.62	21.62	1.081
2	.000359	10.03607		56.96	-2002.79	79.38	22.42	1.121
3	.000809	10.03611		147.22	-3991.32	136.73	-10.48	-.524
4	.001213	10.03615		228.24	-5981.71	194.14	-34.10	-1.705
5	.001572	10.03612		300.25	-7971.10	251.52	-48.73	-2.436
6	.001880	10.03613		362.02	-9951.96	308.65	-53.37	-2.669
7	.002121	10.03606		410.36	-11927.55	365.63	-44.73	-2.237
8	.002300	10.03606		446.26	-13896.23	422.41	-23.85	-1.193
9	.002427	10.03608		471.73	-15865.19	479.20	7.47	.373
10	.002460	10.03612		478.35	-17973.27	540.00	61.65	3.083
11	.002285	10.03607		443.25	-15857.21	478.97	35.72	1.786
12	.002107	10.03607		407.55	-13886.80	422.14	14.59	.729
13	.001897	10.03608		365.43	-11918.21	365.36	-.07	-.004
14	.001653	10.03606		316.49	-9943.10	308.39	-8.10	-.405
15	.001369	10.03600		259.53	-7958.50	251.15	-8.38	-.419
16	.001044	10.03604		194.35	-5976.16	193.98	-.37	-.018
17	.000666	10.03603		118.54	-3988.78	136.66	18.12	.906
18	.000300	10.03601		45.13	-1997.56	79.23	34.10	1.705
19	.000100	10.03603		5.01	3.12	21.53	16.51	.826

BEST FIT STRAIGHT LINE EQUATION :  $Y=A(0)+A(1)*X$   
 Y-INTERCEPT = A(0) = 21.615815649 lbs  
 SLOPE = A(1) = -.028841871425 (lbs)/(lbs)

STANDARD DEVIATION = 30.16 lbs  
 MAXIMUM DEVIATION = 61.65 lbs  
 CORRELATION COEFF. = .96464978

V/V CONVERTED TO LBS BY USING 1ST-DEG SLOPE

Figure A3.- Continued.

INTERACTION  
 NORMAL GAGE UNDER NEGATIVE TENSION  
 SERIAL # :4867  
 MNEMONICS:SIDE GAGE  
 TARE WEIGHT : 0 lbs  
 AVE. ROOM TEMP. : 0 DEG. F  
 FULL-SCALE LOAD : 2000 lbs

T.O. :A-387  
 DATE :8-17-82

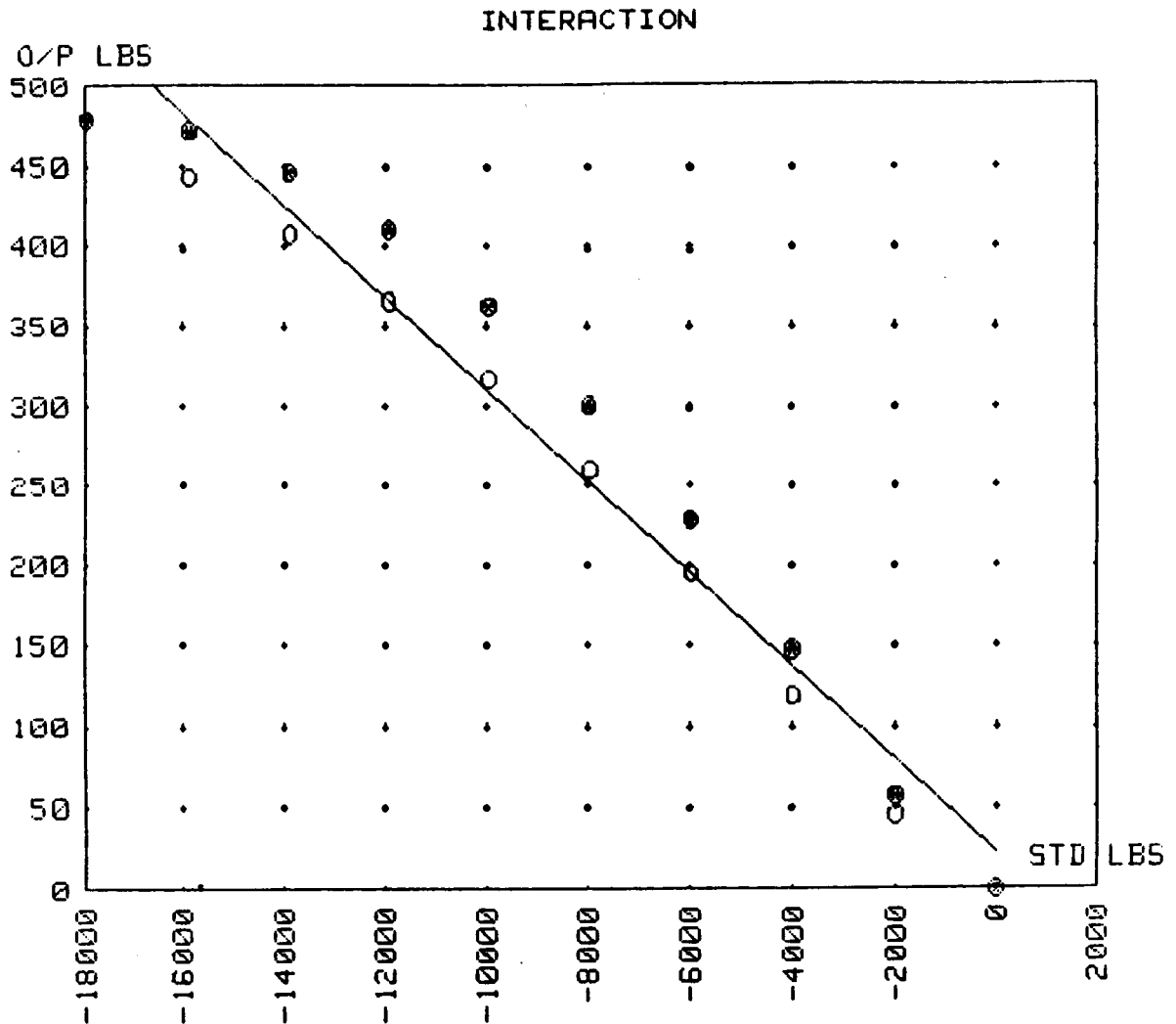

\* SIGN INDICATES FIRST HALF OF THE LOADING CYCLE

RESISTOR = 100 K OHMS

RCAL = .000435 V/V

NO LOAD V/V  
.000014

RCAL V/V  
.000449

SIG PWR  
- -

Figure A3.- Continued.

INTERACTION  
 NORMAL GAGE UNDER + & - TENSION  
 SERIAL # :4867  
 MNEMONICS:SIDE GAGE  
 AVE. ROOM TEMP. : 0 DEG. F  
 FULL-SCALE LOAD : 2000 lbs

T.O. :A-387  
 DATE :8-17-82

RUN #	O/P V	V1	EXCIT.V2 V	(V1-Vo)/V2 V/V-->lbs	STD LOAD lbs	CALC. LOAD lbs	DEV. lbs	ACCU. % (F.S.)
1	.000081	10.03604		0.00	0.00	223.18	223.18	11.159
2	-.000127	10.03605		-45.83	1999.83	214.81	260.63	13.032
3	.000216	10.03602		27.08	3989.66	206.47	179.40	8.970
4	.000690	10.03603		122.15	5981.46	198.13	75.99	3.799
5	.000969	10.03600		178.10	7963.53	189.83	11.73	.586
6	.001201	10.03606		224.63	9947.47	181.52	-43.11	-2.156
7	.001415	10.03610		267.55	11925.88	173.24	-94.32	-4.716
8	.001617	10.03607		308.07	13901.59	164.96	-143.11	-7.155
9	.001794	10.03608		343.57	15864.67	156.74	-186.83	-9.342
10	.001967	10.03608		378.27	17989.07	147.84	-230.43	-11.521
11	.001849	10.03605		354.60	15855.24	156.78	-197.82	-9.891
12	.001705	10.03598		325.72	13887.62	165.02	-160.70	-8.035
13	.001537	10.03596		292.03	11920.62	173.26	-118.77	-5.939
14	.001339	10.03596		252.32	9938.33	181.56	-70.76	-3.538
15	.001119	10.03596		208.19	7961.08	189.84	-18.35	-.918
16	.000870	10.03596		158.25	5974.32	198.16	39.91	1.996
17	.000350	10.03596		53.95	3985.53	206.49	152.54	7.627
18	-.000029	10.03596		-24.24	2000.44	214.80	239.04	11.952
19	.000080	10.03597		-.22	-.24	223.18	223.40	11.170
20	.000075	10.03607		0.00	0.00	223.18	223.18	11.159
21	.000359	10.03607		56.96	-2002.79	231.57	174.61	8.730
22	.000809	10.03611		147.22	-3991.32	239.90	92.68	4.634
23	.001213	10.03615		228.24	-5981.71	248.23	19.99	.999
24	.001572	10.03612		300.25	-7971.10	256.56	-43.68	-2.184
25	.001880	10.03613		362.02	-9951.86	264.86	-97.16	-4.858
26	.002121	10.03606		410.36	-11927.55	273.13	-137.23	-6.861
27	.002300	10.03606		446.26	-13896.23	281.38	-164.88	-8.244
28	.002427	10.03608		471.73	-15865.19	289.62	-182.11	-9.105
29	.002460	10.03612		478.35	-17973.27	298.45	-179.89	-8.995
30	.002285	10.03607		443.25	-15857.21	289.59	-153.66	-7.683
31	.002107	10.03607		407.55	-13886.80	281.34	-126.21	-6.311
32	.001897	10.03608		365.43	-11918.21	273.09	-92.34	-4.617
33	.001653	10.03606		316.49	-9943.10	264.82	-51.67	-2.584
34	.001369	10.03600		259.53	-7958.50	256.51	-3.02	-.151
35	.001044	10.03604		194.35	-5976.16	248.21	53.86	2.693
36	.000666	10.03603		118.54	-3988.78	239.89	121.35	6.068
37	.000300	10.03601		45.13	-1997.56	231.55	186.42	9.321
38	.000100	10.03603		5.01	3.12	223.17	218.15	10.908

BEST FIT STRAIGHT LINE EQUATION :  $Y=A(0)+A(1)*X$   
 Y-INTERCEPT =  $A(0) = 223.1809461$  lbs  
 SLOPE =  $A(1) = -4.18801804632E-03$  (lbs)/(lbs)

STANDARD DEVIATION = 149.94 lbs  
 MAXIMUM DEVIATION = 260.63 lbs  
 CORRELATION COEFF. = .07352824 V/V CONVERTED TO LBS BY USING 1ST-DEG SLOPE

Figure A3.- Continued.

INTERACTION  
 NORMAL GAGE UNDER + & - TENSION  
 SERIAL # :4867  
 MNEMONICS:SIDE GAGE  
 AVE. ROOM TEMP. : 0 DEG. F  
 FULL-SCALE LOAD : 2000 lbs

T.O. :A-387  
 DATE :8-17-82

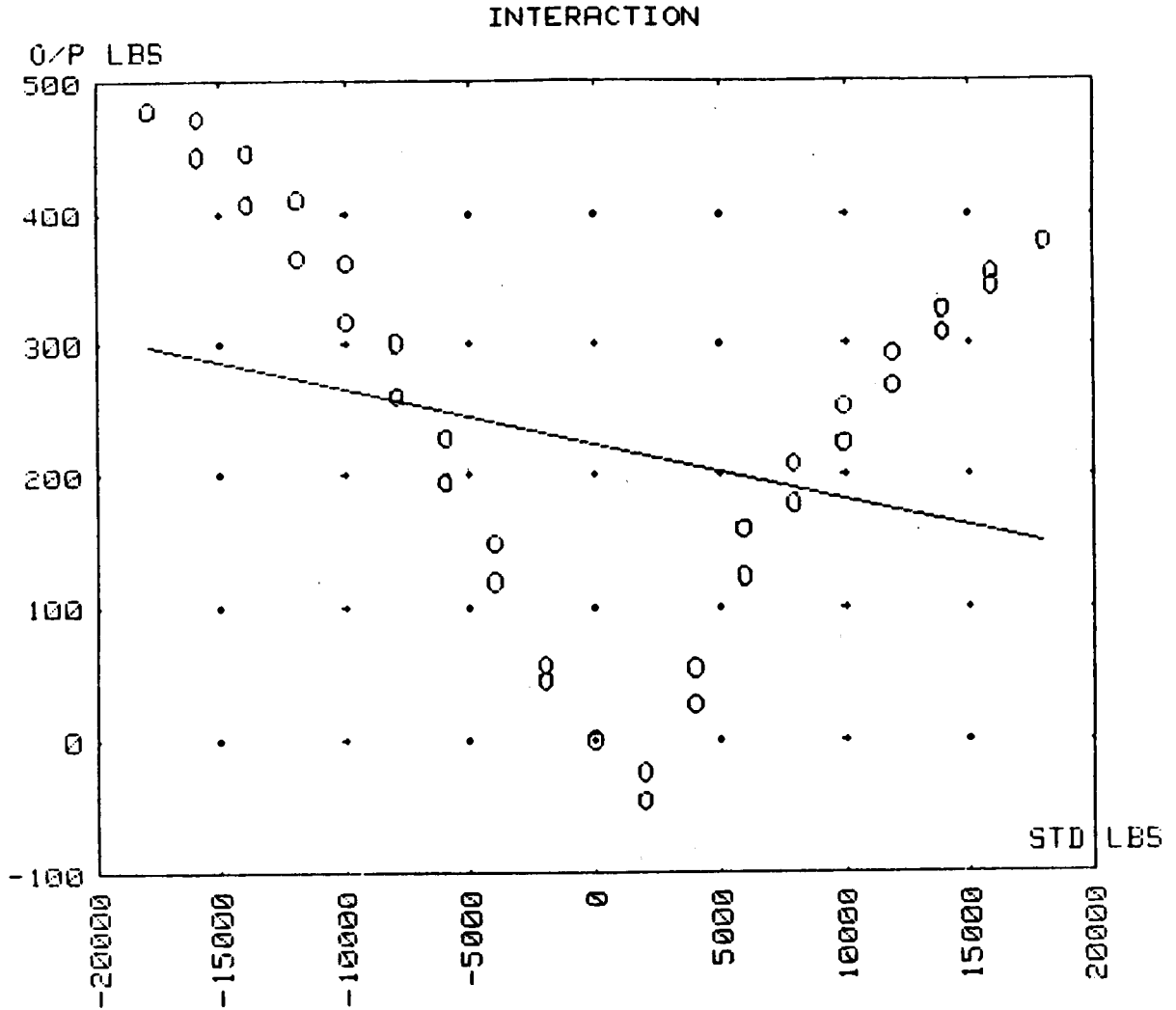

RESISTOR = 100 K OHMS

RCAL = .000435 V/V

NO LOAD V/V

.000014

RCAL V/V

.000449

SIG PWR

- -

Figure A3.- Concluded.

## APPENDIX B

### JET PROPULSION TEST STAND

#### LOAD CELL-LINK INSTALLATION

To install the one-Ax LC links, remove all solid links that are used to transport and store the test stand. The balance table to which models are attached should be resting on four screw snubbers. The snubbers are each labeled from one to four and have a corresponding gage block. The snubbers are adjusted by turning the screw until the distance between the table and the snubber base are equal to the appropriate gage block, figure B1.

With the snubbers adjusted, install the vertical load links. It is important not to preload the links during this phase of the installation as it will cause misalignment that can result in load measurement errors. The best way to avoid preloads is to connect the load cells to a data acquisition system and monitor their output during load cell installation. The links are assembled as shown in figure B1 using the following steps:

1. Assemble the load cell link as shown but leave all jam-nuts loose. Make sure all washers, nuts, and threads are lubricated.
2. Tighten the rods into the load cell by hand until the threads bottom out.
3. Tighten the jam-nuts at the top of the assembly. The spherical washers allow the link to align with the lower hole if the nuts are tightened smoothly. With the upper nuts tightened, the load cell should rotate freely by hand if no parts are binding.
4. Rotate the load cell until the upper rod is backed out a half turn from the bottom. Loosen the lower rod a half turn from being bottomed out from inside the load cell.
5. The load cell output should now be about zero. Tighten one of the lower nuts until the monitor reads approximately 50 to 100 lb. Tighten the remaining nut as tight as possible (nominal 200 ft-lb).
6. With all four nuts tightened, the load cell output should return to zero and the load cell should again rotate freely by hand. There should be no change in the output of the other load cells. If this is not the case, either an axial or lateral preload exists in the link. It is therefore necessary to loosen all the nuts of the link that is being installed and repeat steps 2 through 6.
7. Repeat steps 1 through 6 for the remaining vertical and horizontal load links.

8. When all the necessary load links have been installed and are indicating no loads, screw the snubbers down as far as possible. It is a good idea to securely tighten the snubbers in their lowest position. On occasion, test stand vibration has caused the snubbers to turn until they make contact with the balance table and spoil the data.



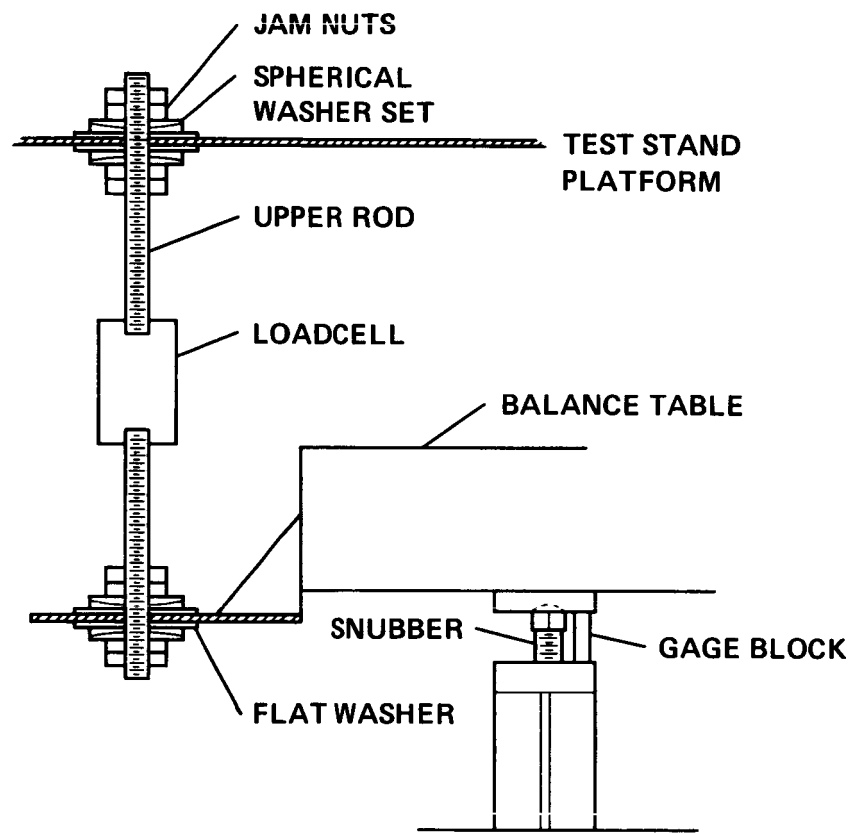

Figure B1.- Propulsion stand loadlink installation.

## APPENDIX C

### SAMPLE CALCULATIONS

#### PRIMARY CONVERSION CONSTANTS, CLDCLS(s,m,n); [force/counts]

Assuming that load cell S.N. 4867 is designated number 2, then for the data presented in appendix A,  $n = 2$  and  $m = 3$ .

Given typical load cell signal conditioning--excitation 10 [V], voltage amplification 1000 [v/v], RMDU analog-digital gain 3333 [cts/v], AMX/RMDU gain 1 [cts/cts]--and noting that the sign convention that is used by the RQ & A lab (appendix A, page 14) is opposite that used by the data reduction program, we use the slope from the data on page 17 of appendix A for the positive loading conversion constant,  $s = 1$ . From page 17:

$$\text{Primary conv.} = 11501052.0 \text{ [lbs/(v/v)]}$$

then

$$\begin{aligned} \text{CLDCLS}(1,3,2) &= \frac{11501052[\text{lbs}/(\text{v}/\text{v})]}{10[\text{v}]1000[\text{v}/\text{v}]3333[\text{cts}/\text{v}]1[\text{cts}/\text{cts}]} \\ &= 0.3451[\text{lbs}/\text{cts}] \end{aligned}$$

We will devote some space here to say a few words about how positive loads are defined. When the lab technicians calibrate a three-Ax LC, they have no idea what the orientation of the load cell will be when mounted on the model. As a result, when the sense of the positive loads are selected as shown in the figure on page 14, they are completely arbitrary. It is up to the test engineer to determine whether or not the positive loadings shown in the lab calibration are consistent with what is assumed to be positive in the load cell data reduction.

As an example we will use the figure on page 14 and assume that the load cell will be mounted on the model with the bolt-circle up and with the electric plug forward. A drag force on the model (positive axial force) will push the load cell back. Since the pin is restrained, the load cell sees a pull on the pin in the direction of the electric plug. This implies that positive axial force is the same for both the model and the lab. On the other hand, lift on the model (positive normal force) will pull the pin away from the bolt circle which is the opposite of the lab definition. Using the same reasoning, it can be shown that positive side force is the same for the lab and the model.

LABORATORY RCAL VALUES, XINCAL(m,n); [counts]

From page 16 of appendix A:

$$\text{rcal} = -0.000434[\text{v/v}]$$

since

$$\text{XINCAL} = \text{rcal} * \text{excitation} * \text{gains}$$

then

$$\begin{aligned} \text{XINCAL}[\text{cts}] &= -0.000434[\text{v/v}] * 10[\text{v}] * 1000[\text{v/v}] * 3333[\text{cts/v}] \\ &= -14,465 \end{aligned}$$

note that the lab has indicated the use of the negative signal and positive power terminals for recording rcal. The present 40 by 80 convention is to use ++. This would result in a sign change for XINCAL.

INTERACTION CONSTANT, DSDN(s,n)

If the interaction slopes are given in units of (v/v)/lb, it will be necessary to multiply this value by the primary conversion constant [lb/(v/v)] of the gage reading the apparent force. Often the RQ & A lab has already done this and the slope can be read directly from the calibration in (lb/lb), see appendix A, page 24. Once the slope is in these units, it can be used for the interaction constant. Care must be taken to account for any reversals of sign conventions, as discussed above, when assigning specific values. As before, for the data provided in appendix A, the n subscript equals 2 and the s subscript indicates the sense of the loading for the gage experiencing the load. From page 24 we have:

$$\text{DSDN}(2,2) = 0.024685 \text{ (lb/lb)}$$

This is the interaction for change in side force at load cell 2 that is due to changes in normal force when the normal gage is being loaded in the negative direction. We use data from the lab's positive loading of the normal gage because of the reversal of the assumed positive direction.

It is a good practice to check the significance of the interactions before inserting them into the data reduction. Interactions of less than 0.1% will have no effect on the data. It is not possible to tell the significance of interactions by their face value. For example, the coefficient listed above gives the change in side force that is due to changes in normal force but says nothing about how that quantity compared with expected side force measurements. An easy way to make that

comparison is to multiply the interaction coefficient by the ratio of the maximum expected force on the influencing gage over the expected force on the influenced gage. For a typical model using this load cell: maximum normal force 10,000 lb, maximum side force 2,000 lb

$$\begin{aligned} \text{Significance} &= \text{DSDN} * \frac{\text{Norm}_{\text{Max}}}{\text{Side}_{\text{Max}}} \\ &= 0.0246 * \frac{10,000}{2,000} = 0.123 = 12.3\% \end{aligned}$$

#### TEMPERATURE COEFFICIENT, CCLDTC(n)

To calculate the temperature correction for a given load cell, it is necessary to have calibration data for that load cell taken at several different ambient temperatures. The coefficient is a linear interpolation of the data that scales the primary conversion constants as a function of the difference between the load cell temperature and a datum temperature.

The coefficients are determined as follows, given:

- $T_{\text{REF}}$  an arbitrary datum reference temperature
- $T$  the measured load cell temperature
- $\Delta T$   $T - T_{\text{REF}}$
- $\text{CLC}_{\text{TREF}}$  laboratory constants  $\text{CLDCLS}(s,m,n)$  acquired at an ambient temperature of  $T_{\text{REF}}$  and used as the inputs for the load cell data reduction program SCELLS
- $\text{CLC}_T$  laboratory constants  $\text{CLDCLS}(s,m,n)$  acquired at some non datum temperature  $T$
- $F_T$  load applied to the load cell at temperature  $T$
- $F_{\text{cts}}$  load cell output in computer counts

the uncorrected load is calculated by

$$F_{\text{TREF}} = \text{CLC}_{\text{TREF}} * F_{\text{cts}}$$

and the calculated corrected load is

$$F_T = CLC_T * F_{cts} = \frac{CLC_T}{CLC_{TREF}} * CLC_{TREF} * F_{cts}$$

$$R = \frac{CLC_T}{CLC_{TREF}}$$

$$F_T = R * F_{TREF} \tag{C1}$$

Making a straight-line interpolation through the data and knowing that the line must pass through  $R = 1.0$  at  $\Delta T = 0.0$ , we have the equation

$$R = (CCLDTC(N) * \Delta T) + 1.0 \tag{C2}$$

where  $CCLDTC(N)$  is the slope of the line.  $CCLDTC(N)$  is defined as the temperature correction coefficient. Substituting (C2) into the equation (C1) above

$$F_T = F_{TREF} ((CCLCTC(N) * \Delta T) + 1.0) \tag{C3}$$

In the absence of a temperature calibration, for load cell flexures made of 17-4 pH stainless steel, the following derivation provides a correction constant that accounts for changes in the modulus of elasticity. Given that

$E_T$  modulus of elasticity at a nonreference temperature

$E_{TREF}$  modulus of elasticity at  $T_{REF}$

$s$  stress in flexure

$F$  force

$e$  strain measured by the gage

$A$  flexure cross-sectional area

since  $e$  and  $A$  are constant for a given load condition, the actual applied force at temperature  $T$  is

$$F_T = s * A = E_T * e * A$$

but the force indicated by the instrumentation will be

$$F_{REF} = E_{REF} * e * A$$

taking the ratio and applying equation (3)

$$\frac{F_T}{F_{TREF}} = \frac{E_T}{E_{TREF}} = (CCLCTC(N) * \Delta T) + 1.0$$

from the Mil. Spec. handbook for 17-4 Ph S.S.

$E_{TREF}$  100% at 80°F

$E_T$  92% at 400°F

so

$$\frac{E_T}{E_{TREF}} = 0.92 = (CCLCTC(N) * (400 - 80)) + 1.0$$

or

$$CCLCTC(n) = -0.000250$$

Load cells that are operated at elevated temperatures often experience significant zero shifts. When increased temperatures are encountered, check zeros at the end of the run.

ORIGINAL PAGE IS  
OF POOR QUALITY

Abbreviations: M = NGAGES (gage no.) N = NLDCLS (loadcell no.)  
FLC(N,M) = FLDCLS(M,N) (gage forces)

Gage output [lbs]  
to local array

Check for pitchtare frame

Read in pitchtare table  
if not in memory

Should tare correction be  
applied to preloads.  
If so IPTARC = 1

Preload tare corrections

Equate preload arrays

Temperature correction

Interaction correction

Store pretare forces

Check for pitchtare frame  
again

Record pitchtares

Should tare correction be  
applied. If so ILTARC = 1

Force tare corrections

Store after tare forces

Rotate loadcell forces  
into body axes

Compute aerodynamic  
forces and moments

Rotate forces into  
the wind and stability axes

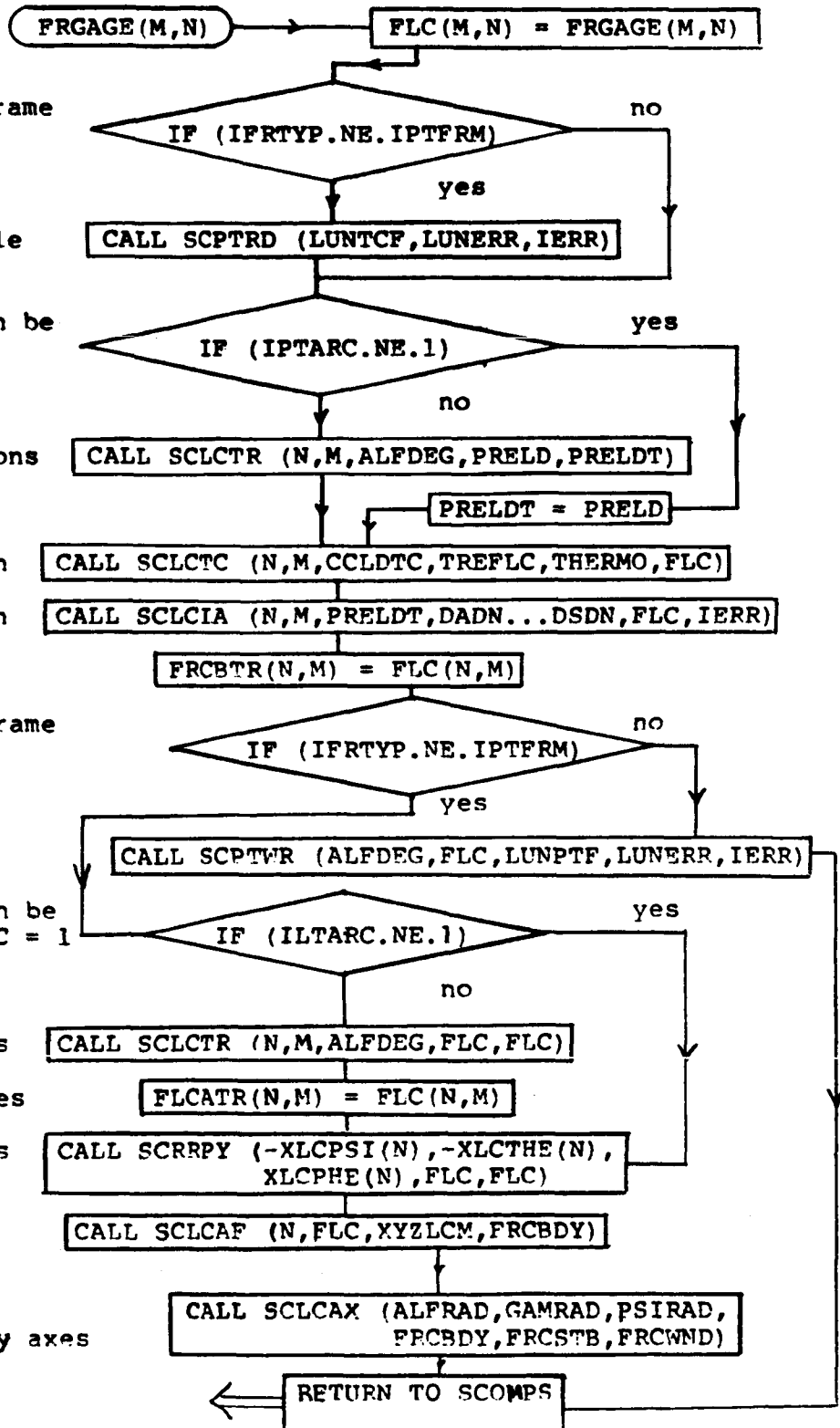

Figure C1.- Flow chart for SCELLS (called by SCOMPS).

FLOW CHART FOR SCPTRD (called by SCELLS)

Transfer of logical unit number for the device containing the TCOF--.DAT files

Check if the correct tare files are in memory

Open the device

Read the tare table TCOF--.DAT corresponding to NTAR = -- for tare alphas and forces

close device

Return to SCELLS

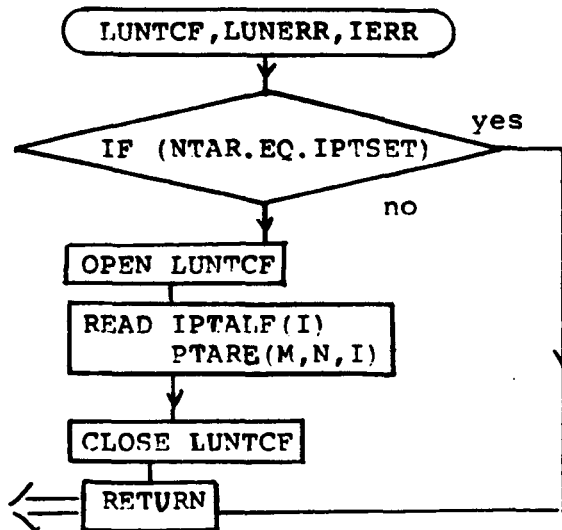

FLOW CHART FOR SCLSTR (called by SCELLS)

Pass alpha, uncorrected forces and returns corrected forces

Look up proper tares

Tare subtraction

Return to SCELLS

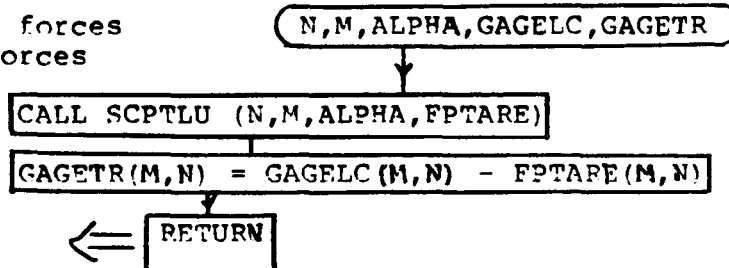

Figure C1.- Concluded.



## APPENDIX D

### PROGRAM DESCRIPTION

#### LOAD CELL FORCE COMPUTATIONS

This appendix describes the computational methods used for the calculation of forces and moments from load cell data. For more detailed information see the actual program listings of the subroutines named. These routines are part of the Ames "Standard Wind Tunnel Software" and can be obtained from NASA programmers or NASA contractor programmers (Informatics).

There are two independent sets of software that can compute loads. The software that performs the on-line calculations during actual running is referred to as the "real-time" program, whereas the program used to reduce the data after a run is called the off-line program. Most subroutines in the off-line program are duplicates of the software in the real-time program; however, in some cases simplified, but equivalent expressions are used in the off-line program.

Prior to any manipulation of data by the so-called "Load Cell Program" SCELLS, the acquired data in the form of machine computer counts is converted into engineering units (eu). These computations are performed in real-time by the standard wind tunnel conversion routines "SCNVRT" which in turn calls "SCTHRB." In the off-line program, the calculation uses the "LOADS" subroutine.

#### SCNVRT: Standard Conversion Routine

This subroutine determines the type of data that needs to be converted (pressure, force transducer, temperature, etc.) and calls the appropriate conversion routine. The subroutine that is called for strain gage balance data is SCTHRB.

#### SCTHRB: Standard Conversion for Thermal Balances

The SCTHRB subroutine contains several options for the conversion of strain gage balance data into engineering units. Its capabilities include (n)th degree bidirectional polynomial conversions, thermal adjustments, resistance calibration, and bias offset corrections. In practice, the load calibration of load cells is linear to within the accuracy of the experimental facility's data system. For this reason only the first-order "thercal" portion of the subroutine is used. If the researcher feels that a higher order fit of the calibration data is justified, that software can be made available upon request. Although this feature could be used to handle second-order effects such as "interactions," a separate subroutine has been supplied for that case.

The first order equation used is

$$FGAGE = CCONST*(XGAGE - IZROCT)*CALCOR \quad (D1)$$

where:

FGAGE, the force measured by a given gage in engineering units.

CCONST, the primary conversion constant [eu/cts]. Also referred to as CLDCLS. CCONST can be assigned values for both positive and negative loadings on each gage, but this feature is only active in the off-line program.

XGAGE, the gage reading in computer counts.

IZROCT, the gage reading recorded during the zero (ZER) point in computer counts.

CALCOR, the real correction factor.

$$CALCOR = XINCAL/FGCAL \quad (D2)$$

XINCAL, reference real value for the gage in computer counts.

FGCAL, the gage reading recorded during the calibration (CAL) point.

It is recommended that if inside-outside real corrections are being applied, any adjustments should be applied directly to the CCONST constant.

During data acquisition, this subroutine performs the following functions:

Zero point, (ZER,PTZ). For either a normal or pitch tare zero the current gage values in counts are stored in IZROCT.

Calibration point, (CAL,PTC). The program assumes that a real; is being applied to the load cell gage and computes the following:

$$FGCAL = CCONST*(FGAGE - IZROCT) \quad (D3)$$

for the calculation of the current values of CALCOR.

Record point, (REC,PTR). Zeros are subtracted and conversions applied as described in equation (D1).

#### SCELLS: Standard Computation of Load Cells Data

The SCELLS subroutine takes the gage force readings for the various load cells that are computed by SCTHRB (in engineering units), and applies temperature

corrections, interactions, and tare corrections. It rotates the force vectors from load cell to model axes to compute aerodynamic forces and moments. Finally, it rotates the forces and moments into the desired axes system. It is not always necessary to apply all of these corrections, so provisions are available to flag out any routines that are not required. The following subroutines are called by SCELLS in the order shown in the accompanying flow chart.

SCPTRD: Standard Computations, Pitch Tare Read

If the current run is not for the purpose of recording new pitch tare values (PTZ, PTC, or PTR), the pitch tare file corresponding to the present value of NTAR is read into memory.

SCLCTR: Standard Computations, Load Cell Tare Correction

The tare correction is a simple subtraction of the tare value that is associated with the current angle of attack, on a gage-by-gage basis,

$$GAGETC(N,M) = GAGELC(N,M) - FPTARE(N,M) \quad (D4)$$

If the flag IPTARC is set to 1, pitch tares will also be applied to the preloads. Since preloads are reversed, sign (positive preloads for negative loads) negative preload values are sent to, and returned from, the subroutine.

$$-PRELDT(N,M) = -PRELD(N,M) - FPTARE(N,M) \quad (D5)$$

SCPTLU: Standard Computations, Pitch Tare Lookup

This subroutine looks up the set of tare values that is appropriate for the current angle of attack. If no data are present for the present test condition, then values are computed by linear interpolation from adjacent data,

$$FPTARE = \frac{(PTAR_{HI} - PTAR_{LO}) * (ALPHA - ALF_{LO})}{ALF_{HI} - ALF_{LO}} + PTAR_{LO} \quad (D6)$$

If alpha is not within the range of the tare data, tare values associated with the closest alpha will be used. No extrapolations are made. Care should be exercised when using the interpolated tare values. This feature is intended to provide an approximation to what can be a highly nonlinear function. Should the data warrant, it is possible to insert additional tare values into the file before recomputing. WARNING: This routine rounds off to the nearest integer alpha.

## SCLCTC: Standard Computations, Load Cell Temperature Correction

This subroutine adjusts the slope of the primary load cell calibration as a function of load cell temperature. This subroutine is discussed in detail in appendix C.

## SCLCIA: Standard Computations, Load Cell Interactions

The term interaction applies to a fictitious force indicated by a load cell gage that is due to deflections normal to its load axis. The manner in which the Ames three-component load cells are constructed (described in the main body of this paper) provides a physical isolation between the gages of different load cells; so it can be assumed that interactions between the load cells do not exist. This simplification allows the subroutine SCLCIA to apply corrections to the indicated loads based only on the influence coefficients that are common to each load-cell.

The interaction subroutine is implemented in three steps. The first determines if a gage is in tension or in compression. The equations are

$$IDLA = IDLS = IDLN = 1 \quad (D7)$$

IF (FRGAGE(IAXIL,N) .LT. PRELD(IAXIL,N)) IDLA = 2

IF (FRGAGE(ISIDE,N) .LT. PRELD(ISIDE,N)) IDLS = 2

IF (FRGAGE(INRML,N) .LT. PRELD(INRML,N)) IDLN = 2

Where FRGAGE and PRELD and their subscripts are as defined earlier, IDLA, IDLS, and IDLN are the *s* subscript, as discussed in the main body of this paper, which denotes the sign associated with the influence coefficients (positive = 1, negative = 2).

The second step computes the apparent force increment as seen by each gage

$$DAFRC = FRGAGE(INRML,N)*DADN(IDLN,N) + FRGAGE(ISIDE,N)*DADN(IDLS,N)$$

$$DSFRC = FRGAGE(IAXIL,N)*DADN(IDLA,N) + FRGAGE(ISIDE,N)*DADN(IDLS,N) \quad (D8)$$

$$DNFRC = FRGAGE(IAXIL,N)*DADN(IDLA,N) + FRGAGE(INRML,N)*DADN(IDLN,N)$$

and the final step subtracts the increment from each gage

$$FRCORR(IAXIL,N) = FRGAGE(IAXIL,N) - DAFRC$$

$$FRCORR(ISIDE,N) = FRGAGE(ISIDE,N) - DSFRC \quad (D9)$$

$$FRCORR(INRML,N) = FRGAGE(INRML,N) - DNFRC$$

### SCRRPY: Rotation of Roll-Pitch-Yaw

In order to align the forces that are measured by the load cells with the model's body axes, this subroutine sequentially rotates the force vector FLDCLS about the roll, pitch, and yaw axes (X-Y-Z) for each gage of each load cell (euler convention). The actual rotations are performed by the subroutines SCROLL, SCPTCH, and SCYAW. The transformation equations are given below.

Rotation about load cell X-axis (D10)

$$\begin{aligned} \text{FLDCLS}(1,N) &= \text{FLDCLS}(1,N) \\ \text{FLDCLS}(2,N) &= \text{COS}(\text{XLC PHE}) * \text{FLDCLS}(2,N) - \text{SIN}(\text{XLC PHE}) * \text{FLDCLS}(3,N) \\ \text{FLDCLS}(3,N) &= \text{COS}(\text{XLC PHE}) * \text{FLDCLS}(3,N) + \text{SIN}(\text{XLC PHE}) * \text{FLDCLS}(2,N) \end{aligned}$$

Rotation about intermediate Y-axis (D11)

$$\begin{aligned} \text{FLDCLS}(1,N) &= \text{COS}(-\text{XLCTHE}) * \text{FLDCLS}(1,N) - \text{SIN}(-\text{XLCTHE}) * \text{FLDCLS}(3,N) \\ \text{FLDCLS}(2,N) &= \text{FLDCLS}(2,N) \\ \text{FLDCLS}(3,N) &= \text{COS}(-\text{XLCTHE}) * \text{FLDCLS}(3,N) + \text{SIN}(-\text{XLCTHE}) * \text{FLDCLS}(1,N) \end{aligned}$$

Rotation about second intermediate Z-axis into Model's axes (D12)

$$\begin{aligned} \text{FLDCLS}(1,N) &= \text{COS}(-\text{XLCPSI}) * \text{FLDCLS}(1,N) + \text{SIN}(-\text{XLCPSI}) * \text{FLDCLS}(2,N) \\ \text{FLDCLS}(2,N) &= \text{COS}(-\text{XLCPSI}) * \text{FLDCLS}(2,N) - \text{SIN}(-\text{XLCPSI}) * \text{FLDCLS}(1,N) \\ \text{FLDCLS}(3,N) &= \text{FLDCLS}(3,N) \end{aligned}$$

Note that the subscripts 1,2, and 3 associate items to the axial, side, and vertical directions as described earlier in this paper.

### SCLCAF: Load Cell Aerodynamic Forces

The computation of forces is a simple summation of the measured load cell forces after they have been rotated into the model body axes.

For N = 1 to NLDCLS (D13)

$$\text{AEROFB}(1) = \text{AEROFB}(1) + \text{GAGEFB}(1,N)$$

$$\text{AEROFB}(2) = \text{AEROFB}(2) + \text{GAGEFB}(2,N)$$

$$\text{AEROFB}(3) = \text{AEROFB}(3) + \text{GAGEFB}(3,N)$$

NLDCLS is equal to the total number of load cells.

The moment calculation is performed in a similar manner. For each load cell, the force components are multiplied by their respective moment arms and summed.

For N = 1 to NLDCLS

(D14)

$$\begin{aligned} \text{AEROFB(ROLL)} &= \text{AEROFB(ROLL)} + [\text{GAGEFB}(2,\text{N}) * \text{XLCXYZ}(3,\text{N})] \\ &\quad - [\text{GAGEFB}(3,\text{N}) * \text{XLCXYZ}(2,\text{N})] \end{aligned}$$

$$\begin{aligned} \text{AEROFB(PTCH)} &= \text{AEROFB(PTCH)} + [\text{GAGEFB}(1,\text{N}) * \text{XLCXYZ}(3,\text{N})] \\ &\quad - [\text{GAGEFB}(3,\text{N}) * \text{XLCXYZ}(1,\text{N})] \end{aligned}$$

$$\begin{aligned} \text{AEROFB(YAW)} &= \text{AEROFB(YAW)} + [\text{GAGEFB}(1,\text{N}) * \text{XLCXYZ}(2,\text{N})] \\ &\quad - [\text{GAGEFB}(2,\text{N}) * \text{XLCXYZ}(1,\text{N})] \end{aligned}$$

SCLCAX: Axes Rotations

### LOAD CELLS, MODEL FORCES, AND MOMENTS

The final load cell subroutine calculates the forces and moments in wind and stability axes. The wind axes system is the conventional Earth-axes system with the restriction that the relative wind is parallel to its X-axis. For this case, the stability Z-axis is parallel to the wind Z-axis; the stability Y-axis is parallel to the body Y-axis; and the stability X-axis is in the X-Y plane of the wind axes and the X-Z plane of the body axes. The transformation equations are as follows:

Roll then Pitch Body Forces and Moments into Stability Axes

ROLL

(D15)

$$\begin{aligned} \text{FSTAB(DRAG)} &= \text{FBODY(DRAG)} \\ \text{FSTAB(SIDE)} &= \text{COS}(-\text{GAMMA}) * \text{FBODY(SIDE)} - \text{SIN}(-\text{GAMMA}) * \text{FBODY(LIFT)} \\ \text{FSTAB(LIFT)} &= \text{COS}(-\text{GAMMA}) * \text{FBODY(LIFT)} + \text{SIN}(-\text{GAMMA}) * \text{FBODY(SIDE)} \end{aligned}$$

$$\begin{aligned} \text{FSTAB(ROLL)} &= \text{FBODY(ROLL)} \\ \text{FSTAB(PTCH)} &= \text{COS}(\text{GAMMA}) * \text{FBODY(PTCH)} - \text{SIN}(\text{GAMMA}) * \text{FBODY(YAW)} \\ \text{FSTAB(YAW)} &= \text{COS}(\text{GAMMA}) * \text{FBODY(YAW)} + \text{SIN}(\text{GAMMA}) * \text{FBODY(PTCH)} \end{aligned}$$

PITCH

(D16)

$$\begin{aligned} \text{FSTAB(DRAG)} &= \text{COS}(-\text{ALPHA}) * \text{FSTAB(DRAG)} - \text{SIN}(-\text{ALPHA}) * \text{FSTAB(LIFT)} \\ \text{FSTAB(SIDE)} &= \text{FSTAB(SIDE)} \\ \text{FSTAB(LIFT)} &= \text{COS}(-\text{ALPHA}) * \text{FSTAB(LIFT)} + \text{SIN}(-\text{ALPHA}) * \text{FSTAB(DRAG)} \\ \text{FSTAB(ROLL)} &= \text{COS}(-\text{ALPHA}) * \text{FSTAB(ROLL)} - \text{SIN}(-\text{ALPHA}) * \text{FSTAB(YAW)} \\ \text{FSTAB(PTCH)} &= \text{FSTAB(PTCH)} \\ \text{FSTAB(YAW)} &= \text{COS}(-\text{ALPHA}) * \text{FSTAB(YAW)} + \text{SIN}(-\text{ALPHA}) * \text{FSTAB(ROLL)} \end{aligned}$$

YAW forces and moments into wind axes

(D17)

$$FWIND(DRAG) = \cos(\psi) * FSTAB(DRAG) + \sin(\psi) * FSTAB(SIDE)$$

$$FWIND(SIDE) = \cos(\psi) * FSTAB(SIDE) - \sin(\psi) * FSTAB(DRAG)$$



$$FWIND(LIFT) = FSTAB(LIFT)$$

$$FWIND(ROLL) = \cos(\psi) * FSTAB(ROLL) - \sin(\psi) * FSTAB(PTCH)$$

$$FWIND(PTCH) = \cos(\psi) * FSTAB(PTCH) + \sin(\psi) * FSTAB(ROLL)$$

$$FWIND(YAW) = FSTAB(YAW)$$



1. Report No. NASA TM-86693		2. Government Accession No.		3. Recipient's Catalog No.	
4. Title and Subtitle EXPERIMENTAL TECHNIQUES FOR THREE-AXES LOAD CELLS USED AT THE NATIONAL FULL-SCALE AERODYNAMICS COMPLEX				5. Report Date September 1985	
				6. Performing Organization Code	
7. Author(s) Michael R. Dudley				8. Performing Organization Report No. 85150	
9. Performing Organization Name and Address Ames Research Center Moffett Field, CA 94035				10. Work Unit No. T-4526	
				11. Contract or Grant No.	
12. Sponsoring Agency Name and Address National Aeronautics and Space Administration Washington, DC 20546				13. Type of Report and Period Covered Technical Memorandum	
				14. Sponsoring Agency Code 505-43-01	
15. Supplementary Notes Point of Contact: Michael R. Dudley, Ames Research Center, MS 233-1, Moffett Field, CA 94035 (415)694-5046 or FTS 464-5046					
16. Abstract <p>This memorandum provides the necessary information for an aerodynamic investigation requiring load cell force measurements at the National Full-Scale Aerodynamics Complex (NFAC). Included here are details of the Ames 40 by 80 three-component load cells; typical model/load cell installation geometries; transducer signal conditioning; a description of the Ames Standard Computations Wind Tunnel Data Reduction Program for Load Cells Forces and Moments (SCCELLS), and the inputs required for SCCELLS. The Outdoor Aerodynamic Facilities Complex (OARF), a facility within the NFAC where three-axes load cells serve as the primary balance system, is used as an example for many of the techniques, but the information applies equally well to other static and wind tunnel facilities that make use of load cell balances.</p> <p>This paper can serve either as a user guide for NASA and contract engineers who are preparing to conduct an investigation at the OARF or at the NFAC, or as a description of techniques, data systems, and hardware that is currently used for ground-based aerodynamic investigations which measure forces with three-axes load cells.</p>					
17. Key Words (Suggested by Author(s)) Three-axes load cell Ground-based Aerodynamic testing Full-scale			18. Distribution Statement Unclassified   Subject Category - 05		
19. Security Classif. (of this report) Unclassified		20. Security Classif. (of this page) Unclassified		21. No. of Pages 56	22. Price*