

MCR-86-528  
NAS9-17230

CR-172006

TWS  
Final  
Report

May 1987

# Telepresence Work Station System Definition Study— Part II

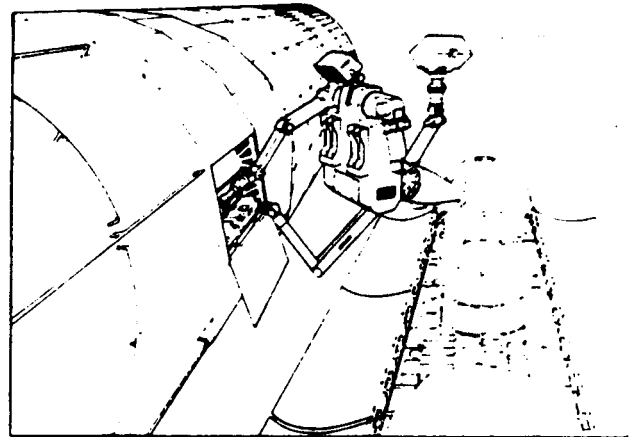

(NASA-CR-172006) TELEPRESENCE WORK STATION  
SYSTEM DEFINITION STUDY, PART 2 Final Report  
(Martin Marietta Corp.) 65 p Avail: NTIS  
HC A04/MF A01 CSCI 22B

N88-10071

Unclas  
33/18 0098605

**MARTIN MARIETTA**

**MCR-86-528**  
**NAS9-17230**

**TWS**  
**Final**  
**Report**

**May 1987**

---

**TELEPRESENCE WORK  
STATION SYSTEM  
DEFINITION STUDY—  
PART II**

**MARTIN MARIETTA**  
**DENVER AEROSPACE**  
P.O. Box 179  
Denver, Colorado 80201

FOREWORD

---

This study was conducted for the Lyndon B. Johnson Space Center (JSC) under National Aeronautics and Space Administration (NASA) Contract NAS9-17230 by the Martin Marietta Denver Aerospace Corporation. Mr. Lyle M. Jenkins was NASA's Technical Monitor. Mr. Thomas M. Depkovich was the Martin Marietta Study Manager.

Request for information on this study should be addressed to:

Mr. Lyle M. Jenkins  
NASA JSC Technical Monitor  
(713) 483-3278

Mr. Thomas M. Depkovich  
Martin Marietta Study Manager  
(303) 977-6013

## GLOSSARY

---

AFD	Aft Flight Deck
AFWAL	Air Force Wright Aeronautical Laboratory
AI	Artificial Intelligence
CCD	Charge-Coupled Device
CMOS	Complementary Metal-Oxide Semiconductor
CRT	Cathode Ray Tube
DARPA	Defense Advanced Research Projects Agency
DOF	Degree of Freedom
EPSP	Electrical Power Service Panel
EVA	Extravehicular Activity
FRHC	Force-Reflecting Hand Controller
FSS	Flight Service Station
FTS	Flight Telerobotic Servicer
GSFC	Goddard Space Flight Center
ICD	Interface Control Document
I/O	Input/Output
IOC	Initial Operating Capability
IR&D	Independent Research and Development
IRSS	Intelligent Robotic System Study
ITA	Intelligent Task Automation
JPL	Jet Propulsion Laboratory
JSC	Johnson Space Center
LCD	Liquid Crystal Display
MFD	Multifunction Display
MMU	Manned Maneuvering Unit
MOD	Magneto-Optic Display
MSCS	Mobile Servicing Center System
MSFC	Marshall Space Flight Center
NASA	National Aeronautics and Space Administration
OMV	Orbital Maneuvering Vehicle
ORU	Orbital Replacement Unit

PFMA      Protoflight Manipulator Arm  
PDP      Plasma Display Panel  
PSDP      Payload Station Distribution Panel  
R&D      Research and Development  
RGB      Red, Green, Blue  
RMS      Remote Manipulator System  
ROM      Rough Order of Magnitude  
SIP      Standard Interface Panel  
SMCH      Standard Mixed Cabling Harness  
SS      Space Station  
SSP      Standard Switch Panel  
STS      Space Transportation System  
TFEL      Thin Film Electroluminescence  
TWS      Telerobotic Work System  
VFD      Vacuum Florescent Display

## CONTENTS

---

	<u>Page</u>
1.0 INTRODUCTION . . . . .	1
2.0 PRELIMINARY SYSTEM REQUIREMENTS . . . . .	5
3.0 SYSTEM CONCEPTS . . . . .	10
3.1 Telerobot Workstation . . . . .	11
3.2 Control Station . . . . .	22
3.3 Processing and Control . . . . .	37
4.0 INTERFACE DEFINITION . . . . .	46
4.1 STS/RMS Electrical Interface . . . . .	46
4.2 STS Physical Interface . . . . .	50
4.3 OMV Interface. . . . .	51
5.0 PROGRAM PLAN . . . . .	53
6.0 CONCLUSIONS AND RECOMMENDATIONS . . . . .	58

## Figure

---

1-1 TWS System Concept . . . . .	3
2-1 TWS Requirements Development . . . . .	5
3-1 TWS System Concepts . . . . .	10
3-2 TWS Workstation . . . . .	11
3-3 TWS System Design . . . . .	12
3-4 TWS Degrees of Freedom . . . . .	14
3-5 Manipulator/Stabilizer Design. . . . .	15
3-6 Manipulator/Stabilizer Design Detail . . . . .	16
3-7 Compact Wrist Concept . . . . .	16
3-8 Reconfigurable Arm Family . . . . .	17
3-9 End Effector/Grappler Design . . . . .	18
3-10 Vision Head Design . . . . .	19
3-11 Chest Package . . . . .	21
3-12 Control Station Layout . . . . .	23
3-13 Candidate Flat Screen Technologies . . . . .	27
3-14 Shutter Stereo System . . . . .	31
3-15 Reflective Stereo Display System . . . . .	32
3-16 Hand Controller Design . . . . .	34
3-17 Stowage of Control Station . . . . .	36
3-18 Control Station Deployed Location . . . . .	36
3-19 TWS System Processing . . . . .	38
3-20 TWS Control Station Configuration . . . . .	40
3-21 Workstation Processing Architecture . . . . .	43
3-22 TWS Control System Concept . . . . .	44
3-23 TWS Control System Concept Flow Diagram . . . . .	45

4-1	Signal Wire Routing . . . . .	47
4-2	Wire Routing on RMS . . . . .	48
4-3	TWS Berthing/Location . . . . .	50
4-4	TWS Shuttle Bay Restraint System . . . . .	51
5-1	Robotic Servicer . . . . .	54
5-2	Robotic Servicer in a Deployed Mode . . . . .	55
5-3	Program Plan . . . . .	56

Table

---

2-1	Functional Requirements . . . . .	6
2-2	Robotic Space Station Assembly Candidates . . . . .	7
2-3	Key TWS Servicer Configuration Requirements . . . . .	8
2-4	Key TWS Test Bed Configuration Requirements . . . . .	9
3-1	TWS Workstation Tradeoff Results . . . . .	12
3-2	Workstation Weight and Power . . . . .	21
3-3	Control Station Tradeoff Results . . . . .	24
3-4	Flat Screen Technology Performance Comparison . . . . .	30
3-5	Control Station Processing Tasks . . . . .	39
3-6	Workstation Processing Tasks . . . . .	42
4-1	OMV-Configured TWS Power Equipment List . . . . .	52
5-1	Telerobot Workstation Cost Estimate . . . . .	57
5-2	Control Station Cost Estimate . . . . .	57

## 1.0 INTRODUCTION

---

The Telerobotic Work System (TWS) Definition Study is a two-part effort initiated in 1985. The overall objective of the study effort was to define a system that would have the capabilities for performing a wide variety of remote operation missions in space. A very important aspect of this study has been the focus on near-term (present to 1994) mission scenarios as well as longer term scenarios (1995 and beyond). This perspective has been maintained throughout the study effort and has resulted in requirements and system concepts that maximize the use of existing robotic technology while supporting the evolution of the system from telerobotic control through supervisory control and, finally, into autonomous control.

Although TWS was initiated as an independent program, close contact has been maintained with the space station robotics community. Based on review of literature from the Goddard Space Flight Center (GSFC), TWS represents a viable baseline for the Flight Telerobotic Servicer (FTS) system. In the development of the requirements for the TWS, the same mission set that is being used for the FTS was considered.

The TWS study has examined the four tasks described below:

- Task 1: Requirements Definition
- Task 2: System Concept
- Task 3: Interface Definition
- Task 4: Program Plan

The Requirements Definition task has examined and developed requirements for the TWS. In the course of this task, a wide variety of mission scenarios have been examined such as satellite servicing, space assembly, and contingency operations. Mission functional requirements were drawn from both previous industry and government studies as well as current NASA data.



The System Concept task has resulted in the definition of a dual-arm servicing system that:

- 1) Maximizes the use of technology that has been developed for space robotic missions,
- 2) Incorporates the capability for implementing robotic control techniques that are now reaching maturity in numerous Research and Development (R&D) programs,
- 3) Ensures the growth capability for later expansion of processing and data acquisition subsystems that will allow the use of additional sensors, more sophisticated control algorithms, and other capabilities such as machine vision and artificial intelligence (AI) planners.

Our TWS concept is comprised of three primary subsystems: the telerobot workstation, the control station, and the processing and control subsystem.

The basic attributes of the telerobot workstation are shown in Figure 1-1. The two 7-degree-of-freedom (DOF) manipulator arms use the proven dual-path, preloaded joint design concept used on the original Protoflight Manipulator Arm (PFMA). Additional dexterity is provided through a compact 3-DOF wrist-design originally conceived by Mark Rosheim. In addition to position and velocity sensing on each joint axis, each arm is also equipped with a 6-DOF wrist-mounted force/torque sensor and electro-optical proximity sensors. A quick disconnect wrist device provides the capability for using either a parallel jaw gripper or a variety of special tools.

The stabilizer system employs the same basic design as the primary arm system, enhancing system redundancy. Tentatively, a single stabilizing arm is used, although stabilizer requirements are being further studied under Martin Marietta's internal research and development (IR&D) D-75D, Robotic Systems Technology.

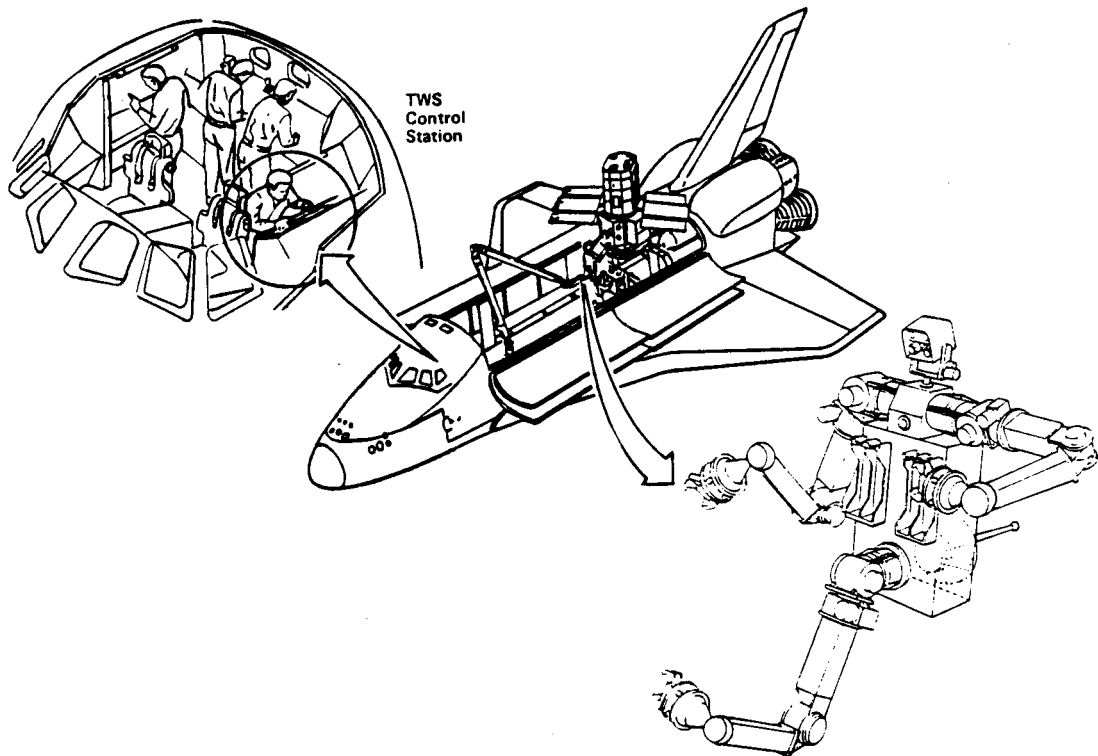

*Figure 1-1 TWS System Concept*

The primary vision system is a stereo camera pair mounted on a 2-DOF pan/tilt gimbal system. The stereo camera pair is augmented with arm-mounted cameras.

All power and control electronics required by the workstation are contained in the chest package. The space requirement for electronics is approximately 2.5 ft<sup>3</sup>. The chest package has been designed to accommodate a variety of interface devices. This feature was included to allow a single integrated design of the main electronics module and housing.

Two design concepts were developed for the control station. In Part I of the study, a control station was designed that installed in the aft flight deck (AFD) of the shuttle in Panels L10 and L11. In Part II of the study, this design was modified to make it more portable and less costly to interface. The system designed in Part II is small enough to be stowed in one mid-deck stowage locker during launch and landing, but

is still deployed in-flight in the shuttle's AFD. Stereo viewing is accomplished via an onscreen, polarized, shutter-type viewing system. Teleoperator input to the manipulators is accomplished using two 6-DOF joysticks in both concepts that provide the capability for position, rate, and bilateral force reflection control.

In developing our concepts for the control and processing subsystem, we have drawn heavily on related contract and IR&D experience in this area. The significant feature of the recommended control system structure is the use of local force/torque feedback loops at each manipulator. Baseline processing architectures have been defined that closely parallel systems currently running in our laboratories and under development for use with the PFMA at Marshall Space Flight Center (MSFC).

In the Interface Definition task, both the Space Transportation System (STS) and the Orbital Maneuvering Vehicle (OMV) baseline were examined to determine interface requirements. Because of substantial communication and power requirements in the case of the STS/Remote Manipulator System (RMS) combination, an additional umbilical cable was specified in addition to power and signal available through the RMS. The OMV interface creates some problems from the standpoint of power and communication requirements, however, it appears these problems can be overcome through the use of augmented battery power and signal compression techniques.

In the Program Plan task, a timetable was formulated for the development of both test bed and operational TWS systems geared toward Space Station initial operating capability (IOC) in 1994.

## 2.0 PRELIMINARY SYSTEM REQUIREMENTS

---

The flowchart in Figure 2-1 depicts the hierarchical requirements development process used to establish a comprehensive set of conceptual and preliminary design requirements for the TWS.

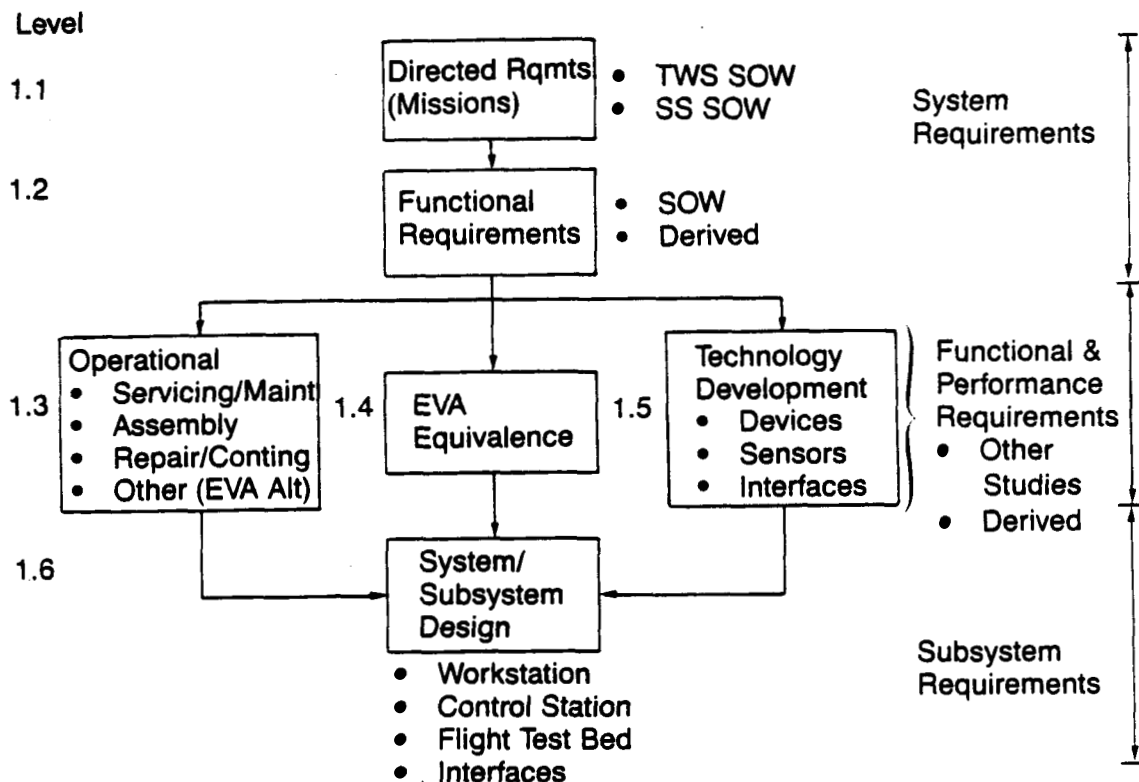

Figure 2-1 TWS Requirements Development

Directed requirements from the TWS and Space Station Phase B statements of work specify the top-level missions and performance envelopes for the TWS servicer and test bed configurations. The scope of the required missions includes functional extravehicular activity (EVA) equivalent performance capabilities for assembly, servicing, repair, and inspection at the Space Station, in the STS cargo bay for satellite servicing and repair, and *in situ* satellite servicing and repair using the OMV for mobility and support. In addition, the TWS design must accommodate a flight test bed configuration for development of new telerobotic technologies.

From the directed requirements, a list of functional requirements was derived that represents the operations required to be performed for the given TWS missions. This list of functional requirements is given in Table 2-1 below.

*Table 2-1 Functional Requirements*

- Inspection, Photography
- Installation, Removal, Transfer of Components
- Equipment Operation
  - Tools
  - Devices
- Cleaning
- Connection/Disconnection
  - Fluid
  - Electrical
- ORU Replacement
- Repairs/Repositioning
- Activating/Deactivating Equipment
- Boom Manipulation
- Cargo Transfer
- Construction
- General Satellite Servicing

Data from the Space Station Assembly Sequence Technical Interchange Panel meetings were used to compile a list of candidate robotic assembly and servicing tasks, which were added to the satellite servicing operational requirements developed in the TWS Part I effort. With the exception of a few assembly tasks, such as the truss buildup, insufficient data are available from the Space Station Phase B studies to derive detailed operational requirements. This information will become accessible during the Phase C/D Space Station effort. Table 2-2 lists the currently identified candidate robotic assembly operations.

*Table 2-2 Robotic Space Station Assembly Candidates*

- o Erecting Truss Structure
- o Installing Utility Trays and Cable Runs
- o Module Installation and Umbilical Connection
- o Attached Payload Support Equipment Installation
- o Radiator Panel Assembly and Installation
- o Closeout Inspection and Documentation
- o General EVA Assistance
  - Materials Handling/Positioning
  - Stand-In for Hazardous Operations
  - Nondestructive Testing

In addition to the requirements derived from the EVA functional equivalence goal in the TWS Part I effort, performing EVA servicing operations on satellites in space will produce new requirements on the servicer configuration to gain access to worksites and provide a stabilized interface for servicing. Depending on the docking and mobility approach chosen, the TWS will require either a separate positioning device (such as the RMS) or the capability to be reconfigured with longer manipulators and stabilizers to reach orbital replacement units (ORU) from distant docking locations. This implies the requirement for a modular, reconfigurable TWS to accommodate a wide range of missions and customer worksite configurations.

Technology development requirements identified during Part II focus on the need to (1) develop the details of a modular, reconfigurable TWS in the design area; (2) assess technology readiness to support the TWS and Space Station time lines; and (3) assure compatibility of interfaces with host accommodations under development.

System and subsystem design requirements derived during Part I were examined and upgraded where applicable. In general, no new information was available on host vehicle (OMV, Mobile Servicing Center System

[MSCS]) designs or interfaces, and the existing requirements set is comprehensive and compatible with the requirement for a modular servicer design.

Finally, lists of requirements that are key design drivers for the operational TWS and TWS test bed configurations were derived. These requirements are those that are either of primary programmatic importance, or that imply major design, analytical, and/or simulation efforts to achieve. Table 2-3 list the key design drivers for the operational TWS, and Table 2-4 lists the key design influences for the TWS test bed configuration.

*Table 2-3 Key TWS Servicer Configuration Requirements*

<u>Requirement</u>	<u>Design Impacts</u>
<ul style="list-style-type: none"> <li>• Functional EVA Equivalence</li> </ul>	<ul style="list-style-type: none"> <li>— Number of Manipulators</li> <li>— Dexterity Required</li> <li>— Manipulator Configuration</li> <li>— End Effector/Tools</li> <li>— Vision System</li> </ul>
<ul style="list-style-type: none"> <li>• Servicing At Space Station and <i>In Situ</i></li> </ul>	<ul style="list-style-type: none"> <li>— Docking/Stabilizing Device(s)</li> <li>— Manipulator Lengths (Modular)</li> </ul>
<ul style="list-style-type: none"> <li>• Ground Control</li> </ul>	<ul style="list-style-type: none"> <li>— Control Strategy (Time Delay)</li> <li>— Processing Architecture</li> </ul>
<ul style="list-style-type: none"> <li>• Mobility/Support Interfaces (RMS, OMV, MSCS)</li> </ul>	<ul style="list-style-type: none"> <li>— Power Subsystem Design</li> <li>— Communications (Bandwidth Restrictions)</li> </ul>

*Table 2-4 Key TWS Test Bed Configuration Requirements*

<u>Requirement</u>	<u>Design Element Affected</u>
• Demonstrate Comprehensive Performance Capabilities	— Task Panel/Pallet Design
• Reconfigurable Task Accommodations	— Task Panel/Pallet Design
• Accommodate Variations in Telerobot Configuration	— Manipulators (Modular) — Vision System — Control Station — Control Software
• Minimize NSTS Integration Effects	— Control Station Design — Manipulator Lengths and Location — Power Consumption — Structural Interfaces



### 3.0 SYSTEM CONCEPTS

---

This section describes the preliminary design concepts that were developed for the Telerobotic Work System. Figure 3-1 shows the subsystem decomposition that was used for the major part of the study. The Telerobot Work Station consists of the manipulator arms, the stabilizer, and effectors, sensor systems, and the main chest package. The control station consists of video and graphics displays, system monitoring and switching devices, hand controllers, and the control station housing. In the early phases of this study it was assumed that the telerobot work station and control station would be the two primary subsystems. As the study progressed, however, it became apparent that a third subsystem was necessary--control and processing. The need for this third subsystem was necessitated by the difficulty in partitioning processing tasks between the other two subsystems. This issue as well as the resulting subsystem concept will be discussed in Section 3.3.

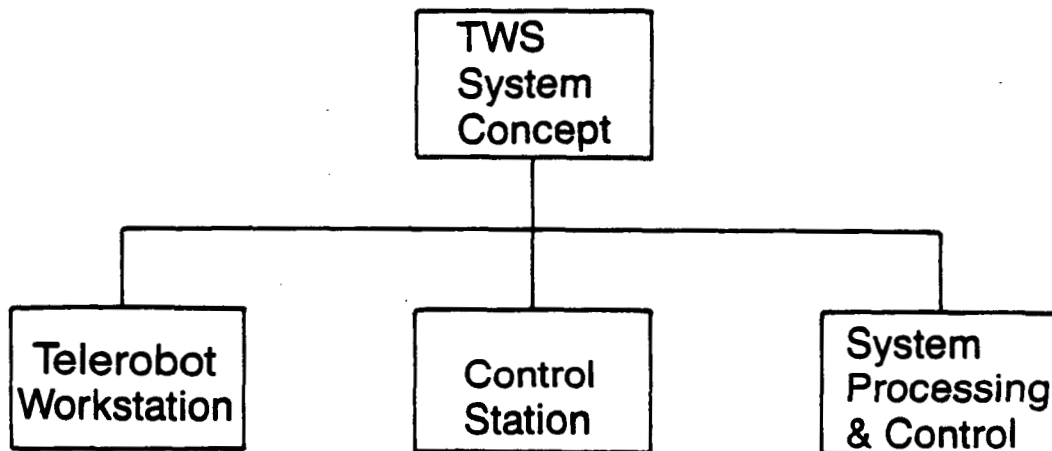

*Figure 3-1 TWS System Concepts*

In addition to the detailed set of requirements developed for TWS in Section 2.0, three basic guidelines were applied to all phases of the system concept development:

- Wherever feasible, existing hardware components were used to maximize the benefits of previously funded work.

- Sufficient capability was included in the initial design concept to allow incorporation of control techniques now reaching maturity in laboratory systems.
- Modularity was stressed to ensure that system evolution can proceed smoothly as time progresses without forcing major redesigns of the existing structure.

### 3.1 TELEROBOT WORK STATION

The telerobot workstation is comprised of the subsystem shown in Figure 3-2. A detailed view of the telerobot is shown in Figure 3-3. Table 3-1 summarizes the results of tradeoffs that were performed concerning workstation elements. The remainder of this section provides a more detailed discussion of selected workstation components.

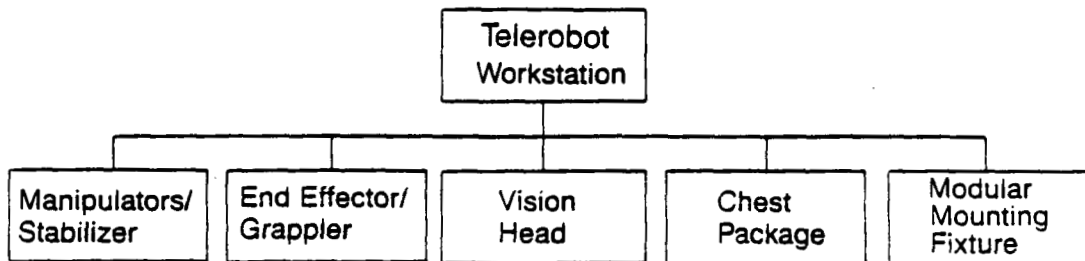

*Figure 3-2 TWS Workstation*

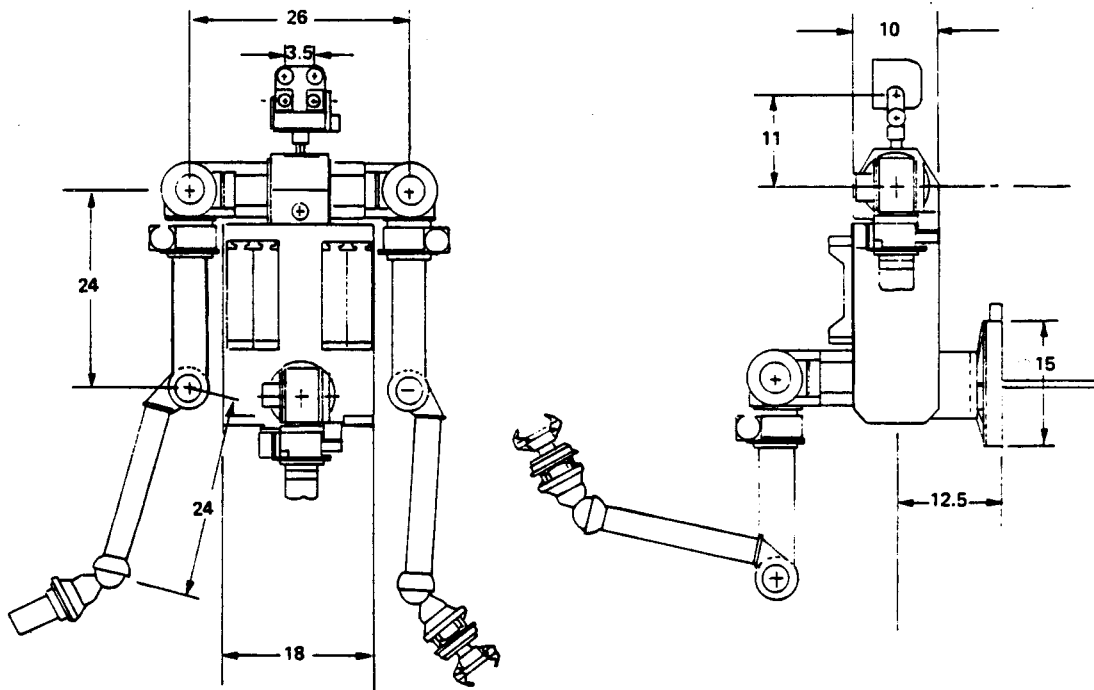

Figure 3-3 TWS System Design

Table 3-1 TWS Workstation—Tradeoff Results

<b>Manipulator Structure</b>				
Degrees of Freedom	< 6	6	7	> 7
Configuration	<input checked="" type="checkbox"/> Anthropomorphic	<input type="checkbox"/> Nonanthropomorphic		
Design Materials	<input checked="" type="checkbox"/> Composites	<input type="checkbox"/> Metal Alloy		
Wrist Design	<input type="checkbox"/> Pitch-Yaw-Roll	<input type="checkbox"/> Yaw-Pitch-Roll	<input checked="" type="checkbox"/> Compact Pitch-Yaw-Roll	
Sizing (Shoulder to Wrist)	2 ft	4 ft	6 ft	8 ft
<b>Stabilizer Structure</b>				
Degrees of Freedom	< 6	6	7	> 7
Number of Stabilizers	0	<input checked="" type="checkbox"/> 1	2	> 2
<b>Manipulator Sensors</b>				
Joint Position	<input type="checkbox"/> Potentiometers	<input checked="" type="checkbox"/> Resolvers	<input type="checkbox"/> Encoders	
Joint Rate	<input checked="" type="checkbox"/> Tachometers	<input type="checkbox"/> Differentiated Position		
<b>Manipulator Drive System</b>				
Joint Actuators	<input type="checkbox"/> Hydraulic	<input type="checkbox"/> a-c Motors	<input checked="" type="checkbox"/> d-c Motors (Brushless)	
Joint Drives	<input checked="" type="checkbox"/> Gear Drive	<input type="checkbox"/> Direct Drive	<input type="checkbox"/> Torque Tubes	
<b>End-Effector Sensors</b>				
Force/Torque	<input type="checkbox"/> Computed Joint	<input type="checkbox"/> Joint Sensors	<input checked="" type="checkbox"/> Wrist Mounted	
Proximity	<input type="checkbox"/> Acoustic	<input type="checkbox"/> Laser	<input checked="" type="checkbox"/> Electro-Optics	
Tactile	<input checked="" type="checkbox"/> Grip Force	<input type="checkbox"/> Touch/Slip	<input type="checkbox"/> Pressure Array	
End-Effector Design	<input type="checkbox"/> Quick Disconnect	<input type="checkbox"/> Opposing Jaw	<input checked="" type="checkbox"/> Opposing Jaw w/Power Takeoff	<input type="checkbox"/> Dexterous
<b>Vision Head</b>				
Pan/Tilt	<input checked="" type="checkbox"/> 2 DOF	<input type="checkbox"/> 3 DOF		
Cameras	<input type="checkbox"/> Vidicon	<input type="checkbox"/> Silicon Target Vidicon	<input checked="" type="checkbox"/> CCD Area	<input type="checkbox"/> SIT Tube
Camera Vendor	<input checked="" type="checkbox"/> Fairchild	<input type="checkbox"/> RCA	<input type="checkbox"/> Sony	<input type="checkbox"/> GE
Tool Design	<input checked="" type="checkbox"/> Self-Contained	<input type="checkbox"/> Umbilical	<input checked="" type="checkbox"/> Power Takeoff	

### 3.1.1 Manipulators and Stabilizer

Early in the design process the decision was made to pursue a dual-arm system and to employ arms that were approximately anthropomorphic with respect to the kinematic configuration. The decision to employ two arms was based both on the issues of redundancy and utility. The presence of a second arm ensures an available backup for the performance of single-arm tasks in the event of a failure of the first arm. If all tasks to be performed were such that only a single arm were required, then the inclusion of a second arm based on redundancy arguments only would be suspect and could only be justified as the result of a complex reliability study. There are, however, many tasks in the TWS mission scenario that benefit from the use of two arms. Two arms allow the range of payloads that can be handled to be increased without significantly increasing task performance time. Two arms are also useful in handling long, slender payloads where vibration is a problem. Finally, with two arms, assembly tasks can be performed without the need for external fixturing. Taken together, these arguments justify the adoption of the dual-arm concept.

It would be ideal if a method existed through which all possible missions could be analyzed and factored into a formula that would yield an optimal kinematic configuration. Although some work has been performed along these lines, such a method does not exist. Therefore, instead of deriving an optimal design, the question really becomes one of selecting an acceptable kinematic configuration from those that are available.

In adhering to the guideline that use should be made of available technology, we elected to proceed with an arm kinematic configuration that is approximately anthropomorphic. Figure 3-4 shows the kinematic configuration of our arm concept. The arm has 7-DOF although the roll in the upper arm is used only for indexing purposes.

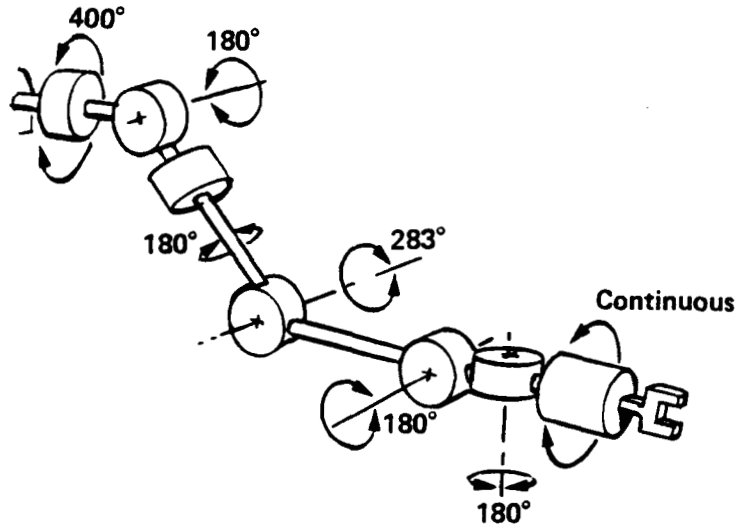

*Figure 3-4 TWS Degrees of Freedom*

A more detailed view of the arm concept is shown in Figure 3-5. This concept represents an evolution of the Protoflight Manipulator Arm (PFMA) developed by Martin Marietta for the MSFC. As specified for the TWS study, the overall length of the arm is approximately four feet. This is a minor point however, as the arm is easily reconfigured by interchanging structural segments located between the drives. The PFMA, for example, was delivered with both two- and four-ft segments and has been used in both configurations.

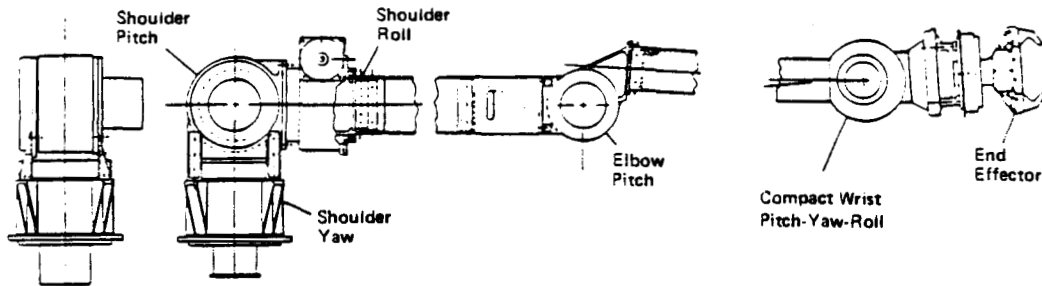

Design Derived From Protoflight Manipulator Arm (PFMA)

- Dexterous, Space-Qualified Design
- Lightweight (~ 115 lbs)
- Backdriveable
- Minimal Drivetrain Backlash and Friction
- Modular Structure
- 7-DOF
- Anthropomorphic
- Compact Stowage

*Figure 3-5 Manipulator/Stabilizer Design*

Figure 3-6 shows the basic drive design used for the shoulder pitch, shoulder yaw, and elbow pitch. This design uses a brushless dc torque motor to drive a dual-path gear train that is preloaded to minimize backlash and friction. The drive design includes integral brakes, resolver, tachometer, and heating elements. The drive design has been used extensively for other space programs and is space qualified.

The upper shoulder roll drive consists of a dc motor driving a worm gear. As described earlier, this drive is used only for indexing purposes. Because of the high effective gear ratio, this drive is not backdriveable and so does not have a brake.

In Part II of this study the decision was made to investigate wrist concepts that would yield a more compact design than provided by the drive arrangement on the original PFMA. After reviewing existing concepts for mechanisms that would provide a coincident 3-DOF capability, the configuration shown in Figure 3-7 was selected as the primary candidate. This design was developed and prototyped by Mark Rosheim of Ross-Hime designs for Martin Marietta. Figure 3-7 also shows the mechanical structure as well as actuation and packaging concepts.

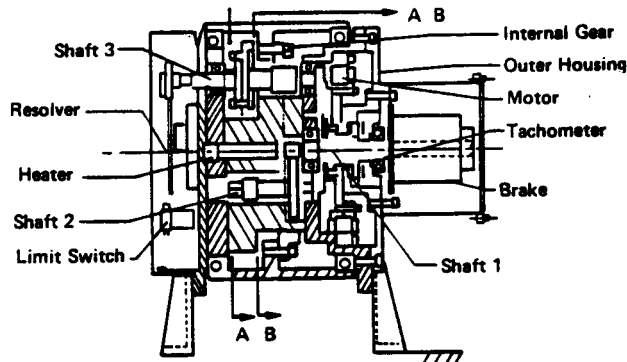

- Actuators
  - dc Brushless Motors
  - Fail-Safe Brakes
- Gear Drives—Improved P-FMA Design
  - Martin Marietta Preloaded Design to Eliminate Backlash
  - Backdriveable
  - Minimal Friction
  - Space-Qualified Design
- Sensors
  - Resolvers Each Joint
  - Tachometers Each Joint
- Thermal
  - TRASYS and MITAS II Thermal Simulations Performed
  - Cold-Bias Design
  - Tape Heaters Each Joint
- Auxiliary B&W CCD Cameras Mounted on Each Wrist

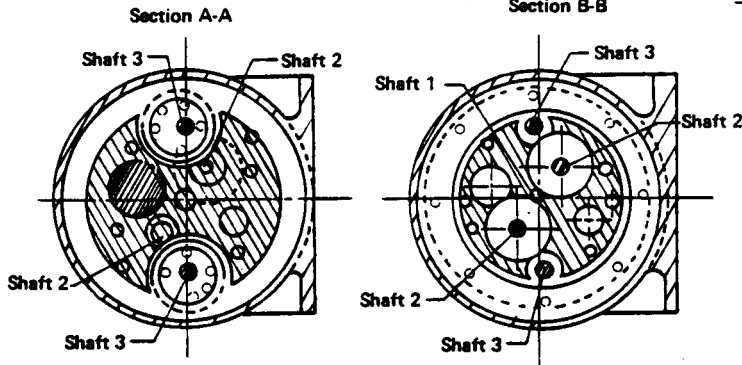

Figure 3-6 Manipulator/Stabilizer Design Detail

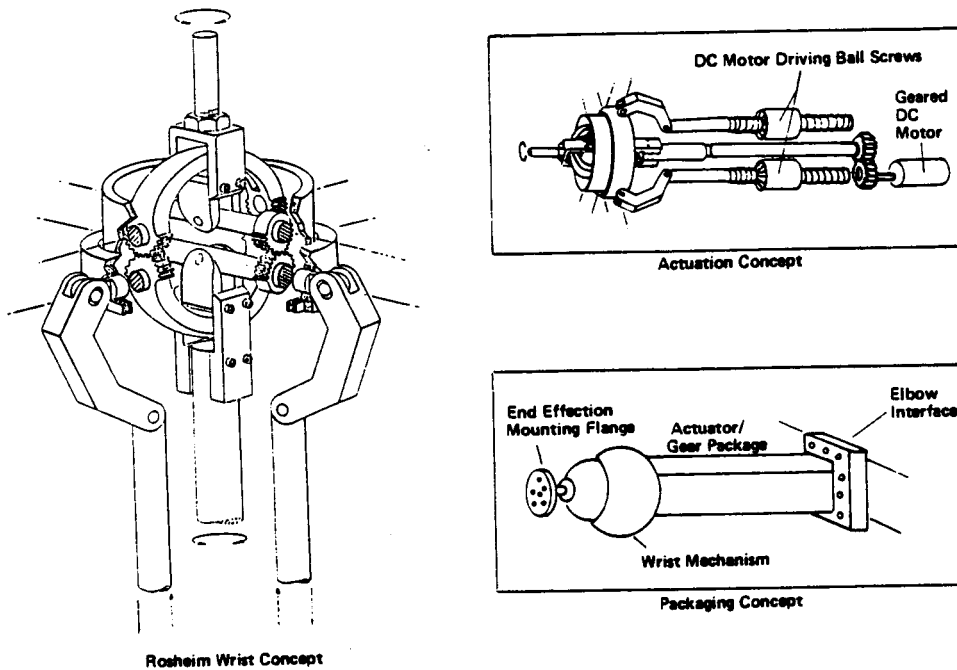
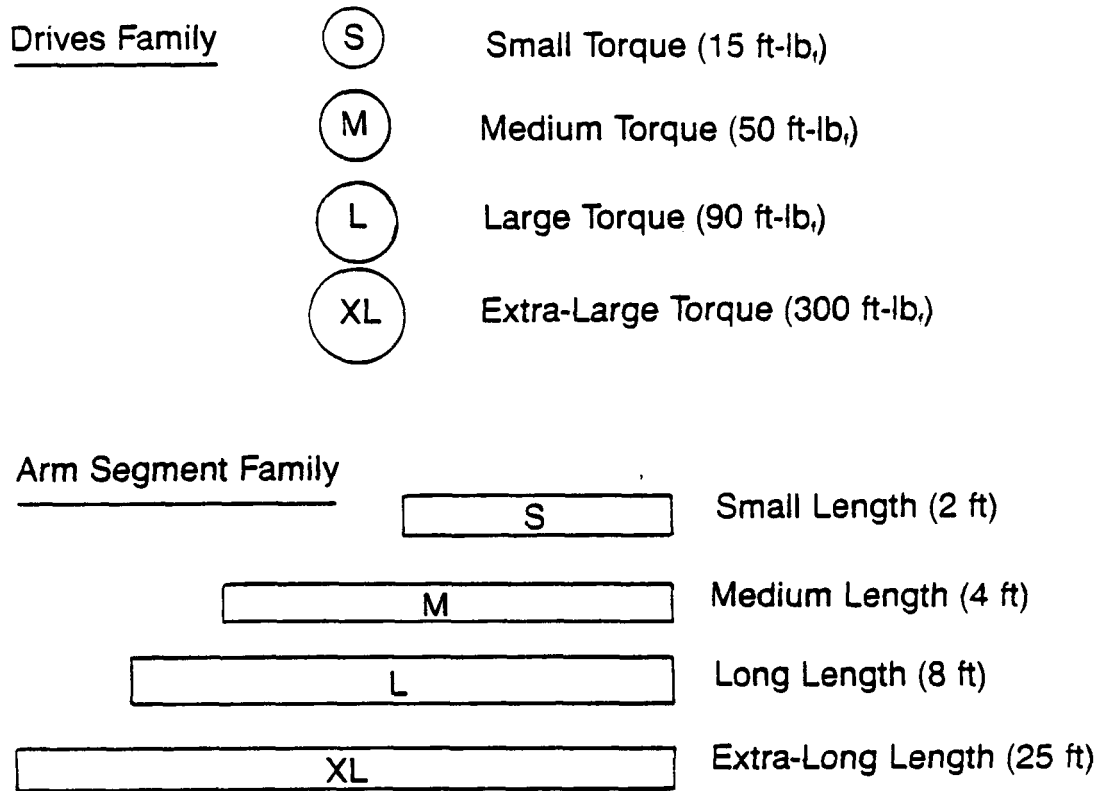

Figure 3-7 Compact Wrist Concept

A concept arising from the Part II study effort not discussed in the Part I study involves a modular arm concept illustrated in Figure 3-8.



*Figure 3-8 Reconfigurable Arm Family*

Using this concept, a component family would be established consisting of both drives and arm segments. Arm configurations could be tailored to specific missions to be performed and assembled onorbit.

In Part I of this study, a limited DOF stabilizer concept had been recommended. In the interim this issue has been reviewed and it is now recommended that the stabilizer design duplicate that of the primary manipulators. This provides the 7-DOF capability for the stabilizer system as well as further increasing overall system redundancy.

### 3.1.2 End Effector/Grappler

The baseline design concepts for both the manipulator gripper and stabilizer grappler are shown in Figure 3-9. The manipulator



end-effector design employs a parallel jaw gripper with intermeshing jaws. The Jet Propulsion Laboratory (JPL) "Smart" end-effector design appears to meet all requirements that were established. This design includes an integral six-axis force/torque sensor and also provides the capability for measuring finger clamping force. Proximity sensing will be provided through the use of electro-optical sensors. While the TWS will have to employ special tools for many operations, it is not clear at this time whether emphasis should be placed on a "quick change" capability or a more complicated gripper configuration. Using a quick change system, the parallel jaw gripper would be one of many possible tool choices. However, it is also possible to design an electrical interface in conjunction with a parallel jaw configuration such that electrical connector mating is performed when the tool is grasped.

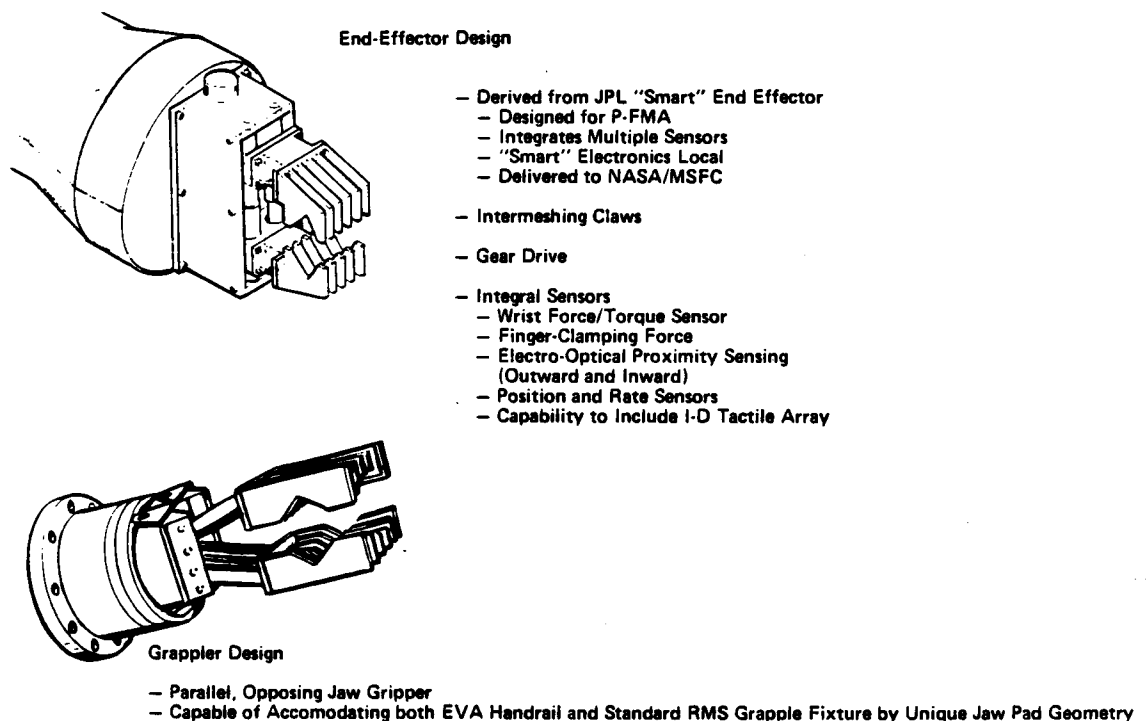

**Figure 3-9 End-Effector/Grapppler Design**

The grapppler design employs a parallel jaw gripper that has the capability of accommodating both EVA handrail as well as the standard RMS grapppling fixture through a unique jaw geometry. Because of the more well-defined nature of the missions to be performed using the grapppler, it is not felt that it would have to retain the full sensing capabilities of the general manipulator end effector.

### 3.1.3 Vision Head

Our concept for a vision head design is shown in Figure 3-10. This system provides the capability for stereo vision using two Fairchild black and white charge-coupled device (CCD) cameras. This system has the following features:

- Auto iris (manual override),
- Manual focus,
- Manual zoom,
- 1- to 6-ft work distance accommodation.

- Lighting
  - Two Incandescent Tungsten-Halogen Lamps
  - 5° Off-camera Axis
  - Individually Variable Intensity
  - Up to 40 ft-Lamberts on Working Surface
- Pan/Tilt
  - 2-DOF Articulation
  - Tilt:  $\pm 180^\circ$  from Vertical
  - Pan:  $\pm 270^\circ$  from Forward
  - 0.5 rad/s Maximum Rate
  - 0.1 rad/s Maximum Acceleration
- Stereo Camera Pair
  - Fairchild B&W CCD Cameras
  - Auto Iris (Manual Override)
  - Manual Focus
  - Manual Zoom
  - 1 to 6 ft Work Distance Accommodation

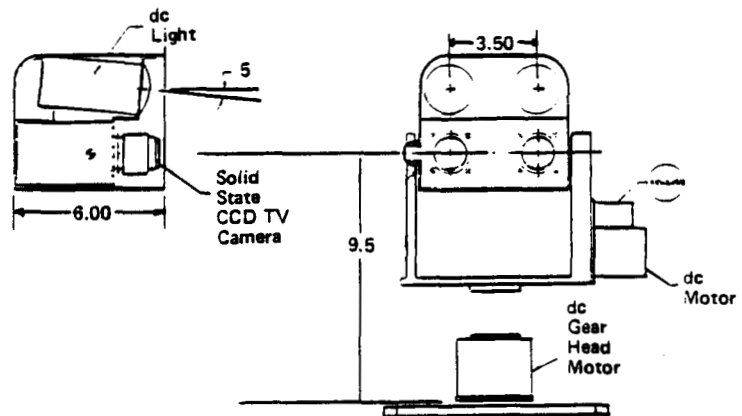

*Figure 3-10 Vision Head Design*

The vision head provides the capability for pan and tilt action. Allowable tilt is  $\pm 180^\circ$  from vertical. Allowable pan is  $\pm 270^\circ$  from forward. Allowable rates in each axis are .5 rad/s.

The decision to recommend a 2-DOF head motion capability rather than 3-DOF was made based on the fact there appeared to be no firm justification for the added degree-of-freedom. A 3-DOF vision head system is in the process of fabrication at Martin Marietta to explore this issue.

#### 3.1.4 Chest Package and Modular Mounting Fixture

In Part I of this study, a single structure was proposed that housed the electronics and processing, provided a base for the arms and stabilizer, and served as a mount for the RMS grapping fixture. In Part II, a wider range of mission scenarios were considered, including the OMV. In examining the requirement to provide the capability for interfacing with a wider range of devices, the concept from Part I of the study has evolved to that shown in Figure 3-11. In this concept the single structure has been replaced by two structures: a chest package that contains the arm/stabilizer/sensor electronics and processing, and a "modular mounting fixture" that is designed to accommodate a specific interface such as the RMS or OMV. The rationale behind this change was the fact that it was too difficult to design a single unit that would easily accommodate all deployment scenarios.

#### 3.1.5 Telerobot Workstation Summary

This section has detailed a concept for a telerobot workstation. Mature technology has been employed in all aspects of the design, resulting in a system that has no major gaps in terms of feasibility. Weight and power for our concept are summarized in Table 3.2.

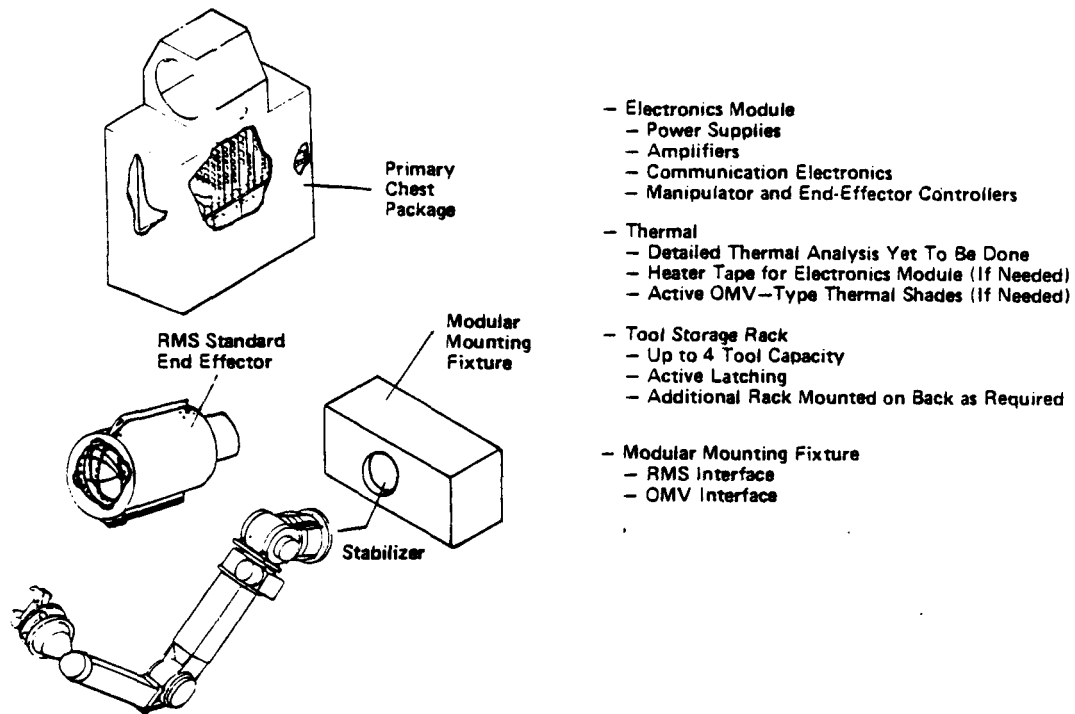

- Electronics Module
  - Power Supplies
  - Amplifiers
  - Communication Electronics
  - Manipulator and End-Effector Controllers
- Thermal
  - Detailed Thermal Analysis Yet To Be Done
  - Heater Tape for Electronics Module (If Needed)
  - Active OMV-Type Thermal Shades (If Needed)
- Tool Storage Rack
  - Up to 4 Tool Capacity
  - Active Latching
  - Additional Rack Mounted on Back as Required
- Modular Mounting Fixture
  - RMS Interface
  - OMV Interface

Figure 3-11 Chest Package

Table 3-2 Workstation Weight and Power

- Weight Budget				- Power Budget	
Component	Qty	Single Weight	Total		Average Power, Watts
<b>Head System</b>					
Vision Assembly	1	5 lb	15 lb		
Pan-Tilt Gimbal	1	10 lb			
<b>Body System (Structure &amp; Electronics)</b>	1	---	150 lb		
<b>Arm System</b>	3	115 lb	345 lb		
Shoulder & Upper Arm		52 lb			
Elbow & Lower Arm		74 lb			
Wrist		21 lb			
End Effector		8 lb			
Wire Harness & Bracketry		22 lb			
<b>Tool Rack (Rack &amp; Two Tools)</b>	2	15 lb	30 lb		
<b>Modular Mounting Fixture</b>	1	---	66 lb		
<b>RMS Interface Yoke Assembly</b>	1	---	74 lb		
		Misc:	35 lb		
		<b>Total Wt:</b>	<b>600 lb</b>		

- Manipulator Arms (2)	500
- Stabilizer*	(250)
- End Effectors	50
- Pan/Tilt	50
- Cameras	30
- Lighting	200
- Heaters	100
- Processors	150
- Other Electronics	100
<b>1180 Total Watts</b>	
*Stabilizer Operates Exclusively As One of the Manipulators	

## 3.2 CONTROL STATION

### 3.2.1 Control Station Design Objectives

In Part I of the TWS contract, a control station was developed that used the Space Shuttle's aft flight deck Panels L10 and L11. This location was chosen over several other possibilities, including the mid-flight deck and the Space Lab module, because of the proximity to the RMS controls and the ability to visually confirm operations. However, as an experimental system, use of this panel space would be extremely expensive. To reduce shuttle interface costs and to improve the modularity of the system, a primary objective of the TWS Part II study was to develop a control station concept that could be stowed in a single mid-deck stowage locker and then deployed in the aft flight deck during the mission. This objective required a drastic reduction in size, weight, and power consumption of the original concept. However, these reductions in size could not come at the expense of operational capabilities. The compact control station still required all necessary operational and safety information while providing a transparent interface for the operator to control a dual-arm telerobot with stabilizer. The resulting concept meeting these objectives is shown in Figure 3-12.

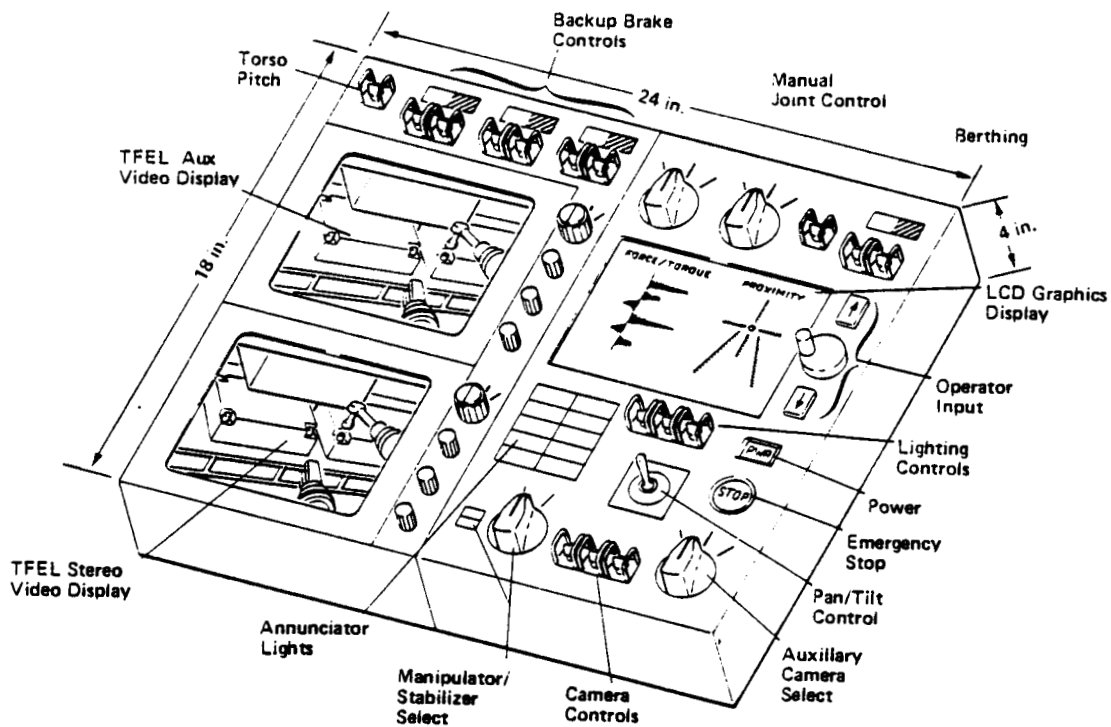

Figure 3-12 Control Station Layout

### 3.2.2 Tradeoff Results Summary

Table 3-3 shows the primary tradeoff results in developing the control station concept for the TWS study. A brief discussion of these results is made here.

The only viable concept for coordinated control of multiple arms in a space-based environment is the use of 6-DOF hand controllers. Exoskeletal or replica master controllers are ruled out because of the severe weight and volume constraints imposed on space-based equipment. Of the non-replica master controller designs considered to date, the 6-DOF joystick design has been chosen for its relative freedom from cross-coupling between axes and its extremely compact design.

**Table 3-3 TWS Control Station Tradeoff Results**

Hand Controller					
Configuration	Replica Master	Nonreplica Master	Exoskeleton	3-DOF Joysticks	6-DOF Joysticks
Available Modes	Rate	Position	Indexed Position	Force Feedback	
Primary Video Display					
Configuration	Mono	Visor-Mounted Stereo Shutter	Fresnel Stereo	Onscreen Stereo Stereo Shutter	Reflective Stereo
Format	B&W	Color			
Auxiliary Displays	Mono Video	Stereo Video	HUD-Type Graphics	Standalone Graphics	
Display Technology					
Stereo	CRT	TFEL	Plasma	LCD	
Mono	CRT	TFEL	Plasma	LCD	
Graphics	CRT	TFEL	Plasma	LCD	
Other Controls & Displays					
Operator Input	Touchscreen	Keyboard	Trackball	Thumbwheel	Mouse
Pan/Tilt Control	Joystick	Toggle Switches			
Video Display Control	Rotary Switch	MFD			
Manipulator Select	Rotary Switch	Toggle Switch	MFD		
Camera Select	Rotary Switch	MFD	MFD		
Mode Select	Rotary Switch	MFD			
Mode Indicators	Panel Lights	MFD			
Limit Set	Rotary Dials	MFD			
Auto Sequence Select	Rotary Switch	MFD			
Graphics Select	Rotary Switch	Toggle	MFD		
Backup Joint Control	Individual Toggles	Rotary/Toggle			
Control Station Location	Aft Flight Deck	Mid Deck	Space Lab		

Using a compact 6-DOF joystick hand controller, it is impossible to present true position control because of the limited travel available. Although a rate control mode is preferable for large slewing motions, it is highly desirable to have an indexed position mode available for close proximity operations. Bilateral force reflection has been the predominant method of providing the operator with information about the forces the telerobot imparts on the environment. However, serious questions arise concerning the use of bilateral force reflection in space-based systems, especially in systems that have significant time delay. Other schemes of controlling environmental interaction, to be discussed later in this report, may have advantages over bilateral force reflection. For this reason, bilateral force reflection (force feedback to the operator) has not been selected as a mode that is required for the TWS concept, although it has not been eliminated from consideration.

Studies have repeatedly found that stereo vision improves depth perception, makes viewing angles less important, and significantly decreases teleoperator task times. For these reasons, a stereo video display has been chosen as the operator's primary display. However, the design of this stereo display will be depend upon near-term developments in the onscreen polarizing shutter technology. Further discussion comparing the two candidate stereo display systems is presented in Section 3.2.4.

A black and white format was chosen over a color format for the video displays. Numerous factors influenced this decision, the most important of these being the lower bandwidth requirements for transmission of black and white images, the limited color capabilities of flat panel display technologies, the low color content typical of video images in space, and the lack of a firm requirement for displaying video images in color.

Two forms of auxiliary displays were chosen to be included in the control station. First, a black and white mono video display is needed to back up the primary stereo display and to provide a means of displaying auxiliary images, such as those available from the telerobot's wrist-mounted cameras. Second, a graphics display is needed to present vital status and sensory information. This display was chosen to be a standalone graphics display. Although the Part I study recommended that this information also be available for display over the video images on the primary and auxiliary displays, processor space constraints may preclude this option.

To meet the size reduction objective of the Part II study, the cathode ray tubes (CRT) used in the Part I control station concept had to be replaced with flat panel display technology. There are several viable flat screen technologies available that meet the TWS requirements, and near-term development promises even greater capabilities. The thin film electroluminescent (TFEL) display technology was selected for the video displays because of its compatibility with video signals and its



availability in relatively large formats. The liquid crystal display (LCD) was selected for the graphics display because of its extremely low power consumption and its simple computer interface. A more detailed comparison of flat screen technologies is presented in Section 3.2.3.

Most of the remaining controls and displays are shown in the tradeoff table (Table 3-3). The determining factors in selecting the particular controls and displays for the various functions were (1) minimization of panel space and (2) use of familiar controls and displays where possible for critical functions. As a result, noncritical functions and options are selected from menus on the multifunction display (MFD). Safety-related and operational controls are similar in form and function to RMS controls.

The last item listed in the tradeoff table is the control station location. The only feasible location onboard the shuttle for control station operations is the aft flight deck. Because the mobility of TWS is to be provided by the RMS arm, the TWS controls must be located near the RMS controls in the aft flight deck. Additionally, the aft flight deck provides the means to visually confirm TWS operations. Finally, standard payload wiring and cooling are available in the aft flight deck.

### 3.2.3 Flat Display Technology Comparison

The flat-screen display technologies evaluated for this study were the vacuum florescent display (VFD), the flat-screen CRT, the TFEL display, the LCD, the AC plasma display panel (AC PDP), and the magneto-optic display (MOD). Figure 3-13 shows the basic construction of these various displays.

The vacuum fluorescent display is an emissive display technology, as opposed to a transmissive display technology. It has some very attractive properties, including good brightness, high resolution, and very low power consumption. However, because the device is fabricated directly onto a complementary metal-oxide semiconductor (CMOS) chip, its applicability is currently limited to small sizes.

Prototype flat-screen CRT displays have recently been developed to replace the conventional CRT in certain applications. Using a unique matrix drive and deflection system, a prototype flat CRT display has been produced by Matsushita with a 10-in. diagonal screen and with a depth of less than 4 in.. It has the advantages of conventional CRTs in terms of high resolution, high-contrast ratio, and high brightness. The flat CRT also has 64 steps in gray scale, as compared to 16 steps in most other flat-screen technologies. However, the flat CRT retains the disadvantages in weight and power consumption of the conventional CRT.

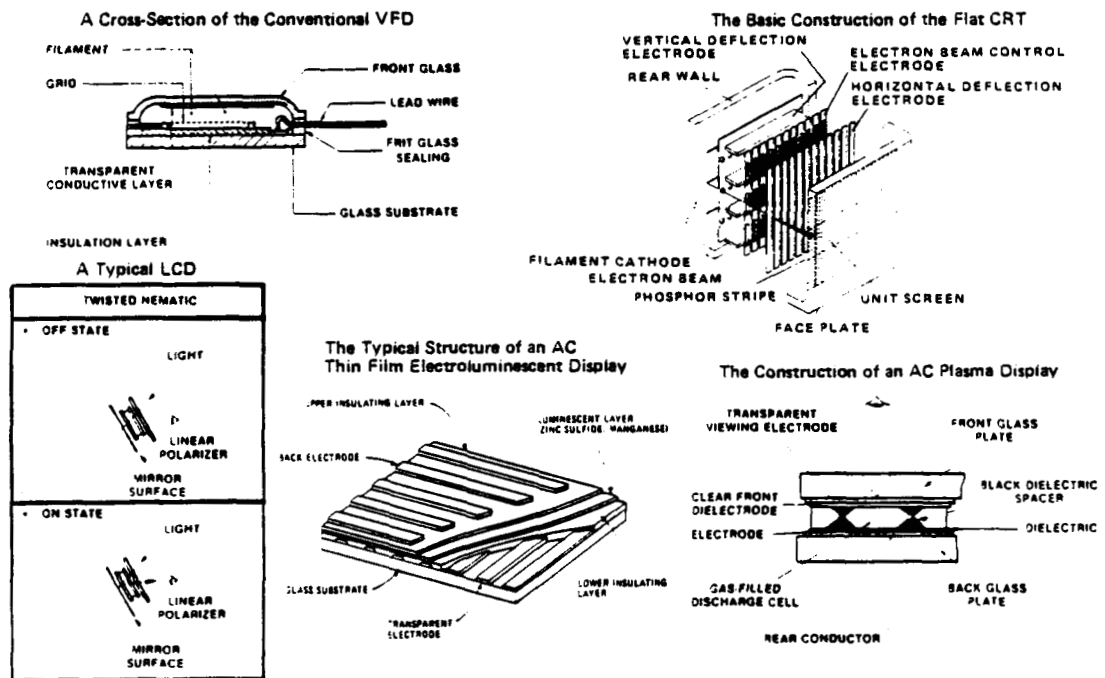

Figure 3-13 Candidate Flat Screen Technologies

Thin film electroluminescent displays, also an emissive display technology are now commercially available in sizes up to 4x8 inches that are only 0.55 in. thick. Custom displays are available in sizes up to 12x12 in. Being entirely solid state, they are extremely rugged and lightweight. TFEL displays can handle the update rates required for display of video information and can display full red, green, blue (RGB) color. They consume less power than any comparable emissive display, and require lower voltage levels than CRTs or AC plasma panels. Perhaps the only major concern in using TFEL displays is the complex electronics interface needed to drive them. However, off-the-shelf display drivers are now available that drastically simplify the display interface.

Recent developments in LCDs make them the most promising for future applications. Many corporations and universities, both foreign and domestic, are actively researching LCDs because of huge potential markets in commercial television and computer displays. This intense concentration of effort should soon produce LCD technology for a wide range of applications.

Because of their inability to display images at video rates, large-area LCD displays are currently available only for computer displays. Commercial sizes of graphics/alpha-numeric displays range up to 8x10 inches while having a thickness of less than 0.5 inches. Because LCDs are transmissive, they consume very little power (on the order of 100 mW for a reflective-type display). This is particularly attractive for space applications. LCDs have the additional advantage of requiring very simple low-voltage interface electronics. They are by far the simplest of the flat panel displays to control.

The AC plasma display, an emissive display technology, is generally considered to be the primary competitor to the TFEL display. AC plasma displays are available in many sizes up to 28x28 inches. However, if size requirements do not dictate anything larger than 12x12 inches, advantage can be taken of the TFEL display's superior features. AC

plasma panels are much heavier, consume much more power, and have lower brightness and contrast ratio than TFEL displays. Additionally, they are difficult, at best, to use with video signals.

Finally, the magneto-optic display has been included in this discussion for completeness. The MOD, similar to the LCD, is a transmissive display. Unlike the LCD however, the MOD has very low transmissivity and as a result would be a poor choice if high brightness is required. It is clear there are better options available than the MOD for this application.

The performance characteristics for these display technologies are compared in Table 3-4. The TFEL display has been chosen to provide the display of video information because of its compatibility with video frame rates, its compactness, and its relatively high performance. The LCD display has been chosen to provide the display of computer graphics/alpha-numeric information because of its compactness, its low power consumption, and its ease of interfacing. Replacing the displays in the Part I study concept with these flat screen display technologies reduces the size and weight of the control station displays by up to 95%. In addition, substantial savings in power consumption is also realized.

**Table 3-4 Flat Screen Technology Comparison**

Candidate Flat Panel Technologies	Contrast Ratio	Resolution, $\mu\text{m}$	Response Time	Power, W	Area Brightness	Viewing Area, in.	Thickness, in.	Viewing Angle, deg	Efficiency, $\mu\text{W/W}$	Grey Scale	Color	Life Expectancy	Weight, lbs	Video Compatibility	Drive Electronics
VFD	30:1	50	280 ns	0.20	35 FL				0.5-2	16	Yes				Matrix Addressable
Flat CRT	50:1	(270 TV Lines)		70	70 FL	7x7	<3.0		5	64	Yes	10,000 hrs		Yes	Various
TFEL	Up to 100:1	250	1-10 $\mu\text{s}$	18-40	110 FL	Up to 12x12 (cstm)	<1.0	$\pm 70$	0.5	16	Ltd	30,000 hrs	~5	Yes	Complex, High Voltage
LCD	Up to 40:1	88	50-500 ms	5-15 (incl back-light)	180 FL	Up to 5x8	<0.5	$\pm 40$	3-4	8	Yes (Dvlp)		<1	Yes (Dvlp)	Simplest, Low Voltage
AC Plasma	25:1	300	10 $\mu\text{s}$	40-200	55 FL	Up to 28x28	<6.0	$\pm 35$	1	8	Very Ltd	20,000 hrs	>25	No	Complex, High Voltage
MOD	20:1	50	200 ms	25-75 (incl back-light)	10 FL					16					

### 3.2.4 Stereo Display Concepts

The recent development of high-speed LCD polarizing shutters has made the concept of a compact, high-performance stereo video system possible. A concept for using this shutter technology is shown in Figure 3-14. In this concept, left and right camera images are alternately displayed on the TFEL monitor. A passive linear polarizer is placed over the monitor to produce polarized images. An active LCD, which is synchronized to the display of left and right camera images, is placed over the passive polarizer. When the left image is displayed, the LCD shutter is placed into "off" state and simply passes the polarized image unchanged. When the right image is displayed, the LCD shutter is placed in the "on" state and not only passes the polarized image, but rotates the polarization 90°. Thus, the LCD shutter acts as a high-speed optical switch passing the left and right camera images, but making the polarization of these two images 90° out

of phase. If the operator wears passive polarized glasses where the polarization of the left lens is oriented in the same direction as the polarization of the left image and the polarization of the right lens is oriented in the same direction as the polarization of the right image, he will see the original image in stereo with the same image disparity as the stereo camera pair.

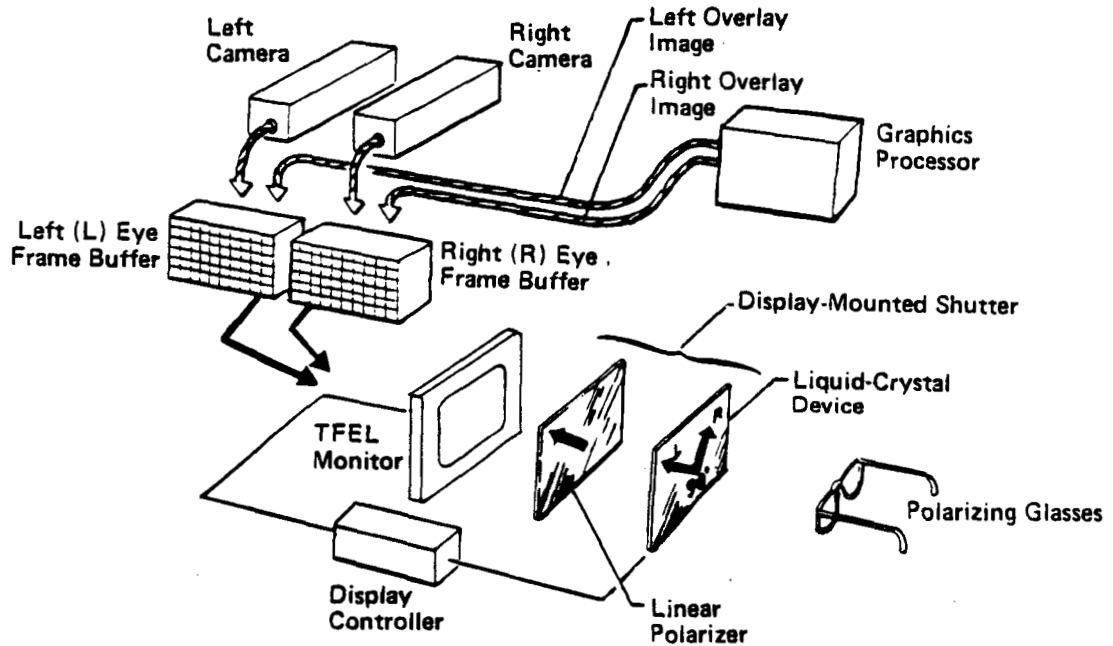

*Figure 3-14 Stereo Display System*

To obtain a flicker-free stereo image, both the left and right images must be displayed and viewed at a rate of 60 Hz. This means the monitor must be capable of displaying images at 120 Hz. Because of the interlacing schemes used in conventional CRT monitors, it is not difficult to achieve this level of performance. However, the compatibility of the TFEL display using these frame rates has yet to be demonstrated. A prototype stereo display system using both the LCD polarizing shutter and the TFEL display needs to be built to assure compatibility.

In the event that TFEL displays are not capable of achieving the higher frame rates needed to provide a flicker-free stereo image, the reflective stereo display is a viable option. Although not considered in the Part I study because of the large volume requirements using conventional CRTs, a deployable reflective display using TFEL monitors could meet the sizing requirements of the TWS Control Station. Figure 3-15 shows a reflective stereo display concept using TFEL monitors. The reflective display works on the same principle as the shutter-based system in that it produces an image that is a combination of the left and right images polarized 90° out of phase. Although clearly not as desirable as the shutter-based system because of the volume required for operation, the reflective system provides a high-resolution, flicker-free stereo image with the monitors operating at standard video update rates. This system has the same advantages of the the shutter-based system in that the operator wears only passive polarized glasses and his movements are virtually unrestricted.

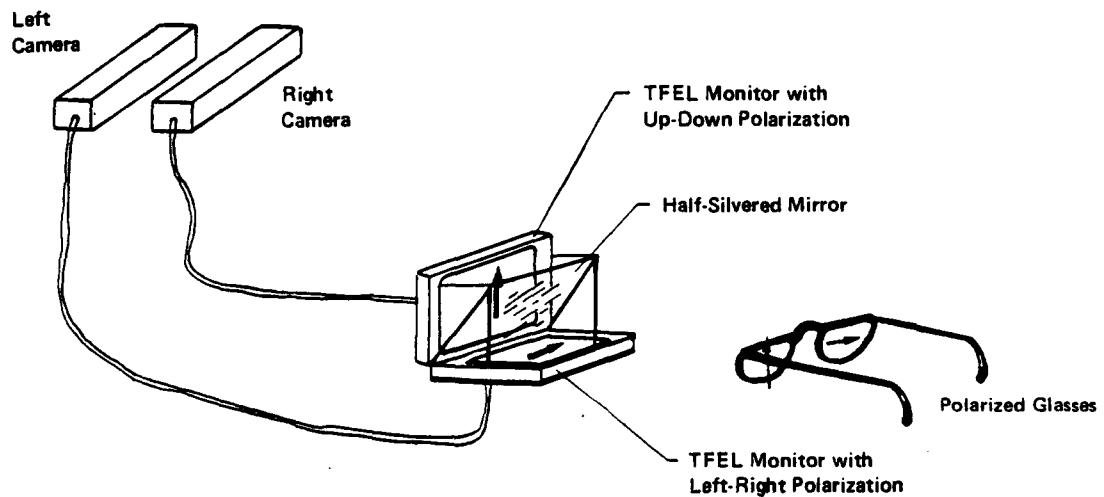

*Figure 3-15 Reflective Stereo Display System*

### 3.2.5 Hand Controller Design

The hand controller design used in the TWS control station concept, shown in Figure 3-16, is derived from the compact, 6-DOF,

force-reflecting hand controller (FRHC) designed and built by Martin Marietta under internal funding. The configuration of this prototype hand controller has three translational joints each with 1.0 in. of travel and three rotational joints each with 30° of travel. Perhaps the best features of this design are its relative freedom from cross-coupling, particularly between the rotational and translational joints, and its compact design. Although the capability for force feedback to the operator has not been firmly established as a requirement for TWS, this prototype does have force reflection capability. The linear motors in the translational degrees of freedom provide up to 5 lbs of force in each direction and the rotary motors in the rotational degrees of freedom provide up to 10 in.-lbs of moment in each direction.

Although it is clear the interaction forces between the telerobot and the environment must be controlled, it is not clear that force feedback to the operator via a FRHC is the best method of controlling these forces. Substantial penalties in terms of size, weight, and power consumption are realized by using FRHCs rather than non-FRHCs. In addition to the size and weight of twelve motors (six motors for each of the two 6-DOF hand controllers), there is a substantial amount of support equipment required. This includes twelve amplifiers plus digital/analog converters and supporting analog electronics. In addition, prolonged operation with an FRHC tends to fatigue operators. In space operations, it will probably be necessary to restrain the operators to be able to use force reflection. Finally, in systems where substantial communication or computational time delays exist, it is very difficult for the operator to maintain system stability using force feedback. For these reasons, it seems premature to require the capability of bilateral force reflection without thoroughly examining alternate schemes of controlling telerobot/environment interaction forces.



Some preliminary work has been performed in this area and will be discussed in more detail in the System Processing section.

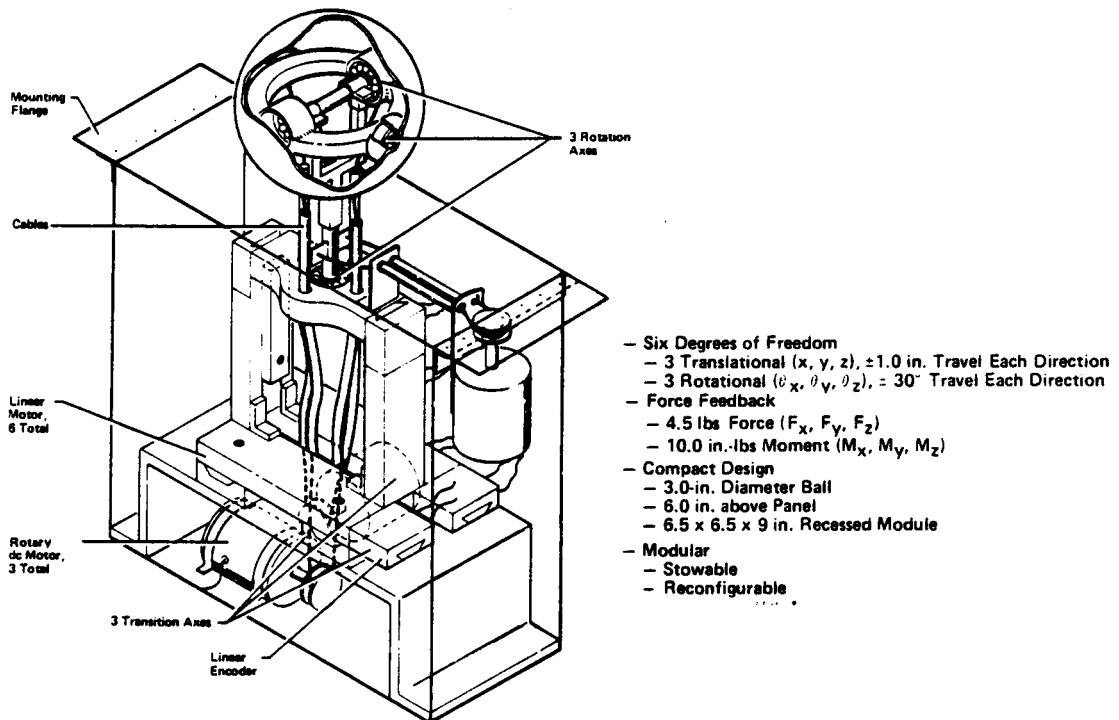

*Figure 3-16 Hand Controller Design*

Whether or not the hand controller design will have the capability of force reflection, it will be built as a modular component. Rather than making the hand controller an integral part of the control station, the TWS hand controller concept is a standalone unit that can be stowed separately and then connected to the control station when deployed. Therefore, the hand controller unit itself will contain the majority of its support electronics. This allows the design of the control station to be done independently of the hand controller design, and requires only that interface scars be designed into the control station to allow the use of an FRHC if required.

### 3.2.6 Multifunction Display

Multifunctional displays have been used for years in specialized applications, such as high-performance aircraft, where panel space is extremely limited. Similarly in the TWS control station design, there are many controls and options to be presented to the human operator, but very little panel space for placement of switches and selection dials. For this reason, a multifunction display will be used for input of noncritical commands and display of noncritical information. The commands available on the multifunction display include selection of modes (rate mode, position mode, high gain) selection of reference frames, selection of force/velocity limits, and selection of graphics displays. The format for the multifunction display is to be menu-driven. To eliminate the need for a keypad, selections will be made using a track ball (or thumbwheel) and enter keys. This format provides a very simple interface between the data entry device and the control station input/output (I/O) processor.

### 3.2.7 Control Station Stowage and Deployment

A concept for the TWS control station has been developed in the Part II study that can be stored in a single mid-deck stowage locker (measuring approximately 17.31x9.95x20.32 in.). This includes not only displays, but the processing components and two non-FRHCs. If FRHCs are used, they would have to be stored separately. The stowage of the control station and hand controllers is shown in Figure 3-17. The control panel itself measures approximately 12x18x9 in. in the stowed configuration, and simply unfolds to provide 24x18 in. of usable panel space. This panel can easily be placed over existing payload panels in the aft flight deck without affecting other payloads. The only interface requirement is that the control station have access to the standard payload wiring in the aft flight deck. The deployed control station is shown in Figure 3-18.

ORIGINAL PAGE IS  
OF POOR QUALITY

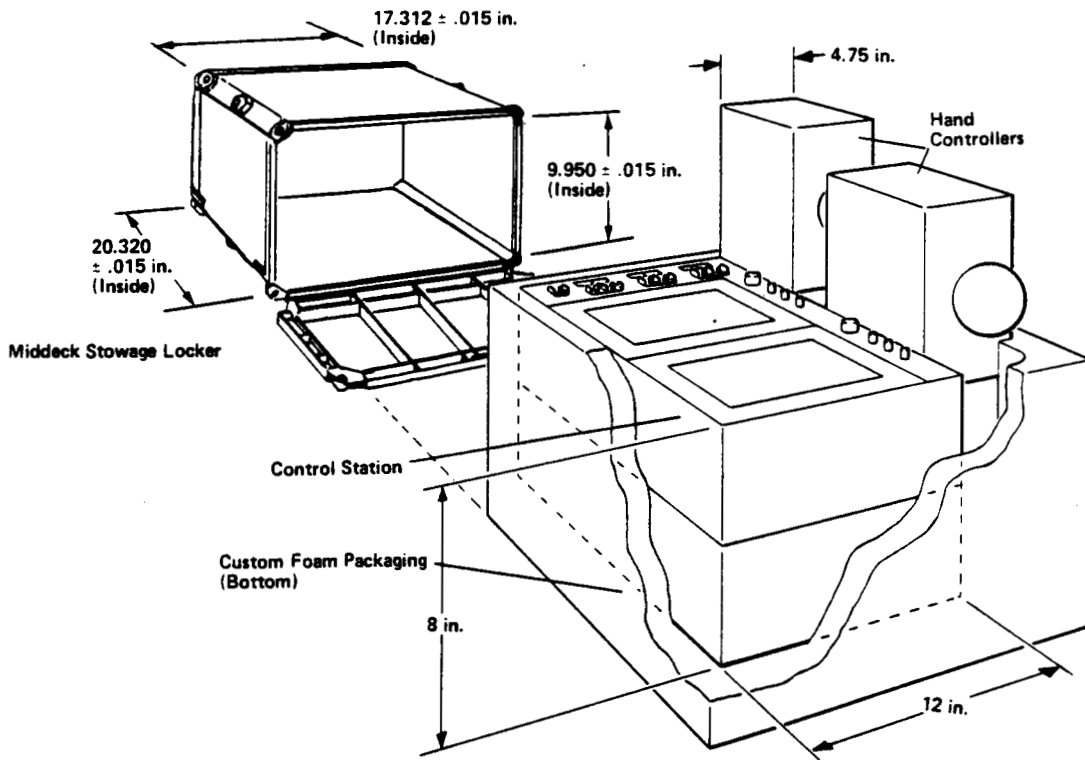

Figure 3-17 Stowage of Control Station

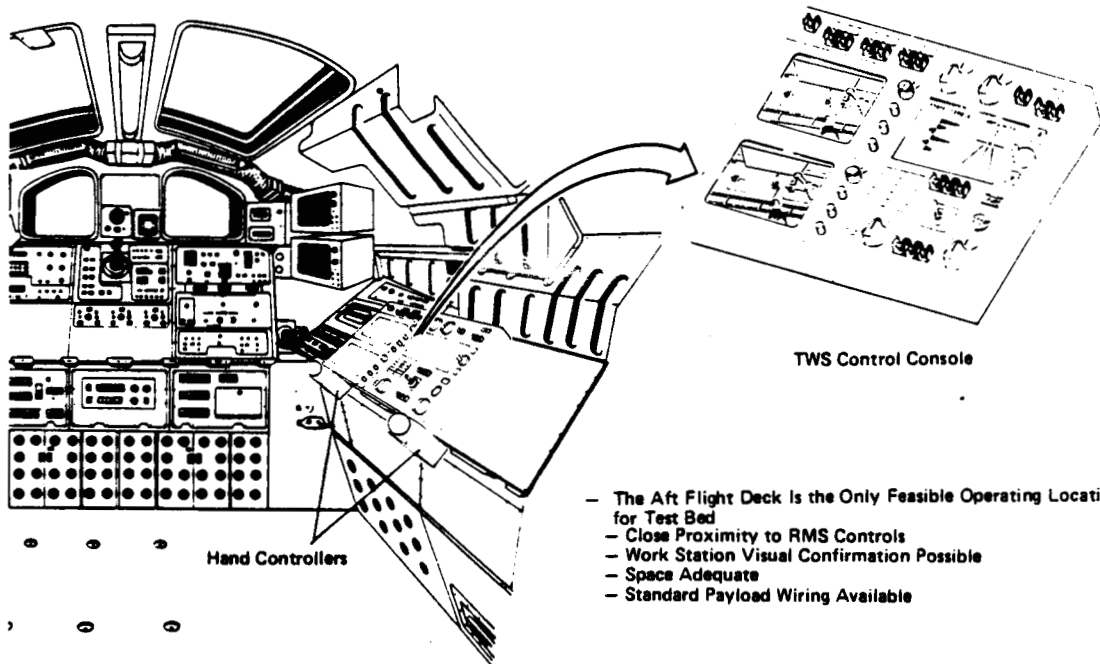

Figure 3-18 Control Station Deployed Location

The resulting operator interface includes two TFEL video displays, one of which is a stereoscopic display. Also included in the operator interface is an LCD graphics display that can display a wide variety of sensory data. All required safety and backup controls are provided with the critical interfaces made through analog switches. A digital interface is provided through the use of a multifunction display that presents a wide range of options and operating parameters to the operator. Control of the telerobots manipulators is provided by two 6-DOF hand controllers, the inputs of which can be interpreted as position commands, rate commands, or force commands. The resulting control station concept provides a versatile and quite extensive teleoperator control interface in a very compact package.

### 3.3 PROCESSING AND CONTROL

This section describes the processing system concept developed for the TWS as well as associated control system capabilities. The processing system concept presented here has been motivated by two primary factors--the requirements developed for the TWS and an extensive background in the implementation of real-time control systems.

The structure presented here reflects the "lessons learned" from Phase I and II of the Defense Advanced Research Projects Agency (DARPA)/Air Force Wright Aeronautical Laboratory (AFWAL) Intelligent Task Automation (ITA) contract, the Intelligent Robotic System Study (IRSS) contract with MSFC, and a number of laboratory systems. Our proposed processing structure provides not only significant near-term system capabilities, but also supports system expansion for more advanced supervisory and autonomous control functions.

As in the case of the processing architecture, our proposed manipulator control system implementation reflects a significant base of implementation experience. A key feature of our control system

structure is the use of measured forces and torques at the manipulator end effectors as feedback signals into the control loops. This provides the capability for "force" or "compliant" control. Our recommendation that this capability be included as part of the baseline system stems from the encouraging results we have seen in our laboratories over the past year for both single and dual-arm implementations.

### 3.3.1 Processing System

Figure 3-19 shows a top-level breakdown of our processing system structure. Processing has been partitioned into two main areas: control station and telerobot workstation. The most significant feature of this system is that all processing necessary for manipulator, stabilizer, and sensor system control is located at the telerobot. The decision to pursue this approach was based on the assumption that later mission scenarios for the TWS might require control from the ground. This implies large communication time delays and requires that real-time manipulator control be located at the worksite.

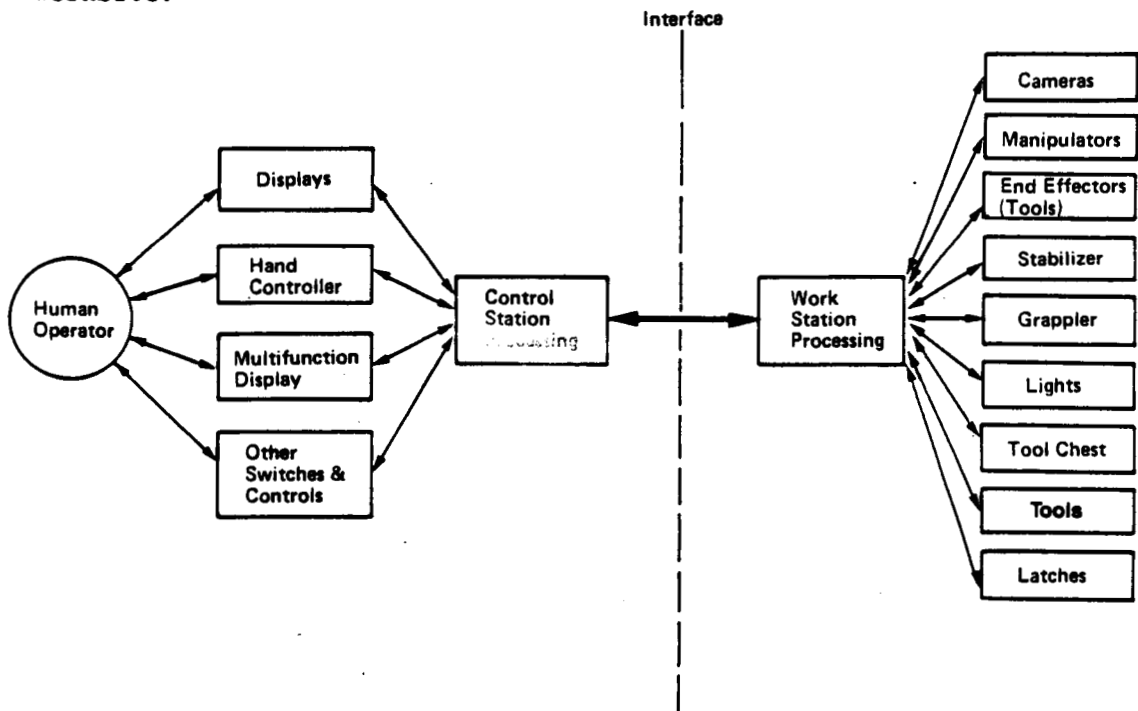

Figure 3-19 TWS System Processing

Table 3-5 describes the tasks to be performed by the control station processing system. These represent functions necessary for interface with the telerobot workstation, monitoring, and safety, as well as hand controller computation.

*Table 3-5 Control Station Processing Tasks*

- 1) Convert and Read Twelve RVDTs/LVDTs
- 2) Run Digital Filter Code
- 3) Compute Handcontroller Kinematics
- 4) Perform Limited Path Generation
- 5) Process Path Information from AI Planners
- 6) Send and Receive Workstation Data
- 7) Monitor Workstation Limits in Force, Velocity, and Joint Position
- 8) Provide Graphic Display of Workstation Data
- 9) Operate Up to 20 Annunciator Lights
- 10) Process Up to 32 Switch Inputs
- 11) Send and Receive Touchscreen Data
- 12) Process Command Codes from Voice Recognition Processor

Figure 3-20 shows the recommended control station architecture. Two Motorola 68020 processors are required, one equipped with a 68881 floating-point coprocessor. One processor is responsible for all user interface and communication. This system can be easily expanded to communicate with an advanced AI planner.

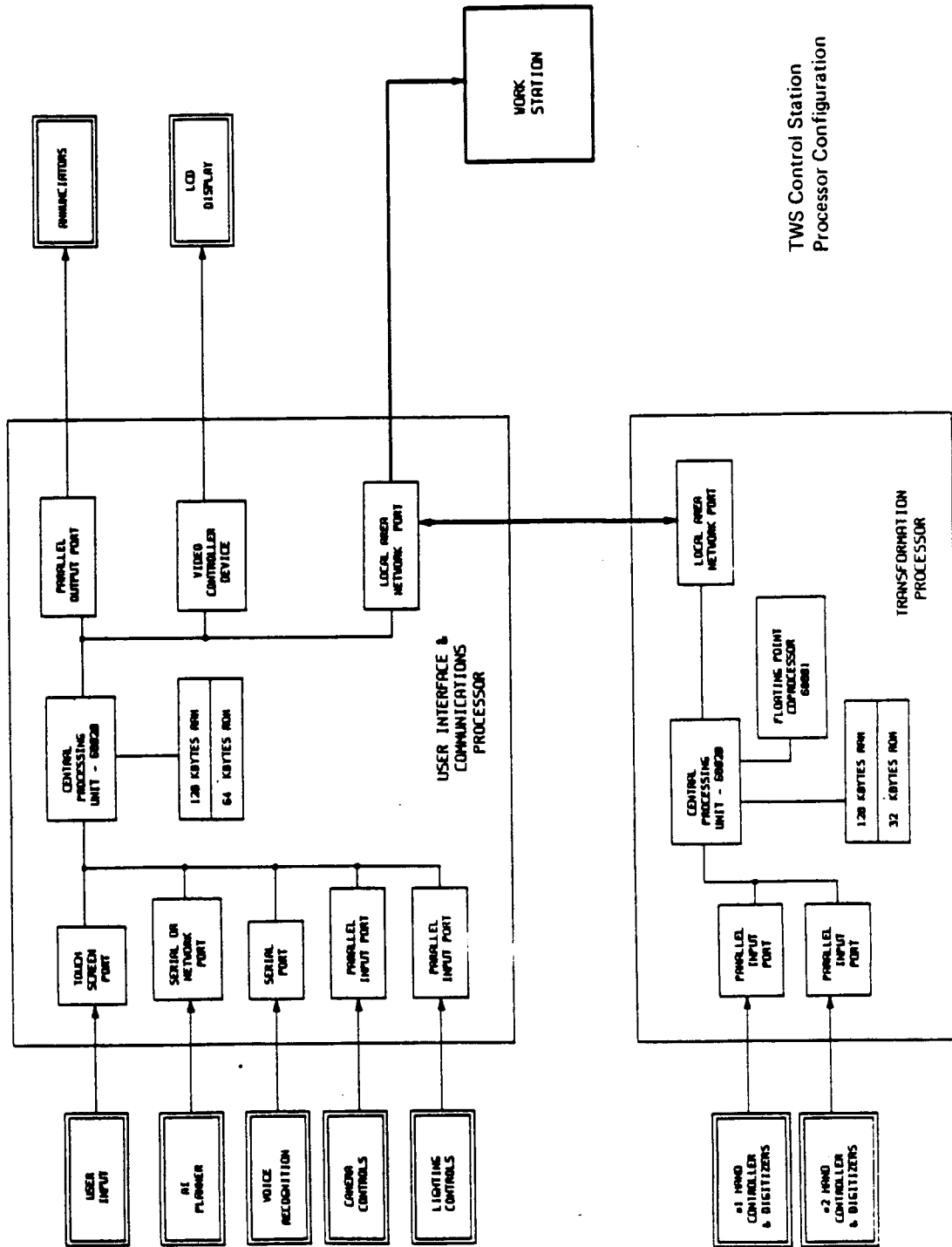

TWS Control Station Processor Configuration

Figure 3-20 TWS Control Station Configuration

The second processor in this system performs all necessary hand control functions. While this primarily involves processing of hand controller sensor data to derive manipulator control commands, sufficient capability is also included to allow processing of manipulator forces and torques for bilateral force reflection.

#### Telerobot Work Station Processing

The telerobot workstation processing system is necessarily more complicated than that for the control station. Table 3-6 shows the primary tasks that must be accomplished by this system. Figure 3-21 shows the recommended architecture. A total of nine Motorola 68020 processors are employed to accomplish all required functions. One processor is dedicated to communication functions with the control station. A single processor is dedicated to performing all interface functions with manipulators, the stabilizer, and sensors. The real-time control system for each manipulator consists of three processors and two floating-point coprocessors. Our experience shows that this provides sufficient capability for handling all advanced servocontrol functions. This final processor in the system is dedicated to supervisory functions between the two manipulator control systems. The need for this additional processing capability when the actions of the two arms are to be coordinated was established in the coordinated dual-arm control work performed under the ITA contract in 1986.

#### 3.3.2 Control Structure

The processing architecture described above supports a wide range of possible manipulator control algorithms. These range from simple position or rate teleoperation strategies through structures capable of supporting autonomous manipulator actions. Figure 3-22 shows the range of control modes recommended for inclusion in the baseline TWS. A key



aspect of the recommended control set is the mode in which teleoperation commands from the operator are used in conjunction with compliant control at the manipulator. This achieves the same basic result as bilateral force feedback to the operator, but without burdening the operator with the task of resolving and correcting sensed forces and torques. This control mode has been implemented in our laboratory system and appears to show a great deal of promise. Initial implementations have been conducted using minimal time delays between the manipulator and operator--greater performance improvement is expected when this mode is used in large time delay situations.

*Table 3-6 Workstation Processing Tasks*

- **Communications Tasks**
  - Buffer Incoming and Outgoing Messages
  - Receive Path Command Data
  - Send Workstation Status Data
  
- **Dual-Arm Supervisory Tasks**
  - Coordinate Dual Arm Motion
  - Operate Manipulator Brakes
  
- **Manipulator Control Tasks**
  - Control Multiprocessor Task Synchronization
  - Perform Manipulator Kinematics/Inverse Kinematics for Each Arm
  - Perform Manipulator Closed-Loop Control for Each Arm
  
- **I/O and Conversion Tasks**
  - Acquire Resolver Data and Tachometer Data
  - Drive Manipulator Motors
  - Acquire Force/Torque Data
  - Operate Camera Controls (Focus, Zoom, Iris, Pan, Tilt)
  - Drive Lighting Controls
  - Follow Arm Movement with Pan/Tilt
  - Operate Manipulator Heaters and Sense Temperature
  - Acquire Proximity Sensor Data
  - Control End Effectors

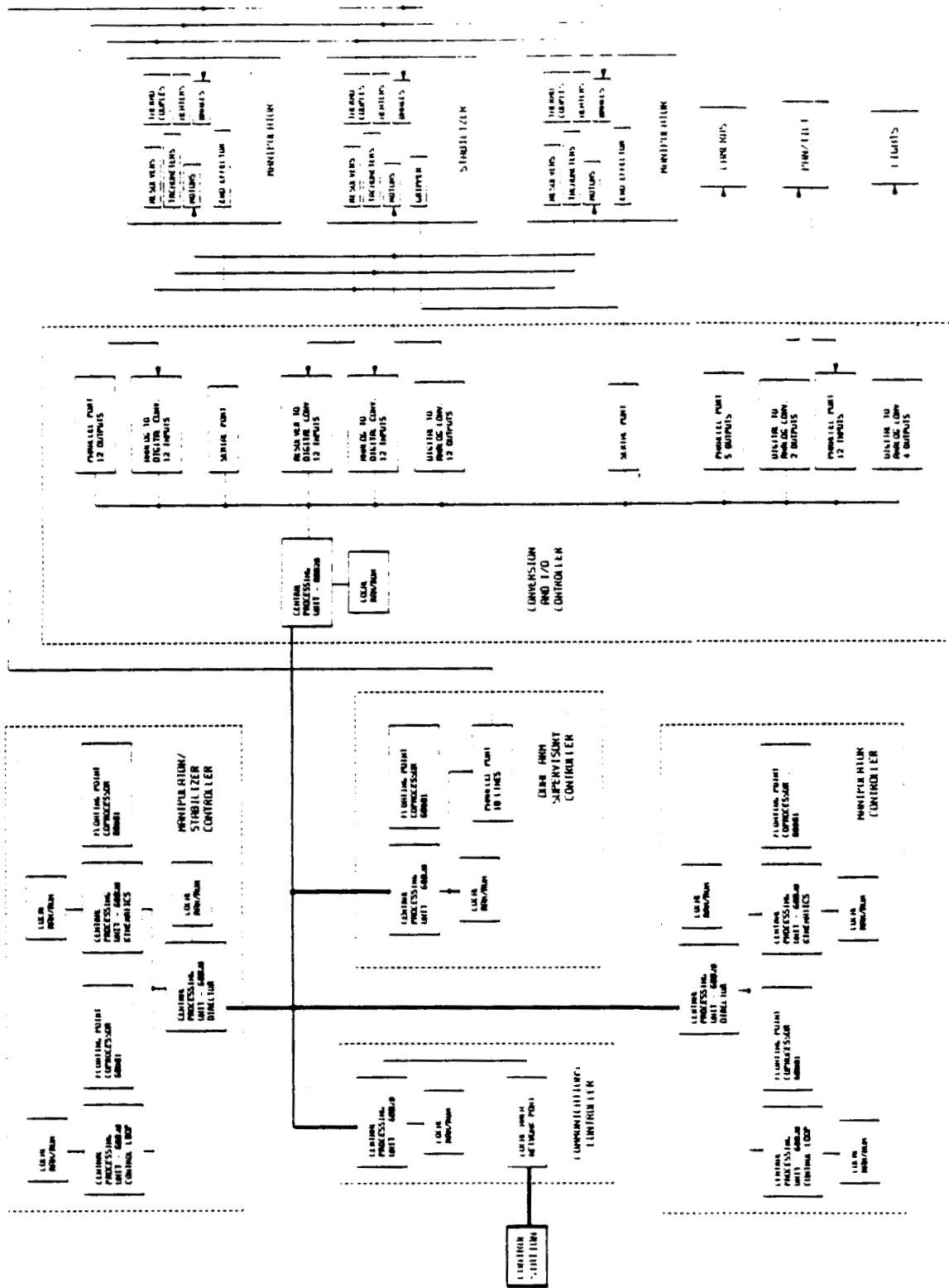

Figure 3-21 Workstation Processing Architecture

- System Operational Modes

- Teleoperation
    - Position
    - Rate
    - Position with Forcefeedback
    - Position with Forcefeedback and Compliant
  - Autonomous
    - Position
    - Compliant
      - Menu Driven
      - Library of Primitive Tasks
- } Single or Dual Arm
- } Single or Dual Arm

*Figure 3-22 TWS Control System Concept*

The basic control structure recommended for implementation on each manipulator is shown in Figure 3-23. This structure has been developed in our laboratory and is the outgrowth of three years of research in compliant control for manipulators. The heart of the structure is a set of joint-space position control loops. Higher level commands are generated from a hand controller, a stored database, or from a higher level planner.

Compliant manipulator action is achieved by measuring and filtering manipulator forces and torques. The particular type of filter that is implemented for each end-effector force or torque determines the impedance the manipulator will exhibit to modify the commanded position and orientation. This results in a manipulator control structure that has the ability to "give" in response to forces and torques resulting from inaccuracy or misalignments in the task or manipulator reference frame.

- Arm Control Structure

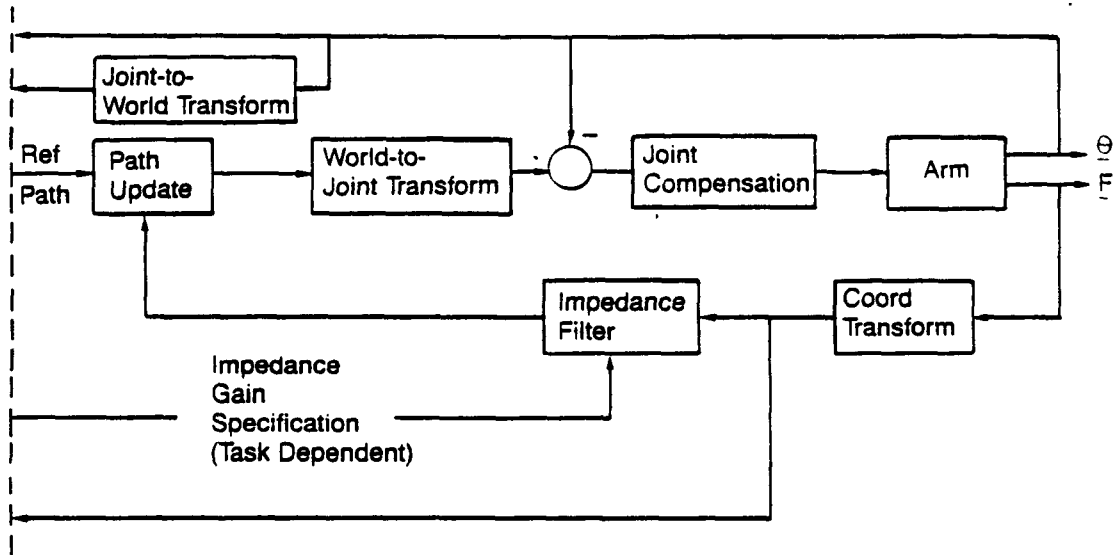

Figure 3-23 TWS Control System Concept Flow Diagram

## 4.0 INTERFACE DEFINITION

---

During the TWS Part I study, the interfaces between the space shuttle and the TWS were developed. The two primary interfaces examined were the electrical interface, consisting of both the communications and power interfaces, and the mechanical interface. In the Part II study, more detail was added to these results to define more general requirements for supporting Space Station. In addition, to examine the problems associated with using TWS as an OMV payload, a preliminary examination of the TWS/OMV interface was performed.

### 4.1 STS/RMS ELECTRICAL INTERFACE

#### 4.1.1 Communications

An important constraint placed on the design of the communications interface is the use of standard payload accommodations as described in the core interface control document (ICD), JSC ICD 2-19001. The wiring available from the shuttle aft flight deck to the payload bay for a standard payload consists of 22 type-HO twisted pairs, 13 type-ML twisted shield pairs, and 20 type-RF twisted shielded pairs. For the TWS interface, the type-HO wires will be used for low-level power and switch applications, providing signals for the safety switches and analog back-up controls. The type-ML wires will be used to provide the digital computer interface between the control station and the telerobot workstation. Finally, the type RF wires will be used to transmit the video signals from the telerobot workstation back to the control station.

There exists a standard set of wiring paths between the crew compartment and the payload bay. The paths include junctions and standard cabling harnesses located along the wiring routes. The TWS

wiring path begins at either Panel L10 or L11 in the aft flight deck where the TWS control station connects to the TWS cable bundle. The TWS cable bundle goes from either of these panels to a payload station distribution panel (PSDP) located beneath these panels. From the PSDP, a standard mixed cabling harness (SMCH) runs the bulkhead at x.603. On the other side of the bulkhead, another SMCH continues to the port side wire tray. From the wire tray, a cable connects to a standard interface panel (SIP), which is a relocatable junction box that can be placed near the payload.

In the case of TWS, the SIP would be placed near the base of the RMS to connect the cabling to the RMS umbilical discussed later. This signal wire routing is shown in Figures 4-1 and 4-2.

The total cable length from the control station to the end of the RMS arm is approximately 170 feet. This includes 100 feet from the control station to the SIP, 20 feet from the SIP to the base of the RMS, and 50 feet from the base to the tip of the RMS.

Instrumentation Wiring Path between Control Station & Work Station

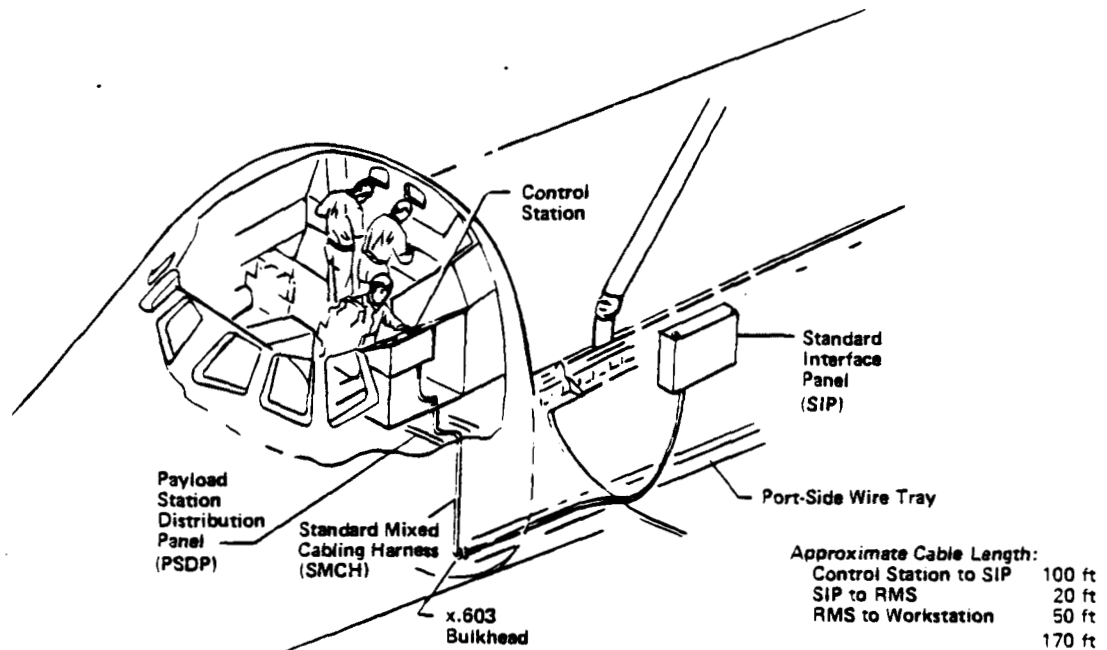
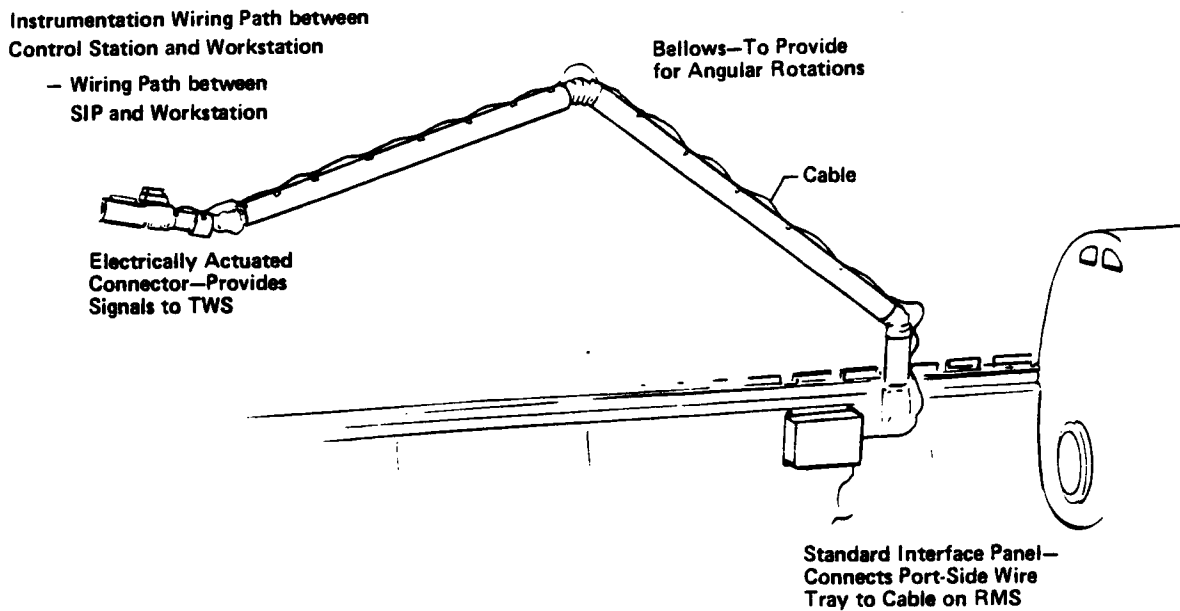

Figure 4-1 Signal Wire Routing



*Figure 4-2 Wire Routing on RMS*

#### 4.1.2 Power

Power wiring for the control station will come either from J10 of standard switch panel (SSP) 1 or from J3 of SSP 2. There are 188 watts available from each SSP. The two panels are wired in parallel so if only one is used, 376 watts could be available. This is substantially greater than the control station requirements, even if FRHCs are used.

Power wiring for the telerobot workstation will come from the electrical power service panel (EPSP) located at bulkhead x.645 in the payload bay. A power SMCH-SIP will connect the EPSP to the base of the RMS, and the TWS wiring harness attached to the RMS will carry power to the workstation. Assuming that TWS will be allotted the full power complement of a standard payload, 1.7 kW will be available from the EPSP. This will be able to meet the TWS average power requirements of approximately 1.2 kW.

#### 4.1.3 RMS Wiring Harness

Because the RMS arm does not provide adequate payload wiring capability for a system such as TWS, an external cable bundle will need to be run along the RMS arm. This cable will contain both the power and the instrumentation wiring. The power consumption of the TWS has been estimated at 1180 W, but the peak consumption could be substantially higher. This requires that No. 4 gauge wire, which has a 0.2-in. diameter, be used to transmit power. The wire bundle for the instrumentation wiring discussed earlier will have a diameter of less than 1 in.

The resulting cable harness will be less than 2 in. in diameter, including insulation and shielding. The hardpoints already provided on the RMS arm for external cabling will be used to attach this harness.

#### 4.1.4 Remote Electrical Connector

To remotely activate TWS, a remotely actuated electrical connector is needed to connect power and instrumentation after the RMS arm successfully mates with the TWS grapple fixture. This connector must be able to accommodate both the instrumentation bundle and the power wiring. It must be able to mate and demate upon an electrical command signal and must provide a status signal for successful/unsuccessful mating.

Presently, no commercial units are available that meet these requirements. However, there are several prototype units available that could meet the TWS requirements with some development work. These units would have to be miniaturized and space qualified, but no insurmountable technical obstacles are foreseen.



#### 4.2 STS PHYSICAL INTERFACE

The primary considerations in developing the mechanical interface between the STS and TWS were the use of standard accommodations where possible and the minimization of the effect on other shuttle payloads. As a result, either Cargo Bay 3 or 4 on the starboard side of the shuttle will be used for the TWS stowage or "berthing" location. TWS in the Cargo Bay 3 location is shown in Figure 4-3. Either location has a high mission availability and is within easy reach of the RMS arm.

- Custom Holding Fixture
  - TWS Held on with Active Latches
  - TWS Slides On/Off When Docked with RMS
- Starboard Cargo Bay 3 or 4
- GAS Beam Capability, 1000 lb max
- High Mission Availability
- Bay 1 and 2 Reserved for MMU and EVA Tool Box
- Within Reach of RMS

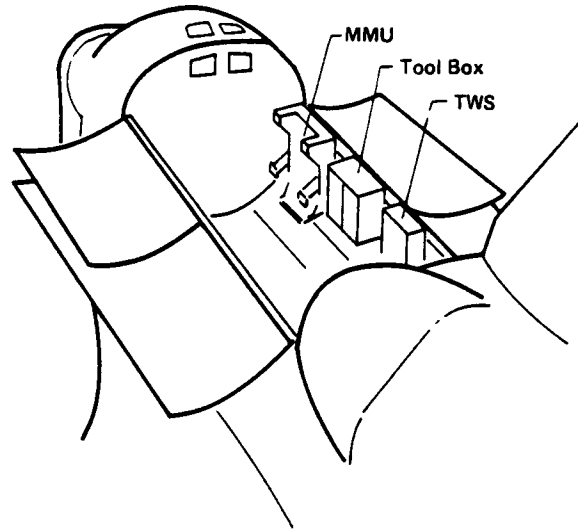
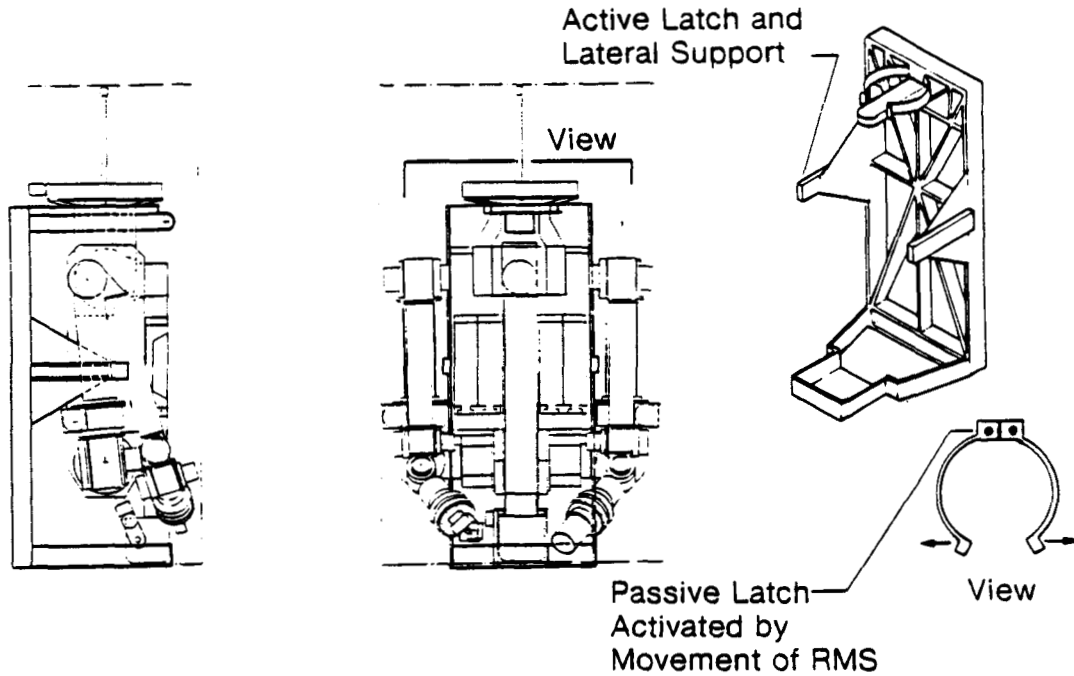

*Figure 4-3 TWS Berthing/Location*

This will require a custom holding fixture, analogous to the FSS in which the MMU is stowed. A concept for this fixture is shown in Figure 4-4. The stowage envelope for TWS in this fixture is actually smaller than the Manned Maneuvering Unit (MMU)/Flight Service Station (FSS) envelope, measuring only 37x23x63 in. The TWS will be secured in the fixture with active latches that can be opened or closed from the TWS control station. Once the RMS has successfully mated with the standard grapple fixture mounted in TWS, these latches would be released to allow the RMS to move the TWS to the worksite. When being returned to its holding fixture, the TWS would first be positioned in the fixture and the latches closed before being released from the RMS effector.

#### 4.3 OMV INTERFACE

TWS has been suggested as an OMV payload to perform in-situ servicing of spacecraft rather than returning them to Space Station or Earth to be serviced. A preliminary examination of the TWS/OMV interface indicates the most difficult problems to be evaluated are in the areas of power supply and communications.



*Figure 4-4 TWS Shuttle Bay Restraint System*

Current designs of the OMV clearly show it will be incapable of providing sufficient power to TWS. As a result, a battery kit will be needed to supply TWS with adequate power. Because the design of OMV has not been finalized, the amount of power that OMV can supply to TWS has not been determined. Table 4-1 shows the battery kit options depending on the amount of power available from OMV.

Perhaps a more difficult problem in interfacing with OMV is the data communication rate that will be possible. Because of the transmission overhead and encryption requirements, current estimates of the command rate available to control TWS range to less than one kilo-bit per seconds (kbps). It would be futile to base an interface design on such tight constraints until communication rates are firmly established.

Finally, the mechanical interface between the TWS and OMV are simple in comparison to these other interfaces. Any one of several standard structural interfaces to OMV would be adequate for the TWS. The best concepts will become more apparent as both OMV design and satellite serving scenarios mature.

**Table 4-1 OMV-Configured TWS Power Equipment List**

Equipment	Unit Wt, lb	Unit Vol, ft <sup>3</sup>	Qty Reqd	Total Wt, lb
Power Distribution Unit	TBD	TBD	1	TBD
Cabling	20	—	—	100
Safing Battery Assy <sup>1</sup>	5.7	0.060	1	5.7
Battery Kit Options: <sup>1,3</sup>				
• No Kit Reqd (100% Host Vehicle Pwr)	0	0	0	0
• W/OMV Host (300-W Supplement) <sup>4</sup>	55	0.58	(As Reqd)	55
• Total SFE Pwr (1.3 kW) from Batt Kit	210	2.3	(As Reqd)	210
• Serviced Payload Power <sup>5,6</sup>	370	3.9	(As Reqd)	370
• Power for Tools <sup>6</sup>	TBD	TBD	TBD	TBD

<sup>1</sup>Rechargeable Silver-Zinc

<sup>2</sup>Based on 500 W for 30 minutes

<sup>3</sup>Kit Attached to SFE or Located in Host Vehicle or Portions in Each (TBD); Figures Based on 8-hr Missions

<sup>4</sup>Assuming 1 kW Provided by OMV

<sup>5</sup>Wts and Vols Assume 2-kW Serviced Payload Worst-Case Requirement; for Other Than 2-kW Worst-Case, Scale Wts and Vols Proportionally

<sup>6</sup>Add Wts and Vols to Figures of Other Battery Kit Options As Appropriate for Total Battery Kit Wt and Vol

## 5.0 PROGRAM PLAN

---

As the final task in the TWS study, we examined the effort required to develop both a test bed and an operational TWS system, as well as system cost. A test bed system was deemed necessary to serve as a means of fully evaluating mechanisms, processing architecture concepts, control laws, sensors, and system performance. A concept for a test bed system is shown in Figure 5-1. One of the key features of the test bed concept is the incorporation of all test bed components into a single pallet. To demonstrate all key aspects of TWS performance, only the two primary manipulator arms are required. Additionally, the electrical interface with the RMS can be considerably simplified because, for test bed purposes, mating of the connector could be handled by EVA. Figure 5-2 shows the TWS test bed in a deployed mode. Operation in conjunction with the RMS can be adequately verified where the second manipulator arm acts as a stabilizer for the system. By mounting the system on the pallet, dual-arm operations can also be verified.

The top-level program plan is shown in Figure 5-3. The development of the test bed and operational systems are conducted in parallel with the idea that test bed flight data will support final development of the operational system. The operational system development should follow a Phase B, Phase C/D development cycle. Based on our estimates, an operational system could be available in the 1994 timeframe.

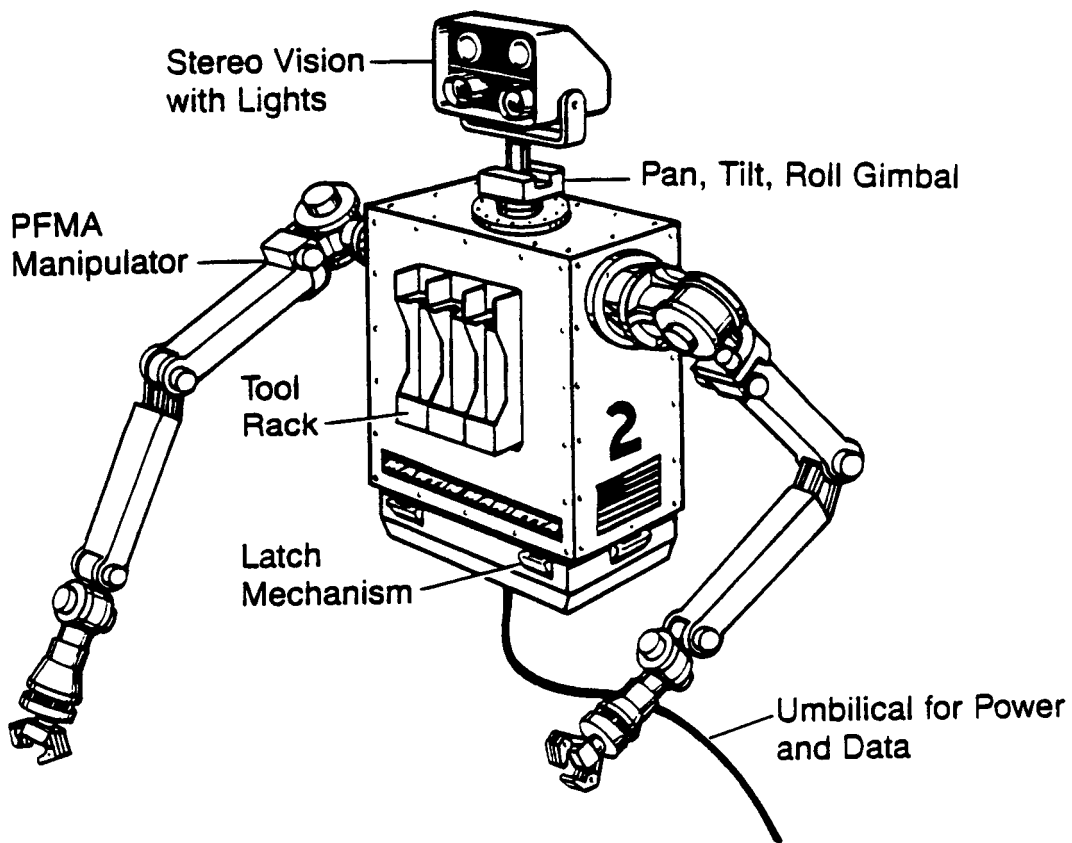

*Figure 5-1 Robotic Servicer*

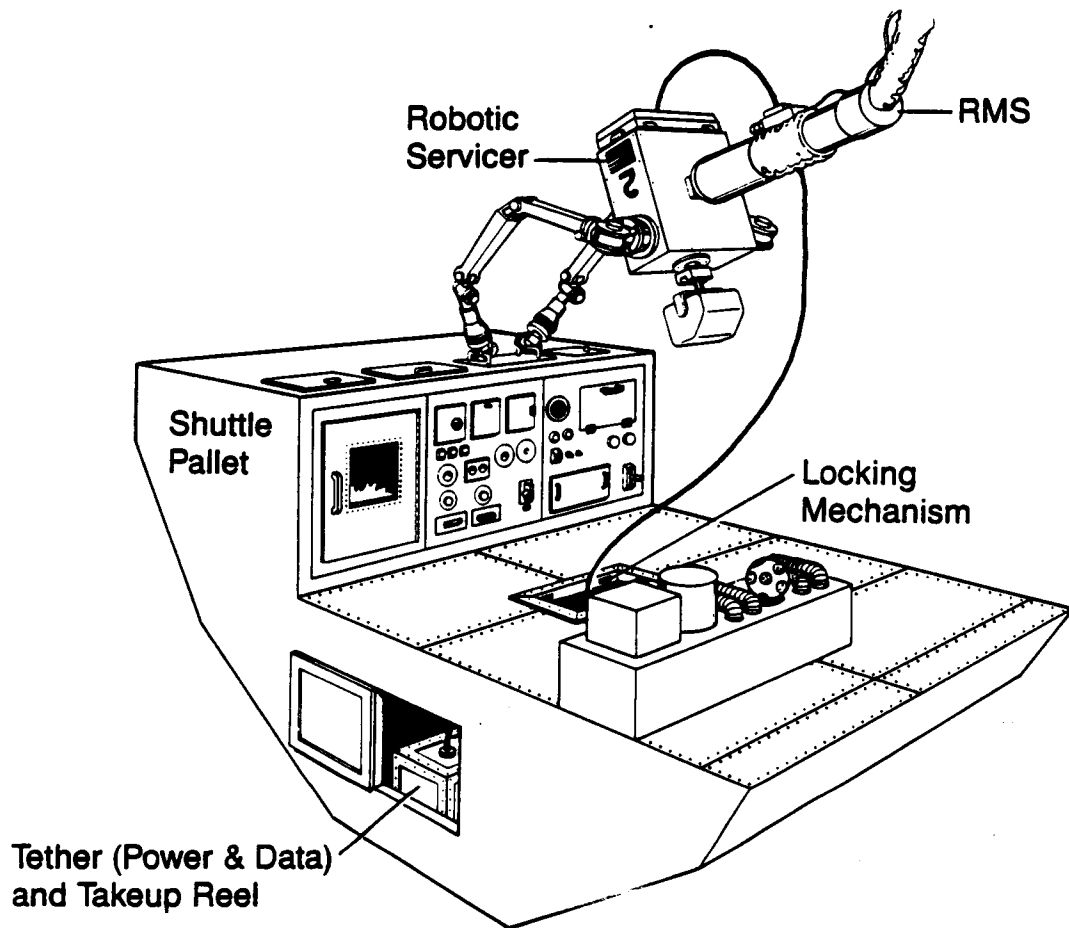

*Figure 5-2 Robotic Servicer in a Deployed Mode*

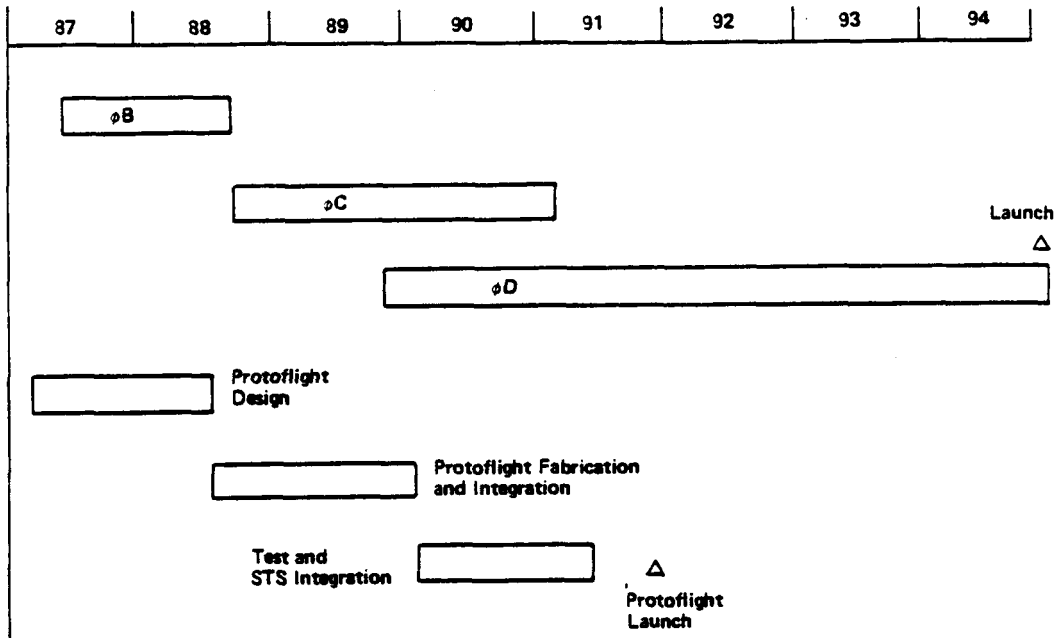

Figure 5-3 Program Plan

Tables 5-1 and 5-2 summarize cost estimates developed for both the telerobot workstation and control station elements of the TWS. These rough order of magnitude (ROM) estimates are in 1987 dollars and are based on experience in producing items of similar complexity. This estimate includes a system for STS deployment only; insufficient data was available to allow assessment of costs associated with an OMV system. Also, this estimate does not include the test bed system. To be available in the near term, the test bed system would have to use a large amount of currently available technology. The decision as to what available technology could be used for rapid deployment of a test bed was beyond the scope of this study.

In addition to the costs shown, an additional \$1.0 million dollars would be required for design and development of shuttle integration technology. Recurring costs for shuttle integration would be \$300k per flight system. This results in design and development costs of \$25.77M and a production cost of \$12.9M per flight unit.

*Table 5-1 Telerobot Workstation Cost Estimate*

<u>Item</u>	<u>Design and Development</u>	<u>Production</u>
Manipulators	1.00M	2.00M
Stabilizer	.50	.75
End Effectors	.80	.40
Tools	-	.50
Tool Racks	.50	.50
Processors/Electronics	4.00	2.00
Stereo Camera Package	.75	.50
Head Position System	.20	.40
RMS Grapple Fixture	.07	.05
Auxiliary Cameras	.80	.60
Chest Structure Assembly	2.00	1.00
Software	<u>8.00</u>	<u>1.00</u>
Workstation Subtotal	18.62M	9.70M

*Table 5-2 Control Station Cost Estimate*

<u>Item</u>	<u>Design and Development</u>	<u>Production</u>
Multifunctional Display	.15M	.10M
Auxiliary Monitor	-	.10
Stereo Display	1.00	.70
Camera Position Sys Elec	1.00	.50
Polarized Glasses	-	-
6-DOF Hand Controllers	1.00	.50
Control Station Processor	1.00	.50
Software	<u>2.00</u>	<u>.50</u>
Control Station Subtotal	6.15M	2.90M



## 6.0 CONCLUSIONS AND RECOMMENDATIONS

---

This study effort has shown that the development of a space robotic servicing system is totally feasible. More importantly, many of the key elements of such a system are currently available as the result of previous and ongoing technical efforts. In many cases, decisions remain to be made concerning tradeoffs between options available to satisfy system technology requirements.

The primary recommendation resulting from this study is for the development of a flight test bed system that could be used to establish a performance database to assist some of the necessary technical decisions described in our study package. A properly designed flight test bed system would prove tremendously useful in terms of rapidly evaluating new technology in a realistic setting and would be a great benefit in the development of the operational system.