

NASA Technical Memorandum 4011

**Tutorial and Hands-On
Demonstration of a Fluent
Interpreter for CARE III**

Anna L. Martensen
PRC Kentron, Inc.
Hampton, Virginia

Salvatore J. Bavuso
Langley Research Center
Hampton, Virginia



National Aeronautics
and Space Administration

Scientific and Technical
Information Division

1987

Preface

On February 22 to 24, 1984, a workshop was conducted at the NASA Langley Research Center on the CARE III (Computer-Aided Reliability Estimation) capability. A major feature of the workshop was the hands-on use of CARE III Version V by workshop attendees in the Langley Avionics Integration Research Lab (AIRLAB). Eight examples were designed to highlight the important CARE III features and to demonstrate the use of the CARE III user-friendly interface program CARE3MENU. These example problems were then published in NASA TM-85811, *CARE III Hands-On Demonstration and Tutorial*.

Since February 1984, both CARE III and the CARE3MENU program have been modified and improved. CARE III Version VI enhancements are described by Bryant and Stiffler in NASA CR-177963, and the CARE3MENU modifications are described by Martensen in NASA CR-178251. This document reflects the use of CARE III Version VI and the modified CARE3MENU and is an update of NASA TM-85811. In summary, the following changes to CARE III and the CARE3MENU program are demonstrated in this document:

CARE III

1. "Internal redundancy," as described in NASA CR-177963, is illustrated in example problem 2.
2. The new output format is shown in appendix A.

Most CARE III changes were designed to decrease program execution time or to increase efficiency and are not directly demonstrated in this document.

CARE3MENU

1. Previously created files may be edited, as shown in example problems 1, 2, and 4.
2. A "review" capability is now available. Users may review all or part of the input file when entering data in order to correct past mistakes, verify previous inputs, or change the model.
3. Partial files may be created during a session and finished in later sessions.

PRECEDING PAGE BLANK NOT FILMED

Contents

Preface iii

Figures vii

1. Introduction and Outline 1

2. Example Problem 1A Description 2

2.1. System Failure Criteria 3

2.2. Input Data for the Fault Occurrence Model 3

2.3. System Tree 3

2.4. Using the User-Friendly Interface 3

2.5. Example Problem 1B Description 8

2.6. Comments 8

3. Example Problem 2A Description 8

3.1. System Failure Criteria 9

3.2. Input Data for the Fault Occurrence Model 9

3.3. System Tree 9

3.4. Using the User-Friendly Interface 10

3.5. Example Problem 2B Description 12

4. Example Problem 3 Description 13

4.1. System Failure Criteria 14

4.2. Input Data for the Fault Occurrence Model 15

4.3. System Tree 15

4.4. Using the User-Friendly Interface 16

4.5. Comments 18

5. Example Problem 4A Description 19

5.1. System Failure Criteria 19

5.2. Input Data 20

5.3. System Tree 20

5.4. Single-Fault Model 20

5.5. Using the User-Friendly Interface 21

5.6. Example Problem 4B Description 23

5.7. Comments 24

6. Example Problem 5 Description 24

6.1. System Failure Criteria 25

6.2. Input Data 25

6.3. System Tree 26

6.4. Single-Fault Model 26

6.5. Using the User-Friendly Interface 27

7. Example Problem 6 Description 29

7.1. System Failure Criteria 30

7.2. Input Data 30

7.3. System Tree 31

7.4. Single-Fault Model 31

7.5. Critical Pair Tree	31
7.6. Using the User-Friendly Interface	32
8. Example Problem 7 Description	34
8.1. System Failure Criteria	35
8.2. Input Data	35
8.3. System Tree	36
8.4. Single-Fault Model	36
8.5. Critical Pair Tree	37
8.6. Using the User-Friendly Interface	37
9. Example Problem 8 Description	39
9.1. System Failure Criteria	40
9.2. Input Data	40
9.3. System Tree	41
9.4. Single-Fault Model	42
9.5. Critical Pair Tree	42
9.6. Double Intermittent Fault Model	43
9.7. Using the User-Friendly Interface	44
10. Concluding Remarks	47
Appendix A—Output Listings	48
Appendix B—CARE III Variables	87
Appendix C—Executing CARE III Using a VAX/VMS System	92
11. References	93

Figures

	Page
2.1. Example problem 1A functional block diagram	2
2.2. Example problem 1A system tree	3
3.1. Example problem 2A functional block diagram	9
3.2. Example problem 2A system tree	9
4.1. Example problem 3 functional block diagram	14
4.2. Example problem 3 system tree	15
5.1. Example problem 4A functional block diagram	19
5.2. Example problem 4A system tree	20
5.3. Example problem 4A permanent single-fault model	21
6.1. Example problem 5 functional block diagram	24
6.2. Example problem 5 system tree	26
6.3. Example problem 5 general single-fault model	27
7.1. Example problem 6 functional block diagram	30
7.2. Example problem 6 system tree	31
7.3. Example problem 6 permanent single-fault model	31
7.4. Example problem 6 critical pair tree	32
8.1. Example problem 7 functional block diagram	35
8.2. Example problem 7 system tree	36
8.3. Example problem 7 permanent single-fault model	36
8.4. Example problem 7 critical pair tree	37
9.1. Example problem 8 functional block diagram	40
9.2. Example problem 8 system tree	41
9.3. Example problem 8 general single-fault model	42
9.4. Example problem 8 critical pair tree	43
9.5. Example problem 8 double intermittent fault model	44

1. Introduction and Outline

This tutorial is designed to illustrate the primary features of the CARE III and CARE3MENU capabilities. Users of this tutorial should have a basic understanding of the CARE III program and the input data used to describe the system(s) of interest. (See refs. 1 and 2.) Mathematical details can be found in references 3 and 4. In particular, the following concepts should be well understood before using the CARE3MENU program:

1. The "behavioral decomposition" technique used with CARE III to separate the descriptions of fault arrivals and fault handling.
2. The use of stages to describe system components, where stages are composed of one or more identical modules. With CARE III Version VI, modules may further be broken into submodules.
3. The CARE III fault handling model (FHM) used to describe the system's response to a fault arrival. Faults may be permanent, intermittent, or transient.
4. The use of fault trees to describe system failure.
5. The critical pair tree, which defines the faulty module pairs that are assumed to cause system failure because of improper fault handling.

To avoid possible confusion between terms used in this and other documents, the following terms are defined and are used consistent with these definitions throughout the document:

Fault—A condition which temporarily or permanently affects the ability of a module to perform its function.

Error—A condition in which a module is incorrectly performing its function.

Failure—Loss of system function.

The first example problems are described in detail to familiarize the user with CARE3MENU and CARE III terminology. Subsequent problems contain less detail on the mechanisms of operating the CARE3MENU program and more on the reliability and design aspects. CARE3MENU details may be found in reference 5. The user is encouraged to exercise the example problems in the suggested order. Output listings are presented in appendix A, and a description of each CARE III input variable is included in appendix B.

Three conversations are distinguished in the example problems. **Boldface words or characters** represent messages generated by the computer. Underlined words or characters are user inputs to be keyed-in. Other text that is neither boldface nor underscored is information from the instructor to guide the user.

Each problem is divided into at least four parts: the problem description (which includes the functional block diagram of the system), the system failure criteria, the input data, and the system tree. As examples become more complex, additional information is given. Following this introductory information are instructions for using the user-friendly interface to input each of the example problems.

The following is an outline to illustrate the flow of the tutorial:

Building on the System Fault Tree (Minimum Fault Handling Model)

Problem 1—Nonredundant system tree (exponential and Weibull fault occurrences)

- No functional redundancy
- No redundancy within the stages
- No coverage (default coverage)
- No internal redundancy

Problem 2—Nonredundant system tree

- No functional redundancy
- Redundancy within the stages
- Internal redundancy within modules
- No coverage

- Problem 3—Redundant system tree
 - Functional redundancy
 - No redundancy within the stages
 - No coverage
 - No internal redundancy

Building on the Fault Handling Model (Minimum System Tree Complexity)

- Problem 4—Nonredundant system tree
 - Coverage: single-point failure
 - Fault type: permanent (exponential and uniform)
- Problem 5—Redundant system tree
 - Coverage: single-point failure
 - Fault types (exponential only):
 - Permanent
 - Transient
 - Intermittent
- Problem 6—Redundant system tree
 - Coverage: single-point and critical pair failures
 - Fault type (exponential only): permanent
 - Critical pair failures within stages
 - Spare units (NOP)
- Problem 7—Redundant system tree
 - Coverage: critical pair failures
 - Fault type (exponential only): permanent
 - Critical pair failures within and across stages
 - Spare units (NOP)
- Problem 8—Redundant system tree
 - Coverage: critical pair failures
 - Fault types (exponential only):
 - Permanent
 - Transient
 - Intermittent
 - Critical pair failures within a stage
 - Double intermittent model introduced
 - Spare units (NOP)

2. Example Problem 1A Description

This example illustrates the simplest of system fault occurrence models. There are three stages in the nonredundant system (fig. 2.1): sensor, computer, and actuator. The probability of system failure for mission times from 0 to 10 hours is to be predicted for exponential (component) failure rates λ and then computed for Weibull (component) failure rates. This example ignores the fault handling capabilities of the system and therefore reduces the problem to a classic fault tree assessment.



Figure 2.1. Example problem 1A functional block diagram.

2.1. System Failure Criteria

The system failure criteria for example problem 1A are as follows:

1. The system fails if any stage fails.
2. A stage fails if a failure occurs in the stage.

2.2. Input Data for the Fault Occurrence Model

Sensor module:	$\lambda = 1.5 \times 10^{-5}$	$\Omega = 1.0$ (default)*	$\Omega = 1.1^\dagger$
Computer module:	$\lambda = 4.8 \times 10^{-4}$	$\Omega = 1.0$ (default)*	$\Omega = 1.0$ (default) [†]
Actuator module:	$\lambda = 3.7 \times 10^{-5}$	$\Omega = 1.0$ (default)*	$\Omega = 1.1^\dagger$

*Problem 1A (exponential).

[†]Problem 1B (Weibull).

2.3. System Tree

The system fault tree (fig. 2.2) describes the relationship between system failure and the loss of stages because of hardware depletion.

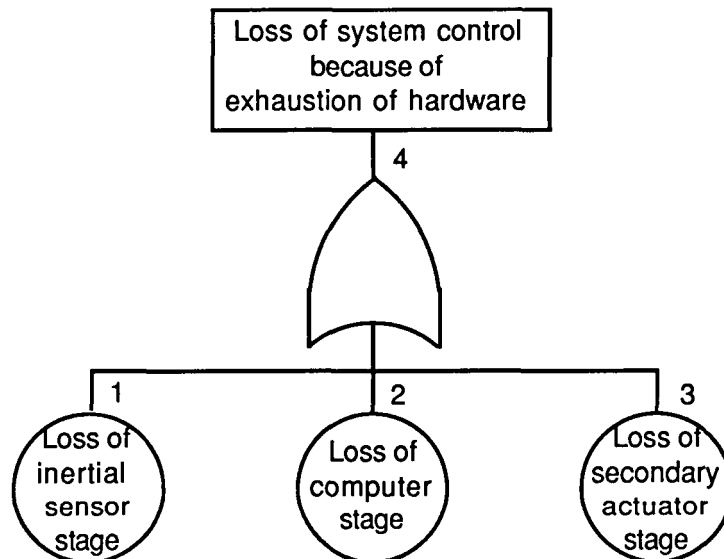

Figure 2.2. Example problem 1A system tree. (System fails if at least one stage fails.)

2.4. Using the User-Friendly Interface

Use of the user-friendly interface for example problem 1A is outlined in the following section.

Preliminaries:

1. For assistance or help, type “?” in lieu of a requested input at any time except when working the fault trees.
2. Out-of-range values will not be accepted. (See User’s Guide, ref. 2.)
3. The user can type in either uppercase or lowercase characters.
4. In many cases, values are already supplied for the parameters. These are default values, and the user can elect to use these or may enter new values. The defaults are selected by pressing the return key. This paper indicates that default values are to be used with “cr (default),” where cr stands for carriage return.

Enter the CARE3MENU program by typing @CARE3MENU. The following screens will appear:

CARE3MENU—Menu Based Data Input for CARE III

I—Input CARE III model
A—Alter an existing model
S—Store the current model
E—Exit CARE3MENU

Enter Desired Function: I cr
(Begin by selecting input.)

Stage Description Input

Stage Name: SENSOR cr

Number of Beginning Modules in Stage: 1 cr (default)

Minimum Number of Modules for Stage Operation: 1 cr (default)

Number of Beginning Submodules per Module: 0 cr (default)

Minimum Number of Submodules for Module Operation: 0 cr (default)

Spare Submodules On-Line (T/F): T cr (default)

Set(s) of Modules Subject to Critical Pair Failures: cr (default)

Critical Fault Threshold: 0 cr (default)

Number of Fault Handling Models Assigned to this Stage (opt.): 0 cr

Verify Input (Y or N): Y cr

(Type Y to accept input and N to make corrections. Note that the number of fault handling models (FHM's) assigned to this stage is prespecified.)

Stage Description Input

Stage Name: COMPUTER cr

Number of Beginning Modules in Stage: 1 cr (default)

Minimum Number of Modules for Stage Operation: 1 cr (default)

Number of Beginning Submodules per Module: 0 cr (default)

Minimum Number of Submodules for Module Operation: 0 cr (default)

Spare Submodules On-Line (T/F): T cr (default)

Set(s) of Modules Subject to Critical Pair Failures: cr (default)

Critical Fault Threshold: 0 cr (default)

Number of Fault Handling Models Assigned to this Stage (opt.): 0 cr

Verify Input (Y or N): Y cr

Stage Description Input

Stage Name: ACTUATOR cr

Number of Beginning Modules in Stage: 1 cr (default)

Minimum Number of Modules for Stage Operation: 1 cr (default)

Number of Beginning Submodules per Module: 0 cr (default)

Minimum Number of Submodules for Module Operation: 0 cr (default)

Spare Submodules On-Line (T/F): T cr (default)

Set(s) of Modules Subject to Critical Pair Failures: cr (default)

Critical Fault Threshold: 0 cr (default)

Number of Fault Handling Models Assigned to this Stage (opt.): 0 cr

Verify Input (Y or N): Y cr

Stage Description Input

Stage Name: END cr

(All the stages have been input. Once END is typed and the return key pressed, the screen will disappear and the next screen will be displayed.)

C—Continue to next screen
T—Total Review of the model
P—Partial Review of the model
S—Store current model
E—Exit CARE3MENU

Enter Desired Function: C cr
(Continue to the Fault Handling Model Input.)

For models where the user specifies 0 fault handling models assigned to each stage, the CARE3MENU program bypasses the entry of one or more FHM's. It is assumed that the user is conducting a fault tree analysis with no consideration given to fault handling or critical near-coincident faults.

A "dummy" FHM entitled "(NONE)" is created and included in the input file to satisfy the CARE III requirement that at least one fault handling model be assigned to each stage. This fault handling information is not used by the CARE III program.

Fault Occurrence Models

Stage: **SENSOR**

FHM Number: **1**

Fault Type: **(NONE)** cr (default)

FOM (Weibull/Exponential): **EXPONENTIAL** cr (default)

Lambda = **1.5 E-5** cr (This is the rate at which the sensor fails.)

Omega = **1.000000** cr (default)

Fault Type Selection(s)
(NONE)

Verify Input (Y or N): Y cr

(Type Y to accept input, N to make corrections.)

Specified No. of FHM's Reached

(The number of FHM's was prespecified for this stage.)

Note that fault arrivals are distributed exponentially and therefore Omega = 1. Omega ≠ 1 indicates a nonconstant (nonexponential) hazard rate.

Fault Occurrence Models

Stage: **COMPUTER**

FHM Number: **1**

Fault Type: **NONE** cr (default)

FOM (Weibull/Exponential): **EXPONENTIAL** cr (default)

Lambda = **4.8 E-4** cr

Omega = **1.000000** cr (default)

Fault Type Selection(s)
(NONE)

Verify Input (Y or N): Y cr

Fault Occurrence Models

Stage: ACTUATOR

FHM Number: 1

Fault Type: NONE cr

FOM (Weibull/Exponential): EXPONENTIAL cr (default)

Lambda = 3.7 E-5 cr

Omega = 1.000000 cr (default)

Fault Handling Model Names

(NONE)

Verify Input (Y or N): Y cr

*** Specified No. of FHM's Reached ***

Information Summary for Use in Checking System and Critical Pair Trees

Stage Name	Stage Number	No. of Modules In Stage	No. of Submodules per Module
SENSOR	1	1	1
COMPUTER	2	1	1
ACTUATOR	3	1	1

C—Continue to next screen

T—Total Review of the model

P—Partial Review of the model

S—Store current model

E—Exit CARE3MENU

Enter Desired Function: C cr

(Continue with the tree entry.)

(This information is used for labeling the system tree. The stage numbers are used to label the tree inputs. At this point the user would transfer these numbers to the system tree or verify that the tree is numbered correctly. Note that for this example the system tree has already been labeled.)

Ready to Begin Failure Configuration Input

(This screen warns the user that scrolling screens will be used, as opposed to menus. This means that corrections must be made before the cr. If a mistake is made and cr has been pressed, editing a previously typed line will not be possible until the **Continue/Review/Store/Exit** menu is reached. Answering N will allow the user to correct mistakes. Note that a ? at this point will bring up the HELP screens, but once inside the scrolling screens, the user will not be allowed to access the help function.)

Type any key to continue... cr

Enter "?" for Menu Help

System Fault Tree Input

Enter System Fault Tree Label

SYSTEM TREE EX 1 cr

System Fault Tree Input

Enter Input Event ID Range, Output Gate ID Range

INPUT EVENT ID RANGE: 1 3

OUTPUT GATE ID RANGE: 4 4 cr (Spaces should separate the numbers.)

(Briefly, the first two numbers should be the range of inputs, where the inputs will be the stages entered by the user. The output gate ID range will indicate the range of outputs described by the tree. In this case, the ranges are 1 to 3 for the inputs and 4 to 4 for the outputs. The User's Guide (ref. 2) provides more detail. Once cr is typed, the next screen will appear.)

System Fault Tree Input

Enter System Fault Tree Logic Block

4 O 1 2 3 cr

(The 4 is the OR gate output, the letter O is the symbol for the gate, and 1, 2, and 3 are inputs. Because the range of outputs was indicated above, CARE3MENU will automatically prompt with the output gate numbers.)

The critical pair tree information is usually input at this point. However, because the user specified 0 FHM's assigned to each stage, it is assumed that a standard fault tree analysis is to be performed and that no critical near-coincident fault information is required.

Output Control Options Input

Output Option (1-4): 1 cr (default)

Coverage Functions Plot (T or F): F cr (default)

Coverage Y-Axis Selection (Y-Linear, Y-Log, Both, Log-log): Y-LOG cr (def)

Reliability Functions Plot (T or F): F cr (default)

Reliability Y-Axis Selection (Y-Linear, Y-Log, Both, Log-log): Y-LOG cr (def)

Enter "?" for Menu Help

(Normal screen editing is now restored.)

Verify Input (Y or N): Y cr

C—Continue to next screen

T—Total Review of the model

P—Partial Review of the model

S—Store current model

E—Exit CARE3MENU

Enter Desired Function: C cr

(Continue to the Runtime Control Options Input.)

Runtime Control Options Input

Mission Time: 10 cr

Integration Steps: LOGARITHMIC cr (default)

Timebase (Hours, Minutes, Seconds, Days, Years): HOURS cr (default)

Cut Truncation Value = 0.100000E-09 cr (default)

QPTRNC Value = 0.100000E-01 cr (default)

NPSBRN Value = 20 cr (default)

CKDATA (T/F): T cr (default)

Enter "?" for Menu Help
Verify Input (Y or N): Y cr

MODEL INPUT COMPLETE

Do you wish to review or alter this model (Y/N)? N cr

File Name Input

Enter File Name for Model Storage: EX1A.DAT cr

(The file is stored, and all variables are cleared. If, on the next menu, the user attempts to use S—Store the current model, an error message is displayed indicating that no file exists.)

Verify Input (Y or N): Y cr

CARE3MENU—Menu Based Data Input for CARE III

I—Input CARE III model
A—Alter an existing model
S—Store the current model
E—Exit CARE3MENU
Enter Desired Function: E cr
(Exit the program.)

FORTTRAN STOP (CARE3MENU has been exited.)

Directions for executing the CARE III input file EX1A.DAT can be found in appendix C.

2.5. Example Problem 1B Description

To observe the effects of Weibull failure distributions on system reliability, reexecute the CARE3MENU program and **ALTER** the file just generated. When the **Fault Occurrence Models** screens are reached, choose the Weibull distribution in lieu of the exponential and give the Ω values listed below (as shown in section 2.2). The values were chosen to reflect increasing hazard rates for the mechanical sensor (e.g., rate gyros) and actuator components.

Sensor module:	$\lambda = 1.5 \times 10^{-5}$	$\Omega = 1.1$
Computer module:	$\lambda = 4.8 \times 10^{-4}$	$\Omega = 1.0$ (default)
Actuator module:	$\lambda = 3.7 \times 10^{-5}$	$\Omega = 1.1$

2.6. Comments

The following comments can be made concerning example problems 1A and 1B:

1. The proper selection of defaults can significantly reduce the input time.
2. Weibull-exponential distributions can be used in any combination in any CARE III run.

3. Example Problem 2A Description

Problem 2A is another simple system (fig. 3.1). However, this system includes redundancy within the stages (i.e., four computers instead of one). Mission time is still 10 hours and hazard rates are constant (exponential times to failure). As in example problem 1, fault handling is assumed to be perfect.

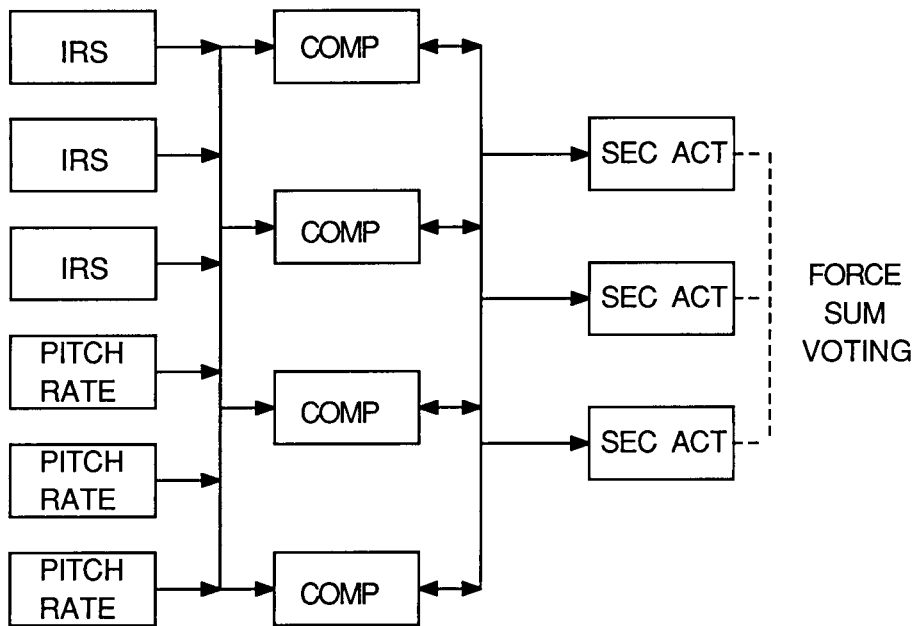

Figure 3.1. Example problem 2A functional block diagram.

3.1. System Failure Criteria

The system failure criteria for example problem 2A are as follows:

1. The system fails if any stage fails.
2. The inertial reference sensor stage fails if two of three modules fail.
3. The pitch rate stage fails if two of three modules fail.
4. The computer stage fails if three of four modules fail.
5. The secondary actuator stage fails if two of three modules fail.

3.2. Input Data for the Fault Occurrence Model

Inertial reference sensor modules:	$\lambda = 1.5 \times 10^{-5}$
Pitch rate sensor modules:	$\lambda = 1.9 \times 10^{-5}$
Computer modules:	$\lambda = 4.8 \times 10^{-4}$
Secondary actuator modules:	$\lambda = 3.7 \times 10^{-5}$

3.3. System Tree

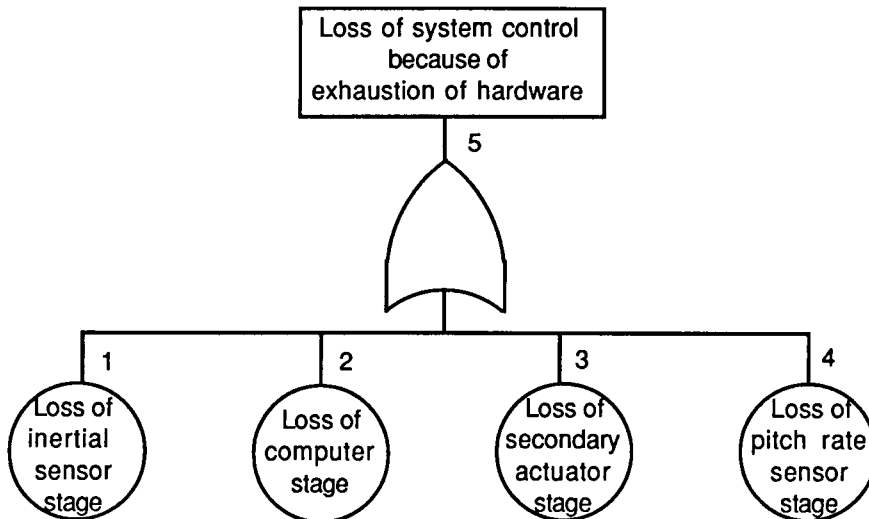

Figure 3.2. Example problem 2A system tree.

3.4. Using the User-Friendly Interface

Preliminary:

This problem uses slightly less CARE3MENU detail than example problem 1.

CARE3MENU

Enter Desired Function: 1 cr

Stage Description Input

Stage Name: INERTIAL REF cr

Number of Beginning Modules in Stage: 3 cr

Minimum Number of Modules for Stage Operation: 2 cr

Number of Beginning Submodules per Module: 0 cr (default)

Minimum Number of Submodules for Module Operation: 0 cr (default)

Spare Submodules On-Line (T/F): T cr (default)

Set(s) of Modules Subject to Critical Pair Failures: cr (default)

Critical Fault Threshold: cr (default)

Number of Fault Handling Models Assigned to this Stage (opt.): 0 cr

Stage Name: PITCH RATE cr

Number of Beginning Modules in Stage: 3 cr

Minimum Number of Modules for Stage Operation: 2 cr

Number of Beginning Submodules per Module: 0 cr (default)

Minimum Number of Submodules for Module Operation: 0 cr (default)

Spare Submodules On-Line (T/F): T cr (default)

Set(s) of Modules Subject to Critical Pair Failures: cr (default)

Critical Fault Threshold: cr (default)

Number of Fault Handling Models Assigned to this Stage (opt.): 0 cr

Stage Name: COMPUTER cr

Number of Beginning Modules in Stage: 4 cr

Minimum Number of Modules for Stage Operation: 2 cr

Number of Beginning Submodules per Module: 0 cr (default)

Minimum Number of Submodules for Module Operation: 0 cr (default)

Spare Submodules On-Line (T/F): T cr (default)

Set(s) of Modules Subject to Critical Pair Failures: cr (default)

Critical Fault Threshold: cr (default)

Number of Fault Handling Models Assigned to this Stage (opt.): 0 cr

Stage Name: SECONDARY ACT cr

Number of Beginning Modules in Stage: 3 cr

Minimum Number of Modules for Stage Operation: 2 cr

Number of Beginning Submodules per Module: 0 cr (default)

Minimum Number of Submodules for Module Operation: 0 cr (default)

Spare Submodules On-Line (T/F): T cr (default)

Set(s) of Modules Subject to Critical Pair Failures: cr (default)

Critical Fault Threshold: cr (default)

Number of Fault Handling Models Assigned to this Stage (opt.): 0 cr

Stage Name: END cr

Enter Desired Function: C cr

FHM information is not entered in this model.

Fault Occurrence Models

Stage: **INERTIAL REF**

FHM Number: 1

Fault Type: (NONE) cr (default)

FOM (Weibull/Exponential): **EXPONENTIAL** cr (default)

Lambda = 1.5 E-5 cr

Omega = **1.0** cr (default)

Stage: **PITCH RATE**

FHM Number: 1

Fault Type: (NONE) cr (default)

FOM (Weibull/Exponential): **EXPONENTIAL** cr (default)

Lambda = 1.9 E-5 cr

Omega = **1.0** cr (default)

Stage: **COMPUTER**

FHM Number: 1

Fault Type: (NONE) cr (default)

FOM (Weibull/Exponential): **EXPONENTIAL** cr (default)

Lambda = 4.8 E-4 cr

Omega = **1.0** cr (default)

Stage: **SECONDARY ACT**

FHM Number: 1

Fault Type: (NONE) cr (default)

FOM (Weibull/Exponential): **EXPONENTIAL** cr (default)

Lambda = 3.7 E-5 cr

Omega = **1.0** cr (default)

Information Summary for Use in Checking System and Critical Pair Trees

Once again, this information is to be used for labeling the input events of the system fault tree (i.e., 1 to 4). The output or top event should be labeled 5 by the user.

Enter Desired Function: C cr

Ready to Begin Configuration Input

Type any key to continue... cr

System Fault Tree Input

Enter System Fault Tree Label

SYSTEM TREE EXS 2 cr

Enter Input Event ID Range, Output Gate ID Range

INPUT EVENT ID RANGE: 1 4

OUTPUT GATE ID RANGE: 5 5 cr (Remember to use spaces to separate the numbers.)

(In this problem, the range of inputs is 1 4 and the range of outputs is 5 5.)

Enter System Fault Tree Logic Block

5 Q 1 2 3 4 cr

(The program accepts either the letter O or the number 0 to represent an OR gate.)

(Critical pair tree information is not entered in this model.)

Output Control Options Input

(Select the default values for each parameter.)

Enter Desired Function: C cr

Runtime Control Options Input

Mission Time: 10 cr

Integration Steps: LOG cr (default)

Timebase (Hours, Minutes, Seconds, Days, Years): HOURS cr (default)

Cut Truncation Value = 0.1000000E-09 cr (default)

QPTRNC Value = 0.1000000E-01 cr (default)

NPSBRN Value = 20 cr (default)

CKDATA (T/F): T cr (default)

MODEL INPUT COMPLETE

Do you wish to review or alter this model (Y/N)? N cr

File Name Input

Enter File Name for Model Storage: EX2A.DAT cr

Verify Input (Y or N): Y cr

CARE3MENU—Menu Based Data Input for CARE III

Enter Desired Function: E cr

(Exit the program.)

FORTRAN STOP

3.5. Example Problem 2B Description

To illustrate the use of the module internal redundancy capability in CARE III Version VI, this example is presented. Each of the four redundant computers is composed of a central processor and memory. The processor controls memory access, effects configuration, and performs simple flight control tasks. The memory is composed of 40-bit lines supported by 4 redundant bit lines. A computer fails when either the central processor fails or less than 40 memory-bit lines are functioning correctly. The failure rate of each computer is $\lambda_c = 4.8 \times 10^{-4}$. This failure rate represents the combined failure rates of the processor and memory-bit lines such that

$$\lambda_c = \lambda_{cp} + 40\lambda_{mbl}$$

where λ_{cp} is the central processor failure rate of 2.4×10^{-4} and λ_{mbl} is the memory-bit lines failure rate of 5.0×10^{-6} .

To input example problem 2B, execute the CARE3MENU program and select

A—Alter an existing model

from the first menu screen. Then enter EX2A.DAT when asked for the file name. Use **Alter** in the **COMPUTER** stage to read

Stage Description Input

Stage Name: COMPUTER

Number of Beginning Modules in Stage: 4

Minimum Number of Modules for Stage Operation: 2

Number of Beginning Submodules per Module: 44 cr

Minimum Number of Submodules for Module Operation: 40 cr

Spare Submodules On-Line (T/F): T

Set(s) of Modules Subject to Critical Pair Failures: cr (default)

Critical Fault Threshold: cr (default)

Number of Fault Handling Models Assigned to this Stage (opt.):

Additionally, the fault occurrence model (FOM) screen for the computer stage will need to be altered. The program automatically initiates the INPUT mode for the computer FOM screen. Input the data as follows:

Fault Occurrence Models

Stage: COMPUTER

FHM Number: 1

**** MODULES ****

**** SUBMODULES ****

Fault Type: (NONE) cr

*** Fault Type: (NONE) cr**

FOM (Weibull/Exponential): EXP cr

*** FOM (Weibull/Exponential): EXP cr**

Lambda = 2.4E-04 cr

*** Lambda = 5.0E-06 cr**

Omega = 1.0 cr (default)

*** Omega = 1.0 cr (default)**

Fault Handling Models: (NONE)

Verify Input (Y or N): Y cr

All other information remains the same. Name the model EX2B.DAT and exit the CARE3MENU program.

Another level of modeling detail is achieved by this model. For more information about the module internal redundancy capability in CARE III Version VI, see reference 6.

4. Example Problem 3 Description

Example problem 3 further expands the complexity of the previous systems by including functional redundancy. The stages, however, are composed of one module per stage and there is no redundancy within the stages. Hazard rates are constant and, as in the previous two examples, fault handling is assumed to be perfect.

The functional block diagram of the entire system is shown in figure 4.1. Of particular interest in this example is the pitch augmented stability (PAS) function. This example computes the probability of failure of the PAS for a 10-hour mission.

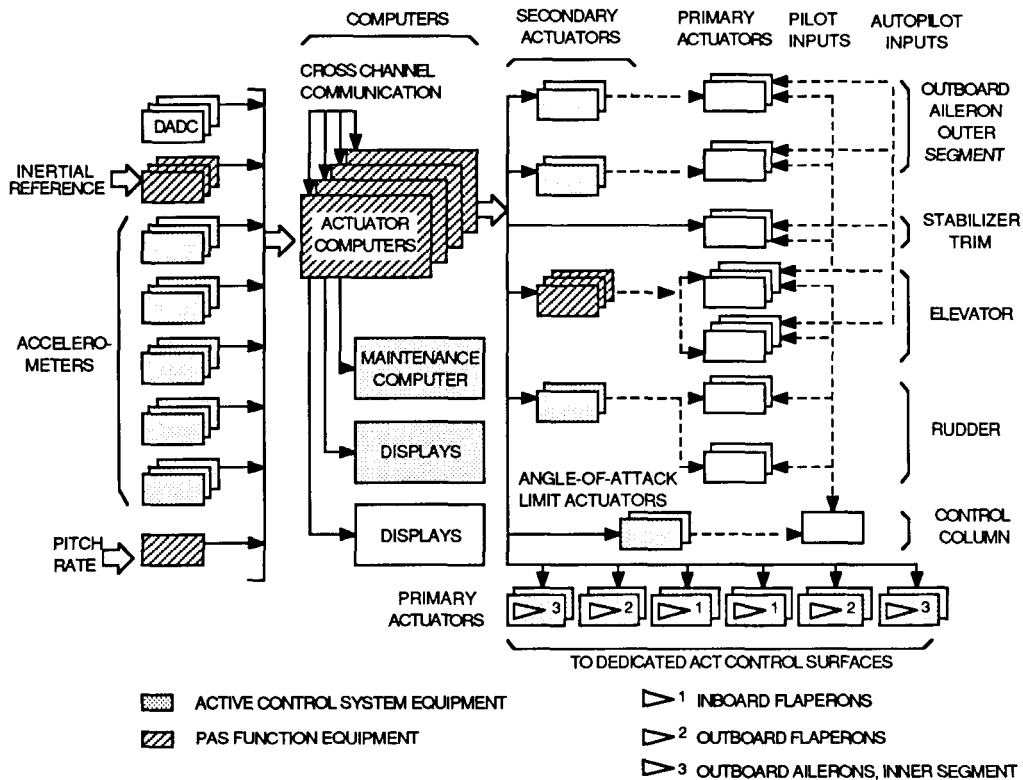

Figure 4.1. Example problem 3 functional block diagram.

4.1. System Failure Criteria

The PAS function fails if the computed data function fails *or* the elevator actuation function fails. The following lists ways these two functions may fail:

1. The computed data function fails if three of four sensor sets fail, or if the computation fails.
 - A. A sensor set fails when
 - a. computer A or inertial reference sensor A fails.
 - b. computer B or inertial reference sensor B fails.
 - c. computer C or inertial reference sensor C fails.
 - d. computer D or the pitch rate sensor fails.
 - B. The computation function fails if three of four computers fail.
2. The elevator actuator function, composed of four elements, fails when three of the four elements fail. The four elements are the actuator function (elevator math model¹), and three secondary actuators.
 - A. Secondary actuator A fails if computer A or actuator electronics A fails.
 - B. Secondary actuator B fails if computer B or actuator electronics B fails.
 - C. Secondary actuator C fails if computer C or actuator electronics C fails.
 - D. The elevator math model fails if three of the four computers fail.

¹ The computers perform both the computation function *and* the elevator math model computations.

4.2. Input Data for the Fault Occurrence Model

Computer (C) modules:

$$\lambda_A = 4.4 \times 10^{-4}$$

$$\lambda_B = 4.8 \times 10^{-4}$$

$$\lambda_C = 3.5 \times 10^{-4}$$

$$\lambda_D = 3.1 \times 10^{-4}$$

Inertial reference sensor (IRS) modules:

$$\lambda_A = 1.7 \times 10^{-5}$$

$$\lambda_B = 1.5 \times 10^{-5}$$

$$\lambda_C = 2.1 \times 10^{-5}$$

Pitch rate sensor (PRS) modules:

$$\lambda = 1.8 \times 10^{-5}$$

Actuator electronics (AE) modules:

$$\lambda_A = 3.6 \times 10^{-5}$$

$$\lambda_B = 3.1 \times 10^{-5}$$

$$\lambda_C = 3.7 \times 10^{-5}$$

4.3. System Tree

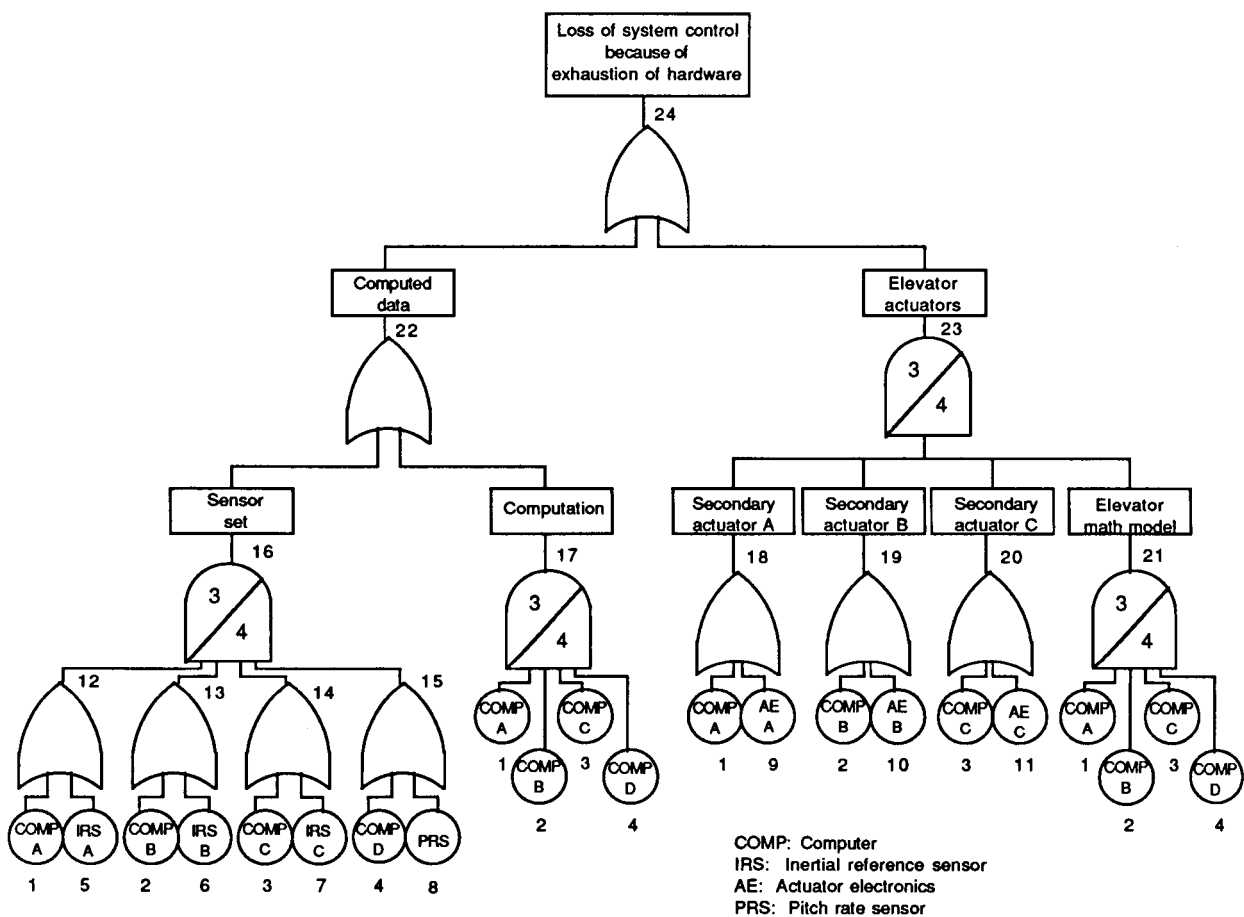

Figure 4.2. Example problem 3 system tree.

The computation function and elevator math model both fail when three of the four computers fail. From the tree in figure 4.2 it is evident that if the computation function fails, then the computed data branch fails and PAS function loss occurs. The inclusion of the elevator math model, therefore, is redundant and will not impact this system's probability of failure. However, it is included in the tree for the sake of clarity and completeness. The user may wish to remove the elevator math model from the tree and change the elevator actuators 3/4 gate to a 2/3 gate to verify that CARE III produces the same results.

4.4. Using the User-Friendly Interface

Preliminary:

The level of CARE3MENU screen detail has been reduced.

CARE3MENU—Menu Based Data Input for CARE III
Enter Desired Function: I cr

Stage Description Input

- Stage Name: COMPUTER A cr**
(Select defaults, specify 0 FHMs, and verify.)
- Stage Name: COMPUTER B cr**
(Select defaults, specify 0 FHMs, and verify.)
- Stage Name: COMPUTER C cr**
(Select defaults, specify 0 FHMs, and verify.)
- Stage Name: COMPUTER D cr**
(Select defaults, specify 0 FHMs, and verify.)
- Stage Name: INERTIAL SENSOR A cr**
(Select defaults, specify 0 FHMs, and verify.)
- Stage Name: INERTIAL SENSOR B cr**
(Select defaults, specify 0 FHMs, and verify.)
- Stage Name: INERTIAL SENSOR C cr**
(Select defaults, specify 0 FHMs, and verify.)
- Stage Name: PITCH RATE cr**
(Select defaults, specify 0 FHMs, and verify.)
- Stage Name: ACT ELECTRONICS A cr**
(Select defaults, specify 0 FHMs, and verify.)
- Stage Name: ACT ELECTRONICS B cr**
(Select defaults, specify 0 FHMs, and verify.)
- Stage Name: ACT ELECTRONICS C cr**
(Select defaults, specify 0 FHMs, and verify.)
- Stage Name: END cr**

Enter Desired Function: C cr

No FHM information is entered in this model. Once again, if the screen appears (indicating that the user did not specify 0 FHMs for all stages), enter PERMANENT as the fault type and select all defaults. Type END when the second screen appears. At least one **Fault Occurrence Models** screen will require the fault type to be specified. If the program then queries for more than one fault type for that stage, the user should type END to continue to the next stage.

Fault Occurrence Models

(For all the fault occurrence models below, select the defaults for the fault type, FOM (exponential default), and for omega (default = 1.0). The only value to be input is lambda.)

Stage: COMPUTER A
Lambda = 4.4 E-4 cr
(Verify)

Stage: COMPUTER B

Lambda = 4.8 E-4 cr

(Verify)

Stage: COMPUTER C

Lambda = 3.5 E-4 cr

(Verify)

Stage: COMPUTER D

Lambda = 3.1 E-4 cr

(Verify)

Stage: INERTIAL SENSOR A

Lambda = 1.7 E-5 cr

(Verify)

Stage: INERTIAL SENSOR B

Lambda = 1.5 E-5 cr

(Verify)

Stage: INERTIAL SENSOR C

Lambda = 2.1 E-5 cr

(Verify)

Stage: PITCH RATE

Lambda = 1.8 E-5 cr

(Verify)

Stage: ACT ELECTRONICS A

Lambda = 3.6 E-5 cr

(Verify)

Stage: ACT ELECTRONICS B

Lambda = 3.1 E-5 cr

(Verify)

Stage: ACT ELECTRONICS C

Lambda = 3.7 E-5 cr

(Verify)

**Information Summary for Use in Checking
System and Critical Pair Trees**

(Continue by typing C cr.)

**Ready to Begin Failure Configuration Input
Type any key to continue... cr**

System Fault Tree Input

Enter System Tree Label

SYSTEM TREE EX 3

Input Event ID Range: 1 11

Output Gate ID Range: 12 24

Enter System Fault Tree Logic Block

12 0 1 5 cr

13 0 2 6 cr

14 0 3 7 cr

15 0 4 8 cr

16 3 12 13 14 15 cr
17 3 1 2 3 4 cr
18 0 1 9 cr
19 0 2 10 cr
20 0 3 11 cr
21 3 1 2 3 4 cr
22 0 16 17 cr
23 3 18 19 20 21 cr
24 0 22 23 cr

(Two different logic gates are used in this example problem. The first gate is an OR gate and has been used in the past two examples. The second type of gate is the M/N ("M out of N") gate. For example, note that the fifth line reads **16 3 12 13 14 15 cr**. The first number is the gate output number. Following that is the gate type, in this case a $3/N$ gate. The number of gate inputs following the gate type is equal to N . By counting the inputs on this line, the user can easily see that this is a $3/4$ gate, with inputs numbered 12 to 15.)

No critical pair tree is entered in this model. If the **Critical Pairs Fault Tree Input** screen appears, type **END cr** for the fault tree label.

Output Control Options Input

(Select defaults and verify.)

Runtime Control Options Input

Mission Time: **10 cr**

(Select defaults and verify.)

MODEL INPUT COMPLETE

Do you wish to review or alter this model (Y/N)? **N cr**

File Name Input

Enter File Name for Model Storage: **EX3.DAT cr**

Verify Input (Y or N): **Y cr**

CARE3MENU—Menu Based Data Input for CARE III

Enter Desired Function: **E cr**

(Exit the program.)

FORTRAN STOP

4.5. Comments

For these first three example problems, the fault type (NONE) has been assigned to each of the stages. CARE3MENU has automatically generated one fault handling model and stored the FHM data in the CARE III input file. Because the FHM single-point failure parameter C equals 1.0 and because there are no critical pair trees (and therefore the CARE III "QSUM" probability equals zero), the problem is reduced to a classic fault tree problem and is solved as such.

5. Example Problem 4A Description

Example problem 4A introduces the fault handling model for permanent faults only. The system structure is identical to that of example problem 2A (see fig. 5.1). However, in example problem 2A the system can fail only if hardware redundancy requirements are not met. In addition to failure by lack of hardware, this example allows the possibility of system failure because of a single-point failure in the computer stage. Other stages are assumed to have perfect coverage.

The computer stage checks for computer faults by majority voting on all outputs to the actuator stage. If a failed computer is successfully detected, it is isolated from the system by the remaining good units. This process continues until a majority vote cannot be accomplished, that is, when less than two computers survive. At this point the system fails because the system contains no functional redundancy. (See system tree.)

The single-fault model is shown in section 5.4 and includes four parameters not yet used in the example problems. The computers detect faults by executing periodic or random self-test programs. The fault detection rate is given by $\delta(t')$. The rate at which errors are generated from the permanent faults is given by $\rho(t')$, and the rate of error detection is given by $\epsilon(\tau)$. The failure parameter C is the proportion of detected errors from which the system is able to recover.

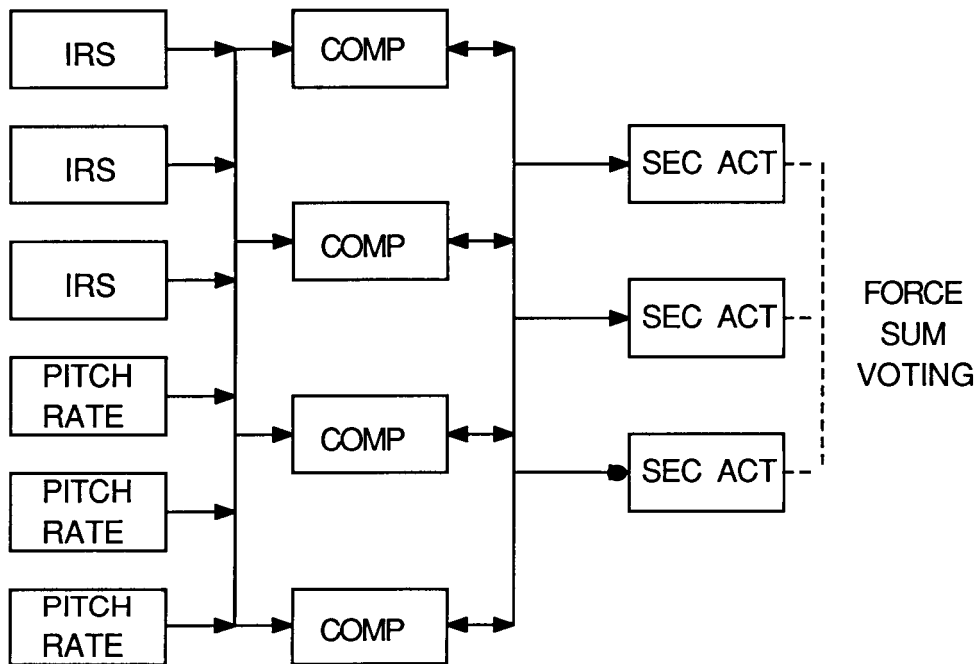

Figure 5.1. Example problem 4A functional block diagram.

5.1. System Failure Criteria

The system failure criteria for example problem 4A are as follows:

1. The system fails if any stage fails.
2. A single-point failure in the computer stage causes system failure.
3. The inertial reference sensor stage fails if two out of three modules fail.
4. The pitch rate stage fails if two out of three modules fail.
5. The computer stage fails if three out of four modules fail.
6. The secondary actuator stage fails if two out of three modules fail.

5.2. Input Data

For the Fault Occurrence Model:

Inertial reference sensor modules:	$\lambda = 1.5 \times 10^{-5}$
Pitch rate sensor modules:	$\lambda = 1.9 \times 10^{-5}$
Computer modules:	$\lambda = 4.8 \times 10^{-4}$
Secondary actuator modules:	$\lambda = 3.7 \times 10^{-5}$

For the Permanent Fault Handling Model:

- Self-test rate: $\delta(t') = 360$ detections per hour
 - Random test (problem 4A): Exponential
 - Periodic test (problem 4B): Uniform
- Error generation rate: $\rho(t') = 180$ errors per hour
 - Random test (problem 4A): Exponential
 - Periodic test (problem 4B): Uniform
- Error detection rate: $\varepsilon(\tau) = 3600$ detections per hour
 - Random test (problem 4A): Exponential
 - Periodic test (problem 4B): Uniform
- Error recovery probability: $C = 0.999$

Problem 4A uses the exponential distribution (default) to describe the parameters $\delta(t')$, $\rho(t')$, and $\varepsilon(\tau)$. To see the effects of solving the problem using uniform distributions, problem 4B should be executed.

5.3. System Tree

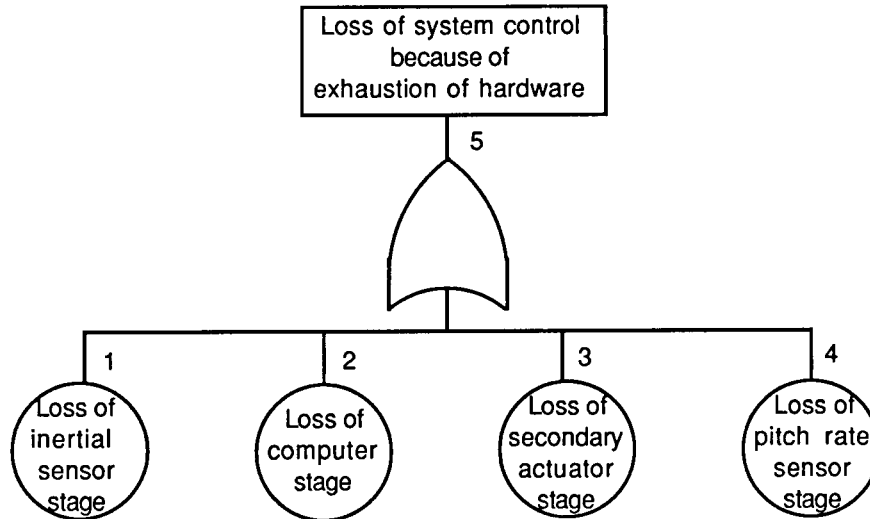

Figure 5.2. Example problem 4A system tree.

5.4. Single-Fault Model

The transition from the A state to the A_D state represents the detection of a fault before the fault generates errors, and the transition from A to A_E represents an active fault that generates errors. With the rate $\varepsilon(\tau)$ and probability C , the system recovers to the A_D state; with rate $\varepsilon(\tau)$ and probability $(1 - C)$, a single-point failure causes system failure (F state).

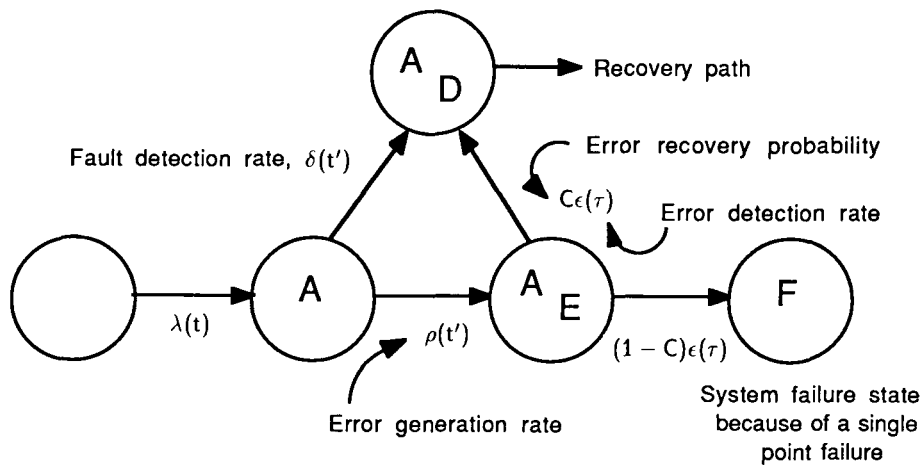

Figure 5.3. Example problem 4A permanent single-fault model.

5.5. Using the User-Friendly Interface

CARE3MENU—Menu Based Data Input for CARE III

Enter Desired Function: I cr

Stage Description Input

Stage Name: INERTIAL REF cr

Number of Beginning Modules in Stage: 3 cr

Minimum Number of Modules for Stage Operation: 2 cr
 (Select defaults, specify 0 FHM's, and verify.)

Stage Name: PITCH RATE cr

Number of Beginning Modules in Stage: 3 cr

Minimum Number of Modules for Stage Operation: 2 cr
 (Select defaults, specify 0 FHM's, and verify.)

Stage Name: COMPUTER cr

Number of Beginning Modules in Stage: 4 cr

Minimum Number of Modules for Stage Operation: 2 cr
 (Select defaults, specify 1 FHM, and verify.)

Stage Name: SECONDARY ACT cr

Number of Beginning Modules in Stage: 3 cr

Minimum Number of Modules for Stage Operation: 2 cr
 (Select defaults, specify 0 FHM's, and verify.)

Stage Name: END cr

(Continue to the next screen.)

Fault Handling Models

(The fault type selections in this example are "PERMANENT" and "(NONE)." See section 5.6 for additional information about these FHM's and the CARE III input file.)

Fault Type: PERMANENT cr

Alpha = 0.0 cr (default) **(Exponential)**

Beta = 0.0 cr (default) **(Exponential)**

Delta = 360 cr

Delta FHM: EXPONENTIAL cr (default)

Rho = 180 cr

Rho FHM: EXPONENTIAL cr (default)

Epsilon = 3600 cr (default)

Epsilon FHM: EXPONENTIAL cr

Pa = 1.000000 cr (default)

Pb = 0.0 cr (default)

C = .999 cr (default)

Fault Type: END cr

(Continue to the next screen.)

Fault Occurrence Model

Stage: INERTIAL REF

FHM Number: 1

Fault Type: (NONE) cr (default)

Lambda = 1.5 E-5 cr

(Select the appropriate defaults and verify.)

Stage: PITCH RATE

FHM Number: 1

Fault Type: (NONE) cr (default)

Lambda = 1.9 E-5 cr

(Select the appropriate defaults and verify.)

Stage: COMPUTER

FHM Number: 1

Fault Type: PERMANENT cr

Lambda = 4.8 E-4 cr

(Select the appropriate defaults and verify.)

Stage: SECONDARY ACT

FHM Number: 1

Fault Type: (NONE) cr (default)

Lambda = 3.7 E-5 cr

(Select the appropriate defaults and verify.)

Verify the information summary against the system tree and continue to the tree entry.

System Fault Tree Input

Enter System Tree Label

SYSTEM TREE EX 4A

Input Event ID Range: 1 4

Output Gate ID Range: 5 5 cr

Enter System Fault Tree Logic Block

5 0 1 2 3 4 cr

Critical Pairs Fault Tree Input

END cr

(No critical pair tree for this model.)

(Continue to the next screen.)

Output Control Options Input

(Select defaults and verify.)

(Continue to the next screen.)

Runtime Control Options Input

Mission Time: 10 cr

(Select defaults and verify.)

*****MODEL INPUT COMPLETE*****

Do you wish to review or alter this model (Y/N)? N cr

(Store the file as EX4A.DAT and exit the program.)

FORTRAN STOP

5.6. Example Problem 4B Description

The effects of the uniform distribution for the parameters $\delta(t')$, $\rho(t')$, and $\varepsilon(\tau)$ can be observed by altering the file EX4A.DAT and executing the CARE III program. When the **Fault Handling Models** screen for the **PERMANENT** fault type is reached, **ALTER** the screen and change the Delta FHM, Rho FHM, and Epsilon FHM from **EXPONENTIAL** to **UNIFORM**.

Fault Handling Models

Fault Type: **PERMANENT** cr

Alpha = 0.0 cr

(Exponential)

Beta = 0.0 cr

(Exponential)

Delta = 360 cr

Delta FHM: **UNIFORM** cr

Rho = 180 cr

Rho FHM: **UNIFORM** cr

Epsilon = 3600 cr

Epsilon FHM: **UNIFORM** cr

Pa = 1.000000 cr

Pb = 0.0 cr

C = .999 cr

Continue to review the file until the **Fault Handling Model Accuracy** screen is reached. This screen only appears when the user selects at least one **UNIFORM** distribution for the fault handling function. Select the defaults for the screen as shown below.

Fault Handling Model Accuracy

DBLDF (Doubling Step Difference) = 0.5000000E-01 cr (default)

TRUNC (Coverage Function Truncation) = 0.1000000E-03 cr (default)

The two parameters DBLDF and TRUNC control the accuracy of the CARE III algorithm. For more information, see reference 2.

Continue to review the model. Name this model EX4B.DAT and exit the program.

5.7. Comments

When the user indicates 0 FHM's to be assigned to a stage, the CARE3MENU program creates an FHM entitled "(NONE)." The user then may enter only four additional FHM's to bring the total FHM's for the model to five *if* a (NONE) FHM is desired. It is important to note that the user may indicate 0 FHM's for one or more stages, but if five FHM's are entered, the (NONE) FHM is automatically overwritten by the fifth FHM.

The names chosen to describe the stages and FHM's are intended to be descriptive. However, the CARE3MENU program simply verifies that no other stage or FHM has the same name and then stores the name as a character string. No intuitive interpretation of the name is made. Thus, the FHM name "PERMANENT" in this model could have been shortened to "PERM," or shortened simply to "P," or given any other (unique) string value. The stage and FHM names (written into the STGNAMES and FHMNAMES NAMELIST paragraphs, respectively) are included in the CARE III input file and are used if the file is later altered by a CARE3MENU session. The STGNAMES and FHMNAMES NAMELIST paragraphs are disregarded by the CARE III program.

6. Example Problem 5 Description

Example problem 5 (fig. 6.1) expands on example problem 4 by the addition of redundancy in the system tree and a more detailed single-fault model. The redundant system tree now includes a backup to the digital computer stage. The backup is a bare-bones, limp-back analog system that is switched in when the digital computer stage fails.

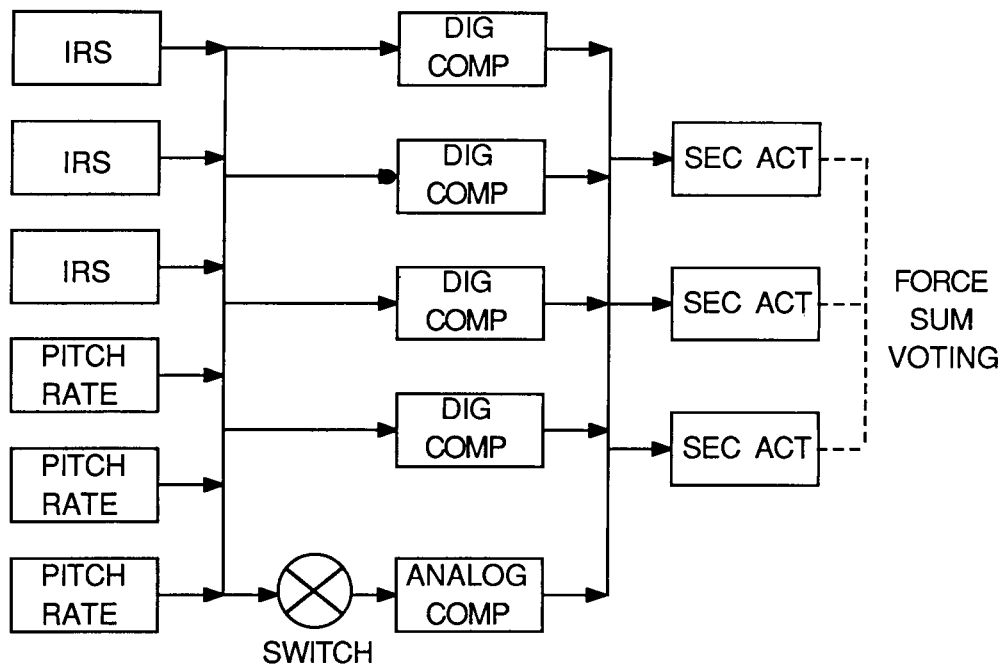

Figure 6.1. Example problem 5 functional block diagram.

The single-fault model in section 6.4 is further expanded to include, for the computer stage only, the consideration of transients and intermittents in addition to the previously defined permanent fault model. All other factors, such as mission length and hazard distributions, are unchanged. The inclusion of transients and intermittents allows the user to include another level of modeling sophistication that considers systems architectures which can differentiate between permanent, transient, and intermittent module failures. Proper identification of the failure type causes a different system response for purging failed modules. The addition of two probabilities, P_A and P_B , enables that capability.

The parameter P_A is the probability that a module with a nonbenign fault must be retired from service, and therefore $1 - P_A$ is the probability that the module is to be returned to service following the detection of the fault. The assignment of $0 < P_A < 1$ enables the modeling of transients which do not cause a module to be purged, thus allowing the transient to vanish. The risk of not purging a faulty module (for example, a module with an intermittent or permanent fault) is weighed against the risk of purging a module with a short-lived transient. The probability P_B has a similar meaning except the risk involves benign faults as opposed to active faults.

6.1. System Failure Criteria

The system failure criteria for example problem 5 are as follows:

1. The system fails if the inertial reference sensor, pitch rate sensor, or actuator stage fails, or if the digital computer stage fails and the analog computer or transfer switch fails.
2. A single-point failure in the computer stage causes system failure.
3. The inertial reference sensor stage fails if two out of three modules fail.
4. The pitch rate stage fails if two out of three modules fail.
5. The computer stage fails if three out of four modules fail.
6. The secondary actuator stage fails if two out of three modules fail.

6.2. Input Data

For the Fault Occurrence Model:

Inertial reference sensor modules:	$\lambda = 1.5 \times 10^{-5}$
Pitch rate sensor modules:	$\lambda = 1.9 \times 10^{-5}$
Digital computer modules (permanent):	$\lambda = 4.8 \times 10^{-4}$
Digital computer modules (transient):	$\lambda = 7.2 \times 10^{-3}$
Digital computer modules (intermittent):	$\lambda = 3.3 \times 10^{-4}$
Transfer switch module:	$\lambda = 1.7 \times 10^{-10}$
Analog computer module:	$\lambda = 2.3 \times 10^{-9}$
Secondary actuator modules:	$\lambda = 3.7 \times 10^{-5}$

For the Single-Fault Handling Model:

Self-test rate: $\delta(t') = 360$ detections per hour

Random test: Exponential

Error detection rate: $\varepsilon(\tau) = 3600$ detections per hour

Random test: Exponential

Error generation rate: $\rho(t') = 180$ errors per hour

Random pattern: Exponential

Error recovery probability: $C = 0.999$

Transient duration rate α : 3.6×10^4

Intermittent duration rate α : 2.1×10^3

Intermittent benign-to-active rate β : 3.0×10^3

Retire module (active fault) probability P_A : 0.9

Retire module (benign fault) probability P_B : 0.1

6.3. System Tree

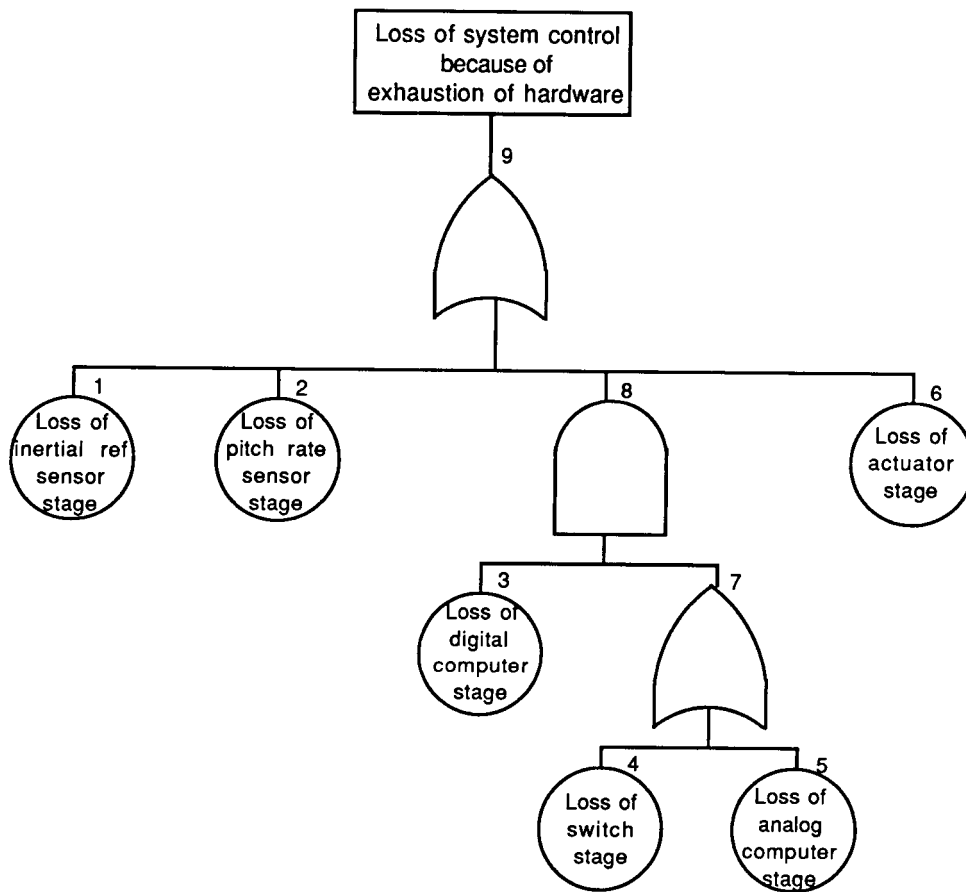

Figure 6.2. Example problem 5 system tree.

6.4. Single-Fault Model

The general single-fault model (fig. 6.3) includes all the CARE III FHM parameters. In example problem 5, four fault types are described: (NONE), PERMANENT, TRANSIENT, and INTERMITTENT. When α and β equal zero, the general single-fault model reduces to a permanent single-fault model, as shown in figure 5.3. Likewise, a model with $\alpha > 0$ and $\beta = 0$ represents a transient single-fault model. The intermittent single-fault model has $\alpha > 0$ and $\beta > 0$. The "(NONE)" FHM has one transition in the model, from the A to A_D state. All other transitions are disabled by setting $\rho(t') = \alpha = 0$ and $P_A = 1.0$. The B , B_D , and B_E states represent, respectively, a benign fault, a detected benign fault, and a fault that has produced errors before it becomes benign.

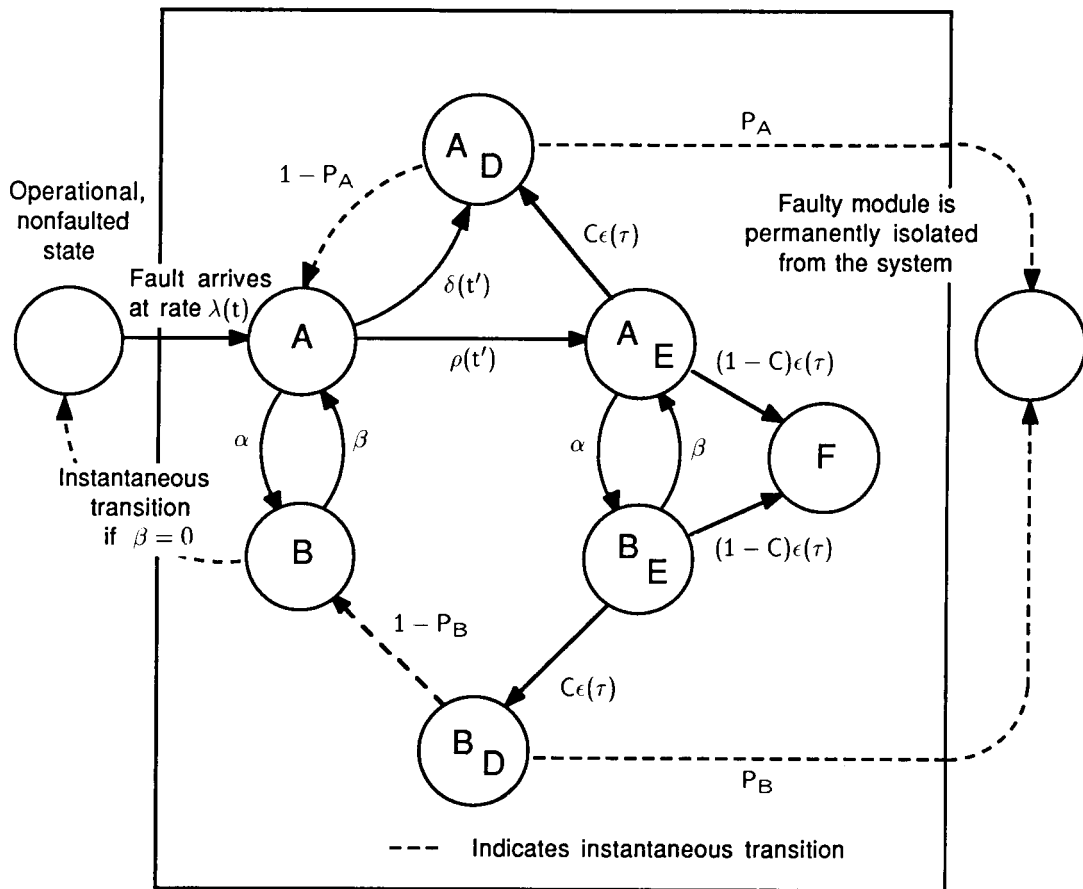

Figure 6.3. Example problem 5 general single-fault model.

6.5. Using the User-Friendly Interface

Stage Description Input

Enter the CARE3MENU as in the previous examples. Enter the stage names, the number of beginning modules, and the minimum number of modules for stage operation as in example problem 4. The values are given below.

Stage name	Beginning modules	Minimum modules	Beginning submodules	Number of FHM's
<u>INERTIAL REF</u>	<u>3</u>	<u>2</u>	<u>0</u>	<u>0</u>
<u>PITCH RATE</u>	<u>3</u>	<u>2</u>	<u>0</u>	<u>0</u>
<u>DIGITAL COMPUTER</u>	<u>4</u>	<u>2</u>	<u>0</u>	<u>3</u>
<u>SWITCH</u>	<u>1</u>	<u>1</u>	<u>0</u>	<u>0</u>
<u>ANALOG COMPUTER</u>	<u>1</u>	<u>1</u>	<u>0</u>	<u>0</u>
<u>SECONDARY ACTUATOR</u>	<u>3</u>	<u>2</u>	<u>0</u>	<u>0</u>

Fault Handling Models

The fault types and their associated parameters are given below.

Fault type	Parameter	Value	Distribution
<u>PERMANENT</u>	Delta =	<u>360</u>	EXPONENTIAL
	Rho =	<u>180</u>	EXPONENTIAL
	Epsilon =	<u>3600</u>	EXPONENTIAL
	C =	<u>.999</u>	
<u>TRANSIENT</u>	Alpha =	<u>3.6 E4</u>	(Exponential)
	Beta =	<u>0.0</u>	(Exponential)
	Delta =	<u>360</u>	EXPONENTIAL
	Rho =	<u>180</u>	EXPONENTIAL
	Epsilon =	<u>3600</u>	EXPONENTIAL
	Pa =	<u>.9</u>	
	C =	<u>.999</u>	
<u>INTERMITTENT</u>	Alpha =	<u>2.1 E3</u>	(Exponential)
	Beta =	<u>3.0 E3</u>	(Exponential)
	Delta =	<u>360</u>	EXPONENTIAL
	Rho =	<u>180</u>	EXPONENTIAL
	Epsilon =	<u>3600</u>	EXPONENTIAL
	Pa =	<u>.9</u>	
	Pb =	<u>.1</u>	
	C =	<u>.999</u>	

Alpha and beta will always be exponentially distributed, while delta, rho, and epsilon distributions can be described by either the exponential *or* the uniform distribution. For more information about these fault types, see reference 2.

Fault Occurrence Models

For each stage enter the appropriate fault type(s) and lambda value(s). Select the defaults for the FOM (exponential default) and for omega (default = 1.0).

Stage	Fault type	Lambda
INERTIAL REF	(NONE)	<u>1.5 E-5</u>
PITCH RATE	(NONE)	<u>1.9 E-5</u>
DIGITAL COMPUTER	<u>PERMANENT</u>	<u>4.8 E-4</u>
	<u>TRANSIENT</u>	<u>7.2 E-3</u>
	<u>INTERMITTENT</u>	<u>3.3 E-4</u>
SWITCH	(NONE)	<u>1.7 E-10</u>
ANALOG COMPUTER	(NONE)	<u>2.3 E-9</u>
SECONDARY ACT	(NONE)	<u>3.7 E-5</u>

Verify the information summary against the system tree and continue to the tree entry.

System Fault Tree Input

Enter System Tree Label

SYSTEM TREE EX 5

Input Event ID Range: 1 6
Output Gate ID Range: 7 9 cr

Enter System Fault Tree Logic Block

7 O 4 5 cr
8 A 3 7 cr
9 O 1 2 8 6 cr

(The *A* represents an AND gate.)

Critical Pairs Fault Tree Input

Enter Fault Tree Label

END cr

Output Control Options Input

(Select defaults and verify.)

Runtime Control Options Input

Mission Time: 10 cr
(Select defaults and verify.)

*****MODEL INPUT COMPLETE*****

Do you wish to review or alter this model (Y/N)? N cr

(Store the file with the name EX5.DAT and exit the program.)

FORTRAN STOP

7. Example Problem 6 Description

Example problem 6 (fig. 7.1) introduces two more CARE III capabilities. The first is the modeling of critical pair failures within stages, and the second is the modeling of hot spares. In this example, a critical pair failure is defined for the digital computer stage only. This problem allows for both single-point failures and critically coupled faults which result in system failure.

To illustrate the critically coupled fault model, the digital computer stage is configured as a triplex with one hot spare in lieu of the quadraplex system used in example problem 4. The triplex computers randomly execute a self-test program to detect faults, and the hot spare is constantly being flexed by randomly replacing a triad module with the spare. The replaced module then becomes the hot spare. A critically coupled failure is assumed to occur if two undetected faults and/or errors coexist in two different computers in the triad. Such a condition causes immediate system failure.

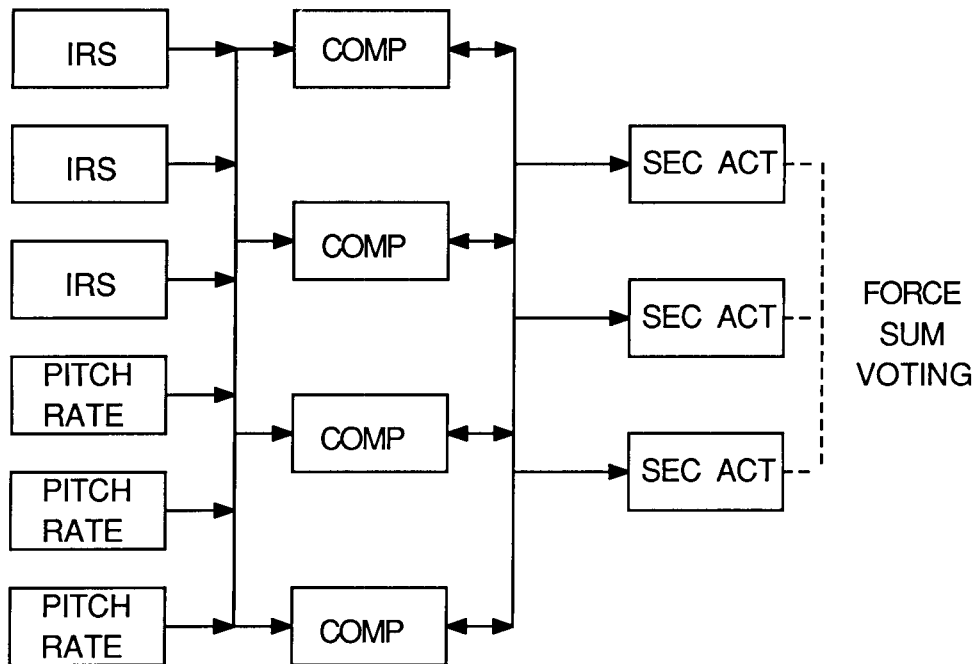

Figure 7.1. Example problem 6 functional block diagram.

7.1. System Failure Criteria

The system failure criteria for example problem 6 are as follows:

1. The system fails if any stage fails.
2. A single-point failure in the computer stage causes system failure.
3. The system fails if a critically coupled failure occurs in the computer stage.
4. The inertial reference sensor stage fails if two out of three modules fail.
5. The pitch rate sensor stage fails if two out of three modules fail.
6. The computer stage fails if three out of four modules fail.
7. The secondary actuator stage fails if two out of three modules fail.

7.2. Input Data

For the Fault Occurrence Model:

Inertial reference sensor modules:	$\lambda = 1.5 \times 10^{-5}$
Pitch rate sensor modules:	$\lambda = 1.9 \times 10^{-5}$
Computer modules:	$\lambda = 4.8 \times 10^{-4}$
Secondary actuator modules:	$\lambda = 3.7 \times 10^{-5}$

For the Single-Fault Handling Model:

- Self-test rate: $\delta(t') = 360$ detections per hour
 Random test: Exponential
- Error detection rate: $\varepsilon(\tau) = 3600$ detections per hour
 Random test: Exponential

Error generation rate: $\rho(t') = 180$ errors per hour
 Random pattern: Exponential
 Error recovery probability: $C = 0.999$

7.3. System Tree

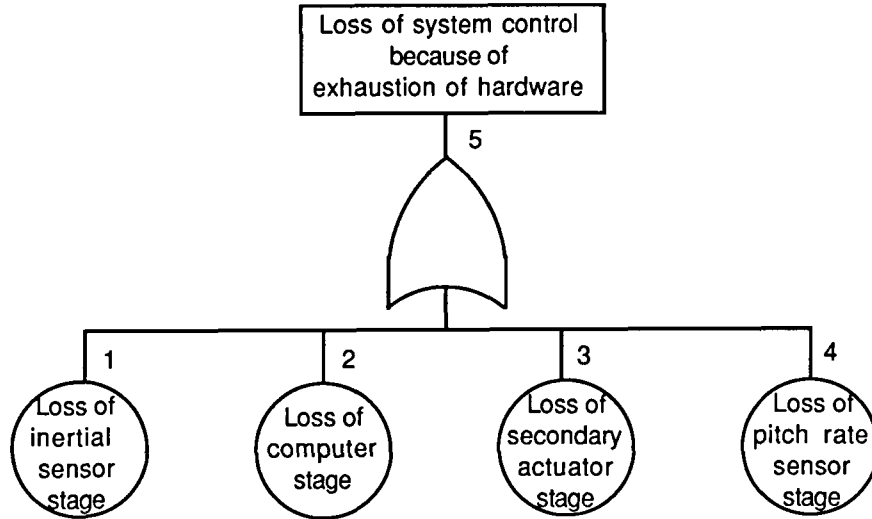

Figure 7.2. Example problem 6 system tree.

7.4. Single-Fault Model

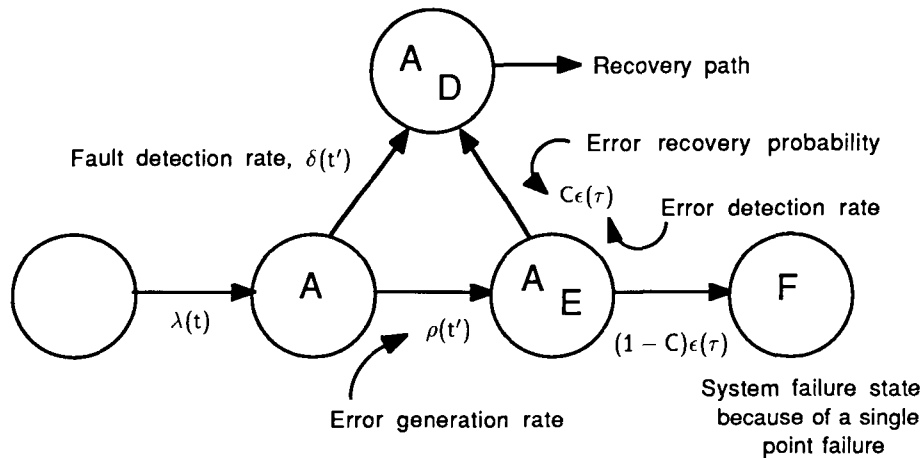

Figure 7.3. Example problem 6 permanent single-fault model.

7.5. Critical Pair Tree

A critical pair tree (fig. 7.4) identifies the modules within the system that are critically coupled. In this example, computers 1 to 3 are initially operational and subject to the critical pair failure criterion. Computer 4 is treated as a hot spare which simply vanishes if it fails as a spare. When an undetected fault or error exists in a member of the voting trio and another member of the trio also

becomes faulty, the system is assumed to fail because of the presence of two simultaneously faulty modules in the voting triad.

The line **Set(s) of Modules Subject to Critical Pair Failures** for the computer stage indicates that the fourth computer (or module) is a spare and therefore does not critically couple with the other computers. Equivalently, therefore, the 2/3 gate could have been a 2/4 gate, with computer 4 included as an input. In CARE III, the line **Set(s) of Modules...** (the CARE III input file "NOP" parameter) overrides the critical pair gate specification.

If a single member of the voting trio fails and fault handling is successful, the spare, if it is still operational, replaces the failed voting member. A second failure leaves two remaining in-use computers which are still subject to a critical pair failure. The next failure, resulting in one in-use computer remaining, causes the computer stage to fail since the success criterion of two out of four is not met for stage survival. In this example, loss of the computer stage causes system failure because there is no functional redundancy in the system tree.

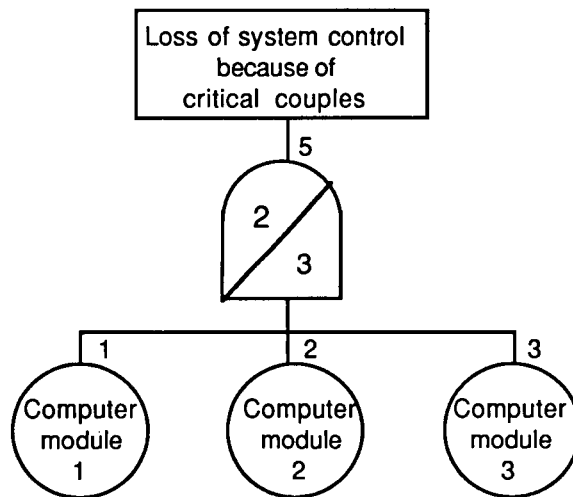

Figure 7.4. Example problem 6 critical pair tree.

7.6. Using the User-Friendly Interface

Preliminary:

For this example, the critical pair tree input screens are shown with detail.

Stage Description Input

Enter the CARE3MENU program as in the previous examples. Enter the stage names and values given below.

(For the computer stage, enter a 3 when the system requests "**Set(s) of Modules Subject to Critical Pair Failures.**")

Stage name	Beginning modules	Minimum modules	Beginning submodules	Set(s) of modules	Number of FHM's
<u>INERTIAL REF</u>	<u>3</u>	<u>2</u>	<u>0</u>		<u>0</u>
<u>PITCH RATE</u>	<u>3</u>	<u>2</u>	<u>0</u>		<u>0</u>
<u>COMPUTER</u>	<u>4</u>	<u>2</u>	<u>0</u>	<u>3</u>	<u>1</u>
<u>SECONDARY ACT</u>	<u>3</u>	<u>2</u>	<u>0</u>		<u>0</u>

Fault Handling Models

Enter the fault type used in this problem as listed below.

Fault type	Parameter	Value	Distribution
<u>PERMANENT</u>	Delta =	<u>360</u>	EXPONENTIAL
	Rho =	<u>180</u>	EXPONENTIAL
	Epsilon =	<u>3600</u>	EXPONENTIAL
	C =	<u>.999</u>	

Fault Occurrence Models

For all the fault occurrence models below, select the defaults for the FOM (exponential default) and for omega (default = 1.0). The only values to be input are fault type and lambda.

Stage	Fault type	Lambda
INERTIAL REF	(NONE)	<u>1.5 E-5</u>
PITCH RATE	(NONE)	<u>1.9 E-5</u>
COMPUTER	<u>PERMANENT</u>	<u>4.8 E-4</u>
SECONDARY ACT	(NONE)	<u>3.7 E-5</u>

Verify the information summary against the system tree and continue to tree entry.

System Fault Tree Input

Enter System Tree Label

SYSTEM TREE EX 6 cr

Input Event ID Range: 1 4

Output Gate ID Range: 5 5 cr

Enter System Fault Tree Logic Block

5 0 1 2 3 4 cr

Critical Pairs Fault Tree Input

Enter Fault Tree Label

CRITICAL PAIRS TREE EX 6 cr

Enter Module and Logic Range ID

1 4 5 5 cr

(This input describes the input range and output range. It is conceptually the same as the system tree lines **Input Event ID Range** and **Output Gate ID Range**.)

Enter Module Unit to Stage Association

3 1 4 cr

END cr

(This input indicates that inputs numbered 1 to 4 are the modules belonging to stage 3. Though all modules are not used in the tree, all four must be included in the line.)

Enter Logic Gate ID

5 2 1 2 3 cr

(Because the user indicated the range of outputs in the line above, the computer prompts for each output line by line. The first number or letter input by the user should be the gate type, where the allowable gates are the OR (O), two-input AND (A), or 2/N (2) gates. The critical pair tree should never be constructed so that one or more than two module failures cause an output from the topmost gate. Therefore, the AND gate is restricted to two inputs, and the M/N gate is reduced to the more restrictive 2/N gate. Finally, all inputs to the gate follow the gate type specification. In this example, the 2/N gate has three inputs, numbered 1, 2, and 3.)

Enter Fault Tree Label

END cr (There are no more critical pair trees to be input.)

Output Control Options Input

(Select defaults and verify.)

Runtime Control Options Input

Mission Time: 10 cr

(Select defaults and verify.)

*****MODEL INPUT COMPLETE*****

Do you wish to review or alter this model (Y/N)? N cr

(Store the file as EX6.DAT and exit the CARE3MENU program.)

FORTRAN STOP

8. Example Problem 7 Description

Example problem 7 (fig. 8.1) expands the analysis of the system in example problem 6 to study the effects of critical pair failures across stages as well as within a stage. To illustrate critical pair failures across stages, another stage is included in this analysis and added to the problem description of example problem 6. The new stage is the computer (C) bus, which enables communication between computers. The C-bus stage is composed of four buses; the failure of three or more buses causes the system to fail. Each bus transmits data from one computer to the remaining three computers. The computers pass results via the buses and vote the information before transmitting signals to the actuators.

One bus, which initially transmits data from the spare computer, is a hot spare and is not subject to critical pair failures. The three in-use buses, however, are susceptible to critical pair failures. Once an error is detected, a test is executed to indicate whether the fault is in the bus or the computer. The appropriate module is then isolated from the system. Note that a fault in one of the triad computers and a fault in one of the two triad buses which is not connected to the faulted computer precludes a correct majority vote at the receiving end of the triplex bus. This cross coupling of failures in two different stages (i.e., computer and bus) is a critically coupled failure across stages.

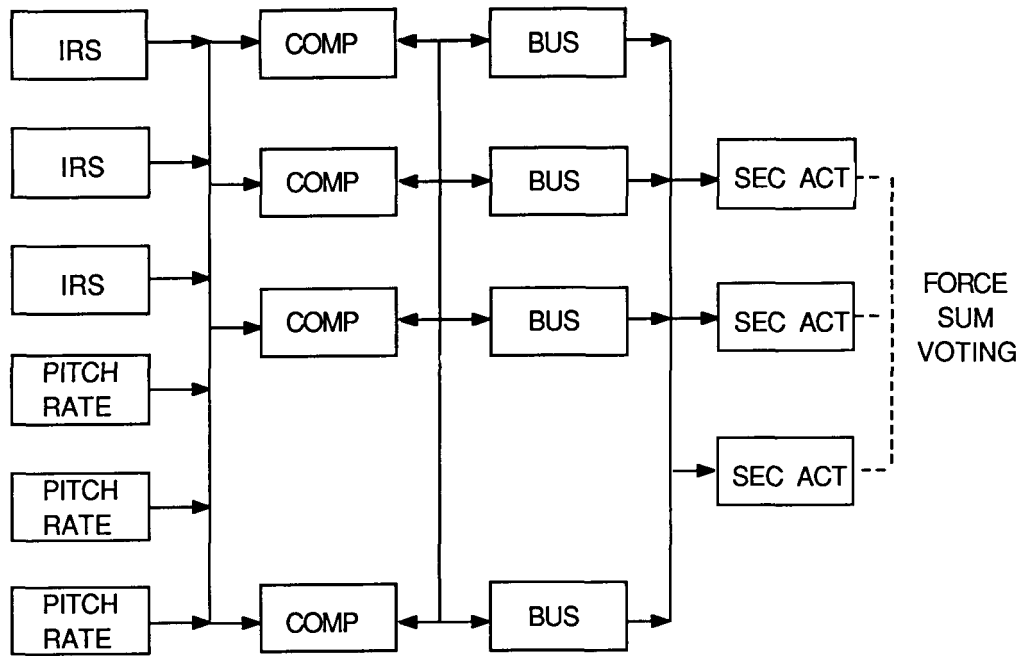

Figure 8.1. Example problem 7 functional block diagram.

8.1. System Failure Criteria

The system failure criteria for example problem 7 are as follows:

1. The system fails if any stage fails.
2. A single-point failure in the computer stage causes system failure.
3. The system fails if a critically coupled failure occurs in the computer stage, in the bus stage, or across these stages.
4. The inertial reference sensor stage fails if two out of three modules fail.
5. The computer stage fails if three out of four modules fail.
6. The bus stage fails if three out of four modules fail.

8.2. Input Data

For the Fault Occurrence Model:

Inertial reference sensor modules:	$\lambda = 1.5 \times 10^{-5}$
Pitch rate sensor modules:	$\lambda = 1.9 \times 10^{-5}$
Computer modules:	$\lambda = 4.8 \times 10^{-4}$
Secondary actuator modules:	$\lambda = 3.7 \times 10^{-5}$
Computer buses:	$\lambda = 2.7 \times 10^{-6}$

For the Single-Fault Handling Model:

Self-test rate:

Computer stage: $\delta(t') = 360$ detections per hour

Computer bus stage: $\delta(t') = 1.0 \times 10^4$ detections per hour

Error generation rate:

Computer stage: $\rho(t') = 180$ errors per hour

Computer bus stage: $\rho(t') = 0$ errors per hour

Error detection rate:

Computer stage: $\epsilon(\tau) = 3600$ detections per hour

Computer bus stage: $\epsilon(\tau) = 0$ detections per hour

Error recovery probability:

Computer stage: $C = 0.999$

Computer bus stage: $C = 1.0$

8.3. System Tree

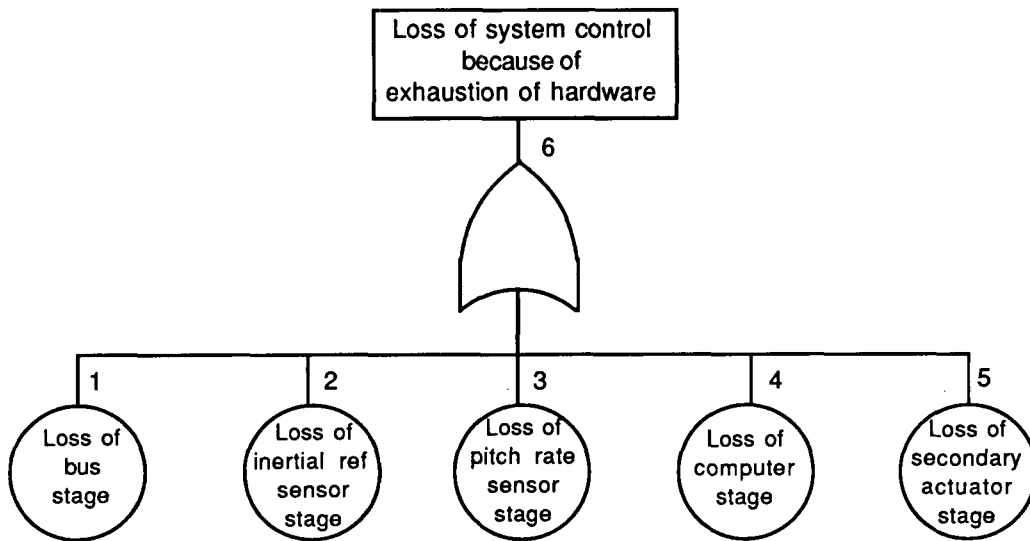

Figure 8.2. Example problem 7 system tree.

8.4. Single-Fault Model

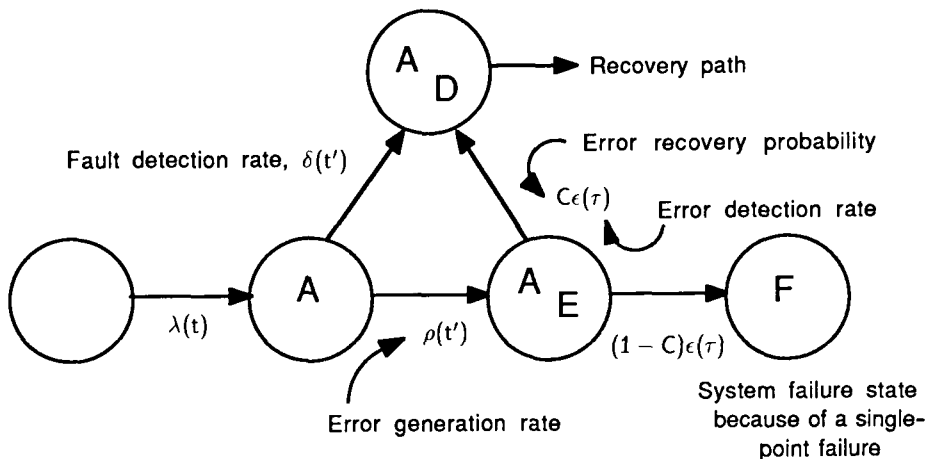

Figure 8.3. Example problem 7 permanent single-fault model.

8.5. Critical Pair Tree

The 2/3 gate with output 15 models the computer stage critically coupled failure. (See fig. 8.4.) The 2/3 gate with output 16 models the C-bus stage critically coupled failure. Once again, a 2/4 gate would have produced equivalent results. (See the discussion in section 7.5.) The OR gate (with output 17) and all lower connecting gates model critical couples across the computer and C-bus stages. For example, if computers 2 or 3 become faulty and C-bus 5 becomes faulty, the buses have bad data on two of the three in-use buses even though only one bus has failed. This critical couple causes the system to fail. Outputs 13 and 14 and lower level gates take into account the other combinations of computer and C-bus faults.

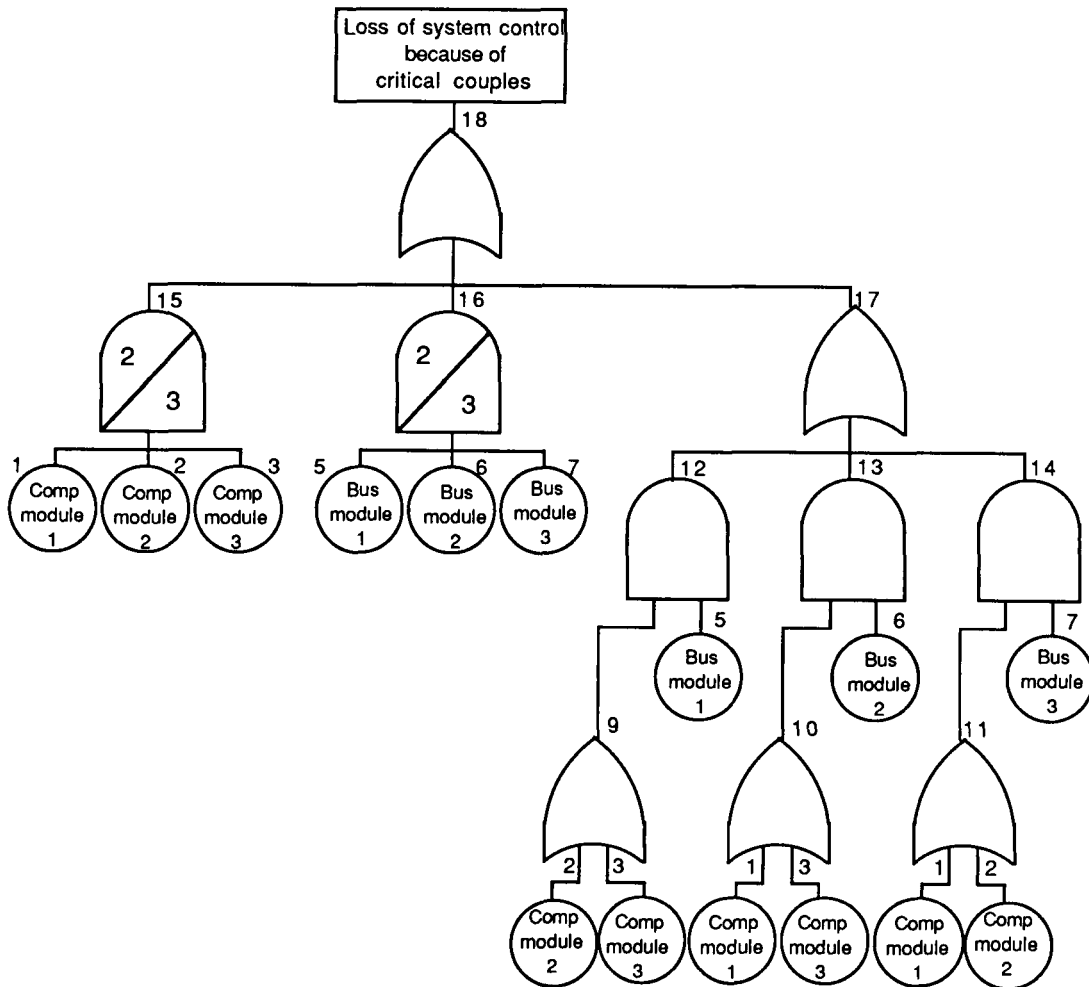

Figure 8.4. Example problem 7 critical pair tree.

8.6. Using the User-Friendly Interface

Use of the user-friendly interface for example problem 7 is outlined in the following section.

Preliminary:

It is recommended that the user understand the critical pair tree used in this example before continuing to the **Critical Pairs Fault Tree Input**.

Stage Description Input

Enter the CARE3MENU program as in the previous examples. The input values are listed below.

Stage name	Beginning modules	Minimum modules	Beginning submodules	Set(s) of modules	Number of FHM's
<u>INERTIAL REF</u>	<u>3</u>	<u>2</u>	<u>0</u>		<u>0</u>
<u>PITCH RATE</u>	<u>3</u>	<u>2</u>	<u>0</u>		<u>0</u>
<u>COMPUTER</u>	<u>4</u>	<u>2</u>	<u>0</u>	<u>3</u>	<u>1</u>
<u>SECONDARY ACT</u>	<u>3</u>	<u>2</u>	<u>0</u>		<u>0</u>
<u>COMPUTER BUS</u>	<u>4</u>	<u>2</u>	<u>0</u>	<u>3</u>	<u>1</u>

Fault Handling Models

Enter the fault types that are used in this problem.

Fault type	Parameter	Value	Distribution
<u>PERMANENT C</u>	Delta =	<u>360</u>	EXPONENTIAL
	Rho =	<u>180</u>	EXPONENTIAL
	Epsilon =	<u>3600</u>	EXPONENTIAL
	C =	<u>.999</u>	
<u>PERMANENT B</u>	Delta =	<u>1.0 E4</u>	EXPONENTIAL
	Rho =	<u>0.0</u>	EXPONENTIAL
	Epsilon =	<u>0.0</u>	EXPONENTIAL
	C =	<u>1.0</u>	EXPONENTIAL

Fault Occurrence Models

For all the fault occurrence models below, select the defaults for the FOM (exponential default) and for omega (default = 1.0). The only values to be input are fault type and lambda.

Stage	Fault type	Lambda
<u>INERTIAL REF</u>	<u>(NONE)</u>	<u>1.5 E-5</u>
<u>PITCH RATE</u>	<u>(NONE)</u>	<u>1.9 E-5</u>
<u>COMPUTER</u>	<u>PERMANENT C</u>	<u>4.8 E-4</u>
<u>SECONDARY ACT</u>	<u>(NONE)</u>	<u>3.7 E-5</u>
<u>COMPUTER BUS</u>	<u>PERMANENT B</u>	<u>2.7 E-6</u>

(Verify the information summary against the system tree and continue to the tree entry.)

System Fault Tree Input

Enter System Tree Label

SYSTEM TREE EX 7 cr

Input Event ID Range: 1 5

Output Gate ID Range: 6 6 cr

Enter System Fault Tree Logic Block

6 0 1 2 3 4 5 cr

Critical Pairs Fault Tree Input

Enter Fault Tree Label

CRITICAL PAIRS TREE EX 7 cr

Enter Module and Logic Range ID

1 8 9 18 cr

(The inputs to the tree are numbered 1 to 8, and the outputs are numbered 9 to 18.)

Enter Module Unit to Stage Association

3 1 4 cr

5 5 8 cr

END cr

(The inputs numbered 1 to 4 are modules from stage 3 (the computer and the stage) inputs numbered 5 to 8 are modules from stage 5, the bus stage.)

Enter Logic Gate ID

9 O 2 3 cr

10 O 1 3 cr

11 O 1 2 cr

12 A 9 5 cr

13 A 10 6 cr

14 A 11 7 cr

15 2 1 2 3 cr

16 2 5 6 7 cr

17 O 12 13 14 cr

18 O 15 16 17 cr

Enter Fault Tree Label

END cr

Output Control Options Input

(Select defaults and verify.)

Runtime Control Options Input

Mission Time: 10 cr

(Select defaults and verify.)

MODEL INPUT COMPLETE

Do you wish to review or alter this model (Y/N)? N cr

(Store the model as EX7.DAT and exit the CARE3MENU program.)

FORTRAN STOP

9. Example Problem 8 Description

Example problem 8 (fig. 9.1) combines a critical pair tree model based on example problem 7 with a system tree that incorporates stage redundancy. Since an analog computer is redundant to

the digital computers, a critical pair failure in the digital computers does not cause system failure. However, since the analog computer uses the computer bus, a critical pair failure in the bus will cause system failure.

This example also includes a full single-fault model (as used before in example problem 5) and adds a critical pair intermittent model. Because an intermittent single-fault model is defined for the computer bus stage and because critically coupled faults in the bus stage cause system failure, the reliability assessment takes into account the effects of latent intermittents that can form critical pairs. Further information is given in the double-fault model and should be studied.

In this problem $C = 1.0$ for all fault handling models, and therefore there are no single-point failures to cause system failure.

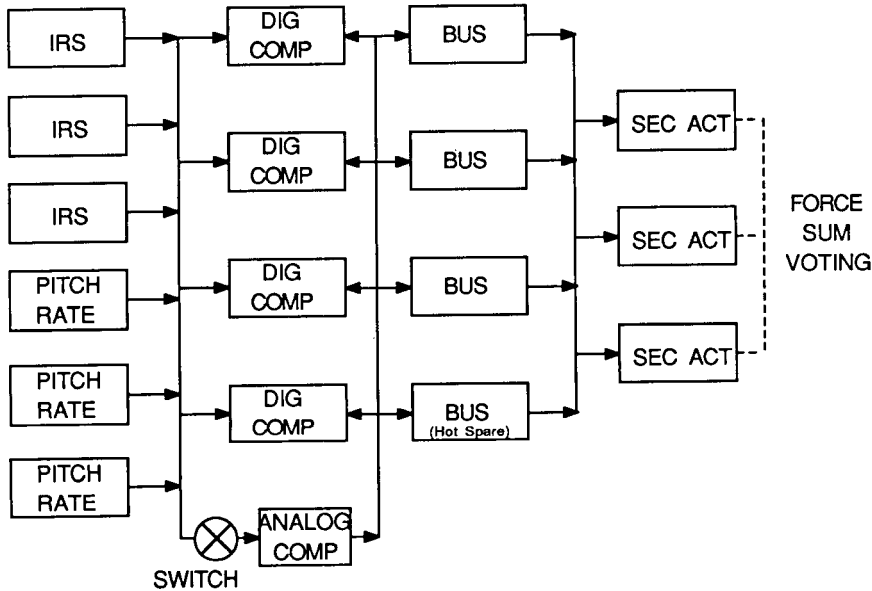

Figure 9.1. Example problem 8 functional block diagram.

9.1. System Failure Criteria

The system failure criteria for example problem 8 are as follows:

1. The system fails if the inertial reference sensor, pitch rate sensor, actuator stage, or bus stage fails, or if the digital computer stage fails and the analog computer or transfer switch fails.
2. The system fails if a critically coupled failure occurs in the bus stage.
3. The inertial reference sensor stage fails if two out of three modules fail. The computer stage fails if three out of four modules fail. The secondary actuator fails if two out of three modules fail. The bus stage fails if two out of three modules fail.

9.2. Input Data

For the Fault Occurrence Model:

Inertial reference sensor modules:	$\lambda = 1.5 \times 10^{-5}$
Pitch rate sensor modules:	$\lambda = 1.9 \times 10^{-5}$
Digital computer modules (permanent):	$\lambda = 4.8 \times 10^{-4}$
Digital computer modules (transient):	$\lambda = 7.2 \times 10^{-3}$
Digital computer modules (intermittent):	$\lambda = 3.3 \times 10^{-4}$
Transfer switch:	$\lambda = 1.7 \times 10^{-10}$
Analog computer module:	$\lambda = 2.3 \times 10^{-9}$
Secondary actuator modules:	$\lambda = 3.7 \times 10^{-5}$
Bus modules (permanent):	$\lambda = 2.7 \times 10^{-6}$
Bus modules (transient):	$\lambda = 6.2 \times 10^{-4}$
Bus modules (intermittent):	$\lambda = 3.7 \times 10^{-5}$

For the Fault Handling Model:

Self-test rate:

Computer stage: $\delta(t') = 360$ detections per hour

Computer bus stage: $\delta(t') = 1.0 \times 10^4$ detections per hour

Error generation rate:

Computer stage: $\rho(t') = 180$ errors per hour

Computer bus stage: $\rho(t') = 0$ errors per hour

Error detection rate:

Computer stage: $\varepsilon(\tau) = 3600$ detections per hour

Computer bus stage: $\varepsilon(\tau) = 0$ detections per hour

Error recovery probability:

Computer stage: $C = 1.0$

Computer bus stage: $C = 1.0$

Transient duration rate α :	3.6×10^4
Intermittent duration rate α :	2.1×10^3
Intermittent benign to active rate β :	3.0×10^3
Retire module (active fault) probability P_A :	1.0
Retire module (benign error) probability P_B :	0

9.3. System Tree

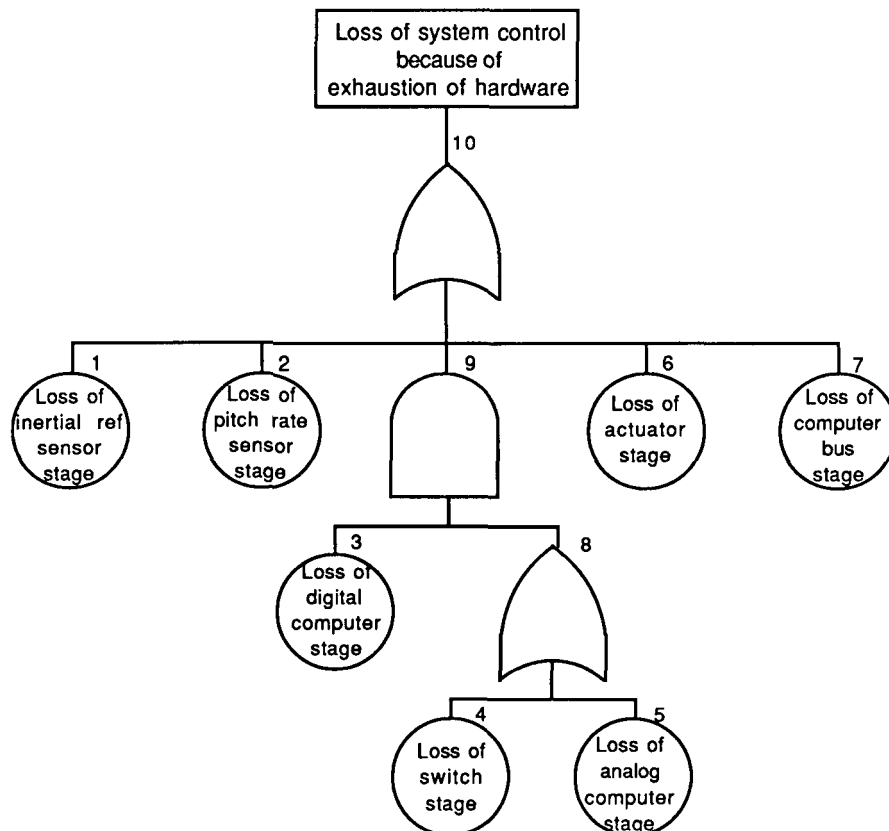

Figure 9.2. Example problem 8 system tree.

9.4. Single-Fault Model

The general single-fault model (fig. 9.3) is intended to represent most system fault handling methods. For example, a system that detects faults only after errors have occurred can be modeled by setting $\delta(t') = 0$ and supplying the appropriate values for the error generation rate $\rho(t')$ and the error detection rate $\epsilon(\tau)$. Note that single-point failures are not modeled unless $C < 1.0$ and $\rho(t') > 0$.

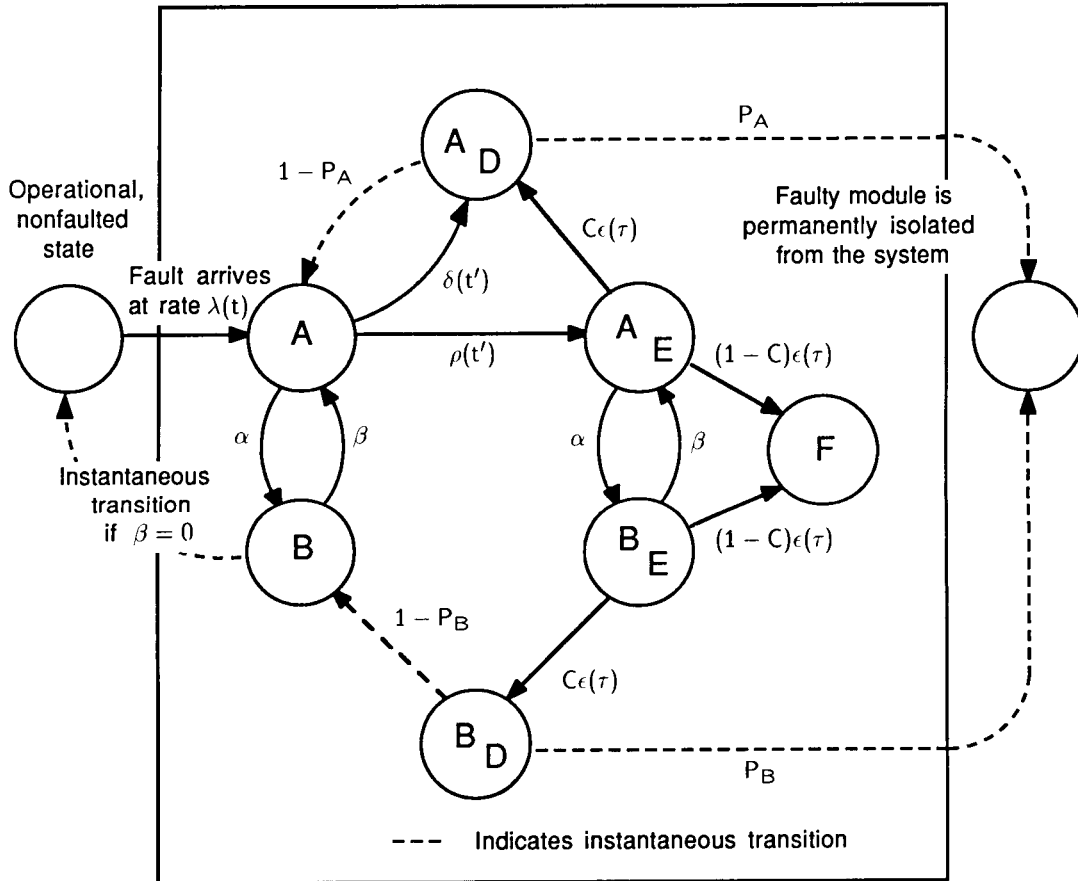

Figure 9.3. Example problem 8 general single-fault model.

9.5. Critical Pair Tree

The critical pair tree (fig. 9.4) does not include a gate for critical pair failures in the computer stage because the analog computer is redundant to the digital computer stage. In other words, the loss of the digital computer stage, for whatever cause, does not cause system failure. The analog computer stage does not contribute a critical pair gate linking the C-bus to the analog computer since the loss of the analog computer after a loss of the digital computer stage causes system failure, irrespective of the bus failure. Only critical pair failures in the bus stage cause system failure.

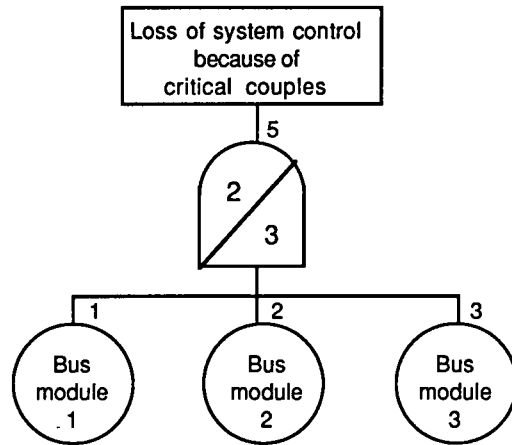

Figure 9.4. Example problem 8 critical pair tree.

9.6. Double Intermittent Fault Model

The double intermittent fault model (fig. 9.5) is invoked whenever critically coupled modules have an intermittent fault model assigned to each module. If an intermittent fault becomes benign (see single-fault model) and another fault occurs that is critically coupled to the benign fault (critical pair tree defines the linking), the double intermittent fault model is entered at state B_1A_2 . Detection of the active fault takes the system to the D (detected) state where the faulty active unit is purged, and once again the system has only one fault—the intermittent benign. If the active fault at state B_1A_2 becomes benign, then state B_1B_2 is entered. From here, either of the two benign faults may become active, leading back to state B_1A_2 or state A_1B_2 . From the B_1A_2/A_1B_2 states, one of the following three transitions may lead to system failure because of critical couplings:

1. The benign fault may become active, leading to the A_1A_2 state.
2. The active fault begins to generate errors.
3. The active fault is detected as nonpermanent with probability $(1 - P_A)$.

Note that the critical pair failure condition occurs only if a critical pair tree is defined and the single-fault model contains an intermittent fault model.

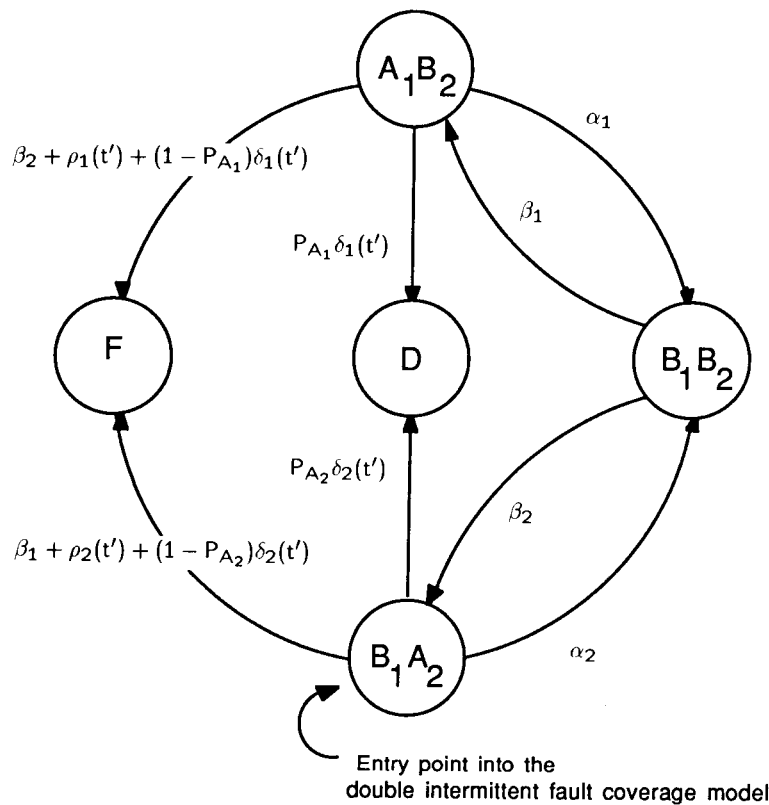

Figure 9.5. Example problem 8 double intermittent fault model.

9.7. Using the User-Friendly Interface

Stage Description Input

Enter the CARE3MENU program as in the previous examples. The input values for the stage description input screens are as follows:

Stage name	Beginning modules	Minimum modules	Beginning submodules	Set(s) of modules	Number of FHM's
<u>INERTIAL REF</u>	<u>3</u>	<u>2</u>	<u>0</u>		<u>0</u>
<u>PITCH RATE</u>	<u>3</u>	<u>2</u>	<u>0</u>		<u>0</u>
<u>DIGITAL COMPUTER</u>	<u>4</u>	<u>2</u>	<u>0</u>		<u>3</u>
<u>SWITCH</u>	<u>1</u>	<u>1</u>	<u>0</u>		<u>0</u>
<u>ANALOG COMPUTER</u>	<u>1</u>	<u>1</u>	<u>0</u>		<u>0</u>
<u>SECONDARY ACT</u>	<u>3</u>	<u>2</u>	<u>0</u>		<u>0</u>
<u>COMPUTER BUS</u>	<u>4</u>	<u>2</u>	<u>0</u>	<u>3</u>	<u>3</u>

Fault Handling Models

Fault type	Parameter	Value	Distribution
<u>PERMANENT C</u>	Delta = Rho = Epsilon = C =	360 180 3600 1.0	EXPONENTIAL EXPONENTIAL EXPONENTIAL
<u>PERMANENT B</u>	Delta = Rho = Epsilon = C =	1.0 E4 0.0 0.0 1.0	EXPONENTIAL EXPONENTIAL EXPONENTIAL
<u>TRANSIENT</u>	Alpha = Delta = Rho = Epsilon = Pa = C =	3.6 E4 360 180 3600 1.0 1.0	(Exponential) EXPONENTIAL EXPONENTIAL EXPONENTIAL
<u>INTERMITTENT</u>	Alpha = Beta = Delta = Rho = Epsilon = Pa = Pb = C =	2.1 E3 3.0 E3 360 180 3600 1.0 0.0 1.0	(Exponential) (Exponential) EXPONENTIAL EXPONENTIAL EXPONENTIAL

Fault Occurrence Models

For all the fault occurrence models below, select the defaults for the FOM (exponential default) and for omega (default = 1.0). The only values to be input are fault type and lambda.

Stage	Fault type	Lambda
INERTIAL REF	(NONE)	1.5 E-5
PITCH RATE	(NONE)	1.9 E-5
DIGITAL COMPUTER	<u>PERMANENT C</u>	4.8 E-4
	<u>TRANSIENT</u>	7.2 E-3
	<u>INTERMITTENT</u>	3.3 E-4
SWITCH	(NONE)	1.7 E-10
ANALOG COMPUTER	(NONE)	2.3 E-9
SECONDARY ACT	(NONE)	3.7 E-5
COMPUTER BUS	<u>PERMANENT B</u>	2.7 E-6
	<u>TRANSIENT</u>	6.2 E-4
	<u>INTERMITTENT</u>	3.7 E-5

(Verify the information summary against the system tree and continue to the tree entry.)

System Fault Tree Input

Enter System Tree Label

SYSTEM TREE EX 8 cr

Input Event ID Range: 1 7

Output Gate ID Range: 8 10 cr

Enter System Fault Tree Logic Block

8 O 4 5 cr

9 A 3 8 cr

10 O 1 2 9 6 7 cr

Critical Pairs Fault Tree Input

Enter Fault Tree Label

CRITICAL PAIRS TREE EX 8 cr

Enter Module and Logic Range ID

1 4 5 5 cr

Enter Module Unit to Stage Association

7 1 4 cr

END cr

(The modules numbered 1 to 4 are those associated with stage 7, which for this problem is the computer bus stage.)

Enter Logic Gate ID

5 2 1 2 3 cr

Enter Fault Tree Label

END cr

Output Control Options Input

(Select defaults and verify.)

Runtime Control Options Input

Mission Time: 10 cr

(Select defaults and verify.)

MODEL INPUT COMPLETE

Do you wish to review or alter this model (Y/N)? N cr

(Store this model as EX8.DAT and exit the CARE3MENU program.)

FORTRAN STOP

10. Concluding Remarks

The user-friendly interface is designed to make system descriptions easier to translate into CARE III input files. The series of examples shown in this demonstration and tutorial are designed to lead the beginning user through a progression of increasingly difficult problems. By example problem 8 the user should feel comfortable with the system.

The authors have assumed that users have a basic understanding of the concepts and terms used in conjunction with CARE III. Such an understanding will greatly increase the ease of using the CARE3MENU program.

NASA Langley Research Center
Hampton, Virginia 23665-5225
August 24, 1987

Appendix A

Output Listings

In the following pages are partial output listings for each of the example problems described in this manual. Only the input file data and unreliability summaries are included.

As CARE III is modified, the visual appearance of the output may change slightly. Also, different computers may yield small differences in the answers. Users are encouraged to look through these listings and note how the system unreliabilities change as the simple problems are expanded to include fault handling.

Example Problem 1A Output

```

$FHMNAMES
  FHMNAME(1)= '(NONE)'
$END
$FLTITYP
  NFTYPS=1,
  ALP=      0.0      ,
  BET=      0.0      ,
  DEL=    3600.0    ,
  RHO=      0.0      ,
  EPS=      0.0      ,
  IDELF=    1        ,
  IRHOF=    1        ,
  IEPSF=    1        ,
  MARKOV=   1        ,
  PA=       1.0      ,
  PB=       1.0      ,
  C=        1.0      ,
  LGTMST=T
$END
$STGNAMES
  STGNAME(1)= 'SENSOR',
  STGNAME(2)= 'COMPUTER',
  STGNAME(3)= 'ACTUATOR'
$END
$STAGES
  NSTGES=3,
  N = 1, 1, 1,
  M = 1, 1, 1,
  NSUB= 0, 0, 0,
  MSUB= 0, 0, 0,
  LC= 0, 0, 0,
  IRLPCD=1,
  RLPLOT=F, IAXSRL=2
$END
$FLTCAT
  NFCATS=1,1,1,
  JTYP(1,1)= 1,
  JTYP(1,2)= 1,
  JTYP(1,3)= 1,
  OMG(1,1)=      1.0      ,
  OMG(1,2)=      1.0      ,
  OMG(1,3)=      1.0      ,
  RLM(1,1)= 1.500000E-05,
  RLM(1,2)= 4.800000E-04,
  RLM(1,3)= 3.700000E-05
$END
$RNTIME
  FT= 10.0000      ,ITBASE=1,
  PSTRNC= 0.100000E-09,
  QPTRNC= 0.100000E-01,
  NPSBRN=20,
  CKDATA=T,
  SYSFLG=T,CPLFLG=F
$END

```

Example Problem 1A Output

SYSTEM TREE EX 1
 1 3 4 4
 4 0 1 2 3

S U M M A R Y I N F O R M A T I O N :

	<u>T I M E</u> (HOURS)	<u>Q S U M</u>	<u>P* S U M</u>	<u>Q S U M +</u> <u>P* S U M</u>
1	0.00000E+00	0.00000E+00	0.00000E+00	0.00000E+00
2	4.90196E-03	0.00000E+00	2.60784E-06	2.60784E-06
3	9.80392E-03	0.00000E+00	5.21567E-06	5.21567E-06
4	1.47059E-02	0.00000E+00	7.82350E-06	7.82350E-06
5	1.96078E-02	0.00000E+00	1.04313E-05	1.04313E-05
6	2.45098E-02	0.00000E+00	1.30391E-05	1.30391E-05
7	2.94118E-02	0.00000E+00	1.56469E-05	1.56469E-05
8	3.43137E-02	0.00000E+00	1.82547E-05	1.82547E-05
9	3.92157E-02	0.00000E+00	2.08625E-05	2.08625E-05
10	4.90196E-02	0.00000E+00	2.60781E-05	2.60781E-05
11	5.88235E-02	0.00000E+00	3.12936E-05	3.12936E-05
12	6.86275E-02	0.00000E+00	3.65091E-05	3.65091E-05
13	7.84314E-02	0.00000E+00	4.17246E-05	4.17246E-05
14	8.82353E-02	0.00000E+00	4.69401E-05	4.69401E-05
15	9.80392E-02	0.00000E+00	5.21555E-05	5.21555E-05
16	1.07843E-01	0.00000E+00	5.73709E-05	5.73709E-05
17	1.17647E-01	0.00000E+00	6.25863E-05	6.25863E-05
18	1.37255E-01	0.00000E+00	7.30169E-05	7.30169E-05
19	1.56863E-01	0.00000E+00	8.34475E-05	8.34475E-05
20	1.76471E-01	0.00000E+00	9.38779E-05	9.38779E-05
21	1.96078E-01	0.00000E+00	1.04308E-04	1.04308E-04
22	2.15686E-01	0.00000E+00	1.14739E-04	1.14739E-04
23	2.35294E-01	0.00000E+00	1.25169E-04	1.25169E-04
24	2.54902E-01	0.00000E+00	1.35599E-04	1.35599E-04
25	2.74510E-01	0.00000E+00	1.46029E-04	1.46029E-04
26	3.13726E-01	0.00000E+00	1.66888E-04	1.66888E-04
27	3.52941E-01	0.00000E+00	1.87747E-04	1.87747E-04
28	3.92157E-01	0.00000E+00	2.08606E-04	2.08606E-04
29	4.31373E-01	0.00000E+00	2.29464E-04	2.29464E-04
30	4.70588E-01	0.00000E+00	2.50322E-04	2.50322E-04
31	5.09804E-01	0.00000E+00	2.71179E-04	2.71179E-04
32	5.49020E-01	0.00000E+00	2.92036E-04	2.92036E-04
33	5.88235E-01	0.00000E+00	3.12892E-04	3.12892E-04
34	6.66667E-01	0.00000E+00	3.54604E-04	3.54604E-04
35	7.45098E-01	0.00000E+00	3.96314E-04	3.96314E-04

Example Problem 1A Output

36	8.23529E-01	0.00000E+00	4.38022E-04	4.38022E-04
37	9.01961E-01	0.00000E+00	4.79728E-04	4.79728E-04
38	9.80392E-01	0.00000E+00	5.21433E-04	5.21433E-04
39	1.05882E+00	0.00000E+00	5.63136E-04	5.63136E-04
40	1.13725E+00	0.00000E+00	6.04837E-04	6.04837E-04
41	1.21569E+00	0.00000E+00	6.46536E-04	6.46536E-04
42	1.37255E+00	0.00000E+00	7.29930E-04	7.29930E-04
43	1.52941E+00	0.00000E+00	8.13316E-04	8.13316E-04
44	1.68627E+00	0.00000E+00	8.96696E-04	8.96696E-04
45	1.84314E+00	0.00000E+00	9.80068E-04	9.80068E-04
46	2.00000E+00	0.00000E+00	1.06343E-03	1.06343E-03
47	2.15686E+00	0.00000E+00	1.14677E-03	1.14677E-03
48	2.31373E+00	0.00000E+00	1.23013E-03	1.23013E-03
49	2.47059E+00	0.00000E+00	1.31349E-03	1.31349E-03
50	2.78431E+00	0.00000E+00	1.48014E-03	1.48014E-03
51	3.09804E+00	0.00000E+00	1.64679E-03	1.64679E-03
52	3.41176E+00	0.00000E+00	1.81343E-03	1.81343E-03
53	3.72549E+00	0.00000E+00	1.98001E-03	1.98001E-03
54	4.03922E+00	0.00000E+00	2.14658E-03	2.14658E-03
55	4.35294E+00	0.00000E+00	2.31309E-03	2.31309E-03
56	4.66667E+00	0.00000E+00	2.47959E-03	2.47959E-03
57	4.98039E+00	0.00000E+00	2.64609E-03	2.64609E-03
58	5.60784E+00	0.00000E+00	2.97895E-03	2.97895E-03
59	6.23529E+00	0.00000E+00	3.31167E-03	3.31167E-03
60	6.86274E+00	0.00000E+00	3.64431E-03	3.64431E-03
61	7.49020E+00	0.00000E+00	3.97687E-03	3.97687E-03
62	8.11765E+00	0.00000E+00	4.30929E-03	4.30929E-03
63	8.74510E+00	0.00000E+00	4.64157E-03	4.64157E-03
64	9.37255E+00	0.00000E+00	4.97377E-03	4.97377E-03
65	1.00000E+01	0.00000E+00	5.30589E-03	5.30589E-03

K AFTER EXACTLY K STAGES HAVE FAILED BY 1.00000E+01
 STAGE HOURS, PORTION OF THE UNRELIABILITY CAUSED BY:
 FAILURES

	FAULT HANDLING	EXHAUSTION OF MODULES
0	0.00000E+00	0.00000E+00
1	0.00000E+00	5.30335E-03
2	0.00000E+00	2.54434E-06
3	0.00000E+00	2.65694E-10

TOTAL SYSTEM UNRELIABILITY AT 1.00000E+01 HOURS = 5.30589E-03

Example Problem 1B Output

```

$FHMNAMES
  FHMNAME(1)= '(NONE)'
$END
$FLITYP
  NFTYPS=1,
  ALP=      0.0      ,
  BET=      0.0      ,
  DEL=    3600.0    ,
  RHO=      0.0      ,
  EPS=      0.0      ,
  IDELF=     1      ,
  IRHOF=     1      ,
  IEPSF=     1      ,
  MARKOV=    1      ,
  PA=       1.0      ,
  PB=       1.0      ,
  C=        1.0      ,
  LGTMST=T
$END
$STGNAMES
  STGNAME(1)= 'SENSOR',
  STGNAME(2)= 'COMPUTER',
  STGNAME(3)= 'ACTUATOR'
$END
$STAGES
  NSTGES=3,
  N = 1, 1, 1,
  M = 1, 1, 1,
  NSUB= 0, 0, 0,
  MSUB= 0, 0, 0,
  LC= 0, 0, 0,
  IRLPCD=1,
  RLPLOT=F, IAXSRL=2
$END
$FLTCAT
  NFCATS=1,1,1,
  JTYP(1,1)= 1,
  JTYP(1,2)= 1,
  JTYP(1,3)= 1,
  OMG(1,1)=      1.1      ,
  OMG(1,2)=      1.0      ,
  OMG(1,3)=      1.1      ,
  RLM(1,1)= 1.500000E-05,
  RLM(1,2)= 4.800000E-04,
  RLM(1,3)= 3.700000E-05
$END
$RNTIME
  FT= 10.0000      ,ITBASE=1,
  PSTRNC= 0.100000E-09,
  QPTRNC= 0.100000E-01,
  NPSBRN=20,
  CKDATA=T,
  SYSFLG=T,CPLFLG=F
$END

```

Example Problem 1B Output

SYSTEM TREE EX 1
 1 3 4 4
 4 0 1 2 3

S U M M A R Y I N F O R M A T I O N :

	<u>T I M E</u> <u>(HOURS)</u>	<u>Q S U M</u>	<u>P* S U M</u>	<u>Q S U M +</u> <u>P* S U M</u>
1	0.00000E+00	0.00000E+00	0.00000E+00	0.00000E+00
2	4.90196E-03	0.00000E+00	2.40557E-06	2.40557E-06
3	9.80392E-03	0.00000E+00	4.81870E-06	4.81870E-06
4	1.47059E-02	0.00000E+00	7.23504E-06	7.23504E-06
5	1.96078E-02	0.00000E+00	9.65357E-06	9.65357E-06
6	2.45098E-02	0.00000E+00	1.20738E-05	1.20738E-05
7	2.94118E-02	0.00000E+00	1.44953E-05	1.44953E-05
8	3.43137E-02	0.00000E+00	1.69180E-05	1.69180E-05
9	3.92157E-02	0.00000E+00	1.93418E-05	1.93418E-05
10	4.90196E-02	0.00000E+00	2.41918E-05	2.41918E-05
11	5.88235E-02	0.00000E+00	2.90447E-05	2.90447E-05
12	6.86275E-02	0.00000E+00	3.39000E-05	3.39000E-05
13	7.84314E-02	0.00000E+00	3.87576E-05	3.87576E-05
14	8.82353E-02	0.00000E+00	4.36170E-05	4.36170E-05
15	9.80392E-02	0.00000E+00	4.84781E-05	4.84781E-05
16	1.07843E-01	0.00000E+00	5.33407E-05	5.33407E-05
17	1.17647E-01	0.00000E+00	5.82047E-05	5.82047E-05
18	1.37255E-01	0.00000E+00	6.79367E-05	6.79367E-05
19	1.56863E-01	0.00000E+00	7.76731E-05	7.76731E-05
20	1.76471E-01	0.00000E+00	8.74136E-05	8.74136E-05
21	1.96078E-01	0.00000E+00	9.71576E-05	9.71576E-05
22	2.15686E-01	0.00000E+00	1.06905E-04	1.06905E-04
23	2.35294E-01	0.00000E+00	1.16655E-04	1.16655E-04
24	2.54902E-01	0.00000E+00	1.26408E-04	1.26408E-04
25	2.74510E-01	0.00000E+00	1.36164E-04	1.36164E-04
26	3.13726E-01	0.00000E+00	1.55682E-04	1.55682E-04
27	3.52941E-01	0.00000E+00	1.75209E-04	1.75209E-04
28	3.92157E-01	0.00000E+00	1.94743E-04	1.94743E-04
29	4.31373E-01	0.00000E+00	2.14284E-04	2.14284E-04
30	4.70588E-01	0.00000E+00	2.33831E-04	2.33831E-04
31	5.09804E-01	0.00000E+00	2.53384E-04	2.53384E-04
32	5.49020E-01	0.00000E+00	2.72942E-04	2.72942E-04
33	5.88235E-01	0.00000E+00	2.92505E-04	2.92505E-04
34	6.66667E-01	0.00000E+00	3.31645E-04	3.31645E-04
35	7.45098E-01	0.00000E+00	3.70801E-04	3.70801E-04

Example Problem 1B Output

36	8.23529E-01	0.00000E+00	4.09971E-04	4.09971E-04
37	9.01961E-01	0.00000E+00	4.49155E-04	4.49155E-04
38	9.80392E-01	0.00000E+00	4.88351E-04	4.88351E-04
39	1.05882E+00	0.00000E+00	5.27558E-04	5.27558E-04
40	1.13725E+00	0.00000E+00	5.66775E-04	5.66775E-04
41	1.21569E+00	0.00000E+00	6.06001E-04	6.06001E-04
42	1.37255E+00	0.00000E+00	6.84480E-04	6.84480E-04
43	1.52941E+00	0.00000E+00	7.62991E-04	7.62991E-04
44	1.68627E+00	0.00000E+00	8.41528E-04	8.41528E-04
45	1.84314E+00	0.00000E+00	9.20091E-04	9.20091E-04
46	2.00000E+00	0.00000E+00	9.98676E-04	9.98676E-04
47	2.15686E+00	0.00000E+00	1.07726E-03	1.07726E-03
48	2.31373E+00	0.00000E+00	1.15589E-03	1.15589E-03
49	2.47059E+00	0.00000E+00	1.23454E-03	1.23454E-03
50	2.78431E+00	0.00000E+00	1.39186E-03	1.39186E-03
51	3.09804E+00	0.00000E+00	1.54924E-03	1.54924E-03
52	3.41176E+00	0.00000E+00	1.70670E-03	1.70670E-03
53	3.72549E+00	0.00000E+00	1.86416E-03	1.86416E-03
54	4.03922E+00	0.00000E+00	2.02168E-03	2.02168E-03
55	4.35294E+00	0.00000E+00	2.17920E-03	2.17920E-03
56	4.66667E+00	0.00000E+00	2.33676E-03	2.33676E-03
57	4.98039E+00	0.00000E+00	2.49437E-03	2.49437E-03
58	5.60784E+00	0.00000E+00	2.80961E-03	2.80961E-03
59	6.23529E+00	0.00000E+00	3.12488E-03	3.12488E-03
60	6.86274E+00	0.00000E+00	3.44024E-03	3.44024E-03
61	7.49020E+00	0.00000E+00	3.75566E-03	3.75566E-03
62	8.11765E+00	0.00000E+00	4.07109E-03	4.07109E-03
63	8.74510E+00	0.00000E+00	4.38651E-03	4.38651E-03
64	9.37255E+00	0.00000E+00	4.70197E-03	4.70197E-03
65	1.00000E+01	0.00000E+00	5.01747E-03	5.01747E-03

K STAGE FAILURES	AFTER EXACTLY K STAGES HAVE FAILED BY 1.00000E+01 HOURS, PORTION OF THE UNRELIABILITY CAUSED BY:	
	FAULT HANDLING	EXHAUSTION OF MODULES
0	0.00000E+00	0.00000E+00
1	0.00000E+00	5.01635E-03
2	0.00000E+00	1.11194E-06
3	0.00000E+00	4.99889E-11

TOTAL SYSTEM UNRELIABILITY AT 1.00000E+01 HOURS = 5.01747E-03

Example Problem 2A Output

```

$FHMNAMES
  FHMNAME(1)= '(NONE)'
$END
$FLTTYF
  NFTYPS=1,
  ALP=      0.0  ,
  BET=      0.0  ,
  DEL=    3600.0 ,
  RHO=      0.0  ,
  EPS=      0.0  ,
  IDELF=     1   ,
  IRHOF=     1   ,
  IEPSF=     1   ,
  MARKOV=    1   ,
  PA=       1.0  ,
  PB=       1.0  ,
  C=        1.0  ,
  LGTMST=T
$END
$STGNAMES
  STGNAME(1)= 'INERTIAL REF',
  STGNAME(2)= 'PITCH RATE',
  STGNAME(3)= 'COMPUTER',
  STGNAME(4)= 'SECONDARY ACT'
$END
$STAGES
  NSTGES=4,
  N = 3, 3, 4, 3,
  M = 2, 2, 2, 2,
  NSUB= 0, 0, 0, 0,
  MSUB= 0, 0, 0, 0,
  LC= 0, 0, 0, 0,
  IRLPCD=1,
  RLPLOT=F, IAXSRL=2
$END
$FLTCAT
  NFCATS=1,1,1,1,
  JTYP(1,1)= 1,
  JTYP(1,2)= 1,
  JTYP(1,3)= 1,
  JTYP(1,4)= 1,
  OMG(1,1)= 1.0  ,
  OMG(1,2)= 1.0  ,
  OMG(1,3)= 1.0  ,
  OMG(1,4)= 1.0  ,
  RLM(1,1)= 1.500000E-05,
  RLM(1,2)= 1.900000E-05,
  RLM(1,3)= 4.800000E-04,
  RLM(1,4)= 3.700000E-05
$END
$RNTIME
  FT= 10.0000  ,ITBASE=1,
  PSTRNC= 0.100000E-09,
  QPTRNC= 0.100000E-01,
  NPSBRN=20,

```

Example Problem 2A Output

CKDATA=T,
 SYSFLG=T,CPLFLG=F
 \$END
 SYSTEM TREE EXS 2
 1 4 5 5
 5 0 1 2 3 4

S U M M A R Y I N F O R M A T I O N :

	<u>T I M E</u> (HOURS)	<u>Q S U M</u>	<u>P* S U M</u>	<u>Q S U M +</u> <u>P* S U M</u>
1	0.00000E+00	0.00000E+00	0.00000E+00	0.00000E+00
2	4.90196E-03	0.00000E+00	1.40983E-13	1.40983E-13
3	9.80392E-03	0.00000E+00	5.64142E-13	5.64142E-13
4	1.47059E-02	0.00000E+00	1.26979E-12	1.26979E-12
5	1.96078E-02	0.00000E+00	2.25824E-12	2.25824E-12
6	2.45098E-02	0.00000E+00	3.52979E-12	3.52979E-12
7	2.94118E-02	0.00000E+00	5.08478E-12	5.08478E-12
8	3.43137E-02	0.00000E+00	6.92350E-12	6.92350E-12
9	3.92157E-02	0.00000E+00	9.04627E-12	9.04627E-12
10	4.90196E-02	0.00000E+00	1.41452E-11	1.41452E-11
11	5.88235E-02	0.00000E+00	2.03841E-11	2.03841E-11
12	6.86275E-02	0.00000E+00	2.77654E-11	2.77654E-11
13	7.84314E-02	0.00000E+00	3.62917E-11	3.62917E-11
14	8.82353E-02	0.00000E+00	4.59654E-11	4.59654E-11
15	9.80392E-02	0.00000E+00	5.67891E-11	5.67891E-11
16	1.07843E-01	0.00000E+00	6.87652E-11	6.87652E-11
17	1.17647E-01	0.00000E+00	8.18962E-11	8.18962E-11
18	1.37255E-01	0.00000E+00	1.11633E-10	1.11633E-10
19	1.56863E-01	0.00000E+00	1.46020E-10	1.46020E-10
20	1.76471E-01	0.00000E+00	1.85076E-10	1.85076E-10
21	1.96078E-01	0.00000E+00	2.28822E-10	2.28822E-10
22	2.15686E-01	0.00000E+00	2.77278E-10	2.77278E-10
23	2.35294E-01	0.00000E+00	3.30463E-10	3.30463E-10
24	2.54902E-01	0.00000E+00	3.88398E-10	3.88398E-10
25	2.74510E-01	0.00000E+00	4.51103E-10	4.51103E-10
26	3.13726E-01	0.00000E+00	5.90900E-10	5.90900E-10
27	3.52941E-01	0.00000E+00	7.50016E-10	7.50016E-10
28	3.92157E-01	0.00000E+00	9.28610E-10	9.28610E-10
29	4.31373E-01	0.00000E+00	1.12684E-09	1.12684E-09
30	4.70588E-01	0.00000E+00	1.34487E-09	1.34487E-09
31	5.09804E-01	0.00000E+00	1.58285E-09	1.58285E-09
32	5.49020E-01	0.00000E+00	1.84096E-09	1.84096E-09

Example Problem 2A Output

33	5.88235E-01	0.00000E+00	2.11933E-09	2.11933E-09
34	6.66667E-01	0.00000E+00	2.73755E-09	2.73755E-09
35	7.45098E-01	0.00000E+00	3.43879E-09	3.43879E-09
36	8.23529E-01	0.00000E+00	4.22433E-09	4.22433E-09
37	9.01961E-01	0.00000E+00	5.09543E-09	5.09543E-09
38	9.80392E-01	0.00000E+00	6.05338E-09	6.05338E-09
39	1.05882E+00	0.00000E+00	7.09945E-09	7.09945E-09
40	1.13725E+00	0.00000E+00	8.23491E-09	8.23491E-09
41	1.21569E+00	0.00000E+00	9.46104E-09	9.46104E-09
42	1.37255E+00	0.00000E+00	1.21904E-08	1.21904E-08
43	1.52941E+00	0.00000E+00	1.52977E-08	1.52977E-08
44	1.68627E+00	0.00000E+00	1.87931E-08	1.87931E-08
45	1.84314E+00	0.00000E+00	2.26868E-08	2.26868E-08
46	2.00000E+00	0.00000E+00	2.69889E-08	2.69889E-08
47	2.15686E+00	0.00000E+00	3.17093E-08	3.17093E-08
48	2.31373E+00	0.00000E+00	3.68588E-08	3.68588E-08
49	2.47059E+00	0.00000E+00	4.24474E-08	4.24474E-08
50	2.78431E+00	0.00000E+00	5.49808E-08	5.49808E-08
51	3.09804E+00	0.00000E+00	6.93917E-08	6.93917E-08
52	3.41176E+00	0.00000E+00	8.57613E-08	8.57613E-08
53	3.72549E+00	0.00000E+00	1.04168E-07	1.04168E-07
54	4.03922E+00	0.00000E+00	1.24696E-07	1.24696E-07
55	4.35294E+00	0.00000E+00	1.47421E-07	1.47421E-07
56	4.66667E+00	0.00000E+00	1.72428E-07	1.72428E-07
57	4.98039E+00	0.00000E+00	1.99797E-07	1.99797E-07
58	5.60784E+00	0.00000E+00	2.61933E-07	2.61933E-07
59	6.23529E+00	0.00000E+00	3.34470E-07	3.34470E-07
60	6.86274E+00	0.00000E+00	4.18051E-07	4.18051E-07
61	7.49020E+00	0.00000E+00	5.13315E-07	5.13315E-07
62	8.11765E+00	0.00000E+00	6.20889E-07	6.20889E-07
63	8.74510E+00	0.00000E+00	7.41404E-07	7.41404E-07
64	9.37255E+00	0.00000E+00	8.75503E-07	8.75503E-07
65	1.00000E+01	0.00000E+00	1.02382E-06	1.02382E-06

K STAGE FAILURES	AFTER EXACTLY K STAGES HAVE FAILED BY 1.00000E+01 HOURS, PORTION OF THE UNRELIABILITY CAUSED BY:	
	FAULT HANDLING	EXHAUSTION OF MODULES
0	0.00000E+00	0.00000E+00
1	0.00000E+00	1.02382E-06
2	0.00000E+00	3.35975E-13
3	0.00000E+00	1.94468E-20

TOTAL SYSTEM UNRELIABILITY AT 1.00000E+01 HOURS = 1.02382E-06

Example Problem 2B Output

```

$FHMNAMES
  FHMNAME(1)= '(NONE)'
$END
$FLITYP
  NFTYPS=1,
  ALP=      0.0 ,
  BET=      0.0 ,
  DEL= 3600.0 ,
  RHO=      0.0 ,
  EPS=      0.0 ,
  IDELF=    1 ,
  IRHOF=    1 ,
  IEPSF=    1 ,
  MARKOV=   1 ,
  PA=       1.0 ,
  PB=       1.0 ,
  C=        1.0 ,
  LGTMST=T
$END
$STGNAMES
  STGNAME(1)= 'INERTIAL REF',
  STGNAME(2)= 'PITCH RATE',
  STGNAME(3)= 'COMPUTER',
  STGNAME(4)= 'SECONDARY ACT'
$END
$STAGES
  NSTGES=4,
  N = 3, 3, 4, 3,
  M = 2, 2, 2, 2,
  NSUB= 0, 0, 44, 0,
  MSUB= 0, 0, 40, 0,
  ACSP(3)=T ,
  LC= 0, 0, 0, 0,
  IRLPCD=1,
  RLPLT=F, IAXSRL=2
$END
$FLTCAT
  NFCATS=1,1,1,1,
  JTYP(1,1)= 1,
  JTYP(1,2)= 1,
  JTYP(1,3)= 1,
  JTYP(1,4)= 1,
  OMG(1,1)=   1.0 ,
  OMG(1,2)=   1.0 ,
  OMG(1,3)=   1.0 ,
  OMG(1,4)=   1.0 ,
  RLM(1,1)= 1.500000E-05,
  RLM(1,2)= 1.900000E-05,
  RLM(1,3)= 2.400000E-04,
  RLM(1,4)= 3.700000E-05,
  JSBTYP(1,3)= 1,
  OMGSUB(1,3)=   1.0 ,
  RLMSUB(1,3)= 5.000000E-06,
$END

```

Example Problem 2B Output

\$RNTIME

FT= 10.0000 ,ITBASE=1,
PSTRNC= 0.100000E-09,
QPTRNC= 0.100000E-01,
NPSBRN=20,
CKDATA=T,
SYSFLG=T,CPLFLG=F

\$END

SYSTEM TREE EXS 2

1 4 5 5

5 0 1 2 3 4

S U M M A R Y I N F O R M A T I O N :

	<u>T I M E</u> (HOURS)	<u>Q S U M</u>	<u>P* S U M</u>	<u>Q S U M +</u> <u>P* S U M</u>
1	0.00000E+00	0.00000E+00	0.00000E+00	0.00000E+00
2	4.90196E-03	0.00000E+00	1.40938E-13	1.40938E-13
3	9.80392E-03	0.00000E+00	5.63777E-13	5.63777E-13
4	1.47059E-02	0.00000E+00	1.26856E-12	1.26856E-12
5	1.96078E-02	0.00000E+00	2.25532E-12	2.25532E-12
6	2.45098E-02	0.00000E+00	3.52409E-12	3.52409E-12
7	2.94118E-02	0.00000E+00	5.07493E-12	5.07493E-12
8	3.43137E-02	0.00000E+00	6.90786E-12	6.90786E-12
9	3.92157E-02	0.00000E+00	9.02293E-12	9.02293E-12
10	4.90196E-02	0.00000E+00	1.40996E-11	1.40996E-11
11	5.88235E-02	0.00000E+00	2.03053E-11	2.03053E-11
12	6.86275E-02	0.00000E+00	2.76403E-11	2.76403E-11
13	7.84314E-02	0.00000E+00	3.61050E-11	3.61050E-11
14	8.82353E-02	0.00000E+00	4.56995E-11	4.56995E-11
15	9.80392E-02	0.00000E+00	5.64244E-11	5.64244E-11
16	1.07843E-01	0.00000E+00	6.82797E-11	6.82797E-11
17	1.17647E-01	0.00000E+00	8.12660E-11	8.12660E-11
18	1.37255E-01	0.00000E+00	1.10632E-10	1.10632E-10
19	1.56863E-01	0.00000E+00	1.44526E-10	1.44526E-10
20	1.76471E-01	0.00000E+00	1.82949E-10	1.82949E-10
21	1.96078E-01	0.00000E+00	2.25905E-10	2.25905E-10
22	2.15686E-01	0.00000E+00	2.73395E-10	2.73395E-10
23	2.35294E-01	0.00000E+00	3.25422E-10	3.25422E-10
24	2.54902E-01	0.00000E+00	3.81989E-10	3.81989E-10
25	2.74510E-01	0.00000E+00	4.43098E-10	4.43098E-10
26	3.13726E-01	0.00000E+00	5.78953E-10	5.78953E-10
27	3.52941E-01	0.00000E+00	7.33006E-10	7.33006E-10
28	3.92157E-01	0.00000E+00	9.05277E-10	9.05277E-10

Example Problem 2B Output

29	4.31373E-01	0.00000E+00	1.09579E-09	1.09579E-09
30	4.70588E-01	0.00000E+00	1.30455E-09	1.30455E-09
31	5.09804E-01	0.00000E+00	1.53160E-09	1.53160E-09
32	5.49020E-01	0.00000E+00	1.77694E-09	1.77694E-09
33	5.88235E-01	0.00000E+00	2.04060E-09	2.04060E-09
34	6.66667E-01	0.00000E+00	2.62295E-09	2.62295E-09
35	7.45098E-01	0.00000E+00	3.27882E-09	3.27882E-09
36	8.23529E-01	0.00000E+00	4.00835E-09	4.00835E-09
37	9.01961E-01	0.00000E+00	4.81170E-09	4.81170E-09
38	9.80392E-01	0.00000E+00	5.68905E-09	5.68905E-09
39	1.05882E+00	0.00000E+00	6.64054E-09	6.64054E-09
40	1.13725E+00	0.00000E+00	7.66633E-09	7.66633E-09
41	1.21569E+00	0.00000E+00	8.76658E-09	8.76658E-09
42	1.37255E+00	0.00000E+00	1.11911E-08	1.11911E-08
43	1.52941E+00	0.00000E+00	1.39154E-08	1.39154E-08
44	1.68627E+00	0.00000E+00	1.69407E-08	1.69407E-08
45	1.84314E+00	0.00000E+00	2.02683E-08	2.02683E-08
46	2.00000E+00	0.00000E+00	2.38995E-08	2.38995E-08
47	2.15686E+00	0.00000E+00	2.78354E-08	2.78354E-08
48	2.31373E+00	0.00000E+00	3.20775E-08	3.20775E-08
49	2.47059E+00	0.00000E+00	3.66270E-08	3.66270E-08
50	2.78431E+00	0.00000E+00	4.66531E-08	4.66531E-08
51	3.09804E+00	0.00000E+00	5.79238E-08	5.79238E-08
52	3.41176E+00	0.00000E+00	7.04493E-08	7.04493E-08
53	3.72549E+00	0.00000E+00	8.42397E-08	8.42397E-08
54	4.03922E+00	0.00000E+00	9.93051E-08	9.93051E-08
55	4.35294E+00	0.00000E+00	1.15656E-07	1.15656E-07
56	4.66667E+00	0.00000E+00	1.33302E-07	1.33302E-07
57	4.98039E+00	0.00000E+00	1.52254E-07	1.52254E-07
58	5.60784E+00	0.00000E+00	1.94114E-07	1.94114E-07
59	6.23529E+00	0.00000E+00	2.41316E-07	2.41316E-07
60	6.86274E+00	0.00000E+00	2.93937E-07	2.93937E-07
61	7.49020E+00	0.00000E+00	3.52063E-07	3.52063E-07
62	8.11765E+00	0.00000E+00	4.15776E-07	4.15776E-07
63	8.74510E+00	0.00000E+00	4.85138E-07	4.85138E-07
64	9.37255E+00	0.00000E+00	5.60257E-07	5.60257E-07
65	1.00000E+01	0.00000E+00	6.41198E-07	6.41198E-07

K AFTER EXACTLY K STAGES HAVE FAILED BY 1.00000E+01
 STAGE HOURS, PORTION OF THE UNRELIABILITY CAUSED BY:
 FAILURES

	FAULT HANDLING	EXHAUSTION OF MODULES
0	0.00000E+00	0.00000E+00
1	0.00000E+00	6.41198E-07
2	0.00000E+00	4.44373E-14

TOTAL SYSTEM UNRELIABILITY AT 1.00000E+01 HOURS = 6.41198E-07

Example Problem 3 Output

```

$FHMNAMES
  FHMNAME(1)= '(NONE)'
$END
$FLTTYP
  NFTYPS=1,
  ALP=      0.0 ,
  BET=      0.0 ,
  DEL= 3600.0 ,
  RHO=      0.0 ,
  EPS=      0.0 ,
  IDELF=    1 ,
  IRHOF=    1 ,
  IEPSF=    1 ,
  MARKOV=   1 ,
  PA=       1.0 ,
  PB=       1.0 ,
  C=        1.0 ,
  LGTMST=T
$END
$STGNAMES
  STGNAME(1)= 'COMPUTER A',
  STGNAME(2)= 'COMPUTER B',
  STGNAME(3)= 'COMPUTER C',
  STGNAME(4)= 'COMPUTER D',
  STGNAME(5)= 'INERTIAL SENSOR A',
  STGNAME(6)= 'INERTIAL SENSOR B',
  STGNAME(7)= 'INERTIAL SENSOR C',
  STGNAME(8)= 'PITCH RATE',
  STGNAME(9)= 'ACT ELECTRONICS A',
  STGNAME(10)= 'ACT ELECTRONICS B',
  STGNAME(11)= 'ACT ELECTRONICS C'
$END
$STAGES
  NSTGES=11,
  N = 1, 1, 1, 1, 1, 1, 1, 1, 1, 1, 1,
  M = 1, 1, 1, 1, 1, 1, 1, 1, 1, 1, 1,
  NSUB= 0, 0, 0, 0, 0, 0, 0, 0, 0, 0, 0,
  MSUB= 0, 0, 0, 0, 0, 0, 0, 0, 0, 0, 0,
  LC= 0, 0, 0, 0, 0, 0, 0, 0, 0, 0, 0,
  IRLPCD=1,
  RLPLT=F, IAXSRL=2
$END
$FLTCAT
  NFCATS=1,1,1,1,1,1,1,1,1,1,1,
  JTYP(1,1)= 1,
  JTYP(1,2)= 1,
  JTYP(1,3)= 1,
  JTYP(1,4)= 1,
  JTYP(1,5)= 1,
  JTYP(1,6)= 1,
  JTYP(1,7)= 1,
  JTYP(1,8)= 1,
  JTYP(1,9)= 1,
  JTYP(1,10)= 1,
  JTYP(1,11)= 1,

```

Example Problem 3 Output

```
OMG(1,1)= 1.0 ,
OMG(1,2)= 1.0 ,
OMG(1,3)= 1.0 ,
OMG(1,4)= 1.0 ,
OMG(1,5)= 1.0 ,
OMG(1,6)= 1.0 ,
OMG(1,7)= 1.0 ,
OMG(1,8)= 1.0 ,
OMG(1,9)= 1.0 ,
OMG(1,10)= 1.0 ,
OMG(1,11)= 1.0 ,
RLM(1,1)= 4.400000E-04,
RLM(1,2)= 4.800000E-04,
RLM(1,3)= 3.500000E-04,
RLM(1,4)= 3.100000E-04,
RLM(1,5)= 1.700000E-05,
RLM(1,6)= 1.500000E-05,
RLM(1,7)= 2.100000E-05,
RLM(1,8)= 1.800000E-05,
RLM(1,9)= 3.600000E-05,
RLM(1,10)= 3.100000E-05,
RLM(1,11)= 3.700000E-05
```

\$END

\$RNTIME

```
FT= 10.0000 ,ITBASE=1,
PSTRNC= 0.100000E-09,
QPTRNC= 0.100000E-01,
NPSBRN=20,
CKDATA=T,
SYSFLG=T,CPLFLG=F
```

\$END

SYSTEM TREE EX 3

```
1 11 12 24
12 0 1 5
13 0 2 6
14 0 3 7
15 0 4 8
16 3 12 13 14 15
17 3 1 2 3 4
18 0 1 9
19 0 2 10
20 0 3 11
21 3 1 2 3 4
22 0 16 17
23 3 18 19 20 21
24 0 22 23
```

Example Problem 3 Output

S U M M A R Y I N F O R M A T I O N :

	<u>T I M E</u> <u>(HOURS)</u>	<u>Q S U M</u>	<u>P* S U M</u>	<u>Q S U M +</u> <u>P* S U M</u>
1	0.00000E+00	0.00000E+00	0.00000E+00	0.00000E+00
2	4.90196E-03	0.00000E+00	3.46518E-17	3.46518E-17
3	9.80392E-03	0.00000E+00	2.77213E-16	2.77213E-16
4	1.47059E-02	0.00000E+00	9.35590E-16	9.35590E-16
5	1.96078E-02	0.00000E+00	2.21768E-15	2.21768E-15
6	2.45098E-02	0.00000E+00	4.33139E-15	4.33139E-15
7	2.94118E-02	0.00000E+00	7.48461E-15	7.48461E-15
8	3.43137E-02	0.00000E+00	1.18852E-14	1.18852E-14
9	3.92157E-02	0.00000E+00	1.77411E-14	1.77411E-14
10	4.90196E-02	0.00000E+00	3.46503E-14	3.46503E-14
11	5.88235E-02	0.00000E+00	5.98752E-14	5.98752E-14
12	6.86275E-02	0.00000E+00	9.50788E-14	9.50788E-14
13	7.84314E-02	0.00000E+00	1.41924E-13	1.41924E-13
14	8.82353E-02	0.00000E+00	2.02073E-13	2.02073E-13
15	9.80392E-02	0.00000E+00	2.77190E-13	2.77190E-13
16	1.07843E-01	0.00000E+00	3.68936E-13	3.68936E-13
17	1.17647E-01	0.00000E+00	4.78975E-13	4.78975E-13
18	1.37255E-01	0.00000E+00	7.60581E-13	7.60581E-13
19	1.56863E-01	0.00000E+00	1.13531E-12	1.13531E-12
20	1.76471E-01	0.00000E+00	1.61645E-12	1.61645E-12
21	1.96078E-01	0.00000E+00	2.21731E-12	2.21731E-12
22	2.15686E-01	0.00000E+00	2.95119E-12	2.95119E-12
23	2.35294E-01	0.00000E+00	3.83138E-12	3.83138E-12
24	2.54902E-01	0.00000E+00	4.87117E-12	4.87117E-12
25	2.74510E-01	0.00000E+00	6.08386E-12	6.08386E-12
26	3.13726E-01	0.00000E+00	9.08112E-12	9.08112E-12
27	3.52941E-01	0.00000E+00	1.29295E-11	1.29295E-11
28	3.92157E-01	0.00000E+00	1.77352E-11	1.77352E-11
29	4.31373E-01	0.00000E+00	2.36047E-11	2.36047E-11
30	4.70588E-01	0.00000E+00	3.06442E-11	3.06442E-11
31	5.09804E-01	0.00000E+00	3.89600E-11	3.89600E-11
32	5.49020E-01	0.00000E+00	4.86582E-11	4.86582E-11
33	5.88235E-01	0.00000E+00	5.98453E-11	5.98453E-11
34	6.66667E-01	0.00000E+00	8.71106E-11	8.71106E-11
35	7.45098E-01	0.00000E+00	1.21605E-10	1.21605E-10
36	8.23529E-01	0.00000E+00	1.64179E-10	1.64179E-10
37	9.01961E-01	0.00000E+00	2.15681E-10	2.15681E-10
38	9.80392E-01	0.00000E+00	2.76959E-10	2.76959E-10
39	1.05882E+00	0.00000E+00	3.48863E-10	3.48863E-10
40	1.13725E+00	0.00000E+00	4.32240E-10	4.32240E-10

Example Problem 3 Output

41	1.21569E+00	0.00000E+00	5.27939E-10	5.27939E-10
42	1.37255E+00	0.00000E+00	7.59694E-10	7.59694E-10
43	1.52941E+00	0.00000E+00	1.05091E-09	1.05091E-09
44	1.68627E+00	0.00000E+00	1.40835E-09	1.40835E-09
45	1.84314E+00	0.00000E+00	1.83880E-09	1.83880E-09
46	2.00000E+00	0.00000E+00	2.34902E-09	2.34902E-09
47	2.15686E+00	0.00000E+00	2.94574E-09	2.94574E-09
48	2.31373E+00	0.00000E+00	3.63578E-09	3.63578E-09
49	2.47059E+00	0.00000E+00	4.42596E-09	4.42596E-09
50	2.78431E+00	0.00000E+00	6.33322E-09	6.33322E-09
51	3.09804E+00	0.00000E+00	8.72181E-09	8.72181E-09
52	3.41176E+00	0.00000E+00	1.16457E-08	1.16457E-08
53	3.72549E+00	0.00000E+00	1.51581E-08	1.51581E-08
54	4.03922E+00	0.00000E+00	1.93138E-08	1.93138E-08
55	4.35294E+00	0.00000E+00	2.41649E-08	2.41649E-08
56	4.66667E+00	0.00000E+00	2.97658E-08	2.97658E-08
57	4.98039E+00	0.00000E+00	3.61726E-08	3.61726E-08
58	5.60784E+00	0.00000E+00	5.16073E-08	5.16073E-08
59	6.23529E+00	0.00000E+00	7.08979E-08	7.08979E-08
60	6.86274E+00	0.00000E+00	9.44708E-08	9.44708E-08
61	7.49020E+00	0.00000E+00	1.22751E-07	1.22751E-07
62	8.11765E+00	0.00000E+00	1.56162E-07	1.56162E-07
63	8.74510E+00	0.00000E+00	1.95130E-07	1.95130E-07
64	9.37255E+00	0.00000E+00	2.40074E-07	2.40074E-07
65	1.00000E+01	0.00000E+00	2.91423E-07	2.91423E-07

K AFTER EXACTLY K STAGES HAVE FAILED BY 1.00000E+01
 STAGE HOURS, PORTION OF THE UNRELIABILITY CAUSED BY:
 FAILURES

	FAULT HANDLING	EXHAUSTION OF MODULES
	-----	-----
0	0.00000E+00	0.00000E+00
3	0.00000E+00	2.90706E-07
4	0.00000E+00	7.16754E-10
5	0.00000E+00	7.41041E-13
6	0.00000E+00	9.13884E-17
7	0.00000E+00	9.37636E-21

TOTAL SYSTEM UNRELIABILITY AT 1.00000E+01 HOURS = 2.91423E-07

Example Problem 4A Output

```

$FHMNAMES
  FHMNAME(1)= '(NONE)',
  FHMNAME(2)= 'PERMANENT'
$END
$FLTTYP
  NFTYPS=2,
  ALP=      0.0      ,      0.0      ,
  BET=      0.0      ,      0.0      ,
  DEL= 3600.0      ,      360.0      ,
  RHO=      0.0      ,      180.0      ,
  EPS=      0.0      ,      3600.0      ,
  IDELF=     1      ,      1      ,
  IRHOF=     1      ,      1      ,
  IEPSF=     1      ,      1      ,
  MARKOV=     1      ,
  PA=       1.0      ,      1.0      ,
  PB=       1.0      ,      0.0      ,
  C=        1.0      , 9.990000E-01,
  LGTMST=T
$END
$STGNAMES
  STGNAME(1)= 'INERTIAL REF',
  STGNAME(2)= 'PITCH RATE',
  STGNAME(3)= 'COMPUTER',
  STGNAME(4)= 'SECONDARY ACT'
$END
$STAGES
  NSTGES=4,
  N = 3, 3, 4, 3,
  M = 2, 2, 2, 2,
  NSUB= 0, 0, 0, 0,
  MSUB= 0, 0, 0, 0,
  LC= 0, 0, 0, 0,
  IRLPCD=1,
  RLPLT=F, IAXSRL=2
$END
$FLTCAT
  NFCATS=1,1,1,1,
  JTYP(1,1)= 1,
  JTYP(1,2)= 1,
  JTYP(1,3)= 2,
  JTYP(1,4)= 1,
  OMG(1,1)=      1.0      ,
  OMG(1,2)=      1.0      ,
  OMG(1,3)=      1.0      ,
  OMG(1,4)=      1.0      ,
  RLM(1,1)= 1.500000E-05,
  RLM(1,2)= 1.900000E-05,
  RLM(1,3)= 4.800000E-04,
  RLM(1,4)= 3.700000E-05
$END
$RNTIME
  FT= 10.0000      ,ITBASE=1,
  PSTRNC= 0.100000E-09,
  QPTRNC= 0.100000E-01,

```

Example Problem 4A Output

NPSBRN=20,
 CKDATA=T,
 SYSFLG=T,CPLFLG=F
 \$END
 SYSTEM TREE EX 4A
 1 4 5 5
 5 0 1 2 3 4

S U M M A R Y I N F O R M A T I O N :

	<u>TIME</u> (HOURS)	<u>Q SUM</u>	<u>P* SUM</u>	<u>Q SUM +</u> <u>P* SUM</u>
1	0.00000E+00	0.00000E+00	0.00000E+00	0.00000E+00
2	4.90196E-03	1.80761E-09	1.40983E-13	1.80775E-09
3	9.80392E-03	4.88157E-09	5.64142E-13	4.88213E-09
4	1.47059E-02	7.99450E-09	1.26979E-12	7.99577E-09
5	1.96078E-02	1.11239E-08	2.25824E-12	1.11261E-08
6	2.45098E-02	1.42547E-08	3.52979E-12	1.42583E-08
7	2.94118E-02	1.73859E-08	5.08478E-12	1.73910E-08
8	3.43137E-02	2.05173E-08	6.92350E-12	2.05242E-08
9	3.92157E-02	2.36488E-08	9.04627E-12	2.36578E-08
10	4.90196E-02	2.99116E-08	1.41452E-11	2.99257E-08
11	5.88235E-02	3.61744E-08	2.03841E-11	3.61948E-08
12	6.86275E-02	4.24372E-08	2.77654E-11	4.24650E-08
13	7.84314E-02	4.87000E-08	3.62917E-11	4.87362E-08
14	8.82353E-02	5.49627E-08	4.59654E-11	5.50086E-08
15	9.80392E-02	6.12254E-08	5.67891E-11	6.12822E-08
16	1.07843E-01	6.74881E-08	6.87652E-11	6.75568E-08
17	1.17647E-01	7.37507E-08	8.18962E-11	7.38326E-08
18	1.37255E-01	8.62759E-08	1.11633E-10	8.63875E-08
19	1.56863E-01	9.88010E-08	1.46020E-10	9.89470E-08
20	1.76471E-01	1.11326E-07	1.85076E-10	1.11511E-07
21	1.96078E-01	1.23851E-07	2.28822E-10	1.24080E-07
22	2.15686E-01	1.36375E-07	2.77278E-10	1.36653E-07
23	2.35294E-01	1.48900E-07	3.30463E-10	1.49231E-07
24	2.54902E-01	1.61425E-07	3.88398E-10	1.61813E-07
25	2.74510E-01	1.73949E-07	4.51103E-10	1.74400E-07
26	3.13726E-01	1.98997E-07	5.90900E-10	1.99588E-07
27	3.52941E-01	2.24045E-07	7.50016E-10	2.24795E-07
28	3.92157E-01	2.49093E-07	9.28610E-10	2.50021E-07
29	4.31373E-01	2.74140E-07	1.12684E-09	2.75266E-07
30	4.70588E-01	2.99186E-07	1.34487E-09	3.00531E-07

Example Problem 4A Output

31	5.09804E-01	3.24232E-07	1.58285E-09	3.25815E-07
32	5.49020E-01	3.49278E-07	1.84096E-09	3.51119E-07
33	5.88235E-01	3.74323E-07	2.11933E-09	3.76442E-07
34	6.66667E-01	4.24411E-07	2.73755E-09	4.27149E-07
35	7.45098E-01	4.74498E-07	3.43879E-09	4.77937E-07
36	8.23529E-01	5.24583E-07	4.22433E-09	5.28807E-07
37	9.01961E-01	5.74666E-07	5.09543E-09	5.79762E-07
38	9.80392E-01	6.24747E-07	6.05338E-09	6.30801E-07
39	1.05882E+00	6.74827E-07	7.09945E-09	6.81926E-07
40	1.13725E+00	7.24904E-07	8.23491E-09	7.33139E-07
41	1.21569E+00	7.74980E-07	9.46104E-09	7.84441E-07
42	1.37255E+00	8.75125E-07	1.21904E-08	8.87315E-07
43	1.52941E+00	9.75263E-07	1.52977E-08	9.90560E-07
44	1.68627E+00	1.07539E-06	1.87931E-08	1.09419E-06
45	1.84314E+00	1.17552E-06	2.26868E-08	1.19820E-06
46	2.00000E+00	1.27563E-06	2.69889E-08	1.30262E-06
47	2.15686E+00	1.37574E-06	3.17093E-08	1.40745E-06
48	2.31373E+00	1.47584E-06	3.68588E-08	1.51270E-06
49	2.47059E+00	1.57593E-06	4.24474E-08	1.61838E-06
50	2.78431E+00	1.77609E-06	5.49808E-08	1.83107E-06
51	3.09804E+00	1.97622E-06	6.93917E-08	2.04561E-06
52	3.41176E+00	2.17632E-06	8.57613E-08	2.26208E-06
53	3.72549E+00	2.37639E-06	1.04168E-07	2.48056E-06
54	4.03922E+00	2.57643E-06	1.24696E-07	2.70113E-06
55	4.35294E+00	2.77644E-06	1.47421E-07	2.92386E-06
56	4.66667E+00	2.97642E-06	1.72428E-07	3.14885E-06
57	4.98039E+00	3.17637E-06	1.99797E-07	3.37617E-06
58	5.60784E+00	3.57618E-06	2.61933E-07	3.83811E-06
59	6.23529E+00	3.97586E-06	3.34470E-07	4.31033E-06
60	6.86274E+00	4.37542E-06	4.18051E-07	4.79347E-06
61	7.49020E+00	4.77486E-06	5.13315E-07	5.28817E-06
62	8.11765E+00	5.17417E-06	6.20889E-07	5.79506E-06
63	8.74510E+00	5.57337E-06	7.41404E-07	6.31477E-06
64	9.37255E+00	5.97243E-06	8.75503E-07	6.84794E-06
65	1.00000E+01	6.37138E-06	1.02382E-06	7.39520E-06

K AFTER EXACTLY K STAGES HAVE FAILED BY 1.00000E+01 HOURS, PORTION OF THE UNRELIABILITY CAUSED BY: FAILURES

	FAULT HANDLING	EXHAUSTION OF MODULES
0	6.37138E-06	0.00000E+00
1	X	1.02382E-06
2	X	3.35975E-13
3	X	1.94468E-20

TOTAL SYSTEM UNRELIABILITY AT 1.00000E+01 HOURS = 7.39520E-06

Example Problem 4B Output

\$FHMNAMES

FHMNAME(1)= '(NONE)',
 FHMNAME(2)= 'PERMANENT'

\$END

\$FLITYP

NFTYPS=2,
 ALP= 0.0 , 0.0 ,
 BET= 0.0 , 0.0 ,
 DEL= 3600.0 , 360.0 ,
 RHO= 0.0 , 180.0 ,
 EPS= 0.0 , 3600.0 ,
 IDELF= 1 , 2 ,
 IRHOF= 1 , 2 ,
 IEPSF= 1 , 2 ,
 MARKOV= 2 ,
 PA= 1.0 , 1.0 ,
 PB= 1.0 , 0.0 ,
 C= 1.0 , 9.990000E-01,
 DBLDF= 0.500000E-01,TRUNC= 0.100000E-03,
 LGTMST=T

\$END

\$STGNAMES

STGNAME(1)= 'INERTIAL REF',
 STGNAME(2)= 'PITCH RATE',
 STGNAME(3)= 'COMPUTER',
 STGNAME(4)= 'SECONDARY ACT'

\$END

\$STAGES

NSTGES=4,
 N = 3, 3, 4, 3,
 M = 2, 2, 2, 2,
 NSUB= 0, 0, 0, 0,
 MSUB= 0, 0, 0, 0,
 LC= 0, 0, 0, 0,
 IRLPCD=1,
 RLPLT=F, IAXSRL=2

\$END

\$FLTCAT

NFCATS=1,1,1,1,
 JTYP(1,1)= 1,
 JTYP(1,2)= 1,
 JTYP(1,3)= 2,
 JTYP(1,4)= 1,
 OMG(1,1)= 1.0 ,
 OMG(1,2)= 1.0 ,
 OMG(1,3)= 1.0 ,
 OMG(1,4)= 1.0 ,
 RLM(1,1)= 1.500000E-05,
 RLM(1,2)= 1.900000E-05,
 RLM(1,3)= 4.800000E-04,
 RLM(1,4)= 3.700000E-05

\$END

\$RNTIME

FT= 10.0000 ,ITBASE=1,
 PSTRNC= 0.100000E-09,

Example Problem 4B Output

QPTRNC= 0.100000E-01,
 NPSBRN=20,
 CKDATA=T,
 SYSFLG=T,CPLFLG=F

\$END

SYSTEM TREE EX 4A

1 4 5 5

5 0 1 2 3 4

S U M M A R Y I N F O R M A T I O N :

	<u>T I M E</u> <u>(HOURS)</u>	<u>Q S U M</u>	<u>P* S U M</u>	<u>Q S U M +</u> <u>P* S U M</u>
1	0.00000E+00	0.00000E+00	0.00000E+00	0.00000E+00
2	4.90196E-03	1.84423E-09	1.40983E-13	1.84437E-09
3	9.80392E-03	4.75017E-09	5.64142E-13	4.75074E-09
4	1.47059E-02	7.55977E-09	1.26979E-12	7.56104E-09
5	1.96078E-02	1.03910E-08	2.25824E-12	1.03932E-08
6	2.45098E-02	1.32222E-08	3.52979E-12	1.32257E-08
7	2.94118E-02	1.60534E-08	5.08478E-12	1.60585E-08
8	3.43137E-02	1.88846E-08	6.92350E-12	1.88915E-08
9	3.92157E-02	2.17158E-08	9.04627E-12	2.17248E-08
10	4.90196E-02	2.73781E-08	1.41452E-11	2.73923E-08
11	5.88235E-02	3.30405E-08	2.03841E-11	3.30608E-08
12	6.86275E-02	3.87028E-08	2.77654E-11	3.87305E-08
13	7.84314E-02	4.43650E-08	3.62917E-11	4.44013E-08
14	8.82353E-02	5.00273E-08	4.59654E-11	5.00732E-08
15	9.80392E-02	5.56895E-08	5.67891E-11	5.57463E-08
16	1.07843E-01	6.13517E-08	6.87652E-11	6.14205E-08
17	1.17647E-01	6.70139E-08	8.18962E-11	6.70957E-08
18	1.37255E-01	7.83381E-08	1.11633E-10	7.84497E-08
19	1.56863E-01	8.96623E-08	1.46020E-10	8.98083E-08
20	1.76471E-01	1.00986E-07	1.85076E-10	1.01171E-07
21	1.96078E-01	1.12310E-07	2.28822E-10	1.12539E-07
22	2.15686E-01	1.23634E-07	2.77278E-10	1.23911E-07
23	2.35294E-01	1.34958E-07	3.30463E-10	1.35288E-07
24	2.54902E-01	1.46281E-07	3.88398E-10	1.46670E-07
25	2.74510E-01	1.57605E-07	4.51103E-10	1.58056E-07
26	3.13726E-01	1.80252E-07	5.90900E-10	1.80843E-07
27	3.52941E-01	2.02898E-07	7.50016E-10	2.03648E-07
28	3.92157E-01	2.25544E-07	9.28610E-10	2.26472E-07
29	4.31373E-01	2.48189E-07	1.12684E-09	2.49316E-07
30	4.70588E-01	2.70834E-07	1.34487E-09	2.72179E-07

Example Problem 4B Output

31	5.09804E-01	2.93479E-07	1.58285E-09	2.95062E-07
32	5.49020E-01	3.16123E-07	1.84096E-09	3.17964E-07
33	5.88235E-01	3.38767E-07	2.11933E-09	3.40886E-07
34	6.66667E-01	3.84053E-07	2.73755E-09	3.86790E-07
35	7.45098E-01	4.29337E-07	3.43879E-09	4.32776E-07
36	8.23529E-01	4.74620E-07	4.22433E-09	4.78844E-07
37	9.01961E-01	5.19901E-07	5.09543E-09	5.24996E-07
38	9.80392E-01	5.65180E-07	6.05338E-09	5.71233E-07
39	1.05882E+00	6.10458E-07	7.09945E-09	6.17557E-07
40	1.13725E+00	6.55734E-07	8.23491E-09	6.63968E-07
41	1.21569E+00	7.01008E-07	9.46104E-09	7.10469E-07
42	1.37255E+00	7.91551E-07	1.21904E-08	8.03741E-07
43	1.52941E+00	8.82087E-07	1.52977E-08	8.97385E-07
44	1.68627E+00	9.72617E-07	1.87931E-08	9.91410E-07
45	1.84314E+00	1.06314E-06	2.26868E-08	1.08583E-06
46	2.00000E+00	1.15366E-06	2.69889E-08	1.18064E-06
47	2.15686E+00	1.24416E-06	3.17093E-08	1.27587E-06
48	2.31373E+00	1.33467E-06	3.68588E-08	1.37153E-06
49	2.47059E+00	1.42516E-06	4.24474E-08	1.46761E-06
50	2.78431E+00	1.60613E-06	5.49808E-08	1.66111E-06
51	3.09804E+00	1.78707E-06	6.93917E-08	1.85647E-06
52	3.41176E+00	1.96799E-06	8.57613E-08	2.05375E-06
53	3.72549E+00	2.14888E-06	1.04168E-07	2.25304E-06
54	4.03922E+00	2.32974E-06	1.24696E-07	2.45443E-06
55	4.35294E+00	2.51057E-06	1.47421E-07	2.65799E-06
56	4.66667E+00	2.69137E-06	1.72428E-07	2.86380E-06
57	4.98039E+00	2.87215E-06	1.99797E-07	3.07195E-06
58	5.60784E+00	3.23362E-06	2.61933E-07	3.49555E-06
59	6.23529E+00	3.59498E-06	3.34470E-07	3.92945E-06
60	6.86274E+00	3.95623E-06	4.18051E-07	4.37428E-06
61	7.49020E+00	4.31737E-06	5.13315E-07	4.83069E-06
62	8.11765E+00	4.67840E-06	6.20889E-07	5.29929E-06
63	8.74510E+00	5.03932E-06	7.41404E-07	5.78072E-06
64	9.37255E+00	5.40012E-06	8.75503E-07	6.27563E-06
65	1.00000E+01	5.76082E-06	1.02382E-06	6.78464E-06

K AFTER EXACTLY K STAGES HAVE FAILED BY 1.00000E+01 HOURS, PORTION OF THE UNRELIABILITY CAUSED BY: FAILURES

	FAULT HANDLING	EXHAUSTION OF MODULES
0	5.76082E-06	0.00000E+00
1	X	1.02382E-06
2	X	3.35975E-13
3	X	1.94468E-20

TOTAL SYSTEM UNRELIABILITY AT 1.00000E+01 HOURS = 6.78464E-06

Example Problem 5 Output

\$FHMNAMES

FHMNAME(1)= '(NONE)',
 FHMNAME(2)= 'PERMANENT',
 FHMNAME(3)= 'TRANSIENT',
 FHMNAME(4)= 'INTERMITTENT'

\$END

\$FLITYP

NFTYPS=4,
 ALP= 0.0 , 0.0 , 36000.0 , 2100.0 ,
 BET= 0.0 , 0.0 , 0.0 , 3000.0 ,
 DEL= 3600.0 , 360.0 , 360.0 , 360.0 ,
 RHO= 0.0 , 180.0 , 180.0 , 180.0 ,
 EPS= 0.0 , 3600.0 , 3600.0 , 3600.0 ,
 IDELF= 1 , 1 , 1 , 1 ,
 IRHOF= 1 , 1 , 1 , 1 ,
 IEPF= 1 , 1 , 1 , 1 ,
 MARKOV= 1 ,
 PA= 1.0 , 1.0 , 1.0 , 0.9 ,
 PB= 1.0 , 0.0 , 0.0 , 0.1 ,
 C= 1.0 , 9.990000E-01, 9.990000E-01, 9.990000E-01,
 LGTMST=T

\$END

\$STGNAMES

STGNAME(1)= 'INERTIAL REF',
 STGNAME(2)= 'PITCH RATE',
 STGNAME(3)= 'DIGITAL COMPUTER',
 STGNAME(4)= 'SWITCH',
 STGNAME(5)= 'ANALOG COMPUTER',
 STGNAME(6)= 'SECONDARY ACTUATOR'

\$END

\$STAGES

NSTGES=6,
 N = 3, 3, 4, 1, 1, 3,
 M = 2, 2, 2, 1, 1, 2,
 NSUB= 0, 0, 0, 0, 0, 0,
 MSUB= 0, 0, 0, 0, 0, 0,
 LC= 0, 0, 0, 0, 0, 0,
 IRLPCD=1,
 RLPLT=F, IAXSRL=2

\$END

\$FLTCAT

NFCATS=1,1,3,1,1,1,
 JTYP(1,1)= 1,
 JTYP(1,2)= 1,
 JTYP(1,3)= 2, 3, 4,
 JTYP(1,4)= 1,
 JTYP(1,5)= 1,
 JTYP(1,6)= 1,
 OMG(1,1)= 1.0 ,
 OMG(1,2)= 1.0 ,
 OMG(1,3)= 1.0 , 1.0 , 1.0 ,
 OMG(1,4)= 1.0 ,
 OMG(1,5)= 1.0 ,
 OMG(1,6)= 1.0 ,
 RLM(1,1)= 1.500000E-05,

Example Problem 5 Output

RLM(1,2)= 1.900000E-05,
 RLM(1,3)= 4.800000E-04, 7.200000E-03, 3.300000E-04,
 RLM(1,4)= 1.700000E-10,
 RLM(1,5)= 2.300000E-09,
 RLM(1,6)= 3.700000E-05

\$END

\$RNTIME

FT= 10.0000 ,ITBASE=1,
 PSTRNC= 0.100000E-09,
 QPTRNC= 0.100000E-01,
 NPSBRN=20,
 CKDATA=T,
 SYSFLG=T,CPLFLG=F

\$END

SYSTEM TREE EX 5

1 6 7 9
 7 0 4 5
 8 A 3 7
 9 0 1 2 8 6

S U M M A R Y I N F O R M A T I O N :

	<u>T I M E</u> (HOURS)	<u>Q S U M</u>	<u>P* S U M</u>	<u>Q S U M +</u> <u>P* S U M</u>
1	0.00000E+00	0.00000E+00	0.00000E+00	0.00000E+00
2	4.90196E-03	3.23215E-09	1.40931E-13	3.23229E-09
3	9.80392E-03	9.02385E-09	5.63725E-13	9.02441E-09
4	1.47059E-02	1.51479E-08	1.26838E-12	1.51492E-08
5	1.96078E-02	2.13864E-08	2.25490E-12	2.13886E-08
6	2.45098E-02	2.76537E-08	3.52328E-12	2.76573E-08
7	2.94118E-02	3.39292E-08	5.07352E-12	3.39343E-08
8	3.43137E-02	4.02072E-08	6.90563E-12	4.02141E-08
9	3.92157E-02	4.64857E-08	9.01959E-12	4.64948E-08
10	4.90196E-02	5.90429E-08	1.40931E-11	5.90570E-08
11	5.88235E-02	7.16000E-08	2.02941E-11	7.16202E-08
12	6.86275E-02	8.41569E-08	2.76225E-11	8.41845E-08
13	7.84314E-02	9.67138E-08	3.60783E-11	9.67499E-08
14	8.82353E-02	1.09271E-07	4.56616E-11	1.09316E-07
15	9.80392E-02	1.21827E-07	5.63723E-11	1.21884E-07
16	1.07843E-01	1.34384E-07	6.82104E-11	1.34452E-07
17	1.17647E-01	1.46940E-07	8.11760E-11	1.47021E-07
18	1.37255E-01	1.72053E-07	1.10489E-10	1.72163E-07
19	1.56863E-01	1.97165E-07	1.44313E-10	1.97309E-07
20	1.76471E-01	2.22276E-07	1.82645E-10	2.22459E-07
21	1.96078E-01	2.47387E-07	2.25488E-10	2.47613E-07

Example Problem 5 Output

22	2.15686E-01	2.72498E-07	2.72840E-10	2.72771E-07
23	2.35294E-01	2.97609E-07	3.24702E-10	2.97933E-07
24	2.54902E-01	3.22719E-07	3.81073E-10	3.23100E-07
25	2.74510E-01	3.47828E-07	4.41955E-10	3.48270E-07
26	3.13726E-01	3.98046E-07	5.77246E-10	3.98623E-07
27	3.52941E-01	4.48262E-07	7.30575E-10	4.48992E-07
28	3.92157E-01	4.98476E-07	9.01943E-10	4.99378E-07
29	4.31373E-01	5.48688E-07	1.09135E-09	5.49779E-07
30	4.70588E-01	5.98899E-07	1.29879E-09	6.00198E-07
31	5.09804E-01	6.49108E-07	1.52427E-09	6.50632E-07
32	5.49020E-01	6.99315E-07	1.76779E-09	7.01083E-07
33	5.88235E-01	7.49520E-07	2.02935E-09	7.51550E-07
34	6.66667E-01	8.49926E-07	2.60658E-09	8.52533E-07
35	7.45098E-01	9.50325E-07	3.25595E-09	9.53581E-07
36	8.23529E-01	1.05072E-06	3.97748E-09	1.05469E-06
37	9.01961E-01	1.15110E-06	4.77115E-09	1.15587E-06
38	9.80392E-01	1.25148E-06	5.63697E-09	1.25712E-06
39	1.05882E+00	1.35185E-06	6.57493E-09	1.35843E-06
40	1.13725E+00	1.45221E-06	7.58504E-09	1.45980E-06
41	1.21569E+00	1.55257E-06	8.66730E-09	1.56124E-06
42	1.37255E+00	1.75327E-06	1.10482E-08	1.76431E-06
43	1.52941E+00	1.95393E-06	1.37177E-08	1.96765E-06
44	1.68627E+00	2.15457E-06	1.66758E-08	2.17125E-06
45	1.84314E+00	2.35518E-06	1.99224E-08	2.37510E-06
46	2.00000E+00	2.55576E-06	2.34576E-08	2.57922E-06
47	2.15686E+00	2.75632E-06	2.72813E-08	2.78360E-06
48	2.31373E+00	2.95684E-06	3.13935E-08	2.98824E-06
49	2.47059E+00	3.15734E-06	3.57942E-08	3.19314E-06
50	2.78431E+00	3.55826E-06	4.54613E-08	3.60372E-06
51	3.09804E+00	3.95906E-06	5.62823E-08	4.01535E-06
52	3.41176E+00	4.35976E-06	6.82573E-08	4.42801E-06
53	3.72549E+00	4.76034E-06	8.13862E-08	4.84173E-06
54	4.03922E+00	5.16081E-06	9.56690E-08	5.25648E-06
55	4.35294E+00	5.56117E-06	1.11105E-07	5.67228E-06
56	4.66667E+00	5.96143E-06	1.27696E-07	6.08912E-06
57	4.98039E+00	6.36157E-06	1.45440E-07	6.50700E-06
58	5.60784E+00	7.16151E-06	1.84388E-07	7.34590E-06
59	6.23529E+00	7.96102E-06	2.27951E-07	8.18897E-06
60	6.86274E+00	8.76008E-06	2.76127E-07	9.03621E-06
61	7.49020E+00	9.55871E-06	3.28916E-07	9.88762E-06
62	8.11765E+00	1.03569E-05	3.86318E-07	1.07432E-05
63	8.74510E+00	1.11546E-05	4.48333E-07	1.16030E-05
64	9.37255E+00	1.19519E-05	5.14958E-07	1.24669E-05
65	1.00000E+01	1.27488E-05	5.86196E-07	1.33350E-05

Example Problem 5 Output

K STAGE FAILURES	AFTER EXACTLY K STAGES HAVE FAILED BY 1.00000E+01 HOURS, PORTION OF THE UNRELIABILITY CAUSED BY:	
	FAULT HANDLING	EXHAUSTION OF MODULES
0	1.27479E-05	0.00000E+00
1	8.91028E-10	5.86194E-07
2	X	1.73487E-12
3	X	1.19365E-19

TOTAL SYSTEM UNRELIABILITY AT 1.00000E+01 HOURS = 1.33350E-05

Example Problem 6 Output

\$FHMNAMES

FHMNAME(1)= '(NONE)',
 FHMNAME(2)= 'PERMANENT'

\$END

\$FLTTYP

NFTYPS=2,
 ALP= 0.0 , 0.0 ,
 BET= 0.0 , 0.0 ,
 DEL= 3600.0 , 360.0 ,
 RHO= 0.0 , 180.0 ,
 EPS= 0.0 , 3600.0 ,
 IDELF= 1 , 1 ,
 IRHOF= 1 , 1 ,
 IEPSF= 1 , 1 ,
 MARKOV= 1 , ,
 PA= 1.0 , 1.0 ,
 PB= 1.0 , 0.0 ,
 C= 1.0 , 9.990000E-01,
 LGTMST=T

\$END

\$STGNAMES

STGNAME(1)= 'INERTIAL REF',
 STGNAME(2)= 'PTICH RATE',
 STGNAME(3)= 'COMPUTER',
 STGNAME(4)= 'SECONDARY ACTUATOR'

\$END

\$STAGES

NSTGES=4,
 N = 3, 3, 4, 3,
 M = 2, 2, 2, 2,
 NSUB= 0, 0, 0, 0,
 MSUB= 0, 0, 0, 0,
 LC= 0, 0, 0, 0,
 NOP(1,3)=3,
 IRLPCD=1,
 RLPLOT=F, IAXSRL=2

\$END

\$FLTCAT

NFCATS=1,1,1,1,
 JTYP(1,1)= 1,
 JTYP(1,2)= 1,
 JTYP(1,3)= 2,
 JTYP(1,4)= 1,
 OMG(1,1)= 1.0 ,
 OMG(1,2)= 1.0 ,
 OMG(1,3)= 1.0 ,
 OMG(1,4)= 1.0 ,
 RLM(1,1)= 1.500000E-05,
 RLM(1,2)= 1.900000E-05,
 RLM(1,3)= 4.800000E-04,
 RLM(1,4)= 3.700000E-05

\$END

\$RNTIME

FT= 10.0000 ,ITBASE=1,
 PSTRNC= 0.100000E-09,

Example Problem 6 Output

QPTRNC= 0.100000E-01,
 NPSBRN=20,
 CKDATA=T,
 SYSFLG=T,CPLFLG=T

\$END
 SYSTEM TREE EX 6
 1 4 5 5
 5 0 1 2 3 4
 CRITICAL PAIRS TREE EX 6
 1 4 5 5
 3 1 4
 5 2 1 2 3

S U M M A R Y I N F O R M A T I O N :

	<u>T I M E</u> (HOURS)	<u>Q S U M</u>	<u>P* S U M</u>	<u>Q S U M +</u> <u>P* S U M</u>
1	0.00000E+00	0.00000E+00	0.00000E+00	0.00000E+00
2	4.90196E-03	1.81538E-09	1.40983E-13	1.81552E-09
3	9.80392E-03	4.90239E-09	5.64142E-13	4.90296E-09
4	1.47059E-02	8.02845E-09	1.26979E-12	8.02972E-09
5	1.96078E-02	1.11710E-08	2.25824E-12	1.11733E-08
6	2.45098E-02	1.43151E-08	3.52979E-12	1.43186E-08
7	2.94118E-02	1.74595E-08	5.08478E-12	1.74646E-08
8	3.43137E-02	2.06041E-08	6.92350E-12	2.06110E-08
9	3.92157E-02	2.37487E-08	9.04627E-12	2.37578E-08
10	4.90196E-02	3.00380E-08	1.41452E-11	3.00522E-08
11	5.88235E-02	3.63272E-08	2.03841E-11	3.63476E-08
12	6.86275E-02	4.26164E-08	2.77654E-11	4.26442E-08
13	7.84314E-02	4.89056E-08	3.62917E-11	4.89419E-08
14	8.82353E-02	5.51948E-08	4.59654E-11	5.52407E-08
15	9.80392E-02	6.14839E-08	5.67891E-11	6.15407E-08
16	1.07843E-01	6.77730E-08	6.87652E-11	6.78417E-08
17	1.17647E-01	7.40620E-08	8.18962E-11	7.41439E-08
18	1.37255E-01	8.66400E-08	1.11633E-10	8.67517E-08
19	1.56863E-01	9.92179E-08	1.46020E-10	9.93640E-08
20	1.76471E-01	1.11796E-07	1.85076E-10	1.11981E-07
21	1.96078E-01	1.24373E-07	2.28822E-10	1.24602E-07
22	2.15686E-01	1.36951E-07	2.77278E-10	1.37228E-07
23	2.35294E-01	1.49528E-07	3.30463E-10	1.49859E-07
24	2.54902E-01	1.62106E-07	3.88398E-10	1.62494E-07
25	2.74510E-01	1.74683E-07	4.51103E-10	1.75134E-07
26	3.13726E-01	1.99837E-07	5.90900E-10	2.00428E-07
27	3.52941E-01	2.24990E-07	7.50016E-10	2.25740E-07

Example Problem 6 Output

28	3.92157E-01	2.50143E-07	9.28610E-10	2.51072E-07
29	4.31373E-01	2.75296E-07	1.12684E-09	2.76423E-07
30	4.70588E-01	3.00448E-07	1.34487E-09	3.01793E-07
31	5.09804E-01	3.25600E-07	1.58285E-09	3.27182E-07
32	5.49020E-01	3.50751E-07	1.84096E-09	3.52592E-07
33	5.88235E-01	3.75901E-07	2.11933E-09	3.78021E-07
34	6.66667E-01	4.26201E-07	2.73755E-09	4.28939E-07
35	7.45098E-01	4.76499E-07	3.43879E-09	4.79938E-07
36	8.23529E-01	5.26795E-07	4.22433E-09	5.31019E-07
37	9.01961E-01	5.77089E-07	5.09543E-09	5.82185E-07
38	9.80392E-01	6.27381E-07	6.05338E-09	6.33435E-07
39	1.05882E+00	6.77672E-07	7.09945E-09	6.84771E-07
40	1.13725E+00	7.27960E-07	8.23491E-09	7.36195E-07
41	1.21569E+00	7.78246E-07	9.46104E-09	7.87707E-07
42	1.37255E+00	8.78813E-07	1.21904E-08	8.91004E-07
43	1.52941E+00	9.79373E-07	1.52977E-08	9.94670E-07
44	1.68627E+00	1.07992E-06	1.87931E-08	1.09872E-06
45	1.84314E+00	1.18047E-06	2.26868E-08	1.20315E-06
46	2.00000E+00	1.28100E-06	2.69889E-08	1.30799E-06
47	2.15686E+00	1.38153E-06	3.17093E-08	1.41324E-06
48	2.31373E+00	1.48205E-06	3.68588E-08	1.51891E-06
49	2.47059E+00	1.58257E-06	4.24474E-08	1.62501E-06
50	2.78431E+00	1.78357E-06	5.49808E-08	1.83855E-06
51	3.09804E+00	1.98454E-06	6.93917E-08	2.05393E-06
52	3.41176E+00	2.18548E-06	8.57613E-08	2.27124E-06
53	3.72549E+00	2.38639E-06	1.04168E-07	2.49056E-06
54	4.03922E+00	2.58727E-06	1.24696E-07	2.71197E-06
55	4.35294E+00	2.78812E-06	1.47421E-07	2.93554E-06
56	4.66667E+00	2.98894E-06	1.72428E-07	3.16137E-06
57	4.98039E+00	3.18972E-06	1.99797E-07	3.38952E-06
58	5.60784E+00	3.59120E-06	2.61933E-07	3.85314E-06
59	6.23529E+00	3.99256E-06	3.34470E-07	4.32703E-06
60	6.86274E+00	4.39379E-06	4.18051E-07	4.81184E-06
61	7.49020E+00	4.79489E-06	5.13315E-07	5.30821E-06
62	8.11765E+00	5.19588E-06	6.20889E-07	5.81677E-06
63	8.74510E+00	5.59673E-06	7.41404E-07	6.33814E-06
64	9.37255E+00	5.99746E-06	8.75503E-07	6.87297E-06
65	1.00000E+01	6.39807E-06	1.02382E-06	7.42189E-06

Example Problem 6 Output

K AFTER EXACTLY K STAGES HAVE FAILED BY 1.00000E+01
STAGE HOURS, PORTION OF THE UNRELIABILITY CAUSED BY:
FAILURES

	FAULT HANDLING	EXHAUSTION OF MODULES
	-----	-----
0	6.39807E-06	0.00000E+00
1	X	1.02382E-06
2	X	3.35975E-13
3	X	1.94468E-20

TOTAL SYSTEM UNRELIABILITY AT 1.00000E+01 HOURS = 7.42189E-06

Example Problem 7 Output

```

$FHMNAMES
  FHMNAME(1)= '(NONE)',
  FHMNAME(2)= 'PERMANENT C',
  FHMNAME(3)= 'PERMANENT B'
$END
$FLTTYF
  NTTYPS=3,
  ALP=      0.0      ,      0.0      ,      0.0      ,
  BET=      0.0      ,      0.0      ,      0.0      ,
  DEL= 3600.0      ,      360.0      ,      10000.0      ,
  RHO=      0.0      ,      180.0      ,      0.0      ,
  EPS=      0.0      ,      3600.0      ,      0.0      ,
  IDELF=     1      ,      1      ,      1      ,
  IRHOF=     1      ,      1      ,      1      ,
  IEPSF=     1      ,      1      ,      1      ,
  MARKOV=    1      ,
  PA=       1.0      ,      1.0      ,      1.0      ,
  PB=       1.0      ,      0.0      ,      0.0      ,
  C=        1.0      ,      9.990000E-01,      1.0      ,
  LGTMST=T
$END
$STGNAMES
  STGNAME(1)= 'INERTIAL REF',
  STGNAME(2)= 'PITCH RATE',
  STGNAME(3)= 'COMPUTER',
  STGNAME(4)= 'SECONDARY ACT',
  STGNAME(5)= 'COMPUTER BUS'
$END
$STAGES
  NSTGES=5,
  N = 3, 3, 4, 3, 4,
  M = 2, 2, 2, 2, 2,
  NSUB= 0, 0, 0, 0, 0,
  MSUB= 0, 0, 0, 0, 0,
  LC= 0, 0, 0, 0, 0,
  NOP(1,3)=3,
  NOP(1,5)=3,
  IRLPCD=1,
  RLPLT=F, IAXSRL=2
$END
$FLTCAT
  NFCATS=1,1,1,1,1,
  JTYP(1,1)= 1,
  JTYP(1,2)= 1,
  JTYP(1,3)= 2,
  JTYP(1,4)= 1,
  JTYP(1,5)= 3,
  OMG(1,1)= 1.0      ,
  OMG(1,2)= 1.0      ,
  OMG(1,3)= 1.0      ,
  OMG(1,4)= 1.0      ,
  OMG(1,5)= 1.0      ,

```

Example Problem 7 Output

```

RLM(1,1)= 1.500000E-05,
RLM(1,2)= 1.900000E-05,
RLM(1,3)= 4.800000E-04,
RLM(1,4)= 3.700000E-05,
RLM(1,5)= 2.700000E-06
$END
$RNTIME
  FT= 10.0000 ,ITBASE=1,
  PSTRNC= 0.100000E-09,
  QPTRNC= 0.100000E-01,
  NPSBRN=20,
  CKDATA=T,
  SYSFLG=T,CPLFLG=T

```

```

$END
SYSTEM TREE EX 7
1 5 6 6
6 0 1 2 3 4 5
CRITICAL PAIRS TREE EX 7
1 8 9 18
3 1 4
5 5 8
9 0 2 3
10 0 1 3
11 0 1 2
12 A 9 5
13 A 10 6
14 A 11 7
15 2 1 2 3
16 2 5 6 7
17 0 12 13 14
18 0 15 16 17

```

S U M M A R Y I N F O R M A T I O N :

	<u>T I M E</u> (HOURS)	<u>Q S U M</u>	<u>P* S U M</u>	<u>Q S U M +</u> <u>P* S U M</u>
1	0.00000E+00	0.00000E+00	0.00000E+00	0.00000E+00
2	4.90196E-03	1.80761E-09	1.40983E-13	1.80775E-09
3	9.80392E-03	4.88157E-09	5.64142E-13	4.88213E-09
4	1.47059E-02	7.99450E-09	1.26979E-12	7.99577E-09
5	1.96078E-02	1.11239E-08	2.25824E-12	1.11261E-08
6	2.45098E-02	1.42547E-08	3.52979E-12	1.42583E-08
7	2.94118E-02	1.73859E-08	5.08478E-12	1.73910E-08
8	3.43137E-02	2.05173E-08	6.92350E-12	2.05242E-08
9	3.92157E-02	2.36488E-08	9.04627E-12	2.36578E-08
10	4.90196E-02	2.99116E-08	1.41452E-11	2.99257E-08

Example Problem 7 Output

11	5.88235E-02	3.61744E-08	2.03841E-11	3.61948E-08
12	6.86275E-02	4.24372E-08	2.77654E-11	4.24650E-08
13	7.84314E-02	4.87000E-08	3.62917E-11	4.87362E-08
14	8.82353E-02	5.49627E-08	4.59654E-11	5.50086E-08
15	9.80392E-02	6.12254E-08	5.67891E-11	6.12822E-08
16	1.07843E-01	6.74881E-08	6.87652E-11	6.75568E-08
17	1.17647E-01	7.37507E-08	8.18962E-11	7.38326E-08
18	1.37255E-01	8.62759E-08	1.11633E-10	8.63875E-08
19	1.56863E-01	9.88010E-08	1.46020E-10	9.89470E-08
20	1.76471E-01	1.11326E-07	1.85076E-10	1.11511E-07
21	1.96078E-01	1.23851E-07	2.28822E-10	1.24080E-07
22	2.15686E-01	1.36375E-07	2.77278E-10	1.36653E-07
23	2.35294E-01	1.48900E-07	3.30463E-10	1.49231E-07
24	2.54902E-01	1.61425E-07	3.88398E-10	1.61813E-07
25	2.74510E-01	1.73949E-07	4.51103E-10	1.74400E-07
26	3.13726E-01	1.98997E-07	5.90900E-10	1.99588E-07
27	3.52941E-01	2.24045E-07	7.50016E-10	2.24795E-07
28	3.92157E-01	2.49093E-07	9.28610E-10	2.50021E-07
29	4.31373E-01	2.74140E-07	1.12684E-09	2.75266E-07
30	4.70588E-01	2.99186E-07	1.34487E-09	3.00531E-07
31	5.09804E-01	3.24232E-07	1.58285E-09	3.25815E-07
32	5.49020E-01	3.49278E-07	1.84096E-09	3.51119E-07
33	5.88235E-01	3.74323E-07	2.11933E-09	3.76442E-07
34	6.66667E-01	4.24411E-07	2.73755E-09	4.27149E-07
35	7.45098E-01	4.74498E-07	3.43879E-09	4.77937E-07
36	8.23529E-01	5.24583E-07	4.22433E-09	5.28808E-07
37	9.01961E-01	5.74666E-07	5.09543E-09	5.79762E-07
38	9.80392E-01	6.24747E-07	6.05338E-09	6.30801E-07
39	1.05882E+00	6.74827E-07	7.09945E-09	6.81926E-07
40	1.13725E+00	7.24904E-07	8.23491E-09	7.33139E-07
41	1.21569E+00	7.74980E-07	9.46104E-09	7.84441E-07
42	1.37255E+00	8.75125E-07	1.21904E-08	8.87315E-07
43	1.52941E+00	9.75263E-07	1.52977E-08	9.90560E-07
44	1.68627E+00	1.07539E-06	1.87931E-08	1.09419E-06
45	1.84314E+00	1.17552E-06	2.26868E-08	1.19820E-06
46	2.00000E+00	1.27563E-06	2.69889E-08	1.30262E-06
47	2.15686E+00	1.37574E-06	3.17093E-08	1.40745E-06
48	2.31373E+00	1.47584E-06	3.68588E-08	1.51270E-06
49	2.47059E+00	1.57593E-06	4.24474E-08	1.61838E-06
50	2.78431E+00	1.77609E-06	5.49808E-08	1.83107E-06
51	3.09804E+00	1.97622E-06	6.93917E-08	2.04561E-06
52	3.41176E+00	2.17632E-06	8.57613E-08	2.26209E-06
53	3.72549E+00	2.37639E-06	1.04168E-07	2.48056E-06
54	4.03922E+00	2.57643E-06	1.24696E-07	2.70113E-06
55	4.35294E+00	2.77644E-06	1.47421E-07	2.92386E-06

Example Problem 7 Output

56	4.66667E+00	2.97642E-06	1.72428E-07	3.14885E-06
57	4.98039E+00	3.17637E-06	1.99797E-07	3.37617E-06
58	5.60784E+00	3.57618E-06	2.61933E-07	3.83811E-06
59	6.23529E+00	3.97586E-06	3.34470E-07	4.31033E-06
60	6.86274E+00	4.37542E-06	4.18051E-07	4.79347E-06
61	7.49020E+00	4.77486E-06	5.13315E-07	5.28817E-06
62	8.11765E+00	5.17417E-06	6.20889E-07	5.79506E-06
63	8.74510E+00	5.57337E-06	7.41404E-07	6.31477E-06
64	9.37255E+00	5.97243E-06	8.75503E-07	6.84794E-06
65	1.00000E+01	6.37138E-06	1.02382E-06	7.39520E-06

K AFTER EXACTLY K STAGES HAVE FAILED BY 1.00000E+01
 STAGE HOURS, PORTION OF THE UNRELIABILITY CAUSED BY:
 FAILURES

	FAULT HANDLING	EXHAUSTION OF MODULES
	-----	-----
0	6.37138E-06	0.00000E+00
1	X	1.02382E-06
2	X	3.35975E-13
3	X	1.94468E-20

TOTAL SYSTEM UNRELIABILITY AT 1.00000E+01 HOURS = 7.39520E-06

Example Problem 8 Output

\$FHMNAMES

FHMNAME(1)= '(NONE)',
 FHMNAME(2)= 'PERMANENT C',
 FHMNAME(3)= 'PERMANENT B',
 FHMNAME(4)= 'TRANSIENT',
 FHMNAME(5)= 'INTERMITTENT'

\$END

\$FLTTYF

NFTYPS=5,
 ALP= 0.0 , 0.0 , 0.0 , 36000.0 , 2100.0,
 BET= 0.0 , 0.0 , 0.0 , 0.0 , 3000.0,
 DEL= 3600.0 , 360.0 , 10000.0 , 360.0 , 360.0,
 RHO= 0.0 , 180.0 , 0.0 , 180.0 , 180.0,
 EPS= 0.0 , 3600.0 , 0.0 , 3600.0 , 3600.0,
 IDELF= 1 , 1 , 1 , 1 , 1 ,
 IRHOF= 1 , 1 , 1 , 1 , 1 ,
 IEPSF= 1 , 1 , 1 , 1 , 1 ,
 MARKOV= 1 ,
 PA= 1.0 , 1.0 , 1.0 , 1.0 , 1.0,
 PB= 1.0 , 0.0 , 0.0 , 0.0 , 0.0,
 C= 1.0 , 1.0 , 1.0 , 1.0 , 1.0,
 LGTMST=T

\$END

\$STGNAMES

STGNAME(1)= 'INERTIAL REF',
 STGNAME(2)= 'PITCH RATE',
 STGNAME(3)= 'DIGITAL COMPUTER',
 STGNAME(4)= 'SWITCH',
 STGNAME(5)= 'ANALOG COMPUTER',
 STGNAME(6)= 'SECONDARY ACTUATOR',
 STGNAME(7)= 'COMPUTER BUS'

\$END

\$STAGES

NSTGES=7,
 N = 3, 3, 4, 1, 1, 3, 4,
 M = 2, 2, 2, 1, 1, 2, 2,
 NSUB= 0, 0, 0, 0, 0, 0, 0,
 MSUB= 0, 0, 0, 0, 0, 0, 0,
 LC= 0, 0, 0, 0, 0, 0, 0,
 NOP(1,7)=3,
 IRLPCD=1,
 RLPLLOT=F, IAXSRL=2

\$END

\$FLTCAT

NFCATS=1,1,3,1,1,1,3,
 JTYP(1,1)= 1,
 JTYP(1,2)= 1,
 JTYP(1,3)= 2, 4, 5,
 JTYP(1,4)= 1,
 JTYP(1,5)= 1,
 JTYP(1,6)= 1,
 JTYP(1,7)= 3, 4, 5,
 OMG(1,1)= 1.0 ,
 OMG(1,2)= 1.0 ,
 OMG(1,3)= 1.0 , 1.0 , 1.0 ,

Example Problem 8 Output

```

OMG(1,4)=      1.0      ,
OMG(1,5)=      1.0      ,
OMG(1,6)=      1.0      ,
OMG(1,7)=      1.0      ,      1.0      ,      1.0      ,
RLM(1,1)= 1.500000E-05,
RLM(1,2)= 1.900000E-05,
RLM(1,3)= 4.800000E-04, 7.200000E-03, 3.300000E-04,
RLM(1,4)= 1.700000E-10,
RLM(1,5)= 2.300000E-09,
RLM(1,6)= 3.700000E-05,
RLM(1,7)= 2.700000E-06, 6.200000E-04, 3.700000E-05

```

\$END

\$RNTIME

```

FT= 10.0000      ,ITBASE=1,
PSTRNC= 0.100000E-09,
QPTRNC= 0.100000E-01,
NPSBRN=20,
CKDATA=T,
SYSFLG=T,CPLFLG=T

```

\$END

SYSTEM TREE EX 8

```

1 7 8 10
8 0 4 5
9 A 3 8
10 0 1 2 9 6 7

```

CRITICAL PAIRS TREE EX 8

```

1 4 5 5
7 1 4
5 2 1 2 3

```

S U M M A R Y I N F O R M A T I O N :

	<u>T I M E</u> (HOURS)	<u>Q S U M</u>	<u>P* S U M</u>	<u>Q S U M +</u> <u>P* S U M</u>
1	0.00000E+00	0.00000E+00	0.00000E+00	0.00000E+00
2	4.90196E-03	3.94756E-13	1.40931E-13	5.35688E-13
3	9.80392E-03	1.13060E-12	5.63726E-13	1.69433E-12
4	1.47059E-02	1.93107E-12	1.26838E-12	3.19945E-12
5	1.96078E-02	2.75180E-12	2.25490E-12	5.00671E-12
6	2.45098E-02	3.57744E-12	3.52329E-12	7.10072E-12
7	2.94118E-02	4.40427E-12	5.07353E-12	9.47780E-12
8	3.43137E-02	5.23135E-12	6.90564E-12	1.21370E-11
9	3.92157E-02	6.05848E-12	9.01961E-12	1.50781E-11
10	4.90196E-02	7.71274E-12	1.40931E-11	2.18059E-11
11	5.88235E-02	9.36701E-12	2.02941E-11	2.96611E-11
12	6.86275E-02	1.10213E-11	2.76226E-11	3.86439E-11
13	7.84314E-02	1.26755E-11	3.60785E-11	4.87540E-11

Example Problem 8 Output

14	8.82353E-02	1.43298E-11	4.56618E-11	5.99916E-11
15	9.80392E-02	1.59841E-11	5.63726E-11	7.23567E-11
16	1.07843E-01	1.76384E-11	6.82109E-11	8.58492E-11
17	1.17647E-01	1.92926E-11	8.11766E-11	1.00469E-10
18	1.37255E-01	2.26012E-11	1.10490E-10	1.33092E-10
19	1.56863E-01	2.59097E-11	1.44314E-10	1.70224E-10
20	1.76471E-01	2.92183E-11	1.82648E-10	2.11866E-10
21	1.96078E-01	3.25268E-11	2.25491E-10	2.58018E-10
22	2.15686E-01	3.58353E-11	2.72844E-10	3.08679E-10
23	2.35294E-01	3.91439E-11	3.24707E-10	3.63851E-10
24	2.54902E-01	4.24525E-11	3.81080E-10	4.23532E-10
25	2.74510E-01	4.57610E-11	4.41963E-10	4.87724E-10
26	3.13726E-01	5.23781E-11	5.77258E-10	6.29636E-10
27	3.52941E-01	5.89952E-11	7.30592E-10	7.89587E-10
28	3.92157E-01	6.56124E-11	9.01966E-10	9.67578E-10
29	4.31373E-01	7.22295E-11	1.09138E-09	1.16361E-09
30	4.70588E-01	7.88466E-11	1.29883E-09	1.37768E-09
31	5.09804E-01	8.54638E-11	1.52432E-09	1.60979E-09
32	5.49020E-01	9.20809E-11	1.76786E-09	1.85994E-09
33	5.88235E-01	9.86981E-11	2.02943E-09	2.12813E-09
34	6.66667E-01	1.11932E-10	2.60669E-09	2.71862E-09
35	7.45098E-01	1.25167E-10	3.25611E-09	3.38128E-09
36	8.23529E-01	1.38401E-10	3.97769E-09	4.11609E-09
37	9.01961E-01	1.51636E-10	4.77143E-09	4.92307E-09
38	9.80392E-01	1.64870E-10	5.63733E-09	5.80220E-09
39	1.05882E+00	1.78105E-10	6.57539E-09	6.75350E-09
40	1.13725E+00	1.91339E-10	7.58561E-09	7.77695E-09
41	1.21569E+00	2.04574E-10	8.66799E-09	8.87256E-09
42	1.37255E+00	2.31043E-10	1.10492E-08	1.12803E-08
43	1.52941E+00	2.57512E-10	1.37191E-08	1.39766E-08
44	1.68627E+00	2.83981E-10	1.66776E-08	1.69616E-08
45	1.84314E+00	3.10451E-10	1.99248E-08	2.02353E-08
46	2.00000E+00	3.36921E-10	2.34607E-08	2.37976E-08
47	2.15686E+00	3.63390E-10	2.72851E-08	2.76485E-08
48	2.31373E+00	3.89860E-10	3.13983E-08	3.17881E-08
49	2.47059E+00	4.16330E-10	3.58001E-08	3.62164E-08
50	2.78431E+00	4.69270E-10	4.54696E-08	4.59389E-08
51	3.09804E+00	5.22211E-10	5.62938E-08	5.68160E-08
52	3.41176E+00	5.75152E-10	6.82726E-08	6.88478E-08
53	3.72549E+00	6.28093E-10	8.14061E-08	8.20342E-08
54	4.03922E+00	6.81035E-10	9.56944E-08	9.63754E-08
55	4.35294E+00	7.33978E-10	1.11137E-07	1.11871E-07
56	4.66667E+00	7.86920E-10	1.27735E-07	1.28522E-07
57	4.98039E+00	8.39864E-10	1.45487E-07	1.46327E-07
58	5.60784E+00	9.45752E-10	1.84456E-07	1.85402E-07
59	6.23529E+00	1.05164E-09	2.28044E-07	2.29096E-07
60	6.86274E+00	1.15753E-09	2.76252E-07	2.77409E-07

Example Problem 8 Output

61	7.49020E+00	1.26343E-09	3.29078E-07	3.30342E-07
62	8.11765E+00	1.36932E-09	3.86525E-07	3.87894E-07
63	8.74510E+00	1.47522E-09	4.48590E-07	4.50066E-07
64	9.37255E+00	1.58112E-09	5.15276E-07	5.16857E-07
65	1.00000E+01	1.68702E-09	5.86581E-07	5.88268E-07

K AFTER EXACTLY K STAGES HAVE FAILED BY 1.00000E+01
 STAGE HOURS, PORTION OF THE UNRELIABILITY CAUSED BY:
 FAILURES

	FAULT HANDLING	EXHAUSTION OF MODULES
	-----	-----
0	1.68702E-09	0.00000E+00
1	X	5.86579E-07
2	X	1.73617E-12
3	X	1.19367E-19

TOTAL SYSTEM UNRELIABILITY AT 1.00000E+01 HOURS = 5.88268E-07

Appendix B

CARE III Variables

The user-friendly interface creates the input file to be used when running CARE III. The input file could be created manually with an editor, but typically this results in syntactically incorrect CARE III input files. Also, some CARE III variable names are cryptic, and the actual parameters or values they represent are not easily interpreted.

Though the entire creation of the input file by hand is not recommended, there are times when editing a file already created by the UFI may be necessary. Therefore, a description of each of the variables found in the CARE III input files is given. Included parenthetically with most descriptions are the CARE3MENU screen (in uppercase letters) and line (in boldface letters) from which the data values are obtained. The variables that the typical user will most likely be altering in an editing session have been marked with double asterisks. For a more thorough description of the variables, see reference 2.

FLTTY P Paragraph

- LGTMST This flag indicates the choice of "logarithmic" (nonlinear) time steps (LGTMST = T) or linear time steps (LGTMST = F). (RUNTIME CONTROL OPTIONS INPUT: **Integration steps** ($17 \leq \text{NSTEPS} \leq 64$, or "**Logarithmic**")):
- **NFTYPS This variable indicates the total number of fault handling models defined for the model. For example, in example problem 7, three fault types are described: (NONE), PERMANENT B, and PERMANENT C.
- **ALP These are the values for α entered for each fault handling model. With this and all other fault handling model parameters, the first value in the line is associated with the first FHM entered, the second value is associated with the second FHM entered, etc. (FAULT HANDLING MODELS: **Alpha**)
- **BET This variable indicates the β values for each of the fault handling models. Note that though all β values may be identical, each value is represented. (FAULT HANDLING MODELS: **Beta**)
- **DEL The $\delta(t')$ values for each of the fault handling models are included in this line. (FAULT HANDLING MODELS: **Delta**)
- **RHO RHO enumerates the $\rho(t')$ values for each of the fault handling models. (FAULT HANDLING MODELS: **Rho**)
- **EPS This variable indicates $\varepsilon(\tau)$ values for each of the fault handling models. (FAULT HANDLING MODELS: **Epsilon**)
- IDELF The user can choose either the uniform or exponential distribution to describe $\delta(t')$. If the exponential distribution is chosen, IDELF = 1. If the uniform distribution is chosen, IDELF = 2. (FAULT HANDLING MODELS: **Delta FHM**)
- IRHOF This flag indicates the distribution chosen to describe $\rho(t')$. As in IDELF above, IRHOF = 1 indicates the exponential rate function and IRHOF = 2 indicates the uniform rate function. (FAULT HANDLING MODELS: **Rho FHM**)
- IEPSF This flag indicates the distribution chosen to describe $\varepsilon(\tau)$. IEPSF = 1 indicates that the exponential distribution is chosen, and IEPSF = 2 indicates that the uniform distribution is chosen. (FAULT HANDLING MODELS: **Epsilon FHM**)

- MARKOV Typically, this variable is set equal to one. If all distributions for $\delta(t')$, $\rho(t')$, and $\varepsilon(\tau)$ are exponential, MARKOV = 1 acts as a flag to CARE III and a very efficient homogeneous Markov solution technique is used to solve the problem. If any or all of the distributions are uniform, CARE3MENU sets MARKOV = 2, and a nonhomogeneous Markov solver is used to find the solution. A more in-depth discussion can be found in the CARE III User's Guide (ref. 2).
- **PA This indicates the value of P_A for each of the fault handling models. (FAULT HANDLING MODELS: **Pa**)
- **PB This variable indicates the value of P_B for each of the fault handling models. (FAULT HANDLING MODELS: **Pb**)
- **C This variable indicates the value of C for each of the fault handling models. (FAULT HANDLING MODELS: **C**)

See figure 6.3 for the pictorial representation of the parameters ALP, BET, DEL, RHO, EPS, PA, PB, and C.

- CVPRNT CVPRNT is a flag for outputting moments of the single- and double-fault handling functions. The data generated by CVPRNT = T are used by the program developers and are not normally of interest to the reliability analyst.
- CVPLOT This variable is a flag for plots of the single- and double-fault handling functions. For interested users, a detailed description of this variable can be found in the CARE III User's Guide (ref. 2). (OUTPUT CONTROL OPTIONS INPUT: **Coverage Functions Plot (T or F)**)
- IAXSCV This parameter describes the Y-axis scale to be used when the functions described in CVPLOT are plotted. (OUTPUT CONTROL OPTIONS INPUT: **Coverage Y-Axis Selection...**)

STAGES Paragraph

- **NSTGES Indicates the total number of stages defined in the model.
- **N These values represent the number of modules in each stage. In example problem 7, stages 1, 2, and 4 each have three modules, and stages 3 and 5 each have four modules. (STAGE DESCRIPTION INPUT: **Number of Beginning Modules in Stage**)
- **M These numbers indicate the minimum number of modules needed for stage function. (STAGE DESCRIPTION INPUT: **Minimum Number of Modules for Stage Operation**)
- **NSUB The values for this variable indicate the number of redundant submodules there are for each of the modules in the stage. For a module with no internal redundancy, NSUB = 0. (STAGE DESCRIPTION INPUT: **Number of Beginning Submodules per Module**)
- **MSUB These numbers represent the minimum number of submodules needed per module (in the corresponding stage) for module operation. (STAGE DESCRIPTION INPUT: **Minimum Number of Submodules for Module Operation**)

- ACSP The variable name stands for active spares? If ACSP = T, all NSUB sub-modules are active (including the NSUB-MSUB “spares”) and can fail at the rate given by RLMSUB. If ACSP = F, only MSUB submodules are active and subject to failure. As active submodules fail at rate RLMSUB, they are replaced from the NSUB-MSUB spare pool until less than MSUB submodules are nonfailed. At that point, the module falls below minimum operational requirements and is considered failed. (STAGE DESCRIPTION INPUT: **Spare Submodules On-Line (T/F)**)
- LC The LC variable affects the CARE III “QSUM” output value by inhibiting the computation of some critical pair failure paths. (STAGE DESCRIPTION INPUT: **Critical Fault Threshold**)
- **NOP The NOP value specifies which modules are in use and which are spares. It also specifies which modules are subject to critical pair failures. If no NOP values are indicated in the input file, CARE III assumes that all modules are in use. The CARE III User’s Guide (ref. 2) provides an in-depth discussion of the NOP parameter. (STAGE DESCRIPTION INPUT: **Set(s) of Modules Subject to Critical Pair Failures**)
- **IRLPCD This variable specifies the option chosen for output printout. The IRLPCD values and their associated output are as follows:
 1—summary results only
 2— $P(t|l)$, probability of successful operation plus summary results
 3— $Q(t|l)$, probability of a fault handling failure (single-point or critical pair failure) plus summary results
 4—all the above
 The user is cautioned about selecting options 2 to 4 when a large system is being modeled. The amount of output can be large. (OUTPUT CONTROL OPTIONS INPUT: **Output Option (1-4)**)
- RLPLOT This is a flag specifying if summary information QSUM, P*SUM, and QSUM + P*SUM is to be plotted against time. (OUTPUT CONTROL OPTIONS INPUT: **Reliability Functions Plot (T or F)**)
- IAXSRL This parameter describes the Y-axis scale to be used when the summary information described in RLPLOT is plotted. (OUTPUT CONTROL OPTIONS INPUT: **Reliability Y-Axis Selection...**)
- FLTCAT Paragraph*
- **NFCATS This variable indicates the number of fault handling models associated with each stage.
- **JTYP JTYP associates the appropriate fault handling model(s) with the stages. In general, JTYP (i, x) = F indicates that the fault type associated with stage x is F . Note that because each stage can have up to five different fault handling models associated with it, the variable i has a range of one to five. (FAULT OCCURRENCE MODELS: **Fault Type**)
- **OMG This is shape parameter omega (ω) of the Weibull fault occurrence rate $\lambda\omega(\lambda t)^{\omega-1}$. OMG (i, x) = w states that the i th fault type associated with stage x has an omega value equal to w . (FAULT OCCURRENCE MODELS: **Omega**)
- **RLM RLM is the parameter lambda (λ) of the Weibull fault occurrence rate. RLM (i, x) = L states that the i th fault type associated with stage x has a lambda value equal to L . (FAULT OCCURRENCE MODELS: **Lambda**)

- **JSBTYP** JSBTYP associates the appropriate fault handling model(s) with the redundant submodules in a stage. For a stage with internal redundancy, JSBTYP must always associate a permanent fault type ($\alpha = 0$) to the redundant portion of the module. Note that for stage x , with internally redundant modules, the original fault type parameter JTYP defines the fault type(s) for stage x that affect either the nonredundant portion of the module or the redundant portion when no redundant submodules remain. (FAULT OCCURRENCE MODELS—second column: **Fault Type**)
- **OMGSUB** For a stage with internal redundancy, OMGSUB represents the omega (ω) parameter of the Weibull fault occurrence rate $\lambda\omega(\lambda t)^{\omega-1}$ for the redundant portion of the modules. Note that for stage x , with internally redundant modules, the original ω parameter OMG characterizes the failure rate of either the nonredundant portion of the module or the redundant portion when no redundant submodules remain. (FAULT OCCURRENCE MODELS—second column: **Omega**)
- **RLMSUB** For a stage with internal redundancy, RLMSUB represents the lambda (λ) parameter of the Weibull fault occurrence rate for the redundant portion of the modules. Note that for stage x , with internally redundant modules, the original λ parameter RLM characterizes the failure rate of either the nonredundant portion of the module or the redundant portion when no redundant submodules remain. (FAULT OCCURRENCE MODELS—second column: **Lambda**)

RTIME Paragraph

- **FT** This variable indicates flight time. (RUNTIME CONTROL OPTIONS INPUT: **Mission Time**)
- ITBASE** ITBASE specifies the time base used for the system operating time. Shown below are the five user choices for the mission time base and the corresponding value of ITBASE:

Hours	1
Minutes	2
Seconds	3
Days	4
Years	5

(RUNTIME CONTROL OPTIONS INPUT: **Timebase...**)

- SYSFLG** This is a flag used by CARE III to indicate whether or not a system tree is included in the input file. SYSFLG = T indicates that a system tree is to follow, and SYSFLG = F indicates that no tree follows.
- **CPLFLG** This flag indicates whether or not the input file contains a critical pair tree. CPLFLG = T indicates the presence of a critical pair tree; CPLFLG = F indicates no critical pair tree is to follow.
- PSTRNC** For most users, the default value of PSTRNC (PSTAR TRUNCATOR) is adequate. This parameter is used to limit the number of terms used in computing the fault handling unreliability QSUM. (RUNTIME CONTROL OPTIONS INPUT: **Cut Truncation Value**)
- QPTRNC** As in PSTRNC, QPTRNC is usually set equal to its default. As a control parameter, it limits the number of terms used to compute the fault handling unreliability QSUM. (RUNTIME CONTROL OPTIONS INPUT: **QPTRNC Value**)

- **NPSBRN** This parameter determines the maximum number of stages placed in each subrun (number per subrun). The User's Guide (ref. 2) provides some insight into the varying of this parameter. (RUNTIME CONTROL OPTIONS INPUT: **NPSBRN Value**)
- CKDATA** This flag indicates that the CARE III program is to check the input file values before computing system unreliability. CKDATA = T indicates "check the data," and CKDATA = F indicates "don't check the data." The variable is typically set equal to T (true). (RUNTIME CONTROL OPTIONS INPUT: **CKDATA (T or F)**)

The Tree Paragraphs

These paragraphs are exactly the CARE3MENU inputs minus the "END" inputs which indicate the end of inputs for the CARE3MENU program. The first line corresponds to the **System Tree Label** input; the next line is the range to the CARE3MENU request for the **Input Event ID Range, Output Gate ID Range**; and the next line(s) are the **System Tree Logic Block**.

The last lines of the input file are the critical pair tree description, if a critical pair tree exists for the problem. The first line of the **Critical Pairs Fault Tree Input** section is the **Fault Tree Label**, followed by the **Module and Logic Range ID** line. The next line(s) indicate the **Module Unit to Stage Association**, and the last line(s) describe the critical pair tree **Logic Gate ID**. For input files with no critical pair tree(s), the last lines of the input file are the system tree paragraph.¹

Most input file lines are written in an abbreviated format. For example, the line describing the number of beginning modules in each stage for example problem 7 reads **N = 3, 3, 4, 3, 4**, but could have been written **N(1) = 3, N(2) = 3, N(3) = 4, N(4) = 3, N(5) = 4**, which is the form shown in the User's Guide (ref. 2). The forms are equivalent and either form is correct.

Notice that data are separated by commas. This is very important. The spacing shown, however, is simply a function of the FORTRAN FORMAT statements used by the CARE3MENU to write the input file and does not need to be observed when editing input files. The file is written entirely in uppercase letters, and when editing the file, use uppercase letters.

Be especially careful when adding or deleting stages, fault handling models, or fault occurrence models. Several variables may need to be changed. For example, if a transient fault were added to an input file and attached to stage 1, at least 13 variables would need to be changed. (The obvious changes would be to ALP, BET, DEL, RHO, EPS, IDELF, IRHOF, IEPSF, PA, PB, and C. But what about the number of fault types (NFTYPS)? It would need to be changed (incremented by one). JTYP(1,1) would also have to be altered to reflect the new fault type associated with stage 1, and OMG and RLM may also need to be changed.) Major changes would typically be performed by ALTERING a file with the CARE3MENU program.

¹ CARE III does not require a system tree block in the input file. In the case of no user-specified system tree, a "default" tree is assumed. This default tree consists of one OR gate with all stages as input and implies that a failure in any stage will cause system failure. To specify the default system tree while using CARE3MENU, simply type DEFAULT when the system requests **Enter System Tree Label**.

Appendix C

Executing CARE III Using a VAX/VMS System

Typically, the user-friendly interface files are in a directory separate from the CARE III files. It is most advantageous to be in the CARE III directory when executing the program. RUNCARE.COM is the VMS operating system command file which executes the three CARE III modules and combines their outputs into one output file entitled <filename>.OUT. Directions for executing CARE III are provided as comment statements in the RUNCARE.COM file and can be read by printing or copying the file to the screen.

Once again, user input is underlined and characters that are not underlined indicate useful information from the instructor. The steps necessary to execute CARE III are as follows:

- Step 1—Get to the CARE III directory; type SET DEFAULT <directory>.
- Step 2—Copy the input file from the CARE3MENU directory to the CARE III directory; type COPY[<directory >] <filename.ext > *. (The asterisk indicates that the copy destination is the default. If the user is in the CARE III directory, that is the default.) For example, type COPY[< root directory > . CUF1] EX1.DAT*.
- Step 3—Execute CARE III; type @RUNCARE <filename.ext>. For example, to execute CARE III with the input file entitled EX1.DAT, type @RUNCARE EX1.DAT.
- Step 4—CARE III will usually take between 20 seconds and 4 or 5 minutes to execute. During this time many system error statements may be printed to the screen and can be ignored. When the dollar sign prompt reappears, the command file has finished executing CARE III and the output file <filename>.OUT has been created.

Directions for executing CARE III on other systems (such as the UNIX operating system or CYBER NOS operating system) are not included. The CARE3MENU was developed on the Digital Equipment Corporation VAX computer with the VMS operating system and uses several routines from the VMS Runtime Library and the VMS System Services. It is therefore assumed that users who are reading this manual and using the CARE3MENU have a VAX/VMS system.

To execute the CARE3MENU program, simply type @CARE3MENU after setting the directory default to the appropriate directory. The input file created by CARE3MENU, unless otherwise specified by the file name, is placed in the same directory as CARE3MENU.EXE resides.

~~END~~

~~DATE~~

~~JAN. 12, 1987~~

C-2

11. References

1. Bavuso, Salvatore J.: A User's View of CARE III. *1984 Proceedings Annual Reliability and Maintainability Symposium*, Inst. of Electrical and Electronic Engineers, Inc., c.1984, pp. 382-389.
2. Bavuso, S. J.; and Petersen, P. L.: *CARE III Model Overview and User's Guide (First Revision)*. NASA TM-86404, 1985.
3. Rose, D. M.; Altschul, R. E.; Manke, J. W.; and Nelson, D. L.: *Review and Verification of CARE III Mathematical Model and Code: Interim Report*. NASA CR-166096, 1983.
4. Trivedi, Kishor S.; and Geist, Robert M.: *A Tutorial on the CARE III Approach to Reliability Modeling*. NASA CR-3488, 1981.
5. Martensen, A. L.: *CARE III User Friendly Interface User's Guide*. NASA CR-178251, 1987.
6. Bryant, L. A.; and Stiffler, J. J.: *CARE III, Version 4 Enhancements*. NASA CR-177963, 1985.



Report Documentation Page

1. Report No. NASA TM-4011	2. Government Accession No.	3. Recipient's Catalog No.	
4. Title and Subtitle Tutorial and Hands-On Demonstration of a Fluent Interpreter for CARE III		5. Report Date November 1987	6. Performing Organization Code
		8. Performing Organization Report No. L-16319	
7. Author(s) Anna L. Martensen and Salvatore J. Bavuso		10. Work Unit No. 505-66-21-02	11. Contract or Grant No.
9. Performing Organization Name and Address NASA Langley Research Center Hampton, VA 23665-5225		13. Type of Report and Period Covered Technical Memorandum	
		14. Sponsoring Agency Code	
12. Sponsoring Agency Name and Address National Aeronautics and Space Administration Washington, DC 20546-0001		10. Work Unit No. 505-66-21-02	
15. Supplementary Notes Anna L. Martensen: PRC Kentron, Inc., Hampton, Virginia. Salvatore J. Bavuso: Langley Research Center, Hampton, Virginia. (This report supersedes NASA TM-85811 entitled "CARE III Hands-On Demonstration and Tutorial," May 1984.)			
16. Abstract <p>This document updates a document originally written as part of a workshop on the CARE III capability held at NASA Langley Research Center on February 22 to 24, 1984. Subsequent to the workshop, CARE III and its interface program were enhanced, and extensive changes to the original document became necessary. This document, like its predecessor, is designed to illustrate the user interface capability and the salient CARE III features by describing various examples of reliability models and their solutions through the use of CARE III.</p>			
17. Key Words (Suggested by Authors(s)) CARE III Reliability Fault tolerance User-friendly interface CARE III menu		18. Distribution Statement Unclassified—Unlimited Subject Category 61	
19. Security Classif.(of this report) Unclassified	20. Security Classif.(of this page) Unclassified	21. No. of Pages 100	22. Price A05