

ELECTROCHEMICAL PROCESSING OF SOLID WASTE

PREPARED BY

J.O'M. BOCKRIS
G.D. HITCHENS
L.KABA

LABORATORY FOR SURFACE ELECTROCHEMISTRY
DEPARTMENT OF CHEMISTRY
TEXAS A&M UNIVERSITY

ANNUAL REPORT
FEBRUARY 1988

TECHNICAL MONITOR: CINDA CHULLEN

SUBMITTED TO:

CREW & THERMAL SYSTEMS
NASA JOHNSON SPACE CENTER
HOUSTON, TEXAS 77058

NASA GRANT - 1987 NAG - 192

CONTENTS

SUMMARY

ANTICIPATED BENEFITS TO CLOSED LIFE SUPPORT SYSTEMS

1. INTRODUCTION
2. SCIENTIFIC BACKGROUND
 - 2.1 Solid Waste Electrolysis
 - 2.2 Biomass Electrolysis
 - 2.3 Urine Electrolysis
 - 2.4 Coal Electrolysis
3. RESULTS
 - 3.1 Efficiency of CO₂ Recovery from Fecal Waste
 - Rationale
 - Apparatus
 - Artificial Fecal Waste Preparation
 - Potential Sweep Measurements
 - Constant Potential Electrolysis
 - Constant Current Electrolysis
 - 3.2 Packed-Column Lead Dioxide Electrolyzer
 - Rationale
 - Methods and Apparatus
 - Phenol Oxidation
 - Oleic Acid Oxidation
4. CONCLUSIONS AND RECOMMENDATIONS
5. REFERENCES
6. TABLES AND FIGURES

SUMMARY

The report describes the investigation into electrolysis as a means of waste treatment and recycling on manned space missions. The work was sponsored by Crew and Thermal Systems, Johnson Space Center, Houston, Texas.

1. The electrochemical reactions of an artificial fecal waste mixture has been examined.

2. Waste electrolysis experiments have been performed in a single compartment reactor, on platinum electrodes, to determine conditions likely to maximize the efficiency of oxidation of fecal waste material to CO₂.

3. The maximum current efficiencies for artificial fecal waste electrolysis to CO₂ to be around 50% in this test apparatus.

4. Experiments involving fecal waste oxidation on platinum indicates that electrodes with a higher overvoltage for oxygen evolution such as lead dioxide will give a larger effective potential range for organic oxidation reactions.

5. An electrochemical packed column reactor has been constructed with lead dioxide as electrode material.

6. Preliminary experiments have been performed using a packed-bed reactor and continuous flow techniques showing this system may be effective in complete oxidation of fecal material.

7. The addition of redox mediator Ce³⁺/Ce⁴⁺ enhances the oxidation process of biomass components.

8. Scientific literature relevant to biomass and fecal waste electrolysis have been reviewed.

Anticipated Benefits to CELSS

- (1) Waste treatment/management processes are required for manned space exploration. The successful development of solid waste electrolysis will provide technology for waste handling/disposal on manned space missions.
- (2) This waste treatment process will form the basis for recycling of waste. The process will provide CO₂ a basic nutrient for plant photosynthesis as well as providing CO₂ for oxygen regeneration by the Bosch or Sabatier processes.
- (3) The electrical energy consumed in the electrolysis can be recovered. Hydrogen is produced during the reaction in large quantities and can thus be utilized to regenerate electricity in a conventional oxygen/hydrogen fuel cell.
- (4) The electrolysis may be performed at different potentials depending upon the type of waste, thus a good deal of control may be exerted on the breakdown process. This offers the possibility of minimizing side reactions leading to the complete recovery of the organic carbon as either CO₂ or low molecular weight carbon compounds for further recycling.
- (5) The technique represents a means of oxidizing organic waste without the consumption of atmospheric oxygen thus does not diminish the available oxygen supply.
- (6) High temperatures are not required in this process (maximum temperature around 100°C).
- (7) The technology may be used for all types of organic waste including human waste but may be extended to inedible plant biomass and plastic food packages made of biodegradable polymers etc.

1.

INTRODUCTION

The aim of this project is to degrade organic waste materials, mostly fecal waste, to CO_2 by oxidizing the waste in the anodic compartment of an electrochemical cell. The cathodic compartment will contain a strong acid and hydrogen will be evolved. The process is illustrated schematically in Figure 1.

In general terms, the overall reactions will take the following form:

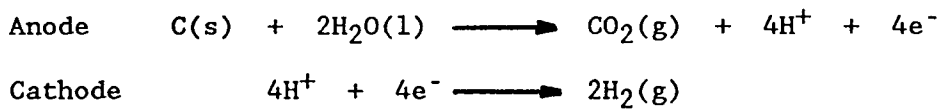

It should be stressed that the bulk of the carbon undergoing oxidation will not be in its elemental state. Moreover, these reactions simulate the overall reactions and do not go into specific detail. It is indeed likely that there will be products of the oxidation other than those implied by the above formula especially since much of the waste material will be in the form of complex biological polymers derived from undigested food and microorganisms of the intestinal flora.

During biomass electrolysis, hydrogen will be evolved continuously from the cathodic compartment. It is likely, that hydrogen can be obtained in this manner at lower cell potentials than the reversible potential (ie 1.23) for the electrolysis of water. Indeed hydrogen can be obtained at potentials in the region of 0.8V using lignite slurry as anodic depolarizer. Thus, the supply of hydrogen, which can be used to generate electricity in efficient hydrogen/oxygen fuel cells, will off-set considerably the energy consumed in the electrolysis.

An important feature of this technique is that the potential at which the electrolysis is occurring can be selected such that particular reactions can be enhanced. Since the type of waste to be degraded is likely to vary considerably during a mission, a flexible system can be adopted to provide the optimal potential for the degradation of the particular type of waste available. In addition, these reactions will be enhanced by the use of elevated temperatures (ie up to 100°C. Even so, in comparison with incineration for example, electrolysis is a low temperature waste treatment method which possibly can be more easily engineered into a small space vehicle than higher temperature devices.

The technology being developed in this report is aimed at investigating a waste treatment method for all types of solid organic waste that are likely to accumulate in a space environment during a manned mission. Inedible material from higher plant components of a regenerative life support system could constitute a major source of waste in the future; the electrolysis of plant biomass is an established research area. Furthermore, plastics (used in food packaging etc.) based on biodegradable polymers such as cellulose, may be treated in this way.

It is worthwhile discussing what processes would utilize the CO₂ in a regenerative system since, these components would have to be integrated with the electrolysis system. Photosynthetic systems can be used to fix CO₂ and thereby act as a potential food source, however, the growth of higher plants (or photosynthetic microorganisms) in microgravity may not be feasible for some time. An alternative system exists which involves the regeneration of oxygen from CO₂, for crew cabin resupply, by the Bosch reaction. Devices based on this principle are being fabricated at the present time for use in

life support systems (1,2).

For deep space manned missions, where resupply becomes impractical, the recycling of nutrients will be a primary concern. The research approach described in this report has evolved to investigate the efficiency of recycling nutrients for regenerative life support systems. An important consideration of this work is how to maximize the amount of material that can be recovered as reuseable compounds by this method through attaining conditions to maximize the oxidation of waste materials to CO₂ (ie to effect "electrochemical incineration"). Important previous work on electrochemical treatment of biomass related to this project is reviewed below.

2.

SCIENTIFIC BACKGROUND

2.1 Fecal Waste Electrolysis

Electrolytic breakdown of human waste has been performed previously in one study (3). These workers were interested in upgrading fecal waste and urine to provide a nutrient growth medium for algae and higher plants as a source of food in closed life support systems. In preliminary studies, these workers noted that more effective electrolysis could be achieved using pretreatment methods to solubilize the suspended fecal matter (this point has been emphasized in the approach proposed by the present authors). In a study of various methods to solubilize/digest fecal matter Tischer and colleagues (4) showed that hypochlorous acid was the best agent to use and could turn fecal waste into a colorless and odorless mixture within minutes. The important point here, as was noted by these workers, is that hypochlorite can easily be obtained by the electrolysis of urine due to its high chloride content (also see 5). Thus, it seems that possible oxidizing agents for fecal waste degradation can in fact be easily generated using on-board urine electrolysis.

The experiments performed by Tischer and colleagues, which involved the electrolysis of both urine and feces mixed together, were successfully performed in a simple reaction cell using platinum working electrodes; procedures for the control of the electrode potential during the reaction appear to have been minimal. In a series of experiments they showed that fecal matter could be decolorized and clarified in less than 24 hours using a current of 50 mA/cm²; furthermore, the odor was lost after 1.5 hours of the electrolysis. No quantitative estimates of the products were available

however, CO_2 , NH_3 , O_2 and Cl_2 were evolved. No information is available concerning the production of ClO^- and ClO_2^- ClO_3^- during the reaction, however, electrolysis experiments in which additional chloride was added indicated that the time required for electrolysis could be decreased by a factor of 3 or more.

2.2 Biomass Electrolysis

Considerable research has been conducted into the electrolysis of biomass that has originated from plant material. In this section, aspects of the electrochemistry of biopolymers (ie polysaccharides) will be reviewed since a significant proportion of fecal biomass will be constituted by this type of material.

A number of older studies are worthy of comment beginning with Oertel (6) who showed that cellulose dissolved in 16% potassium chloride can be degraded into lower molecular weight entities. By varying electrolyte concentration, current density and time, gel gums with adhesive properties could be obtained. Cellulose electrolysis in 0.5 M H_2SO_4 saturated with $[(\text{NH}_4)_2\text{SO}_4]$ also led to considerable degradation of cellulose (7). Hemicelluloses have been degraded in 5M NaOH (2% wt/wt) to CO_2 and H_2O and at the cathode, pure hydrogen was evolved (8). Neuberg (9) has investigated the electrolysis of 60 organic compounds including starch, mannitol and raffinose and found that after many days of electrolysis, the polymers were fragmented into their constituent sugars. The production of hydrogen by glucose-depolarized water electrolysis has been proposed using Pb-Ru anode leading to glucose oxidation at less anodic potentials (10).

Of particular relevance to the present work is the investigation performed by Bockris et al concerning the possibility of utilizing plant waste materials based on polysaccharides as oxidants in fuel cell systems (11). Initially, simple carbohydrates were investigated such as sucrose, cellobiose (β .D-glucose dimer) and glucose. The electrolysis was performed in 40% $H_3PO_4/5N NaOH$ at temperatures 80-100°C. A platinized platinum gauze (52 cm²) was used as the anode. It was found that the reactivity decreased for molecules of increasing complexity. Nevertheless, it was found that cellulose can be broken down to CO_2 with a current efficiency of around 100% and that 2 faradays were involved in the evolution of 1 mol of CO_2 .

The following stoichiometric equation for the reaction was suggested; the monomer glucose is shown for simplicity.

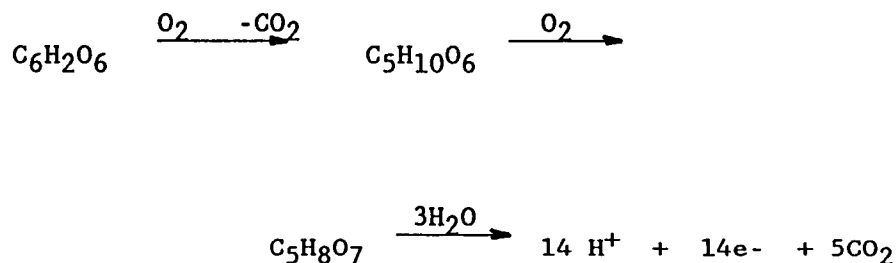

In this scheme, 2.3 Faradays would be used per mole of CO_2 evolved, which agrees with experimental results. These workers drew attention to this concept as a possible means of waste management for space vehicles.

2.3 Urine Electrolysis

Numerous studies of urine electrolysis have been made in the area of biomedicine (12,13,14) and an extensive study has been made by Lockheed on electrochemical urine pretreatment for use on manned space flights (5). The Lockheed study showed that urine electrolysis using 10%-Rh Pt working electrodes could result in TOC (Total Organic Carbon) and TKN (Total Kjeldahl Nitrogen) conversion to CO_2 and N_2 . Studies of the reaction mechanism showed that hypochlorite generated during the electrochemical reaction was responsible for the oxidation of urea. This was confirmed in electrolysis experiments using an artificial urine mixture where the chloride salts were replaced by sulphates. Under these conditions, the oxidation of urea was severely inhibited; furthermore, the addition of hypochlorite solution to urine was a highly effective means of eliminating TKN and TOC from the sample. However, there was a major draw-back to this process in that, under the conditions used, perchlorates built up to high levels during the course of the reaction and despite several treatments such as UV irradiation, the perchlorate levels could not be significantly reduced. It should be noted that all the experiments performed, high potentials were used (ie above 2.2V vs Ag/AgCl) which are favorable for the generation of hypochlorite and are not likely to cause the direct decomposition of urea to N_2 and CO_2 which occurs at its maximum rate at lower potentials (ie +1.6V vs Ag/AgCl).

Urine (urea) electrolysis is an important area in biomedicine and ultimately offers a practical alternative to dialysis for the treatment of renal failure . Electrochemical systems have been devised for the selective decomposition of urea from body fluids and the work of Yao and colleagues is particularly noteworthy (13,14,15). These workers concentrate on urea

electrolysis at lower potentials using a technique intermittently alternating between two platinum black electrodes as working and counter electrodes to periodically regenerate the electrodes. Electrolysis at +0.8 verses Ag/AgCl is highly effective at decomposing urea but at the same time, none of the likely toxins (OCl^- NO_3^- NO_2^- CN^- and NH^+) are formed. The only apparent products are CO_2 N_2 and H_2O .

2.4 Coal Electrolysis

The technology associated with the electrolysis of coal is relevant to the present project. Coal is a complex and insoluble polymer that is in some ways similar to the types of waste material that are the subject of this report, therefore, studies of coal electrolysis represent a guide to biomass electrolysis.

Coal electrolysis represents a means of obtaining hydrocarbon fuels and hydrogen (15,16,17,18). The technique usually involves placing a coal slurry in the anodic compartment of an electrochemical cell (15). During the electrolysis the coal is oxidized to organic compounds in solution some of which are of potential value as fuels (15,16). In addition, hydrogen is evolved from the cathode (17). Initial work on lignite slurry showed that the evolution of hydrogen occurred at potentials about 60% lower than those normally required for water electrolysis and that no oxygen evolution was observed (17). These workers paid little attention to the anodic products. Subsequent work has shown that the high oxidation currents were due to the oxidation of dissolved Fe^{2+} (19). Furthermore Park (20,21), discovered a secondary reaction, the oxidation of coal particles by Fe^{3+} in solution; the Fe^{3+} produced in the reaction was subsequently reoxidized to Fe^{3+} at the

electrode surface. Recent work by Taylor et al has provided further information concerning the use of redox couples to mediate the oxidation of coal slurry (22).

Work performed in this laboratory showed that hydrocarbons (C₁₈-C₁₉) are formed in the anodic compartment during oxidation after the electrolysis had been performed for 5 hours (15). Platinum electrodes were used and the lignite was present at a concentration of 0.6g/ml and electrolyzed in 5M sulfuric acid.

Current/potential measurements were performed to determine the potentials for the maximum oxidation rate of the coal prolonged electrolysis was then performed at these potentials. An assessment of the reaction taking place are likely to include the Kolbe reaction given below.

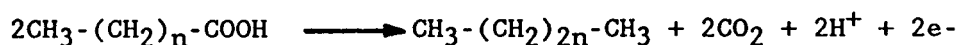

This reaction involves the dimerization of 2 organic molecules and gives rise to CO₂. The reversible potential for the Kolbe reaction for acetic acid/acetate is -0.40 V but at higher temperatures reduction in the overpotential may occur (11).

However, after prolonged electrolysis of several days, no compounds were detected in solution having been oxidized to CO₂ (15).

Major research areas concerning coal electrolysis are (a) methods to improve solubility of coal and, (b) the use of redox mediators to enhance the oxidation process in solution.

3.

RESULTS

3.1 Efficiency of CO₂ Recovery From a Fecal Waste

Rationale

A series of experiments have been performed to assess the conditions necessary to effect the electrochemical oxidation of waste biomass. The composition of fecal biomass can vary greatly, thus, will give rise to difficulties in reproducing and interpreting the results. Consequently, a mixture of chemicals and microorganisms has been devised that mimics the composition and consistency of the naturally occurring material. A large amount of this material can be made up and used in these experiments in the knowledge that each batch will have reproducible chemical properties.

The research strategy has been to generate information on the best conditions and treatments to effect the complete oxidation of the material. Thus, a series of comparison studies have been made under different conditions temperature and cell voltage. Of the products of the reaction, only CO₂ has been measured since it provides direct information of the extent of the oxidation process. Evaluation of the various conditions in terms of maximizing the waste oxidation has been made by estimating the current efficiency for the breakdown.

Apparatus

These experiments have been performed in single compartment reactor made of glass schematically shown in Figure 2. Both the working and counter electrodes are of platinum sealed in glass and fitted through the top of the

cell in ground glass joints. The area of the working electrode was 26 cm². A saturated calomel electrode was used as reference. The cell was continuously supplied with nitrogen as a means of sparging the CO₂ from the electrolyte and additional stirring was by a magnetic follower. The outlet gas was carried through a tube packed with glass wool and then to a water trap and finally to a barium hydroxide solution. The CO₂ produced was determined by back titration with a standardized quantity of HCl. Parallel experiments were sometimes performed on the GC to confirm the accuracy of the barium hydroxide analysis. Temperature could be raised by placing the reaction cell on a hot plate. A modified Pine Instrument RDE4 potentiostat was used for voltage sweep experiments and for galvanostatic and potentiostatic electrolysis.

Artificial Fecal Waste Preparation

The mixture was made up entirely from material from the Sigma Chemical Company. Dried Escherichia coli and Torpuлина was used to mimic the microbial content of fecal waste since these items can be purchased in the large quantities needed at reasonable cost. Cellulose was used to represent the indigestible material of fecal waste and oleic acid was present to represent the fat material. The remainder was made up of protein and inorganic material. The exact content of the mixture is given in Table 1; a 4.6 kg mixture was made and was sufficient for all of the fecal waste experiments. The mixture had a paste-like consistency and gave off a strong odor probably due to the microbes present. Between the experiments the mixture was kept frozen. For the experiments described below, the minimum of pretreatment was given. The material was weighed then given a 5 minute homogenization with a pestle and mortar in H₂SO₄ then added to the reaction vessel containing the electrolyte.

Potential Sweep Measurements

Figure 3 shows potential sweep measurements performed on the artificial fecal waste mixture to determine appropriate potentials for the oxidation of this type of material and obtain estimates of the limiting current for these oxidations for use in interpreting electrolysis experiments performed later. The total reaction volume was 250 ml and the electrolyte consisted of 5M H₂SO₄ the reaction temperature was 25°C. The experiments were performed using increasing concentrations of the waste mixture up to a final concentration of 4.8 g/liter (corresponding to a dry weight of 1.87g/liter) the sweep rate was 50 mV/sec. The oxidation of the organic material occurs at potential range between 1.4 and 1.8 V (versus NHE); the oxygen evolution reaction occurs above this potential range.

Values of limiting current for each of the concentrations used were plotted (Figure 4); from this graph limiting currents for the concentrations used in constant potential electrolysis experiments could be obtained. Similarly, the effect of temperature on the limiting current for a single concentration of waste has been established (see Figure 5). Since some later electrolysis experiments were performed at 80°C, the effect of temperature on the limiting current can be taken into account.

The results on the concentration-dependence of the reaction have been used to estimate the total amount of dissolved organic material at the start of the electrolysis using the following equation:

$$I_L = 0.02 n C$$

Where I_L is the limiting current, n is the number of electron taking part in the reaction and C is the concentration of organic material. The organic material is of a complex nature and its molar concentration cannot be determined but has been estimated assuming oleic acid (C_{18}) to be a typical molecular species of the waste material (MW 282) and that 102 electrons are involved in its oxidation to CO_2 . By this method, the amount of dissolved material, at the beginning of the electrolysis, was estimated to be 3% of the total amount of organic material added to the electrolyte.

Constant Potential Electrolysis

Electrolysis was performed at 5 potentials 1.4, 1.5, 1.6, 1.7 and 1.8 V (versus NHE). These potentials were chosen since they lie in the region where the oxidation of organics was observed on the potential sweep measurements. These electrolysis experiments were performed at 80°C over a period of an hour during which the amount of CO_2 evolved was measured. The final concentration of waste was 12.0 g/liter (4.68 g dry weight/liter). It is interesting to note that after 30 minutes of electrolysis under these conditions the strong odor of the waste material disappeared and a distinct decolorization of the material had taken place. Also, hydrogen could be observed evolving from the counter electrode.

Results obtained from the limiting current were then used in calculations to obtain the current efficiency of the process. At this stage, since the oxidation reactions of the waste materials leading to CO_2 production are unknown, some simplifying assumptions have been made. Oleic acid, which is

considered to be an average molecular species of the dissolved material has been used in these calculations. The reaction for the complete oxidation of oleic acid is given below:



Assuming 100% current efficiency and having estimated the limiting current (see above), the ideal amounts of CO_2 produced can be determined and are shown in Table 2 along with the actual amount of CO_2 that was measured. The relationship given below was used to determine the ideal amount of CO_2 that could be produced during the reaction where I_L is the limiting current, t is time of electrolysis, n is the number of electrons taking part in the reaction (ie 102) and F is the Faraday Constant.

$$\frac{I_L \cdot t \cdot 18\text{CO}_2}{n \cdot F} \quad - \quad \text{Ideal CO}_2$$

The results are given in Table 2 and show that over the range examined the most effective potential for the oxidation to CO_2 was at 1.4 V (vs NHE) giving a current efficiency of 64%. The examination of a wider range of potentials for the organic reactions is difficult due to the low over potential for oxygen evolution on platinum.

3.2 Packed-Bed Lead Dioxide Electrolyzer

Rationale

An electrolyzer in which a batch of organic material can be continuously passed over a PbO₂ packed-bed electrode has been constructed. The PbO₂ anode was chosen primarily because it is a surface that is known to be highly catalytic towards organic oxidation and is not, for instance, a good oxygen evolving electrode.

Experiments have been performed to assess the oxidative capabilities of this system and has involved the oxidation of phenol and of oleic acid. Phenol was chosen because its partial oxidation can give by-products that often are difficult to oxidize (23) and convenient methodology is available for quantitative analysis of some of the intermediates of the reaction (24) and the results will provide information on the mechanism of breakdown. Oleic acid was chosen since it represents a compound similar to those that may be present in fecal waste and thus represents a guide to how the electrolyzer will perform with waste biomass as well as permitting simple calculations on the current efficiencies to be made.

Preliminary studies on the use of mediators such as Ce³⁺/Ce⁴⁺ as possible oxidizing agents of biomass components has been made using oleic acid as a model system. These mediators may act as homogeneous oxidizing agents, reacting in the solution, which are then continuously reoxidized at the electrode and offer potential to enhance breakdown to CO₂.

Methods and Apparatus

Figure 7 shows a cross section of the experimental reactor. The anode compartment contains a packed bed of 1.3mm spherical lead shot in contact with a pure lead rod and contact plate. The dimensions of the cell are shown in the Figure. The cathode consists of a Pt foil and the anode and cathode compartments are separated by a glass frit. A glass Luggin capillary is placed at the tip of the packed-bed which is linked to a saturated calomel reference electrode. The anolyte enters the anodic compartment from the bottom inlet. Before the electrolysis was performed, a 1M sulfuric acid solution was circulated through the reactor for several hours at with a current of 1 A to generate the lead dioxide surface.

Figure 8 is a schematic of the apparatus. Circulation was effected using a Manostat peristaltic pump at a flow rate of 5 ml/second. The anolyte volume was 400ml and the free reactor volume was 35 ml. Carbon dioxide was sparged from the anolyte reservoir using nitrogen gas and was concentrated in a barium hydroxide solution and assayed as described before. Temperature was maintained by placing the anolyte reservoir over a heater and a thermometer was mounted at the top of the anode compartment. A constant current was maintained as described before. Liquid samples for analysis were taken from a air-tight seal using a syringe. A PAR polarographic analyzer (174A) was used to determine maleic acid concentrations (25) and the benzoquinone was assayed using a Perkin Elmer 3B UV/Vis spectrophotometer.

Phenol Oxidation

The results have been interpreted according to the following sequence (see 24).

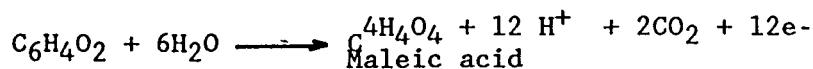
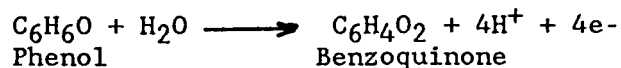

Figure 9 shows the concentration of benzoquinone and maleic acid as a function of time at 25°C; the total amount of CO₂ produced during the reaction is also shown. The flow rate was 5 ml/sec and the current was 1 A and the estimated surface area of the packed bed was estimated to be 1000 cm². The electrolyte contained 1M sulfuric acid. There was a rapid rise in the benzoquinone concentration but the benzoquinone was subject itself to rapid reoxidation after 1.5 hours of the electrolysis. Contrary to expectations, there was not a build-up of maleic acid following the oxidation of benzoquinone indicating that the reaction sequence following the oxidation BQ involves steps not shown in the sequence above. Furthermore, carbon balances show that only 50% of the phenol had been converted to BQ, maleic acid and CO₂ after 6 hours of electrolysis. However, the production of CO₂ occurs at a constant rate from the beginning of the experiment, it is not known what reactions give rise to CO₂ at this early stage. Calculations of the current efficiency have been made using the above reaction sequence and were in the region of 1% for all the reaction conditions studied.

Experiments at 60°C gave enhanced rates of CO₂ production results

otherwise similar to those described above; further analysis showed that under these conditions, the benzoquinone had been oxidized after 10 hours of electrolysis.

Oleic Acid Oxidation

The results in Figure 10 show CO₂ production from oleic acid under different conditions. The current was 1 A and the electrolyte contained 9M H₂SO₄ and all these experiments were performed at 80°C. The equation for the total oxidation of oleic acid to CO₂ is

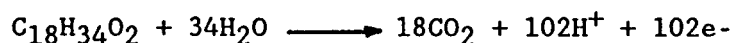

The reaction has been used to calculate the current efficiency for the oxidation of oleic acid when present at a final concentration of 0.02M at 80°C. Current efficiency was calculated by determining the ideal value for CO₂ production in relation to the actual measured value as described above. At this concentration, the current efficiency was 2%. At 0.1 M oleic acid, the current efficiency was 15%. It is not known why higher concentrations give improved efficiencies, however, at higher concentration of oleic acid may be adsorbed in more favorable orientations for the oxidation reactions.

Liquid samples were taken throughout the electrolysis and a preliminary analysis of the intermediates by GC/MS clearly showed that the Kolbe reaction (ie the dimerization of the carboxylic acid) was not occurring in this system since no compounds of molecular weight above that of oleic acid were detected.

An experiment is shown that demonstrates that the addition of the inorganic electron acceptor cerium IV can double the oxidation rate of oleic

acid. Current efficiency was 29%. Although the exact mechanisms are unknown, this indicates that Ce^{4+} is behaving as an oxidant in solution. A similar effect has been shown for cerium IV on coal (20,21) in which the following scheme was proposed,

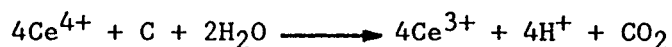

however, the reaction, with coal and with waste biomass, does not necessarily require that the product be CO_2 . If the oleic acid and other components of fecal waste were to undergo electrochemical oxidation only at the electrode surface, then the reaction would occur through collision processes, the rate of which may be low. The use of the reaction mechanism proposed, which would occur in the anolyte, would reduce this difficulty.

4.

CONCLUSIONS AND RECOMMENDATIONS

This study has successfully demonstrated that electrolysis can be used to regenerate CO₂ from fecal waste. The prospects for obtaining high current efficiencies from this process are good.

Noble metal electrodes have low overpotentials for oxygen evolution and offer a limited potential range for the oxidation of fecal biomass. Lead dioxide may be a good surface for the electrochemical oxidation of biomass and are worthy of further study.

Elevated temperatures can improve the current efficiency for CO₂ production from biomass.

Strong oxidizing agents that can be regenerated electrochemically such as Ce⁴⁺ are effective in bringing about the oxidation of biomass components and need to be investigated more thoroughly.

ACKNOWLEDGEMENTS

The authors wish to thank Cinda Chullen of Crew and Thermal Systems at Lyndon B. Johnson Space Center for the guidance given during this work. Thanks are also due to Tom Rogers, Frank Little, Oran Nicks and other members of the Regenerative Concepts Group at Texas A & M University for the many stimulating discussions regarding the application of electrochemical systems in CELSS.

- (1) Lance, N. Jr. and F.H. Schubert, ASME Paper, 81-ENAs28, (1981) 1.
- (2) Schubert, F.H., T.M. Hallick and E.P. Koscenski, NASA CR-166141, (1981).
- (3) Tischer, R.G., B.P.Tischer, L.R.Brown, and J.C. Mickelson, Develop. Ind. Microbiol. 4 (1963) 253.
- (4) Tischer, R.G., B.P.Tischer and D.Cook, Develop. Ind. Microbiol. 3 (1962) 72.
- (5) NASA Contract NAS 1-11662, Lockheed Missiles & Space Co. (1978).
- (6) Oertel, R.Z., Angew. Chem. 26 (1913) 246.
- (7) Choudhury, F.H., M.H. Khundkar, Pakistan J.Sci.Res., 5 (1953) 77.
- (8) Lenoble, E., Russa, 4 (1929) 1839, Chem. Abst. 24:4149.
- (9) Neuberg, C., Biochem. Z., 17 (1909), 270 Chem. Abst. 3:1862.
- (10) St. John, M.R. (1983) U.S. Patent 4 395 316.
- (11) Bockris, J.O'M., B.J. Piersma and E. Gileadi, Electrochimica Acta 9 (1967) 1329.
- (12) Yao, S.J., S.K.Wolfenson, M.A.Krupper and K.J.Wu, in: Charge and Field Effects in Biosystems, edited by M.J.Allen and P.N.R.Usherwood (1984) 410, Abacus Press.
- (13) R.W. Keller, J.M. Brown, S.K. Wolfson and S.J. Yao, IEEE Frontiers in Engineering Health Care 2 (1980) 178.
- (14) Yao, S.J., J.M.Brown, S.K. Wolfson, K.V. Thrivikraman and M.A.Krupper, IEEE Frontiers in Engineering Health Care 4 (1982) 24.
- (15) Murphy, O.J., J.O'M. Bockris and D.W. Later, Int. J. Hydrogen Energy, 10 (1985) 453.
- (16) Okada G., V. Guruswamy and J.O'M. Bockris, J.Electrochem. Soc. 128

(1981) 2097.

- (17) Coughlin, R.W. and M. Farooque, Nature, 279 (1979) 301.
- (18) Coughlin, R.W., M. Farooque, J. Appl. Electrochem. 10 (1980) 729.
- (19) Baldwin, R.P., K.F. Jones, J.T. Joseph, T.L. Wong, Fuel 60 (1981) 739.
- (20) Dhooge, P.M., D.E. Stilwell and S-M. Park, J.Electrochem. Soc. 129 (1982) 1719.
- (21) Dhooge, P.M. and S-M. Park, J.Electrochem. Soc. 130 (1983) 1029.
- (22) Taylor, N., C. Gibson, K.D. Bartle, D.G. Mills, and G. Richards, Fuel 64 (1985) 415.
- (23) Smith de Sucre, V. and A.P. Watkinson, Can. J. Chem. Eng. 59 (1981) 52.
- (24) Sharifian H. and D.W. Kirk , J.Electrochem. Soc. (1986) 921.
- (25) Chey, W.and R.N. Adams, J. Electroanal. Chem. 75 (1977) 731.

Table 1 Contents of Artificial Fecal Waste

Waste Component	Weight (kg)	% Of Total Dry Weight
Cellulose	0.60	33%
<u>Torpulina</u>	0.43	25%
<u>E.coli</u>	0.12	7%
Casein	0.17	10%
Oleic acid	0.37	20%
KCl	0.04	2%
NaCl	0.04	2%
CaCl ₂	0.03	1%
Water	2.8	-

f

Table 2 Artificial Fecal Waste Constant Potential Electrolysis

Potential (V vs NHE)	CO ₂ Measured (moles/hour)	CO ₂ Ideal (moles/hour)	I _L calculated (mA/cm ²)	Current Efficiency
1.4	0.5 10 ⁻⁴	0.78 10 ⁻⁴	0.46	64%
1.5	1.0 10 ⁻⁴	1.8 10 ⁻⁴	1.15	55%
1.6	1.0 10 ⁻⁴	2.6 10 ⁻⁴	1.13	38%
1.7	1.5 10 ⁻⁴	2.76 10 ⁻⁴	1.61	54%
1.8	1.5 10 ⁻⁴	2.88 10 ⁻⁴	1.69	52%

Table 3 Constant Current Electrolysis of Artificial Fecal Waste

Potential (V vs NHE)	Temperature (oC)	CO ₂ Measured (moles/hour)	CO ₂ Ideal (moles/hour)	Current Density (mA/cm ²)	Current Efficiency
2.4	25	6.8 10 ⁻⁴	6.55 10 ⁻³	38.46	10%
2.4	60	6.0 10 ⁻⁴	6.58 10 ⁻³	38.46	10%
2.4	80	1.16 10 ⁻³	6.58 10 ⁻³	38.46	18%
2.4	100	1.3 10 ⁻³	6.58 10 ⁻³	38.46	19%

Figure 1

A SCHEMATIC REPRESENTATION OF THE METHOD USED
FOR THE ELECTROCHEMICAL DEGRADATION OF ORGANIC
HUMAN WASTES

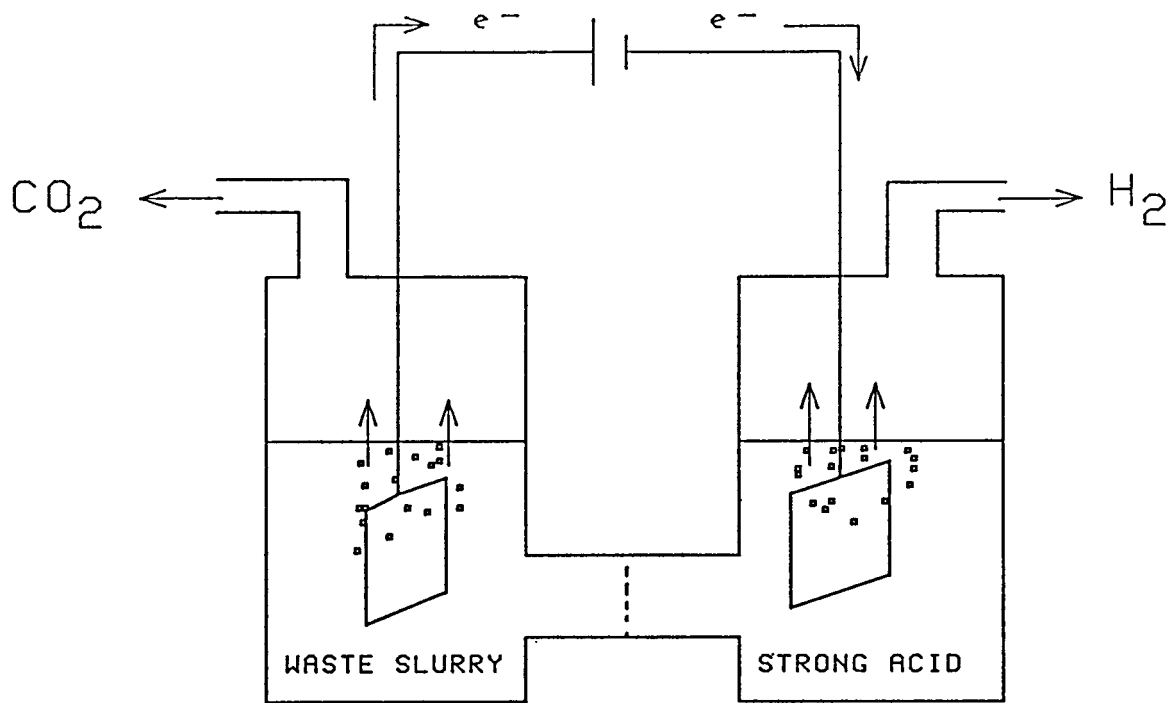

GENERAL ANODIC REACTION

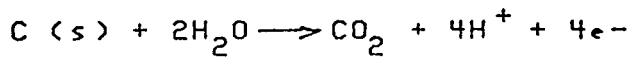

CATHODIC REACTION

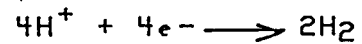
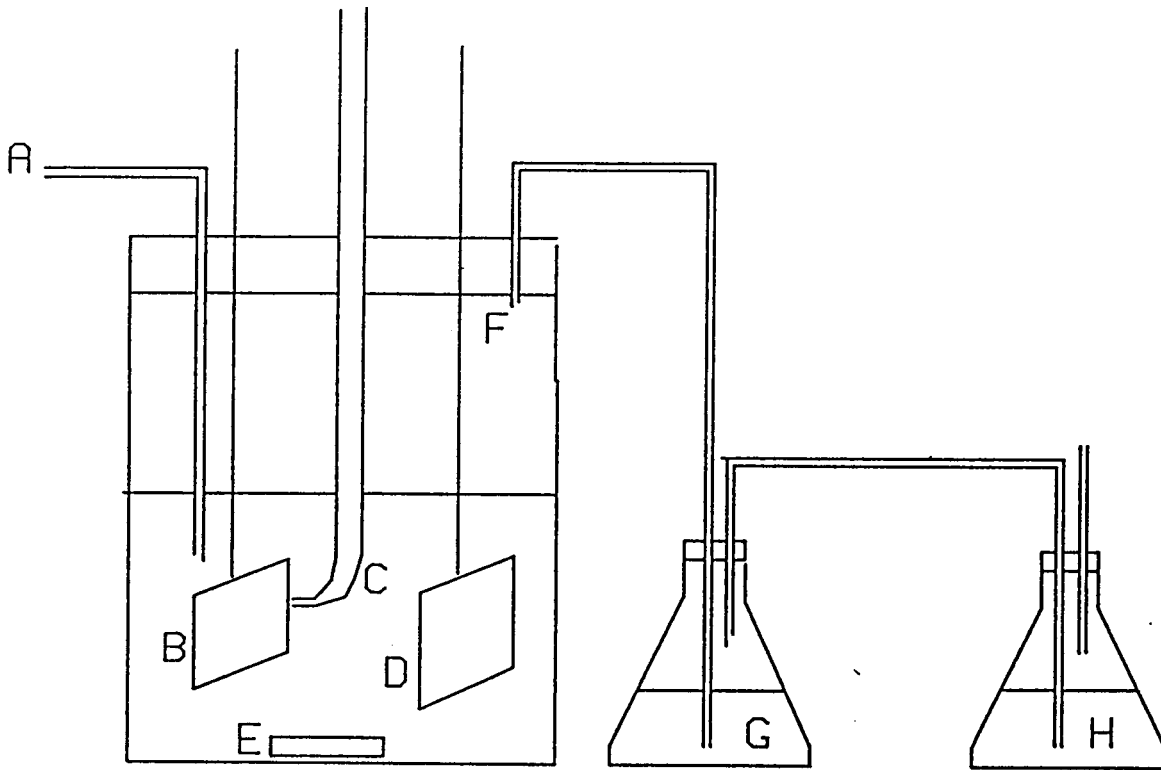

FIGURE 2

REACTION CELL FOR BIOMASS ELECTROLYSIS



A N₂ INLET

B PLATINUM WORKING ELECTRODE

C LUGGIN CAPILLARY

D PLATINUM COUNTER ELECTRODE

E MAGNETIC STIRRER

F GAS OUTLET

G WATER TRAP

H BARIUM HYDROXIDE SOLUTION

FIGURE 3

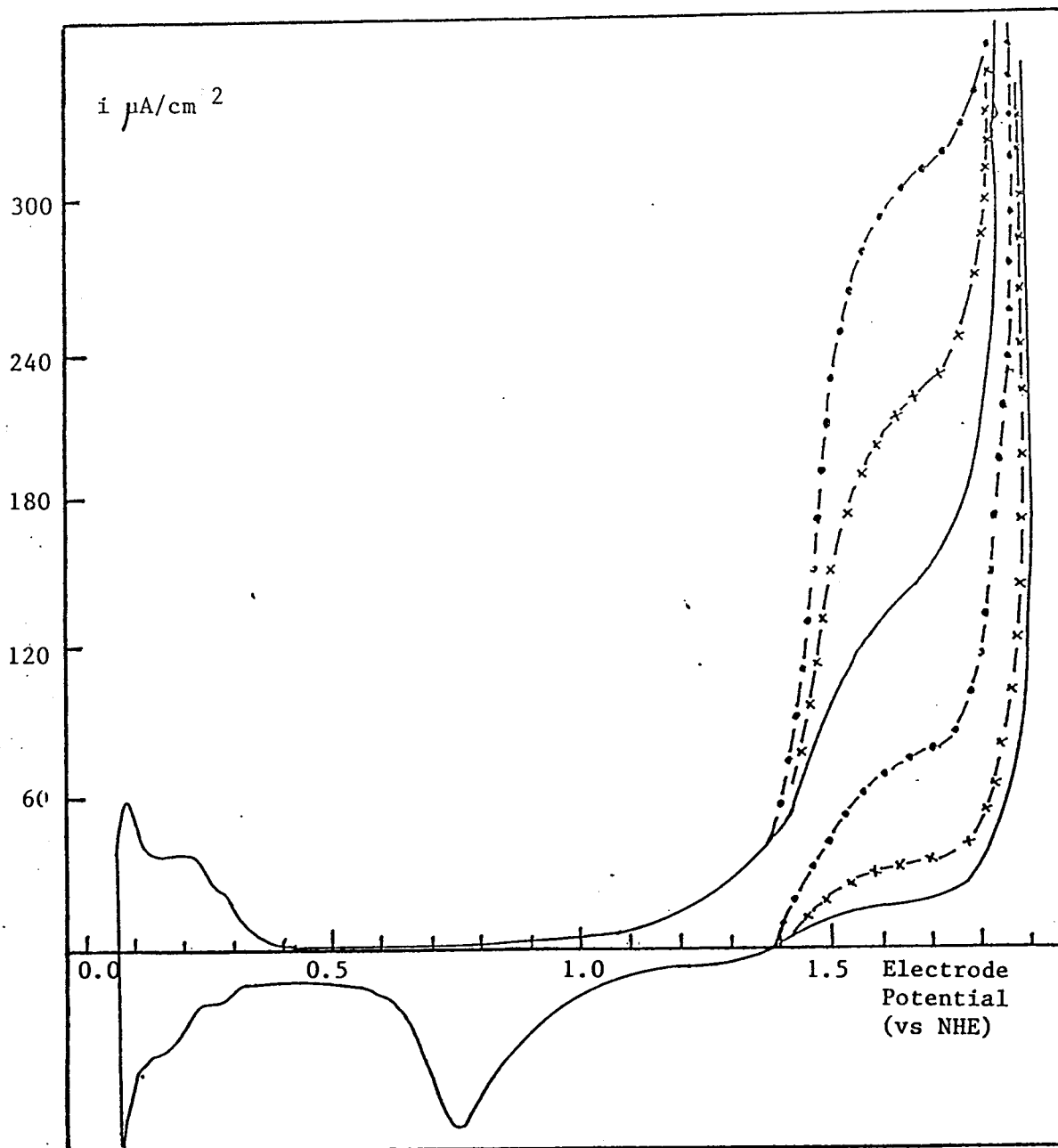

POTENTIAL SWEEP MEASUREMENTS OF ARTIFICIAL WASTE

The reaction temperature was 25°C. Potential sweeps were made at 50mV/sec using platinum electrodes of area 26 cm². Concentrations corresponding to 0.93 (—), 1.40 (-x-) and 1.87 (-•-) g/l dry weight in 5M H₂SO₄ are shown.

FIGURE 4

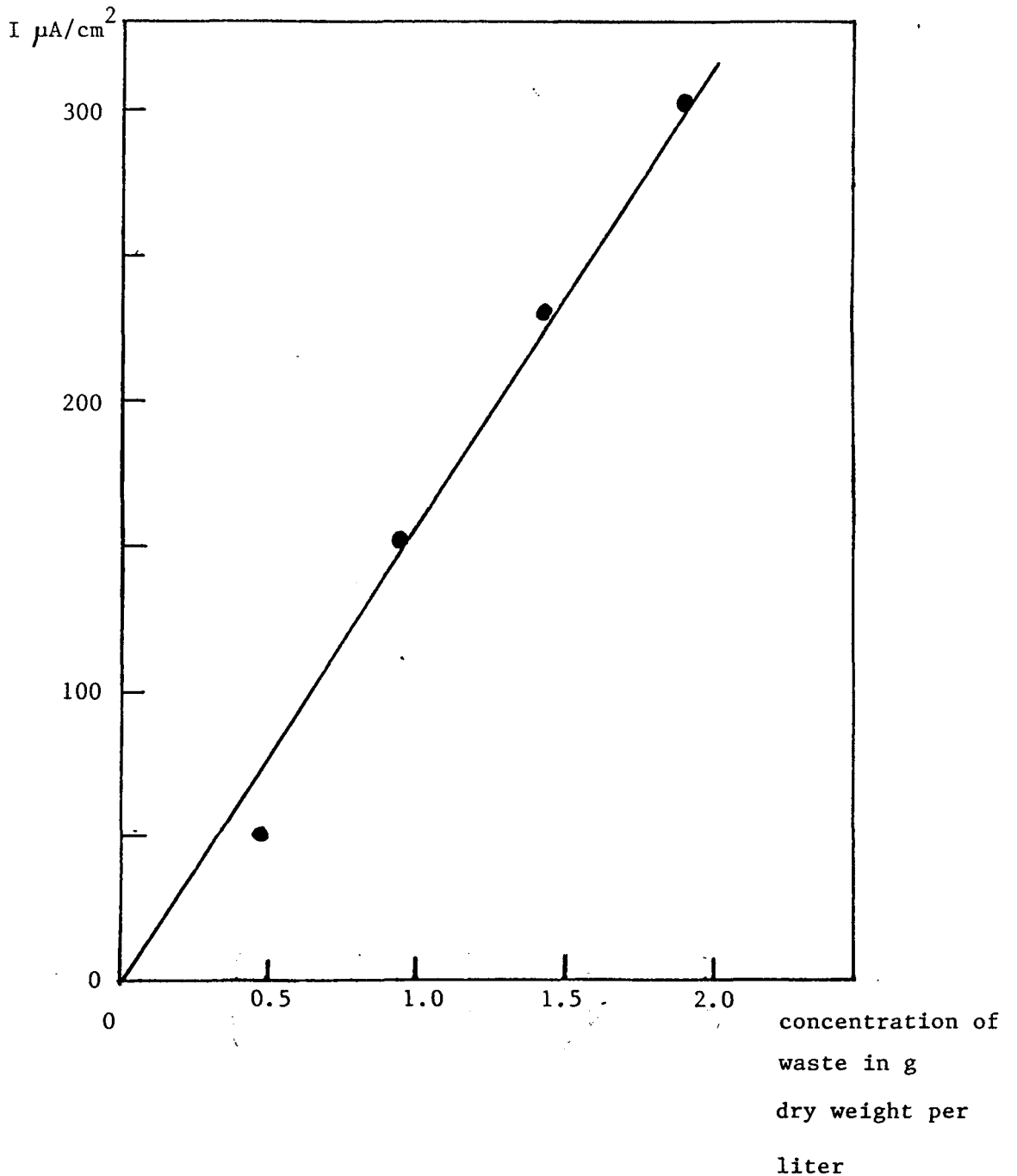

VARIATION OF LIMITING CURRENT WITH CONCENTRATION
OF ARTIFICIAL FECAL WASTE

Limiting currents were obtained from potential sweep
measurements at 25°C at a sweep rate of 50 mV/sec.

FIGURE 5

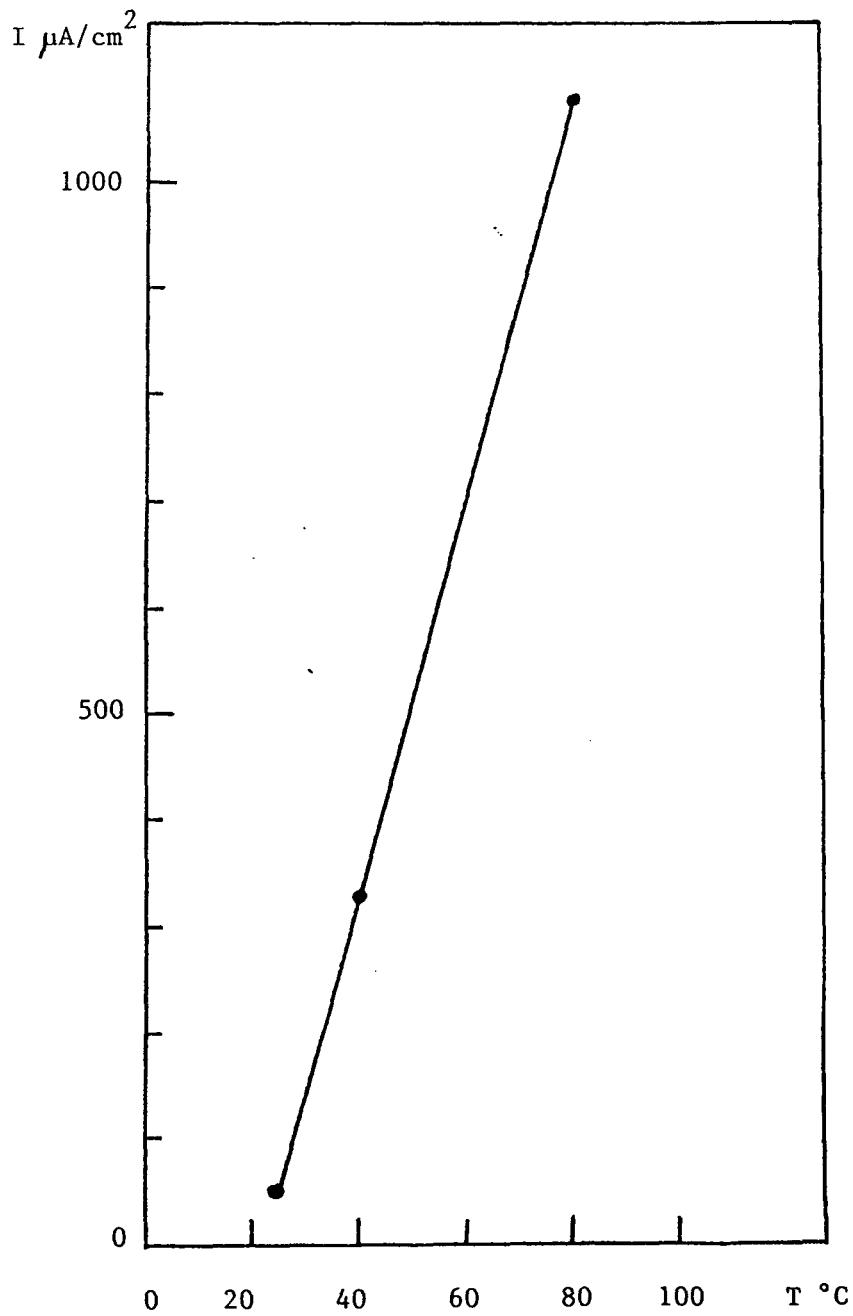

EFFECT OF TEMPERATURE ON LIMITING CURRENT

Measurements were made using potential sweeps at 50 mV/sec on a Pt electrode (26cm^2) at a concentration of artificial waste corresponding to 1.87 g dry weight/liter.

FIGURE 6

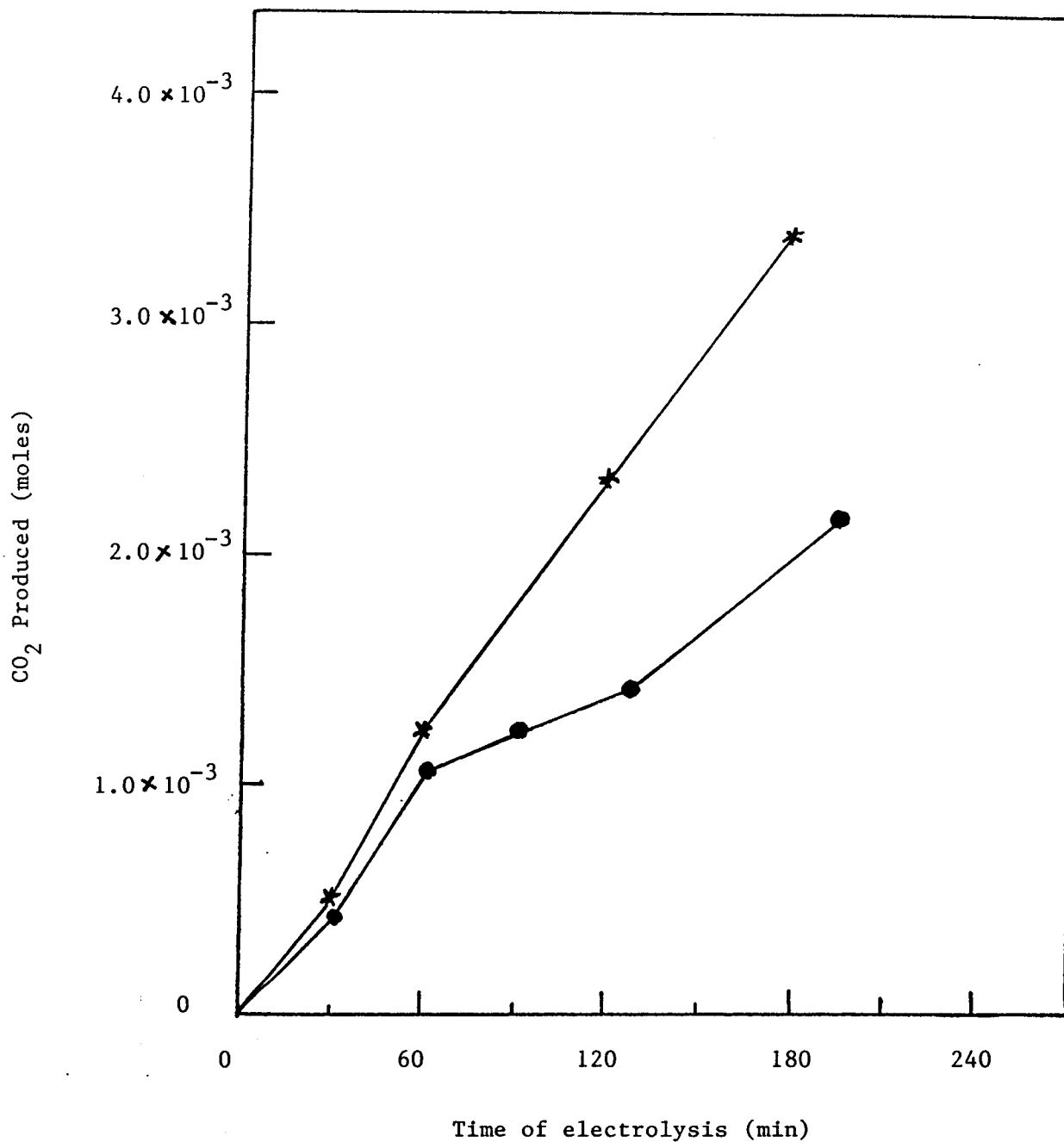

EFFECT OF TEMPERATURE ON CO₂ PRODUCTION FROM ARTIFICIAL FECAL WASTE.

Constant current electrolysis was performed at 38.46 mA/cm². Waste concentration was 3.46g dry weight. The results for 25°C (●) and 100°C (*) are shown.

FIGURE 7

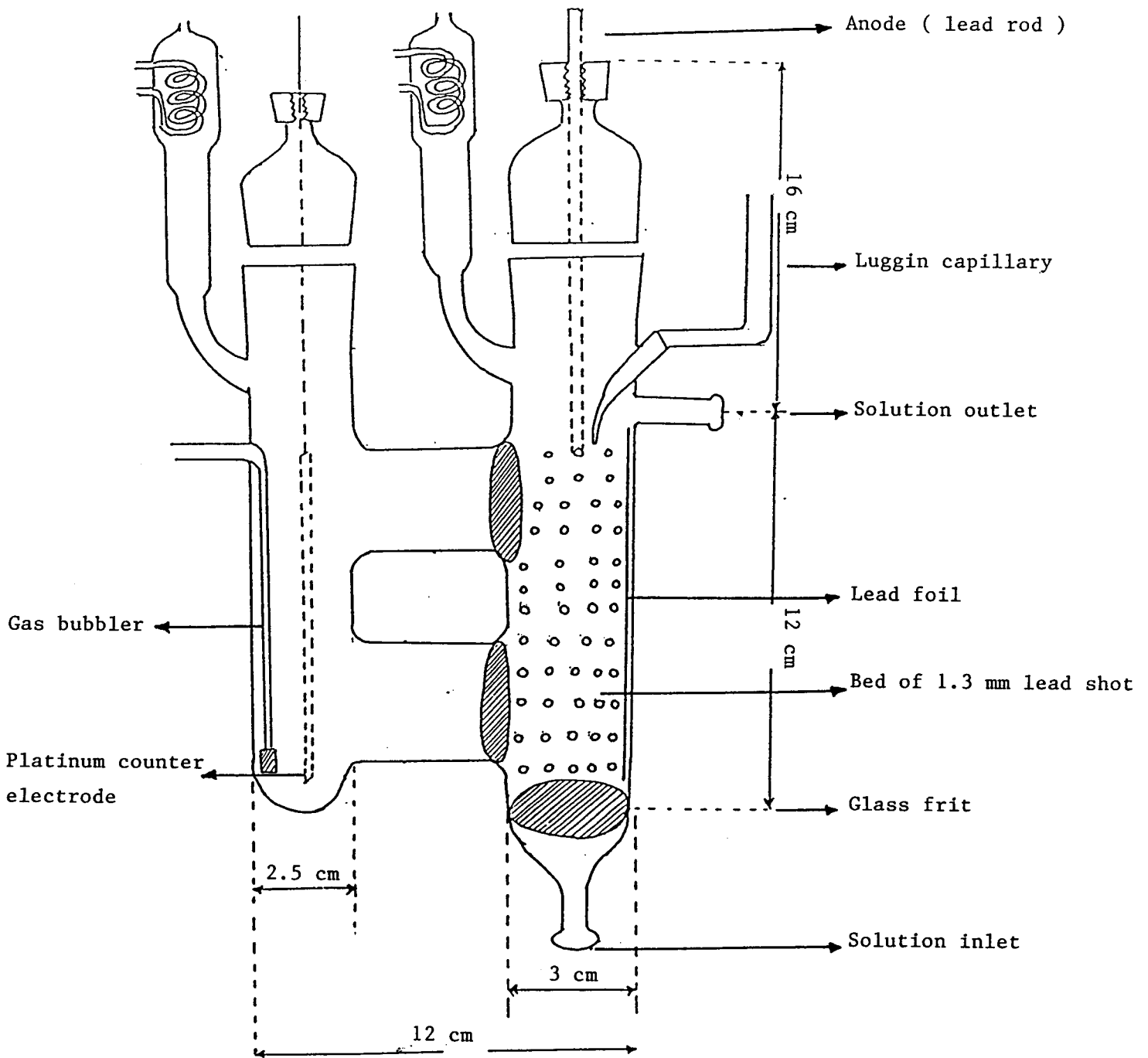

PACKED-BED LEAD DIOXIDE CONTINUOUS FLOW ELECTROLYZER

FIGURE 8

FLOW SYSTEM FOR PACKED-BED PbO_2 REACTOR

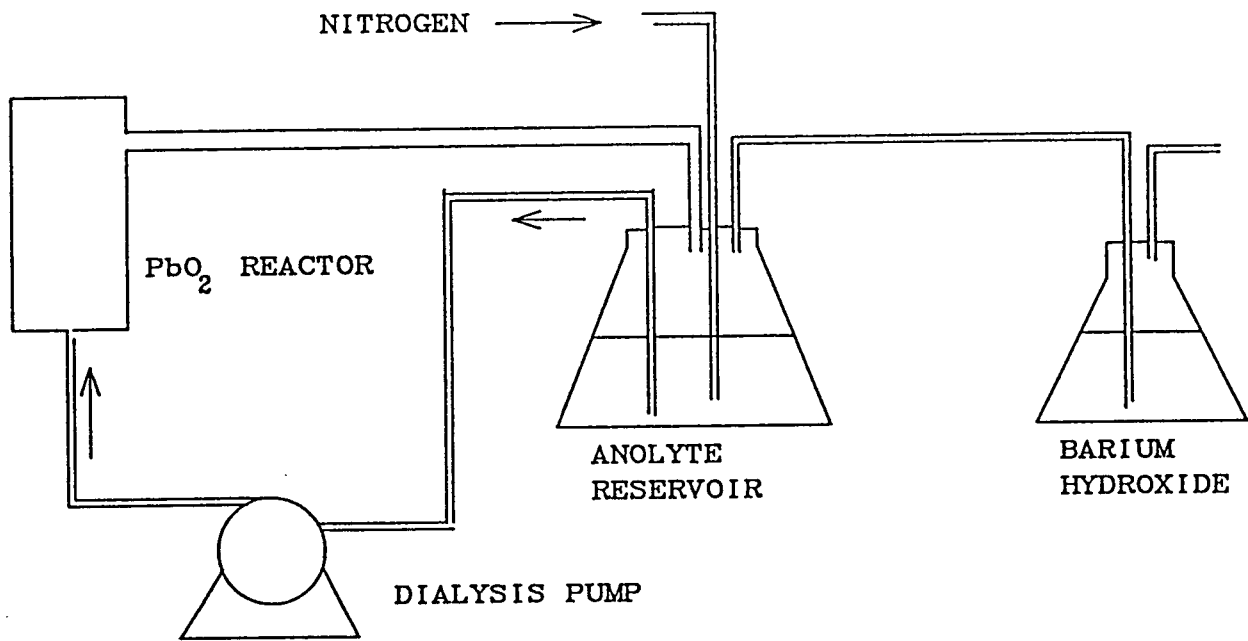
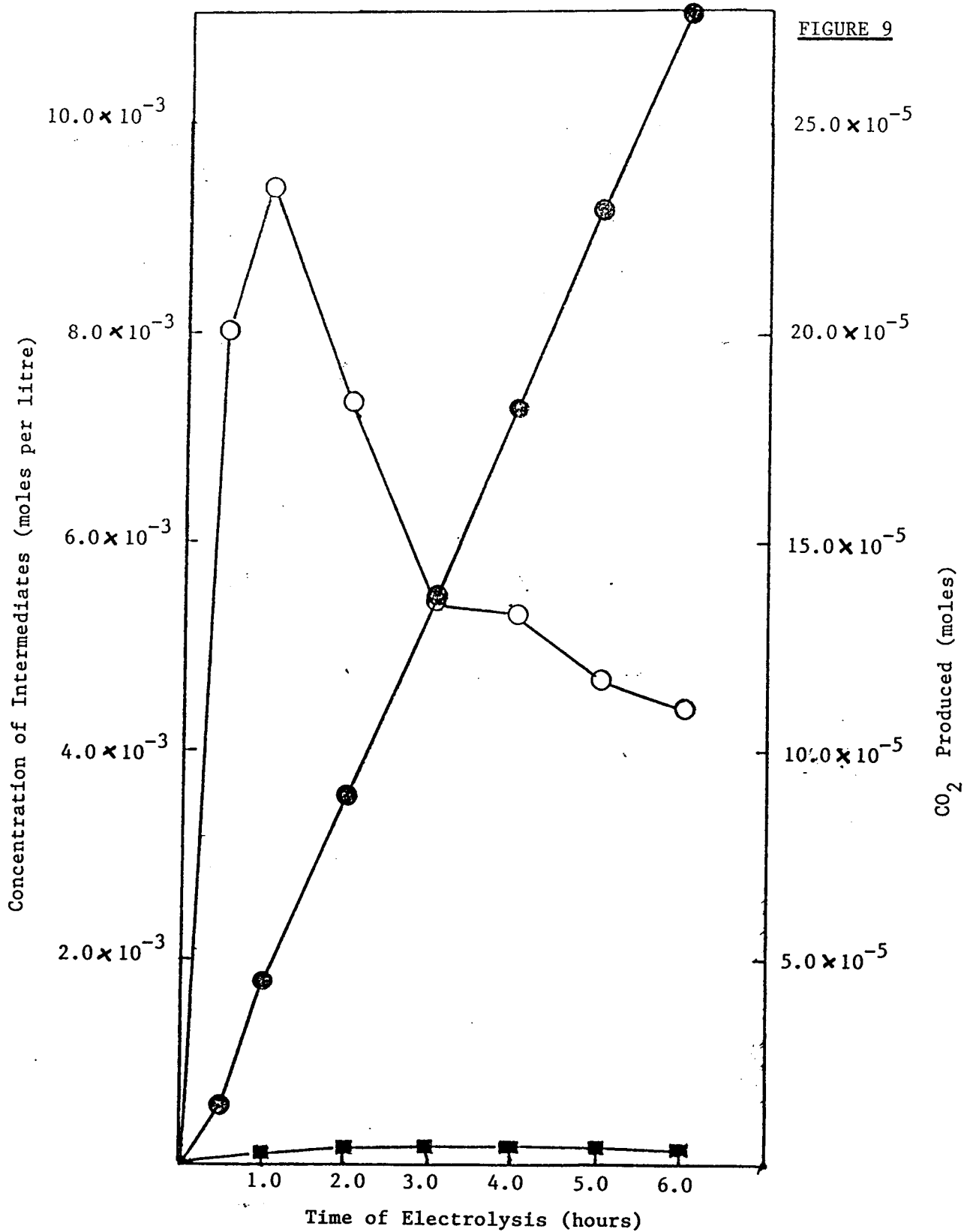

FIGURE 9



PHENOL OXIDATION ON PbO₂

The total volume of electrolyte was 400ml and contained 1M H₂SO₄. The initial concentration of phenol was 0.014M. Maleic acid (■) and benzoquinone (○) concentrations are shown. CO₂ production is shown (●). The reaction temperature was 25°C.

FIGURE 10

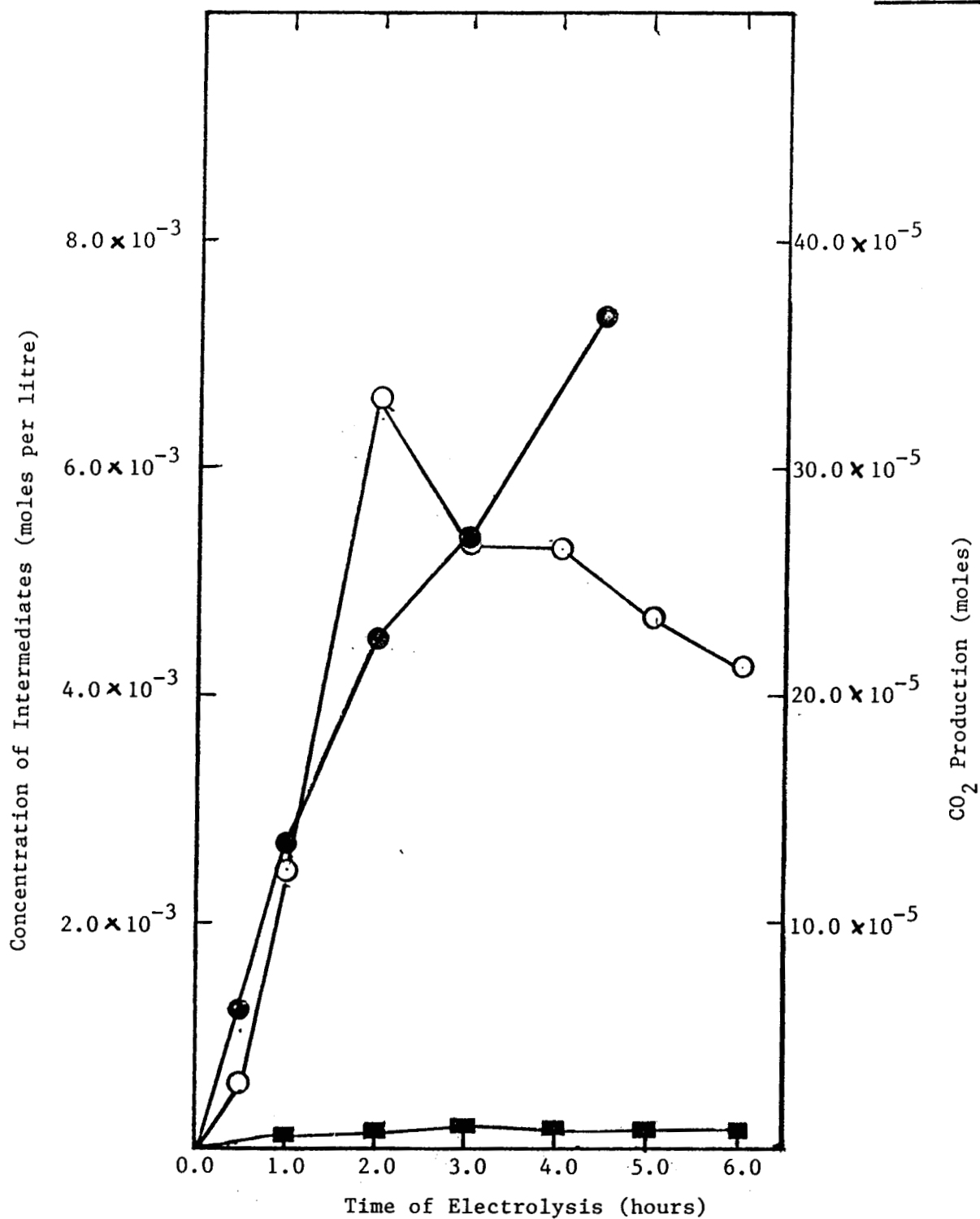

PHENOL OXIDATION ON PbO₂

The total volume of electrolyte was 400 ml and contained 1M H₂SO₄. The initial concentration of phenol was 0.014 M. Maleic acid (■), benzoquinone (○) concentrations were measured and the amount of CO₂ evolved was determined (●). The reaction temperature was 60°C.

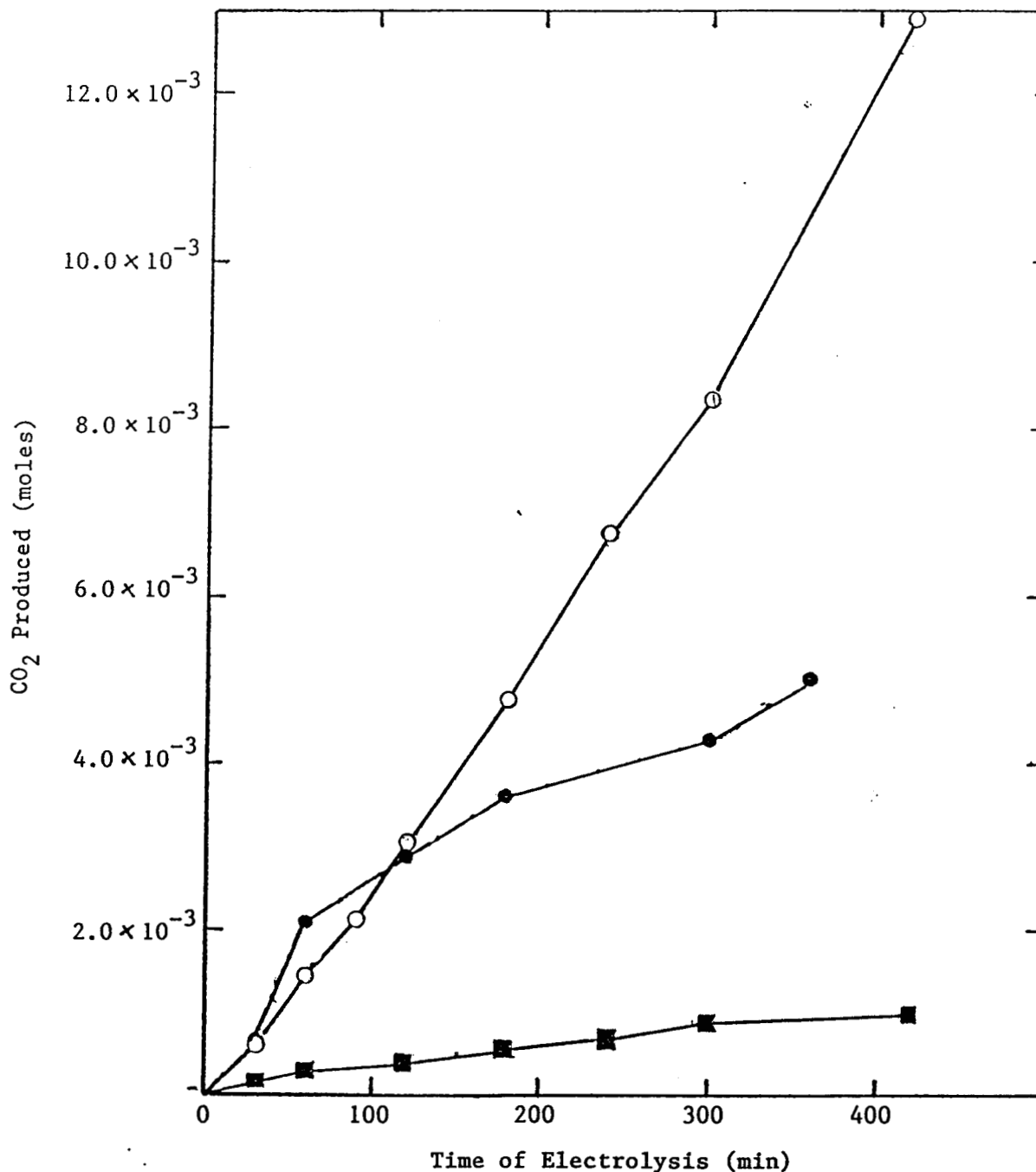

OLEIC ACID ELECTROLYSIS ON PbO₂

The total volume of electrolyte was 400ml circulating at 5ml/sec. All experiments were conducted at 80°C in the presence of 9M H₂SO₄. The electrolyte contained 0.02M oleic acid (■), 0.1M oleic acid (●), and 0.1M oleic acid with 1.2 x 10⁻⁴ cerrium (○).