

**Manipulator Arm Design for the Extravehicular Teleoperator Assist Robot (ETAR):\*  
Applications on the Space Station**

**Margaret M. Clarke**  
Space Station Systems Division  
Rockwell International Corporation  
12214 Lakewood Avenue  
Downey, California 90241  
(213) 922-0785

**Charles J. Divona**  
and  
**William M. Thompson**  
NSA Electro-Mechanical Systems Division  
2701 Saturn Street  
Brea, California 92621  
(714) 996-4670

**ABSTRACT**

The preliminary conceptual design of a new teleoperator robot manipulator system for Space Station maintenance missions has been completed. The system consists of a unique pair of arms that is part of a master-slave, force-reflecting servomanipulator. This design allows greater dexterity and greater volume coverage than that available in current designs and concepts.

The teleoperator manipulator is specifically designed for space application and is a valuable extension of the current state-of-the-art earthbound manipulators marketed today.

This paper describes the manipulator and its potential application on the Space Station.

**INTRODUCTION**

The potential use of a teleoperator robot system in and around the Space Station is being considered as an aid to astronauts in performing extravehicular activity (EVA). This paper describes the preliminary conceptual design work for a telerobot for Space Station maintenance and the anticipated application of the device for maintenance and tending of the Space Station user payload complement. Earlier work by the same team, completed in 1985, established mission objectives, equipment and interface requirements, and the environmental constraints of a free-flying telerobot. This early work has been reported extensively (References 1-5). In the current work we analyzed requirements for typical EVA maintenance tasks and then developed detailed manipulator concept solutions to those requirements. The resulting application concept employs the extravehicular teleoperator assist robot (ETAR) as a dedicated EVA tool used for tending the Space Station user payloads. The ETAR will assist the Space Station crew during EVA, either directly assisting an EVA astronaut or working alone in the EVA environment. The ETAR would be controlled by a second astronaut within the shirt-sleeve confines of the station as intravehicular activity (IVA). The IVA astronaut views the EVA operation through a window, from the cupola, or on a closed-circuit TV monitor. The ETAR design emphasizes maximum dexterity, minimum weight, high reliability, and optimum control characteristics. ETAR manipulator requirements and solutions were developed through the first five subtasks listed below. Lastly, potential applications were developed to use the ETAR to maintain the Space Station EVA payload complement.

1. Analysis of maintenance task requirements
2. Manipulator mechanical requirements
3. Preliminary mechanical design\*\*
4. Operational requirements
5. Control concepts
6. Applications to user payload tending

**ANALYSIS OF MAINTENANCE TASK REQUIREMENTS**

We identified 21 typical tasks selected from an assortment of maintenance missions and representing a wide range of transfer routes, dimensions, mass, and handling requirements.

To help define requirements further, we selected three test cases from the sample for further study. They involved replacing the following equipment: solar array on the Advanced X-Ray Astrophysics Facility (AXAF), faint object spectrograph (FOS) on the Hubble Space Telescope (HST), and multimission modular spacecraft (MMS) modules in common use on present and future satellites. The reasons for choosing these three cases are summarized in Table I.

**Table I. Test Case Characteristics and Handling Requirements**

Test Case	Characteristics	Handling Requirement
Solar array	Fragile, large, flexible	Precise force control
FOS	Special covers and latches	Dexterity
MMS	Frequent use	Must be quickly and easily performed

**MANIPULATOR MECHANICAL REQUIREMENTS**

The preceding information established the basic configuration, degrees of freedom, and size requirements for the ETAR manipulator slave arms. The criteria used in establishing these requirements provide a capability to accomplish the above tasks and to be of general assistance to the EVA crew.

\*Work performed under Rockwell Contract SC000730-01 with Essex Corporation to support NASA-36629

\*\*Preliminary designs were evaluated with respect to existing teleoperated manipulator configurations. The results of this evaluation are reported in Reference 9.

## Configuration: Number of Joints

The ETAR arm will be controlled predominately in a teleoperated mode; that is, the crew person will control the remote arm from within the spacecraft using familiar hand and arm movements while viewing the EVA operation from the cupola, a window, or a TV monitor. We will use the arm kinematics that approximate a man-like configuration and arm motions for the operator to relate most efficiently to, and control the motions of, the ETAR arm. To implement this, an anthropomorphic configuration was assumed with the arm containing a shoulder, elbow, and wrist joint.

## Degrees of Freedom (DOF's) of Each Joint

The shoulder has two DOF's: pitch and yaw. This configuration is analogous to the human shoulder, which allows the arm to swing out to the side (yaw) and forward (pitch). Most of the contemporary manipulators in the nuclear industry incorporate pitch only. These include the advanced servomanipulator (ASM) developed at Oak Ridge National Laboratory (ORNL), the M-2 (Central Research Laboratories), and the RM-10 (Remote Technology Corporation). Incorporation of a yaw DOF greatly extends the total coverage capability of the arm. This capability is of major importance because it minimizes the redocking requirements of the space vehicle that carries the arm.

The elbow has both pitch and yaw. These DOF's are standard on most anthropomorphic configurations, allowing the wrist and hand to be brought in close to the body.

A 3-DOF wrist joint is incorporated in the ETAR arm. The motions are pitch, yaw, and roll. The pitch-yaw-roll wrist is a dexterous, back-drivable configuration that can be designed to be singularity free. Our prime design candidate for the wrist is the tendon-linkage type in which all wrist drives (including the wrist roll) are located in the forearm. This arrangement is far superior to any currently proposed concepts advocating designs that place the wrist roll drive forward of the pitch-yaw axis.

For this study, only an open-close, tong-type end effector will be considered. Other special hand configurations will be considered later.

Figure 1 shows the ETAR arm with the DOF's. The arm has 7 DOF's plus the end effector motion. This is one more than the minimum needed to position an object anywhere within the operating envelope in any angular orientation. The extra DOF permits

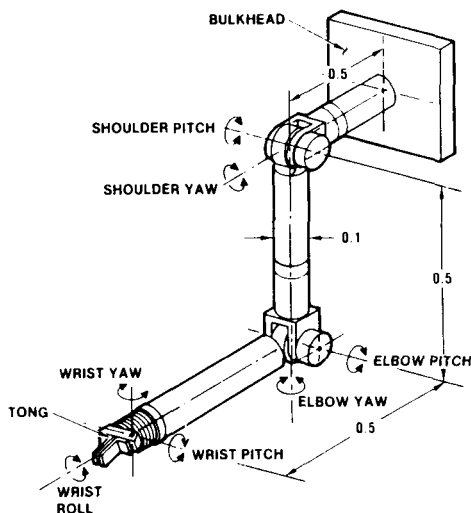

Figure 1. ETAR Arm Degrees of Freedom and Dimensions

not only a greater operating envelope, but also the capability of reaching points in space with two different arm configurations. This allows the arm to reach objects that would otherwise be impossible.

## Bases for Overall Size

The 21 orbital maintenance representative test cases were reviewed to establish the overall size envelope of the ETAR. The largest dimension of each object to be transferred was established and the mean and median determined excluding items that were extremely large or for which we lacked sufficient information. The results are the following:

- Mean (17 items) = 3.14 m
- Median (17 items) = 3 m

In establishing the ETAR arm length, it was assumed that a two-arm configuration would be employed on the assist robot, the arms would be separated by a distance of 0.75 m, and the total wrist-pivot to wrist-pivot dimension would correspond to the 3-m dimension determined above. This assumption is based on the outstretched dimension of the arms. The 0.75-m separation is a good compromise for establishing a reasonable zone of mutual operation for both arms. From the above, the dimension of a single arm, from the wrist-pivot to the shoulder-pivot, is the following:

$$D_{w-s} \frac{3 - 0.75}{2} = 1.125 \text{ m} \quad (1)$$

To maximize commonality of parts and modules, the wrist-to-elbow and elbow-to-shoulder dimensions are assumed equal to half of  $D_{w-s}$  or

$$D_{w-e} = D_{e-s} = D_{w-s} = 0.5625 \text{ m} \quad (2)$$

To accommodate the shoulder yaw motor/drive, a distance of 0.5 m between the robot vehicle bulkhead and the shoulder axis was assumed.

Figure 1 also shows the ETAR dimensions. The upper and lower arm diameter (0.1 m) is based on the estimated size of the motors mounted inside the arms.

The volumetric coverage of the ETAR is significantly greater than existing manipulators, such as the M-2, ASM, and RM-10. This is a direct result of the shoulder yaw DOF. Except for the shoulder yaw, the other major DOF's are symmetrical with respect to the bulkhead. In this configuration, the bulkhead can be oriented at any position in space and allows the arms to interface effectively with the work task. The wrist pitch and yaw allow the location of the hand or end effector to be anywhere within a hemisphere perpendicular to the lower arm. We assume that the tong opening will allow the gripping of objects as large as 9 cm.

## PRELIMINARY MECHANICAL DESIGN

The preliminary mechanical design configuration (Figure 1) incorporates a similar pitch-yaw joint in the shoulder and elbow and a 3-DOF pitch-yaw-roll wrist. The shoulder and elbow yaw drives are located above the respective joints within the cylindrical arm structures. The pitch drives are concentric with the pitch axis. All three drives for the wrist are in the lower arm.

The wrist mechanism is based on a design described by Rosheim (Reference 7). The mechanism features 180 deg of pitch and yaw and continuous bidirectional roll. It is singularity free,

back-drivable, and mechanically efficient. Two push-pull rods drive the pitch and yaw motions. These are actuated via linear ball screws by motor-resolvers located in the forearm. The roll drive motor directly rotates the tool plate at the end of the unit.

## OPERATIONAL REQUIREMENTS

Because the purpose of the ETAR manipulator arm is to assist or conduct many of the operations performed by an EVA astronaut, we used a human arm as a reference base and then stated ETAR arm operational characteristics compatible with astronaut capabilities to perform identified tasks. Resulting ETAR arm operational characteristics are discussed below.

### Force

A reasonable operational capability for an astronaut is to exert a steady force of 90 n (20 lbf) with the hand in any direction. This is, therefore, the design force capability of the ETAR arm: any DOF can exert this force when acting alone. With several DOF's acting, the force capability is the vector addition of forces. Each DOF also has a larger peak capability of 135 n (30 lbf) for short times. Power supply limitations and motor heating establish the peak force value and its time duration.

### Speed

The minimum speed capability was based on operating experience with master-slave manipulator systems. A speed capability of 1 m/sec (40 in./sec) does not noticeably impede the motions of the operators. They are not forced to fight the system to increase speed if it has force feedback or distracted by lack of synchronization with no force feedback.

### Force Sensitivity

The ability to detect small forces or small changes in force is a further requirement. Again, manipulator operational experience indicates that a sensitivity of 2 percent or less of maximum force is desirable. This requirement is related to the one for low friction. The operator-sensed friction from bearings, gears, motor brushes (if any), etc. must be significantly less than 2 percent.

### Natural Control

The above characteristics will provide the system with natural control. The ultimate objective is to achieve telepresence—the operator has the sensation of being at the work place and not working through an intermediate device. Anything that detracts from that illusion, such as force and speed limitations, reduces operational effectiveness and efficiency. In addition, the choice of DOF's and configuration of the master also affect natural control. The latter also influences the degree of dexterity the system must have. The configuration and DOF's of the arm and master must not require awkward maneuvers to perform the required operations.

### Reliability

Finally, all of the above features and characteristics must be achieved with a minimum of mechanical complexity and with highly reliable, space worthy components.

## CONTROL CONCEPTS

### ETAR Arm Drive Systems

We have chosen direct drive motors in the arms for arm actuation. This eliminates steel cables, tapes running over pulleys, or torque tubes and gear drives found in current servomanipulators. The

ETAR concept takes advantage of the microgravity environments by placing the motors in the arms. This eliminates much of the mechanical complexity, friction, and maintainability and reliability problems associated with earthbound designs.

The motors in this design are low-speed, high-torque, brushless servomotors. The low speed and high torque require little or no gearing. Some commercially available brushless motors operate in a speed range of less than 1 r/sec and produce high output torque. They almost meet the requirements of speed and torque for some of the wrist motions and, therefore, could be applied with only a small advancement in the state of the art. The shoulder and elbow motors, however, will require further development, incorporation of gearing, or both.

The mechanical power output of each motor and, hence, the electrical power input is approximately the same. This is because each motor must produce the same maximum linear force of 90 N (20 lbf) and the same maximum linear speed of 1 m/sec (about 40 in./sec). For example, although the torque arm lengths are longer for a shoulder motor than for a wrist motor, the rotational speed for the shoulder is proportionally lower to achieve the same tangential velocity.

All of the motors include an integral, high-accuracy, brushless resolver as a position transducer. Tachometer generators are not included since state-of-the-art control electronics can easily derive velocity signals from the position signals.

### Control System

Each of the candidate arms can be controlled in either a teleoperator or preprogrammed robotic-type mode. In the teleoperator mode, the crew person remains active in the control loop, receiving information from the remote task site through viewing and force reflection. The crew person then controls the remote manipulator arms from the IVA control station. In the robotic mode, the manipulator arms are programmed to perform tasks autonomously. The crew person is not active in the control loop, but may assume a vigilant role.

### Basic System-Teleoperator Mode

In a teleoperator mode, a special type of control system must be used. The position-position, force reflecting servomechanism (FRS) without force transducers is the classical system used in all operating servomanipulators. One of these systems will be used for each DOF of the ETAR servomanipulator.

The FRS consists of two positional servomechanisms connected bilaterally so that the input of one is the output of the other. The combination works to produce position and velocity correspondence between the two systems. Force reflection is produced by a positional or velocity error between the two systems. Both systems try to reduce the errors—one by pushing against a load or obstruction, the other by pushing against the operator. If both systems have the same components, it is a one-to-one system and the forces are equal.

### Robotic Configuration

The servomechanisms described above can be driven not only in teleoperator mode by operator-generated signals, but also in robotic mode by a preprogrammed signal. The preprogrammed signal can be stored in a memory medium locally or remotely. The source of the programmed signal could be a teaching operation which an operator runs through a sequence of motions and position command signals are recorded for playback. Another source is a computer-calculated and -generated sequence. A combination of both can also be used.

## Master Controller

We recommend a replica master controller for the ETAR manipulator arms. We also considered, but do not recommend, 6-DOF hand controllers.

## Replica Master

Our basic concept for the master controller is a replica of the slave and consists of two skeletal-type replica master arms on a common mounting structure. It resembles the slave's configuration, though it may be scaled down in size. It provides the crew person with a natural control system. Experience with earthbound manipulator systems has indicated that skeletal slave-replica master controllers are easy to operate, safe, and simple enough to be readily maintainable.

## 6-DOF Hand Controllers

Although we did review the state of the art of 6-DOF hand controller, we are not recommending it as a controller for ETAR. For example, Corker and Bejczy (Reference 8) at Jet Propulsion Laboratory developed a 6-DOF force-reflecting, universal hand controller (FRHC). It has an operating volume of about 1 ft and is a compact device that saves space in the master station. The main reason it was not chosen as the prime concept is that it cannot accommodate the seventh DOF in a natural way. In addition, the motions of each DOF do not coincide with those of the slave arm. Therefore, the DOF's are not independent, and coordinate transformations must be performed in the control system to resolve the slave motions. The additional computation and potential cross-coupling between DOF's would result in a more complex control system and potential stability problems.

## ETAR Complete Control System

As depicted in Figure 2, a complete ETAR system consists of two operating arms, TV systems, and auxiliary systems. The master station provides teleoperator manual controls, appropriate automatic control and ETAR transporter (carriage) controls. Electric power to the system is provided via bus bars, with signal control via infrared or laser transmission.

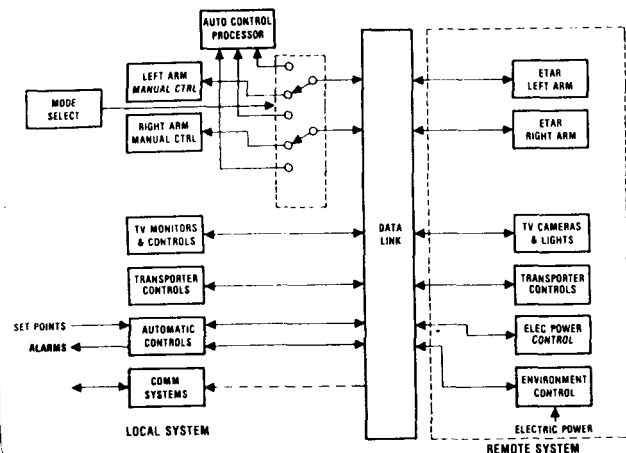

Figure 2. ETAR Complete Control System

## APPLICATIONS TO PAYLOAD TENDING

The ETAR manipulator has two major applications in user payload tending: planned payloads and advanced missions.

## PLANNED PAYLOADS

A Rockwell statistical analysis of the NASA/SSP mission requirements data base suggests that ETAR would be useful in servicing the payloads identified in Table II. Tasks include consumables replacement, specimen change out, and cleaning sensors and reflectors. Tasks will be scheduled routinely and performed by assisting the EVA astronaut or by the ETAR alone, producing significant EVA time savings.

Table II. ETAR Tasks for Planned Payloads

Mission Code	Payload Name	ETAR Task
SAAX 0001	Cosmic ray nuclei experiment	Change out pressurized gas bottle
SAAX 030	Space Station Hitchhiker 1	Change out equipment can
SAAX 207C	High-resolution telescope and spectrograph	Replace film cassette
SAAX 207E	Solar ultraviolet spectral irradiance monitor	Replace inert gas bottle
TDMX 2011	Spacecraft materials and coatings	Change out specimen tray
TDMX 2441	Microelectronics data systems experiment	Change out black boxes
SAAX 4002	Polcats (Canada)	Clean sensors
COMM 4001	Solar cells (Canada)	Replace solar panels

## ADVANCED MISSIONS

We have identified several ETAR applications for advanced, yet to be determined, user missions. Two concepts are the payload farm and batch processing facility.

## Payload Farm

The payload farm concept requires the ETAR to be mounted to a carriage transporter that travels on a fixed track attached to the Space Station truss (Figure 3). Two or more rows of payload hosting bars, each capable of hosting a number of payloads, are in close proximity to the track. The bars provide support, convenient location, and any required power or utilities to the rows of payloads. The end of the track leads to an airlock through which the ETAR and carriage can enter and exit an IVA area for service.

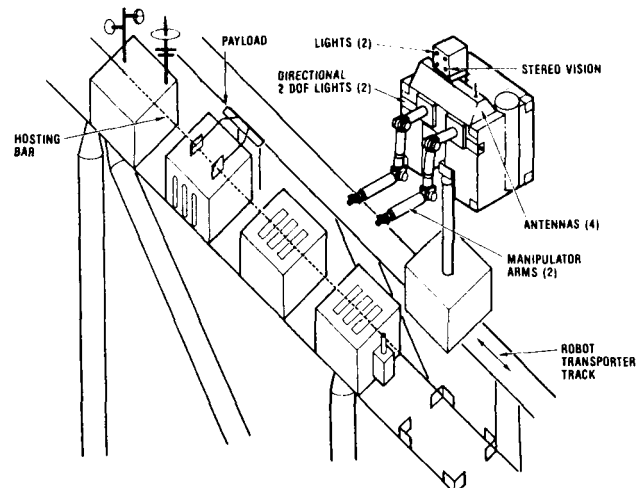

Figure 3. Concept for ETAR Payload Tending

Payloads are separate and discrete, perhaps each belonging to a different commercial user. However, they adhere to rigorous standards regarding size, shape, mass, and connectors and interface with the ETAR end effector. The ETAR can, therefore, be programmed to repeat the same service tasks on each payload (for example, payload change out). The interior of the payload can then remain proprietary to its owner—an attractive feature for commercial users.

#### Batch Processing Facilities

The Space Station may also house batch processing facilities in which operations are analogous to earthbound chemical plants where humans perform similar operations on batteries of production tanks (pharmaceutical production, wine making). ETAR places raw materials in the user production facilities, performs any required service, and later retrieves the finished products. This concept realizes significant EVA crew time savings and enhances the role of the Space Station as a commercial facility for multiple batches.

#### CONCLUSIONS

From the information developed in this study, an effective teleoperated manipulator system for application on and around the Space Station can be developed with a minimum extension to the state-of-the-art technology. The ETAR can perform many of the routine tasks now being performed by EVA astronauts and assist the EVA astronaut in performing extensive tending tasks.

In developing the preliminary concept design of the ETAR manipulator system, existing teleoperated systems were reviewed and found to lack many attributes and capabilities we feel are necessary for a space-based system. In most cases, this lack of space compatibility is understandable due to the fact that the systems were conceived for earthbound application. The ETAR arm, however, should prove to be an invaluable Space Station asset because it will have been specifically designed to assist in Space Station operations.

#### SUMMARY

The work presented above represents the preliminary conceptual design of a teleoperated manipulator system specifically designed for use on a spacecraft such as the Space Station. A number of anticipated Space Station tasks were evaluated to establish the requirements of the system. The system is designed to be controlled predominantly by an IVA astronaut in the Space Station shirt-sleeve environment. The slave arms of the system are located

outside the station and will be of valuable assistance in payload tending tasks, enhancing the commercial role of the Space Station.

#### REFERENCES

1. Clarke, M.M., M.A. Bronez, W.M. Thompson, and M.T. Gibbons, *Orbital Equipment Transfer Techniques, Final Report, Task 1*, Rockwell International, Space Station Systems Division, Downey, California, SSS 85-0095, September 1985.
2. Clarke, M.M. and M.A. Bronez, "Telerobotics for the Space Station," *Mechanical Engineering*, February 1986, pp. 66-72.
3. Bronez, M.A., M.M. Clarke, and A. Quinn, *Requirements Development for a Free Flying Robot — The ROBIN*, Proceedings of IEEE Conference on Robotics and Automation, San Francisco, California, April 1986.
4. Quinn, A., M.M. Clarke, W.M. Thompson, and N. Shields, *A Robot Device for Orbital Equipment Transfer*, Proceedings of SME Robots 10 Conference, Chicago, Illinois, April 1986, pp. 5-99 to 5-108.
5. Bronez, M.A., M.M. Clarke, and A. Quinn, *A Telerobot for Space Station Orbital Equipment Transfer*, Proceedings of Second World Conference on Robotics Research, Scottsdale, Arizona, August 1986.
6. Clarke, M.M., W.M. Thompson, and C. J. Divona, *Requirements and Conceptual Design of the Manipulator System for the Extravehicular Teleoperator Assist Robot (ETAR)*, Rockwell International, Space Station Systems Division, Downey, California, SSS 86-0139, November 1986.
7. Rosheim, M.E., *Four New Robot Wrist Actuators*, Proceedings of SME Robots 10 Conference, Chicago, Illinois, April 1986, pp. 8-1 to 8-45.
8. Corker, K. and A.K. Bejczy, *Recent Advances in Telepresence Technology Development*, Proceedings of Twenty-Second Space Congress, Cocoa Beach, Florida, April 1985.
9. Divona, C.J., W.M. Thompson, A. Quinn, and M.M. Clarke, *A Teleoperator for On-Orbit Manipulation*, Proceedings of International Topical Meeting on Remote Systems Pasco, Washington, April 1987.