

—APPLICATION OF HOFFMAN MODULATION CONTRAST MICROSCOPY COUPLED WITH  
THREE-WAVELENGTH TWO-BEAM INTERFEROMETRY TO THE *IN SITU* DIRECT  
OBSERVATION OF THE GROWTH PROCESS OF A CRYSTAL IN MICROGRAVITY—

Katsuo Tsukamoto

Faculty of Science, Tohoku University  
Aoba, Sendai 980, JAPAN

ABSTRACT

Direct visualization of three-dimensional transfer processes of both heat and mass around a growing crystal and mono-molecular growth layers on the surface is possible *in situ* by means of high resolution Hoffman modulation contrast microscopy (HMCM) coupled with three-wavelength two-beam Mach-Zehnder interferometry (TTMI). This *in situ* observation is very suitable for the verification of the growth mechanism of a crystal in a solution or a melt in microgravity.

## Crystal growth process.

Crystal growth proceeds when molecules are integrated at the surface *via* the transport of molecules from the bulk solution to the crystal surface, at which latent heat would be released at the same time.

Observation of the crystal surface has been one of the most powerful ways to investigate the integration mechanism of molecules at the surface. This has been achieved by means of special optical microscopies like phase contrast microscopy or electron microscopy using decoration techniques. However, these observations were limited to the crystal which has been taken out of the solution, followed by a special surface treatment. If one could directly observe the movement of mono-molecular growth steps *in situ*, it would contribute to investigation of the fundamental growth mechanism of a crystal in more detail. Based upon this ideal, a high-resolution *in situ* observation method was developed by the author in 1983, although there had been several other *in situ* observations with much less resolution. This made it possible to visualize the movement of mono-molecular growth steps with 1.4 nm height on a crystal growing in aqueous solutions, as shown in fig. 1. This method was recently extended to the growth of a crystal in a solution at elevated temperatures as high as 1800 °K.

The transport of molecules is another important problem which has not fully been understood yet, since very complex convections easily appear near the crystal in gravity, which thus disturbs the transport of molecules. The same holds for the transport mechanism of the latent heat which is released during the growth of the crystal. There have been many attempts to measure the concentration gradient around a growing crystal by the Schlieren method or interferometries. However, the transport of heat has not been measured exactly except in a few experiments, in which they put the array of very thin thermocouples normal to the crystal surface for the measurement. The visualization of the heat transfer around a growing crystal is more difficult and thus few experiments have been performed up to now.

So far, experiments on the transfer problem were carried out in the system in which either heat transfer or mass transfer is negligible, although in actual crystal growth processes, both are important. More interesting is their mutual interactions due to the completely opposite direction of the transfer of the heat and the mass. This is believed, in gravity, to cause complex fluctuating flows near the crystal surface, leading to periodic fluctuation of the growth rate, or periodic impurity incorporation into the crystal. This interaction has not yet been investigated, first because of its complex nature for theory, and second because of lack of a suitable experimental method. Since these phenomena (movement of growth layers and the transport of mass and heat) have the mutual interactions, it would be necessary to investigate all phenomena at the same time by an *in situ* method, because these phenomena are not time-stationary.

## Observation in gravity.

Direct observation of both crystal surface and the mass transport phenomena in gravity for the case of aqueous solution growth have been extensively investigated in our group, although heat transfer has not been investigated. The result is summarized as follows.

When the supersaturation is very low,  $< 0.5\%$ , no convection appears and thus the crystal is surrounded by a diffusion boundary layer, fig. 2a. On increasing the supersaturation, a solutal convection plum starts to develop, fig. 2b, due to the large concentration gradient in the diffusion layer, the critical supersaturation of which is typically 1 - 2%. Since the plum develops intermittently and is unstable, the dispersion of the growth rate of a crystal in this range is very large,  $\sim 40\%$ , which would give rise to periodic growth striations even if the bulk supersaturation is accurately controlled,  $< 0.01\%$ . This unstable plum disappears when the supersaturation is increased further, which is followed by the development of a stable plum, fig. 2c. This again stabilizes the growth rate of a crystal. It may be important to note that the supersaturation range, 1 - 2%, is often used to grow large crystals in solutions without considering the hydrodynamical behavior of the convections.

The development of this kind of solutal convection influences not only the growth rate of a crystal versus supersaturation, fig. 3, but also the surface state of a crystal, fig. 4. When the surface of a crystal

which was grown at, for instance 5%, is observed *in situ*, many inclusions are observed to be trapped on the surface. It is interesting to see that they are trapped along the periphery of the root of a convection plumb. As the plum position shifts, the array of inclusions also shifts.

Although this is one of the examples to show that hydrodynamical properties of the solution around a crystal have many influences on the growth kinetics and the perfection of a crystal, numbers of *in situ* observations have already been performed during the past several years and thus, enough data are available for comparison with the experiments in microgravity. It is proposed here to perform similar *in situ* direct observations of a crystal growth process in microgravity, so that one can find out the essential difference between growth mechanisms in gravity and in microgravity in much more direct ways. Such high resolution *in situ* observations as proposed here were developed in Japan for use in gravity, but have not yet been proposed in any countries for use in microgravity. If this kind of *in situ* visualization of the phenomena were performed together with the coupled kinetical measurements, it would have wider applicability in other material sciences in microgravity.

### Proposed experiment.

#### 1. Crystal

Several solution-grown or melt-grown crystals will be selected from inorganic and organic crystals; the saturation temperatures and the melting temperatures are 40 - 50 °C. By varying the chemical composition, some crystals are grown as faceted, which are suitable for the direct observation of layer growth on the surface and the mass and heat transport phenomena. The other crystals are grown as dendrites, which are suitable for the visualization of the heat and mass transfer process and the mutual interaction. Needless to say, experiments both in gravity and in microgravity are necessary for the analysis of the growth mechanism.

#### 2. Optical system

Hoffman modulation contrast microscopy (HMCM) with the auto-focusing system is selected among varieties of microscopes because of its high contrast images for both isotropic and anisotropic crystals, by which growth layers as thin as 1 nm can be resolved, fig. 5. In order to visualize the mass and heat transfer process around a growing crystal quantitatively, three-wavelength two-beam Mach-Zehnder interferometry is used (fig. 5). The optical pass and the lenses are almost in common with HMCM. The resolution of the interferometry has much higher resolution than holographic interferometries if it is adjusted correctly. In order to avoid the problem of heat radiation and the electric energy consumption, LEDs with three different colors are used, which are switched on alternatively, in order to increase the S/N ratio of the optical images by reducing the background intensity of the scattering light in a crystal. These are synchronized with the CCD TV camera for recordings. The interference fringes from three different wavelengths and the HMCM images are recorded on video tape.

So as to obtain the three-dimensional information on the heat and mass transfer, two vertically-crossing optical axes will be used.

#### 3. Growth cell.

A crystal is grown in a growth cell, the temperature of which is controlled by thermo-modules with the temperature stability of < 1.0 °C. The cell is made of an aluminum block, fig. 6, in which a degasser is used to remove possible air bubbles in the solution, a solution pump and thermo-modules are installed.

Six growth cells are prepared to be exchanged for the observation of different crystals.

Since a seed crystal is used, a remote monitor is used to see its shape through TV images. This is necessary so as not to dissolve the seed crystal completely just before the growth experiments.



Fig. 1 SPIRAL STEP WITH 1.4 nm HEIGHT OF  $\text{CdI}_2$  GROWING IN AN AQUEOUS SOLUTION, BY *IN SITU* OBSERVATION, FROM TV

ORIGINAL PAGE IS  
OF POOR QUALITY

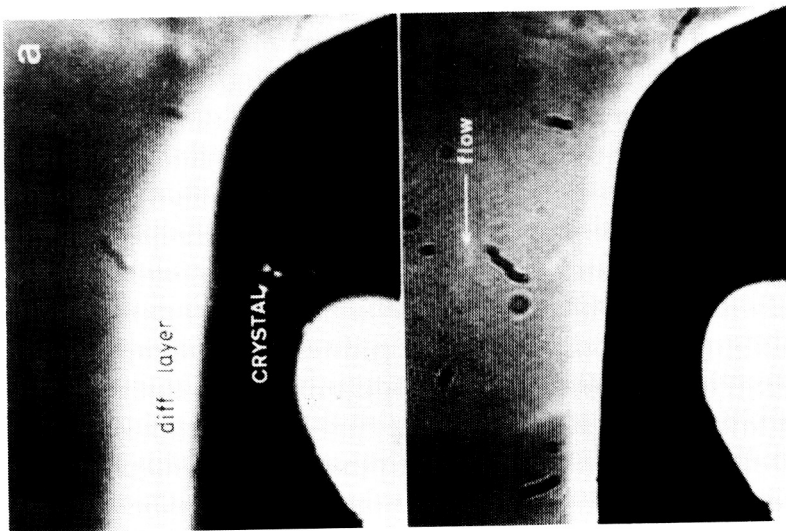
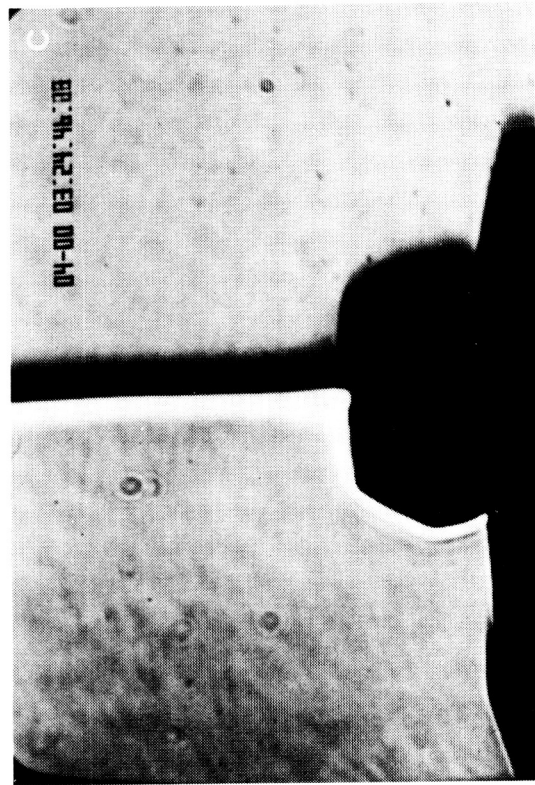
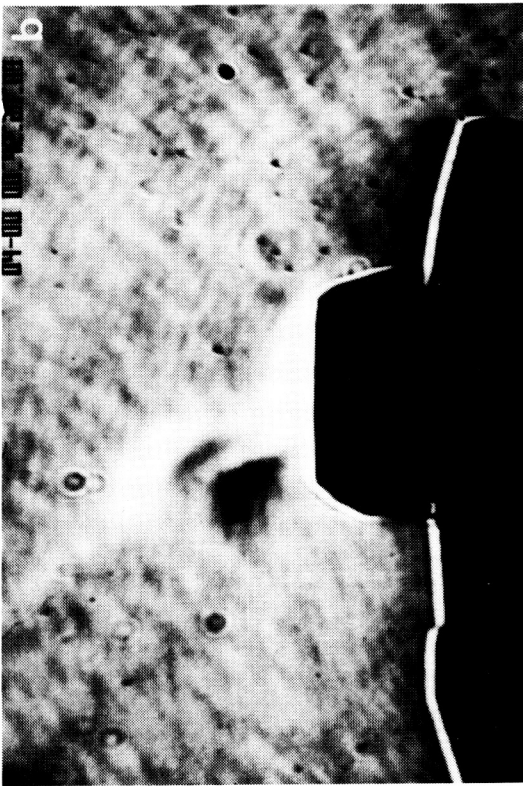

Fig. 2 DEVELOPMENT OF A CONVECTION PLUM  
ON INCREASING THE SUPERSATURATION  
OF THE SOLUTION, SCHLIEREN IMAGE,  
(a) < 0.5%, (b) 2%, and (c) 7%,  $\text{Ba}(\text{NO}_3)_2$

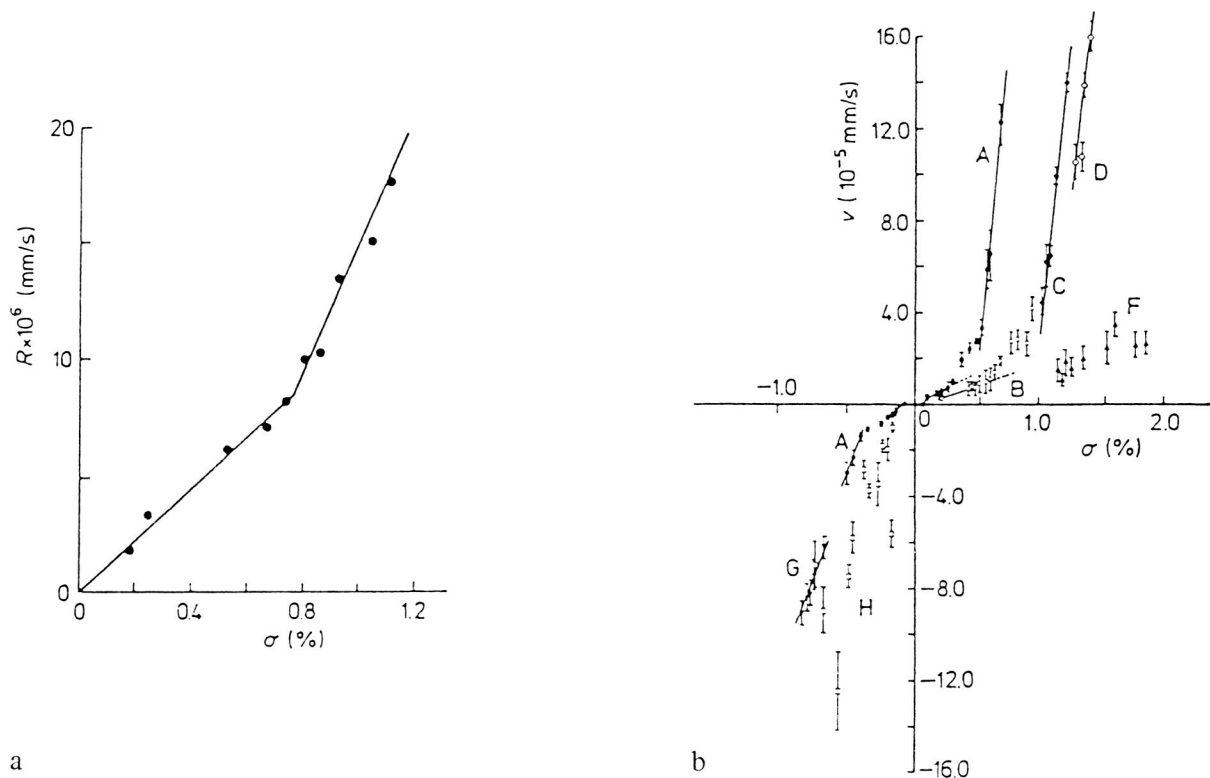

Fig. 3 (a) GROWTH RATE VS SUPERSATURATION, AND (b) ADVANCE RATE OF GROWTH LAYERS VS SUPERSATURATION,  $\text{Ba}(\text{NO}_3)_2$ . NOTE THE LARGER SLOPE WHEN A PLUM APPEARS.

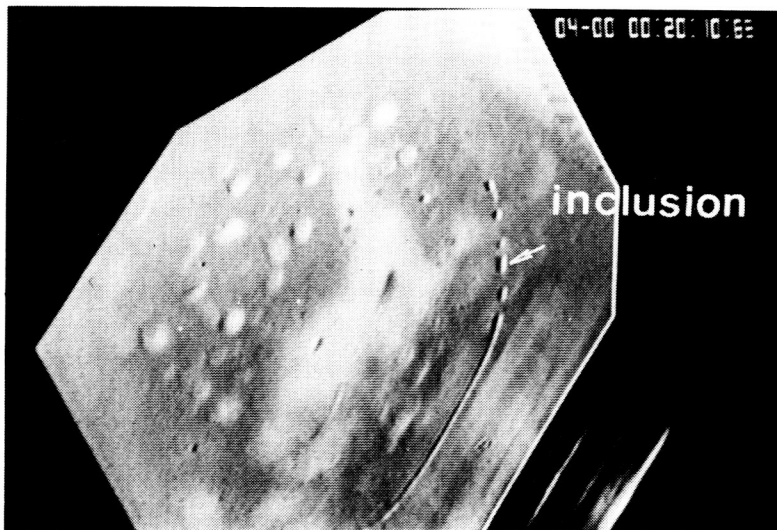

Fig. 4. TRAP OF INCLUSIONS DUE TO THE DEVELOPMENT OF A CONVECTION PLUM. THE DISTRIBUTION OF THE INCLUSIONS IS LARGELY INFLUENCED BY THE PATTERN OF A CONVECTION PLUM. THE DEVELOPMENT OF DISLOCATIONS IS ALSO INFLUENCED BY THE CONVECTION.

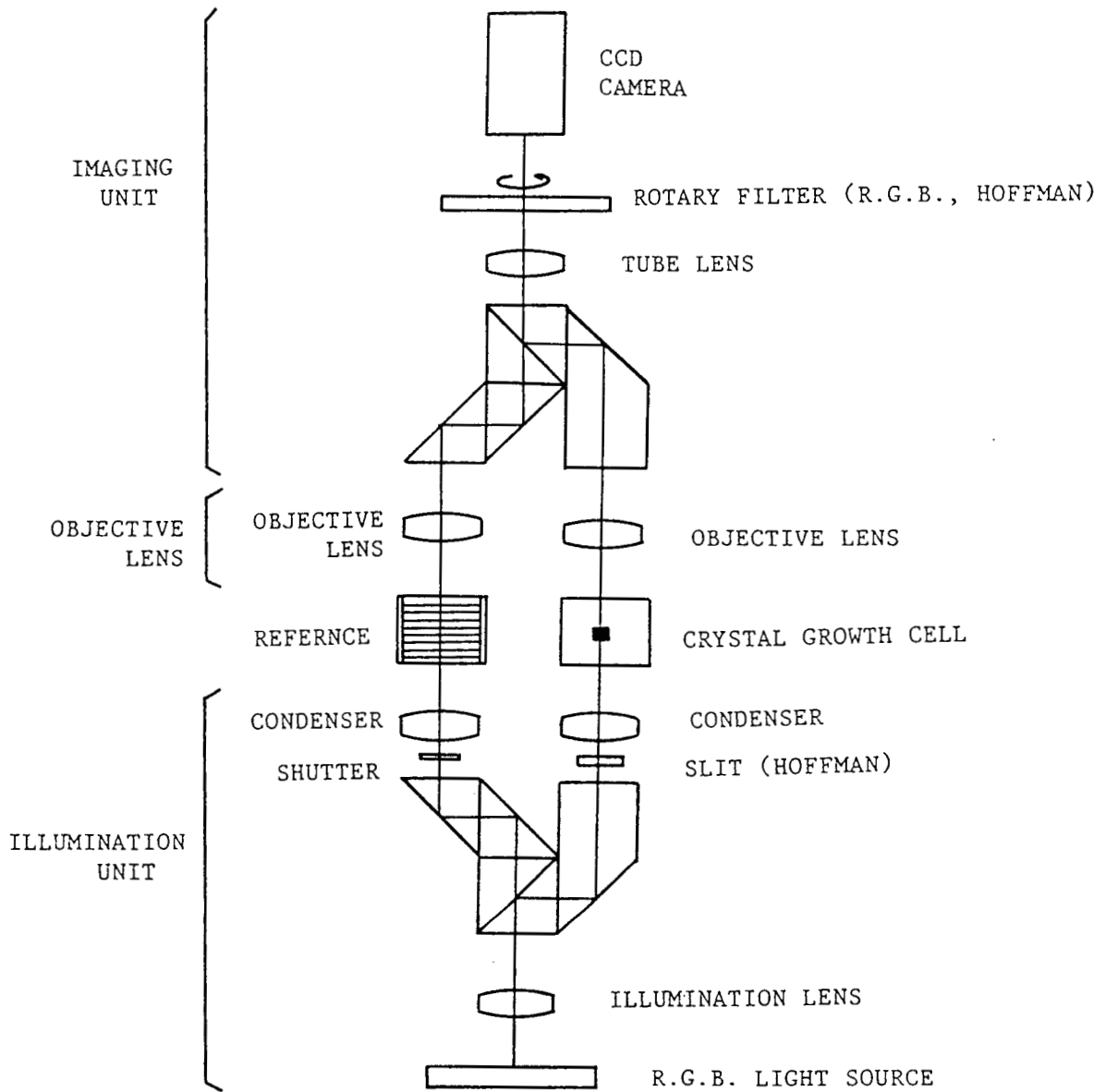

Fig. 5. HOFFMAN MODULATION CONTRAST MICROSCOPY COUPLED WITH THREE-WAVELENGTH, TWO-BEAM INTERFEROMETRY

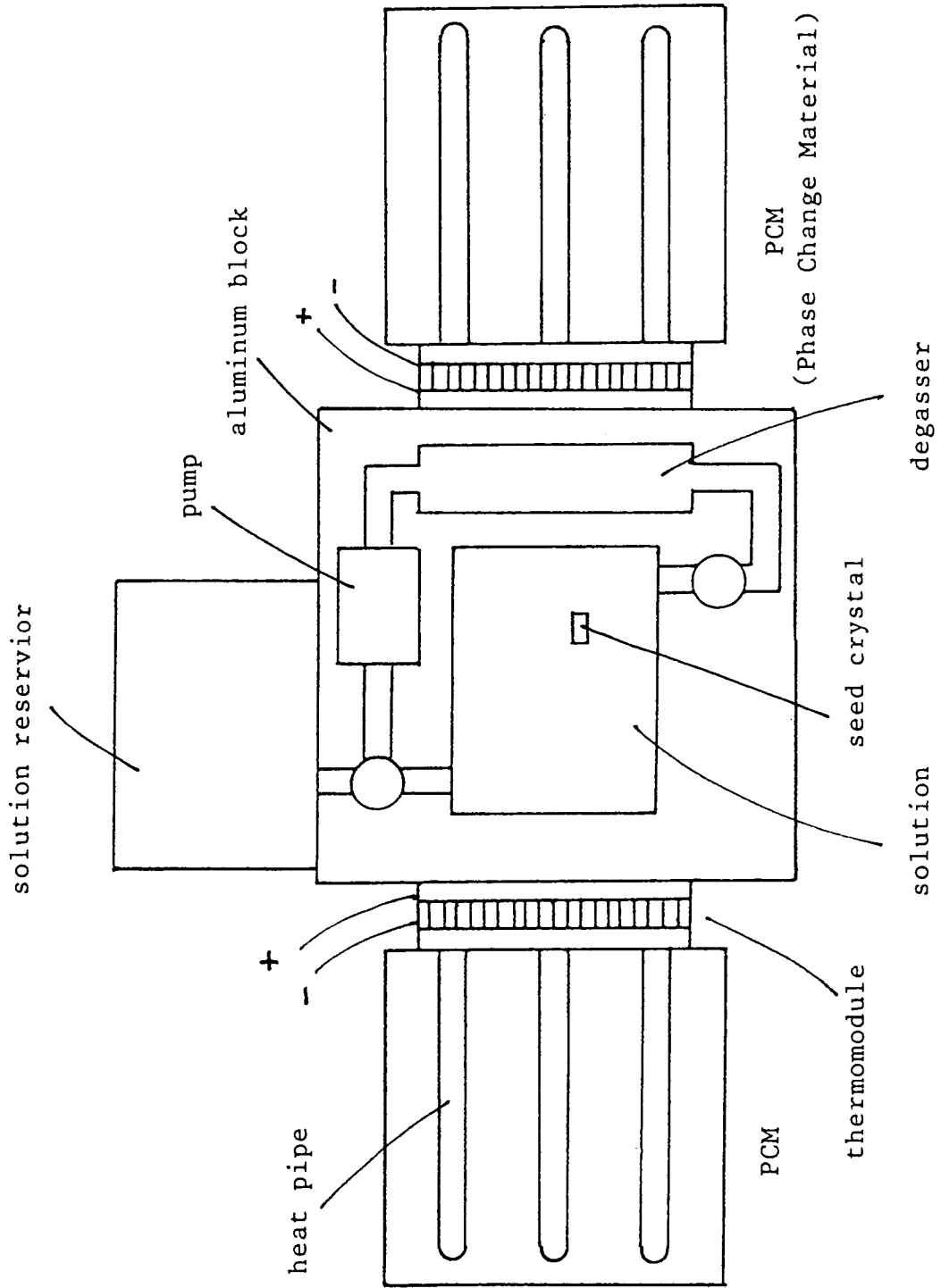
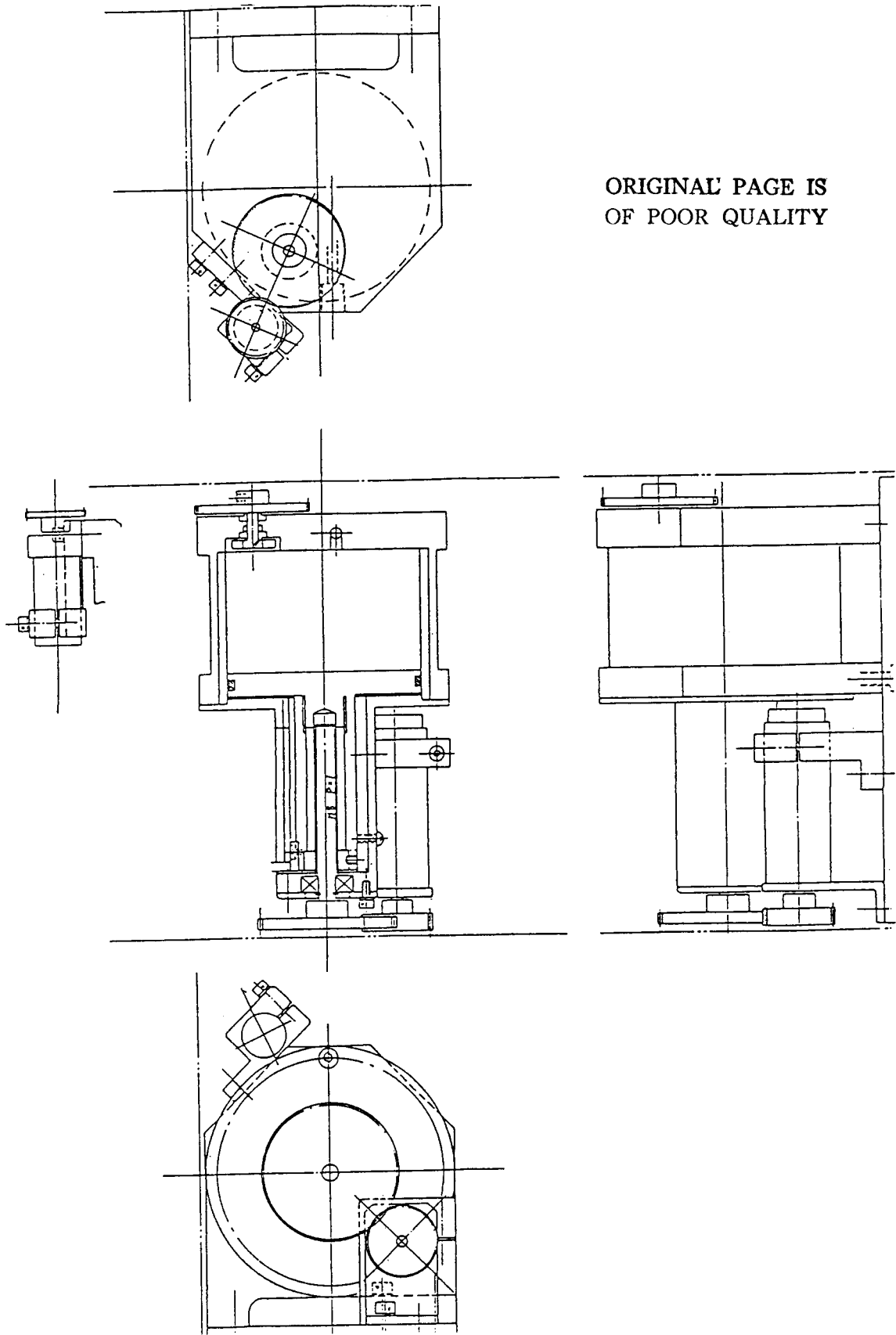

Fig. 6a. THE PRINCIPAL OF THE GROWTH CELL





ORIGINAL PAGE IS  
OF POOR QUALITY

Fig. 6b. THE SOLUTION RESERVOIR, IN WHICH THE SOLUTION IS STORED PRIOR TO THE GROWTH EXPERIMENT

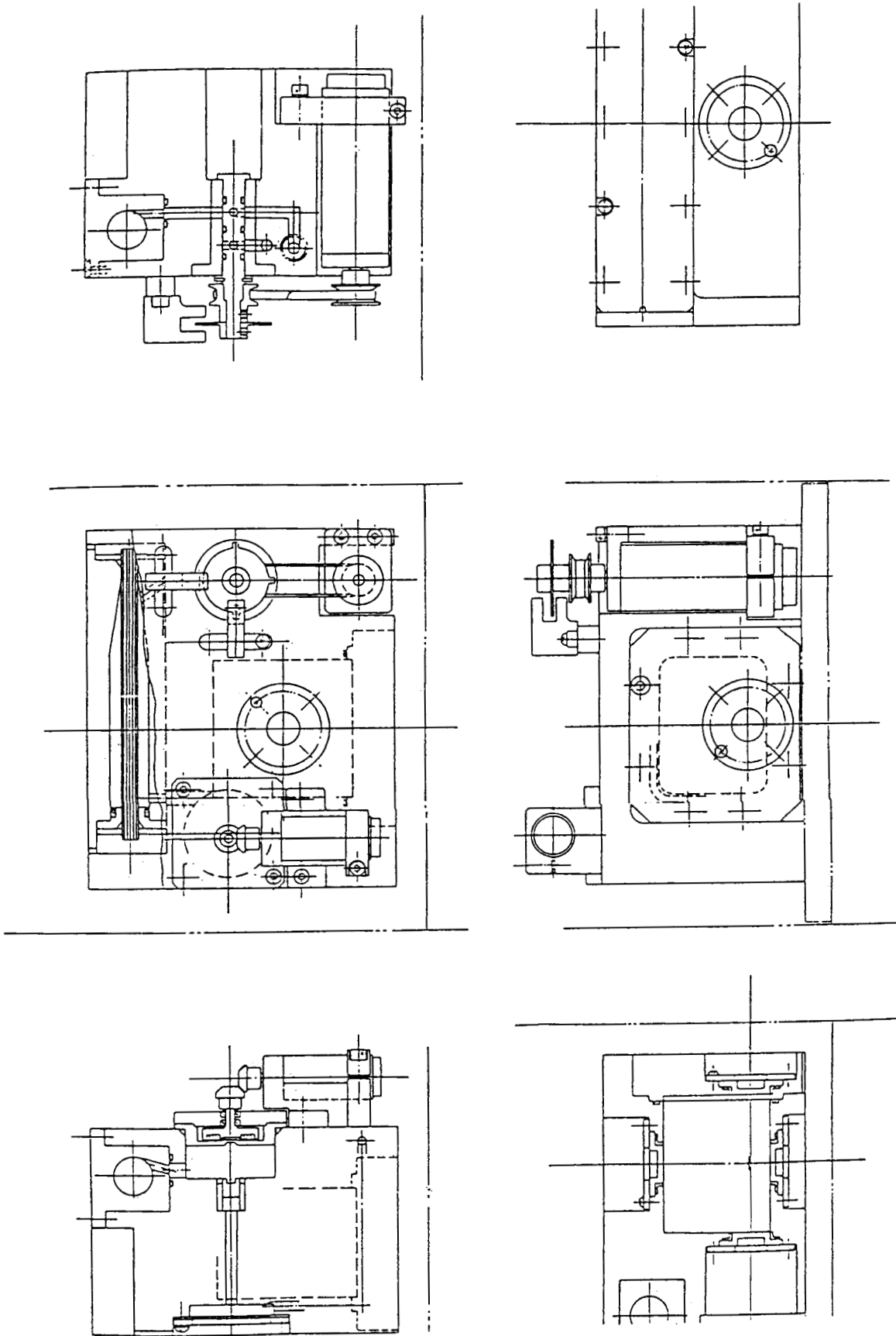

Fig. 6c. THE GROWTH CELL, IN WHICH A SOLUTION PUMP, A DEGASSER, OBSERVATION WINDOWS AND A SEED CRYSTAL ARE INSTALLED