

# NASA Contractor Report 4114

## Preliminary Analysis of an Integrated Logistics System for OSSA Payloads

T. Palguta, W. Bradley,  
and T. Stockton

CONTRACT NAS8-32697  
FEBRUARY 1988

(NASA-CR-4114) PRELIMINARY ANALYSIS OF AN  
INTEGRATED LOGISTICS SYSTEM FOR OSSA  
PAYLOADS Final Contractor Report, 15 Sep.  
1986 - 15 Apr. 1987 (Lockheed Missiles and  
Space Co.) 104 p

N88-19477  
--THRU--  
N88-19481  
Unclas  
CSCL 22A H1/12 0124527

The NASA logo, consisting of the word "NASA" in a bold, sans-serif font.

NASA Contractor Report 4114

# Preliminary Analysis of an Integrated Logistics System for OSSA Payloads

T. Palguta, W. Bradley,  
and T. Stockton

*Lockheed Huntsville Engineering Center  
Huntsville, Alabama*

Prepared for  
George C. Marshall Space Flight Center  
under Contract NAS8-32697



National Aeronautics  
and Space Administration

Scientific and Technical  
Information Division

1988

## FOREWORD

The NASA Office of Space Science and Applications Logistics Study was initiated on September 15, 1986 and completed on April 15, 1987. The study was conducted by Lockheed Missiles & Space Company, Huntsville Engineering Center, Huntsville, Alabama. The Study Manager was Dr. John D. Hilchey, NASA Marshall Space Flight Center. The study results described in this document are subdivided into the following four volumes:

- Volume I: Executive Summary
- Volume II: OSSA Integrated Logistics Support Strategy
- Volume III: OSSA Integrated Logistics Support Planning Document
- Volume IV: Supportability Analysis of the 1.8 M Centrifuge

## TABLE OF CONTENTS

	<u>Page</u>
VOLUME I. EXECUTIVE SUMMARY.....	1
1.0 INTRODUCTION .....	3
1.1 Background .....	3
1.2 Scope .....	5
2.0 OSSA INTEGRATED LOGISTICS SUPPORT STRATEGY .....	8
2.1 General .....	8
2.2 Objectives .....	9
2.3 Organization .....	9
2.4 Implementation .....	11
2.5 Commonality .....	11
3.0 OSSA INTEGRATED LOGISTICS SUPPORT PLANNING DOCUMENT .....	17
3.1 General .....	17
3.2 Procedures .....	17
3.3 Content .....	18
4.0 SUPPORTABILITY ANALYSIS OF THE 1.8 M CENTRIFUGE .....	19
4.1 General .....	19
4.2 Reliability .....	19
4.3 Maintainability .....	20
4.4 Commonality .....	21
5.0 SUMMARY .....	22
5.1 General .....	22
5.2 Future Needs .....	23
VOLUME II. OSSA INTEGRATED LOGISTICS SUPPORT STRATEGY .....	25
1.0 INTRODUCTION .....	27
1.1 Purpose .....	27
1.2 Scope .....	27
2.0 LOGISTICS STRATEGY .....	28
2.1 General .....	28
2.2 Objectives .....	29
2.3 Organization .....	29
3.0 IMPLEMENTATION .....	33
3.1 General .....	33
3.2 Phase I .....	34
3.3 Phase II .....	36
3.4 Phase III .....	36
4.0 COMMONALITY .....	38
4.1 General .....	39
4.2 Integrated Logistics Support Plan (ILSP) .....	39
4.3 Logistics Information System (LIS) .....	42
4.4 Repair Level Analysis (RLA) .....	47

TABLE OF CONTENTS (Continued)

	<u>Page</u>
VOLUME II. (Continued)	
4.5 Repair Parts Screening .....	48
4.6 Source, Maintenance, and Recoverability (SMR) Coding .....	48
4.7 Technical Data Packages .....	51
4.8 Facilities .....	51
4.9 Packaging Handling, Storage and Transportation (PHS&T) ...	53
4.10 Operational Cost Model .....	53
5.0 SUMMARY .....	57
GLOSSARY .....	58
VOLUME III. OSSA INTEGRATED LOGISTICS SUPPORT PLANNING DOCUMENT .....	
1.0 INTRODUCTION .....	65
1.1 Purpose .....	65
1.2 Scope .....	65
2.0 ILS OVERVIEW .....	66
2.1 Definition .....	66
2.2 ILS Policy .....	66
2.3 ILS Objectives .....	67
3.0 ILS PROCEDURES .....	68
3.1 Development .....	68
3.2 Implementation .....	68
3.3 Description .....	68
3.4 Time Phasing .....	69
4.0 ILSP CONTENT .....	70
4.1 Organization .....	70
4.2 Content of Section I - General .....	72
4.3 Content of Section II - Plans, Goals, and Strategy .....	73
4.4 Content of Section III - ILS Milestone Schedule .....	77
4.5 Annexes .....	79
GLOSSARY .....	80
VOLUME IV. SUPPORTABILITY ANALYSIS OF THE 1.8 M CENTRIFUGE .....	
1.0 INTRODUCTION .....	87
1.1 Purpose .....	87
2.1 Scope .....	87
2.0 OBJECTIVES AND REQUIREMENTS .....	89
2.1 Objectives .....	89
2.2 Requirements .....	89

TABLE OF CONTENTS (Concluded)

	<u>Page</u>
VOLUME IV. (Continued)	
3.0 SUPPORTABILITY ISSUES .....	94
3.1 General .....	94
3.2 Reliability .....	94
3.3 Maintainability .....	97
3.4 Commonality .....	98
4.0 SUMMARY .....	100

LIST OF ILLUSTRATIONS

<u>Figure</u>	<u>Title</u>	<u>Page</u>
VOLUME I. EXECUTIVE SUMMARY		
1-1.	Logistics Study Flow and Schedule .....	6
2-1.	Logistics Organization .....	10
2-2.	ILS Strategy Implementation Ohases .....	12
2-3.	Logistics Information System (LIS) Components .....	14
VOLUME II. OSSA INTEGRATED LOGISTICS SUPPORT STRATEGY		
2-1.	Logistics Organization .....	30
3-1.	ILS Strategy Implementation Phases .....	35
4-1.	Commonality Program Interface .....	40
4-2.	Logistics Information System (LIS) Components .....	43
4-3.	LSAR Inputs/Outputs .....	45
4-4.	Repair Level Analysis Process .....	49
4-5.	Source, Maintenance, and Recoverability (SMR) Codes .....	50
4-6.	Facility Functions .....	52
4-7.	PHS&T Process .....	54
4-8.	Operations and Support Cost .....	56
VOLUME III. OSSA INTEGRATED LOGISTICS SUPPORT PLANNING DOCUMENT		
4-1.	Typical Integrated Logistics Support Schedule .....	78
VOLUME IV. SUPPORTABILITY ANALYSIS OF THE 1.8 M CENTRIFUGE		
2-1.	Drawing of 1.8 M Centrifuge .....	90
3-1.	Schematic of 1.8 M Centrifuge .....	95
3-2.	Series Relationship .....	96

LIST OF TABLES

<u>Table</u>	<u>Title</u>	<u>Page</u>
	VOLUME III. OSSA INTEGRATED LOGISTICS SUPPORT PLANNING DOCUMENT	
4-1.	Logistics Support Analysis Tasks .....	74
	VOLUME IV. SUPPORTABILITY ANALYSIS OF THE 1.8 M CENTRIFUGE	
2-1.	System Requirements .....	91
2-2.	Requirements Imposed By Science Users .....	92
2-3.	Science Requirements .....	92
2-4.	Design Requirements Imposed By SSP .....	93
3-1.	Component/System MTBF .....	96



## LIST OF ACRONYMS

ARC	Ames Research Center
BIT	Built-in Test
BITE	Built-in Test Equipment
DLSC	Defense Logistics Services Center
DoD	Department of Defense
ECLSS	Environmental Control and Life Support System
EOQ	Economic Order Quantity
FMEA	Failure Modes and Effects Analysis
G	Gravity
GSE	Ground Support Equipment
HEC	Huntsville Engineering Center
HST	Hubble Space Telescope
ILS	Integrated Logistics Support
ILSMT	Integrated Logistics Support Management Team
ILSP	Integrated Logistics Support Plan
ILWG	Integrated Logistics Working Group
IM	Intermediate Maintenance
IMS	Inventory Management System
JSC	Johnson Space Center
LCC	Life Cycle Cost
LIS	Logistics Information System
LMIS	Logistics Management Information System
LMSC	Lockheed Missiles and Space Company
LSA	Logistics Support Analysis
LSAR	Logistics Support Analysis Record
M	Meter

## LIST OF ACRONYMS (Concluded)

MH	Man-hour
MTBF	Mean Time Between Failure
MTBM	Mean Time Between Maintenance
MTRR	Mean Time to Repair
NASA	National Aeronautics and Space Administration
NHA	Next Higher Assembly
NIIN	National Item Identification Number
NMI	NASA Management Instruction
ORU	Orbital Replaceable Unit
O&S	Operations and Support
OSSA	Office of Space Science and Applications
PDRD	Program Definition and Requirement Document
PHS&T	Packaging, Handling, Storage and Transportation
RAM	Reliability, Availability, and Maintainability
RLA	Repair Level Analysis
SMR	Source, Maintenance, and Recoverability
SRA	Support Requirements Analysis
SSP	Space Station Program
STS	Space Transportation System
TMDE	Test, Measurement, and Diagnostic Equipment
TMIS	Technical Management Information System

S1-12  
124528  
22P.

PRELIMINARY ANALYSIS  
OF AN  
INTEGRATED LOGISTICS SYSTEM  
FOR  
OSSA PAYLOADS

N88-19478

Volume I  
Executive Summary

T. Palguta, W. Bradley and T. Stockton

Lockheed  
Huntsville Engineering Center

Contract Number NAS8-32697

April 1987

George C. Marshall Space Flight Center  
National Aeronautics and Space Administration  
Huntsville, AL 35812

## 1.0 INTRODUCTION

### 1.1 BACKGROUND

The OSSA Logistics Study commenced in September 1986 with the following tasks: (1) provide a preliminary estimate of the logistics support requirements for OSSA payloads in the Space Station era; and (2) outline an OSSA logistics planning and management system that will provide the required logistics support. Recognition of the importance of logistics to OSSA payloads resulted in the initiation of this study. The importance of logistics centered not only on the ability to support the payloads, but also on being able to afford to support the payloads. Logistics must consider both supportability and affordability. In the past, OSSA payloads did not have to consider support costs. Once they were launched, there was essentially no way to get at them for repair or refueling. In the Shuttle era, payloads are designed for on-orbit maintenance and servicing. Space Station will augment on-orbit support capabilities. Logistics support costs have become a consideration for all OSSA payloads. Historically, operations and support costs have ranged from 40-60% of life-cycle cost for a typical system. Using HST as an example, the operations and support costs are estimated to be \$150 million per year. This figure represents 10% of OSSA's current budget. This is just for operating and supporting one payload. This means that the estimated cost for operation and support of HST will amount to 67% of life-cycle costs. With the number of planned OSSA payloads in the Space Station era, affordability becomes the key consideration with logistics

support costs being the driver. This study is the first attempt to come to grips with the logistics support cost burden for OSSA payloads across the board, with special reference to Space Station payloads.

At initiation of this study, a review of other logistics studies was conducted to avoid redundancy with work already completed or underway. The review of other studies revealed that the emphasis had been on determining resupply/return requirements for OSSA payloads in, attached to, or serviced by Space Station. While this information is somewhat useful to Space Station for planning purposes, it does not represent the total OSSA logistics support requirements. The other logistics studies did not address the derived or implied logistics support requirements. The studies identify ORU changeout as a logistics requirement, however, the studies fail to identify the other logistics requirements in the following categories: support equipment; supply support; personnel and training; technical data; packaging, handling, storage and transportation requirements; facilities; and computer resource requirements. The studies focused on identifying the end product without identifying the support pyramid and the system that will provide the support.

The documentation review also consisted of a review of NASA/OSSA level policies, plans, and NMIs. The purpose of the review was to identify any NASA/OSSA logistics policies or plans that would facilitate the development of an OSSA logistics planning and management system. The review of the documentation did not reveal any NASA/OSSA level logistics policies, plans, or guidance.

The initial documentation review set the stage for the study. The major objective of the study was to develop a logistics strategy for OSSA that will lead to the cost effective logistics support of all OSSA payloads. A secondary objective of the logistics study was to develop an OSSA Integrated Logistics Support Planning Document. The purpose of this document was to establish procedures for the preparation of integrated logistics support plans at the OSSA payload program level. This planning document is an initial step in providing logistics guidance to the payload programs.

The approach to the logistics study was briefed to the OSSA Planning Group in November 1986. The approach was endorsed and an additional task was added to the study. The task was to analyze an OSSA payload in development to quantify the benefit of early logistics support analysis in the payload life-cycle. A major subsystem of the Life Science Research Facility, the 1.8 meter centrifuge was chosen as the subject of the analysis. The preliminary supportability analysis of the centrifuge commenced in December 1986 and was completed in March 1987. The preliminary study results were delivered for review in February and March 1987, and the study results were finalized in April 1987. Figure 1-1 shows the logistics study flow and schedule.

## 1.2 SCOPE

The results of the OSSA Logistics Study are documented in the following four volumes:

Volume I - Executive Summary: The purpose of this document is to describe the logistics study background and approach. In addition, the

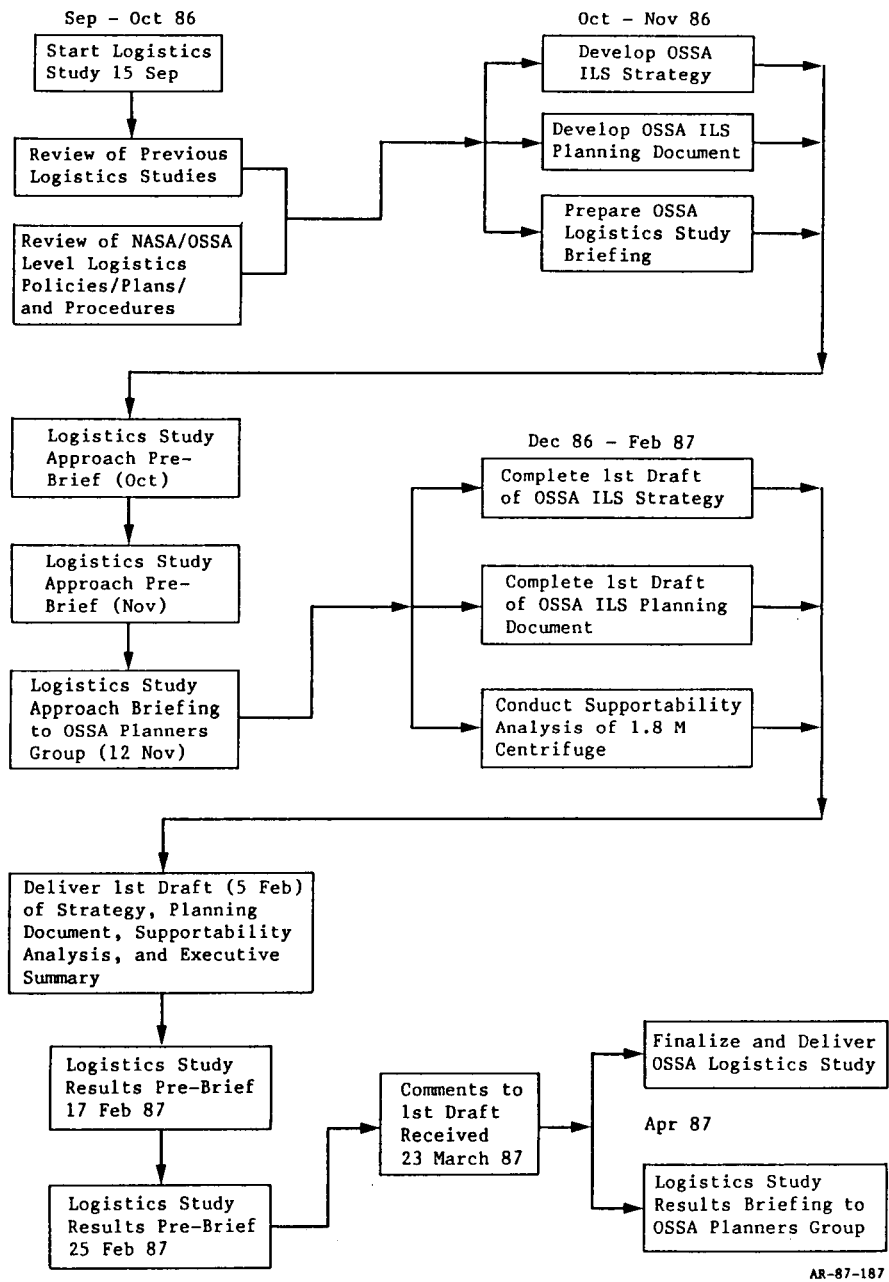

AR-87-187

Fig. 1-1 Logistics Study Flow and Schedule

document provides a concise summary of the study results and identifies future logistics support analysis tasks.

Volume II - OSSA Integrated Logistics Support Strategy: This document defines the OSSA logistics strategy, the methodology for implementing the strategy, and the specific logistics tasks that require study and analysis to support the development of an OSSA Integrated Logistics Support Program.

Volume III - OSSA Integrated Logistics Support Planning Document: This document establishes procedures for the preparation of integrated logistics support plans at the OSSA payload program level.

Volume IV - Supportability Analysis of the 1.8 M Centrifuge: This document addresses supportability issues for the 1.8 M centrifuge in the Life Science Research Facility. The analysis focuses on reliability and maintainability and the potential impact on supportability and affordability.



## 2.0 OSSA INTEGRATED LOGISTICS SUPPORT STRATEGY

### 2.1 GENERAL

The strategy for integrating OSSA logistics requirements will be to establish an OSSA Integrated Logistics Support Program. Full understanding, concise planning, and common policy and direction for OSSA programs are required to achieve a cost and operationally effective integrated logistics support program. Key to establishing a meaningful logistics program is the initial activity involving the development and communication of basic logistics policies, plans and procedures. These activities form the foundation and provide the common guidance for all OSSA Payload Program Managers in the planning, analyzing, designing, and supplying of logistics services and support resources. The resulting active participation and full communication assures the development of effective interfaces and working relationships, a common base of understanding across OSSA, identification and development of the most cost effective approach, and responsive implementation of requirements.

Specific policies, plans and procedures that will be developed to establish an OSSA Integrated Logistics Support Program are summarized in Paragraph 2.5 of this document. The policies, plans, and procedures will be developed through a series of logistics studies and analyses. The results of the studies and analyses will be documented in an OSSA Logistics Plan.

## 2.2 OBJECTIVES

The objectives of the OSSA logistics strategy are as follows:

- a. Minimize system support and life cycle costs for OSSA payloads.
- b. Establish an OSSA integrated logistics system responsive to the support of payload design, development and operations.
- c. Integrate logistics across the various OSSA payload programs to ensure that each payload's logistics requirements can be effectively merged into a single OSSA logistics system.
- d. Assure visibility at OSSA level over all major logistics activities and resources within the payload programs.
- e. Assure that logistics is considered in early design activities to ensure long-term program supportability.
- f. Assure acquisition of only those materials, equipment and services necessary by optimizing the use of existing facilities, equipment, capabilities, and hardware from other programs.
- g. Ensure the timely availability of required equipment, materials, and services within budget limitations.
- h. Assure communication and coordination among OSSA programs, other NASA program offices, and other applicable agencies.

## 2.3 ORGANIZATION

The establishment and implementation of an OSSA Integrated Logistics Support Program will require the establishment of a functional OSSA ILS organization. Figure 2-1 portrays the organizational relationships for management of OSSA logistics activities. General responsibilities for accomplishment of these activities are detailed in the appropriate section of Volume II, OSSA Integrated Logistics Support Strategy.

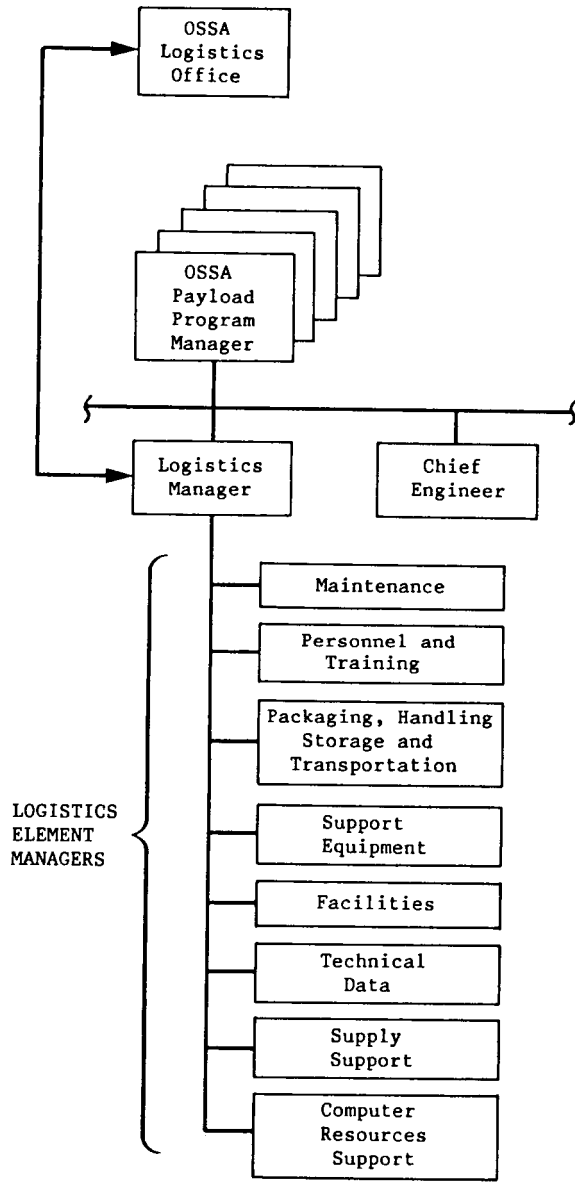

Fig. 2-1 Logistics Organization

## 2.4 IMPLEMENTATION

Implementation of the OSSA logistics strategy will result in the establishment of an integrated logistics support program for OSSA. Implementation of the OSSA logistics strategy will require conducting logistics analyses, identifying standard logistics procedures, sharing and developing logistics support resources, and establishing programs to reduce the demand for logistics support resources. The strategy will be implemented in phases, with the final objective being a standardized, integrated logistics program within OSSA and across all NASA programs. This integrated logistics program will be able to provide optimum logistics support at minimum cost. Details of the phasing are developed in Volume II, OSSA Integrated Logistics Support Strategy. Figure 2-2 shows the phased implementation of the OSSA logistics strategy.

## 2.5 COMMONALITY

The key to development and implementation of an efficient, cost-effective OSSA Integrated Logistics Support Program is the definition and establishment of common logistics policies, plans, procedures and support resources within OSSA and other NASA organizations. Commonality within the OSSA logistics program will start with the development of standard procedures for the Logistics Support Analysis (LSA) of all OSSA payloads.

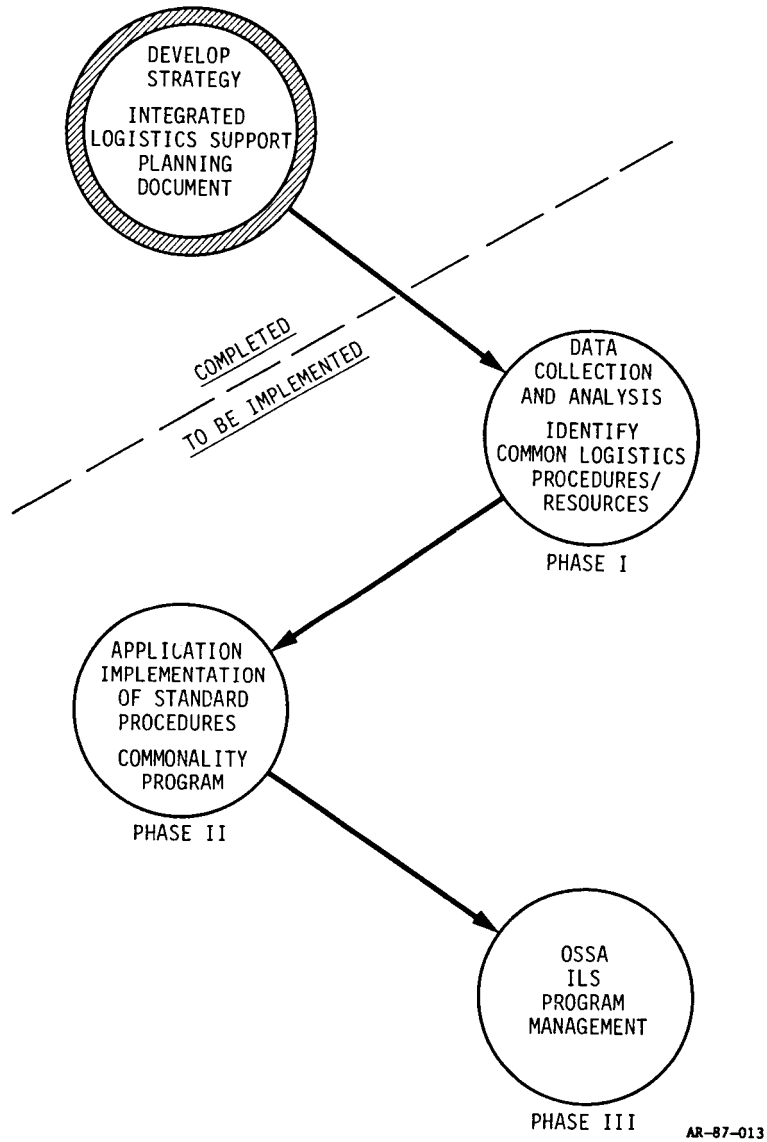

Fig. 2-2 ILS Strategy Implementation Phases

### 2.5.1 Integrated Logistics Support Plans

OSSA will require, and provide guidance for, the preparation of OSSA payload program logistics support plans. In addition, a review loop at OSSA will be established for these plans. OSSA will formulate a policy statement to implement the requirement for these plans. The key logistics document that will be required is the Integrated Logistics Support Plan. This document is prepared at payload program level to provide the common direction and control required to meet the logistical needs of the program. Guidance for preparing this document is contained in Volume III of this study. Subordinate logistics plans that will also be developed include: the maintenance plan; technical data and documentation plan; supply support plan; logistics facilities plan; packaging, handling, storage, and transportation plan; logistics support personnel and training plan; support equipment plan; and the logistics information system plan. Essential features of these plans are described in Volume II, OSSA Integrated Logistics Support Strategy, paragraph 4.2.

### 2.5.2 Logistics Information System (LIS)

The LIS is designed to serve as a comprehensive system which will provide real time status of significant logistics activities to determine and evaluate the supportability of OSSA payload programs. The LIS is the key to the coordination of logistics activities within OSSA. Figure 2-3 shows the elements of the LIS; these are detailed in Volume II, paragraph 4.3.

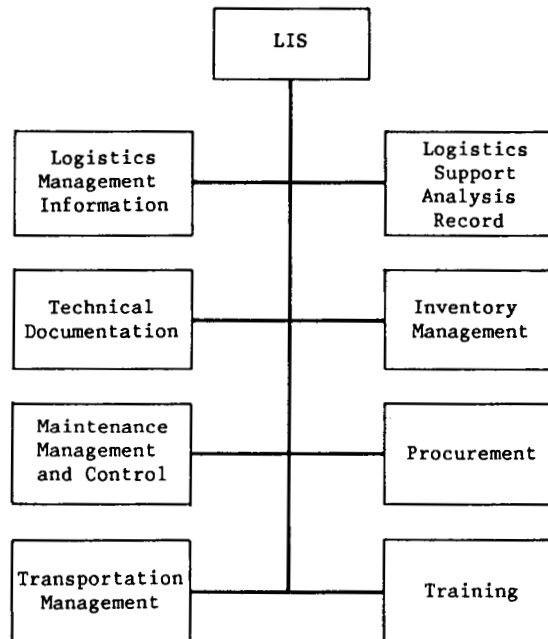

Fig. 2-3 Logistics Information System (LIS) Components

### 2.5.3 Supporting Activities

There are a number of major supporting activities that must be instituted by OSSA to develop the standard logistics procedures that will ensure an efficient, cost-effective OSSA integrated logistics support program. These activities will be developed through a series of logistics studies and analyses, and include:

- o Repair Level Analysis - Establish procedures to determine feasibility and location for repair of ORUs, assemblies, and subassemblies based on life-cycle cost.
- o Repair Parts Screening - Establish procedures to prevent entry of items into the NASA inventory that are available in Government inventories. Establish standard part numbers for comparison/integration purposes.
- o SMR Coding - Establish procedures for the uniform coding of all support items to convey maintenance and supply instructions to the various logistics support levels.
- o Technical Data Packages - Establish procedures for acquisition of required technical data to facilitate repair/refurbishment of support items.
- o Facilities - Establish procedures for identifying required/available logistics support facilities.
- o Packaging, Handling, Storage, and Transportation (PHS&T) Procedures - Establish standard PHS&T procedures that are the most efficient/cost-effective.
- o Operational Cost Modeling - Establish a single standard operational cost model to predict/minimize cost. Facilitates comparison between programs.

The details for the specific activities that will be developed for commonality application are addressed in detail in Volume II, OSSA Integrated Logistics Support Strategy, Section 4. The results of the logistics studies and analyses will be incorporated into a series of OSSA-level logistics plans.



Conducting the appropriate logistics studies and analyses and developing the OSSA-level logistics plans is the next step in developing and establishing an OSSA Integrated Logistics Support Program. The ILS Program will enable OSSA to come to grips with logistics support costs and ensure supportability of all OSSA payloads. The logistics strategy provides an opportunity to make our Space Science Programs affordable.

### 3.0 OSSA INTEGRATED LOGISTICS SUPPORT PLANNING DOCUMENT

#### 3.1 GENERAL

The OSSA Integrated Logistics Support Planning Document provides guidance for use in preparing and updating an Integrated Logistics Support Plan (ILSP). It provides clear, concise, and detailed instructions on the preparation and content of an ILSP to ensure a quality document that reflects total ILS program requirements. The ILSP is prepared at OSSA payload program level and describes the payload ILS program in detail.

#### 3.2 PROCEDURES

The payload program manager will draft an ILSP during Phase B and keep it current throughout acquisition. The ILSP will integrate logistics elements of the program. The approved ILSP becomes the ILS program implementation plan for all participating activities. It is included as part of the program management documentation. The latest approved ILSP will be used as a working document by all ILS program participants. The ILSP is the principal logistics document for an acquisition program and serves as a source document for summary information required in other program management documents. The ILSP describes the overall ILS program including requirements, tasks, and milestones for the immediate acquisition phase and plans for succeeding phases. The plan is tailored to the specific needs of each program and will address the total system including the payload, training devices, and support

equipment. The ILSP provides: a complete plan for support of the operational payload; details of the ILS program and its relationship with overall program management; information to decision making bodies on ILS aspects necessary for sound decisions on further development of the system; and information necessary for the preparation of the ILS sections of procurement documents. The ILSP is a dynamic document. It is updated: when new program direction is received; when there are changes that involve personnel, training, facilities, or other ILS planning elements; before key decisions in the system acquisition cycle; when there are major system configuration changes; and prior to development of solicitation documents.

### 3.3 CONTENT

The ILSP contains the three sections listed below and any necessary annexes. The content of each element is detailed in Volume III, OSSA Integrated Logistics Support Planning Document.

#### a. Section I, General

1. Introduction
2. System Description
3. Program Management
4. Applicable Documents

#### b. Section II, Plans, Goals, and Strategy

1. Mission Need Statement
2. Acquisition Strategy
3. Logistics Support Analysis (LSA) Strategy
4. Supportability Test and Evaluation
5. ILS Element Plans

#### c. Section III, ILS Milestone Schedule

#### d. Annexes (as applicable).

## 4.0 SUPPORTABILITY ANALYSIS OF THE 1.8 M CENTRIFUGE

### 4.1 GENERAL

The supportability analysis of the 1.8 M centrifuge in the Life Science Research Facility focuses on reliability, maintainability, and commonality considerations in system development and their potential impact on supportability and affordability. The analysis outlines standard logistics engineering methodologies that are employed to incorporate integrated logistics support planning into the early phases of system development in an effort to influence design and reduce future logistics support requirements.

The Centrifuge is but one of four or more specimen holding and management equipment items which will be closely integrated to form the heart of the Life Sciences Research Facility. Centrifuge designs exist only as conceptual designs at present, but specific logistics concerns have already surfaced in the areas of reliability, maintainability and commonality.

### 4.2 RELIABILITY

The supportability analysis of the centrifuge examined the subsystem relationships. One area of concern was the series relationship of nine components of the centrifuge with no built-in redundancy. Even if these components were designed for a life of 25 years with no failures, the resulting system Mean Time Between Failure (MTBF) would be 2.8 years. If the components have a

more realistic lifetime of 4 years, the resulting system MTBF would be less than 180 days. Component redundancy will be crucial to mission success for the 1.8 M centrifuge.

#### 4.3 MAINTAINABILITY

Maintainability is a key design consideration for the 1.8 M centrifuge. All critical components within the centrifuge will be functionally packaged and designed as ORUs. The centrifuge will incorporate BIT/BITE to isolate failures to the ORU level. On-orbit repair of centrifuge ORUs will be analyzed. If centrifuge ORUs are chosen for on-orbit repair, then they will be designed to be tested with test equipment that is available on the Space Station. Test equipment will isolate failures to the subassembly level, and spares will be available on the Space Station. The capability to replace failed ORUs while the centrifuge is operating will also be considered. Location of spare ORUs will be analyzed in conjunction with required/available on-board storage space. Other maintainability considerations are training and technical data requirements. These considerations will be applied to all candidate subsystems and incorporated as design requirements. A specific example is the ball bearing suspension system that has been chosen as the leading option for the suspension system. The ball bearing system requires that its oil system be serviced at a 5-year interval. The logistician will assess the impact on support equipment requirements, skills required to perform the servicing, time required to perform the tasks, and contamination or other hazards involved.

#### 4.4 COMMONALITY

Commonality in design will be emphasized to reduce logistics requirements and cost. The current centrifuge concept requires three drive motors, one for each of the rotors: the main rotor, the service rotor, and the compensator. Each motor is different due to different torque requirements. No motor redundancy is planned. Designers should look at the possibility of common motors. Commonality of design should also be considered for the power transformers and optical couplers. All standardization achieved will improve supportability of the centrifuge.

Intensive supportability analyses paralleling, and coupled with, Phase B 1.8 M centrifuge system definition and preliminary design studies will penetrate these and other potential problems in detail. They will provide the program manager with logistics planning tools to ensure the successful development and operation of the centrifuge. If, as seems likely, NASA develops the core group of specimen habitats, centrifuges, a multipurpose workbench, specimen husbandry devices and equipment cleaning hardware as a single development entity, then simultaneous, integrated, in-depth supportability analyses of these payload elements will constitute an essential early step in the Life Sciences Research Facility program.

## 5.0 SUMMARY

### 5.1 GENERAL

The OSSA Logistics Study has developed an OSSA Integrated Logistics Support Strategy. The strategy involves the establishment of an OSSA Integrated Logistics Support Program. The major objective of the ILS program is supportability of all OSSA payloads at an affordable life-cycle cost. Establishment of an OSSA ILS program and accomplishment of this objective requires a firm commitment from OSSA. This commitment requires establishing an OSSA logistics policy and an OSSA level logistics organization. Implementation of the OSSA logistics strategy is time-sensitive and will require close coordination with the Space Station Program and other NASA programs.

The OSSA Integrated Logistics Support Planning Document establishes standard procedures for preparing Integrated Logistics Support Plans (ILSPs) at OSSA payload program level. Standard ILSPs will ensure common direction and control of payload logistics programs.

The supportability analysis of the 1.8 M centrifuge was a preliminary look at some of the key supportability issues. This document shows the importance of early ILS planning in system development. The decisions made now, for individual pieces of equipment or for all OSSA payloads, will dictate

future support requirements and costs. These requirements and costs can be minimized through an effective Integrated Logistics Support program.

## 5.2 FUTURE NEEDS

The future need for additional logistics studies, analyses, and plans were discussed in detail throughout the study, but can be summarized as follows:

- o Establish an OSSA logistics policy.
- o Develop an OSSA level logistics plan.
- o Conduct logistics studies and analyses to establish common procedures in the following areas: logistics information system; logistics support plans; repair level analysis; repair parts screening; source, maintenance, and recoverability coding; technical data packages; facilities; and packaging, handling, storage, and transportation.
- o Conduct supportability analyses for all OSSA payload hardware.
- o Develop Integrated Logistics Support Plans for all OSSA payloads.
- o Coordinate all actions for integrating the logistics support of all OSSA payloads.
- o Establish a single point of contact for OSSA logistics and the interface with SSP and other NASA organizations.



S2-12  
124529  
368

PRELIMINARY ANALYSIS  
OF AN  
INTEGRATED LOGISTICS SYSTEM  
FOR  
OSSA PAYLOADS

N88-19479

Volume II

OSSA Integrated Logistics Support  
Strategy

T. Palguta, W. Bradley and T. Stockton  
Lockheed  
Huntsville Engineering Center  
Contract Number NAS8-32697

April 1987

George C. Marshall Space Flight Center  
National Aeronautics and Space Administration  
Huntsville, AL 35812

PRECEDING PAGE BLANK NOT FILMED

## 1.0 INTRODUCTION

### 1.1 PURPOSE

The purpose of this document is to outline an Office of Space Science and Applications (OSSA) Integrated Logistics Support (ILS) strategy that will insure effective logistics support of OSSA payloads at an affordable life-cycle cost.

### 1.2 SCOPE

The provisions of this document apply to the Office of Space Science and Applications, all payload programs under their auspices, and contractors having management and/or technical responsibility for OSSA programs.

PRECEDING PAGE BLANK NOT FILMED

## 2.0 LOGISTICS STRATEGY

### 2.1 GENERAL

The strategy for integrating OSSA logistics requirements will be to establish an OSSA Integrated Logistics Support Program. Full understanding, concise planning, and common policy and direction for OSSA programs are required to achieve a cost and operationally effective integrated logistics support program. Key to establishing a meaningful logistics program is the initial activity involving the development and communication of basic logistics policies, plans and procedures. These activities form the foundation and provide the common guidance for all OSSA Payload Program Managers in the planning, analyzing, designing, and supplying of logistics services and support resources. The resulting active participation and full communication assures the development of effective interfaces and working relationships, a common base of understanding across OSSA, identification and development of the most cost effective approach, and responsive implementation of requirements.

Specific policies, plans and procedures that will be developed to establish an OSSA Integrated Logistics Support Program are described in Section 4 of this document. The policies, plans, and procedures will be developed through a series of logistics studies and analyses. The results of the studies and analyses will be documented in an OSSA Logistics Plan.

## 2.2 OBJECTIVES

The objectives of the OSSA logistics strategy are as follows:

- a. Minimize system support and life cycle costs for OSSA payloads.
- b. Establish an OSSA integrated logistics system responsive to the support of payload design, development and operations.
- c. Integrate logistics across the various OSSA payload programs to ensure that each payload's logistics requirements can be effectively merged into a single OSSA logistics system.
- d. Assure visibility at OSSA level over all major logistics activities and resources within the payload programs.
- e. Assure that logistics is considered in early design activities to ensure long-term program supportability.
- f. Assure acquisition of only those materials, equipment and services necessary by optimizing the use of existing facilities, equipment, capabilities, and hardware from other programs.
- g. Ensure the timely availability of required equipment, materials, and services within budget limitations.
- h. Assure communication and coordination among OSSA programs, other NASA program offices, and other applicable agencies.

## 2.3 ORGANIZATION

The establishment and implementation of an OSSA Integrated Logistics Support Program will require the establishment of a functional OSSA ILS organization. Figure 2-1 portrays the organizational relationships for management of OSSA logistics activities. General responsibilities for accomplishment of these activities are outlined below.

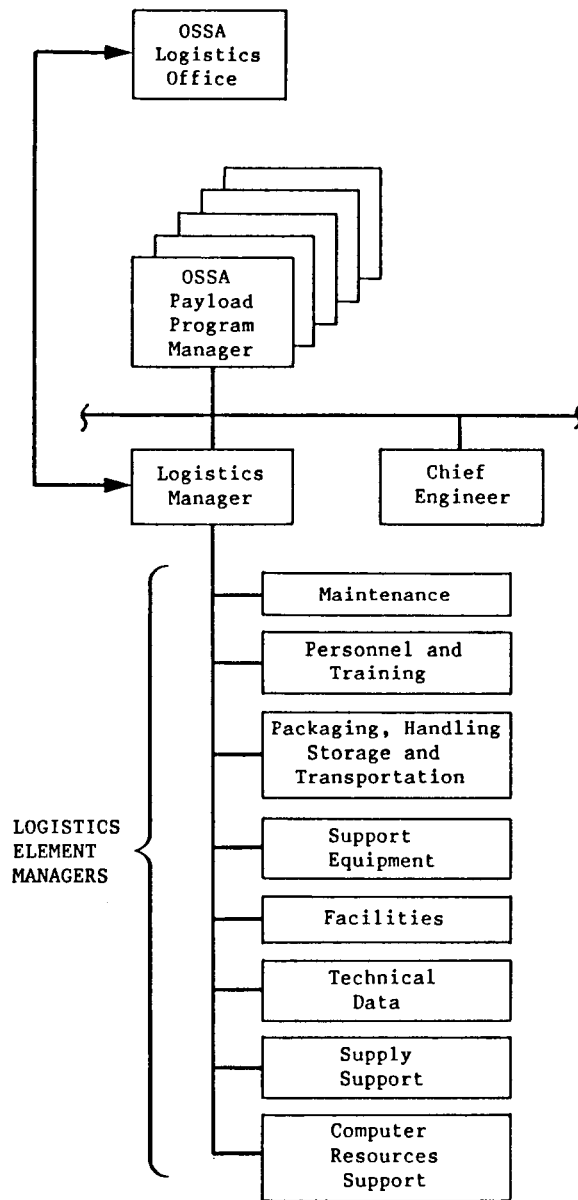

Fig. 2-1 Logistics Organization

### 2.3.1 OSSA

OSSA is responsible for development of an integrated logistics system and for managing the integration of OSSA payload program logistics activities. OSSA will coordinate the identification of management level logistics interface points for each organization, including the payload programs, other NASA programs and other applicable logistics organizations. Interfaces established will be the points of contact for overall integration of logistics. This responsibility includes the following:

- a. The development and implementation of an OSSA Integrated Logistics Support Program which includes development and implementation of logistics policies, plans, procedures, guidelines, and requirements.
- b. The establishment of a logistics office to integrate and coordinate all logistics matters. This includes interfaces with payload programs and other NASA Program Offices.
- c. The review of payload program logistics plans for compliance with program requirements.
- d. Establish an Integrated Logistics Working Group (ILWG) to develop and coordinate requirements and resolve problems concerning the ability of payload programs to implement OSSA logistics policies and procedures.
- e. Maintain visibility over major logistics activities and resources within the payload programs.
- f. Measure the effectiveness of the implementation of the ILS strategy and program throughout OSSA.
- g. Review and approve logistics budgetary requirements.

### 2.3.2 Payload Programs

Payload Program Managers will:

- a. Ensure that O SSA logistics policies, plans, procedures, guidelines and requirements are implemented.
- b. Establish a logistics function to integrate and coordinate all logistics matters to include interfaces with O SSA and other payload programs.
- c. Provide logistics plans to O SSA for review.
- d. Assure that logistics has the responsibility of concurrence on all design review and approval processes.
- e. Participate in the O SSA Integrated Logistics Working Group (ILWG).
- f. Assess the effectiveness of the Integrated Logistics Support Program.

## 3.0 IMPLEMENTATION

### 3.1 GENERAL

Implementation of the OSSA logistics strategy will result in the establishment of an integrated logistics support program for OSSA.

Implementation of the OSSA logistics strategy will require conducting logistics analyses, identifying standard logistics procedures, sharing and developing logistics support resources, and establishing programs to reduce the demand for logistics support resources. Because each OSSA program is unique, with different requirements, and in different stages of development, the logistics programs cannot be implemented in the same manner for all programs. The special program characteristics and stage of development will be considered when establishing a logistics program. The strategy will be implemented in phases, with the final objective being a standardized, integrated logistics program within OSSA and across all NASA programs. This integrated logistics program will be able to provide optimum logistics support at minimum cost.

Implementation of the OSSA logistics strategy will occur in phases. In addition, implementation is time sensitive.

Implementation will begin as soon as possible to maximize logistics interfaces and resource sharing between OSSA and the Space Station Program.



The implementation of the OSSA logistics strategy will be supported by the issuance of an OSSA logistics policy letter and the formation of an OSSA level logistics office. Figure 3-1 shows the phased implementation of the OSSA logistics strategy.

### 3.2 PHASE I

The first phase of implementation of the OSSA logistics strategy is a data collection and analysis phase. It will be necessary to collect and analyze data on all the logistics procedures, programs, systems, and resources that are currently in use within OSSA, other NASA programs, and other applicable agencies. Establishing logistics interfaces across OSSA/NASA will be essential to the successful completion of this phase. The analysis will determine the best, most efficient, cost effective logistics program for OSSA. The analysis will also include evaluation of new logistics support concepts. Included in this analysis will be an evaluation of the logistics procedures, programs, systems, and resources that the Space Station Program plans to use. Due to the many OSSA/SSP logistics interfaces, it is essential that the logistics programs are complementary. This analysis will lead to the choice of standard logistics procedures, programs, systems, and resources to be implemented across OSSA programs. Specific procedures, programs, systems, and resources to be analyzed are identified and described in Section 4 of this document.

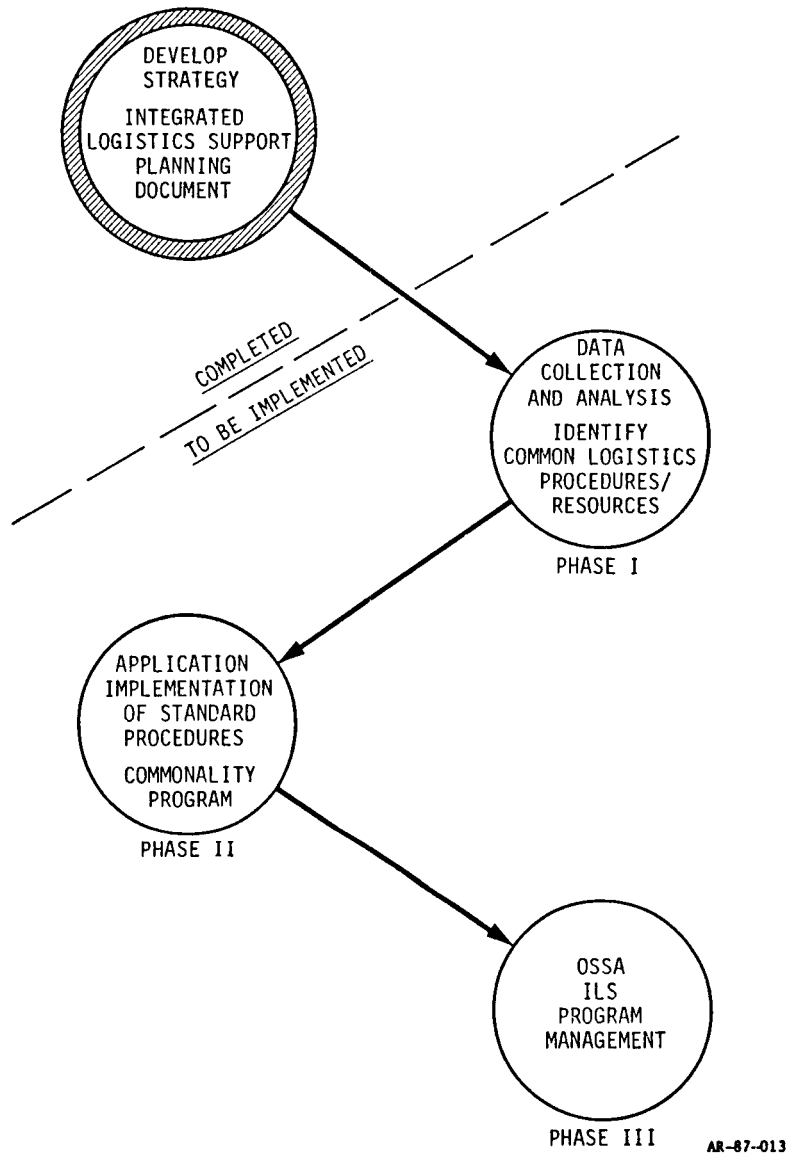

Fig. 3-1 ILS Strategy Implementation Phases

### 3.3 PHASE II

The second phase of implementing the OSSA logistics strategy will be application of the standard procedures, programs, systems and resources across all OSSA programs. Application to new programs will involve tailoring the standards to the unique characteristics of the payload. Application of the standards to payloads with existing procedures, programs, systems and resources will involve an analysis to determine which standards can be cost effectively integrated into the program to improve logistics support capabilities at a reduced life-cycle cost. In both cases, it will be necessary to analyze the impact of the application of the standards to the payload program.

### 3.4 PHASE III

The final phase of implementation will involve maintaining the standard, integrated OSSA logistics program. This phase will be continuous and will consist of the following activities:

- o Provide logistics advice/guidance to payload programs.
- o Review and evaluate payload program logistics plans and programs.
- o Conduct logistics cost analysis and budgeting.
- o Review and upgrade logistics procedures, programs, plans, systems and resources.
- o Review payload program logistics reports/data through the LIS.
- o Conduct/attend logistics reviews and working group meetings.
- o Represent the consolidated OSSA logistics interests/requirements.

- o Integrate the various payload commonality programs and manage the O SSA commonality program.
- o Oversee the development and operation of the consolidated logistics facility.

## 4.0 COMMONALITY

### 4.1 GENERAL

Commonality is defined as the use of identical or similar hardware, software, standards, and technical approaches to satisfy multiple sets of functionally similar requirements.

The key to development and implementation of an efficient, cost-effective OSSA Integrated Logistics Support Program is the definition and establishment of common logistics policies, plans, procedures, and support resources within OSSA and other NASA organizations. Commonality within the OSSA logistics program will start with the development of standard procedures for the Logistics Support Analysis (LSA) of all OSSA payloads. LSA is a set of systematic and comprehensive analyses performed during the conceptual, design, and development phases of a program to identify support criteria and operational support system resources. The LSA process is the technical driving force for an ILS program. The LSA process is a major contributor to the optimization of system logistics and maintenance support requirements and resources and provides justification and source data for the acquisition of support equipment, spares, repair parts, consumables, technical data, support facilities, tools, personnel, and training. LSA is performed in conjunction with design, and interacts with and supports other functional areas to ensure commonality of analysis and nonduplication of effort.

The remainder of this section addresses subordinate logistics areas that will be analyzed and developed for commonality application. Results of logistics studies and analyses will be documented in an O SSA Logistics Plan. Figure 4-1 shows the logistics commonality program interface between O SSA and the payload programs.

#### 4.2 LOGISTICS SUPPORT PLANS

O SSA will require, and provide guidance for, the preparation of O SSA payload program logistics support plans. In addition, a review loop at O SSA will be established for these plans. O SSA will formulate a policy statement to implement the requirement for these plans. The guidance for developing an Integrated Logistics Support Plan (ILSP) is contained in the Integrated Logistics Support Planning Document that is Volume III of this study.

The ILSP is the key logistics document that provides the common direction and control required to meet the logistical needs of payload programs. The ILSP addresses all logistics elements, to include: maintenance; technical data and documentation; supply support; logistics facilities; packaging, handling, storage, and transportation; logistics support personnel and training; support equipment; and the logistics information system. These logistics elements will be developed in greater detail through preparation of separate logistics plans for each element. Logistics procedures that are developed through special studies and analyses will be documented in the appropriate logistics support plan.

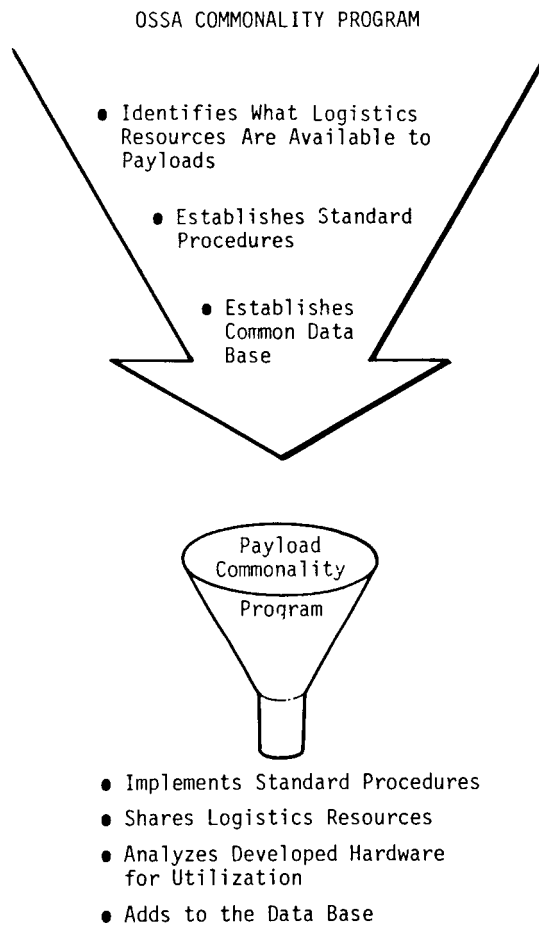

Fig. 4-1 Commonality Program Interface

#### 4.2.1 Maintenance Plan

This plan provides the integrated planning and analysis process which addresses the requirement to assess the design as it relates to maintenance and the development of maintenance requirements.

#### 4.2.2 Technical Data and Documentation Plan

This plan provides the technical data and the documentation planning which prescribes general procedures, terms, and conditions for planning, preparation, and delivery of technical data required for training, maintenance, and operational support of equipment.

#### 4.2.3 Supply Support Plan

This plan describes the processes for meeting the spare and repair parts requirements. The plan will specifically address provisioning procedures and requirements. Also, the plan will address the use of the LSA process and the maintenance plan in the development and definition of spare and repair parts requirements.

#### 4.2.4 Logistics Facilities Plan

This plan provides the facilities planning which includes the facilities and equipment required to support maintenance, training, storage, and installation and checkout.

#### 4.2.5 Packaging, Handling, Storage, and Transportation Plan.

This plan addresses the procedures and resource requirements necessary to insure that all system equipment and support items are transported, preserved, packaged, stored and handled properly.



#### 4.2.6 Logistics Support Personnel and Training Plan

This plan contains qualitative and quantitative information for use by responsible management agencies to identify maintenance personnel requirements by numbers, skills, other qualifications, and training requirements.

#### 4.2.7 Support Equipment Plan

This plan identifies and provides common support equipment and software requirements necessary to accommodate organizational, intermediate, and depot-level maintenance.

#### 4.2.8 Logistics Information System Plan

This plan addresses those data elements, files, reports, and associated hardware and software that provide for status, historical data, trends, management visibility, accountability, performance evaluation, control and allocation of logistics resources.

### 4.3 LOGISTICS INFORMATION SYSTEM (LIS)

The LIS is designed to serve as a comprehensive system which will provide real time status of significant logistics activities to determine and evaluate the supportability of OSSA payload programs. The LIS is key to the coordination of logistics activities within OSSA. The elements of the LIS are described below and shown in Figure 4-2.

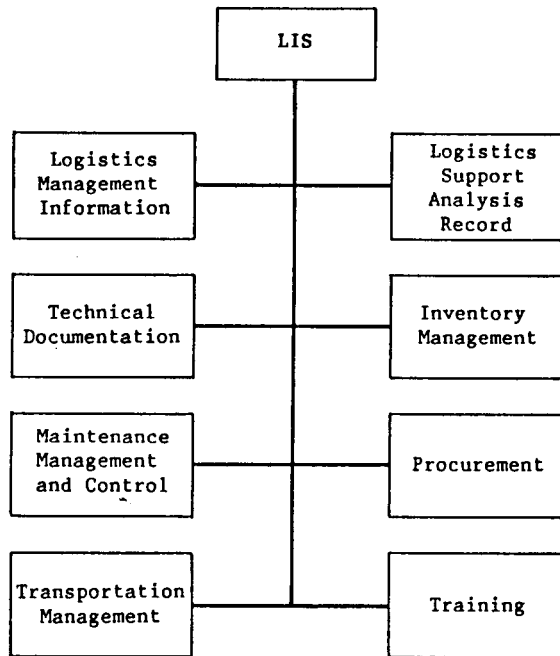

Fig. 4-2 Logistics Information System (LIS) Components

#### 4.3.1 Logistics Management Information System (LMIS)

The LMIS provides visibility and evaluates the performance of OSSA payload program logistics processes. The specific types of information which are included in the LMIS are cost tracking, applicable logistics support scheduling, and technical performance of logistics elements. The LMIS provides the capability to summarize logistics parameters and elements for management visibility and tracking.

#### 4.3.2 Logistics Support Analysis Record (LSAR)

The data developed during the Logistics Support Analysis (LSA) process will be documented and input to an automated data base called the LSAR data base. The LSA process is the analysis from which source data is derived for maintenance technical documentation, maintenance training, personnel requirements, provisioning documentation, support equipment requirements, etc. This analytical process is described in MIL-STD-1388-1A, Logistic Support Analysis. The format for entering the data into the logistics support data base is defined in MIL-STD-1388-2A, DOD Requirements for a Logistic Support Analysis Record. Figure 4-3 shows the inputs to and the outputs from the LSAR data base.

#### 4.3.3 Technical Documentation

The technical documentation component of LIS will provide the capability to maintain current technical data. This technical data, for maintenance and repair, will be used to support on-orbit and ground operations, maintenance, training, and logistics support operations.

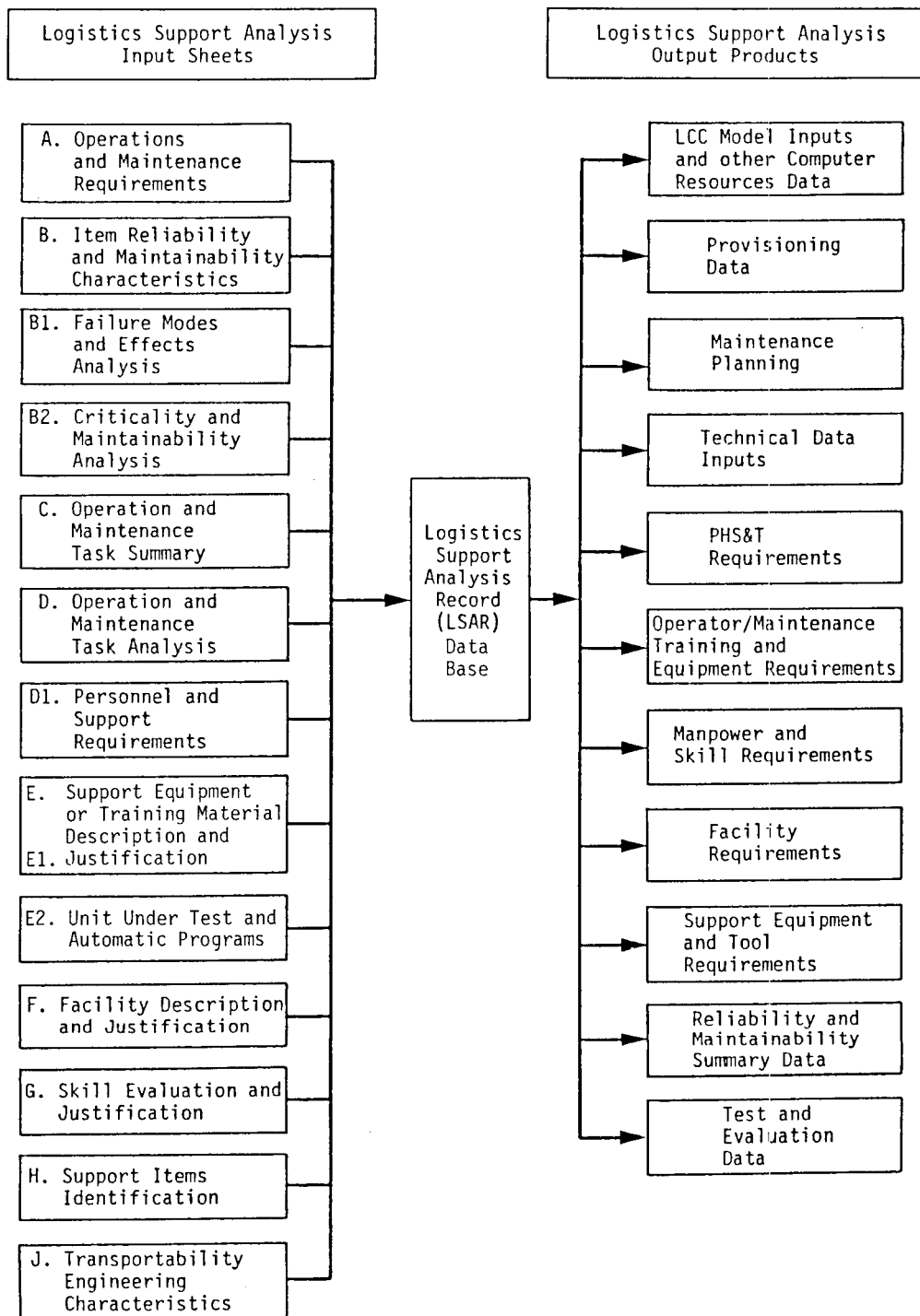

Fig. 4-3 LSAR Inputs/Outputs

#### 4.3.4 Inventory Management System

OSSA will establish a single standard automated inventory management system for all OSSA payloads. The inventory management system is the means by which all OSSA assets (ground and on-orbit) will be identified, integrated and controlled. The inventory management system will organize, manage, and control the spares, equipment, consumables and other materials needed to ensure the support of all OSSA payloads. The inventory management system is responsible for predicting OSSA payload support requirements and assuring the availability and serviceability of those items when needed. Remote terminals will be located at appropriate supply, maintenance, and management locations. The standard inventory management system will provide asset visibility across OSSA and other NASA programs to facilitate utilization of existing assets.

#### 4.3.5 Maintenance Management and Control

The Maintenance Management and Control component of the LIS will provide status information on all maintenance actions both on ground and on-orbit. ORUs will be tracked from on-orbit through all maintenance shops and off-site depots.

#### 4.3.6 Procurement

The procurement component of LIS will be used to track the purchase of logistics support resources. Included as part of this component are:

purchase order contract generation, purchase requisition/purchase order identification tracking and status.

#### 4.3.7 Transportation Management

The automated transportation system will contain documentation of packaging information, shipping constraints (size and weight), traffic management transferability information, handling criteria, environmental requirements, classification, and transportation route restrictions.

#### 4.3.8 Training

The training component tracks maintenance and repair course offerings along with the personnel who are required to take the courses. The automated training system may also schedule personnel for certification and recertification. Certification and recertification of personnel will be tracked and status of the skills available will be provided.

#### 4.4 REPAIR LEVEL ANALYSIS (RLA)

A Repair Level Analysis (RLA) procedure will be established to recommend repair levels for orbital replaceable units (ORUs), assemblies, and subassemblies. The repair level decision will be based upon total support costs within operational and technical constraints over the system design life. The RLA will form the basis for an item's recommended optimum repair level; repair versus discard-at-failure decision; repair parts provisioning; Source, Maintenance, and Recoverability (SMR) coding; and maintenance

planning. The results of the RLA are to be available prior to SMR coding of spares and repair parts. This is a minimum requirement to ensure that the SMR coding and provisioning actions are based upon the best information available. Certain long-lead items will be an exception and will be provisioned prior to completion of the RLA. Figure 4-4 shows the inputs and outputs of the RLA process. The analysis will be performed to the depth required to ensure that the ground and flight systems operational and maintenance requirements are satisfied and that the acquisition of resources is justified. RLA will determine the repair locations for each ORU, assembly, and subassembly. Existing RLA software will be modified and user manuals prepared to standardize and facilitate this analysis for all OSSA payloads.

#### 4.5 REPAIR PARTS SCREENING

Repair parts will be screened by the Defense Logistics Services Center (DLSC) to prevent the entry of items into the NASA inventory that may be available in other Government inventories. Specific procedures will be developed and documented.

#### 4.6 SOURCE, MAINTENANCE AND RECOVERABILITY (SMR) Coding

OSSA will standardize SMR coding procedures for all OSSA payloads. The coding is necessary to devise a maintenance and replenishment strategy for equipment components. Figure 4-5 shows the SMR codes.

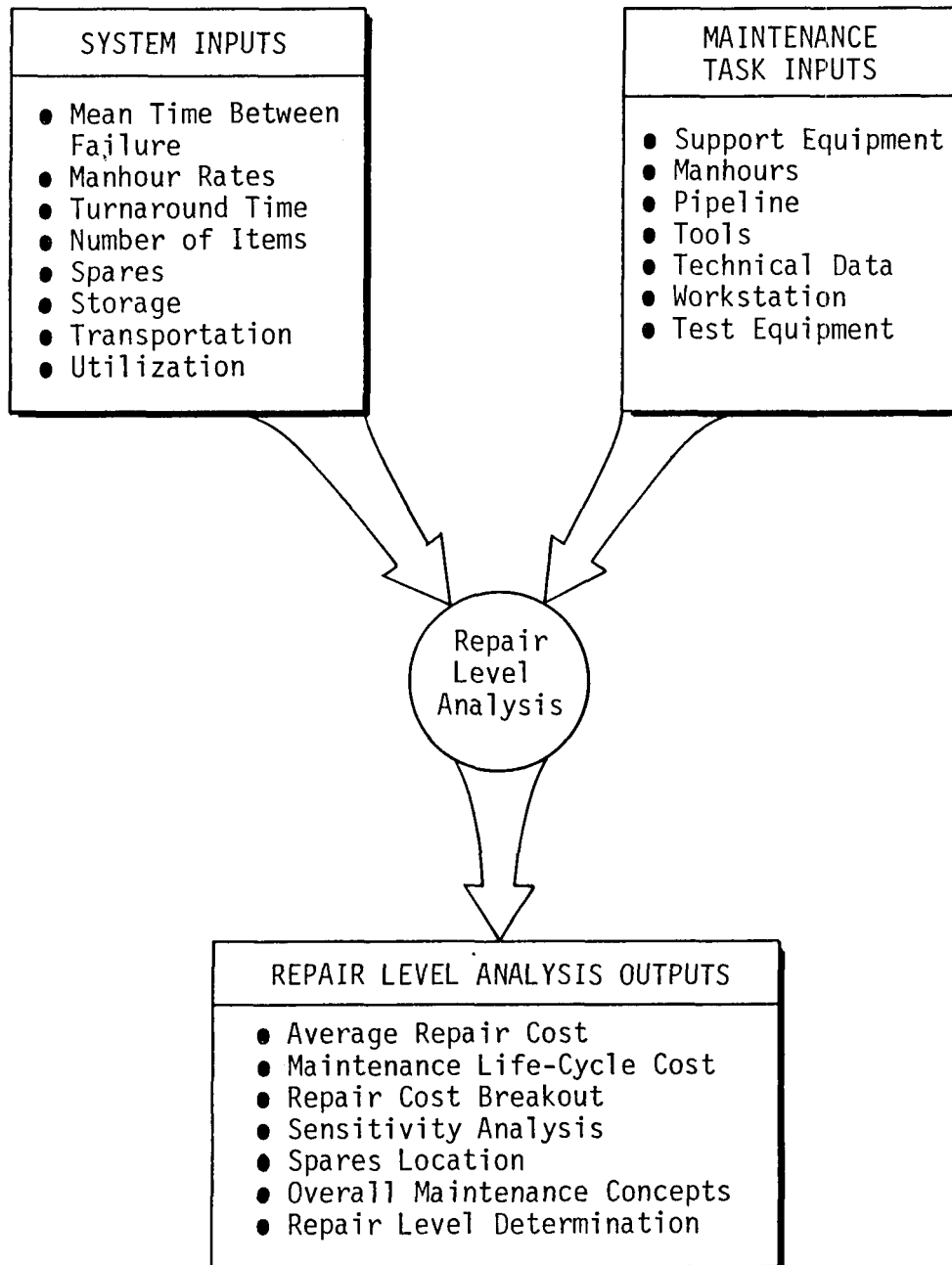

Fig. 4-4 Repair Level Analysis Process



Source			Maintenance		Recoverability			
			Use	Repair				
1st Position	2nd Position		3rd Position	4th Position	5th Position			
P Procurable	A	Stocked	O	Replace at Organizational Levels	Z	No Repair	Z	Nonrepairable Condemn at Any Authorized Level
	B	Insurance			B	No Repair Condition		
	E	GSE			C	No Repair Clean Only	O	Repairable Condemn at Organizational Level
K Component of a Repair Kit	F	Intermediate Kit	F	Replace at Intermediate Levels	O	Repair at Organizational Level	F	Repairable Condemn at Intermediate Level
	D	Depot Kit			F	Repair at Intermediate Levels	D	Repairable Condemn at Depot Level
	B	In Both Kits						
M Manufacture	O	Organizational	D	Replace at Depot Levels Only	D	Repair Limited: Intermediate Overhaul: Depot	L	Repairable Condemn at Technology Repair Center
	F	Intermediate			L	Repair Depot Level Only	A	Special Handling
	D	Depot						
A Assembly	O	Organizational	D	Replace at Depot Levels Only				
	F	Intermediate						
	D	Depot						
X Nonstocked	A	See NHA	D	Replace at Depot Levels Only				
	B	Reclamation from IM						
	C	Drawings Obsolete, etc.						

AR-87-018

Fig. 4-5 Source, Maintenance, and Recoverability (SMR) Codes

#### 4.7 TECHNICAL DATA PACKAGES

Standards will be established for the acquisition of technical data packages. Complete data packages are required from the manufacturers if a NASA depot or another vendor is to be considered as a repair alternative. Acquisition of complete technical data packages will eliminate total reliance on a single vendor for repair. It will also eliminate the associated uncontrolled cost, time to repair, and the risk of loss of repair capability. Technical data packages consist of a wide range of text, drawings, graphics and other forms of information to include: operations and maintenance documentation; diagrams/schematics; illustrated parts breakdown; drawings; computer program documentation; and specifications.

#### 4.8 FACILITIES

OSSA will consolidate logistics support facility requirements for all OSSA payloads and ensure that these facilities are provided in the most cost effective manner. The logistics support facilities are defined as the buildings necessary to house the maintenance support equipment, Orbital Replaceable Units (ORUs), spares, consumables, ORU repair shops, experiment and calibration laboratories, waste management facilities, data management systems, classrooms and training devices for operations/maintenance training, simulators and services to support these facilities. Facility functions are shown in Fig. 4-6.

Each OSSA payload program will be responsible for identifying its logistics support facility requirements to OSSA in a standard format.

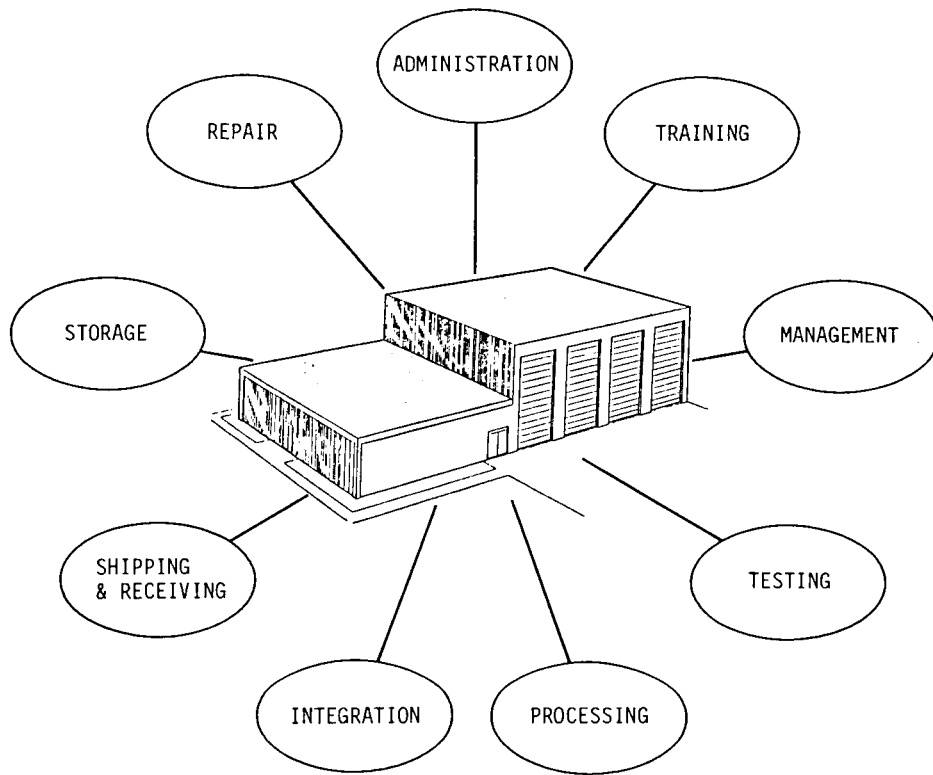

Fig. 4-6 Facility Functions

Support requirements that do not lend themselves to incorporation into a common NASA depot, either for cost or technical reasons, will be identified. Factors to consider include but are not limited to: completeness of technical data packages delivered to the government; cost of warranties versus government depot costs; and vendor versus government ownership of ORU peculiar test equipment.

OSSA will establish a standard format for identifying the logistics facility requirements of the payload programs, consolidate these requirements into the total OSSA logistics support facility requirements, and then provide these facilities in a cost effective/timely manner. This may involve utilization of existing NASA/DoD facilities, incorporation into planned NSTS/SSP facilities, development of OSSA peculiar facilities, or a combination of the above.

#### 4.9 PACKAGING, HANDLING, STORAGE AND TRANSPORTATION (PHS&T)

Procedures will be established to standardize PHS&T practices across OSSA programs. This standardization is essential if a central storage/repair facility is to be developed. It will also baseline the most efficient/cost effective procedures that are utilized in existing NASA programs. Figure 4-7 shows the PHS&T analytical process.

#### 4.10 OPERATIONAL COST MODEL

OSSA will designate a single standard operational cost model for all OSSA payloads. The operational cost model is used as a management tool to

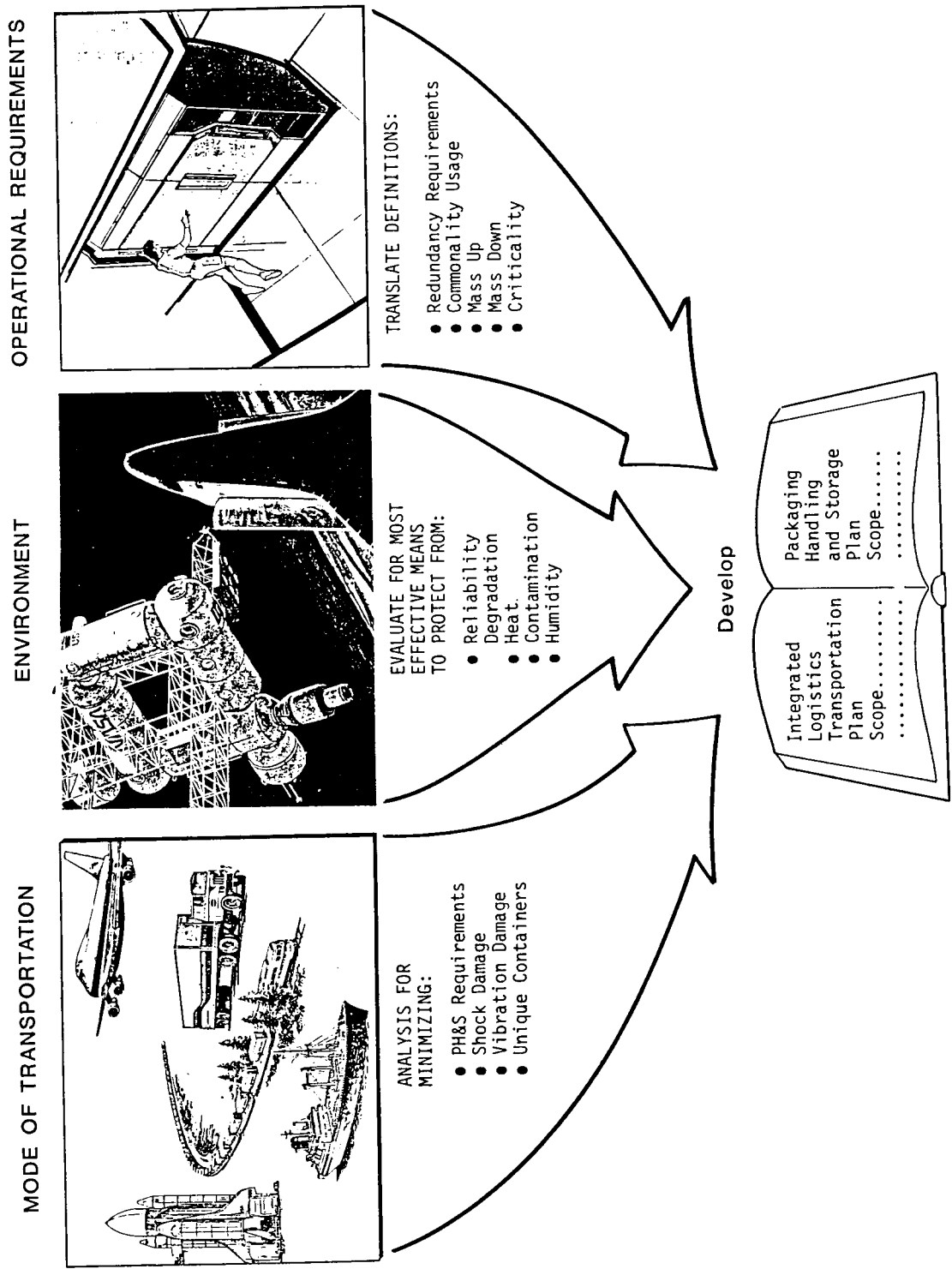
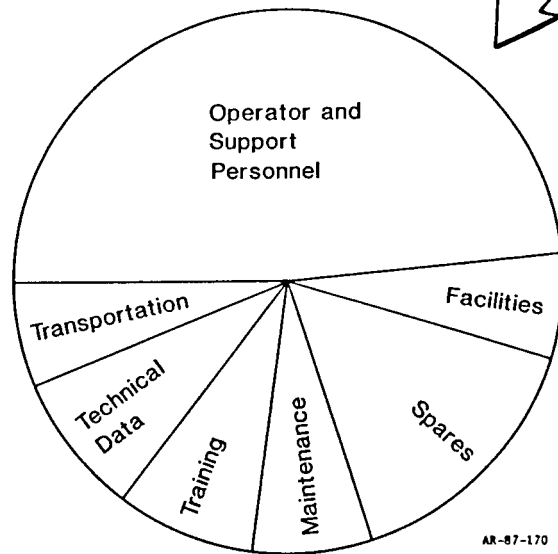
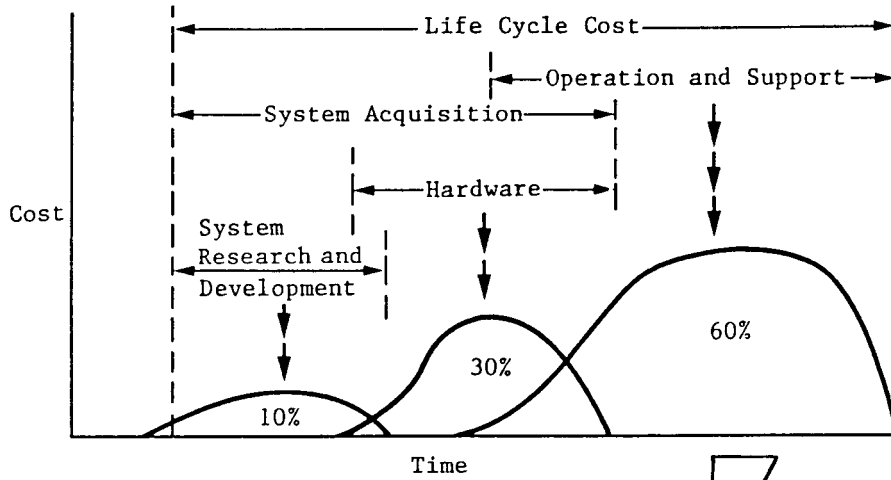

Fig. 4-7 PHS&T Analytical Process

ORIGINAL PAGE IS  
OF POOR QUALITY

facilitate operational cost analysis. The operational cost analysis will commence early in the system development process to estimate operations and support costs. The cost model will identify operations and support cost drivers and perform sensitivity analysis to develop the optimum balance between cost and effectiveness. The initial operations and support cost drivers and estimates will be inputs to the systems engineering process to ensure that design is optimized to minimize operations and support and life cycle costs. Operational cost estimates are revised and improved as programs progress and input data becomes more accurate. Standardization of an operational cost model will provide useful, timely cost information to O SSA managers; permit meaningful comparisons between O SSA payload programs; and facilitate budget preparation. Figure 4-8 shows a typical life cycle and operations and support cost breakout.



Operations and Support  
Cost Breakout

Fig. 4-8 Operations and Support Cost

## 5.0 SUMMARY

This document has formulated an OSSA logistics strategy that will ensure OSSA payload supportability at an affordable life-cycle cost. In Section 2 the logistics strategy, objectives, and logistics organization and functions were described. Section 3 discussed the implementation of the strategy. The implementation of the OSSA logistics strategy is supported by the issuance of an OSSA logistics policy letter and the formulation of an OSSA level logistics organization. The organization will interface with the payload program logistics organizations and other NASA program logistics organizations. The implementation of the strategy is phased, with Phase I the data collection and analysis phase, Phase II the application phase, and Phase III the maintenance phase. This phasing provides a methodology for developing the strategy. It is a systematic approach to the development and operation of the OSSA Integrated Logistics Support Program. Section 4 details the specific logistics plans, procedures, and resources that will be analyzed and developed for commonality application. The results of the logistics studies and analyses will be incorporated into a series of OSSA-level logistics plans. Conducting the appropriate logistics studies and analyses and developing the OSSA-level logistics plans is the next step in developing and establishing an OSSA Integrated Logistics Support Program. The ILS Program will enable OSSA to come to grips with logistics support costs and ensure supportability of all OSSA payloads. The logistics strategy provides an opportunity to make our Space Science Programs affordable.



## GLOSSARY

Commonality - The use of identical or similar hardware, software, standards, and technical approaches to satisfy multiple sets of functionally similar requirements.

Depot - Facility for performing maintenance on material requiring major overhaul or a complete rebuild of parts, assemblies, subassemblies, and end-items, including the manufacture of parts, modifications, testing, and reclamation as required.

Integrated Logistics Support (ILS) - A disciplined approach to the activities necessary to: (a) cause support considerations to be integrated into system and equipment design; (b) develop support requirements that are consistently related to design and to each other; (c) acquire the required support; and (d) provide the required support during the operational phase at minimum cost.

Integrated Logistic Support Management Team (ILSMT) - A management group responsible for monitoring the ILS process for a given system or payload to ensure adherence to the requirements in the ILS Plan.

Integrated Logistic Support Plan (ILSP) - The plan developed to incorporate all elements of ILS for the life of a system.

Inventory Management System (IMS) - The means by which assets are identified and controlled. The system organizes, manages, and controls the spares, equipment/consumables and other materials needed to ensure the support of systems/subsystems in accomplishing their mission.

Life Cycle Cost (LCC) - The total cost of a system from its inception to its retirement.

Logistics Management Information System (LMIS) - A system that provides the essential management visibility to ensure timely and cost-effective accomplishment of logistics requirements. The main elements are logistics schedules and status reports which will provide a basis for evaluating logistics performance.

Logistic Support Analysis (LSA) - The selective application of scientific and engineering efforts undertaken during the acquisition process, as part of the system engineering and design process, to assist in complying with supportability and other ILS objectives.

Logistic Support Analysis Record (LSAR) - That portion of LSA documentation consisting of detailed data pertaining to the identification of logistic support resource requirements of a system/equipment.

Long-lead Item - An item, which, because of its complexity of design, complicated manufacturing process, or limited production capacity, causes production or procurement cycles which would preclude timely or adequate delivery, if not ordered in advance of normal provisioning.

Maintainability - The measure of the ability of an item to be retained in or restored to specified condition when maintenance is performed by personnel having specified skill levels, using prescribed procedures and resources, at each prescribed level of maintenance and repair.

Maintenance - All action taken to retain materiel in or to restore it to a specified condition. It includes: inspection, testing, servicing, classification as to serviceability, repair, rebuilding, and reclamation.

Mission Need Statement - A clear, concise description of a specified task, its requirements, and its purpose.

Operations and Support (O&S) Costs - The cost of operation, maintenance, and follow-on logistics support of the end items and their associated support systems.

Orbital Replaceable Unit (ORU) - Any assembly that can be removed and replaced as a unit from an on-orbit system.

Packaging, Handling, Storage, and Transportation (PHS&T) - The resources, processes, procedures, design considerations and methods to ensure that all system equipment and support items are preserved, packaged, handled, and transported properly. This includes environmental considerations and equipment preservation requirements for short and long term storage, and transportability. This is one of the principal elements of ILS.

Parts Screening - Process of assigning National Item Identification Numbers (NIINs) to items to prevent duplicate items from entering the defense supply system.

Phase A - Preliminary analysis to identify and explore alternate concepts to satisfy a validated need.

Phase B - The definition phase when selected candidate solutions are refined through extensive study and analysis.

Phase C - The design phase which includes the detailed definition of the final objectives and project concept.

Phase D - The development/operations phase which covers final hardware design and development, fabrication, test, and project operations.

Provisioning - The process of determining and acquiring the range and quantity (depth) of spares and repair parts, and support and test equipment required to operate and maintain an end item of materiel for an initial period of service.

Reliability - The duration of probability of failure-free performance under stated conditions.

Repair Level Analysis (RLA) - A process for recommending repair levels of units, assemblies, and subassemblies which will accrue minimum total support costs within operational and technical constraints over the system design life. It forms the basis for assigning repair level; repair versus discard-at-failure decision; repair parts provisioning; and Source, Maintenance, and Recoverability (SMR) coding, maintenance planning, and documentation.

Repair Parts - Those support items that are an integral part of the end item or system which are coded as nonreparable.

Source, Maintenance, and Recoverability (SMR) Codes - Uniform codes assigned to all support items to convey maintenance and supply instructions to the various logistics support levels. They are assigned based on the logistic support planned for the end item and its components. The uniform code format is composed of three, two character parts; Source Codes, Maintenance Codes, and Recoverability Codes in that order.

Spares - Those support items that are an integral part of the end item or system which are coded as repairable.

Support Requirements Analysis (SRA) - An analysis accomplished during the system design to establish logistics support requirements. The analysis is a step-by-step process of predicting operational and maintenance activities, and defining and documenting the required resources.

Supply Support - All management actions, procedures, and techniques used to determine requirements to acquire, catalog, receive, store, transfer, issue, and dispose of secondary items. This includes provisioning for initial support as well as replenishment supply support. This is one of the principal elements of ILS.

Supportability - The degree to which system design characteristics and planned logistics resources, including manpower, meet system readiness and utilization requirements.

Support Equipment - All equipment required to support the operation and maintenance of a system. This includes associated multiuse end items, ground-handling and maintenance equipment, tools, test equipment, and automated test equipment. It includes the acquisition of logistics support for the support and test equipment itself. This is one of the principal elements of ILS.

Sustaining Engineering - The on-going engineering process of maintaining and operating a system once it is deployed. This process continues throughout the life of the system.

Test, Measurement, and Diagnostic Equipment (TMDE) - Equipment used to determine the operability of system hardware and support equipment.

Technical Data Package - Recorded information regardless of form or character (e.g., manuals, drawings) of a scientific or technical nature for a given system. Computer programs and related software are not technical data; documentation of computer programs and related software are. Also excluded are financial data or other information related to contract administration. This is one of the principal elements of ILS.

Transportability - The inherent capability of materiel to be moved with available and projected transportation assets to meet established schedules.

S3 -12  
124530  
208.

PRELIMINARY ANALYSIS  
OF AN  
INTEGRATED LOGISTICS SYSTEM **N88-19480**  
FOR  
OSSA PAYLOADS

Volume III  
OSSA Integrated Logistics Support  
Planning Document

T. Palguta, W. Bradley, and T. Stockton  
Lockheed  
Huntsville Engineering Center

Contract Number NAS8-32697

April 1987

George C. Marshall Space Flight Center  
National Aeronautics and Space Administration  
Huntsville, AL 35812

PRECEDING PAGE BLANK NOT FILMED

## 1.0 INTRODUCTION

### 1.1 PURPOSE

This document provides guidance for use in preparing and updating an Integrated Logistics Support Plan (ILSP). It provides clear, concise, and detailed instructions on the preparation and content of an ILSP to ensure a quality document that reflects total ILS program requirements.

### 1.2 SCOPE

The provisions of this document apply to the Office of Space Science and Applications, all payload programs under their auspices, and contractors having management and/or technical responsibility for OSSA programs.

PRECEDING PAGE BLANK NOT FILMED

## 2.0 ILS OVERVIEW

### 2.1 DEFINITION

An ILS program improves operational availability and logistic support management while minimizing operations and support costs. The ILS process has two main goals: insuring that logistics considerations are integrated into the design effort, and insuring the design, development, test and acquisition of the support that will ensure availability and affordability of the developed system.

ILS is a disciplined, unified, and iterative approach to the management and technical activities necessary to:

- a. Integrate support considerations into system and equipment design.
- b. Develop the support requirements.
- c. Acquire the required support.
- d. Provide the required support during the operational phase at minimum cost.

### 2.2 ILS POLICY

- a. Acquisition programs will include an ILS program that begins at payload program initiation and continues for the life of the system.
- b. Supportability is a principal design and program requirement as important as cost, schedule, and performance. It will be an equally weighted consideration in developing the acquisition strategy. Supportability will be considered in all program and budget decisions, trade-off analyses, test and evaluation, and other program events in the acquisition process.

c. All elements of the support system must be planned, acquired, tested, and deployed in phase with the payload. A support system must consist of those tangible logistics support resources required to sustain an operational payload. The support system is developed and tested with the payload and is ultimately merged with the ongoing logistics system upon production and deployment. The ILS elements are:

1. Maintenance Planning
2. Manpower and Personnel
3. Supply Support
4. Support Equipment
5. Technical Data
6. Training and Training Support
7. Computer Resources Support
8. Facilities
9. Packaging, Handling, Storage, and Transportation
10. Design Interface

All elements of ILS must be developed in coordination with each other. Trade-offs may be required between elements in order to acquire a system that is within cost constraints.

### 2.3 ILS OBJECTIVES

The objectives of ILS are to:

- a. Influence system requirements and design to achieve and sustain established operational requirements while minimizing operations and support costs.
- b. Ensure that all ILS elements are planned, developed, tested, evaluated, acquired, and deployed prior to or concurrently with the system.
- c. Improve logistics commonality within OSSA, NASA, and other agencies.
- d. Optimize system support throughout the life of the system.



## 3.0 ILSP PROCEDURES

### 3.1 DEVELOPMENT

The payload program manager will draft an ILSP during Phase B and keep it current throughout acquisition. The ILSP will integrate the logistics elements of the program.

### 3.2 IMPLEMENTATION

The approved ILSP becomes the ILS program implementation plan for all participating activities. It is included as part of the program management documentation. The latest approved ILSP will be used as a working document by all ILS program participants.

### 3.3 DESCRIPTION

The ILSP is the principal logistics document for an acquisition program and serves as a source document for summary and consolidated information required in other program management documents. The ILSP describes the overall ILS program including requirements, tasks, and milestones for the immediate acquisition phase and plans for succeeding phases. The plan is tailored to the specific needs of each program and will address the total system including the payload, training devices, and support equipment. The ILSP provides:

- a. A complete plan for support of the operational payload.
- b. Details of the ILS program and its relationship with overall program management.
- c. Information to decision making bodies on ILS aspects necessary for sound decisions on further development of the system.
- d. Information necessary for the preparation of the ILS sections of procurement documents.

#### 3.4 TIME PHASING

The ILSP is a dynamic document. The initial ILSP is prepared prior to the first key decision in the system acquisition cycle. The ILSP is updated:

- a. When new program direction is received.
- b. When there are changes that involve personnel, training, facilities, or other ILS planning elements.
- c. Before key decisions in the system acquisition cycle.
- d. When there are major system configuration changes.
- e. Prior to development of solicitation documents.

## 4.0 ILSP CONTENT

### 4.1 ORGANIZATION

The ILSP contains the three sections listed below and any necessary annexes.

#### 4.1.1 Section I, General

1. Introduction
2. System Description
3. Program Management
4. Applicable Documents

#### 4.1.2 Section II, Plans, Goals, and Strategy

1. Mission Need Statement
2. Acquisition Strategy
3. Logistics Support Analysis (LSA) Strategy
4. Supportability Test and Evaluation
5. ILS Element Plans
  - a. Maintenance Plan
  - b. Logistics Support Personnel and Training Plan

- c. Supply Support Plan
- d. Support Equipment Plan
- e. Technical Data and Documentation Plan Plan
- f. Logistics Facilities Plan
- g. Logistics Information System Plan
- h. Packaging, Handling, Storage, and Transportation Plan

#### 4.1.3 Section III, ILS Milestone Schedule

#### 4.1.4 Annexes (as applicable)

### 4.2 CONTENT OF SECTION I - GENERAL

#### 4.2.1 Introduction - Provide general background information about the system being acquired, if available. The following areas will be addressed:

- a. Purpose - Provide a brief statement on the uses that will be made of the ILSP.
- b. Background - Summarize past actions and events. Identify major decision points and any significant program changes that have taken place.
- c. Application - State what the ILSP covers and what life cycle phase(s) it applies to.
- d. Iteration - Identify the latest ILSP iteration by number and date. Summarize the latest changes made, and state when the next review is planned. A separate change page showing updates and date of approval will provide an historical record to identify changes.
- e. Abbreviations - List the abbreviations and acronyms used in the ILSP.

#### 4.2.2 System Description

- a. Describe the overall system. Include a description of all components/subsystems.
- b. Describe the system software that will be used.

- c. Describe the training devices that will train maintenance and operator personnel.

#### 4.2.3 Program Management

Identify the ILS manager. Identify all participating organizations, including other agencies and countries. Specify the ILS management team (ILSMT).

#### 4.2.4 Applicable Documents

Identify documents providing guidance, parameters, performance characteristics, and other criteria for functions and requirements described in the ILSP.

### 4.3 CONTENT OF SECTION II - PLANS, GOALS, AND STRATEGY

- 4.3.1 Mission Need Statement - Describe the Mission Need Statement in terms of the mission to be accomplished. Identify agency components to be involved in the mission and their roles and responsibilities.
- 4.3.2 Acquisition Strategy - Describe the anticipated acquisition approach. Define contractual approaches and incentives for the areas below.
  - a. Life Cycle Cost (LCC) - Identify actions to reduce acquisition and/or operations and support (O&S) costs.
  - b. Support Risks - Identify risks associated with system support alternatives. As a minimum, the following areas will be addressed:
    - (1) What are the effects of changing the level of maintenance/repair capability?
    - (2) Are there items or subsystems in the inventory that can be used to reduce development risk/requirements?
    - (3) How will the proposed system be integrated into the NASA integrated logistics support system?
  - c. Sustaining Engineering - Describe actions to reduce requirements for a high level of sustaining engineering to operate and maintain the system.
  - d. Source Selection - Describe how ILS and supportability will be addressed in the source selection process. Include any plans to consider estimated cost of operations and support, in addition to anticipated acquisition cost, when making the source selection evaluation.

- e. Reliability, Availability, and Maintainability (RAM) - Identify actions to provide incentive to reduce potential LCC, increase system reliability, and reduce maintenance requirements.
- f. Transportability - Describe what efforts have been made to assure that the system is engineered to be transportable by a standard transportation mode.
- g. Other Data - Include any other acquisition strategy data as it relates to the ILS program.

#### 4.3.3 LSA Strategy

Describe the LSA strategy to be used in the acquisition effort. The LSA effort will be tailored to the unique characteristics of each payload. Tailoring is accomplished by selecting applicable LSA tasks and subtasks. Table 4-1 lists the LSA tasks and task descriptions.

#### 4.3.4 Supportability Test and Evaluation

Briefly describe the planned supportability test and evaluation concept, scope, and objectives.

#### 4.3.5 ILS Element Plans

Subordinate logistics plans will be developed for specific logistics areas. The content of these plans will be addressed in this paragraph.

##### a. Maintenance Plan

This plan provides the integrated planning and analysis process which addresses the requirement to assess the design as it relates to maintenance and the development of maintenance requirements.

Table 4-1 LSA TASKS

<u>Task #</u>	<u>LSA Tasks</u>	<u>Task Description</u>
101	Development of an Early Logistics Support Analysis Strategy	Identifies the LSA tasks which will provide the best return on investment.
102	Logistics Support Analysis Plan	Describes and documents the ILS program, authority and management structure and states what tasks are to be performed and who will be responsible for performing the task.
103	Program and Design Reviews	Provides for timely LSA program participation in official review and control of payload design.
201	Use Study	This task identifies pertinent support factors related to the intended purpose of the payload.
202	Mission Hardware, Software, and Support System Standardization	Defines the support and support related design constraints based on support commonality/standardization considerations.
203	Comparative Analysis	Defines an analytical foundation for projecting supportability requirements, identifies cost drivers and documents risk involved in using analytical data.
204	Technological Opportunities	Identifies technological advances and state of the art approaches to supportability.
205	Supportability and Supportability Related Design Factors	Establishes quantitative support characteristics of alternate design and operational concepts, support design objectives, goals, constraints and thresholds.

Table 4-1 LSA TASKS (Concluded)

<u>Task #</u>	<u>LSA Tasks</u>	<u>Task Description</u>
301	Functional Requirements Identification	This task identifies the operations and support functions that will be performed for each alternative and identifies the tasks that will be performed to operate and maintain the system in its intended environment.
302	Support System Alternatives	Establishes the support system alternatives for evaluation and tradeoff analysis.
303	Evaluation of Alternatives and Tradeoff Analysis	This task determines the preferred support system alternative for each system, the best approach and the best balance between risk, cost, schedule, performance and support efficiency.
401	Task Analysis	Analyze required operations and maintenance tasks for the new payload.
402	Early Fielding Analysis	Assess the impact of introduction of the new payload on the existing logistics system.
403	Post-Production Support Analysis	Analyze life-cycle support requirements of the payload prior to the closing of any production lines.
501	Supportability Test, Evaluation and Verification	Assess the achievement of supportability parameters specified, identify reasons for deviation and recommend changes to correct deficiencies.



b. Logistics Support Personnel and Training Plan

This plan contains qualitative and quantitative information for use by responsible management agencies to identify maintenance personnel requirements by numbers, skills, other qualifications, and training requirements.

c. Supply Support Plan

This plan describes the processes for meeting the spare and repair parts requirements. The plan will specifically address provisioning procedures and requirements. Also, the plan will address the use of the LSA process and the maintenance plan in the development and definition of spare and repair parts requirements.

d. Support Equipment Plan

This plan identifies and provides common support equipment and software requirements necessary to accommodate organizational, intermediate, and depot-level maintenance.

e. Technical Data and Documentation Plan

This plan provides the technical data and the documentation planning which prescribes general procedures, terms, and conditions for planning, preparation, and delivery of technical data required for training, maintenance, and operational support of equipment.

f. Logistics Facilities Plan

This plan provides the facilities planning which includes the facilities and equipment required to support maintenance, training, storage, and installation and checkout.

g. Logistics Information System Plan

This plan addresses those data elements, files, reports, and associated hardware and software that provide for status, historical data, trends, management visibility, accountability, performance evaluation, control and allocation of logistics resources.

h. Packaging, Handling, Storage, and Transportation Plan.

This plan addresses the procedures and resource requirements necessary to insure that all system equipment and support items are transported, preserved, packaged, stored and handled properly.

4.4 CONTENT OF SECTION III - ILS MILESTONE SCHEDULE

This section will contain a realistic milestone schedule which shows specific ILS program tasks and events. Figure 4-1 shows a typical integrated logistics support schedule.

ILSP SECTION REFERENCE	TASK DESCRIPTION	RESPONSIBILITY	FY			FY			FY			FY			FY		
	ILS Plan o ILSMT Identification LSA Tasks Maintenance Plan Personnel and Training Plan Supply Support Plan o Provisioning Plan o Provisioning Conference Support Equipment Plan Packaging, Handling, Storage, and Transportation Plan Logistics Facilities Plan Logistics Information System Plan Technical Data and Documentation Plan																

AR-87-188

Fig. 4-1 Typical Integrated Logistics Support Schedule

#### 4.5 ANNEXES

Include any detailed plans or other information as needed to support any portion of Sections I and II as annexes to this plan.

## GLOSSARY

Commonality - The use of identical or similar hardware, software, standards, and technical approaches to satisfy multiple sets of functionally similar requirements.

Depot - Facility for performing maintenance on material requiring major overhaul or a complete rebuild of parts, assemblies, subassemblies, and end-items, including the manufacture of parts, modifications, testing, and reclamation as required.

Integrated Logistics Support (ILS) - A disciplined approach to the activities necessary to: (a) cause support considerations to be integrated into system and equipment design; (b) develop support requirements that are consistently related to design and to each other; (c) acquire the required support; and (d) provide the required support during the operational phase at minimum cost.

Integrated Logistic Support Management Team (ILSMT) - A management group responsible for monitoring the ILS process for a given system or payload to ensure adherence to the requirements in the ILS Plan.

Integrated Logistic Support Plan (ILSP) - The plan developed to incorporate all elements of ILS for the life of a system.

Inventory Management System (IMS) - The means by which assets are identified and controlled. The system organizes, manages, and controls the spares, equipment/consumables and other materials needed to ensure the support of systems/subsystems in accomplishing their mission.

Life Cycle Cost (LCC) - The total cost of a system from its inception to its retirement.

Logistics Management Information System (LMIS) - A system that provides the essential management visibility to ensure timely and cost-effective accomplishment of logistics requirements. The main elements are logistics schedules and status reports which will provide a basis for evaluating logistics performance.

Logistic Support Analysis (LSA) - The selective application of scientific and engineering efforts undertaken during the acquisition process, as part of the system engineering and design process, to assist in complying with support-ability and other ILS objectives.

Logistic Support Analysis Record (LSAR) - That portion of LSA documentation consisting of detailed data pertaining to the identification of logistic support resource requirements of a system/equipment.

Long-lead Item - An item, which, because of its complexity of design, complicated manufacturing process, or limited production capacity, causes production or procurement cycles which would preclude timely or adequate delivery, if not ordered in advance of normal provisioning.

Maintainability - The measure of the ability of an item to be retained in or restored to specified condition when maintenance is performed by personnel having specified skill levels, using prescribed procedures and resources, at each prescribed level of maintenance and repair.

Maintenance - All action taken to retain materiel in or to restore it to a specified condition. It includes: inspection, testing, servicing, classification as to serviceability, repair, rebuilding, and reclamation.

Mission Need Statement - A clear, concise description of a specified task, its requirements, and its purpose.

Operations and Support (O&S) Costs - The cost of operation, maintenance, and follow-on logistics support of the end items and their associated support systems.

Orbital Replaceable Unit (ORU) - Any assembly that can be removed and replaced as a unit from an on-orbit system.

Packaging, Handling, Storage, and Transportation (PHS&T) - The resources, processes, procedures, design considerations and methods to ensure that all system equipment and support items are preserved, packaged, handled, and transported properly. This includes environmental considerations and equipment preservation requirements for short and long term storage, and transportability. This is one of the principal elements of ILS.

Parts Screening - Process of assigning National Item Identification Numbers (NIINs) to items to prevent duplicate items from entering the defense supply system.

Phase A - Preliminary analysis to identify and explore alternate concepts to satisfy a validated need.

Phase B - The definition phase when selected candidate solutions are refined through extensive study and analysis.

Phase C - The design phase which includes the detailed definition of the final objectives and project concept.

Phase D - The development/operations phase which covers final hardware design and development, fabrication, test, and project operations.

Provisioning - The process of determining and acquiring the range and quantity (depth) of spares and repair parts, and support and test equipment required to operate and maintain an end item of materiel for an initial period of service.

Reliability - The duration of probability of failure-free performance under stated conditions.

Repair Level Analysis (RLA) - A process for recommending repair levels of units, assemblies, and subassemblies which will accrue minimum total support costs within operational and technical constraints over the system design life. It forms the basis for assigning repair level; repair versus discard-at-failure decision; repair parts provisioning; and Source, Maintenance, and Recoverability (SMR) coding, maintenance planning, and documentation.

Repair Parts - Those support items that are an integral part of the end item or system which are coded as nonreparable.

Source, Maintenance, and Recoverability (SMR) Codes - Uniform codes assigned to all support items to convey maintenance and supply instructions to the various logistics support levels. They are assigned based on the logistic support planned for the end item and its components. The uniform code format is composed of three, two character parts; Source Codes, Maintenance Codes, and Recoverability Codes in that order.

Spares - Those support items that are an integral part of the end item or system which are coded as repairable.

Support Requirements Analysis (SRA) - An analysis accomplished during the system design to establish logistics support requirements. The analysis is a step-by-step process of predicting operational and maintenance activities, and defining and documenting the required resources.

Supply Support - All management actions, procedures, and techniques used to determine requirements to acquire, catalog, receive, store, transfer, issue, and dispose of secondary items. This includes provisioning for initial support as well as replenishment supply support. This is one of the principal elements of ILS.

Supportability - The degree to which system design characteristics and planned logistics resources, including manpower, meet system readiness and utilization requirements.

Support Equipment - All equipment required to support the operation and maintenance of a system. This includes associated multiuse end items, ground-handling and maintenance equipment, tools, test equipment, and automated test equipment. It includes the acquisition of logistics support for the support and test equipment itself. This is one of the principal elements of ILS.

Sustaining Engineering - The on-going engineering process of maintaining and operating a system once it is deployed. This process continues throughout the life of the system.

Test, Measurement, and Diagnostic Equipment (TMDE) - Equipment used to determine the operability of system hardware and support equipment.

Technical Data Package - Recorded information regardless of form or character (e.g., manuals, drawings) of a scientific or technical nature for a given system. Computer programs and related software are not technical data; documentation of computer programs and related software are. Also excluded are financial data or other information related to contract administration. This is one of the principal elements of ILS.

Transportability - The inherent capability of materiel to be moved with available and projected transportation assets to meet established schedules.



S4-12

12453/  
159

PRELIMINARY ANALYSIS  
OF AN  
INTEGRATED LOGISTICS SYSTEM  
FOR  
OSSA PAYLOADS

N88-19481

Volume IV

Supportability Analysis of  
The 1.8m Centrifuge

T. Palguta, W. Bradley and T. Stockton  
Lockheed  
Huntsville Engineering Center

Contract Number NAS8-32697

April 1987

George C. Marshall Space Flight Center  
National Aeronautics and Space Administration  
Huntsville, AL 35812

PRECEDING PAGE BLANK NOT FILMED

## 1.0 INTRODUCTION

### 1.1 PURPOSE

This document addresses supportability issues for the 1.8 M centrifuge in the Life Science Research Facility. The analysis focuses on reliability and maintainability and the potential impact on supportability and affordability.

### 1.2 SCOPE

This analysis was performed in support of the Office of Space Science and Applications (OSSA) effort to incorporate integrated logistics support in all facets of their various payload programs. This analysis outlines standard logistics engineering methodologies that will be applied to all OSSA payload programs. These methodologies are applied to the 1.8 M centrifuge. Additionally, the importance of specified operational requirements are highlighted. They are the basis for establishing system design requirements.

The centrifuge is only one of several major pieces of equipment intended to form the nucleus of the specimen holding and management facility. Specimen habitats must fit all elements: Habitat Holding Unit; 1.8 and 3.75 M Centrifuges; Multipurpose Work Bench; Equipment Cleaner; possibly others. Significant supportability issues will arise in areas of

reliability, maintainability and commonality which, if resolved, could affect significant operational and logistics savings. The current Supportability Analysis approach should be applied to the entire specimen holding and management facility.

1.8 M Centrifuge designs now exist only at the level of conceptual design, but specific logistics concerns, which must be addressed in depth during upcoming Phase B Definition and Preliminary Design Studies, can already be identified.

## 2.0 OBJECTIVES AND REQUIREMENTS

### 2.1 OBJECTIVES

The science objectives for the 1.8 M centrifuge are as follows:

- o Evaluate the requirements for artificial gravity during long duration human space missions.
- o Assess the impacts of long-term fractional gravity associated with future lunar and Mars bases.
- o Determine the role of gravity in basic biological processes.
- o Provide a controlled acceleration environment for unambiguous and thorough life science studies of microgravity.
- o Provide a 1-G environment to supply a source of specimens that are thoroughly adapted to the spacecraft environment prior to experimental use.

These objectives are based on the NASA White Paper: Research Centrifuge Requirements for the Space Station, NASA ARC, June 1986. Figure 2-1 shows a drawing of the 1.8 M centrifuge.

### 2.2 REQUIREMENTS

The requirements for the 1.8 M centrifuge are listed in Table 2-1 through 2-4. These requirements are based on the following documents:

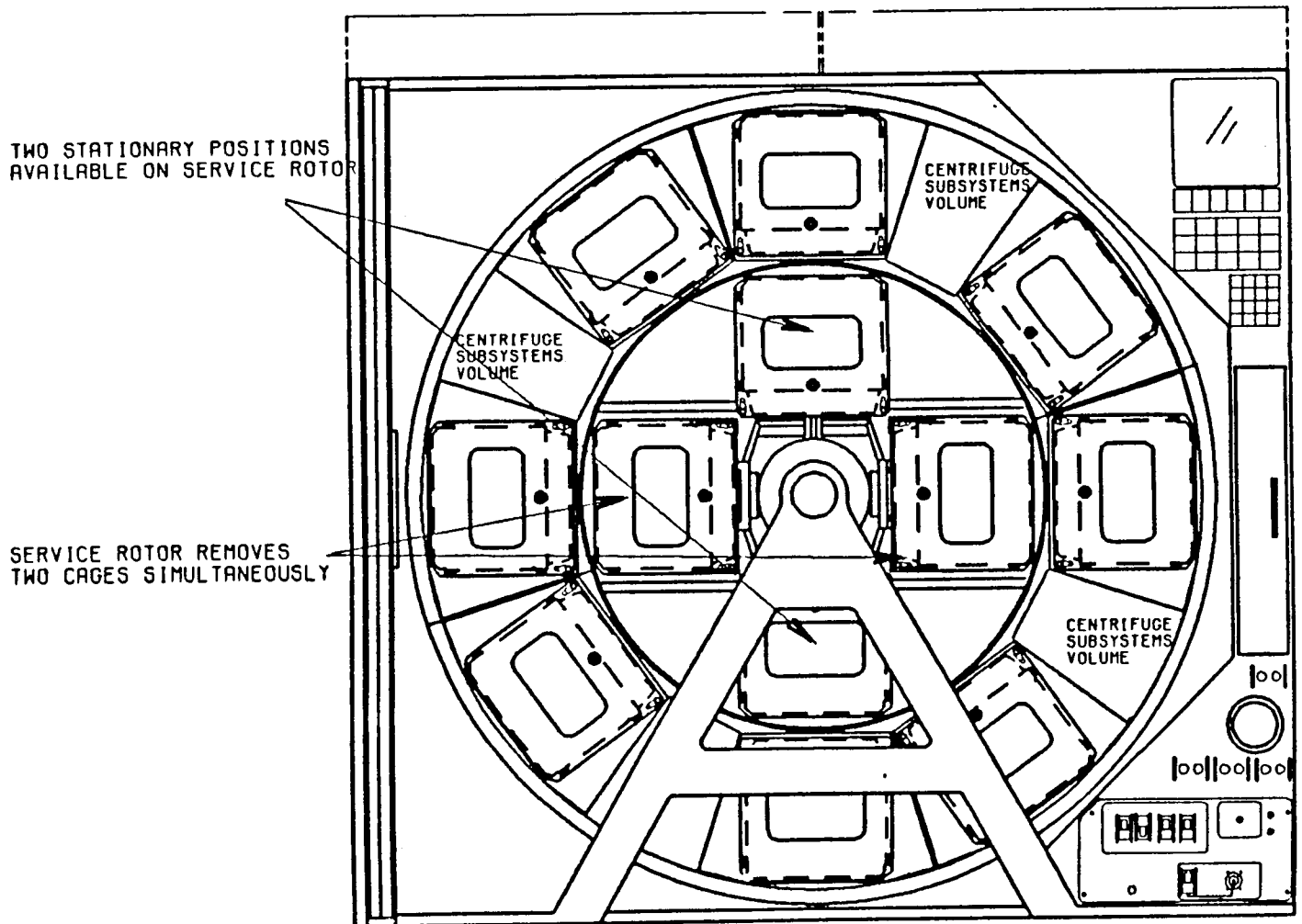

Fig. 2-1 Drawing of 1.8 M Centrifuge

- o Red Book: A Reference Payload for the Life Science Research Facility, TM 89188, August 1986
- o White Paper: Research Centrifuge Requirements for the Space Station, NASA ARC, June 1986.
- o Space Station Program Definition and Requirements Document (PDRD), JSC 30000
- o Derived Requirements

Table 2-1 SYSTEM REQUIREMENTS

- o Create artificial gravity to support science research.
- o Main rotor accommodate small plants and rodents and their consumable supplies.
- o Provide for power and data transfer across rotating hub.
- o Secondary rotor and service robot retrieves and replaces experiment packages.
- o Secondary rotor accommodates short-term experiments.
- o Counterrotating inertia wheel automatically compensates for torque and momentum generated by main and secondary rotors.
- o Automatic balancing system.

C-2

Table 2-2 REQUIREMENTS IMPOSED BY SCIENCE USERS

- o Create  $\leq 10^{-3}G$  variation in G-level onboard the centrifuge.
- o Provide automated servicing capability to retrieve and replace experiment packages.
- o Monitor and control each experiment package.
- o Provide necessary utilities to each experiment package.
- o Accommodate modular equipment which is functionally shared with holding facilities, workstation, equipment washer, and other science equipment.
- o Monitor and control centrifuge operating parameters.

Table 2-3 SCIENCE REQUIREMENTS

- o Create .001 G to 2.0 G at the centrifuge perimeter.
- o Accelerate at rates from .01 Gs to .25 Gs.
- o Maintain live specimens in a healthy and stress-free environment.
- o Accommodate small plants and rodents.
- o Rotate continuously.

Table 2-4 DESIGN REQUIREMENTS IMPOSED BY SPACE STATION PROGRAM

- o Emit  $\leq 10^{-5}G$  vibration to the Space Station.
- o Operate below acoustic limit.
- o Meet electromagnetic interference requirement.
- o Compensate torque and momentum with a 3% residual.
- o Design for a life of 25 years with periodic servicing.
- o Enclose centrifuge in a safety, acoustical, and visual barrier.
- o Monitor and control centrifuge system operating parameters.
- o Provide for on-orbit integration or relocation within the pressurized modules.
- o Allow access to pressurized module shell.
- o Orient centrifuge spin axis along the Space Station Y-axis to minimize gyroscopic torques.



### 3.0 SUPPORTABILITY ISSUES

#### 3.1 GENERAL

A preliminary analysis of the 1.8 M centrifuge has identified several supportability issues. This document does not address all supportability issues, but discusses the salient issues that a logistics engineer would address in this phase of system acquisition for the centrifuge and the Life Science Research Facility. During Phase B of the acquisition cycle, the logistics engineer focuses on design influence to reduce future support requirements and costs. The logistics engineer interfaces with the design engineer and the systems engineer to discuss and resolve the issues.

#### 3.2 RELIABILITY

Reliability requirements for the centrifuge are general in nature, i.e., design for a life of 25 years with periodic servicing, and rotate continuously. The requirement to rotate continuously is imposed because some experiments require specimens to be exposed to continuous gravity over the duration of the experiment. Unscheduled servicing would compromise experimental results. If unscheduled maintenance is not acceptable, then the specifications should clearly state this. This would drive designers to make all critical components in the centrifuge redundant. Figure 3-1 is a

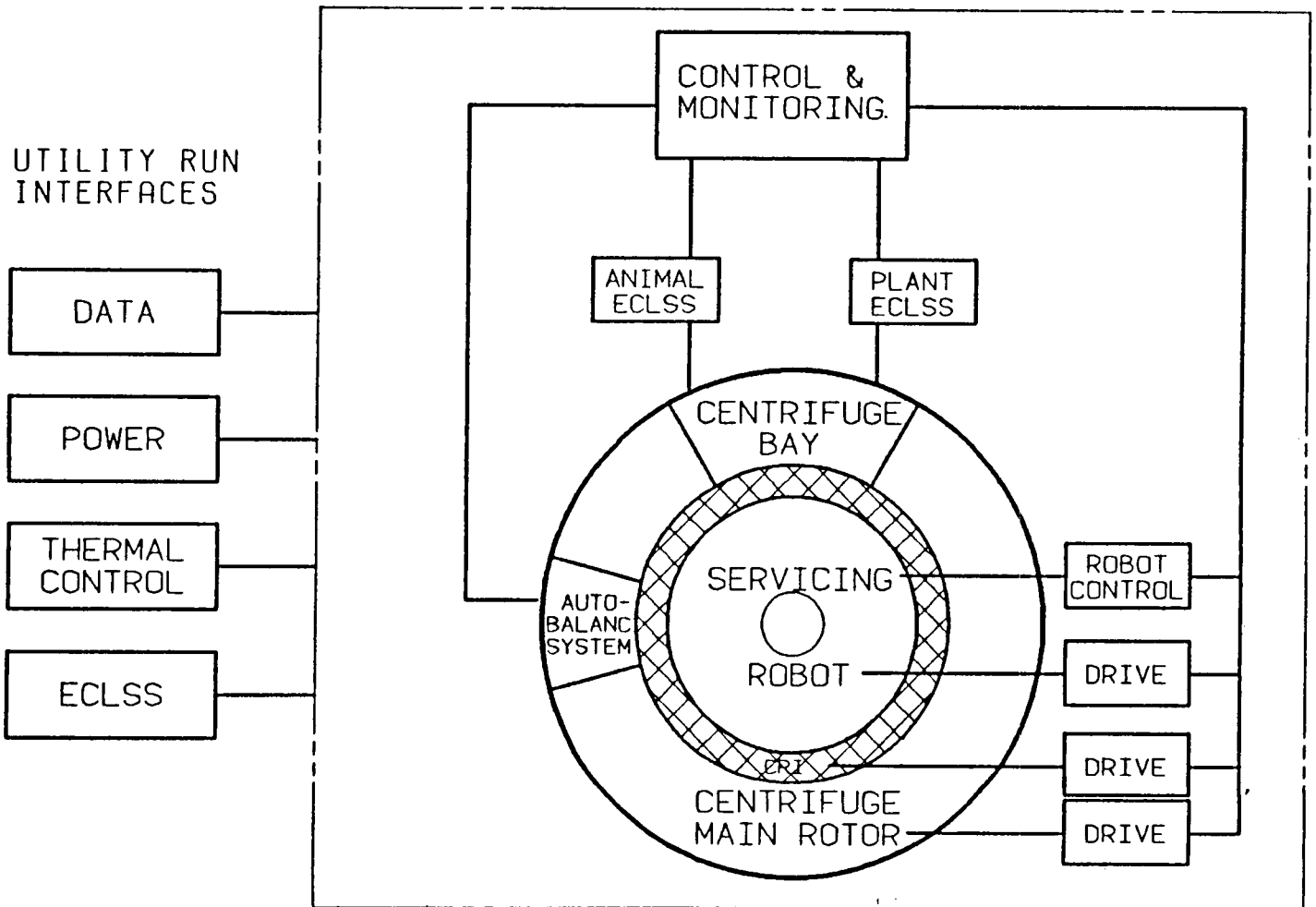

Fig. 3-1 Schematic of 1.8 M Centrifuge

Table 3-1 COMPONENT/SYSTEM MTBF

Component MTBF (Yrs)	Resulting System MTBF (Yrs)
25	2.8
20	2.2
15	1.7
10	1.1
5	0.6
4	0.44
3	0.33
2	0.22
1	0.11

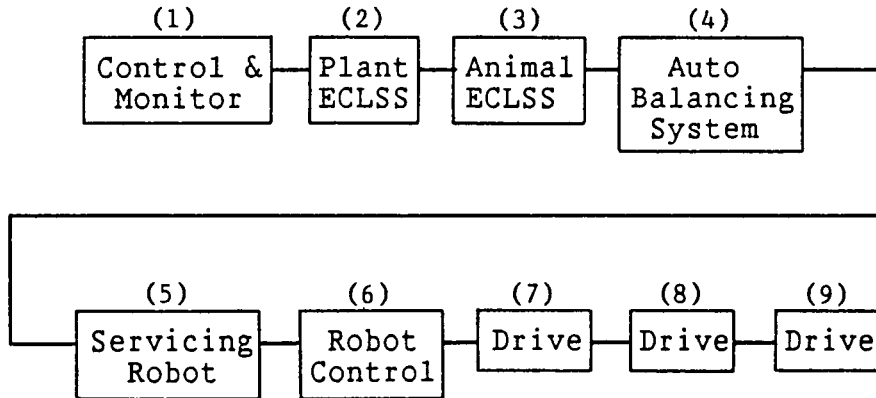

Fig. 3-2 Series Relationship

schematic of the 1.8 M centrifuge. The schematic shows nine system components. A cursory analysis indicates that all nine components must operate for mission success criteria to be met. Since there is no redundancy of these functions, it yields a series reliability network. Figure 3-2 shows the series relationship. Any component failure brings the entire system down. Table 3-1 shows the system sensitivity to a series relationship of this nature. If component Mean Time Between Failure (MTBF) is 25 years, the resulting system MTBF would be 2.8 years. If the system components are designed with a MTBF of 4 years, the system would have an MTBF of .44 years, or less time than is required to complete an experiment. The resulting unscheduled maintenance requirements would seriously impact mission accomplishment. Design of the centrifuge will require component redundancy to ensure mission success.

### 3.3 MAINTAINABILITY

Maintainability is a key design consideration for the 1.8 M centrifuge. All critical components within the centrifuge will be functionally packaged and designed as ORUs. The centrifuge will incorporate BIT/BITE to isolate failures to the ORU level. On-orbit repair of centrifuge ORUs will be analyzed. If centrifuge ORUs are chosen for on-orbit repair, then they will be designed to be tested with test equipment that is available on the Space Station. Test equipment will isolate failures to the subassembly level, and spares will be available on the Space Station. The capability to replace failed ORUs while the centrifuge is operating will be analyzed in

conjunction with required/available on-board storage space. Other maintainability considerations are training and technical data requirements. These considerations will be applied to all candidate subsystems and incorporated as design requirements. A specific example is the ball bearing suspension system that has been chosen as the leading option for the suspension system. The ball bearing system requires that its oil system be serviced at a 5-year interval. The logistician will assess the impact on support equipment requirements, skills required to perform the servicing, time required to perform the tasks, and contamination or other hazards involved.

#### 3.4 COMMONALITY

Commonality in design will be emphasized to reduce logistics requirements and cost. The current centrifuge concept requires three drive motors, one for each of the rotors: the main rotor, the service rotor, and the compensator. Each motor is different due to different torque requirements. No motor redundancy is planned. Designers should look at the possibility of common motors. Commonality of design should also be considered for the power transformers and optical couplers. All standardization achieved will improve supportability of the centrifuge.

Intensive supportability analyses paralleling, and coupled to, Phase B 1.8 M centrifuge system definition and preliminary design studies will penetrate these and other potential problems in detail and in depth. They will provide the program manager with logistics planning tools to ensure the successful development and operation of the centrifuge. If, as seems

likely, NASA develops the core group of specimen habitats, centrifuges, a multipurpose workbench, specimen husbandry devices and equipment cleaning hardware as a single development entity, then simultaneous, integrated, indepth supportability analyses of these payload elements will constitute an essential early step in the Life Sciences Research Facility program.

#### 4.0 SUMMARY

The preliminary supportability analysis of the 1.8 M centrifuge has identified several key issues. All of the supportability issues have a tremendous impact on the logistics support requirements and support costs for the centrifuge. An integrated logistics support program and plan will be developed as an integrated effort with the design process. Lack of a clearly defined program could hinder the integration and support of the centrifuge and other life science equipment. Logistics engineers will interface with design and systems engineers to resolve the supportability issues. Reliability, maintainability, and commonality are interrelated and have a major impact on required logistics support in terms of skills and levels of maintenance personnel required, spares stockage, support equipment required, personnel training, and associated operations and support costs. Trade studies will be employed to obtain an optimum balance between cost and effectiveness. The trade studies will analyze reliability, maintainability, and commonality interaction and associated life-cycle cost. The centrifuge and the entire Life Sciences Research Facility are currently in a critical phase of development. The decisions made now will dictate future support requirements and costs. These requirements and costs can be minimized with an effective Integrated Logistics Support program.

1. REPORT NO. NASA CR-4114		2. GOVERNMENT ACCESSION NO.		3. RECIPIENT'S CATALOG NO.	
4. TITLE AND SUBTITLE Preliminary Analysis of an Integrated Logistics System for OSSA Payloads				5. REPORT DATE February 1988	
				6. PERFORMING ORGANIZATION CODE	
7. AUTHOR(S) T. Palguta, W. Bradley, and T. Stockton				8. PERFORMING ORGANIZATION REPORT # LMSC-HEC TR D066015	
9. PERFORMING ORGANIZATION NAME AND ADDRESS Lockheed Huntsville Engineering Center Huntsville, Alabama				10. WORK UNIT NO. M-581	
				11. CONTRACT OR GRANT NO. NAS8-32697	
				13. TYPE OF REPORT & PERIOD COVERED Final Contractor Report Sept 15, 1986 - Apr 15, 1987	
12. SPONSORING AGENCY NAME AND ADDRESS National Aeronautics and Space Administration Washington, D.C. 20546				14. SPONSORING AGENCY CODE	
15. SUPPLEMENTARY NOTES Technical Monitor: Dr. John Hilchey, Program Development, George C. Marshall Space Flight Center, Marshall Space Flight Center, Alabama 35812					
16. ABSTRACT  This combined volume details the results of study of OSSA's need for an integrated logistics system to support OSSA payloads, whether attached to the Space Station or free-flying. The four sub-volumes comprising this volume are:  <u>Vol. I - Executive Summary</u> - Describes the study background rationale and approach and provides a brief summary of results. <u>Vol. II - OSSA Integrated Logistics Support Strategy</u> - Describes a strategy for OSSA logistics support of its payloads, methods for its implementation, and the logistics tasks which require analysis to support development of the OSSA Integrated Payload Logistics Program. <u>Vol. III - OSSA Integrated Logistics Support Planning Document</u> - Establishes procedures for preparing Integrated Logistics Support Plans specific to the needs of OSSA payload programs. <u>Vol. IV - Supportability Analysis of the 1.8m Centrifuge</u> - Provides a specific example of a document on which logistics relies heavily. This preliminary analysis addresses supportability issues for the 1.8m centrifuge in OSSA's Life Sciences Research Facility, focusing on reliability and maintainability of long-life research equipment items and the impact of these factors on equipment supportability and its costs.					
17. KEY WORDS OSSA Payloads                      Centrifuge Logistics Integrated Logistics Logistics Support Supportability Analysis LSRF				18. DISTRIBUTION STATEMENT Unclassified - Unlimited Subject Category: 12	
19. SECURITY CLASSIF. (of this report) Unclassified		20. SECURITY CLASSIF. (of this page) Unclassified		21. NO. OF PAGES 109	22. PRICE A06

For sale by National Technical Information Service, Springfield, Virginia 22161

NASA-Langley, 1988