

**NASA
Technical
Paper
2803**

March 1988

Investigation of the Misfueling of Reciprocating Piston Aircraft Engines

J. Holland Scott, Jr.

(NASA-TP-2803) INVESTIGATION OF THE
MISFUELING OF RECIPROCATING PISTON AIRCRAFT
ENGINES (NASA) 82 p CSCL 910

N88-21144

Unclass

81/03 0140732

NASA

**NASA
Technical
Paper
2803**

1988

Investigation of the Misfueling of Reciprocating Piston Aircraft Engines

J. Holland Scott, Jr.

*Goddard Space Flight Center
Wallops Flight Facility
Wallops Island, Virginia*

NASA

National Aeronautics
and Space Administration

Scientific and Technical
Information Division

TABLE OF CONTENTS

PREFACE.....	v
INTRODUCTION.....	1
DESCRIPTION OF THE PROBLEM.....	1
TEST DESIGN PHILOSOPHY.....	4
EVAPORATION TEST.....	5
GAS CHROMATOGRAPH TEST.....	8
CONCLUDING REMARKS.....	10
APPENDIX A - Evaporation Test Data Summary.....	A-1
APPENDIX B - REFERENCES.....	B-1
APPENDIX C - Development of a Test Kit to Detect Jet Fuel Contamination of Avgas (ATTACHMENT A).....	C-1
APPENDIX D - Modification to a Gas Chromatograph to Detect Jet Fuel Contamination of Aviation Gasoline (ATTACHMENT B).....	D-1

PRECEDING PAGE BLANK NOT FILMED

PREFACE

The investigation of the inadvertent misfueling of general aviation aircraft described in this report was conducted under certain policies adopted by the National Aeronautics and Space Administration (NASA) as a part of its charter. One of these policies states that the scientific technology developed as a result of the agency's operation shall be transferred to the user community for the benefit of mankind. Publication of this document represents the transfer of this information to the general aviation community and resolution of the agency's commitment. Reports from two private companies, who were employed to develop prototype instruments after a successful design concept was demonstrated, are included in this document. Both reports are published in their entirety to facilitate the readers comprehension of the project.

The Aircraft Misfueling Detection Project was managed by the Aeronautical Projects Section, Suborbital Projects and Operations Directorate; Goddard Space Flight Center/Wallops Flight Facility, Wallops Island, Virginia. Financial management was provided by the Chief Engineer's Office, NASA Headquarters, Washington, D.C. Support contractors for this investigation were the Aircraft Owners and Pilots Association (AOPA), Frederick, Maryland, and GOW-MAC Instrument Co., Bridgewater, New Jersey. Appreciation for their cooperation is gratefully acknowledged.

The author would like to thank all those who contributed to this effort, especially the task force steering committee for their conscientious guidance. Mr. Fred Quarles, an active AOPA member, deserves grateful recognition for his suggestion that jet fuel detection may be determined by use of the evaporation method. The Petroleum Testing Laboratory at the Norfolk Naval Supply Station, Norfolk, Virginia, tested our contamination samples to determine octane degradation, for which we are very appreciative.

Katherine Hooks, a most efficient Chemal, Inc. laboratory technician, spent many hours processing fuel samples and providing other valuable support. The enthusiasm she exhibited and her contributions to the project merit the special recognition of the author.

PRECEDING PAGE BLANK NOT FILMED

INVESTIGATION OF THE MISFUELING
OF
RECIPROCATING PISTON AIRCRAFT ENGINES

J. Holland Scott, Jr.
NASA Goddard Space Flight Center
Wallops Flight Facility
Wallops Island, VA 23337

INTRODUCTION

The General Aviation Manufacturers Association (GAMA) and the American Petroleum Institute (API) convened a task force of industry and government representatives in Washington, D.C. during November, 1982. The group was charged with investigation of the rapidly increasing problem of inadvertent misfueling of general aviation aircraft. More specifically, the problem involved the introduction of jet fuel (either unadulterated or as a mixture with aviation gasoline) into a reciprocating piston aircraft engine. Designed solely for use of aviation gasoline (avgas), such engines are intolerant of jet fuel, often resulting in destruction of the engine and catastrophic aircraft crashes. The potential for injury, death, and equipment damage in these situations is unusually high.

This report contains the results of NASA's participation in the task force activities.

DESCRIPTION OF THE PROBLEM

From 1970 through 1981 there were 54 reported accidents related to improper fuel grade that occurred in the continental United States. Thirteen of these accounted for 34 fatalities and 43 serious injuries. Half involved privately owned aircraft, but 22 percent involved corporate/executive or air taxi operations. In four of the above accidents total pilot flight time in fixed-wing aircraft ranged from 4352 to 25871 hours. Of the four pilots, two had air transport ratings, one was a commercial flight instructor, and one was a private pilot. Aircraft misfueling accidents, as the profile indicates, can and do involve a wide cross section of pilots regardless of experience.

The task force of industry and government representatives, after reviewing these alarming statistics, organized a concerted effort to reduce the potential for misfueling general aviation aircraft. The result was promotion of innovative devices and methods such as fuel identification decals, banded fuel nozzles, fuel

filler pipe restrictors, oversize jet fuel nozzles, standard refueling procedures, and educational/awareness training programs. NASA, currently engaged in preliminary work on the problem, elected to develop specific tests to identify contaminated fuel prior to its consumption in a reciprocating piston aircraft engine.

Typically, many accidents related to misfueling happen during take-off under maximum power as the reciprocating piston engine is exposed to high stress conditions and as damage to the engine occurs. As a result of consuming contaminated fuel there is seldom sufficient time or altitude after engine damage commences to take evasive action to avoid a crash, a factor that probably contributes to the high fatality rate associated with incidents of this type. There have also been incidents where aircraft were misfueled but fortunately the error was discovered in time to prevent mishap. Incidents of these types, for the most part, go unreported, therefore the misfueling problem is more widespread than statistics tend to imply.

Misfueling often results from carelessness or ignorance and quite often flightline personnel are involved. A typical example is the reciprocating piston engine DC-3 that crashed while departing a St. Louis airport after being misfueled. Failing to start an avgas refueler the flightline attendant mistakenly started a jet refueler and pumped jet fuel into the aircraft resulting in one fatality and one serious injury. A similar accident occurred at Salisbury, Maryland when an Aero Commander 500B crashed on take-off killing all five persons aboard. The flightline attendant had

refueled with only a small amount of jet fuel, but enough to cause the aircraft to crash.

Jet fuel contamination of avgas can easily occur before the fuel reaches the flightline. Generally, refineries maintain high standards of quality control over their products and formerly, the major fuel processors delivered fuel directly to the flightline and, on occasion, to the waiting aircraft. This control of their product is now placed in the hands of transport companies that pick up the products at the refinery and transport them to local area distributors. These distributors then transport the fuel to the airport where it is placed in storage to be transported to the flightline in refuelers by flightline personnel. The potential for contamination of avgas exists at many points in the transportation process and increases with more frequent handling of the fuel.

The jet engine, unlike the reciprocating piston engine which requires avgas, operates on a less costly, more efficient, kerosene base fuel. With the advent of the jet engine, fixed-base operators (FBO's) who previously refueled aircraft exclusively with avgas are now dispensing both fuels simultaneously. Thus the potential for inadvertently mixing the two fuels is increasing with greater jet fuel usage. The jet fuel contaminant causes a highly destructive process known as "detonation" when the mixture is consumed in a reciprocating piston engine.

The effect of consuming jet fuel in a reciprocating piston engine is both rapid and destructive. During the compression stroke of a spark ignition engine the

pressure, density, and temperature are increased. The mixture is ignited by an electrical spark after a proper delay time. The flame front created by ignition travels across the combustion chamber at a more or less orderly rate as pressure rises uniformly. Ahead of the flame front the unburned mixture is compressed by the rising pressure with a corresponding rise in temperature and density. Injection of jet fuel as a contaminant alters the ignition point of the unburned gas so that it ignites before the flame front arrives. The result is autoignition within the unburned gases in advance of the approaching flame front. The orderly process becomes uncontrolled and a violent pressure rise occurs. Energy is released at such a high rate that the walls of the chamber vibrate. This phenomena is known as detonation and is analogous to the more familiar "knocking" in an automotive engine. It can become so extreme as to cause catastrophic destruction of the combustion chamber with subsequent engine failure.

Contamination of avgas by jet fuel also results in a decreased octane rating when compared with pure avgas. Therefore, the degradation was used as a baseline with which the test data derived from this experimentation could be related. It must be emphasized that this was not an attempt to evaluate the

tolerance of a reciprocating piston engine for contaminated fuel.

The Petroleum Testing Laboratory at the Norfolk Naval Supply Station in Norfolk, Virginia, analyzed fuel samples to assist in evaluation of the extent of degradation at various contaminations. The Petroleum Testing Laboratory used a standard laboratory knock engine for these tests. It contains a single cylinder, overhead valves, a two-bowl carburetor, and a continuously variable compression ratio that may be changed at will during the operation. A synchronous generator, phased to a.c. power, maintains constant speed. The two carburetor float bowls can be raised or lowered to change the fuel/air ratio. A blended fuel of known octane number, composed of n-heptane (octane number = 0) and iso-octane (octane number = 100), is placed in one bowl and the contaminated sample is placed in the other. The engine is started on the standard fuel under highly controlled conditions (temperature, air intake, spark advance, etc.). The fuel/air ratio is adjusted until maximum knock is obtained. The engine is then adjusted to a standard compression ratio and locked into position. The standard fuel is then replaced with the contaminated fuel and its octane rating is obtained from the standard knock meter on the engine. Table #1 illustrates the data obtained from this operation.

TABLE #1 OCTANE LOSS FROM CONTAMINATION

FUEL	<u>CONTAMINATION LEVEL</u>				
	1%	2%	3%	4%	5%
JET-A	* 0.9	1.8	2.6	3.6	4.7
JP-4	0.6	1.2	2.2	2.7	3.3
JP-5	1.0	1.9	2.7	3.5	4.6

* OCTANE REDUCTION

Engine manufacturers generally allow approximately 10 to 12 percent change in fuel/air ratio as a detonation margin. If this detonation margin is applied to knock limited power curves it will be found to equate to an octane loss of 2 to 3 octane numbers. That is, a loss of 2 to 3 octane numbers will use up the design safety margin and theoretically subject the engine to possible damage from detonation. Data from Table #1 indicates that a loss of 2 octane numbers is reached slightly beyond 2% contamination of avgas by jet fuel. Therefore, a detection test must be capable of identifying any heavy hydrocarbon content in excess of that found in a mixture of 2% jet fuel contamination. This criteria becomes the sensitivity requirement of the evaporation test discussed in the following section.

TEST DESIGN PHILOSOPHY

The necessity of designing separate test instruments for each of two situations became quickly evident during the early stages of this investigation. Since contamination can occur at many points along the transportation route the FBO has a valid argument for an instrument with which to exercise good quality control over his fuel handling operation and assure delivery of an uncontaminated product to the aircraft. However, not all pilots obtain fuel from an FBO and the need exists for a pilot oriented test to be performed during pre-flight tests that will assure him that he has uncontaminated fuel for flight. The pilot's test, performed on the flightline, must be quickly and easily completed in an environment

that is protected from varying flightline conditions. The FBO, however, operates in a less variable environment afforded by his hangar office. He also services a large number of pilots and these two factors justify more comprehensive testing and test equipment than those required by the pilot.

The philosophy described above led to the development of the Evaporation Test and the Gas Chromatograph Test for the pilot and the FBO, respectively. Prototype instruments were designed for the Evaporation Test by AOPA of Frederick, Maryland and for the Gas Chromatograph Test by GOW-MAC Instruments, Inc. of Bridgewater, New Jersey. The philosophy and data described in the following text were utilized in the design of these instruments. Reports from each of these companies are included in this document as ATTACHMENTS A(C-1) and B(D-1). NASA's intention is to record the results of this investigation so that the aircraft industry may benefit from its use to decrease the potential for misfueling general aviation aircraft.

Avgas and jet fuel are both composed of hydrocarbon compounds that are classified into four general types. These include paraffins, naphthenes, aromatics, and olefins; and their molecular weights vary respectively with paraffins being the lightest and most mobile. Avgas is comprised primarily of smaller, lighter hydrocarbon molecules while those of jet fuel are larger and heavier. Thus, identification of the detonation potential of jet fuel contamination in avgas becomes a factor of identifying the relative amount of the heavier compounds present. Quantitative measurement is not necessary since

pure avgas and contaminated avgas furnish unique characteristics that are easily identified by comparative analysis. In the case of the Evaporation Test, jet fuel contamination was found to retard the evaporation rate of avgas. The retardation exhibited a direct relationship to the amount of contamination present and it becomes an excellent measure of that contamination. The physical appearance of the evaporating fuel sample also takes on a unique characteristic that provides a qualitative test for contamination of avgas by jet fuel.

The Gas Chromatograph Test, similar in principle to the Evaporation Test, is a more comprehensive test requiring more sophisticated equipment but providing greater sensitivity. It utilizes the principle of preferential adsorption of hydrocarbon compounds by a selective medium. Comparative analysis of the resulting data may also be employed since pure avgas components provide entirely different adsorptive characteristics than those of avgas contaminated with jet fuel.

Other test methods such as refractometry, paper chromatography, spectrofluorimetry, digital photometry, etc. were investigated for possible use in this project. Each was eliminated in favor of evaporation (pilot's test) and gas chromatography (FBO's test) as a means of detecting jet fuel contamination of avgas. Most of the rejected methods were eliminated because of unreasonable equipment expense or increased test complexity.

Each of the two selected fuel contamination detection tests was subjected to intensive investigation in the chemistry laboratory at the Wallops Flight Facility.

The result was construction of a data base from which test sensitivity, sample size, contamination level, and environmental effects could be determined. The remainder of this document describes the manner in which that data was obtained and the recommendations that resulted from its analysis.

EVAPORATION TEST

The first evaporation tests were performed using ordinary brown kraft paper as the evaporation medium. Its universal availability and low cost were attractive for use in an inexpensive evaporation kit designed for use by pilots on the flightline. However, inconsistent results were obtained since kraft paper contains large variations in composition. Laboratory filter paper, unlike kraft paper, is produced under precise composition specifications and good quality control and though more expensive, it produced excellent results. Its use in an evaporation kit projected a considerable increase in expense. Tests were also performed on a relatively inexpensive white adding machine paper. It proved to be a very efficient alternative to those evaporation media previously tested. Data results were quite similar to those derived from the use of laboratory filter paper and it is recommended for use in a low cost evaporation kit.

Environmental testing commenced after the paper evaporation medium was established. Excessive wind conditions were found to accelerate fuel evaporation, however, short term effects of temperature (0 to 40 deg C) and relative humidity (40 to 99%) were found to have a negligible effect. The use of a closed or protected container is recommended in

Attachment A (C-3) to eliminate the effects of wind and precipitation on the kit as it is used on the flightline.

The basic Evaporation Test for contaminated fuel consists of applying a measured fuel sample to the adding machine paper and observing its evaporation. Upon initial application the wet fuel appears as a visible spot on the paper. If the sample size is large, excess fuel may appear on the inner portion of the spot. If the fuel is uncontaminated, the spot will shrink evenly to very small dimensions before it completely disappears. In contrast, if the fuel is contaminated, the spot will not shrink as evaporation occurs. Instead it will evaporate evenly over the entire area until it is no longer visible.

The second observation is the time required to complete evaporation. This is a measurable quantity and a more objective assessment of evaporation rate as a detection method. Assume that a pilot performs an evaporation test with a specific volume of an unknown sample. If the sample is pure avgas it will evaporate within a specific time. This time establishes the lower limit of an interval; the upper limit of which is the evaporation time of an

equal volume of contaminated avgas. The interval, referred to as the "detection interval" is that time after initial application during which the paper must display no visible sign of unevaporated fuel if the sample is uncontaminated. Conversely, if the sample is contaminated, visible sign of unevaporated fuel will be displayed during the detection interval. It was necessary to establish the upper and lower limits for sample size and contamination levels by laboratory analysis. A sample size range of one (0.05 ml.) to five (0.25 ml.) drops and a contamination range of one to five percent were selected to provide evaporation test design data. Fifty samples were evaporated at each combination of sample size and contamination level over the selected ranges.

The acquired data indicates that evaporation of one-drop samples produced detection levels that were too brief to identify jet fuel contamination of avgas. Some of the larger samples required more than 20 minutes to completely evaporate where high contamination levels were involved. Obviously, a test of such length is not practical for flightline operations. Small volume samples with low contamination levels evaporated much more rapidly and appear to be more practical. Figure 1 describes a typical detection interval.

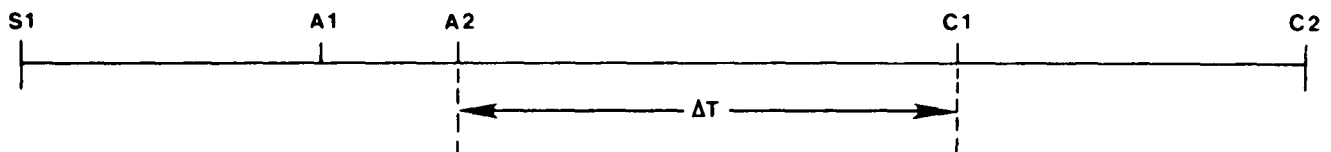

Figure 1. Typical Detection Interval

Where T = Detection Interval
 S1 = Start of Evaporation
 AlA2 = Evaporation Range for 50 Samples Avgas
 ClC2 = Evaporation Range for 50 Samples Contaminated Avgas

If any unevaporated fuel is observed at any time during the detection interval the fuel sample must be considered to be contaminated.

Pure avgas exhibited a rapid evaporation rate and a sharply defined evaporation point. Thus the data (evaporation times) were tightly dispersed about the avgas distribution mean (T_a), forming a sharply peaked distribution curve as shown in Figure 2. In contrast, contaminated fuels evaporated less rapidly and evaporation points were more subtle and difficult to define, resulting in broader distribution about the mean (T_c) and a flatter distribution curve.

These data represent a normal Gaussian distribution and, as such, contain a probability of performance and a probability of non-performance, that when added, equals one. Therefore, extending

the probability by using more than one standard deviation has the desired effect of increasing the probability of performance even though the detection interval is decreased. If the probability is extended to + or - five standard deviations (99.9999%) then the probability of non-performance becomes 0.000001% (1/1000000). Applying this logic (as shown in Figure 2) allows the selection of a time differential that is a detection interval (P5) with a reasonable risk of non-performance (failure to identify contaminated fuel) that is acceptable to the general aviation community. The following equation was derived to evaluate detection intervals:

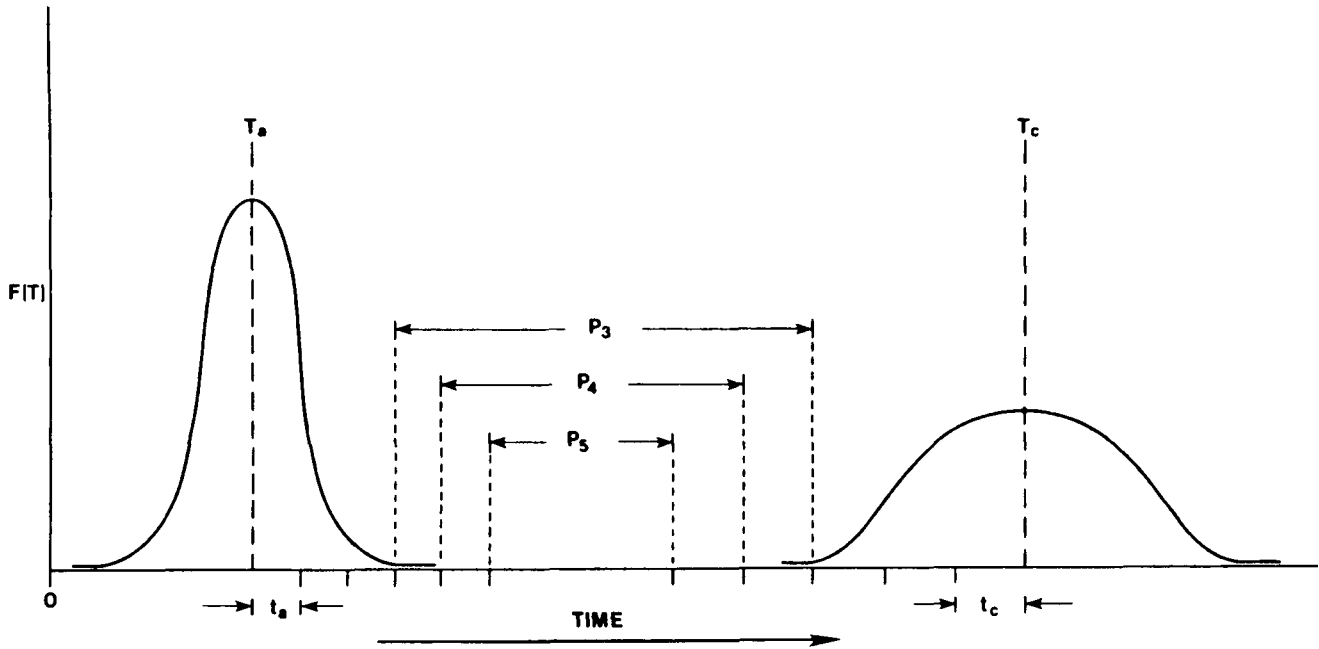

Figure 2. Evaporation Rate Distribution

$$T = [Tc - P(tc)] - [Ta + P(ta)]$$

Where:

- T = Detection Interval
- Ta = Avgas Distribution Mean
- Tc = Contaminated Avgas Distribution Mean
- ta = Avgas Standard Deviation
- tc = Contaminated Avgas Standard Deviation
- P = Desired Probability (number of standard deviations)

Detection intervals in Appendix A (A-1) were calculated by use of this equation and reflect the effects of varying sample size and contamination levels. Generally, the smaller sample sizes and lower contamination levels furnished shorter detection intervals. In fact, some of the samples evaporated so rapidly that negative numbers were generated indicating no available detection time. The length of time required to complete the entire test has been included (in parenthesis) since it is a prime consideration in selection of a suitable detection interval. If the detection interval is subtracted from the total test length, the result is the start time of the detection interval. Use of this data to design an evaporation test is predicated on the knowledge of two requirements: (1)desired sensitivity and (2)total test time. For example, if the user requires positive identification of all contamination in excess of 4% and a test length not to exceed five minutes in duration he is restricted to a sample size of either one or two drops. Any contamination of avgas in greater concentration than that selected from the data in Appendix A (A1-A2) will provide an indication of that contamination during the selected detection interval.

GAS CHROMATOGRAPHY TEST

Gas chromatography is an analyti-

cal technique that separates a compound into its basic components by preferential adsorption to a coated surface. Gas chromatographs are used to analyze a wide variety of compounds and many are designed primarily for laboratory use. Consequently, they are quite complex and costly. However, these instruments are easily redesigned for specific usage, producing a much simplified and less costly design. A typical example of a specific use gas chromatograph is an instrument utilized by arson investigators to identify accelerants used in fires of suspicious nature. Such an instrument, specifically designed as a misfueling detection device is recommended for use by the FBO to aid him in maintaining good quality control over his own refueling operations and to verify the pilot's Evaporation Test in the event contamination is suspected.

The basic components of a gas chromatograph include an oven, a column, a thermal conductivity detector, a signal conditioner, and an output recorder. The oven temperature may be manually or automatically varied, or it may be locked in isothermally which is adequate for misfueling detection. A gas chromatography column, a stainless steel tube (3.048m. by 0.3175m.), packed with specially coated porous particles (10% SP-2340 on 80/100 Chromosorb), is contained within the oven. The packing absorbs a limited range of

hydrocarbon compounds including those of avgas and jet fuel.

Helium, the carrier gas, flows constantly through the column to the detector and after sufficient warm-up time the detector is automatically zero-calibrated. Then a carefully measured fuel sample is injected into the heated input port where it is immediately vaporized. The helium gas transports the vaporized sample through the column where its hydrocarbon components are adsorbed and desorbed at different rates. The lighter, more volatile components are desorbed first and consequently reach the detector before the heavier components. As each of the components passes through the detector it produces an electrical signal proportional to the amount of each component present in each sample. The signal is conditioned to drive a chart recorder that produces a pattern of peaks (chromatogram) each of which identifies a component of the sample. If test conditions such as sample size, oven temperature, and helium flow are held constant chromatogram repeatability is excellent. Thus it is a simple matter to compare an unknown sample with a pure avgas sample to ascertain if the jet fuel components are present.

As stated above, the output from a gas chromatograph is a pattern of peaks known as a chromatogram which is capable of representing each basic component of a complex hydrocarbon compound. Such a chromatogram is found in Appendix IV of Attachment B (D-52). It will be noted that the basic avgas components appear as a large flat-top peak. The chromatogram has been highly amplified to allow the small peaks that follow to be identified thus causing the flat-top or overamplification of the

avgas component. The small following peaks indicate the presence of some of the basic components of jet fuel since even pure avgas contains them in minute quantities. The chromatogram obtained from one percent contamination demonstrates the same avgas peak but the jet fuel peaks are increased in amplitude, clearly identifying the increased contamination level. The size of the peaks is directly proportional to the contamination level and the time required to exit the column and produce a signal at the detector does not vary as long as all conditions are held constant. Thus, the peaks are easily identified as jet fuel components.

Chromatograms of known contaminated fuels are in effect "signatures" with which the signature of an unknown sample may be compared to determine the extent of jet fuel contamination. A gas chromatograph is capable of accurately detecting levels of jet fuel in avgas as low as 1%. Basic operation of the modified instrument is simple and results are highly repeatable. Overall; the reliability, brevity, sensitivity, and operational facility of the Gas Chromatograph Test combine to make it a feasible method of maintaining fuel integrity for the FBO's operations. The method is also a very efficient back-up to confirm the Evaporation Test in the event the pilot of a recently refueled aircraft suspects contamination.

GOW-MAC Instruments Company under contract to NASA, was assigned the task of modifying an existing gas chromatograph to verify the conclusions of this investigation. The modified instrument produced excellent results, verifying the capability of identifying contamination levels of as low as one

percent. It was also equipped with a small microcomputer that performed an analysis of the signal from the output and provided a simplified user oriented "go/no go" LED display. The complete report may be found in Attachment B(D-1).

are to be utilized effectively by the aviation community. Since there are no regulations on the use of such devices it is incumbent on the industry to research the marketing of these products to maximize their use in the interest of aviation safety.

CONCLUDING REMARKS

The detection methods described in this report have been researched and verified. This is the extent of the requirements of the Aircraft Misfueling Detection Project and this report represents the final documentation. However, in the interest of aviation safety, an additional observation must be reported.

In the course of this investigation many FBO's, pilots, and aircraft owners were interviewed, resulting in a genuine concern by most for fear of misfueling or being misfueled. However, in some cases, we encountered a cavalier approach to misfueling that leads to dangerous complacency. This was exemplified by some FBO's who were not interested in purchasing detection equipment because they "had never experienced a situation where any of their personnel misfueled an aircraft with jet fuel." Likewise, the question arose quite often as to whether pilots would take the time to use the Evaporation Test. Such attitudes are obviously dangerous in the aviation community where pilots and FBO's are responsible for the personal safety of others. The two tests described in this report have been proven to accomplish the detection of jet fuel contamination of avgas. They are, however, dependent on the attitude of the user. Commercialization of these products must be implemented by the aviation industry if they

APPENDIX A

EVAPORATION TEST

DATA SUMMARY

1 DROP SAMPLE SIZE:

CONTAMINATION LEVEL	<u>SENSITIVITY</u>				
	1X	2X	3X	4X	5X
1%	* 0.14 **(1.01)	0.01 (0.92)	-0.11 (0.84)	-0.24 (0.75)	-0.36 (0.67)
2%	1.14 (2.01)	0.77 (1.68)	0.40 (1.34)	0.02 (1.01)	-0.35 (0.68)
3%	1.88 (2.75)	1.47 (2.38)	1.06 (2.01)	0.64 (1.63)	0.23 (1.26)
4%	3.67 (4.54)	3.24 (4.15)	2.81 (3.76)	2.38 (3.36)	1.94 (2.97)
5%	4.83 (5.70)	4.04 (4.95)	3.26 (4.21)	2.47 (3.46)	1.68 (2.71)

2 DROP SAMPLE SIZE:

1%	0.32 (1.43)	0.12 (1.29)	-0.09 (1.14)	-0.29 (0.99)	-0.50 (0.85)
2%	3.02 (4.13)	2.24 (3.41)	1.46 (2.69)	0.68 (1.97)	-0.09 (1.25)
3%	3.76 (4.87)	3.10 (4.27)	2.44 (3.67)	1.78 (3.07)	1.12 (2.47)
4%	5.71 (6.82)	5.04 (6.21)	4.37 (5.59)	3.69 (4.98)	3.02 (4.37)
5%	7.89 (9.00)	7.03 (8.20)	6.17 (7.40)	5.32 (6.60)	4.46 (5.80)

* DETECTION INTERVAL LENGTH (MINUTES)

** MAXIMUM TEST LENGTH (MINUTES)

X=STANDARD DEVIATION
(NEGATIVE VALUES INDICATE NO DETECTION TIME AVAILABLE)

3 DROP SAMPLE SIZE:

1%	0.60 (1.93)	0.08 (1.48)	-0.44 (1.03)	-0.96 (0.58)	-1.48 (0.13)
2%	4.00 (5.32)	3.33 (4.73)	2.67 (4.14)	2.00 (3.54)	1.34 (2.95)
3%	6.43 (7.75)	5.81 (7.20)	5.18 (6.65)	4.56 (6.10)	3.94 (5.55)
4%	8.88 (10.21)	7.65 (9.04)	6.41 (7.88)	5.18 (6.72)	3.94 (5.55)
5%	10.44 (11.76)	9.07 (10.47)	7.70 (9.17)	6.33 (7.88)	4.97 (6.58)

4 DROP SAMPLE SIZE:

1%	1.37 (3.01)	0.55 (2.29)	-0.27 (1.57)	-1.08 (0.85)	-1.90 (0.14)
2%	4.49 (6.13)	3.81 (5.55)	3.14 (4.97)	2.46 (4.40)	1.78 (3.82)
3%	8.32 (9.96)	7.37 (9.11)	6.41 (8.25)	5.45 (7.39)	4.50 (6.53)
4%	15.32 (16.96)	13.95 (15.69)	12.59 (14.43)	11.22 (13.16)	9.86 (11.89)
5%	17.89 (19.53)	16.61 (18.35)	15.33 (17.17)	14.05 (15.99)	12.77 (14.81)

5 DROP SAMPLE SIZE:

1%	2.30 (4.19)	1.47 (3.44)	0.64 (2.69)	-0.19 (1.95)	-1.02 (1.20)
2%	5.23 (7.12)	4.57 (6.54)	3.90 (5.95)	3.23 (5.37)	2.57 (4.78)
3%	10.45 (12.34)	9.35 (11.32)	8.25 (10.30)	7.15 (9.29)	6.06 (8.27)
4%	16.47 (18.36)	15.41 (17.38)	14.35 (16.40)	13.29 (15.42)	12.23 (14.44)
5%	25.16 (27.06)	23.94 (25.92)	22.72 (24.77)	21.50 (23.63)	20.28 (22.49)

APPENDIX B

References

1. AVCO Lycoming, AVCO Detonation Analyzers-Description, 1980 Williamsport Division, Williamsport, Pennsylvania.
2. AVCO Lycoming, AVCO Lycoming Requirements to Conduct an In-Flight Detonation Survey, 1980, Williamsport Division, Williamsport , Pennsylvania.
3. National Institute for Petroleum and Energy Research, Inc., Aviation Turbine Fuels, 1984, Bartlesville, Oklahoma.
4. National Transportation Safety Board, Briefs of Accidents, U.S. General Aviation, Washington, D.C. (Computer Generated on Demand)
5. AOPA Air Safety Foundation, 1981, Detecting Jet Fuel Contamination of Avgas, Safety Bulletin No. 1, Frederick, Maryland.
6. Society of Automotive Engineers, Inc., Handbook of Aviation Fuel Properties, 1983, Warrendale, Pennsylvania.
7. Obert, Edward F., 1910-, Internal Combustion Engines, 1968, Scranton International Textbook Co.
8. National Transportation Safety Board, Accident File Contents, Factual Report, 1978 IAD 78-F-A056, "Aviation Accident/Incident", Washington, D.C.
9. National Transportation Safety Board, Accident File Contents, Factual Report, 1984, MKC 84-M-A060, "Aviation Accident/Incident", Washington, D.C.
10. Banks, Herbert W. R., National Transportation Safety Board Initial Briefing to the General Aviation Manufacturer's Association, "Improper Fuel Grades.", 1982, National Transportation Safety Board, Field Investigation Division, Washington, D.C.

APPENDIX C

DEVELOPMENT OF A TEST KIT
TO
DETECT JET FUEL CONTAMINATION OF AVGAS

RUSSELL S. LAWTON
VICE PRESIDENT, OPERATIONS
AOPA AIR SAFETY FOUNDATION
421 AVIATION WAY
FREDERICK, MARYLAND

BACKGROUND

A test procedure to identify aviation fuel contaminated with jet fuel was developed and tested under the Aircraft Misfueling Detection Project. Data was collected to quality operational tests that may be used by pilots to detect contaminated aviation gasoline (avgas) prior to take-off. Repeated use of a test kit by pilots is highly dependent on the utility and attractiveness of the final configuration for the kit.

The AOPA Air Safety Foundation was asked by NASA/Goddard Space Flight Center/Wallops Flight Facility to design and test the final configuration of this kit among pilots, aircraft owners and fixed-base operators (FBO's). The Air Safety Foundation was well suited for this purpose since it conducts training programs attended by more

than 10,000 pilots and aircraft owners annually.

With respect to the design and evaluation of the test kit, the Air Safety Foundation was asked to:

- (1) Review available accident reports to determine the operational modes that could affect the design of the test kit.
- (2) Conduct a survey of pilots, aircraft owners and FBO's to obtain information pertinent to test kit design. In addition, FBO's were also to be surveyed on the feasibility and practicality of using a gas chromatograph detection unit.
- (3) Describe the design of a prototype contamination detection kit.
- (4) Make recommendations for additional testing of the

design parameters if necessary.

- (5) Provide design drawings for an operational test kit and instructions for its use.

METHODOLOGY

Accident/Incident Review

Aircraft misfueling accidents and incidents from 1964 to 1983 were reviewed to develop a profile of the typical misfueling situation. These accidents are classified as "Fuel Grade - Improper," and include those accidents/incidents where the incorrect type of fuel was used instead of the fuel for which the engine was originally certified, e.g., auto fuel, jet fuel, wrong grade, etc. The following data bases were queried in order to retrieve this information:

- *Federal Aviation Administration (FAA) - Accident/Incident Data System (AIDS)
- *International Civil Aviation Organization (ICAO) - Accident Data Reports (ADREPS)
- *National Aeronautics and Space Administration (NASA) - Aviation Safety Reporting System (ASRS)
- *National Transportation Safety Board (NTSB) - Briefs of Accidents for U.S. General Aviation

The accident/incident reports from the five data bases were compared in order to eliminate duplicate reports. Seventy-seven reports were found under the classification "Fuel Grade - Improper." There were no reported accidents/incidents where single engine aircraft certified to use aviation gasoline were misfueled with jet fuel. The single engine aircraft accidents reviewed were caused due to water contamination and/or the improper use of auto fuel.

The aircraft most often misfueled with jet fuel were twin engine aircraft belonging to a manufacturer's product line utilizing both piston and turbine engines, e.g., Aero Commander and Cessna 400 series. Other twin engine aircraft misfueled with jet fuel were the result of improperly trained flight line service personnel who assumed that the aircraft should be serviced with jet fuel instead of avgas.

The most reliable method of detecting jet fuel contamination of avgas when utilizing the evaporation test is by obtaining a fuel sample from the aircraft fuel tank filler port where the jet fuel may be introduced. The fuel tank filler ports on many of the aircraft involved in misfueling accidents are difficult to access by pilots during normal preflight inspection without the use of a ladder. It was recommended that NASA conduct a test to determine how quickly the fuel in an aircraft tank could be contaminated with jet fuel when it was introduced at the filler neck and combined with avgas.

A test was conducted at the Wallops Flight Facility to determine the time required for a two percent by volume sample of jet fuel to completely mix with a container of avgas. Although the two fuels mixed almost instantly within the container, more time would be required for the contaminated fuel to settle into an aircraft fuel strainer and sump system.

Many aircraft utilize multiple fuel tanks and intricate fuel line systems. Therefore, the evaporation test method is most reliable when a fuel sample is obtained from the fuel tank filler port.

Detection Kit Development

Demonstrations of the evaporation test were conducted by Air Safety Foundation staff at various training programs throughout the United States. Approximately 600 pilots and aircraft owners observed the test utilizing laboratory filter paper and avgas samples composed of two percent and five percent levels of jet fuel contamination. Everyone observing the test was impressed with its simplicity and ease of use.

Those in attendance were asked if they would purchase a kit if the price were under ten dollars. Many stated that they would not purchase the kit if the cost was more than ten dollars.

Considering the feedback received from these people, it is determined that the test kit should be constructed from readily available materials so that it can be produced and sold commercially for less than ten dollars. Other factors that need to be considered in the design of the test kit are:

- * Durability and ease of portability.
- * Ability to withstand temperature extremes.
- * A sufficient quantity of test paper to conduct repeated tests.
- * A method of shielding the test paper from wind since the rate of evaporation is critical in the detection of jet fuel.

The project team believed that most pilots and aircraft owners would not go to a location where laboratory filter paper is sold in order to obtain replacement paper for sampling. Other paper types were evaluated which might be more readily available. A good

substitute was found by using plain white calculator paper which was not treated with any type of pressure sensitive material. This type of paper is both readily available and inexpensive, thereby, being more conducive to frequent use and replacement. Plain white calculator paper made from 12-lb. lightweight bond was evaluated by the NASA Goddard Space Flight Center/Wallops Flight Facility and determined to be of consistent quality for repeated evaporation tests.

A box capable of holding a 2-1/4" wide roll of calculator paper was fabricated from 1/8" clear acrylic (Figure 1). The paper roll is fed through a tension device which assures a flat area on the paper for conducting the test. A 1-1/2" diameter opening on the tension device is used to place the fuel sample on the paper. The tension device is set 3/4" down from the top of the box for wind protection. A feed slot on the box side allows the used paper to be removed, torn off, and replaced by a clean sample. Once the paper supply is depleted, it can be replaced by turning the box upside down and sliding out the used paper roll. A holder for the eye dropper and attachment line was mounted on the box lid.

Once the prototype test kit was fabricated and refined, demonstrations were conducted at Air Safety Foundation training programs. The pilots and aircraft owners in attendance observed a demonstration of the test kits and were given an opportunity to conduct the test individually. Comments concerning the simplicity and ease of using the test kit were extremely positive. Most who participated and/or observed the demonstration stated they would purchase the kit if it sold in the

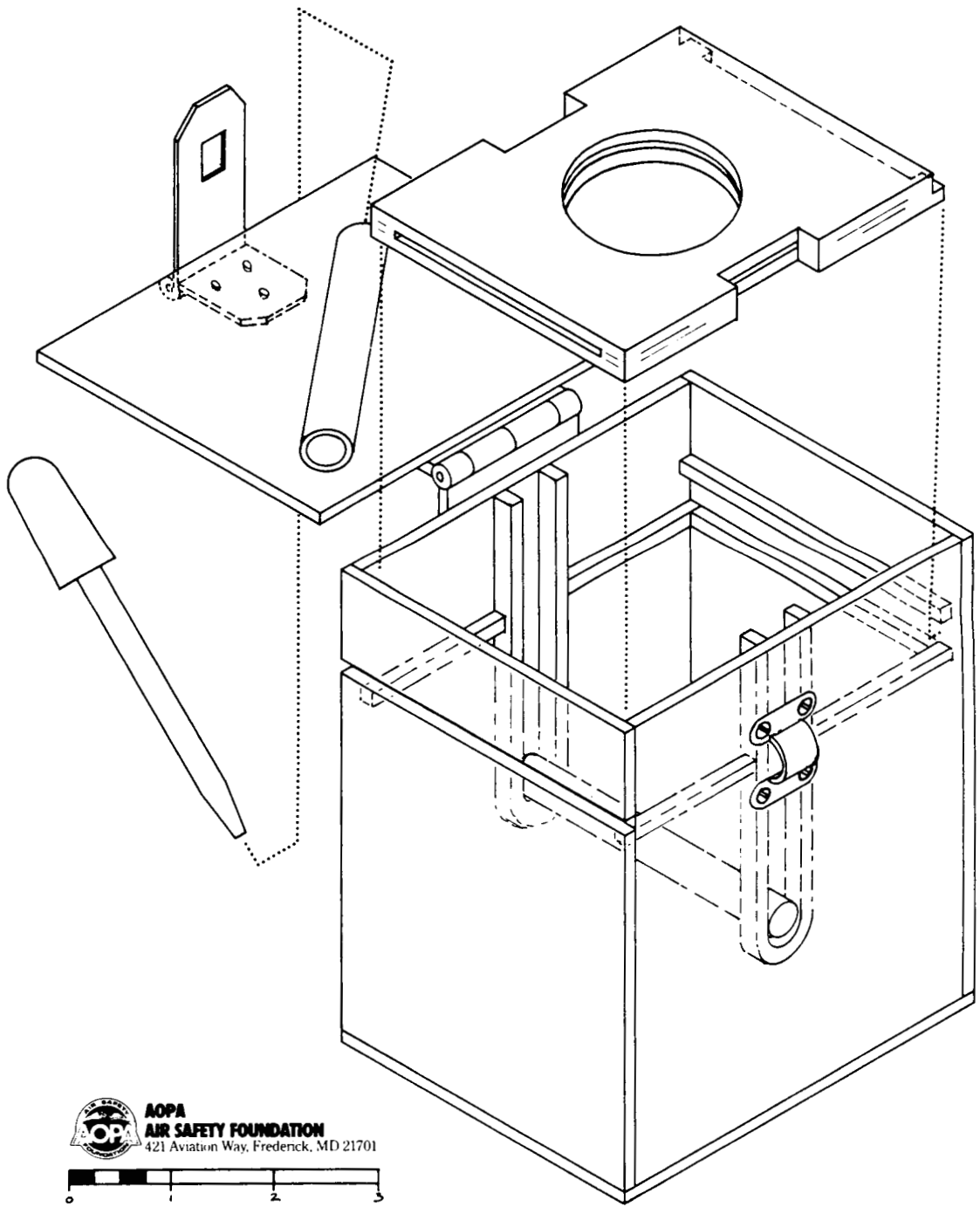

Figure 1. Detection Kit Design

\$10-\$15 price range.

Demonstrations of the prototype test kit were also conducted at ten fixed base operators (FBO's) in the eastern U.S. The FBO staffs observing the demonstrations were also impressed that jet fuel contamination could be detected with this simple method. These same FBO's were also queried concerning the possibility of using a gas chromatograph as a positive test once jet fuel contamination was suspected. Although the FBO personnel were generally in favor of using a more positive indication of jet fuel contamination, they balked at purchasing a \$1500 - \$2000 instrument which could only be used for this one test procedure.

These same FBO's expressed reticence at purchasing this equipment since they had never experienced a situation where any of their personnel misfueled an aircraft with jet fuel. The FBO's expressed interest in viewing a demonstration of the gas chromatograph, however a demonstration unit was not available when the survey was conducted.

Design Parameters

The prototype test kit developed by the Air Safety Foundation which was described previously and detailed in Figure 1 appears to meet the objectives in the Statement of Work. The test kit is small enough to be carried in the typical pilot's flight case. The essential kit components (paper roll and eye dropper) are easy to replace and inexpensive. Most importantly, the test kit can repeatedly detect a jet fuel contamination level of two percent by volume.

The test kit should be constructed from acrylic material of at least 1/8" thickness to withstand normal wear and tear as well as the range of temperatures encountered in aviation operations. Prototype test kits were constructed of 1/16" plastics, but these were not of adequate durability.

The white calculator paper worked as well as the laboratory filter paper in detecting jet fuel contamination of avgas. A roll of calculator paper costs approximately one dollar and is normally 200 feet long. Anyone conducting the test need not be concerned with the expense of the paper, and hopefully, will conduct as many tests as necessary to be confident that no jet fuel contamination exists.

The eye dropper used to obtain the fuel samples is stored on the lid of the test kit. A nylon line three feet in length attaches the eye dropper to the test kit. The nylon line allows the individual to retrieve the eye dropper in the event it is dropped into the fuel tank while obtaining a fuel sample for the test.

Recommendations

The Air Safety Foundation does not believe that any further testing and/or development of the prototype jet fuel contamination detection kit is required. The evaporation test method of detecting jet fuel contamination of avgas has been thoroughly tested and documented by NASA. The prototype test kit developed by the Air Safety Foundation with the assistance of the NASA Goddard Space Flight Center/Wallops Flight Facility meets the objectives for detecting jet fuel contamination on a repeated basis.

Instructions for Use of Test Kit

The recommended construction for the test kit is detailed in Figure 2. The following procedure should be followed when using the kit during preflight inspection:

- (1) Remove the eye dropper from holder and unwind nylon line to full length (approximately three feet).
- (2) Using the eye dropper, obtain a fuel sample from the fuel tank opening.
- (3) Place two drops of the fuel on the flat surface of the paper contained in the 1-1/2" circular opening in the test kit. A spot about the size of a quarter should be formed.
- (4) Observe the outside of the spot as it dries. Pure avgas will evaporate from the outside moving inward, leaving the outer margin indistinct. After approximately two minutes, pure avgas will disappear completely, leaving no signs of a spot, having completely disappeared.
- (5) Jet fuel contaminated avgas will show a distinct perimeter on the paper, and fade only after several minutes. The jet fuel will often leave a filmy substance on the paper which is easily observed when held up to a light source.
- (6) Remove the used paper sample from the side of the box and tear off. If contamination is suspected, repeat the procedure using a sample of the suspect fuel. Remove the test paper and save. Obtain a sample of pure

avgas and place on clean test paper. Compare the evaporation rates for the two samples. If the pure avgas sample evaporates more quickly, the suspect sample may be contaminated.

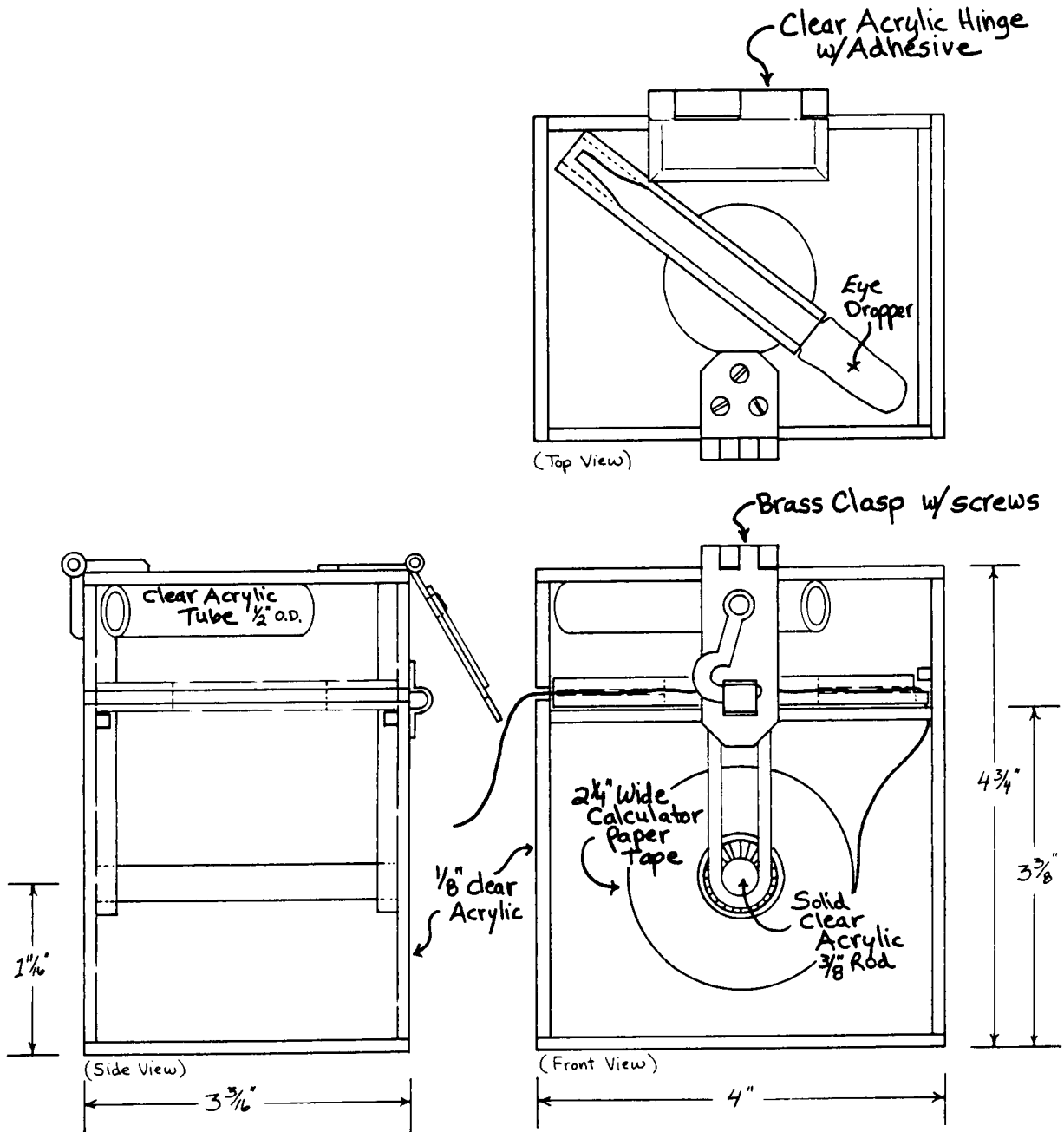
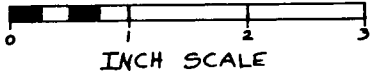

Figure 2. Details of Design Specifications

REFERENCES

Accident Data Reports, International Civil Aviation Organization, Montreal, Quebec, Canada.

Briefs of Accidents, U.S. General Aviation, National Transportation Safety Board, Washington, D.C.

"Contamination of Aviation Gasoline with Heavier Fuels." American Society of Testing and Materials.

"Detecting Jet Fuel Contamination of Avgas," Safety Bulletin #1. AOPA Air Safety Foundation, Frederick, Maryland.

"General Aviation Accidents Involving Misfueling as a Cause or Factor." Federal Aviation Administration, Safety Analysis Division, Washington, D.C.

"Substitution of Jet Fuel for Avgas," Search Request No. 808. Aviation Safety Reporting System, National Aeronautics and Space Administration, Ames Research Center, Moffett Field, California.

APPENDIX D

MODIFICATION TO A GAS CHROMATOGRAPH

TO DETECT JET FUEL CONTAMINATION OF AVIATION GASOLINE

(STATEMENT OF WORK # 824-477381620)

FOR: NASA, GODDARD SPACE FLIGHT CENTER
WALLOPS FLIGHT FACILITY
WALLOPS ISLAND, VIRGINIA

Prepared By:
GOW-MAC Instrument Co.
X.F. Gonzalez, Consultant

ABSTRACT

A thermal conductivity gas chromatograph in conjunction with a Signal Processing Module capable of detecting one percent jet fuel contamination peak has been successfully tested. The Signal Processor accepts the gas chromatograph signal and utilizes an algorithm implemented with a single chip microcomputer to perform the analysis of the aviation fuel. An LED display and a single START/STOP switch provides simplified user oriented "go/no go" analysis. The use of a microcomputer allows for adjustment of retention time zones and peak value threshold. The software has been written to allow upgrading to detect other fuel contamination.

INTRODUCTION

The detection of jet fuel contamination of aviation gasoline has been successfully demonstrated in the chemistry laboratory at GSFC/WFF. Tests conducted under the Aircraft Misfueling Detection Project have detected concentrations as low as 1 percent by use of a laboratory type gas chromatograph. However the interpretation of the resulting output limits the flightline use of the instrument.

This project adapts the chromatograph output for use by the fixed base operator (airport manager). The instrument modification designed is a Signal Processing Module that provides a visual indication of the fuel sample analysis. The instrument system has been successfully tested at the GOW-MAC Instrument Company over ranges of 50% to 1% jet fuel contaminations as well as 0% jet fuel contamination.

OVERALL SYSTEM CONFIGURATION

The system consists of a dual column gas chromatograph (GOW-MAC Model 69-5590), a carrier gas cylinder, and Signal Processor Module. Figure 1 illustrates the basic system. The columns on the gas chromatograph have been selected to separate the aviation fuel and the jet fuel components under specific conditions. The aviation fuel sample to be tested is injected into the injection port where it vaporizes and is carried by the carrier gas. The vaporized sample of aviation fuel and any jet fuel contamination are separated in the column. The separate components are passed through the thermal conductivity detector which senses the relative thermal conductivity of the component gases. An electrical signal, proportional to the thermal conductivity of each component, is generated as it passes through a resistance bridge detector.

The Signal Processor Module is a specially designed unit that utilizes the detectors electrical signal to determine if the aviation fuel peak occurs at the correct time and if there is any jet fuel contamination present.

SIGNAL PROCESSOR MODULE (HARDWARE DESCRIPTION)

A typical chromatograph of 1% contaminate is shown in Figure 2. The main peak due to aviation fuel has a retention time of 1 minute and a peak that exceeds 1 millivolt. The main peak of the jet fuel contamination has a retention time of approximately 2 minutes and a peak in the order of 0.035 millivolts. The system used to detect the contaminate is shown in Figure 3. The system consists of a

single chip microprocessor (Intel 8751), a 12 bit Digital to Analog Converter (DAC), highly specialized analog operational amplifiers and visual display via drivers. A microprocessor was chosen to provide future flexibility to detect other contaminants that may be present in the aviation fuel. Additionally, retention time zones and signal threshold constants can be adjusted by changing constants in Read Only Memory (ROM).

The DAC in conjunction with the microprocessor is configured into a tracking analog to digital converter (ADC). The ADC loop is controlled by a comparator capable of sensing 10 microvolt differences around zero. This sensitive comparator had to be made from a high gain amplifier (OPO6). The output of OPO6 is used to saturate a comparator (LF311). The digital signal out of the LF311 comparator goes into a microprocessor input port and is used to indicate the signal polarity (within 10 microvolts).

The gas chromatograph signal from the bridge circuit is fed into a balanced summing amplifier (OPO7). The balanced DAC output is injected into the amplifier so as to null out the bridge voltage. The output of the comparator indicates to the processor the direction that the DAC must be driven in order to null the detector signal. The microprocessor updates the DAC at a 0.25 millisecond rate in an attempt to null the amplifier. The DAC will easily track the low frequency (10hz bandwidth) gas chromatography signals and high frequency noise will average zero.

The microprocessor controls the eight display LEDs. A group of five LEDs are used to assist the operator in zeroing the bridge. A

push button is used to activate the timing cycle to measure the sample retention time. The push button can also be used to abort the timing cycle. The timing cycle is shown in Figure 4. The RUN LED is used to indicate the status of the timing cycle. When the timing cycle is active the RUN LED is on. When the timing cycle is completed the analysis of the sample is finished and the RUN LED blinks. To reset the timing cycle the push button is pressed and the RUN LED goes off. Two more LEDs indicate a pass or failed condition after the analysis is completed. Refer to the schematic in Appendix I for a more detailed circuit.

SIGNAL PROCESSOR MODULE (SOFTWARE DESCRIPTION)

Refer to Figure 5 for a flow chart description of the software driver. A description of each procedure follows:

1. TIC COUNT:
Is a real time interrupt procedure used to keep track of time. It also passes tokens to the main program to activate procedures in the main program.
2. DAC UPDATE:
Test the "signal polarity" input port. It determines the sense of the detector signal and outputs a 12 bit digital signal to the DAC in opposition to the sensed signal in order to null the detector's bridge signal. An internal count of the DAC value (DAC-COUNTER) is maintained and updated during this procedure.
3. SWITCH:
This routine will sample the START/STOP switch input port. Toggles the

"START" flag used internally to start a run or to abort a run.

4. TIME:

Maintains the internal flags and initializes internal flags.

5. LITE:

This routine maintains the output display. The zero adjustment routines help the operator zero the bridge. When the bridge signal is zero the green LED will be turned on. Two yellow LEDs (one positive and the other negative off zero conditions) indicate a slightly off zero condition. Two red LEDs (one positive and the other negative off zero condition) indicate that the operator must adjust the bridge zero before starting. If either of the two RED LEDs are blinking it indicates that the zero is out of the DAC range and must be zeroed before starting. The RUN LED is:

- A. Off if START flag has not been activated.
- B. On if START flag has been activated.
- C. Blinks if the run is completed.

The Pass and Fail LEDs indicate the result of the analysis at the completion of the run.

6. ZONE:

When the START flag is activated a RUN-COUNTER keeps track of the time. This counter is used to maintain 5 zones used to measure retention time.

- A. ZONE 0 STOPPED
- B. ZONE 1 0 to 30 seconds
- C. ZONE 2 30 to 90 seconds

(avgas fuel peak expected)

D. ZONE 3 90 to 150 seconds
(contamination peak, if any, expected)

E. Zone 4 > 150 seconds
(run completed)

7. ANALYSIS;

The analysis procedure is used to detect:

- A. The aviation fuel peak during the Zone 2 interval.
- B. Any contamination peaks during Zone 3 interval.

The detection of the aviation fuel is done by comparing the DAC-COUNTER (value) during Zone 2. If the DAC-COUNTER exceeds a given constant then the aviation fuel peak has been sensed.

This constant is an absolute value and is chosen very near the maximum DAC value. The detection of the contamination is performed by integrating, during the time Zone 3, the detector signal. If this integral exceeds a predetermined constant (selected at 1% contamination for this unit) then a FAIL-ed condition is flagged.

The flow chart indicates the execution sequence of the described procedures. A more precise documentation is supplied in Appendix II which provides the PLM source and the subsequent assembler code that has been generated.

SIGNAL PROCESSOR OPERATION

An operator would proceed as follows:

1. Set up the G.C. to the given operating conditions (see Appendix III) and wait 30 minutes for the G.C. temperature to stabilize.
2. Zero the detector by ob-

- serving the zeroing LEDs. Adjust the zero until in the green or either yellow LED is on.
3. Check the RUN, PASS, and FAIL LEDs. These LEDs should be off. If not, depress the START/STOP switch to abort the run and prepare for a new start.
 4. Obtain a sample of the fuel mixture to be tested and inject it into the injection port.
 5. Immediately press the START/STOP button to start the analysis. The yellow RUN LED will come on.
 6. At the end of the run (150 seconds) the yellow LED will blink indicating the end of the run. The PASS or the FAIL LED will be activated as the result of the analysis.

TESTING

Testing of the Signal Processing Module was conducted over several days. Aviation fuel samples with jet fuel contamination from 1% to 50% were tested successfully. Also tested successfully were the pure samples of aviation fuel. Recorder output of the tests are provided in Appendix IV. From these tests it appears that a GOW-MAC Model 550 gas chromatograph in conjunction with the modification is capable of detecting low level contaminations.

FIGURE 1A. DETECTOR ELECTRICAL OUTPUT

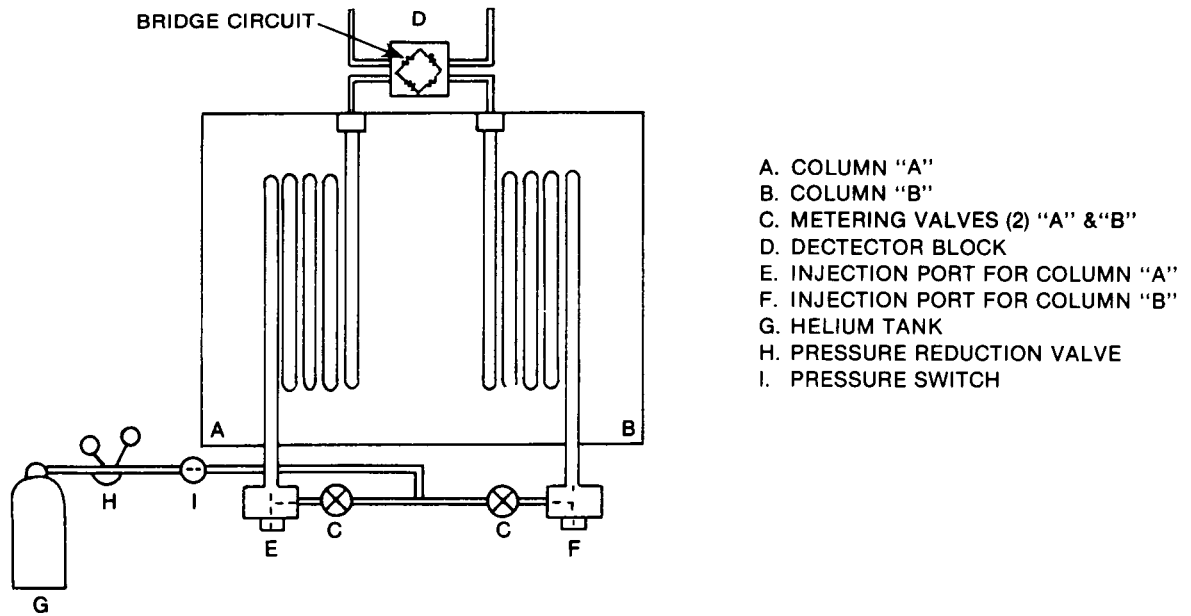
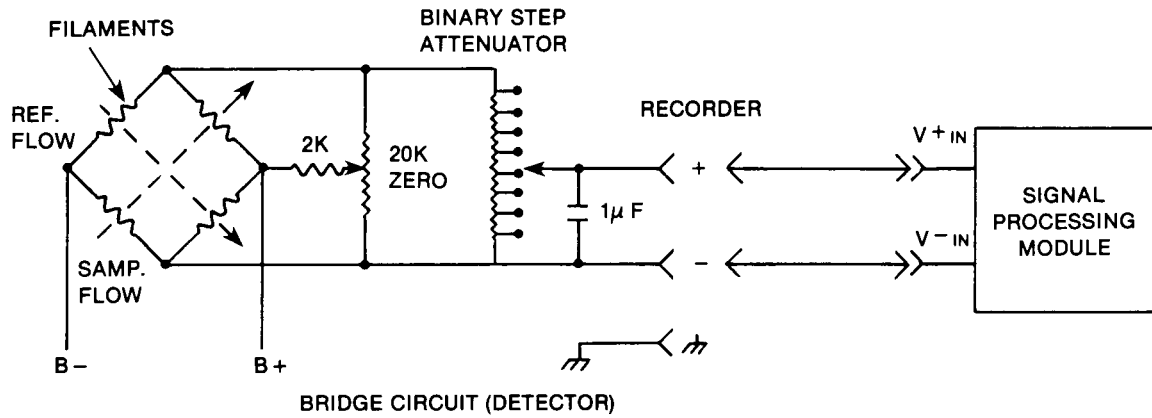

FIGURE 1B. G.C. SYSTEM

Figure 1. Basic System

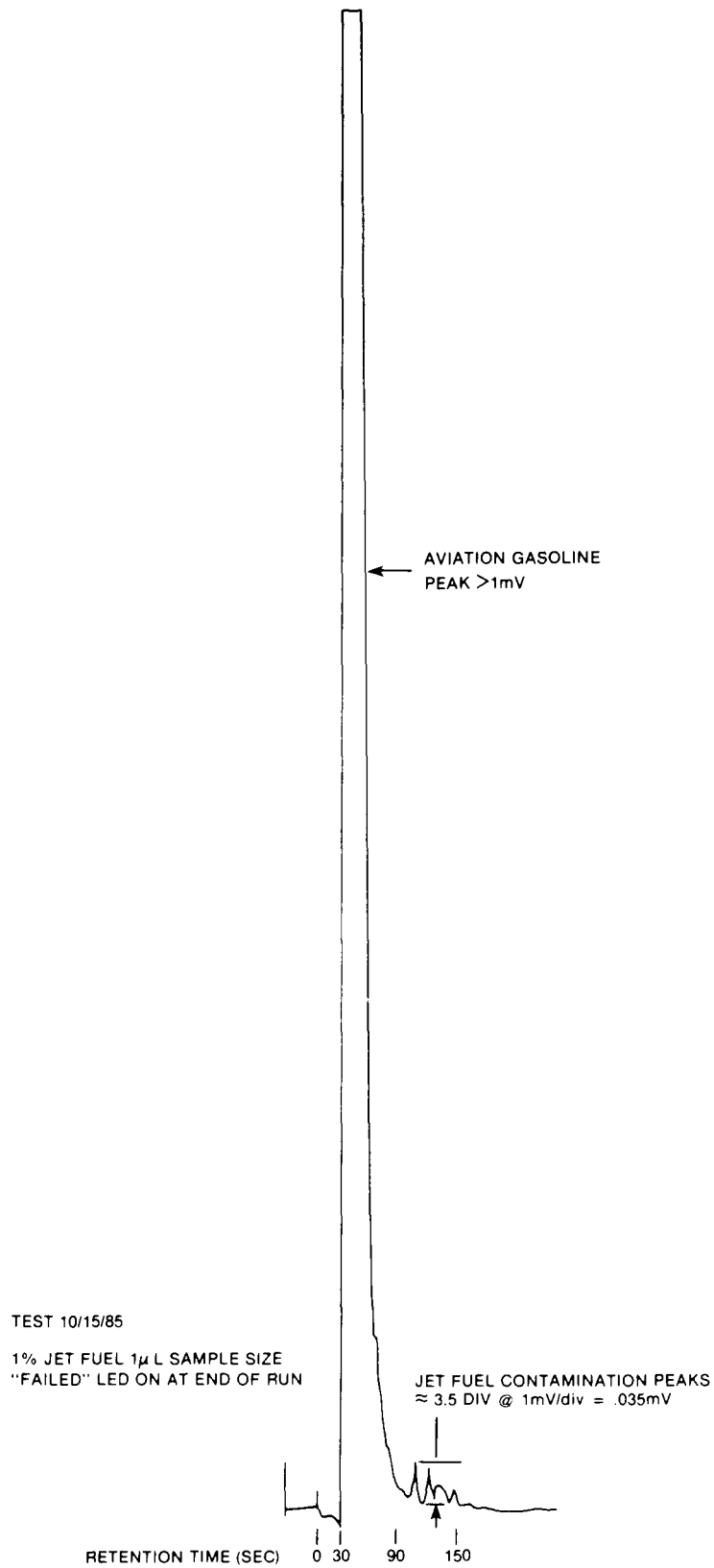

Figure 2. 1% Jet Fuel Contamination of Aviation Gasoline Chromatography Profile

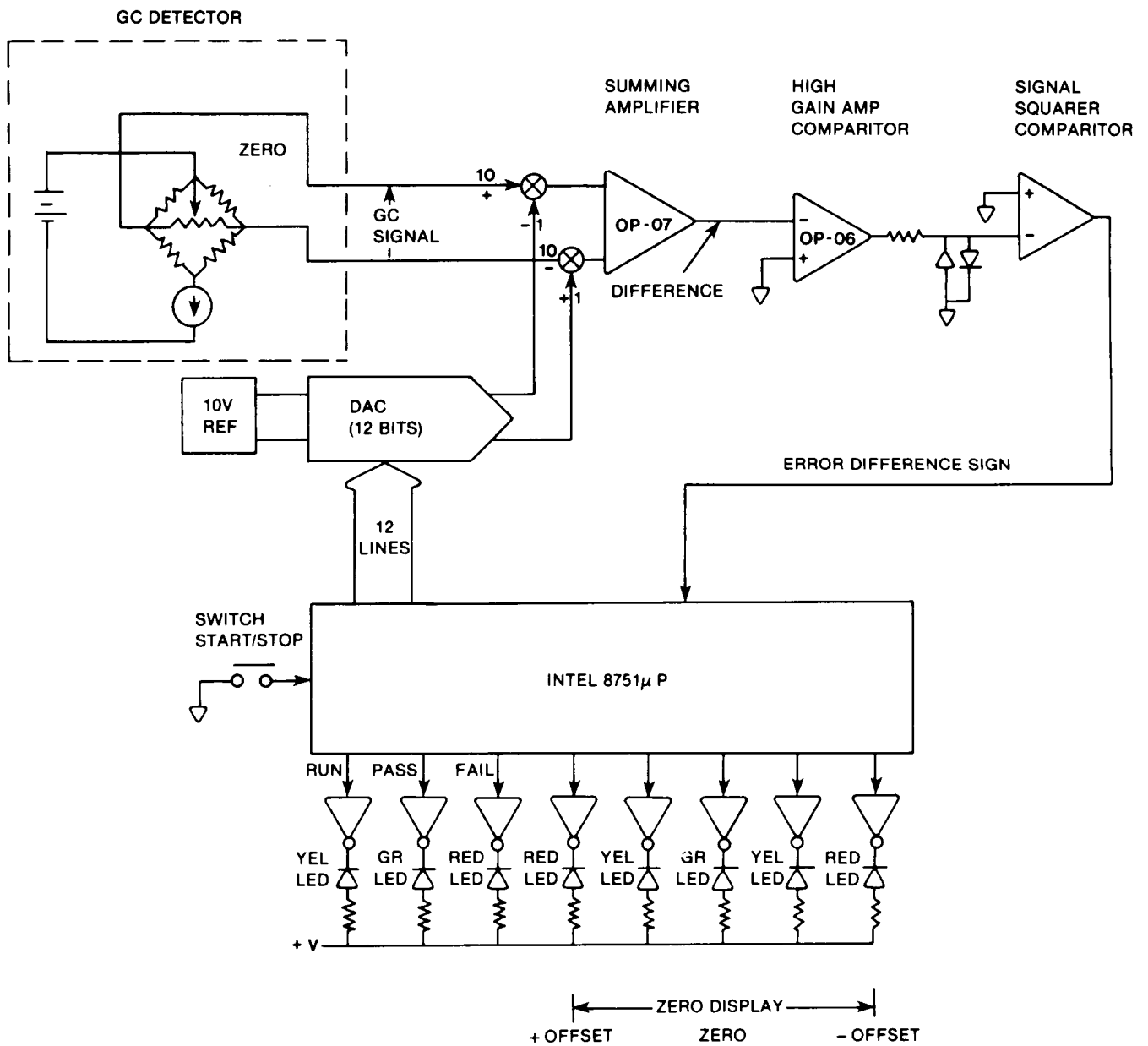

Figure 3. Aviation Fuel Contamination Signal Processor

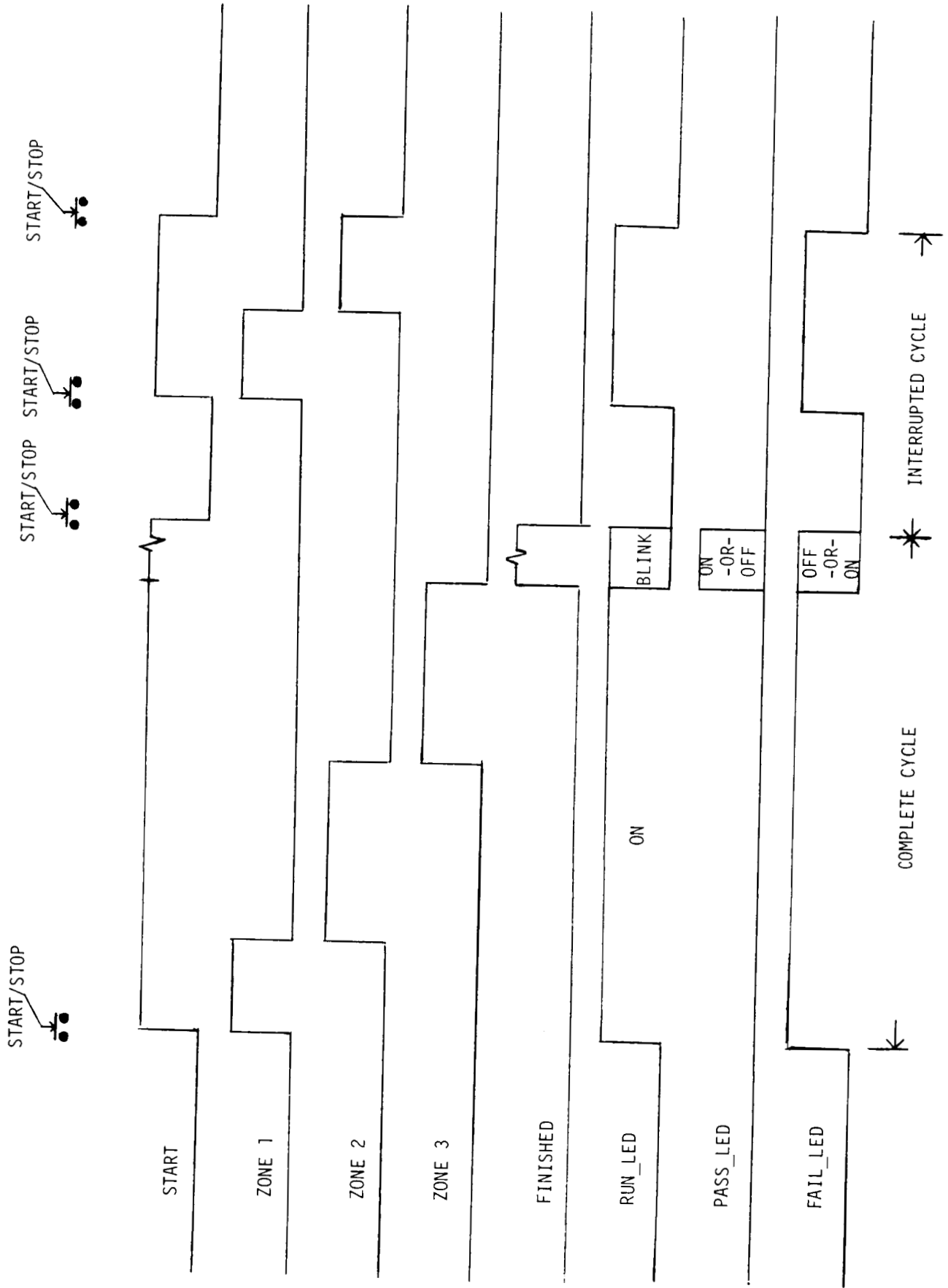

Figure 4. Timing Cycle

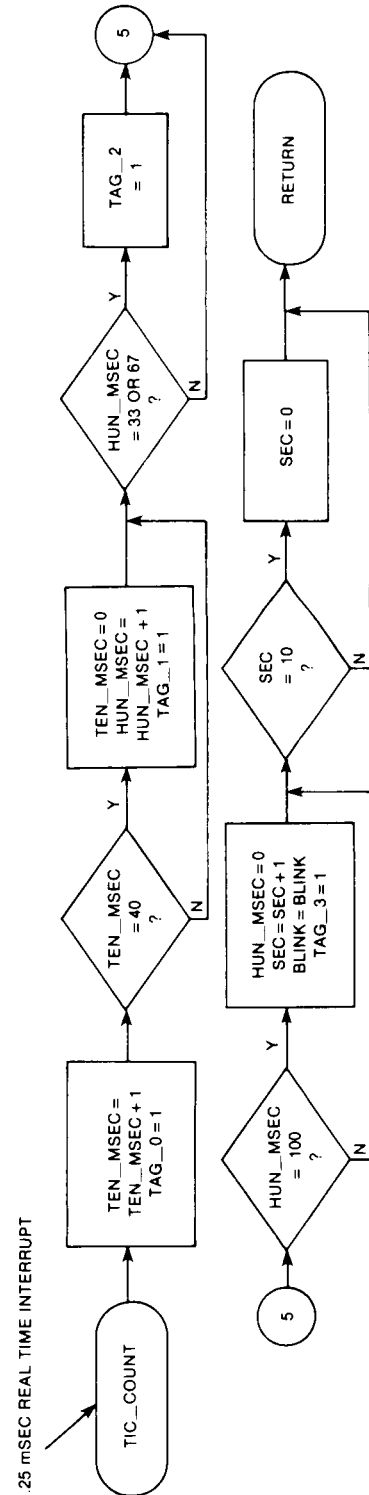
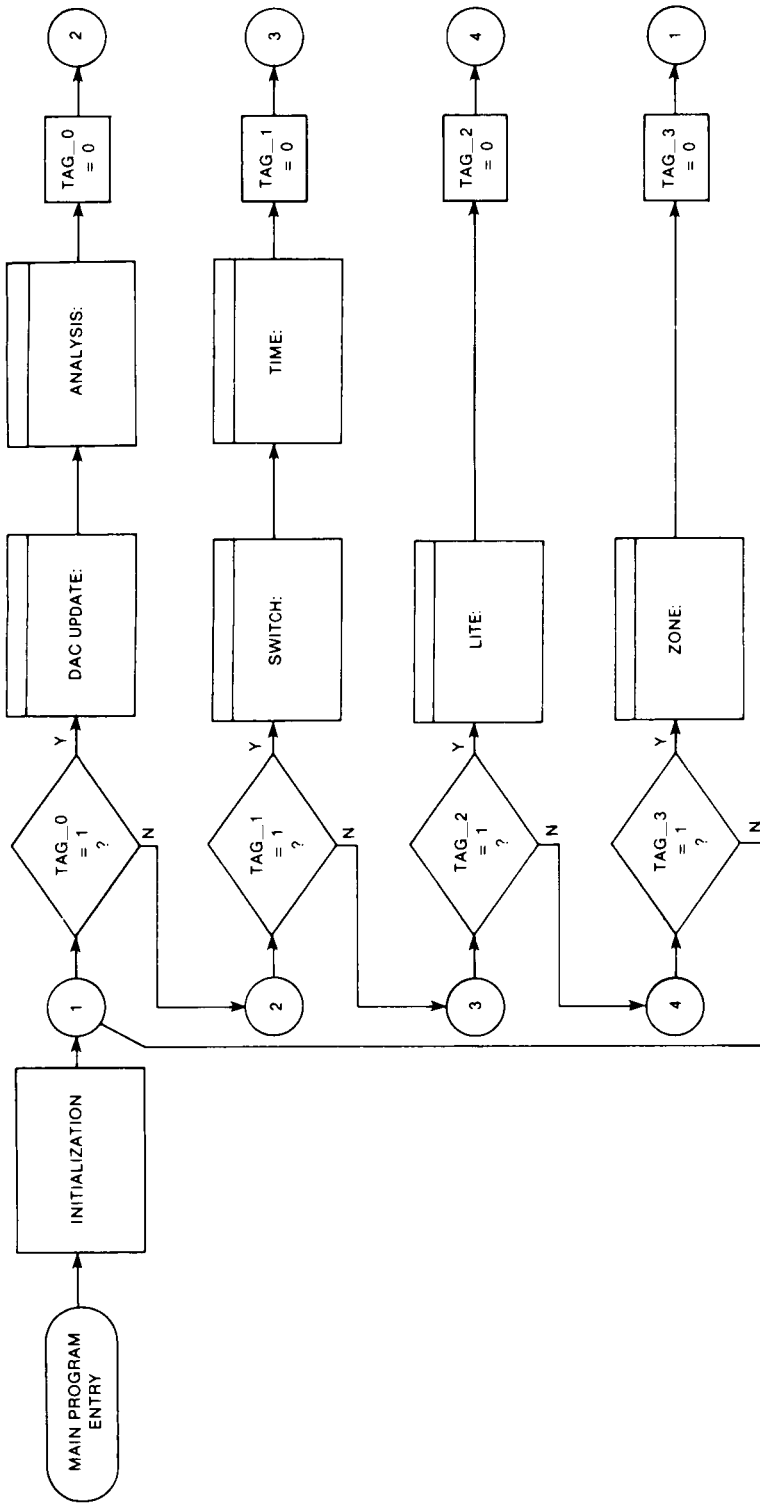

Figure 5. Program Flow

APPENDIX I

SIGNAL PROCESSOR SCHEMATIC

APPENDIX II

SOFTWARE:

1. SOURCE PROGRAM & ASSEMBLY LEVEL PROGRAM
2. RELOCATOR & LINKER

ISIS-II PL/M-51 V1.1

COMPILER INVOKED BY: PLM51 NASOO.PLM DATE(9/15/85) DB OJ SB CO XREF

```

/*****
/*
/*      NASA AVIATION FUEL CONTAMINATION SOFTWARE      */
/*      BY: X. F. GONZALEZ                          */
*****/

```

```

1  1  NASA00: DO;          /*DECLARATION I/O REGISTERS FOR B051*/
2  1  DECLARE DCL LITERALLY 'DECLARE';
3  1  DCL PORT_0        BYTE AT(80H) REGISTER;
4  1  DCL SP           BYTE AT(81H) REGISTER;
5  1  DCL TCON         BYTE AT(88H) REGISTER;
6  1  DCL TMOD         BYTE AT(89H) REGISTER;
7  1  DCL SCON         BYTE AT(98H) REGISTER;
8  1  DCL IE           BYTE AT(0A8H) REGISTER;
9  1  DCL IP           BYTE AT(0B8H) REGISTER;
10 1  DCL PORT_1_BIT_0  BIT  AT(90H) REGISTER;
11 1  DCL PORT_1_BIT_1  BIT  AT(91H) REGISTER;
12 1  DCL PORT_1_BIT_2  BIT  AT(92H) REGISTER;
13 1  DCL PORT_1_BIT_3  BIT  AT(93H) REGISTER;
14 1  DCL HI_RED_LED    BIT  AT(0A0H)REGISTER; /*P2.0*/
15 1  DCL HI_YEL_LED    BIT  AT(0A1H)REGISTER; /*P2.1*/
16 1  DCL ZERO_GRN_LED  BIT  AT(0A2H)REGISTER; /*P2.2*/
17 1  DCL LO_YEL_LED    BIT  AT(0A3H)REGISTER; /*P2.3*/
18 1  DCL LO_RED_LED    BIT  AT(0A4H)REGISTER; /*P2.4*/
19 1  DCL FAIL_LED      BIT  AT(0A5H)REGISTER; /*P2.5*/
20 1  DCL PASS_LED      BIT  AT(0A6H)REGISTER; /*P2.6*/
21 1  DCL RUN_LED       BIT  AT(0A7H)REGISTER; /*P2.7*/
22 1  DCL EA            BIT  AT(0AFH)REGISTER; /*ENABLE INTERRUPTS*/
23 1  DCL START_STOP_SW BIT  AT(0B3H)REGISTER; /*P3.3*/
24 1  DCL DAC_COMP      BIT  AT(0B4H)REGISTER; /*P3.4*/
25 1  DCL DAC_COUNTER  WORD;
26 1  DCL PEAK_COUNTER WORD;
27 1  DCL RUN_COUNTER  WORD;
28 1  DCL TEMPER_WORD  WORD;
29 1  DCL DAC_MAX_COUNT WORD CONSTANT (0FFFH);
30 1  DCL PEAK_1        WORD CONSTANT (0FFFFH);
31 1  DCL PEAK_2        WORD CONSTANT (0EFFH);
32 1  DCL PEAK_3        WORD CONSTANT (00FFH);
33 1  DCL WINDOW_1      WORD CONSTANT (0700H);
34 1  DCL WINDOW_2      WORD CONSTANT (07F0H);
35 1  DCL WINDOW_3      WORD CONSTANT (080FH);
36 1  DCL WINDOW_4      WORD CONSTANT (08FFH);
37 1  DCL WINDOW_5      WORD CONSTANT (0FFFH);
38 1  DCL TIME_1        WORD CONSTANT (001EH);
39 1  DCL TIME_2        WORD CONSTANT (005AH);
40 1  DCL TIME_3        WORD CONSTANT (0096H);
41 1  DCL TIME_4        WORD CONSTANT (00C8H);

```

```

42 1 DCL TEN_MSEC BYTE;
43 1 DCL HUND_MSEC BYTE;
44 1 DCL SEC BYTE;
45 1 DCL WINDOW BYTE;
46 1 DCL ZONE_I BYTE;

47 1 DCL UP_DNNOT_FLAG BIT;
48 1 DCL TAG_0_INTR3 BIT;
49 1 DCL TAG_1_INTR3 BIT;
50 1 DCL TAG_2_INTR3 BIT;
51 1 DCL TAG_3_INTR3 BIT;
52 1 DCL BLINK BIT;
53 1 DCL START BIT;
54 1 DCL START_N BIT;
55 1 DCL START_P BIT;
56 1 DCL RUN BIT;
57 1 DCL FINISH BIT;
58 1 DCL ZONE_1 BIT;
59 1 DCL ZONE_2 BIT;
60 1 DCL ZONE_3 BIT;
61 1 DCL ZONE_4 BIT;
62 1 DCL FAIL_ZONE_1 BIT;
63 1 DCL PASS_ZONE_2 BIT;
64 1 DCL FAIL_ZONE_3 BIT;

/*STRUCTURE TO OVERLAY BYTE ONTO BITS*/
65 1 DCL TEMPOR_BIT STRUCTURE ((B0,B1,B2,B3,B4,B5,B6,B7) BIT);
66 1 DCL TEMPOR_BIT_OVR BYTE AT ( .TEMPOR_BIT );

$EJECT
67 2 TIC_COUNT: PROCEDURE INTERRUPT 3 USING 0;
/*USE 12 M HZ CLOCK TO OBTAIN .25 M SEC PER INTERRUPT */
68 2 TEN_MSEC=TEN_MSEC +1;
69 2 TAG_0_INTR3=1;
70 2 IF TEN_MSEC = 40 THEN
71 3 DO;
72 3 TEN_MSEC = 0;
73 3 HUND_MSEC = HUND_MSEC + 1;
74 3 TAG_1_INTR3=1;
75 3 IF (HUND_MSEC=33) OR (HUND_MSEC=67) THEN
TAG_2_INTR3=1;
77 3 IF HUND_MSEC =100 THEN
78 4 DO;
79 4 HUND_MSEC = 0;
80 4 SEC = SEC + 1;
81 4 TAG_3_INTR3=1;
82 4 BLINK = NOT BLINK;
83 4 IF SEC = 10 THEN SEC = 0;
85 4 END;
86 3 END;
87 1 END TIC_COUNT;

```

\$EJECT

```
88 2 DAC_UPDATE: PROCEDURE;

89 2     UP_DNNOT_FLAG = DAC_COMP;
90 2     IF UP_DNNOT_FLAG = 1 THEN
91 3     DO;
92 3         IF DAC_COUNTER >= DAC_MAX_COUNT THEN
93 3         DAC_COUNTER = DAC_MAX_COUNT;
94 3         ELSE DAC_COUNTER = DAC_COUNTER + 1;
95 3     END;
96 2     ELSE
97 3     DO;
98 3         IF DAC_COUNTER = 0000H THEN
99 3         DAC_COUNTER = 0000H;
100 3         ELSE DAC_COUNTER = DAC_COUNTER - 1;
100 3     END;

    /*OUTPUT TO DAC*/
101 3     DO;
    /*OUTPUT MS BYTE TO DAC*/
102 3     TEMPOR_WORD = SHL (DAC_COUNTER,4);
103 3     PORT_0 = HIGH ( TEMPOR_WORD );
    /*OUTPUT LS BITS TO DAC*/
104 3     TEMPOR_BIT_OVR = LOW ( TEMPOR_WORD);
105 3     PORT_1_BIT_3 = TEMPOR_BIT.B7;
106 3     PORT_1_BIT_2 = TEMPOR_BIT.B6;
107 3     PORT_1_BIT_1 = TEMPOR_BIT.B5;
108 3     PORT_1_BIT_0 = TEMPOR_BIT.B4;
109 3     END;

110 1 END DAC_UPDATE;

111 2 ANALYSIS: PROCEDURE;
    /*THIS PROCEDURE PERFORMS THE ANALYSIS WITHIN EACH DESIGNATED
    TIME ZONE*/

112 3     DO CASE ZONE_I;

113 3     ; /*ZONE 0; AWAITING START*/

114 4     DO; /*ZONE 1; NO PEAKS EXPECTED WITHIN ZONE*/
115 4     IF ZONE_1=0 THEN
116 5     DO; /*ZONE 1 INITIALIZATION*/
117 5     ZONE_1 = 1;
118 5     END;
119 4     IF DAC_COUNTER > PEAK_1 THEN FAIL_ZONE_1 =1;
121 4     END; /*ZONE 1*/

122 4     DO; /*ZONE 2; MAIN PEAK MUST BE WITHIN ZONE*/
123 4     IF ZONE_2=0 THEN
124 5     DO; /*ZONE 2 INITIALIZATION*/
125 5     ZONE_1=0;
```

```

126 5           ZONE_2=1;
127 5           END;
128 4           IF DAC COUNTER > PEAK_2 THEN PASS_ZONE_2=1;
130 4           END; /*ZONE 2*/
131 4           DO; /*ZONE 3; NO PEAKS EXPECTED WITHIN ZONE*/
132 4             IF ZONE_3=0 THEN
133 5               DO; /*ZONE 3 INITIALIZATION*/
134 5                 ZONE_2=0;
135 5                 ZONE_3=1;
136 5                 PEAK_COUNTER=0000H;
137 5             END;
           /*MAINTAIN PEAK COUNTER*/
138 4           IF UP_DNNOT_FLAG = 1 THEN
139 5             DO;
140 5               IF PEAK_COUNTER < 0FFFFH THEN
141 5                 PEAK_COUNTER = PEAK_COUNTER + 1;
142 5               END;
143 4             ELSE
144 5               DO;
145 5                 IF PEAK_COUNTER > 0000H THEN
146 5                   PEAK_COUNTER = PEAK_COUNTER - 1;
147 5                 END;
148 4               IF PEAK_COUNTER > PEAK_3 THEN FAIL_ZONE_3 =1;
149 4             END; /*ZONE 3*/

150 4           DO; /*ZONE 4; STOP*/
151 4             IF ZONE_4=0 THEN
152 5               DO; /*ZONE 4 INITIALIZATION*/
153 5                 ZONE_3=0;
154 5                 ZONE_4=1;
155 5               END;
156 4             END; /*ZONE 4*/
157 3           END; /*DO CASE*/
158 1           END ANALYSIS;

159 2           SWITCH: PROCEDURE;

           /*THIS ROUTINE SAMPLES THE START_STOP SW FOR CLOSURE.
           THE START FLAG IS TOGGLED ON A LOW TO HIGH TRANSITION OF
           THE SWITCH. DEBOUNCE IS PROVIDED BY CALLING THIS ROUTINE
           AT 10 M SEC INTERVALS.*/

160 2           START_N=START_STOP_SW;
161 2           IF START_N=1 AND START_P=0 THEN START=NOT START; /*TOGGLE
                                                                START*/
163 2           START_P=START_N; /*SAVE NEW SWITCH VALUE*/
164 1           END SWITCH;

165 2           TIME: PROCEDURE;
           /*THIS ROUTINE MAINTAINS THE TIMING FLAGS USED TO CONTROL
           THE RUNNING OF THE PROGRAM*/

166 2           IF START=0 THEN
167 3             DO;

```

```

168 3          RUN=0;
169 3          FINISH=0;
170 3          ZONE_1=0;
171 3          ZONE_2=0;
172 3          ZONE_3=0;
173 3          ZONE_4=0;
174 3          ZONE_I=0;
175 3          END;

176 2          IF (START=1) AND (RUN=0) AND (FINISH=0) THEN
177 3              DO;
178 3                  FAIL_ZONE_1 = 0;
179 3                  PASS_ZONE_2 = 0;
180 3                  FAIL_ZONE_3 = 0;
181 3                  RUN_COUNTER = 0000H;
182 3                  RUN = 1;
183 3              END;
184 2          IF (START=1) AND (RUN=1) AND (ZONE_4=1) THEN
185 3              DO; /*FINISH*/
186 3                  FINISH = 1;
187 3                  RUN = 0;
188 3              END;
189 1          END TIME;

190 2          LITE: PROCEDURE;

```

/*THIS ROUTINE MAINTAINS THE LED OUTPUT DISPLAY. THE FIRST PORTION IS USED TO HELP ZERO THE BRIDGE. WHEN THE BRIDGE IS ZERO THE GREEN LED WILL BE ON. TWO MORE BANDS (YELLOW, RED) ARE USED TO INDICATE THE MAGNITUDE AND DIRECTION (HI, LO) OF THE OFFSET FROM ZERO. TO START THE RUN THE GREEN LED MUST BE ON INDICATING THAT THE BRIDGE HAS BEEN ZEROED. THE OTHER PORTION OF THE ROUTINE MAINTAINS THE RUN, FAIL, AND PASS LED'S*/

```

191 2          WINDOW = 6;
192 2          IF DAC_COUNTER=0      THEN WINDOW=WINDOW-1;
194 2          IF DAC_COUNTER < WINDOW_1 THEN WINDOW=WINDOW-1;
196 2          IF DAC_COUNTER < WINDOW_2 THEN WINDOW=WINDOW-1;
198 2          IF DAC_COUNTER < WINDOW_3 THEN WINDOW=WINDOW-1;
200 2          IF DAC_COUNTER < WINDOW_4 THEN WINDOW=WINDOW-1;
202 2          IF DAC_COUNTER < WINDOW_5 THEN WINDOW=WINDOW-1;
204 2          IF DAC_COUNTER = OFFFH  THEN WINDOW=WINDOW;
206 3          DO CASE WINDOW;
207 4              DO; /*CASE 0- VALUE AT MINIMUM*/
208 4                  LO_RED_LED=BLINK; /*BLINK LOW RED LED*/
209 4                  LO_YEL_LED=0;
210 4                  ZERO_GRN_LED=0;
211 4                  HI_YEL_LED=0;
212 4                  HI_RED_LED=0;
213 4              END;
214 4              DO; /*CASE 1- VALUE BETWEEN MINIMUM AND WINDOW_1*/
215 4                  LO_RED_LED=1; /*LOW RED LED ON*/
216 4                  LO_YEL_LED=0;

```

```

217 4          ZERO GRN LED=0;
218 4          HI_YEL_LED=0;
219 4          HI_RED_LED=0;
220 4      END;
221 4      DO; /*CASE 2- VALUE BETWEEN WINDOW_1 AND WINDOW_2*/
222 4          LO_RED_LED=0;
223 4          LO_YEL_LED=1; /*LOW YELLOW LED ON*/
224 4          ZERO GRN LED=0;
225 4          HI_YEL_LED=0;
226 4          HI_RED_LED=0;
227 4      END;
228 4      DO; /*CASE 3- VALUE BETWEEN WINDOW_2 AND WINDOW_3*/
229 4          LO_RED_LED=0;
230 4          LO_YEL_LED=0;
231 4          ZERO GRN LED=1; /*WITHIN ZERO LIMITS*/
232 4          HI_YEL_LED=0;
233 4          HI_RED_LED=0;
234 4      END;
235 4      DO; /*CASE 4- VALUE BETWEEN WINDOW_3 AND WINDOW_4*/;
236 4          LO_RED_LED=0;
237 4          LO_YEL_LED=0;
238 4          ZERO GRN LED=0;
239 4          HI_YEL_LED=1; /*HI YELLOW LED ON*/
240 4          HI_RED_LED=0;
241 4      END;
242 4      DO; /*CASE 5- VALUE BETWEEN WINDOW_4 AND WINDOW_5*/
243 4          LO_RED_LED=0;
244 4          LO_YEL_LED=0;
245 4          ZERO GRN LED=0;
246 4          HI_YEL_LED=0;
247 4          HI_RED_LED=1; /*HI RED LED ON*/
248 4      END;
249 4      DO; /*CASE 6- VALUE AT MAXIMUM*/
250 4          LO_RED_LED=0;
251 4          LO_YEL_LED=0;
252 4          ZERO GRN LED=0;
253 4          HI_YEL_LED=0;
254 4          HI_RED_LED=BLINK; /*BLINK HI RED LED*/
255 4      END;
256 3      END; /*DO CASE*/

/* RUN LED CONTROL*/
257 2      IF START=0 THEN RUN_LED=0;
259 2      IF (RUN=1) AND (START=1) THEN RUN_LED=1;
261 2      IF (FINISH=1) AND (START=1) THEN RUN_LED=BLINK;

/*FAIL LED CONTROL*/
263 2      IF START=0 THEN FAIL_LED=0;
265 2      IF (START=1) AND (FINISH=0) THEN
266 2          FAIL_LED=FAIL_ZONE_1 OR FAIL_ZONE_3;
267 2      IF FINISH=1 THEN
268 2          FAIL_LED=FAIL_ZONE_1 OR FAIL_ZONE_3 OR NOT
                PASS_ZONE_2;

```



```

                /* PASS LED CONTROL*/
269 2          IF START=0 THEN PASS_LED=0;
271 2          IF (START=1) AND (FINISH=0) THEN
272 2              PASS_LED=PASS_ZONE_2;
273 2          IF FINISH=1 THEN
274 2              PASS_LED=NOT FAIL_LED;
275 1          END LITE;

```

\$EJECT

```

276 2          ZONE: PROCEDURE;
                /*THIS PROCEDURE MAINTAINS THE RUN COUNTER AND ESTABLISHES
                A TIME ZONE WHICH IS USED BY THE ANALYSIS PROCEDURE.*/

277 2          IF RUN=1 THEN
278 3              DO;
279 3                  IF RUN_COUNTER < TIME_4 THEN ZONE_I=4;
281 3                  IF RUN_COUNTER < TIME_3 THEN ZONE_I=3;
283 3                  IF RUN_COUNTER < TIME_2 THEN ZONE_I=2;
285 3                  IF RUN_COUNTER < TIME_1 THEN ZONE_I=1;
287 3                  RUN_COUNTER=RUN_COUNTER+1;
288 3              END;
289 1          END ZONE;

```

\$EJECT

/******

/****** RESET ENTRY *****

/*INITIALIZATION*/

```

290 1          SP=6FH; /*SET UP STACK POINTER*/
291 1          TMOD=00010011B; /*SET UP TIMER/COUNTER MODE REGISTER*/
292 1          TCON=01000000B; /*SET UP TIMER/COUNTER CONTROL/STATUS
                                REGISTER*/
293 1          SCON=00000000B; /*SET UP SERIAL PORT CONTROL/STATUS
                                REGISTER*/
294 1          IP=00011111B; /*SET UP INTERRUPT PRIORITY REGISTER*/
295 1          IE=00001000B; /*SET UP INTERRUPT ENABLE REGISTER*/
296 1          EA=1; /*ENABLE INTERRUPTS*/

297 1          START=0; /*INITIALIZE RUNNING PROGRAM*/
298 1          ZONE_I=0;
299 1          DAC_COUNTER = 0000H;

```

/******

/*MAIN PROGRAM*/

```

300 2          DO WHILE 1; /*DO BLOCK FOREVER*/
301 3              DO WHILE TAG_0_INTR3=1; /*THIS DO LOOP IS DONE ONCE
                                EVERY .25 MSEC*/

```

```

302 3      CALL DAC_UPDATE;
303 3      CALL ANALYSIS;
304 3      TAG_O_INTR3=0;
305 3      END;
306 3      DO WHILE TAG_1_INTR3=1; /*THIS DO LOOP IS DONE ONCE
                                EVERY 10 MSEC*/
307 3          CALL SWITCH;
308 3          CALL TIME;
309 3          TAG_1_INTR3=0;
310 3      END;
311 3      DO WHILE TAG_2_INTR3=1; /*THIS DO LOOP IS DONE ONCE
                                EVERY 330 MSEC*/
312 3          CALL LITE;
313 3          TAG_2_INTR3=0;
314 3      END;
315 3      DO WHILE TAG_3_INTR3=1; /*THIS DO LOOP IS DONE ONCE
                                EVERY SECOND*/
316 3          CALL ZONE;
317 3          TAG_3_INTR3=0;
318 3      END;
319 2      END; /*END WHILE 1 LOOP*/
320 1      END NASA00; /*END MODULE NASA00*/
          ; PROCEDURE NASA00 (START)
          ; STATEMENT # 67
          ; PROCEDURE TIC_COUNT (START)
          ; STATEMENT # 68
0000      0500      F          INC      TEN_MSEC
          ; STATEMENT # 69
0002      D200      F          SETB    TAG_0_INTR3
          ; STATEMENT # 70
0004      E500      F          MOV     A,TEN_MSEC
0006      B4282A    CJNE    A,#28H,THEN?1
          ; STATEMENT # 72
0009      750000   F          MOV     TEN_MSEC,#00H
          ; STATEMENT # 73
000C      0500      F          INC     HUND_MSEC
          ; STATEMENT # 74
000E      D200      F          SETB    TAG_1_INTR3
          ; STATEMENT # 75
0010      E500      F          MOV     A,HUND_MSEC
0012      6421      XRL     A,#21H
0014      6005      JZ      BOOL?59
0016      E500      F          MOV     A,HUND_MSEC
0018      B44302   CJNE    A,#43H,THEN?2
001B      BOOL?59:
          ; STATEMENT # 76
001B      D200      F          SETB    TAG_2_INTR3
          ; STATEMENT # 77
001D      THEN?2:
001D      E500      F          MOV     A,HUND_MSEC
001F      B46411   CJNE    A,#64H,THEN?3
          ; STATEMENT # 79
0022      750000   F          MOV     HUND_MSEC,#00H
          ; STATEMENT # 80

```

```

0025      0500    F          INC    SEC
                                ; STATEMENT # 81
0027      D200    F          SETB   TAG_3_INTR3
                                ; STATEMENT # 82
0029      B200    F          CPL     BLINK
                                ; STATEMENT # 83
002B      E500    F          MOV     A,SEC
002D      B40A03          CJNE   A,#0AH,THEN?4
                                ; STATEMENT # 84
0030      750000 F          MOV     SEC,#00H
                                ; STATEMENT # 85
0033              THEN?4:
                                ; STATEMENT # 86
0033              THEN?3:
                                ; STATEMENT # 87
0033              THEN?1:
0033      22              RET
                                ; PROCEDURE TIC_COUNT (END)
                                ; STATEMENT # 88
                                ; PROCEDURE DAC_UPDATE (START)
                                ; STATEMENT # 89
0034      A2B4          MOV     C,DAC_COMP
0036      9200    F          MOV     UP_DNNOT_FLAG,C
                                ; STATEMENT # 90
0038      A200    F          MOV     C,UP_DNNOT_FLAG
003A      B3              CPL     C
003B      4026          JC      THEN?5
                                ; STATEMENT # 92
003D      AE00    F          MOV     R6,DAC_COUNTER
003F      AF00    F          MOV     R7,DAC_COUNTER+0001H
0041      900000 F          MOV     DPTR,#DAC_MAX_COUNT
0044      E4              CLR     A
0045      93              MOVC   A,@A+DPTR
0046      FC              MOV     R4,A
0047      7401          MOV     A,#01H
0049      93              MOVC   A,@A+DPTR
004A      FD              MOV     R5,A
004B      EF              MOV     A,R7
004C      C3              CLR     C
004D      9D              SUBB   A,R5
004E      EE              MOV     A,R6
004F      9C              SUBB   A,R4
0050      400A          JC      THEN?6
                                ; STATEMENT # 93
0052      900000 F          MOV     DPTR,#DAC_MAX_COUNT
0055      7800    F          MOV     R0,#DAC_COUNTER
0057      120000 F          LCALL  ?P0008
                                ; STATEMENT # 94
005A      8005          SJMP   ELSE?7
005C              THEN?6:
005C      7800    F          MOV     R0,#DAC_COUNTER
005E      120000 F          LCALL  ?P0024
                                ; STATEMENT # 95
0061              ELSE?7:

```

```

                                ; STATEMENT # 96
0061      8013      SJMP  ELSE?8
0063      THEN?5:
                                ; STATEMENT # 97
0063      E500      F      MOV   A,DAC_COUNTER+0001H
0065      4500      F      ORL   A,DAC_COUNTER
0067      7008      JNZ   THEN?9
                                ; STATEMENT # 98
0069      750000    F      MOV   DAC_COUNTER+0001H,#00H
006C      750000    F      MOV   DAC_COUNTER,#00H
                                ; STATEMENT # 99
006F      8005      SJMP  ELSE?10
0071      THEN?9:
0071      7800      F      MOV   RO,#DAC_COUNTER
0073      120000    F      LCALL ?P0026
                                ; STATEMENT # 100
0076      ELSE?10:
                                ; STATEMENT # 101
0076      ELSE?8:
                                ; STATEMENT # 102
0076      AE00      F      MOV   R6,DAC_COUNTER
0078      AF00      F      MOV   R7,DAC_COUNTER+0001H
007A      7404      MOV   A,#04H
007C      120000    F      LCALL ?P0032
007F      8E00      F      MOV   TEMPOR_WORD,R6
0081      8F00      F      MOV   TEMPOR_WORD+0001H,R7
                                ; STATEMENT # 103
0083      E500      F      MOV   A,TEMPOR_WORD
0085      F580      MOV   PORT_0,A
                                ; STATEMENT # 104
0087      E500      F      MOV   A,TEMPOR_WORD+0001H
0089      F500      F      MOV   TEMPOR_BIT_OVR,A
                                ; STATEMENT # 105
008B      A200      F      MOV   C,TEMPOR_BIT.B7
008D      9293      MOV   PORT_1_BIT_3,C
                                ; STATEMENT # 106
008F      A200      F      MOV   C,TEMPOR_BIT.B6
0091      9292      MOV   PORT_1_BIT_2,C
                                ; STATEMENT # 107
0093      A200      F      MOV   C,TEMPOR_BIT.B5
0095      9291      MOV   PORT_1_BIT_1,C
                                ; STATEMENT # 108
0097      A200      F      MOV   C,TEMPOR_BIT.B4
0099      9290      MOV   PORT_1_BIT_0,C
                                ; STATEMENT # 110
009B      22      RET
                                ; PROCEDURE DAC_UPDATE (END)
                                ; STATEMENT # 111
                                ; PROCEDURE ANALYSIS (START)
                                ; STATEMENT # 112
009C      E500      F      MOV   A,ZONE_I
009E      900000    F      MOV   DPTR,#CASE?JMPTBL?03BE
00A1      25E0      ADD   A,ACC
00A3      73      JMP   @A+DPTR

```

```

00A4          CASE?98:
                                ; STATEMENT # 113
00A4      0100      F          AJMP   CASEEND?11
00A6          CASE?99:
                                ; STATEMENT # 115
00A6      A200      F          MOV    C,ZONE_1
00A8      4002          JC      THEN?12
                                ; STATEMENT # 117
00AA      D200      F          SETB   ZONE_1
                                ; STATEMENT # 119
00AC          THEN?12:
00AC      AE00      F          MOV    R6,DAC_COUNTER
00AE      AF00      F          MOV    R7,DAC_COUNTER+0001H
00B0      900000    F          MOV    DPTR,#PEAK_1
00B3      E4          CLR    A
00B4      93          MOVC   A,@A+DPTR
00B5      FC          MOV    R4,A
00B6      7401      MOV    A,#01H
00B8      93          MOVC   A,@A+DPTR
00B9      FD          MOV    R5,A
00BA      EF          MOV    A,R7
00BB      D3          SETB   C
00BC      9D          SUBB   A,R5
00BD      EE          MOV    A,R6
00BE      9C          SUBB   A,R4
00BF      4002          JC      THEN?13
                                ; STATEMENT # 120
00C1      D200      F          SETB   FAIL_ZONE_1
                                ; STATEMENT # 121
00C3          THEN?13:
00C3      8074          SJMP   CASEEND?11
00C5          CASE?100:
                                ; STATEMENT # 123
00C5      A200      F          MOV    C,ZONE_2
00C7      4004          JC      THEN?14
                                ; STATEMENT # 125
00C9      C200      F          CLR    ZONE_1
                                ; STATEMENT # 126
00CB      D200      F          SETB   ZONE_2
                                ; STATEMENT # 128
00CD          THEN?14:
00CD      AE00      F          MOV    R6,DAC_COUNTER
00CF      AF00      F          MOV    R7,DAC_COUNTER+0001H
00D1      900000    F          MOV    DPTR,#PEAK_2
00D4      E4          CLR    A
00D5      93          MOVC   A,@A+DPTR
00D6      FC          MOV    R4,A
00D7      7401      MOV    A,#01H
00D9      93          MOVC   A,@A+DPTR
00DA      FD          MOV    R5,A
00DB      EF          MOV    A,R7
00DC      D3          SETB   C
00DD      9D          SUBB   A,R5
00DE      EE          MOV    A,R6

```

```

00DF      9C          SUBB  A,R4
00E0      4002        JC    THEN?15
                                ; STATEMENT # 129
00E2      D200      F      SETB  PASS_ZONE_2
                                ; STATEMENT # 130
00E4                                THEN?15:
00E4      8053          SJMP  CASEEND?11
00E6                                CASE?101:
                                ; STATEMENT # 132
00E6      A200      F      MOV   C,ZONE_3
00EB      400A          JC    THEN?16
                                ; STATEMENT # 134
00EA      C200      F      CLR   ZONE_2
                                ; STATEMENT # 135
00EC      D200      F      SETB  ZONE_3
                                ; STATEMENT # 136
00EE      750000    F      MOV   PEAK_COUNTER+0001H,#00H
00F1      750000    F      MOV   PEAK_COUNTER,#00H
                                ; STATEMENT # 138
00F4                                THEN?16:
00F4      A200      F      MOV   C,UP_DNNOT_FLAG
00F6      B3          CPL   C
00F7      4014          JC    THEN?17
                                ; STATEMENT # 140
00F9      AE00      F      MOV   R6,PEAK_COUNTER
00FB      AF00      F      MOV   R7,PEAK_COUNTER+0001H
00FD      74FF          MOV   A,#0FFH
00FF      D3          SETB  C
0100      9F          SUBB  A,R7
0101      74FF          MOV   A,#0FFH
0103      9E          SUBB  A,R6
0104      4005          JC    THEN?18
                                ; STATEMENT # 141
0106      7800      F      MOV   R0#PEAK_COUNTER
0108      120000    F      LCALL ?P0024
                                ; STATEMENT # 142
010B                                THEN?18:
                                ; STATEMENT # 143
010B      800B          SJMP  ELSE?19
010D                                THEN?17:
                                ; STATEMENT # 144
010D      E500      F      MOV   A,PEAK_COUNTER+0001H
010F      4500      F      ORL   A,PEAK_COUNTER
0111      6005          JZ    THEN?20
                                ; STATEMENT # 145
0113      7800      F      MOV   R0,#PEAK_COUNTER
0115      120000    F      LCALL ?P0026
                                ; STATEMENT # 146
0118                                THEN?20:
                                ; STATEMENT # 147
0118                                ELSE?19:
0118      AE00      F      MOV   R6,PEAK_COUNTER
011A      AF00      F      MOV   R7,PEAK_COUNTER+0001H
011C      900000    F      MOV   DPTR,#PEAK_3

```

```

011F      E4          CLR      A
0120      93          MOVC     A,@A+DPTR
0121      FC          MOV      R4,A
0122      7401       MOV      A,#01H
0124      93          MOVC     A,@A+DPTR
0125      FD          MOV      R5,A
0126      EF          MOV      A,R7
0127      D3          SETB    C
0128      9D          SUBB    A,R5
0129      EE          MOV      A,R6
012A      9C          SUBB    A,R4
012B      4002       JC      THEN?21
                                ; STATEMENT # 148
012D      D200       F          SETB    FAIL_ZONE_3
                                ; STATEMENT # 149
012F                                THEN?21:
012F      8008       SJMP    CASEEND?11
0131                                CASE?102:
                                ; STATEMENT # 151
0131      A200       F          MOV      C,ZONE_4
0133      4004       JC      THEN?22
                                ; STATEMENT # 153
0135      C200       F          CLR      ZONE_3
                                ; STATEMENT # 154
0137      D200       F          SETB    ZONE_4
                                ; STATEMENT # 156
0139                                THEN?22:
                                ; STATEMENT # 157
0139                                CASEEND?11:
                                ; STATEMENT # 158
0139      22          RET
                                ; PROCEDURE ANALYSIS (END)
                                ; STATEMENT # 159
                                ; PROCEDURE SWITCH (START)
                                ; STATEMENT # 160
013A      A2B3       MOV      C,START_STOP_SW
013C      9200       F          MOV      START_N,C
                                ; STATEMENT # 161
013E      A200       F          MOV      C,START_N
0140      B3          CPL      C
0141      B3          CPL      C
0142      5005       JNC     BOOL?61
0144      A200       F          MOV      C,START_P
0146      B3          CPL      C
0147      4002       JC      BOOL?63
0149                                BOOL?61:
0149      8002       SJMP    THEN?23
014B                                BOOL?63:
                                ; STATEMENT # 162
014B      B200       F          CPL      START
                                ; STATEMENT # 163
014D                                THEN?23:
014D      A200       F          MOV      C,START_N
014F      9200       F          MOV      START_P,C

```

```

                                ; STATEMENT # 164
0151      22                RET
                                ; PROCEDURE SWITCH (END)
                                ; STATEMENT # 165
                                ; PROCEDURE TIME (START)
                                ; STATEMENT # 166
0152      A200      F      MOV      C,START
0154      400F                JC      THEN?24
                                ; STATEMENT # 168
0156      C200      F      CLR      RUN
                                ; STATEMENT # 169
0158      C200      F      CLR      FINISH
                                ; STATEMENT # 170
015A      C200      F      CLR      ZONE_1
                                ; STATEMENT # 171
015C      C200      F      CLR      ZONE_2
                                ; STATEMENT # 172
015E      C200      F      CLR      ZONE_3
                                ; STATEMENT # 173
0160      C200      F      CLR      ZONE_4
                                ; STATEMENT # 174
0162      750000  F      MOV      ZONE_1,#00H
                                ; STATEMENT # 176
0165                THEN?24:
0165      A200      F      MOV      C,START
0167      B3                CPL      C
0168      B3                CPL      C
0169      500A                JNC     BOOL?65
016B      A200      F      MOV      C,RUN
016D      B3                CPL      C
016E      5005                JNC     BOOL?67
0170      A200      F      MOV      C,FINISH
0172      B3                CPL      C
0173      4002                JC      BOOL?69
0175                BOOL?67:
0175                BOOL?65:
0175      800E                SJMP   THEN?25
0177                BOOL?69:
                                ; STATEMENT # 178
0177      C200      F      CLR      FAIL_ZONE_1
                                ; STATEMENT # 179
0179      C200      F      CLR      PASS_ZONE_2
                                ; STATEMENT # 180
017B      C200      F      CLR      FAIL_ZONE_3
                                ; STATEMENT # 181
017D      750000  F      MOV      RUN_COUNTER+0001H,#00H
0180      750000  F      MOV      RUN_COUNTER,#00H
                                ; STATEMENT # 182
0183      D200      F      SETB    RUN
                                ; STATEMENT # 184
0185                THEN?25:
0185      A200      F      MOV      C,START
0187      B3                CPL      C
0188      B3                CPL      C

```



```

0189      500C      JNC      BOOL?71
018B      A200      F      MOV      C,RUN
018D      B3        CPL      C
018E      B3        CPL      C
018F      5006      JNC      BOOL?73
0191      A200      F      MOV      C,ZONE_4
0193      B3        CPL      C
0194      B3        CPL      C
0195      4002      JC       BOOL?75
0197      BOOL?73:
0197      BOOL?71:
0197      8004      SJMP     THEN?26
0199      BOOL?75:
                                ; STATEMENT # 186
0199      D200      F      SETB     FINISH
                                ; STATEMENT # 187
019B      C200      F      CLR      RUN
                                ; STATEMENT # 189
019D      THEN?26:
019D      22        RET
                                ; PROCEDURE TIME (END)
                                ; STATEMENT # 190
                                ; PROCEDURE LITE (START)
                                ; STATEMENT # 191
019E      750006    F      MOV      WINDOW,#06H
                                ; STATEMENT # 192
01A1      E500      F      MOV      A,DAC_COUNTER+0001H
01A3      4500      F      ORL      A,DAC_COUNTER
01A5      7002      JNZ     THEN?27
                                ; STATEMENT # 193
01A7      1500      F      DEC      WINDOW
                                ; STATEMENT # 194
01A9      THEN?27:
01A9      AE00      F      MOV      R6,DAC_COUNTER
01AB      AF00      F      MOV      R7,DAC_COUNTER+0001H
01AD      900000    F      MOV      DPTR,#WINDOW_1
01B0      E4        CLR      A
01B1      93        MOVC     A,@A+DPTR
01B2      FC        MOV      R4,A
01B3      7401      MOV      A,#01H
01B5      93        MOVC     A,@A+DPTR
01B6      FD        MOV      R5,A
01B7      ED        MOV      A,R5
01B8      D3        SETB     C
01B9      9F        SUBB     A,R7
01BA      EC        MOV      A,R4
01BB      9E        SUBB     A,R6
01BC      4002      JC       THEN?28
                                ; STATEMENT # 195
01BE      1500      F      DEC      WINDOW
                                ; STATEMENT # 196
01C0      THEN?28:
01C0      AE00      F      MOV      R6,DAC_COUNTER
01C2      AF00      F      MOV      R7,DAC_COUNTER+0001H

```

```

01C4      900000 F          MOV    DPTR,#WINDOW_2
01C7      E4              CLR    A
01C8      93              MOVC   A,@A+DPTR
01C9      FC              MOV    R4,A
01CA      7401            MOV    A,#01H
01CC      93              MOVC   A,@A+DPTR
01CD      FD              MOV    R5,A
01CE      ED              MOV    A,R5
01CF      D3              SETB  C
01D0      9F              SUBB  A,R7
01D1      EC              MOV    A,R4
01D2      9E              SUBB  A,R6
01D3      4002            JC    THEN?29
                                ; STATEMENT # 197
01D5      1500 F          DEC    WINDOW
                                ; STATEMENT # 198
01D7      THEN?29:
01D7      AE00 F          MOV    R6,DAC_COUNTER
01D9      AF00 F          MOV    R7,DAC_COUNTER+0001H
01DB      900000 F        MOV    DPTR,#WINDOW_3
01DE      E4              CLR    A
01DF      93              MOVC   A,@A+DPTR
01E0      FC              MOV    R4,A
01E1      7401            MOV    A,#01H
01E3      93              MOVC   A,@A+DPTR
01E4      FD              MOV    R5,A
01E5      ED              MOV    A,R5
01E6      D3              SETB  C
01E7      9F              SUBB  A,R7
01E8      EC              MOV    A,R4
01E9      9E              SUBB  A,R6
01EA      4002            JC    THEN?30
                                ; STATEMENT # 199
01EC      1500 F          DEC    WINDOW
                                ; STATEMENT # 200
01EE      THEN?30:
01EE      AE00 F          MOV    R6,DAC_COUNTER
01F0      AF00 F          MOV    R7,DAC_COUNTER+0001H
01F2      900000 F        MOV    DPTR,#WINDOW_4
01F5      E4              CLR    A
01F6      93              MOVC   A,@A+DPTR
01F7      FC              MOV    R4,A
01F8      7401            MOV    A,#01H
01FA      93              MOVC   A,@A+DPTR
01FB      FD              MOV    R5,A
01FC      ED              MOV    A,R5
01FD      D3              SETB  C
01FE      9F              SUBB  A,R7
01FF      EC              MOV    A,R4
0200      9E              SUBB  A,R6
0201      4002            JC    THEN?31
                                ; STATEMENT # 201
0203      1500 F          DEC    WINDOW
                                ; STATEMENT # 202

```

```

0205          THEN?31:
0205    AE00    F      MOV    R6,DAC_COUNTER
0207    AF00    F      MOV    R7,DAC_COUNTER+0001H
0209    900000 F      MOV    DPTR,#WINDOW_5
020C    E4      CLR    A
020D    93      MOV    A,@A+DPTR
020E    FC      MOV    R4,A
020F    7401    MOV    A,#01H
0211    93      MOV    A,@A+DPTR
0212    FD      MOV    R5,A
0213    ED      MOV    A,R5
0214    D3      SETB  C
0215    9F      SUBB  A,R7
0216    EC      MOV    A,R4
0217    9E      SUBB  A,R6
0218    4002    JC     THEN?32
                                ; STATEMENT # 203
021A    1500    F      DEC    WINDOW
                                ; STATEMENT # 204
021C          THEN?32:
021C    AE00    F      MOV    R6,DAC_COUNTER
021E    AF00    F      MOV    R7,DAC_COUNTER+0001H
0220    EF      MOV    A,R7
0221    B4FF07  CJNE  A,#0FFH,THEN?33
0224    EE      MOV    A,R6
0225    B40F03  CJNE  A,#0FH,THEN?33
                                ; STATEMENT # 205
0228    850000 F      MOV    WINDOW,WINDOW
                                ; STATEMENT # 206
022B          THEN?33:
022B    E500    F      MOV    A,WINDOW
022D    900000 F      MOV    DPTR,#CASE?JMPTBL?03BE+000AH
0230    25E0    ADD   A,ACC
0232    73      JMP   @A+DPTR
0233          CASE?103:
                                ; STATEMENT # 208
0233    A200    F      MOV    C,BLINK
0235    92A4    MOV   LO_RED_LED,C
                                ; STATEMENT # 209
0237    C2A3    CLR   LO_YEL_LED
                                ; STATEMENT # 210
0239    C2A2    CLR   ZERO_GRN_LED
                                ; STATEMENT # 211
023B    C2A1    CLR   HI_YEL_LED
                                ; STATEMENT # 212
023D    C2A0    CLR   HI_RED_LED
                                ; STATEMENT # 213
023F    8048    SJMP  CASEEND?34
0241          CASE?104:
                                ; STATEMENT # 215
0241    D2A4    SETB  LO_RED_LED
                                ; STATEMENT # 216
0243    C2A3    CLR   LO_YEL_LED
                                ; STATEMENT # 217

```

```

0245      C2A2          CLR    ZERO_GRN_LED
                                ; STATEMENT # 218
0247      C2A1          CLR    HI_YEL_LED
                                ; STATEMENT # 219
0249      C2A0          CLR    HI_RED_LED
                                ; STATEMENT # 220
024B      803C          SJMP   CASEND?34
024D      CASE?105:
                                ; STATEMENT # 222
024D      C2A4          CLR    LO_RED_LED
                                ; STATEMENT # 223
024F      D2A3          SETB  LO_YEL_LED
                                ; STATEMENT # 224
0251      C2A2          CLR    ZERO_GRN_LED
                                ; STATEMENT # 225
0253      C2A1          CLR    HI_YEL_LED
                                ; STATEMENT # 226
0255      C2A0          CLR    HI_RED_LED
                                ; STATEMENT # 227
0257      8030          SJMP   CASEND?34
0259      CASE?106:
                                ; STATEMENT # 229
0259      C2A4          CLR    LO_RED_LED
                                ; STATEMENT # 230
025B      C2A3          CLR    LO_YEL_LED
                                ; STATEMENT # 231
025D      D2A2          SETB  ZERO_GRN_LED
                                ; STATEMENT # 232
025F      C2A1          CLR    HI_YEL_LED
                                ; STATEMENT # 233
0261      C2A0          CLR    HI_RED_LED
                                ; STATEMENT # 234
0263      8024          SJMP   CASEND?34
0265      CASE?107:
                                ; STATEMENT # 236
0265      C2A4          CLR    LO_RED_LED
                                ; STATEMENT # 237
0267      C2A3          CLR    LO_YEL_LED
                                ; STATEMENT # 238
0269      C2A2          CLR    ZERO_GRN_LED
                                ; STATEMENT # 239
026B      D2A1          SETB  HI_YEL_LED
                                ; STATEMENT # 240
026D      C2A0          CLR    HI_RED_LED
                                ; STATEMENT # 241
026F      8018          SJMP   CASEND?34
0271      CASE?108:
                                ; STATEMENT # 243
0271      C2A4          CLR    LO_RED_LED
                                ; STATEMENT # 244
0273      C2A3          CLR    LO_YEL_LED
                                ; STATEMENT # 245
0275      C2A2          CLR    ZERO_GRN_LED
                                ; STATEMENT # 246

```

```

0277      C2A1          CLR      HI_YEL_LED          ; STATEMENT # 247
0279      D2A0          CLR      HI_RED_LED          ; STATEMENT # 248
027B      800C          SJMP    CASEEND?34
027D      CASE?109:
                                ; STATEMENT # 250
027D      C2A4          CLR      LO_RED_LED          ; STATEMENT # 251
027F      C2A3          CLR      LO_YEL_LED          ; STATEMENT # 252
0281      C2A2          CLR      ZERO_GRN_LED         ; STATEMENT # 253
0283      C2A1          CLR      HI_YEL_LED          ; STATEMENT # 254
0285      A200      F      MOV      C,BLINK
0287      92A0          MOV      HI_RED_LED,C
                                ; STATEMENT # 256
0289      CASEEND?34:
                                ; STATEMENT # 257
0289      A200      F      MOV      C,START
028B      4002          JC       THEN?35
                                ; STATEMENT # 258
028D      C2A7          CLR      RUN_LED
                                ; STATEMENT # 259
028F      THEN?35:
028F      A200      F      MOV      C,RUN
0291      B3           CPL      C
0292      B3           CPL      C
0293      5006          JNC     BOOL?77
0295      A200      F      MOV      C,START
0297      B3           CPL      C
0298      B3           CPL      C
0299      4002          JC       BOOL?79
029B      BOOL?77
029B      8002          SJMP    THEN?36
029D      BOOL?79
                                ; STATEMENT # 260
029D      D2A7          SETB   RUN_LED          ; STATEMENT # 261
029F      THEN?36:
029F      A200      F      MOV      C,FINISH
02A1      B3           CPL      C
02A2      B3           CPL      C
02A3      5006          JNC     BOOL?81
02A5      A200      F      MOV      C,START
02A7      B3           CPL      C
02A8      B3           CPL      C
02A9      4002          JC       BOOL?83
02AB      BOOL?81:
02AB      8004          SJMP    THEN?37
02AD      BOOL?83:
                                ; STATEMENT # 262
02AD      A200      F      MOV      C,BLINK

```

```

02AF      92A7          MOV    RUN_LED,C
                                           ; STATEMENT # 263
02B1          THEN?37:
02B1      A200      F      MOV    C,START
02B3      4002          JC     THEN?38
                                           ; STATEMENT # 264
02B5      C2A5          CLR    FAIL_LED
                                           ; STATEMENT # 265
02B7          THEN?38:
02B7      A200      F      MOV    C,START
02B9      B3          CPL    C
02BA      B3          CPL    C
02BB      5005          JNC   BOOL?85
02BD      A200      F      MOV    C,FINISH
02BF      B3          CPL    C
02C0      4002          JC     BOOL?87
02C2          BOOL?85
02C2      8006          SJMP  THEN?39
02C4          BOOL?87:
                                           ; STATEMENT # 266
02C4      A200      F      MOV    C,FAIL_ZONE_1
02C6      7200      F      ORL    C,FAIL_ZONE_3
02C8      92A5          MOV    FAIL_LED,C
                                           ; STATEMENT # 267
02CA          THEN?39:
02CA      A200      F      MOV    C,FINISH
02CC      B3          CPL    C
02CD      4011          JC     THEN?40
                                           ; STATEMENT # 268
02CF      A200      F      MOV    C,FAIL_ZONE_1
02D1      7200      F      ORL    C,FAIL_ZONE_3
02D3      4005          JC     BOOL?89
02D5      A200      F      MOV    C,PASS_ZONE_2
02D7      B3          CPL    C
02D8      5003          JNC   BOOL?91
02DA          BOOL?89:
02DA      D3          SETB  C
02DB      8001          SJMP  BOOL?93
02DD          BOOL?91
02DD      C3          CLR    C
02DE          BOOL?93:
02DE      92A5          MOV    FAIL_LED,C
                                           ; STATEMENT # 269
02E0          THEN?40:
02E0      A200      F      MOV    C,START
02E2      4002          JC     THEN?41
                                           ; STATEMENT # 270
02E4      C2A6          CLR    PASS_LED
                                           ; STATEMENT # 271
02E6          THEN?41:
02E6      A200      F      MOV    C,START
02E8      B3          CPL    C
02E9      B3          CPL    C
02EA      5005          JNC   BOOL?94

```

```

02EC    A200    F        MOV    C,FINISH
02EE    B3      CPL    C
02EF    4002   JC     BOOL?96
02F1    BOOL?94:
02F1    8004   SJMP  THEN?42
02F3    BOOL?96:
                                ; STATEMENT # 272
02F3    A200    F        MOV    C,PASS_ZONE_2
02F5    92A6   MOV    PASS_LED,C
                                ; STATEMENT # 273
02F7    THEN?42:
02F7    A200    F        MOV    C,FINISH
02F9    B3      CPL    C
02FA    4005   JC     THEN?43
                                ; STATEMENT # 274
02FC    A2A5   MOV    C,FAIL_LED
02FE    B3      CPL    C
02FF    92A6   MOV    PASS_LED,C
                                ; STATEMENT # 275
0301    THEN?43:
0301    22      RET
                                ; PROCEDURE LITE (END)
                                ; STATEMENT # 276
                                ; PROCEDURE ZONE (START)
                                ; STATEMENT # 277
0302    A200    F        MOV    C,RUN
0304    B3      CPL    C
0305    4065   JC     THEN?44
                                ; STATEMENT # 279
0307    AE00    F        MOV    R6,RUN_COUNTER
0309    AF00    F        MOV    R7,RUN_COUNTER+0001H
030B    900000 F        MOV    DPTR,#TIME_4
030E    E4      CLR    A
030F    93      MOVC   A,@A+DPTR
0310    FC      MOV    R4,A
0311    7401   MOV    A,#01H
0313    93      MOVC   A,@A+DPTR
0314    FD      MOV    R5,A
0315    ED      MOV    A,R5
0316    D3      SETB  C
0317    9F      SUBB  A,R7
0318    EC      MOV    A,R4
0319    9E      SUBB  A,R6
031A    4003   JC     THEN?45
                                ; STATEMENT # 280
031C    750004 F        MOV    ZONE_I,#04H
                                ; STATEMENT # 281
031F    THEN?45:
031F    AE00    F        MOV    R6,RUN_COUNTER
0321    AF00    F        MOV    R7,RUN_COUNTER+0001H
0323    900000 F        MOV    DPTR,#TIME_3
0326    E4      CLR    A
0327    93      MOVR  A,@A+DPTR
0328    FC      MOV    R4,A

```

```

0329      7401          MOV    A,#01H
032B      93          MOVC   A,@A+DPTR
032C      FD          MOV    R5,A
032D      ED          MOV    A,R5
032C      D3          SETB  C
032F      9F          SUBB  A,R7
0330      EC          MOV    A,R4
0331      9E          SUBB  A,R6
0332      4003        JC    THEN?46
                                ; STATEMENT # 282
0334      750003 F    MOV    ZONE_I,#03H
                                ; STATEMENT # 283
0337      THEN?46:
0337      AE00 F      MOV    R6,RUN_COUNTER
0339      AF00 F      MOV    R7,RUN_COUNTER+0001H
033B      900000 F    MOV    DPTR,#TIME_2
033E      E4          CLR   A
033F      93          MOVC  A,@A_DPTR
0340      FC          MOV    R4,A
0341      7401        MOV    A,#01H
0343      93          MOVC  A,@A+DPTR
0344      FD          MOV    R5,A
0345      ED          MOV    A,R5
0346      D3          SETB  C
0347      9F          SUBB  A,R7
0348      EC          MOV    A,R4
0349      9E          SUBB  A,R6
034A      4003        JC    THEN?47
                                ; STATEMENT # 284
034C      750002 F    MOV    ZONE_I#02H
                                ; STATEMENT # 285
034F      THEN?47
034F      AE00 F      MOV    R6,RUN_COUNTER
0351      AF00 F      MOV    R7,RUN_COUNTER+0001H
0353      900000 F    MOV    DPTR,#TIME_1
0356      E4          CLR   A
0357      93          MOVC  A,@A+DPTR
0358      FC          MOV    R4,A
0359      7401        MOV    A,#01H
035B      93          MOVC  A,@A+DPTR
035C      FD          MOV    R5,A
035D      ED          MOV    A,R5
035E      D3          SETB  C
035F      9F          SUBB  A,R7
0360      EC          MOV    A,R4
0361      9E          SUBB  A,R6
0362      4003        JC    THEN?48
                                ; STATEMENT # 286
0364      750001 F    MOV    ZONE_I,#01H
                                ; STATEMENT # 287
0367      THEN?48
0367      7800 F      MOV    RO,#RUN_COUNTER
0369      120000 F    LCALL ?P0024
                                ; STATEMENT # 289

```



```

036C          THEN?44:
036C          22          RET
                   ; PROCEDURE ZONE (END)
                                ; STATEMENT # 290
036D          75816F      MOV     SP,#6FH
                                ; STATEMENT # 291
0370          758913      MOV     TMOD,#13H
                                ; STATEMENT # 292
0373          758840      MOV     TCON,#40H
                                ; STATEMENT # 293
0376          759800      MOV     SCON,#00H
                                ; STATEMENT # 294
0379          75B81F      MOV     IP,#1FH
                                ; STATEMENT # 295
037C          75A808      MOV     IE,#08H
                                ; STATEMENT # 296
037F          D2AF        SETB   EA
                                ; STATEMENT # 297
0381          C200    F    CLR     START
                                ; STATEMENT # 298
0383          750000    F    MOV     ZONE_I,#00H
                                ; STATEMENT # 299
0386          750000    F    MOV     DAC_COUNTER+0001H,#00H
0389          750000    F    MOV     DAC_COUNTER,#00H
                                ; STATEMENT # 300
038C          WHILE?49:
                                ; STATEMENT # 301
038C          WHILE?51:
038C          A200    F    MOV     C,TAG_0_INTR3
038E          B3      CPL     C
038F          4008      JC     WEND?52
                                ; STATEMENT # 302
0391          1100    F    ACALL  DAC_UPDATE
                                ; STATEMENT # 303
0393          1100    F    ACALL  ANALYSIS
                                ; STATEMENT # 304
0395          C200    F    CLR     TAG_0_INTR3
                                ; STATEMENT # 305
0397          80F3      SJMP   WHILE?51
0399          WEND?52:
                                ; STATEMENT # 306
0399          WHILE?53:
0399          A200    F    MOV     C,TAG_1_INTR3
039B          B3      CPL     C
039C          4008      JC     WEND?54
                                ; STATEMENT # 307
039E          1100    F    ACALL  SWITCH
                                ; STATEMENT # 308
03A0          1100    F    ACALL  TIME
                                ; STATEMENT # 309
03A2          C200    F    CLR     TAG_1_INTR3
                                ; STATEMENT # 310
03A4          80F3      SJMP   WHILE?53
03A6          WEND?54

```

```

                                ; STATEMENT # 311
03A6      WHILE?55:
03A6      A200  F      MOV    C,TAG_2_INTR3
03A8      B3    F      CPL    C
03A9      4006  F      JC     WEND?56
                                ; STATEMENT # 312
03AB      1100  F      ACALL  LITE
                                ; STATEMENT # 313
03AD      C200  F      CLR    TAG_2_INTR3
                                ; STATEMENT # 314
03AF      80F5  F      SJMP   WHILE?55
03B1      WEND?56:
                                ; STATEMENT # 315
03B1      WHILE?57:
03B1      A200  F      MOV    C,TAG_3_INTR3
03B3      B3    F      CPL    C
03B4      4006  F      JC     WEND?58
                                ; STATEMENT # 316
03B6      1100  F      ACALL  ZONE
                                ; STATEMENT # 317
03B8      C200  F      CLR    TAG_3_INTR3
                                ; STATEMENT # 318
03BA      80F5  F      SJMP   WHILE?57
03BC      WEND?58:
                                ; STATEMENT # 319
03BC      80CE  F      SJMP   WHILE?49
03BE      WEND?50:
                                ; STATEMENT # 320
                                ; PROCEDURE NASA00 (END)
03BE      CASE?JMPTBL?03BE:
                                ; JUMP TABLE FOR DO CASE
                                ; LEVEL 1
03BE      0100  F      AJMP   CASE?98
03C0      0100  F      AJMP   CASE?99
03C2      0100  F      AJMP   CASE?100
03C4      0100  F      AJMP   CASE?101
03C6      0100  F      AJMP   CASE?102
03C8      0100  F      AJMP   CASE?103
03CA      0100  F      AJMP   CASE?104
03CC      0100  F      AJMP   CASE?105
03CE      0100  F      AJMP   CASE?106
03D0      0100  F      AJMP   CASE?107
03D2      0100  F      AJMP   CASE?108
03D4      0100  F      AJMP   CASE?109

```

CROSS-REFERENCE LISTING

<u>DEFN</u>	<u>SPACE</u>	<u>SIZE</u>	<u>NAME</u>	<u>ATTRIBUTES AND REFERENCES</u>
111	CODE	158	ANALYSIS. . . .	PROCEDURE USING(0) STACK=02H 303
65	BIT	1	B0.	BIT MEMBER OF TEMPOR_BIT ; OFFSET=0
65	BIT	1	B1.	BIT MEMBER OF TEMPOR_BIT ; OFFSET=1
65	BIT	1	B2.	BIT MEMBER OF TEMPOR_BIT ; OFFSET=2
65	BIT	1	B3.	BIT MEMBER OF TEMPOR_BIT ; OFFSET=3
65	BIT	1	B4.	BIT MEMBER OF TEMPOR_BIT ; OFFSET=4 108
65	BIT	1	B5.	BIT MEMBER OF TEMPOR_BIT ; OFFSET=5 107
65	BIT	1	B6.	BIT MEMBER OF TEMPOR_BIT ; OFFSET=6 106
65	BIT	1	B7.	BIT MEMBER OF TEMPOR_BIT ; OFFSET=7 105
52	BIT	1	BLINK	BIT 82 208 254 262
24			DAC_COMP. . . .	BIT REGISTER AT(B4H) 89
25	DATA	2	DAC_COUNTER . .	WORD 92 93 94 97 98 99 102 119 128 192 194 196 198 200 202 204 299
29	CODE	2	DAC_MAX_COUNT .	WORD 92 93
88	CODE	104	DAC_UPDATE. . .	PROCEDURE USING(0) STACK=02H 302
2			DCL	LITERALLY 2 3 4 5 6 7 8 9 10 11 12 13 14 15 16 17 18 19 20 21 22 23 24 25 26 27 28 29 30 31 32 33 34 35 36 37 38 39 40 41 42 43 44 45 46 47 48 49 50 51 52 53 54 55 56 57 58 59 60 61 62 63 64 65
22			EA.	BIT REGISTER AT(AFH) 296
19			FAIL_LED. . . .	BIT REGISTER AT(A5H) 264 266 268 274
62	BIT	1	FAIL_ZONE_1 . .	BIT 120 178 266 268
64	BIT	1	FAIL_ZONE_3 . .	BIT

57	BIT	1	FINISH.	BIT	148 180 266 268
					169 176 186 261 265 267 271
					273
			HIGH.	BUILTIN	
					103
14			HI_RED_LED. . . .	BIT REGISTER AT(A0H)	
					212 219 226 233 240 247 254
15			HI_YEL_LED. . . .	BIT REGISTER AT(A1H)	
					211 218 225 232 239 246 253
43	DATA	1	HUND_MSEC	BYTE	
					73 75 77 79
8			IE.	BYTE REGISTER AT(A8H)	
					295
9			IP.	BYTE REGISTER AT(B8H)	
					294
190	CODE	356	LITE.	PROCEDURE USING(0) STACK=02H	
					312
			LOW	BUILTIN	
					104
18			LO_RED_LED. . . .	BIT REGISTER AT(A4H)	
					208 215 222 229 236 243 250
17			LO_YEL_LED. . . .	BIT REGISTER AT(A3H)	
					209 216 223 230 237 244 251
1	CODE	81	NASA00.	MODULE	
20			PASS_LED.	BIT REGISTER AT(A6H)	
					270 272 274
63	BIT	1	PASS_ZONE_2 . . .	BIT	
					129 179 268 272
30	CODE	2	PEAK_1.	WORD	
					119
31	CODE	2	PEAK_2.	WORD	
					128
32	CODE	2	PEAK_3.	WORD	
					147
26	DATA	2	PEAK_COUNTER. . .	WORD	
					136 140 141 144 145 147
3			PORT_0.	BYTE REGISTER AT(80H)	
					103
10			PORT_1_BIT_0. . .	BIT REGISTER AT(90H)	
					108
11			PORT_1_BIT_1. . .	BIT REGISTER AT(91H)	
					107
12			PORT_1_BIT_2. . .	BIT REGISTER AT(92H)	
					106
13			PORT_1_BIT_3. . .	BIT REGISTER AT(93H)	
					105
56	BIT	1	RUN	BIT	
					168 176 182 184 187 259 277
27	DATA	2	RUN_COUNTER . . .	WORD	
					181 279 281 283 285 287
21			RUN_LED	BIT REGISTER AT(A7H)	
					258 260 262
7			SCON.	BYTE REGISTER AT(98H)	

				293
44	DATA	1	SEC	BYTE 80 83 84
			SHL	BUILTIN 102
4			SP.	BYTE REGISTER AT(81H) 290
53	BIT	1	START	BIT 162 166 176 184 257 259 261 263 265 269 271 297
54	BIT	1	START_N	BIT 160 161 163
55	BIT	1	START_P	BIT 161 163
23			START_STOP_SW	BIT REGISTER AT(B3H) 160
159	CODE	24	SWITCH.	PROCEDURE USING(0) STACK=02H 307
48	BIT	1	TAG_0_INTR3	BIT 69 301 304
49	BIT	1	TAG-1-INTR3	BIT 74 306 309
50	BIT	1	TAG_2_INTR3	BIT 76 311 313
51	BIT	1	TAG_3_INTR3	BIT 81 315 317
5			TCON.	BYTE REGISTER AT(88H) 292
65	BITAD	1	TEMPOR_BIT.	STRUCTURE 66 105 106 107 108
66	DATA	1	TEMPOR_BIT_OVR.	BYTE AT(.TEMPOR_BIT) 104
28	DATA	2	TEMPOR_WORD	WORD 102 103 104
42	DATA	1	TEN_MSEC.	BYTE 68 70 72
67	CODE	52	TIC_COUNT	PROCEDURE USING(0) STACK=09H INTERRUPT(3)
165	CODE	76	TIME.	PROCEDURE USING(0) STACK=02H 308
38	CODE	2	TIME_1.	WORD 285
39	CODE	2	TIME_2.	WORD 283
40	CODE	2	TIME_3.	WORD 281
41	CODE	2	TIME_4.	WORD 279
6			TMOD.	BYTE REGISTER AT(89H) 291
47	BIT	1	UP_DNNOT_FLAG	BIT 89 90 138
45	DATA	1	WINDOW.	BYTE 191 193 195 197 199 201 203

33	CODE	2	WINDOW_1. . . .	WORD	205	206		
					194			
34	CODE	2	WINDOW_2. . . .	WORD	196			
35	CODE	2	WINDOW_3. . . .	WORD	198			
36	CODE	2	WINDOW_4. . . .	WORD	200			
37	CODE	2	WINDOW_5. . . .	WORD	202			
16			ZERO_GRN_LED. .	BIT REGISTER AT(A2H)	210	217	224	231 238 245 252
276	CODE	107	ZONE.	PROCEDURE USING(0) STACK=02H	316			
58	BIT	1	ZONE_1.	BIT	115	117	125	170
59	BIT	1	ZONE_2.	BIT	123	126	134	171
60	BIT	1	ZONE_3.	BIT	132	135	153	172
61	BIT	1	ZONE_4.	BIT	151	154	173	184
46	DATA	1	ZONE_I.	BYTE	112	174	280	282
					284	286	298	

WARNINGS:

3 IS HIGHEST USED INTERRUPT

MODULE INFORMATION:

(STATIC+OVERLAYABLE)

CODE SIZE	= 03D6H	982D	
CONSTANT SIZE	= 001AH	26D	
DIRECT VARIABLE SIZE	= 0DH+00H	13D+	0D
INDIRECT VARIABLE SIZE	= 00H+00H	0D+	0D
BIT SIZE	= 12H+00H	18D+	0D
BIT-ADDRESSABLE SIZE	= 01H+00H	1D+	0D
AUXILIARY VARIABLE SIZE	= 0000H	0D	
MAXIMUM STACK SIZE	= 0011H	17D	
REGISTER-BANK(S) USED:	=0		

409 LINES READ

0 PROGRAM ERROR(S)

END OF PL/M-51 COMPIATION

ISIS-II MCS-51 RELOCATOR AND LINKER, V3.0, INVOKED BY:
 RL51 :F0:NASA00.OBJ, :F0:PLM51.LIB TO NASA00.ABS PRINT(:LP:)

INPUT MODULES INCLUDED
 :F0:NASA00.OBJ(NASA00)
 :F0:PLM51.LIB(?P0008)
 :F0:PLM51.LIB(?P0024)
 :F0:PLM51.LIB(?P0026)
 :F0:PLM51.LIB(?P0032)
 :F0:PLM51.LIB(?PIV03)
 :F0:PLM51.LIB(?PIVOR)
 :F0:PLM51.LIB(?PIP03)

LINK MAP FOR :F0:NASA00.ABS(NASA00)

TYPE	BASE	LENGTH	RELOCATION	SEGMENT NAME
REG	0000H	0008H		"REG BANK 0"
DATA	0008H	000DH	UNIT	?NASA00?DT
	0015H	000BH		*** GAP ***
DATA	0020H	0001H	BIT_ADDR	?NASA00?BA
BIT	0021H	0002H.2	UNIT	?NASA00?BI
	0023H.2	0000H.6		*** GAP ***
IDATA	0024H	0001H	UNIT	?STACK
CODE	0000H	0003H	ABSOLUTE	
CODE	0003H	000EH	UNIT	?P0032S
CODE	0011H	0009H	UNIT	?P0008S
	001AH	0001H		*** GAP ***
CODE	001BH	0003H	ABSOLUTE	
CODE	001EH	03D6H	INBLOCK	?NASA00?PR
CODE	03F4H	001BH	UNIT	?PIP03S
CODE	040FH	001AH	UNIT	?NASA00?CO
CODE	0429H	0009H	UNIT	?PIVORS
CODE	0432H	0008H	UNIT	?P0024S
CODE	043AH	0008H	UNIT	?P0026S

SYMBOL TABLE FOR :F0:NASA00.ABS(NASA00)

VALUE	TYPE	NAME
-----	MODULE	NASA00
C:038BH	SYMBOL	NASA00
D:0080H	SYMBOL	PORT_0
D:0081H	SYMBOL	SP
D:0088H	SYMBOL	TCON
D:0089H	SYMBOL	TMOD
D:0098H	SYMBOL	SCON

D:00A8H	SYMBOL	IE
D:00B8H	SYMBOL	IP
B:0090H	SYMBOL	PORT_1_BIT_0
B:0090H.1	SYMBOL	PORT_1_BIT_1
B:0090H.2	SYMBOL	PORT_1_BIT_2
B:0090H.3	SYMBOL	PORT_1_BIT_3
B:00A0H	SYMBOL	HI_RED_LED
B:00A0H.1	SYMBOL	HI_YEL_LED
B:00A0H.2	SYMBOL	ZERO_GRN_LED
B:00A0H.3	SYMBOL	LO_YEL_LED
B:00A0H.4	SYMBOL	LO_RED_LED
B:00A0H.5	SYMBOL	FAIL_LED
B:00A0H.6	SYMBOL	PASS_LED
B:00A0H.7	SYMBOL	RUN_LED
B:00A8H.7	SYMBOL	EA
B:00B0H.3	SYMBOL	START_STOP_SW
B:00B0H.4	SYMBOL	DAC_COMP
D:0008H	SYMBOL	DAC_COUNTER
D:000AH	SYMBOL	PEAK_COUNTER
D:000CH	SYMBOL	RUN_COUNTER
D:000EH	SYMBOL	TEMPOR_WORD
C:040FH	SYMBOL	DAC_MAX_COUNT
C:0411H	SYMBOL	PEAK_1
C:0413H	SYMBOL	PEAK_2
C:0415H	SYMBOL	PEAK_3
C:0417H	SYMBOL	WINDOW_1
C:0419H	SYMBOL	WINDOW_2
C:041BH	SYMBOL	WINDOW_3
C:041DH	SYMBOL	WINDOW_4
C:041FH	SYMBOL	WINDOW_5
C:0421H	SYMBOL	TIME_1
C:0423H	SYMBOL	TIME_2
C:0425H	SYMBOL	TIME_3
C:0427H	SYMBOL	TIME_4
D:0010H	SYMBOL	TEN_MSEC
D:0011H	SYMBOL	HUND_MSEC
D:0012H	SYMBOL	SEC
D:0013H	SYMBOL	WINDOW
D:0014H	SYMBOL	ZONE_I
B:0021H	SYMBOL	UP_DNNOT_FLAG
B:0021H.1	SYMBOL	TAG_0_INTR3
B:0021H.2	SYMBOL	TAG_1_INTR3
B:0021H.3	SYMBOL	TAG_2_INTR3
B:0021H.4	SYMBOL	TAG_3_INTR3
B:0021H.5	SYMBOL	BLINK
B:0021H.6	SYMBOL	START
B:0021H.7	SYMBOL	START_N
B:0022H	SYMBOL	START_P
B:0022H.1	SYMBOL	RUN
B:0022H.2	SYMBOL	FINISH
B:0022H.3	SYMBOL	ZONE_1
B:0022H.4	SYMBOL	ZONE_2
B:0022H.5	SYMBOL	ZONE_3
B:0022H.6	SYMBOL	ZONE_4

B:0022H.7	SYMBOL	FAIL_ZONE_1
B:0023H	SYMBOL	PASS_ZONE_2
B:0023H.1	SYMBOL	FAIL_ZONE_3
D:0020H	SYMBOL	TEMPOR_BIT
D:0020H	SYMBOL	TEMPOR_BIT_OVR
C:001EH	SYMBOL	TIC_COUNT
-----	PROC	TIC_COUNT
-----	ENDPROC	TIC_COUNT
C:0052H	SYMBOL	DAC_UPDATE
-----	PROC	DAC_UPDATE
-----	ENDPROC	DAC_UPDATE
C:00BAH	SYMBOL	ANALYSIS
-----	PROC	ANALYSIS
-----	ENDPROC	ANALYSIS
C:0158H	SYMBOL	SWITCH
-----	PROC	SWITCH
-----	ENDPROC	SWITCH
C:0170H	SYMBOL	TIME
-----	PROC	TIME
-----	ENDPROC	TIME
C:01BCH	SYMBOL	LITE
-----	PROC	LITE
-----	ENDPROC	LITE
C:0320H	SYMBOL	ZONE
-----	PROC	ZONE
-----	ENDPROC	ZONE
C:038BH	LINE#	1
C:001EH	LINE#	67
C:001EH	LINE#	68
C:0020H	LINE#	69
C:0022H	LINE#	70
C:0027H	LINE#	72
C:002AH	LINE#	73
C:002CH	LINE#	74
C:002EH	LINE#	75
C:0039H	LINE#	76
C:003BH	LINE#	77
C:0040H	LINE#	79
C:0043H	LINE#	80
C:0045H	LINE#	81
C:0047H	LINE#	82
C:0049H	LINE#	83
C:004EH	LINE#	84
C:0051H	LINE#	85
C:0051H	LINE#	86
C:0051H	LINE#	87
C:0052H	LINE#	88
C:0052H	LINE#	89
C:0056H	LINE#	90
C:005BH	LINE#	92
C:0070H	LINE#	93
C:0078H	LINE#	94
C:007FH	LINE#	95
C:007FH	LINE#	96

C:0081H	LINE#	97
C:0087H	LINE#	98
C:008DH	LINE#	99
C:0094H	LINE#	100
C:0094H	LINE#	101
C:0094H	LINE#	102
C:00A1H	LINE#	103
C:00A5H	LINE#	104
C:00A9H	LINE#	105
C:00ADH	LINE#	106
C:00B1H	LINE#	107
C:00B5H	LINE#	108
C:00B9H	LINE#	110
C:00BAH	LINE#	111
C:00BAH	LINE#	112
C:00C2H	LINE#	113
C:00C4H	LINE#	115
C:00C8H	LINE#	117
C:00CAH	LINE#	119
C:00DFH	LINE#	120
C:00E1H	LINE#	121
C:00E3H	LINE#	123
C:00E7H	LINE#	125
C:00E9H	LINE#	126
C:00EBH	LINE#	128
C:0100H	LINE#	129
C:0102H	LINE#	130
C:0104H	LINE#	132
C:0108H	LINE#	134
C:010AH	LINE#	135
C:010CH	LINE#	136
C:0112H	LINE#	138
C:0117H	LINE#	140
C:0124H	LINE#	141
C:0129H	LINE#	142
C:0129H	LINE#	143
C:012BH	LINE#	144
C:0131H	LINE#	145
C:0136H	LINE#	146
C:0136H	LINE#	147
C:014BH	LINE#	148
C:014DH	LINE#	149
C:014FH	LINE#	151
C:0153H	LINE#	153
C:0155H	LINE#	154
C:0157H	LINE#	156
C:0157H	LINE#	157
C:0157H	LINE#	158
C:0158H	LINE#	159
C:0158H	LINE#	160
C:015CH	LINE#	161
C:0169H	LINE#	162
C:016BH	LINE#	163
C:016FH	LINE#	164

C:0170H	LINE#	165
C:0170H	LINE#	166
C:0174H	LINE#	168
C:0176H	LINE#	169
C:0178H	LINE#	170
C:017AH	LINE#	171
C:017CH	LINE#	172
C:017EH	LINE#	173
C:0180H	LINE#	174
C:0183H	LINE#	176
C:0195H	LINE#	178
C:0197H	LINE#	179
C:0199H	LINE#	180
C:019BH	LINE#	181
C:01A1H	LINE#	182
C:01A3H	LINE#	184
C:01B7H	LINE#	186
C:01B9H	LINE#	187
C:01BBH	LINE#	189
C:01BCH	LINE#	190
C:01BCH	LINE#	191
C:01BFH	LINE#	192
C:01C5H	LINE#	193
C:01C7H	LINE#	194
C:01DCH	LINE#	195
C:01DEH	LINE#	196
C:01F3H	LINE#	197
C:01F5H	LINE#	198
C:020AH	LINE#	199
C:020CH	LINE#	200
C:0221H	LINE#	201
C:0223H	LINE#	202
C:0238H	LINE#	203
C:023AH	LINE#	204
C:0246H	LINE#	205
C:0249H	LINE#	206
C:0251H	LINE#	208
C:0255H	LINE#	209
C:0257H	LINE#	210
C:0259H	LINE#	211
C:025BH	LINE#	212
C:025DH	LINE#	213
C:025FH	LINE#	215
C:0261H	LINE#	216
C:0263H	LINE#	217
C:0265H	LINE#	218
C:0267H	LINE#	219
C:0269H	LINE#	220
C:026BH	LINE#	222
C:026DH	LINE#	223
C:026FH	LINE#	224
C:0271H	LINE#	225
C:0273H	LINE#	226
C:0275H	LINE#	227

C:0277H	LINE#	229
C:0279H	LINE#	230
C:027BH	LINE#	231
C:027DH	LINE#	232
C:027FH	LINE#	233
C:0281H	LINE#	234
C:0283H	LINE#	236
C:0285H	LINE#	237
C:0287H	LINE#	238
C:0289H	LINE#	239
C:028BH	LINE#	240
C:028DH	LINE#	241
C:028FH	LINE#	243
C:0291H	LINE#	244
C:0293H	LINE#	245
C:0295H	LINE#	246
C:0297H	LINE#	247
C:0299H	LINE#	248
C:029BH	LINE#	250
C:029DH	LINE#	251
C:029FH	LINE#	252
C:02A1H	LINE#	253
C:02A3H	LINE#	254
C:02A7H	LINE#	256
C:02A7H	LINE#	257
C:02ABH	LINE#	258
C:02ADH	LINE#	259
C:02BBH	LINE#	260
C:02BDH	LINE#	261
C:02CBH	LINE#	262
C:02CFH	LINE#	263
C:02D3H	LINE#	264
C:02D5H	LINE#	265
C:02E2H	LINE#	266
C:02EBH	LINE#	267
C:02EDH	LINE#	268
C:02FEH	LINE#	269
C:0302H	LINE#	270
C:0304H	LINE#	271
C:0311H	LINE#	272
C:0315H	LINE#	273
C:031AH	LINE#	274
C:031FH	LINE#	275
C:0320H	LINE#	276
C:0320H	LINE#	277
C:0325H	LINE#	279
C:033AH	LINE#	280
C:033DH	LINE#	281
C:0352H	LINE#	282
C:0355H	LINE#	283
C:036AH	LINE#	284
C:036DH	LINE#	285
C:0382H	LINE#	286
C:0385H	LINE#	287

C:038AH	LINE#	289
C:038BH	LINE#	290
C:038EH	LINE#	291
C:0391H	LINE#	292
C:0394H	LINE#	293
C:0397H	LINE#	294
C:039AH	LINE#	295
C:039DH	LINE#	296
C:039FH	LINE#	297
C:03A1H	LINE#	298
C:03A4H	LINE#	299
C:03AAH	LINE#	300
C:03AAH	LINE#	301
C:03AFH	LINE#	302
C:03B1H	LINE#	303
C:03B3H	LINE#	304
C:03B5H	LINE#	305
C:03B7H	LINE#	306
C:03BCH	LINE#	307
C:03BEH	LINE#	308
C:03C0H	LINE#	309
C:03C2H	LINE#	310
C:03C4H	LINE#	311
C:03C9H	LINE#	312
C:03CBH	LINE#	313
C:03CDH	LINE#	314
C:03CFH	LINE#	315
C:03D4H	LINE#	316
C:03D6H	LINE#	317
C:03D8H	LINE#	318
C:03DAH	LINE#	319
C:03DCH	LINE#	320
-----	ENDMOD	NASA00

APPENDIX III

INSTRUMENT CONDITIONS

GOW-MAC INSTRUMENT CO.
BRIDGEWATER, NEW JERSEY
DATE _____

INSTR. MODEL 69-550
DETECTOR TCD
COLUMN SIZE 10' X 1/8' SS
LIQUID PHASE _____
SUPPORT _____
CARRIER GAS HELIUM
CARRIER FLOW 30ml/MIN
H2 FLOW _____
AIR FLOW _____
RECORDER FS:lmv

SAMPLE JP-5 IN AVGAS
SOLVENT AVGAS
SAMPLE SIZE 1 MICROLITER
TEMP:
COLUMN 250 DEG.C
INJ. PORT 250 DEG.C
DETECTOR 300 DEG.C
BRIDGE CURRENT _____
ATTENUATION 1
CHART SPEED 1cm/MIN

APPENDIX IV

CHANNEL A INJECT 10/14/85 18:08:11

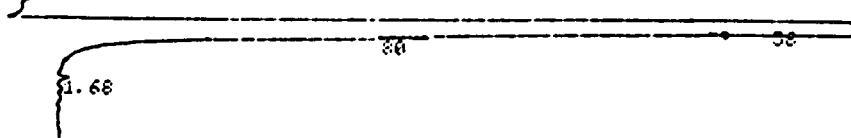

10/14/85 18:08:11 CH= "A" PS= 1.

FILE	METHOD	Q.	RUN	INDEX
1.		0.	5	5
PEAK#	AREA%	RT	AREA	GC
1	81.968	0.46	2678492	02
2	17.885	0.58	584419	02
3	0.146	0.8	4757	03
4	0.002	1.68	63	01
TOTAL	100.		3267731	

0.5

0% JET FUEL; PASS LED ON

CHANNEL A INJECT 10/18/85 14:30:58

170 vol FAIL

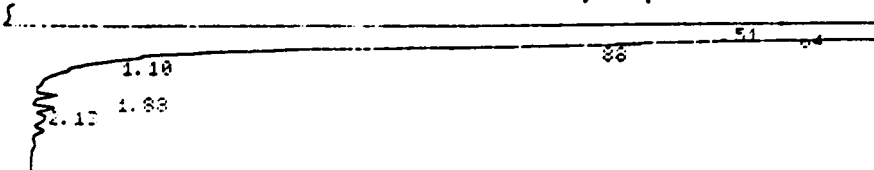

10/18/85 14:30:58 CH= "A" PS= 1.

FILE	METHOD	Q.	RUN	INDEX
1.		0.	3	3
PEAK#	AREA%	RT	AREA	GC
1	81.927	0.51	2999017	02
2	18.85	0.64	668739	08
3	0.012	0.86	451	05
4	0.001	1.1	31	05
5	0.006	1.88	206	01
6	0.004	2.12	161	01
TOTAL	100.		3660605	

170 JET FUEL; FAIL LED ON

CHANNEL A INJECT 10/18/85 14:37:40

50% vol FAIL

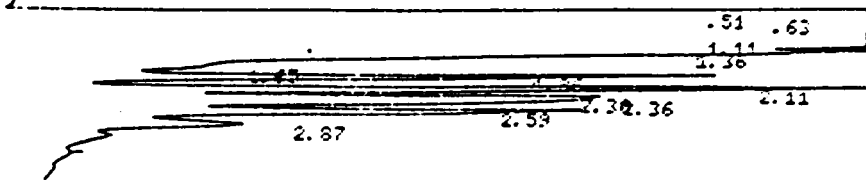

10/18/85 14:37:40 CH= "A" PS= 1.

FILE	METHOD	Q.	RUN	INDEX
1.		0.	4	4
PEAK#	AREA%	RT	AREA	GC
1	40.846	0.51	1553958	02
2	57.959	0.63	2205014	08
3	0.058	1.11	2202	05
4	0.062	1.36	2373	05
5	0.002	1.68	80	05
6	0.169	1.86	6413	05
7	0.248	2.11	9417	05
8	0.154	2.36	5853	06
9	0.188	2.36	7162	06
10	0.208	2.59	7906	06
11	0.106	2.87	4029	07
TOTAL	100.		3804487	

50% JET FUEL; FAIL LED ON

APPENDIX IV Sample Tests

ORIGINAL PAGE IS OF POOR QUALITY

1. Report No. NASA TP-2803		2. Government Accession No.		3. Recipient's Catalog No.	
4. Title and Subtitle Investigation of the Misfueling of Reciprocating Piston Aircraft Engines				5. Report Date March 1988	
				6. Performing Organization Code 824.2	
7. Author(s) J. Holland Scott, Jr.				8. Performing Organization Report No.	
				10. Work Unit No.	
9. Performing Organization Name and Address NASA Goddard Space Flight Center Wallops Flight Facility Wallops Island, VA 23337				11. Contract or Grant No.	
				13. Type of Report and Period Covered Technical Paper	
12. Sponsoring Agency Name and Address National Aeronautics and Space Administration Washington, DC 20546				14. Sponsoring Agency Code	
15. Supplementary Notes					
16. Abstract The Aircraft Misfueling Detection Project was developed by the Goddard Space Flight Center/Wallops Flight Facility at Wallops Island, Virginia. Its purpose was to investigate the misfueling of reciprocating piston aircraft engines by the inadvertent introduction of jet fuel in lieu of or as a contaminant of aviation gasoline (avgas). The final objective was the development of a device(s) that will satisfactorily detect misfueling and provide pilots with sufficient warning to avoid injury, fatality, or equipment damage. Two devices have been developed and successfully tested: one, a small contamination detection kit, for use by the pilot, and a second, more sensitive, modified gas chromatograph for use by the fixed-base operator (FBO). The gas chromatograph, in addition to providing excellent quality control of the FBO's fuel handling operation, is a very good back-up for the detection kit in the event it produces positive results. Design parameters were developed to the extent that they may be easily applied to commercial production by the aircraft industry.					
17. Key Words (Suggested by Author(s)) General Aviation Jet Fuel Aircraft Detonation Aircraft Engines Evaporation Misfueling Detonable Gas Mixtures Avgas Gas Chromatograph			18. Distribution Statement Unclassified - unlimited Subject Category 03		
19. Security Classif. (of this report) Unclassified		20. Security Classif. (of this page) Unclassified		21. No. of pages 79	22. Price A05