

---

# In-Flight Rain Damage Tests of the Shuttle Thermal Protection System

---

Robert R. Meyer, Jr. and Jack Barneburg

---

(NASA-TM-100438) IN-FLIGHT RAIN DAMAGE  
TESTS OF THE SHUTTLE THERMAL PROTECTION  
SYSTEM (NASA) 16 p CSCL 22B

N88-21241

Unclas  
G3/18 0137317

May 1988



National Aeronautics and  
Space Administration

---

# In-Flight Rain Damage Tests of the Shuttle Thermal Protection System

---

Robert R. Meyer, Jr.  
Ames Research Center, Dryden Flight Research Facility, Edwards, California  
Jack Barneburg  
Johnson Space Center, Houston, Texas

1988



National Aeronautics and  
Space Administration

**Ames Research Center**

Dryden Flight Research Facility  
Edwards, California 93523-5000

# IN-FLIGHT RAIN DAMAGE TESTS OF THE SHUTTLE THERMAL PROTECTION SYSTEM

Robert R. Meyer, Jr.  
NASA Ames Research Center  
Dryden Flight Research Facility  
Edwards, California

and

Jack Barneburg  
NASA Johnson Space Center  
Houston, Texas

## Abstract

NASA conducted in-flight rain damage tests of the Shuttle thermal protection system (TPS). The majority of the tests were conducted on an F-104 aircraft at the Dryden Flight Research Facility of NASA's Ames Research Center, although some tests were conducted by the National Oceanographic and Atmospheric Administration (NOAA) on a WP-3D aircraft off the eastern coast of southern Florida. The thermal protection system components tested included LI900 and LI2200 tiles, advanced flexible reusable surface insulation (AFRSI), reinforced carbon carbon (RCC), and an advanced tuff tile. The objective of the test was to define the damage threshold of various thermal protection materials during flight through rain. The test hardware, test technique, and results from both the F-104 and WP-3D aircraft are described. Results have shown that damage can occur to the Shuttle TPS during flight in rain.

## Introduction

Space Shuttle launch and landing operations at present are restricted due to weather constraints. One of the constraints is potential damage to the orbiters' thermal protection system (TPS) while flying through rain or clouds (Fig. 1). Launch TPS damage could compromise safety during entry, and launch or landing TPS damage would require postflight TPS repair, resulting in schedule and cost impacts. These weather-related restrictions are of concern primarily for meteorological conditions commonly experienced at the Kennedy Space Center (KSC). Consequently, NASA is engaged in a flight test program to define the Shuttle TPS damage threshold for flight through rain or clouds in terms of speed, droplet size, and other weather related environmental factors.

The test program was the primary responsibility of the NASA Johnson Space Center (JSC). NASA JSC re-

quested the Dryden Flight Research Facility of NASA's Ames Research Center (Ames-Dryden) at Edwards, California to perform the majority of the tests on an instrumented NASA-Lockheed F-104 aircraft in both a USAF KC-135 water spray tanker generated moisture environment and actual cloud-rain conditions. NASA JSC has also requested the National Oceanographic and Atmospheric Administration (NOAA) Office of Flight Operations in Miami, Florida to conduct tests on an instrumented NOAA-Lockheed WP-3D aircraft in a natural cloud-rain environment. Both aircraft were equipped with raindrop-size-measuring instruments. Distinct features of the aircraft are cloud radars carried by the WP-3D and the greater speed and altitude capability of the F-104 airplane.

The test hardware, test techniques, and results from both aircraft, with primary emphasis on the NASA Ames-Dryden F-104 activity, are described in this report. Limited comparisons have been made to previous ground-based test results. In-flight rain damage of an advanced TPS tile, hereafter referred to as a "tuff" tile, has also been included.

## Description of Test Aircraft and Test Hardware

### F-104 Aircraft

Shuttle TPS coupons were mounted on the nose-cap of a flight test fixture (FTF) carried beneath an instrumented F-104 aircraft (Fig. 2). The F-104 airplane was capable of test airspeeds of 250 to 550 knots indicated airspeed (KIAS) or 1.5 Mach with this test hardware installed.

The test coupons were composed of 2 by 6 in. pieces of TPS material mounted "fixed" at 90°, 60°, 30°, and 15° and an 8 by 8 in. piece mounted at 0° to the free-stream flow (Fig. 3). Although not shown in Fig. 3, two 30° mounting locations were available, one on the left side (as shown in the figure) and one (not shown) on

the right side of the fixture. The tile test coupons were flush with the surrounding test fixture surface when mounted in the test fixture.

Instrumentation consisted primarily of a particle measurement probe, airdata probes, and video camera (Fig. 2). The particle measurement probe optically detected and measured particle size, distribution, and concentration. The device used on the F-104 aircraft was a one-dimensional optical array droplet probe (model PMS OAP-260Y) capable of detecting particles between 0.050 to 3.000 mm with a resolution of 0.050 mm. Airdata were determined from two sources — one was a probe mounted on the lower leading edge of the TPS flight test fixture, and the other was the pilot's standard airspeed system. Two video cameras were used to determine when damage occurred to the various TPS test coupons. One video camera was mounted on the lower forward fuselage providing aft viewing of the forward portion of the flight test fixture. This camera provided coverage of the 90°, 60°, and two 30° TPS test samples. Another video camera was mounted on a left wing pylon and provided a view of the left side of the flight test fixture. This camera primarily viewed the 15° and 0° TPS test samples.

#### WP-3D Aircraft

Shuttle TPS test coupons were mounted on a pylon underneath the right wing of the NOAA WP-3D aircraft (Fig. 4). The WP-3D weather research aircraft obtained rain impact data for airspeeds between 180 and 260 KIAS.

Test samples were mounted on two movable doors contained within both the left and right sides of the test fixture, for a total of four doors (Fig. 5). These doors could be opened or closed in-flight to angles of 0°, 15°, 30°, 45°, or 60° to the free-stream flow.

Instrumentation consisted of onboard weather radars, particle size measuring devices, and video cameras. The weather radars consisted of a C-band 5 cm belly-mounted radar, an X-band 3 cm tail-mounted Doppler radar, and a C-band nose-mounted navigation weather radar. There were three particle measurement devices mounted under the left wing of the aircraft (Fig. 6): a one-dimensional forward scattering spectrometer probe that detects particle sizes between 0.03 to 0.45 mm, a two-dimensional optical array cloud droplet imaging probe that detects particle sizes between 0.05 to 1.6 mm, and a two-dimensional optical array precipitation imaging probe that detects particle sizes between 0.2 to 6.4 mm. Each of the three probes recorded data during the flights, but only the latter two were used for data reduction during these flights. A video camera was mounted forward of the test fixture (Fig. 5b) and recorded test article damage during the flights. Airdata were determined from an airdata probe mounted on the left wing.

#### TPS Test Articles

Standard LI900 and LI2200 tiles, reinforced carbon carbon (RCC) and advanced flexible reusable surface insulation (AFRSI) quilt materials<sup>1-4</sup> were flown during these tests. On one F-104 flight, a toughened uni-piece fibrous insulation tile,<sup>5</sup> or a so-called "tufi" tile was flown.

The F-104 tile test coupons consisted primarily of 2 by 6 in. pieces cut from 6 by 6 in. tiles. The 2 by 6 in. LI900 test coupons were cut from flight worthy 6 by 6 in. tiles, saving the two edge pieces and discarding the centerpiece. The cut edge was treated using a standard TPS repair, and the cut edge was installed facing aft in the test fixture. The 2 by 6 in. LI2200 and tufi tile were specifically constructed for these tests. The tiles were bonded to an aluminum plate using a strain isolation pad (standard shuttle installation) mechanically attached to the test fixture. Examples of LI900 and LI2200 tiles prior to testing are shown in Fig. 7.

The WP-3D test coupons consisted of 6 by 6 in. LI900 and LI2200 tiles and flexible reusable surface insulation (FRSI) and AFRSI bonded in a similar manner to the F-104 test coupons. Only results from the LI900 tiles are presented in this report.

#### Test Approach

Tests were conducted in a natural rain and clouds environment and attempted in an artificially generated rain environment from a USAF KC-135 water spray tanker.

#### Spray Tanker

Tests in moisture generated by a USAF KC-135 water spray tanker with an uncalibrated rain nozzle were attempted using only the F-104 aircraft at speeds from 250 to 350 KIAS. The tanker was flown at predetermined speeds, altitudes, and water flow rates. Water spray from a nozzle was directed at the tile test articles mounted beneath the F-104 aircraft (Fig. 8).

#### Natural Rain

Tests were conducted using both the F-104 and WP-3D aircraft in natural rain, although different techniques were used finding and entering the rain.

The F-104 tests were conducted within Edwards Air Force Base, California test areas at speeds from 250 to 550 KIAS and altitudes generally between 4000 to 8000 ft. The tests were normally conducted in the winter months and rain was generally encountered on the leeward side of the southern Sierra Nevada mountains.

Rain was located visually by the aircraft pilot and a racetrack pattern was established (Fig. 9) where the aircraft was flown through the rain at increasing speeds, generally at 25 KIAS increments. The racetrack pattern was flown until the desired TPS coupon

failures had occurred or a maximum test speed of 550 KIAS was achieved.

The WP-3D tests were conducted off the eastern coast of southern Florida. The tests were normally conducted in maritime tropical rain at speeds from 180 to 260 knots. The altitudes were generally just below the base of the rain cloud between 1500 and 2000 ft. Some tests were conducted through the middle and top of the rain cloud between 5000 and 10,000 ft.

Rain was located using the previously described onboard weather radars. The TPS coupons were extended at the previously described angles from the test fixture before entering the rain areas. Once a particular test coupon failed, it was retracted into the test fixture, and the other coupons continued to be exposed.

For both the F-104 and WP-3D aircraft, the TPS failures were noted using the onboard video cameras and documented as a function of particle size and velocity.

### Natural Clouds

Limited tests were conducted in low-altitude cumulus and high-cirrus clouds at Edwards AFB using only the F-104 aircraft at speeds up to 550 KIAS or 1.5 Mach, respectively.

## Test Results and Discussion

In-flight evaluation of the F-104 particle measurement probe, results of flight through natural rain and clouds with various TPS, and flight behind the USAF KC-135 water spray tanker are discussed.

### Particle Measurement Probe Evaluation

A major concern at the onset of this test program was the accuracy of the particle measurement probe in a high-speed flight environment, particularly since the probe was used at speeds higher than it was designed for. Evaluation of the probe was made for two environments with the F-104 aircraft. One evaluation test was conducted in natural rain and the other was in natural clouds.

After natural rain flights, TPS tiles eroded by rain often exhibited small holes in the soft substrate of the tile (Fig. 10). A method of evaluation was to correlate the resulting postflight tile substrate hole diameter with particle diameters obtained from the particle measurements probe at the time the damage occurred. The maximum hole diameter measured from the tile in Fig. 10 (postflight) was between 2.5 to 3.0 mm, compared to a maximum recorded particle diameter of 2.7 mm measured in real time by the particle measurement probe. This close agreement between the two methods increased the confidence that the particle measurement probe provided accurate results in a natural rain environment.

During flight in natural clouds, a comparison of a different sort was made. In this case, a series of calibration runs were made at increasing speeds through a nonprecipitating cloud that did not change visually. The evaluation in this case was to compare the output from the particle measurement probe at different speeds in a relatively constant cloud. A comparison of the raw count histogram from 275 and 550 KIAS runs through the cloud is shown in Fig. 11. The figure clearly shows a marked difference in the distribution and maximum particle size at the two speeds through the cloud. For example, at 275 KIAS the maximum particle size was about 0.7 mm, while at 550 KIAS the maximum indicated particle size was about 2.0 mm. These differences were believed to be much too large to be accounted for by changes in the cloud character with time and are thought to be attributable to problems associated with the probe's ability to accurately measure or process the extremely large number of particles encountered in clouds at high speeds. Consequently, particle measurement probe results from nonprecipitating clouds will not be presented in this report.

### Natural Rain

Flights through rain with both the F-104 and WP-3D aircraft resulted in damage and erosion to the TPS tiles. The damage to the TPS tiles started as "star" cracks in the black face coat of the tile and were normally not visible from the onboard video cameras but were sometimes noted during postflight inspection. The next definable level of damage was scarring of the tiles, where pits were formed in the TPS tile, penetrating the black face coat and exposing the white substrate of the tile. The last definable level of damage was major erosion of the tile substrate. Examples of these three stages of damage are shown in Fig. 12. The pitting and erosion of the tiles were normally visible in real time with the onboard video cameras. In this paper, tile damage threshold is defined as pitting of the surface.

The tile damage data are plotted in terms of velocity and drop diameter on Figs. 13 to 16, which have lines of constant kinetic energy shown for reference in later discussions. The 0.006 ft-lb energy line represents an empirically derived surface fracture energy for failure from an impact with a solid, such as a metal sphere, at 90° to the surface. The 0.06 ft-lb energy line is shown for reference.

Figures 13 and 14 present results of the LI900 and LI2200 tile flights through rain. The figures present the velocity and maximum raindrop diameter (detected by the particle measurement probe) for damage threshold or pitting of the surface. The F-104 aircraft results are summarized in Table 1, and the WP-3D results are summarized in Table 2.

For the WP-3D results, summarized in Table 2, data are presented for both failure or pitting as well as no occurrence of damage or no failure. The no failure data were presented because of uncertainties in defining the damage threshold for the WP-3D data.

The WP-3D results were obtained from a maritime tropical rain, where the in-flight rain intensity usually changed rapidly and the tiles often failed in an overwhelming manner, resulting in damage from a broad range of drop diameters extending well beyond the damage threshold. The F-104 results were obtained in a relatively stable environment where raindrop diameter did not tend to change rapidly. Consequently, the determination of pitting or damage threshold from the F-104 tests was obtained with a high degree of confidence, but the WP-3D results were somewhat uncertain. An indicator of this uncertainty is the difference between the no failure and failure columns of Table 2. For example, the used LI900 tile at 30° and 417 fps had no failure at 2.6 mm but failed at 2.8 mm, indicating a high degree of confidence in determination of the failure threshold. Another example is the new LI2200 tile at 60° and 378 fps, which had no failures at 2.4 and 3.0 mm, but failed at 4.6 and 5.6 mm, respectively, indicating a low degree of confidence because of the large difference in the no failure and failure particle diameters.

For the LI900 tile, the damage threshold data indicate a higher failure energy for the large particle sizes and a lower failure energy for the small particle sizes relative to the 0.06 ft-lb reference energy line (the slope of the plotted failures is flatter than the 0.06 ft-lb reference energy line). This is particularly noticeable for the high incidence angles (Figs. 13c and 13d). The same trend seems to exist for the LI2200 tile, for an incidence angle of 60° (Fig. 14a); however, the change in energy with particle size does not seem as definite as with the LI900 tiles, especially for the 90° incidence angle (Fig. 14b). It is unclear whether this trend is due to the tile failure mechanism or lack of data points to accurately define the trend.

Figures 13b and 13c include data for tiles that were first flown or used on the orbiter Columbia for five missions (five launches and entries) before being exposed to rain during F-104 aircraft flights. In both cases, the used tile failure data tended to occur at the low edge of the scatter in the data, indicating that the used tiles fail at a slightly lower energy than new or unused tiles.

The LI900 tile failure data for the 90° test coupon from both flight and ground tests, along with the previously discussed lines of constant energy, are shown in Fig. 15. Also included on the figure are published and unpublished single impact water drop failure data obtained from ground tests. The flight test results indicate for a particle > 2.0 mm a damage threshold energy > 0.06 ft-lb, or a factor of ten more energy required to

fail the tile than the 0.006 ft-lb surface fracture criteria. Extrapolation of the flight data to smaller particle sizes, < 1.0 mm, suggests that the test data may approach the 0.006 ft-lb surface fracture criteria. This is the same data trend discussed earlier (Figs. 13c, 13d, and 14a). The flight test data also indicate considerably higher failure energies than the single impact water drop ground tests.

The differences in damage threshold energy with particle size between the 0.006 ft-lb surface fracture and the flight test results are attributed to changes in the kinetic energy being transferred during impact with particle size and speed. The 0.006 ft-lb surface fracture is based on results from the kinetic energy of a solid-solid impact (solid particle impacting a solid surface at 90° to the surface). The flight and ground test water droplet impact damage threshold results are from a liquid-solid impact (liquid particle impacting a solid surface). The data presented in Fig. 15 indicate that the kinetic energy transfer of the large particle-slow-speed water drop impact is much less than a solid-solid impact, while the small particle size-high-speed water drop impact approach the solid-solid impact.

The differences between the single impact water drop ground tests and flight tests are not understood at this time.

The LI2200 tile damage threshold data at 90° and one data point from the so-called tuff tile<sup>5</sup> are shown in Fig. 16. Also included are published<sup>6</sup> and unpublished single impact water drop failure data obtained from ground tests. The data for the LI2200 tile indicate closer agreement between the unpublished ground and flight test results than for the LI900 tile results, although the published ground tests are still considerably lower.

The tuff tile shows a significant improvement over the existing LI2200 tile. The damage to the tuff tile was different than the previously described damage to LI900 and LI2200 tile. The face coat on the tuff tile is considerably thicker than either the LI900 or the LI2200 tile. The data point for the tuff tile represents pitting of the face coat only and does not represent exposure of the white substrate under the face coat.

No damage occurred to either the TPS tile or quilt materials mounted at 0° to the free-stream flow, or to the RCC material mounted 90° to the free-stream flow. The maximum condition that the respective materials were exposed to without damage is shown in Table 3.

### Natural Clouds

No damage occurred to any TPS (tile or quilt) materials during flight in nonprecipitating clouds. This included thick high-cirrus clouds at speeds up to 1.5 Mach number or cumulus clouds at speeds up to 550 KIAS. The high-cirrus clouds are believed to have

been composed of small liquid drops rather than large ice crystals.

### Spray Tanker

Tests were conducted behind the USAF KC-135 spray tanker using the rain nozzle at a maximum flow rate of 55 gal/min and 350 KIAS. For this test LI900 TPS tiles were installed in all positions of the test fixture. No TPS damage occurred from these flights. It was believed that the spray tanker did not correctly simulate natural rain impact damage, and the technique was discontinued.

The visual observations from the flight crews during the spray tanker tests indicated that the spray emitted by the tanker rain nozzle was more of a mist than rain. The observations were confirmed by the particle measurement probe output from a typical spray tanker test. The particle distribution was similar to a cloud distribution shown in Fig. 11. As previously discussed, data from the particle measurement probe in a cloud with small particle size and high particle count were not considered reliable. Consequently, the particle measurement probe data during the spray tanker test points also were not considered reliable.

Because TPS tile damage did not occur from spray tanker flights but did occur in natural rain, an inference can be made as to the maximum effective particle impact that could possibly exist in the spray tanker mist. The maximum speed of the tanker tests was 350 KIAS at an altitude of 11,700 ft, representing approximately 650 fps. Comparing the damage threshold of Fig. 13d (LI900 tile at 90°) at 650 fps indicates a particle size of approximately 1.7 mm. Thus it can be inferred that the maximum effective particle impact in the spray tanker mist was 1.7 mm or less.

### Summary

The following is a summary of the test results to date:

1. A viable in-flight test technique has been established for natural rain damage testing of TPS materials.
2. Various types of Shuttle TPS have been tested to the raindrop moisture impact damage threshold.
3. The USAF KC-135 spray tanker did not simulate natural rain impact damage and was dropped from subsequent tests.
4. Tiles exposed to several launch and landing cycles appear to fail at lower impact energies than new tiles.

5. The impact energy for damage varies with rain-drop size. The damage requires higher energy for large raindrop diameter relative to small raindrop diameters.

6. The impact energy for tile damage was higher during these flight tests than from single impact ground tests.

7. An advanced tuft tile was flown to damage threshold and failed at a significantly higher velocity than current LI2200 tiles.

8. Preliminary results indicate that launch or landing in light rain may be permissible without extensive tile damage; however, further testing and analysis are required.

### References

- 1 Korb, L.J.; Morant, C.A.; Calland, R.M.; and Thatcher, C.S.: "The Shuttle Orbiter Thermal Protection System." *Ceramic Bulletin*, vol. 60, no. 11, Nov. 1981, pp. 1188-1193.
- 2 Dotts, R.L.; Curry, D.M.; and Tillian, D.J.: "The Shuttle Orbiter Thermal Protection System Materials, Designs, and Flight Performance Overview." SAE Technical Paper Series 831118, July 1983.
- 3 Curry, D.M.; Scott, H.C.; and Webster, C.N.: "Material Characteristics of Space Shuttle Reinforced Carbon-Carbon." 24th National Society for the Advancement of Material and Process Engineering (SAMPE) Symposium, May 1979.
- 4 Sawko, P.M.: "Effect of Processing Treatments on Strength of Silica Thread for Quilted Ceramic Insulation on Space Shuttle." *Society for the Advancement of Material and Process Engineering Quarterly*, vol. 16, no. 4, July 1985.
- 5 Leiser, Daniel; Churchward, Rex; Katvala, Victor; Stewart, David; and Aliza, Balter: "Advanced Porous Coating for Low Density Ceramic Insulation Materials." *Ceramic Engineering and Science Proceedings*, vol. 8, no. 7-8, 1988.
- 6 Cooper, R.M.: *Rain Impact Assessment of Advanced Thermal Protection System Materials, Phase I Test Results*. Space Division, Air Force Systems Command, SD-TR-85-61, Sept. 1985.

Table 1. — In-Flight Rain Damage Threshold  
for TPS Tile Test Coupons

Tile	Angle, deg	Particle diameter, mm	Velocity, fps, for pitting
LI900			
New	15	2.1	795
New		2.7	740
New	30	1.5	722
New		1.55	860
Used		2.0	710
Used		2.2	565
New		2.2	625
New		2.2	670
New		2.2	780
New		2.3	700
New		2.3	720
New		2.5	680
New		2.7	650
Used		2.7	500
New		2.75	550
Used		2.9	610
Used	60	1.7	550
New		1.9	660
New		2.4	550
New	90	1.75	590
New		1.25	800
New		2.4	550
LI2200			
New	60	1.7	700
New		1.75	670
New		1.9	660
New		1.95	645
New		2.2	540
New		2.3	550
New	90	1.5	690
New		1.9	495
New		2.05	455
Tufi	90	2.2	793

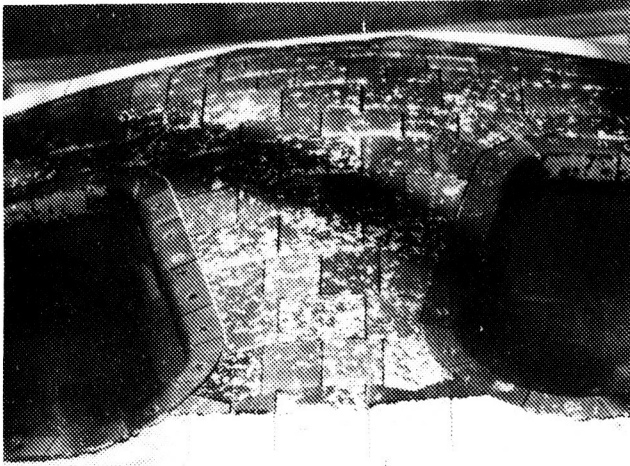

Table 2. — WP-3D Aircraft In-Flight No Damage  
and Damage Results for TPS Test Coupons

Tile	Angle, deg	Particle diameter, mm, resulting in no failures	Particle diameter, mm, resulting in failures	Velocity, fps
<b>LI900</b>				
New	30	3.6	3.8	309
Used		2.4	3.0	309
Used		2.6	2.8	417
New	45	2.6	3.6	309
New		2.6	3.2	393
Used		1.6	4.2	309
New	60	2.4	3.8	309
New		2.6	4.6	309
New		2.6	3.2	393
New		2.2	4.2	446
Used		1.8	2.8	309
Used		2.4	2.6	417
<b>LI2200</b>				
New	60	2.4	4.6	378
New		3.0	5.6	378

Table 3. — Maximum Conditions  
That TPS Test Coupons  
Were Flown Without Damage

TPS test coupons	Particle size, mm	Velocity, fps
RCC at 90° to free-stream flow	3.05	928.0
TPS at 0° to free-stream flow	2.7	698.0
AFRSI at 0° to free-stream flow	2.8	939.2



108-KSC-385C-3053/2

*Fig. 1 Shuttle Columbia windscreen area tile damage caused by rain during ferry flight atop 747 carrier aircraft, at 250 KIAS and 15,000 ft.*

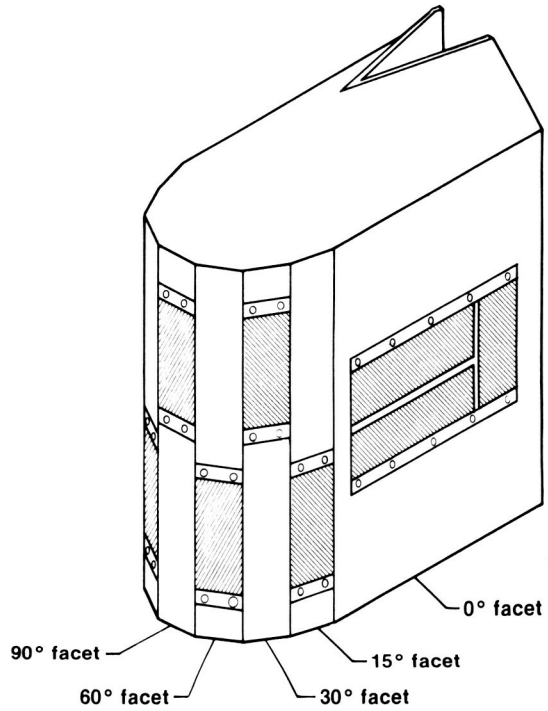

8242

*Fig. 3 Nosecap to hold thermal protection system on leading edge of flight test fixture.*

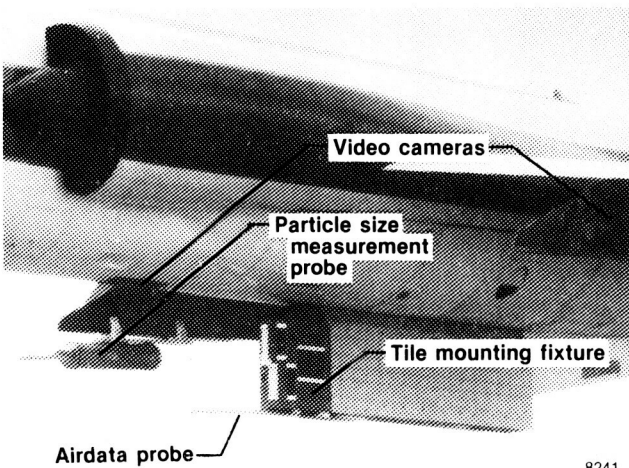

8241

EC-33378-027

*Fig. 2 In-flight photo of F-104 flight test fixture used for rain damage tests.*

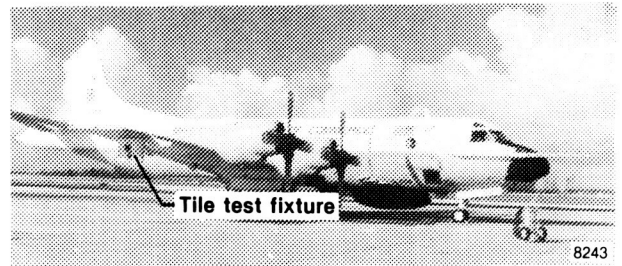

8243

586-25547

*Fig. 4 NOAA WP-3D aircraft with test fixture/pylon mounted on the lower surface of right wing tip.*

ORIGINAL PAGE IS  
OF POOR QUALITY

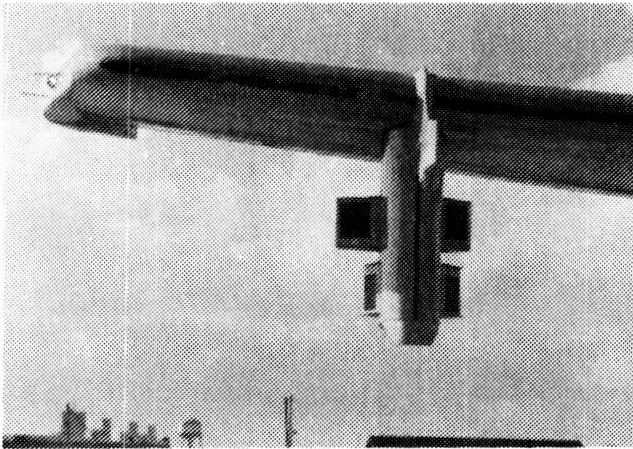

586-25548

(a) Forward view with test coupons extended at 15°, 30°, 45°, and 60°.

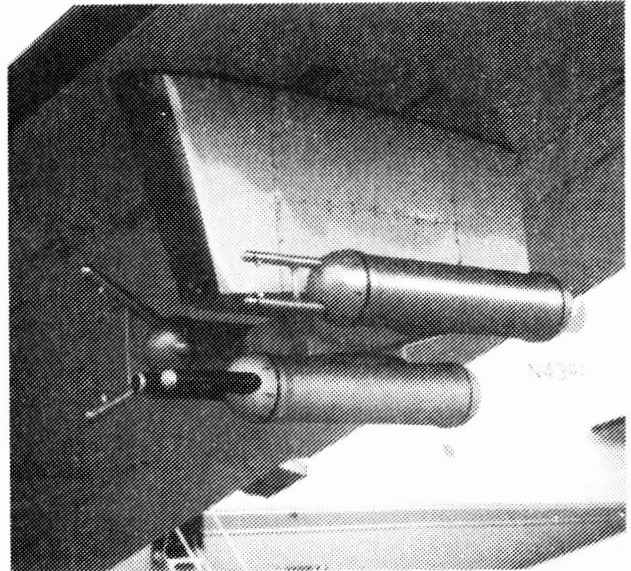
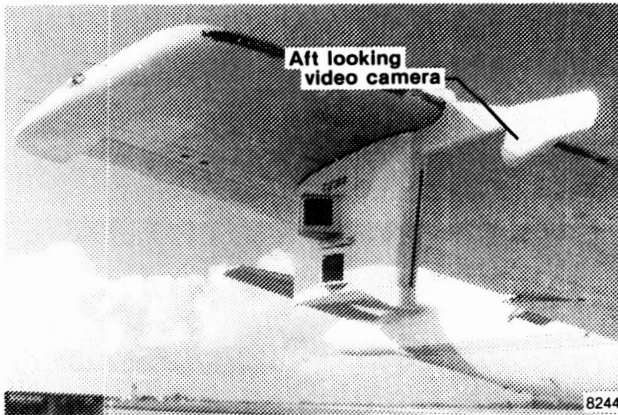

Fig. 6 Three particle measurement probes mounted on the WP-3D left wing tip pylon.



8244

586-25552

(b) Right-side view.

Fig. 5 NOAA WP-3D test fixture.



8245

EC85-33236-002

Fig. 7 Typical tiles prior to flight test in rain.

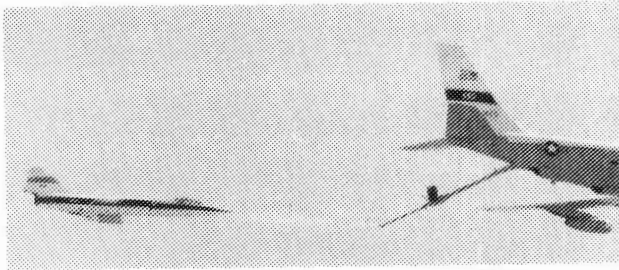

EC85-33000

*Fig. 8 In-flight photo of USAF KC-135 water spray tanker and F-104 test aircraft.*

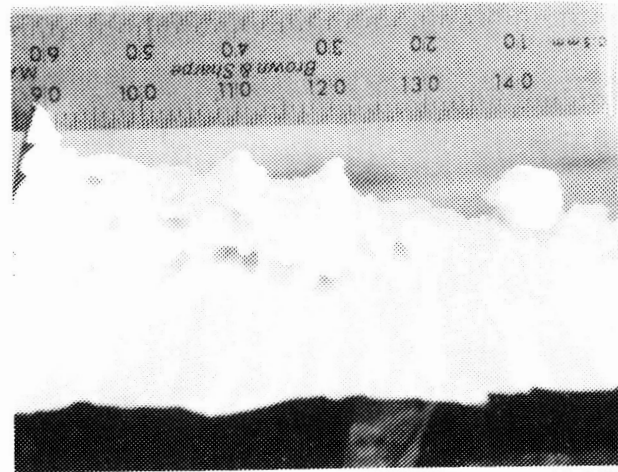

EC85-33216-013

*Fig. 10 Postflight example of TPS tile with small holes in substrate.*

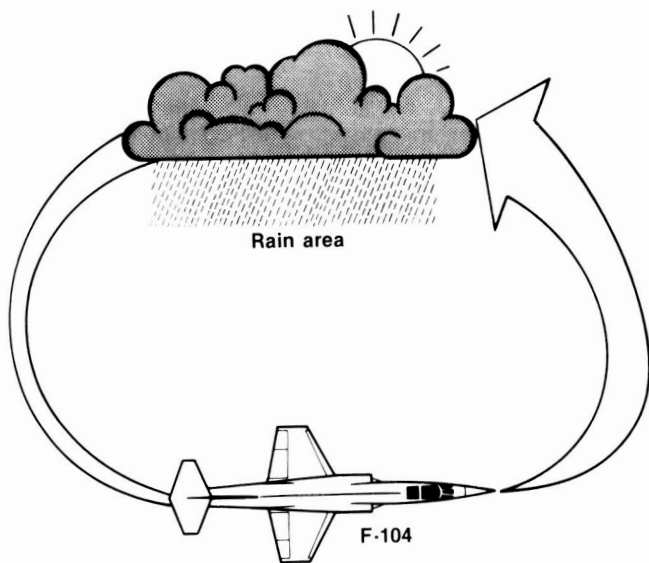

8246

*Fig. 9 Racetrack pattern used for F-104 rain erosion tests.*

ORIGINAL PAGE IS  
OF POOR QUALITY

ORIGINAL PAGE IS  
OF POOR QUALITY.

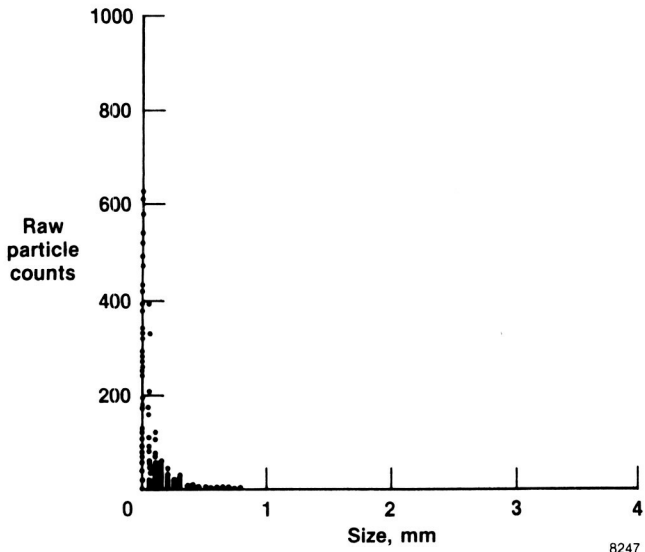

(a) 275 knots.

8247

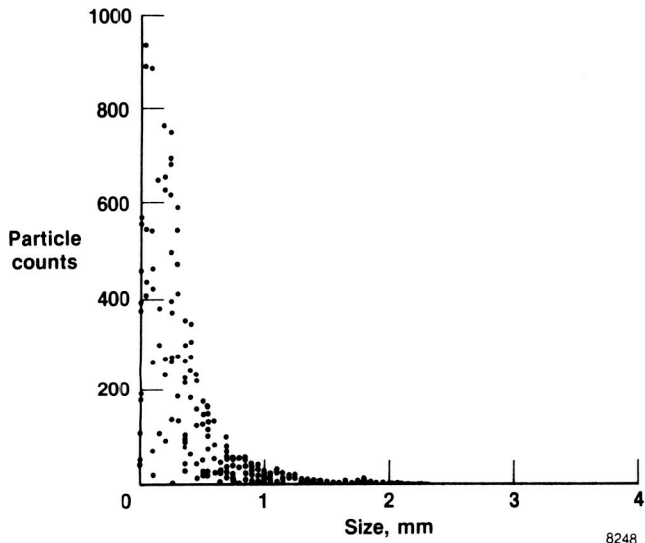

(b) 550 knots.

8248

Fig. 11 Particle count histogram from a cloud measured by particle measurement probe.

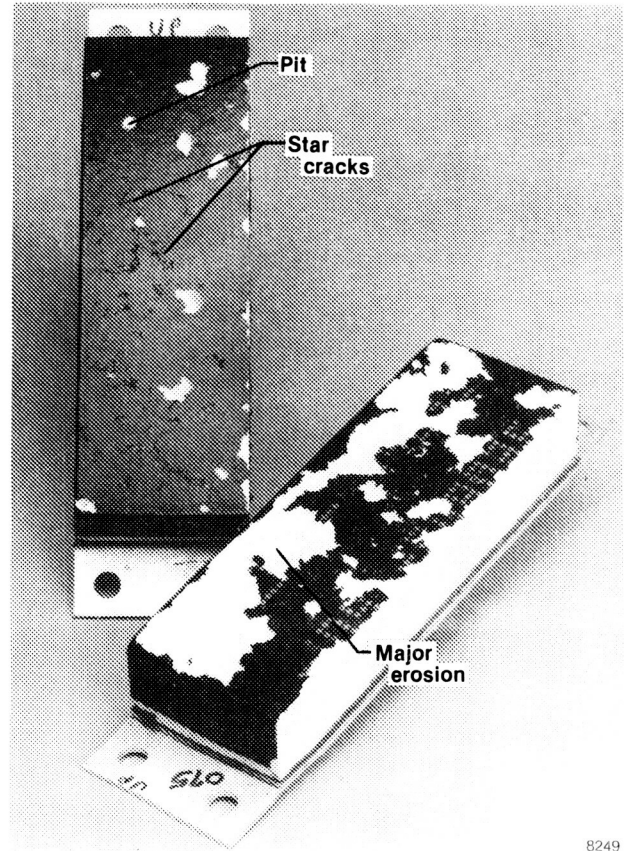

8249

E88-0002-001

Fig. 12 Examples of the three definable stages of damage to TPS LI900 tiles.

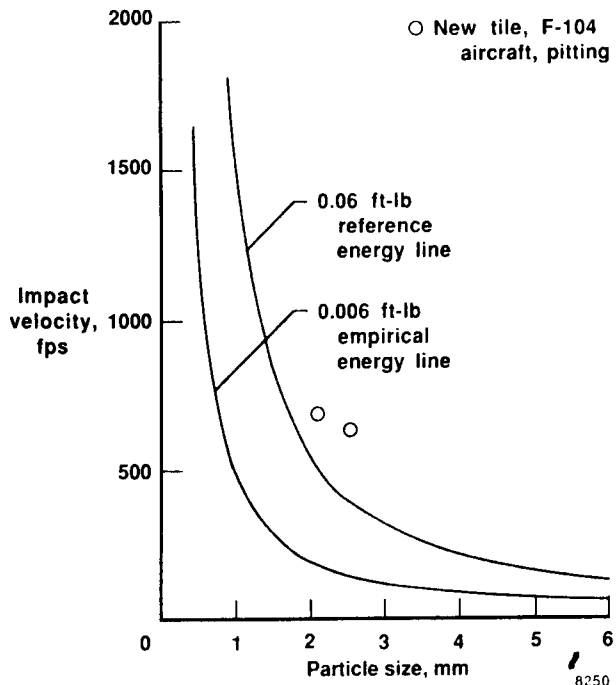

(a) 15° to free-stream flow.

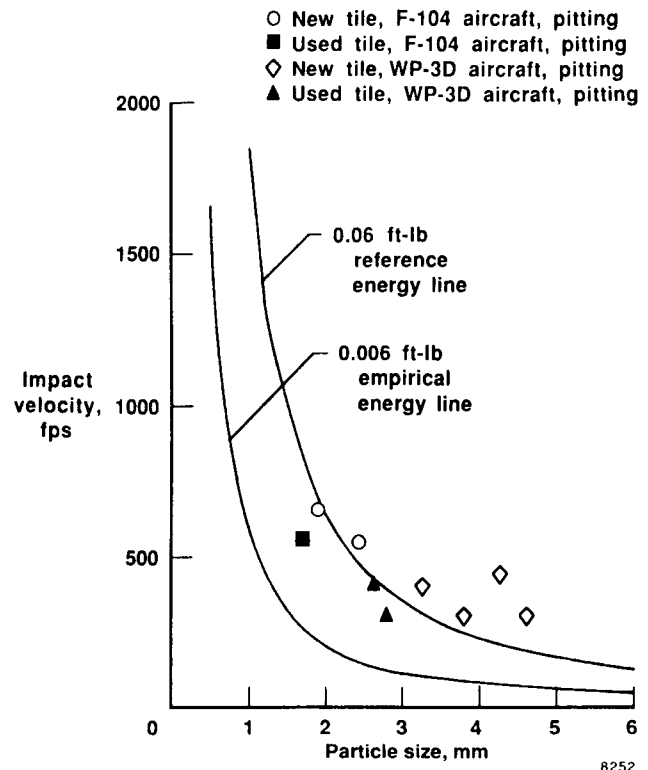

(c) 60° to free-stream flow.

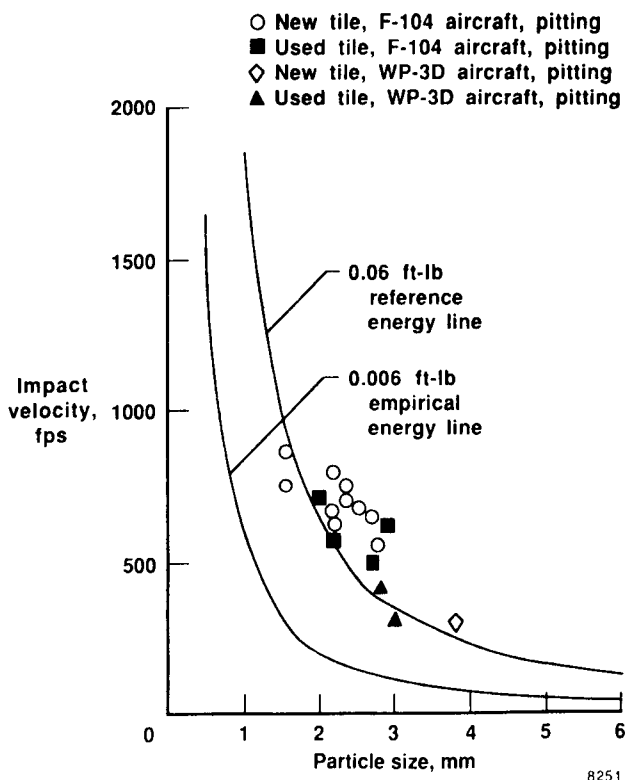

(b) 30° to free-stream flow.

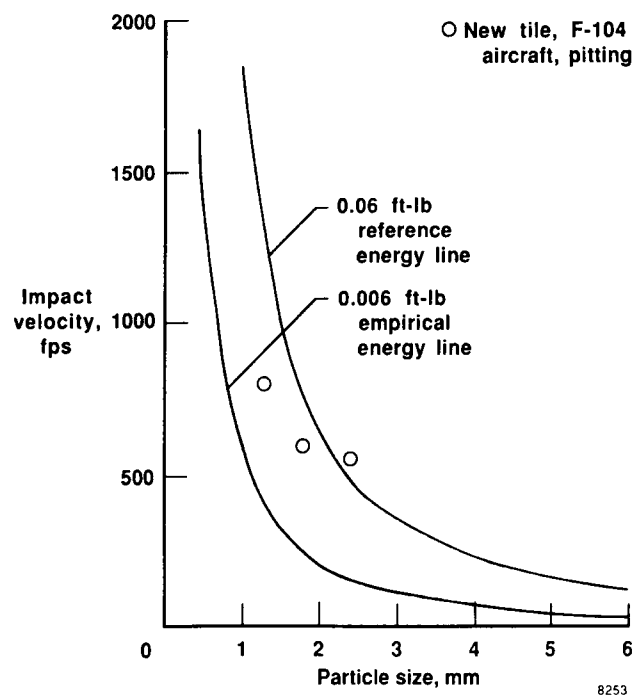

(d) 90° to free-stream flow.

Fig. 13 In-flight exposure of LI900 tile to rain.

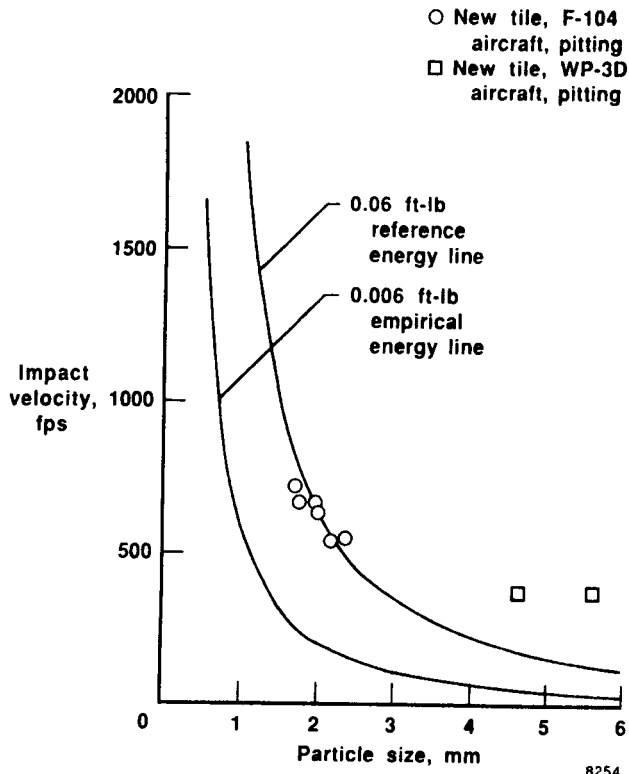

(a) 60° to free-stream flow.

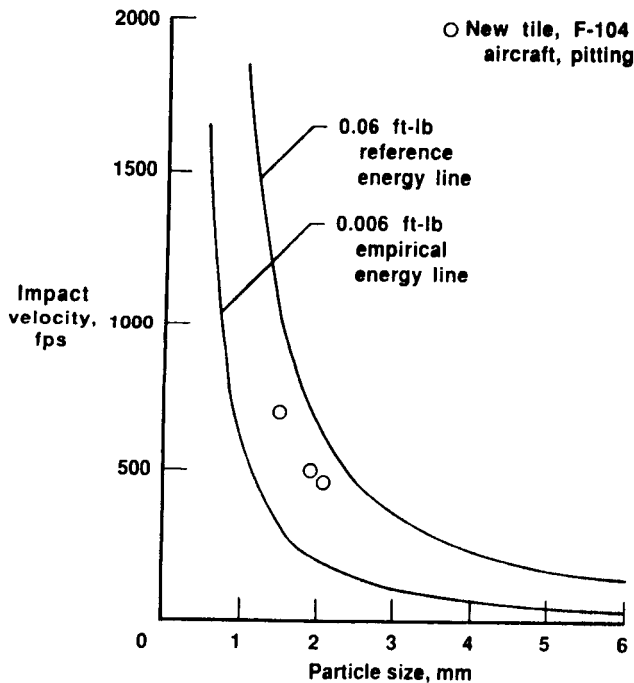

(b) 90° to free-stream flow.

Fig. 14 In-flight exposure of LI2200 tile to rain.

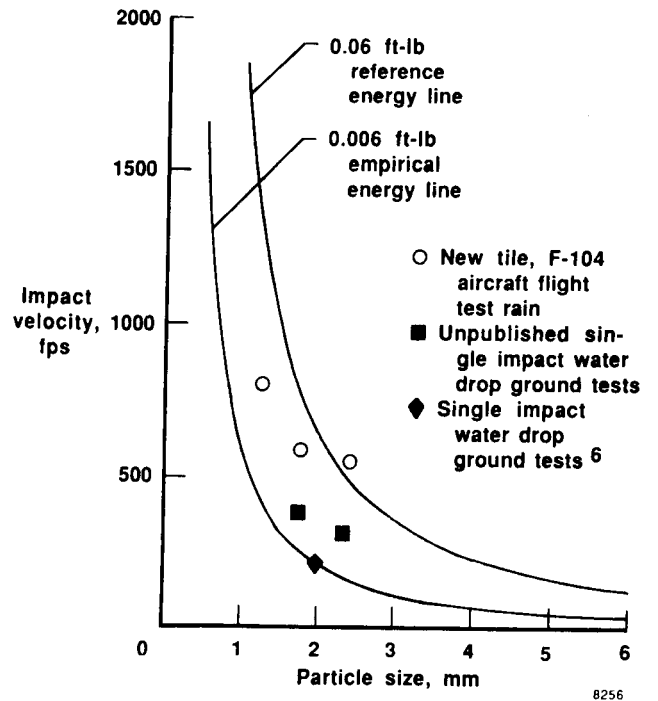

Fig. 15 Damage threshold for LI900 tile from flight and ground tests mounted at 90° to free-stream flow.

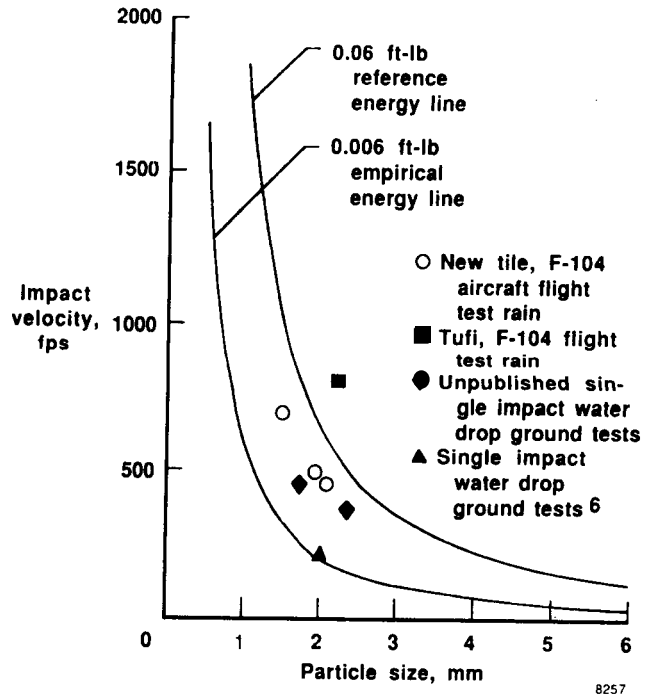

Fig. 16 Damage threshold for LI2200 tile from flight and ground tests and tufi mounted at 90° to free-stream flow.



# Report Documentation Page

<b>1. Report No.</b> NASA TM-100438		<b>2. Government Accession No.</b>		<b>3. Recipient's Catalog No.</b>	
<b>4. Title and Subtitle</b> In-Flight Rain Damage Tests of the Shuttle Thermal Protection System			<b>5. Report Date</b> May 1988		
			<b>6. Performing Organization Code</b>		
<b>7. Author(s)</b> Robert R. Meyer, Jr. and Jack Barneburg			<b>8. Performing Organization Report No.</b> H-1484		
			<b>10. Work Unit No.</b> RTOP 505-61-41		
<b>9. Performing Organization Name and Address</b> NASA Ames Research Center Dryden Flight Research Facility P.O. Box 273, Edwards, CA 93523-5000			<b>11. Contract or Grant No.</b>		
			<b>13. Type of Report and Period Covered</b> Technical Memorandum		
<b>12. Sponsoring Agency Name and Address</b> National Aeronautics and Space Administration Washington, DC 20546			<b>14. Sponsoring Agency Code</b>		
			<b>15. Supplementary Notes</b> Prepared for presentation as paper no. 88-2137 for the AIAA 4th Flight Test Conference, May 18-20, 1988, at San Diego, California.		
<b>16. Abstract</b>  NASA conducted in-flight rain damage tests of the Shuttle thermal protection system (TPS). The majority of the tests were conducted on an F-104 aircraft at the Dryden Flight Research Facility of NASA's Ames Research Center, although some tests were conducted by the National Oceanographic and Atmospheric Administration (NOAA) on a WP-3D aircraft off the eastern coast of southern Florida. The thermal protection system components tested included LI900 and LI2200 tiles, advanced flexible reusable surface insulation (AFRSI), reinforced carbon carbon (RCC), and an advanced tuff tile. The objective of the test was to define the damage threshold of various thermal protection materials during flight through rain. The test hardware, test technique, and results from both the F-104 and WP-3D aircraft are described. Results have shown that damage can occur to the Shuttle TPS during flight in rain.					
<b>17. Key Words (Suggested by Author(s))</b> Rain damage inflight Shuttle thermal protection system Surface fracture			<b>18. Distribution Statement</b> Unclassified — Unlimited  Subject category 18		
<b>19. Security Classif. (of this report)</b> Unclassified		<b>20. Security Classif. (of this page)</b> Unclassified		<b>21. No. of pages</b> 14	<b>22. Price</b> A02