

IT'S TIME TO REINVENT THE GENERAL AVIATION AIRPLANE

Robert Stengel
Princeton University

Current designs for general aviation airplanes have become obsolete, and avenues for major redesign must be considered. New designs should incorporate recent advances in electronics, aerodynamics, structures, materials, and propulsion. Future airplanes should be optimized to operate satisfactorily in a positive air traffic control environment, to afford safety and comfort for point-to-point transportation that is at least comparable to automotive travel, and to take advantage of automated manufacturing techniques and high production rates. These requirements have broad implications for airplane design and flying qualities, leading to a concept for the Modern Equipment General Aviation (MEGA) airplane. Synergistic improvements in design, production, and operation can provide a much-needed "fresh start" for the general aviation industry and the traveling public. Achieving these goals requires nothing less than the reinvention of the small airplane, providing new opportunities and requirements for research.

Although the term "general aviation" applies to a wide range of aircraft -- from single-engine, propeller-driven, single-seat planes to business jets -- the focus of this presentation is at the low end of the scale. Except as noted, a small four-place airplane is taken as a reference. Nevertheless, the proposed philosophy for new airplane design applies across the entire spectrum of general aviation.

IT'S TIME TO REINVENT THE GENERAL AVIATION AIRPLANE

Declining Practical Importance of
Small General Aviation Airplanes

New Technologies for Airplane
Systems

MEGA-Plane

Goals and Assumptions

Characteristics of a 4-Place MEGA-Plane

Opportunities for Research

DECLINING PRACTICAL IMPORTANCE OF SMALL GENERAL AVIATION AIRPLANES

For all practical purposes, the production of small general aviation (GA) airplanes in the United States has come to an end. The production rate for GA airplanes of all categories is about 1500 planes per year, less than 10 percent of what it was a decade ago. A thousand small GA airplanes were produced in 1986, but few of these were made by the manufacturers that formerly could be considered "The Big Three." Exports accounted for 30% of the US production; in the coming year, the General Aviation Manufacturers Association expects a comparable percentage of foreign imports, with a large concentration in the single-engine category. The average age of US small airplanes is 20 years old. The production of GA airplanes currently has minimal impact on the domestic economy. Although general aviation is said to be a \$15 billion business, only \$200 million of that can be attributed to the sale of small airplanes.

As fixed-base-operator income decreases, the idea of converting airfield real estate to condominiums and shopping centers becomes attractive, driving many small airports near major urban areas out of business. Small airports are losing the business of serious travelers, and an increasing number principally serve weekend pilots and flight schools. This trend is particularly detrimental to the national transportation system in view of the heavy congestion at most major airports, and it accelerates the decline in travel by GA airplane.

An ancillary point is that recent growth in commercial air travel has created a shortage of airline pilots. General aviation has long been a spawning ground for airline pilots, but it is not producing enough well-qualified pilots to meet the demand. One consequence is that relatively low-time pilots are flying in the right seats of many commercial aircraft cockpits.

Although important research continues in applicable technology areas such as stall/spin dynamics and aerodynamic flow control, neither the Federal Aviation Administration (FAA) nor the National Aeronautics and Space Administration (NASA) currently supports substantial research and development specifically directed at general aviation. If GA airplanes are no longer produced in the US or if GA flying must be perceived as the domain of the hobbyist and the well-to-do alone, it will be increasingly difficult to justify the expenditure of federal funds for its enhancement.

DECLINING PRACTICAL IMPORTANCE OF SMALL GENERAL AVIATION AIRPLANES

**Large-Scale Production of Small
Airplanes has Ended**

**GA Production Rates are Less Than 10% of What
They Were a Decade Ago (about 1500 planes/yr)**

**Small Airplanes Production is Less Than a
Thousand per Year**

**Three Major GA Manufacturers Currently
Produce Few Small Airplanes**

Small Airports are Closing

**Neither FAA nor NASA has Any
Substantial GA R&D Initiatives**

REASONS FOR THE DECLINE

There are many reasons for the decline in production of small airplanes. While numerous evolutionary changes have been incorporated in GA airplanes, most examples trace their basic designs to the late 1940s, with technologies established a decade or more earlier. Manufacturers find certification costs higher than ever before, and production costs are in an unstable spiral as the number of produced aircraft decreases. Except in special cases, there is a large disparity between the cost of owning and using a GA airplane and the cost of traveling by competing modes. The GA airplane may well be cost-effective in a small-business setting, particularly where a large area must be covered quickly on a regular basis; lacking a business subsidy, few middle-income travelers consider GA transportation affordable.

GA manufacturers are being found liable for an increasing number of airplane accidents, and the cost of liability insurance or "self-insurance" has become a significant percentage of the total cost of each new airplane. This is a disincentive not only to the airplane producer but to the potential owner, who must pay the added costs. While gains have been made, the accident rate for GA aircraft still is substantially higher than that for competing modes. The hazard is comparable to motorcycle riding and somewhat greater than traveling by commercial aircraft, train, or automobile. Air traffic control procedures have become more complex with airline deregulation and increasing commercial air travel, and future GA travel is likely to be limited even more in view of productivity and fuel-use considerations. Flying an airplane in poor weather conditions demands a high level of IFR proficiency, something that relatively few GA pilots can achieve and maintain.

Finally, there is real confusion about the goals of general aviation. Should it be considered as a candidate mode for transporting large numbers of people? Should travel by small airplane be more like sailing to Bermuda or driving to Pittsburgh? Can general aviation have a major impact on the economy? Should particular classes of general aviation (e.g., air taxis and corporate aircraft vs. personally owned small planes) be singled out for special treatment? Without answers to these and similar questions, general aviation will decline even further.

REASONS FOR THE DECLINE

Slow Incorporation of New
Technologies

High Costs of Certification, Production,
and Operation

High Costs of Liability

High Accident Rates in Comparison to
Other Modes of Transportation

Increasingly Complex Air Traffic
Control Regulations

High Level of Piloting Proficiency
Required for All-Weather Flying

Confusion About GA Goals

NEED FOR A RESURGENT GENERAL AVIATION INDUSTRY

General aviation provides unique capabilities for rapid point-to-point travel for small groups of people. It is complementary to the hub-to-hub and hub-spoke services of the major and feeder airlines. With area navigation and sufficient satellite airports, general aviation airplanes can be routed through under-utilized airspace, avoiding areas of congestion both in the air and on the ground. By diverting significant numbers of travelers from the public carriers, general aviation could actually reduce congestion in the terminal area. Just as automobile travel between two suburbs often is quicker, cheaper, and more efficient than public ground transportation into and out of a neighboring metropolis, general aviation offers a potentially attractive alternative for many trips between points not near large airports.

Improving reliability and safety are continuing issues in all modes of transportation. No matter what the current level, we always seek to lower the costs of operation, to simplify maintenance, to facilitate on-time performance, and to reduce the risks inherent in travel. In order for new GA airplanes to attract potential buyers, they must provide benefits in comparison to the competition -- used airplanes or new planes produced by other (possibly foreign) manufacturers.

The production of small airplanes could be a multi-billion-dollar business. The two most likely outcomes of not rebuilding the GA industry will be the *de facto* encouragement of foreign airframe and engine manufacturers to introduce their products to the US market and the loss of additional foreign markets for American products. Yet another business will be converted from a manufacturing to a service industry, with its attendant diminution of technical leadership and long-term economic security.

There is an opportunity -- if not an imperative -- to ask the question, "If we were unfettered by the need to adapt new technologies to old designs in piecemeal fashion, how would we design small airplanes?" Or put another way, "How would we invent the GA airplane to satisfy the needs of potential users while accounting for the realities of the National Airspace System and providing a reasonable incentive to prospective manufacturers to build such airplanes?"

NEED FOR A RESURGENT GENERAL AVIATION INDUSTRY

Transportation Requirements of the
Public

Continuing Drive for Improved
Reliability and Safety

Stimulation of Domestic Economy

Increasing Domestic Dependence on Foreign
Suppliers

Lost Foreign Market Opportunities

NEW TECHNOLOGIES FOR GENERAL AVIATION AIRPLANE SYSTEMS

There is an exciting array of new technologies that, for the most part, have not been applied to the production of small airplanes. Some of them are listed here.

Electronics - In little more than a decade, the microprocessor has revolutionized many products and services, but it has done little for the GA airplane. It can provide the focal point for a host of major improvements. Together with concurrent advances in sensors, actuators, displays, and external systems, it can spearhead the drive for a new level of performance, reliability, and safety in GA production and operation. At the same time, flight-critical electronics introduce new concerns that must be addressed during design and operation, including guaranteed uninterrupted power, lightning protection, mode switching, and complex control logic, all at a far lower cost than is normally associated with avionics equipment.

Modern Manufacturing Techniques - While it is unlikely that production rates would ever approach those of automobiles, much can be learned from advances being made in the automotive industry. Today's GA airplanes are essentially custom-made, deriving little benefit from common production-line concepts; however, modern manufacturing techniques emphasize flexibility, using computers, communication networks, and robotic devices (including numerically controlled machines) to perform a wide variety of functions from preliminary design to painting the end product. This flexibility is precisely what is needed in GA airplane production.

Structures and Materials - New materials not only promise direct benefits: they provide an opportunity for redesigning the basic airplane structure. Furthermore, modern objectives such as enhanced crash survivability and lightning protection can be combined with traditional design considerations like weight, air loads, and fatigue through the use of computational analysis. Composite materials offer strong and lightweight alternatives to aluminum components, although aluminum remains the cost-effective choice for most primary structures.

NEW TECHNOLOGIES FOR GENERAL AVIATION AIRPLANE SYSTEMS

Electronics

Microprocessors
Fiber Optics
Integrated Motion Sensors
High-Flux-Density Electric Motors
Electronic Displays
Weather Sensors
Precise Long-Range Navigation
Air Traffic Control Systems

Modern Manufacturing Techniques

Computer-Aided Design
Computer-Integrated Manufacturing
Robotics

Structures and Materials

Composites
Aluminum Alloys
Honeycomb
Integrated Structures

NEW TECHNOLOGIES FOR GENERAL AVIATION AIRPLANE SYSTEMS, continued

Aerodynamics - There is a widespread misconception that we have learned all we will ever know (or need to know) about subsonic aerodynamics. In fact, some rather dramatic breakthroughs have been made in recent years, and it is likely that there is much more to come. While seemingly redundant, three controllable horizontal surfaces for lift, stability, and control (canard, wing, and tail) provide a number of advantages, including reduced wing size, optimization of cruise condition to reduce trim drag, and stall/spin protection. Control surfaces need not be coupled mechanically as in the past; hence, there is a high level of redundancy that can be put to good use in improved safety margins. It is now realized that a combination of modern surface finishing techniques and shape selection can provide natural laminar flow over large segments of wings and fairings, reducing drag and improving overall performance. New perspectives on wing design suggest that significant gains in lift/drag ratio can be realized by reshaping the planform, particularly in the vicinity of the tips, as well as the airfoil.

Propulsion - Great strides have been made in automobile engines, suggesting avenues for improving the reciprocating engines of small airplanes. Computer-controlled electronic ignition, improved combustion chambers, multiport valving, and turbocharging all could contribute to increased safety, reliability, and efficiency. The new engines could be designed to use automobile gasoline with no loss in performance or economy, solving one of the more pernicious problems of operating small planes today. Computational fluid dynamics, new perspectives on laminar flow control, and recent developments in propeller design for human-powered airplanes, the world-circling *Voyager*, and wind turbines all can further advance propulsive efficiency.

NEW TECHNOLOGIES, continued

Aerodynamics

Three-Surface Longitudinal Control

Control Surface Redundancy

Natural Laminar Flow

Planform and Wingtip Design

Propulsion

Automotive Ignition and Combustion Technology

Propeller Design

THE MODERN EQUIPMENT GENERAL AVIATION AIRPLANE (MEGA-Plane)

The principal objective for the "reinvented" GA airplane is to provide a viable alternate form of transportation for a large number of air travelers, in much the same way that automobiles provide a desirable alternative to public ground transportation. The goal is not to redefine our notions of existing GA concepts but to redefine the GA concepts themselves, to make general aviation something that it is not today. The goal is to design a new breed of airplanes that really do make private flying a constructive segment of the National Transportation System through the use of modern technology and manufacturing techniques.

Starting over in the design of small airplanes will result in synergistic benefits that would otherwise be unattainable. In effect, the whole design process is "rubberized", identifying desirable attributes in one system, evaluating the impacts of these attributes on other systems, and redefining the latter accordingly. For example, if independent, reconfigurable control surfaces are desirable (which they are) but they require uninterrupted electrical power with extremely low mean failure rates (which they do), existing systems for power supply and distribution are unacceptable. A new standard for power system design is mandatory, and such a system will, no doubt, contain redundancies that are not currently considered necessary. There is good reason to believe that the redesign can be achieved, given modern technology and no predetermined requirement to interface with traditional elements. Furthermore, by designing for the production process and reasonable production rates, costs will be minimized.

It is essential to take bold steps in planning for what amounts to a major overhaul of the National Transportation System. Clearly, the impact of a large increase in small airplane traffic would be great, and without a comprehensive approach that considers not only production and distribution but operation within the confines of the National Airspace System, that impact would be calamitous. There is a lot of unused airspace that could be used safely and efficiently, with virtually no infringement on airline operations. "Back-of-the-envelope" calculations suggest that a million GA airplanes (about five times the current number) would produce a volumetric density that is on the order of one hundred million times smaller than ground traffic density. Still, this space is unusable without positive assurances that airplanes will not interfere with each other. Consequently, the reinvented GA airplane must have a degree of autonomy and compatibility with other airplanes that is not realized in current designs.

**THE MODERN EQUIPMENT GENERAL
AVIATION AIRPLANE
(MEGA-Plane)**

Objective:
Fast, Reliable, Safe, Comfortable, Cheap
Transportation for Large Population of
Travelers

Synergistic Use of New Technologies

No Need for Compatibility with Old Technology
Design for Low-Cost Automated Manufacturing
All-Electric Control Actuation
Reciprocating Engine(s)

Planning for GA to Become a Major
Component of the National
Transportation System

Production Rate of 50,000 Airplanes/yr by 2000

Equilibrium GA Population of 1,000,000
Airplanes by 2015

MEGA-PLANE, continued

The reinvented GA airplane should be as simple as possible, containing few clever-but-failure-prone mechanisms. It is, for example, preferable to forego the extra aerodynamic efficiency of an intricate flap deployment mechanism in favor of a simply hinged flap with a single rotational degree of freedom. The latter device is less likely to fail, is easy to fix when it does, and provides a backup roll control device. Systems should contain line-replaceable units that are comprehensive in function, individually reliable, easily understood, and easily replaced. Redundancy should be provided where single-string reliability is inadequate; however, as automatic redundancy management in modern flight control systems often grows to dominate software specifications, the airplane should be designed to allow the pilot to do as much redundancy management as possible. This means that failure modes should be forgiving, allowing time for human decision making. In a similar vein, the airplane's flying qualities must be good enough to allow a relatively inexperienced (or not current) pilot to maintain safe control in a wide range of flight conditions, including those that generate high workload in existing airplanes (weather, traffic, etc.).

The reinvented GA airplane must be specifically designed for ATC system compatibility, or else none of the suggested improvements can be realized. The area navigation system is as important as the wings and engine of this airplane. It must be integrated with sufficient communication links to allow positive control at all times, and it must provide the pilot with the same sorts of cues that road signs, maps, and traffic lights provide the automobile driver.

There is an important caveat: positive air traffic control may not have the same meaning with this airplane that it has for current airplanes; it may be much less restrictive than the current ATC system. In the future, positive control for small planes operating outside major terminal areas could be more like positive control for today's automobiles, consisting of the equivalent of traffic lights and limited-access highways, with automated up- and down-link of important information, e.g., airplane identifier, location, destination, approved routing, and so on. Furthermore, by adhering to more stringent design and operational requirements, the reinvented GA airplane could be allowed to have preferential departure, routing, and arrival assignments without degrading safety or airline scheduling.

MEGA-PLANE, continued

Simplified Design for Certification and Operation

Improved Inherent Safety, Reliability, and
Maintainability
Forgiving Failure Modes
"Video Game" Flying Qualities

Design for Air Traffic Control System Compatibility

Operation Under Positive Control 100% of the
Time
Fail-Safe Area Navigation
Preferential Priorities for MEGA-Planes

CONCEPT FOR A TYPICAL 4-PLACE MEGA-PLANE

To provide a tangible idea of what a MEGA-Plane might be, a concept for a 4-place, single-engine design is discussed. This figure is a sketch, not a detailed drawing; it presents a concept for a MEGA-Plane, not the MEGA-Plane. The configuration appears similar to existing airplanes, and most of its characteristics have been suggested separately in earlier work. The most obvious difference is the addition of a controllable canard surface in addition to a conventional horizontal tail. More subtle visual characteristics include a split rudder, a "T" tail, small wing area, swept wing tips, large window area, fixed gear, and a sizable storage compartment.

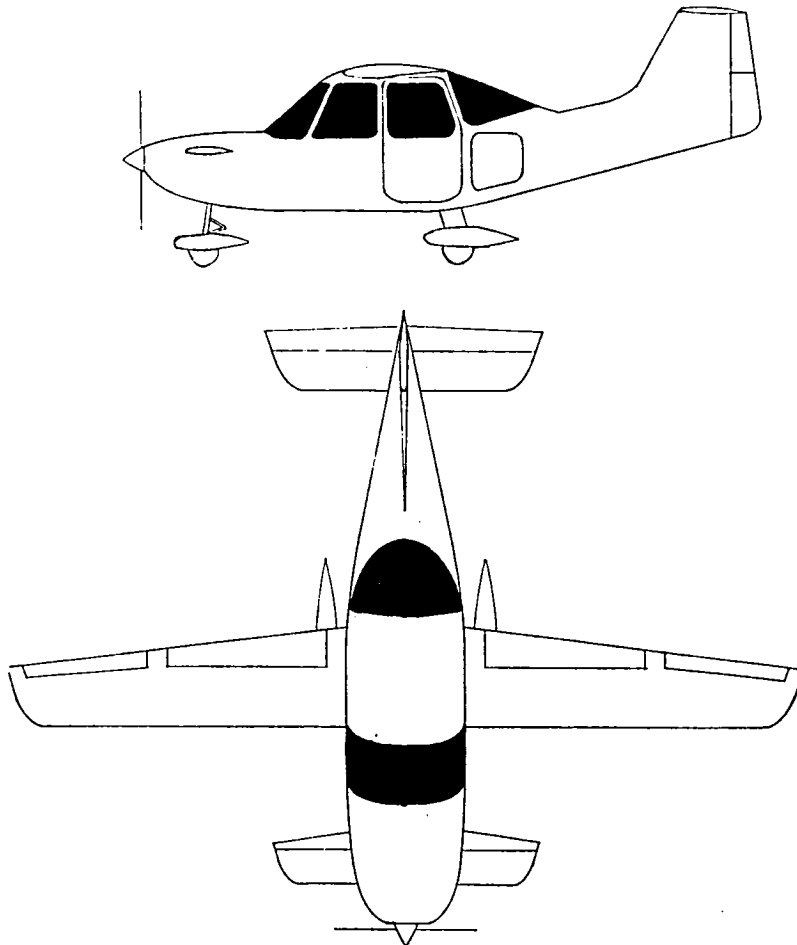

CONCEPT FOR A TYPICAL 4-PLACE MEGA-PLANE

AERODYNAMIC FEATURES

The principal control features of the airplane are its 3-surface longitudinal control, control redundancy, and simple flaps. Three-surface control provides a number of desirable attributes, including increased allowable center-of-gravity travel, pitch trim for minimum cruise drag, pitch control redundancy, and reduced wing area. (The latter comes about because the canard, unlike the rear tail, can provide positive angular rotation and positive lift for takeoff, eliminating the otherwise necessary download of the tailplane.) Because the canard control surfaces are immediately behind the propeller, they deflect the slipstream, providing strong forces and moments that can be used to reduce takeoff distance, to implement gust alleviation for improved ride qualities, and for stall/spin prevention (or recovery).

Each control surface is independent, i.e., not connected mechanically to any other surface; hence, there are 10 surfaces that can be used in numerous combinations to produce 3 forces and 3 moments for control. (Although not a primary requirement, it would be possible to produce side force for wings-level crosswind landings.) Consequently, ailerons could act like flaps and flaps like ailerons in the event of failure, within possibly reduced limits.

Recent flight research has shown that dramatic reductions in drag can be achieved by encouraging natural laminar flow over the airplane. Similarly, long-held notions of planform effects are being questioned; there is the possibility that swept tips and even more dramatic treatments such as sheared tips, crescent planforms, and serrated trailing edges may further reduce subsonic drag.

Although a redundant fly-by-wire/light control system is indicated, the MEGA-Plane should have inherent aerodynamic stability about all axes, allowing the "forgiving failure modes" mentioned earlier and eliminating the need for a stability augmentation system. (Closed-loop control may be desirable for a number of reasons; however, it should not be mandatory for safe flight.) While the airplane should never find itself in a spin, if it does enter the spin, it should have "honest" recovery characteristics, as implied by the unshadowed vertical tail and the full-length rudder.

CONCEPT FOR A TYPICAL 4-PLACE MEGA-PLANE

NATURAL LAMINAR FLOW
AIRFOILS and FAIRINGS

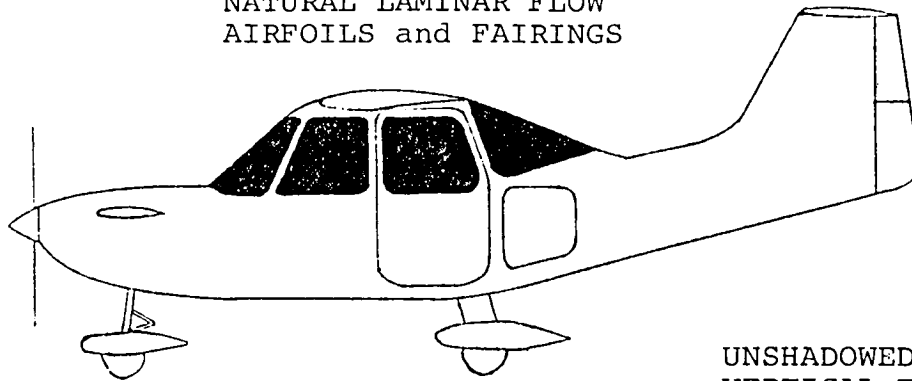

UNSHADOWED
VERTICAL TAIL

REDUNDANT
CONTROL
SURFACES

INHERENT
AERODYNAMIC
STABILITY

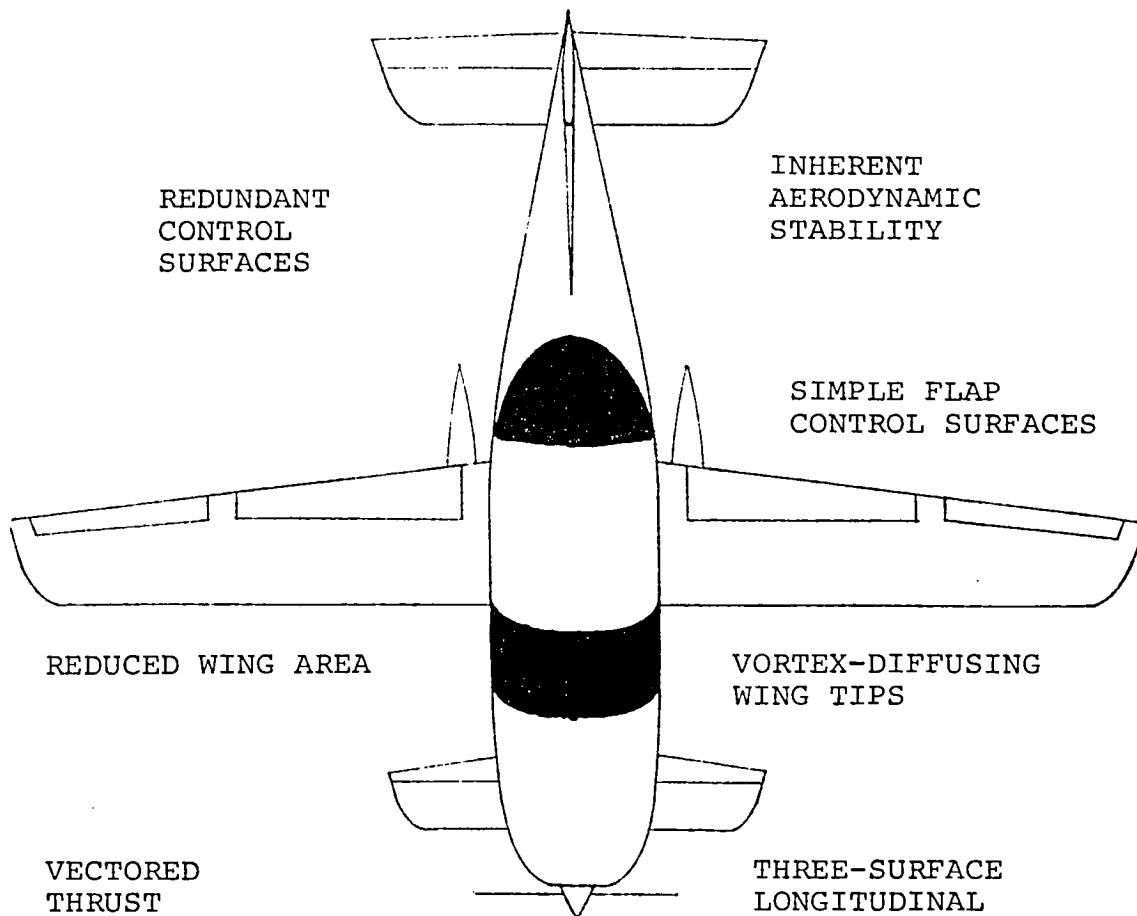

SIMPLE FLAP
CONTROL SURFACES

REDUCED WING AREA

VORTEX-DIFFUSING
WING TIPS

VECTORED
THRUST

THREE-SURFACE
LONGITUDINAL
CONTROL

AERODYNAMIC FEATURES

CONCEPT FOR A TYPICAL 4-PLACE MEGA-PLANE

SYSTEM & STRUCTURAL FEATURES

The all-electric/fiber-optic control system provides redundant, direct commands and power to all control actuators with a reliability that is at least equivalent to current pushrod-and-cable systems. In overall use, control reliability would be considerably better than that of current mechanical systems because individual control surface failures will not have disastrous effects -- in fact, with one or two random failures, the changes in flying qualities would be barely discernable. Electric actuation is possible because the hinge moments for this small airplane need not be large. There would be considerable cost and reliability benefits from using identical actuators on all control surfaces. Fail-safe area navigation would be integrated with the flight control system; both systems would be aided by the use of solid-state motion sensors, as well as external navigation aids like LORAN. The integrated navigation, guidance, and control system would have artificial intelligence attributes as well as anti-wind shear/wake vortex features, which can be provided at minimal cost by existing microprocessors. Cockpit instruments also should be all electric, with a minimal complement of backup air-driven instruments to allow for display failure. Although the "see-and-avoid" approach to collision avoidance has been totally discredited over the years, optical aids that are visible in daylight should be mandatory.

While flight loads establish firm constraints, the airplane structure should be designed for inexpensive, automated fabrication and assembly. Common, "pre-fabricated" components should be used where appropriate, and major elements should be designed to minimize the need for labor-intensive operations. While much enthusiasm has been generated for composite materials lately, it is not clear that they present the minimum-cost solution to small airplane construction when labor and time costs are taken into account. There is a strong likelihood that large components would be made from aluminum, with small components and panels that can easily be molded into shape being made from composites.

For reasons mentioned earlier, advanced propulsion technology is warranted. With the increased importance of electrical power dictated by the control system, an auxiliary power unit and large batteries are appropriate. The APU should not only provide electrical power; it should be designed to support anti-icing capability for the primary aerodynamic surfaces.

CONCEPT FOR A TYPICAL 4-PLACE MEGA-PLANE

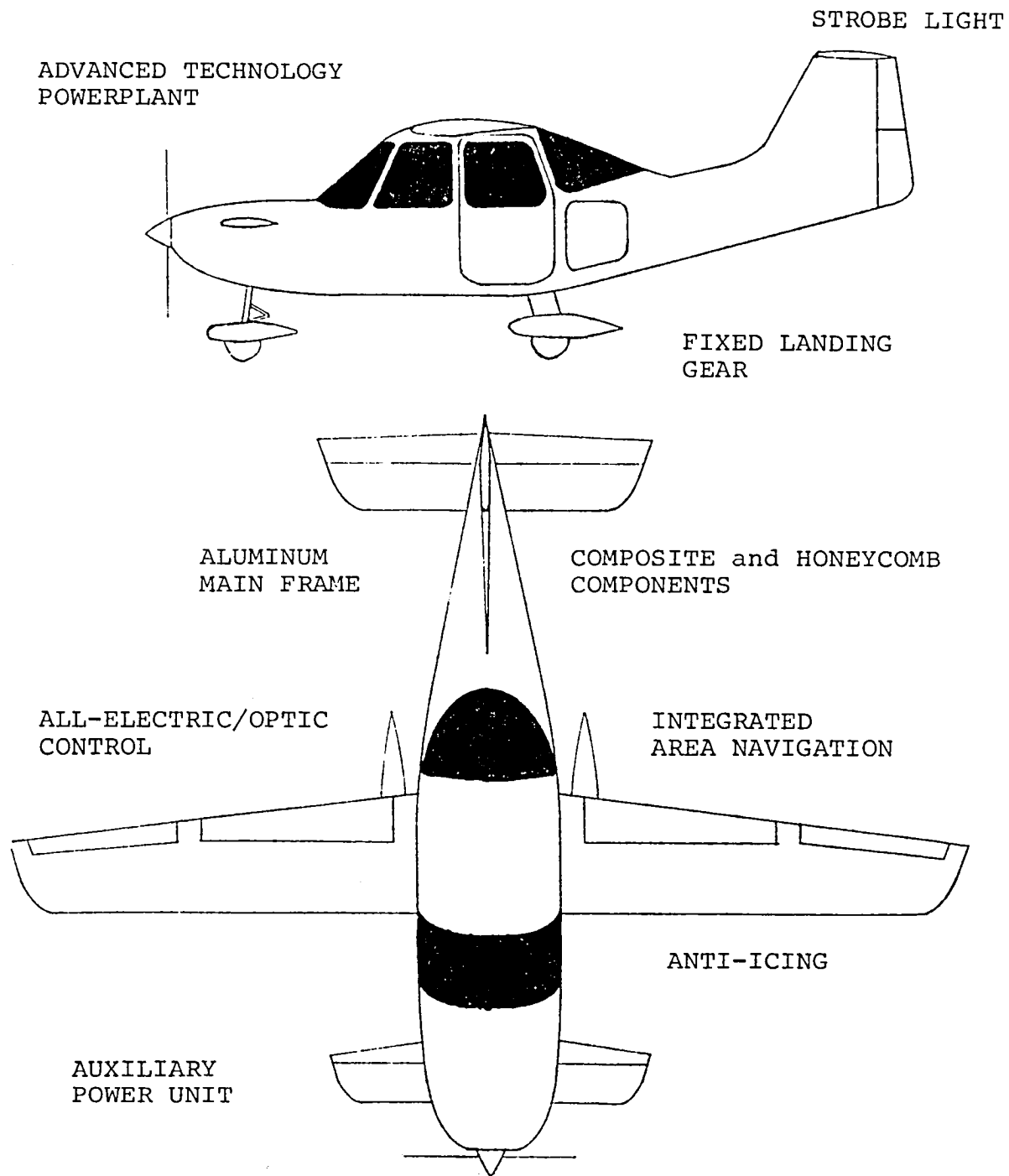

SYSTEM and STRUCTURAL FEATURES

CONCEPT FOR A TYPICAL 4-PLACE MEGA-PLANE

REDUNDANT CONTROL CHANNELS

Because the loss of control more often than once per some large number of flights (e.g., 10^9) is an unacceptable risk, it is likely that control system redundancy would be required. While the necessary level of redundancy is system-specific and should be the subject of intensive study, the sort of strategy that can be applied is suggested by this figure. The present objective is not to pre-design the system but merely to indicate that high reliability may be achievable in a fairly simple fashion.

There are two primary systems, each of which commands a different set of control surfaces and both of which operate in parallel in normal conditions. Both can command single units, such as the engine and auxiliary power unit, separately, and both accept the same pilot commands. In the event that either computer fails, a third computer (a "hot spare") would be brought on-line; in normal operation, the third computer would monitor the other two. If either primary string fails altogether, the other string can maintain control with the remaining control surfaces. The implication is that each string in a 2-string system must be individually quite reliable, with a mean-time-between-total-failures on the order of 40,000 hr (about $4\frac{1}{2}$ years of operation). Individual components could fail much more frequently; this large figure applies to all components in a single string failing simultaneously. Even in this case, the other 40,000-hr string would still be adequate to continue safe flight, and the spare computer would remain at the ready.

CONCEPT FOR A TYPICAL 4-PLACE MEGA-PLANE

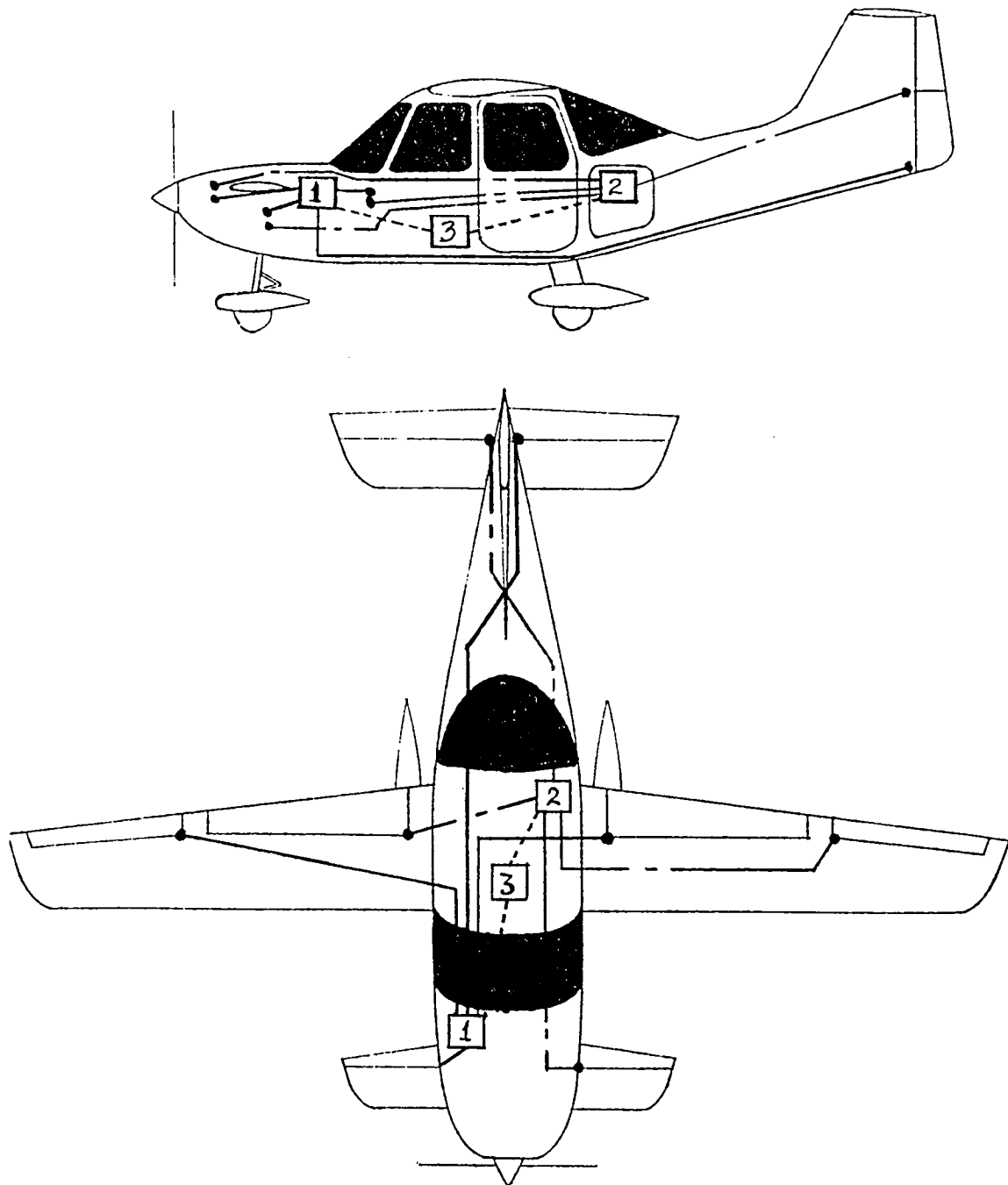

REDUNDANT CONTROL CHANNELS

OPPORTUNITIES FOR RESEARCH

Reinventing the small GA airplane is a systems problem, involving airplane design, human factors, and the air traffic control interface. This paper does not provide all the answers. It presents a concept and raises a challenge to the US aeronautical establishment, including government agencies, industry, and universities: conduct the research that is needed to make general aviation the vital contributor to economic, social, and transportation requirements that it can be.

Now in its fifteenth year, the FAA/NASA-sponsored Tri-University Program on Air Transportation Technology can play an important role in this research. Each of the participating universities -- Massachusetts Institute of Technology, Ohio University, and Princeton University -- provides unique perspectives and talents to be applied to the task. Together, we have demonstrated capabilities in literally all of the technologies that must be marshalled to produce this new generation of airplanes and the corresponding upgrade in the air traffic control system.

OPPORTUNITIES FOR RESEARCH

MEGA-Plane Development is a
Systems Problem, involving

Aircraft Design
Human Factors
Air Traffic Control Interface

Well-Defined Roles for FAA, NASA,
Industry, and University Participants

Candidate Focal Point for
Tri-University Program