

## LMSS PROPAGATION MODELING

## AT VIRGINIA TECH

Warren L. Stutzman, R. Michael Barts,  
and Charles W. Bostian

Satellite Communications Group  
Bradley Department of Electrical Engineering  
Virginia Polytechnic Institute and State University  
Blacksburg, VA 24061

**Abstract**--In this paper recent efforts in the modeling of land mobile satellite systems are reported. These include descriptions of a simple model for prediction of fading statistics, a propagation simulator, and results from studies using the simulator. Predictions are compared to available measured data.

## 1. Introduction

First generation MSS voice channels are being planned with as little as 3 dB margin. [Rafferty, Dessouky, and Sue, 1988] Small power margins are common for fixed service applications of satellite links. However, mobile satellite service presents special problems. In land mobile the line-of-sight path (LOS) is frequently blocked by trees and structures. For suburban and rural roads tree shadowing is statistically significant. A recent review article by several researchers in the MSS research community summarizes the measurements and modeling work to date for MSS propagation. [Stutzman, 1988]

In this paper we report on MSS propagation modeling activities at Virginia Tech. Because of the low signal margin, it is important to quantify the propagation effects. Experiments offer a direct or quasi-direct means of quantifying propagation effects; however, such experiments are costly. Also, there are many parameters in the MSS environment and not all vehicle travel situations can be measured. Instead, reliable models allow study of system performance for controlled propagation conditions. It is in this context that our modeling program is being developed.

## 2. Theoretical Background

Model development for MSS propagation is following a course similar to that for (fixed) satellite-to-earth propagation through rain at microwave frequencies. (This is not entirely coincidental because many of the same researchers are also involved in MSS propagation research.) There are several steps that must be taken in proper order. First, as complete a theoretical model as possible which describes the physics of the problem is set up. This is more difficult for vegetatively sha-

dowed propagation in the MSS problem than for microwave propagation through rain. The theoretical model will have several parameter values that are unknown and that can only be obtained by measurement. This is where direct measurement results are necessary. Next, simple models for the propagation environment are developed to drive the theoretical model. Finally, simple models are built that do not require evaluation of complicated theoretical expressions but still include the parameter variations. MSS propagation modeling is developing faster than rain propagation modeling did because data (required to establish model parameter values and to verify models) can be collected much faster. In the rain propagation problem prediction of annual statistics requires years of data collection, whereas data of statistical significance can be collected in a matter of hours with a mobile experimental unit for MSS.

The MSS signal is divided into two components: unshadowed and vegetatively shadowed. Each is treated separately and then the results are combined to form a complete model. The total distribution function for fade level F in a mixed shadowed/unshadowed mobile path is expressed as [Bradley and Stutzman, 1985; Lutz et al., 1986]

$$C(F) = C_U(F)*(1-s) + C_S(F)*s \quad (1)$$

where  $C_U(F)$  is the fade distribution for an unshadowed signal,  $C_S(F)$  is the fade distribution for a shadowed signal, and  $s$  is the fraction of vegetative shadowing along the mobile path. The unshadowed distribution function,  $C_U(F)$ , arises from an unobstructed line-of-sight component with Rayleigh distributed multipath, resulting in a Rician distribution with one parameter  $K$ , which is the carrier-to-multipath ratio. The distribution function associated with pure vegetatively shadowed paths,  $C_S(F)$ , results from a lognormally distributed LOS signal component with Rayleigh distributed multipath. This distribution function [Loo, 1984] is characterized by a mean,  $\mu$ , and standard deviation,  $\sigma$ , for the lognormal part and  $K$  (ratio of unfaded carrier to multipath) for the Rayleigh portion.

The analytical functions (which are not all in closed form) as described above and combined as in (1) have been coded into a program referred to as LMSSMOD. Statistics from this program have been shown to produce results agreeing with experiments. [Barts and Stutzman, 1987; Barts and Stutzman, 1988]

### 3. A Simple Empirical Model for Fade Distributions

The rather cumbersome LMSSMOD computer program is required to evaluate (1) directly. To avoid this a simple empirical model has been developed. It uses (1) and the following fitted functions. For an unshadowed signal, the probability that a fade will be greater than F dB is

$$C_U(F) = e^{-(F+U_1)/U_2} \quad (2a)$$

where

$$U_1 = 0.01 * K^2 + 0.378 * K + 3.98$$

$$U_2 = 331.35 * K^{-2.29}$$

$K$  = carrier-to-multipath ratio [dB]

For a vegetatively shadowed signal, the probability that a fade will be greater than  $F$  dB is

$$C_S(F) = [(50-F)/V_1]^{V_2} \quad (2b)$$

where

$$V_1 = -0.275 * \bar{K} + 0.723 * \mu + 0.336 * \sigma + 56.153$$

$$V_2 = [-0.006 * \bar{K} - 0.008 * \mu + 0.013 * \sigma + 0.103]^{-1}$$

$\bar{K}$  = carrier-to-multipath ratio [dB]  
 $\mu$  = mean of lognormal signal [dB]  
 $\sigma$  = standard deviation of lognormal signal [dB]

Then the percent of distance of travel for which the fade exceeds  $F$  dB is

$$P = 100 * C(F) \quad (3)$$

The empirical model of (1) with (2) and (3) was developed by first finding parameter values of  $K, \mu, \sigma, \bar{K}$ , and  $s$  which lead to LMSSMOD fade distributions that fit to measured data supplied by W. Vogel for balloon and helicopter experiments [Stutzman, 1988]. Then the fit coefficients in (2) were adjusted to obtain a fit of the empirical model to the data. An example is shown in Fig. 1. The typical ranges of parameter values over which the model is valid are:

$$13 \text{ dB} < K < 22 \text{ dB}$$

$$12 \text{ dB} < \bar{K} < 18 \text{ dB}$$

$$-1 \text{ dB} < \mu < -10 \text{ dB}$$

$$0.5 \text{ dB} < \sigma < 3.5 \text{ dB}$$

(4)

#### 4. The Propagation Simulator

A software propagation simulator originally developed by Schmier [1986] simulates MSS signals and predicts primary and secondary fade statistics. A block diagram of the simulator is shown in Fig. 2. This simulator is unique because instead of generating the simulated signal from random number generators, it is generated using universal data sets, derived from experimental data supplied by Vogel, with known statistical properties. By processing Vogel's experimental data, data sets for each signal component having the proper statistical properties can be created. These data sets are scaled to have the proper statistical distribution and recombined to form a composite signal. The output of the simulator simulates a time sequence signal that can be used to produce secondary statistics of average fade duration and of level crossing rate. The simulator output is normalized to produce samples every 0.1 wavelength traveled in order to remove the effect of vehicle speed from the simulation.

The data sets are generated by first separating the experimental data into shadowed and unshadowed data points using a 2

dB below LOS criterion for shadowing. Then the running mean of the data is calculated using a 20 wavelength sliding window. For the shadowed data, this running mean has been found to be lognormally distributed. Subtracting the running mean from the shadowed data on a point by point basis generates a database which has been found to be Rayleigh distributed.

In Schmier's original simulator the unshadowed Rayleigh data set had a uniform phase distribution while the shadowed Rayleigh data set had a bimodal phase distribution centered around 0 and 180 degrees. The current version uses a shadowed Rayleigh data set with a uniform phase. Figure 3 shows that the fade distributions predicted by the analytical model and the simulator are in good agreement.

## 5. Using the Propagation Simulator

A major aspect associated with theoretical, empirical, or simulation modeling is knowledge of the input parameters. The only known work on this portion of the modeling problem is the deterministic path model (DPM) of Smith and Stutzman [1986]. The DPM uses the CCIR Modified Exponential Decay Model (MED) for calculating the attenuation of a signal propagating through foliage. For MSS modeling, roadside foliage is modeled as a semi-infinite block of a known height and setback from the vehicle. Given the elevation angle to the satellite and the bearing angle with respect to the vehicle, simple geometry can be used to calculate the path length through foliage. From the path length, the attenuation of the signal is calculated using the MED. The Deterministic Path Model assumes that the vegetation height and setback are uniformly distributed variables with a minimum and maximum value. The DPM yields the mean and standard deviation of the attenuation, which are estimates of the log normal mean,  $\mu$ , and standard deviation,  $\sigma$ . These values can be used as inputs to drive the simulator. Results of using the DPM to estimate the lognormal mean and standard deviation have shown good agreement with experimental data. Figure 4 shows a fade distribution for data measured by Vogel and Goldhirsh on RT 295 between Baltimore and Washington and the output of the propagation simulator using the DPM to estimate the lognormal mean and standard deviation. Measurements were made for elevation angles of 30, 45, and 60 degrees along the same section of road on both UHF and L-Band. The DPM was used to estimate the lognormal mean and standard deviation for each case with the results used to drive the simulator. The results of the simulator showed good agreement in all cases.

The propagation simulator (as indicated in Fig. 2) also is used to drive the channel simulator developed at Virginia Tech. The channel simulator is used to determine bit error rates of MSS channels for various modulation and coding formats in the presence of propagation effects.

## References

- Barts, R. M., W. L. Stutzman, W. T. Smith, R. S. Schmier, and C. W. Bostian, "Land Mobile Satellite Propagation Modeling," Proceedings of the 1987 IEEE Antennas and Propagation Society International Symposium, vol. I, pp. 20-23, 1987.
- Barts, R. M. and W. L. Stutzman, "Propagation Modeling for Land Mobile Satellite Systems," Proceedings of the Mobile Satellite Conference, pp. 95-100, May 1988.
- Bradley, W. S., and W. L. Stutzman, "Propagation Modeling for Land Mobile Satellite Communications," Virginia Tech Report 85-3 submitted to JPL under NASA Contract 956512, August 1985.
- Goldhirsh, J., and W. J. Vogel, "Propagation Effects by Roadside Trees Measured at UHF and L-band for Mobile Satellite Systems," Proceedings of the Mobile Satellite Conference, pp. 87-94 May 1988.
- Loo, C. "A Statistical Model for a Land Mobile Satellite Link," Proceedings of the 1984 IEEE International Communications Conference, pp. 588-594, 1984.
- Lutz, E., W. Papke, and E. Plochinger, "Land Mobile Satellite Communications-Channel Modeling, Modulation, and Error Control," Proceedings of the 7th Inter. Conf. on Digital Satellite Communications, Munich, Germany, May 1986.
- Rafferty, William, Khaled Dessouky, and Miles Sue, "NASA's Mobile Satellite Development Program," Proceedings of the Mobile Satellite Conference, pp. 11-20, May 1988.
- Schmier, R. G., and C. W. Bostian, "Fade Durations in Satellite-Path Mobile Radio Propagation," Virginia Tech Report No. 86-5 submitted to NASA/JPL under NASA Contract 956512, 1986.
- Smith, W. T., and W. L. Stutzman, "Statistical Modeling for Land Mobile Satellite Communications," Virginia Tech Report No. 86-3 submitted to NASA/JPL under NASA Contract 956512, August 1986.
- Stutzman, W. L., editor, "Mobile Satellite Propagation Measurements and Modeling: A Review of Results for Systems Engineers," Proceedings of the Mobile Satellite Conference, pp. 107-117, May 1988.

P= 92.5% K= 21.5 DB  $\bar{K}$ = 9.9 DB  
MU=-4.8 DB SIGMA=1.7DB

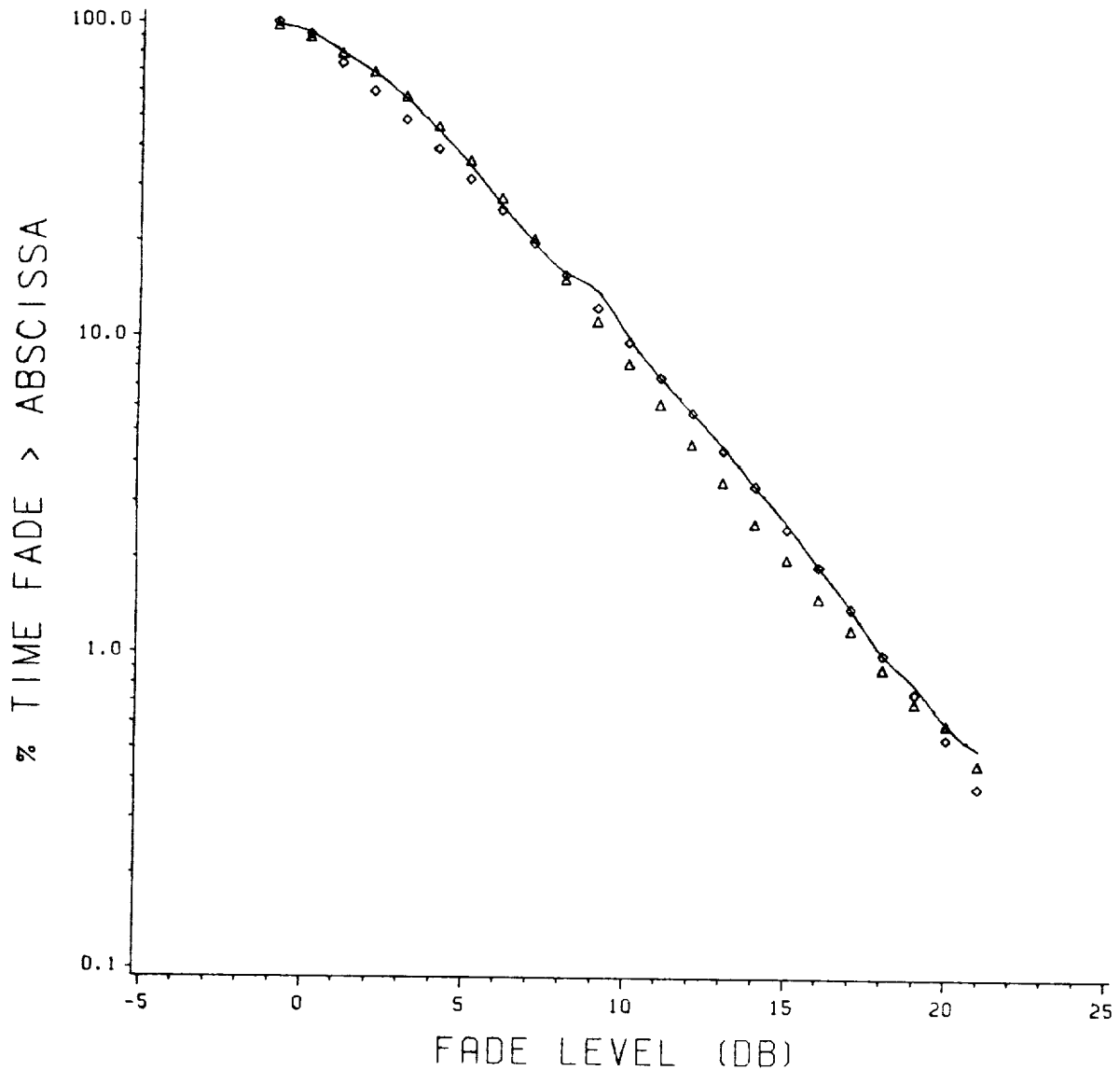

Figure 1. Fade distributions Vogel's 1985 helicopter data [Schmier and Bostian, 1985] (solid curve) compared to predictions of LMSSMOD using (1) (triangles) and to the simple empirical model of (2) (diamonds).

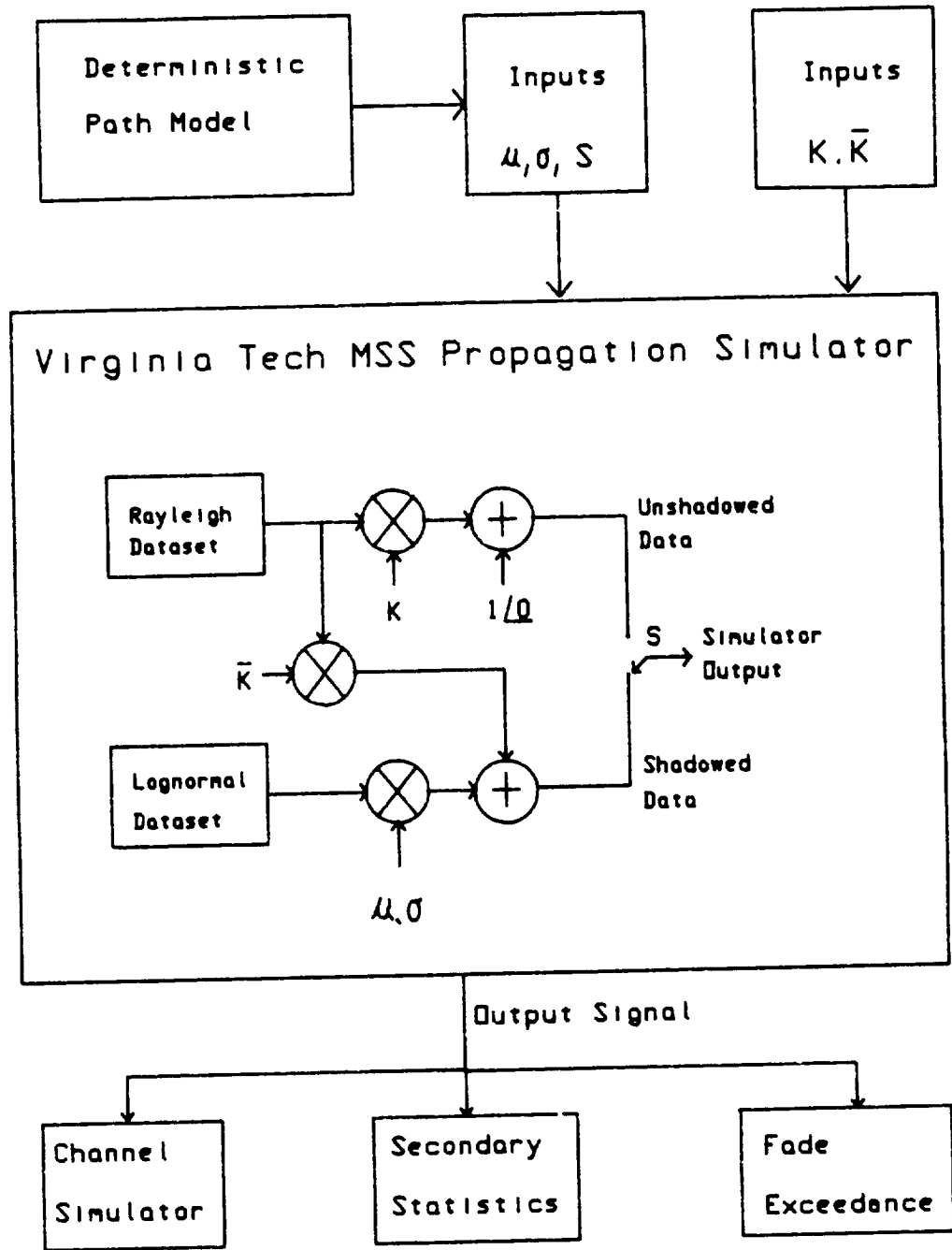

Figure 2. A block diagram of the propagation simulator.

P = 92.5% K = 21.5 DB  $\bar{K}$  = 9.9 DB  
MU = -4.8 DB SIGMA = 1.708

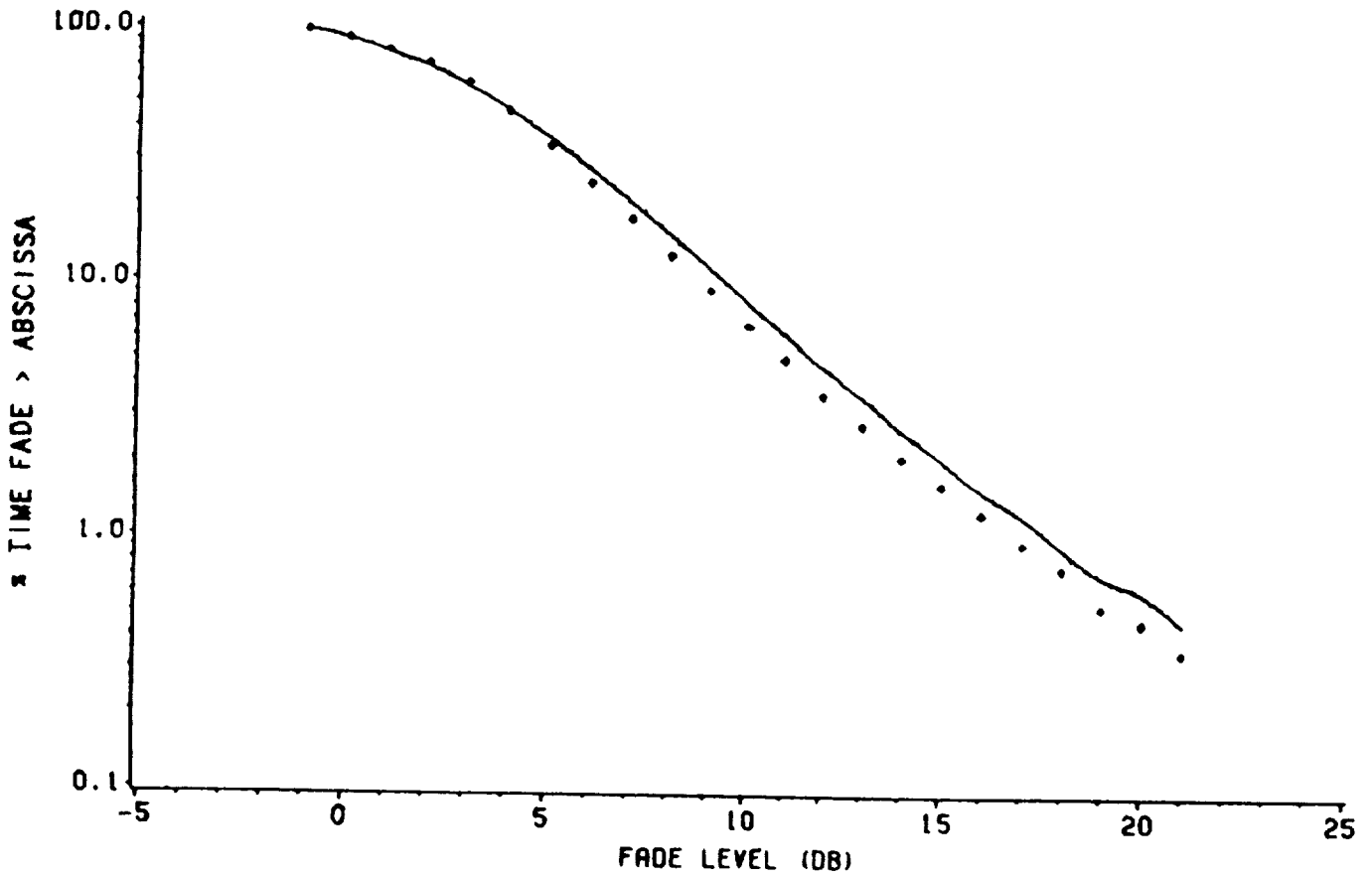

Figure 3. Fade distributions from LMSSMOD using (1) (solid curve) and the propagation simulator (diamonds).



VOGEL/MARYLAND DATA - RT 2959  
L-BAND 30 DEG EL - MEASURED VS SIM2

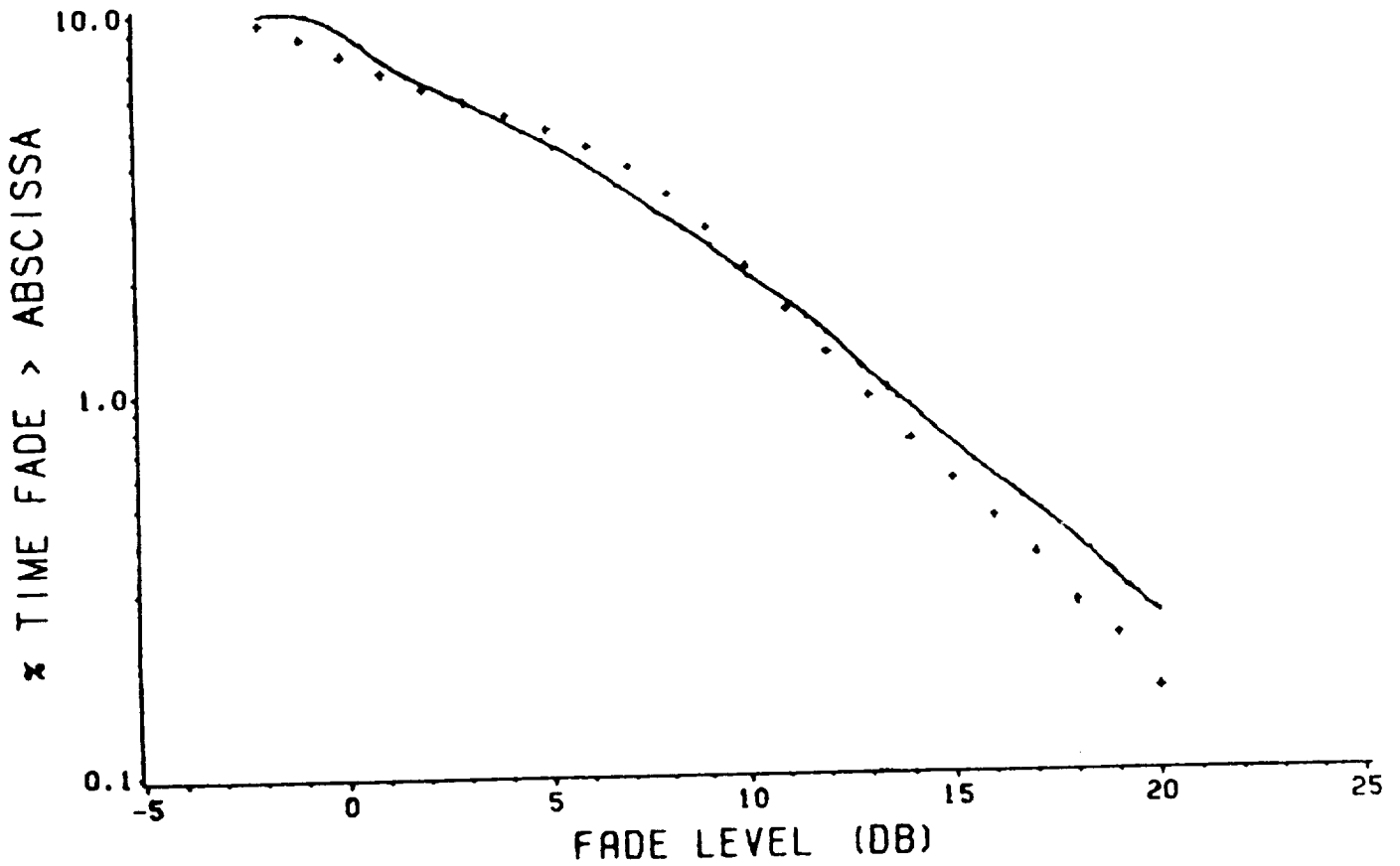

Figure 4. Comparisons between measured helicopter data at L-band [Goldhirsh and Vogel, 1988] (solid curve) and predictions for 30 degrees elevation angle from the propagation simulator using the Deterministic Path Model (crosses).