

A DIGITAL BEACON RECEIVER

Peter D Ransome

Signal Processors Limited
Cambridge Science Park
Milton Road
Cambridge CB4 4GJ
England

Abstract

A digital satellite beacon receiver is described which provides measurement information down to a carrier/noise density ratio approximately 15 dB below that required by a conventional (phase locked loop) design. When the beacon signal fades, accuracy degrades gracefully, and is restored immediately (without hysteresis) on signal recovery, even if the signal has faded into the noise. Benefits of the digital processing approach used include the minimisation of operator adjustments, stability of the phase measuring circuits with time, repeatability between units, and compatibility with equipment not specifically designed for propagation measuring. The receiver has been developed for the European "Olympus" satellite which has CW beacons at 12.5 and 29.7 GHz, and a switched polarisation beacon at 19.8 GHz approximately, but the system can be reconfigured for CW and polarisation-switched beacons at other frequencies.

Introduction

It is of interest to various parties to gather propagation data at microwave frequencies for paths between ground stations and satellites in order to predict the performance of telecommunications systems within current and hitherto unused frequency bands. Conventional high performance satellite beacon receivers are complex (and therefore costly) units needing careful setting-up and maintenance.

At the occurrences of the most interesting(!) propagation events (i.e. deep fades), the performance of conventional phase locked loop receivers degrades catastrophically due to their inherent carrier/noise density threshold. Moreover, as the path recovers, the loop has to either reacquire (implying hysteresis of perhaps 4 dB and inability to measure during this time) or to have previously stored parameters of the unfaded signal in a complex unit, as an aid to reacquisition. The loop bandwidth of the PLL is typically 50 Hz, giving a carrier/noise density ratio (C/No) tracking threshold of 25 to 30 dB.

The beacon receiver developed by Signal Processors Limited (SPL) overcomes the hysteresis problem in addition to maintaining lock down to a point typically 15 dB below the C/No limit for a PLL, whilst gracefully losing accuracy. This is achieved by the elimination of feedback loops, a feedforward architecture being used. Digital processing implies stability, accuracy and repeatability. The tracking of the beacon carrier follows the ideas of (Barton, 1985), by tracking the carrier frequency independently of its phase. Instead of a PLL, the carrier frequency tracking is performed by a digital Fourier Transform Processor, with a box bandwidth of approximately 1 Hz.

System Overview

SPL's digital beacon receiver provides full transmission matrix measurement for signals from polarisation-switched beacons such as those carried by the ESA "Olympus" satellite. R.F. input to the receiver is taken at 70 MHz and output given at 100 Hz, consisting of cartesian digital data to twelve-bit resolution, and accompanying status information.

The receiver is contained in a 3U, 19 inch rack-mounting package, and consists of plug-in modules for R.F. synthesiser, I.F. channel and digitisation, digital signal processing, output interface and system control. The modular design eases the incorporation of special customer requirements. Figure 1 is a block diagram of the receiver.

The analogue stages of the receiver consist of the synthesiser and I.F. channel modules. The synthesiser generates the two local oscillators used by each I.F. channel module. The I.F. module uses a double down-conversion technique to translate the 70MHz receiver input to approximately 15 kHz I.F. at which point the signal is digitised with a 60 kHz sampling rate prior to further processing by the DSP sections of the receiver.

The DSP card removes the final 15 kHz I.F. to produce a (complex number) baseband signal for each received polarisation. Carrier tracking is performed by a spectral analysis of the signals to a resolution of approximately 1 Hz, and the use of an intelligent frequency-tracking algorithm to control a variable frequency digital oscillator to be mixed into the signal path. The sampling rate of the baseband signal can now be lowered (together with the application of a sampling phase correction for a polarisation-switched beacon). The final stage of the DSP work is to normalise all output data components to a phase reference derived from the incoming copolar signal.

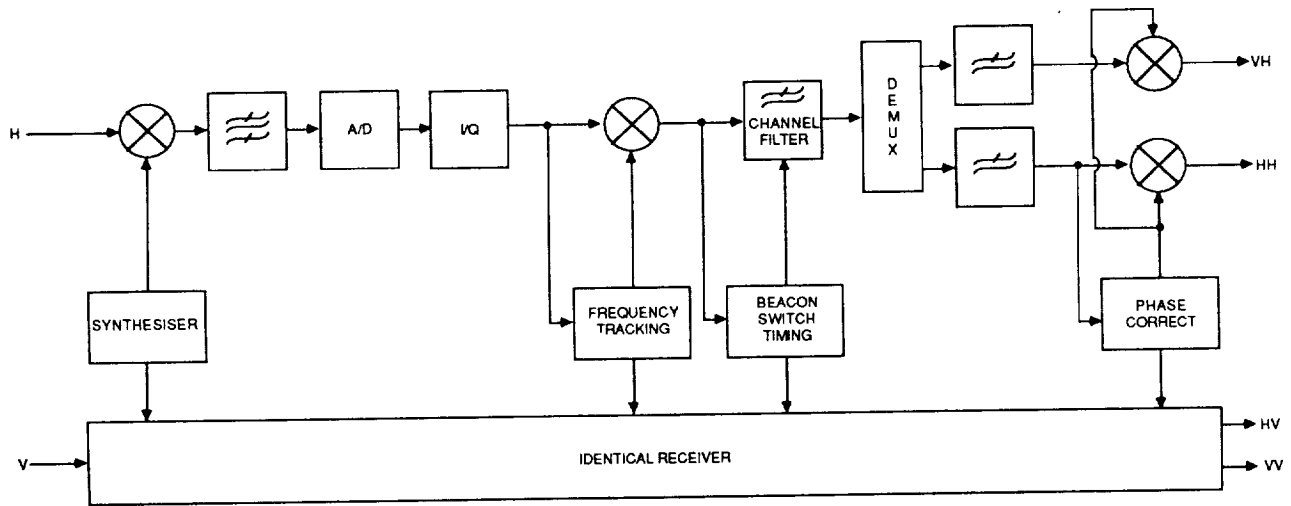

Figure 1. Dual Polarisation Beacon Receiver

The system control module formats the output data to the specified output interface option. Status information is interleaved with this data and also displayed on the receiver front panel. The control module will determine beacon carrier frequency to the accuracy of the station timekeeping, by calibrating its clocks in terms of a station reference frequency that may be provided to the receiver.

Summarised Performance Specification

Input Frequency	70 MHz
C/No Dynamic Range Limits	66 dB (overload) 15 dB (tracking fails)
Carrier Acquisition Level	38 dB C/No
+/- 2 degree Phase Accuracy Point	30 dB C/No
Carrier Phase Measurement Threshold	20 dB C/No
Carrier Freq Tracking Threshold	15 dB C/No
Output Signals	HHi HHq HVi HVq VHi VHq VVi VVq
Output Sample Rate	99.96 Hz (nominal)

Notes:

All figures refer to the 19.8 GHz Olympus Beacon

"C" is the level of the unswitched carrier

Output signal notation refers to: transmit polarisation
receive polarisation
phase measurement axis

The HHq output is non-zero when carrier phase tracking is no longer possible, i.e. below 20 dB C/No

The DBR-1 has been developed for use with the polarisation-switched 19.8 GHz Olympus beacon but is adaptable for use with other beacons on other satellites. When used with other transmitters with no polarisation switching, it should be noted that tracking performance is improved by 6 dB for a given beacon power.

Technical Description

Analogue Front End

The synthesiser reduces the bandwidth required in the digital section of the receiver by removing the bulk of the satellite beacon frequency drift. The synthesiser generates the two local oscillators (L.O.'s) used by the I.F. modules. The 1st L.O. at 59.3 MHz nominal is synthesised and the 2nd L.O. is derived from a temperature compensated crystal oscillator (TCXO) running at 10.685 MHz. Two phase coherent outputs at each frequency are provided, for use when both polarisations of a beacon are being measured (two IF modules fitted).

The I.F. module downconverts the 70 MHz receiver input to approximately 15 kHz I.F. at which point the signal is digitised for processing by the DSP module. A double down-conversion technique is employed, the 1st I.F. at 10.7 MHz and 2nd at 14.928 kHz (sixteen times the Olympus beacon's nominal switch rate). This approach accommodates the input frequency variation whilst allowing a relatively straightforward LC filter at 70 MHz to provide adequate front end selectivity. The 10.7 MHz I.F. is filtered by a custom designed crystal filter with bandwidth (-1 dB) of 15 kHz. This filter also provides adequate rejection of polarisation switching sidebands which can alias onto the carrier after digitisation. The ADC is a self-calibrating 14-bit successive approximation type, sampling at 59.712 kHz (four times the final I.F.).

The R.F. input and L.O. signals are connected via coaxial inserts through the backplane connectors. Milled aluminium boxes provide shielding of the analogue sections of the cards.

Digital Processing

The final I.F. is locked at one quarter of the ADC sampling rate, so its removal is simple (in the digital domain), to leave a complex data stream for each received polarisation. Carrier frequency tracking is accomplished by spectral analysis of the input signal in one received polarisation channel. An intelligent tracking algorithm allows frequency "boxes" of about 1 Hz width (a width well matched to the phase-noisy spectrum of signals at this point). Frequency tracking of a CW beacon can be maintained down to a C/No of 9 dB, and of a polarisation-switched beacon down to 15 dB (a higher figure since the sideband power is rejected in the tracking algorithm). The C/No at which tracking stops is operator-selectable, and the receiver holds its estimate of beacon carrier frequency at that point and waits for the signal level to recover, reacquiring with no hysteresis after short term "deep fades".

The carrier is removed to leave signals ready for polarisation tracking (analogous to symbol timing recovery). This is performed by decimating the sample rate to four times the beacon switch rate, and dumping the samples sequentially into four integrators. Analysis of the bin contents provides an indication of the phase of the (polarisation) modulation (if the C/No is high enough). Having determined the sampling points, a variable group delay filter provides correct sample phase (on a polarised signal), and a channel filter provides correct attenuation of switching sidebands. Finally the signals are decimated to a sample rate of approximately 100 Hz, normalised in phase to the HHi component (if C/No is above 20 dB), formatted for the output interface, and sent.

Output Data Format

The twelve-bit output data wordlength and 100 Hz sampling rate have been agreed between OPEX working groups WG1 (Hardware), and WG2 (Data Pre-processing). The intention is that information of a 30-40 Hz bandwidth is to be retained during conditions of low fading in order to investigate scintillation effects, while the bandwidth will be dropped by a preprocessor during deep fades.

Operation

A serial link is provided for connection to a terminal used to set up receiver parameters and optionally to monitor status (the status information is also sent out with the output data). Receiver front panel display is minimal, consisting of lock indication and machine function/error status.

Trials

The receiver tracking performance has been developed with the aid of computer simulation. Field trials are scheduled for July 1988 at an open-air test site at the Rutherford Appleton Laboratory, Chilton, England. The site provides transmission and reception at 20 GHz, and test signals of realistic quality.

Acknowledgments

The DBR-1 receiver development has been funded in part by the European Space Agency (European Space Research and Technology Centre, Noordwijk, Netherlands) and the Science and Engineering Research Council (Rutherford Appleton Laboratory, Chilton, England. RAL will also provide field test facilities.)

References

Barton, S.K., "Section 6.4 : Alternative Digital Receivers" in OPEX Handbook for Beacon Receiver Design, Issue 1, January 1985