

## ANIMALS IN SPACE

Angela White

Animals have always been important to the space program. The United States flew monkeys in rockets between 1948 and 1952, ten years before the first orbit of the Earth by a man. The Soviet Union used dogs in their space program--a Soviet dog orbited the Earth in Sputnik II for a week in 1957. Monkeys were tested in the early years of NASA to determine whether it was safe for humans to fly into space. After Yuri Gagarin of the USSR became the first man to orbit the Earth, space animals were all but dropped in favor of using humans. However, recently, more animals are going into space, mainly for research purposes. On Spacelab 3 (SL-3), 26 animals experienced weightlessness and were studied thoroughly afterward, yielding valuable data. Animals are a valuable part of the space program and NASA should support sending more animals in the future.

The history of animals in space is not nearly complete. Such a history would show how well animals have been treated in the space program. Certain activist groups have advocated the total elimination of animal use in research, including space research, because of reports of inhumanity in too many research laboratories. A ban on animal use in research would decrease the number of animals killed and tortured each year in the nation. Such a ban, however, would severely cripple the space program. So far, NASA has an excellent record of humane treatment of animals. For example, 24 rats and two squirrel monkeys were part of the last Spacelab mission, SL-3. Originally, the animals were sent only as a test of the research animal holding facility, or RAHF (fig. 1).

Fortunately, the mission produced much more useful data than expected. It was discovered that the cage was an acceptable, nonstressful environment. One indication that the RAHFs were nonstressful environments was the growth rate of the rats. Mission rats grew slightly less than rats in similar housing on the ground, and those rats grew less than rats in vivarium cages. However, according to Christopher Schatte, project scientist of the SL-3 life sciences payload, weight loss was probably caused by reduced energy requirements owing to microgravity, and also adaptation to a new environment. Another indication of low stress levels was the fact that the weights of certain organs, such as the spleen, brain, and heart, were within normal limits of variation. Other indications of chronic stress, such as adrenal hypertrophy and liver atrophy were not observed.

The monkeys were not analyzed postflight as thoroughly as the rats were, so data on life processes are not available for them. However, it was shown that squirrel monkeys will probably be acceptable in studies of space-adaptation syndrome, or space sickness. One monkey maintained normal eating behavior, but one showed decreased food intake during the first four days of the mission, then returned to normal eating behavior in the last three days. Videotape records of behavior showed decreased activity, followed by normal activity. Although no actual sickness was observed, these results are consistent with symptoms of sickness in monkeys centrifuged at 1.5 g (1.5 times normal gravity) and with human space sickness. No post-

flight abnormalities were observed. It is hoped that the squirrel monkey will be a good model for future studies.

Although space research has been humane, some people are concerned about the necessity of animal research. If it is not absolutely necessary, then it should not be conducted. Animals are necessary to the space program and have been from the beginning of the program. Some experiments are performed on animals that could not be performed on humans.

The rats on SL-3 are an example of vital studies possible only on animals. In order for the researchers to obtain data, the rats were sacrificed as soon as was possible after landing. (There was a 12-hr gap between landing and sacrifice, due to a late change in landing site.) The detailed studies made of conditions such as bone and muscle loss would not be possible on humans.

Future payloads of animals will be necessary in order to provide answers not available from human studies. Spacelab 4, renamed Spacelab Life Sciences 1 (SLS-1), will carry the newly modified RAHF. (The RAHF was redesigned after it allowed particulates to escape on SL-3.) The RAHF will carry no animals, but will be tested to see if it allows particles to escape. SLS-1 will also carry jellyfish for observations not possible on mammals, such as graviceptor formation, graviceptor function, and swimming abilities. Graviceptors of jellyfish are easily observable, unlike those of humans. Studies of graviceptors and swimming behavior could give clues as to how graviceptors work in humans. Rats will go up on SLS-1; not in the RAHF, but in the animal enclosure module, or AEM (fig. 2). It is bigger than a single RAHF unit and holds five rats in the same area, or ten rats total in two areas. It has gone up on two previous missions and hopefully will go up on several others. Catheters attached to blood vessels near the heart in the rats will provide blood-flow data difficult, if not impossible, to obtain in humans. The rats will also be sacrificed postflight.

On a future Spacelab mission, Spacelab Japan (SL-J), frog embryos will be fertilized in space in the frog embryology unit (FEU--fig. 3). Knowledge of embryology in space has potential applications in future projects, especially the Space Station. However, until the station is built, studies of embryology must be limited to animal embryos that develop quickly, which is necessary in a seven-to-ten-day shuttle flight. The rapid development of frog embryos makes this experiment possible, which would be impossible with humans.

No matter how humane animal experiments are or how much data can be obtained which are unavailable from humans, all animal experiments would be useless if their results were not applicable to humans in useful ways. Nonhuman (animal) life processes are appropriate models for human life processes, and useful data can be obtained from them. As indicated above, on the next Spacelab mission, SLS-1, rats and jellyfish will be part of the payload. The jellyfish are included in order to study their graviceptors and methods of swimming in space. This is applicable to humans because of the lack of information we have on human graviceptors. If the mechanism of jellyfish graviceptors is studied, it might provide some clues to human graviceptors and how they work.

The rats will be monitored internally by implants in a flap in their backs. (The rats show no evidence of noticing these after about one day.) Information from the monitoring, such as blood flow, blood chemistry and rate of metabolism will provide more clues as to how the human body adapts to space, in good ways as well as bad. Postflight dissection will yield information on the inner ear, bone, bone marrow, spleen, muscles, and blood. Even the frogs on SL-J will provide embryology information that will be applicable to humans. Stages of development in frog embryos which are gravity-sensitive will be examined and analyzed. The data will then be compared with current knowledge of human embryos. Future flights such as these will provide much useful data.

SL-3 has already produced results and data from the rat and monkey experiments, most of which will be applicable to humans, but some of which will have to be interpreted before being of use. The decrease in production of gamma interferon by spleen cells cultured postflight is one of several changes that were previously linked to stress and are now linked to the microgravity environment. This particular change has not been explained and may be, like the other hematology, immunology, and blood chemistry results, invalid, since they would be most susceptible to the 12-hr gap between landing and sample acquisition.

However, there are some results that are valid and can be explained only by speculation at this time. ("Speculations" made here are mainly those of Christopher Schatte (1986).) The overall heart rate of the rats decreased slightly from preflight measurements, although it was steady. This probably comes from the reduced activity of the rats. A more important observation was the fact that body temperature rhythms disassociated from cardiac rhythms and began to free run. When these two rhythms disassociate, it can produce adverse effects, such as jet lag. Further experiments will be needed to test rhythm disassociation and determine its effects.

Other areas where the rats showed changes possibly applicable to humans were muscles, bones, and growth hormone production. "Growth" hormone is involved in maintenance of muscles and bones, which showed deterioration. Flight animals produced less growth hormone than controls. This reduction could have caused the deterioration in muscles and bones. If this is true in humans, hormone therapy and exercise might counteract those effects. Loss of mass in muscles was evident, especially in anti-gravity muscles. There were two groups of rats--mature rats and immature, growing rats. The immature rats lost less muscle mass, but since they were supposed to be growing, there was a greater difference in weight between the flight and control immature rats than between the flight and control mature ones. Loss of mass tended to occur because of cell shrinkage rather than self-destruction. This could explain why no apparent long-term damage has been observed in humans. The main changes in bone were not in mass; they were increased fragility, reduced bone-plate growth activity, and shifting of bone mineral from lower to higher specific gravity fractions. Increased bone demineralization, usually considered an indicator of decreased bone integrity, did not occur in significant amounts. This integrity indicator may have to be reassessed, since an increase in bone fragility did occur. A decrease in a certain polypeptide (osteocalcin) might be responsible, since decreases correlated with mineral loss. If it is, therapy might be possible. The little demineralization that did occur was found even in bones that did not play a significant anti-gravity role. This indicates

that a systemic factor might be involved. There is much to be learned from SL-3, if we can discover what the results mean. However, the results that we do understand are probably applicable to humans.

Animals are indispensable to the space program. Their continued use could have many significant results. Those who are opposed to using animals in space should remember that space animals are treated humanely; they are necessary because results can be obtained from them that would be unobtainable from humans; and results from animal experiments can be applied to human systems. Therefore, NASA should continue to use animals in space research.

#### BIBLIOGRAPHY

- P. X. Callahan, et al., *Ames Research Center Life Sciences Payload: Overview of Results of a Spaceflight of 24 Rats and 2 Monkeys*. AIAA Paper 86-0583, AIAA 24th Aerospace Sciences Meeting 1986, American Institute of Aeronautics and Astronautics, New York, 1986.
- C. Kelly Hill (Editor), *Spacelab Mission 3 Experiment Descriptions*, NASA TM-82502, Marshall Space Flight Center, Alabama, 1982.
- Management and Technical Services Company, *Ames Research Center Spacelab Life Sciences-1 Payload Integrated Experiment Requirements Document*, Doc. No. ADE-82-50-002 Rev-1, Moffett Field, CA, 1986.
- C. Schatte, R. Grindelnd, P. Callahan, G. Funk, W. Lencki, and W. Berry, *Animal Studies on Spacelab-3*, NASA Technical Memorandum 88212, National Aeronautics and Space Administration, Moffett Field, CA, 1986.
- C. Schatte, Significance of the SL-3 Results, Unpublished (1986).
- SLS-1 Rodent Experiments Science Working Group, Meeting Report (Untitled), Ames Research Center--Life Sciences Flight Experiments Projects Office, 1986.

ORIGINAL PAGE IS  
OF POOR QUALITY

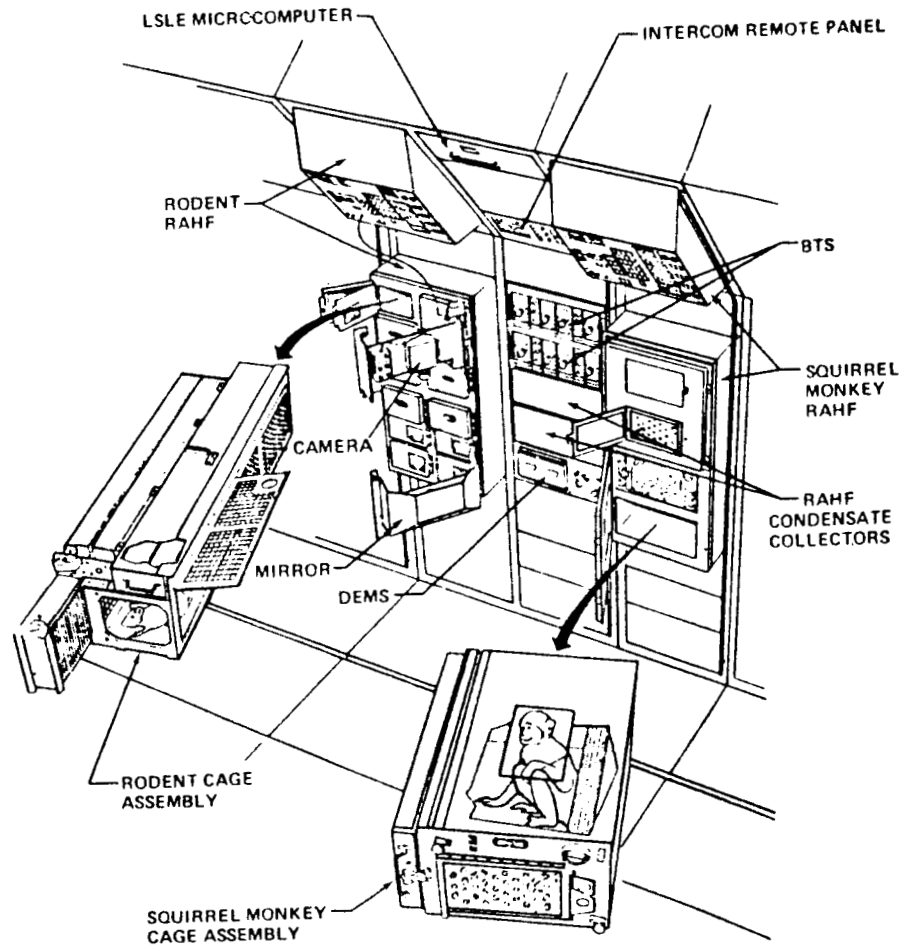

Figure 1.- The research animal holding facility (RAHF).

ORIGINAL PAGE IS  
OF POOR QUALITY

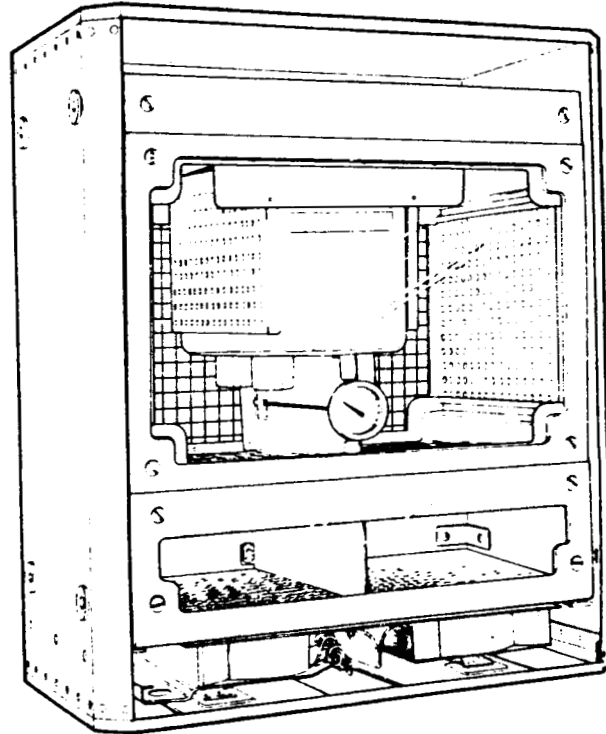

Figure 2.- Animal enclosure module.

ORIGINAL PAGE IS  
OF POOR QUALITY

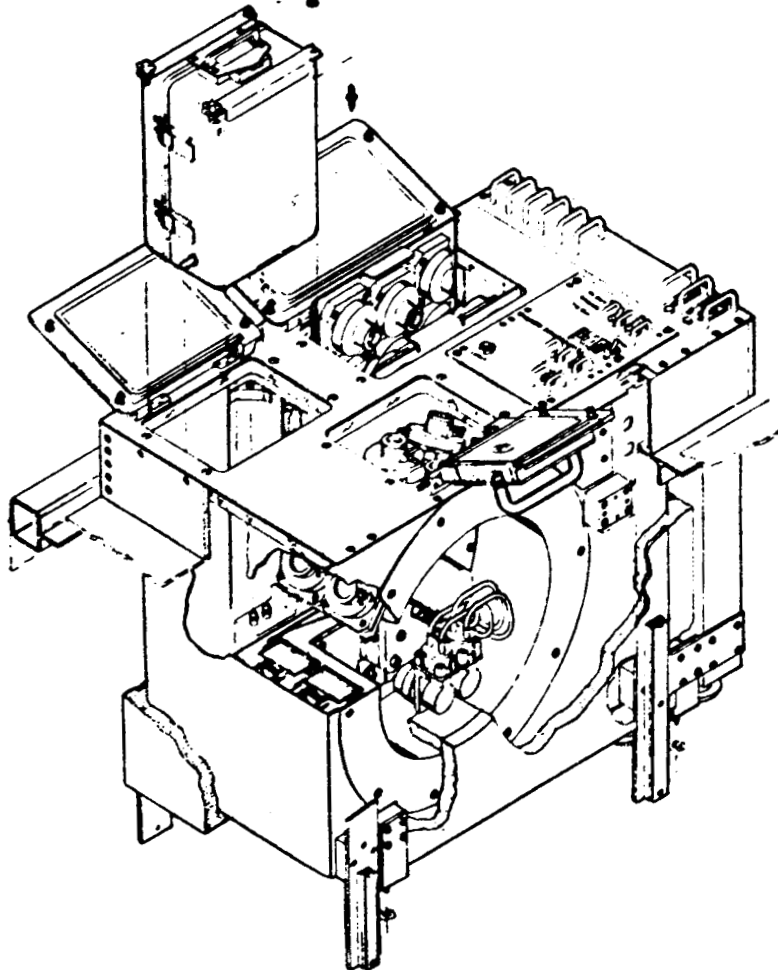

Figure 3.- Frog embryology unit.