

Effect of Micrometeoroid and Space Debris Impacts on the Space Station Freedom Solar Array Surfaces

(NASA-TM-102287) EFFECT OF MICROMETEORID
AND SPACE DEBRIS IMPACTS ON THE SPACE
STATION FREEDOM SOLAR ARRAY SURFACES (NASA.
Lewis Research Center) 12 p CSCL 22B

N89-26035

Unclas

G3/18 0219606

Henry K. Nagra
Lewis Research Center
Cleveland, Ohio

Prepared for the
1989 Spring Meeting of the Materials Research Society
San Diego, California, April 24-29, 1989



EFFECT OF MICROMETEOROID AND SPACE DEBRIS IMPACTS ON THE SPACE STATION FREEDOM SOLAR ARRAY SURFACES

Henry K. Nagra

National Aeronautics and Space Administration

Lewis Research Center

Cleveland, Ohio 44135

ABSTRACT

Both solar and antisolar surfaces of the Space Station Freedom solar arrays are vulnerable to micrometeoroid and space debris impacts. Impacts on the solar surface result in damage to the active area of the solar cell and a corresponding reduction in generated power. Impacts on the antisolar surface could result in damage to the circuit which interconnects the cells which in turn may produce open circuit strings or panels.

This paper presents an evaluation of the power degradation resulting from the impacts of micrometeoroid and space debris on the solar surface of the array blanket. Moreover, given a particle diameter that could damage the circuit interconnecting the cells, this paper computes the probability of an open circuit panel, and ultimately the probability that the solar array blanket will meet the power requirement over the design lifetime.

INTRODUCTION

The micrometeoroid and orbital space debris environment of the low earth orbits consists of hypervelocity particles of various mass, diameter, and velocity. On impact with a spacecraft structure, the resulting damage will depend primarily on the above parameters as well as the impacted material. While the micrometeoroid environment is natural, the debris environment is man made. Micrometeoroids have an average density and velocity of 0.5 g/cm³ and 20 km/sec respectively whereas space debris average density and velocity is 2.8 g/cm³ and 9 to 10 km/sec depending on the altitude. Micrometeoroid

and debris (M&D) flux can be calculated using the M&D flux models reported in SSP 30425 the "Space Station Program Natural Environment Definition for Design" document (Ref. 1) and in Ref. 2. Given a particle size that damages a surface according to a damage criterion (such as severe degradation in mechanical properties or failure), the average flux for particles of this diameter or larger can be calculated using the M&D flux models.

THE MICROMETEOROID AND ORBITAL DEBRIS FLUX MODELS

The micrometeoroid and orbital debris flux models currently baselined for the Space Station Freedom are given by the following (Ref. 1),

Micrometeoroid

$$\text{Log}_{10}(F_m) = -14.37 - 1.213 \times \text{Log}_{10}(m) \quad (1)$$

for $10^{-6} < m < 1$ gm

$$\text{Log}_{10}(F_m) = -14.34 - 1.584 \times \text{Log}_{10}(m) - .063 \times \text{Log}_{10}(m)^2 \quad (2)$$

for $10^{-12} < m < 10^{-6}$ gm

Orbital Debris

$$\text{Log}_{10}(F_d) = -2.42 \times \text{Log}_{10}(D) - 5.82 \quad (3)$$

at 400 km altitude

$$\text{Log}_{10}(F_d) = -2.52 \times \text{Log}_{10}(D) - 5.46 \quad (4)$$

at 500 km altitude

where F_m (#/m²-sec) and F_d (#/m²-yr) are the micrometeoroid and debris flux respectively, m is the micrometeoroid mass (gm), and D is the debris diameter (cm). The mass and the diameter of a projectile can be related by assuming the impacting particles to be spherical. Such relation is given by

$$D=(6m/\pi\rho p)^{1/3} \quad (5)$$

Figure 1 shows the micrometeoroid and space debris flux models. The micrometeoroid flux obtained from equation (1) or (2) should be multiplied by the Earth shielding and focusing factors. The first factor takes into account the shielding that Earth provides against micrometeoroid streams and ranges between 0.5 above the Earth atmosphere to 1.0 in deep space. The second factor accounts for the gravitational effect of the Earth on the meteoroid trajectory and ranges from 1.0 above the atmosphere to 0.568 in deep space. The shielding (SF) and focusing (Ge) factors are given by the following respective relations,

$$SF=(\cos(\arcsin(R_e/(R_e+H)))+1)/2 \quad (6)$$

$$Ge=0.568+0.432x(R_e/r) \quad (7)$$

where R_e is the Earth radius+100 km, H is the altitude above the Earth atmosphere (taken as 100 km), and r is the radius of the orbit in km (Ref. 1).

The micrometeoroid and orbital debris flux depends on the particle velocity. For these calculations, the average velocities for the debris (9–10 km/sec) and micrometeoroid (20 km/sec) will be used. Moreover, space debris flux depends on the angles that an orbiting debris makes with and the spacecraft surface normal and velocity vector. This effect is taken into account by multiplying the flux of debris by a flux factor (FF) averaged over one orbit. The flux factor averaging was necessary because the solar array velocity vector varies as the solar surface tracks the sun (Ref. 2).

The orbital debris flux model is being reviewed for updates that address the solar activity, the launch activity, the orbit inclination and altitude. The updated orbital debris model, which is in the process of being baselined by the Space Station Freedom Program, predicts a flux that increases rather than being constant with time. Preliminary calculation of debris flux using the new debris model shows significant increase of flux for the small diameter particle as compared to the older debris model. This is due to the inclusion of the solar activity 13 months smoothed $F_{10.7}$ value, the debris growth rate based on future global launch predictions and the orbit al-

titude and inclination functions in the flux calculation (Ref. 3).

DESCRIPTION OF THE SPACE STATION FREEDOM SOLAR ARRAY

The space station solar array consists of two photovoltaic blankets for power generation, a mast for blankets deployment and support, a mast canister for mast stowage, two blanket boxes for blanket stowage during launch, and a deployment mechanism for on-orbit array deployment. Each blanket consists of active solar cell panels structurally connected by hinge pins. The solar cells on a panel are interconnected by photoetched copper circuit encapsulated between two Kapton® layers. The cells are welded to the copper pads and attached to the Kapton® substrate by an adhesive. The space station solar array is illustrated in Figure 2 whereas Figure 3 shows the solar and antisolar surfaces of an 8x8 cm solar cell string in more details (Ref. 4).

Micrometeoroid and debris impacts on the solar surface of the array result in damaged/inactive areas on the solar cells which reduce the generated current and power from the cells. Impacts of certain particle diameter on the antisolar surface of the solar array could damage the polymeric substrate, whereas impacts of larger diameter particles could penetrate the substrate and damage the photoetched copper circuit. This could result in open strings or panels which reduce the power delivered by the array. Impacts on the solar array mast depending on the particle size could damage the S-glass epoxy longeron and perhaps induce structural instability in the array. An experimental effort is underway at the Hypervelocity Impact Research Laboratory (HIRL) at Johnson Space Center to determine the damage induced by different projectile diameters on the mast longeron and solar cell samples.

Analyses are presented in this paper to predict the total damage induced by the micrometeoroid and space debris environment on the solar surface of the array and also to determine, given a circuit damaging particle size, the probability that a blanket meets the power requirement over its design lifetime.

¹ Registered Trademark of DuPont, Inc.

ANALYSIS

Solar surface

In order to calculate the total damage induced by the micrometeoroid and debris impacts on the solar surface of the array, it is necessary to calculate a differential flux for particles of diameter between D and $D+dD$ from the cumulative flux models, which then can be used in conjunction with a damage correlation to calculate the differential damage. The latter is then integrated over the particle diameter range prescribed by the micrometeoroid and debris flux to obtain the cumulative damage. In this calculation, the damage correlation is assumed the same for all particle diameters. This means that all impacting particles cause an impact damage to the solar cell as prescribed by the damage correlation. The differential flux is given by the following,

$$dF(D_{mid})=F(D+dD)-F(D) \quad (8)$$

where D_{mid} is the midpoint of the diameter interval $[D, D+dD]$, $dF(D_{mid})$ is the differential flux, $F(D+dD)$ is the flux evaluated at the diameter $D+dD$ and $F(D)$ is the flux evaluated at diameter D . The damage correlation which relates the diameter of the damaged area as a function of the impacting particle diameter is obtained from Ref. 5 and dates back to Apollo missions. The damaged area induced by D_{mid} is given by,

$$DD(D_{mid})=(13 \times 0.53 \times \rho_p^{1/2} \times D_{mid} \times v_p^{0.67})^2 \times \pi / 4 \times dF(D_{mid}) \quad (9)$$

where ρ_p and v_p are the projectile density (g/cm^3) and velocity (km/sec), and DD is the differential damage caused by $dF(D_{mid})$. The total damage induced by the particle range described by the flux model can be obtained by integration of the differential damage over the particle diameter range and is given by,

$$CD = \int DD(D_{mid}) \quad (10)$$

where CD is the cumulative damage induced by particles of all diameters as prescribed in the flux models for micrometeoroid and space debris. In this calculation, dF was multiplied by the SF and Ge fac-

tors evaluated at 400 and 500 km altitudes. Figure 4 shows the flow of calculation just described.

Antisolar Surface

Impacts on the blanket substrate induce damage which depends on the particle size and velocity. The induced damage varies from pinholes in the protective coating of the blanket, pinholes in the blanket itself, to possible damage of the photo-etched copper circuit (which could render the circuit open) encapsulated between the Kapton® layers of the panels. In this paper, the probability of success of a blanket which is defined as the probability that a blanket meets the power requirement at the end of design lifetime is computed given a particle diameter that could damage the copper circuit.

To perform this calculation, the probability of no open panel is first calculated. The calculation assumed that the damaging particle diameter is 20 times smaller than the copper circuit width shown in Figure 3. The probability of no open panel caused by impacts is given by (Ref. 6),

$$P_{\text{circuit}} = \left\{ [1 - (1 - \exp(-A_1 FT))^2]^6 [1 - (1 - \exp(-A_2 FT)) \times (1 - \exp(-A_2 FT))] \times (1 - \exp(-2A_3 FT)) + \exp(-2A_3 FT) \right\}^{50} \quad (11)$$

where A_1 , A_2 , A_2 , and A_3 are the respective areas shown in Figure 3, F is the flux of particle of diameter D or larger, T is the design time in years. The exponent 6 corresponds to the six areas of type A_1 per string, and the exponent 50 corresponds to 50 strings per one circuit (defined as two panels in series). Using the binomial cumulative probability distribution, the probability of success of the blanket, which is defined as the probability of success of at least 40 string at the end of design lifetime from 41 strings at the beginning of lifetime, is then calculated from equation 12 given by (as in Ref. 6).

$$P_{\text{blanket}} = \sum_{x=k}^n \frac{n!}{n!(n-x)!} P_{\text{circuit}}^x (1 - P_{\text{circuit}})^{(n-x)} \quad (12)$$

Panel pairs were considered to be in parallel because every two panels are protected by a blocking diode which, upon failure of a circuit, the blocking diode protects the rest of the blanket. Figure 5

shows the flow of calculation of the probability of success of the blanket.

RESULTS

Solar Surface

Table I illustrates the results of the damage calculation on the solar surface of the array. Two calculations were made for ten and four years of design lifetime respectively. Using the micrometeoroid and orbital debris models, the damaged area per m² of exposed area was calculated for a particle diameter ranging from .0001 to 1.0 cm for both the micrometeoroid and debris models. The contribution to the cumulative damage was negligible for particle diameter greater than 1 cm. Using a packing factor of 0.7 (or 70% of the exposed area is populated with active solar cells), the results were converted into % degradation or % oversizing factor needed to ensure the required deliverable power from the array. These factors are displayed in table I as well.

The assumption that the damage correlation used in equation 9 being the same across the range of the particle diameter prescribed by the models is not absolutely true. Penetrating particles may cause damage that is more or less severe than what the correlation predicts. Therefore, there is some uncertainty associated with the results due to this assumption. As a comparison, it is worth noting that the degradation factor associated with the M&D environment and used to size the solar array is 1% over four years of design lifetime.

Antisolar Surface

Figure 6 shows the results of the probability of success of the blanket as a function of the number of impacts/m²-year (for both micrometeoroid and orbital debris) that are damaging to the photo-etched circuit. Since the circuit width in the panel is approximately .4 cm, and assuming that the impacting particle required to damage the photoetched circuit is 20 times smaller in diameter than the circuit width (which result in .02 cm particle), the expected flux from the M&D models is given in table II for 400 and 500 km altitudes and 4 and 10 years lifetimes. From table II and Figure 6, one sees that the

probability of success of the solar array blanket is nearly 1.0. This can easily be explained as due to the high level of redundancy in the circuitry and the welding pads of the circuit to the solar cells interconnects.

The assumption regarding the particle diameter that damages the circuit being 20 times smaller than the circuit width is considered reasonable and conservative. Light gas gun impact testing (as described in Ref. 7) on the front of the solar cell samples showed a damage diameter approximately seven times the projectile diameter of 0.5 mm. Impacts of hypervelocity projectiles that are plasma-drag-accelerated on the rear side of OLYMPUS array structure designed for the L-SAT spacecraft (Ref. 8) showed crater diameter approximately five times larger than the projectile diameter of .0114 cm (Ref. 9). The copper circuit of the OLYMPUS array according to Ref. 8 is embedded into the structure and is separated from the solar cells by a Kapton® layer which makes it similar to the Space Station solar array structure.

As was previously mentioned, damage testing is underway at the JSC Hypervelocity Impact Facility to determine the damage induced by particles of diameter of - 400 μm on the front and back of two solar cells adhered on polymeric Kapton® substrates of different thicknesses. It is hoped that these tests help determine the approximate particle diameter that could damage the copper photo-etched interconnecting circuit of the solar cells.

CONCLUDING REMARKS

In this paper, the micrometeoroid and debris models baselined for the Space Station Freedom program were used to calculate the expected degradation of performance of the solar array due to impacts of micrometeoroid and orbital debris on its solar surface. Moreover, the models were used to compute the probability of success of a blanket given a particle size that could damage the interconnecting circuit.

More detailed modeling that considers direction of impacts, secondary ejecta effect, orbit geometry and velocity distribution of micrometeoroid and space debris is necessary. Prediction of the effects of

such an environment on the solar array and other power system surfaces is crucial to the design, especially in the increasing orbital debris environment. Therefore, further detailed modeling is recommended to be pursued in order to answer the concerns related to the M&D environmental effects.

ACKNOWLEDGMENT

The author wishes to acknowledge the reviewers of this paper, D. J. Hoffman from the System Engineering and Analysis Branch, D. C. Briehl from the PV Module Integration Branch, and W. M. Bartlett from the Solar Array Branch for their time and constructive comments.

REFERENCES

1. "Space Station Program Natural Environment Definition for Design." Space Station Freedom Program Office, SSP 30425
2. Elfer N., and Kovacevic G., "Design for Space Debris Protection." in Man's Permanent Presence in Space. AIAA, New York, 1985.
3. Proposed Change to the "Space Station Natural Environment Definition for Design." Space Station Freedom Program Office, SSP 30425, February, 1989.
4. Elms R. V., Miyagi K., Winslow C. A., "Space Station Solar Array Design and Development," Proceedings of the 23rd Intersociety Energy Conversion Engineering Conference. Denver, Colorado, July 31-August 5, 1988, pp. 589-594
5. "Secondary Impact Hazard Assessment," Final Report. Prepared for the Solar System Exploration Division of the Johnson Space Center, Eagle Engineering, Houston, Texas, June 1986. pp. 231
6. Nahra H. K., "Assessment of the Effects of Space Debris and Meteoroids Environment on the Space Station Solar Array Assembly," NASA Technical Memorandum 101315, Prepared for the 20th Photovoltaic Specialists Conference. Sponsored by the Institute of Electrical and Electronics Engineers. Las Vegas, Nevada, September 26-30, 1988.
7. Schneider E., "Micrometeorite Impacts on Solar Panels", Proceedings of the 5th European Symposium: Photovoltaic Generators in Space. Scheveningen, The Netherlands, September 30, 1986, pp. 171-174
8. Gerlach L., Marks G. W., Quittner E., Renshall J., Zwanenburg R., "The Design of the L-SAT Solar Array," Proceedings of the 3rd European Symposium: Photovoltaic Generators in Space. Bath, May 4-6, 1982, pp. 241-255, (ESA SP-173, June, 1982)
9. Weishaupt U., Kuczera H., Rott M., "Micrometeorite Exposure of Solar Arrays," Proceedings of the 5th European Symposium: Photovoltaic Generators in Space. Scheveningen, The Netherlands, September 30, 1986, pp. 175-180.

TABLE I		
Altitude (km)	Damage (cm ² /m ²) 10 years	Damage 4 years
500	39.32	15.74
400	15.8	6.3
	Degradation % 10 years	Degradation % 4 years
500	0.56	0.23
400	0.23	0.09

Table I. Results of the Damage Calculation on the Solar Surface of the Array

TABLE II				
Particle diameter (cm)	Altitude (km)	Flux/year (#/m ²)	Flux over	
			4 years	10 years
			(#/m ²)	
0.02	400	0.361	1.45	3.61
0.02	500	0.44	1.77	4.4

Table II. Flux Prediction of the Micrometeoroid and Space Debris Models for Particle Diameter of 0.02 cm

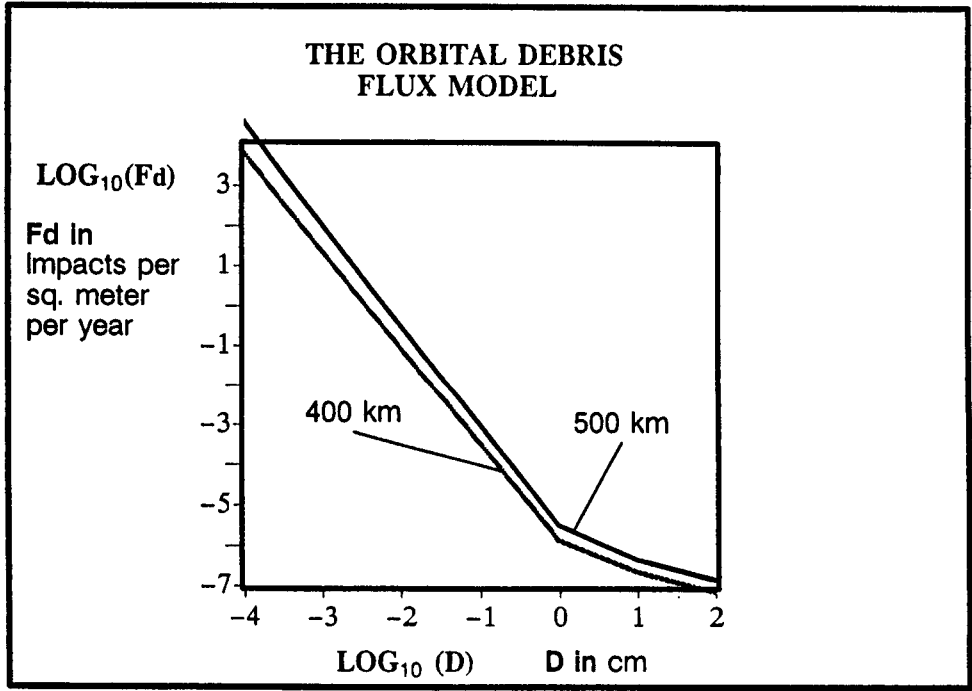
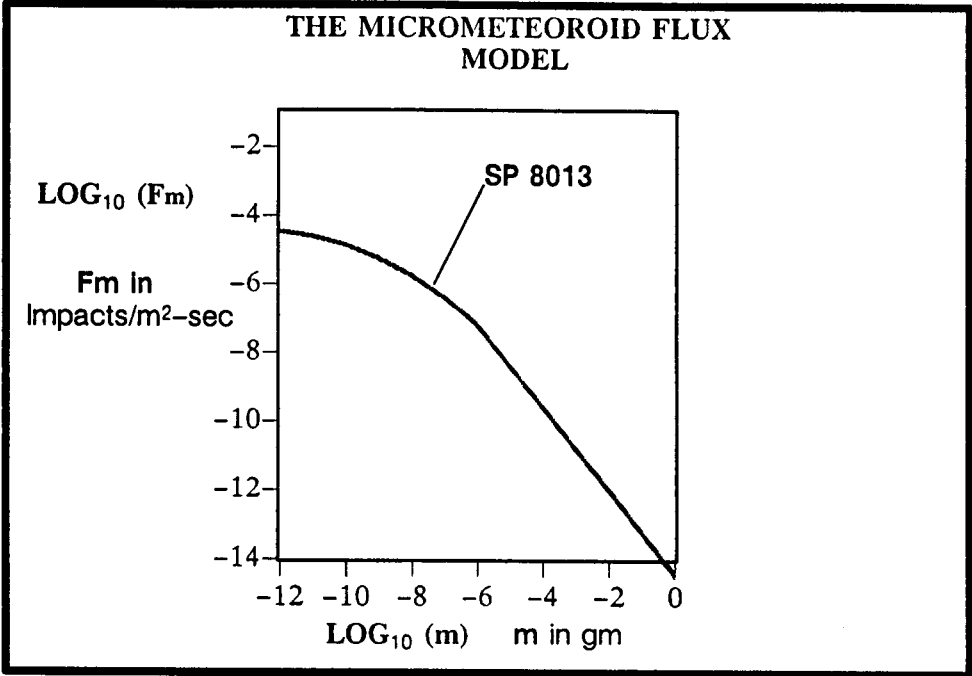

Figure 1. Illustration of the Micrometeoroid and Orbital Debris Models as Reported in SSP 30425

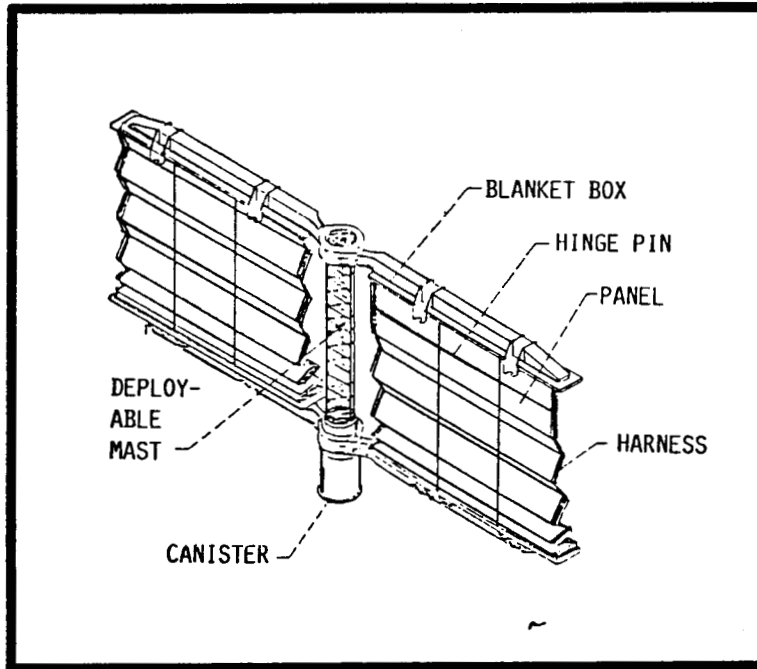

Figure 2. Deployable-Retractable Solar Array Structure for the Space Station Photovoltaic Power Module

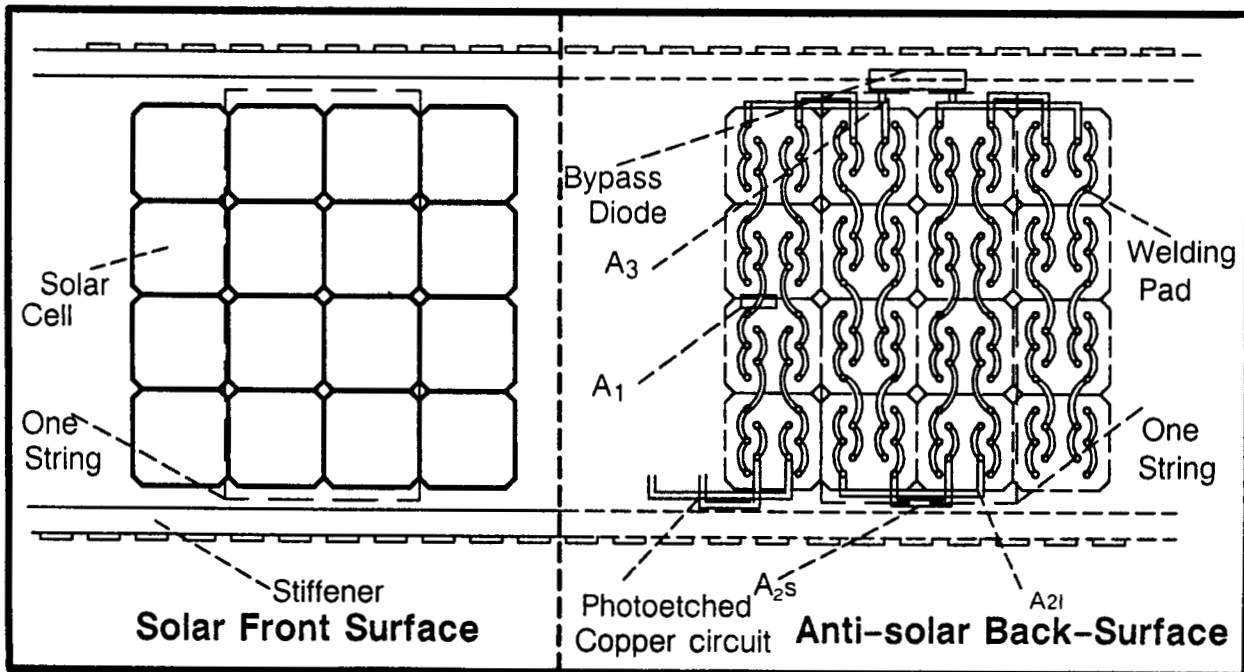

Figure 3. Solar Cell String Investigated for Open Circuit Probability Due to Particle Impacts

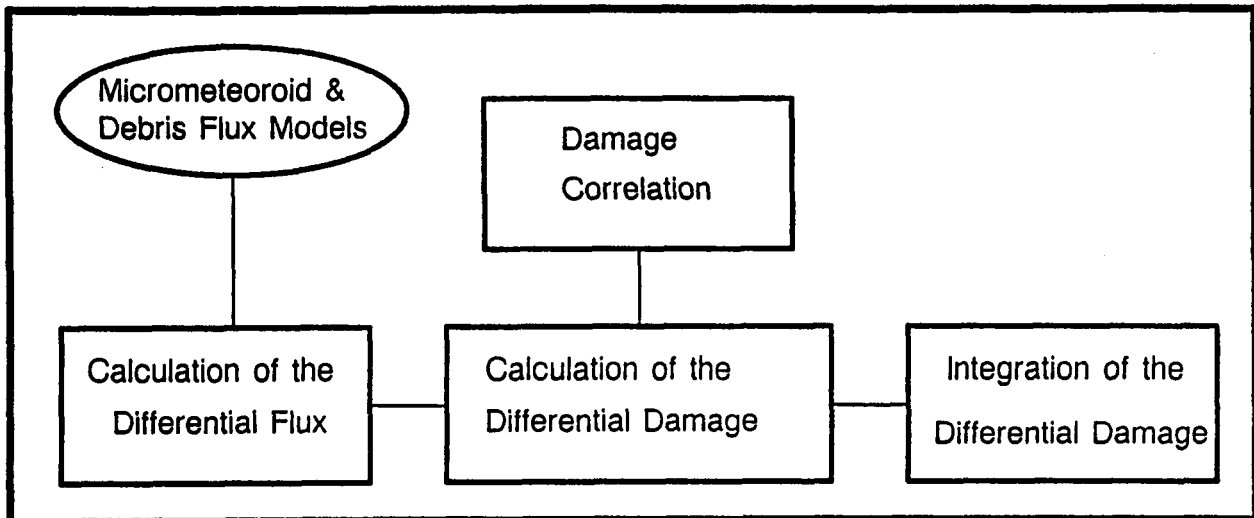

Figure 4. Flow of Calculation of the Damage Induced by the Micrometeoroid and Debris Impacts on the Solar Surface of the Array

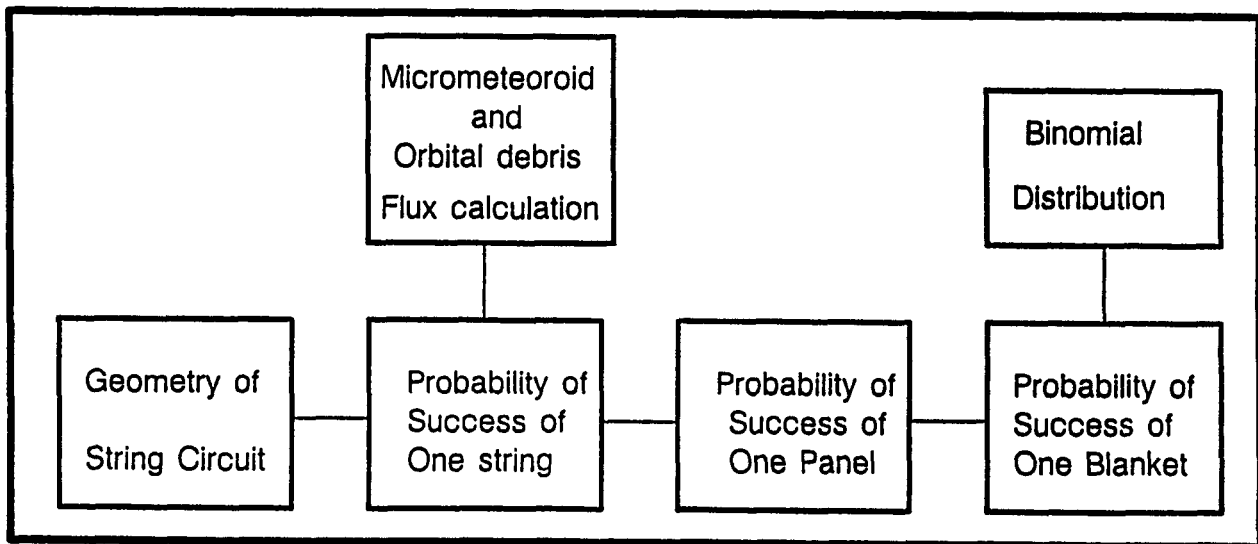

Figure 5. Flow of Calculation of the Probability of Success of the Solar Array Blanket

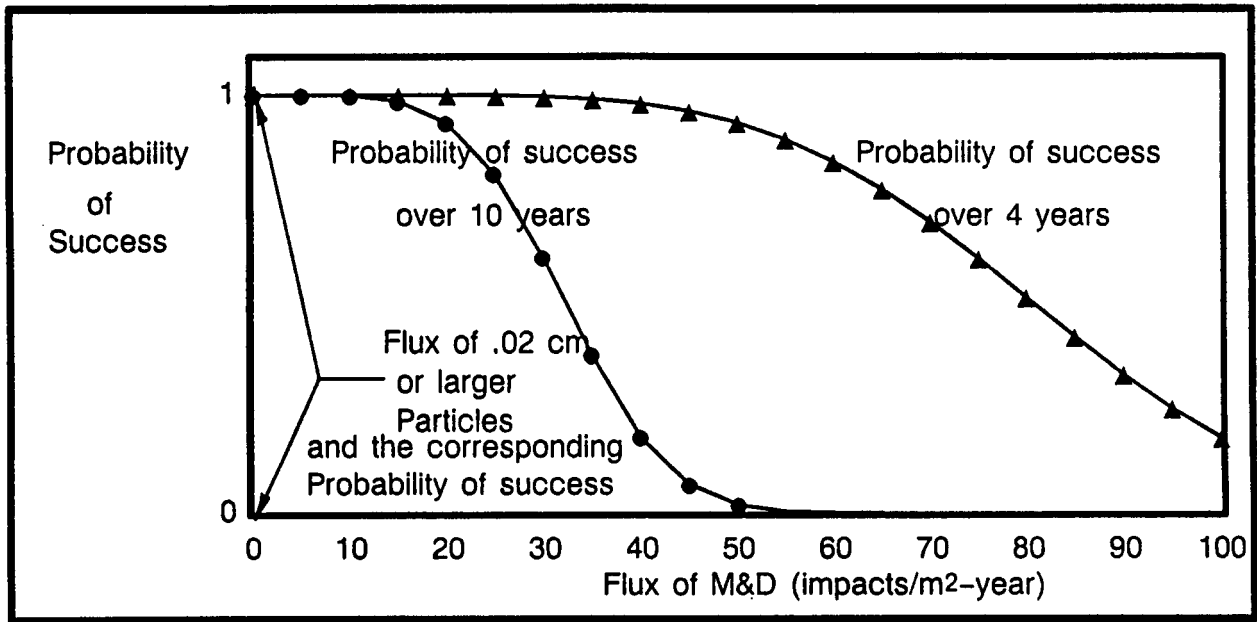

Figure 6. Probability of success of a Solar Array Blanket as a Function of the M&D Flux



Report Documentation Page

1. Report No. NASA TM-102287		2. Government Accession No.		3. Recipient's Catalog No.	
4. Title and Subtitle Effect of Micrometeoroid and Space Debris Impacts on the Space Station Freedom Solar Array Surfaces				5. Report Date	
				6. Performing Organization Code	
7. Author(s) Henry K. Nahra				8. Performing Organization Report No. E-4955	
				10. Work Unit No. 474-46-10	
9. Performing Organization Name and Address National Aeronautics and Space Administration Lewis Research Center Cleveland, Ohio 44135-3191				11. Contract or Grant No.	
				13. Type of Report and Period Covered Technical Memorandum	
12. Sponsoring Agency Name and Address National Aeronautics and Space Administration Washington, D.C. 20546-0001				14. Sponsoring Agency Code	
15. Supplementary Notes Prepared for the 1989 Spring Meeting of the Materials Research Society, San Diego, California, April 24-29, 1989.					
16. Abstract Both solar and antisolar surfaces of the Space Station Freedom solar arrays are vulnerable to micrometeoroid and space debris impacts. Impacts on the solar surface result in damage to the active area of the solar cell and a corresponding reduction in generated power. Impacts on the antisolar surface could result in damage to the circuit which interconnects the cells which in turn may produce open circuit strings or panels. This paper presents an evaluation of the power degradation resulting from the impacts of micrometeoroid and space debris on the solar surface of the array blanket. Moreover, given a particle diameter that could damage the circuit interconnecting the cells, this paper computes the probability of an open circuit panel, and ultimately the probability that the solar array blanket will meet the power requirement over the design lifetime.					
17. Key Words (Suggested by Author(s)) Micrometeoroid; Space debris; Solar surface Anti-solar surface; Solar array; Photo-etched circuit; Blanket; Hypervelocity impact; Damage; Flux; Probability of success			18. Distribution Statement Unclassified - Unlimited Subject Category 18		
19. Security Classif. (of this report) Unclassified		20. Security Classif. (of this page) Unclassified		21. No of pages 12	22. Price* A03