

INDEPENDENT ORBITER ASSESSMENT

ASSESSMENT OF THE EPD&C REMOTE MANIPULATOR SYSTEM

26 FEBRUARY 1988

MCDONNELL DOUGLAS ASTRONAUTICS COMPANY
HOUSTON DIVISION

SPACE TRANSPORTATION SYSTEM ENGINEERING AND OPERATIONS SUPPORT

WORKING PAPER NO. 1.0-WP-VA88003-35

INDEPENDENT ORBITER ASSESSMENT
ASSESSMENT OF THE EPD&C/REMOTE MANIPULATOR SYSTEM FMEA/CIL

04 MARCH 1988

This Working Paper is Submitted to NASA under
Task Order No. VA88003, Contract NAS 9-17650

PREPARED BY: *W.W. Robinson*
W.W. Robinson
Subsystem Analyst
Independent Orbiter
Assessment

APPROVED BY: *K.R. Schmeckpeper*
K.R. Schmeckpeper
Subsystem Manager
Independent Orbiter
Assessment

APPROVED BY: *A.J. Marino*
A.J. Marino
Section Manager-FMEA/CIL
Independent Orbiter
Assessment

APPROVED BY: *G.W. Knori*
G.W. Knori
Technical Manager
Independent Orbiter
Assessment

APPROVED BY: *Gordon T. Hornback*
G.L. Hornback
Project Manager
STSEOS

CONTENTS

	Page
1.0 EXECUTIVE SUMMARY	1
2.0 INTRODUCTION	4
2.1 Purpose	4
2.2 Scope	4
2.3 Analysis Approach	4
2.4 RMS Ground Rules and Assumptions	5
3.0 SYSTEM DESCRIPTION	6
3.1 Design and Function	6
3.2 Interfaces and Locations	7
3.3 Hierarchy	7
4.0 ASSESSMENT RESULTS	13
4.1 Assessment Results - EPD&C/RMS Remote Manipulator Arm Subsystem (05-6IA)	24
4.2 Assessment Results - EPD&C/RMS Manipulator Deploy Control Subsystem (05-6IB)	25
4.3 Assessment Results - EPD&C/RMS Manipulator Latch Control Subsystem (05-6IC)	25
4.4 Assessment Results - EPD&C/RMS Shoulder/Retention Arm and Jettison Subsystem (05-6ID)	26
5.0 REFERENCES	27
APPENDIX A ACRONYMS	A-1
APPENDIX B DEFINITIONS, GROUND RULES, AND ASSUMPTIONS	B-1
B.1 Definitions	B-2
B.2 Project Level Ground Rules and Assumptions	B-4
B.3 Subsystem Specific Ground Rules and Assumptions	B-6
APPENDIX C ASSESSMENT WORKSHEETS	C-1
APPENDIX D CRITICAL ITEMS	D-1
APPENDIX E ANALYSIS WORKSHEETS	E-1
APPENDIX F NASA FMEA TO IOA WORKSHEET CROSS REFERENCE/RECOMMENDATION	F-1

List of Figures

	Page
Figure 1 - EPD&C/RMS FMEA/CIL ASSESSMENT	3
Figure 2 - EPD&C/RMS SUBSYSTEM (05-6I) OVERVIEW	8
Figure 3 - EPD&C/RMS REMOTE MANIPULATOR ARM (05-6IA)	9
Figure 4 - EPD&C/RMS MANIPULATOR DEPLOY CONTROL (05-6IB)	10
Figure 5 - EPD&C/RMS MANIPULATOR LATCH CONTROL (05-6IC)	11
Figure 6 - EPD&C/RMS MANIPULATOR ARM SHOULDER JETTISON AND RETENTION ARM JETTISON (05-6ID)	12

List of Tables

	Page
Table I - SUMMARY OF IOA FMEA ASSESSMENT	13
Table II - SUMMARY OF IOA CIL ASSESSMENT	14
Table III - SUMMARY OF IOA RECOMMENDED FAILURE MODES CRITICALITIES	14
Table IV - SUMMARY OF IOA RECOMMENDED CRITICAL ITEMS	15
Table V - IOA WORKSHEET NUMBERS	16

Independent Orbiter Assessment
Assessment of the EPD&C/RMS FMEA CIL

1.0 EXECUTIVE SUMMARY

The McDonnell Douglas Astronautics Company (MDAC) was selected in June 1986 to perform an Independent Orbiter Assessment (IOA) of the Failure Modes and Effects Analysis (FMEA) and Critical Items List (CIL). Direction was given by the STS Orbiter and GFE Projects Office to perform the hardware analysis using the instructions and ground rules defined in NSTS 22206, Instructions for Preparation of FMEA and CIL, 10 October 1986.

The IOA effort first completed an analysis of the Electrical Power Distribution and Control (EPD&C)/Remote Manipulator System (RMS) hardware, generating draft failure modes and potential critical items. To preserve independence, this analysis was accomplished without reliance upon the results contained within the NASA FMEA/CIL documentation. The IOA analysis of the EPD&C/RMS hardware initially generated three hundred and forty-five (345) failure mode worksheets and identified one hundred and seventeen (117) Potential Critical Items (PCIs) before starting the assessment process. These analysis results were compared to the proposed NASA Post 51-L baseline of one hundred and thirty-two (132) FMEAs and sixty-six (66) CIL items, which were generated using the NSTS-22206 FMEA/CIL instructions. IOA generated failure mode analysis worksheets for both port and starboard Remote Manipulator Systems whereas the NASA generated FMEAs for only one system (did not specify which). The IOA analysis was performed on a component level for components assigned reference designator numbers on the drawings with one component per worksheet. The NASA analysis was performed with like multiple similar components on one FMEA. In some cases the NASA FMEAs were generated for an entire circuit without necessarily specifying the components included in the circuit by any identification number, thus direct comparisons of the IOA and NASA analyses were not meaningful in the sense of numbers of failures and identification of criticalities that have any uniformity. Efforts to compare the two analyses required consolidation of components in all but a few cases where the items were single point failure items as some of the switches were found to be. Twenty-eight (28) additional IOA failure mode analysis worksheets were generated to facilitate comparison. Upon completion of the assessment, five (5) issue items were identified that involved critical items where IOA recommends that NASA FMEAs generated for that failure mode of the component or where the NASA Criticality for that failure mode of that component be upgraded. There were also six (6) issues identified where IOA recommends upgrading of the NASA assigned criticality but these are not critical items list candidates.

Some of the miscompares arose due to differences between the NASA and IOA FMEA/CIL preparation instructions. NASA had used an older ground rules document which has since been superseded by the NSTS 22206 used by the IOA. After comparison, there were no other discrepancies found that were not already identified by NASA, and the remaining issues may be attributed to differences in ground rules.

It may be noted that numerical values appear to disagree between charts and tables. Figure 1 "Remote Manipulator Arm" block lists 5 issues for FMEAs and 5 issues for CIL items. The FMEA issues are also CIL issues. Figure 1 "Arm/Shoulder Jettison" block lists 6 FMEA issues which are not considered critical items.

EPD&C/RMS ASSESSMENT OVERVIEW

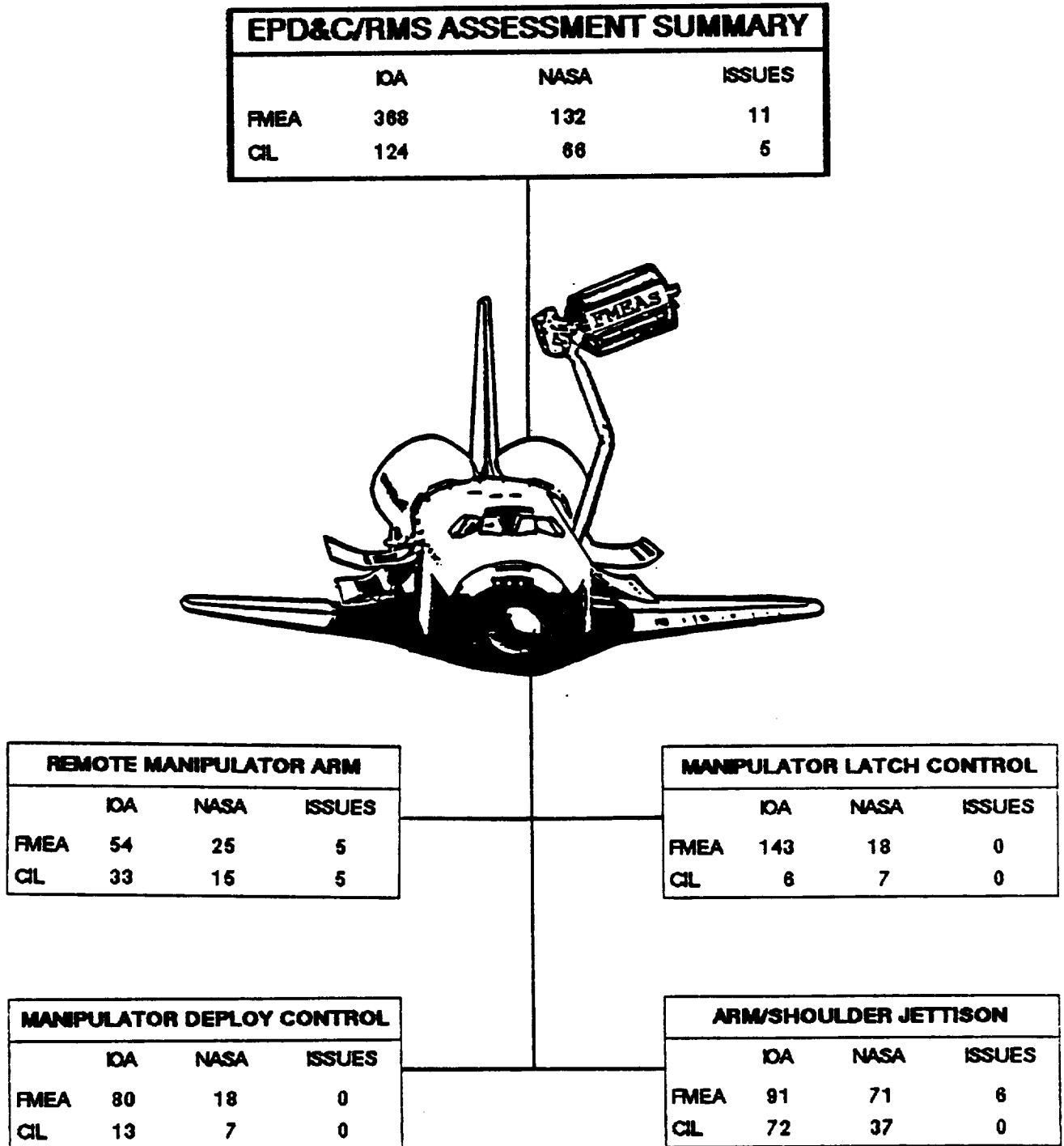

Figure 1 - EPD&C/RMS FMEA/CIL ASSESSMENT

2.0 INTRODUCTION

2.1 Purpose

The 51-L Challenger accident prompted the NASA to readdress safety policies, concepts, and rationale being used in the National Space Transportation System (NSTS). The NSTS Office has undertaken the task of reevaluating the FMEA/CIL for the Space Shuttle design. The MDAC is providing an independent assessment of the proposed Post 51-L Orbiter FMEA/CIL for completeness and technical accuracy.

2.2 Scope

The scope of the independent FMEA/CIL assessment activity encompasses those Shuttle Orbiter subsystems and GFE hardware identified in the Space Shuttle Independent FMEA/CIL Assessment Contractor Statement of Work. Each subsystem analysis addresses hardware, functions, internal and external interfaces, and operational requirements for all mission phases.

2.3 Analysis Approach

The independent analysis approach is a top-down analysis utilizing as-built drawings to breakdown the respective subsystem into components and low-level hardware items. Each hardware item is evaluated for failure mode, effects, and criticality. These data are documented in the respective subsystem analysis report, and are used to assess the proposed Post 51-L NASA and Prime Contractor FMEA/CIL. The IOA analysis approach is summarized in the following Steps 1.0 through 3.0. Step 4.0 summarizes the assessment of the NASA and Prime Contractor FMEA/CIL which is documented in this report.

Step 1.0 Subsystem Familiarization

- 1.1 Define subsystem functions
- 1.2 Define subsystem components
- 1.3 Define subsystem specific ground rules and assumptions

Step 2.0 Define subsystem analysis diagram

- 2.1 Define subsystem
- 2.2 Define major assemblies
- 2.3 Develop detailed subsystem representations

Step 3.0 Failure events definition

- 3.1 Construct matrix of failure modes
- 3.2 Document IOA analysis results

Step 4.0 Compare IOA analysis data to NASA FMEA/CIL

- 4.1 Resolve differences
- 4.2 Review in-house
- 4.3 Document assessment issues
- 4.4 Forward findings to Project Manager

2.4 Ground Rules and Assumptions

The ground rules and assumptions used in the IOA are defined in Appendix B. The EPD&C/RMS specific ground rules and assumptions are defined in paragraph B.3 of Appendix B.

3.0 SUBSYSTEM DESCRIPTION

3.1 Design and Function

The EPD&C/RMS subsystem provides the electrical power and power control circuitry required to safely deploy, operate, control, and stow one port and one starboard RMS. The EPD&C/RMS is a subset of the Orbiter EPD&C subsystem and uses the same three main busses and the same type of distribution and control hardware that is used to supply electrical power to the rest of the space shuttle subsystems. In addition, electrical power and control circuitry is provided to guillotine the appropriate cabling and jettison either or both the remote manipulator arms in the event it becomes necessary for crew/vehicle safety.

Although the EPD&C/RMS subsystem is designed to supply the required electrical power to both a port and a starboard RMS on a given mission, only one RMS can be powered-on at a given time. The port and starboard RMSs are essentially mirror images of one another. Some of the EPD&C/RMS electrical power control switches are common to both the port and starboard systems and some switches are dedicated to one or the other RMS. The port and starboard EPD&C/RMS subsystems are essentially identical in design. The port and starboard systems do differ in that power and control bus assignments are not the same for both systems.

The EPD&C/RMS subsystem consists of the following subdivisions:

1. The EPD&C/RMS Remote Manipulator Arm (05-6IA) subdivision consists of the hardware to provide Main Bus 28 volts Direct Current (DC) and 115 volts, three-phase (3-PH) and single-phase (1-PH), 400 Hertz (Hz) Alternating Current (AC) primary and backup (standby redundant) power to both the port and starboard (only one at a time) Remote Manipulator Arms for operation of its control electronics, heaters, lights and drive motors.
2. The EPD&C/RMS Manipulator Deploy Control (05-6I) subdivision consists of the hardware to provide Main Bus 28 volts DC and 115 volts, 3-phase (3-PH), 400 Hz AC power to the Motor Control Assemblies (MCAs) to control power to the two electrical motors that drive the actuator to physically drive the appropriate Manipulator Positioning Mechanism (MPM) to stow or deploy the port and starboard Remote Manipulator Arms.

3.1 Design and Function cont'd

3. The EPD&C/RMS Manipulator Latch Control (05-6IC) subdivision consists of the hardware to provide Main Bus 28 volts DC and 115 volts, 3-phase (3-PH), 400 Hz AC power to the MCAs to control power to the three sets of electrical motor pairs that drive the retention latch actuators to release or latch position. There are three retention latch mechanisms with one located at each of the forward, mid, and aft positions for the port arm and another set for the starboard arm.
4. The EPD&C/RMS Manipulator Arm Shoulder Jettison and Retention Arm Jettison (05-6ID) subdivision consists of the hardware to provide the 28 volts DC and control switching to safely arm and fire the Pyro Initiator Controllers (PICs) that enable detonation of the explosives to guillotine the necessary RMS cables and jettison either or both the port and/or starboard arms if it becomes necessary for crew/vehicle safety.

3.2 Interfaces and Locations

The remote manipulator arm is attached to the Orbiter longeron (port, starboard, or both) through a roll-out deployment mechanism. The RMS is operated by a crewmember using direct viewing and Closed Circuit Television (CCTV) from the Display and Control (D&C) station on the aft flight deck. Most of the EPD&C/RMS switches are located on panels A8A2 and A14. The Payload Bay Mechanical (PLBM) power switches that control the power to the Motor Control Assemblies are located on panel R13A1 in the cockpit and the circuit breakers are located on the standard circuit breaker panels.

3.3 Hierarchy

Figure 2 illustrates the Hierarchy of the EPD&C/RMS and the corresponding subdivisions. The subdivisions are represented in Figures 3 through 6.

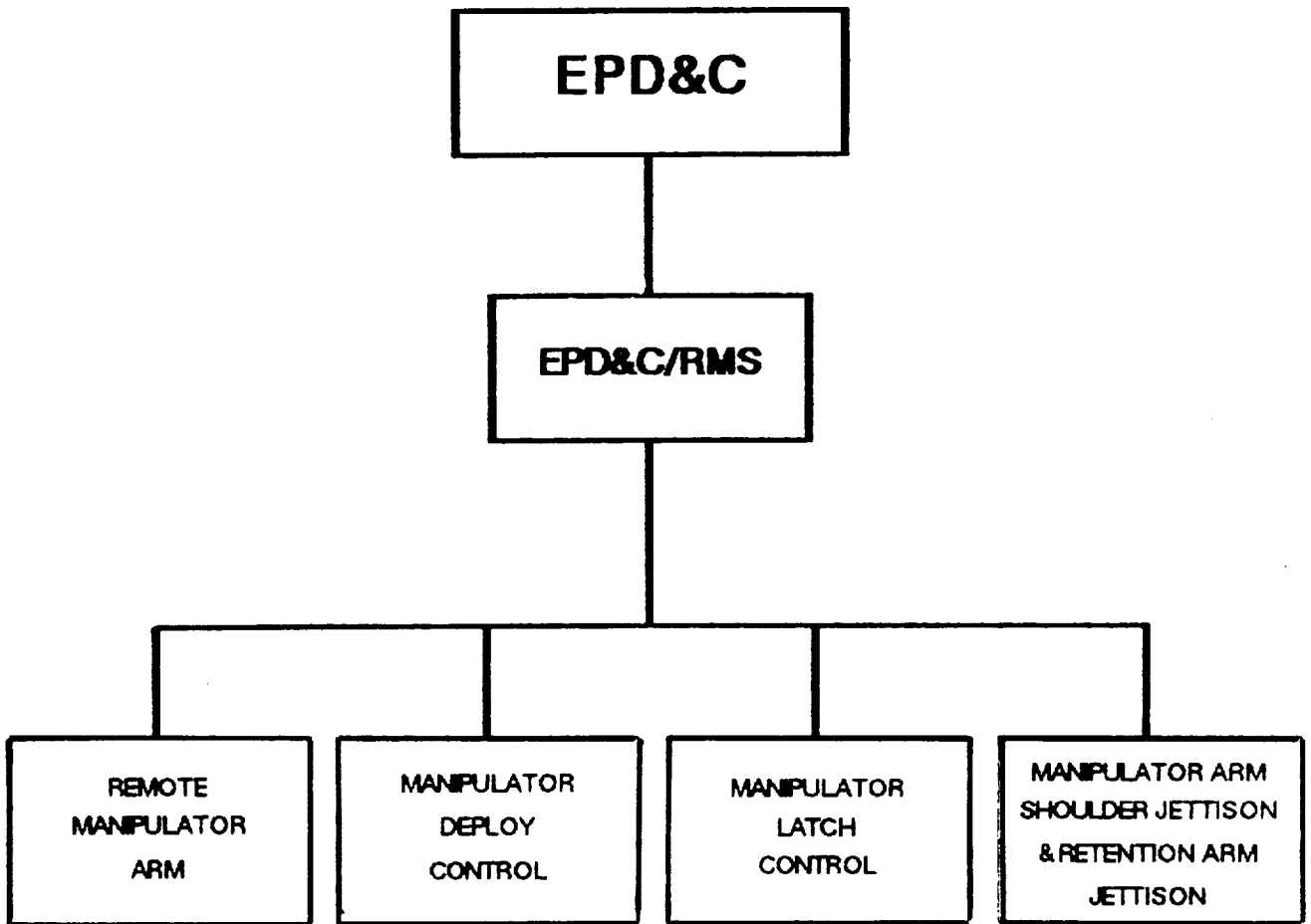

Figure 2 - EPD&C/RMS SUBSYSTEM (05-6I) OVERVIEW

REMOTE MANIPULATOR ARM

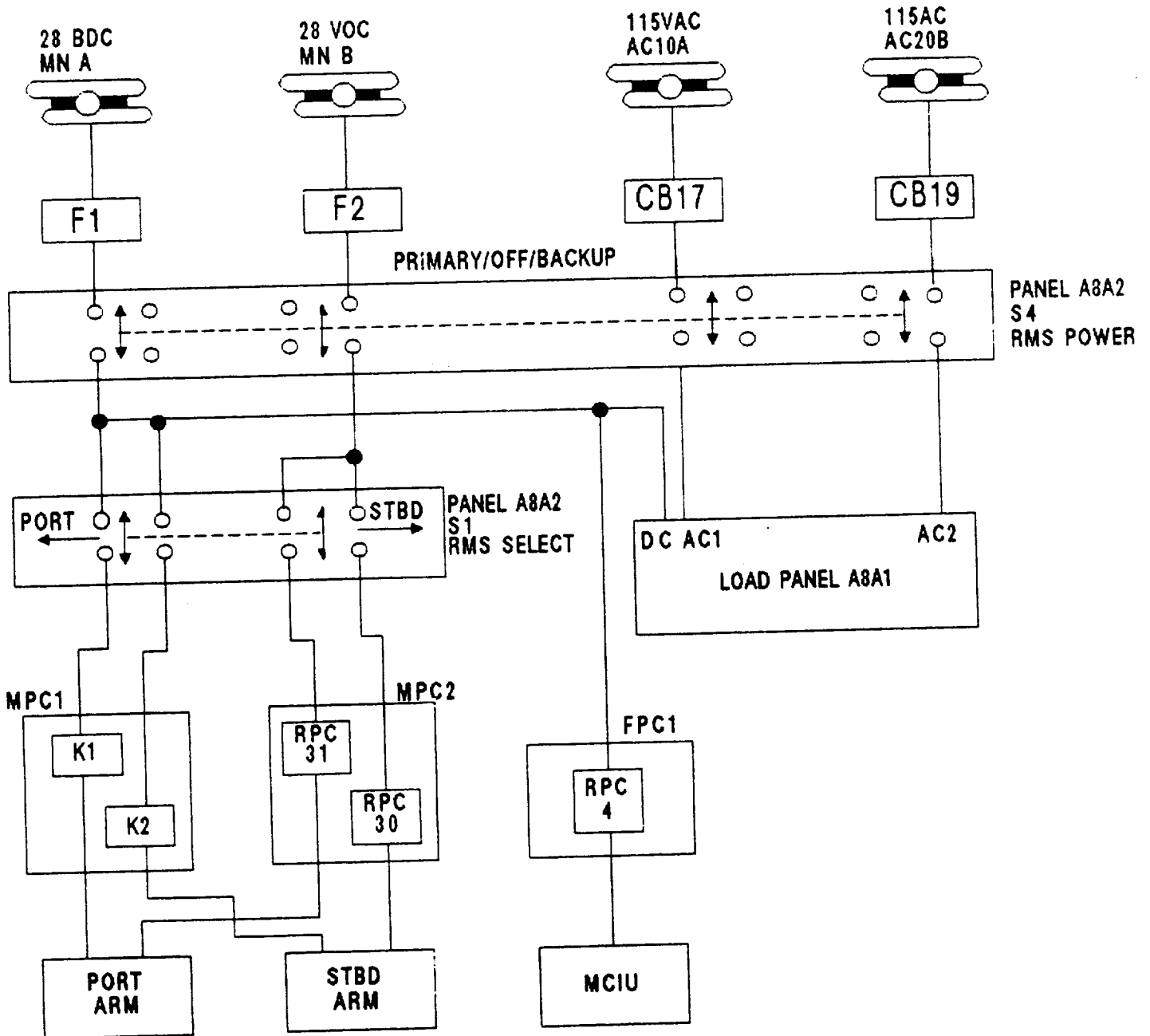
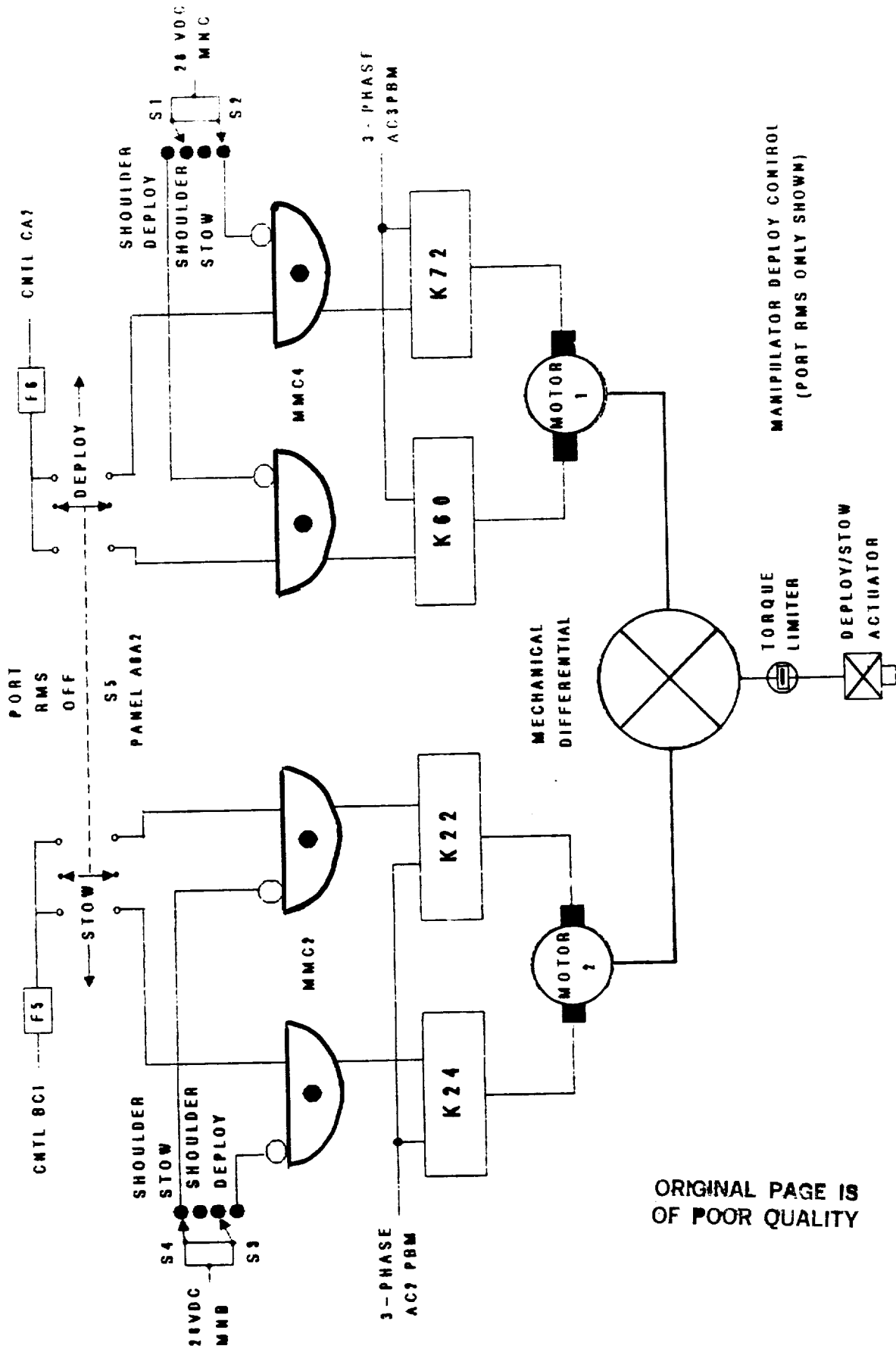

Figure 3 - EPD&C/RMS REMOTE MANIPULATOR ARM (05-6IA)



ORIGINAL PAGE IS
OF POOR QUALITY

Figure 4 - EPD&C/RMS MANIPULATOR DEPLOY CONTROL (05-61B)

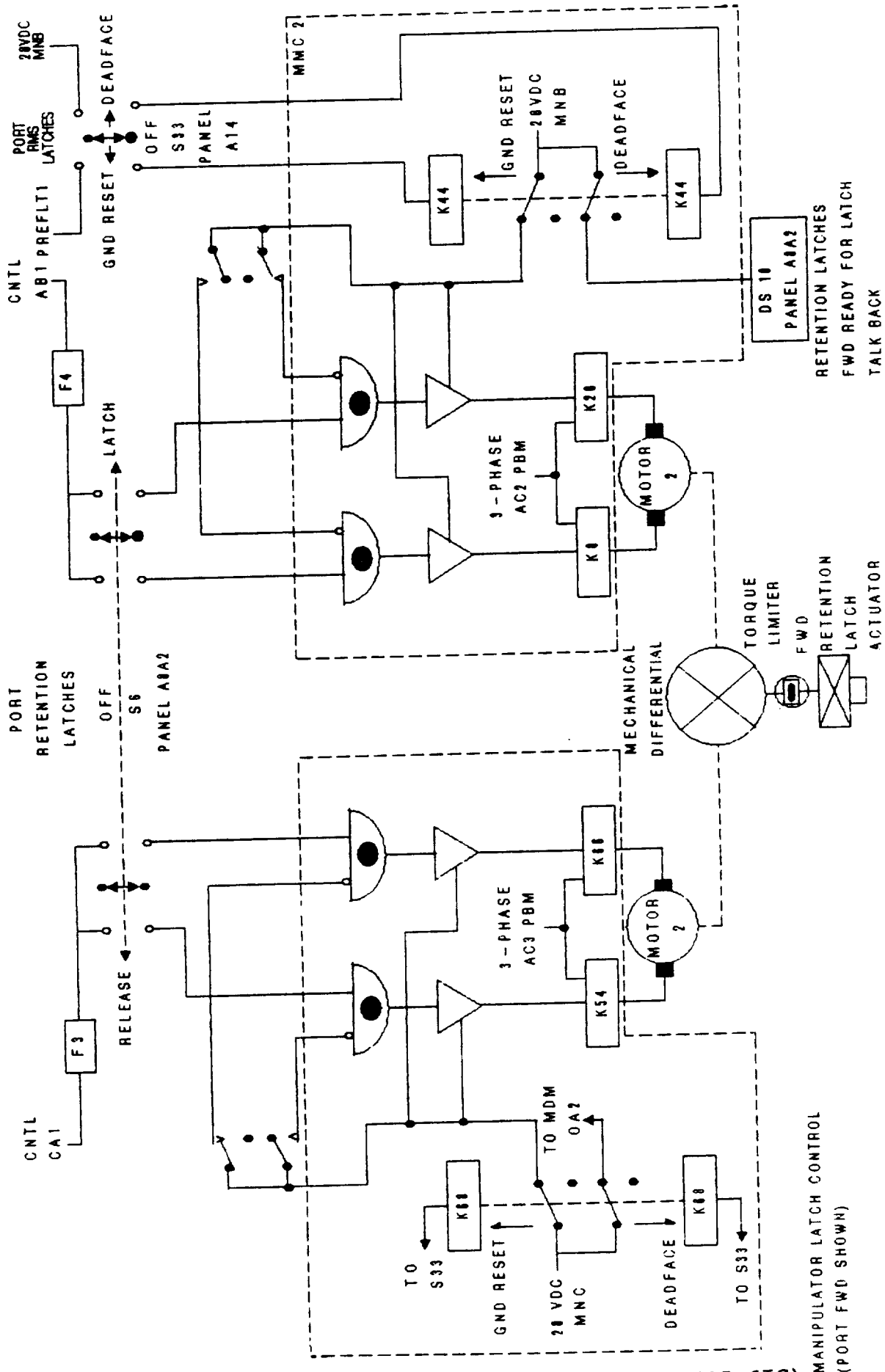

Figure 5 - EPD&C/RMS MANIPULATOR LATCH CONTROL (05-6IC)

RMS PYRO JETTISON SYSTEM

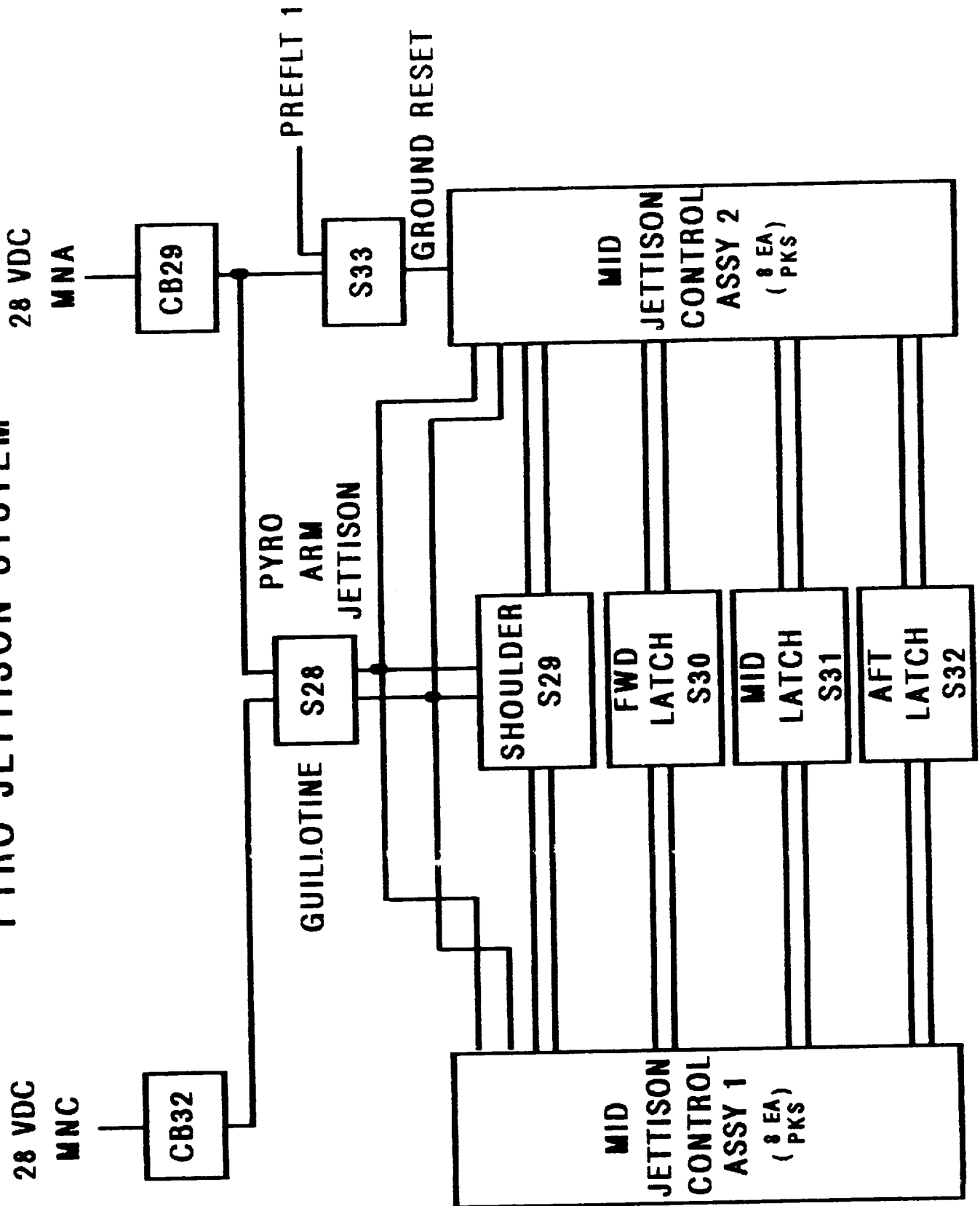

Figure 6 - EPD&C/RMS MANIPULATOR ARM SHOULDER JETTISON AND RETENTION ARM JETTISON (05-61D)

4.0 ASSESSMENT RESULTS

The IOA analysis of the EPD&C/RMS hardware initially generated three hundred and forty-five (345) failure mode worksheets and identified one hundred and seventeen (117) Potential Critical Items (PCIs) before starting the assessment process. These analysis results were compared to the proposed NASA Post 51-L baseline of one hundred and thirty-two (132) FMEAs and sixty-six (66) CIL items, which were generated using the NSTS-22206 FMEA/CIL instructions. IOA generated failure mode analysis worksheets for both port and starboard Remote Manipulator Systems whereas the NASA generated FMEAs for only one system (did not specify which). The IOA analysis was performed on a component level for components assigned reference designator numbers on the drawings with one component per worksheet. The NASA analysis was performed with like multiple similar components on one FMEA. In some cases the NASA FMEAs were generated for an entire circuit without necessarily specifying the components included in the circuit by any identification number, thus direct comparisons of the IOA and NASA analyses were not meaningful in the sense of numbers of failures and identification of criticalities that have any uniformity. Efforts to compare the two analyses required consolidation of components in all but a few cases where the items were single point failure items as some of the switches were found to be. Twenty-eight (28) additional IOA failure mode analysis worksheets were generated to facilitate comparison. Upon completion of the assessment, five (5) issue items were identified that involved critical items where IOA recommends that NASA FMEAs generated for that failure mode of the component or where the NASA Criticality for that failure mode of that component be upgraded. There were also six (6) issues identified where IOA recommends upgrading of the NASA assigned criticality but these are not critical items list candidates. A summary of the quantity of NASA FMEAs assessed, versus the recommended IOA baseline, and any issues identified is presented in Table I.

Table I Summary of IOA FMEA Assessment			
Subdivision	NASA	IOA	Issues
05-6IA	25	54	5
05-6IB	18	80	0
05-6IC	18	143	0
05-6ID	71	91	6
TOTAL	132	368	11

A summary of the quantity of NASA CIL items assessed, versus the recommended IOA baseline, and any issues identified is presented in Table II.

Table II Summary of IOA CIL Assessment			
Subdivision	NASA	IOA	Issues
05-6IA	15	33	5
05-6IB	7	13	0
05-6IC	7	6	0
05-6ID	37	72	0
TOTAL	66	124	5

Appendix C presents the detailed assessment worksheets for each failure mode identified and assessed. Appendix D highlights the NASA Critical Items and corresponding IOA worksheet ID. Appendix E contains IOA analysis worksheets supplementing previous analysis results reported in Space Transportation System Engineering and Operations Support (STSEOS) Working Paper No. 1.0-WP-VA86001-26, Analysis of the EPD&C/RMS Subsystem, 27 February, 1987. Appendix F provides a cross reference between the NASA FMEA and corresponding IOA worksheet(s). IOA recommendations are also summarized.

Table III presents a summary of the IOA recommended failure criticalities for the Post 51-L FMEA baseline. Further discussion of each of these subdivisions and the applicable failure modes is provided in subsequent paragraphs.

TABLE III Summary of IOA Recommended Failure Criticalities							
Criticality:	1/1	2/1R	2/2	3/1R	3/2R	3/3	TOTAL
05-6IA	4	16	13	1	8	12	54
05-6IB	10	1	2	4	31	32	80
05-6IC	0	6	0	4	58	75	143
05-6ID	10	62	0	0	13	6	91
TOTAL	24	85	15	9	110	125	368

Of the failure modes analyzed, one hundred and twenty-four (124) were determined to be critical items. A summary of the IOA recommended critical items is presented in Table IV.

TABLE IV Summary of IOA Recommended Critical Items							
Criticality:	1/1	2/1R	2/2	3/1R	3/2R	3/3	TOTAL
05-6IA	4	16	13	0	0	0	33
05-6IB	10	1	2	0	0	0	13
05-6IC	0	6	0	0	0	0	6
05-6ID	10	62	0	0	0	0	72
TOTAL	24	85	15	0	0	0	124

The scheme for assigning IOA assessment (Appendix C) and analysis (Appendix E) worksheet numbers is shown in Table V. For convenience Table V is subdivided into V-A thru V-D corresponding to the four major subdivisions of the EPD&C/RMS System.

TABLE V-A IOA WORKSHEET NUMBERS		(1)
Remote Manipulator Arm Components	(05-6IA)	ID Number
SWITCH, S4		RMS-4001
SWITCH, S4		RMS-4002
SWITCH, S4		RMS-4003
SWITCH, S4		RMS-4004
SWITCH, S4		RMS-4005
SWITCH, S4		RMS-4006
SWITCH, S1		RMS-4007
SWITCH, S1		RMS-4008
SWITCH, S1		RMS-4009
SWITCH, S8		RMS-4010
SWITCH, S10		RMS-4011
SWITCHES, S8, S10		RMS-4012
SWITCH, S7		RMS-4013
SWITCH, S9		RMS-4014
SWITCHES, S7, S9		RMS-4015
FUSE, F1		RMS-4016
FUSE, F1		RMS-4017
FUSE, F2		RMS-4018
FUSE, F2		RMS-4019
RESISTOR, A3R2		RMS-4020
RESISTOR, A3R3		RMS-4021
RESISTOR, A2R2		RMS-4022
RESISTOR, A2R3		RMS-4023
RESISTOR, A1R1		RMS-4024
RESISTOR, A1R2		RMS-4025
RESISTOR, A3R1		RMS-4026
RESISTOR, A2R1		RMS-4027
CIRCUIT BREAKER, CB17		RMS-4028
CIRCUIT BREAKER, CB17		RMS-4029
CIRCUIT BREAKER, CB17		RMS-4030
CIRCUIT BREAKER, CB19		RMS-4031
CIRCUIT BREAKER, CB19		RMS-4032
CIRCUIT BREAKER, CB19		RMS-4033
RELAY, K1		RMS-4034
RELAY, K1		RMS-4035
RELAY, K1		RMS-4036
RELAY, K2		RMS-4037
RELAY, K2		RMS-4038
RELAY, K2		RMS-4039
FUSE, F26		RMS-4040
FUSE, F27		RMS-4041
REMOTE POWER CONTROLLER, RPC 27		RMS-4042
REMOTE POWER CONTROLLER, RPC 26		RMS-4043

TABLE V-A IOA WORKSHEET NUMBERS (Concluded)		(2)
REMOTE POWER CONTROLLER, RPC 4		RMS-4044
REMOTE POWER CONTROLLER, RPC 31		RMS-4045
REMOTE POWER CONTROLLER, RPC 30		RMS-4046
Remote Manipulator Arm Components	(05-6IA)	ID NUMBER
REMOTE POWER CONTROLLER, RPC 28		RMS-4047
REMOTE POWER CONTROLLER, RPC 29		RMS-4048
SWITCH, S4		RMS-4049X
RESISTOR, A2R2, A2R3, A3R2, A3R3		RMS-4050X
CIRCUIT BREAKER, 1 PH 3A RMS, BACKUP POWER		RMS-4051X
REMOTE POWER CONTROLLER, RPC 4		RMS-4052X
REMOTE POWER CONTROLLER, RPC 26, 27, 28, 29		RMS-4053X
REMOTE POWER CONTROLLER, RPC 30, RPC 31		RMS-4054X

TABLE V-B IOA WORKSHEET NUMBERS		(1)
Manipulator Deploy Control Components	(05-6IB)	ID Number
SWITCH, S1		RMS-4101
SWITCH, S1		RMS-4102
SWITCH, S2		RMS-4103
SWITCH, S2		RMS-4104
SWITCH, S5		RMS-4105
SWITCH, S5		RMS-4106
SWITCH, S2		RMS-4107
SWITCH, S2		RMS-4108A
SWITCH, S2		RMS-4108
SWITCH, S2		RMS-4108B
SWITCH, S2		RMS-4108C
SWITCH, S2		RMS-4108D
FUSE, F6		RMS-4109
FUSE, F5		RMS-4110
FUSE, F11		RMS-4111
FUSE, F10		RMS-4112
HYBRID RELAY, K72		RMS-4113
HYBRID RELAY, K72		RMS-4114
HYBRID RELAY, K49		RMS-4115
HYBRID RELAY, K49		RMS-4116
HYBRID RELAY, K60		RMS-4117
HYBRID RELAY, K60		RMS-4118
HYBRID RELAY, K51		RMS-4119
HYBRID RELAY, K51		RMS-4120
HYBRID RELAY, K22		RMS-4121
HYBRID RELAY, K22		RMS-4122
HYBRID RELAY, K62		RMS-4123
HYBRID RELAY, K62		RMS-4124
HYBRID RELAY, K24		RMS-4125
HYBRID RELAY, K24		RMS-4126
HYBRID RELAY, K50		RMS-4127

TABLE V-B IOA WORKSHEET NUMBERS (Cont'd)		(2)
Manipulator Deploy Control Components	(05-6IB)	ID Number
HYBRID RELAY, K50		RMS-4128
HYBRID DRIVERS, AR9, 11		RMS-4129
HYBRID DRIVERS, AR9, 11		RMS-4130
HYBRID DRIVERS, AR13, 15		RMS-4131
HYBRID DRIVERS, AR13, 15		RMS-4132
HYBRID DRIVERS, AR8, 10		RMS-4133
HYBRID DRIVERS, AR8, 10		RMS-4134
HYBRID DRIVERS, AR12, 14		RMS-4135
HYBRID DRIVERS, AR12, 14		RMS-4136
HYBRID DRIVERS, AR14, 18		RMS-4137
HYBRID DRIVERS, AR14, 18		RMS-4138
HYBRID DRIVERS, AR6, 8		RMS-4139
HYBRID DRIVERS, AR6, 8		RMS-4140
HYBRID DRIVERS, AR12, 16		RMS-4141
HYBRID DRIVERS, AR12, 16		RMS-4142
HYBRID DRIVERS, AR2, 4		RMS-4143
HYBRID DRIVERS, AR2, 4		RMS-4144
CIRCUIT BREAKER, CB2		RMS-4145
CIRCUIT BREAKER, CB2		RMS-4146
CIRCUIT BREAKER, CB7		RMS-4147
CIRCUIT BREAKER, CB7		RMS-4148
CIRCUIT BREAKER, CB12		RMS-4149
CIRCUIT BREAKER, CB12		RMS-4150
CIRCUIT BREAKER, CB3		RMS-4151
CIRCUIT BREAKER, CB3		RMS-4152
CIRCUIT BREAKER, CB9		RMS-4153
CIRCUIT BREAKER, CB9		RMS-4154
CIRCUIT BREAKER, CB13		RMS-4155
CIRCUIT BREAKER, CB13		RMS-4156
SWITCH, S2		RMS-4157
SWITCH, S2		RMS-4158
SWITCH, S3		RMS-4159
SWITCH, S3		RMS-4160
SWITCH, S7		RMS-4161
SWITCH, S7		RMS-4162
SWITCH, S9		RMS-4163
SWITCH, S9		RMS-4164
SWITCH, S12		RMS-4165
SWITCH, S12		RMS-4166
SWITCH, S13		RMS-4167
SWITCH, S13		RMS-4168
RESISTOR, R2		RMS-4169
RESISTOR, R3		RMS-4170
RESISTOR, R7		RMS-4171
RESISTOR, R9		RMS-4172
RESISTOR, R12		RMS-4173
RESISTOR, R13		RMS-4174

TABLE V-B IOA WORKSHEET NUMBERS (Concluded)		(3)
Manipulator Deploy Control Components	(05-6IB)	ID Number
SWITCH, S2		RMS-4175X
SWITCH, S2		RMS-4176X
SWITCH, S2		RMS-4177X
SWITCH, S2		RMS-4178X
SWITCH, S2		RMS-4179X
SWITCH, S2		RMS-4180X
SWITCH, S2		RMS-4181X
SWITCH, S2		RMS-4182X

TABLE V-C IOA WORKSHEET NUMBERS		(1)
Manipulator Latch Control Components	(05-6IC)	ID Number
HYBRID RELAY, K20		RMS-4201
HYBRID RELAY, K20		RMS-4202
HYBRID RELAY, K52		RMS-4203
HYBRID RELAY, K52		RMS-4204
HYBRID RELAY, K8		RMS-4205
HYBRID RELAY, K8		RMS-4206
HYBRID RELAY, K64		RMS-4207
HYBRID RELAY, K64		RMS-4208
FUSE, F4		RMS-4211
FUSE, F6		RMS-4212
RESISTOR, R27		RMS-4213
RESISTOR, R67		RMS-4214
RESISTOR, R28		RMS-4215
RESISTOR, R63		RMS-4216
RESISTOR, R2		RMS-4217
RESISTOR, R14		RMS-4218
RESISTOR, R25		RMS-4219
RESISTOR, R32		RMS-4220
RESISTOR, R26		RMS-4221
RESISTOR, R33		RMS-4222
HYBRID DRIVER, AR4		RMS-4223
HYBRID DRIVER, AR4		RMS-4224
HYBRID DRIVER, AR10		RMS-4225
HYBRID DRIVER, AR10		RMS-4226
HYBRID DRIVER, AR5		RMS-4227
HYBRID DRIVER, AR5		RMS-4228
HYBRID DRIVER, AR13		RMS-4229
HYBRID DRIVER, AR13		RMS-4230
FUSE, AR4F1		RMS-4231
FUSE, AR10F1		RMS-4232
FUSE, AR5F1		RMS-4233
FUSE, AR13F1		RMS-4234
HYBRID RELAY, K55		RMS-4235
HYBRID RELAY, K55		RMS-4236
HYBRID RELAY, K69		RMS-4237

TABLE V-C IOA WORKSHEET NUMBERS (Cont'd)		(2)
Manipulator Latch Control Components	(05-6IC)	ID Number
HYBRID RELAY, K69		RMS-4238
HYBRID RELAY, K43		RMS-4239
HYBRID RELAY, K43		RMS-4240
HYBRID RELAY, K57		RMS-4241
HYBRID RELAY, K57		RMS-4242
FUSE, F2		RMS-4245
FUSE, F4		RMS-4246
RESISTOR, R29		RMS-4247
RESISTOR, R65		RMS-4248
RESISTOR, R28		RMS-4249
RESISTOR, R61		RMS-4250
RESISTOR, R1		RMS-4251
RESISTOR, R11		RMS-4252
RESISTOR, R25		RMS-4253
RESISTOR, R14		RMS-4254
RESISTOR, R26		RMS-4255
RESISTOR, R15		RMS-4256
HYBRID RELAY, K75		RMS-4257
HYBRID RELAY, K75		RMS-4258
HYBRID RELAY, K78		RMS-4259
HYBRID RELAY, K78		RMS-4260
HYBRID RELAY, K73		RMS-4261
HYBRID RELAY, K73		RMS-4262
HYBRID RELAY, K76		RMS-4263
HYBRID RELAY, K76		RMS-4264
FUSE, F8		RMS-4267
FUSE, F2		RMS-4268
RESISTOR, R61		RMS-4269
RESISTOR, R41		RMS-4270
RESISTOR, R62		RMS-4271
RESISTOR, R40		RMS-4272
RESISTOR, R14		RMS-4273
RESISTOR, R2		RMS-4274
RESISTOR, R59		RMS-4275
RESISTOR, R31		RMS-4276
RESISTOR, R60		RMS-4277
RESISTOR, R33		RMS-4278
HYBRID RELAY, K54		RMS-4279
HYBRID RELAY, K54		RMS-4280
HYBRID RELAY, K56		RMS-4281
HYBRID RELAY, K56		RMS-4282
HYBRID RELAY, K66		RMS-4283
HYBRID RELAY, K66		RMS-4284
HYBRID RELAY, K44		RMS-4285
HYBRID RELAY, K44		RMS-4286
FUSE, F7		RMS-4289
FUSE, F3		RMS-4290
RESISTOR, R68		RMS-4291
RESISTOR, R34		RMS-4292

TABLE V-C IOA WORKSHEET NUMBERS (Cont'd)		(3)
Manipulator Latch Control Components	(05-6IC)	ID Number
RESISTOR, R64		RMS-4293
RESISTOR, R33		RMS-4294
RESISTOR, R12		RMS-4295
RESISTOR, R2		RMS-4296
RESISTOR, R35		RMS-4297
RESISTOR, R31		RMS-4298
RESISTOR, R34		RMS-4299
RESISTOR, R30		RMS-4300
HYBRID RELAY, K59		RMS-4301
HYBRID RELAY, K59		RMS-4302
HYBRID RELAY, K76		RMS-4303
HYBRID RELAY, K76		RMS-4304
HYBRID RELAY, K71		RMS-4305
HYBRID RELAY, K71		RMS-4306
HYBRID RELAY, K74		RMS-4307
HYBRID RELAY, K74		RMS-4308
FUSE, F5,		RMS-4311
FUSE, F9		RMS-4312
RESISTOR, R66		RMS-4313
RESISTOR, R66		RMS-4314
RESISTOR, R62		RMS-4315
RESISTOR, R67		RMS-4316
RESISTOR, R10		RMS-4317
RESISTOR, R2		RMS-4318
RESISTOR, R16		RMS-4319
RESISTOR, R64		RMS-4320
RESISTOR, R17		RMS-4321
RESISTOR, R65		RMS-4322
HYBRID RELAY, K24		RMS-4323
HYBRID RELAY, K24		RMS-4324
HYBRID RELAY, K27		RMS-4325
HYBRID RELAY, K27		RMS-4326
HYBRID RELAY, K12		RMS-4327
HYBRID RELAY, K12		RMS-4328
HYBRID RELAY, K29		RMS-4329
HYBRID RELAY, K29		RMS-4330
FUSE, 2 AMP, F3		RMS-4333
FUSE, 2 AMP, F3		RMS-4334
RESISTOR, R49		RMS-4335
RESISTOR, R22		RMS-4336
RESISTOR, R42		RMS-4337
RESISTOR, R23		RMS-4338
RESISTOR, R2		RMS-4339
RESISTOR, R3		RMS-4340
RESISTOR, R34		RMS-4341
RESISTOR, R33		RMS-4342
RESISTOR, R36		RMS-4343
RESISTOR, R31		RMS-4344

TABLE V-C IOA WORKSHEET NUMBERS (Concluded)		(4)
Manipulator Latch Control Components	(05-6IC)	ID Number
FUSE, F3, F4		RMS-4345X
SWITCH, S6		RMS-4346X
SWITCH, S6		RMS-4347X
SWITCH, S6		RMS-4348X
SWITCH, S6		RMS-4349X
SWITCH, S6		RMS-4350X
SWITCH, S6		RMS-4351X
SWITCH, S6		RMS-4352X
LIMIT SWITCH, LATCHED & RELEASED		RMS-4353X
LIMIT SWITCH, RELEASE		RMS-4354X
LIMIT SWITCH, LATCH		RMS-4355X

TABLE V-D IOA WORKSHEET NUMBERS		(1)
Manip Arm Arm/Shldr Retn/Jett Components	(05-6ID)	ID Number
RELAY, K44		RMS-4209
RELAY, K76		RMS-4210
RELAY, K57		RMS-4243
RELAY, K80		RMS-4244
RELAY, K77		RMS-4265
RELAY, K11		RMS-4266
RELAY, K68		RMS-4287
RELAY, K58		RMS-4288
RELAY, K78		RMS-4309
RELAY, K78		RMS-4310
RELAY, K23		RMS-4331
RELAY, K17		RMS-4332
SWITCH, S21		RMS-4501
SWITCH, S21		RMS-4502
SWITCH, S28		RMS-4503
SWITCH, S28		RMS-4504
SWITCH, S25		RMS-4505
SWITCH, S25		RMS-4506
SWITCH, S32		RMS-4507
SWITCH, S32		RMS-4508
SWITCH, S24		RMS-4509
SWITCH, S24		RMS-4510
SWITCH, S31		RMS-4511
SWITCH, S31		RMS-4512
SWITCH, S23		RMS-4513
SWITCH, S23		RMS-4514
SWITCH, S30		RMS-4515
SWITCH, S30		RMS-4516

TABLE V-D IOA WORKSHEET NUMBERS (Cont'd)

(2)

Manip Arm Arm/Shldr Retn/Jett Components (05-6ID)	ID Number
SWITCH, S22	RMS-4517
SWITCH, S22	RMS-4518
SWITCH, S29	RMS-4519
SWITCH, S29	RMS-4520
SWITCH, S33	RMS-4521
SWITCH, S33	RMS-4522
FUSE, F27	RMS-4523
CIRCUIT BREAKER, CB27	RMS-4524
CIRCUIT BREAKER, CB27	RMS-4525
CIRCUIT BREAKER, CB29	RMS-4526
CIRCUIT BREAKER, CB29	RMS-4527
CIRCUIT BREAKER, CB33	RMS-4528
CIRCUIT BREAKER, CB33	RMS-4529
CIRCUIT BREAKER, CB32	RMS-4530
CIRCUIT BREAKER, CB32	RMS-4531
PIC 1	RMS-4532
PIC 1	RMS-4533
PIC 12	RMS-4534
PIC 12	RMS-4535
PIC 1, 12	RMS-4536
PIC 1, 12	RMS-4537
PIC 6	RMS-4538
PIC 6	RMS-4539
PIC 17	RMS-4540
PIC 17	RMS-4541
PIC 6, 17	RMS-4542
PIC 6, 17	RMS-4543
PIC 8	RMS-4544
PIC 8	RMS-4545
PIC 19	RMS-4546
PIC 19	RMS-4547
PIC 8, 19	RMS-4548
PIC 8, 19	RMS-4549
PIC 10	RMS-4550
PIC 10	RMS-4551
PIC 21	RMS-4552
PIC 21	RMS-4553
PIC 10, 21	RMS-4554
PIC 10, 21	RMS-4555
PIC 2	RMS-4556
PIC 2	RMS-4557
PIC 13	RMS-4558
PIC 13	RMS-4559
PIC 2, 13	RMS-4560
PIC 2, 13	RMS-4561
PIC 7	RMS-4562
PIC 7	RMS-4563
PIC 18	RMS-4564

TABLE V-D IOA WORKSHEET NUMBERS (Concluded)		(3)
Manip Arm Arm/Shldr Retn/Jett Components (05-6ID)	ID Number	
PIC 18	RMS-4565	
PIC 7, 18	RMS-4566	
PIC 7, 18	RMS-4567	
PIC 9	RMS-4568	
PIC 9	RMS-4569	
PIC 20	RMS-4570	
PIC 20	RMS-4571	
PIC 9, 20	RMS-4572	
PIC 9, 20	RMS-4573	
PIC 11	RMS-4574	
PIC 11	RMS-4575	
PIC 22	RMS-4576	
PIC 22	RMS-4577	
PIC 11, 22	RMS-4578	
PIC 11, 22	RMS-4579	

4.1 Assessment Results - EPD&C/RMS Remote Manipulator Arm Subsystem (05-6IA)

The IOA analysis of the EPD&C/RMS Remote Manipulator Arm Subsystem generated forty-eight (48) failure mode worksheets and identified thirty-one (31) Potential Critical Items before starting the assessment process. Of the forty-eight (48) IOA FMEAs, three (3) were Criticality 1/1, fifteen (15) were Criticality 2/1R and thirteen (13) were Criticality 2/2. The NASA analysis consisted of twenty-five (25) FMEAs and fifteen (15) CIL items. Of the fifteen (15) CIL items, six (6) Criticality 1/1 and nine (9) were Criticality 2/1R. Each component, the function it performs and the failure modes identified were re-evaluated and the assessment was performed by comparison of the IOA FMEA/CILs to the NASA Post 51L FMEA/CILs. The IOA assessment recommends fifty-four (54) IOA FMEAs be established with four (4) having Criticality 1/1, sixteen (16) having Criticality 2/1R, thirteen having Criticality 2/2, one (1) having Criticality 3/1R, eight (8) having Criticality 3/2R, and three (3) having Criticality 3/3. The assessment identified thirty-three (33) Potential Critical Items with four (4) having Criticality 1/1, sixteen having Criticality 2/1R, and thirteen (13) having Criticality 2/2. The assessment identified five (5) issue items. IOA recommends that two (2) NASA FMEAs be generated with Criticality 2/1R, one (1) NASA FMEA be generated with Criticality 2/2, and one (1) NASA FMEA Criticality be upgraded to 2/1R from 3/1R and one upgraded from Criticality 2/2 to 2/1R.

4.2 Assessment Results - EPD&C/RMS Manipulator Deploy Control Subsystem (05-6IB)

The IOA analysis of the EPD&C/RMS Manipulator Deploy Control Subsystem generated seventy-four (74) failure mode worksheets and identified fourteen (14) Potential Critical Items before starting the assessment process. Of the seventy-four (74) IOA FMEAs, ten (10) were Criticality 1/1, two (2) were Criticality 2/1R, two (2) were Criticality 2/2, thirty (30) were Criticality 3/2R, and thirty (30) were Criticality 3/3. The NASA analysis consisted of eighteen (18) FMEAs and seven (7) CIL items. Of the seven (7) CIL items, five (5) were Criticality 1/1, and two (2) were Criticality 2/1R. Each component, the function it performs and the failure modes identified were re-evaluated and the assessment was performed by comparison of the IOA FMEA/CILs to the NASA Post 51L FMEA/CILs. The IOA assessment results is eighty (80) IOA FMEAs with ten (10) having Criticality 1/1, one (1) having Criticality 2/1R, two (2) having Criticality 2/2, four (4) having Criticality 3/1R, thirty-one (31) having Criticality 3/2R, and thirty-two (32) having Criticality 3/3. The assessment identified thirteen (13) Potential Critical Items with ten (10) having Criticality 1/1, one (1) having Criticality 2/1R, and two (2) having Criticality 2/2. The assessment identified no (0) issue items.

4.3 Assessment Results - EPD&C/RMS Manipulator Latch Control Subsystem (05-6IC)

The IOA analysis of the EPD&C/RMS Manipulator Latch Control Subsystem generated one hundred and forty-four (144) failure mode worksheets and identified no (0) Potential Critical Items before starting the assessment process. Of the one hundred and fifty-four (144) IOA FMEAs, seventy (70) were Criticality 3/2R and seventy-four (74) were Criticality 3/3. The NASA analysis consisted of eighteen (18) FMEAs and seven (7) CIL items. All of the seven (7) CIL items, five (5) were Criticality 2/1R. Each component, the function it performs and the failure modes identified were re-evaluated and the assessment was performed by comparison of the IOA FMEA/CILs to the NASA Post 51L FMEA/CILs. The IOA assessment results is one hundred and forty-three (143) IOA FMEAs with none (0) having Criticality 1/1, six (6) having Criticality 2/1R, none (0) having Criticality 2/2, four (4) having Criticality 3/1R, fifty-eight (58) having Criticality 3/2R, and seventy-five (75) having Criticality 3/3. The assessment identified six (6) Potential Critical Items having Criticality 2/1R. The assessment identified no (0) issue items.

4.4 Assessment Results - EPD&C/RMS Shoulder/Retention Arm and Jettison Subsystem (05-6ID)

The IOA analysis of the EPD&C/RMS Shoulder/Retention Arm and Jettison Subsystem generated seventy-nine (79) failure mode worksheets and identified seventy-two (72) Potential Critical Items before starting the assessment process. Of the seventy-nine (79) IOA FMEAs, ten (10) were Criticality 1/1, sixty-two were Criticality 2/1R, one (1) was Criticality 3/2R, and six (6) were Criticality 3/3. The NASA analysis consisted of seventy-one (71) FMEAs, thirty-seven (37 of which were CIL items. Of the thirty-seven (37) CIL items, twelve (12) were Criticality 1/1 and twenty-five (25) were Criticality 2/1R. Each component, the function it performs and the failure modes identified were re-evaluated and the assessment was performed by comparison of the IOA FMEA/CILs to the NASA Post 51L FMEA/CILs. The IOA assessment results is ninety-one (91) IOA FMEAs with ten (10) having Criticality 1/1, sixty-two (62) having Criticality 2/1R, none () having Criticality 2/2, none () having Criticality 3/1R, thirteen (13) having Criticality 3/2R, and six (6) having Criticality 3/3. The assessment identified ten (10) Potential Critical Items having Criticality 1/1 and sixty-two having Criticality 2/1R. The assessment identified no (0) issue items.

5.0 REFERENCES

Reference documentation available from NASA and Rockwell International Space Division was used in the analysis. The documentation used in the analysis includes the following:

1. NSTS 22206, Instructions for Preparation of Failure Modes and Effects Analysis (FMEA) and Critical Items List (CIL), Oct. 10, 1986
2. JSC-11174, Space Shuttle Systems Handbook, Rev. C, DCN-5, Sep. 13, 1985
3. VS72-956099, Rockwell International Electrical Schematics, Remote Manipulator System
4. Rockwell, International Space Division Reliability Desk Instruction No. 100-2G, Flight Hardware Failure Mode Effects Analysis (FMEA) & Critical Items List (CIL), January 31, 1984.

APPENDIX A

ACRONYMS and ABBREVIATIONS

AC	- Alternating Current
AOA	- Abort Once Around
AMP	- Ampere
ATO	- Abort To Orbit
CB	- Circuit Breaker
CIL	- Critical Items List
CKT	- Circuit
CUR	- Current
DC	- Direct Current
EPD&C	- Electrical Power Distribution and Control
FMC	- Forward Motor Controller
FMEA	- Failure Mode Effects Analysis
FPC	- Forward Power Controller
FUNC	- Functional
FWD	- Forward
GUILL	- Guillotine
HDW	- Hardware
HERM	- Hermetically
HW/F	- Hardware/Functional
HZ	- Hertz (cycles per second)
IOA	- Independent Orbiter Analysis
JETT	- Jettison
LIM	- Limiting
MCIU	- Manipulator Controller Interface Unit
MDAC	- McDonnell Douglas Astronautics Company
MDM	- Multiplexer/Demultiplexer
MFR	- Manned Foot Restraint
MMC	- Mid Motor Controller
MN	- Main 28 VDC Power Bus
MPC	- Mid Power Controller
NASA	- National Aeronautics and Space Administration
NSTS	- National Space Transportation System
N/A	- Not Applicable
OA	- Operational Aft
OF	- Operational Forward

ACRONYMS and ABBREVIATIONS (Cont'd)

P	- Pass
PBM	- Payload Bay Mechanical
PCA	- Power Controller Assembly
PCI	- Potential Critical Item
PH	- Phase
PIC	- Pyro Initiator Controller
POS	- Position
PYRO	- Pyrotechnic
RMS	- Remote Manipulator System
RPC	- Remote Power Controller
RTLS	- Return To Launch Site
STBD	- Starboard
TAL	- TransAtlantic Abort Landing
VAC	- Volts Alternating Current
VDC	- Volts Direct Current
1-PH	- Single Phase
3-PH	- Three Phase

APPENDIX B

DEFINITIONS, GROUND RULES, AND ASSUMPTIONS

- B.1 Definitions
- B.2 Project Level Ground Rules and Assumptions
- B.3 Subsystem-Specific Ground Rules and Assumptions

**APPENDIX B
DEFINITIONS, GROUND RULES, AND ASSUMPTIONS**

B.1 Definitions

Definitions contained in NSTS 22206, Instructions For Preparation of FMEA/CIL, 10 October 1986, were used with the following amplifications and additions.

INTACT ABORT DEFINITIONS:

RTLS - begins at transition to OPS 6 and ends at transition to OPS 9, post-flight

TAL - begins at declaration of the abort and ends at transition to OPS 9, post-flight

AOA - begins at declaration of the abort and ends at transition to OPS 9, post-flight

ATO - begins at declaration of the abort and ends at transition to OPS 9, post-flight

CREDIBLE (CAUSE) - an event that can be predicted or expected in anticipated operational environmental conditions. Excludes an event where multiple failures must first occur to result in environmental extremes

CONTINGENCY CREW PROCEDURES - procedures that are utilized beyond the standard malfunction procedures, pocket checklists, and cue cards

EARLY MISSION TERMINATION - termination of onorbit phase prior to planned end of mission

EFFECTS/RATIONALE - description of the case which generated the highest criticality

HIGHEST CRITICALITY - the highest functional criticality determined in the phase-by-phase analysis

MAJOR MODE (MM) - major sub-mode of software operational sequence (OPS)

MC - Memory Configuration of Primary Avionics Software System (PASS)

MISSION - assigned performance of a specific Orbiter flight with payload/objective accomplishments including orbit phasing and altitude (excludes secondary payloads such as GAS cans, middeck P/L, etc.)

MULTIPLE ORDER FAILURE - describes the failure due to a single cause or event of all units which perform a necessary (critical) function

OFF-NOMINAL CREW PROCEDURES - procedures that are utilized beyond the standard malfunction procedures, pocket checklists, and cue cards

OPS - software operational sequence

PRIMARY MISSION OBJECTIVES - worst case primary mission objectives are equal to mission objectives

PHASE DEFINITIONS:

PRELAUNCH PHASE - begins at launch count-down Orbiter power-up and ends at moding to OPS Major Mode 102 (liftoff)

LIFTOFF MISSION PHASE - begins at SRB ignition (MM 102) and ends at transition out of OPS 1 (Synonymous with ASCENT)

ONORBIT PHASE - begins at transition to OPS 2 or OPS 8 and ends at transition out of OPS 2 or OPS 8

DEORBIT PHASE - begins at transition to OPS Major Mode 301 and ends at first main landing gear touchdown

LANDING/SAFING PHASE - begins at first main gear touchdown and ends with the completion of post-landing safing operations

APPENDIX B
DEFINITIONS, GROUND RULES, AND ASSUMPTIONS

B.2 IOA Project Level Ground Rules and Assumptions

The philosophy embodied in NSTS 22206, Instructions for Preparation of FMEA/CIL, 10 October 1986, was employed with the following amplifications and additions.

1. The operational flight software is an accurate implementation of the Flight System Software Requirements (FSSRs).

RATIONALE: Software verification is out-of-scope of this task.

2. After liftoff, any parameter which is monitored by system management (SM) or which drives any part of the Caution and Warning System (C&W) will support passage of Redundancy Screen B for its corresponding hardware item.

RATIONALE: Analysis of on-board parameter availability and/or the actual monitoring by the crew is beyond the scope of this task.

3. Any data employed with flight software is assumed to be functional for the specific vehicle and specific mission being flown.

RATIONALE: Mission data verification is out-of-scope of this task.

4. All hardware (including firmware) is manufactured and assembled to the design specifications/drawings.

RATIONALE: Acceptance and verification testing is designed to detect and identify problems before the item is approved for use.

5. All Flight Data File crew procedures will be assumed performed as written, and will not include human error in their performance.

RATIONALE: Failures caused by human operational error are out-of-scope of this task.

6. All hardware analyses will, as a minimum, be performed at the level of analysis existent within NASA/Prime Contractor Orbiter FMEA/CILs, and will be permitted to go to greater hardware detail levels but not lesser.

RATIONALE: Comparison of IOA analysis results with other analyses requires that both analyses be performed to a comparable level of detail.

7. Verification that a telemetry parameter is actually monitored during AOS by ground-based personnel is not required.

RATIONALE: Analysis of mission-dependent telemetry availability and/or the actual monitoring of applicable data by ground-based personnel is beyond the scope of this task.

8. The determination of criticalities per phase is based on the worst case effect of a failure for the phase being analyzed. The failure can occur in the phase being analyzed or in any previous phase, whichever produces the worst case effects for the phase of interest.

RATIONALE: Assigning phase criticalities ensures a thorough and complete analysis.

9. Analysis of wire harnesses, cables, and electrical connectors to determine if FMEAs are warranted will not be performed nor FMEAs assessed.

RATIONALE: Analysis was substantially complete prior to NSTS 22206 ground rule redirection.

10. Analysis of welds or brazed joints that cannot be inspected will not be performed nor FMEAs assessed.

RATIONALE: Analysis was substantially complete prior to NSTS 22206 ground rule redirection.

11. Emergency system or hardware will include burst discs and will exclude the EMU Secondary Oxygen Pack (SOP), pressure relief valves and the landing gear pyrotechnics.

RATIONALE: Clarify definition of emergency systems to ensure consistency throughout IOA project.

APPENDIX B
DEFINITIONS, GROUND RULES, AND ASSUMPTIONS

B.3 RMS-Specific Ground Rules and Assumptions

The IOA analysis was performed to the component or assembly level. The analysis considered the worst case effects of the hardware or functional failure on the subsystem, mission, and crew and vehicle safety.

1. A RMS mission is considered to be uncradling, grappling a berthed payload, unberthing it, deploying it and then retrieving a rotating payload, berthing it and performing MFR operations. Any failure that prevents the completion of any of these tasks is loss of mission (i.e. loss of manual augmented modes).

RATIONALE: This is the most demanding nominal RMS mission possible. This causes the worst case criticalities for certain failures because they will prevent the completion of this mission. If the mission was simpler, many failures would be a lower criticality.

2. Consistency checking and safing is not considered redundancy for failures that cause uncommanded motion.

RATIONALE: The consistency check and safing are not redundant for the hardware that when fails causes uncommanded motion. They are also only designed to stop the RMS in 2 feet, which may not prevent collision.

3. A Criticality 1 failure is considered to be any failure that causes uncommanded motion, uncommanded release, uncommanded derigidization, or loss of capability to move a joint or any number of joints. It also includes the loss of the ability to release a payload, and the payload hanging up in the snares.

RATIONALE: Uncommanded motion in its worst case can cause the loss of vehicle if the arm or payload struck a window or damaged the payload bay doors so they could not close. Uncommanded release could cause the payload to hit the Orbiter, uncommanded derigidization or a payload hanging up in the snares can cause the unrestrained payload on the end effector to swing into the Orbiter. The loss of the ability to move a joint or release a payload would mean the RMS could not be cradled which would prevent the doors from closing.

4. The loss of primary modes will cause loss of mission (Criticality 2) but backup is considered redundancy for release of the payload and cradling the RMS for some failures. Therefore, loss of primary modes is a criticality 2 as long as backup is available.

RATIONALE: Without primary modes the RMS mission cannot be accomplished. Backup mode does not provide enough redundancy to accomplish the task mentioned in rule 1. Backup does provide some redundancy for failures that cause loss of payload release or loss of joint drive. Therefore, the failures that backup provides redundancy for will be classified as loss of mission.

5. For ascent, entry and aborts, the RMS is assumed to be cradled, latched, and unpowered. Only failures that can occur while the RMS is in this mode are considered for those flight phases.

RATIONALE: The RMS is designed for use while onorbit. During ascent and entry the RMS is latched and unpowered. No consideration will be given to failures unless they have an effect during ascent and entry.

6. Failure modes are assumed to occur during two arm operations. If a failure can effect two arms, then the worst case result of that effect will determine the criticality.

RATIONALE: The Orbiter is capable of supporting dual arm operation. If this configuration proves to be the worst case for a particular failure, then that will drive the criticality.

7. Failures of wire harnesses and bundles (structural failures, wire to wire shorts, incorrect attachment) are not considered. Failures of a single wire are covered by considering loss of input or output from a component.

RATIONALE: The failure of wire harnesses and bundles are not being considered because of the magnitude of possible failures.

**APPENDIX C
DETAILED ASSESSMENT**

This section contains the IOA assessment worksheets generated during the assessment of this subsystem. The information on these worksheets facilitates the comparison of the NASA FMEA/CIL (Pre and Post 51-L) to the IOA detailed analysis worksheets included in Appendix E. Each of these worksheets identifies the NASA FMEA being assessed, corresponding MDAC Analysis Worksheet ID (Appendix E), hardware item, criticality, redundancy screens, and recommendations. For each failure mode, the highest assessed hardware and functional criticality is compared and discrepancies noted as "N" in the compare row under the column where the discrepancy occurred.

LEGEND FOR IOA ASSESSMENT WORKSHEETS

Hardware Criticalities:

- 1 = Loss of life or vehicle
- 2 = Loss of mission or next failure of any redundant item (like or unlike) could cause loss of life/vehicle
- 3 = All others

Functional Criticalities:

- 1R = Redundant hardware items (like or unlike) all of which, if failed, could cause loss of life or vehicle
- 2R = Redundant hardware items (like or unlike) all of which, if failed, could cause loss of mission

Redundancy Screens A, B and C:

- P = Passed Screen
- F = Failed Screen
- NA = Not Applicable

NASA Data :

- Baseline = NASA FMEA/CIL
- New = Baseline with Proposed Post 51-L Changes

CIL Item :

- X = Included in CIL

Compare Row :

- N = Non compare for that column (deviation)

APPENDIX C
ASSESSMENT WORKSHEET

ASSESSMENT DATE: 1/12/88
 ASSESSMENT ID: RMS-4002
 NASA FMEA #: 05-6IA-2028-5

NASA DATA:
 BASELINE []
 NEW [X]

SUBSYSTEM: RMS/EPD&C
 MDAC ID: 4002
 ITEM: SWITCH, S4

LEAD ANALYST: ROBINSON

ASSESSMENT:

	CRITICALITY FLIGHT HDW/FUNC	REDUNDANCY SCREENS			CIL ITEM
		A	B	C	
NASA	[1 / 1]	[]	[]	[]	[X] *
IOA	[1 / 1]	[]	[]	[]	[X]
COMPARE	[/]	[]	[]	[]	[]

RECOMMENDATIONS: (If different from NASA)

[/] [] [] [] []
 (ADD/DELETE)

* CIL RETENTION RATIONALE: (If applicable)

ADEQUATE []
 INADEQUATE []

REMARKS:

IOA CONCURS WITH NASA FMEA. NO ISSUE.

APPENDIX C
ASSESSMENT WORKSHEET

ASSESSMENT DATE: 2/01/88
 ASSESSMENT ID: RMS-4003
 NASA FMEA #: 05-6IA-2028-1X

NASA DATA:
 BASELINE []
 NEW [X]

SUBSYSTEM: RMS/EPD&C
 MDAC ID: 4003
 ITEM: SWITCH, S4

LEAD ANALYST: ROBINSON

ASSESSMENT:

	CRITICALITY FLIGHT HDW/FUNC	REDUNDANCY SCREENS			CIL ITEM
		A	B	C	
NASA	[/]	[]	[]	[]	[] *
IOA	[2 / 2]	[]	[]	[]	[X]
COMPARE	[N / N]	[]	[]	[]	[N]

RECOMMENDATIONS: (If different from NASA)

[2 / 2] [] [] [] [X]
 (ADD/DELETE)

* CIL RETENTION RATIONALE: (If applicable)

ADEQUATE []
 INADEQUATE []

REMARKS:

THERE ARE THREE NASA FMEAs FOR THIS COMPONENT: 1) 05-6IA-2028-5 (FAIL OPEN, SHORTED BETWEEN POLES, SHORTED TO GROUND) WITH A CRIT OF 1/1 (REFER 4002). 2) 05-6IA-2028-6 (ONE OR MORE SETS OF CONTACTS FAIL CLOSED, PREMATURE CLOSE) WITH A CRIT OF 2/1R (REFER 4006). 3) 05-6IA-2028-9 (POLE TO POLE SHORT, CONTACT TO CONTACT SHORT, SHORT TO CASE) WITH A CRIT OF 1/1 (REFER 4002). THE FAILURE MODE IDENTIFIED IN THIS FMEA IS A CREDIBLE FAILURE AND THE FIRST FAILURE WOULD CAUSE LOSS OF MISSION (A SINGLE SWITCH TO PROVIDE BOTH PRIMARY AND BACKUP POWER). IOA RECOMMENDS THAT A NASA FMEA BE GENERATED FOR THESE COMBINED IOA FAILURE MODES(4001, 4003 AND 4004) WITH THIS CRITICALITY. NO ISSUE ON THIS IOA FMEA, REFER TO 4001 FOR RESOLUTION.

APPENDIX C
ASSESSMENT WORKSHEET

ASSESSMENT DATE: 2/01/88
 ASSESSMENT ID: RMS-4004
 NASA FMEA #: 05-6IA-2028-1X

NASA DATA:
 BASELINE []
 NEW [X]

SUBSYSTEM: RMS/EPD&C
 MDAC ID: 4004
 ITEM: SWITCH, S4

LEAD ANALYST: ROBINSON

ASSESSMENT:

	CRITICALITY FLIGHT HDW/FUNC	REDUNDANCY SCREENS			CIL ITEM
		A	B	C	
NASA	[/]	[]	[]	[]	[] *
IOA	[2 / 2]	[]	[]	[]	[X]
COMPARE	[N / N]	[]	[]	[]	[N]

RECOMMENDATIONS: (If different from NASA)

[2 / 2] [] [] [] [X]
 (ADD/DELETE)

* CIL RETENTION RATIONALE: (If applicable)

ADEQUATE []
 INADEQUATE []

REMARKS:

THERE ARE THREE NASA FMEAs FOR THIS COMPONENT: 1) 05-6IA-2028-5 (FAIL OPEN, SHORTED BETWEEN POLES, SHORTED TO GROUND) WITH A CRIT OF 1/1 (REFER 4002). 2) 05-6IA-2028-6 (ONE OR MORE SETS OF CONTACTS FAIL CLOSED, PREMATURE CLOSE) WITH A CRIT OF 2/1R (REFER 4006). 3) 05-6IA-2028-9 (POLE TO POLE SHORT, CONTACT TO CONTACT SHORT, SHORT TO CASE) WITH A CRIT OF 1/1 (REFER 4002). THE FAILURE MODE IDENTIFIED IN THIS FMEA IS A CREDIBLE FAILURE AND THE FIRST FAILURE WOULD CAUSE LOSS OF MISSION (A SINGLE SWITCH TO PROVIDE BOTH PRIMARY AND BACKUP POWER). IOA RECOMMENDS THAT A NASA FMEA BE GENERATED FOR THESE COMBINED IOA FAILURE MODES(4001, 4003 AND 4004) WITH THIS CRITICALITY. NO ISSUE ON THIS IOA FMEA, REFER TO 4001 FOR RESOLUTION.

APPENDIX C
ASSESSMENT WORKSHEET

ASSESSMENT DATE: 2/01/88
 ASSESSMENT ID: RMS-4005
 NASA FMEA #: 05-6IA-2028-2X

NASA DATA:
 BASELINE []
 NEW [X]

SUBSYSTEM: RMS/EPD&C
 MDAC ID: 4005
 ITEM: SWITCH, S4

LEAD ANALYST: ROBINSON

ASSESSMENT:

	CRITICALITY FLIGHT HDW/FUNC	REDUNDANCY SCREENS			CIL ITEM
		A	B	C	
NASA	[/]	[]	[]	[]	[] *
IOA	[2 /1R]	[P]	[NA]	[NA]	[X]
COMPARE	[N /N]	[N]	[N]	[N]	[N]

RECOMMENDATIONS: (If different from NASA)

[2 /1R] [] [] [] [X]
 (ADD/DELETE)

* CIL RETENTION RATIONALE: (If applicable)

ADEQUATE []
 INADEQUATE []

REMARKS:

THERE ARE THREE NASA FMEAs FOR THIS COMPONENT: 1) 05-6IA-2028-5 (FAIL OPEN, SHORTED BETWEEN POLES, SHORTED TO GROUND) WITH A CRIT OF 1/1 (REFER 4002). 2) 05-6IA-2028-6 (ONE OR MORE SETS OF CONTACTS FAIL CLOSED, PREMATURE CLOSE) WITH A CRIT OF 2/1R (REFER 4006). 3) 05-6IA-2028-9 (POLE TO POLE SHORT, CONTACT TO CONTACT SHORT, SHORT TO CASE) WITH A CRIT OF 1/1 (REFER 4002). THE FAILURE MODE IDENTIFIED IN THIS FMEA IS A CREDIBLE FAILURE AND THE FIRST FAILURE WOULD CAUSE LOSS OF MISSION (A SINGLE SWITCH TO PROVIDE BOTH PRIMARY AND BACKUP POWER). IOA RECOMMENDS THAT A NASA FMEA BE GENERATED WITH THIS FAILURE MODE AND CRIT.

APPENDIX C
ASSESSMENT WORKSHEET

ASSESSMENT DATE: 2/01/88
 ASSESSMENT ID: RMS-4006
 NASA FMEA #: 05-6IA-2028-6

NASA DATA:
 BASELINE []
 NEW [X]

SUBSYSTEM: RMS/EPD&C
 MDAC ID: 4006
 ITEM: SWITCH, S4

LEAD ANALYST: ROBINSON

ASSESSMENT:

	CRITICALITY FLIGHT HDW/FUNC	REDUNDANCY SCREENS			CIL ITEM
		A	B	C	
NASA	[2 /1R]	[P]	[F]	[P]	[X] *
IOA	[3 /3]	[]	[]	[]	[]
COMPARE	[N /N]	[N]	[N]	[N]	[N]

RECOMMENDATIONS: (If different from NASA)

[/] [] [] [] []
 (ADD/DELETE)

* CIL RETENTION RATIONALE: (If applicable)

ADEQUATE []
 INADEQUATE []

REMARKS:

IOA CONCURS WITH NASA FMEA. UPGRADE IOA CRIT AND SCREENS OF IOA FMEA.

APPENDIX C
ASSESSMENT WORKSHEET

ASSESSMENT DATE: 1/12/88	NASA DATA:
ASSESSMENT ID: RMS-4007	BASELINE []
NASA FMEA #: 05-6IA-2029-5	NEW [X]

SUBSYSTEM: RMS/EPD&C
MDAC ID: 4007
ITEM: SWITCH, S1

LEAD ANALYST: ROBINSON

ASSESSMENT:

	CRITICALITY FLIGHT HDW/FUNC	REDUNDANCY SCREENS			CIL ITEM
		A	B	C	
NASA	[2 /1R]	[P]	[F]	[P]	[X] *
IOA	[2 /2]	[]	[]	[]	[X]
COMPARE	[/N]	[N]	[N]	[N]	[]

RECOMMENDATIONS: (If different from NASA)

[/] [] [] [] []
(ADD/DELETE)

* CIL RETENTION RATIONALE: (If applicable)

ADEQUATE []
INADEQUATE []

REMARKS:

NO ISSUE. NASA FMEA 05-6IA-2029-5, FAILURE MODES OF FAILS OPEN, PREMATURE OPEN, SHORTS TO CASE APPEAR TO BE CREDIBLE. RECOMMEND UPGRADING THE IOA FMEA TO AGREE WITH THE NASA FMEA.

APPENDIX C
ASSESSMENT WORKSHEET

ASSESSMENT DATE: 1/12/88
 ASSESSMENT ID: RMS-4008
 NASA FMEA #: 05-6IA-2029-5

NASA DATA:
 BASELINE []
 NEW [X]

SUBSYSTEM: RMS/EPD&C
 MDAC ID: 4008
 ITEM: SWITCH, S1

LEAD ANALYST: ROBINSON

ASSESSMENT:

	CRITICALITY FLIGHT HDW/FUNC	REDUNDANCY SCREENS			CIL ITEM
		A	B	C	
NASA	[1 / 1]	[]	[]	[]	[X] *
IOA	[1 / 1]	[]	[]	[]	[X]
COMPARE	[/]	[]	[]	[]	[]

RECOMMENDATIONS: (If different from NASA)

[/] [] [] [] []
 (ADD/DELETE)

* CIL RETENTION RATIONALE: (If applicable)

ADEQUATE []
 INADEQUATE []

REMARKS:
 NONE

APPENDIX C
ASSESSMENT WORKSHEET

ASSESSMENT DATE: 1/12/88
 ASSESSMENT ID: RMS-4009
 NASA FMEA #: 05-6IA-2029-5

NASA DATA:
 BASELINE []
 NEW [X]

SUBSYSTEM: RMS/EPD&C
 MDAC ID: 4009
 ITEM: SWITCH, S1

LEAD ANALYST: ROBINSON

ASSESSMENT:

	CRITICALITY FLIGHT HDW/FUNC	REDUNDANCY SCREENS			CIL ITEM
		A	B	C	
NASA	[1 / 1]	[]	[]	[]	[X] *
IOA	[1 / 1]	[]	[]	[]	[X]
COMPARE	[/]	[]	[]	[]	[]

RECOMMENDATIONS: (If different from NASA)

[/] [] [] [] []
 (ADD/DELETE)

* CIL RETENTION RATIONALE: (If applicable)

ADEQUATE []
 INADEQUATE []

REMARKS:
 NONE

APPENDIX C
ASSESSMENT WORKSHEET

ASSESSMENT DATE: 1/12/88
 ASSESSMENT ID: RMS-4010
 NASA FMEA #: 05-6IA-2026-1

NASA DATA:
 BASELINE []
 NEW [X]

SUBSYSTEM: RMS/EPD&C
 MDAC ID: 4010
 ITEM: SWITCH, S8

LEAD ANALYST: ROBINSON

ASSESSMENT:

	CRITICALITY FLIGHT HDW/FUNC	REDUNDANCY SCREENS			CIL ITEM
		A	B	C	
NASA	[2 /1R]	[P]	[F]	[P]	[X] *
IOA	[2 /1R]	[]	[P]	[P]	[X]
COMPARE	[/]	[N]	[N]	[]	[]

RECOMMENDATIONS: (If different from NASA)

[/] [] [] [] []
 (ADD/DELETE)

* CIL RETENTION RATIONALE: (If applicable)

ADEQUATE []
 INADEQUATE []

REMARKS:

CORRECT IOA SCREENS. S7 IN RMS-4013, S8 IN RMS-4010, S9 IN RMS-4014, S10 IN RMS-4011. ALL 4 FMEAS ARE ESSENTIALLY IDENTICAL. IOA RECOMMENDS ONE FMEA FOR FOUR IDENTICAL SWITCHES AS IN NASA FMEA. IOA CONCURS THAT SCREENS SHOULD BE AS PER NASA FMEA.

APPENDIX C
ASSESSMENT WORKSHEET

ASSESSMENT DATE: 1/12/88
 ASSESSMENT ID: RMS-4011
 NASA FMEA #: 05-6IA-2026-1

NASA DATA:
 BASELINE []
 NEW [X]

SUBSYSTEM: RMS/EPD&C
 MDAC ID: 4011
 ITEM: SWITCH, S10

LEAD ANALYST: ROBINSON

ASSESSMENT:

	CRITICALITY FLIGHT HDW/FUNC	REDUNDANCY SCREENS			CIL ITEM
		A	B	C	
NASA	[2 /1R]	[P]	[F]	[P]	[X] *
IOA	[2 /1R]	[]	[P]	[P]	[X]
COMPARE	[/]	[N]	[N]	[]	[]

RECOMMENDATIONS: (If different from NASA)

[/] [] [] [] []
 (ADD/DELETE)

* CIL RETENTION RATIONALE: (If applicable)

ADEQUATE []
 INADEQUATE []

REMARKS:

CORRECT IOA FMEA SCREENS. S7 IN RMS-4013, S8 IN RMS-4010, S9 IN RMS-4014, S10 IN RMS-4011. ALL 4 FMEAS ARE ESSENTIALLY IDENTICAL. IOA RECOMMENDS ONE FMEA FOR FOUR IDENTICAL SWITCHES AS IN NASA FMEA. IOA CONCURS THAT SCREENS SHOULD BE AS PER NASA FMEA.

APPENDIX C
ASSESSMENT WORKSHEET

ASSESSMENT DATE: 1/12/88
 ASSESSMENT ID: RMS-4012
 NASA FMEA #: 05-6IA-2026-2

NASA DATA:
 BASELINE []
 NEW [X]

SUBSYSTEM: RMS/EPD&C
 MDAC ID: 4012
 ITEM: SWITCHES, S8, S10

LEAD ANALYST: ROBINSON

ASSESSMENT:

	CRITICALITY FLIGHT HDW/FUNC	REDUNDANCY SCREENS			CIL ITEM
		A	B	C	
NASA	[3 /1R]	[P]	[F]	[P]	[X] *
IOA	[2 /2]	[]	[]	[]	[X]
COMPARE	[N /N]	[N]	[N]	[N]	[]

RECOMMENDATIONS: (If different from NASA)

[/] [] [] [] []
 (ADD/DELETE)

* CIL RETENTION RATIONALE: (If applicable)

ADEQUATE []
 INADEQUATE []

REMARKS:

UPGRADE CRIT OF IOA FMEA, COMBINE IOA COMPONENTS NASA ANALYSIS STATES THAT CONTINUOUSLY POWERING HEATING ELEMENTS COULD INCREASE TEMPERATURES SUFFICIENTLY TO PREVENT RMS JOINT MOVEMENTS. IT WOULD APPEAR THE FAILURE MODE IS CREDIBLE (ALBEIT UNLIKELY) THEREFORE IOA CONCURS WITH NASA FMEA. RECOMMEND COMBINING 4012 AND 4015.

APPENDIX C
ASSESSMENT WORKSHEET

ASSESSMENT DATE: 1/12/88
 ASSESSMENT ID: RMS-4013
 NASA FMEA #: 05-6IA-2026-1

NASA DATA:
 BASELINE []
 NEW [X]

SUBSYSTEM: RMS/EPD&C
 MDAC ID: 4013
 ITEM: SWITCH, S7

LEAD ANALYST: ROBINSON

ASSESSMENT:

	CRITICALITY FLIGHT HDW/FUNC	REDUNDANCY SCREENS			CIL ITEM
		A	B	C	
NASA	[2 /1R]	[P]	[F]	[P]	[X] *
IOA	[2 /1R]	[]	[P]	[P]	[X]
COMPARE	[/]	[N]	[N]	[]	[]

RECOMMENDATIONS: (If different from NASA)

[/] [] [] [] []
 (ADD/DELETE)

* CIL RETENTION RATIONALE: (If applicable)

ADEQUATE []
 INADEQUATE []

REMARKS:

CORRECT IOA SCREEN, COMBINE IOA FMEAS S7 IN RMS-4013, S8 IN RMS-4010, S9 IN RMS-4014, S10 IN RMS-4011. ALL 4 FMEAS ARE ESSENTIALLY IDENTICAL. IOA RECOMMENDS ONE FMEA FOR FOUR IDENTICAL SWITCHES AS IN POST FMEA. IOA CONCURS THAT THE SCREENS SHOULD BE AS PER NASA FMEA.

APPENDIX C
ASSESSMENT WORKSHEET

ASSESSMENT DATE: 1/12/88
 ASSESSMENT ID: RMS-4014
 NASA FMEA #: 05-6IA-2026-1

NASA DATA:
 BASELINE []
 NEW [X]

SUBSYSTEM: RMS/EPD&C
 MDAC ID: 4014
 ITEM: SWITCH, S9

LEAD ANALYST: ROBINSON

ASSESSMENT:

	CRITICALITY FLIGHT HDW/FUNC	REDUNDANCY SCREENS			CIL ITEM
		A	B	C	
NASA	[2 /1R]	[P]	[F]	[P]	[X] *
IOA	[2 /1R]	[]	[P]	[P]	[X]
COMPARE	[/]	[N]	[N]	[]	[]

RECOMMENDATIONS: (If different from NASA)

[/] [] [] [] []
 (ADD/DELETE)

* CIL RETENTION RATIONALE: (If applicable)

ADEQUATE []
 INADEQUATE []

REMARKS:

NO ISSUE. CORRECT IOA SCREEN, COMBINE IOA FMEAS S7 IN RMS-4013, S8 IN RMS-4010, S9 IN RMS-4014, S10 IN RMS-4011. ALL 4 FMEAS ARE ESSENTIALLY IDENTICAL. IOA RECOMMENDS ONE FMEA FOR FOUR IDENTICAL SWITCHES AS IN POST FMEA.

APPENDIX C
ASSESSMENT WORKSHEET

ASSESSMENT DATE: 1/12/88
 ASSESSMENT ID: RMS-4015
 NASA FMEA #: 05-6IA-2026-2

NASA DATA:
 BASELINE []
 NEW [X]

SUBSYSTEM: RMS/EPD&C
 MDAC ID: 4015
 ITEM: SWITCHES, S7, S9

LEAD ANALYST: ROBINSON

ASSESSMENT:

	CRITICALITY FLIGHT HDW/FUNC	REDUNDANCY SCREENS			CIL ITEM
		A	B	C	
NASA	[3 /1R]	[P]	[F]	[P]	[X] *
IOA	[2 /2]	[]	[]	[]	[X]
COMPARE	[N /N]	[N]	[N]	[N]	[]

RECOMMENDATIONS: (If different from NASA)

[/] [] [] [] []
 (ADD/DELETE)

* CIL RETENTION RATIONALE: (If applicable)

ADEQUATE []
 INADEQUATE []

REMARKS:

DOWNGRADE IOA CRIT, CHANGE IOA SCREENS, COMBINE IOA FMEAS POST ANALYSIS STATES THAT CONTINUOUSLY POWERING HEATING ELEMENTS COULD INCREASE TEMPERATURES SUFFICIENTLY TO PREVENT RMS JOINT MOVEMENTS. IT WOULD APPEAR THE FAILURE MODE IS CREDIBLE (ALBEIT UNLIKELY) THEREFORE IOA CONCURS WITH NASA FMEA. RECOMMEND COMBINING RMS-4012 AND RMS-4015 INTO RMS-4012 WITH THE APPROPRIATE SCREENS.

APPENDIX C
ASSESSMENT WORKSHEET

ASSESSMENT DATE: 1/12/88
 ASSESSMENT ID: RMS-4016
 NASA FMEA #: 05-6IA-2003-1

NASA DATA:
 BASELINE []
 NEW [X]

SUBSYSTEM: RMS/EPD&C
 MDAC ID: 4016
 ITEM: FUSE, F1

LEAD ANALYST: ROBINSON

ASSESSMENT:

	CRITICALITY FLIGHT HDW/FUNC	REDUNDANCY SCREENS			CIL ITEM
		A	B	C	
NASA	[1 / 1]	[]	[]	[]	[X] *
IOA	[2 / 2]	[]	[]	[]	[X]
COMPARE	[N / N]	[]	[]	[]	[]

RECOMMENDATIONS: (If different from NASA)

[/] [] [] [] []
 (ADD/DELETE)

* CIL RETENTION RATIONALE: (If applicable)

ADEQUATE []
 INADEQUATE []

REMARKS:

COMBINE IOA FAILURE MODES. NO ISSUE. THIS FMEA APPEARS TO BE REDUNDANT TO RMS-4017. REFERENCE NSTS 22206 PAR 2.3.4B FOR BLANK REDUNDANCY SCREEN REQUIREMENT SINCE RMS-4017 FAILS THE FUSE OPEN AT A MORE CRITICAL TIME WITH A CRIT 2/1R, AND THIS FAILURE DIFFERS ONLY IN THAT IT OCCURS AT A LESS CRITICAL TIME, IOA RECOMMENDS IT BE ABSORBED INTO RMS-4017.

APPENDIX C
ASSESSMENT WORKSHEET

ASSESSMENT DATE: 1/12/88	NASA DATA:
ASSESSMENT ID: RMS-4017	BASELINE []
NASA FMEA #: 05-6IA-2003-1	NEW [X]

SUBSYSTEM: RMS/EPD&C
MDAC ID: 4017
ITEM: FUSE, F1

LEAD ANALYST: ROBINSON

ASSESSMENT:

	CRITICALITY FLIGHT HDW/FUNC	REDUNDANCY SCREENS			CIL ITEM
		A	B	C	
NASA	[1 /1]	[]	[]	[]	[X] *
IOA	[2 /1R]	[P]	[NA]	[NA]	[X]
COMPARE	[N /N]	[N]	[N]	[N]	[]

RECOMMENDATIONS: (If different from NASA)

[/]	[]	[]	[]	[]	(ADD/DELETE)
-------------	--------	--------	--------	--------	--------------

* CIL RETENTION RATIONALE: (If applicable)

ADEQUATE	[]
INADEQUATE	[]

REMARKS:

NO ISSUE. IOA CONCURS THAT THIS FAILURE COULD CAUSE UNCOMMANDED MOTION WHICH IS CONSIDERED TO BE POSSIBLY CATASTROPHIC.
UPGRADE IOA CRIT.

APPENDIX C
ASSESSMENT WORKSHEET

ASSESSMENT DATE: 1/12/88
 ASSESSMENT ID: RMS-4018
 NASA FMEA #: 05-6IA-2002-1

NASA DATA:
 BASELINE []
 NEW [X]

SUBSYSTEM: RMS/EPD&C
 MDAC ID: 4018
 ITEM: FUSE, F2

LEAD ANALYST: ROBINSON

ASSESSMENT:

	CRITICALITY FLIGHT HDW/FUNC	REDUNDANCY SCREENS			CIL ITEM
		A	B	C	
NASA	[3 /1R]	[P]	[P]	[P]	[] *
IOA	[2 /2]	[]	[]	[]	[X]
COMPARE	[N /N]	[N]	[N]	[N]	[N]

RECOMMENDATIONS: (If different from NASA)

[/] [] [] [] []
 (ADD/DELETE)

* CIL RETENTION RATIONALE: (If applicable)

ADEQUATE []
 INADEQUATE []

REMARKS:

COMBINE IOA FAILURE MODES. NO ISSUE. IOA RECOMMENDS THAT THIS FMEA BE COMBINED WITH RMS-4019.

APPENDIX C
ASSESSMENT WORKSHEET

ASSESSMENT DATE: 1/12/88
 ASSESSMENT ID: RMS-4019
 NASA FMEA #: 05-6IA-2002-1

NASA DATA:
 BASELINE []
 NEW [X]

SUBSYSTEM: RMS/EPD&C
 MDAC ID: 4019
 ITEM: FUSE, F2

LEAD ANALYST: ROBINSON

ASSESSMENT:

	CRITICALITY FLIGHT HDW/FUNC	REDUNDANCY SCREENS			CIL ITEM
		A	B	C	
NASA	[3 /1R]	[P]	[P]	[P]	[] *
IOA	[2 /1R]	[P]	[NA]	[NA]	[X]
COMPARE	[N /]	[]	[N]	[N]	[N]

RECOMMENDATIONS: (If different from NASA)

[2 /1R] [P] [NA] [P] [X]
 (ADD/DELETE)

* CIL RETENTION RATIONALE: (If applicable)

ADEQUATE []
 INADEQUATE []

REMARKS:

UPGRADE NASA CRIT, CORRECT IOA SCREENS, COMBINE IOA FMEAS.
 REDUNDANCY SCREEN B IS NOT APPLICABLE FOR STANDBY REDUNDANT
 ITEMS. CHANGE IOA SCREEN C TO "P". IOA SCREENS SHOULD BE 1 -
 N/A - P. BACKUP POWER WOULD ONLY BE USED AFTER PRIMARY FAILURE.
 LOSS OF BACKUP POWER UNDER SUCH CONDITIONS COULD CAUSE LOSS OF
 CREW/VEHICLE IF ARM CANNOT BE SAFELY STOWED OR JETTISONED. IOA
 RECOMMENDS THAT RMS-4018 BE COMBINED WITH THIS FMEA WITH CHANGED
 SCREENS.

APPENDIX C
ASSESSMENT WORKSHEET

ASSESSMENT DATE: 1/12/88
 ASSESSMENT ID: RMS-4020
 NASA FMEA #: 05-6IA-2076-1

NASA DATA:
 BASELINE []
 NEW [X]

SUBSYSTEM: RMS/EPD&C
 MDAC ID: 4020
 ITEM: RESISTOR, A3R2

LEAD ANALYST: ROBINSON

ASSESSMENT:

	CRITICALITY FLIGHT HDW/FUNC	REDUNDANCY SCREENS			CIL ITEM
		A	B	C	
NASA	[2 /1R]	[P]	[F]	[P]	[X] *
IOA	[3 /2R]	[]	[P]	[P]	[]
COMPARE	[N /N]	[N]	[N]	[]	[N]

RECOMMENDATIONS: (If different from NASA)

[/] [] [] [] []
 (ADD/DELETE)

* CIL RETENTION RATIONALE: (If applicable)

ADEQUATE []
 INADEQUATE []

REMARKS:

COMBINE IOA FMEAS AND UPGRADE CRIT AND SCREENS. NASA FMEA
 COMBINES STARBOARD AND PORT COMPONENTS ON THE SAME FMEA. FOR
 REALISTIC ASSESSMENT, IOA CONCURS TO COMBINE IOA FMEAs 4021, 4022
 AND 4023 AND UPGRADE CRITs AND SCREENS ACCORDINGLY.

APPENDIX C
ASSESSMENT WORKSHEET

ASSESSMENT DATE: 1/12/88
 ASSESSMENT ID: RMS-4021
 NASA FMEA #: 05-6IA-2076-1

NASA DATA:
 BASELINE []
 NEW [X]

SUBSYSTEM: RMS/EPD&C
 MDAC ID: 4021
 ITEM: RESISTOR, A3R3

LEAD ANALYST: ROBINSON

ASSESSMENT:

	CRITICALITY FLIGHT HDW/FUNC	REDUNDANCY SCREENS			CIL ITEM
		A	B	C	
NASA	[2 /1R]	[P]	[F]	[P]	[X] *
IOA	[3 /2R]	[]	[P]	[P]	[]
COMPARE	[N /N]	[N]	[N]	[]	[N]

RECOMMENDATIONS: (If different from NASA)

[/] [] [] [] []
 (ADD/DELETE)

* CIL RETENTION RATIONALE: (If applicable)

ADEQUATE []
 INADEQUATE []

REMARKS:

COMBINE IOA FMEAS AND UPGRADE CRIT AND SCREENS. NASA FMEA COMBINES STARBOARD AND PORT COMPONENTS ON THE SAME FMEA. FOR REALISTIC ASSESSMENT, IOA CONCURS TO COMBINE IOA FMEAS 4021, 4022 AND 4023 AND UPGRADE CRITS AND SCREENS ACCORDINGLY.

APPENDIX C
ASSESSMENT WORKSHEET

ASSESSMENT DATE: 1/12/88
 ASSESSMENT ID: RMS-4022
 NASA FMEA #: 05-6IA-2076-1

NASA DATA:
 BASELINE []
 NEW [X]

SUBSYSTEM: RMS/EPD&C
 MDAC ID: 4022
 ITEM: RESISTOR, A2R2

LEAD ANALYST: ROBINSON

ASSESSMENT:

	CRITICALITY FLIGHT HDW/FUNC	REDUNDANCY SCREENS			CIL ITEM
		A	B	C	
NASA	[2 /1R]	[P]	[F]	[P]	[X] *
IOA	[3 /2R]	[]	[P]	[P]	[]
COMPARE	[N /N]	[N]	[N]	[]	[N]

RECOMMENDATIONS: (If different from NASA)

[/] [] [] [] []
 (ADD/DELETE)

* CIL RETENTION RATIONALE: (If applicable)

ADEQUATE []
 INADEQUATE []

REMARKS:

COMBINE IOA FMEAS AND UPGRADE CRIT AND SCREENS. NASA FMEA
 COMBINES STARBOARD AND PORT COMPONENTS ON THE SAME FMEA. FOR
 REALISTIC ASSESSMENT, IOA CONCURS TO COMBINE IOA FMEAS 4021, 4022
 AND 4023 AND UPGRADE CRITS AND SCREENS ACCORDINGLY.

APPENDIX C
ASSESSMENT WORKSHEET

ASSESSMENT DATE: 1/12/88
 ASSESSMENT ID: RMS-4023
 NASA FMEA #: 05-6IA-2076-1

NASA DATA:
 BASELINE []
 NEW [X]

SUBSYSTEM: RMS/EPD&C
 MDAC ID: 4023
 ITEM: RESISTOR, A2R3

LEAD ANALYST: ROBINSON

ASSESSMENT:

	CRITICALITY FLIGHT HDW/FUNC	REDUNDANCY SCREENS			CIL ITEM
		A	B	C	
NASA	[2 /1R]	[P]	[F]	[P]	[X] *
IOA	[3 /2R]	[]	[P]	[P]	[]
COMPARE	[N /N]	[N]	[N]	[]	[N]

RECOMMENDATIONS: (If different from NASA)

[/] [] [] [] []
 (ADD/DELETE)

* CIL RETENTION RATIONALE: (If applicable)

ADEQUATE []
 INADEQUATE []

REMARKS:

COMBINE IOA FMEAS AND UPGRADE CRIT AND SCREENS. NASA FMEA
 COMBINES STARBOARD AND PORT COMPONENTS ON THE SAME FMEA. FOR
 REALISTIC ASSESSMENT, IOA CONCURS TO COMBINE IOA FMEAS 4021, 4022
 AND 4023 AND UPGRADE CRITS AND SCREENS ACCORDINGLY.

APPENDIX C
ASSESSMENT WORKSHEET

ASSESSMENT DATE: 1/12/88
 ASSESSMENT ID: RMS-4024
 NASA FMEA #: 05-6IA-2078-1

NASA DATA:
 BASELINE []
 NEW [X]

SUBSYSTEM: RMS/EPD&C
 MDAC ID: 4024
 ITEM: RESISTOR, A1R1

LEAD ANALYST: ROBINSON

ASSESSMENT:

	CRITICALITY FLIGHT HDW/FUNC	REDUNDANCY SCREENS			CIL ITEM
		A	B	C	
NASA	[3 / 3]	[]	[]	[]	[] *
IOA	[3 / 3]	[]	[]	[]	[]
COMPARE	[/]	[]	[]	[]	[]

RECOMMENDATIONS: (If different from NASA)

[/] [] [] [] []
 (ADD/DELETE)

* CIL RETENTION RATIONALE: (If applicable)

ADEQUATE []
 INADEQUATE []

REMARKS:

COMBINE IOA COMPONENTS. NASA FMEA 05-6IA-2078-1 HAS THE FOUR RESISTORS LISTED IN REF DESIGNATOR. IOA FMEA 4024 FAILS RESISTOR A1R2. IOA FMEA 4025 FAILS RESISTOR A1R2. IOA FMEA 4026 FAILS RESISTOR A3R1. IOA FMEA 4027 FAILS RESISTOR A2R1. RECOMMEND COMBING IOA FMEA COMPONENTS TO AGREE WITH NASA FMEA.

APPENDIX C
ASSESSMENT WORKSHEET

ASSESSMENT DATE: 1/12/88
 ASSESSMENT ID: RMS-4026
 NASA FMEA #: 05-6IA-2078-1

NASA DATA:
 BASELINE []
 NEW [X]

SUBSYSTEM: RMS/EPD&C
 MDAC ID: 4026
 ITEM: RESISTOR, A3R1

LEAD ANALYST: ROBINSON

ASSESSMENT:

	CRITICALITY FLIGHT HDW/FUNC	REDUNDANCY SCREENS			CIL ITEM
		A	B	C	
NASA	[3 / 3]	[]	[]	[]	[] *
IOA	[3 / 3]	[]	[]	[]	[]
COMPARE	[/]	[]	[]	[]	[]

RECOMMENDATIONS: (If different from NASA)

[/] [] [] [] []
 (ADD/DELETE)

* CIL RETENTION RATIONALE: (If applicable)

ADEQUATE []
 INADEQUATE []

REMARKS:

COMBINE IOA COMPONENTS. NASA FMEA 05-6IA-2078-1 HAS THE FOUR RESISTORS LISTED IN REF DESIGNATOR. IOA FMEA 4024 FAILS RESISTOR A1R2. IOA FMEA 4025 FAILS RESISTOR A1R2. IOA FMEA 4026 FAILS RESISTOR A3R1. IOA FMEA 4027 FAILS RESISTOR A2R1. RECOMMEND COMBING IOA FMEA COMPONENTS TO AGREE WITH NASA FMEA.

APPENDIX C
ASSESSMENT WORKSHEET

ASSESSMENT DATE: 1/12/88
 ASSESSMENT ID: RMS-4027
 NASA FMEA #: 05-6IA-2078-1

NASA DATA:
 BASELINE []
 NEW [X]

SUBSYSTEM: RMS/EPD&C
 MDAC ID: 4027
 ITEM: RESISTOR, A2R1

LEAD ANALYST: ROBINSON

ASSESSMENT:

	CRITICALITY FLIGHT HDW/FUNC	REDUNDANCY SCREENS			CIL ITEM
		A	B	C	
NASA	[3 / 3]	[]	[]	[]	[] *
IOA	[3 / 3]	[]	[]	[]	[]
COMPARE	[/]	[]	[]	[]	[]

RECOMMENDATIONS: (If different from NASA)

[/] [] [] [] []
 (ADD/DELETE)

* CIL RETENTION RATIONALE: (If applicable)

ADEQUATE []
 INADEQUATE []

REMARKS:

COMBINE IOA COMPONENTS. NASA FMEA 05-6IA-2078-1 HAS THE FOUR RESISTORS LISTED IN REF DESIGNATOR. IOA FMEA 4024 FAILS RESISTOR A1R2. IOA FMEA 4025 FAILS RESISTOR A1R2. IOA FMEA 4026 FAILS RESISTOR A3R1. IOA FMEA 4027 FAILS RESISTOR A2R1. RECOMMEND COMBING IOA FMEA COMPONENTS TO AGREE WITH NASA FMEA.

APPENDIX C
ASSESSMENT WORKSHEET

ASSESSMENT DATE: 1/12/88
 ASSESSMENT ID: RMS-4028
 NASA FMEA #: 05-6IA-2006-1

NASA DATA:
 BASELINE []
 NEW [X]

SUBSYSTEM: RMS/EPD&C
 MDAC ID: 4028
 ITEM: CIRCUIT BREAKER, CB17

LEAD ANALYST: ROBINSON

ASSESSMENT:

	CRITICALITY FLIGHT HDW/FUNC	REDUNDANCY SCREENS			CIL ITEM
		A	B	C	
NASA	[2 / 2]	[]	[]	[]	[X] *
IOA	[2 / 2]	[]	[]	[]	[X]
COMPARE	[/]	[]	[]	[]	[]

RECOMMENDATIONS: (If different from NASA)

[/] [] [] [] []
 (ADD/DELETE)

* CIL RETENTION RATIONALE: (If applicable)

ADEQUATE []
 INADEQUATE []

REMARKS:

NO ISSUE. COMBINE IOA FMEAS. IOA RECOMMENDS COMBINING THIS
 FAILURE MODE INTO RMS-2029.

APPENDIX C
ASSESSMENT WORKSHEET

ASSESSMENT DATE: 1/12/88
 ASSESSMENT ID: RMS-4029
 NASA FMEA #: 05-6IA-2006-1

NASA DATA:
 BASELINE []
 NEW [X]

SUBSYSTEM: RMS/EPD&C
 MDAC ID: 4029
 ITEM: CIRCUIT BREAKER, CB17

LEAD ANALYST: ROBINSON

ASSESSMENT:

	CRITICALITY FLIGHT HDW/FUNC	REDUNDANCY SCREENS			CIL ITEM
		A	B	C	
NASA	[2 /2]	[]	[]	[]	[X] *
IOA	[2 /1R]	[]	[NA]	[NA]	[X]
COMPARE	[/N]	[]	[N]	[N]	[]

RECOMMENDATIONS: (If different from NASA)

[2 /1R] [1] [N/] [P] []
 (ADD/DELETE)

* CIL RETENTION RATIONALE: (If applicable)

ADEQUATE []
 INADEQUATE []

REMARKS:

GENERATE NASA FMEA, CHANGE IOA SCREENS, COMBINE IOA FMEAs. LOSS OF PRIMARY AC PWR WITH ARM IN USE WOULD CAUSE LOSS OF PRIMARY MODE OF OPERATION, THUS LOSS OF MISSION. ANY SUBSEQUENT FAILURE IN THE BACKUP SYSTEM COULD CAUSE LOSS OF VEHICLE/CREW IF THE ARM COULD NOT BE STOWED OR SAFELY JETTISONED. IOA REDUNDANCY SCREENS SHOULD READ: A=1 B=N/A C=P.

APPENDIX C
ASSESSMENT WORKSHEET

ASSESSMENT DATE: 1/12/88
 ASSESSMENT ID: RMS-4030
 NASA FMEA #: 05-6IA-2006-2

NASA DATA:
 BASELINE []
 NEW [X]

SUBSYSTEM: RMS/EPD&C
 MDAC ID: 4030
 ITEM: CIRCUIT BREAKER, CB17

LEAD ANALYST: ROBINSON

ASSESSMENT:

	CRITICALITY FLIGHT HDW/FUNC	REDUNDANCY SCREENS			CIL ITEM
		A	B	C	
NASA	[3 / 3]	[]	[]	[]	[] *
IOA	[3 / 3]	[]	[]	[]	[]
COMPARE	[/]	[]	[]	[]	[]

RECOMMENDATIONS: (If different from NASA)

[/] [] [] [] []
 (ADD/DELETE)

* CIL RETENTION RATIONALE: (If applicable)

ADEQUATE []
 INADEQUATE []

REMARKS:
 NONE

APPENDIX C
ASSESSMENT WORKSHEET

ASSESSMENT DATE: 1/12/88
 ASSESSMENT ID: RMS-4031
 NASA FMEA #: 05-6IA-2001-1

NASA DATA:
 BASELINE []
 NEW [X]

SUBSYSTEM: RMS/EPD&C
 MDAC ID: 4031
 ITEM: CIRCUIT BREAKER, CB19

LEAD ANALYST: ROBINSON

ASSESSMENT:

	CRITICALITY FLIGHT HDW/FUNC	REDUNDANCY SCREENS			CIL ITEM
		A	B	C	
NASA	[3 /3]	[]	[]	[]	[] *
IOA	[2 /2]	[]	[]	[]	[X]
COMPARE	[N /N]	[]	[]	[]	[N]

RECOMMENDATIONS: (If different from NASA)

[/] [] [] [] []
 (ADD/DELETE)

* CIL RETENTION RATIONALE: (If applicable)

ADEQUATE []
 INADEQUATE []

REMARKS:

COMBINE IOA FAILURE MODES. RECOMMEND COMBINING THIS MODE WITH RMS-4032 (HAS HIGHER CRIT).

APPENDIX C
ASSESSMENT WORKSHEET

ASSESSMENT DATE: 1/12/88
 ASSESSMENT ID: RMS-4032
 NASA FMEA #: 05-6IA-2001-1

NASA DATA:
 BASELINE []
 NEW [X]

SUBSYSTEM: RMS/EPD&C
 MDAC ID: 4032
 ITEM: CIRCUIT BREAKER, CB19

LEAD ANALYST: ROBINSON

ASSESSMENT:

	CRITICALITY FLIGHT HDW/FUNC	REDUNDANCY SCREENS			CIL ITEM
		A	B	C	
NASA	[3 /3]	[]	[]	[]	[] *
IOA	[2 /1R]	[P]	[NA]	[NA]	[X]
COMPARE	[N /N]	[N]	[N]	[N]	[N]

RECOMMENDATIONS: (If different from NASA)

[2 /1R] [1] [N/] [P] []
 (ADD/DELETE)

* CIL RETENTION RATIONALE: (If applicable)

ADEQUATE []
 INADEQUATE []

REMARKS:

IOA C SCREEN SHOULD BE "P" AND IOA SCREEN B IS NOT APPLICABLE SINCE BACKUP AC POWER IS STANDBY REDUNDANT PER NSTS 22206. SCREENS SHOULD BE 1 - N/A - P. RECOMMEND THIS FMEA BE COMBINED WITH RMS-4031. RECOMMEND THE NASA FMEA BE CHANGED TO AGREE WITH THE MODIFICATIONS TO THIS FMEA. LOSS OF BACKUP AC POWER WHILE IN OPERATION COULD CAUSE LOSS OF VEHICLE/CREW IF ARM COULD NOT BE SAFELY STOWED OR JETTISONED.

APPENDIX C
ASSESSMENT WORKSHEET

ASSESSMENT DATE: 1/12/88
 ASSESSMENT ID: RMS-4033
 NASA FMEA #: 05-6IA-2001-1

NASA DATA:
 BASELINE []
 NEW [X]

SUBSYSTEM: RMS/EPD&C
 MDAC ID: 4033
 ITEM: CIRCUIT BREAKER, CB19

LEAD ANALYST: ROBINSON

ASSESSMENT:

	CRITICALITY FLIGHT HDW/FUNC	REDUNDANCY SCREENS			CIL ITEM
		A	B	C	
NASA	[3 / 3]	[]	[]	[]	[] *
IOA	[3 / 3]	[]	[]	[]	[]
COMPARE	[/]	[]	[]	[]	[]

RECOMMENDATIONS: (If different from NASA)

[/] [] [] [] []
 (ADD/DELETE)

* CIL RETENTION RATIONALE: (If applicable)

ADEQUATE []
 INADEQUATE []

REMARKS:
 NO ISSUE.

APPENDIX C
ASSESSMENT WORKSHEET

ASSESSMENT DATE: 1/12/88
 ASSESSMENT ID: RMS-4034
 NASA FMEA #: 05-6IA-2126-1

NASA DATA:
 BASELINE []
 NEW [X]

SUBSYSTEM: RMS/EPD&C
 MDAC ID: 4034
 ITEM: RELAY, K1

LEAD ANALYST: ROBINSON

ASSESSMENT:

	CRITICALITY FLIGHT HDW/FUNC	REDUNDANCY SCREENS			CIL ITEM
		A	B	C	
NASA	[1 / 1]	[]	[]	[]	[X] *
IOA	[2 / 2]	[]	[]	[]	[X]
COMPARE	[N / N]	[]	[]	[]	[]

RECOMMENDATIONS: (If different from NASA)

[/] [] [] [] []
 (ADD/DELETE)

* CIL RETENTION RATIONALE: (If applicable)

ADEQUATE []
 INADEQUATE []

REMARKS:

THE NASA FMEA 05-6IA-2126-1 HAS BOTH K1 AND K2 WITH FAILURE MODES
 `FAIL OPEN', `SHORT TO GROUND'. IOA FMEAS 4034 AND 4035 HAVE K1
 FAILING OPEN AT DIFFERENT TIMES WITH CRITS 2/2 AND 2/1R
 RESPECTIVELY. IOA RECOMMENDS COMBINING THE FOUR IOA FMEAs
 4034, 4035, 4037 AND 4038 INTO ONE FMEA WITH A 1/1 CRIT.

APPENDIX C
ASSESSMENT WORKSHEET

ASSESSMENT DATE: 1/12/88
 ASSESSMENT ID: RMS-4035
 NASA FMEA #: 05-6IA-2126-1

NASA DATA:
 BASELINE []
 NEW [X]

SUBSYSTEM: RMS/EPD&C
 MDAC ID: 4035
 ITEM: RELAY, K1

LEAD ANALYST: ROBINSON

ASSESSMENT:

	CRITICALITY FLIGHT HDW/FUNC	REDUNDANCY SCREENS			CIL ITEM
		A	B	C	
NASA	[1 /1]	[]	[]	[]	[X] *
IOA	[2 /1R]	[P]	[NA]	[NA]	[X]
COMPARE	[N /N]	[N]	[N]	[N]	[]

RECOMMENDATIONS: (If different from NASA)

[/] [] [] [] []
 (ADD/DELETE)

* CIL RETENTION RATIONALE: (If applicable)

ADEQUATE []
 INADEQUATE []

REMARKS:

THE NASA FMEA 05-6IA-2126-1 HAS BOTH K1 AND K2 WITH FAILURE MODES 'FAIL OPEN', 'SHORT TO GROUND'. IOA FMEAS 4034 AND 4035 HAVE K1 FAILING OPEN AT DIFFERENT TIMES WITH CRITS 2/2 AND 2/1R RESPECTIVELY. IOA RECOMMENDS COMBINING THE FOUR IOA FMEAS 4034, 4035, 4037 AND 4038 INTO ONE FMEA WITH A 1/1 CRIT.

APPENDIX C
ASSESSMENT WORKSHEET

ASSESSMENT DATE: 2/12/99
 ASSESSMENT ID: RMS-4036
 NASA FMEA #: 05-6IA-2126-2

NASA DATA:
 BASELINE []
 NEW [X]

SUBSYSTEM: RMS/EPD&C
 MDAC ID: 4036
 ITEM: RELAY, K1

LEAD ANALYST: ROBINSON

ASSESSMENT:

	CRITICALITY FLIGHT HDW/FUNC	REDUNDANCY SCREENS			CIL ITEM
		A	B	C	
NASA	[2 /1R]	[P]	[F]	[P]	[X] *
IOA	[3 /3]	[]	[]	[]	[]
COMPARE	[N /N]	[N]	[N]	[N]	[N]

RECOMMENDATIONS: (If different from NASA)

[/] [] [] [] []
 (ADD/DELETE)

* CIL RETENTION RATIONALE: (If applicable)

ADEQUATE []
 INADEQUATE []

REMARKS:

UPGRADE IOA FMEA CRIT. NASA FMEA 05-6IA-2126-2 HAS BOTH K1 AND K2 FAIL WITH INADVERTENT OUTPUT. IOA FMEAS 4036 AND 4039 HAVE K1 FAILING CLOSED. RECOMMEND COMBINING BOTH RELAYS ON 4036 WITH THE FAILURE MODES IN AGREEMENT WITH NASA FMEA/CIL.

APPENDIX C
ASSESSMENT WORKSHEET

ASSESSMENT DATE: 1/12/88
 ASSESSMENT ID: RMS-4037
 NASA FMEA #: 05-6IA-2126-1

NASA DATA:
 BASELINE []
 NEW [X]

SUBSYSTEM: RMS/EPD&C
 MDAC ID: 4037
 ITEM: RELAY, K2

LEAD ANALYST: ROBINSON

ASSESSMENT:

	CRITICALITY FLIGHT HDW/FUNC	REDUNDANCY SCREENS			CIL ITEM
		A	B	C	
NASA	[1 /1]	[]	[]	[]	[X] *
IOA	[2 /2]	[]	[]	[]	[X]
COMPARE	[N /N]	[]	[]	[]	[]

RECOMMENDATIONS: (If different from NASA)

[/] [] [] [] []
 (ADD/DELETE)

* CIL RETENTION RATIONALE: (If applicable)

ADEQUATE []
 INADEQUATE []

REMARKS:

THE NASA FMEA 05-6IA-2126-1 HAS BOTH K1 AND K2 WITH FAILURE MODES `FAIL OPEN', `SHORT TO GROUND'. IOA FMEAS 4034 AND 4035 HAVE K1 FAILING OPEN AT DIFFERENT TIMES WITH CRITS 2/2 AND 2/1R RESPECTIVELY. IOA RECOMMENDS COMBINING THE FOUR IOA FMEAS 4034, 4035, 4037 AND 4038 INTO ONE FMEA WITH A 1/1 CRIT.

APPENDIX C
ASSESSMENT WORKSHEET

ASSESSMENT DATE: 1/12/88
 ASSESSMENT ID: RMS-4038
 NASA FMEA #: 05-6IA-2126-1

NASA DATA:
 BASELINE []
 NEW [X]

SUBSYSTEM: RMS/EPD&C
 MDAC ID: 4038
 ITEM: RELAY, K2

LEAD ANALYST: ROBINSON

ASSESSMENT:

	CRITICALITY FLIGHT HDW/FUNC	REDUNDANCY SCREENS			CIL ITEM
		A	B	C	
NASA	[1 /1]	[]	[]	[]	[X] *
IOA	[2 /1R]	[P]	[P]	[P]	[X]
COMPARE	[N /N]	[N]	[N]	[N]	[]

RECOMMENDATIONS: (If different from NASA)

[/] [] [] [] []
 (ADD/DELETE)

* CIL RETENTION RATIONALE: (If applicable)

ADEQUATE []
 INADEQUATE []

REMARKS:

THE NASA FMEA 05-6IA-2126-1 HAS BOTH K1 AND K2 WITH FAILURE MODES
 `FAIL OPEN', `SHORT TO GROUND'. IOA FMEAS 4034 AND 4035 HAVE K1
 FAILING OPEN AT DIFFERENT TIMES WITH CRITS 2/2 AND 2/1R
 RESPECTIVELY. IOA RECOMMENDS COMBINING THE FOUR IOA FMEAs
 4034, 4035, 4037 AND 4038 INTO ONE FMEA WITH A 1/1 CRIT.

APPENDIX C
ASSESSMENT WORKSHEET

ASSESSMENT DATE: 2/12/99
 ASSESSMENT ID: RMS-4039
 NASA FMEA #: 05-6IA-2126-2

NASA DATA:
 BASELINE []
 NEW [X]

SUBSYSTEM: RMS/EPD&C
 MDAC ID: 4039
 ITEM: RELAY, K2

LEAD ANALYST: ROBINSON

ASSESSMENT:

	CRITICALITY FLIGHT HDW/FUNC	REDUNDANCY SCREENS			CIL ITEM
		A	B	C	
NASA	[2 /1R]	[P]	[F]	[P]	[X] *
IOA	[3 /3]	[]	[]	[]	[]
COMPARE	[N /N]	[N]	[N]	[N]	[N]

RECOMMENDATIONS: (If different from NASA)

[/] [] [] [] []
 (ADD/DELETE)

* CIL RETENTION RATIONALE: (If applicable)

ADEQUATE []
 INADEQUATE []

REMARKS:

UPGRADE IOA FMEA CRIT. NASA FMEA 05-6IA-2126-2 HAS BOTH K1 AND K2 FAIL WITH INADVERTENT OUTPUT. IOA FMEAS 4036 AND 4039 HAVE K1 FAILING CLOSED. RECOMMEND COMBINING BOTH RELAYS ON 4036 WITH THE FAILURE MODES IN AGREEMENT WITH NASA FMEA/CIL.

APPENDIX C
ASSESSMENT WORKSHEET

ASSESSMENT DATE: 2/12/88
 ASSESSMENT ID: RMS-4040
 NASA FMEA #: 05-6IA-2004-1

NASA DATA:
 BASELINE []
 NEW [X]

SUBSYSTEM: RMS/EPD&C
 MDAC ID: 4040
 ITEM: FUSE, F26

LEAD ANALYST: ROBINSON

ASSESSMENT:

	CRITICALITY FLIGHT HDW/FUNC	REDUNDANCY SCREENS			CIL ITEM
		A	B	C	
NASA	[1 /1]	[]	[]	[]	[X] *
IOA	[2 /1R]	[P]	[NA]	[NA]	[X]
COMPARE	[N /N]	[N]	[N]	[N]	[]

RECOMMENDATIONS: (If different from NASA)

[/] [] [] [] []
 (ADD/DELETE)

* CIL RETENTION RATIONALE: (If applicable)

ADEQUATE []
 INADEQUATE []

REMARKS:

COMBINE IOA FAIL MODES AND FMEAS AND UPGRADE CRIT. THE NASA FMEA 05-6IA-2004-1 WHILE NOT ACTUALLY SPECIFYING F26) COVERS TWO FUSES F26 AND F27. THE 'LOCATION' TYPO NEEDS CORRECTING. RECOMMEND COMBINING RMS-4040 AND 4041 IN AGREEMENT WITH NASA FMEA FAILURE AND CRIT.

APPENDIX C
ASSESSMENT WORKSHEET

ASSESSMENT DATE: 2/12/88	NASA DATA:
ASSESSMENT ID: RMS-4041	BASELINE []
NASA FMEA #: 05-6IA-2004-1	NEW [X]

SUBSYSTEM: RMS/EPD&C
MDAC ID: 4041
ITEM: FUSE, F27

LEAD ANALYST: ROBINSON

ASSESSMENT:

	CRITICALITY FLIGHT HDW/FUNC	REDUNDANCY SCREENS			CIL ITEM
		A	B	C	
NASA	[1 /1]	[]	[]	[]	[X] *
IOA	[2 /1R]	[P]	[NA]	[NA]	[X]
COMPARE	[N /N]	[N]	[N]	[N]	[]

RECOMMENDATIONS: (If different from NASA)

[/]	[]	[]	[]	[]	(ADD/DELETE)
-------------	--------	--------	--------	--------	--------------

* CIL RETENTION RATIONALE: (If applicable)

ADEQUATE	[]
INADEQUATE	[]

REMARKS:

COMBINE IOA FAIL MODES AND FMEAS, CHANGE IOA SCREEN C.
REDUNDANCY SCREEN B IS NOT APPLICABLE FOR STANDBY REDUNDANT
ITEMS. CHANGE IOA SCREEN C TO "1 - N/A - P. THE NASA FMEA 05-
6IA-2004-1 WHILE NOT ACTUALLY SPECIFYING F26) COVERS TWO FUSES
(F26 AND
COVERS TWO FUSES F26 AND F27. RECOMMEND COMBINING RMS-4040 AND
4041 IN AGREEMENT WITH NASA FMEA FAILURE AND CRIT.

APPENDIX C
ASSESSMENT WORKSHEET

ASSESSMENT DATE: 1/12/88
 ASSESSMENT ID: RMS-4042
 NASA FMEA #: 05-6IA-2176-1

NASA DATA:
 BASELINE []
 NEW [X]

SUBSYSTEM: RMS/EPD&C
 MDAC ID: 4042
 ITEM: REMOTE POWER CONTROLLER, RPC 27

LEAD ANALYST: ROBINSON

ASSESSMENT:

	CRITICALITY FLIGHT HDW/FUNC	REDUNDANCY SCREENS			CIL ITEM
		A	B	C	
NASA	[2 /1R]	[P]	[F]	[P]	[X] *
IOA	[3 /2R]	[]	[P]	[P]	[]
COMPARE	[N /N]	[N]	[N]	[]	[N]

RECOMMENDATIONS: (If different from NASA)

[/] [] [] [] []
 (ADD/DELETE)

* CIL RETENTION RATIONALE: (If applicable)

ADEQUATE []
 INADEQUATE []

REMARKS:

NASA FMEA 05-6IA-2176-1 COMPONENTS RPC 26, 27, 28 & 29 ARE ANALYZED FOR FAILURE MODES 'FAIL OPEN' AND 'SHORTS TO GROUND'. IOA RECOMMENDS COMBINING IOA FMEAS 4042, 4043, 4047 AND 4049 TO AGREE WITH NASA CRIT AND SCREENS.

APPENDIX C
ASSESSMENT WORKSHEET

ASSESSMENT DATE: 1/12/88
 ASSESSMENT ID: RMS-4044
 NASA FMEA #: 05-6IA-2178-1

NASA DATA:
 BASELINE []
 NEW [X]

SUBSYSTEM: RMS/EPD&C
 MDAC ID: 4044
 ITEM: REMOTE POWER CONTROLLER, RPC 4

LEAD ANALYST: ROBINSON

ASSESSMENT:

	CRITICALITY FLIGHT HDW/FUNC	REDUNDANCY SCREENS			CIL ITEM
		A	B	C	
NASA	[1 / 1]	[]	[]	[]	[X] *
IOA	[2 / 2]	[]	[]	[]	[X]
COMPARE	[N / N]	[]	[]	[]	[]

RECOMMENDATIONS: (If different from NASA)

[/] [] [] [] []
 (ADD/DELETE)

* CIL RETENTION RATIONALE: (If applicable)

ADEQUATE []
 INADEQUATE []

REMARKS:

NO ISSUE, IOA CONCURS WITH NASA FMEA/CIL, ADD INADVERTENTLY
 OPENS TO THE IOA FMEA AND UPGRADE IOA CRIT TO 1/1.

APPENDIX C
ASSESSMENT WORKSHEET

ASSESSMENT DATE: 1/12/88
 ASSESSMENT ID: RMS-4049X
 NASA FMEA #: 05-6IA-2028-9

NASA DATA:
 BASELINE []
 NEW [X]

SUBSYSTEM: RMS/EPD&C
 MDAC ID: 4049
 ITEM: SWITCH, S4

LEAD ANALYST: ROBINSON

ASSESSMENT:

	CRITICALITY FLIGHT HDW/FUNC	REDUNDANCY SCREENS			CIL ITEM
		A	B	C	
NASA	[1 /1]	[]	[]	[]	[X] *
IOA	[1 /1]	[]	[]	[]	[X]
COMPARE	[/]	[]	[]	[]	[]

RECOMMENDATIONS: (If different from NASA)

[/] [] [] [] []
 (ADD/DELETE)

* CIL RETENTION RATIONALE: (If applicable)

ADEQUATE []
 INADEQUATE []

REMARKS:

NO ISSUE. IOA CONCURS WITH NASA FMEA. RECOMMEND IOA GENERATE A NEW FMEA WITH THE FAILURE MODE AND CRIT OF NASA POST 51L FMEA 05-6IA-2028-9.

APPENDIX C
ASSESSMENT WORKSHEET

ASSESSMENT DATE: 2/10/88
 ASSESSMENT ID: RMS-4050X
 NASA FMEA #: 05-6IA-2076-2

NASA DATA:
 BASELINE []
 NEW [X]

SUBSYSTEM: RMS/EPD&C
 MDAC ID: 4050
 ITEM: RESISTOR, A2R2, A2R3, A3R2, A3R3

LEAD ANALYST: ROBINSON

ASSESSMENT:

	CRITICALITY FLIGHT HDW/FUNC	REDUNDANCY SCREENS			CIL ITEM
		A	B	C	
NASA	[3 / 3]	[]	[]	[]	[] *
IOA	[3 / 3]	[]	[]	[]	[]
COMPARE	[/]	[]	[]	[]	[]

RECOMMENDATIONS: (If different from NASA)

[/] [] [] [] []
 (ADD/DELETE)

* CIL RETENTION RATIONALE: (If applicable)

ADEQUATE []
 INADEQUATE []

REMARKS:

NO ISSUE. IOA CONCURS WITH NASA FMEA. RECOMMEND IOA GENERATE A NEW FMEA WITH THE FAILURE MODE AND CRIT OF NASA POST 51L FMEA 05-6IA-2076-2.

APPENDIX C
ASSESSMENT WORKSHEET

ASSESSMENT DATE: 1/12/88
 ASSESSMENT ID: RMS-4051X
 NASA FMEA #: 05-6IA-2001-2

NASA DATA:
 BASELINE []
 NEW [X]

SUBSYSTEM: RMS/EPD&C
 MDAC ID: 4051
 ITEM: CIRCUIT BREAKER, 1 PH 3A RMS, BACKUP POWER

LEAD ANALYST: ROBINSON

ASSESSMENT:

	CRITICALITY FLIGHT HDW/FUNC	REDUNDANCY SCREENS			CIL ITEM
		A	B	C	
NASA	[3 / 3]	[]	[]	[]	[] *
IOA	[3 / 3]	[]	[]	[]	[]
COMPARE	[/]	[]	[]	[]	[]

RECOMMENDATIONS: (If different from NASA)

[/] [] [] [] []
 (ADD/DELETE)

* CIL RETENTION RATIONALE: (If applicable)

ADEQUATE []
 INADEQUATE []

REMARKS:

NO ISSUE. IOA CONCURS WITH NASA FMEA. RECOMMEND IOA GENERATE A NEW FMEA WITH THE FAILURE MODE AND CRIT OF NASA POST 51L FMEA 05-6IA-2001-2.

APPENDIX C
ASSESSMENT WORKSHEET

ASSESSMENT DATE: 1/27/88
 ASSESSMENT ID: RMS-4052X
 NASA FMEA #: 05-6IA-2178-2

NASA DATA:
 BASELINE []
 NEW [X]

SUBSYSTEM: RMS/EPD&C
 MDAC ID: 4052
 ITEM: REMOTE POWER CONTROLLER, RPC 4

LEAD ANALYST: ROBINSON

ASSESSMENT:

	CRITICALITY FLIGHT HDW/FUNC	REDUNDANCY SCREENS			CIL ITEM
		A	B	C	
NASA	[3 / 3]	[]	[]	[]	[] *
IOA	[3 / 3]	[]	[]	[]	[]
COMPARE	[/]	[]	[]	[]	[]

RECOMMENDATIONS: (If different from NASA)

[/] [] [] [] []
 (ADD/DELETE)

* CIL RETENTION RATIONALE: (If applicable)

ADEQUATE []
 INADEQUATE []

REMARKS:

NO ISSUE. IOA CONCURS WITH NASA FMEA. RECOMMEND IOA GENERATE A NEW FMEA WITH THE FAILURE MODE AND CRIT OF NASA POST 51L FMEA 05-6IA-2178-2.

APPENDIX C
ASSESSMENT WORKSHEET

ASSESSMENT DATE: 2/12/88
 ASSESSMENT ID: RMS-4053X
 NASA FMEA #: 05-6IA-2176-2

NASA DATA:
 BASELINE []
 NEW [X]

SUBSYSTEM: RMS/EPD&C
 MDAC ID: 4053
 ITEM: REMOTE POWER CONTROLLER, RPC 26, 27, 28, 29

LEAD ANALYST: ROBINSON

ASSESSMENT:

	CRITICALITY FLIGHT HDW/FUNC	REDUNDANCY SCREENS			CIL ITEM
		A	B	C	
NASA	[3 /1R]	[P]	[F]	[P]	[X] *
IOA	[3 /1R]	[]	[P]	[F]	[]
COMPARE	[/]	[N]	[N]	[N]	[N]

RECOMMENDATIONS: (If different from NASA)

[/] [] [] [] []
 (ADD/DELETE)

* CIL RETENTION RATIONALE: (If applicable)

ADEQUATE []
 INADEQUATE []

REMARKS:

GENERATE AN IOA FMEA FOR THESE FAILURE MODES FOR THESE COMPONENTS.

APPENDIX C
ASSESSMENT WORKSHEET

ASSESSMENT DATE: 2/20/88
 ASSESSMENT ID: RMS-4054X
 NASA FMEA #: 05-6IA-2179-2

NASA DATA:
 BASELINE []
 NEW [X]

SUBSYSTEM: RMS/EPD&C
 MDAC ID: 4054
 ITEM: REMOTE POWER CONTROLLER, RPC 30, RPC 31

LEAD ANALYST: ROBINSON

ASSESSMENT:

	CRITICALITY FLIGHT HDW/FUNC	REDUNDANCY SCREENS			CIL ITEM
		A	B	C	
NASA	[2 /1R]	[P]	[F]	[P]	[X] *
IOA	[2 /1R]	[P]	[F]	[P]	[X]
COMPARE	[/]	[]	[]	[]	[]

RECOMMENDATIONS: (If different from NASA)

[/] [] [] [] []
 (ADD/DELETE)

* CIL RETENTION RATIONALE: (If applicable)

ADEQUATE []
 INADEQUATE []

REMARKS:

NO ISSUE. IOA CONCURS WITH NASA FMEA. RECOMMEND IOA GENERATE A NEW FMEA WITH THE FAILURE MODE AND CRIT OF NASA POST 51L FMEA 05-6IA-2179-2.

APPENDIX C
ASSESSMENT WORKSHEET

ASSESSMENT DATE: 3/06/87
 ASSESSMENT ID: RMS-4101
 NASA FMEA #: EPD&C 05-6-2658-1

NASA DATA:
 BASELINE [X]
 NEW []

SUBSYSTEM: RMS/EPD&C
 MDAC ID: 4101
 ITEM: SWITCH, S1

LEAD ANALYST: ROBINSON

ASSESSMENT:

	CRITICALITY FLIGHT HDW/FUNC	REDUNDANCY SCREENS			CIL ITEM
		A	B	C	
NASA	[/]	[]	[]	[]	[] *
IOA	[2 /1R]	[P]	[P]	[P]	[X]
COMPARE	[N /N]	[N]	[N]	[N]	[N]

RECOMMENDATIONS: (If different from NASA)

[/] [] [] [] []
 (ADD/DELETE)

* CIL RETENTION RATIONALE: (If applicable)

ADEQUATE []
 INADEQUATE []

REMARKS:

DISREGARD THIS IOA FMEA AND REFER TO IOA FMEA EPD&C-5827.
 THIS COMPONENT IS PART OF THE EPD&C PAYLOAD BAY MECHANICAL POWER
 SYSTEM AND SHOULD BE ANALYZED WITH REGARDS TO THE TOTAL EFFECTS
 OF THE FAILURE AND NOT LIMITED TO ITS EFFECTS ON RMS.

APPENDIX C
ASSESSMENT WORKSHEET

ASSESSMENT DATE: 3/06/87
 ASSESSMENT ID: RMS-4102
 NASA FMEA #: EPD&C 05-6-2658-2

NASA DATA:
 BASELINE [X]
 NEW []

SUBSYSTEM: RMS/EPD&C
 MDAC ID: 4102
 ITEM: SWITCH, S1

LEAD ANALYST: ROBINSON

ASSESSMENT:

	CRITICALITY FLIGHT HDW/FUNC	REDUNDANCY SCREENS			CIL ITEM
		A	B	C	
NASA	[/]	[]	[]	[]	[] *
IOA	[3 / 3]	[]	[]	[]	[]
COMPARE	[N / N]	[]	[]	[]	[]

RECOMMENDATIONS: (If different from NASA)

[/] [] [] [] []
 (ADD/DELETE)

* CIL RETENTION RATIONALE: (If applicable)

ADEQUATE []
 INADEQUATE []

REMARKS:

DISREGARD THIS IOA FMEA AND REFER TO IOA FMEA EPD&C-5828
 THIS COMPONENT IS PART OF THE EPD&C PAYLOAD BAY MECHANICAL POWER
 SYSTEM AND SHOULD BE ANALYZED WITH REGARDS TO THE TOTAL EFFECTS
 OF THE FAILURE AND NOT LIMITED TO ITS EFFECTS ON RMS.

APPENDIX C
ASSESSMENT WORKSHEET

ASSESSMENT DATE: 3/06/87
 ASSESSMENT ID: RMS-4103
 NASA FMEA #: EPD&C 05-6-2658-1

NASA DATA:
 BASELINE [X]
 NEW []

SUBSYSTEM: RMS/EPD&C
 MDAC ID: 4103
 ITEM: SWITCH, S2

LEAD ANALYST: ROBINSON

ASSESSMENT:

	CRITICALITY FLIGHT HDW/FUNC	REDUNDANCY SCREENS			CIL ITEM
		A	B	C	
NASA	[/]	[]	[]	[]	[] *
IOA	[2 /1R]	[P]	[P]	[P]	[X]
COMPARE	[N /N]	[N]	[N]	[N]	[N]

RECOMMENDATIONS: (If different from NASA)

[/] [] [] [] []
 (ADD/DELETE)

* CIL RETENTION RATIONALE: (If applicable)

ADEQUATE []
 INADEQUATE []

REMARKS:

DISREGARD THIS IOA FMEA AND REFER TO IOA FMEA EPD&C-5830.
 THIS COMPONENT IS PART OF THE EPD&C PAYLOAD BAY MECHANICAL POWER
 SYSTEM AND SHOULD BE ANALYZED WITH REGARDS TO THE TOTAL EFFECTS
 OF THE FAILURE AND NOT LIMITED TO ITS EFFECTS ON RMS.

APPENDIX C
ASSESSMENT WORKSHEET

ASSESSMENT DATE: 3/06/87
 ASSESSMENT ID: RMS-4104
 NASA FMEA #: EPD&C 05-6-2658-2

NASA DATA:
 BASELINE [X]
 NEW []

SUBSYSTEM: RMS/EPD&C
 MDAC ID: 4104
 ITEM: SWITCH, S2

LEAD ANALYST: ROBINSON

ASSESSMENT:

	CRITICALITY FLIGHT HDW/FUNC	REDUNDANCY SCREENS			CIL ITEM
		A	B	C	
NASA	[/]	[]	[]	[]	[] *
IOA	[3 / 3]	[]	[]	[]	[]
COMPARE	[N / N]	[]	[]	[]	[]

RECOMMENDATIONS: (If different from NASA)

[/] [] [] [] []
 (ADD/DELETE)

* CIL RETENTION RATIONALE: (If applicable)

ADEQUATE []
 INADEQUATE []

REMARKS:

DISREGARD THIS IOA FMEA AND REFER TO IOA FMEA EPD&C-5829.
 THIS COMPONENT IS PART OF THE EPD&C PAYLOAD BAY MECHANICAL POWER
 SYSTEM AND SHOULD BE ANALYZED WITH REGARDS TO THE TOTAL EFFECTS
 OF THE FAILURE AND NOT LIMITED TO ITS EFFECTS ON RMS.

APPENDIX C
ASSESSMENT WORKSHEET

ASSESSMENT DATE: 1/15/88
 ASSESSMENT ID: RMS-4105
 NASA FMEA #: 05-6IB-MPM-2A

NASA DATA:
 BASELINE []
 NEW [X]

SUBSYSTEM: RMS/EPD&C
 MDAC ID: 4105
 ITEM: SWITCH, S5

LEAD ANALYST: ROBINSON

ASSESSMENT:

	CRITICALITY FLIGHT HDW/FUNC	REDUNDANCY SCREENS			CIL ITEM
		A	B	C	
NASA	[2 /1R]	[P]	[P]	[P]	[X] *
IOA	[2 /2]	[]	[]	[]	[X]
COMPARE	[/N]	[N]	[N]	[N]	[]

RECOMMENDATIONS: (If different from NASA)

[/] [] [] [] []
 (ADD/DELETE)

* CIL RETENTION RATIONALE: (If applicable)

ADEQUATE []
 INADEQUATE []

REMARKS:

UPGRADE IOA CRIT AND SCREENS, COMBINE COMPONENTS ON IOA FMEAs 4105 AND 4107. ADD THIS SWITCH TO NASA FMEA.
 IOA RECOMMENDS COMBINING THIS FMEA WITH RMS-4107 AND ADDING THIS SWITCH. S5, TO THE NASA FMEA 05-6IB-MPM-2A. THIS SWITCH IS PART OF THE PORT RMS. THE POST 51L NASA FMEAs DO NOT INCLUDE THE PORT RMS BUT THE BASELINE NASA FMEAs DID INCLUDE THE PORT RMS. REFER TO IOA FMEA 4107.

APPENDIX C
ASSESSMENT WORKSHEET

ASSESSMENT DATE: 1/15/88
 ASSESSMENT ID: RMS-4106
 NASA FMEA #: 05-6IB-MPM-2B

NASA DATA:
 BASELINE []
 NEW [X]

SUBSYSTEM: RMS/EPD&C
 MDAC ID: 4106
 ITEM: SWITCH, S5

LEAD ANALYST: ROBINSON

ASSESSMENT:

	CRITICALITY FLIGHT HDW/FUNC	REDUNDANCY SCREENS			CIL ITEM
		A	B	C	
NASA	[1 / 1]	[P]	[P]	[P]	[X] *
IOA	[1 / 1]	[]	[]	[]	[X]
COMPARE	[/]	[N]	[N]	[N]	[]

RECOMMENDATIONS: (If different from NASA)

[/] [] [] [] []
 (ADD/DELETE)

* CIL RETENTION RATIONALE: (If applicable)

ADEQUATE []
 INADEQUATE []

REMARKS:

REFER TO REMARKS ON IOA RMS-4108. COMBINE IOA FMEAs AND ADD THIS SWITCH TO NASA FMEA.
 IOA RECOMMENDS COMBINING THIS FMEA WITH RMS-4108 AND ADDING THIS SWITCH. S5, TO THE NASA FMEA 05-6IB-MPM-2B. THIS SWITCH IS PART OF THE PORT RMS. THE POST 51L NASA FMEAs DO NOT INCLUDE THE PORT RMS BUT THE BASELINE NASA FMEAs DID INCLUDE THE PORT RMS.

APPENDIX C
ASSESSMENT WORKSHEET

ASSESSMENT DATE: 1/15/88
 ASSESSMENT ID: RMS-4107
 NASA FMEA #: 05-61B-MPM-2A

NASA DATA:
 BASELINE []
 NEW [X]

SUBSYSTEM: RMS/EPD&C
 MDAC ID: 4107
 ITEM: SWITCH, S2

LEAD ANALYST: ROBINSON

ASSESSMENT:

	CRITICALITY FLIGHT HDW/FUNC	REDUNDANCY SCREENS			CIL ITEM
		A	B	C	
NASA	[2 /1R]	[P]	[P]	[P]	[X] *
IOA	[2 /2]	[]	[]	[]	[X]
COMPARE	[/N]	[N]	[N]	[N]	[]

RECOMMENDATIONS: (If different from NASA)

[/] [] [] [] []
 (ADD/DELETE)

* CIL RETENTION RATIONALE: (If applicable)

ADEQUATE []
 INADEQUATE []

REMARKS:

IOA CONCURS WITH NASA POST F1L FMEA. UPGRADE IOA CRIT TO 2/1R AND CHANGE REDUNDANCY SCREENS ACCORDINGLY.
 IOA RECOMMENDS NASA ADDING S5 (PORT) TO POST 51L FMEA 05-61B-MPM-2A. IOA RECOMMENDS IOA COMBINE COMPONENTS ON IOA FMEAs 4105 AND 4107 FOR THIS FAILURE MODE SINCE THE EFFECT WOULD BE THE SAME FOR EITHER SWITCH FAILURE.
 LOSS OF OPERATION OF THE STOW/DEPLOY ACTUATOR COULD CAUSE LOSS OF MISSION AND POSSIBLY REQUIRE JETTISON OF THE REMOTE MANIPULATOR ARM IF IT CANNOT BE SAFELY STOWED AND POSSIBLE LOSS OF CREW/VEHICLE IF IT CANNOT BE JETTISONED.
 REFER TO IOA FMEA 4105.

APPENDIX C
ASSESSMENT WORKSHEET

ASSESSMENT DATE: 1/28/88
 ASSESSMENT ID: RMS-4108A
 NASA FMEA #: 05-6IB-MPM-2B

NASA DATA:
 BASELINE []
 NEW [X]

SUBSYSTEM: RMS/EPD&C
 MDAC ID: 4108
 ITEM: SWITCH, S2

LEAD ANALYST: ROBINSON

ASSESSMENT:

	CRITICALITY FLIGHT HDW/FUNC	REDUNDANCY SCREENS			CIL ITEM
		A	B	C	
NASA	[1 / 1]	[P]	[P]	[P]	[X] *
IOA	[1 / 1]	[]	[]	[]	[X]
COMPARE	[/]	[N]	[N]	[N]	[]

RECOMMENDATIONS: (If different from NASA)

[/] [] [] [] []
 (ADD/DELETE)

* CIL RETENTION RATIONALE: (If applicable)

ADEQUATE []
 INADEQUATE []

REMARKS:

THE FAILURE MODE FOR SWITCH 36V73A8A2S2 IN NASA FMEA 05-6IB-MPM-2B IS "FAILS CLOSED (ON)" WITH A 1/1 CRIT ASSIGNED. THE FAILURE MODE FOR THE SAME SWITCH IN NASA FMEA 05-6IB-MPM-2D IS "PREMATURE CLOSE" WITH CRIT 1/1 ASSIGNED. THE FAILURE MODE FOR THE SAME SWITCH IN NASA FMEA 05-6IB-MPM-2E IS "CONTACT TO CONTACT SHORT" WITH A CRIT 1/1 ASSIGNED. IOA CONCURS THAT THESE ARE ALL CREDIBLE FAILURES AND RECOMMENDS THAT THEY BE CONSIDERED FOR THE CRITICAL ITEMS LIST. SINCE THE FAILURE MODES ARE ALL FOR THE CREDIBLE FAILURES AND RECOMMENDS THAT THEY BE INCLUDED ON THE CRITICAL ITEMS LIST. SINCE ALL THE FAILURES ARE FOR THE SAME SWITCH AND THE CRITICALITIES ASSIGNED ARE ALL 1/1, IOA RECOMMENDS THAT ALL THESE FOUR FAILURE MODES FOR THIS SWITCH AND FOR ITS CORRESPONDING SWITCH ON THE PORT ARM BE COMBINED INTO ONE FMEA. IOA RECOMMENDS COMBINING RMS-4106 AND 4108 AND MODIFYING THE FMEA TO INCLUDE THE FAILURE MODES OF THE FOUR NASA FMEAs.

APPENDIX C
ASSESSMENT WORKSHEET

ASSESSMENT DATE: 1/28/88
 ASSESSMENT ID: RMS-4108
 NASA FMEA #: 05-6IB-MPM-2B, D, E, G

NASA DATA:
 BASELINE []
 NEW [X]

SUBSYSTEM: RMS/EPD&C
 MDAC ID: 4108
 ITEM: SWITCH, S2

LEAD ANALYST: ROBINSON

ASSESSMENT:

	CRITICALITY FLIGHT HDW/FUNC	REDUNDANCY SCREENS			CIL ITEM
		A	B	C	
NASA	[1 /1]	[P]	[P]	[P]	[X] *
IOA	[1 /1]	[]	[]	[]	[X]
COMPARE	[/]	[N]	[N]	[N]	[]

RECOMMENDATIONS: (If different from NASA)

[/] [] [] [] []
 (ADD/DELETE)

* CIL RETENTION RATIONALE: (If applicable)

ADEQUATE []
 INADEQUATE []

REMARKS:

THE FAILURE MODE FOR SWITCH 36V73A8A2S2 IN NASA FMEA 05-6IB-MPM-2B IS "FAILS CLOSED (ON)" WITH A 1/1 CRIT ASSIGNED. THE FAILURE MODE FOR THE SAME SWITCH IN NASA FMEA 05-6IB-MPM-2D IS "PREMATURE CLOSE" WITH CRIT 1/1 ASSIGNED. THE FAILURE MODE FOR THE SAME SWITCH IN NASA FMEA 05-6IB-MPM-2E IS "CONTACT TO CONTACT SHORT" WITH A CRIT 1/1 ASSIGNED. THE FAILURE MODE FOR SWITCH S2 IN NASA FMEA 05-61B-MPM-2G IS "SHORTS POLE TO POLE" WITH A CRIT 1/1 ASSIGNED. IOA CONCURS THAT ALL THE FAILURE MODES ARE CREDIBLE FAILURES AND RECOMMENDS THAT THEY BE INCLUDED ON THE CRITICAL ITEMS LIST. SINCE ALL THE FAILURES ARE FOR THE SAME SWITCH AND THE CRITICALITIES ASSIGNED ARE ALL 1/1, IOA RECOMMENDS THAT ALL THESE FOUR FAILURE MODES FOR THIS SWITCH AND FOR ITS CORRESPONDING SWITCH ON THE PORT ARM BE COMBINED INTO ONE FMEA. IOA RECOMMENDS COMBINING RMS-4106 AND 4108 AND MODIFYING THE FMEA TO INCLUDE THE FAILURE MODES OF THE FOUR NASA FMEAs.

APPENDIX C
ASSESSMENT WORKSHEET

ASSESSMENT DATE: 1/28/88
 ASSESSMENT ID: RMS-4108B
 NASA FMEA #: 05-6IB-MPM-2D

NASA DATA:
 BASELINE []
 NEW [X]

SUBSYSTEM: RMS/EPD&C
 MDAC ID: 4108
 ITEM: SWITCH, S2

LEAD ANALYST: ROBINSON

ASSESSMENT:

	CRITICALITY FLIGHT HDW/FUNC	REDUNDANCY SCREENS			CIL ITEM
		A	B	C	
NASA	[1 / 1]	[P]	[P]	[P]	[X] *
IOA	[1 / 1]	[]	[]	[]	[X]
COMPARE	[/]	[N]	[N]	[N]	[]

RECOMMENDATIONS: (If different from NASA)

[/] [] [] [] []
 (ADD/DELETE)

* CIL RETENTION RATIONALE: (If applicable)

ADEQUATE []
 INADEQUATE []

REMARKS:

THE FAILURE MODE FOR SWITCH 36V73A8A2S2 IN NASA FMEA 05-6IB-MPM-2B IS "FAILS CLOSED (ON)" WITH A 1/1 CRIT ASSIGNED. THE FAILURE MODE FOR THE SAME SWITCH IN NASA FMEA 05-6IB-MPM-2D IS "PREMATURE CLOSE" WITH CRIT 1/1 ASSIGNED. THE FAILURE MODE FOR THE SAME SWITCH IN NASA FMEA 05-6IB-MPM-2E IS "CONTACT TO CONTACT SHORT" WITH A CRIT 1/1 ASSIGNED. IOA CONCURS THAT THESE ARE ALL CREDIBLE FAILURES AND RECOMMENDS THAT THEY BE CONSIDERED FOR THE CRITICAL ITEMS LIST. SINCE THE FAILURE MODES ARE ALL FOR THE CREDIBLE FAILURES AND RECOMMENDS THAT THEY BE INCLUDED ON THE CRITICAL ITEMS LIST. SINCE ALL THE FAILURES ARE FOR THE SAME SWITCH AND THE CRITICALITIES ASSIGNED ARE ALL 1/1, IOA RECOMMENDS THAT ALL THESE FOUR FAILURE MODES FOR THIS SWITCH AND FOR ITS CORRESPONDING SWITCH ON THE PORT ARM BE COMBINED INTO ONE FMEA. IOA RECOMMENDS COMBINING RMS-4106 AND 4108 AND MODIFYING THE FMEA TO INCLUDE THE FAILURE MODES OF THE FOUR NASA FMEAs.

APPENDIX C
ASSESSMENT WORKSHEET

ASSESSMENT DATE: 1/28/88
 ASSESSMENT ID: RMS-4108C
 NASA FMEA #: 05-6IB-MPM-2E

NASA DATA:
 BASELINE []
 NEW [X]

SUBSYSTEM: RMS/EPD&C
 MDAC ID: 4108
 ITEM: SWITCH, S2

LEAD ANALYST: ROBINSON

ASSESSMENT:

	CRITICALITY FLIGHT HDW/FUNC	A	B	C	CIL ITEM	
NASA	[1 / 1]	[P]	[P]	[P]	[X]	*
IOA	[1 / 1]	[]	[]	[]	[X]	
COMPARE	[/]	[N]	[N]	[N]	[]	

RECOMMENDATIONS: (If different from NASA)

[/] [] [] [] []
 (ADD/DELETE)

* CIL RETENTION RATIONALE: (If applicable)

ADEQUATE []
 INADEQUATE []

REMARKS:

THE FAILURE MODE FOR SWITCH 36V73A8A2S2 IN NASA FMEA 05-6IB-MPM-2B IS "FAILS CLOSED (ON)" WITH A 1/1 CRIT ASSIGNED. THE FAILURE MODE FOR THE SAME SWITCH IN NASA FMEA 05-6IB-MPM-2D IS "PREMATURE CLOSE" WITH CRIT 1/1 ASSIGNED. THE FAILURE MODE FOR THE SAME SWITCH IN NASA FMEA 05-6IB-MPM-2E IS "CONTACT TO CONTACT SHORT" WITH A CRIT 1/1 ASSIGNED. IOA CONCURS THAT THESE ARE ALL CREDIBLE FAILURES AND RECOMMENDS THAT THEY BE CONSIDERED FOR THE CRITICAL ITEMS LIST. SINCE THE FAILURE MODES ARE ALL FOR THE CREDIBLE FAILURES AND RECOMMENDS THAT THEY BE INCLUDED ON THE CRITICAL ITEMS LIST. SINCE ALL THE FAILURES ARE FOR THE SAME SWITCH AND THE CRITICALITIES ASSIGNED ARE ALL 1/1, IOA RECOMMENDS THAT ALL THESE FOUR FAILURE MODES FOR THIS SWITCH AND FOR ITS CORRESPONDING SWITCH ON THE PORT ARM BE COMBINED INTO ONE FMEA. IOA RECOMMENDS COMBINING RMS-4106 AND 4108 AND MODIFYING THE FMEA TO INCLUDE THE FAILURE MODES OF THE FOUR NASA FMEAs.

APPENDIX C
ASSESSMENT WORKSHEET

ASSESSMENT DATE: 1/28/88
 ASSESSMENT ID: RMS-4108D
 NASA FMEA #: 05-6IB-MPM-2G

NASA DATA:
 BASELINE []
 NEW [X]

SUBSYSTEM: RMS/EPD&C
 MDAC ID: 4108
 ITEM: SWITCH, S2

LEAD ANALYST: ROBINSON

ASSESSMENT:

	CRITICALITY FLIGHT HDW/FUNC	REDUNDANCY SCREENS			CIL ITEM
		A	B	C	
NASA	[1 / 1]	[P]	[P]	[P]	[X] *
IOA	[1 / 1]	[]	[]	[]	[X]
COMPARE	[/]	[N]	[N]	[N]	[]

RECOMMENDATIONS: (If different from NASA)

[/] [] [] [] [] (ADD/DELETE)

* CIL RETENTION RATIONALE: (If applicable)

ADEQUATE []
 INADEQUATE []

REMARKS:

THE FAILURE MODE FOR SWITCH 36V73A8A2S2 IN NASA FMEA 05-6IB-MPM-2B IS "FAILS CLOSED (ON)" WITH A 1/1 CRIT ASSIGNED. THE FAILURE MODE FOR THE SAME SWITCH IN NASA FMEA 05-6IB-MPM-2D IS "PREMATURE CLOSE" WITH CRIT 1/1 ASSIGNED. THE FAILURE MODE FOR THE SAME SWITCH IN NASA FMEA 05-6IB-MPM-2E IS "CONTACT TO CONTACT SHORT" WITH A CRIT 1/1 ASSIGNED. IOA CONCURS THAT THESE ARE ALL CREDIBLE FAILURES AND RECOMMENDS THAT THEY BE CONSIDERED FOR THE CRITICAL ITEMS LIST. SINCE THE FAILURE MODES ARE ALL FOR THE CREDIBLE FAILURES AND RECOMMENDS THAT THEY BE INCLUDED ON THE CRITICAL ITEMS LIST. SINCE ALL THE FAILURES ARE FOR THE SAME SWITCH AND THE CRITICALITIES ASSIGNED ARE ALL 1/1, IOA RECOMMENDS THAT ALL THESE FOUR FAILURE MODES FOR THIS SWITCH AND FOR ITS CORRESPONDING SWITCH ON THE PORT ARM BE COMBINED INTO ONE FMEA. IOA RECOMMENDS COMBINING RMS-4106 AND 4108 AND MODIFYING THE FMEA TO INCLUDE THE FAILURE MODES OF THE FOUR NASA FMEAs.

APPENDIX C
ASSESSMENT WORKSHEET

ASSESSMENT DATE: 1/15/88
 ASSESSMENT ID: RMS-4109
 NASA FMEA #: 05-6IB-MPM-1

NASA DATA:
 BASELINE []
 NEW [X]

SUBSYSTEM: RMS/EPD&C
 MDAC ID: 4109
 ITEM: FUSE, F6

LEAD ANALYST: ROBINSON

ASSESSMENT:

	CRITICALITY FLIGHT HDW/FUNC	REDUNDANCY SCREENS			CIL ITEM
		A	B	C	
NASA	[3 /1R]	[P]	[P]	[P]	[] *
IOA	[3 /2R]	[]	[P]	[P]	[]
COMPARE	[/N]	[N]	[]	[]	[]

RECOMMENDATIONS: (If different from NASA)

[/] [] [] [] []
 (ADD/DELETE)

* CIL RETENTION RATIONALE: (If applicable)

ADEQUATE []
 INADEQUATE []

REMARKS:

IOA CONCURS WITH NASA POST 51L FMEA. RECOMMEND UPGRADING IOA CRIT TO 3/1R. RECOMMEND COMBINING THE COMPONENTS ON IOA FMEAs 4109, 4110, 4111, AND 4112 FOR ASSESSMENT PURPOSES.

APPENDIX C
ASSESSMENT WORKSHEET

ASSESSMENT DATE: 1/15/88
 ASSESSMENT ID: RMS-4110
 NASA FMEA #: 05-6IB-MPM-1

NASA DATA:
 BASELINE []
 NEW [X]

SUBSYSTEM: RMS/EPD&C
 MDAC ID: 4110
 ITEM: FUSE, F5

LEAD ANALYST: ROBINSON

ASSESSMENT:

	CRITICALITY FLIGHT HDW/FUNC	REDUNDANCY SCREENS			CIL ITEM
		A	B	C	
NASA	[3 /1R]	[P]	[P]	[P]	[] *
IOA	[3 /2R]	[]	[P]	[P]	[]
COMPARE	[/N]	[N]	[]	[]	[]

RECOMMENDATIONS: (If different from NASA)

[/] [] [] [] []
 (ADD/DELETE)

* CIL RETENTION RATIONALE: (If applicable)

ADEQUATE []
 INADEQUATE []

REMARKS:

IOA CONCURS WITH NASA POST 51L FMEA. RECOMMEND UPGRADING IOA CRIT TO 3/1R. RECOMMEND COMBINING THE IOA FMEAs 4109, 4110, 4111, AND 4112 FOR ASSESSMENT PURPOSES.

APPENDIX C
ASSESSMENT WORKSHEET

ASSESSMENT DATE: 1/15/88
 ASSESSMENT ID: RMS-4111
 NASA FMEA #: 05-6IB-MPM-1

NASA DATA:
 BASELINE []
 NEW [X]

SUBSYSTEM: RMS/EPD&C
 MDAC ID: 4111
 ITEM: FUSE, F11

LEAD ANALYST: ROBINSON

ASSESSMENT:

	CRITICALITY FLIGHT HDW/FUNC	REDUNDANCY SCREENS			CIL ITEM
		A	B	C	
NASA	[3 /1R]	[P]	[P]	[P]	[] *
IOA	[3 /2R]	[]	[P]	[P]	[]
COMPARE	[/N]	[N]	[]	[]	[]

RECOMMENDATIONS: (If different from NASA)

[/] [] [] [] []
 (ADD/DELETE)

* CIL RETENTION RATIONALE: (If applicable)

ADEQUATE []
 INADEQUATE []

REMARKS:

IOA CONCURS WITH NASA POST 51L FMEA. RECOMMEND UPGRADING IOA CRIT TO 3/1R. RECOMMEND COMBINING THE IOA FMEAs 4109, 4110, 4111, AND 4112 FOR ASSESSMENT PURPOSES.

APPENDIX C
ASSESSMENT WORKSHEET

ASSESSMENT DATE: 1/15/88
 ASSESSMENT ID: RMS-4112
 NASA FMEA #: 05-6IB-MPM-1

NASA DATA:
 BASELINE []
 NEW [X]

SUBSYSTEM: RMS/EPD&C
 MDAC ID: 4112
 ITEM: FUSE, F10

LEAD ANALYST: ROBINSON

ASSESSMENT:

	CRITICALITY FLIGHT HDW/FUNC	REDUNDANCY SCREENS			CIL ITEM
		A	B	C	
NASA	[3 /1R]	[P]	[P]	[P]	[] *
IOA	[3 /2R]	[]	[P]	[P]	[]
COMPARE	[/N]	[N]	[]	[]	[]

RECOMMENDATIONS: (If different from NASA)

[/] [] [] [] []
 (ADD/DELETE)

* CIL RETENTION RATIONALE: (If applicable)

ADEQUATE []
 INADEQUATE []

REMARKS:

IOA CONCURS WITH NASA POST 51L FMEA. RECOMMEND UPGRADING IOA CRIT TO 3/1R. RECOMMEND COMBINING THE IOA FMEAs 4109, 4110, 4111, AND 4112 FOR ASSESSMENT PURPOSES.

APPENDIX C
ASSESSMENT WORKSHEET

ASSESSMENT DATE: 1/15/88
 ASSESSMENT ID: RMS-4113
 NASA FMEA #: 05-6IB-MPM-4

NASA DATA:
 BASELINE []
 NEW [X]

SUBSYSTEM: RMS/EPD&C
 MDAC ID: 4113
 ITEM: HYBRID RELAY, K72

LEAD ANALYST: ROBINSON

ASSESSMENT:

	CRITICALITY FLIGHT HDW/FUNC	REDUNDANCY SCREENS			CIL ITEM
		A	B	C	
NASA	[3 /1R]	[P]	[P]	[P]	[] *
IOA	[3 /2R]	[]	[P]	[P]	[]
COMPARE	[/N]	[N]	[]	[]	[]

RECOMMENDATIONS: (If different from NASA)

[/] [] [] [] []
 (ADD/DELETE)

* CIL RETENTION RATIONALE: (If applicable)

ADEQUATE []
 INADEQUATE []

REMARKS:

UPGRADE IOA CRIT TO 3/1R AND COMBINE IOA FMEAs TO INCLUDE LIKE CORRESPONDING COMPONENTS FOR PORT AND STARBOARD SYSTEMS. IOA CONCURS WITH NASA POST 51L CRIT 3/1R. THE NASA FMEAs DO NOT SPECIFY REFERENCE DESIGNATORS AND DID NOT DUPLICATE FMEAs FOR BOTH THE PORT AND STARBOARD SYSTEMS. THEREFORE, SINCE IOA DOES, IOA HAS TWO FMEAs THAT CORRESPOND TO ONE NASA FMEA. FOR ASSESSMENT PURPOSES THE BOTH PORT AND STARBOARD IOA FMEAs WERE COMPARED TO THE EQUIVALENT NASA FMEA SINCE THE EFFECT WOULD BE THE SAME WHETHER IT BE A PORT OR A STARBOARD FAILURE.

APPENDIX C
ASSESSMENT WORKSHEET

ASSESSMENT DATE: 1/29/88
ASSESSMENT ID: RMS-4114
NASA FMEA #: 05-6IB-MPM-5

NASA DATA:
BASELINE []
NEW [X]

SUBSYSTEM: RMS/EPD&C
MDAC ID: 4114
ITEM: HYBRID RELAY, K72

LEAD ANALYST: ROBINSON

ASSESSMENT:

	CRITICALITY FLIGHT HDW/FUNC	REDUNDANCY SCREENS			CIL ITEM
		A	B	C	
NASA	[1 / 1]	[N]	[N]	[N]	[X] *
IOA	[1 / 1]	[]	[]	[]	[X]
COMPARE	[/]	[N]	[N]	[N]	[]

RECOMMENDATIONS: (If different from NASA)

[/] [] [] [] []
(ADD/DELETE)

* CIL RETENTION RATIONALE: (If applicable)

ADEQUATE []
INADEQUATE []

REMARKS:

UNTIMELY OPERATION OF A DEPLOY ACTUATOR MOTOR COULD CAUSE PHYSICAL DAMAGE TO THE RMS/PAYLOADS/ORBITER. LOSS OF MISSION AND POSSIBLY LOSS OF CREW/VEHICLE COULD RESULT. THE NASA POST 51L FMEAs DO NOT SPECIFY REFERENCE DESIGNATORS AND DO NOT DUPLICATE FMEAs FOR PORT AND STARBOARD SYSTEMS. THEREFORE, SINCE IOA DOES, IOA HAS TWO FMEAs THAT CORRESPOND TO ONE NASA POST 51L FMEA. FOR ASSESSMENT PURPOSES THE BOTH (2) IOA FMEAs WERE COMPARED TO THE SAME ONE (1) NASA FMEA.

IOA RECOMMENDS COMBINING THE COMPONENTS ON THE FOLLOWING IOA FMEAs INTO ONE (1) FMEA FOR ASSESSMENT PURPOSES: 4114, 4116, 4118, 4120, 4122, 4124, 4126 AND 4128.

APPENDIX C
ASSESSMENT WORKSHEET

ASSESSMENT DATE: 1/15/88
 ASSESSMENT ID: RMS-4115
 NASA FMEA #: 05-6IB-MPM-4

NASA DATA:
 BASELINE []
 NEW [X]

SUBSYSTEM: RMS/EPD&C
 MDAC ID: 4115
 ITEM: HYBRID RELAY, K49

LEAD ANALYST: ROBINSON

ASSESSMENT:

	CRITICALITY FLIGHT HDW/FUNC	REDUNDANCY SCREENS			CIL ITEM
		A	B	C	
NASA	[3 /1R]	[P]	[P]	[P]	[] *
IOA	[3 /2R]	[]	[P]	[P]	[]
COMPARE	[/N]	[N]	[]	[]	[]

RECOMMENDATIONS: (If different from NASA)

[/] [] [] [] []
 (ADD/DELETE)

* CIL RETENTION RATIONALE: (If applicable)

ADEQUATE []
 INADEQUATE []

REMARKS:

UPGRADE IOA CRIT TO 3/1R AND COMBINE IOA FMEAs TO INCLUDE LIKE CORRESPONDING COMPONENTS FOR PORT AND STARBOARD SYSTEMS. IOA CONCURS WITH NASA POST 51L CRIT 3/1R. THE NASA FMEAs DO NOT SPECIFY REFERENCE DESIGNATORS AND DID NOT DUPLICATE FMEAs FOR BOTH THE PORT AND STARBOARD SYSTEMS. THEREFORE, SINCE IOA DOES, IOA HAS TWO FMEAs THAT CORRESPOND TO ONE NASA FMEA. FOR ASSESSMENT PURPOSES THE BOTH PORT AND STARBOARD IOA FMEAs WERE COMPARED TO THE EQUIVALENT NASA FMEA SINCE THE EFFECT WOULD BE THE SAME WHETHER IT BE A PORT OR A STARBOARD FAILURE.

APPENDIX C
ASSESSMENT WORKSHEET

ASSESSMENT DATE: 1/29/88
 ASSESSMENT ID: RMS-4116
 NASA FMEA #: 05-6IB-MPM-5

NASA DATA:
 BASELINE []
 NEW [X]

SUBSYSTEM: RMS/EPD&C
 MDAC ID: 4116
 ITEM: HYBRID RELAY, K49

LEAD ANALYST: ROBINSON

ASSESSMENT:

	CRITICALITY FLIGHT HDW/FUNC	REDUNDANCY SCREENS			CIL ITEM
		A	B	C	
NASA	[1 / 1]	[N]	[N]	[N]	[X] *
IOA	[1 / 1]	[]	[]	[]	[X]
COMPARE	[/]	[N]	[N]	[N]	[]

RECOMMENDATIONS: (If different from NASA)

[/] [] [] [] []
 (ADD/DELETE)

* CIL RETENTION RATIONALE: (If applicable)

ADEQUATE []
 INADEQUATE []

REMARKS:

UNTIMELY OPERATION OF A DEPLOY ACTUATOR MOTOR COULD CAUSE PHYSICAL DAMAGE TO THE RMS/PAYLOADS/ORBITER. LOSS OF MISSION AND POSSIBLY LOSS OF CREW/VEHICLE COULD RESULT. THE NASA POST 51L FMEAs DO NOT SPECIFY REFERENCE DESIGNATORS AND DO NOT DUPLICATE FMEAs FOR PORT AND STARBOARD SYSTEMS. THEREFORE, SINCE IOA DOES, IOA HAS TWO FMEAs THAT CORRESPOND TO ONE NASA POST 51L FMEA. FOR ASSESSMENT PURPOSES THE BOTH IOA FMEAs WERE COMPARED TO THE SAME ONE NASA FMEA.

IOA RECOMMENDS COMBINING THE COMPONENTS ON THE FOLLOWING IOA FMEAs INTO ONE (1) FMEA FOR ASSESSMENT PURPOSES: 4114, 4116, 4118, 4120, 4122, 4124, 4126 AND 4128.

APPENDIX C
ASSESSMENT WORKSHEET

ASSESSMENT DATE: 1/15/88	NASA DATA:
ASSESSMENT ID: RMS-4117	BASELINE []
NASA FMEA #: 05-6IB-MPM-4	NEW [X]
SUBSYSTEM: RMS/EPD&C	
MDAC ID: 4117	
ITEM: HYBRID RELAY, K60	
LEAD ANALYST: ROBINSON	

ASSESSMENT:

	CRITICALITY	REDUNDANCY SCREENS			CIL ITEM
	FLIGHT HDW/FUNC	A	B	C	
NASA	[3 /1R]	[P]	[P]	[P]	[] *
IOA	[3 /2R]	[]	[P]	[P]	[]
COMPARE	[/N]	[N]	[]	[]	[]

RECOMMENDATIONS: (If different from NASA)

[/] [] [] [] []
(ADD/DELETE)

* CIL RETENTION RATIONALE: (If applicable)

ADEQUATE []
INADEQUATE []

REMARKS:

UPGRADE IOA CRIT TO 3/1R AND COMBINE IOA FMEAs TO INCLUDE LIKE CORRESPONDING COMPONENTS FOR PORT AND STARBOARD SYSTEMS. IOA CONCURS WITH NASA POST 51L CRIT 3/1R. THE NASA FMEAs DO NOT SPECIFY REFERENCE DESIGNATORS AND DID NOT DUPLICATE FMEAs FOR BOTH THE PORT AND STARBOARD SYSTEMS. THEREFORE, SINCE IOA DOES, IOA HAS TWO FMEAs THAT CORRESPOND TO ONE NASA FMEA. FOR ASSESSMENT PURPOSES THE BOTH PORT AND STARBOARD IOA FMEAs WERE COMPARED TO THE EQUIVALENT NASA FMEA SINCE THE EFFECT WOULD BE THE SAME WHETHER IT BE A PORT OR A STARBOARD FAILURE.

APPENDIX C
ASSESSMENT WORKSHEET

ASSESSMENT DATE: 1/29/88
 ASSESSMENT ID: RMS-4118
 NASA FMEA #: 05-6IB-MPM-5

NASA DATA:
 BASELINE []
 NEW [X]

SUBSYSTEM: RMS/EPD&C
 MDAC ID: 4118
 ITEM: HYBRID RELAY, K60

LEAD ANALYST: ROBINSON

ASSESSMENT:

	CRITICALITY FLIGHT HDW/FUNC	REDUNDANCY SCREENS			CIL ITEM
		A	B	C	
NASA	[1 / 1]	[N]	[N]	[N]	[X] *
IOA	[1 / 1]	[]	[]	[]	[X]
COMPARE	[/]	[N]	[N]	[N]	[]

RECOMMENDATIONS: (If different from NASA)

[/] [] [] [] []
 (ADD/DELETE)

* CIL RETENTION RATIONALE: (If applicable)

ADEQUATE []
 INADEQUATE []

REMARKS:

UNTIMELY OPERATION OF A DEPLOY ACTUATOR MOTOR COULD CAUSE PHYSICAL DAMAGE TO THE RMS/PAYLOADS/ORBITER. LOSS OF MISSION AND POSSIBLY LOSS OF CREW/VEHICLE COULD RESULT. THE NASA POST 51L FMEAs DO NOT SPECIFY REFERENCE DESIGNATORS AND DO NOT DUPLICATE FMEAs FOR PORT AND STARBOARD SYSTEMS. THEREFORE, SINCE IOA DOES, IOA HAS TWO FMEAs THAT CORRESPOND TO ONE NASA POST 51L FMEA. FOR ASSESSMENT PURPOSES THE BOTH IOA FMEAs WERE COMPARED TO THE SAME ONE NASA FMEA.

IOA RECOMMENDS COMBINING THE COMPONENTS ON THE FOLLOWING IOA FMEAs INTO ONE (1) FMEA FOR ASSESSMENT PURPOSES: 4114, 4116, 4118, 4120, 4122, 4124, 4126 AND 4128.

APPENDIX C
ASSESSMENT WORKSHEET

ASSESSMENT DATE: 1/15/88	NASA DATA:
ASSESSMENT ID: RMS-4119	BASELINE []
NASA FMEA #: 05-6IB-MPM-4	NEW [X]

SUBSYSTEM: RMS/EPD&C
MDAC ID: 4119
ITEM: HYBRID RELAY, K51

LEAD ANALYST: ROBINSON

ASSESSMENT:

	CRITICALITY FLIGHT HDW/FUNC	REDUNDANCY SCREENS			CIL ITEM
		A	B	C	
NASA	[3 /1R]	[P]	[P]	[P]	[] *
IOA	[3 /2R]	[]	[P]	[P]	[]
COMPARE	[/N]	[N]	[]	[]	[]

RECOMMENDATIONS: (If different from NASA)

[/] [] [] [] []
(ADD/DELETE)

* CIL RETENTION RATIONALE: (If applicable)

ADEQUATE []
INADEQUATE []

REMARKS:

UPGRADE IOA CRIT TO 3/1R AND COMBINE IOA FMEAs TO INCLUDE LIKE CORRESPONDING COMPONENTS FOR PORT AND STARBOARD SYSTEMS. IOA CONCURS WITH NASA POST 51L CRIT 3/1R. THE NASA FMEAs DO NOT SPECIFY REFERENCE DESIGNATORS AND DID NOT DUPLICATE FMEAs FOR BOTH THE PORT AND STARBOARD SYSTEMS. THEREFORE, SINCE IOA DOES, IOA HAS TWO FMEAs THAT CORRESPOND TO ONE NASA FMEA. FOR ASSESSMENT PURPOSES THE BOTH PORT AND STARBOARD IOA FMEAs WERE COMPARED TO THE EQUIVALENT NASA FMEA SINCE THE EFFECT WOULD BE THE SAME WHETHER IT BE A PORT OR A STARBOARD FAILURE.

APPENDIX C
ASSESSMENT WORKSHEET

ASSESSMENT DATE: 1/29/88
 ASSESSMENT ID: RMS-4120
 NASA FMEA #: 05-6IB-MPM-5

NASA DATA:
 BASELINE []
 NEW [X]

SUBSYSTEM: RMS/EPD&C
 MDAC ID: 4120
 ITEM: HYBRID RELAY, K51

LEAD ANALYST: ROBINSON

ASSESSMENT:

	CRITICALITY FLIGHT HDW/FUNC	REDUNDANCY SCREENS			CIL ITEM
		A	B	C	
NASA	[1 / 1]	[N]	[N]	[N]	[X] *
IOA	[1 / 1]	[]	[]	[]	[X]
COMPARE	[/]	[N]	[N]	[N]	[]

RECOMMENDATIONS: (If different from NASA)

[/] [] [] [] []
 (ADD/DELETE)

* CIL RETENTION RATIONALE: (If applicable)

ADEQUATE []
 INADEQUATE []

REMARKS:

UNTIMELY OPERATION OF A DEPLOY ACTUATOR MOTOR COULD CAUSE PHYSICAL DAMAGE TO THE RMS/PAYLOADS/ORBITER. LOSS OF MISSION AND POSSIBLY LOSS OF CREW/VEHICLE COULD RESULT. THE NASA POST 51L FMEAs DO NOT SPECIFY REFERENCE DESIGNATORS AND DO NOT DUPLICATE FMEAs FOR PORT AND STARBOARD SYSTEMS. THEREFORE, SINCE IOA DOES, IOA HAS TWO FMEAs THAT CORRESPOND TO ONE NASA POST 51L FMEA. FOR ASSESSMENT PURPOSES THE BOTH IOA FMEAs WERE COMPARED TO THE SAME ONE NASA FMEA.

IOA RECOMMENDS COMBINING THE COMPONENTS ON THE FOLLOWING IOA FMEAs INTO ONE (1) FMEA FOR ASSESSMENT PURPOSES: 4114, 4116, 4118, 4120, 4122, 4124, 4126 AND 4128.

APPENDIX C
ASSESSMENT WORKSHEET

ASSESSMENT DATE: 1/29/88
 ASSESSMENT ID: RMS-4122
 NASA FMEA #: 05-6IB-MPM-5

NASA DATA:
 BASELINE []
 NEW [X]

SUBSYSTEM: RMS/EPD&C
 MDAC ID: 4122
 ITEM: HYBRID RELAY, K22

LEAD ANALYST: ROBINSON

ASSESSMENT:

	CRITICALITY FLIGHT HDW/FUNC	REDUNDANCY SCREENS			CIL ITEM
		A	B	C	
NASA	[1 / 1]	[N]	[N]	[N]	[X] *
IOA	[1 / 1]	[]	[]	[]	[X]
COMPARE	[/]	[N]	[N]	[N]	[]

RECOMMENDATIONS: (If different from NASA)

[/] [] [] [] []
 (ADD/DELETE)

* CIL RETENTION RATIONALE: (If applicable)

ADEQUATE []
 INADEQUATE []

REMARKS:

UNTIMELY OPERATION OF A DEPLOY ACTUATOR MOTOR COULD CAUSE PHYSICAL DAMAGE TO THE RMS/PAYLOADS/ORBITER. LOSS OF MISSION AND POSSIBLY LOSS OF CREW/VEHICLE COULD RESULT. THE NASA POST 51L FMEAs DO NOT SPECIFY REFERENCE DESIGNATORS AND DO NOT DUPLICATE FMEAs FOR PORT AND STARBOARD SYSTEMS. THEREFORE, SINCE IOA DOES, IOA HAS TWO FMEAs THAT CORRESPOND TO ONE NASA POST 51L FMEA. FOR ASSESSMENT PURPOSES THE BOTH IOA FMEAs WERE COMPARED TO THE SAME ONE NASA FMEA.

IOA RECOMMENDS COMBINING THE COMPONENTS ON THE FOLLOWING IOA FMEAs INTO ONE (1) FMEA FOR ASSESSMENT PURPOSES: 4114, 4116, 4118, 4120, 4122, 4124, 4126 AND 4128.

APPENDIX C
ASSESSMENT WORKSHEET

ASSESSMENT DATE: 1/15/88
 ASSESSMENT ID: RMS-4123
 NASA FMEA #: 05-6IB-MPM-4

NASA DATA:
 BASELINE []
 NEW [X]

SUBSYSTEM: RMS/EPD&C
 MDAC ID: 4123
 ITEM: HYBRID RELAY, K62

LEAD ANALYST: ROBINSON

ASSESSMENT:

	CRITICALITY FLIGHT HDW/FUNC	REDUNDANCY SCREENS			CIL ITEM
		A	B	C	
NASA	[3 /1R]	[P]	[P]	[P]	[] *
IOA	[3 /2R]	[]	[P]	[P]	[]
COMPARE	[/N]	[N]	[]	[]	[]

RECOMMENDATIONS: (If different from NASA)

[/] [] [] [] []
 (ADD/DELETE)

* CIL RETENTION RATIONALE: (If applicable)

ADEQUATE []
 INADEQUATE []

REMARKS:

UPGRADE IOA CRIT TO 3/1R AND COMBINE IOA FMEAs TO INCLUDE LIKE CORRESPONDING COMPONENTS FOR PORT AND STARBOARD SYSTEMS. IOA CONCURS WITH NASA POST 51L CRIT 3/1R. THE NASA FMEAs DO NOT SPECIFY REFERENCE DESIGNATORS AND DID NOT DUPLICATE FMEAs FOR BOTH THE PORT AND STARBOARD SYSTEMS. THEREFORE, SINCE IOA DOES, IOA HAS TWO FMEAs THAT CORRESPOND TO ONE NASA FMEA. FOR ASSESSMENT PURPOSES THE BOTH PORT AND STARBOARD IOA FMEAs WERE COMPARED TO THE EQUIVALENT NASA FMEA SINCE THE EFFECT WOULD BE THE SAME WHETHER IT BE A PORT OR A STARBOARD FAILURE.

APPENDIX C
ASSESSMENT WORKSHEET

ASSESSMENT DATE: 1/29/88
 ASSESSMENT ID: RMS-4124
 NASA FMEA #: 05-6IB-MPM-5

NASA DATA:
 BASELINE []
 NEW [X]

SUBSYSTEM: RMS/EPD&C
 MDAC ID: 4124
 ITEM: HYBRID RELAY, K62

LEAD ANALYST: ROBINSON

ASSESSMENT:

	CRITICALITY FLIGHT HDW/FUNC	REDUNDANCY SCREENS			CIL ITEM
		A	B	C	
NASA	[1 / 1]	[N]	[N]	[N]	[X] *
IOA	[1 / 1]	[]	[]	[]	[X]
COMPARE	[/]	[N]	[N]	[N]	[]

RECOMMENDATIONS: (If different from NASA)

[/] [] [] [] []
 (ADD/DELETE)

* CIL RETENTION RATIONALE: (If applicable)

ADEQUATE []
 INADEQUATE []

REMARKS:

UNTIMELY OPERATION OF A DEPLOY ACTUATOR MOTOR COULD CAUSE PHYSICAL DAMAGE TO THE RMS/PAYLOADS/ORBITER. LOSS OF MISSION AND POSSIBLY LOSS OF CREW/VEHICLE COULD RESULT. THE NASA POST 51L FMEAs DO NOT SPECIFY REFERENCE DESIGNATORS AND DO NOT DUPLICATE FMEAs FOR PORT AND STARBOARD SYSTEMS. THEREFORE, SINCE IOA DOES, IOA HAS TWO FMEAs THAT CORRESPOND TO ONE NASA POST 51L FMEA. FOR ASSESSMENT PURPOSES THE BOTH IOA FMEAs WERE COMPARED TO THE SAME ONE NASA FMEA.

IOA RECOMMENDS COMBINING THE COMPONENTS ON THE FOLLOWING IOA FMEAs INTO ONE (1) FMEA FOR ASSESSMENT PURPOSES: 4114, 4116, 4118, 4120, 4122, 4124, 4126 AND 4128.

APPENDIX C
ASSESSMENT WORKSHEET

ASSESSMENT DATE: 1/15/88
 ASSESSMENT ID: RMS-4125
 NASA FMEA #: 05-6IB-MPM-4

NASA DATA:
 BASELINE []
 NEW [X]

SUBSYSTEM: RMS/EPD&C
 MDAC ID: 4125
 ITEM: HYBRID RELAY, K24

LEAD ANALYST: ROBINSON

ASSESSMENT:

	CRITICALITY FLIGHT HDW/FUNC	REDUNDANCY SCREENS			CIL ITEM
		A	B	C	
NASA	[3 /1R]	[P]	[P]	[P]	[] *
IOA	[3 /2R]	[]	[P]	[P]	[]
COMPARE	[/N]	[N]	[]	[]	[]

RECOMMENDATIONS: (If different from NASA)

[/] [] [] [] []
 (ADD/DELETE)

* CIL RETENTION RATIONALE: (If applicable)

ADEQUATE []
 INADEQUATE []

REMARKS:

UPGRADE IOA CRIT TO 3/1R AND COMBINE IOA FMEAs TO INCLUDE LIKE CORRESPONDING COMPONENTS FOR PORT AND STARBOARD SYSTEMS. IOA CONCURS WITH NASA POST 51L CRIT 3/1R. THE NASA FMEAs DO NOT SPECIFY REFERENCE DESIGNATORS AND DID NOT DUPLICATE FMEAs FOR BOTH THE PORT AND STARBOARD SYSTEMS. THEREFORE, SINCE IOA DOES, IOA HAS TWO FMEAs THAT CORRESPOND TO ONE NASA FMEA. FOR ASSESSMENT PURPOSES THE BOTH PORT AND STARBOARD IOA FMEAs WERE COMPARED TO THE EQUIVALENT NASA FMEA SINCE THE EFFECT WOULD BE THE SAME WHETHER IT BE A PORT OR A STARBOARD FAILURE.

APPENDIX C
ASSESSMENT WORKSHEET

ASSESSMENT DATE: 1/29/88
 ASSESSMENT ID: RMS-4126
 NASA FMEA #: 05-6IB-MPM-5

NASA DATA:
 BASELINE []
 NEW [X]

SUBSYSTEM: RMS/EPD&C
 MDAC ID: 4126
 ITEM: HYBRID RELAY, K24

LEAD ANALYST: ROBINSON

ASSESSMENT:

	CRITICALITY FLIGHT HDW/FUNC	REDUNDANCY SCREENS			CIL ITEM
		A	B	C	
NASA	[1 / 1]	[N]	[N]	[N]	[X] *
IOA	[1 / 1]	[]	[]	[]	[X]
COMPARE	[/]	[N]	[N]	[N]	[]

RECOMMENDATIONS: (If different from NASA)

[/] [] [] [] [] (ADD/DELETE)

* CIL RETENTION RATIONALE: (If applicable)

ADEQUATE []
 INADEQUATE []

REMARKS:

UNTIMELY OPERATION OF A DEPLOY ACTUATOR MOTOR COULD CAUSE PHYSICAL DAMAGE TO THE RMS/PAYLOADS/ORBITER. LOSS OF MISSION AND POSSIBLY LOSS OF CREW/VEHICLE COULD RESULT. THE NASA POST 51L FMEAs DO NOT SPECIFY REFERENCE DESIGNATORS AND DO NOT DUPLICATE FMEAs FOR PORT AND STARBOARD SYSTEMS. THEREFORE, SINCE IOA DOES, IOA HAS TWO FMEAs THAT CORRESPOND TO ONE NASA POST 51L FMEA. FOR ASSESSMENT PURPOSES THE BOTH IOA FMEAs WERE COMPARED TO THE SAME ONE NASA FMEA.

IOA RECOMMENDS COMBINING THE COMPONENTS ON THE FOLLOWING IOA FMEAs INTO ONE (1) FMEA FOR ASSESSMENT PURPOSES: 4114, 4116, 4118, 4120, 4122, 4124, 4126 AND 4128.

APPENDIX C
ASSESSMENT WORKSHEET

ASSESSMENT DATE: 1/15/88
ASSESSMENT ID: RMS-4127
NASA FMEA #: 05-6IB-MPM-4

NASA DATA:
BASELINE []
NEW [X]

SUBSYSTEM: RMS/EPD&C
MDAC ID: 4127
ITEM: HYBRID RELAY, K50

LEAD ANALYST: ROBINSON

ASSESSMENT:

	CRITICALITY FLIGHT HDW/FUNC	REDUNDANCY SCREENS			CIL ITEM
		A	B	C	
NASA	[3 /1R]	[P]	[P]	[P]	[] *
IOA	[3 /2R]	[]	[P]	[P]	[]
COMPARE	[/N]	[N]	[]	[]	[]

RECOMMENDATIONS: (If different from NASA)

[/] [] [] [] []
(ADD/DELETE)

* CIL RETENTION RATIONALE: (If applicable)

ADEQUATE []
INADEQUATE []

REMARKS:

UPGRADE IOA CRIT TO 3/1R AND COMBINE IOA FMEAs TO INCLUDE LIKE CORRESPONDING COMPONENTS FOR PORT AND STARBOARD SYSTEMS. IOA CONCURS WITH NASA POST 51L CRIT 3/1R. THE NASA FMEAs DO NOT SPECIFY REFERENCE DESIGNATORS AND DID NOT DUPLICATE FMEAs FOR BOTH THE PORT AND STARBOARD SYSTEMS. THEREFORE, SINCE IOA DOES, IOA HAS TWO FMEAs THAT CORRESPOND TO ONE NASA FMEA. FOR ASSESSMENT PURPOSES THE BOTH PORT AND STARBOARD IOA FMEAs WERE COMPARED TO THE EQUIVALENT NASA FMEA SINCE THE EFFECT WOULD BE THE SAME WHETHER IT BE A PORT OR A STARBOARD FAILURE.

APPENDIX C
ASSESSMENT WORKSHEET

ASSESSMENT DATE: 1/29/88
 ASSESSMENT ID: RMS-4128
 NASA FMEA #: 05-6IB-MPM-5

NASA DATA:
 BASELINE []
 NEW [X]

SUBSYSTEM: RMS/EPD&C
 MDAC ID: 4128
 ITEM: HYBRID RELAY, K50

LEAD ANALYST: ROBINSON

ASSESSMENT:

	CRITICALITY FLIGHT HDW/FUNC	REDUNDANCY SCREENS			CIL ITEM
		A	B	C	
NASA	[1 / 1]	[N]	[N]	[N]	[X] *
IOA	[1 / 1]	[]	[]	[]	[X]
COMPARE	[/]	[N]	[N]	[N]	[]

RECOMMENDATIONS: (If different from NASA)

[/] [] [] [] []
 (ADD/DELETE)

* CIL RETENTION RATIONALE: (If applicable)

ADEQUATE []
 INADEQUATE []

REMARKS:

UNTIMELY OPERATION OF A DEPLOY ACTUATOR MOTOR COULD CAUSE PHYSICAL DAMAGE TO THE RMS/PAYLOADS/ORBITER. LOSS OF MISSION AND POSSIBLY LOSS OF CREW/VEHICLE COULD RESULT. THE NASA POST 51L FMEAs DO NOT SPECIFY REFERENCE DESIGNATORS AND DO NOT DUPLICATE FMEAs FOR PORT AND STARBOARD SYSTEMS. THEREFORE, SINCE IOA DOES, IOA HAS TWO FMEAs THAT CORRESPOND TO ONE NASA POST 51L FMEA. FOR ASSESSMENT PURPOSES THE BOTH IOA FMEAs WERE COMPARED TO THE SAME ONE NASA FMEA.

IOA RECOMMENDS COMBINING THE COMPONENTS ON THE FOLLOWING IOA FMEAs INTO ONE (1) FMEA FOR ASSESSMENT PURPOSES: 4114, 4116, 4118, 4120, 4122, 4124, 4126 AND 4128.

APPENDIX C
ASSESSMENT WORKSHEET

ASSESSMENT DATE: 1/19/88
 ASSESSMENT ID: RMS-4129
 NASA FMEA #: 05-6IB-MPM-10

NASA DATA:
 BASELINE []
 NEW [X]

SUBSYSTEM: RMS/EPD&C
 MDAC ID: 4129
 ITEM: HYBRID DRIVERS, AR9, 11

LEAD ANALYST: ROBINSON

ASSESSMENT:

	CRITICALITY FLIGHT HDW/FUNC	REDUNDANCY SCREENS			CIL ITEM
		A	B	C	
NASA	[3 / 3]	[N]	[N]	[N]	[] *
IOA	[3 / 3]	[]	[]	[]	[]
COMPARE	[/]	[N]	[N]	[N]	[]

RECOMMENDATIONS: (If different from NASA)

[/] [] [] [] []
 (ADD/DELETE)

* CIL RETENTION RATIONALE: (If applicable)

ADEQUATE []
 INADEQUATE []

REMARKS:

NO ISSUE. ONE POST 51L NASA FMEA ANALYZED THE FAILURE MODE RELATIVE TO FAILURE OF THE TOTAL INDICATION CIRCUIT SUCH THAT IT PROVIDED ERRONEOUS INDICATION. IOA FMEAs ANALYZED THE FAILURE MODE RELATIVE TO EACH INDIVIDUAL COMPONENTS IN THE CIRCUIT. IN CONSIDERATION THAT THE CRITICALITIES INVOLVED ARE ALL 3/3, THE FMEA DOES NOT REQUIRE ASSESSMENT. IOA RECOMMENDS COMBINING THE INDIVIDUAL IOA FMEAs INTO ONE.

APPENDIX C
ASSESSMENT WORKSHEET

ASSESSMENT DATE: 1/19/88
 ASSESSMENT ID: RMS-4130
 NASA FMEA #: 05-6IB-MPM-10

NASA DATA:
 BASELINE []
 NEW [X]

SUBSYSTEM: RMS/EPD&C
 MDAC ID: 4130
 ITEM: HYBRID DRIVERS, AR9, 11

LEAD ANALYST: ROBINSON

ASSESSMENT:

	CRITICALITY FLIGHT HDW/FUNC	REDUNDANCY SCREENS			CIL ITEM
		A	B	C	
NASA	[3 / 3]	[N]	[N]	[N]	[] *
IOA	[3 / 3]	[]	[]	[]	[]
COMPARE	[/]	[N]	[N]	[N]	[]

RECOMMENDATIONS: (If different from NASA)

[/] [] [] [] []
 (ADD/DELETE)

* CIL RETENTION RATIONALE: (If applicable)

ADEQUATE []
 INADEQUATE []

REMARKS:

NO ISSUE. ONE POST 51L NASA FMEA ANALYZED THE FAILURE MODE
 RELATIVE TO FAILURE OF THE TOTAL INDICATION CIRCUIT SUCH THAT IT
 PROVIDED ERRONEOUS INDICATION. IOA FMEAs ANALYZED THE FAILURE
 MODE RELATIVE TO EACH INDIVIDUAL COMPONENTS IN THE CIRCUIT.
 IN CONSIDERATION THAT THE CRITICALITIES INVOLVED ARE ALL 3/3, THE
 FMEA DOES NOT REQUIRE ASSESSMENT. IOA RECOMMENDS COMBINING THE
 INDIVIDUAL IOA FMEAs.

APPENDIX C
ASSESSMENT WORKSHEET

ASSESSMENT DATE: 1/19/88
 ASSESSMENT ID: RMS-4131
 NASA FMEA #: 05-6IB-MPM-10

NASA DATA:
 BASELINE []
 NEW [X]

SUBSYSTEM: RMS/EPD&C
 MDAC ID: 4131
 ITEM: HYBRID DRIVERS, AR13, 15

LEAD ANALYST: ROBINSON

ASSESSMENT:

	CRITICALITY FLIGHT HDW/FUNC	REDUNDANCY SCREENS			CIL ITEM
		A	B	C	
NASA	[3 / 3]	[N]	[N]	[N]	[] *
IOA	[3 / 3]	[]	[]	[]	[]
COMPARE	[/]	[N]	[N]	[N]	[]

RECOMMENDATIONS: (If different from NASA)

[/] [] [] [] []
 (ADD/DELETE)

* CIL RETENTION RATIONALE: (If applicable)

ADEQUATE []
 INADEQUATE []

REMARKS:

NO ISSUE. ONE POST 51L NASA FMEA ANALYZED THE FAILURE MODE RELATIVE TO FAILURE OF THE TOTAL INDICATION CIRCUIT SUCH THAT IT PROVIDED ERRONEOUS INDICATION. IOA FMEAs ANALYZED THE FAILURE MODE RELATIVE TO EACH INDIVIDUAL COMPONENTS IN THE CIRCUIT. IN CONSIDERATION THAT THE CRITICALITIES INVOLVED ARE ALL 3/3, THE FMEA DOES NOT REQUIRE ASSESSMENT. IOA RECOMMENDS COMBINING THE INDIVIDUAL IOA FMEAs.

APPENDIX C
ASSESSMENT WORKSHEET

ASSESSMENT DATE: 1/19/88
 ASSESSMENT ID: RMS-4132
 NASA FMEA #: 05-6IB-MPM-10

NASA DATA:
 BASELINE []
 NEW [X]

SUBSYSTEM: RMS/EPD&C
 MDAC ID: 4132
 ITEM: HYBRID DRIVERS, AR13, 15

LEAD ANALYST: ROBINSON

ASSESSMENT:

	CRITICALITY FLIGHT HDW/FUNC	REDUNDANCY SCREENS			CIL ITEM
		A	B	C	
NASA	[3 / 3]	[N]	[N]	[N]	[] *
IOA	[3 / 3]	[]	[]	[]	[]
COMPARE	[/]	[N]	[N]	[N]	[]

RECOMMENDATIONS: (If different from NASA)

[/] [] [] [] []
 (ADD/DELETE)

* CIL RETENTION RATIONALE: (If applicable)

ADEQUATE []
 INADEQUATE []

REMARKS:

NO ISSUE. ONE POST 51L NASA FMEA ANALYZED THE FAILURE MODE
 RELATIVE TO FAILURE OF THE TOTAL INDICATION CIRCUIT SUCH THAT IT
 PROVIDED ERRONEOUS INDICATION. IOA FMEAs ANALYZED THE FAILURE
 MODE RELATIVE TO EACH INDIVIDUAL COMPONENTS IN THE CIRCUIT.
 IN CONSIDERATION THAT THE CRITICALITIES INVOLVED ARE ALL 3/3, THE
 FMEA DOES NOT REQUIRE ASSESSMENT. IOA RECOMMENDS COMBINING THE
 INDIVIDUAL IOA FMEAs.

APPENDIX C
ASSESSMENT WORKSHEET

ASSESSMENT DATE: 1/19/88
 ASSESSMENT ID: RMS-4133
 NASA FMEA #: 05-6IB-MPM-10

NASA DATA:
 BASELINE []
 NEW [X]

SUBSYSTEM: RMS/EPD&C
 MDAC ID: 4133
 ITEM: HYBRID DRIVERS, AR8, 10

LEAD ANALYST: ROBINSON

ASSESSMENT:

	CRITICALITY FLIGHT HDW/FUNC	REDUNDANCY SCREENS			CIL ITEM
		A	B	C	
NASA	[3 /3]	[N]	[N]	[N]	[] *
IOA	[3 /3]	[]	[]	[]	[]
COMPARE	[/]	[N]	[N]	[N]	[]

RECOMMENDATIONS: (If different from NASA)

[/] [] [] [] []
 (ADD/DELETE)

* CIL RETENTION RATIONALE: (If applicable)

ADEQUATE []
 INADEQUATE []

REMARKS:

NO ISSUE. ONE POST 51L NASA FMEA ANALYZED THE FAILURE MODE RELATIVE TO FAILURE OF THE TOTAL INDICATION CIRCUIT SUCH THAT IT PROVIDED ERRONEOUS INDICATION. IOA FMEAs ANALYZED THE FAILURE MODE RELATIVE TO EACH INDIVIDUAL COMPONENTS IN THE CIRCUIT. IN CONSIDERATION THAT THE CRITICALITIES INVOLVED ARE ALL 3/3, THE FMEA DOES NOT REQUIRE ASSESSMENT. IOA RECOMMENDS COMBINING THE INDIVIDUAL IOA FMEAs.

APPENDIX C
ASSESSMENT WORKSHEET

ASSESSMENT DATE: 1/19/88
 ASSESSMENT ID: RMS-4134
 NASA FMEA #: 05-6IB-MPM-10

NASA DATA:
 BASELINE []
 NEW [X]

SUBSYSTEM: RMS/EPD&C
 MDAC ID: 4134
 ITEM: HYBRID DRIVERS, AR8, 10

LEAD ANALYST: ROBINSON

ASSESSMENT:

	CRITICALITY FLIGHT HDW/FUNC	REDUNDANCY SCREENS			CIL ITEM
		A	B	C	
NASA	[3 / 3]	[N]	[N]	[N]	[] *
IOA	[3 / 3]	[]	[]	[]	[]
COMPARE	[/]	[N]	[N]	[N]	[]

RECOMMENDATIONS: (If different from NASA)

[/] [] [] [] []
 (ADD/DELETE)

* CIL RETENTION RATIONALE: (If applicable)

ADEQUATE []
 INADEQUATE []

REMARKS:

NO ISSUE. ONE POST 51L NASA FMEA ANALYZED THE FAILURE MODE
 RELATIVE TO FAILURE OF THE TOTAL INDICATION CIRCUIT SUCH THAT IT
 PROVIDED ERRONEOUS INDICATION. IOA FMEAs ANALYZED THE FAILURE
 MODE RELATIVE TO EACH INDIVIDUAL COMPONENTS IN THE CIRCUIT.
 IN CONSIDERATION THAT THE CRITICALITIES INVOLVED ARE ALL 3/3, THE
 FMEA DOES NOT REQUIRE ASSESSMENT. IOA RECOMMENDS COMBINING THE
 INDIVIDUAL IOA FMEAs.

APPENDIX C
ASSESSMENT WORKSHEET

ASSESSMENT DATE: 1/19/88
 ASSESSMENT ID: RMS-4135
 NASA FMEA #: 05-6IB-MPM-10

NASA DATA:
 BASELINE []
 NEW [X]

SUBSYSTEM: RMS/EPD&C
 MDAC ID: 4135
 ITEM: HYBRID DRIVERS, AR12, 14

LEAD ANALYST: ROBINSON

ASSESSMENT:

	CRITICALITY FLIGHT HDW/FUNC	REDUNDANCY SCREENS			CIL ITEM
		A	B	C	
NASA	[3 / 3]	[N]	[N]	[N]	[] *
IOA	[3 / 3]	[]	[]	[]	[]
COMPARE	[/]	[N]	[N]	[N]	[]

RECOMMENDATIONS: (If different from NASA)

[/] [] [] [] []
 (ADD/DELETE)

* CIL RETENTION RATIONALE: (If applicable)

ADEQUATE []
 INADEQUATE []

REMARKS:

NO ISSUE. ONE POST 51L NASA FMEA ANALYZED THE FAILURE MODE RELATIVE TO FAILURE OF THE TOTAL INDICATION CIRCUIT SUCH THAT IT PROVIDED ERRONEOUS INDICATION. IOA FMEAs ANALYZED THE FAILURE MODE RELATIVE TO EACH INDIVIDUAL COMPONENTS IN THE CIRCUIT. IN CONSIDERATION THAT THE CRITICALITIES INVOLVED ARE ALL 3/3, THE FMEA DOES NOT REQUIRE ASSESSMENT. IOA RECOMMENDS COMBINING THE INDIVIDUAL IOA FMEAs.

APPENDIX C
ASSESSMENT WORKSHEET

ASSESSMENT DATE: 1/19/88
 ASSESSMENT ID: RMS-4136
 NASA FMEA #: 05-6IB-MPM-10

NASA DATA:
 BASELINE []
 NEW [X]

SUBSYSTEM: RMS/EPD&C
 MDAC ID: 4136
 ITEM: HYBRID DRIVERS, AR12, 14

LEAD ANALYST: ROBINSON

ASSESSMENT:

	CRITICALITY FLIGHT HDW/FUNC	REDUNDANCY SCREENS			CIL ITEM
		A	B	C	
NASA	[3 / 3]	[N]	[N]	[N]	[] *
IOA	[3 / 3]	[]	[]	[]	[]
COMPARE	[/]	[N]	[N]	[N]	[]

RECOMMENDATIONS: (If different from NASA)

[/] [] [] [] []
 (ADD/DELETE)

* CIL RETENTION RATIONALE: (If applicable)

ADEQUATE []
 INADEQUATE []

REMARKS:

NO ISSUE. ONE POST 51L NASA FMEA ANALYZED THE FAILURE MODE
 RELATIVE TO FAILURE OF THE TOTAL INDICATION CIRCUIT SUCH THAT IT
 PROVIDED ERRONEOUS INDICATION. IOA FMEAs ANALYZED THE FAILURE
 MODE RELATIVE TO EACH INDIVIDUAL COMPONENTS IN THE CIRCUIT.
 IN CONSIDERATION THAT THE CRITICALITIES INVOLVED ARE ALL 3/3, THE
 FMEA DOES NOT REQUIRE ASSESSMENT. IOA RECOMMENDS COMBINING THE
 INDIVIDUAL IOA FMEAs.

APPENDIX C
ASSESSMENT WORKSHEET

ASSESSMENT DATE: 1/19/88
 ASSESSMENT ID: RMS-4137
 NASA FMEA #: 05-6IB-MPM-10

NASA DATA:
 BASELINE []
 NEW [X]

SUBSYSTEM: RMS/EPD&C
 MDAC ID: 4137
 ITEM: HYBRID DRIVERS, AR14, 18

LEAD ANALYST: ROBINSON

ASSESSMENT:

	CRITICALITY FLIGHT HDW/FUNC	REDUNDANCY SCREENS			CIL ITEM
		A	B	C	
NASA	[3 / 3]	[N]	[N]	[N]	[] *
IOA	[3 / 3]	[]	[]	[]	[]
COMPARE	[/]	[N]	[N]	[N]	[]

RECOMMENDATIONS: (If different from NASA)

[/] [] [] [] []
 (ADD/DELETE)

* CIL RETENTION RATIONALE: (If applicable)

ADEQUATE []
 INADEQUATE []

REMARKS:

NO ISSUE. ONE POST 51L NASA FMEA ANALYZED THE FAILURE MODE RELATIVE TO FAILURE OF THE TOTAL INDICATION CIRCUIT SUCH THAT IT PROVIDED ERRONEOUS INDICATION. IOA FMEAs ANALYZED THE FAILURE MODE RELATIVE TO EACH INDIVIDUAL COMPONENTS IN THE CIRCUIT. IN CONSIDERATION THAT THE CRITICALITIES INVOLVED ARE ALL 3/3, THE FMEA DOES NOT REQUIRE ASSESSMENT. IOA RECOMMENDS COMBINING THE INDIVIDUAL IOA FMEAs.

APPENDIX C
ASSESSMENT WORKSHEET

ASSESSMENT DATE: 1/19/88
 ASSESSMENT ID: RMS-4138
 NASA FMEA #: 05-6IB-MPM-10

NASA DATA:
 BASELINE []
 NEW [X]

SUBSYSTEM: RMS/EPD&C
 MDAC ID: 4138
 ITEM: HYBRID DRIVERS, AR14, 18

LEAD ANALYST: ROBINSON

ASSESSMENT:

	CRITICALITY FLIGHT HDW/FUNC	REDUNDANCY SCREENS			CIL ITEM
		A	B	C	
NASA	[3 / 3]	[N]	[N]	[N]	[] *
IOA	[3 / 3]	[]	[]	[]	[]
COMPARE	[/]	[N]	[N]	[N]	[]

RECOMMENDATIONS: (If different from NASA)

[/] [] [] [] []
 (ADD/DELETE)

* CIL RETENTION RATIONALE: (If applicable)

ADEQUATE []
 INADEQUATE []

REMARKS:

NO ISSUE. ONE POST 51L NASA FMEA ANALYZED THE FAILURE MODE
 RELATIVE TO FAILURE OF THE TOTAL INDICATION CIRCUIT SUCH THAT IT
 PROVIDED ERRONEOUS INDICATION. IOA FMEAs ANALYZED THE FAILURE
 MODE RELATIVE TO EACH INDIVIDUAL COMPONENTS IN THE CIRCUIT.
 IN CONSIDERATION THAT THE CRITICALITIES INVOLVED ARE ALL 3/3, THE
 FMEA DOES NOT REQUIRE ASSESSMENT. IOA RECOMMENDS COMBINING THE
 INDIVIDUAL IOA FMEAs.

APPENDIX C
ASSESSMENT WORKSHEET

ASSESSMENT DATE: 1/19/88
 ASSESSMENT ID: RMS-4139
 NASA FMEA #: 05-6IB-MPM-10

NASA DATA:
 BASELINE []
 NEW [X]

SUBSYSTEM: RMS/EPD&C
 MDAC ID: 4139
 ITEM: HYBRID DRIVERS, AR6, 8

LEAD ANALYST: ROBINSON

ASSESSMENT:

	CRITICALITY FLIGHT HDW/FUNC	REDUNDANCY SCREENS			CIL ITEM
		A	B	C	
NASA	[3 / 3]	[N]	[N]	[N]	[] *
IOA	[3 / 3]	[]	[]	[]	[]
COMPARE	[/]	[N]	[N]	[N]	[]

RECOMMENDATIONS: (If different from NASA)

[/] [] [] [] []
 (ADD/DELETE)

* CIL RETENTION RATIONALE: (If applicable)

ADEQUATE []
 INADEQUATE []

REMARKS:

NO ISSUE. ONE POST 51L NASA FMEA ANALYZED THE FAILURE MODE RELATIVE TO FAILURE OF THE TOTAL INDICATION CIRCUIT SUCH THAT IT PROVIDED ERRONEOUS INDICATION. IOA FMEAs ANALYZED THE FAILURE MODE RELATIVE TO EACH INDIVIDUAL COMPONENTS IN THE CIRCUIT. IN CONSIDERATION THAT THE CRITICALITIES INVOLVED ARE ALL 3/3, THE FMEA DOES NOT REQUIRE ASSESSMENT. IOA RECOMMENDS COMBINING THE INDIVIDUAL IOA FMEAs.

APPENDIX C
ASSESSMENT WORKSHEET

ASSESSMENT DATE: 1/19/88
 ASSESSMENT ID: RMS-4140
 NASA FMEA #: 05-6IB-MPM-10

NASA DATA:
 BASELINE []
 NEW [X]

SUBSYSTEM: RMS/EPD&C
 MDAC ID: 4140
 ITEM: HYBRID DRIVERS, AR6, 8

LEAD ANALYST: ROBINSON

ASSESSMENT:

	CRITICALITY FLIGHT HDW/FUNC	REDUNDANCY SCREENS			CIL ITEM
		A	B	C	
NASA	[3 / 3]	[N]	[N]	[N]	[] *
IOA	[3 / 3]	[]	[]	[]	[]
COMPARE	[/]	[N]	[N]	[N]	[]

RECOMMENDATIONS: (If different from NASA)

[/] [] [] [] []
 (ADD/DELETE)

* CIL RETENTION RATIONALE: (If applicable)

ADEQUATE []
 INADEQUATE []

REMARKS:

NO ISSUE. ONE POST 51L NASA FMEA ANALYZED THE FAILURE MODE
 RELATIVE TO FAILURE OF THE TOTAL INDICATION CIRCUIT SUCH THAT IT
 PROVIDED ERRONEOUS INDICATION. IOA FMEAs ANALYZED THE FAILURE
 MODE RELATIVE TO EACH INDIVIDUAL COMPONENTS IN THE CIRCUIT.
 IN CONSIDERATION THAT THE CRITICALITIES INVOLVED ARE ALL 3/3, THE
 FMEA DOES NOT REQUIRE ASSESSMENT. IOA RECOMMENDS COMBINING THE
 INDIVIDUAL IOA FMEAs.

APPENDIX C
ASSESSMENT WORKSHEET

ASSESSMENT DATE: 1/19/88
 ASSESSMENT ID: RMS-4141
 NASA FMEA #: 05-6IB-MPM-10

NASA DATA:
 BASELINE []
 NEW [X]

SUBSYSTEM: RMS/EPD&C
 MDAC ID: 4141
 ITEM: HYBRID DRIVERS, AR12, 16

LEAD ANALYST: ROBINSON

ASSESSMENT:

	CRITICALITY FLIGHT HDW/FUNC	REDUNDANCY SCREENS			CIL ITEM
		A	B	C	
NASA	[3 / 3]	[N]	[N]	[N]	[] *
IOA	[3 / 3]	[]	[]	[]	[]
COMPARE	[/]	[N]	[N]	[N]	[]

RECOMMENDATIONS: (If different from NASA)

[/] [] [] [] []
 (ADD/DELETE)

* CIL RETENTION RATIONALE: (If applicable)

ADEQUATE []
 INADEQUATE []

REMARKS:

NO ISSUE. ONE POST 51L NASA FMEA ANALYZED THE FAILURE MODE RELATIVE TO FAILURE OF THE TOTAL INDICATION CIRCUIT SUCH THAT IT PROVIDED ERRONEOUS INDICATION. IOA FMEAs ANALYZED THE FAILURE MODE RELATIVE TO EACH INDIVIDUAL COMPONENTS IN THE CIRCUIT. IN CONSIDERATION THAT THE CRITICALITIES INVOLVED ARE ALL 3/3, THE FMEA DOES NOT REQUIRE ASSESSMENT. IOA RECOMMENDS COMBINING THE INDIVIDUAL IOA FMEAs.

APPENDIX C
ASSESSMENT WORKSHEET

ASSESSMENT DATE: 1/19/88
 ASSESSMENT ID: RMS-4142
 NASA FMEA #: 05-6IB-MPM-10

NASA DATA:
 BASELINE []
 NEW [X]

SUBSYSTEM: RMS/EPD&C
 MDAC ID: 4142
 ITEM: HYBRID DRIVERS, AR12, 16

LEAD ANALYST: ROBINSON

ASSESSMENT:

	CRITICALITY FLIGHT HDW/FUNC	REDUNDANCY SCREENS			CIL ITEM
		A	B	C	
NASA	[3 / 3]	[N]	[N]	[N]	[] *
IOA	[3 / 3]	[]	[]	[]	[]
COMPARE	[/]	[N]	[N]	[N]	[]

RECOMMENDATIONS: (If different from NASA)

[/] [] [] [] []
 (ADD/DELETE)

* CIL RETENTION RATIONALE: (If applicable)

ADEQUATE []
 INADEQUATE []

REMARKS:

NO ISSUE. ONE POST 51L NASA FMEA ANALYZED THE FAILURE MODE
 RELATIVE TO FAILURE OF THE TOTAL INDICATION CIRCUIT SUCH THAT IT
 PROVIDED ERRONEOUS INDICATION. IOA FMEAs ANALYZED THE FAILURE
 MODE RELATIVE TO EACH INDIVIDUAL COMPONENTS IN THE CIRCUIT.
 IN CONSIDERATION THAT THE CRITICALITIES INVOLVED ARE ALL 3/3, THE
 FMEA DOES NOT REQUIRE ASSESSMENT. IOA RECOMMENDS COMBINING THE
 INDIVIDUAL IOA FMEAs.

APPENDIX C
ASSESSMENT WORKSHEET

ASSESSMENT DATE: 1/19/88
 ASSESSMENT ID: RMS-4143
 NASA FMEA #: 05-6IB-MPM-10

NASA DATA:
 BASELINE []
 NEW [X]

SUBSYSTEM: RMS/EPD&C
 MDAC ID: 4143
 ITEM: HYBRID DRIVERS, AR2, 4

LEAD ANALYST: ROBINSON

ASSESSMENT:

	CRITICALITY FLIGHT HDW/FUNC	REDUNDANCY SCREENS			CIL ITEM
		A	B	C	
NASA	[3 / 3]	[N]	[N]	[N]	[] *
IOA	[3 / 3]	[]	[]	[]	[]
COMPARE	[/]	[N]	[N]	[N]	[]

RECOMMENDATIONS: (If different from NASA)

[/] [] [] [] []
 (ADD/DELETE)

* CIL RETENTION RATIONALE: (If applicable)

ADEQUATE []
 INADEQUATE []

REMARKS:

NO ISSUE. ONE POST 51L NASA FMEA ANALYZED THE FAILURE MODE RELATIVE TO FAILURE OF THE TOTAL INDICATION CIRCUIT SUCH THAT IT PROVIDED ERRONEOUS INDICATION. IOA FMEAs ANALYZED THE FAILURE MODE RELATIVE TO EACH INDIVIDUAL COMPONENTS IN THE CIRCUIT. IN CONSIDERATION THAT THE CRITICALITIES INVOLVED ARE ALL 3/3, THE FMEA DOES NOT REQUIRE ASSESSMENT. IOA RECOMMENDS COMBINING THE INDIVIDUAL IOA FMEAs.

APPENDIX C
ASSESSMENT WORKSHEET

ASSESSMENT DATE: 1/19/88
 ASSESSMENT ID: RMS-4144
 NASA FMEA #: 05-6IB-MPM-10

NASA DATA:
 BASELINE []
 NEW [X]

SUBSYSTEM: RMS/EPD&C
 MDAC ID: 4144
 ITEM: HYBRID DRIVERS, AR2, 4

LEAD ANALYST: ROBINSON

ASSESSMENT:

	CRITICALITY FLIGHT HDW/FUNC	REDUNDANCY SCREENS			CIL ITEM
		A	B	C	
NASA	[3 / 3]	[N]	[N]	[N]	[] *
IOA	[3 / 3]	[]	[]	[]	[]
COMPARE	[/]	[N]	[N]	[N]	[]

RECOMMENDATIONS: (If different from NASA)

[/] [] [] [] []
 (ADD/DELETE)

* CIL RETENTION RATIONALE: (If applicable)

ADEQUATE []
 INADEQUATE []

REMARKS:

NO ISSUE. ONE POST 51L NASA FMEA ANALYZED THE FAILURE MODE
 RELATIVE TO FAILURE OF THE TOTAL INDICATION CIRCUIT SUCH THAT IT
 PROVIDED ERRONEOUS INDICATION. IOA FMEAs ANALYZED THE FAILURE
 MODE RELATIVE TO EACH INDIVIDUAL COMPONENTS IN THE CIRCUIT.
 IN CONSIDERATION THAT THE CRITICALITIES INVOLVED ARE ALL 3/3, THE
 FMEA DOES NOT REQUIRE ASSESSMENT. IOA RECOMMENDS COMBINING THE
 INDIVIDUAL IOA FMEAs.

APPENDIX C
ASSESSMENT WORKSHEET

ASSESSMENT DATE: 1/19/88
 ASSESSMENT ID: RMS-4145
 NASA FMEA #: EPD&C 05-6-2616-1

NASA DATA:
 BASELINE [X]
 NEW []

SUBSYSTEM: RMS/EPD&C
 MDAC ID: 4145
 ITEM: CIRCUIT BREAKER, CB2

LEAD ANALYST: ROBINSON

ASSESSMENT:

	CRITICALITY FLIGHT HDW/FUNC	REDUNDANCY SCREENS			CIL ITEM
		A	B	C	
NASA	[/]	[]	[]	[]	[] *
IOA	[3 /2R]	[]	[NA]	[NA]	[]
COMPARE	[N /N]	[]	[N]	[N]	[]

RECOMMENDATIONS: (If different from NASA)

[/] [] [] [] []
 (ADD/DELETE)

* CIL RETENTION RATIONALE: (If applicable)

ADEQUATE []
 INADEQUATE []

REMARKS:

DISREGARD THIS IOA FMEA AND REFER TO IOA FMEA EPD&C-5968.
 THIS COMPONENT IS PART OF THE EPD&C PAYLOAD BAY MECHANICAL POWER
 SYSTEM AND SHOULD BE ANALYZED WITH REGARDS TO THE TOTAL EFFECTS
 OF THE FAILURE AND NOT LIMITED TO ITS EFFECTS ON RMS.

APPENDIX C
ASSESSMENT WORKSHEET

ASSESSMENT DATE: 1/19/88
 ASSESSMENT ID: RMS-4146
 NASA FMEA #: EPD&C 05-6-2616-2

NASA DATA:
 BASELINE [X]
 NEW []

SUBSYSTEM: RMS/EPD&C
 MDAC ID: 4146
 ITEM: CIRCUIT BREAKER, CB2

LEAD ANALYST: ROBINSON

ASSESSMENT:

	CRITICALITY FLIGHT HDW/FUNC	REDUNDANCY SCREENS			CIL ITEM
		A	B	C	
NASA	[/]	[]	[]	[]	[] *
IOA	[3 / 3]	[]	[]	[]	[]
COMPARE	[N / N]	[]	[]	[]	[]

RECOMMENDATIONS: (If different from NASA)

[/] [] [] [] []
 (ADD/DELETE)

* CIL RETENTION RATIONALE: (If applicable)

ADEQUATE []
 INADEQUATE []

REMARKS:

DISREGARD THIS IOA FMEA AND REFER TO IOA FMEA EPD&C-5969.
 THIS COMPONENT IS PART OF THE EPD&C PAYLOAD BAY MECHANICAL POWER
 SYSTEM AND SHOULD BE ANALYZED WITH REGARDS TO THE TOTAL EFFECTS
 OF THE FAILURE AND NOT LIMITED TO ITS EFFECTS ON RMS.

APPENDIX C
ASSESSMENT WORKSHEET

ASSESSMENT DATE: 1/19/88
 ASSESSMENT ID: RMS-4147
 NASA FMEA #: EPD&C 05-6-2615-1

NASA DATA:
 BASELINE [X]
 NEW []

SUBSYSTEM: RMS/EPD&C
 MDAC ID: 4147
 ITEM: CIRCUIT BREAKER, CB7

LEAD ANALYST: ROBINSON

ASSESSMENT:

	CRITICALITY FLIGHT HDW/FUNC	REDUNDANCY SCREENS			CIL ITEM
		A	B	C	
NASA	[/]	[]	[]	[]	[] *
IOA	[3 /2R]	[]	[NA]	[NA]	[]
COMPARE	[N /N]	[]	[N]	[N]	[]

RECOMMENDATIONS: (If different from NASA)

[/] [] [] [] []
 (ADD/DELETE)

* CIL RETENTION RATIONALE: (If applicable)

ADEQUATE []
 INADEQUATE []

REMARKS:

DISREGARD THIS IOA FMEA AND REFER TO IOA FMEA EPD&C-6148.
 THIS COMPONENT IS PART OF THE EPD&C PAYLOAD BAY MECHANICAL POWER
 SYSTEM AND SHOULD BE ANALYZED WITH REGARDS TO THE TOTAL EFFECTS
 OF THE FAILURE AND NOT LIMITED TO ITS EFFECTS ON RMS.

APPENDIX C
ASSESSMENT WORKSHEET

ASSESSMENT DATE: 1/19/88
 ASSESSMENT ID: RMS-4148
 NASA FMEA #: EPD&C 05-6-2615-2

NASA DATA:
 BASELINE [X]
 NEW []

SUBSYSTEM: RMS/EPD&C
 MDAC ID: 4148
 ITEM: CIRCUIT BREAKER, CB7

LEAD ANALYST: ROBINSON

ASSESSMENT:

	CRITICALITY FLIGHT HDW/FUNC	REDUNDANCY SCREENS			CIL ITEM
		A	B	C	
NASA	[/]	[]	[]	[]	[] *
IOA	[3 / 3]	[]	[]	[]	[]
COMPARE	[N / N]	[]	[]	[]	[]

RECOMMENDATIONS: (If different from NASA)

[/] [] [] [] []
 (ADD/DELETE)

* CIL RETENTION RATIONALE: (If applicable)

ADEQUATE []
 INADEQUATE []

REMARKS:

DISREGARD THIS IOA FMEA AND REFER TO IOA FMEA EPD&C-6149.
 THIS COMPONENT IS PART OF THE EPD&C PAYLOAD BAY MECHANICAL POWER
 SYSTEM AND SHOULD BE ANALYZED WITH REGARDS TO THE TOTAL EFFECTS
 OF THE FAILURE AND NOT LIMITED TO ITS EFFECTS ON RMS.

APPENDIX C
ASSESSMENT WORKSHEET

ASSESSMENT DATE: 1/19/88
 ASSESSMENT ID: RMS-4149
 NASA FMEA #: EPD&C 05-6-2615-1

NASA DATA:
 BASELINE [X]
 NEW []

SUBSYSTEM: RMS/EPD&C
 MDAC ID: 4149
 ITEM: CIRCUIT BREAKER, CB12

LEAD ANALYST: ROBINSON

ASSESSMENT:

	CRITICALITY FLIGHT HDW/FUNC	REDUNDANCY SCREENS			CIL ITEM
		A	B	C	
NASA	[/]	[]	[]	[]	[] *
IOA	[3 /2R]	[]	[NA]	[NA]	[]
COMPARE	[N /N]	[]	[N]	[N]	[]

RECOMMENDATIONS: (If different from NASA)

[/] [] [] [] []
 (ADD/DELETE)

* CIL RETENTION RATIONALE: (If applicable)

ADEQUATE []
 INADEQUATE []

REMARKS:

DISREGARD THIS IOA FMEA AND REFER TO IOA FMEA EPD&C-6330.
 THIS COMPONENT IS PART OF THE EPD&C PAYLOAD BAY MECHANICAL POWER
 SYSTEM AND SHOULD BE ANALYZED WITH REGARDS TO THE TOTAL EFFECTS
 OF THE FAILURE AND NOT LIMITED TO ITS EFFECTS ON RMS.

APPENDIX C
ASSESSMENT WORKSHEET

ASSESSMENT DATE: 1/19/88
 ASSESSMENT ID: RMS-4150
 NASA FMEA #: EPD&C 05-6-2615-2

NASA DATA:
 BASELINE [X]
 NEW []

SUBSYSTEM: RMS/EPD&C
 MDAC ID: 4150
 ITEM: CIRCUIT BREAKER, CB12

LEAD ANALYST: ROBINSON

ASSESSMENT:

	CRITICALITY FLIGHT HDW/FUNC	REDUNDANCY SCREENS			CIL ITEM
		A	B	C	
NASA	[/]	[]	[]	[]	[] *
IOA	[3 / 3]	[]	[]	[]	[]
COMPARE	[N / N]	[]	[]	[]	[]

RECOMMENDATIONS: (If different from NASA)

[/] [] [] [] []
 (ADD/DELETE)

* CIL RETENTION RATIONALE: (If applicable)

ADEQUATE []
 INADEQUATE []

REMARKS:

DISREGARD THIS IOA FMEA AND REFER TO IOA FMEA EPD&C-6331.
 THIS COMPONENT IS PART OF THE EPD&C PAYLOAD BAY MECHANICAL POWER
 SYSTEM AND SHOULD BE ANALYZED WITH REGARDS TO THE TOTAL EFFECTS
 OF THE FAILURE AND NOT LIMITED TO ITS EFFECTS ON RMS.

APPENDIX C
ASSESSMENT WORKSHEET

ASSESSMENT DATE: 1/19/88
 ASSESSMENT ID: RMS-4151
 NASA FMEA #: EPD&C 05-6-2614-1

NASA DATA:
 BASELINE [X]
 NEW []

SUBSYSTEM: RMS/EPD&C
 MDAC ID: 4151
 ITEM: CIRCUIT BREAKER, CB3

LEAD ANALYST: ROBINSON

ASSESSMENT:

	CRITICALITY FLIGHT HDW/FUNC	REDUNDANCY SCREENS			CIL ITEM
		A	B	C	
NASA	[/]	[]	[]	[]	[] *
IOA	[3 /2R]	[]	[NA]	[NA]	[]
COMPARE	[N /N]	[]	[N]	[N]	[]

RECOMMENDATIONS: (If different from NASA)

[/] [] [] [] []
 (ADD/DELETE)

* CIL RETENTION RATIONALE: (If applicable)

ADEQUATE []
 INADEQUATE []

REMARKS:

DISREGARD THIS IOA FMEA AND REFER TO IOA FMEA EPD&C-5970.
 THIS COMPONENT IS PART OF THE EPD&C PAYLOAD BAY MECHANICAL POWER
 SYSTEM AND SHOULD BE ANALYZED WITH REGARDS TO THE TOTAL EFFECTS
 OF THE FAILURE AND NOT LIMITED TO ITS EFFECTS ON RMS.

APPENDIX C
ASSESSMENT WORKSHEET

ASSESSMENT DATE: 1/19/88
 ASSESSMENT ID: RMS-4152
 NASA FMEA #: EPD&C 05-6-2614-2

NASA DATA:
 BASELINE [X]
 NEW []

SUBSYSTEM: RMS/EPD&C
 MDAC ID: 4152
 ITEM: CIRCUIT BREAKER, CB3

LEAD ANALYST: ROBINSON

ASSESSMENT:

	CRITICALITY FLIGHT HDW/FUNC	REDUNDANCY SCREENS			CIL ITEM
		A	B	C	
NASA	[/]	[]	[]	[]	[] *
IOA	[3 / 3]	[]	[]	[]	[]
COMPARE	[N / N]	[]	[]	[]	[]

RECOMMENDATIONS: (If different from NASA)

[/] [] [] [] []
 (ADD/DELETE)

* CIL RETENTION RATIONALE: (If applicable)

ADEQUATE []
 INADEQUATE []

REMARKS:

DISREGARD THIS IOA FMEA AND REFER TO IOA FMEA EPD&C-5971.
 THIS COMPONENT IS PART OF THE EPD&C PAYLOAD BAY MECHANICAL POWER
 SYSTEM AND SHOULD BE ANALYZED WITH REGARDS TO THE TOTAL EFFECTS
 OF THE FAILURE AND NOT LIMITED TO ITS EFFECTS ON RMS.

APPENDIX C
ASSESSMENT WORKSHEET

ASSESSMENT DATE: 1/19/88
 ASSESSMENT ID: RMS-4153
 NASA FMEA #: EPD&C 05-6-2613-1

NASA DATA:
 BASELINE [X]
 NEW []

SUBSYSTEM: RMS/EPD&C
 MDAC ID: 4153
 ITEM: CIRCUIT BREAKER, CB9

LEAD ANALYST: ROBINSON

ASSESSMENT:

	CRITICALITY FLIGHT HDW/FUNC	REDUNDANCY SCREENS			CIL ITEM
		A	B	C	
NASA	[/]	[]	[]	[]	[] *
IOA	[3 / 2R]	[]	[NA]	[NA]	[]
COMPARE	[N / N]	[]	[N]	[N]	[]

RECOMMENDATIONS: (If different from NASA)

[/] [] [] [] [] (ADD/DELETE)

* CIL RETENTION RATIONALE: (If applicable)

ADEQUATE []
 INADEQUATE []

REMARKS:

DISREGARD THIS IOA FMEA AND REFER TO IOA FMEA EPD&C-6152.
 THIS COMPONENT IS PART OF THE EPD&C PAYLOAD BAY MECHANICAL POWER
 SYSTEM AND SHOULD BE ANALYZED WITH REGARDS TO THE TOTAL EFFECTS
 OF THE FAILURE AND NOT LIMITED TO ITS EFFECTS ON RMS.

APPENDIX C
ASSESSMENT WORKSHEET

ASSESSMENT DATE: 1/19/88
 ASSESSMENT ID: RMS-4154
 NASA FMEA #: EPD&C 05-6-2613-2

NASA DATA:
 BASELINE [X]
 NEW []

SUBSYSTEM: RMS/EPD&C
 MDAC ID: 4154
 ITEM: CIRCUIT BREAKER, CB9

LEAD ANALYST: ROBINSON

ASSESSMENT:

	CRITICALITY FLIGHT HDW/FUNC	REDUNDANCY SCREENS			CIL ITEM
		A	B	C	
NASA	[/]	[]	[]	[]	[] *
IOA	[3 / 3]	[]	[]	[]	[]
COMPARE	[N / N]	[]	[]	[]	[]

RECOMMENDATIONS: (If different from NASA)

[/] [] [] [] []
 (ADD/DELETE)

* CIL RETENTION RATIONALE: (If applicable)

ADEQUATE []
 INADEQUATE []

REMARKS:

DISREGARD THIS IOA FMEA AND REFER TO IOA FMEA EPD&C-6153.
 THIS COMPONENT IS PART OF THE EPD&C PAYLOAD BAY MECHANICAL POWER
 SYSTEM AND SHOULD BE ANALYZED WITH REGARDS TO THE TOTAL EFFECTS
 OF THE FAILURE AND NOT LIMITED TO ITS EFFECTS ON RMS.

APPENDIX C
ASSESSMENT WORKSHEET

ASSESSMENT DATE: 1/19/88
 ASSESSMENT ID: RMS-4155
 NASA FMEA #: EPD&C 05-6-2613-1

NASA DATA:
 BASELINE [X]
 NEW []

SUBSYSTEM: RMS/EPD&C
 MDAC ID: 4155
 ITEM: CIRCUIT BREAKER, CB13

LEAD ANALYST: ROBINSON

ASSESSMENT:

	CRITICALITY FLIGHT HDW/FUNC	REDUNDANCY SCREENS			CIL ITEM
		A	B	C	
NASA	[/]	[]	[]	[]	[] *
IOA	[3 /2R]	[]	[NA]	[NA]	[]
COMPARE	[N /N]	[]	[N]	[N]	[]

RECOMMENDATIONS: (If different from NASA)

[/] [] [] [] []
 (ADD/DELETE)

* CIL RETENTION RATIONALE: (If applicable)

ADEQUATE []
 INADEQUATE []

REMARKS:

DISREGARD THIS IOA FMEA AND REFER TO IOA FMEA EPD&C-6332.
 THIS COMPONENT IS PART OF THE EPD&C PAYLOAD BAY MECHANICAL POWER
 SYSTEM AND SHOULD BE ANALYZED WITH REGARDS TO THE TOTAL EFFECTS
 OF THE FAILURE AND NOT LIMITED TO ITS EFFECTS ON RMS.

APPENDIX C
ASSESSMENT WORKSHEET

ASSESSMENT DATE: 1/19/88
 ASSESSMENT ID: RMS-4156
 NASA FMEA #: EPD&C 05-6-2613-2

NASA DATA:
 BASELINE [X]
 NEW []

SUBSYSTEM: RMS/EPD&C
 MDAC ID: 4156
 ITEM: CIRCUIT BREAKER, CB13

LEAD ANALYST: ROBINSON

ASSESSMENT:

	CRITICALITY FLIGHT HDW/FUNC	REDUNDANCY SCREENS			CIL ITEM
		A	B	C	
NASA	[/]	[]	[]	[]	[] *
IOA	[3 / 3]	[]	[]	[]	[]
COMPARE	[N / N]	[]	[]	[]	[]

RECOMMENDATIONS: (If different from NASA)

[/] [] [] [] []
 (ADD/DELETE)

* CIL RETENTION RATIONALE: (If applicable)

ADEQUATE []
 INADEQUATE []

REMARKS:

DISREGARD THIS IOA FMEA AND REFER TO IOA FMEA EPD&C-6333.
 THIS COMPONENT IS PART OF THE EPD&C PAYLOAD BAY MECHANICAL POWER
 SYSTEM AND SHOULD BE ANALYZED WITH REGARDS TO THE TOTAL EFFECTS
 OF THE FAILURE AND NOT LIMITED TO ITS EFFECTS ON RMS.

APPENDIX C
ASSESSMENT WORKSHEET

ASSESSMENT DATE: 1/19/88
 ASSESSMENT ID: RMS-4157
 NASA FMEA #: EPD&C 05-6-2653-2

NASA DATA:
 BASELINE [X]
 NEW []

SUBSYSTEM: RMS/EPD&C
 MDAC ID: 4157
 ITEM: SWITCH, S2

LEAD ANALYST: ROBINSON

ASSESSMENT:

	CRITICALITY FLIGHT HDW/FUNC	REDUNDANCY SCREENS			CIL ITEM
		A	B	C	
NASA	[/]	[]	[]	[]	[] *
IOA	[3 /2R]	[]	[NA]	[NA]	[]
COMPARE	[N /N]	[]	[N]	[N]	[]

RECOMMENDATIONS: (If different from NASA)

[/] [] [] [] []
 (ADD/DELETE)

* CIL RETENTION RATIONALE: (If applicable)

ADEQUATE []
 INADEQUATE []

REMARKS:

DISREGARD THIS IOA FMEA AND REFER TO IOA FMEA EPD&C-5083.
 THIS COMPONENT IS PART OF THE EPD&C PAYLOAD BAY MECHANICAL POWER
 SYSTEM AND SHOULD BE ANALYZED WITH REGARDS TO THE TOTAL EFFECTS
 OF THE FAILURE AND NOT LIMITED TO ITS EFFECTS ON RMS.

APPENDIX C
ASSESSMENT WORKSHEET

ASSESSMENT DATE: 1/19/88
 ASSESSMENT ID: RMS-4158
 NASA FMEA #: EPD&C 05-6-2656-1

NASA DATA:
 BASELINE [X]
 NEW []

SUBSYSTEM: RMS/EPD&C
 MDAC ID: 4158
 ITEM: SWITCH, S2

LEAD ANALYST: ROBINSON

ASSESSMENT:

	CRITICALITY FLIGHT HDW/FUNC	REDUNDANCY SCREENS			CIL ITEM
		A	B	C	
NASA	[/]	[]	[]	[]	[] *
IOA	[3 / 3]	[]	[]	[]	[]
COMPARE	[N / N]	[]	[]	[]	[]

RECOMMENDATIONS: (If different from NASA)

[/] [] [] [] []
 (ADD/DELETE)

* CIL RETENTION RATIONALE: (If applicable)

ADEQUATE []
 INADEQUATE []

REMARKS:

DISREGARD THIS IOA FMEA AND REFER TO IOA FMEA EPD&C-5084.
 THIS COMPONENT IS PART OF THE EPD&C PAYLOAD BAY MECHANICAL POWER
 SYSTEM AND SHOULD BE ANALYZED WITH REGARDS TO THE TOTAL EFFECTS
 OF THE FAILURE AND NOT LIMITED TO ITS EFFECTS ON RMS.

APPENDIX C
ASSESSMENT WORKSHEET

ASSESSMENT DATE: 1/19/88
 ASSESSMENT ID: RMS-4159
 NASA FMEA #: EPD&C 05-6-2653-1

NASA DATA:
 BASELINE [X]
 NEW []

SUBSYSTEM: RMS/EPD&C
 MDAC ID: 4159
 ITEM: SWITCH, S3

LEAD ANALYST: ROBINSON

ASSESSMENT:

	CRITICALITY FLIGHT HDW/FUNC	REDUNDANCY SCREENS			CIL ITEM
		A	B	C	
NASA	[/]	[]	[]	[]	*
IOA	[3 /2R]	[]	[NA]	[NA]	[]
COMPARE	[N /N]	[]	[N]	[N]	[]

RECOMMENDATIONS: (If different from NASA)

[/] [] [] [] []
 (ADD/DELETE)

* CIL RETENTION RATIONALE: (If applicable)

ADEQUATE []
 INADEQUATE []

REMARKS:

DISREGARD THIS IOA FMEA AND REFER TO IOA FMEA EPD&C-5115.
 THIS COMPONENT IS PART OF THE EPD&C PAYLOAD BAY MECHANICAL POWER
 SYSTEM AND SHOULD BE ANALYZED WITH REGARDS TO THE TOTAL EFFECTS
 OF THE FAILURE AND NOT LIMITED TO ITS EFFECTS ON RMS.

APPENDIX C
ASSESSMENT WORKSHEET

ASSESSMENT DATE: 1/19/88
 ASSESSMENT ID: RMS-4160
 NASA FMEA #: EPD&C 05-6-2654-1

NASA DATA:
 BASELINE [X]
 NEW []

SUBSYSTEM: RMS/EPD&C
 MDAC ID: 4160
 ITEM: SWITCH, S3

LEAD ANALYST: ROBINSON

ASSESSMENT:

	CRITICALITY	REDUNDANCY SCREENS			CIL ITEM
	FLIGHT HDW/FUNC	A	B	C	
NASA	[/]	[]	[]	[]	[] *
IOA	[3 / 3]	[]	[]	[]	[]
COMPARE	[N / N]	[]	[]	[]	[]

RECOMMENDATIONS: (If different from NASA)

[/] [] [] [] []
 (ADD/DELETE)

* CIL RETENTION RATIONALE: (If applicable)

ADEQUATE []
 INADEQUATE []

REMARKS:

DISREGARD THIS IOA FMEA AND REFER TO IOA FMEA EPD&C-5116.
 THIS COMPONENT IS PART OF THE PAYLOAD BAY MECHANICAL POWER SYSTEM
 AND SHOULD BE ANALYZED WITH REGARDS TO THE TOTAL EFFECTS OF THE
 FAILURE AND NOT LIMITED TO ITS EFFECTS ON RMS.

APPENDIX C
ASSESSMENT WORKSHEET

ASSESSMENT DATE: 1/19/88
 ASSESSMENT ID: RMS-4161
 NASA FMEA #: EPD&C 05-6-2653-2

NASA DATA:
 BASELINE [X]
 NEW []

SUBSYSTEM: RMS/EPD&C
 MDAC ID: 4161
 ITEM: SWITCH, S7

LEAD ANALYST: ROBINSON

ASSESSMENT:

	CRITICALITY FLIGHT HDW/FUNC	REDUNDANCY SCREENS			CIL ITEM
		A	B	C	
NASA	[/]	[]	[]	[]	[] *
IOA	[3 /2R]	[]	[NA]	[NA]	[]
COMPARE	[N /N]	[]	[N]	[N]	[]

RECOMMENDATIONS: (If different from NASA)

[/] [] [] [] []
 (ADD/DELETE)

* CIL RETENTION RATIONALE: (If applicable)

ADEQUATE []
 INADEQUATE []

REMARKS:

DISREGARD THIS IOA FMEA AND REFER TO IOA FMEA EPD&C-5224.
 THIS COMPONENT IS PART OF THE PAYLOAD BAY MECHANICAL POWER SYSTEM
 AND SHOULD BE ANALYZED WITH REGARDS TO THE TOTAL EFFECTS OF THE
 FAILURE AND NOT LIMITED TO ITS EFFECTS ON RMS.

APPENDIX C
ASSESSMENT WORKSHEET

ASSESSMENT DATE: 1/19/88
 ASSESSMENT ID: RMS-4162
 NASA FMEA #: EPD&C 05-6-2655-1

NASA DATA:
 BASELINE [X]
 NEW []

SUBSYSTEM: RMS/EPD&C
 MDAC ID: 4162
 ITEM: SWITCH, S7

LEAD ANALYST: ROBINSON

ASSESSMENT:

	CRITICALITY FLIGHT HDW/FUNC	REDUNDANCY SCREENS			CIL ITEM
		A	B	C	
NASA	[/]	[]	[]	[]	[] *
IOA	[3 / 3]	[]	[]	[]	[]
COMPARE	[N / N]	[]	[]	[]	[]

RECOMMENDATIONS: (If different from NASA)

[/] [] [] [] []
 (ADD/DELETE)

* CIL RETENTION RATIONALE: (If applicable)

ADEQUATE []
 INADEQUATE []

REMARKS:

DISREGARD THIS IOA FMEA AND REFER TO IOA FMEA EPD&C-5225.
 THIS COMPONENT IS PART OF THE PAYLOAD BAY MECHANICAL POWER SYSTEM
 AND SHOULD BE ANALYZED WITH REGARDS TO THE TOTAL EFFECTS OF THE
 FAILURE AND NOT LIMITED TO ITS EFFECTS ON RMS.

APPENDIX C
ASSESSMENT WORKSHEET

ASSESSMENT DATE: 1/19/88
 ASSESSMENT ID: RMS-4163
 NASA FMEA #: EPD&C 05-6-2653-2

NASA DATA:
 BASELINE [X]
 NEW []

SUBSYSTEM: RMS/EPD&C
 MDAC ID: 4163
 ITEM: SWITCH, S9

LEAD ANALYST: ROBINSON

ASSESSMENT:

	CRITICALITY FLIGHT HDW/FUNC	REDUNDANCY SCREENS			CIL ITEM
		A	B	C	
NASA	[/]	[]	[]	[]	[] *
IOA	[3 /2R]	[]	[NA]	[NA]	[]
COMPARE	[N /N]	[]	[N]	[N]	[]

RECOMMENDATIONS: (If different from NASA)

[/] [] [] [] [] (ADD/DELETE)

* CIL RETENTION RATIONALE: (If applicable)

ADEQUATE []
 INADEQUATE []

REMARKS:

DISREGARD THIS IOA FMEA AND REFER TO IOA FMEA EPD&C-5230.
 THIS COMPONENT IS PART OF THE PAYLOAD BAY MECHANICAL POWER SYSTEM
 AND SHOULD BE ANALYZED WITH REGARDS TO THE TOTAL EFFECTS OF THE
 FAILURE AND NOT LIMITED TO ITS EFFECTS ON RMS.

APPENDIX C
ASSESSMENT WORKSHEET

ASSESSMENT DATE: 1/19/88
 ASSESSMENT ID: RMS-4164
 NASA FMEA #: EPD&C 05-6-2655-1

NASA DATA:
 BASELINE [X]
 NEW []

SUBSYSTEM: RMS/EPD&C
 MDAC ID: 4164
 ITEM: SWITCH, S9

LEAD ANALYST: ROBINSON

ASSESSMENT:

	CRITICALITY FLIGHT HDW/FUNC	REDUNDANCY SCREENS			CIL ITEM
		A	B	C	
NASA	[/]	[]	[]	[]	[] *
IOA	[3 / 3]	[]	[]	[]	[]
COMPARE	[N / N]	[]	[]	[]	[]

RECOMMENDATIONS: (If different from NASA)

[/] [] [] [] []
 (ADD/DELETE)

* CIL RETENTION RATIONALE: (If applicable)

ADEQUATE []
 INADEQUATE []

REMARKS:
 DISREGARD THIS IOA FMEA AND REFER TO IOA FMEA EPD&C-5231.
 THIS COMPONENT IS PART OF THE PAYLOAD BAY MECHANICAL POWER SYSTEM
 AND SHOULD BE ANALIZED WITH REGARDS TO THE TOTAL EFFECTS OF THE
 FAILURE AND NOT LIMITED TO ITS EFFECTS ON RMS.

APPENDIX C
ASSESSMENT WORKSHEET

ASSESSMENT DATE: 1/19/88
 ASSESSMENT ID: RMS-4165
 NASA FMEA #: EPD&C 05-6-2653-2

NASA DATA:
 BASELINE [X]
 NEW []

SUBSYSTEM: RMS/EPD&C
 MDAC ID: 4165
 ITEM: SWITCH, S12

LEAD ANALYST: ROBINSON

ASSESSMENT:

	CRITICALITY FLIGHT HDW/FUNC	REDUNDANCY SCREENS			CIL ITEM
		A	B	C	
NASA	[/]	[]	[]	[]	[] *
IOA	[3 /2R]	[]	[NA]	[NA]	[]
COMPARE	[N /N]	[]	[N]	[N]	[]

RECOMMENDATIONS: (If different from NASA)

[/] [] [] [] []
 (ADD/DELETE)

* CIL RETENTION RATIONALE: (If applicable)

ADEQUATE []
 INADEQUATE []

REMARKS:

DISREGARD THIS IOA FMEA AND REFER TO IOA FMEA EPD&C-5432.
 THIS COMPONENT IS PART OF THE PAYLOAD BAY MECHANICAL POWER SYSTEM
 AND SHOULD BE ANALYZED WITH REGARDS TO THE TOTAL EFFECTS OF THE
 FAILURE AND NOT LIMITED TO ITS EFFECTS ON RMS.

APPENDIX C
ASSESSMENT WORKSHEET

ASSESSMENT DATE: 1/19/88
 ASSESSMENT ID: RMS-4166
 NASA FMEA #: EPD&C 05-6-2653-2

NASA DATA:
 BASELINE [X]
 NEW []

SUBSYSTEM: RMS/EPD&C
 MDAC ID: 4166
 ITEM: SWITCH, S12

LEAD ANALYST: ROBINSON

ASSESSMENT:

	CRITICALITY FLIGHT HDW/FUNC	REDUNDANCY SCREENS			CIL ITEM
		A	B	C	
NASA	[/]	[]	[]	[]	[] *
IOA	[3 / 3]	[]	[]	[]	[]
COMPARE	[N / N]	[]	[]	[]	[]

RECOMMENDATIONS: (If different from NASA)

[/] [] [] [] []
 (ADD/DELETE)

* CIL RETENTION RATIONALE: (If applicable)

ADEQUATE []
 INADEQUATE []

REMARKS:

DISREGARD THIS IOA FMEA AND REFER TO IOA FMEA EPD&C-5433.
 THIS COMPONENT IS PART OF THE PAYLOAD BAY MECHANICAL POWER SYSTEM
 AND SHOULD BE ANALYZED WITH REGARDS TO THE TOTAL EFFECTS OF THE
 FAILURE AND NOT LIMITED TO ITS EFFECTS ON RMS.

APPENDIX C
ASSESSMENT WORKSHEET

ASSESSMENT DATE: 1/19/88
 ASSESSMENT ID: RMS-4167
 NASA FMEA #: EPD&C 05-6-2653-1

NASA DATA:
 BASELINE [X]
 NEW []

SUBSYSTEM: RMS/EPD&C
 MDAC ID: 4167
 ITEM: SWITCH, S13

LEAD ANALYST: ROBINSON

ASSESSMENT:

	CRITICALITY FLIGHT HDW/FUNC	REDUNDANCY SCREENS			CIL ITEM
		A	B	C	
NASA	[/]	[]	[]	[]	[] *
IOA	[3 /2R]	[]	[NA]	[NA]	[]
COMPARE	[N /N]	[]	[N]	[N]	[]

RECOMMENDATIONS: (If different from NASA)

[/] [] [] [] []
 (ADD/DELETE)

* CIL RETENTION RATIONALE: (If applicable)

ADEQUATE []
 INADEQUATE []

REMARKS:

DISREGARD THIS IOA FMEA AND REFER TO IOA FMEA EPD&C-5434.
 THIS COMPONENT IS PART OF THE PAYLOAD BAY MECHANICAL POWER SYSTEM
 AND SHOULD BE ANALYZED WITH REGARDS TO THE TOTAL EFFECTS OF THE
 FAILURE AND NOT LIMITED TO ITS EFFECTS ON RMS.

APPENDIX C
ASSESSMENT WORKSHEET

ASSESSMENT DATE: 1/19/88
 ASSESSMENT ID: RMS-4168
 NASA FMEA #: EPD&C 05-6-2653-2

NASA DATA:
 BASELINE [X]
 NEW []

SUBSYSTEM: RMS/EPD&C
 MDAC ID: 4168
 ITEM: SWITCH, S13

LEAD ANALYST: ROBINSON

ASSESSMENT:

	CRITICALITY FLIGHT HDW/FUNC	REDUNDANCY SCREENS			CIL ITEM
		A	B	C	
NASA	[/]	[]	[]	[]	[] *
IOA	[3 / 3]	[]	[]	[]	[]
COMPARE	[N / N]	[]	[]	[]	[]

RECOMMENDATIONS: (If different from NASA)

[/] [] [] [] []
 (ADD/DELETE)

* CIL RETENTION RATIONALE: (If applicable)

ADEQUATE []
 INADEQUATE []

REMARKS:

DISREGARD THIS IOA FMEA AND REFER TO IOA FMEA EPD&C-5435.
 THIS COMPONENT IS PART OF THE PAYLOAD BAY MECHANICAL POWER SYSTEM
 AND SHOULD BE ANALYZED WITH REGARDS TO THE TOTAL EFFECTS OF THE
 FAILURE AND NOT LIMITED TO ITS EFFECTS ON RMS.

APPENDIX C
ASSESSMENT WORKSHEET

ASSESSMENT DATE: 1/19/88
 ASSESSMENT ID: RMS-4169
 NASA FMEA #: EPD&C 05-6-2706-1

NASA DATA:
 BASELINE [X]
 NEW []

SUBSYSTEM: RMS/EPD&C
 MDAC ID: 4169
 ITEM: RESISTOR, R2

LEAD ANALYST: ROBINSON

ASSESSMENT:

	CRITICALITY FLIGHT HDW/FUNC	REDUNDANCY SCREENS			CIL ITEM
		A	B	C	
NASA	[/]	[]	[]	[]	[] *
IOA	[3 /2R]	[]	[NA]	[NA]	[]
COMPARE	[N /N]	[]	[N]	[N]	[]

RECOMMENDATIONS: (If different from NASA)

[/] [] [] [] []
 (ADD/DELETE)

* CIL RETENTION RATIONALE: (If applicable)

ADEQUATE []
 INADEQUATE []

REMARKS:

DISREGARD THIS IOA FMEA AND REFER TO IOA FMEA EPD&C-5082.
 THIS COMPONENT IS PART OF THE PAYLOAD BAY MECHANICAL POWER SYSTEM
 AND SHOULD BE ANALYZED WITH REGARDS TO THE TOTAL EFFECTS OF THE
 FAILURE AND NOT LIMITED TO ITS EFFECTS ON RMS.

APPENDIX C
ASSESSMENT WORKSHEET

ASSESSMENT DATE: 1/19/88
 ASSESSMENT ID: RMS-4170
 NASA FMEA #: EPD&C 05-6-2704-1

NASA DATA:
 BASELINE [X]
 NEW []

SUBSYSTEM: RMS/EPD&C
 MDAC ID: 4170
 ITEM: RESISTOR, R3

LEAD ANALYST: ROBINSON

ASSESSMENT:

	CRITICALITY FLIGHT HDW/FUNC	REDUNDANCY SCREENS			CIL ITEM
		A	B	C	
NASA	[/]	[]	[]	[]	[] *
IOA	[3 /2R]	[]	[NA]	[NA]	[]
COMPARE	[N /N]	[]	[N]	[N]	[]

RECOMMENDATIONS: (If different from NASA)

[/] [] [] [] []
 (ADD/DELETE)

* CIL RETENTION RATIONALE: (If applicable)

ADEQUATE []
 INADEQUATE []

REMARKS:

DISREGARD THIS IOA FMEA AND REFER TO IOA FMEA EPD&C-5114.
 THIS COMPONENT IS PART OF THE PAYLOAD BAY MECHANICAL POWER SYSTEM
 AND SHOULD BE ANALYZED WITH REGARDS TO THE TOTAL EFFECTS OF THE
 FAILURE AND NOT LIMITED TO ITS EFFECTS ON RMS.

APPENDIX C
ASSESSMENT WORKSHEET

ASSESSMENT DATE: 1/19/88
 ASSESSMENT ID: RMS-4171
 NASA FMEA #: EPD&C 05-6-2705-1

NASA DATA:
 BASELINE [X]
 NEW []

SUBSYSTEM: RMS/EPD&C
 MDAC ID: 4171
 ITEM: RESISTOR, R7

LEAD ANALYST: ROBINSON

ASSESSMENT:

	CRITICALITY FLIGHT HDW/FUNC	REDUNDANCY SCREENS			CIL ITEM
		A	B	C	
NASA	[/]	[]	[]	[]	* []
IOA	[3 /2R]	[]	[NA]	[NA]	
COMPARE	[N /N]	[]	[N]	[N]	[]

RECOMMENDATIONS: (If different from NASA)

[/] [] [] [] []
 (ADD/DELETE)

* CIL RETENTION RATIONALE: (If applicable)

ADEQUATE []
 INADEQUATE []

REMARKS:

DISREGARD THIS IOA FMEA AND REFER TO IOA FMEA EPD&C-5223.
 THIS COMPONENT IS PART OF THE PAYLOAD BAY MECHANICAL POWER SYSTEM
 AND SHOULD BE ANALYZED WITH REGARDS TO THE TOTAL EFFECTS OF THE
 FAILURE AND NOT LIMITED TO ITS EFFECTS ON RMS.

APPENDIX C
ASSESSMENT WORKSHEET

ASSESSMENT DATE: 1/19/88
 ASSESSMENT ID: RMS-4172
 NASA FMEA #: EPD&C 05-6-2703-1

NASA DATA:
 BASELINE [X]
 NEW []

SUBSYSTEM: RMS/EPD&C
 MDAC ID: 4172
 ITEM: RESISTOR, R9

LEAD ANALYST: ROBINSON

ASSESSMENT:

	CRITICALITY FLIGHT HDW/FUNC	REDUNDANCY SCREENS			CIL ITEM
		A	B	C	
NASA	[/]	[]	[]	[]	[] *
IOA	[3 /2R]	[]	[NA]	[NA]	[]
COMPARE	[N /N]	[]	[N]	[N]	[]

RECOMMENDATIONS: (If different from NASA)

[/] [] [] [] []
 (ADD/DELETE)

* CIL RETENTION RATIONALE: (If applicable)

ADEQUATE []
 INADEQUATE []

REMARKS:

DISREGARD THIS IOA FMEA AND REFER TO IOA FMEA EPD&C-5229.
 THIS COMPONENT IS PART OF THE PAYLOAD BAY MECHANICAL POWER SYSTEM
 AND SHOULD BE ANALYZED WITH REGARDS TO THE TOTAL EFFECTS OF THE
 FAILURE AND NOT LIMITED TO ITS EFFECTS ON RMS.

APPENDIX C
ASSESSMENT WORKSHEET

ASSESSMENT DATE: 1/19/88
 ASSESSMENT ID: RMS-4173
 NASA FMEA #: EPD&C 05-6-2705-1

NASA DATA:
 BASELINE [X]
 NEW []

SUBSYSTEM: RMS/EPD&C
 MDAC ID: 4173
 ITEM: RESISTOR, R12

LEAD ANALYST: ROBINSON

ASSESSMENT:

	CRITICALITY FLIGHT HDW/FUNC	REDUNDANCY SCREENS			CIL ITEM
		A	B	C	
NASA	[/]	[]	[]	[]	[] *
IOA	[3 /2R]	[]	[NA]	[NA]	[]
COMPARE	[N /N]	[]	[N]	[N]	[]

RECOMMENDATIONS: (If different from NASA)

[/] [] [] [] []
 (ADD/DELETE)

* CIL RETENTION RATIONALE: (If applicable)

ADEQUATE []
 INADEQUATE []

REMARKS:

DISREGARD THIS IOA FMEA AND REFER TO IOA FMEA EPD&C-5439.
 THIS COMPONENT IS PART OF THE PAYLOAD BAY MECHANICAL POWER SYSTEM
 AND SHOULD BE ANALYZED WITH REGARDS TO THE TOTAL EFFECTS OF THE
 FAILURE AND NOT LIMITED TO ITS EFFECTS ON RMS.

APPENDIX C
ASSESSMENT WORKSHEET

ASSESSMENT DATE: 1/19/88
 ASSESSMENT ID: RMS-4174
 NASA FMEA #: EPD&C 05-6-2703-1

NASA DATA:
 BASELINE [X]
 NEW []

SUBSYSTEM: RMS/EPD&C
 MDAC ID: 4174
 ITEM: RESISTOR, R13

LEAD ANALYST: ROBINSON

ASSESSMENT:

	CRITICALITY FLIGHT HDW/FUNC	REDUNDANCY SCREENS			CIL ITEM
		A	B	C	
NASA	[/]	[]	[]	[]	[] *
IOA	[3 /2R]	[]	[NA]	[NA]	[]
COMPARE	[N /N]	[]	[N]	[N]	[]

RECOMMENDATIONS: (If different from NASA)

[/] [] [] [] [] (ADD/DELETE)

* CIL RETENTION RATIONALE: (If applicable)

ADEQUATE []
 INADEQUATE []

REMARKS:

DISREGARD THIS IOA FMEA AND REFER TO IOA FMEA EPD&C-5431.
 THIS COMPONENT IS PART OF THE PAYLOAD BAY MECHANICAL POWER SYSTEM
 AND SHOULD BE ANALYZED WITH REGARDS TO THE TOTAL EFFECTS OF THE
 FAILURE AND NOT LIMITED TO ITS EFFECTS ON RMS.

APPENDIX C
ASSESSMENT WORKSHEET

ASSESSMENT DATE: 1/15/88
 ASSESSMENT ID: RMS-4175X
 NASA FMEA #: 05-6IB-MPM-2C

NASA DATA:
 BASELINE []
 NEW [X]

SUBSYSTEM: RMS/EPD&C
 MDAC ID: 4175
 ITEM: SWITCH, S2

LEAD ANALYST: ROBINSON

ASSESSMENT:

	CRITICALITY FLIGHT HDW/FUNC	REDUNDANCY SCREENS			CIL ITEM
		A	B	C	
NASA	[3 / 3]	[P]	[P]	[P]	[] *
IOA	[3 / 3]	[]	[]	[]	[]
COMPARE	[/]	[N]	[N]	[N]	[]

RECOMMENDATIONS: (If different from NASA)

[/] [] [] [] []
 (ADD/DELETE)

* CIL RETENTION RATIONALE: (If applicable)

ADEQUATE []
 INADEQUATE []

REMARKS:

THIS FMEA DOES NOT REQUIRE ASSESSMENT DUE TO ITS CRIT. THIS IOA FMEA WAS GENERATED TO ESTABLISH A FAILURE MODE WHICH WAS NOT COVERED BY IOA IN THE ORIGINAL ANALYSIS.
 IOA CONCURS WITH THE NASA POST 51L FMEA EXCEPT THAT THE REDUNDANCY SCREENS SHOULD BE BLANK FOR CRIT 3/3 FMEAs.

APPENDIX C
ASSESSMENT WORKSHEET

ASSESSMENT DATE: 1/28/88
 ASSESSMENT ID: RMS-4176X
 NASA FMEA #: 05-61B-MPM-2F

NASA DATA:
 BASELINE []
 NEW [X]

SUBSYSTEM: RMS/EPD&C
 MDAC ID: 4176
 ITEM: SWITCH, S2

LEAD ANALYST: ROBINSON

ASSESSMENT:

	CRITICALITY FLIGHT HDW/FUNC	REDUNDANCY SCREENS			CIL ITEM
		A	B	C	
NASA	[2 /1R]	[P]	[P]	[P]	[X] *
IOA	[2 /1R]	[P]	[P]	[P]	[X]
COMPARE	[/]	[]	[]	[]	[]

RECOMMENDATIONS: (If different from NASA)

[/] [] [] [] [] (ADD/DELETE)

* CIL RETENTION RATIONALE: (If applicable)

ADEQUATE []
 INADEQUATE []

REMARKS:

IOA CONCURS WITH THE POST 51L NASA FMEA. THIS IOA FMEA WAS GENERATED TO ESTABLISH A FAILURE MODE WHICH WAS NOT COVERED BY IOA IN THE ORIGINAL ANALYSIS.

LOSS OF OPERATION OF THE STOW/DEPLOY ACTUATOR COULD CAUSE LOSS OF MISSION AND POSSIBLY REQUIRE JETTISON OF THE REMOTE MANIPULATOR ARM IF IT CANNOT BE SAFELY STOWED AND POSSIBLE LOSS OF CREW/VEHICLE IF IT CANNOT BE SAFELY JETTISONED.

APPENDIX C
ASSESSMENT WORKSHEET

ASSESSMENT DATE: 2/24/88
 ASSESSMENT ID: RMS-4177X
 NASA FMEA #: 05-6IB-MPM-5A

NASA DATA:
 BASELINE []
 NEW [X]

SUBSYSTEM: RMS/EPD&C
 MDAC ID: 4177
 ITEM: RESISTORS, 2W, (6 EACH)

LEAD ANALYST: ROBINSON

ASSESSMENT:

	CRITICALITY FLIGHT HDW/FUNC	REDUNDANCY SCREENS			CIL ITEM
		A	B	C	
NASA	[3 / 3]	[]	[]	[]	[] *
IOA	[3 / 3]	[]	[]	[]	[]
COMPARE	[/]	[]	[]	[]	[]

RECOMMENDATIONS: (If different from NASA)

[/] [] [] [] []
 (ADD/DELETE)

* CIL RETENTION RATIONALE: (If applicable)

ADEQUATE []
 INADEQUATE []

REMARKS:

NO ISSUE. IOA CONCURS WITH NASA POST 51L FMEA EXCEPT THAT THE REDUNDANCY SCREENS SHOULD BE BLANK. THIS IOA ADDITIONAL FMEA IS GENERATED FOR ASSESSMENT PURPOSES.

APPENDIX C
ASSESSMENT WORKSHEET

ASSESSMENT DATE: 2/24/88
 ASSESSMENT ID: RMS-4178X
 NASA FMEA #: 05-6IB-MPM-6

NASA DATA:
 BASELINE []
 NEW [X]

SUBSYSTEM: RMS/EPD&C
 MDAC ID: 4178
 ITEM: RESISTORS, 1.2 KOHM, 2W, (2 EACH)

LEAD ANALYST: ROBINSON

ASSESSMENT:

	CRITICALITY FLIGHT HDW/FUNC	REDUNDANCY SCREENS			CIL ITEM
		A	B	C	
NASA	[3 /1R]	[P]	[P]	[P]	[] *
IOA	[3 /1R]	[P]	[P]	[P]	[]
COMPARE	[/]	[]	[]	[]	[]

RECOMMENDATIONS: (If different from NASA)

[/] [] [] [] []
 (ADD/DELETE)

* CIL RETENTION RATIONALE: (If applicable)

ADEQUATE []
 INADEQUATE []

REMARKS:

NO ISSUE. IOA CONCURS WITH NASA POST 51L FMEA. THIS IOA
 ADDITIONAL FMEA IS GENERATED FOR ASSESSMENT PURPOSES.

APPENDIX C
ASSESSMENT WORKSHEET

ASSESSMENT DATE: 2/24/88
 ASSESSMENT ID: RMS-4179X
 NASA FMEA #: 05-6IB-MPM-7

NASA DATA:
 BASELINE []
 NEW [X]

SUBSYSTEM: RMS/EPD&C
 MDAC ID: 4179
 ITEM: LIMIT SWITCHES (2 EACH)

LEAD ANALYST: ROBINSON

ASSESSMENT:

	CRITICALITY FLIGHT HDW/FUNC	REDUNDANCY SCREENS			CIL ITEM
		A	B	C	
NASA	[3 /1R]	[P]	[P]	[P]	[] *
IOA	[3 /1R]	[P]	[P]	[P]	[]
COMPARE	[/]	[]	[]	[]	[]

RECOMMENDATIONS: (If different from NASA)

[/] [] [] [] []
 (ADD/DELETE)

* CIL RETENTION RATIONALE: (If applicable)

ADEQUATE []
 INADEQUATE []

REMARKS:

NO ISSUE. IOA CONCURS WITH NASA POST 51L FMEA. THIS IOA
 ADDITIONAL FMEA IS GENERATED FOR ASSESSMENT PURPOSES.

APPENDIX C
ASSESSMENT WORKSHEET

ASSESSMENT DATE: 2/24/88
 ASSESSMENT ID: RMS-4180X
 NASA FMEA #: 05-6IB-MPM-7A

NASA DATA:
 BASELINE []
 NEW [X]

SUBSYSTEM: RMS/EPD&C
 MDAC ID: 4180
 ITEM: LIMIT SWITCHES (2 EACH)

LEAD ANALYST: ROBINSON

ASSESSMENT:

	CRITICALITY FLIGHT HDW/FUNC	REDUNDANCY SCREENS			CIL ITEM
		A	B	C	
NASA	[3 /1R]	[P]	[P]	[P]	[] *
IOA	[3 /2R]	[P]	[P]	[P]	[]
COMPARE	[/N]	[]	[]	[]	[]

RECOMMENDATIONS: (If different from NASA)

[/] [] [] [] []
 (ADD/DELETE)

* CIL RETENTION RATIONALE: (If applicable)

ADEQUATE []
 INADEQUATE []

REMARKS:

NO ISSUE. IOA CONCURS WITH NASA POST 51L FMEA. THIS IOA
 ADDITIONAL FMEA IS GENERATED FOR ASSESSMENT PURPOSES.

APPENDIX C
ASSESSMENT WORKSHEET

ASSESSMENT DATE: 2/24/88
 ASSESSMENT ID: RMS-4181X
 NASA FMEA #: 05-6IB-MPM-8

NASA DATA:
 BASELINE []
 NEW [X]

SUBSYSTEM: RMS/EPD&C
 MDAC ID: 4181
 ITEM: LIMIT SWITCHES (2 EACH)

LEAD ANALYST: ROBINSON

ASSESSMENT:

	CRITICALITY FLIGHT HDW/FUNC	REDUNDANCY SCREENS			CIL ITEM
		A	B	C	
NASA	[3 /1R]	[P]	[P]	[P]	[] *
IOA	[3 /1R]	[P]	[P]	[P]	[]
COMPARE	[/]	[]	[]	[]	[]

RECOMMENDATIONS: (If different from NASA)

[/] [] [] [] []
 (ADD/DELETE)

* CIL RETENTION RATIONALE: (If applicable)

ADEQUATE []
 INADEQUATE []

REMARKS:

NO ISSUE. IOA CONCURS WITH NASA POST 51L FMEA. THIS IOA ADDITIONAL FMEA IS GENERATED FOR ASSESSMENT PURPOSES.

APPENDIX C
ASSESSMENT WORKSHEET

ASSESSMENT DATE: 2/24/88
 ASSESSMENT ID: RMS-4182X
 NASA FMEA #: 05-6IB-MPM-8A

NASA DATA:
 BASELINE []
 NEW [X]

SUBSYSTEM: RMS/EPD&C
 MDAC ID: 4182
 ITEM: LIMIT SWITCHES (2 EACH)

LEAD ANALYST: ROBINSON

ASSESSMENT:

	CRITICALITY FLIGHT HDW/FUNC	REDUNDANCY SCREENS			CIL ITEM
		A	B	C	
NASA	[3 /1R]	[P]	[P]	[P]	[] *
IOA	[3 /1R]	[P]	[P]	[P]	[]
COMPARE	[/]	[]	[]	[]	[]

RECOMMENDATIONS: (If different from NASA)

[/] [] [] [] []
 (ADD/DELETE)

* CIL RETENTION RATIONALE: (If applicable)

ADEQUATE []
 INADEQUATE []

REMARKS:

NO ISSUE. IOA CONCURS WITH NASA POST 51L FMEA. THIS IOA
 ADDITIONAL FMEA IS GENERATED FOR ASSESSMENT PURPOSES.

APPENDIX C
ASSESSMENT WORKSHEET

ASSESSMENT DATE: 1/19/88
 ASSESSMENT ID: RMS-4183X
 NASA FMEA #: 05-6IB-MPM-11

NASA DATA:
 BASELINE []
 NEW [X]

SUBSYSTEM: RMS/EPD&C
 MDAC ID: 4183
 ITEM: RESISTORS, (16 EACH)

LEAD ANALYST: ROBINSON

ASSESSMENT:

	CRITICALITY FLIGHT HDW/FUNC	REDUNDANCY SCREENS			CIL ITEM
		A	B	C	
NASA	[3 / 3]	[N]	[N]	[N]	[] *
IOA	[3 / 3]	[]	[]	[]	[]
COMPARE	[/]	[N]	[N]	[N]	[]

RECOMMENDATIONS: (If different from NASA)

[/] [] [] [] [] (ADD/DELETE)

* CIL RETENTION RATIONALE: (If applicable)

ADEQUATE []
 INADEQUATE []

REMARKS:

NO ISSUE. THE FAILURE RESULTS IN LOSS OF POSITION INDICATIONS.
 IN CONSIDERATION THAT THE CRITICALITY INVOLVED IS 3/3, IOA
 RECOMMENDS GENERATING A COMPARABLE FMEA FOR ASSESSMENT
 SIMPLIFICATION.

APPENDIX C
ASSESSMENT WORKSHEET

ASSESSMENT DATE: 1/24/88
 ASSESSMENT ID: RMS-4201
 NASA FMEA #: 05-6IC-MRL-4

NASA DATA:
 BASELINE []
 NEW [X]

SUBSYSTEM: RMS/EPD&C
 MDAC ID: 4201
 ITEM: HYBRID RELAY, K20

LEAD ANALYST: ROBINSON

ASSESSMENT:

	CRITICALITY FLIGHT HDW/FUNC	REDUNDANCY SCREENS			CIL ITEM
		A	B	C	
NASA	[3 /1R]	[P]	[P]	[P]	[] *
IOA	[3 /2R]	[]	[NA]	[NA]	[]
COMPARE	[/N]	[N]	[N]	[N]	[]

RECOMMENDATIONS: (If different from NASA)

[/] [] [] [] []
 (ADD/DELETE)

* CIL RETENTION RATIONALE: (If applicable)

ADEQUATE []
 INADEQUATE []

REMARKS:

NO ISSUE.

IOA CONCURS WITH THE POST 51L CRIT OF 3/1R. IOA SCREENS SHOULD BE 1-P-P. TO COMPARE WITH THE NASA FMEA, IOA RECOMMENDS COMBINING THE FOLLOWING 24 IOA FMEAs: 4201, 4203, 4205, 4207, 4235, 4237, 4239, 4241, 4257, 4259, 4261, 4263, 4279, 4281, 4283, 4285, 4301, 4303, 4305, 4307, 4323, 4325, 4327, AND 4329. THE IOA FMEAs ARE FOR 12 PORT AND 12 STARBOARD HYBRID RELAYS USED BY SYSTEM 1 AND SYSTEM 2, FWD, MID, AND AFT LATCH/RELEASE FOR BOTH PORT AND STARBOARD ARMS.

APPENDIX C
ASSESSMENT WORKSHEET

ASSESSMENT DATE: 1/30/88
 ASSESSMENT ID: RMS-4202
 NASA FMEA #: 05-6IC-MRL-5

NASA DATA:
 BASELINE []
 NEW [X]

SUBSYSTEM: RMS/EPD&C
 MDAC ID: 4202
 ITEM: HYBRID RELAY, K20

LEAD ANALYST: ROBINSON

ASSESSMENT:

	CRITICALITY FLIGHT HDW/FUNC	REDUNDANCY SCREENS			CIL ITEM
		A	B	C	
NASA	[3 /1R]	[P]	[P]	[P]	[] *
IOA	[3 /2R]	[]	[NA]	[NA]	[]
COMPARE	[/N]	[N]	[N]	[N]	[]

RECOMMENDATIONS: (If different from NASA)

[/] [] [] [] []
 (ADD/DELETE)

* CIL RETENTION RATIONALE: (If applicable)

ADEQUATE []
 INADEQUATE []

REMARKS:

NO ISSUE.

IOA CONCURS WITH THE POST 51L CRIT OF 3/1R. IOA SCREENS SHOULD BE 1-P-P. TO COMPARE WITH THE NASA FMEA, IOA RECOMMENDS COMBINING THE FOLLOWING 12 IOA FMEAs: 4202, 4204, 4236, 4238, 4258, 4260, 4280, 4282, 4302, 4304, 4324, AND 4326. THE 12 IOA FMEAs ARE FOR 6 INDIVIDUAL PORT AND 6 INDIVIDUAL STARBOARD HYBRID RELAYS FOR LATCHING.

APPENDIX C
ASSESSMENT WORKSHEET

ASSESSMENT DATE: 1/24/88
 ASSESSMENT ID: RMS-4203
 NASA FMEA #: 05-6IC-MRL-4

NASA DATA:
 BASELINE []
 NEW [X]

SUBSYSTEM: RMS/EPD&C
 MDAC ID: 4203
 ITEM: HYBRID RELAY, K52

LEAD ANALYST: ROBINSON

ASSESSMENT:

	CRITICALITY FLIGHT HDW/FUNC	REDUNDANCY SCREENS			CIL ITEM
		A	B	C	
NASA	[3 /1R]	[P]	[P]	[P]	[] *
IOA	[3 /2R]	[]	[NA]	[NA]	[]
COMPARE	[/N]	[N]	[N]	[N]	[]

RECOMMENDATIONS: (If different from NASA)

[/] [] [] [] []
 (ADD/DELETE)

* CIL RETENTION RATIONALE: (If applicable)

ADEQUATE []
 INADEQUATE []

REMARKS:

NO ISSUE.
 IOA CONCURS WITH THE POST 51L CRIT OF 3/1R. IOA SCREENS SHOULD BE 1-P-P. TO COMPARE WITH THE NASA FMEA, IOA RECOMMENDS COMBINING THE FOLLOWING 24 IOA FMEAs: 4201, 4203, 4205, 4207, 4235, 4237, 4239, 4241, 4257, 4259, 4261, 4263, 4279, 4281, 4283, 4285, 4301, 4303, 4305, 4307, 4323, 4325, 4327, AND 4329. THE IOA FMEAs ARE FOR 12 PORT AND 12 STARBOARD HYBRID RELAYS USED BY SYSTEM 1 AND SYSTEM 2, FWD, MID, AND AFT LATCH/RELEASE FOR BOTH PORT AND STARBOARD ARMS.

APPENDIX C
ASSESSMENT WORKSHEET

ASSESSMENT DATE: 1/30/88
 ASSESSMENT ID: RMS-4204
 NASA FMEA #: 05-6IC-MRL-5

NASA DATA:
 BASELINE []
 NEW [X]

SUBSYSTEM: RMS/EPD&C
 MDAC ID: 4204
 ITEM: HYBRID RELAY, K52

LEAD ANALYST: ROBINSON

ASSESSMENT:

	CRITICALITY FLIGHT HDW/FUNC	REDUNDANCY SCREENS			CIL ITEM
		A	B	C	
NASA	[3 /1R]	[P]	[P]	[P]	[] *
IOA	[3 /2R]	[]	[NA]	[NA]	[]
COMPARE	[/N]	[N]	[N]	[N]	[]

RECOMMENDATIONS: (If different from NASA)

[/] [] [] [] []
 (ADD/DELETE)

* CIL RETENTION RATIONALE: (If applicable)

ADEQUATE []
 INADEQUATE []

REMARKS:

NO ISSUE.

IOA CONCURS WITH THE POST 51L CRIT OF 3/1R. IOA SCREENS SHOULD BE 1-P-P. TO COMPARE WITH THE NASA FMEA, IOA RECOMMENDS COMBINING THE FOLLOWING 12 IOA FMEAs: 4202, 4204, 4236, 4238, 4258, 4260, 4280, 4282, 4302, 4304, 4324, AND 4326. THE 12 IOA FMEAs ARE FOR 6 INDIVIDUAL PORT AND 6 INDIVIDUAL STARBOARD HYBRID RELAYS FOR LATCHING.

APPENDIX C
ASSESSMENT WORKSHEET

ASSESSMENT DATE: 1/24/88
 ASSESSMENT ID: RMS-4205
 NASA FMEA #: 05-6IC-MRL-4

NASA DATA:
 BASELINE []
 NEW [X]

SUBSYSTEM: RMS/EPD&C
 MDAC ID: 4205
 ITEM: HYBRID RELAY, K8

LEAD ANALYST: ROBINSON

ASSESSMENT:

	CRITICALITY FLIGHT HDW/FUNC	REDUNDANCY SCREENS			CIL ITEM
		A	B	C	
NASA	[3 /1R]	[P]	[P]	[P]	[] *
IOA	[3 /2R]	[]	[NA]	[NA]	[]
COMPARE	[/N]	[N]	[N]	[N]	[]

RECOMMENDATIONS: (If different from NASA)

[/] [] [] [] []
 (ADD/DELETE)

* CIL RETENTION RATIONALE: (If applicable)

ADEQUATE []
 INADEQUATE []

REMARKS:

NO ISSUE.
 IOA CONCURS WITH THE POST 51L CRIT OF 3/1R. IOA SCREENS SHOULD BE 1-P-P. TO COMPARE WITH THE NASA FMEA, IOA RECOMMENDS COMBINING THE FOLLOWING 24 IOA FMEAs: 4201, 4203, 4205, 4207, 4235, 4237, 4239, 4241, 4257, 4259, 4261, 4263, 4279, 4281, 4283, 4285, 4301, 4303, 4305, 4307, 4323, 4325, 4327, AND 4329. THE IOA FMEAs ARE FOR 12 PORT AND 12 STARBOARD HYBRID RELAYS USED BY SYSTEM 1 AND SYSTEM 2, FWD, MID, AND AFT LATCH/RELEASE FOR BOTH PORT AND STARBOARD ARMS.

APPENDIX C
ASSESSMENT WORKSHEET

ASSESSMENT DATE: 2/16/88
 ASSESSMENT ID: RMS-4206
 NASA FMEA #: 05-6IC-MRL-6

NASA DATA:
 BASELINE []
 NEW [X]

SUBSYSTEM: RMS/EPD&C
 MDAC ID: 4206
 ITEM: HYBRID RELAY, K8

LEAD ANALYST: ROBINSON

ASSESSMENT:

	CRITICALITY FLIGHT HDW/FUNC	REDUNDANCY SCREENS			CIL ITEM
		A	B	C	
NASA	[2 /1R]	[P]	[F]	[P]	[X] *
IOA	[3 /2R]	[]	[NA]	[NA]	[]
COMPARE	[N /N]	[N]	[N]	[N]	[N]

RECOMMENDATIONS: (If different from NASA)

[/] [] [] [] []
 (ADD/DELETE)

* CIL RETENTION RATIONALE: (If applicable)

ADEQUATE []
 INADEQUATE []

REMARKS:

NO ISSUE.

IOA CONCURS WITH THE POST 51L CRIT OF 3/1R. IOA SCREENS SHOULD BE 1-P-P. TO COMPARE WITH THE NASA FMEA IOA RECOMMENDS COMBINING THE FOLLOWING 12 IOA FMEAs: 4206, 4208, 4240, 4242, 4262, 4264, 4284, 4286, 4306, 4308, 4328, AND 4330. THE 12 IOA FMEAs ARE FOR 6 INDIVIDUAL PORT AND 6 INDIVIDUAL STARBOARD HYBRID RELAYS FOR RELEASING.

APPENDIX C
ASSESSMENT WORKSHEET

ASSESSMENT DATE: 1/24/88
 ASSESSMENT ID: RMS-4207
 NASA FMEA #: 05-6IC-MRL-4

NASA DATA:
 BASELINE []
 NEW [X]

SUBSYSTEM: RMS/EPD&C
 MDAC ID: 4207
 ITEM: HYBRID RELAY, K64

LEAD ANALYST: ROBINSON

ASSESSMENT:

	CRITICALITY FLIGHT HDW/FUNC	REDUNDANCY SCREENS			CIL ITEM
		A	B	C	
NASA	[3 /1R]	[P]	[P]	[P]	[] *
IOA	[3 /2R]	[]	[NA]	[NA]	[]
COMPARE	[/N]	[N]	[N]	[N]	[]

RECOMMENDATIONS: (If different from NASA)

[/] [] [] [] []
 (ADD/DELETE)

* CIL RETENTION RATIONALE: (If applicable)

ADEQUATE []
 INADEQUATE []

REMARKS:

NO ISSUE.
 IOA CONCURS WITH THE POST 51L CRIT OF 3/1R. IOA SCREENS SHOULD BE 1-P-P. TO COMPARE WITH THE NASA FMEA, IOA RECOMMENDS COMBINING THE FOLLOWING 24 IOA FMEAs: 4201, 4203, 4205, 4207, 4235, 4237, 4239, 4241, 4257, 4259, 4261, 4263, 4279, 4281, 4283, 4285, 4301, 4303, 4305, 4307, 4323, 4325, 4327, AND 4329. THE IOA FMEAs ARE FOR 12 PORT AND 12 STARBOARD HYBRID RELAYS USED BY SYSTEM 1 AND SYSTEM 2, FWD, MID, AND AFT LATCH/RELEASE FOR BOTH PORT AND STARBOARD ARMS.

APPENDIX C
ASSESSMENT WORKSHEET

ASSESSMENT DATE: 2/16/88	NASA DATA:
ASSESSMENT ID: RMS-4208	BASELINE []
NASA FMEA #: 05-6IC-MRL-6	NEW [X]

SUBSYSTEM: RMS/EPD&C
MDAC ID: 4208
ITEM: HYBRID RELAY, K64

LEAD ANALYST: ROBINSON

ASSESSMENT:

	CRITICALITY FLIGHT HDW/FUNC	REDUNDANCY SCREENS			CIL ITEM
		A	B	C	
NASA	[2 /1R]	[P]	[F]	[P]	[X] *
IOA	[3 /2R]	[]	[NA]	[NA]	[]
COMPARE	[N /N]	[N]	[N]	[N]	[N]

RECOMMENDATIONS: (If different from NASA)

[/] [] [] [] []
(ADD/DELETE)

* CIL RETENTION RATIONALE: (If applicable)

ADEQUATE []
INADEQUATE []

REMARKS:

NO ISSUE.

IOA CONCURS WITH THE POST 51L CRIT OF 3/1R. IOA SCREENS SHOULD BE 1-P-P. IOA RECOMMENDS COMBINING THE FOLLOWING IOA FEMAs TO COMPARE WITH THE NASA FMEA. COMBINE THE FOLLOWING 6 IOA FMEAs ARE FOR 6 PORT AND 6 STBD HYBRID RELAYS. THE 12 IOA FMEAs ARE FOR 6 INDIVIDUAL PORT AND 6 INDIVIDUAL STARBOARD HYBRID RELAYS FOR RELEASING.

APPENDIX C
ASSESSMENT WORKSHEET

ASSESSMENT DATE: 2/14/88
 ASSESSMENT ID: RMS-4209
 NASA FMEA #: 05-6ID-2128-1

NASA DATA:
 BASELINE []
 NEW [X]

SUBSYSTEM: RMS/EPD&C
 MDAC ID: 4209
 ITEM: RELAY, K44

LEAD ANALYST: ROBINSON

ASSESSMENT:

	CRITICALITY FLIGHT HDW/FUNC	REDUNDANCY SCREENS			CIL ITEM
		A	B	C	
NASA	[2 /1R]	[P]	[P]	[P]	[X] *
IOA	[3 /2R]	[]	[NA]	[NA]	[]
COMPARE	[N /N]	[N]	[N]	[N]	[N]

RECOMMENDATIONS: (If different from NASA)

[/] [] [] [P] []
 (ADD/DELETE)

* CIL RETENTION RATIONALE: (If applicable)

ADEQUATE []
 INADEQUATE []

REMARKS:

NO ISSUE. RECOMMEND UPGRADING IOA FMEA TO CRITICALITY 2/1R.
 THE IOA FMEA FOR FAILURE OF THESE RELAYS WAS GENERATED AS PART OF
 THE MANIPULATOR RETENTION LATCH CONTROL CIRCUIT WHICH IS 05-6IC
 SET OF NASA FMEAS ALSO AND THEREFORE THE RESULT OF THE FAILURES
 DO NOT MATCH WHEN COMPARED. THE RELAYS ARE 4 POLE, 2
 POSITION LATCHING RELAYS AND APPEAR IN BOTH THE LATCH CONTROL AND
 THE JETTISON/GUILLOTINE CIRCUITS. IOA CONCURS WITH THE NASA
 FAILURE.

APPENDIX C
ASSESSMENT WORKSHEET

ASSESSMENT DATE: 2/14/88
 ASSESSMENT ID: RMS-4210
 NASA FMEA #: 05-6ID-2131-1

NASA DATA:
 BASELINE [X]
 NEW []

SUBSYSTEM: RMS/EPD&C
 MDAC ID: 4210
 ITEM: RELAY, K76

LEAD ANALYST: ROBINSON

ASSESSMENT:

	CRITICALITY FLIGHT HDW/FUNC	REDUNDANCY SCREENS			CIL ITEM
		A	B	C	
NASA	[3 /3]	[P]	[P]	[P]	[] *
IOA	[3 /2R]	[P]	[NA]	[NA]	[]
COMPARE	[/N]	[]	[N]	[N]	[]

RECOMMENDATIONS: (If different from NASA)

[3 /2R] [] [] [P] []
 (ADD/DELETE)

* CIL RETENTION RATIONALE: (If applicable)

ADEQUATE []
 INADEQUATE []

REMARKS:

RECOMMEND UPGRADING THE NASA FMEA TO 3/2R. RECOMMEND COMBINING COMPONENTS IN IOA FMEAs 4210 AND 4288. THE IOA FMEA FOR FAILURE OF THESE RELAYS WAS GENERATED AS PART OF THE MANIPULATOR RETENTION LATCH CONTROL CIRCUIT WHICH IS 05-6I SET OF NASA FMEAS ALSO AND THEREFORE THE RESULT OF THE FAILURES DO NOT MATCH WHEN COMPARED. THE RELAYS ARE 4 POLE, 2 POSITION LATCHING RELAYS AND APPEAR IN BOTH THE LATCH CONTROL AND THE JETTISON/GUILLOTINE CIRCUITS. IOA CONCURS WITH THE NASA FAILURE.

APPENDIX C
ASSESSMENT WORKSHEET

ASSESSMENT DATE: 1/30/88
 ASSESSMENT ID: RMS-4211
 NASA FMEA #: 05-6IC-MRL-7A

NASA DATA:
 BASELINE []
 NEW [X]

SUBSYSTEM: RMS/EPD&C
 MDAC ID: 4211
 ITEM: FUSE, F4

LEAD ANALYST: ROBINSON

ASSESSMENT:

	CRITICALITY FLIGHT HDW/FUNC	REDUNDANCY SCREENS			CIL ITEM
		A	B	C	
NASA	[3 /1R]	[P]	[P]	[P]	[] *
IOA	[3 /3]	[]	[]	[]	[]
COMPARE	[/N]	[N]	[N]	[N]	[]

RECOMMENDATIONS: (If different from NASA)

[/] [] [] [] []
 (ADD/DELETE)

* CIL RETENTION RATIONALE: (If applicable)

ADEQUATE []
 INADEQUATE []

REMARKS:

UPGRADE IOA CRIT TO 3/1R AND CORRECT IOA SCREENS. SUBSEQUENT MULTIPLE FAILURES COULD CAUSE MOTOR BURNOUT AND COULD LEAD TO INABILITY TO SAFELY LATCH THE RMS AND SUBSEQUENT FAILURE OF THE GUILLOTINE/JETTISON SYSTEM COULD RESULT IN LOSS OF CREW/VEHICLE. THIS ONE NASA FMEA CORRESPONDS TO THE FOLLOWING IOA FMEAs: 4211, 4212, 4245, 4246, 4267, 4268, 4289, 4290, 4311, 4312, 4333, AND 4334. IOA RECOMMENDS COMBINING ALL LISTED IOA FMEAs INTO ONE TO ALLOW COMPARISON WITH THE NASA POST 51L FMEA.

APPENDIX C
ASSESSMENT WORKSHEET

ASSESSMENT DATE: 1/30/88
 ASSESSMENT ID: RMS-4212
 NASA FMEA #: 05-6IC-MRL-7A

NASA DATA:
 BASELINE []
 NEW [X]

SUBSYSTEM: RMS/EPD&C
 MDAC ID: 4212
 ITEM: FUSE, F6

LEAD ANALYST: ROBINSON

ASSESSMENT:

	CRITICALITY FLIGHT HDW/FUNC	REDUNDANCY SCREENS			CIL ITEM
		A	B	C	
NASA	[3 /1R]	[P]	[P]	[P]	[] *
IOA	[3 /3]	[]	[]	[]	[]
COMPARE	[/N]	[N]	[N]	[N]	[]

RECOMMENDATIONS: (If different from NASA)

[/] [] [] [] []
 (ADD/DELETE)

* CIL RETENTION RATIONALE: (If applicable)

ADEQUATE []
 INADEQUATE []

REMARKS:

UPGRADE IOA CRIT TO 3/1R AND CORRECT IOA SCREENS. SUBSEQUENT MULTIPLE FAILURES COULD CAUSE MOTOR BURNOUT AND COULD LEAD TO INABILITY TO SAFELY LATCH THE RMS AND SUBSEQUENT FAILURE OF THE GUILLOTINE/JETTISON SYSTEM COULD RESULT IN LOSS OF CREW/VEHICLE. THIS ONE NASA FMEA CORRESPONDS TO THE FOLLOWING IOA FMEAs: 4211, 4212, 4245, 4246, 4267, 4268, 4289, 4290, 4311, 4312, 4333, AND 4334. IOA RECOMMENDS COMBINING ALL LISTED IOA FMEAs INTO ONE TO ALLOW COMPARISON WITH THE NASA POST 51L FMEA.

C-3

APPENDIX C
ASSESSMENT WORKSHEET

ASSESSMENT DATE: 1/25/88
 ASSESSMENT ID: RMS-4213
 NASA FMEA #: 05-6IC-MRL-12

NASA DATA:
 BASELINE []
 NEW [X]

SUBSYSTEM: RMS/EPD&C
 MDAC ID: 4213
 ITEM: RESISTOR, R27

LEAD ANALYST: ROBINSON

ASSESSMENT:

	CRITICALITY FLIGHT HDW/FUNC	REDUNDANCY SCREENS			CIL ITEM
		A	B	C	
NASA	[3 / 3]	[N]	[N]	[N]	[] *
IOA	[3 / 3]	[]	[]	[]	[]
COMPARE	[/]	[N]	[N]	[N]	[]

RECOMMENDATIONS: (If different from NASA)

[/] [] [] [] []
 (ADD/DELETE)

* CIL RETENTION RATIONALE: (If applicable)

ADEQUATE []
 INADEQUATE []

REMARKS:

NO ISSUE. THE NASA FMEA ITEM IS THE "READY TO LATCH INDICATION CIRCUIT" WITH THE FAILURE MODE AS "ERRONEOUS INDICATION". THE IOA FMEAs ADDRESS THE INDIVIDUAL COMPONENTS. FOR COMPARISON PURPOSES, IOA RECOMMENDS COMBINING THE FOLLOWING IOA FMEAs: 4213 THRU 4216, 4247 THRU 4750, 4269 THRU 4272, 4291 THRU 4294, 4313 THRU 4316, AND 4335 THRU 4338.

APPENDIX C
ASSESSMENT WORKSHEET

ASSESSMENT DATE: 1/25/88
 ASSESSMENT ID: RMS-4214
 NASA FMEA #: 05-6IC-MRL-12

NASA DATA:
 BASELINE []
 NEW [X]

SUBSYSTEM: RMS/EPD&C
 MDAC ID: 4214
 ITEM: RESISTOR, R67

LEAD ANALYST: ROBINSON

ASSESSMENT:

	CRITICALITY FLIGHT HDW/FUNC	REDUNDANCY SCREENS			CIL ITEM
		A	B	C	
NASA	[3 / 3]	[N]	[N]	[N]	[] *
IOA	[3 / 3]	[]	[]	[]	[]
COMPARE	[/]	[N]	[N]	[N]	[]

RECOMMENDATIONS: (If different from NASA)

[/] [] [] [] []
 (ADD/DELETE)

* CIL RETENTION RATIONALE: (If applicable)

ADEQUATE []
 INADEQUATE []

REMARKS:

NO ISSUE. THE NASA FMEA ITEM IS THE "READY TO LATCH INDICATION CIRCUIT" WITH THE FAILURE MODE AS "ERRONEOUS INDICATION". THE IOA FMEAs ADDRESS THE INDIVIDUAL COMPONENTS. FOR COMPARISON PURPOSES, IOA RECOMMENDS COMBINING THE FOLLOWING IOA FMEAs: 4213 THRU 4216, 4247 THRU 4750, 4269 THRU 4272, 4291 THRU 4294, 4313 THRU 4316, AND 4335 THRU 4338.

APPENDIX C
ASSESSMENT WORKSHEET

ASSESSMENT DATE: 1/25/88
 ASSESSMENT ID: RMS-4215
 NASA FMEA #: 05-6IC-MRL-12

NASA DATA:
 BASELINE []
 NEW [X]

SUBSYSTEM: RMS/EPD&C
 MDAC ID: 4215
 ITEM: RESISTOR, R28

LEAD ANALYST: ROBINSON

ASSESSMENT:

	CRITICALITY FLIGHT HDW/FUNC	REDUNDANCY SCREENS			CIL ITEM
		A	B	C	
NASA	[3 / 3]	[N]	[N]	[N]	[] *
IOA	[3 / 3]	[]	[]	[]	[]
COMPARE	[/]	[N]	[N]	[N]	[]

RECOMMENDATIONS: (If different from NASA)

[/] [] [] [] []
 (ADD/DELETE)

* CIL RETENTION RATIONALE: (If applicable)

ADEQUATE []
 INADEQUATE []

REMARKS:

NO ISSUE. THE NASA FMEA ITEM IS THE "READY TO LATCH INDICATION CIRCUIT" WITH THE FAILURE MODE AS "ERRONEOUS INDICATION". THE IOA FMEAs ADDRESS THE INDIVIDUAL COMPONENTS. FOR COMPARISON PURPOSES, IOA RECOMMENDS COMBINING THE FOLLOWING IOA FMEAs: 4213 THRU 4216, 4247 THRU 4750, 4269 THRU 4272, 4291 THRU 4294, 4313 THRU 4316, AND 4335 THRU 4338.

APPENDIX C
ASSESSMENT WORKSHEET

ASSESSMENT DATE: 1/25/88	NASA DATA:
ASSESSMENT ID: RMS-4216	BASELINE []
NASA FMEA #: 05-6IC-MRL-12	NEW [X]
SUBSYSTEM: RMS/EPD&C	
MDAC ID: 4216	
ITEM: RESISTOR, R63	
LEAD ANALYST: ROBINSON	

ASSESSMENT:

	CRITICALITY FLIGHT HDW/FUNC		REDUNDANCY SCREENS				CIL ITEM
		A	B	C			
NASA	[3 / 3]	[N]	[N]	[N]		[] *	
IOA	[3 / 3]	[]	[]	[]		[]	
COMPARE	[/]	[N]	[N]	[N]		[]	

RECOMMENDATIONS: (If different from NASA)

[/] [] [] [] []

(ADD/DELETE)

* CIL RETENTION RATIONALE: (If applicable)

ADEQUATE	[]
INADEQUATE	[]

REMARKS:

NO ISSUE. THE NASA FMEA ITEM IS THE "READY TO LATCH INDICATION CIRCUIT" WITH THE FAILURE MODE AS "ERRONEOUS INDICATION". THE IOA FMEAs ADDRESS THE INDIVIDUAL COMPONENTS. FOR COMPARISON PURPOSES, IOA RECOMMENDS COMBINING THE FOLLOWING IOA FMEAs: 4213 THRU 4216, 4247 THRU 4750, 4269 THRU 4272, 4291 THRU 4294, 4313 THRU 4316, AND 4335 THRU 4338.

APPENDIX C
ASSESSMENT WORKSHEET

ASSESSMENT DATE: 1/30/88
 ASSESSMENT ID: RMS-4217
 NASA FMEA #: 05-6IC-MRL-7

NASA DATA:
 BASELINE []
 NEW [X]

SUBSYSTEM: RMS/EPD&C
 MDAC ID: 4217
 ITEM: RESISTOR, R2

LEAD ANALYST: ROBINSON

ASSESSMENT:

	CRITICALITY FLIGHT HDW/FUNC	REDUNDANCY SCREENS			CIL ITEM
		A	B	C	
NASA	[3 /1R]	[P]	[P]	[P]	[] *
IOA	[3 /3]	[]	[]	[]	[]
COMPARE	[/N]	[N]	[N]	[N]	[]

RECOMMENDATIONS: (If different from NASA)

[/] [] [] [] []
 (ADD/DELETE)

* CIL RETENTION RATIONALE: (If applicable)

ADEQUATE []
 INADEQUATE []

REMARKS:

IOA CONCURS WITH NASA FMEA. UPGRADE IOA CRIT TO 3/1R AND CORRECT IOA SCREENS. SUBSEQUENT MULTIPLE FAILURES COULD CAUSE MOTOR BURNOUT AND COULD LEAD TO INABILITY TO SAFELY LATCH THE RMS AND SUBSEQUENT FAILURE OF THE GUILLOTINE/JETTISON SYSTEM WHICH COULD CAUSE LOSS OF CREW/VEHICLE. THIS ONE NASA FMEA CORRESPONDS TO THE FOLLOWING 12 IOA FMEAs: 4217, 4218, 4251, 4252, 4273, 4274, 4295, 4296, 4317, 4318, 4339 AND 4340. IOA RECOMMENDS COMBINING ALL LISTED IOA FMEAs INTO ONE TO ALLOW COMPARISON WITH NASA POST 51L FMEA.

APPENDIX C
ASSESSMENT WORKSHEET

ASSESSMENT DATE: 1/30/88
 ASSESSMENT ID: RMS-4218
 NASA FMEA #: 05-6IC-MRL-7

NASA DATA:
 BASELINE []
 NEW [X]

SUBSYSTEM: RMS/EPD&C
 MDAC ID: 4218
 ITEM: RESISTOR, R14

LEAD ANALYST: ROBINSON

ASSESSMENT:

	CRITICALITY FLIGHT HDW/FUNC	REDUNDANCY SCREENS			CIL ITEM
		A	B	C	
NASA	[3 /1R]	[P]	[P]	[P]	[] *
IOA	[3 /3]	[]	[]	[]	[]
COMPARE	[/N]	[N]	[N]	[N]	[]

RECOMMENDATIONS: (If different from NASA)

[/] [] [] [] []
 (ADD/DELETE)

* CIL RETENTION RATIONALE: (If applicable)

ADEQUATE []
 INADEQUATE []

REMARKS:

IOA CONCURS WITH NASA FMEA. UPGRADE IOA CRIT TO 3/1R AND CORRECT IOA SCREENS. SUBSEQUENT MULTIPLE FAILURES COULD CAUSE MOTOR BURNOUT AND COULD LEAD TO INABILITY TO SAFELY LATCH THE RMS AND SUBSEQUENT FAILURE OF THE GUILLOTINE/JETTISON SYSTEM WHICH COULD CAUSE LOSS OF CREW/VEHICLE. THIS ONE NASA FMEA CORRESPONDS TO THE FOLLOWING 12 IOA FMEAs: 4217, 4218, 4251, 4252, 4273, 4274, 4295, 4296, 4317, 4318, 4339 AND 4340. IOA RECOMMENDS COMBINING ALL LISTED IOA FMEAs INTO ONE TO ALLOW COMPARISON WITH NASA POST 51L FMEA.

APPENDIX C
ASSESSMENT WORKSHEET

ASSESSMENT DATE: 1/25/88
 ASSESSMENT ID: RMS-4219
 NASA FMEA #: 05-6IC-MRL-11

NASA DATA:
 BASELINE []
 NEW [X]

SUBSYSTEM: RMS/EPD&C
 MDAC ID: 4219
 ITEM: RESISTOR, R25

LEAD ANALYST: ROBINSON

ASSESSMENT:

	CRITICALITY FLIGHT HDW/FUNC	REDUNDANCY SCREENS			CIL ITEM
		A	B	C	
NASA	[3 / 3]	[N]	[N]	[N]	[] *
IOA	[3 / 3]	[]	[]	[]	[]
COMPARE	[/]	[N]	[N]	[N]	[]

RECOMMENDATIONS: (If different from NASA)

[/] [] [] [] []
 (ADD/DELETE)

* CIL RETENTION RATIONALE: (If applicable)

ADEQUATE []
 INADEQUATE []

REMARKS:

NO ISSUE. THE NASA FMEA ITEM IS "INDICATION CIRCUIT - HYBRID DRIVER TYPE 1, RESISTORS & EVENT INDICATION", AND INCLUDES SYSTEM 1 FWD/MID/AFT PEDESTAL CIRCUIT COMPONENTS. FOR COMPARISON, IOA RECOMMENDS COMBINING THE FOLLOWING IOA FMEAs: 4219 THRU 4234, 4253 THRU 4256, 4275 THRU 4278, 4297 THRU 4300, 4319 THRU 4322 AND 4341 THRU 4344. FMEAs WITH 3/3 CRIT DO NOT REQUIRE ASSESSMENT.

APPENDIX C
ASSESSMENT WORKSHEET

ASSESSMENT DATE: 1/25/88
 ASSESSMENT ID: RMS-4220
 NASA FMEA #: 05-6IC-MRL-11

NASA DATA:
 BASELINE []
 NEW [X]

SUBSYSTEM: RMS/EPD&C
 MDAC ID: 4220
 ITEM: RESISTOR, R32

LEAD ANALYST: ROBINSON

ASSESSMENT:

	CRITICALITY FLIGHT HDW/FUNC	REDUNDANCY SCREENS			CIL ITEM
		A	B	C	
NASA	[3 / 3]	[]	[]	[]	[] *
IOA	[3 / 3]	[]	[]	[]	[]
COMPARE	[/]	[]	[]	[]	[]

RECOMMENDATIONS: (If different from NASA)

[/] [] [] [] []
 (ADD/DELETE)

* CIL RETENTION RATIONALE: (If applicable)

ADEQUATE []
 INADEQUATE []

REMARKS:

NO ISSUE. THE NASA FMEA ITEM IS "INDICATION CIRCUIT - HYBRID DRIVER TYPE 1, RESISTORS & EVENT INDICATION", AND INCLUDES SYSTEM 1 FWD/MID/AFT PEDESTAL CIRCUIT COMPONENTS. FOR COMPARISON, IOA RECOMMENDS COMBINING THE FOLLOWING IOA FMEAs: 4219 THRU 4234, 4253 THRU 4256, 4275 THRU 4278, 4297 THRU 4300, 4319 THRU 4322 AND 4341 THRU 4344. FMEAs WITH 3/3 CRIT DO NOT REQUIRE ASSESSMENT.

APPENDIX C
ASSESSMENT WORKSHEET

ASSESSMENT DATE: 1/25/88
 ASSESSMENT ID: RMS-4221
 NASA FMEA #: 05-6IC-MRL-11

NASA DATA:
 BASELINE []
 NEW [X]

SUBSYSTEM: RMS/EPD&C
 MDAC ID: 4221
 ITEM: RESISTOR, R26

LEAD ANALYST: ROBINSON

ASSESSMENT:

	CRITICALITY FLIGHT HDW/FUNC	REDUNDANCY SCREENS			CIL ITEM
		A	B	C	
NASA	[3 / 3]	[]	[]	[]	[] *
IOA	[3 / 3]	[]	[]	[]	[]
COMPARE	[/]	[]	[]	[]	[]

RECOMMENDATIONS: (If different from NASA)

[/] [] [] [] []
 (ADD/DELETE)

* CIL RETENTION RATIONALE: (If applicable)

ADEQUATE []
 INADEQUATE []

REMARKS:

NO ISSUE. THE NASA FMEA ITEM IS "INDICATION CIRCUIT - HYBRID DRIVER TYPE 1, RESISTORS & EVENT INDICATION", AND INCLUDES SYSTEM 1 FWD/MID/AFT PEDESTAL CIRCUIT COMPONENTS. FOR COMPARISON, IOA RECOMMENDS COMBINING THE FOLLOWING IOA FMEAs: 4219 THRU 4234, 4253 THRU 4256, 4275 THRU 4278, 4297 THRU 4300, 4319 THRU 4322 AND 4341 THRU 4344. FMEAs WITH 3/3 CRIT DO NOT REQUIRE ASSESSMENT.

APPENDIX C
ASSESSMENT WORKSHEET

ASSESSMENT DATE: 1/25/88
 ASSESSMENT ID: RMS-4222
 NASA FMEA #: 05-6IC-MRL-11

NASA DATA:
 BASELINE []
 NEW [X]

SUBSYSTEM: RMS/EPD&C
 MDAC ID: 4222
 ITEM: RESISTOR, R33

LEAD ANALYST: ROBINSON

ASSESSMENT:

	CRITICALITY FLIGHT HDW/FUNC	REDUNDANCY SCREENS			CIL ITEM
		A	B	C	
NASA	[3 / 3]	[]	[]	[]	[] *
IOA	[3 / 3]	[]	[]	[]	[]
COMPARE	[/]	[]	[]	[]	[]

RECOMMENDATIONS: (If different from NASA)

[/] [] [] [] []
 (ADD/DELETE)

* CIL RETENTION RATIONALE: (If applicable)

ADEQUATE []
 INADEQUATE []

REMARKS:

NO ISSUE. THE NASA FMEA ITEM IS "INDICATION CIRCUIT - HYBRID DRIVER TYPE 1, RESISTORS & EVENT INDICATION", AND INCLUDES SYSTEM 1 FWD/MID/AFT PEDESTAL CIRCUIT COMPONENTS. FOR COMPARISON, IOA RECOMMENDS COMBINING THE FOLLOWING IOA FMEAs: 4219 THRU 4234, 4253 THRU 4256, 4275 THRU 4278, 4297 THRU 4300, 4319 THRU 4322 AND 4341 THRU 4344. FMEAs WITH 3/3 CRIT DO NOT REQUIRE ASSESSMENT.

APPENDIX C
ASSESSMENT WORKSHEET

ASSESSMENT DATE: 1/25/88
 ASSESSMENT ID: RMS-4223
 NASA FMEA #: 05-6IC-MRL-11

NASA DATA:
 BASELINE []
 NEW [X]

SUBSYSTEM: RMS/EPD&C
 MDAC ID: 4223
 ITEM: HYBRID DRIVER, AR4

LEAD ANALYST: ROBINSON

ASSESSMENT:

	CRITICALITY FLIGHT HDW/FUNC	REDUNDANCY SCREENS			CIL ITEM
		A	B	C	
NASA	[3 / 3]	[]	[]	[]	[] *
IOA	[3 / 3]	[]	[]	[]	[]
COMPARE	[/]	[]	[]	[]	[]

RECOMMENDATIONS: (If different from NASA)

[/] [] [] [] []
 (ADD/DELETE)

* CIL RETENTION RATIONALE: (If applicable)

ADEQUATE []
 INADEQUATE []

REMARKS:

NO ISSUE. THE NASA FMEA ITEM IS "INDICATION CIRCUIT - HYBRID DRIVER TYPE 1, RESISTORS & EVENT INDICATION", AND INCLUDES SYSTEM 1 FWD/MID/AFT PEDESTAL CIRCUIT COMPONENTS. FOR COMPARISON, IOA RECOMMENDS COMBINING THE FOLLOWING IOA FMEAs: 4219 THRU 4234, 4253 THRU 4256, 4275 THRU 4278, 4297 THRU 4300, 4319 THRU 4322 AND 4341 THRU 4344. FMEAs WITH 3/3 CRIT DO NOT REQUIRE ASSESSMENT.

APPENDIX C
ASSESSMENT WORKSHEET

ASSESSMENT DATE: 1/25/88
 ASSESSMENT ID: RMS-4224
 NASA FMEA #: 05-6IC-MRL-11

NASA DATA:
 BASELINE []
 NEW [X]

SUBSYSTEM: RMS/EPD&C
 MDAC ID: 4224
 ITEM: HYBRID DRIVER, AR4

LEAD ANALYST: ROBINSON

ASSESSMENT:

	CRITICALITY FLIGHT HDW/FUNC	REDUNDANCY SCREENS			CIL ITEM
		A	B	C	
NASA	[3 / 3]	[]	[]	[]	[] *
IOA	[3 / 3]	[]	[]	[]	[]
COMPARE	[/]	[]	[]	[]	[]

RECOMMENDATIONS: (If different from NASA)

[/] [] [] [] []
 (ADD/DELETE)

* CIL RETENTION RATIONALE: (If applicable)

ADEQUATE []
 INADEQUATE []

REMARKS:

NO ISSUE. THE NASA FMEA ITEM IS "INDICATION CIRCUIT - HYBRID DRIVER TYPE 1, RESISTORS & EVENT INDICATION", AND INCLUDES SYSTEM 1 FWD/MID/AFT PEDESTAL CIRCUIT COMPONENTS. FOR COMPARISON, IOA RECOMMENDS COMBINING THE FOLLOWING IOA FMEAs: 4219 THRU 4234, 4253 THRU 4256, 4275 THRU 4278, 4297 THRU 4300, 4319 THRU 4322 AND 4341 THRU 4344. FMEAs WITH 3/3 CRIT DO NOT REQUIRE ASSESSMENT.

APPENDIX C
ASSESSMENT WORKSHEET

ASSESSMENT DATE: 1/25/88
 ASSESSMENT ID: RMS-4225
 NASA FMEA #: 05-6IC-MRL-11

NASA DATA:
 BASELINE []
 NEW [X]

SUBSYSTEM: RMS/EPD&C
 MDAC ID: 4225
 ITEM: HYBRID DRIVER, AR10

LEAD ANALYST: ROBINSON

ASSESSMENT:

	CRITICALITY FLIGHT HDW/FUNC	REDUNDANCY SCREENS			CIL ITEM
		A	B	C	
NASA	[3 / 3]	[]	[]	[]	[] *
IOA	[3 / 3]	[]	[]	[]	[]
COMPARE	[/]	[]	[]	[]	[]

RECOMMENDATIONS: (If different from NASA)

[/] [] [] [] []
 (ADD/DELETE)

* CIL RETENTION RATIONALE: (If applicable)

ADEQUATE []
 INADEQUATE []

REMARKS:

NO ISSUE. THE NASA FMEA ITEM IS "INDICATION CIRCUIT - HYBRID DRIVER TYPE 1, RESISTORS & EVENT INDICATION", AND INCLUDES SYSTEM 1 FWD/MID/AFT PEDESTAL CIRCUIT COMPONENTS. FOR COMPARISON, IOA RECOMMENDS COMBINING THE FOLLOWING IOA FMEAs: 4219 THRU 4234, 4253 THRU 4256, 4275 THRU 4278, 4297 THRU 4300, 4319 THRU 4322 AND 4341 THRU 4344. FMEAs WITH 3/3 CRIT DO NOT REQUIRE ASSESSMENT.

APPENDIX C
ASSESSMENT WORKSHEET

ASSESSMENT DATE: 1/25/88
 ASSESSMENT ID: RMS-4226
 NASA FMEA #: 05-6IC-MRL-11

NASA DATA:
 BASELINE []
 NEW [X]

SUBSYSTEM: RMS/EPD&C
 MDAC ID: 4226
 ITEM: HYBRID DRIVER, AR10

LEAD ANALYST: ROBINSON

ASSESSMENT:

	CRITICALITY FLIGHT HDW/FUNC	REDUNDANCY SCREENS			CIL ITEM
		A	B	C	
NASA	[3 / 3]	[]	[]	[]	[] *
IOA	[3 / 3]	[]	[]	[]	[]
COMPARE	[/]	[]	[]	[]	[]

RECOMMENDATIONS: (If different from NASA)

[/] [] [] [] []
 (ADD/DELETE)

* CIL RETENTION RATIONALE: (If applicable)

ADEQUATE []
 INADEQUATE []

REMARKS:

NO ISSUE. THE NASA FMEA ITEM IS "INDICATION CIRCUIT - HYBRID DRIVER TYPE 1, RESISTORS & EVENT INDICATION", AND INCLUDES SYSTEM 1 FWD/MID/AFT PEDESTAL CIRCUIT COMPONENTS. FOR COMPARISON, IOA RECOMMENDS COMBINING THE FOLLOWING IOA FMEAs: 4219 THRU 4234, 4253 THRU 4256, 4275 THRU 4278, 4297 THRU 4300, 4319 THRU 4322 AND 4341 THRU 4344. FMEAs WITH 3/3 CRIT DO NOT REQUIRE ASSESSMENT.

APPENDIX C
ASSESSMENT WORKSHEET

ASSESSMENT DATE: 1/25/88
 ASSESSMENT ID: RMS-4227
 NASA FMEA #: 05-6IC-MRL-11

NASA DATA:
 BASELINE []
 NEW [X]

SUBSYSTEM: RMS/EPD&C
 MDAC ID: 4227
 ITEM: HYBRID DRIVER, AR5

LEAD ANALYST: ROBINSON

ASSESSMENT:

	CRITICALITY FLIGHT HDW/FUNC	REDUNDANCY SCREENS			CIL ITEM
		A	B	C	
NASA	[3 / 3]	[]	[]	[]	[] *
IOA	[3 / 3]	[]	[]	[]	[]
COMPARE	[/]	[]	[]	[]	[]

RECOMMENDATIONS: (If different from NASA)

[/] [] [] [] []
 (ADD/DELETE)

* CIL RETENTION RATIONALE: (If applicable)

ADEQUATE []
 INADEQUATE []

REMARKS:

NO ISSUE. THE NASA FMEA ITEM IS "INDICATION CIRCUIT - HYBRID DRIVER TYPE 1, RESISTORS & EVENT INDICATION", AND INCLUDES SYSTEM 1 FWD/MID/AFT PEDESTAL CIRCUIT COMPONENTS. FOR COMPARISON, IOA RECOMMENDS COMBINING THE FOLLOWING IOA FMEAs: 4219 THRU 4234, 4253 THRU 4256, 4275 THRU 4278, 4297 THRU 4300, 4319 THRU 4322 AND 4341 THRU 4344. FMEAs WITH 3/3 CRIT DO NOT REQUIRE ASSESSMENT.

APPENDIX C
ASSESSMENT WORKSHEET

ASSESSMENT DATE: 1/25/88
 ASSESSMENT ID: RMS-4228
 NASA FMEA #: 05-6IC-MRL-11

NASA DATA:
 BASELINE []
 NEW [X]

SUBSYSTEM: RMS/EPD&C
 MDAC ID: 4228
 ITEM: HYBRID DRIVER, AR5

LEAD ANALYST: ROBINSON

ASSESSMENT:

	CRITICALITY FLIGHT HDW/FUNC	REDUNDANCY SCREENS			CIL ITEM
		A	B	C	
NASA	[3 / 3]	[]	[]	[]	[] *
IOA	[3 / 3]	[]	[]	[]	[]
COMPARE	[/]	[]	[]	[]	[]

RECOMMENDATIONS: (If different from NASA)

[/] [] [] [] []
 (ADD/DELETE)

* CIL RETENTION RATIONALE: (If applicable)

ADEQUATE []
 INADEQUATE []

REMARKS:

NO ISSUE. THE NASA FMEA ITEM IS "INDICATION CIRCUIT - HYBRID DRIVER TYPE 1, RESISTORS & EVENT INDICATION", AND INCLUDES SYSTEM 1 FWD/MID/AFT PEDESTAL CIRCUIT COMPONENTS. FOR COMPARISON, IOA RECOMMENDS COMBINING THE FOLLOWING IOA FMEAs: 4219 THRU 4234, 4253 THRU 4256, 4275 THRU 4278, 4297 THRU 4300, 4319 THRU 4322 AND 4341 THRU 4344. FMEAs WITH 3/3 CRIT DO NOT REQUIRE ASSESSMENT.

APPENDIX C
ASSESSMENT WORKSHEET

ASSESSMENT DATE: 1/25/88
 ASSESSMENT ID: RMS-4229
 NASA FMEA #: 05-6IC-MRL-11

NASA DATA:
 BASELINE []
 NEW [X]

SUBSYSTEM: RMS/EPD&C
 MDAC ID: 4229
 ITEM: HYBRID DRIVER, AR13

LEAD ANALYST: ROBINSON

ASSESSMENT:

	CRITICALITY FLIGHT HDW/FUNC	REDUNDANCY SCREENS			CIL ITEM
		A	B	C	
NASA	[3 / 3]	[]	[]	[]	[] *
IOA	[3 / 3]	[]	[]	[]	[]
COMPARE	[/]	[]	[]	[]	[]

RECOMMENDATIONS: (If different from NASA)

[/] [] [] [] []
 (ADD/DELETE)

* CIL RETENTION RATIONALE: (If applicable)

ADEQUATE []
 INADEQUATE []

REMARKS:

NO ISSUE. THE NASA FMEA ITEM IS "INDICATION CIRCUIT - HYBRID DRIVER TYPE 1, RESISTORS & EVENT INDICATION", AND INCLUDES SYSTEM 1 FWD/MID/AFT PEDESTAL CIRCUIT COMPONENTS. FOR COMPARISON, IOA RECOMMENDS COMBINING THE FOLLOWING IOA FMEAs: 4219 THRU 4234, 4253 THRU 4256, 4275 THRU 4278, 4297 THRU 4300, 4319 THRU 4322 AND 4341 THRU 4344. FMEAs WITH 3/3 CRIT DO NOT REQUIRE ASSESSMENT.

APPENDIX C
ASSESSMENT WORKSHEET

ASSESSMENT DATE: 1/25/88
 ASSESSMENT ID: RMS-4230
 NASA FMEA #: 05-6IC-MRL-11

NASA DATA:
 BASELINE []
 NEW [X]

SUBSYSTEM: RMS/EPD&C
 MDAC ID: 4230
 ITEM: HYBRID DRIVER, AR13

LEAD ANALYST: ROBINSON

ASSESSMENT:

	CRITICALITY FLIGHT HDW/FUNC	REDUNDANCY SCREENS			CIL ITEM
		A	B	C	
NASA	[3 / 3]	[]	[]	[]	[] *
IOA	[3 / 3]	[]	[]	[]	[]
COMPARE	[/]	[]	[]	[]	[]

RECOMMENDATIONS: (If different from NASA)

[/] [] [] [] []
 (ADD/DELETE)

* CIL RETENTION RATIONALE: (If applicable)

ADEQUATE []
 INADEQUATE []

REMARKS:

NO ISSUE. THE NASA FMEA ITEM IS "INDICATION CIRCUIT - HYBRID DRIVER TYPE 1, RESISTORS & EVENT INDICATION", AND INCLUDES SYSTEM 1 FWD/MID/AFT PEDESTAL CIRCUIT COMPONENTS. FOR COMPARISON, IOA RECOMMENDS COMBINING THE FOLLOWING IOA FMEAs: 4219 THRU 4234, 4253 THRU 4256, 4275 THRU 4278, 4297 THRU 4300, 4319 THRU 4322 AND 4341 THRU 4344. FMEAs WITH 3/3 CRIT DO NOT REQUIRE ASSESSMENT.

APPENDIX C
ASSESSMENT WORKSHEET

ASSESSMENT DATE: 1/25/88
 ASSESSMENT ID: RMS-4231
 NASA FMEA #: 05-6IC-MRL-11

NASA DATA:
 BASELINE []
 NEW [X]

SUBSYSTEM: RMS/EPD&C
 MDAC ID: 4231
 ITEM: FUSE, AR4F1

LEAD ANALYST: ROBINSON

ASSESSMENT:

	CRITICALITY FLIGHT HDW/FUNC	REDUNDANCY SCREENS			CIL ITEM
		A	B	C	
NASA	[3 / 3]	[]	[]	[]	[] *
IOA	[3 / 3]	[]	[]	[]	[]
COMPARE	[/]	[]	[]	[]	[]

RECOMMENDATIONS: (If different from NASA)

[/] [] [] [] []
 (ADD/DELETE)

* CIL RETENTION RATIONALE: (If applicable)

ADEQUATE []
 INADEQUATE []

REMARKS:

NO ISSUE. THE NASA FMEA ITEM IS "INDICATION CIRCUIT - HYBRID DRIVER TYPE 1, RESISTORS & EVENT INDICATION", AND INCLUDES SYSTEM 1 FWD/MID/AFT PEDESTAL CIRCUIT COMPONENTS. FOR COMPARISON, IOA RECOMMENDS COMBINING THE FOLLOWING IOA FMEAs: 4219 THRU 4234, 4253 THRU 4256, 4275 THRU 4278, 4297 THRU 4300, 4319 THRU 4322 AND 4341 THRU 4344. FMEAs WITH 3/3 CRIT DO NOT REQUIRE ASSESSMENT.

APPENDIX C
ASSESSMENT WORKSHEET

ASSESSMENT DATE: 1/25/88
 ASSESSMENT ID: RMS-4232
 NASA FMEA #: 05-6IC-MRL-11

NASA DATA:
 BASELINE []
 NEW [X]

SUBSYSTEM: RMS/EPD&C
 MDAC ID: 4232
 ITEM: FUSE, AR10F1

LEAD ANALYST: ROBINSON

ASSESSMENT:

	CRITICALITY FLIGHT HDW/FUNC	REDUNDANCY SCREENS			CIL ITEM
		A	B	C	
NASA	[3 / 3]	[]	[]	[]	[] *
IOA	[3 / 3]	[]	[]	[]	[]
COMPARE	[/]	[]	[]	[]	[]

RECOMMENDATIONS: (If different from NASA)

[/] [] [] [] []
 (ADD/DELETE)

* CIL RETENTION RATIONALE: (If applicable)

ADEQUATE []
 INADEQUATE []

REMARKS:

NO ISSUE. THE NASA FMEA ITEM IS "INDICATION CIRCUIT - HYBRID DRIVER TYPE 1, RESISTORS & EVENT INDICATION", AND INCLUDES SYSTEM 1 FWD/MID/AFT PEDESTAL CIRCUIT COMPONENTS. FOR COMPARISON, IOA RECOMMENDS COMBINING THE FOLLOWING IOA FMEAs: 4219 THRU 4234, 4253 THRU 4256, 4275 THRU 4278, 4297 THRU 4300, 4319 THRU 4322 AND 4341 THRU 4344. FMEAs WITH 3/3 CRIT DO NOT REQUIRE ASSESSMENT.

APPENDIX C
ASSESSMENT WORKSHEET

ASSESSMENT DATE: 1/25/88
 ASSESSMENT ID: RMS-4233
 NASA FMEA #: 05-6IC-MRL-11

NASA DATA:
 BASELINE []
 NEW [X]

SUBSYSTEM: RMS/EPD&C
 MDAC ID: 4233
 ITEM: FUSE, AR5F1

LEAD ANALYST: ROBINSON

ASSESSMENT:

	CRITICALITY FLIGHT HDW/FUNC	REDUNDANCY SCREENS			CIL ITEM
		A	B	C	
NASA	[3 / 3]	[]	[]	[]	[] *
IOA	[3 / 3]	[]	[]	[]	[]
COMPARE	[/]	[]	[]	[]	[]

RECOMMENDATIONS: (If different from NASA)

[/] [] [] [] []
 (ADD/DELETE)

* CIL RETENTION RATIONALE: (If applicable)

ADEQUATE []
 INADEQUATE []

REMARKS:

NO ISSUE. THE NASA FMEA ITEM IS "INDICATION CIRCUIT - HYBRID DRIVER TYPE 1, RESISTORS & EVENT INDICATION", AND INCLUDES SYSTEM 1 FWD/MID/AFT PEDESTAL CIRCUIT COMPONENTS. FOR COMPARISON, IOA RECOMMENDS COMBINING THE FOLLOWING IOA FMEAs: 4219 THRU 4234, 4253 THRU 4256, 4275 THRU 4278, 4297 THRU 4300, 4319 THRU 4322 AND 4341 THRU 4344. FMEAs WITH 3/3 CRIT DO NOT REQUIRE ASSESSMENT.

APPENDIX C
ASSESSMENT WORKSHEET

ASSESSMENT DATE: 1/25/88
 ASSESSMENT ID: RMS-4234
 NASA FMEA #: 05-6IC-MRL-11

NASA DATA:
 BASELINE []
 NEW [X]

SUBSYSTEM: RMS/EPD&C
 MDAC ID: 4234
 ITEM: FUSE, AR13F1

LEAD ANALYST: ROBINSON

ASSESSMENT:

	CRITICALITY FLIGHT HDW/FUNC	REDUNDANCY SCREENS			CIL ITEM
		A	B	C	
NASA	[3 / 3]	[]	[]	[]	[] *
IOA	[3 / 3]	[]	[]	[]	[]
COMPARE	[/]	[]	[]	[]	[]

RECOMMENDATIONS: (If different from NASA)

[/] [] [] [] []
 (ADD/DELETE)

* CIL RETENTION RATIONALE: (If applicable)

ADEQUATE []
 INADEQUATE []

REMARKS:

NO ISSUE. THE NASA FMEA ITEM IS "INDICATION CIRCUIT - HYBRID DRIVER TYPE 1, RESISTORS & EVENT INDICATION", AND INCLUDES SYSTEM 1 FWD/MID/AFT PEDESTAL CIRCUIT COMPONENTS. FOR COMPARISON, IOA RECOMMENDS COMBINING THE FOLLOWING IOA FMEAs: 4219 THRU 4234, 4253 THRU 4256, 4275 THRU 4278, 4297 THRU 4300, 4319 THRU 4322 AND 4341 THRU 4344. FMEAs WITH 3/3 CRIT DO NOT REQUIRE ASSESSMENT.

APPENDIX C
ASSESSMENT WORKSHEET

ASSESSMENT DATE: 1/24/88
 ASSESSMENT ID: RMS-4235
 NASA FMEA #: 05-6IC-MRL-4

NASA DATA:
 BASELINE []
 NEW [X]

SUBSYSTEM: RMS/EPD&C
 MDAC ID: 4235
 ITEM: HYBRID RELAY, K55

LEAD ANALYST: ROBINSON

ASSESSMENT:

	CRITICALITY FLIGHT HDW/FUNC	REDUNDANCY SCREENS			CIL ITEM
		A	B	C	
NASA	[3 /1R]	[P]	[P]	[P]	[] *
IOA	[3 /2R]	[]	[NA]	[NA]	[]
COMPARE	[/N]	[N]	[N]	[N]	[]

RECOMMENDATIONS: (If different from NASA)

[/] [] [] [] []
 (ADD/DELETE)

* CIL RETENTION RATIONALE: (If applicable)

ADEQUATE []
 INADEQUATE []

REMARKS:

NO ISSUE.
 IOA CONCURS WITH THE POST 51L CRIT OF 3/1R. IOA SCREENS SHOULD BE 1-P-P. TO COMPARE WITH THE NASA FMEA, IOA RECOMMENDS COMBINING THE FOLLOWING 24 IOA FMEAs: 4201, 4203, 4205, 4207, 4235, 4237, 4239, 4241, 4257, 4259, 4261, 4263, 4279, 4281, 4283, 4285, 4301, 4303, 4305, 4307, 4323, 4325, 4327, AND 4329. THE IOA FMEAs ARE FOR 12 PORT AND 12 STARBOARD HYBRID RELAYS USED BY SYSTEM 1 AND SYSTEM 2, FWD, MID, AND AFT LATCH/RELEASE FOR BOTH PORT AND STARBOARD ARMS.

APPENDIX C
ASSESSMENT WORKSHEET

ASSESSMENT DATE: 1/30/88
 ASSESSMENT ID: RMS-4236
 NASA FMEA #: 05-6IC-MRL-5

NASA DATA:
 BASELINE []
 NEW [X]

SUBSYSTEM: RMS/EPD&C
 MDAC ID: 4236
 ITEM: HYBRID RELAY, K55

LEAD ANALYST: ROBINSON

ASSESSMENT:

	CRITICALITY FLIGHT HDW/FUNC	REDUNDANCY SCREENS			CIL ITEM
		A	B	C	
NASA	[3 /1R]	[P]	[P]	[P]	[] *
IOA	[3 /2R]	[]	[NA]	[NA]	[]
COMPARE	[/N]	[N]	[N]	[N]	[]

RECOMMENDATIONS: (If different from NASA)

[/] [] [] [] []
 (ADD/DELETE)

* CIL RETENTION RATIONALE: (If applicable)

ADEQUATE []
 INADEQUATE []

REMARKS:

NO ISSUE.
 IOA CONCURS WITH THE POST 51L CRIT OF 3/1R. IOA SCREENS SHOULD BE 1-P-P. TO COMPARE WITH THE NASA FMEA, IOA RECOMMENDS COMBINING THE FOLLOWING 12 IOA FMEAs: 4202, 4204, 4236, 4238, 4258, 4260, 4280, 4282, 4302, 4304, 4324, AND 4326. THE 12 IOA FMEAs ARE FOR 6 INDIVIDUAL PORT AND 6 INDIVIDUAL STARBOARD HYBRID RELAYS FOR LATCHING.

APPENDIX C
ASSESSMENT WORKSHEET

ASSESSMENT DATE: 1/24/88
 ASSESSMENT ID: RMS-4237
 NASA FMEA #: 05-6IC-MRL-4

NASA DATA:
 BASELINE []
 NEW [X]

SUBSYSTEM: RMS/EPD&C
 MDAC ID: 4237
 ITEM: HYBRID RELAY, K69

LEAD ANALYST: ROBINSON

ASSESSMENT:

	CRITICALITY FLIGHT HDW/FUNC	REDUNDANCY SCREENS			CIL ITEM
		A	B	C	
NASA	[3 /1R]	[P]	[P]	[P]	[] *
IOA	[3 /2R]	[]	[NA]	[NA]	[]
COMPARE	[/N]	[N]	[N]	[N]	[]

RECOMMENDATIONS: (If different from NASA)

[/] [] [] [] [] (ADD/DELETE)

* CIL RETENTION RATIONALE: (If applicable)

ADEQUATE []
 INADEQUATE []

REMARKS:

NO ISSUE.

IOA CONCURS WITH THE POST 51L CRIT OF 3/1R. IOA SCREENS SHOULD BE 1-P-P. TO COMPARE WITH THE NASA FMEA, IOA RECOMMENDS COMBINING THE FOLLOWING 24 IOA FMEAs: 4201, 4203, 4205, 4207, 4235, 4237, 4239, 4241, 4257, 4259, 4261, 4263, 4279, 4281, 4283, 4285, 4301, 4303, 4305, 4307, 4323, 4325, 4327, AND 4329. THE IOA FMEAs ARE FOR 12 PORT AND 12 STARBOARD HYBRID RELAYS USED BY SYSTEM 1 AND SYSTEM 2, FWD, MID, AND AFT LATCH/RELEASE FOR BOTH PORT AND STARBOARD ARMS.

APPENDIX C
ASSESSMENT WORKSHEET

ASSESSMENT DATE: 1/30/88
 ASSESSMENT ID: RMS-4238
 NASA FMEA #: 05-6IC-MRL-5

NASA DATA:
 BASELINE []
 NEW [X]

SUBSYSTEM: RMS/EPD&C
 MDAC ID: 4238
 ITEM: HYBRID RELAY, K69

LEAD ANALYST: ROBINSON

ASSESSMENT:

	CRITICALITY FLIGHT HDW/FUNC	REDUNDANCY SCREENS			CIL ITEM
		A	B	C	
NASA	[3 /1R]	[P]	[P]	[P]	[] *
IOA	[3 /2R]	[]	[NA]	[NA]	[]
COMPARE	[/N]	[N]	[N]	[N]	[]

RECOMMENDATIONS: (If different from NASA)

[/] [] [] [] []
 (ADD/DELETE)

* CIL RETENTION RATIONALE: (If applicable)

ADEQUATE []
 INADEQUATE []

REMARKS:

NO ISSUE.
 IOA CONCURS WITH THE POST 51L CRIT OF 3/1R. IOA SCREENS SHOULD BE 1 - P - P. IOA RECOMMENDS COMBINING THE FOLLOWING IOA FMEAs TO COMPARE WITH THE NASA FMEA. COMBINE THE FOLLOWING 12 IOA FMEAs: 4202, 4204, 4236, 4238, 4258, 4260, 4280, 4282, 4302, 4304, THE 12 IOA FMEAs ARE FOR 6 INDIVIDUAL PORT AND 6 INDIVIDUAL STARBOARD HYBRID RELAYS FOR LATCHING.

APPENDIX C
ASSESSMENT WORKSHEET

ASSESSMENT DATE: 1/24/88
 ASSESSMENT ID: RMS-4239
 NASA FMEA #: 05-6IC-MRL-4

NASA DATA:
 BASELINE []
 NEW [X]

SUBSYSTEM: RMS/EPD&C
 MDAC ID: 4239
 ITEM: HYBRID RELAY, K43

LEAD ANALYST: ROBINSON

ASSESSMENT:

	CRITICALITY FLIGHT HDW/FUNC	REDUNDANCY SCREENS			CIL ITEM
		A	B	C	
NASA	[3 /IR]	[P]	[P]	[P]	[] *
IOA	[3 /2R]	[]	[NA]	[NA]	[]
COMPARE	[/N]	[N]	[N]	[N]	[]

RECOMMENDATIONS: (If different from NASA)

[/] [] [] [] []
 (ADD/DELETE)

* CIL RETENTION RATIONALE: (If applicable)

ADEQUATE []
 INADEQUATE []

REMARKS:

NO ISSUE.

IOA CONCURS WITH THE POST 51L CRIT OF 3/1R. IOA SCREENS SHOULD BE 1-P-P. TO COMPARE WITH THE NASA FMEA, IOA RECOMMENDS COMBINING THE FOLLOWING 24 IOA FMEAs: 4201, 4203, 4205, 4207, 4235, 4237, 4239, 4241, 4257, 4259, 4261, 4263, 4279, 4281, 4283, 4285, 4301, 4303, 4305, 4307, 4323, 4325, 4327, AND 4329. THE IOA FMEAs ARE FOR 12 PORT AND 12 STARBOARD HYBRID RELAYS USED BY SYSTEM 1 AND SYSTEM 2, FWD, MID, AND AFT LATCH/RELEASE FOR BOTH PORT AND STARBOARD ARMS.

APPENDIX C
ASSESSMENT WORKSHEET

ASSESSMENT DATE: 2/16/88
 ASSESSMENT ID: RMS-4240
 NASA FMEA #: 05-6IC-MRL-6

NASA DATA:
 BASELINE []
 NEW [X]

SUBSYSTEM: RMS/EPD&C
 MDAC ID: 4240
 ITEM: HYBRID RELAY, K43

LEAD ANALYST: ROBINSON

ASSESSMENT:

	CRITICALITY FLIGHT HDW/FUNC	REDUNDANCY SCREENS			CIL ITEM
		A	B	C	
NASA	[2 /IR]	[P]	[F]	[P]	[X] *
IOA	[3 /2R]	[]	[NA]	[NA]	[]
COMPARE	[N /N]	[N]	[N]	[N]	[N]

RECOMMENDATIONS: (If different from NASA)

[/] [] [] [] []
 (ADD/DELETE)

* CIL RETENTION RATIONALE: (If applicable)

ADEQUATE []
 INADEQUATE []

REMARKS:

NO ISSUE.

IOA CONCURS WITH THE POST 51L CRIT OF 3/1R. IOA SCREENS SHOULD BE 1 - P - P. IOA RECOMMENDS COMBINING THE FOLLOWING IOA FMEAs TO COMPARE WITH THE NASA FMEA. COMBINE THE FOLLOWING 6 IOA FMEAs: 4206, 4208, 4240, 4242, 4262, 4264, 4284, 4286, 4306, 4308, THE 12 IOA FMEAs ARE FOR 6 INDIVIDUAL PORT AND 6 INDIVIDUAL STARBOARD HYBRID RELAYS FOR RELEASING.

APPENDIX C
ASSESSMENT WORKSHEET

ASSESSMENT DATE: 1/24/88
 ASSESSMENT ID: RMS-4241
 NASA FMEA #: 05-6IC-MRL-4

NASA DATA:
 BASELINE []
 NEW [X]

SUBSYSTEM: RMS/EPD&C
 MDAC ID: 4241
 ITEM: HYBRID RELAY, K57

LEAD ANALYST: ROBINSON

ASSESSMENT:

	CRITICALITY FLIGHT HDW/FUNC	REDUNDANCY SCREENS			CIL ITEM
		A	B	C	
NASA	[3 /IR]	[P]	[P]	[P]	[] *
IOA	[3 /2R]	[]	[NA]	[NA]	[]
COMPARE	[/N]	[N]	[N]	[N]	[]

RECOMMENDATIONS: (If different from NASA)

[/] [] [] [] []
 (ADD/DELETE)

* CIL RETENTION RATIONALE: (If applicable)

ADEQUATE []
 INADEQUATE []

REMARKS:

NO ISSUE.
 IOA CONCURS WITH THE POST 51L CRIT OF 3/1R. IOA SCREENS SHOULD BE 1-P-P. TO COMPARE WITH THE NASA FMEA, IOA RECOMMENDS COMBINING THE FOLLOWING 24 IOA FMEAs: 4201, 4203, 4205, 4207, 4235, 4237, 4239, 4241, 4257, 4259, 4261, 4263, 4279, 4281, 4283, 4285, 4301, 4303, 4305, 4307, 4323, 4325, 4327, AND 4329. THE IOA FMEAs ARE FOR 12 PORT AND 12 STARBOARD HYBRID RELAYS USED BY SYSTEM 1 AND SYSTEM 2, FWD, MID, AND AFT LATCH/RELEASE FOR BOTH PORT AND STARBOARD ARMS.

APPENDIX C
ASSESSMENT WORKSHEET

ASSESSMENT DATE: 2/16/88	NASA DATA:
ASSESSMENT ID: RMS-4242	BASELINE []
NASA FMEA #: 05-6IC-MRL-6	NEW [X]

SUBSYSTEM: RMS/EPD&C
MDAC ID: 4242
ITEM: HYBRID RELAY, K57

LEAD ANALYST: ROBINSON

ASSESSMENT:

	CRITICALITY FLIGHT HDW/FUNC	REDUNDANCY	SCREENS	CIL ITEM
		A	B	C
NASA	[2 /1R]	[P]	[F]	[P]
IOA	[3 /2R]	[]	[NA]	[NA]
COMPARE	[N /N]	[N]	[N]	[N]

RECOMMENDATIONS: (If different from NASA)

[/] [] [] [] []
(ADD/DELETE)

* CIL RETENTION RATIONALE: (If applicable)

ADEQUATE []
INADEQUATE []

REMARKS:
NO ISSUE.

IOA CONCURS WITH THE POST 51L CRIT OF 3/1R. IOA SCREENS SHOULD BE 1 - P - P. IOA RECOMMENDS COMBINING THE FOLLOWING IOA FMEAS TO COMPARE WITH THE NASA FMEA. COMBINE THE FOLLOWING 6 IOA FMEAS: 4206, 4208, 4240, 4242, 4262, 4264, 4284, 4286, 4306, THE 12 IOA FMEAS ARE FOR 6 INDIVIDUAL PORT AND 6 INDIVIDUAL STARBOARD HYBRID RELAYS FOR RELEASING.

APPENDIX C
ASSESSMENT WORKSHEET

ASSESSMENT DATE: 2/14/88
 ASSESSMENT ID: RMS-4243
 NASA FMEA #: 05-6ID-2127-1

NASA DATA:
 BASELINE []
 NEW [X]

SUBSYSTEM: RMS/EPD&C
 MDAC ID: 4243
 ITEM: RELAY, K57

LEAD ANALYST: ROBINSON

ASSESSMENT:

	CRITICALITY FLIGHT HDW/FUNC	REDUNDANCY SCREENS			CIL ITEM
		A	B	C	
NASA	[2 /1R]	[P]	[P]	[P]	[X] *
IOA	[3 /2R]	[]	[NA]	[NA]	[]
COMPARE	[N /N]	[N]	[N]	[N]	[N]

RECOMMENDATIONS: (If different from NASA)

[/] [] [] [P] []
 (ADD/DELETE)

* CIL RETENTION RATIONALE: (If applicable)

ADEQUATE []
 INADEQUATE []

REMARKS:

NO ISSUE. RECOMMEND UPGRADING IOA FMEA TO CRITICALITY 2/1R.
 THE IOA FMEA FOR FAILURE OF THESE RELAYS WAS GENERATED AS PART OF
 THE MANIPULATOR RETENTION LATCH CONTROL CIRCUIT WHICH IS 05-6IC
 SET OF NASA FMEAS ALSO AND THEREFORE THE RESULT OF THE FAILURES
 DO NOT MATCH WHEN COMPARED. THE RELAYS ARE 4 POLE, 2
 POSITION LATCHING RELAYS AND APPEAR IN BOTH THE LATCH CONTROL AND
 THE JETTISON/GUILLOTINE CIRCUITS. IOA CONCURS WITH THE NASA
 FAILURE.

APPENDIX C
ASSESSMENT WORKSHEET

ASSESSMENT DATE: 2/14/88
 ASSESSMENT ID: RMS-4244
 NASA FMEA #: 05-6ID-2130-1

NASA DATA:
 BASELINE [X]
 NEW []

SUBSYSTEM: RMS/EPD&C
 MDAC ID: 4244
 ITEM: RELAY, K80

LEAD ANALYST: ROBINSON

ASSESSMENT:

	CRITICALITY FLIGHT HDW/FUNC	REDUNDANCY SCREENS			CIL ITEM
		A	B	C	
NASA	[3 /3]	[P]	[P]	[P]	[] *
IOA	[3 /2R]	[P]	[NA]	[NA]	[]
COMPARE	[/N]	[]	[N]	[N]	[]

RECOMMENDATIONS: (If different from NASA)

[3 /2R] [] [] [P] []
 (ADD/DELETE)

* CIL RETENTION RATIONALE: (If applicable)

ADEQUATE []
 INADEQUATE []

REMARKS:

RECOMMEND UPGRADING THE NASA FMEA TO 3/2R. RECOMMEND COMBINING COMPONENTS IN IOA FMEAs 4244 AND 4310. THE IOA FMEA FOR FAILURE OF THESE RELAYS WAS GENERATED AS PART OF THE MANIPULATOR RETENTION LATCH CONTROL CIRCUIT WHICH IS 05-6I SET OF NASA FMEAS ALSO AND THEREFORE THE RESULT OF THE FAILURES DO NOT MATCH WHEN COMPARED. THE RELAYS ARE 4 POLE, 2 POSITION LATCHING RELAYS AND APPEAR IN BOTH THE LATCH CONTROL AND THE JETTISON/GUILLOTINE CIRCUITS. IOA CONCURS WITH THE NASA FAILURE.

APPENDIX C
ASSESSMENT WORKSHEET

ASSESSMENT DATE: 1/30/88
 ASSESSMENT ID: RMS-4245
 NASA FMEA #: 05-6IC-MRL-7A

NASA DATA:
 BASELINE []
 NEW [X]

SUBSYSTEM: RMS/EPD&C
 MDAC ID: 4245
 ITEM: FUSE, F2

LEAD ANALYST: ROBINSON

ASSESSMENT:

	CRITICALITY FLIGHT HDW/FUNC	REDUNDANCY SCREENS			CIL ITEM
		A	B	C	
NASA	[3 /1R]	[P]	[P]	[P]	[] *
IOA	[3 /3]	[]	[]	[]	[]
COMPARE	[/N]	[N]	[N]	[N]	[]

RECOMMENDATIONS: (If different from NASA)

[/] [] [] [] []
 (ADD/DELETE)

* CIL RETENTION RATIONALE: (If applicable)

ADEQUATE []
 INADEQUATE []

REMARKS:

UPGRADE IOA CRIT TO 3/1R AND CORRECT IOA SCREENS. SUBSEQUENT MULTIPLE FAILURES COULD CAUSE MOTOR BURNOUT AND COULD LEAD TO INABILITY TO SAFELY LATCH THE RMS AND SUBSEQUENT FAILURE OF THE GUILLOTINE/JETTISON SYSTEM
 COULD RESULT IN LOSS OF CREW/VEHICLE. THIS ONE NASA FMEA CORRESPONDS TO THE FOLLOWING IOA FMEAs: 4211, 4212, 4245, 4246, 4267, 4268, 4289, 4290, 4311, 4312, 4333, AND 4334. IOA RECOMMENDS COMBINING ALL LISTED IOA FMEAs INTO ONE TO ALLOW COMPARISON WITH THE NASA POST 51L FMEA.

APPENDIX C
ASSESSMENT WORKSHEET

ASSESSMENT DATE: 1/30/88
 ASSESSMENT ID: RMS-4246
 NASA FMEA #: 05-6IC-MRL-7A

NASA DATA:
 BASELINE []
 NEW [X]

SUBSYSTEM: RMS/EPD&C
 MDAC ID: 4246
 ITEM: FUSE, F4

LEAD ANALYST: ROBINSON

ASSESSMENT:

	CRITICALITY FLIGHT HDW/FUNC	REDUNDANCY SCREENS			CIL ITEM
		A	B	C	
NASA	[3 /1R]	[P]	[P]	[P]	[] *
IOA	[3 /3]	[]	[]	[]	[]
COMPARE	[/N]	[N]	[N]	[N]	[]

RECOMMENDATIONS: (If different from NASA)

[/] [] [] [] []
 (ADD/DELETE)

* CIL RETENTION RATIONALE: (If applicable)

ADEQUATE []
 INADEQUATE []

REMARKS:

UPGRADE IOA CRIT TO 3/1R AND CORRECT IOA SCREENS. SUBSEQUENT MULTIPLE FAILURES COULD CAUSE MOTOR BURNOUT AND COULD LEAD TO INABILITY TO SAFELY LATCH THE RMS AND SUBSEQUENT FAILURE OF THE GUILLOTINE/JETTISON SYSTEM COULD RESULT IN LOSS OF CREW/VEHICLE. THIS ONE NASA FMEA CORRESPONDS TO THE FOLLOWING IOA FMEAs: 4211, 4212, 4245, 4246, 4267, 4268, 4289, 4290, 4311, 4312, 4333, AND 4334. IOA RECOMMENDS COMBINING ALL LISTED IOA FMEAs INTO ONE TO ALLOW COMPARISON WITH THE NASA POST 51L FMEA.

APPENDIX C
ASSESSMENT WORKSHEET

ASSESSMENT DATE: 1/25/88
 ASSESSMENT ID: RMS-4247
 NASA FMEA #: 05-6IC-MRL-12

NASA DATA:
 BASELINE []
 NEW [X]

SUBSYSTEM: RMS/EPD&C
 MDAC ID: 4247
 ITEM: RESISTOR, R29

LEAD ANALYST: ROBINSON

ASSESSMENT:

	CRITICALITY FLIGHT HDW/FUNC	REDUNDANCY SCREENS			CIL ITEM
		A	B	C	
NASA	[3 / 3]	[N]	[N]	[N]	[] *
IOA	[3 / 3]	[]	[]	[]	[]
COMPARE	[/]	[N]	[N]	[N]	[]

RECOMMENDATIONS: (If different from NASA)

[/] [] [] [] []
 (ADD/DELETE)

* CIL RETENTION RATIONALE: (If applicable)

ADEQUATE []
 INADEQUATE []

REMARKS:

NO ISSUE. THE NASA FMEA ITEM IS THE "READY TO LATCH INDICATION CIRCUIT" WITH THE FAILURE MODE AS "ERRONEOUS INDICATION". THE IOA FMEAs ADDRESS THE INDIVIDUAL COMPONENTS. FOR COMPARISON PURPOSES, IOA RECOMMENDS COMBINING THE FOLLOWING IOA FMEAs: 4213 THRU 4216, 4247 THRU 4750, 4269 THRU 4272, 4291 THRU 4294, 4313 THRU 4316, AND 4335 THRU 4338.

APPENDIX C
ASSESSMENT WORKSHEET

ASSESSMENT DATE: 1/25/88
 ASSESSMENT ID: RMS-4248
 NASA FMEA #: 05-6IC-MRL-12

NASA DATA:
 BASELINE []
 NEW [X]

SUBSYSTEM: RMS/EPD&C
 MDAC ID: 4248
 ITEM: RESISTOR, R65

LEAD ANALYST: ROBINSON

ASSESSMENT:

	CRITICALITY FLIGHT HDW/FUNC	REDUNDANCY SCREENS			CIL ITEM
		A	B	C	
NASA	[3 / 3]	[N]	[N]	[N]	[] *
IOA	[3 / 3]	[]	[]	[]	[]
COMPARE	[/]	[N]	[N]	[N]	[]

RECOMMENDATIONS: (If different from NASA)

[/] [] [] [] []
 (ADD/DELETE)

* CIL RETENTION RATIONALE: (If applicable)

ADEQUATE []
 INADEQUATE []

REMARKS:

NO ISSUE. THE NASA FMEA ITEM IS THE "READY TO LATCH INDICATION CIRCUIT" WITH THE FAILURE MODE AS "ERRONEOUS INDICATION". THE IOA FMEAs ADDRESS THE INDIVIDUAL COMPONENTS. FOR COMPARISON PURPOSES, IOA RECOMMENDS COMBINING THE FOLLOWING IOA FMEAs: 4213 THRU 4216, 4247 THRU 4750, 4269 THRU 4272, 4291 THRU 4294, 4313 THRU 4316, AND 4335 THRU 4338.

APPENDIX C
ASSESSMENT WORKSHEET

ASSESSMENT DATE: 1/25/88
 ASSESSMENT ID: RMS-4249
 NASA FMEA #: 05-6IC-MRL-12

NASA DATA:
 BASELINE []
 NEW [X]

SUBSYSTEM: RMS/EPD&C
 MDAC ID: 4249
 ITEM: RESISTOR, R28

LEAD ANALYST: ROBINSON

ASSESSMENT:

	CRITICALITY FLIGHT HDW/FUNC	REDUNDANCY SCREENS			CIL ITEM
		A	B	C	
NASA	[3 / 3]	[N]	[N]	[N]	[] *
IOA	[3 / 3]	[]	[]	[]	[]
COMPARE	[/]	[N]	[N]	[N]	[]

RECOMMENDATIONS: (If different from NASA)

[/] [] [] [] []
 (ADD/DELETE)

* CIL RETENTION RATIONALE: (If applicable)

ADEQUATE []
 INADEQUATE []

REMARKS:

NO ISSUE. THE NASA FMEA ITEM IS THE "READY TO LATCH INDICATION CIRCUIT" WITH THE FAILURE MODE AS "ERRONEOUS INDICATION". THE IOA FMEAs ADDRESS THE INDIVIDUAL COMPONENTS. FOR COMPARISON PURPOSES, IOA RECOMMENDS COMBINING THE FOLLOWING IOA FMEAs: 4213 THRU 4216, 4247 THRU 4750, 4269 THRU 4272, 4291 THRU 4294, 4313 THRU 4316, AND 4335 THRU 4338.

APPENDIX C
ASSESSMENT WORKSHEET

ASSESSMENT DATE: 1/30/88
 ASSESSMENT ID: RMS-4251
 NASA FMEA #: 05-6IC-MRL-7

NASA DATA:
 BASELINE []
 NEW [X]

SUBSYSTEM: RMS/EPD&C
 MDAC ID: 4251
 ITEM: RESISTOR, R1

LEAD ANALYST: ROBINSON

ASSESSMENT:

	CRITICALITY FLIGHT HDW/FUNC	REDUNDANCY SCREENS			CIL ITEM
		A	B	C	
NASA	[3 /1R]	[P]	[P]	[P]	[] *
IOA	[3 /2R]	[]	[NA]	[NA]	[]
COMPARE	[/N]	[N]	[N]	[N]	[]

RECOMMENDATIONS: (If different from NASA)

[/] [] [] [] [] (ADD/DELETE)

* CIL RETENTION RATIONALE: (If applicable)

ADEQUATE []
 INADEQUATE []

REMARKS:

IOA CONCURS WITH NASA FMEA. UPGRADE IOA CRIT TO 3/1R AND CORRECT IOA SCREENS. SUBSEQUENT MULTIPLE FAILURES COULD CAUSE MOTOR BURNOUT AND COULD LEAD TO INABILITY TO SAFELY LATCH THE RMS AND SUBSEQUENT FAILURE OF THE GUILLOTINE/JETTISON SYSTEM WHICH COULD CAUSE LOSS OF CREW/VEHICLE. THIS ONE NASA FMEA CORRESPONDS TO THE FOLLOWING 12 IOA FMEAs: 4217, 4218, 4251, 4252, 4273, 4274, 4295, 4296, 4317, 4318, 4339 AND 4340. IOA RECOMMENDS COMBINING ALL LISTED IOA FMEAs INTO ONE TO ALLOW COMPARISON WITH NASA POST 51L FMEA.

APPENDIX C
ASSESSMENT WORKSHEET

ASSESSMENT DATE: 1/30/88
 ASSESSMENT ID: RMS-4252
 NASA FMEA #: 05-6IC-MRL-7

NASA DATA:
 BASELINE []
 NEW [X]

SUBSYSTEM: RMS/EPD&C
 MDAC ID: 4252
 ITEM: RESISTOR, R11

LEAD ANALYST: ROBINSON

ASSESSMENT:

	CRITICALITY FLIGHT HDW/FUNC	REDUNDANCY SCREENS			CIL ITEM
		A	B	C	
NASA	[3 /1R]	[P]	[P]	[P]	[] *
IOA	[3 /2R]	[]	[NA]	[NA]	[]
COMPARE	[/N]	[N]	[N]	[N]	[]

RECOMMENDATIONS: (If different from NASA)

[/] [] [] [] []
 (ADD/DELETE)

* CIL RETENTION RATIONALE: (If applicable)

ADEQUATE []
 INADEQUATE []

REMARKS:

IOA CONCURS WITH NASA FMEA. UPGRADE IOA CRIT TO 3/1R AND CORRECT IOA SCREENS. SUBSEQUENT MULTIPLE FAILURES COULD CAUSE MOTOR BURNOUT AND COULD LEAD TO INABILITY TO SAFELY LATCH THE RMS AND SUBSEQUENT FAILURE OF THE GUILLOTINE/JETTISON SYSTEM WHICH COULD CAUSE LOSS OF CREW/VEHICLE. THIS ONE NASA FMEA CORRESPONDS TO THE FOLLOWING 12 IOA FMEAs: 4217, 4218, 4251, 4252, 4273, 4274, 4295, 4296, 4317, 4318, 4339 AND 4340. IOA RECOMMENDS COMBINING ALL LISTED IOA FMEAs INTO ONE TO ALLOW COMPARISON WITH NASA POST 51L FMEA.

APPENDIX C
ASSESSMENT WORKSHEET

ASSESSMENT DATE: 1/25/88
 ASSESSMENT ID: RMS-4253
 NASA FMEA #: 05-6IC-MRL-11

NASA DATA:
 BASELINE []
 NEW [X]

SUBSYSTEM: RMS/EPD&C
 MDAC ID: 4253
 ITEM: RESISTOR, R25

LEAD ANALYST: ROBINSON

ASSESSMENT:

	CRITICALITY FLIGHT HDW/FUNC	REDUNDANCY SCREENS			CIL ITEM
		A	B	C	
NASA	[3 / 3]	[]	[]	[]	[] *
IOA	[3 / 3]	[]	[]	[]	[]
COMPARE	[/]	[]	[]	[]	[]

RECOMMENDATIONS: (If different from NASA)

[/] [] [] [] []
 (ADD/DELETE)

* CIL RETENTION RATIONALE: (If applicable)

ADEQUATE []
 INADEQUATE []

REMARKS:

NO ISSUE. THE NASA FMEA ITEM IS "INDICATION CIRCUIT - HYBRID DRIVER TYPE 1, RESISTORS & EVENT INDICATION", AND INCLUDES SYSTEM 1 FWD/MID/AFT PEDESTAL CIRCUIT COMPONENTS. FOR COMPARISON, IOA RECOMMENDS COMBINING THE FOLLOWING IOA FMEAs: 4219 THRU 4234, 4253 THRU 4256, 4275 THRU 4278, 4297 THRU 4300, 4319 THRU 4322 AND 4341 THRU 4344. FMEAs WITH 3/3 CRIT DO NOT REQUIRE ASSESSMENT.

APPENDIX C
ASSESSMENT WORKSHEET

ASSESSMENT DATE: 1/25/88
 ASSESSMENT ID: RMS-4254
 NASA FMEA #: 05-6IC-MRL-11

NASA DATA:
 BASELINE []
 NEW [X]

SUBSYSTEM: RMS/EPD&C
 MDAC ID: 4254
 ITEM: RESISTOR, R14

LEAD ANALYST: ROBINSON

ASSESSMENT:

	CRITICALITY FLIGHT HDW/FUNC	REDUNDANCY SCREENS			CIL ITEM
		A	B	C	
NASA	[3 / 3]	[]	[]	[]	[] *
IOA	[3 / 3]	[]	[]	[]	[]
COMPARE	[/]	[]	[]	[]	[]

RECOMMENDATIONS: (If different from NASA)

[/] [] [] [] []
 (ADD/DELETE)

* CIL RETENTION RATIONALE: (If applicable)

ADEQUATE []
 INADEQUATE []

REMARKS:

NO ISSUE. THE NASA FMEA ITEM IS "INDICATION CIRCUIT - HYBRID DRIVER TYPE 1, RESISTORS & EVENT INDICATION", AND INCLUDES SYSTEM 1 FWD/MID/AFT PEDESTAL CIRCUIT COMPONENTS. FOR COMPARISON, IOA RECOMMENDS COMBINING THE FOLLOWING IOA FMEAs: 4219 THRU 4234, 4253 THRU 4256, 4275 THRU 4278, 4297 THRU 4300, 4319 THRU 4322 AND 4341 THRU 4344. FMEAs WITH 3/3 CRIT DO NOT REQUIRE ASSESSMENT.

APPENDIX C
ASSESSMENT WORKSHEET

ASSESSMENT DATE: 1/25/88
 ASSESSMENT ID: RMS-4255
 NASA FMEA #: 05-6IC-MRL-11

NASA DATA:
 BASELINE []
 NEW [X]

SUBSYSTEM: RMS/EPD&C
 MDAC ID: 4255
 ITEM: RESISTOR, R26

LEAD ANALYST: ROBINSON

ASSESSMENT:

	CRITICALITY FLIGHT HDW/FUNC	REDUNDANCY SCREENS			CIL ITEM
		A	B	C	
NASA	[3 / 3]	[]	[]	[]	[] *
IOA	[3 / 3]	[]	[]	[]	[]
COMPARE	[/]	[]	[]	[]	[]

RECOMMENDATIONS: (If different from NASA)

[/] [] [] [] []
 (ADD/DELETE)

* CIL RETENTION RATIONALE: (If applicable)

ADEQUATE []
 INADEQUATE []

REMARKS:

NO ISSUE. THE NASA FMEA ITEM IS "INDICATION CIRCUIT - HYBRID DRIVER TYPE 1, RESISTORS & EVENT INDICATION", AND INCLUDES SYSTEM 1 FWD/MID/AFT PEDESTAL CIRCUIT COMPONENTS. FOR COMPARISON, IOA RECOMMENDS COMBINING THE FOLLOWING IOA FMEAs: 4219 THRU 4234, 4253 THRU 4256, 4275 THRU 4278, 4297 THRU 4300, 4319 THRU 4322 AND 4341 THRU 4344. FMEAs WITH 3/3 CRIT DO NOT REQUIRE ASSESSMENT.

APPENDIX C
ASSESSMENT WORKSHEET

ASSESSMENT DATE: 1/25/88
 ASSESSMENT ID: RMS-4256
 NASA FMEA #: 05-6IC-MRL-11

NASA DATA:
 BASELINE []
 NEW [X]

SUBSYSTEM: RMS/EPD&C
 MDAC ID: 4256
 ITEM: RESISTOR, R15

LEAD ANALYST: ROBINSON

ASSESSMENT:

	CRITICALITY FLIGHT HDW/FUNC	REDUNDANCY SCREENS			CIL ITEM
		A	B	C	
NASA	[3 / 3]	[]	[]	[]	[] *
IOA	[3 / 3]	[]	[]	[]	[]
COMPARE	[/]	[]	[]	[]	[]

RECOMMENDATIONS: (If different from NASA)

[/] [] [] [] []
 (ADD/DELETE)

* CIL RETENTION RATIONALE: (If applicable)

ADEQUATE []
 INADEQUATE []

REMARKS:

NO ISSUE. THE NASA FMEA ITEM IS "INDICATION CIRCUIT - HYBRID DRIVER TYPE 1, RESISTORS & EVENT INDICATION", AND INCLUDES SYSTEM 1 FWD/MID/AFT PEDESTAL CIRCUIT COMPONENTS. FOR COMPARISON, IOA RECOMMENDS COMBINING THE FOLLOWING IOA FMEAs: 4219 THRU 4234, 4253 THRU 4256, 4275 THRU 4278, 4297 THRU 4300, 4319 THRU 4322 AND 4341 THRU 4344. FMEAs WITH 3/3 CRIT DO NOT REQUIRE ASSESSMENT.

APPENDIX C
ASSESSMENT WORKSHEET

ASSESSMENT DATE: 1/24/88
 ASSESSMENT ID: RMS-4257
 NASA FMEA #: 05-6IC-MRL-4

NASA DATA:
 BASELINE []
 NEW [X]

SUBSYSTEM: RMS/EPD&C
 MDAC ID: 4257
 ITEM: HYBRID RELAY, K75

LEAD ANALYST: ROBINSON

ASSESSMENT:

	CRITICALITY FLIGHT HDW/FUNC	REDUNDANCY SCREENS			CIL ITEM
		A	B	C	
NASA	[3 /1R]	[P]	[P]	[P]	[] *
IOA	[3 /2R]	[]	[NA]	[NA]	[]
COMPARE	[/N]	[N]	[N]	[N]	[]

RECOMMENDATIONS: (If different from NASA)

[/] [] [] [] []
 (ADD/DELETE)

* CIL RETENTION RATIONALE: (If applicable)

ADEQUATE []
 INADEQUATE []

REMARKS:

NO ISSUE.

IOA CONCURS WITH THE POST 51L CRIT OF 3/1R. IOA SCREENS SHOULD BE 1-P-P. TO COMPARE WITH THE NASA FMEA, IOA RECOMMENDS COMBINING THE FOLLOWING 24 IOA FMEAs: 4201, 4203, 4205, 4207, 4235, 4237, 4239, 4241, 4257, 4259, 4261, 4263, 4279, 4281, 4283, 4285, 4301, 4303, 4305, 4307, 4323, 4325, 4327, AND 4329. THE IOA FMEAs ARE FOR 12 PORT AND 12 STARBOARD HYBRID RELAYS USED BY SYSTEM 1 AND SYSTEM 2, FWD, MID, AND AFT LATCH/RELEASE FOR BOTH PORT AND STARBOARD ARMS.

APPENDIX C
ASSESSMENT WORKSHEET

ASSESSMENT DATE: 1/30/88
 ASSESSMENT ID: RMS-4258
 NASA FMEA #: 05-6IC-MRL-5

NASA DATA:
 BASELINE []
 NEW [X]

SUBSYSTEM: RMS/EPD&C
 MDAC ID: 4258
 ITEM: HYBRID RELAY, K75

LEAD ANALYST: ROBINSON

ASSESSMENT:

	CRITICALITY FLIGHT HDW/FUNC	REDUNDANCY SCREENS			CIL ITEM
		A	B	C	
NASA	[3 /1R]	[P]	[P]	[P]	[] *
IOA	[3 /2R]	[]	[NA]	[NA]	[]
COMPARE	[/N]	[N]	[N]	[N]	[]

RECOMMENDATIONS: (If different from NASA)

[/] [] [] [] []
 (ADD/DELETE)

* CIL RETENTION RATIONALE: (If applicable)

ADEQUATE []
 INADEQUATE []

REMARKS:

NO ISSUE.
 IOA CONCURS WITH THE POST 51L CRIT OF 3/1R. IOA SCREENS SHOULD BE 1 - P - P. IOA RECOMMENDS COMBINING THE FOLLOWING IOA FMEAs TO COMPARE WITH THE NASA FMEA. COMBINE THE FOLLOWING 12 IOA FMEAs: 4202, 4204, 4236, 4238, 4258, 4260, 4280, 4282, 4302, 4304, THE 12 IOA FMEAs ARE FOR 6 INDIVIDUAL PORT AND 6 INDIVIDUAL STARBOARD HYBRID RELAYS FOR LATCHING.

APPENDIX C
ASSESSMENT WORKSHEET

ASSESSMENT DATE: 1/24/88
 ASSESSMENT ID: RMS-4259
 NASA FMEA #: 05-6IC-MRL-4

NASA DATA:
 BASELINE []
 NEW [X]

SUBSYSTEM: RMS/EPD&C
 MDAC ID: 4259
 ITEM: HYBRID RELAY, K78

LEAD ANALYST: ROBINSON

ASSESSMENT:

	CRITICALITY FLIGHT HDW/FUNC	REDUNDANCY SCREENS			CIL ITEM
		A	B	C	
NASA	[3 /1R]	[P]	[P]	[P]	[] *
IOA	[3 /2R]	[]	[NA]	[NA]	[]
COMPARE	[/N]	[N]	[N]	[N]	[]

RECOMMENDATIONS: (If different from NASA)

[/] [] [] [] []
 (ADD/DELETE)

* CIL RETENTION RATIONALE: (If applicable)

ADEQUATE []
 INADEQUATE []

REMARKS:

NO ISSUE.
 IOA CONCURS WITH THE POST 51L CRIT OF 3/1R. IOA SCREENS SHOULD BE 1-P-P. TO COMPARE WITH THE NASA FMEA, IOA RECOMMENDS COMBINING THE FOLLOWING 24 IOA FMEAs: 4201, 4203, 4205, 4207, 4235, 4237, 4239, 4241, 4257, 4259, 4261, 4263, 4279, 4281, 4283, 4285, 4301, 4303, 4305, 4307, 4323, 4325, 4327, AND 4329. THE IOA FMEAs ARE FOR 12 PORT AND 12 STARBOARD HYBRID RELAYS USED BY SYSTEM 1 AND SYSTEM 2, FWD, MID, AND AFT LATCH/RELEASE FOR BOTH PORT AND STARBOARD ARMS.

APPENDIX C
ASSESSMENT WORKSHEET

ASSESSMENT DATE: 1/30/88
 ASSESSMENT ID: RMS-4260
 NASA FMEA #: 05-6IC-MRL-5

NASA DATA:
 BASELINE []
 NEW [X]

SUBSYSTEM: RMS/EPD&C
 MDAC ID: 4260
 ITEM: HYBRID RELAY, K78

LEAD ANALYST: ROBINSON

ASSESSMENT:

	CRITICALITY FLIGHT HDW/FUNC	REDUNDANCY SCREENS			CIL ITEM
		A	B	C	
NASA	[3 /1R]	[P]	[P]	[P]	[] *
IOA	[3 /2R]	[]	[NA]	[NA]	[]
COMPARE	[/N]	[N]	[N]	[N]	[]

RECOMMENDATIONS: (If different from NASA)

[/] [] [] [] []
 (ADD/DELETE)

* CIL RETENTION RATIONALE: (If applicable)

ADEQUATE []
 INADEQUATE []

REMARKS:

NO ISSUE.

IOA CONCURS WITH THE POST 51L CRIT OF 3/1R. IOA SCREENS SHOULD BE 1 - P - P. IOA RECOMMENDS COMBINING THE FOLLOWING IOA FMEAs TO COMPARE WITH THE NASA FMEA. COMBINE THE FOLLOWING 12 IOA FMEAs: 4202, 4204, 4236, 4238, 4258, 4260, 4280, 4282, 4302, 4304, THE 12 IOA FMEAs ARE FOR 6 INDIVIDUAL PORT AND 6 INDIVIDUAL STARBOARD HYBRID RELAYS FOR LATCHING.

APPENDIX C
ASSESSMENT WORKSHEET

ASSESSMENT DATE: 1/24/88
 ASSESSMENT ID: RMS-4261
 NASA FMEA #: 05-6IC-MRL-4

NASA DATA:
 BASELINE []
 NEW [X]

SUBSYSTEM: RMS/EPD&C
 MDAC ID: 4261
 ITEM: HYBRID RELAY, K73

LEAD ANALYST: ROBINSON

ASSESSMENT:

	CRITICALITY FLIGHT HDW/FUNC	REDUNDANCY SCREENS			CIL ITEM
		A	B	C	
NASA	[3 /1R]	[P]	[P]	[P]	[] *
IOA	[3 /2R]	[]	[NA]	[NA]	[]
COMPARE	[/N]	[N]	[N]	[N]	[]

RECOMMENDATIONS: (If different from NASA)

[/] [] [] [] []
 (ADD/DELETE)

* CIL RETENTION RATIONALE: (If applicable)

ADEQUATE []
 INADEQUATE []

REMARKS:

NO ISSUE.
 IOA CONCURS WITH THE POST 51L CRIT OF 3/1R. IOA SCREENS SHOULD BE 1-P-P. TO COMPARE WITH THE NASA FMEA, IOA RECOMMENDS COMBINING THE FOLLOWING 24 IOA FMEAs: 4201, 4203, 4205, 4207, 4235, 4237, 4239, 4241, 4257, 4259, 4261, 4263, 4279, 4281, 4283, 4285, 4301, 4303, 4305, 4307, 4323, 4325, 4327, AND 4329. THE IOA FMEAs ARE FOR 12 PORT AND 12 STARBOARD HYBRID RELAYS USED BY SYSTEM 1 AND SYSTEM 2, FWD, MID, AND AFT LATCH/RELEASE FOR BOTH PORT AND STARBOARD ARMS.

APPENDIX C
ASSESSMENT WORKSHEET

ASSESSMENT DATE: 2/16/88
 ASSESSMENT ID: RMS-4262
 NASA FMEA #: 05-6IC-MRL-6

NASA DATA:
 BASELINE []
 NEW [X]

SUBSYSTEM: RMS/EPD&C
 MDAC ID: 4262
 ITEM: HYBRID RELAY, K73

LEAD ANALYST: ROBINSON

ASSESSMENT:

	CRITICALITY FLIGHT HDW/FUNC	REDUNDANCY SCREENS			CIL ITEM
		A	B	C	
NASA	[2 /1R]	[P]	[F]	[P]	[X] *
IOA	[3 /2R]	[]	[NA]	[NA]	[]
COMPARE	[N /N]	[N]	[N]	[N]	[N]

RECOMMENDATIONS: (If different from NASA)

[/] [] [] [] []
 (ADD/DELETE)

* CIL RETENTION RATIONALE: (If applicable)

ADEQUATE []
 INADEQUATE []

REMARKS:

NO ISSUE.

IOA CONCURS WITH THE POST 51L CRIT OF 3/1R. IOA SCREENS SHOULD BE 1 - P - P. IOA RECOMMENDS COMBINING THE FOLLOWING IOA FMEAS TO COMPARE WITH THE NASA FMEA. COMBINE THE FOLLOWING 6 IOA FMEAs: 4206, 4208, 4240, 4242, 4262, 4264, 4284, 4286, 4306, THE 12 IOA FMEAs ARE FOR 6 INDIVIDUAL PORT AND 6 INDIVIDUAL STARBOARD HYBRID RELAYS FOR RELEASING.

APPENDIX C
ASSESSMENT WORKSHEET

ASSESSMENT DATE: 1/24/88
 ASSESSMENT ID: RMS-4263
 NASA FMEA #: 05-6IC-MRL-4

NASA DATA:
 BASELINE []
 NEW [X]

SUBSYSTEM: RMS/EPD&C
 MDAC ID: 4263
 ITEM: HYBRID RELAY, K76

LEAD ANALYST: ROBINSON

ASSESSMENT:

	CRITICALITY FLIGHT HDW/FUNC	REDUNDANCY SCREENS			CIL ITEM
		A	B	C	
NASA	[3 /1R]	[P]	[P]	[P]	[] *
IOA	[3 /2R]	[]	[NA]	[NA]	[]
COMPARE	[/N]	[N]	[N]	[N]	[]

RECOMMENDATIONS: (If different from NASA)

[/] [] [] [] []
 (ADD/DELETE)

* CIL RETENTION RATIONALE: (If applicable)

ADEQUATE []
 INADEQUATE []

REMARKS:

NO ISSUE.
 IOA CONCURS WITH THE POST 51L CRIT OF 3/1R. IOA SCREENS SHOULD BE 1-P-P. TO COMPARE WITH THE NASA FMEA, IOA RECOMMENDS COMBINING THE FOLLOWING 24 IOA FMEAs: 4201, 4203, 4205, 4207, 4235, 4237, 4239, 4241, 4257, 4259, 4261, 4263, 4279, 4281, 4283, 4285, 4301, 4303, 4305, 4307, 4323, 4325, 4327, AND 4329. THE IOA FMEAs ARE FOR 12 PORT AND 12 STARBOARD HYBRID RELAYS USED BY SYSTEM 1 AND SYSTEM 2, FWD, MID, AND AFT LATCH/RELEASE FOR BOTH PORT AND STARBOARD ARMS.

APPENDIX C
ASSESSMENT WORKSHEET

ASSESSMENT DATE: 2/16/88
 ASSESSMENT ID: RMS-4264
 NASA FMEA #: 05-6IC-MRL-6

NASA DATA:
 BASELINE []
 NEW [X]

SUBSYSTEM: RMS/EPD&C
 MDAC ID: 4264
 ITEM: HYBRID RELAY, K76

LEAD ANALYST: ROBINSON

ASSESSMENT:

	CRITICALITY FLIGHT HDW/FUNC	REDUNDANCY SCREENS			CIL ITEM
		A	B	C	
NASA	[2 /1R]	[P]	[F]	[P]	[X] *
IOA	[3 /2R]	[]	[NA]	[NA]	[]
COMPARE	[N /N]	[N]	[N]	[N]	[N]

RECOMMENDATIONS: (If different from NASA)

[/] [] [] [] []
 (ADD/DELETE)

* CIL RETENTION RATIONALE: (If applicable)

ADEQUATE []
 INADEQUATE []

REMARKS:

NO ISSUE.

IOA CONCURS WITH THE POST 51L CRIT OF 3/1R. IOA SCREENS SHOULD BE 1 - P - P. IOA RECOMMENDS COMBINING THE FOLLOWING IOA FMEAS TO COMPARE WITH THE NASA FMEA. COMBINE THE FOLLOWING 6 IOA FMEAS: 4206, 4208, 4240, 4242, 4262, 4264, 4284, 4286, 4306, THE 12 IOA FMEAS ARE FOR 6 INDIVIDUAL PORT AND 6 INDIVIDUAL STARBOARD HYBRID RELAYS FOR RELEASING.

APPENDIX C
ASSESSMENT WORKSHEET

ASSESSMENT DATE: 2/14/88
 ASSESSMENT ID: RMS-4265
 NASA FMEA #: 05-6ID-2126-1

NASA DATA:
 BASELINE []
 NEW [X]

SUBSYSTEM: RMS/EPD&C
 MDAC ID: 4265
 ITEM: RELAY, K77

LEAD ANALYST: ROBINSON

ASSESSMENT:

	CRITICALITY FLIGHT HDW/FUNC	REDUNDANCY SCREENS			CIL ITEM
		A	B	C	
NASA	[2 /1R]	[P]	[P]	[P]	[X] *
IOA	[3 /2R]	[]	[NA]	[NA]	[]
COMPARE	[N /N]	[N]	[N]	[N]	[N]

RECOMMENDATIONS: (If different from NASA)

[/] [] [] [P] []
 (ADD/DELETE)

* CIL RETENTION RATIONALE: (If applicable)

ADEQUATE []
 INADEQUATE []

REMARKS:

NO ISSUE. RECOMMEND UPGRADING IOA FMEA TO CRITICALITY 2/1R.
 THE IOA FMEA FOR FAILURE OF THESE RELAYS WAS GENERATED AS PART OF
 THE MANIPULATOR RETENTION LATCH CONTROL CIRCUIT WHICH IS 05-6IC
 SET OF NASA FMEAS ALSO AND THEREFORE THE RESULT OF THE FAILURES
 DO NOT MATCH WHEN COMPARED. THE RELAYS ARE 4 POLE, 2
 POSITION LATCHING RELAYS AND APPEAR IN BOTH THE LATCH CONTROL AND
 THE JETTISON/GUILLOTINE CIRCUITS. IOA CONCURS WITH THE NASA
 FAILURE.

APPENDIX C
ASSESSMENT WORKSHEET

ASSESSMENT DATE: 2/14/88
 ASSESSMENT ID: RMS-4266
 NASA FMEA #: 05-6ID-2129-1

NASA DATA:
 BASELINE [X]
 NEW []

SUBSYSTEM: RMS/EPD&C
 MDAC ID: 4266
 ITEM: RELAY, K11

LEAD ANALYST: ROBINSON

ASSESSMENT:

	CRITICALITY FLIGHT HDW/FUNC	REDUNDANCY SCREENS			CIL ITEM
		A	B	C	
NASA	[3 /3]	[P]	[P]	[P]	[] *
IOA	[3 /2R]	[P]	[NA]	[NA]	[]
COMPARE	[/N]	[]	[N]	[N]	[]

RECOMMENDATIONS: (If different from NASA)

[3 /2R] [] [] [P] []
 (ADD/DELETE)

* CIL RETENTION RATIONALE: (If applicable)

ADEQUATE []
 INADEQUATE []

REMARKS:

RECOMMEND UPGRADING THE NASA FMEA TO 3/2R. RECOMMEND COMBINING COMPONENTS IN IOA FMEAs 4266 AND 4332. THE IOA FMEA FOR FAILURE OF THESE RELAYS WAS GENERATED AS PART OF THE MANIPULATOR RETENTION LATCH CONTROL CIRCUIT WHICH IS 05-6IC SET OF NASA FMEAS ALSO AND THEREFORE THE RESULT OF THE FAILURES DO NOT MATCH WHEN COMPARED. THE RELAYS ARE 4 POLE, 2 POSITION LATCHING RELAYS AND APPEAR IN BOTH THE LATCH CONTROL AND THE JETTISON/GUILLOTINE CIRCUITS. IOA CONCURS WITH THE NASA FAILURE.

APPENDIX C
ASSESSMENT WORKSHEET

ASSESSMENT DATE: 1/30/88
 ASSESSMENT ID: RMS-4267
 NASA FMEA #: 05-6IC-MRL-7A

NASA DATA:
 BASELINE []
 NEW [X]

SUBSYSTEM: RMS/EPD&C
 MDAC ID: 4267
 ITEM: FUSE, F8

LEAD ANALYST: ROBINSON

ASSESSMENT:

	CRITICALITY FLIGHT HDW/FUNC	REDUNDANCY SCREENS			CIL ITEM
		A	B	C	
NASA	[3 /1R]	[P]	[P]	[P]	[] *
IOA	[3 /3]	[]	[]	[]	[]
COMPARE	[/N]	[N]	[N]	[N]	[]

RECOMMENDATIONS: (If different from NASA)

[/] [] [] [] []
 (ADD/DELETE)

* CIL RETENTION RATIONALE: (If applicable)

ADEQUATE []
 INADEQUATE []

REMARKS:

UPGRADE IOA CRIT TO 3/1R AND CORRECT IOA SCREENS. SUBSEQUENT MULTIPLE FAILURES COULD CAUSE MOTOR BURNOUT AND COULD LEAD TO INABILITY TO SAFELY LATCH THE RMS AND SUBSEQUENT FAILURE OF THE GUILLOTINE/JETTISON SYSTEM
 COULD RESULT IN LOSS OF CREW/VEHICLE. THIS ONE NASA FMEA CORRESPONDS TO THE FOLLOWING IOA FMEAs: 4211, 4212, 4245, 4246, 4267, 4268, 4289, 4290, 4311, 4312, 4333, AND 4334. IOA RECOMMENDS COMBINING ALL LISTED IOA FMEAs INTO ONE TO ALLOW COMPARISON WITH THE NASA POST 51L FMEA.

APPENDIX C
ASSESSMENT WORKSHEET

ASSESSMENT DATE: 1/30/88
 ASSESSMENT ID: RMS-4268
 NASA FMEA #: 05-6IC-MRL-7A

NASA DATA:
 BASELINE []
 NEW [X]

SUBSYSTEM: RMS/EPD&C
 MDAC ID: 4268
 ITEM: FUSE, F2

LEAD ANALYST: ROBINSON

ASSESSMENT:

	CRITICALITY FLIGHT HDW/FUNC	REDUNDANCY SCREENS			CIL ITEM
		A	B	C	
NASA	[3 /1R]	[P]	[P]	[P]	[] *
IOA	[3 /3]	[]	[]	[]	[]
COMPARE	[/N]	[N]	[N]	[N]	[]

RECOMMENDATIONS: (If different from NASA)

[/] [] [] [] []
 (ADD/DELETE)

* CIL RETENTION RATIONALE: (If applicable)

ADEQUATE []
 INADEQUATE []

REMARKS:

UPGRADE IOA CRIT TO 3/1R AND CORRECT IOA SCREENS. SUBSEQUENT MULTIPLE FAILURES COULD CAUSE MOTOR BURNOUT AND COULD LEAD TO INABILITY TO SAFELY LATCH THE RMS AND SUBSEQUENT FAILURE OF THE GUILLOTINE/JETTISON SYSTEM COULD RESULT IN LOSS OF CREW/VEHICLE. THIS ONE NASA FMEA CORRESPONDS TO THE FOLLOWING IOA FMEAs: 4211, 4212, 4245, 4246, 4267, 4268, 4289, 4290, 4311, 4312, 4333, AND 4334. IOA RECOMMENDS COMBINING ALL LISTED IOA FMEAs INTO ONE TO ALLOW COMPARISON WITH THE NASA POST 51L FMEA.

APPENDIX C
ASSESSMENT WORKSHEET

ASSESSMENT DATE: 1/25/88
 ASSESSMENT ID: RMS-4269
 NASA FMEA #: 05-6IC-MRL-12

NASA DATA:
 BASELINE []
 NEW [X]

SUBSYSTEM: RMS/EPD&C
 MDAC ID: 4269
 ITEM: RESISTOR, R61

LEAD ANALYST: ROBINSON

ASSESSMENT:

	CRITICALITY FLIGHT HDW/FUNC	REDUNDANCY SCREENS			CIL ITEM
		A	B	C	
NASA	[3 / 3]	[N]	[N]	[N]	[] *
IOA	[3 / 3]	[]	[]	[]	[]
COMPARE	[/]	[N]	[N]	[N]	[]

RECOMMENDATIONS: (If different from NASA)

[/] [] [] [] []
 (ADD/DELETE)

* CIL RETENTION RATIONALE: (If applicable)

ADEQUATE []
 INADEQUATE []

REMARKS:

NO ISSUE. THE NASA FMEA ITEM IS THE "READY TO LATCH INDICATION CIRCUIT" WITH THE FAILURE MODE AS "ERRONEOUS INDICATION". THE IOA FMEAs ADDRESS THE INDIVIDUAL COMPONENTS. FOR COMPARISON PURPOSES, IOA RECOMMENDS COMBINING THE FOLLOWING IOA FMEAs: 4213 THRU 4216, 4247 THRU 4750, 4269 THRU 4272, 4291 THRU 4294, 4313 THRU 4316, AND 4335 THRU 4338.

APPENDIX C
ASSESSMENT WORKSHEET

ASSESSMENT DATE: 1/25/88
 ASSESSMENT ID: RMS-4270
 NASA FMEA #: 05-6IC-MRL-12

NASA DATA:
 BASELINE []
 NEW [X]

SUBSYSTEM: RMS/EPD&C
 MDAC ID: 4270
 ITEM: RESISTOR, R41

LEAD ANALYST: ROBINSON

ASSESSMENT:

	CRITICALITY FLIGHT HDW/FUNC	REDUNDANCY SCREENS			CIL ITEM
		A	B	C	
NASA	[3 / 3]	[N]	[N]	[N]	[] *
IOA	[3 / 3]	[]	[]	[]	[]
COMPARE	[/]	[N]	[N]	[N]	[]

RECOMMENDATIONS: (If different from NASA)

[/] [] [] [] []
 (ADD/DELETE)

* CIL RETENTION RATIONALE: (If applicable)

ADEQUATE []
 INADEQUATE []

REMARKS:

NO ISSUE. THE NASA FMEA ITEM IS THE "READY TO LATCH INDICATION CIRCUIT" WITH THE FAILURE MODE AS "ERRONEOUS INDICATION". THE IOA FMEAs ADDRESS THE INDIVIDUAL COMPONENTS. FOR COMPARISON PURPOSES, IOA RECOMMENDS COMBINING THE FOLLOWING IOA FMEAs: 4213 THRU 4216, 4247 THRU 4750, 4269 THRU 4272, 4291 THRU 4294, 4313 THRU 4316, AND 4335 THRU 4338.

APPENDIX C
ASSESSMENT WORKSHEET

ASSESSMENT DATE: 1/25/88
 ASSESSMENT ID: RMS-4271
 NASA FMEA #: 05-6IC-MRL-12

NASA DATA:
 BASELINE []
 NEW [X]

SUBSYSTEM: RMS/EPD&C
 MDAC ID: 4271
 ITEM: RESISTOR, R62

LEAD ANALYST: ROBINSON

ASSESSMENT:

	CRITICALITY FLIGHT HDW/FUNC	REDUNDANCY SCREENS			CIL ITEM
		A	B	C	
NASA	[3 / 3]	[N]	[N]	[N]	[] *
IOA	[3 / 3]	[]	[]	[]	[]
COMPARE	[/]	[N]	[N]	[N]	[]

RECOMMENDATIONS: (If different from NASA)

[/] [] [] [] []
 (ADD/DELETE)

* CIL RETENTION RATIONALE: (If applicable)

ADEQUATE []
 INADEQUATE []

REMARKS:

NO ISSUE. THE NASA FMEA ITEM IS THE "READY TO LATCH INDICATION CIRCUIT" WITH THE FAILURE MODE AS "ERRONEOUS INDICATION". THE IOA FMEAs ADDRESS THE INDIVIDUAL COMPONENTS. FOR COMPARISON PURPOSES, IOA RECOMMENDS COMBINING THE FOLLOWING IOA FMEAs: 4213 THRU 4216, 4247 THRU 4750, 4269 THRU 4272, 4291 THRU 4294, 4313 THRU 4316, AND 4335 THRU 4338.

APPENDIX C
ASSESSMENT WORKSHEET

ASSESSMENT DATE: 1/25/88
 ASSESSMENT ID: RMS-4272
 NASA FMEA #: 05-6IC-MRL-12

NASA DATA:
 BASELINE []
 NEW [X]

SUBSYSTEM: RMS/EPD&C
 MDAC ID: 4272
 ITEM: RESISTOR, R40

LEAD ANALYST: ROBINSON

ASSESSMENT:

	CRITICALITY FLIGHT HDW/FUNC	REDUNDANCY SCREENS			CIL ITEM
		A	B	C	
NASA	[3 / 3]	[N]	[N]	[N]	[] *
IOA	[3 / 3]	[]	[]	[]	[]
COMPARE	[/]	[N]	[N]	[N]	[]

RECOMMENDATIONS: (If different from NASA)

[/] [] [] [] []
 (ADD/DELETE)

* CIL RETENTION RATIONALE: (If applicable)

ADEQUATE []
 INADEQUATE []

REMARKS:

NO ISSUE. THE NASA FMEA ITEM IS THE "READY TO LATCH INDICATION CIRCUIT" WITH THE FAILURE MODE AS "ERRONEOUS INDICATION". THE IOA FMEAs ADDRESS THE INDIVIDUAL COMPONENTS. FOR COMPARISON PURPOSES, IOA RECOMMENDS COMBINING THE FOLLOWING IOA FMEAs: 4213 THRU 4216, 4247 THRU 4750, 4269 THRU 4272, 4291 THRU 4294, 4313 THRU 4316, AND 4335 THRU 4338.

APPENDIX C
ASSESSMENT WORKSHEET

ASSESSMENT DATE: 1/30/88
 ASSESSMENT ID: RMS-4273
 NASA FMEA #: 05-6IC-MRL-7

NASA DATA:
 BASELINE []
 NEW [X]

SUBSYSTEM: RMS/EPD&C
 MDAC ID: 4273
 ITEM: RESISTOR, R14

LEAD ANALYST: ROBINSON

ASSESSMENT:

	CRITICALITY FLIGHT HDW/FUNC	REDUNDANCY SCREENS			CIL ITEM
		A	B	C	
NASA	[3 /1R]	[P]	[P]	[P]	[] *
IOA	[3 /2R]	[]	[NA]	[NA]	[]
COMPARE	[/N]	[N]	[N]	[N]	[]

RECOMMENDATIONS: (If different from NASA)

[/] [] [] [] []
 (ADD/DELETE)

* CIL RETENTION RATIONALE: (If applicable)

ADEQUATE []
 INADEQUATE []

REMARKS:

IOA CONCURS WITH NASA FMEA. UPGRADE IOA CRIT TO 3/1R AND CORRECT IOA SCREENS. SUBSEQUENT MULTIPLE FAILURES COULD CAUSE MOTOR BURNOUT AND COULD LEAD TO INABILITY TO SAFELY LATCH THE RMS AND SUBSEQUENT FAILURE OF THE GUILLOTINE/JETTISON SYSTEM WHICH COULD CAUSE LOSS OF CREW/VEHICLE. THIS ONE NASA FMEA CORRESPONDS TO THE FOLLOWING 12 IOA FMEAs: 4217, 4218, 4251, 4252, 4273, 4274, 4295, 4296, 4317, 4318, 4339 AND 4340. IOA RECOMMENDS COMBINING ALL LISTED IOA FMEAs INTO ONE TO ALLOW COMPARISON WITH NASA POST 51L FMEA.

APPENDIX C
ASSESSMENT WORKSHEET

ASSESSMENT DATE: 1/30/88
 ASSESSMENT ID: RMS-4274
 NASA FMEA #: 05-6IC-MRL-7

NASA DATA:
 BASELINE []
 NEW [X]

SUBSYSTEM: RMS/EPD&C
 MDAC ID: 4274
 ITEM: RESISTOR, R2

LEAD ANALYST: ROBINSON

ASSESSMENT:

	CRITICALITY FLIGHT HDW/FUNC	REDUNDANCY SCREENS			CIL ITEM
		A	B	C	
NASA	[3 /1R]	[P]	[P]	[P]	[] *
IOA	[3 /2R]	[]	[NA]	[NA]	[]
COMPARE	[/N]	[N]	[N]	[N]	[]

RECOMMENDATIONS: (If different from NASA)

[/] [] [] [] []
 (ADD/DELETE)

* CIL RETENTION RATIONALE: (If applicable)

ADEQUATE []
 INADEQUATE []

REMARKS:

IOA CONCURS WITH NASA FMEA. UPGRADE IOA CRIT TO 3/1R AND CORRECT IOA SCREENS. SUBSEQUENT MULTIPLE FAILURES COULD CAUSE MOTOR BURNOUT AND COULD LEAD TO INABILITY TO SAFELY LATCH THE RMS AND SUBSEQUENT FAILURE OF THE GUILLOTINE/JETTISON SYSTEM WHICH COULD CAUSE LOSS OF CREW/VEHICLE. THIS ONE NASA FMEA CORRESPONDS TO THE FOLLOWING 12 IOA FMEAs: 4217, 4218, 4251, 4252, 4273, 4274, 4295, 4296, 4317, 4318, 4339 AND 4340. IOA RECOMMENDS COMBINING ALL LISTED IOA FMEAs INTO ONE TO ALLOW COMPARISON WITH NASA POST 51L FMEA.

APPENDIX C
ASSESSMENT WORKSHEET

ASSESSMENT DATE: 1/25/88
 ASSESSMENT ID: RMS-4275
 NASA FMEA #: 05-6IC-MRL-11

NASA DATA:
 BASELINE []
 NEW [X]

SUBSYSTEM: RMS/EPD&C
 MDAC ID: 4275
 ITEM: RESISTOR, R59

LEAD ANALYST: ROBINSON

ASSESSMENT:

	CRITICALITY FLIGHT HDW/FUNC	REDUNDANCY SCREENS			CIL ITEM
		A	B	C	
NASA	[3 / 3]	[]	[]	[]	[] *
IOA	[3 / 3]	[]	[]	[]	[]
COMPARE	[/]	[]	[]	[]	[]

RECOMMENDATIONS: (If different from NASA)

[/] [] [] [] []
 (ADD/DELETE)

* CIL RETENTION RATIONALE: (If applicable)

ADEQUATE []
 INADEQUATE []

REMARKS:

NO ISSUE. THE NASA FMEA ITEM IS "INDICATION CIRCUIT - HYBRID DRIVER TYPE 1, RESISTORS & EVENT INDICATION", AND INCLUDES SYSTEM 1 FWD/MID/AFT PEDESTAL CIRCUIT COMPONENTS. FOR COMPARISON, IOA RECOMMENDS COMBINING THE FOLLOWING IOA FMEAs: 4219 THRU 4234, 4253 THRU 4256, 4275 THRU 4278, 4297 THRU 4300, 4319 THRU 4322 AND 4341 THRU 4344. FMEAs WITH 3/3 CRIT DO NOT REQUIRE ASSESSMENT.

APPENDIX C
ASSESSMENT WORKSHEET

ASSESSMENT DATE: 1/25/88
 ASSESSMENT ID: RMS-4276
 NASA FMEA #: 05-6IC-MRL-11

NASA DATA:
 BASELINE []
 NEW [X]

SUBSYSTEM: RMS/EPD&C
 MDAC ID: 4276
 ITEM: RESISTOR, R31

LEAD ANALYST: ROBINSON

ASSESSMENT:

	CRITICALITY FLIGHT HDW/FUNC	REDUNDANCY SCREENS			CIL ITEM
		A	B	C	
NASA	[3 / 3]	[]	[]	[]	[] *
IOA	[3 / 3]	[]	[]	[]	[]
COMPARE	[/]	[]	[]	[]	[]

RECOMMENDATIONS: (If different from NASA)

[/] [] [] [] []
 (ADD/DELETE)

* CIL RETENTION RATIONALE: (If applicable)

ADEQUATE []
 INADEQUATE []

REMARKS:

NO ISSUE. THE NASA FMEA ITEM IS "INDICATION CIRCUIT - HYBRID DRIVER TYPE 1, RESISTORS & EVENT INDICATION", AND INCLUDES SYSTEM 1 FWD/MID/AFT PEDESTAL CIRCUIT COMPONENTS. FOR COMPARISON, IOA RECOMMENDS COMBINING THE FOLLOWING IOA FMEAs: 4219 THRU 4234, 4253 THRU 4256, 4275 THRU 4278, 4297 THRU 4300, 4319 THRU 4322 AND 4341 THRU 4344. FMEAs WITH 3/3 CRIT DO NOT REQUIRE ASSESSMENT.

APPENDIX C
ASSESSMENT WORKSHEET

ASSESSMENT DATE: 1/25/88
 ASSESSMENT ID: RMS-4277
 NASA FMEA #: 05-6IC-MRL-11

NASA DATA:
 BASELINE []
 NEW [X]

SUBSYSTEM: RMS/EPD&C
 MDAC ID: 4277
 ITEM: RESISTOR, R60

LEAD ANALYST: ROBINSON

ASSESSMENT:

	CRITICALITY FLIGHT HDW/FUNC	REDUNDANCY SCREENS			CIL ITEM
		A	B	C	
NASA	[3 / 3]	[]	[]	[]	[] *
IOA	[3 / 3]	[]	[]	[]	[]
COMPARE	[/]	[]	[]	[]	[]

RECOMMENDATIONS: (If different from NASA)

[/] [] [] [] []
 (ADD/DELETE)

* CIL RETENTION RATIONALE: (If applicable)

ADEQUATE []
 INADEQUATE []

REMARKS:

NO ISSUE. THE NASA FMEA ITEM IS "INDICATION CIRCUIT - HYBRID DRIVER TYPE 1, RESISTORS & EVENT INDICATION", AND INCLUDES SYSTEM 1 FWD/MID/AFT PEDESTAL CIRCUIT COMPONENTS. FOR COMPARISON, IOA RECOMMENDS COMBINING THE FOLLOWING IOA FMEAs: 4219 THRU 4234, 4253 THRU 4256, 4275 THRU 4278, 4297 THRU 4300, 4319 THRU 4322 AND 4341 THRU 4344. FMEAs WITH 3/3 CRIT DO NOT REQUIRE ASSESSMENT.

APPENDIX C
ASSESSMENT WORKSHEET

ASSESSMENT DATE: 1/25/88
 ASSESSMENT ID: RMS-4278
 NASA FMEA #: 05-6IC-MRL-11

NASA DATA:
 BASELINE []
 NEW [X]

SUBSYSTEM: RMS/EPD&C
 MDAC ID: 4278
 ITEM: RESISTOR, R33

LEAD ANALYST: ROBINSON

ASSESSMENT:

	CRITICALITY FLIGHT HDW/FUNC	REDUNDANCY SCREENS			CIL ITEM
		A	B	C	
NASA	[3 / 3]	[]	[]	[]	[] *
IOA	[3 / 3]	[]	[]	[]	[]
COMPARE	[/]	[]	[]	[]	[]

RECOMMENDATIONS: (If different from NASA)

[/] [] [] [] []
 (ADD/DELETE)

* CIL RETENTION RATIONALE: (If applicable)

ADEQUATE []
 INADEQUATE []

REMARKS:

NO ISSUE. THE NASA FMEA ITEM IS "INDICATION CIRCUIT - HYBRID DRIVER TYPE 1, RESISTORS & EVENT INDICATION", AND INCLUDES SYSTEM 1 FWD/MID/AFT PEDESTAL CIRCUIT COMPONENTS. FOR COMPARISON, IOA RECOMMENDS COMBINING THE FOLLOWING IOA FMEAs: 4219 THRU 4234, 4253 THRU 4256, 4275 THRU 4278, 4297 THRU 4300, 4319 THRU 4322 AND 4341 THRU 4344. FMEAs WITH 3/3 CRIT DO NOT REQUIRE ASSESSMENT.

APPENDIX C
ASSESSMENT WORKSHEET

ASSESSMENT DATE: 1/24/88
 ASSESSMENT ID: RMS-4279
 NASA FMEA #: 05-6IC-MRL-4

NASA DATA:
 BASELINE []
 NEW [X]

SUBSYSTEM: RMS/EPD&C
 MDAC ID: 4279
 ITEM: HYBRID RELAY, K54

LEAD ANALYST: ROBINSON

ASSESSMENT:

	CRITICALITY FLIGHT HDW/FUNC	REDUNDANCY SCREENS			CIL ITEM
		A	B	C	
NASA	[3 /1R]	[P]	[P]	[P]	[] *
IOA	[3 /2R]	[]	[NA]	[NA]	[]
COMPARE	[/N]	[N]	[N]	[N]	[]

RECOMMENDATIONS: (If different from NASA)

[/] [] [] [] []
 (ADD/DELETE)

* CIL RETENTION RATIONALE: (If applicable)

ADEQUATE []
 INADEQUATE []

REMARKS:

NO ISSUE.
 IOA CONCURS WITH THE POST 51L CRIT OF 3/1R. IOA SCREENS SHOULD BE 1-P-P. TO COMPARE WITH THE NASA FMEA, IOA RECOMMENDS COMBINING THE FOLLOWING 24 IOA FMEAs: 4201, 4203, 4205, 4207, 4235, 4237, 4239, 4241, 4257, 4259, 4261, 4263, 4279, 4281, 4283, 4285, 4301, 4303, 4305, 4307, 4323, 4325, 4327, AND 4329. THE IOA FMEAs ARE FOR 12 PORT AND 12 STARBOARD HYBRID RELAYS USED BY SYSTEM 1 AND SYSTEM 2, FWD, MID, AND AFT LATCH/RELEASE FOR BOTH PORT AND STARBOARD ARMS.

APPENDIX C
ASSESSMENT WORKSHEET

ASSESSMENT DATE: 1/30/88
 ASSESSMENT ID: RMS-4280
 NASA FMEA #: 05-6IC-MRL-5

NASA DATA:
 BASELINE []
 NEW [X]

SUBSYSTEM: RMS/EPD&C
 MDAC ID: 4280
 ITEM: HYBRID RELAY, K54

LEAD ANALYST: ROBINSON

ASSESSMENT:

	CRITICALITY FLIGHT HDW/FUNC	REDUNDANCY SCREENS			CIL ITEM
		A	B	C	
NASA	[3 /1R]	[P]	[P]	[P]	[] *
IOA	[3 /2R]	[]	[NA]	[NA]	[]
COMPARE	[/N]	[N]	[N]	[N]	[N]

RECOMMENDATIONS: (If different from NASA)

[/] [] [] [] []
 (ADD/DELETE)

* CIL RETENTION RATIONALE: (If applicable)

ADEQUATE []
 INADEQUATE []

REMARKS:

NO ISSUE.

IOA CONCURS WITH THE POST 51L CRIT OF 3/1R. IOA SCREENS SHOULD BE 1 - P - P. IOA RECOMMENDS COMBINING THE FOLLOWING IOA FMEAs TO COMPARE WITH THE NASA FMEA. COMBINE THE FOLLOWING 12 IOA FMEAs: 4202, 4204, 4236, 4238, 4258, 4260, 4280, 4282, 4302, 4304, THE 12 IOA FMEAs ARE FOR 6 INDIVIDUAL PORT AND 6 INDIVIDUAL STARBOARD HYBRID RELAYS FOR LATCHING.

APPENDIX C
ASSESSMENT WORKSHEET

ASSESSMENT DATE: 1/24/88
 ASSESSMENT ID: RMS-4281
 NASA FMEA #: 05-6IC-MRL-4

NASA DATA:
 BASELINE []
 NEW [X]

SUBSYSTEM: RMS/EPD&C
 MDAC ID: 4281
 ITEM: HYBRID RELAY, K56

LEAD ANALYST: ROBINSON

ASSESSMENT:

	CRITICALITY FLIGHT HDW/FUNC	REDUNDANCY SCREENS			CIL ITEM
		A	B	C	
NASA	[3 /1R]	[P]	[P]	[P]	[] *
IOA	[3 /2R]	[]	[NA]	[NA]	[]
COMPARE	[/N]	[N]	[N]	[N]	[]

RECOMMENDATIONS: (If different from NASA)

[/] [] [] [] []
 (ADD/DELETE)

* CIL RETENTION RATIONALE: (If applicable)

ADEQUATE []
 INADEQUATE []

REMARKS:
 NO ISSUE.

IOA CONCURS WITH THE POST 51L CRIT OF 3/1R. IOA SCREENS SHOULD BE 1-P-P. TO COMPARE WITH THE NASA FMEA, IOA RECOMMENDS COMBINING THE FOLLOWING 24 IOA FMEAs: 4201, 4203, 4205, 4207, 4235, 4237, 4239, 4241, 4257, 4259, 4261, 4263, 4279, 4281, 4283, 4285, 4301, 4303, 4305, 4307, 4323, 4325, 4327, AND 4329. THE IOA FMEAs ARE FOR 12 PORT AND 12 STARBOARD HYBRID RELAYS USED BY SYSTEM 1 AND SYSTEM 2, FWD, MID, AND AFT LATCH/RELEASE FOR BOTH PORT AND STARBOARD ARMS.

APPENDIX C
ASSESSMENT WORKSHEET

ASSESSMENT DATE: 1/30/88
 ASSESSMENT ID: RMS-4282
 NASA FMEA #: 05-6IC-MRL-5

NASA DATA:
 BASELINE []
 NEW [X]

SUBSYSTEM: RMS/EPD&C
 MDAC ID: 4282
 ITEM: HYBRID RELAY, K56

LEAD ANALYST: ROBINSON

ASSESSMENT:

	CRITICALITY FLIGHT HDW/FUNC	REDUNDANCY SCREENS			CIL ITEM
		A	B	C	
NASA	[3 /1R]	[P]	[P]	[P]	[] *
IOA	[3 /2R]	[]	[NA]	[NA]	[]
COMPARE	[/N]	[N]	[N]	[N]	[]

RECOMMENDATIONS: (If different from NASA)

[/] [] [] [] []
 (ADD/DELETE)

* CIL RETENTION RATIONALE: (If applicable)

ADEQUATE []
 INADEQUATE []

REMARKS:

NO ISSUE.

IOA CONCURS WITH THE POST 51L CRIT OF 3/1R. IOA SCREENS SHOULD BE 1 - P - P. IOA RECOMMENDS COMBINING THE FOLLOWING IOA FMEAs TO COMPARE WITH THE NASA FMEA. COMBINE THE FOLLOWING 12 IOA FMEAs: 4202, 4204, 4236, 4238, 4258, 4260, 4280, 4282, 4302, 4304, THE 12 IOA FMEAs ARE FOR 6 INDIVIDUAL PORT AND 6 INDIVIDUAL STARBOARD HYBRID RELAYS FOR LATCHING.

APPENDIX C
ASSESSMENT WORKSHEET

ASSESSMENT DATE: 1/24/88
 ASSESSMENT ID: RMS-4283
 NASA FMEA #: 05-6IC-MRL-4

NASA DATA:
 BASELINE []
 NEW [X]

SUBSYSTEM: RMS/EPD&C
 MDAC ID: 4283
 ITEM: HYBRID RELAY, K66

LEAD ANALYST: ROBINSON

ASSESSMENT:

	CRITICALITY FLIGHT HDW/FUNC	REDUNDANCY SCREENS			CIL ITEM
		A	B	C	
NASA	[3 /1R]	[P]	[P]	[P]	[] *
IOA	[3 /2R]	[]	[NA]	[NA]	[]
COMPARE	[/N]	[N]	[N]	[N]	[]

RECOMMENDATIONS: (If different from NASA)

[/] [] [] [] []
 (ADD/DELETE)

* CIL RETENTION RATIONALE: (If applicable)

ADEQUATE []
 INADEQUATE []

REMARKS:

NO ISSUE.
 IOA CONCURS WITH THE POST 51L CRIT OF 3/1R. IOA SCREENS SHOULD BE 1-P-P. TO COMPARE WITH THE NASA FMEA, IOA RECOMMENDS COMBINING THE FOLLOWING 24 IOA FMEAs: 4201, 4203, 4205, 4207, 4235, 4237, 4239, 4241, 4257, 4259, 4261, 4263, 4279, 4281, 4283, 4285, 4301, 4303, 4305, 4307, 4323, 4325, 4327, AND 4329. THE IOA FMEAs ARE FOR 12 PORT AND 12 STARBOARD HYBRID RELAYS USED BY SYSTEM 1 AND SYSTEM 2, FWD, MID, AND AFT LATCH/RELEASE FOR BOTH PORT AND STARBOARD ARMS.

APPENDIX C
ASSESSMENT WORKSHEET

ASSESSMENT DATE: 2/16/88
 ASSESSMENT ID: RMS-4284
 NASA FMEA #: 05-6IC-MRL-6

NASA DATA:
 BASELINE []
 NEW [X]

SUBSYSTEM: RMS/EPD&C
 MDAC ID: 4284
 ITEM: HYBRID RELAY, K66

LEAD ANALYST: ROBINSON

ASSESSMENT:

	CRITICALITY FLIGHT HDW/FUNC	REDUNDANCY SCREENS			CIL ITEM
		A	B	C	
NASA	[2 /1R]	[P]	[F]	[P]	[X] *
IOA	[3 /2R]	[]	[NA]	[NA]	[]
COMPARE	[N /N]	[N]	[N]	[N]	[N]

RECOMMENDATIONS: (If different from NASA)

[/] [] [] [] []
 (ADD/DELETE)

* CIL RETENTION RATIONALE: (If applicable)

ADEQUATE []
 INADEQUATE []

REMARKS:

NO ISSUE.

IOA CONCURS WITH THE POST 51L CRIT OF 3/1R. IOA SCREENS SHOULD BE 1 - P - P. IOA RECOMMENDS COMBINING THE FOLLOWING IOA FMEAS TO COMPARE WITH THE NASA FMEA. COMBINE THE FOLLOWING 6 IOA FMEAs: 4206, 4208, 4240, 4242, 4262, 4264, 4284, 4286, 4306, THE 12 IOA FMEAs ARE FOR 6 INDIVIDUAL PORT AND 6 INDIVIDUAL STARBOARD HYBRID RELAYS FOR RELEASING.

APPENDIX C
ASSESSMENT WORKSHEET

ASSESSMENT DATE: 1/24/88
 ASSESSMENT ID: RMS-4285
 NASA FMEA #: 05-6IC-MRL-4

NASA DATA:
 BASELINE []
 NEW [X]

SUBSYSTEM: RMS/EPD&C
 MDAC ID: 4285
 ITEM: HYBRID RELAY, K44

LEAD ANALYST: ROBINSON

ASSESSMENT:

	CRITICALITY FLIGHT HDW/FUNC	REDUNDANCY SCREENS			CIL ITEM
		A	B	C	
NASA	[3 /1R]	[P]	[P]	[P]	[] *
IOA	[3 /2R]	[]	[NA]	[NA]	[]
COMPARE	[/N]	[N]	[N]	[N]	[]

RECOMMENDATIONS: (If different from NASA)

[/] [] [] [] []
 (ADD/DELETE)

* CIL RETENTION RATIONALE: (If applicable)

ADEQUATE []
 INADEQUATE []

REMARKS:

NO ISSUE.
 IOA CONCURS WITH THE POST 51L CRIT OF 3/1R. IOA SCREENS SHOULD BE 1-P-P. TO COMPARE WITH THE NASA FMEA, IOA RECOMMENDS COMBINING THE FOLLOWING 24 IOA FMEAs: 4201, 4203, 4205, 4207, 4235, 4237, 4239, 4241, 4257, 4259, 4261, 4263, 4279, 4281, 4283, 4285, 4301, 4303, 4305, 4307, 4323, 4325, 4327, AND 4329. THE IOA FMEAs ARE FOR 12 PORT AND 12 STARBOARD HYBRID RELAYS USED BY SYSTEM 1 AND SYSTEM 2, FWD, MID, AND AFT LATCH/RELEASE FOR BOTH PORT AND STARBOARD ARMS.

APPENDIX C
ASSESSMENT WORKSHEET

ASSESSMENT DATE: 2/16/88
 ASSESSMENT ID: RMS-4286
 NASA FMEA #: 05-6IC-MRL-6

NASA DATA:
 BASELINE []
 NEW [X]

SUBSYSTEM: RMS/EPD&C
 MDAC ID: 4286
 ITEM: HYBRID RELAY, K44

LEAD ANALYST: ROBINSON

ASSESSMENT:

	CRITICALITY FLIGHT HDW/FUNC	REDUNDANCY SCREENS			CIL ITEM
		A	B	C	
NASA	[2 /1R]	[P]	[F]	[P]	[X] *
IOA	[3 /2R]	[]	[NA]	[NA]	[]
COMPARE	[N /N]	[N]	[N]	[N]	[N]

RECOMMENDATIONS: (If different from NASA)

[/] [] [] [] []
 (ADD/DELETE)

* CIL RETENTION RATIONALE: (If applicable)

ADEQUATE []
 INADEQUATE []

REMARKS:

NO ISSUE.
 IOA CONCURS WITH THE POST 51L CRIT OF 3/1R. IOA SCREENS SHOULD BE 1 - P - P. IOA RECOMMENDS COMBINING THE FOLLOWING IOA FMEAS TO COMPARE WITH THE NASA FMEA. COMBINE THE FOLLOWING 6 IOA FMEAS: 4206, 4208, 4240, 4242, 4262, 4264, 4284, 4286, 4306, THE 12 IOA FMEAS ARE FOR 6 INDIVIDUAL PORT AND 6 INDIVIDUAL STARBOARD HYBRID RELAYS FOR RELEASING.

APPENDIX C
ASSESSMENT WORKSHEET

ASSESSMENT DATE: 2/14/88
 ASSESSMENT ID: RMS-4287
 NASA FMEA #: 05-6ID-2128-1

NASA DATA:
 BASELINE []
 NEW [X]

SUBSYSTEM: RMS/EPD&C
 MDAC ID: 4287
 ITEM: RELAY, K68

LEAD ANALYST: ROBINSON

ASSESSMENT:

	CRITICALITY FLIGHT HDW/FUNC	REDUNDANCY SCREENS			CIL ITEM
		A	B	C	
NASA	[2 /1R]	[P]	[P]	[P]	[X] *
IOA	[3 /2R]	[]	[NA]	[NA]	[]
COMPARE	[N /N]	[N]	[N]	[N]	[N]

RECOMMENDATIONS: (If different from NASA)

[/] [] [] [P] []
 (ADD/DELETE)

* CIL RETENTION RATIONALE: (If applicable)

ADEQUATE []
 INADEQUATE []

REMARKS:

NO ISSUE. RECOMMEND UPGRADING IOA FMEA TO CRITICALITY 2/1R. THE IOA FMEA FOR FAILURE OF THESE RELAYS WAS GENERATED AS PART OF THE MANIPULATOR RETENTION LATCH CONTROL CIRCUIT WHICH IS 05-6IC SET OF NASA FMEAS ALSO AND THEREFORE THE RESULT OF THE FAILURES DO NOT MATCH WHEN COMPARED. THE RELAYS ARE 4 POLE, 2 POSITION LATCHING RELAYS AND APPEAR IN BOTH THE LATCH CONTROL AND THE JETTISON/GUILLOTINE CIRCUITS. IOA CONCURS WITH THE NASA FAILURE.

APPENDIX C
ASSESSMENT WORKSHEET

ASSESSMENT DATE: 2/14/88
 ASSESSMENT ID: RMS-4288
 NASA FMEA #: 05-6ID-2131-1

NASA DATA:
 BASELINE [X]
 NEW []

SUBSYSTEM: RMS/EPD&C
 MDAC ID: 4288
 ITEM: RELAY, K58

LEAD ANALYST: ROBINSON

ASSESSMENT:

	CRITICALITY FLIGHT HDW/FUNC	REDUNDANCY SCREENS			CIL ITEM
		A	B	C	
NASA	[3 /3]	[P]	[P]	[P]	[] *
IOA	[3 /2R]	[P]	[NA]	[NA]	[]
COMPARE	[/N]	[]	[N]	[N]	[]

RECOMMENDATIONS: (If different from NASA)

[3 /2R] [] [] [P] []
 (ADD/DELETE)

* CIL RETENTION RATIONALE: (If applicable)

ADEQUATE []
 INADEQUATE []

REMARKS:

RECOMMEND UPGRADING THE NASA FMEA TO 3/2R. RECOMMEND COMBINING COMPONENTS IN IOA FMEAs 4210 AND 4288. THE IOA FMEA FOR FAILURE OF THESE RELAYS WAS GENERATED AS PART OF THE MANIPULATOR RETENTION LATCH CONTROL CIRCUIT WHICH IS 05-6IC SET OF NASA FMEAS ALSO AND THEREFORE THE RESULT OF THE FAILURES DO NOT MATCH WHEN COMPARED. THE RELAYS ARE 4 POLE, 2 POSITION LATCHING RELAYS AND APPEAR IN BOTH THE LATCH CONTROL AND THE JETTISON/GUILLOTINE CIRCUITS. IOA CONCURS WITH THE NASA FAILURE.

APPENDIX C
ASSESSMENT WORKSHEET

ASSESSMENT DATE: 1/30/88
 ASSESSMENT ID: RMS-4289
 NASA FMEA #: 05-6IC-MRL-7A

NASA DATA:
 BASELINE []
 NEW [X]

SUBSYSTEM: RMS/EPD&C
 MDAC ID: 4289
 ITEM: FUSE, F7

LEAD ANALYST: ROBINSON

ASSESSMENT:

	CRITICALITY FLIGHT HDW/FUNC	REDUNDANCY SCREENS			CIL ITEM
		A	B	C	
NASA	[3 /1R]	[P]	[P]	[P]	[] *
IOA	[3 /3]	[]	[]	[]	[]
COMPARE	[/N]	[N]	[N]	[N]	[]

RECOMMENDATIONS: (If different from NASA)

[/] [] [] [] []
 (ADD/DELETE)

* CIL RETENTION RATIONALE: (If applicable)

ADEQUATE []
 INADEQUATE []

REMARKS:

UPGRADE IOA CRIT TO 3/1R AND CORRECT IOA SCREENS. SUBSEQUENT MULTIPLE FAILURES COULD CAUSE MOTOR BURNOUT AND COULD LEAD TO INABILITY TO SAFELY LATCH THE RMS AND SUBSEQUENT FAILURE OF THE GUILLOTINE/JETTISON SYSTEM
 COULD RESULT IN LOSS OF CREW/VEHICLE. THIS ONE NASA FMEA CORRESPONDS TO THE FOLLOWING IOA FMEAs: 4211, 4212, 4245, 4246, 4267, 4268, 4289, 4290, 4311, 4312, 4333, AND 4334. IOA RECOMMENDS COMBINING ALL LISTED IOA FMEAs INTO ONE TO ALLOW COMPARISON WITH THE NASA POST 51L FMEA.

APPENDIX C
ASSESSMENT WORKSHEET

ASSESSMENT DATE: 1/30/88
 ASSESSMENT ID: RMS-4290
 NASA FMEA #: 05-6IC-MRL-7A

NASA DATA:
 BASELINE []
 NEW [X]

SUBSYSTEM: RMS/EPD&C
 MDAC ID: 4290
 ITEM: FUSE, F3

LEAD ANALYST: ROBINSON

ASSESSMENT:

	CRITICALITY FLIGHT HDW/FUNC	REDUNDANCY SCREENS			CIL ITEM
		A	B	C	
NASA	[3 /1R]	[P]	[P]	[P]	[] *
IOA	[3 /3]	[]	[]	[]	[]
COMPARE	[/N]	[N]	[N]	[N]	[]

RECOMMENDATIONS: (If different from NASA)

[/] [] [] [] []
 (ADD/DELETE)

* CIL RETENTION RATIONALE: (If applicable)

ADEQUATE []
 INADEQUATE []

REMARKS:

UPGRADE IOA CRIT TO 3/1R AND CORRECT IOA SCREENS. SUBSEQUENT MULTIPLE FAILURES COULD CAUSE MOTOR BURNOUT AND COULD LEAD TO INABILITY TO SAFELY LATCH THE RMS AND SUBSEQUENT FAILURE OF THE GUILLOTINE/JETTISON SYSTEM COULD RESULT IN LOSS OF CREW/VEHICLE. THIS ONE NASA FMEA CORRESPONDS TO THE FOLLOWING IOA FMEAs: 4211, 4212, 4245, 4246, 4267, 4268, 4289, 4290, 4311, 4312, 4333, AND 4334. IOA RECOMMENDS COMBINING ALL LISTED IOA FMEAs INTO ONE TO ALLOW COMPARISON WITH THE NASA POST 51L FMEA.

APPENDIX C
ASSESSMENT WORKSHEET

ASSESSMENT DATE: 1/25/88
 ASSESSMENT ID: RMS-4291
 NASA FMEA #: 05-6IC-MRL-12

NASA DATA:
 BASELINE []
 NEW [X]

SUBSYSTEM: RMS/EPD&C
 MDAC ID: 4291
 ITEM: RESISTOR, R68

LEAD ANALYST: ROBINSON

ASSESSMENT:

	CRITICALITY FLIGHT HDW/FUNC	REDUNDANCY SCREENS			CIL ITEM
		A	B	C	
NASA	[3 / 3]	[N]	[N]	[N]	[] *
IOA	[3 / 3]	[]	[]	[]	[]
COMPARE	[/]	[N]	[N]	[N]	[]

RECOMMENDATIONS: (If different from NASA)

[/] [] [] [] []
 (ADD/DELETE)

* CIL RETENTION RATIONALE: (If applicable)

ADEQUATE []
 INADEQUATE []

REMARKS:

NO ISSUE. THE NASA FMEA ITEM IS THE "READY TO LATCH INDICATION CIRCUIT" WITH THE FAILURE MODE AS "ERRONEOUS INDICATION". THE IOA FMEAs ADDRESS THE INDIVIDUAL COMPONENTS. FOR COMPARISON PURPOSES, IOA RECOMMENDS COMBINING THE FOLLOWING IOA FMEAs: 4213 THRU 4216, 4247 THRU 4750, 4269 THRU 4272, 4291 THRU 4294, 4313 THRU 4316, AND 4335 THRU 4338.

APPENDIX C
ASSESSMENT WORKSHEET

ASSESSMENT DATE: 1/25/88
 ASSESSMENT ID: RMS-4292
 NASA FMEA #: 05-6IC-MRL-12

NASA DATA:
 BASELINE []
 NEW [X]

SUBSYSTEM: RMS/EPD&C
 MDAC ID: 4292
 ITEM: RESISTOR, R34

LEAD ANALYST: ROBINSON

ASSESSMENT:

	CRITICALITY FLIGHT HDW/FUNC	REDUNDANCY SCREENS			CIL ITEM
		A	B	C	
NASA	[3 / 3]	[N]	[N]	[N]	[] *
IOA	[3 / 3]	[]	[]	[]	[]
COMPARE	[/]	[N]	[N]	[N]	[]

RECOMMENDATIONS: (If different from NASA)

[/] [] [] [] []
 (ADD/DELETE)

* CIL RETENTION RATIONALE: (If applicable)

ADEQUATE []
 INADEQUATE []

REMARKS:

NO ISSUE. THE NASA FMEA ITEM IS THE "READY TO LATCH INDICATION CIRCUIT" WITH THE FAILURE MODE AS "ERRONEOUS INDICATION". THE IOA FMEAs ADDRESS THE INDIVIDUAL COMPONENTS. FOR COMPARISON PURPOSES, IOA RECOMMENDS COMBINING THE FOLLOWING IOA FMEAs: 4213 THRU 4216, 4247 THRU 4750, 4269 THRU 4272, 4291 THRU 4294, 4313 THRU 4316, AND 4335 THRU 4338.

APPENDIX C
ASSESSMENT WORKSHEET

ASSESSMENT DATE: 1/25/88
 ASSESSMENT ID: RMS-4293
 NASA FMEA #: 05-6IC-MRL-12

NASA DATA:
 BASELINE []
 NEW [X]

SUBSYSTEM: RMS/EPD&C
 MDAC ID: 4293
 ITEM: RESISTOR, R64

LEAD ANALYST: ROBINSON

ASSESSMENT:

	CRITICALITY FLIGHT HDW/FUNC	REDUNDANCY SCREENS			CIL ITEM
		A	B	C	
NASA	[3 / 3]	[N]	[N]	[N]	[] *
IOA	[3 / 3]	[]	[]	[]	[]
COMPARE	[/]	[N]	[N]	[N]	[]

RECOMMENDATIONS: (If different from NASA)

[/] [] [] [] []
 (ADD/DELETE)

* CIL RETENTION RATIONALE: (If applicable)

ADEQUATE []
 INADEQUATE []

REMARKS:

NO ISSUE. THE NASA FMEA ITEM IS THE "READY TO LATCH INDICATION CIRCUIT" WITH THE FAILURE MODE AS "ERRONEOUS INDICATION". THE IOA FMEAs ADDRESS THE INDIVIDUAL COMPONENTS. FOR COMPARISON PURPOSES, IOA RECOMMENDS COMBINING THE FOLLOWING IOA FMEAs: 4213 THRU 4216, 4247 THRU 4750, 4269 THRU 4272, 4291 THRU 4294, 4313 THRU 4316, AND 4335 THRU 4338.

APPENDIX C
ASSESSMENT WORKSHEET

ASSESSMENT DATE: 1/25/88
 ASSESSMENT ID: RMS-4294
 NASA FMEA #: 05-6IC-MRL-12

NASA DATA:
 BASELINE []
 NEW [X]

SUBSYSTEM: RMS/EPD&C
 MDAC ID: 4294
 ITEM: RESISTOR, R33

LEAD ANALYST: ROBINSON

ASSESSMENT:

	CRITICALITY FLIGHT HDW/FUNC	REDUNDANCY SCREENS			CIL ITEM
		A	B	C	
NASA	[3 / 3]	[N]	[N]	[N]	[] *
IOA	[3 / 3]	[]	[]	[]	[]
COMPARE	[/]	[N]	[N]	[N]	[]

RECOMMENDATIONS: (If different from NASA)

[/] [] [] [] []
 (ADD/DELETE)

* CIL RETENTION RATIONALE: (If applicable)

ADEQUATE []
 INADEQUATE []

REMARKS:

NO ISSUE. THE NASA FMEA ITEM IS THE "READY TO LATCH INDICATION CIRCUIT" WITH THE FAILURE MODE AS "ERRONEOUS INDICATION". THE IOA FMEAs ADDRESS THE INDIVIDUAL COMPONENTS. FOR COMPARISON PURPOSES, IOA RECOMMENDS COMBINING THE FOLLOWING IOA FMEAs: 4213 THRU 4216, 4247 THRU 4750, 4269 THRU 4272, 4291 THRU 4294, 4313 THRU 4316, AND 4335 THRU 4338.

APPENDIX C
ASSESSMENT WORKSHEET

ASSESSMENT DATE: 1/30/88
 ASSESSMENT ID: RMS-4295
 NASA FMEA #: 05-6IC-MRL-7

NASA DATA:
 BASELINE []
 NEW [X]

SUBSYSTEM: RMS/EPD&C
 MDAC ID: 4295
 ITEM: RESISTOR, R12

LEAD ANALYST: ROBINSON

ASSESSMENT:

	CRITICALITY FLIGHT HDW/FUNC	REDUNDANCY SCREENS			CIL ITEM
		A	B	C	
NASA	[3 /1R]	[P]	[P]	[P]	[] *
IOA	[3 /2R]	[]	[NA]	[NA]	[]
COMPARE	[/N]	[N]	[N]	[N]	[]

RECOMMENDATIONS: (If different from NASA)

[/] [] [] [] []
 (ADD/DELETE)

* CIL RETENTION RATIONALE: (If applicable)

ADEQUATE []
 INADEQUATE []

REMARKS:

IOA CONCURS WITH NASA FMEA. UPGRADE IOA CRIT TO 3/1R AND CORRECT IOA SCREENS. SUBSEQUENT MULTIPLE FAILURES COULD CAUSE MOTOR BURNOUT AND COULD LEAD TO INABILITY TO SAFELY LATCH THE RMS AND SUBSEQUENT FAILURE OF THE GUILLOTINE/JETTISON SYSTEM WHICH COULD CAUSE LOSS OF CREW/VEHICLE. THIS ONE NASA FMEA CORRESPONDS TO THE FOLLOWING 12 IOA FMEAs: 4217, 4218, 4251, 4252, 4273, 4274, 4295, 4296, 4317, 4318, 4339 AND 4340. IOA RECOMMENDS COMBINING ALL LISTED IOA FMEAs INTO ONE TO ALLOW COMPARISON WITH NASA POST 51L FMEA.

APPENDIX C
ASSESSMENT WORKSHEET

ASSESSMENT DATE: 1/30/88
 ASSESSMENT ID: RMS-4296
 NASA FMEA #: 05-6IC-MRL-7

NASA DATA:
 BASELINE []
 NEW [X]

SUBSYSTEM: RMS/EPD&C
 MDAC ID: 4296
 ITEM: RESISTOR, R2

LEAD ANALYST: ROBINSON

ASSESSMENT:

	CRITICALITY FLIGHT HDW/FUNC	REDUNDANCY SCREENS			CIL ITEM
		A	B	C	
NASA	[3 /1R]	[P]	[P]	[P]	[] *
IOA	[3 /2R]	[]	[NA]	[NA]	[]
COMPARE	[/N]	[N]	[N]	[N]	[]

RECOMMENDATIONS: (If different from NASA)

[/] [] [] [] []
 (ADD/DELETE)

* CIL RETENTION RATIONALE: (If applicable)

ADEQUATE []
 INADEQUATE []

REMARKS:

IOA CONCURS WITH NASA FMEA. UPGRADE IOA CRIT TO 3/1R AND CORRECT IOA SCREENS. SUBSEQUENT MULTIPLE FAILURES COULD CAUSE MOTOR BURNOUT AND COULD LEAD TO INABILITY TO SAFELY LATCH THE RMS AND SUBSEQUENT FAILURE OF THE GUILLOTINE/JETTISON SYSTEM WHICH COULD CAUSE LOSS OF CREW/VEHICLE. THIS ONE NASA FMEA CORRESPONDS TO THE FOLLOWING 12 IOA FMEAs: 4217, 4218, 4251, 4252, 4273, 4274, 4295, 4296, 4317, 4318, 4339 AND 4340. IOA RECOMMENDS COMBINING ALL LISTED IOA FMEAs INTO ONE TO ALLOW COMPARISON WITH NASA POST 51L FMEA.

APPENDIX C
ASSESSMENT WORKSHEET

ASSESSMENT DATE: 1/25/88
 ASSESSMENT ID: RMS-4297
 NASA FMEA #: 05-6IC-MRL-11

NASA DATA:
 BASELINE []
 NEW [X]

SUBSYSTEM: RMS/EPD&C
 MDAC ID: 4297
 ITEM: RESISTOR, R35

LEAD ANALYST: ROBINSON

ASSESSMENT:

	CRITICALITY FLIGHT HDW/FUNC	REDUNDANCY SCREENS			CIL ITEM
		A	B	C	
NASA	[3 / 3]	[]	[]	[]	[] *
IOA	[3 / 3]	[]	[]	[]	[]
COMPARE	[/]	[]	[]	[]	[]

RECOMMENDATIONS: (If different from NASA)

[/] [] [] [] []
 (ADD/DELETE)

* CIL RETENTION RATIONALE: (If applicable)

ADEQUATE []
 INADEQUATE []

REMARKS:

NO ISSUE. THE NASA FMEA ITEM IS "INDICATION CIRCUIT - HYBRID DRIVER TYPE 1, RESISTORS & EVENT INDICATION", AND INCLUDES SYSTEM 1 FWD/MID/AFT PEDESTAL CIRCUIT COMPONENTS. FOR COMPARISON, IOA RECOMMENDS COMBINING THE FOLLOWING IOA FMEAs: 4219 THRU 4234, 4253 THRU 4256, 4275 THRU 4278, 4297 THRU 4300, 4319 THRU 4322 AND 4341 THRU 4344. FMEAs WITH 3/3 CRIT DO NOT REQUIRE ASSESSMENT.

APPENDIX C
ASSESSMENT WORKSHEET

ASSESSMENT DATE: 1/25/88
 ASSESSMENT ID: RMS-4298
 NASA FMEA #: 05-6IC-MRL-11

NASA DATA:
 BASELINE []
 NEW [X]

SUBSYSTEM: RMS/EPD&C
 MDAC ID: 4298
 ITEM: RESISTOR, R31

LEAD ANALYST: ROBINSON

ASSESSMENT:

	CRITICALITY FLIGHT HDW/FUNC	REDUNDANCY SCREENS			CIL ITEM
		A	B	C	
NASA	[3 / 3]	[]	[]	[]	[] *
IOA	[3 / 3]	[]	[]	[]	[]
COMPARE	[/]	[]	[]	[]	[]

RECOMMENDATIONS: (If different from NASA)

[/] [] [] [] []
 (ADD/DELETE)

* CIL RETENTION RATIONALE: (If applicable)

ADEQUATE []
 INADEQUATE []

REMARKS:

NO ISSUE. THE NASA FMEA ITEM IS "INDICATION CIRCUIT - HYBRID DRIVER TYPE 1, RESISTORS & EVENT INDICATION", AND INCLUDES SYSTEM 1 FWD/MID/AFT PEDESTAL CIRCUIT COMPONENTS. FOR COMPARISON, IOA RECOMMENDS COMBINING THE FOLLOWING IOA FMEAs: 4219 THRU 4234, 4253 THRU 4256, 4275 THRU 4278, 4297 THRU 4300, 4319 THRU 4322 AND 4341 THRU 4344. FMEAs WITH 3/3 CRIT DO NOT REQUIRE ASSESSMENT.

APPENDIX C
ASSESSMENT WORKSHEET

ASSESSMENT DATE: 1/25/88
 ASSESSMENT ID: RMS-4299
 NASA FMEA #: 05-6IC-MRL-11

NASA DATA:
 BASELINE []
 NEW [X]

SUBSYSTEM: RMS/EPD&C
 MDAC ID: 4299
 ITEM: RESISTOR, R34

LEAD ANALYST: ROBINSON

ASSESSMENT:

	CRITICALITY FLIGHT HDW/FUNC	REDUNDANCY SCREENS			CIL ITEM
		A	B	C	
NASA	[3 / 3]	[]	[]	[]	[] *
IOA	[3 / 3]	[]	[]	[]	[]
COMPARE	[/]	[]	[]	[]	[]

RECOMMENDATIONS: (If different from NASA)

[/] [] [] [] []
 (ADD/DELETE)

* CIL RETENTION RATIONALE: (If applicable)

ADEQUATE []
 INADEQUATE []

REMARKS:

NO ISSUE. THE NASA FMEA ITEM IS "INDICATION CIRCUIT - HYBRID DRIVER TYPE 1, RESISTORS & EVENT INDICATION", AND INCLUDES SYSTEM 1 FWD/MID/AFT PEDESTAL CIRCUIT COMPONENTS. FOR COMPARISON, IOA RECOMMENDS COMBINING THE FOLLOWING IOA FMEAs: 4219 THRU 4234, 4253 THRU 4256, 4275 THRU 4278, 4297 THRU 4300, 4319 THRU 4322 AND 4341 THRU 4344. FMEAs WITH 3/3 CRIT DO NOT REQUIRE ASSESSMENT.

APPENDIX C
ASSESSMENT WORKSHEET

ASSESSMENT DATE: 1/25/88
 ASSESSMENT ID: RMS-4300
 NASA FMEA #: 05-6IC-MRL-11

NASA DATA:
 BASELINE []
 NEW [X]

SUBSYSTEM: RMS/EPD&C
 MDAC ID: 4300
 ITEM: RESISTOR, R30

LEAD ANALYST: ROBINSON

ASSESSMENT:

	CRITICALITY FLIGHT HDW/FUNC	REDUNDANCY SCREENS			CIL ITEM
		A	B	C	
NASA	[3 / 3]	[]	[]	[]	[] *
IOA	[3 / 3]	[]	[]	[]	[]
COMPARE	[/]	[]	[]	[]	[]

RECOMMENDATIONS: (If different from NASA)

[/] [] [] [] []
 (ADD/DELETE)

* CIL RETENTION RATIONALE: (If applicable)

ADEQUATE []
 INADEQUATE []

REMARKS:

NO ISSUE. THE NASA FMEA ITEM IS "INDICATION CIRCUIT - HYBRID DRIVER TYPE 1, RESISTORS & EVENT INDICATION", AND INCLUDES SYSTEM 1 FWD/MID/AFT PEDESTAL CIRCUIT COMPONENTS. FOR COMPARISON, IOA RECOMMENDS COMBINING THE FOLLOWING IOA FMEAs: 4219 THRU 4234, 4253 THRU 4256, 4275 THRU 4278, 4297 THRU 4300, 4319 THRU 4322 AND 4341 THRU 4344. FMEAs WITH 3/3 CRIT DO NOT REQUIRE ASSESSMENT.

APPENDIX C
ASSESSMENT WORKSHEET

ASSESSMENT DATE: 1/24/88
 ASSESSMENT ID: RMS-4301
 NASA FMEA #: 05-6IC-MRL-4

NASA DATA:
 BASELINE []
 NEW [X]

SUBSYSTEM: RMS/EPD&C
 MDAC ID: 4301
 ITEM: HYBRID RELAY, K59

LEAD ANALYST: ROBINSON

ASSESSMENT:

	CRITICALITY FLIGHT HDW/FUNC	REDUNDANCY SCREENS			CIL ITEM
		A	B	C	
NASA	[3 /1R]	[P]	[P]	[P]	[] *
IOA	[3 /2R]	[]	[NA]	[NA]	[]
COMPARE	[/N]	[N]	[N]	[N]	[]

RECOMMENDATIONS: (If different from NASA)

[/] [] [] [] []
 (ADD/DELETE)

* CIL RETENTION RATIONALE: (If applicable)

ADEQUATE []
 INADEQUATE []

REMARKS:

NO ISSUE.
 IOA CONCURS WITH THE POST 51L CRIT OF 3/1R. IOA SCREENS SHOULD BE 1-P-P. TO COMPARE WITH THE NASA FMEA, IOA RECOMMENDS COMBINING THE FOLLOWING 24 IOA FMEAs: 4201, 4203, 4205, 4207, 4235, 4237, 4239, 4241, 4257, 4259, 4261, 4263, 4279, 4281, 4283, 4285, 4301, 4303, 4305, 4307, 4323, 4325, 4327, AND 4329. THE IOA FMEAs ARE FOR 12 PORT AND 12 STARBOARD HYBRID RELAYS USED BY SYSTEM 1 AND SYSTEM 2, FWD, MID, AND AFT LATCH/RELEASE FOR BOTH PORT AND STARBOARD ARMS.

APPENDIX C
ASSESSMENT WORKSHEET

ASSESSMENT DATE: 1/30/88
 ASSESSMENT ID: RMS-4302
 NASA FMEA #: 05-6IC-MRL-5

NASA DATA:
 BASELINE []
 NEW [X]

SUBSYSTEM: RMS/EPD&C
 MDAC ID: 4302
 ITEM: HYBRID RELAY, K59

LEAD ANALYST: ROBINSON

ASSESSMENT:

	CRITICALITY FLIGHT HDW/FUNC	REDUNDANCY SCREENS			CIL ITEM
		A	B	C	
NASA	[3 /1R]	[P]	[P]	[P]	[] *
IOA	[3 /2R]	[]	[NA]	[NA]	[]
COMPARE	[/N]	[N]	[N]	[N]	[]

RECOMMENDATIONS: (If different from NASA)

[/] [] [] [] []
 (ADD/DELETE)

* CIL RETENTION RATIONALE: (If applicable)

ADEQUATE []
 INADEQUATE []

REMARKS:

NO ISSUE.

IOA CONCURS WITH THE POST 51L CRIT OF 3/1R. IOA SCREENS SHOULD BE 1 - P - P. IOA RECOMMENDS COMBINING THE FOLLOWING IOA FMEAs TO COMPARE WITH THE NASA FMEA. COMBINE THE FOLLOWING 12 IOA FMEAs: 4202, 4204, 4236, 4238, 4258, 4260, 4280, 4282, 4302, 4304, THE 12 IOA FMEAs ARE FOR 6 INDIVIDUAL PORT AND 6 INDIVIDUAL STARBOARD. HYBRID RELAYS FOR LATCHING.

APPENDIX C
ASSESSMENT WORKSHEET

ASSESSMENT DATE: 1/24/88
 ASSESSMENT ID: RMS-4303
 NASA FMEA #: 05-6IC-MRL-4

NASA DATA:
 BASELINE []
 NEW [X]

SUBSYSTEM: RMS/EPD&C
 MDAC ID: 4303
 ITEM: HYBRID RELAY, K76

LEAD ANALYST: ROBINSON

ASSESSMENT:

	CRITICALITY FLIGHT HDW/FUNC	REDUNDANCY SCREENS			CIL ITEM
		A	B	C	
NASA	[3 /1R]	[P]	[P]	[P]	[] *
IOA	[3 /2R]	[]	[NA]	[NA]	[]
COMPARE	[/N]	[N]	[N]	[N]	[]

RECOMMENDATIONS: (If different from NASA)

[/] [] [] [] []
 (ADD/DELETE)

* CIL RETENTION RATIONALE: (If applicable)

ADEQUATE []
 INADEQUATE []

REMARKS:

NO ISSUE.
 IOA CONCURS WITH THE POST 51L CRIT OF 3/1R. IOA SCREENS SHOULD BE 1-P-P. TO COMPARE WITH THE NASA FMEA, IOA RECOMMENDS COMBINING THE FOLLOWING 24 IOA FMEAs: 4201, 4203, 4205, 4207, 4235, 4237, 4239, 4241, 4257, 4259, 4261, 4263, 4279, 4281, 4283, 4285, 4301, 4303, 4305, 4307, 4323, 4325, 4327, AND 4329. THE IOA FMEAs ARE FOR 12 PORT AND 12 STARBOARD HYBRID RELAYS USED BY SYSTEM 1 AND SYSTEM 2, FWD, MID, AND AFT LATCH/RELEASE FOR BOTH PORT AND STARBOARD ARMS.

APPENDIX C
ASSESSMENT WORKSHEET

ASSESSMENT DATE: 1/30/88
 ASSESSMENT ID: RMS-4304
 NASA FMEA #: 05-6IC-MRL-5

NASA DATA:
 BASELINE []
 NEW [X]

SUBSYSTEM: RMS/EPD&C
 MDAC ID: 4304
 ITEM: HYBRID RELAY, K76

LEAD ANALYST: ROBINSON

ASSESSMENT:

	CRITICALITY FLIGHT HDW/FUNC	REDUNDANCY SCREENS			CIL ITEM
		A	B	C	
NASA	[3 /1R]	[P]	[P]	[P]	[] *
IOA	[3 /2R]	[]	[NA]	[NA]	[]
COMPARE	[/N]	[N]	[N]	[N]	[]

RECOMMENDATIONS: (If different from NASA)

[/] [] [] [] []
 (ADD/DELETE)

* CIL RETENTION RATIONALE: (If applicable)

ADEQUATE []
 INADEQUATE []

REMARKS:

NO ISSUE.
 IOA CONCURS WITH THE POST 51L CRIT OF 3/1R. IOA SCREENS SHOULD BE 1 - P - P. IOA RECOMMENDS COMBINING THE FOLLOWING IOA FMEAs TO COMPARE WITH THE NASA FMEA. COMBINE THE FOLLOWING 12 IOA FMEAs: 4202, 4204, 4236, 4238, 4258, 4260, 4280, 4282, 4302, 4304, THE 12 IOA FMEAs ARE FOR 6 INDIVIDUAL PORT AND 6 INDIVIDUAL STARBOARD HYBRID RELAYS FOR LATCHING.

APPENDIX C
ASSESSMENT WORKSHEET

ASSESSMENT DATE: 1/24/88
 ASSESSMENT ID: RMS-4305
 NASA FMEA #: 05-6IC-MRL-4

NASA DATA:
 BASELINE []
 NEW [X]

SUBSYSTEM: RMS/EPD&C
 MDAC ID: 4305
 ITEM: HYBRID RELAY, K71

LEAD ANALYST: ROBINSON

ASSESSMENT:

	CRITICALITY FLIGHT HDW/FUNC	REDUNDANCY SCREENS			CIL ITEM
		A	B	C	
NASA	[3 /1R]	[P]	[P]	[P]	[] *
IOA	[3 /2R]	[]	[NA]	[NA]	[]
COMPARE	[/N]	[N]	[N]	[N]	[]

RECOMMENDATIONS: (If different from NASA)

[/] [] [] [] []
 (ADD/DELETE)

* CIL RETENTION RATIONALE: (If applicable)

ADEQUATE []
 INADEQUATE []

REMARKS:

NO ISSUE.
 IOA CONCURS WITH THE POST 51L CRIT OF 3/1R. IOA SCREENS SHOULD BE 1-P-P. TO COMPARE WITH THE NASA FMEA, IOA RECOMMENDS COMBINING THE FOLLOWING 24 IOA FMEAs: 4201, 4203, 4205, 4207, 4235, 4237, 4239, 4241, 4257, 4259, 4261, 4263, 4279, 4281, 4283, 4285, 4301, 4303, 4305, 4307, 4323, 4325, 4327, AND 4329. THE IOA FMEAs ARE FOR 12 PORT AND 12 STARBOARD HYBRID RELAYS USED BY SYSTEM 1 AND SYSTEM 2, FWD, MID, AND AFT LATCH/RELEASE FOR BOTH PORT AND STARBOARD ARMS.

APPENDIX C
ASSESSMENT WORKSHEET

ASSESSMENT DATE: 2/16/88
 ASSESSMENT ID: RMS-4306
 NASA FMEA #: 05-6IC-MRL-6

NASA DATA:
 BASELINE []
 NEW [X]

SUBSYSTEM: RMS/EPD&C
 MDAC ID: 4306
 ITEM: HYBRID RELAY, K71

LEAD ANALYST: ROBINSON

ASSESSMENT:

	CRITICALITY FLIGHT HDW/FUNC	REDUNDANCY SCREENS			CIL ITEM
		A	B	C	
NASA	[2 /1R]	[P]	[F]	[P]	[X] *
IOA	[3 /2R]	[]	[NA]	[NA]	[]
COMPARE	[N /N]	[N]	[N]	[N]	[N]

RECOMMENDATIONS: (If different from NASA)

[/] [] [] [] []
 (ADD/DELETE)

* CIL RETENTION RATIONALE: (If applicable)

ADEQUATE []
 INADEQUATE []

REMARKS:

NO ISSUE.

IOA CONCURS WITH THE POST 51L CRIT OF 3/1R. IOA SCREENS SHOULD BE 1 - P - P. IOA RECOMMENDS COMBINING THE FOLLOWING IOA FMEAS TO COMPARE WITH THE NASA FMEA. COMBINE THE FOLLOWING 6 IOA FMEAS: 4206, 4208, 4240, 4242, 4262, 4264, 4284, 4286, 4306, THE 12 IOA FMEAS ARE FOR 6 INDIVIDUAL PORT AND 6 INDIVIDUAL STARBOARD HYBRID RELAYS FOR RELEASING.

APPENDIX C
ASSESSMENT WORKSHEET

ASSESSMENT DATE: 1/24/88
 ASSESSMENT ID: RMS-4307
 NASA FMEA #: 05-6IC-MRL-4

NASA DATA:
 BASELINE []
 NEW [X]

SUBSYSTEM: RMS/EPD&C
 MDAC ID: 4307
 ITEM: HYBRID RELAY, K74

LEAD ANALYST: ROBINSON

ASSESSMENT:

	CRITICALITY FLIGHT HDW/FUNC	REDUNDANCY SCREENS			CIL ITEM
		A	B	C	
NASA	[3 /1R]	[P]	[P]	[P]	[] *
IOA	[3 /2R]	[]	[NA]	[NA]	[]
COMPARE	[/N]	[N]	[N]	[N]	[]

RECOMMENDATIONS: (If different from NASA)

[/] [] [] [] []
 (ADD/DELETE)

* CIL RETENTION RATIONALE: (If applicable)

ADEQUATE []
 INADEQUATE []

REMARKS:
 NO ISSUE.

IOA CONCURS WITH THE POST 51L CRIT OF 3/1R. IOA SCREENS SHOULD BE 1-P-P. TO COMPARE WITH THE NASA FMEA, IOA RECOMMENDS COMBINING THE FOLLOWING 24 IOA FMEAs: 4201, 4203, 4205, 4207, 4235, 4237, 4239, 4241, 4257, 4259, 4261, 4263, 4279, 4281, 4283, 4285, 4301, 4303, 4305, 4307, 4323, 4325, 4327, AND 4329. THE IOA FMEAs ARE FOR 12 PORT AND 12 STARBOARD HYBRID RELAYS USED BY SYSTEM 1 AND SYSTEM 2, FWD, MID, AND AFT LATCH/RELEASE FOR BOTH PORT AND STARBOARD ARMS.

APPENDIX C
ASSESSMENT WORKSHEET

ASSESSMENT DATE: 2/16/88
 ASSESSMENT ID: RMS-4308
 NASA FMEA #: 05-6IC-MRL-6

NASA DATA:
 BASELINE []
 NEW [X]

SUBSYSTEM: RMS/EPD&C
 MDAC ID: 4308
 ITEM: HYBRID RELAY, K74

LEAD ANALYST: ROBINSON

ASSESSMENT:

	CRITICALITY FLIGHT HDW/FUNC	REDUNDANCY SCREENS			CIL ITEM
		A	B	C	
NASA	[2 /1R]	[P]	[F]	[P]	[X] *
IOA	[3 /2R]	[]	[NA]	[NA]	[]
COMPARE	[N /N]	[N]	[N]	[N]	[N]

RECOMMENDATIONS: (If different from NASA)

[/] [] [] [] []
 (ADD/DELETE)

* CIL RETENTION RATIONALE: (If applicable)

ADEQUATE []
 INADEQUATE []

REMARKS:

NO ISSUE.

IOA CONCURS WITH THE POST 51L CRIT OF 3/1R. IOA SCREENS SHOULD BE 1 - P - P. IOA RECOMMENDS COMBINING THE FOLLOWING IOA FMEAS TO COMPARE WITH THE NASA FMEA. COMBINE THE FOLLOWING 6 IOA FMEAs: 4206, 4208, 4240, 4242, 4262, 4264, 4284, 4286, 4306, THE 12 IOA FMEAs ARE FOR 6 INDIVIDUAL PORT AND 6 INDIVIDUAL STARBOARD HYBRID RELAYS FOR RELEASING.

APPENDIX C
ASSESSMENT WORKSHEET

ASSESSMENT DATE: 2/14/88
 ASSESSMENT ID: RMS-4309
 NASA FMEA #: 05-6ID-2127-1

NASA DATA:
 BASELINE []
 NEW [X]

SUBSYSTEM: RMS/EPD&C
 MDAC ID: 4309
 ITEM: RELAY, K78

LEAD ANALYST: ROBINSON

ASSESSMENT:

	CRITICALITY FLIGHT HDW/FUNC	REDUNDANCY SCREENS			CIL ITEM
		A	B	C	
NASA	[2 /1R]	[P]	[P]	[P]	[X] *
IOA	[3 /2R]	[]	[NA]	[NA]	[]
COMPARE	[N /N]	[N]	[N]	[N]	[N]

RECOMMENDATIONS: (If different from NASA)

[/] [] [] [P] []
 (ADD/DELETE)

* CIL RETENTION RATIONALE: (If applicable)

ADEQUATE []
 INADEQUATE []

REMARKS:

NO ISSUE. RECOMMEND UPGRADING IOA FMEA TO CRITICALITY 2/1R.
 THE IOA FMEA FOR FAILURE OF THESE RELAYS WAS GENERATED AS PART OF
 THE MANIPULATOR RETENTION LATCH CONTROL CIRCUIT WHICH IS 05-6I
 SET OF NASA FMEAS ALSO AND THEREFORE THE RESULT OF THE FAILURES
 DO NOT MATCH WHEN COMPARED. THE RELAYS ARE 4 POLE, 2
 POSITION LATCHING RELAYS AND APPEAR IN BOTH THE LATCH CONTROL AND
 THE JETTISON/GUILLOTINE CIRCUITS. IOA CONCURS WITH THE NASA
 FAILURE.

APPENDIX C
ASSESSMENT WORKSHEET

ASSESSMENT DATE: 2/14/88
 ASSESSMENT ID: RMS-4310
 NASA FMEA #: 05-6ID-2130-1

NASA DATA:
 BASELINE [X]
 NEW []

SUBSYSTEM: RMS/EPD&C
 MDAC ID: 4310
 ITEM: RELAY, K78

LEAD ANALYST: ROBINSON

ASSESSMENT:

	CRITICALITY FLIGHT HDW/FUNC	REDUNDANCY SCREENS			CIL ITEM
		A	B	C	
NASA	[3 / 3]	[P]	[P]	[P]	[] *
IOA	[3 / 2R]	[P]	[NA]	[NA]	[]
COMPARE	[/N]	[]	[N]	[N]	[]

RECOMMENDATIONS: (If different from NASA)

[3 / 2R] [] [] [P] []
 (ADD/DELETE)

* CIL RETENTION RATIONALE: (If applicable)

ADEQUATE []
 INADEQUATE []

REMARKS:

RECOMMEND UPGRADING THE NASA FMEA TO 3/2R. RECOMMEND COMBINING COMPONENTS IN IOA FMEAs 4244 AND 4310. THE IOA FMEA FOR FAILURE OF THESE RELAYS WAS GENERATED AS PART OF THE MANIPULATOR RETENTION LATCH CONTROL CIRCUIT WHICH IS 05-6I SET OF NASA FMEAS ALSO AND THEREFORE THE RESULT OF THE FAILURES DO NOT MATCH WHEN COMPARED. THE RELAYS ARE 4 POLE, 2 POSITION LATCHING RELAYS AND APPEAR IN BOTH THE LATCH CONTROL AND THE JETTISON/GUILLOTINE CIRCUITS. IOA CONCURS WITH THE NASA FAILURE.

APPENDIX C
ASSESSMENT WORKSHEET

ASSESSMENT DATE: 1/30/88
 ASSESSMENT ID: RMS-4311
 NASA FMEA #: 05-6IC-MRL-7A

NASA DATA:
 BASELINE []
 NEW [X]

SUBSYSTEM: RMS/EPD&C
 MDAC ID: 4311
 ITEM: FUSE, F5,

LEAD ANALYST: ROBINSON

ASSESSMENT:

	CRITICALITY FLIGHT HDW/FUNC	REDUNDANCY SCREENS			CIL ITEM
		A	B	C	
NASA	[3 /1R]	[P]	[P]	[P]	[] *
IOA	[3 /3]	[]	[]	[]	[]
COMPARE	[/N]	[N]	[N]	[N]	[]

RECOMMENDATIONS: (If different from NASA)

[/] [] [] [] [] (ADD/DELETE)

* CIL RETENTION RATIONALE: (If applicable)

ADEQUATE []
 INADEQUATE []

REMARKS:

UPGRADE IOA CRIT TO 3/1R AND CORRECT IOA SCREENS. SUBSEQUENT MULTIPLE FAILURES COULD CAUSE MOTOR BURNOUT AND COULD LEAD TO INABILITY TO SAFELY LATCH THE RMS AND SUBSEQUENT FAILURE OF THE GUILLOTINE/JETTISON SYSTEM
 COULD RESULT IN LOSS OF CREW/VEHICLE. THIS ONE NASA FMEA CORRESPONDS TO THE FOLLOWING IOA FMEAs: 4211, 4212, 4245, 4246, 4267, 4268, 4289, 4290, 4311, 4312, 4333, AND 4334. IOA RECOMMENDS COMBINING ALL LISTED IOA FMEAs INTO ONE TO ALLOW COMPARISON WITH THE NASA POST 51L FMEA.

APPENDIX C
ASSESSMENT WORKSHEET

ASSESSMENT DATE: 1/30/88
 ASSESSMENT ID: RMS-4312
 NASA FMEA #: 05-6IC-MRL-7A

NASA DATA:
 BASELINE []
 NEW [X]

SUBSYSTEM: RMS/EPD&C
 MDAC ID: 4312
 ITEM: FUSE, F9

LEAD ANALYST: ROBINSON

ASSESSMENT:

	CRITICALITY FLIGHT HDW/FUNC	REDUNDANCY SCREENS			CIL ITEM
		A	B	C	
NASA	[3 /1R]	[P]	[P]	[P]	[] *
IOA	[3 /3]	[]	[]	[]	[]
COMPARE	[/N]	[N]	[N]	[N]	[]

RECOMMENDATIONS: (If different from NASA)

[/] [] [] [] []
 (ADD/DELETE)

* CIL RETENTION RATIONALE: (If applicable)

ADEQUATE []
 INADEQUATE []

REMARKS:

UPGRADE IOA CRIT TO 3/1R AND CORRECT IOA SCREENS. SUBSEQUENT MULTIPLE FAILURES COULD CAUSE MOTOR BURNOUT AND COULD LEAD TO INABILITY TO SAFELY LATCH THE RMS AND SUBSEQUENT FAILURE OF THE GUILLOTINE/JETTISON SYSTEM COULD RESULT IN LOSS OF CREW/VEHICLE. THIS ONE NASA FMEA CORRESPONDS TO THE FOLLOWING IOA FMEAs: 4211, 4212, 4245, 4246, 4267, 4268, 4289, 4290, 4311, 4312, 4333, AND 4334. IOA RECOMMENDS COMBINING ALL LISTED IOA FMEAs INTO ONE TO ALLOW COMPARISON WITH THE NASA POST 51L FMEA.

APPENDIX C
ASSESSMENT WORKSHEET

ASSESSMENT DATE: 1/25/88
 ASSESSMENT ID: RMS-4313
 NASA FMEA #: 05-6IC-MRL-12

NASA DATA:
 BASELINE []
 NEW [X]

SUBSYSTEM: RMS/EPD&C
 MDAC ID: 4313
 ITEM: RESISTOR, R66

LEAD ANALYST: ROBINSON

ASSESSMENT:

	CRITICALITY FLIGHT HDW/FUNC	REDUNDANCY SCREENS			CIL ITEM
		A	B	C	
NASA	[3 / 3]	[N]	[N]	[N]	[] *
IOA	[3 / 3]	[]	[]	[]	[]
COMPARE	[/]	[N]	[N]	[N]	[]

RECOMMENDATIONS: (If different from NASA)

[/] [] [] [] []
 (ADD/DELETE)

* CIL RETENTION RATIONALE: (If applicable)

ADEQUATE []
 INADEQUATE []

REMARKS:

NO ISSUE. THE NASA FMEA ITEM IS THE "READY TO LATCH INDICATION CIRCUIT" WITH THE FAILURE MODE AS "ERRONEOUS INDICATION". THE IOA FMEAs ADDRESS THE INDIVIDUAL COMPONENTS. FOR COMPARISON PURPOSES, IOA RECOMMENDS COMBINING THE FOLLOWING IOA FMEAs: 4213 THRU 4216, 4247 THRU 4750, 4269 THRU 4272, 4291 THRU 4294, 4313 THRU 4316, AND 4335 THRU 4338.

APPENDIX C
ASSESSMENT WORKSHEET

ASSESSMENT DATE: 1/25/88
 ASSESSMENT ID: RMS-4314
 NASA FMEA #: 05-6IC-MRL-12

NASA DATA:
 BASELINE []
 NEW [X]

SUBSYSTEM: RMS/EPD&C
 MDAC ID: 4314
 ITEM: RESISTOR, R66

LEAD ANALYST: ROBINSON

ASSESSMENT:

	CRITICALITY FLIGHT HDW/FUNC	REDUNDANCY SCREENS			CIL ITEM
		A	B	C	
NASA	[3 / 3]	[N]	[N]	[N]	[] *
IOA	[3 / 3]	[]	[]	[]	[]
COMPARE	[/]	[N]	[N]	[N]	[]

RECOMMENDATIONS: (If different from NASA)

[/] [] [] [] []
 (ADD/DELETE)

* CIL RETENTION RATIONALE: (If applicable)

ADEQUATE []
 INADEQUATE []

REMARKS:
 NO ISSUE. THE NASA FMEA ITEM IS THE "READY TO LATCH INDICATION CIRCUIT" WITH THE FAILURE MODE AS "ERRONEOUS INDICATION". THE IOA FMEAs ADDRESS THE INDIVIDUAL COMPONENTS. FOR COMPARISON PURPOSES, IOA RECOMMENDS COMBINING THE FOLLOWING IOA FMEAs: 4213 THRU 4216, 4247 THRU 4750, 4269 THRU 4272, 4291 THRU 4294, 4313 THRU 4316, AND 4335 THRU 4338.

APPENDIX C
ASSESSMENT WORKSHEET

ASSESSMENT DATE: 1/25/88
 ASSESSMENT ID: RMS-4315
 NASA FMEA #: 05-6IC-MRL-12

NASA DATA:
 BASELINE []
 NEW [X]

SUBSYSTEM: RMS/EPD&C
 MDAC ID: 4315
 ITEM: RESISTOR, R62

LEAD ANALYST: ROBINSON

ASSESSMENT:

	CRITICALITY FLIGHT HDW/FUNC	REDUNDANCY SCREENS			CIL ITEM
		A	B	C	
NASA	[3 / 3]	[N]	[N]	[N]	[] *
IOA	[3 / 3]	[]	[]	[]	[]
COMPARE	[/]	[N]	[N]	[N]	[]

RECOMMENDATIONS: (If different from NASA)

[/] [] [] [] []
 (ADD/DELETE)

* CIL RETENTION RATIONALE: (If applicable)

ADEQUATE []
 INADEQUATE []

REMARKS:

NO ISSUE. THE NASA FMEA ITEM IS THE "READY TO LATCH INDICATION CIRCUIT" WITH THE FAILURE MODE AS "ERRONEOUS INDICATION". THE IOA FMEAs ADDRESS THE INDIVIDUAL COMPONENTS. FOR COMPARISON PURPOSES, IOA RECOMMENDS COMBINING THE FOLLOWING IOA FMEAs: 4213 THRU 4216, 4247 THRU 4750, 4269 THRU 4272, 4291 THRU 4294, 4313 THRU 4316, AND 4335 THRU 4338.

APPENDIX C
ASSESSMENT WORKSHEET

ASSESSMENT DATE: 1/25/88
 ASSESSMENT ID: RMS-4316
 NASA FMEA #: 05-6IC-MRL-12

NASA DATA:
 BASELINE []
 NEW [X]

SUBSYSTEM: RMS/EPD&C
 MDAC ID: 4316
 ITEM: RESISTOR, R67

LEAD ANALYST: ROBINSON

ASSESSMENT:

	CRITICALITY FLIGHT HDW/FUNC	REDUNDANCY SCREENS			CIL ITEM
		A	B	C	
NASA	[3 / 3]	[N]	[N]	[N]	[] *
IOA	[3 / 3]	[]	[]	[]	[]
COMPARE	[/]	[N]	[N]	[N]	[]

RECOMMENDATIONS: (If different from NASA)

[/] [] [] [] []
 (ADD/DELETE)

* CIL RETENTION RATIONALE: (If applicable)

ADEQUATE []
 INADEQUATE []

REMARKS:

NO ISSUE. THE NASA FMEA ITEM IS THE "READY TO LATCH INDICATION CIRCUIT" WITH THE FAILURE MODE AS "ERRONEOUS INDICATION". THE IOA FMEAs ADDRESS THE INDIVIDUAL COMPONENTS. FOR COMPARISON PURPOSES, IOA RECOMMENDS COMBINING THE FOLLOWING IOA FMEAs: 4213 THRU 4216, 4247 THRU 4750, 4269 THRU 4272, 4291 THRU 4294, 4313 THRU 4316, AND 4335 THRU 4338.

APPENDIX C
ASSESSMENT WORKSHEET

ASSESSMENT DATE: 1/30/88
 ASSESSMENT ID: RMS-4317
 NASA FMEA #: 05-6IC-MRL-7

NASA DATA:
 BASELINE []
 NEW [X]

SUBSYSTEM: RMS/EPD&C
 MDAC ID: 4317
 ITEM: RESISTOR, R10

LEAD ANALYST: ROBINSON

ASSESSMENT:

	CRITICALITY FLIGHT HDW/FUNC	REDUNDANCY SCREENS			CIL ITEM
		A	B	C	
NASA	[3 /1R]	[P]	[P]	[P]	[] *
IOA	[3 /2R]	[]	[NA]	[NA]	[]
COMPARE	[/N]	[N]	[N]	[N]	[]

RECOMMENDATIONS: (If different from NASA)

[/] [] [] [] []
 (ADD/DELETE)

* CIL RETENTION RATIONALE: (If applicable)

ADEQUATE []
 INADEQUATE []

REMARKS:

IOA CONCURS WITH NASA FMEA. UPGRADE IOA CRIT TO 3/1R AND CORRECT IOA SCREENS. SUBSEQUENT MULTIPLE FAILURES COULD CAUSE MOTOR BURNOUT AND COULD LEAD TO INABILITY TO SAFELY LATCH THE RMS AND SUBSEQUENT FAILURE OF THE GUILLOTINE/JETTISON SYSTEM WHICH COULD CAUSE LOSS OF CREW/VEHICLE. THIS ONE NASA FMEA CORRESPONDS TO THE FOLLOWING 12 IOA FMEAs: 4217, 4218, 4251, 4252, 4273, 4274, 4295, 4296, 4317, 4318, 4339 AND 4340. IOA RECOMMENDS COMBINING ALL LISTED IOA FMEAs INTO ONE TO ALLOW COMPARISON WITH NASA POST 51L FMEA.

APPENDIX C
ASSESSMENT WORKSHEET

ASSESSMENT DATE: 1/30/88
 ASSESSMENT ID: RMS-4318
 NASA FMEA #: 05-6IC-MRL-7

NASA DATA:
 BASELINE []
 NEW [X]

SUBSYSTEM: RMS/EPD&C
 MDAC ID: 4318
 ITEM: RESISTOR, R2

LEAD ANALYST: ROBINSON

ASSESSMENT:

	CRITICALITY FLIGHT HDW/FUNC	REDUNDANCY SCREENS			CIL ITEM
		A	B	C	
NASA	[3 /1R]	[P]	[P]	[P]	[] *
IOA	[3 /2R]	[]	[NA]	[NA]	[]
COMPARE	[/N]	[N]	[N]	[N]	[]

RECOMMENDATIONS: (If different from NASA)

[/] [] [] [] []
 (ADD/DELETE)

* CIL RETENTION RATIONALE: (If applicable)

ADEQUATE []
 INADEQUATE []

REMARKS:

IOA CONCURS WITH NASA FMEA. UPGRADE IOA CRIT TO 3/1R AND CORRECT IOA SCREENS. SUBSEQUENT MULTIPLE FAILURES COULD CAUSE MOTOR BURNOUT AND COULD LEAD TO INABILITY TO SAFELY LATCH THE RMS AND SUBSEQUENT FAILURE OF THE GUILLOTINE/JETTISON SYSTEM WHICH COULD CAUSE LOSS OF CREW/VEHICLE. THIS ONE NASA FMEA CORRESPONDS TO THE FOLLOWING 12 IOA FMEAs: 4217, 4218, 4251, 4252, 4273, 4274, 4295, 4296, 4317, 4318, 4339 AND 4340. IOA RECOMMENDS COMBINING ALL LISTED IOA FMEAs INTO ONE TO ALLOW COMPARISON WITH NASA POST 51L FMEA.

APPENDIX C
ASSESSMENT WORKSHEET

ASSESSMENT DATE: 1/25/88
 ASSESSMENT ID: RMS-4319
 NASA FMEA #: 05-6IC-MRL-11

NASA DATA:
 BASELINE []
 NEW [X]

SUBSYSTEM: RMS/EPD&C
 MDAC ID: 4319
 ITEM: RESISTOR, R16

LEAD ANALYST: ROBINSON

ASSESSMENT:

	CRITICALITY FLIGHT HDW/FUNC	REDUNDANCY SCREENS			CIL ITEM
		A	B	C	
NASA	[3 / 3]	[]	[]	[]	[] *
IOA	[3 / 3]	[]	[]	[]	[]
COMPARE	[/]	[]	[]	[]	[]

RECOMMENDATIONS: (If different from NASA)

[/] [] [] [] []
 (ADD/DELETE)

* CIL RETENTION RATIONALE: (If applicable)

ADEQUATE []
 INADEQUATE []

REMARKS:

NO ISSUE. THE NASA FMEA ITEM IS "INDICATION CIRCUIT - HYBRID DRIVER TYPE 1, RESISTORS & EVENT INDICATION", AND INCLUDES SYSTEM 1 FWD/MID/AFT PEDESTAL CIRCUIT COMPONENTS. FOR COMPARISON, IOA RECOMMENDS COMBINING THE FOLLOWING IOA FMEAs: 4219 THRU 4234, 4253 THRU 4256, 4275 THRU 4278, 4297 THRU 4300, 4319 THRU 4322 AND 4341 THRU 4344. FMEAs WITH 3/3 CRIT DO NOT REQUIRE ASSESSMENT.

APPENDIX C
ASSESSMENT WORKSHEET

ASSESSMENT DATE: 1/25/88
 ASSESSMENT ID: RMS-4320
 NASA FMEA #: 05-6IC-MRL-11

NASA DATA:
 BASELINE []
 NEW [X]

SUBSYSTEM: RMS/EPD&C
 MDAC ID: 4320
 ITEM: RESISTOR, R64

LEAD ANALYST: ROBINSON

ASSESSMENT:

	CRITICALITY FLIGHT HDW/FUNC	REDUNDANCY SCREENS			CIL ITEM
		A	B	C	
NASA	[3 / 3]	[]	[]	[]	[] *
IOA	[3 / 3]	[]	[]	[]	[]
COMPARE	[/]	[]	[]	[]	[]

RECOMMENDATIONS: (If different from NASA)

[/] [] [] [] []
 (ADD/DELETE)

* CIL RETENTION RATIONALE: (If applicable)

ADEQUATE []
 INADEQUATE []

REMARKS:

NO ISSUE. THE NASA FMEA ITEM IS "INDICATION CIRCUIT - HYBRID DRIVER TYPE 1, RESISTORS & EVENT INDICATION", AND INCLUDES SYSTEM 1 FWD/MID/AFT PEDESTAL CIRCUIT COMPONENTS. FOR COMPARISON, IOA RECOMMENDS COMBINING THE FOLLOWING IOA FMEAs: 4219 THRU 4234, 4253 THRU 4256, 4275 THRU 4278, 4297 THRU 4300, 4319 THRU 4322 AND 4341 THRU 4344. FMEAs WITH 3/3 CRIT DO NOT REQUIRE ASSESSMENT.

APPENDIX C
ASSESSMENT WORKSHEET

ASSESSMENT DATE: 1/25/88
 ASSESSMENT ID: RMS-4321
 NASA FMEA #: 05-6IC-MRL-11

NASA DATA:
 BASELINE []
 NEW [X]

SUBSYSTEM: RMS/EPD&C
 MDAC ID: 4321
 ITEM: RESISTOR, R17

LEAD ANALYST: ROBINSON

ASSESSMENT:

	CRITICALITY FLIGHT HDW/FUNC	REDUNDANCY SCREENS			CIL ITEM
		A	B	C	
NASA	[3 / 3]	[]	[]	[]	[] *
IOA	[3 / 3]	[]	[]	[]	[]
COMPARE	[/]	[]	[]	[]	[]

RECOMMENDATIONS: (If different from NASA)

[/] [] [] [] []
 (ADD/DELETE)

* CIL RETENTION RATIONALE: (If applicable)

ADEQUATE []
 INADEQUATE []

REMARKS:

NO ISSUE. THE NASA FMEA ITEM IS "INDICATION CIRCUIT - HYBRID DRIVER TYPE 1, RESISTORS & EVENT INDICATION", AND INCLUDES SYSTEM 1 FWD/MID/AFT PEDESTAL CIRCUIT COMPONENTS. FOR COMPARISON, IOA RECOMMENDS COMBINING THE FOLLOWING IOA FMEAs: 4219 THRU 4234, 4253 THRU 4256, 4275 THRU 4278, 4297 THRU 4300, 4319 THRU 4322 AND 4341 THRU 4344. FMEAs WITH 3/3 CRIT DO NOT REQUIRE ASSESSMENT.

APPENDIX C
ASSESSMENT WORKSHEET

ASSESSMENT DATE: 1/25/88
 ASSESSMENT ID: RMS-4322
 NASA FMEA #: 05-6IC-MRL-11

NASA DATA:
 BASELINE []
 NEW [X]

SUBSYSTEM: RMS/EPD&C
 MDAC ID: 4322
 ITEM: RESISTOR, R65

LEAD ANALYST: ROBINSON

ASSESSMENT:

	CRITICALITY FLIGHT HDW/FUNC	REDUNDANCY SCREENS			CIL ITEM
		A	B	C	
NASA	[3 / 3]	[]	[]	[]	[] *
IOA	[3 / 3]	[]	[]	[]	[]
COMPARE	[/]	[]	[]	[]	[]

RECOMMENDATIONS: (If different from NASA)

[/] [] [] [] []
 (ADD/DELETE)

* CIL RETENTION RATIONALE: (If applicable)

ADEQUATE []
 INADEQUATE []

REMARKS:

NO ISSUE. THE NASA FMEA ITEM IS "INDICATION CIRCUIT - HYBRID DRIVER TYPE 1, RESISTORS & EVENT INDICATION", AND INCLUDES SYSTEM 1 FWD/MID/AFT PEDESTAL CIRCUIT COMPONENTS. FOR COMPARISON, IOA RECOMMENDS COMBINING THE FOLLOWING IOA FMEAs: 4219 THRU 4234, 4253 THRU 4256, 4275 THRU 4278, 4297 THRU 4300, 4319 THRU 4322 AND 4341 THRU 4344. FMEAs WITH 3/3 CRIT DO NOT REQUIRE ASSESSMENT.

APPENDIX C
ASSESSMENT WORKSHEET

ASSESSMENT DATE: 1/24/88
 ASSESSMENT ID: RMS-4323
 NASA FMEA #: 05-6IC-MRL-4

NASA DATA:
 BASELINE []
 NEW [X]

SUBSYSTEM: RMS/EPD&C
 MDAC ID: 4323
 ITEM: HYBRID RELAY, K24

LEAD ANALYST: ROBINSON

ASSESSMENT:

	CRITICALITY FLIGHT HDW/FUNC	REDUNDANCY SCREENS			CIL ITEM
		A	B	C	
NASA	[3 /1R]	[P]	[P]	[P]	[] *
IOA	[3 /2R]	[]	[NA]	[NA]	[]
COMPARE	[/N]	[N]	[N]	[N]	[]

RECOMMENDATIONS: (If different from NASA)

[/] [] [] [] []
 (ADD/DELETE)

* CIL RETENTION RATIONALE: (If applicable)

ADEQUATE []
 INADEQUATE []

REMARKS:

NO ISSUE.
 IOA CONCURS WITH THE POST 51L CRIT OF 3/1R. IOA SCREENS SHOULD BE 1-P-P. TO COMPARE WITH THE NASA FMEA, IOA RECOMMENDS COMBINING THE FOLLOWING 24 IOA FMEAs: 4201, 4203, 4205, 4207, 4235, 4237, 4239, 4241, 4257, 4259, 4261, 4263, 4279, 4281, 4283, 4285, 4301, 4303, 4305, 4307, 4323, 4325, 4327, AND 4329. THE IOA FMEAs ARE FOR 12 PORT AND 12 STARBOARD HYBRID RELAYS USED BY SYSTEM 1 AND SYSTEM 2, FWD, MID, AND AFT LATCH/RELEASE FOR BOTH PORT AND STARBOARD ARMS.

APPENDIX C
ASSESSMENT WORKSHEET

ASSESSMENT DATE: 1/30/88
 ASSESSMENT ID: RMS-4324
 NASA FMEA #: 05-6IC-MRL-5

NASA DATA:
 BASELINE []
 NEW [X]

SUBSYSTEM: RMS/EPD&C
 MDAC ID: 4324
 ITEM: HYBRID RELAY, K24

LEAD ANALYST: ROBINSON

ASSESSMENT:

	CRITICALITY FLIGHT HDW/FUNC	REDUNDANCY SCREENS			CIL ITEM
		A	B	C	
NASA	[3 /1R]	[P]	[P]	[P]	[] *
IOA	[3 /2R]	[]	[NA]	[NA]	[]
COMPARE	[/N]	[N]	[N]	[N]	[]

RECOMMENDATIONS: (If different from NASA)

[/] [] [] [] []
 (ADD/DELETE)

* CIL RETENTION RATIONALE: (If applicable)

ADEQUATE []
 INADEQUATE []

REMARKS:

NO ISSUE.

IOA CONCURS WITH THE POST 51L CRIT OF 3/1R. IOA SCREENS SHOULD BE 1 - P - P. IOA RECOMMENDS COMBINING THE FOLLOWING IOA FMEAs TO COMPARE WITH THE NASA FMEA. COMBINE THE FOLLOWING 12 IOA FMEAs: 4202, 4204, 4236, 4238, 4258, 4260, 4280, 4282, 4302, 4304, THE 12 IOA FMEAs ARE FOR 6 INDIVIDUAL PORT AND 6 INDIVIDUAL STARBOARD HYBRID RELAYS FOR LATCHING.

APPENDIX C
ASSESSMENT WORKSHEET

ASSESSMENT DATE: 1/24/88
 ASSESSMENT ID: RMS-4325
 NASA FMEA #: 05-6IC-MRL-4

NASA DATA:
 BASELINE []
 NEW [X]

SUBSYSTEM: RMS/EPD&C
 MDAC ID: 4325
 ITEM: HYBRID RELAY, K27

LEAD ANALYST: ROBINSON

ASSESSMENT:

	CRITICALITY FLIGHT HDW/FUNC	REDUNDANCY SCREENS			CIL ITEM
		A	B	C	
NASA	[3 /1R]	[P]	[P]	[P]	[] *
IOA	[3 /2R]	[]	[NA]	[NA]	[]
COMPARE	[/N]	[N]	[N]	[N]	[]

RECOMMENDATIONS: (If different from NASA)

[/] [] [] [] []
 (ADD/DELETE)

* CIL RETENTION RATIONALE: (If applicable)

ADEQUATE []
 INADEQUATE []

REMARKS:

NO ISSUE.

IOA CONCURS WITH THE POST 51L CRIT OF 3/1R. IOA SCREENS SHOULD BE 1-P-P. TO COMPARE WITH THE NASA FMEA, IOA RECOMMENDS COMBINING THE FOLLOWING 24 IOA FMEAs: 4201, 4203, 4205, 4207, 4235, 4237, 4239, 4241, 4257, 4259, 4261, 4263, 4279, 4281, 4283, 4285, 4301, 4303, 4305, 4307, 4323, 4325, 4327, AND 4329. THE IOA FMEAs ARE FOR 12 PORT AND 12 STARBOARD HYBRID RELAYS USED BY SYSTEM 1 AND SYSTEM 2, FWD, MID, AND AFT LATCH/RELEASE FOR BOTH PORT AND STARBOARD ARMS.

APPENDIX C
ASSESSMENT WORKSHEET

ASSESSMENT DATE: 1/30/88
 ASSESSMENT ID: RMS-4326
 NASA FMEA #: 05-6IC-MRL-5

NASA DATA:
 BASELINE []
 NEW [X]

SUBSYSTEM: RMS/EPD&C
 MDAC ID: 4326
 ITEM: HYBRID RELAY, K27

LEAD ANALYST: ROBINSON

ASSESSMENT:

	CRITICALITY FLIGHT HDW/FUNC	REDUNDANCY SCREENS			CIL ITEM
		A	B	C	
NASA	[3 /1R]	[P]	[P]	[P]	[] *
IOA	[3 /2R]	[]	[NA]	[NA]	[]
COMPARE	[/N]	[N]	[N]	[N]	[]

RECOMMENDATIONS: (If different from NASA)

[/] [] [] [] []
 (ADD/DELETE)

* CIL RETENTION RATIONALE: (If applicable)

ADEQUATE []
 INADEQUATE []

REMARKS:
 NO ISSUE.

IOA CONCURS WITH THE POST 51L CRIT OF 3/1R. IOA SCREENS SHOULD BE 1 - P - P. IOA RECOMMENDS COMBINING THE FOLLOWING IOA FMEAs TO COMPARE WITH THE NASA FMEA. COMBINE THE FOLLOWING 12 IOA FMEAs: 4202, 4204, 4236, 4238, 4258, 4260, 4280, 4282, 4302, 4304, THE 12 IOA FMEAs ARE FOR 6 INDIVIDUAL PORT AND 6 INDIVIDUAL STARBOARD HYBRID RELAYS FOR LATCHING.

APPENDIX C
ASSESSMENT WORKSHEET

ASSESSMENT DATE: 1/24/88
 ASSESSMENT ID: RMS-4327
 NASA FMEA #: 05-6IC-MRL-4

NASA DATA:
 BASELINE []
 NEW [X]

SUBSYSTEM: RMS/EPD&C
 MDAC ID: 4327
 ITEM: HYBRID RELAY, K12

LEAD ANALYST: ROBINSON

ASSESSMENT:

	CRITICALITY FLIGHT HDW/FUNC	REDUNDANCY SCREENS			CIL ITEM
		A	B	C	
NASA	[3 /1R]	[P]	[P]	[P]	[] *
IOA	[3 /2R]	[]	[NA]	[NA]	[]
COMPARE	[/N]	[N]	[N]	[N]	[]

RECOMMENDATIONS: (If different from NASA)

[/] [] [] [] []
 (ADD/DELETE)

* CIL RETENTION RATIONALE: (If applicable)

ADEQUATE []
 INADEQUATE []

REMARKS:

NO ISSUE.

IOA CONCURS WITH THE POST 51L CRIT OF 3/1R. IOA SCREENS SHOULD BE 1-P-P. TO COMPARE WITH THE NASA FMEA, IOA RECOMMENDS COMBINING THE FOLLOWING 24 IOA FMEAs: 4201, 4203, 4205, 4207, 4235, 4237, 4239, 4241, 4257, 4259, 4261, 4263, 4279, 4281, 4283, 4285, 4301, 4303, 4305, 4307, 4323, 4325, 4327, AND 4329. THE IOA FMEAs ARE FOR 12 PORT AND 12 STARBOARD HYBRID RELAYS USED BY SYSTEM 1 AND SYSTEM 2, FWD, MID, AND AFT LATCH/RELEASE FOR BOTH PORT AND STARBOARD ARMS.

APPENDIX C
ASSESSMENT WORKSHEET

ASSESSMENT DATE: 2/16/88
 ASSESSMENT ID: RMS-4328
 NASA FMEA #: 05-6IC-MRL-6

NASA DATA:
 BASELINE []
 NEW [X]

SUBSYSTEM: RMS/EPD&C
 MDAC ID: 4328
 ITEM: HYBRID RELAY, K12

LEAD ANALYST: ROBINSON

ASSESSMENT:

	CRITICALITY FLIGHT HDW/FUNC	REDUNDANCY SCREENS			CIL ITEM
		A	B	C	
NASA	[2 /1R]	[P]	[F]	[P]	[X] *
IOA	[3 /2R]	[]	[NA]	[NA]	[]
COMPARE	[N /N]	[N]	[N]	[N]	[N]

RECOMMENDATIONS: (If different from NASA)

[/] [] [] [] []
 (ADD/DELETE)

* CIL RETENTION RATIONALE: (If applicable)

ADEQUATE []
 INADEQUATE []

REMARKS:

NO ISSUE.

IOA CONCURS WITH THE POST 51L CRIT OF 3/1R. IOA SCREENS SHOULD BE 1 - P - P. IOA RECOMMENDS COMBINING THE FOLLOWING IOA FMEAS TO COMPARE WITH THE NASA FMEA. COMBINE THE FOLLOWING 6 IOA FMEAs: 4206, 4208, 4240, 4242, 4262, 4264, 4284, 4286, 4306, THE 12 IOA FMEAs ARE FOR 6 INDIVIDUAL PORT AND 6 INDIVIDUAL STARBOARD HYBRID RELAYS FOR RELEASING.

APPENDIX C
ASSESSMENT WORKSHEET

ASSESSMENT DATE: 1/24/88
 ASSESSMENT ID: RMS-4329
 NASA FMEA #: 05-6IC-MRL-4

NASA DATA:
 BASELINE []
 NEW [X]

SUBSYSTEM: RMS/EPD&C
 MDAC ID: 4329
 ITEM: HYBRID RELAY, K29

LEAD ANALYST: ROBINSON

ASSESSMENT:

	CRITICALITY FLIGHT HDW/FUNC	REDUNDANCY SCREENS			CIL ITEM
		A	B	C	
NASA	[3 /1R]	[P]	[P]	[P]	[] *
IOA	[3 /2R]	[]	[NA]	[NA]	[]
COMPARE	[/N]	[N]	[N]	[N]	[]

RECOMMENDATIONS: (If different from NASA)

[/] [] [] [] [] (ADD/DELETE)

* CIL RETENTION RATIONALE: (If applicable)

ADEQUATE []
 INADEQUATE []

REMARKS:

NO ISSUE.
 IOA CONCURS WITH THE POST 51L CRIT OF 3/1R. IOA SCREENS SHOULD BE 1-P-P. TO COMPARE WITH THE NASA FMEA, IOA RECOMMENDS COMBINING THE FOLLOWING 24 IOA FMEAs: 4201, 4203, 4205, 4207, 4235, 4237, 4239, 4241, 4257, 4259, 4261, 4263, 4279, 4281, 4283, 4285, 4301, 4303, 4305, 4307, 4323, 4325, 4327, AND 4329. THE IOA FMEAs ARE FOR 12 PORT AND 12 STARBOARD HYBRID RELAYS USED BY SYSTEM 1 AND SYSTEM 2, FWD, MID, AND AFT LATCH/RELEASE FOR BOTH PORT AND STARBOARD ARMS.

APPENDIX C
ASSESSMENT WORKSHEET

ASSESSMENT DATE: 2/16/88
 ASSESSMENT ID: RMS-4330
 NASA FMEA #: 05-6IC-MRL-6

NASA DATA:
 BASELINE []
 NEW [X]

SUBSYSTEM: RMS/EPD&C
 MDAC ID: 4330
 ITEM: HYBRID RELAY, K29

LEAD ANALYST: ROBINSON

ASSESSMENT:

	CRITICALITY FLIGHT HDW/FUNC	REDUNDANCY SCREENS			CIL ITEM
		A	B	C	
NASA	[2 /1R]	[P]	[F]	[P]	[X] *
IOA	[3 /2R]	[]	[NA]	[NA]	[]
COMPARE	[N /N]	[N]	[N]	[N]	[N]

RECOMMENDATIONS: (If different from NASA)

[/] [] [] [] []
 (ADD/DELETE)

* CIL RETENTION RATIONALE: (If applicable)

ADEQUATE []
 INADEQUATE []

REMARKS:
 NO ISSUE.

IOA CONCURS WITH THE POST 51L CRIT OF 3/1R. IOA SCREENS SHOULD BE 1 - P - P. IOA RECOMMENDS COMBINING THE FOLLOWING IOA FMEAS TO COMPARE WITH THE NASA FMEA. COMBINE THE FOLLOWING 6 IOA FMEAS: 4206, 4208, 4240, 4242, 4262, 4264, 4284, 4286, 4306, THE 12 IOA FMEAS ARE FOR 6 INDIVIDUAL PORT AND 6 INDIVIDUAL STARBOARD HYBRID RELAYS FOR RELEASING.

APPENDIX C
ASSESSMENT WORKSHEET

ASSESSMENT DATE: 2/14/88
 ASSESSMENT ID: RMS-4331
 NASA FMEA #: 05-6ID-2126-1

NASA DATA:
 BASELINE []
 NEW [X]

SUBSYSTEM: RMS/EPD&C
 MDAC ID: 4331
 ITEM: RELAY, K23

LEAD ANALYST: ROBINSON

ASSESSMENT:

	CRITICALITY FLIGHT HDW/FUNC	REDUNDANCY SCREENS			CIL ITEM
		A	B	C	
NASA	[2 /1R]	[P]	[P]	[P]	[X] *
IOA	[3 /2R]	[]	[NA]	[NA]	[]
COMPARE	[N /N]	[N]	[N]	[N]	[N]

RECOMMENDATIONS: (If different from NASA)

[/] [] [] [P] []
 (ADD/DELETE)

* CIL RETENTION RATIONALE: (If applicable)

ADEQUATE []
 INADEQUATE []

REMARKS:

NO ISSUE. RECOMMEND UPGRADING IOA FMEA TO CRITICALITY 2/1R.
 THE IOA FMEA FOR FAILURE OF THESE RELAYS WAS GENERATED AS PART OF
 THE MANIPULATOR RETENTION LATCH CONTROL CIRCUIT WHICH IS 05-6I
 SET OF NASA FMEAS ALSO AND THEREFORE THE RESULT OF THE FAILURES
 DO NOT MATCH WHEN COMPARED. THE RELAYS ARE 4 POLE, 2
 POSITION LATCHING RELAYS AND APPEAR IN BOTH THE LATCH CONTROL AND
 THE JETTISON/GUILLOTINE CIRCUITS. IOA CONCURS WITH THE NASA
 FAILURE.

APPENDIX C
ASSESSMENT WORKSHEET

ASSESSMENT DATE: 2/14/88
 ASSESSMENT ID: RMS-4332
 NASA FMEA #: 05-6ID-2129-1

NASA DATA:
 BASELINE [X]
 NEW []

SUBSYSTEM: RMS/EPD&C
 MDAC ID: 4332
 ITEM: RELAY, K17

LEAD ANALYST: ROBINSON

ASSESSMENT:

	CRITICALITY FLIGHT HDW/FUNC	REDUNDANCY SCREENS			CIL ITEM
		A	B	C	
NASA	[3 /3]	[P]	[P]	[P]	[] *
IOA	[3 /2R]	[P]	[NA]	[NA]	[]
COMPARE	[/N]	[]	[N]	[N]	[]

RECOMMENDATIONS: (If different from NASA)

[3 /2R] [] [] [P] []
 (ADD/DELETE)

* CIL RETENTION RATIONALE: (If applicable)

ADEQUATE []
 INADEQUATE []

REMARKS:

RECOMMEND UPGRADING THE NASA FMEA TO 3/2R. RECOMMEND COMBINING COMPONENTS IN IOA FMEAs 4266 AND 4332. THE IOA FMEA FOR FAILURE OF THESE RELAYS WAS GENERATED AS PART OF THE MANIPULATOR RETENTION LATCH CONTROL CIRCUIT WHICH IS 05-6I SET OF NASA FMEAS ALSO AND THEREFORE THE RESULT OF THE FAILURES DO NOT MATCH WHEN COMPARED. THE RELAYS ARE 4 POLE, 2 POSITION LATCHING RELAYS AND APPEAR IN BOTH THE LATCH CONTROL AND THE JETTISON/GUILLOTINE CIRCUITS. IOA CONCURS WITH THE NASA FAILURE.

APPENDIX C
ASSESSMENT WORKSHEET

ASSESSMENT DATE: 1/30/88
 ASSESSMENT ID: RMS-4333
 NASA FMEA #: 05-6IC-MRL-7A

NASA DATA:
 BASELINE []
 NEW [X]

SUBSYSTEM: RMS/EPD&C
 MDAC ID: 4333
 ITEM: FUSE, 2 AMP, F3

LEAD ANALYST: ROBINSON

ASSESSMENT:

	CRITICALITY FLIGHT HDW/FUNC	REDUNDANCY SCREENS			CIL ITEM
		A	B	C	
NASA	[3 /1R]	[P]	[P]	[P]	[] *
IOA	[3 /3]	[]	[]	[]	[]
COMPARE	[/N]	[N]	[N]	[N]	[]

RECOMMENDATIONS: (If different from NASA)

[/] [] [] [] []
 (ADD/DELETE)

* CIL RETENTION RATIONALE: (If applicable)

ADEQUATE []
 INADEQUATE []

REMARKS:

UPGRADE IOA CRIT TO 3/1R AND CORRECT IOA SCREENS. SUBSEQUENT MULTIPLE FAILURES COULD CAUSE MOTOR BURNOUT AND COULD LEAD TO INABILITY TO SAFELY LATCH THE RMS AND SUBSEQUENT FAILURE OF THE GUILLOTINE/JETTISON SYSTEM
 COULD RESULT IN LOSS OF CREW/VEHICLE. THIS ONE NASA FMEA CORRESPONDS TO THE FOLLOWING IOA FMEAs: 4211, 4212, 4245, 4246, 4267, 4268, 4289, 4290, 4311, 4312, 4333, AND 4334. IOA RECOMMENDS COMBINING ALL LISTED IOA FMEAs INTO ONE TO ALLOW COMPARISON WITH THE NASA POST 51L FMEA.

APPENDIX C
ASSESSMENT WORKSHEET

ASSESSMENT DATE: 1/30/88
 ASSESSMENT ID: RMS-4334
 NASA FMEA #: 05-6IC-MRL-7A

NASA DATA:
 BASELINE []
 NEW [X]

SUBSYSTEM: RMS/EPD&C
 MDAC ID: 4334
 ITEM: FUSE, 2 AMP, F3

LEAD ANALYST: ROBINSON

ASSESSMENT:

	CRITICALITY FLIGHT HDW/FUNC	REDUNDANCY SCREENS			CIL ITEM
		A	B	C	
NASA	[3 /1R]	[P]	[P]	[P]	[] *
IOA	[3 /3]	[]	[]	[]	[]
COMPARE	[/N]	[N]	[N]	[N]	[]

RECOMMENDATIONS: (If different from NASA)

[/] [] [] [] []
 (ADD/DELETE)

* CIL RETENTION RATIONALE: (If applicable)

ADEQUATE []
 INADEQUATE []

REMARKS:

UPGRADE IOA CRIT TO 3/1R AND CORRECT IOA SCREENS. SUBSEQUENT MULTIPLE FAILURES COULD CAUSE MOTOR BURNOUT AND COULD LEAD TO INABILITY TO SAFELY LATCH THE RMS AND SUBSEQUENT FAILURE OF THE GUILLOTINE/JETTISON SYSTEM COULD RESULT IN LOSS OF CREW/VEHICLE. THIS ONE NASA FMEA CORRESPONDS TO THE FOLLOWING IOA FMEAs: 4211, 4212, 4245, 4246, 4267, 4268, 4289, 4290, 4311, 4312, 4333, AND 4334. IOA RECOMMENDS COMBINING ALL LISTED IOA FMEAs INTO ONE TO ALLOW COMPARISON WITH THE NASA POST 51L FMEA.

APPENDIX C
ASSESSMENT WORKSHEET

ASSESSMENT DATE: 1/25/88
 ASSESSMENT ID: RMS-4335
 NASA FMEA #: 05-6IC-MRL-12

NASA DATA:
 BASELINE []
 NEW [X]

SUBSYSTEM: RMS/EPD&C
 MDAC ID: 4335
 ITEM: RESISTOR, R49

LEAD ANALYST: ROBINSON

ASSESSMENT:

	CRITICALITY FLIGHT HDW/FUNC	REDUNDANCY SCREENS			CIL ITEM
		A	B	C	
NASA	[3 / 3]	[N]	[N]	[N]	[] *
IOA	[3 / 3]	[]	[]	[]	[]
COMPARE	[/]	[N]	[N]	[N]	[]

RECOMMENDATIONS: (If different from NASA)

[/] [] [] [] []
 (ADD/DELETE)

* CIL RETENTION RATIONALE: (If applicable)

ADEQUATE []
 INADEQUATE []

REMARKS:

NO ISSUE. THE NASA FMEA ITEM IS THE "READY TO LATCH INDICATION CIRCUIT" WITH THE FAILURE MODE AS "ERRONEOUS INDICATION". THE IOA FMEAs ADDRESS THE INDIVIDUAL COMPONENTS. FOR COMPARISON PURPOSES, IOA RECOMMENDS COMBINING THE FOLLOWING IOA FMEAs: 4213 THRU 4216, 4247 THRU 4750, 4269 THRU 4272, 4291 THRU 4294, 4313 THRU 4316, AND 4335 THRU 4338.

APPENDIX C
ASSESSMENT WORKSHEET

ASSESSMENT DATE: 1/25/88
 ASSESSMENT ID: RMS-4336
 NASA FMEA #: 05-6IC-MRL-12

NASA DATA:
 BASELINE []
 NEW [X]

SUBSYSTEM: RMS/EPD&C
 MDAC ID: 4336
 ITEM: RESISTOR, R22

LEAD ANALYST: ROBINSON

ASSESSMENT:

	CRITICALITY FLIGHT HDW/FUNC	REDUNDANCY SCREENS			CIL ITEM
		A	B	C	
NASA	[3 / 3]	[N]	[N]	[N]	[] *
IOA	[3 / 3]	[]	[]	[]	[]
COMPARE	[/]	[N]	[N]	[N]	[]

RECOMMENDATIONS: (If different from NASA)

[/] [] [] [] []
 (ADD/DELETE)

* CIL RETENTION RATIONALE: (If applicable)

ADEQUATE []
 INADEQUATE []

REMARKS:

NO ISSUE. THE NASA FMEA ITEM IS THE "READY TO LATCH INDICATION CIRCUIT" WITH THE FAILURE MODE AS "ERRONEOUS INDICATION". THE IOA FMEAs ADDRESS THE INDIVIDUAL COMPONENTS. FOR COMPARISON PURPOSES, IOA RECOMMENDS COMBINING THE FOLLOWING IOA FMEAs: 4213 THRU 4216, 4247 THRU 4750, 4269 THRU 4272, 4291 THRU 4294, 4313 THRU 4316, AND 4335 THRU 4338.

APPENDIX C
ASSESSMENT WORKSHEET

ASSESSMENT DATE: 1/25/88
 ASSESSMENT ID: RMS-4337
 NASA FMEA #: 05-6IC-MRL-12

NASA DATA:
 BASELINE []
 NEW [X]

SUBSYSTEM: RMS/EPD&C
 MDAC ID: 4337
 ITEM: RESISTOR, R42

LEAD ANALYST: ROBINSON

ASSESSMENT:

	CRITICALITY FLIGHT HDW/FUNC	REDUNDANCY SCREENS			CIL ITEM
		A	B	C	
NASA	[3 / 3]	[N]	[N]	[N]	[] *
IOA	[3 / 3]	[]	[]	[]	[]
COMPARE	[/]	[N]	[N]	[N]	[]

RECOMMENDATIONS: (If different from NASA)

[/] [] [] [] []
 (ADD/DELETE)

* CIL RETENTION RATIONALE: (If applicable)

ADEQUATE []
 INADEQUATE []

REMARKS:

NO ISSUE. THE NASA FMEA ITEM IS THE "READY TO LATCH INDICATION CIRCUIT" WITH THE FAILURE MODE AS "ERRONEOUS INDICATION". THE IOA FMEAs ADDRESS THE INDIVIDUAL COMPONENTS. FOR COMPARISON PURPOSES, IOA RECOMMENDS COMBINING THE FOLLOWING IOA FMEAs: 4213 THRU 4216, 4247 THRU 4750, 4269 THRU 4272, 4291 THRU 4294, 4313 THRU 4316, AND 4337 AND 4338.

APPENDIX C
ASSESSMENT WORKSHEET

ASSESSMENT DATE: 1/25/88
 ASSESSMENT ID: RMS-4338
 NASA FMEA #: 05-6IC-MRL-12

NASA DATA:
 BASELINE []
 NEW [X]

SUBSYSTEM: RMS/EPD&C
 MDAC ID: 4338
 ITEM: RESISTOR, R23

LEAD ANALYST: ROBINSON

ASSESSMENT:

	CRITICALITY FLIGHT HDW/FUNC	REDUNDANCY SCREENS			CIL ITEM
		A	B	C	
NASA	[3 / 3]	[N]	[N]	[N]	[] *
IOA	[3 / 3]	[]	[]	[]	[]
COMPARE	[/]	[N]	[N]	[N]	[]

RECOMMENDATIONS: (If different from NASA)

[/] [] [] [] []
 (ADD/DELETE)

* CIL RETENTION RATIONALE: (If applicable)

ADEQUATE []
 INADEQUATE []

REMARKS:

NO ISSUE. THE NASA FMEA ITEM IS THE "READY TO LATCH INDICATION CIRCUIT" WITH THE FAILURE MODE AS "ERRONEOUS INDICATION". THE IOA FMEAs ADDRESS THE INDIVIDUAL COMPONENTS. FOR COMPARISON PURPOSES, IOA RECOMMENDS COMBINING THE FOLLOWING IOA FMEAs: 4213 THRU 4216, 4247 THRU 4750, 4269 THRU 4272, 4291 THRU 4294, 4313 THRU 4316, AND 4337 AND 4338.

APPENDIX C
ASSESSMENT WORKSHEET

ASSESSMENT DATE: 1/30/88
 ASSESSMENT ID: RMS-4339
 NASA FMEA #: 05-6IC-MRL-7

NASA DATA:
 BASELINE []
 NEW [X]

SUBSYSTEM: RMS/EPD&C
 MDAC ID: 4339
 ITEM: RESISTOR, R2

LEAD ANALYST: ROBINSON

ASSESSMENT:

	CRITICALITY FLIGHT HDW/FUNC	REDUNDANCY SCREENS			CIL ITEM
		A	B	C	
NASA	[3 /1R]	[P]	[P]	[P]	[] *
IOA	[3 /2R]	[]	[NA]	[NA]	[]
COMPARE	[/N]	[N]	[N]	[N]	[]

RECOMMENDATIONS: (If different from NASA)

[/] [] [] [] [] (ADD/DELETE)

* CIL RETENTION RATIONALE: (If applicable)

ADEQUATE []
 INADEQUATE []

REMARKS:

IOA CONCURS WITH NASA FMEA. UPGRADE IOA CRIT TO 3/1R AND CORRECT IOA SCREENS. SUBSEQUENT MULTIPLE FAILURES COULD CAUSE MOTOR BURNOUT AND COULD LEAD TO INABILITY TO SAFELY LATCH THE RMS AND SUBSEQUENT FAILURE OF THE GUILLOTINE/JETTISON SYSTEM WHICH COULD CAUSE LOSS OF CREW/VEHICLE. THIS ONE NASA FMEA CORRESPONDS TO THE FOLLOWING 12 IOA FMEAs: 4217, 4218, 4251, 4252, 4273, 4274, 4295, 4296, 4317, 4318, 4339 AND 4340. IOA RECOMMENDS COMBINING ALL LISTED IOA FMEAs INTO ONE TO ALLOW COMPARISON WITH NASA POST 51L FMEA.

APPENDIX C
ASSESSMENT WORKSHEET

ASSESSMENT DATE: 1/30/88
 ASSESSMENT ID: RMS-4340
 NASA FMEA #: 05-6IC-MRL-7

NASA DATA:
 BASELINE []
 NEW [X]

SUBSYSTEM: RMS/EPD&C
 MDAC ID: 4340
 ITEM: RESISTOR, R3

LEAD ANALYST: ROBINSON

ASSESSMENT:

	CRITICALITY FLIGHT HDW/FUNC	REDUNDANCY SCREENS			CIL ITEM
		A	B	C	
NASA	[3 /1R]	[P]	[P]	[P]	[] *
IOA	[3 /2R]	[]	[NA]	[NA]	[]
COMPARE	[/N]	[N]	[N]	[N]	[]

RECOMMENDATIONS: (If different from NASA)

[/] [] [] [] []
 (ADD/DELETE)

* CIL RETENTION RATIONALE: (If applicable)

ADEQUATE []
 INADEQUATE []

REMARKS:

IOA CONCURS WITH NASA FMEA. UPGRADE IOA CRIT TO 3/1R AND CORRECT IOA SCREENS. SUBSEQUENT MULTIPLE FAILURES COULD CAUSE MOTOR BURNOUT AND COULD LEAD TO INABILITY TO SAFELY LATCH THE RMS AND SUBSEQUENT FAILURE OF THE GUILLOTINE/JETTISON SYSTEM WHICH COULD CAUSE LOSS OF CREW/VEHICLE. THIS ONE NASA FMEA CORRESPONDS TO THE FOLLOWING 12 IOA FMEAs: 4217, 4218, 4251, 4252, 4273, 4274, 4295, 4296, 4317, 4318, 4339 AND 4340. IOA RECOMMENDS COMBINING ALL LISTED IOA FMEAs INTO ONE TO ALLOW COMPARISON WITH NASA POST 51L FMEA.

APPENDIX C
ASSESSMENT WORKSHEET

ASSESSMENT DATE: 1/25/88
 ASSESSMENT ID: RMS-4341
 NASA FMEA #: 05-6IC-MRL-11

NASA DATA:
 BASELINE []
 NEW [X]

SUBSYSTEM: RMS/EPD&C
 MDAC ID: 4341
 ITEM: RESISTOR, R34

LEAD ANALYST: ROBINSON

ASSESSMENT:

	CRITICALITY FLIGHT HDW/FUNC	REDUNDANCY SCREENS			CIL ITEM
		A	B	C	
NASA	[3 / 3]	[]	[]	[]	[] *
IOA	[3 / 3]	[]	[]	[]	[]
COMPARE	[/]	[]	[]	[]	[]

RECOMMENDATIONS: (If different from NASA)

[/] [] [] [] []
 (ADD/DELETE)

* CIL RETENTION RATIONALE: (If applicable)

ADEQUATE []
 INADEQUATE []

REMARKS:

NO ISSUE. THE NASA FMEA ITEM IS "INDICATION CIRCUIT - HYBRID DRIVER TYPE 1, RESISTORS & EVENT INDICATION", AND INCLUDES SYSTEM 1 FWD/MID/AFT PEDESTAL CIRCUIT COMPONENTS. FOR COMPARISON, IOA RECOMMENDS COMBINING THE FOLLOWING IOA FMEAs: 4219 THRU 4234, 4253 THRU 4256, 4275 THRU 4278, 4297 THRU 4300, 4319 THRU 4322 AND 4341 THRU 4344. FMEAs WITH 3/3 CRIT DO NOT REQUIRE ASSESSMENT.

APPENDIX C
ASSESSMENT WORKSHEET

ASSESSMENT DATE: 1/25/88
 ASSESSMENT ID: RMS-4342
 NASA FMEA #: 05-6IC-MRL-11

NASA DATA:
 BASELINE []
 NEW [X]

SUBSYSTEM: RMS/EPD&C
 MDAC ID: 4342
 ITEM: RESISTOR, R33

LEAD ANALYST: ROBINSON

ASSESSMENT:

	CRITICALITY FLIGHT HDW/FUNC	REDUNDANCY SCREENS			CIL ITEM
		A	B	C	
NASA	[3 / 3]	[]	[]	[]	[] *
IOA	[3 / 3]	[]	[]	[]	[]
COMPARE	[/]	[]	[]	[]	[]

RECOMMENDATIONS: (If different from NASA)

[/] [] [] [] []
 (ADD/DELETE)

* CIL RETENTION RATIONALE: (If applicable)

ADEQUATE []
 INADEQUATE []

REMARKS:

NO ISSUE. THE NASA FMEA ITEM IS "INDICATION CIRCUIT - HYBRID DRIVER TYPE 1, RESISTORS & EVENT INDICATION", AND INCLUDES SYSTEM 1 FWD/MID/AFT PEDESTAL CIRCUIT COMPONENTS. FOR COMPARISON, IOA RECOMMENDS COMBINING THE FOLLOWING IOA FMEAs: 4219 THRU 4234, 4253 THRU 4256, 4275 THRU 4278, 4297 THRU 4300, 4319 THRU 4322 AND 4341 THRU 4344. FMEAs WITH 3/3 CRIT DO NOT REQUIRE ASSESSMENT.

APPENDIX C
ASSESSMENT WORKSHEET

ASSESSMENT DATE: 1/25/88
 ASSESSMENT ID: RMS-4343
 NASA FMEA #: 05-6IC-MRL-11

NASA DATA:
 BASELINE []
 NEW [X]

SUBSYSTEM: RMS/EPD&C
 MDAC ID: 4343
 ITEM: RESISTOR, R36

LEAD ANALYST: ROBINSON

ASSESSMENT:

	CRITICALITY FLIGHT HDW/FUNC	REDUNDANCY SCREENS			CIL ITEM
		A	B	C	
NASA	[3 / 3]	[]	[]	[]	[] *
IOA	[3 / 3]	[]	[]	[]	[]
COMPARE	[/]	[]	[]	[]	[]

RECOMMENDATIONS: (If different from NASA)

[/] [] [] [] []
 (ADD/DELETE)

* CIL RETENTION RATIONALE: (If applicable)

ADEQUATE []
 INADEQUATE []

REMARKS:

NO ISSUE. THE NASA FMEA ITEM IS "INDICATION CIRCUIT - HYBRID DRIVER TYPE 1, RESISTORS & EVENT INDICATION", AND INCLUDES SYSTEM 1 FWD/MID/AFT PEDESTAL CIRCUIT COMPONENTS. FOR COMPARISON, IOA RECOMMENDS COMBINING THE FOLLOWING IOA FMEAs: 4219 THRU 4234, 4253 THRU 4256, 4275 THRU 4278, 4297 THRU 4300, 4319 THRU 4322 AND 4341 THRU 4344. FMEAs WITH 3/3 CRIT DO NOT REQUIRE ASSESSMENT.

APPENDIX C
ASSESSMENT WORKSHEET

ASSESSMENT DATE: 1/25/88
 ASSESSMENT ID: RMS-4344
 NASA FMEA #: 05-6IC-MRL-11

NASA DATA:
 BASELINE []
 NEW [X]

SUBSYSTEM: RMS/EPD&C
 MDAC ID: 4344
 ITEM: RESISTOR, R31

LEAD ANALYST: ROBINSON

ASSESSMENT:

	CRITICALITY FLIGHT HDW/FUNC	REDUNDANCY SCREENS			CIL ITEM
		A	B	C	
NASA	[3 / 3]	[]	[]	[]	[] *
IOA	[3 / 3]	[]	[]	[]	[]
COMPARE	[/]	[]	[]	[]	[]

RECOMMENDATIONS: (If different from NASA)

[/] [] [] [] []
 (ADD/DELETE)

* CIL RETENTION RATIONALE: (If applicable)

ADEQUATE []
 INADEQUATE []

REMARKS:

NO ISSUE. THE NASA FMEA ITEM IS "INDICATION CIRCUIT - HYBRID DRIVER TYPE 1, RESISTORS & EVENT INDICATION", AND INCLUDES SYSTEM 1 FWD/MID/AFT PEDESTAL CIRCUIT COMPONENTS. FOR COMPARISON, IOA RECOMMENDS COMBINING THE FOLLOWING IOA FMEAs: 4219 THRU 4234, 4253 THRU 4256, 4275 THRU 4278, 4297 THRU 4300, 4319 THRU 4322 AND 4341 THRU 4344. FMEAs WITH 3/3 CRIT DO NOT REQUIRE ASSESSMENT.

APPENDIX C
ASSESSMENT WORKSHEET

ASSESSMENT DATE: 2/18/88
 ASSESSMENT ID: RMS-4345X
 NASA FMEA #: 05-6IC-MRL-1

NASA DATA:
 BASELINE []
 NEW [X]

SUBSYSTEM: RMS/EPD&C
 MDAC ID: 4345
 ITEM: FUSE, F3, F4

LEAD ANALYST: ROBINSON

ASSESSMENT:

	CRITICALITY FLIGHT HDW/FUNC	REDUNDANCY SCREENS			CIL ITEM
		A	B	C	
NASA	[3 /1R]	[P]	[P]	[P]	[] *
IOA	[3 /1R]	[P]	[P]	[P]	[]
COMPARE	[/]	[]	[]	[]	[]

RECOMMENDATIONS: (If different from NASA)

[/] [] [] [] []
 (ADD/DELETE)

* CIL RETENTION RATIONALE: (If applicable)

ADEQUATE []
 INADEQUATE []

REMARKS:

NO ISSUE. IOA CONCURS WITH THE NASA POST 51L FMEA. IOA
 RECOMMENDS GENERATING A COMPARABLE FMEA FOR THESE COMPONENTS WITH
 THIS FAILURE MODE.

APPENDIX C
ASSESSMENT WORKSHEET

ASSESSMENT DATE: 2/18/88
 ASSESSMENT ID: RMS-4346X
 NASA FMEA #: 05-6IC-MRL-2A

NASA DATA:
 BASELINE []
 NEW [X]

SUBSYSTEM: RMS/EPD&C
 MDAC ID: 4346
 ITEM: SWITCH, S6

LEAD ANALYST: ROBINSON

ASSESSMENT:

	CRITICALITY FLIGHT HDW/FUNC	REDUNDANCY SCREENS			CIL ITEM
		A	B	C	
NASA	[2 /1R]	[P]	[P]	[P]	[X] *
IOA	[2 /1R]	[P]	[P]	[P]	[X]
COMPARE	[/]	[]	[]	[]	[]

RECOMMENDATIONS: (If different from NASA)

[/] [] [] [] []
 (ADD/DELETE)

* CIL RETENTION RATIONALE: (If applicable)

ADEQUATE []
 INADEQUATE []

REMARKS:

NO ISSUE. IOA CONCURS WITH THE NASA POST 51L FMEA. IOA RECOMMENDS GENERATING A COMPARABLE FMEA FOR THIS COMPONENT WITH THIS FAILURE MODE.
 IOA RECOMMENDS COMBINING NASA FMEAs 05-6IC-MRL-2A, 2E, AND 2F.

APPENDIX C
ASSESSMENT WORKSHEET

ASSESSMENT DATE: 2/18/88
 ASSESSMENT ID: RMS-4347X
 NASA FMEA #: 05-6IC-MRL-2B

NASA DATA:
 BASELINE []
 NEW [X]

SUBSYSTEM: RMS/EPD&C
 MDAC ID: 4347
 ITEM: SWITCH, S6

LEAD ANALYST: ROBINSON

ASSESSMENT:

	CRITICALITY FLIGHT HDW/FUNC	REDUNDANCY SCREENS			CIL ITEM
		A	B	C	
NASA	[2 /1R]	[P]	[P]	[P]	[X] *
IOA	[2 /1R]	[P]	[P]	[P]	[X]
COMPARE	[/]	[]	[]	[]	[]

RECOMMENDATIONS: (If different from NASA)

[/] [] [] [] []
 (ADD/DELETE)

* CIL RETENTION RATIONALE: (If applicable)

ADEQUATE []
 INADEQUATE []

REMARKS:

NO ISSUE. IOA CONCURS WITH THE NASA POST 51L FMEA. IOA RECOMMENDS GENERATING A COMPARABLE FMEA FOR THIS COMPONENT WITH THIS FAILURE MODE.
 IOA RECOMMENDS COMBINING NASA FMEAs 05-6IC-MRL-2B, -2D, AND -2G.

APPENDIX C
ASSESSMENT WORKSHEET

ASSESSMENT DATE: 2/18/88
 ASSESSMENT ID: RMS-4348X
 NASA FMEA #: 05-6IC-MRL-2C

NASA DATA:
 BASELINE []
 NEW [X]

SUBSYSTEM: RMS/EPD&C
 MDAC ID: 4348
 ITEM: SWITCH, S6

LEAD ANALYST: ROBINSON

ASSESSMENT:

	CRITICALITY FLIGHT HDW/FUNC	REDUNDANCY SCREENS			CIL ITEM
		A	B	C	
NASA	[3 / 3]	[P]	[P]	[P]	[] *
IOA	[3 / 3]	[]	[]	[]	[]
COMPARE	[/]	[N]	[N]	[N]	[]

RECOMMENDATIONS: (If different from NASA)

[/] [] [] [] []
 (ADD/DELETE)

* CIL RETENTION RATIONALE: (If applicable)

ADEQUATE []
 INADEQUATE []

REMARKS:

NO ISSUE. IOA CONCURS WITH THE NASA POST 51L FMEA. IOA RECOMMENDS GENERATING A COMPARABLE FMEA FOR THIS COMPONENT WITH THIS FAILURE MODE.

APPENDIX C
ASSESSMENT WORKSHEET

ASSESSMENT DATE: 2/18/88
 ASSESSMENT ID: RMS-4349X
 NASA FMEA #: 05-6IC-MRL-2D

NASA DATA:
 BASELINE []
 NEW [X]

SUBSYSTEM: RMS/EPD&C
 MDAC ID: 4349
 ITEM: SWITCH, S6

LEAD ANALYST: ROBINSON

ASSESSMENT:

	CRITICALITY FLIGHT HDW/FUNC	REDUNDANCY SCREENS			CIL ITEM
		A	B	C	
NASA	[2 /1R]	[P]	[P]	[P]	[X] *
IOA	[2 /1R]	[P]	[P]	[P]	[X]
COMPARE	[/]	[]	[]	[]	[]

RECOMMENDATIONS: (If different from NASA)

[/] [] [] [] []
 (ADD/DELETE)

* CIL RETENTION RATIONALE: (If applicable)

ADEQUATE []
 INADEQUATE []

REMARKS:

NO ISSUE. IOA CONCURS WITH THE NASA POST 51L FMEA. IOA RECOMMENDS GENERATING A COMPARABLE FMEA FOR THIS COMPONENT WITH THIS FAILURE MODE.
 IOA RECOMMENDS COMBINING NASA FMEAs 05-6IC-MRL-2B, -2D, AND -2G.

APPENDIX C
ASSESSMENT WORKSHEET

ASSESSMENT DATE: 2/18/88
 ASSESSMENT ID: RMS-4350X
 NASA FMEA #: 05-6IC-MRL-2E

NASA DATA:
 BASELINE []
 NEW [X]

SUBSYSTEM: RMS/EPD&C
 MDAC ID: 4350
 ITEM: SWITCH, S6

LEAD ANALYST: ROBINSON

ASSESSMENT:

	CRITICALITY FLIGHT HDW/FUNC	REDUNDANCY SCREENS			CIL ITEM
		A	B	C	
NASA	[2 /1R]	[P]	[P]	[P]	[X] *
IOA	[2 /1R]	[P]	[P]	[P]	[X]
COMPARE	[/]	[]	[]	[]	[]

RECOMMENDATIONS: (If different from NASA)

[/] [] [] [] []
 (ADD/DELETE)

* CIL RETENTION RATIONALE: (If applicable)

ADEQUATE []
 INADEQUATE []

REMARKS:

NO ISSUE. IOA CONCURS WITH THE NASA POST 51L FMEA. IOA RECOMMENDS GENERATING A COMPARABLE FMEA FOR THIS COMPONENT WITH THIS FAILURE MODE.
 IOA RECOMMENDS COMBINING NASA FMEAs 05-6IC-MRL-2A, 2E, AND 2F.

APPENDIX C
ASSESSMENT WORKSHEET

ASSESSMENT DATE: 2/18/88
 ASSESSMENT ID: RMS-4351X
 NASA FMEA #: 05-6IC-MRL-2F

NASA DATA:
 BASELINE []
 NEW [X]

SUBSYSTEM: RMS/EPD&C
 MDAC ID: 4351
 ITEM: SWITCH, S6

LEAD ANALYST: ROBINSON

ASSESSMENT:

	CRITICALITY FLIGHT HDW/FUNC	REDUNDANCY SCREENS			CIL ITEM
		A	B	C	
NASA	[2 /1R]	[P]	[P]	[P]	[X] *
IOA	[2 /1R]	[P]	[P]	[P]	[X]
COMPARE	[/]	[]	[]	[]	[]

RECOMMENDATIONS: (If different from NASA)

[/] [] [] [] [] (ADD/DELETE)

* CIL RETENTION RATIONALE: (If applicable)

ADEQUATE []
 INADEQUATE []

REMARKS:

NO ISSUE. IOA CONCURS WITH THE NASA POST 51L FMEA. IOA RECOMMENDS GENERATING A COMPARABLE FMEA FOR THIS COMPONENT WITH THIS FAILURE MODE.
 IOA RECOMMENDS COMBINING NASA FMEAs 05-6IC-MRL-2A, 2E, AND 2F.

APPENDIX C
ASSESSMENT WORKSHEET

ASSESSMENT DATE: 2/18/88
 ASSESSMENT ID: RMS-4352X
 NASA FMEA #: 05-6IC-MRL-2G

NASA DATA:
 BASELINE []
 NEW [X]

SUBSYSTEM: RMS/EPD&C
 MDAC ID: 4352
 ITEM: SWITCH, S6

LEAD ANALYST: ROBINSON

ASSESSMENT:

	CRITICALITY FLIGHT HDW/FUNC	REDUNDANCY SCREENS			CIL ITEM
		A	B	C	
NASA	[2 /1R]	[P]	[P]	[P]	[X] *
IOA	[2 /1R]	[P]	[P]	[P]	[X]
COMPARE	[/]	[]	[]	[]	[]

RECOMMENDATIONS: (If different from NASA)

[/] [] [] [] []
 (ADD/DELETE)

* CIL RETENTION RATIONALE: (If applicable)

ADEQUATE []
 INADEQUATE []

REMARKS:

NO ISSUE. IOA CONCURS WITH THE NASA POST 51L FMEA. IOA RECOMMENDS GENERATING A COMPARABLE FMEA FOR THIS COMPONENT WITH THIS FAILURE MODE.
 IOA RECOMMENDS COMBINING NASA FMEAs 05-6IC-MRL-2B, -2D, AND -2G.

APPENDIX C
ASSESSMENT WORKSHEET

ASSESSMENT DATE: 2/24/88
 ASSESSMENT ID: RMS-4353X
 NASA FMEA #: 05-6IC-MRL-8

NASA DATA:
 BASELINE []
 NEW [X]

SUBSYSTEM: RMS/EPD&C
 MDAC ID: 4353
 ITEM: LIMIT SWITCH - LATCHED & RELEASED

LEAD ANALYST: ROBINSON

ASSESSMENT:

	CRITICALITY FLIGHT HDW/FUNC	REDUNDANCY SCREENS			CIL ITEM
		A	B	C	
NASA	[3 /1R]	[P]	[P]	[P]	[] *
IOA	[3 /1R]	[P]	[P]	[P]	[]
COMPARE	[/]	[]	[]	[]	[]

RECOMMENDATIONS: (If different from NASA)

[/] [] [] [] []
 (ADD/DELETE)

* CIL RETENTION RATIONALE: (If applicable)

ADEQUATE []
 INADEQUATE []

REMARKS:

NO ISSUE. IOA CONCURS WITH NASA POST 51L FMEA. RECOMMEND IOA
 GENERATE A CORRESPONDING FMEA TO ALLOW ASSESSMENT.

APPENDIX C
ASSESSMENT WORKSHEET

ASSESSMENT DATE: 2/24/88
 ASSESSMENT ID: RMS-4354X
 NASA FMEA #: 05-6IC-MRL-9

NASA DATA:
 BASELINE []
 NEW [X]

SUBSYSTEM: RMS/EPD&C
 MDAC ID: 4354
 ITEM: LIMIT SWITCH - RELEASE

LEAD ANALYST: ROBINSON

ASSESSMENT:

	CRITICALITY FLIGHT HDW/FUNC	REDUNDANCY SCREENS			CIL ITEM
		A	B	C	
NASA	[3 /2R]	[P]	[P]	[P]	[] *
IOA	[3 /1R]	[P]	[P]	[P]	[]
COMPARE	[/N]	[]	[]	[]	[]

RECOMMENDATIONS: (If different from NASA)

[/] [] [] [] []
 (ADD/DELETE)

* CIL RETENTION RATIONALE: (If applicable)

ADEQUATE []
 INADEQUATE []

REMARKS:

NO ISSUE. IOA CONCURS WITH NASA POST 51L FMEA. RECOMMEND IOA GENERATE A CORRESPONDING FMEA TO ALLOW ASSESSMENT.

APPENDIX C
ASSESSMENT WORKSHEET

ASSESSMENT DATE: 2/24/88
 ASSESSMENT ID: RMS-4355X
 NASA FMEA #: 05-6IC-MRL-10

NASA DATA:
 BASELINE []
 NEW [X]

SUBSYSTEM: RMS/EPD&C
 MDAC ID: 4355
 ITEM: LIMIT SWITCH - LATCH

LEAD ANALYST: ROBINSON

ASSESSMENT:

	CRITICALITY FLIGHT HDW/FUNC	REDUNDANCY SCREENS			CIL ITEM
		A	B	C	
NASA	[3 /1R]	[P]	[P]	[P]	[] *
IOA	[3 /1R]	[P]	[P]	[P]	[]
COMPARE	[/]	[]	[]	[]	[]

RECOMMENDATIONS: (If different from NASA)

[/] [] [] [] []
 (ADD/DELETE)

* CIL RETENTION RATIONALE: (If applicable)

ADEQUATE []
 INADEQUATE []

REMARKS:

NO ISSUE. IOA CONCURS WITH NASA POST 51L FMEA. RECOMMEND IOA
 GENERATE A CORRESPONDING FMEA TO ALLOW ASSESSMENT.

APPENDIX C
ASSESSMENT WORKSHEET

ASSESSMENT DATE: 7/17/87
 ASSESSMENT ID: RMS-4501
 NASA FMEA #: 05-6ID-2036-1

NASA DATA:
 BASELINE [X]
 NEW []

SUBSYSTEM: RMS/EPD&C
 MDAC ID: 4501
 ITEM: SWITCH, S21

LEAD ANALYST: ROBINSON

ASSESSMENT:

	CRITICALITY FLIGHT HDW/FUNC	REDUNDANCY SCREENS			CIL ITEM
		A	B	C	
NASA	[1 /1]	[P]	[P]	[P]	[X] *
IOA	[1 /1]	[]	[]	[]	[X]
COMPARE	[/]	[N]	[N]	[N]	[]

RECOMMENDATIONS: (If different from NASA)

[/] [] [] [] []
 (ADD/DELETE)

* CIL RETENTION RATIONALE: (If applicable)

ADEQUATE []
 INADEQUATE []

REMARKS:

APPENDIX C
ASSESSMENT WORKSHEET

ASSESSMENT DATE: 7/17/87
 ASSESSMENT ID: RMS-4502
 NASA FMEA #: 05-6ID-2036-2

NASA DATA:
 BASELINE [X]
 NEW []

SUBSYSTEM: RMS/EPD&C
 MDAC ID: 4502
 ITEM: SWITCH, S21

LEAD ANALYST: ROBINSON

ASSESSMENT:

	CRITICALITY FLIGHT HDW/FUNC	REDUNDANCY SCREENS			CIL ITEM
		A	B	C	
NASA	[3 /1R]	[P]	[P]	[P]	[] *
IOA	[2 /1R]	[P]	[P]	[P]	[X]
COMPARE	[N /]	[]	[]	[]	[N]

RECOMMENDATIONS: (If different from NASA)

[/] [] [] [] [] (ADD/DELETE)

* CIL RETENTION RATIONALE: (If applicable)

ADEQUATE []
 INADEQUATE []

REMARKS:

THE SWITCH IS NOT NORMALLY ENERGIZED UNLESS IT IS READY TO BE USED. CIRCUIT BREAKERS AHEAD OF THE SWITCH IN THE CIRCUIT ARE NOT CLOSED WHEN THE RMS IS NOT IN USE, THEREFORE, IOA CONCURS THAT A FAILED CLOSED CONDITION FOR THIS SWITCH WOULD NOW WARRANT A 2/1R CRIT AND RECOMMENDS DOWNGRADING THE IOA CRIT TO 3/1R.

APPENDIX C
ASSESSMENT WORKSHEET

ASSESSMENT DATE: 1/12/88
 ASSESSMENT ID: RMS-4503
 NASA FMEA #: 05-6ID-2031-1

NASA DATA:
 BASELINE []
 NEW [X]

SUBSYSTEM: RMS/EPD&C
 MDAC ID: 4503
 ITEM: SWITCH, S28

LEAD ANALYST: ROBINSON

ASSESSMENT:

	CRITICALITY FLIGHT HDW/FUNC	REDUNDANCY SCREENS			CIL ITEM
		A	B	C	
NASA	[1 /1]	[]	[]	[]	[X] *
IOA	[1 /1]	[]	[]	[]	[X]
COMPARE	[/]	[]	[]	[]	[]

RECOMMENDATIONS: (If different from NASA)

[/] [] [] [] []
 (ADD/DELETE)

* CIL RETENTION RATIONALE: (If applicable)

ADEQUATE []
 INADEQUATE []

REMARKS:
 NONE

APPENDIX C
ASSESSMENT WORKSHEET

ASSESSMENT DATE: 7/17/87
 ASSESSMENT ID: RMS-4504
 NASA FMEA #: 05-6ID-2031-2

NASA DATA:
 BASELINE [X]
 NEW []

SUBSYSTEM: RMS/EPD&C
 MDAC ID: 4504
 ITEM: SWITCH, S28

LEAD ANALYST: ROBINSON

ASSESSMENT:

	CRITICALITY FLIGHT HDW/FUNC	REDUNDANCY SCREENS			CIL ITEM
		A	B	C	
NASA	[3 /1R]	[P]	[P]	[P]	[] *
IOA	[2 /1R]	[P]	[P]	[P]	[X]
COMPARE	[N /]	[]	[]	[]	[N]

RECOMMENDATIONS: (If different from NASA)

[/] [] [] [] []
 (ADD/DELETE)

* CIL RETENTION RATIONALE: (If applicable)

ADEQUATE []
 INADEQUATE []

REMARKS:

THE SWITCH IS NOT NORMALLY ENERGIZED UNLESS IT IS READY TO BE USED. CIRCUIT BREAKERS AHEAD OF THE SWITCH IN THE CIRCUIT ARE NOT CLOSED WHEN THE RMS IS NOT IN USE, THEREFORE, IOA CONCURS THAT A FAILED CLOSED CONDITION FOR THIS SWITCH WOULD NOW WARRANT A 2/1R CRIT AND RECOMMENDS DOWNGRADING THE IOA CRIT TO 3/1R.

APPENDIX C
ASSESSMENT WORKSHEET

ASSESSMENT DATE: 7/17/87
 ASSESSMENT ID: RMS-4505
 NASA FMEA #: 05-6ID-2032-1

NASA DATA:
 BASELINE [X]
 NEW []

SUBSYSTEM: RMS/EPD&C
 MDAC ID: 4505
 ITEM: SWITCH, S25

LEAD ANALYST: ROBINSON

ASSESSMENT:

	CRITICALITY FLIGHT HDW/FUNC	REDUNDANCY SCREENS			CIL ITEM
		A	B	C	
NASA	[1 / 1]	[P]	[P]	[P]	[X] *
IOA	[1 / 1]	[]	[]	[]	[X]
COMPARE	[/]	[N]	[N]	[N]	[]

RECOMMENDATIONS: (If different from NASA)

[/] [] [] [] []
 (ADD/DELETE)

* CIL RETENTION RATIONALE: (If applicable)

ADEQUATE []
 INADEQUATE []

REMARKS:

APPENDIX C
ASSESSMENT WORKSHEET

ASSESSMENT DATE: 7/17/87
 ASSESSMENT ID: RMS-4506
 NASA FMEA #: 05-6ID-2032-2

NASA DATA:
 BASELINE [X]
 NEW []

SUBSYSTEM: RMS/EPD&C
 MDAC ID: 4506
 ITEM: SWITCH, S25

LEAD ANALYST: ROBINSON

ASSESSMENT:

	CRITICALITY FLIGHT HDW/FUNC	REDUNDANCY SCREENS			CIL ITEM
		A	B	C	
NASA	[3 /1R]	[P]	[P]	[P]	[] *
IOA	[2 /1R]	[P]	[P]	[P]	[X]
COMPARE	[N /]	[]	[]	[]	[N]

RECOMMENDATIONS: (If different from NASA)

[/] [] [] [] [] (ADD/DELETE)

* CIL RETENTION RATIONALE: (If applicable)

ADEQUATE []
 INADEQUATE []

REMARKS:

THE SWITCH IS NOT NORMALLY ENERGIZED UNLESS IT IS READY TO BE USED. CIRCUIT BREAKERS AHEAD OF THE SWITCH IN THE CIRCUIT ARE NOT CLOSED WHEN THE RMS IS NOT IN USE, THEREFORE, IOA CONCURS THAT A FAILED CLOSED CONDITION FOR THIS SWITCH WOULD NOW WARRANT A 2/1R CRIT AND RECOMMENDS DOWNGRADING THE IOA CRIT TO 3/1R.

APPENDIX C
ASSESSMENT WORKSHEET

ASSESSMENT DATE: 1/12/88
 ASSESSMENT ID: RMS-4507
 NASA FMEA #: 05-6ID-2027-1

NASA DATA:
 BASELINE []
 NEW [X]

SUBSYSTEM: RMS/EPD&C
 MDAC ID: 4507
 ITEM: SWITCH, S32

LEAD ANALYST: ROBINSON

ASSESSMENT:

	CRITICALITY FLIGHT HDW/FUNC	REDUNDANCY SCREENS			CIL ITEM
		A	B	C	
NASA	[1 / 1]	[]	[]	[]	[X] *
IOA	[1 / 1]	[]	[]	[]	[X]
COMPARE	[/]	[]	[]	[]	[]

RECOMMENDATIONS: (If different from NASA)

[/] [] [] [] []
 (ADD/DELETE)

* CIL RETENTION RATIONALE: (If applicable)

ADEQUATE []
 INADEQUATE []

REMARKS:
 NONE

APPENDIX C
ASSESSMENT WORKSHEET

ASSESSMENT DATE: 1/12/88
 ASSESSMENT ID: RMS-4508
 NASA FMEA #: 05-6ID-2027-2

NASA DATA:
 BASELINE []
 NEW [X]

SUBSYSTEM: RMS/EPD&C
 MDAC ID: 4508
 ITEM: SWITCH, S32

LEAD ANALYST: ROBINSON

ASSESSMENT:

	CRITICALITY FLIGHT HDW/FUNC	REDUNDANCY SCREENS			CIL ITEM
		A	B	C	
NASA	[2 /1R]	[P]	[F]	[P]	[X] *
IOA	[2 /1R]	[P]	[P]	[P]	[X]
COMPARE	[/]	[]	[N]	[]	[]

RECOMMENDATIONS: (If different from NASA)

[/] [] [] [] [] (ADD/DELETE)

* CIL RETENTION RATIONALE: (If applicable)

ADEQUATE []
 INADEQUATE []

REMARKS:

RECOMMEND CHANGING IOA REDUNDANCY SCREEN B TO FAIL.

APPENDIX C
ASSESSMENT WORKSHEET

ASSESSMENT DATE: 7/17/87
 ASSESSMENT ID: RMS-4509
 NASA FMEA #: 05-6ID-2033-1

NASA DATA:
 BASELINE [X]
 NEW []

SUBSYSTEM: RMS/EPD&C
 MDAC ID: 4509
 ITEM: SWITCH, S24

LEAD ANALYST: ROBINSON

ASSESSMENT:

	CRITICALITY FLIGHT HDW/FUNC	REDUNDANCY SCREENS			CIL ITEM
		A	B	C	
NASA	[1 / 1]	[P]	[P]	[P]	[X] *
IOA	[1 / 1]	[]	[]	[]	[X]
COMPARE	[/]	[N]	[N]	[N]	[]

RECOMMENDATIONS: (If different from NASA)

[/] [] [] [] [] (ADD/DELETE)

* CIL RETENTION RATIONALE: (If applicable)

ADEQUATE []
 INADEQUATE []

REMARKS:

APPENDIX C
ASSESSMENT WORKSHEET

ASSESSMENT DATE: 7/17/87
 ASSESSMENT ID: RMS-4510
 NASA FMEA #: 05-6ID-2033-2

NASA DATA:
 BASELINE [X]
 NEW []

SUBSYSTEM: RMS/EPD&C
 MDAC ID: 4510
 ITEM: SWITCH, S24

LEAD ANALYST: ROBINSON

ASSESSMENT:

	CRITICALITY FLIGHT HDW/FUNC	REDUNDANCY SCREENS			CIL ITEM
		A	B	C	
NASA	[3 /1R]	[P]	[P]	[P]	[] *
IOA	[2 /1R]	[P]	[P]	[P]	[X]
COMPARE	[N /]	[]	[]	[]	[N]

RECOMMENDATIONS: (If different from NASA)

[/] [] [] [] []
 (ADD/DELETE)

* CIL RETENTION RATIONALE: (If applicable)

ADEQUATE []
 INADEQUATE []

REMARKS:

RECOMMEND DOWNGRADING IOA CRIT FROM 2/1R TO 3/1R.
 THE SWITCH IS NOT NORMALLY ENERGIZED UNLESS IT IS READY TO BE
 USED. CIRCUIT BREAKERS AHEAD OF THE SWITCH IN THE CIRCUIT ARE
 NOT CLOSED WHEN THE RMS IS NOT IN USE, THEREFORE, IOA CONCURS
 THAT A FAILED CLOSED CONDITION FOR THIS SWITCH WOULD NOW WARRANT
 A 2/1R CRIT.

APPENDIX C
ASSESSMENT WORKSHEET

ASSESSMENT DATE: 1/12/88
 ASSESSMENT ID: RMS-4511
 NASA FMEA #: 05-6ID-2028-1

NASA DATA:
 BASELINE []
 NEW [X]

SUBSYSTEM: RMS/EPD&C
 MDAC ID: 4511
 ITEM: SWITCH, S31

LEAD ANALYST: ROBINSON

ASSESSMENT:

	CRITICALITY FLIGHT HDW/FUNC	REDUNDANCY SCREENS			CIL ITEM
		A	B	C	
NASA	[1 / 1]	[]	[]	[]	[X] *
IOA	[1 / 1]	[]	[]	[]	[X]
COMPARE	[/]	[]	[]	[]	[]

RECOMMENDATIONS: (If different from NASA)

[/] [] [] [] []
 (ADD/DELETE)

* CIL RETENTION RATIONALE: (If applicable)

ADEQUATE []
 INADEQUATE []

REMARKS:
 NONE

APPENDIX C
ASSESSMENT WORKSHEET

ASSESSMENT DATE: 1/12/88
 ASSESSMENT ID: RMS-4512
 NASA FMEA #: 05-6ID-2028-2

NASA DATA:
 BASELINE []
 NEW [X]

SUBSYSTEM: RMS/EPD&C
 MDAC ID: 4512
 ITEM: SWITCH, S31

LEAD ANALYST: ROBINSON

ASSESSMENT:

	CRITICALITY FLIGHT HDW/FUNC	REDUNDANCY SCREENS			CIL ITEM
		A	B	C	
NASA	[2 /1R]	[P]	[F]	[P]	[X] *
IOA	[2 /1R]	[P]	[P]	[P]	[X]
COMPARE	[/]	[]	[N]	[]	[]

RECOMMENDATIONS: (If different from NASA)

[/] [] [] [] [] (ADD/DELETE)

* CIL RETENTION RATIONALE: (If applicable)

ADEQUATE []
 INADEQUATE []

REMARKS:

RECOMMEND CHANGING IOA REDUNDANCY SCREEN B TO FAIL.

APPENDIX C
ASSESSMENT WORKSHEET

ASSESSMENT DATE: 7/17/87
 ASSESSMENT ID: RMS-4513
 NASA FMEA #: 05-6ID-2034-1

NASA DATA:
 BASELINE [X]
 NEW []

SUBSYSTEM: RMS/EPD&C
 MDAC ID: 4513
 ITEM: SWITCH, S23

LEAD ANALYST: ROBINSON

ASSESSMENT:

	CRITICALITY FLIGHT HDW/FUNC	REDUNDANCY SCREENS			CIL ITEM
		A	B	C	
NASA	[1 / 1]	[P]	[P]	[P]	[X] *
IOA	[1 / 1]	[]	[]	[]	[X]
COMPARE	[/]	[N]	[N]	[N]	[]

RECOMMENDATIONS: (If different from NASA)

[/] [] [] [] []
 (ADD/DELETE)

* CIL RETENTION RATIONALE: (If applicable)

REMARKS:

ADEQUATE []
 INADEQUATE []

APPENDIX C
ASSESSMENT WORKSHEET

ASSESSMENT DATE: 7/17/87
 ASSESSMENT ID: RMS-4514
 NASA FMEA #: 05-6ID-2034-2

NASA DATA:
 BASELINE [X]
 NEW []

SUBSYSTEM: RMS/EPD&C
 MDAC ID: 4514
 ITEM: SWITCH, S23

LEAD ANALYST: ROBINSON

ASSESSMENT:

	CRITICALITY FLIGHT HDW/FUNC	REDUNDANCY SCREENS			CIL ITEM
		A	B	C	
NASA	[3 /1R]	[P]	[P]	[P]	[] *
IOA	[2 /1R]	[P]	[P]	[P]	[X]
COMPARE	[N /]	[]	[]	[]	[N]

RECOMMENDATIONS: (If different from NASA)

[/] [] [] [] []
 (ADD/DELETE)

* CIL RETENTION RATIONALE: (If applicable)

ADEQUATE []
 INADEQUATE []

REMARKS:

THE SWITCH IS NOT NORMALLY ENERGIZED UNLESS IT IS READY TO BE USED. CIRCUIT BREAKERS AHEAD OF THE SWITCH IN THE CIRCUIT ARE NOT CLOSED WHEN THE RMS IS NOT IN USE, THEREFORE, IOA CONCURS THAT A FAILED CLOSED CONDITION FOR THIS SWITCH WOULD NOW WARRANT A 2/1R CRIT AND RECOMMENDS DOWNGRADING THE IOA CRIT TO 3/1R.

APPENDIX C
ASSESSMENT WORKSHEET

ASSESSMENT DATE: 1/12/88
 ASSESSMENT ID: RMS-4515
 NASA FMEA #: 05-6ID-2029-1

NASA DATA:
 BASELINE []
 NEW [X]

SUBSYSTEM: RMS/EPD&C
 MDAC ID: 4515
 ITEM: SWITCH, S30

LEAD ANALYST: ROBINSON

ASSESSMENT:

	CRITICALITY FLIGHT HDW/FUNC	REDUNDANCY SCREENS			CIL ITEM
		A	B	C	
NASA	[1 /1]	[]	[]	[]	[X] *
IOA	[1 /1]	[]	[]	[]	[X]
COMPARE	[/]	[]	[]	[]	[]

RECOMMENDATIONS: (If different from NASA)

[/] [] [] [] []
 (ADD/DELETE)

* CIL RETENTION RATIONALE: (If applicable)

ADEQUATE []
 INADEQUATE []

REMARKS:
 NONE

APPENDIX C
ASSESSMENT WORKSHEET

ASSESSMENT DATE: 1/12/88
 ASSESSMENT ID: RMS-4516
 NASA FMEA #: 05-6ID-2029-2

NASA DATA:
 BASELINE []
 NEW [X]

SUBSYSTEM: RMS/EPD&C
 MDAC ID: 4516
 ITEM: SWITCH, S30

LEAD ANALYST: ROBINSON

ASSESSMENT:

	CRITICALITY FLIGHT HDW/FUNC	REDUNDANCY SCREENS			CIL ITEM
		A	B	C	
NASA	[2 /1R]	[P]	[F]	[P]	[X] *
IOA	[2 /1R]	[P]	[P]	[P]	[X]
COMPARE	[/]	[]	[N]	[]	[]

RECOMMENDATIONS: (If different from NASA)

[/] [] [] [] [] (ADD/DELETE)

* CIL RETENTION RATIONALE: (If applicable)

ADEQUATE []
 INADEQUATE []

REMARKS:

RECOMMEND CHANGING IOA REDUNDANCY SCREEN B TO FAIL.

APPENDIX C
ASSESSMENT WORKSHEET

ASSESSMENT DATE: 7/17/87
 ASSESSMENT ID: RMS-4517
 NASA FMEA #: 05-6ID-2035-1

NASA DATA:
 BASELINE [X]
 NEW []

SUBSYSTEM: RMS/EPD&C
 MDAC ID: 4517
 ITEM: SWITCH, S22

LEAD ANALYST: ROBINSON

ASSESSMENT:

	CRITICALITY FLIGHT HDW/FUNC	REDUNDANCY SCREENS			CIL ITEM
		A	B	C	
NASA	[1 / 1]	[P]	[P]	[P]	[X] *
IOA	[1 / 1]	[]	[]	[]	[X]
COMPARE	[/]	[N]	[N]	[N]	[]

RECOMMENDATIONS: (If different from NASA)

[/] [] [] [] []
 (ADD/DELETE)

* CIL RETENTION RATIONALE: (If applicable)

ADEQUATE []
 INADEQUATE []

REMARKS:

APPENDIX C
ASSESSMENT WORKSHEET

ASSESSMENT DATE: 7/17/87
 ASSESSMENT ID: RMS-4518
 NASA FMEA #: 05-6ID-2035-2

NASA DATA:
 BASELINE [X]
 NEW []

SUBSYSTEM: RMS/EPD&C
 MDAC ID: 4518
 ITEM: SWITCH, S22

LEAD ANALYST: ROBINSON

ASSESSMENT:

	CRITICALITY FLIGHT HDW/FUNC	REDUNDANCY SCREENS			CIL ITEM
		A	B	C	
NASA	[3 /1R]	[P]	[P]	[P]	[] *
IOA	[2 /1R]	[P]	[P]	[P]	[X]
COMPARE	[N /]	[]	[]	[]	[N]

RECOMMENDATIONS: (If different from NASA)

[/] [] [] [] []
 (ADD/DELETE)

* CIL RETENTION RATIONALE: (If applicable)

ADEQUATE []
 INADEQUATE []

REMARKS:

THE SWITCH IS NOT NORMALLY ENERGIZED UNLESS IT IS READY TO BE USED. CIRCUIT BREAKERS AHEAD OF THE SWITCH IN THE CIRCUIT ARE NOT CLOSED WHEN THE RMS IS NOT IN USE, THEREFORE, IOA CONCURS THAT A FAILED CLOSED CONDITION FOR THIS SWITCH WOULD NOW WARRANT A 2/1R CRIT AND RECOMMENDS DOWNGRADING THE IOA CRIT TO 3/1R.

APPENDIX C
ASSESSMENT WORKSHEET

ASSESSMENT DATE: 1/12/88
 ASSESSMENT ID: RMS-4519
 NASA FMEA #: 05-6ID-2030-1

NASA DATA:
 BASELINE []
 NEW [X]

SUBSYSTEM: RMS/EPD&C
 MDAC ID: 4519
 ITEM: SWITCH, S29

LEAD ANALYST: ROBINSON

ASSESSMENT:

	CRITICALITY	REDUNDANCY SCREENS			CIL ITEM
	FLIGHT HDW/FUNC	A	B	C	
NASA	[1 / 1]	[]	[]	[]	[X] *
IOA	[1 / 1]	[]	[]	[]	[X]
COMPARE	[/]	[]	[]	[]	[]

RECOMMENDATIONS: (If different from NASA)

[/] [] [] [] []
 (ADD/DELETE)

* CIL RETENTION RATIONALE: (If applicable)

ADEQUATE []
 INADEQUATE []

REMARKS:
 NONE

APPENDIX C
ASSESSMENT WORKSHEET

ASSESSMENT DATE: 1/12/88
 ASSESSMENT ID: RMS-4520
 NASA FMEA #: 05-6ID-2030-2

NASA DATA:
 BASELINE []
 NEW [X]

SUBSYSTEM: RMS/EPD&C
 MDAC ID: 4520
 ITEM: SWITCH, S29

LEAD ANALYST: ROBINSON

ASSESSMENT:

	CRITICALITY FLIGHT HDW/FUNC	REDUNDANCY SCREENS			CIL ITEM
		A	B	C	
NASA	[2 /1R]	[P]	[F]	[P]	[X] *
IOA	[2 /1R]	[P]	[P]	[P]	[X]
COMPARE	[/]	[]	[N]	[]	[]

RECOMMENDATIONS: (If different from NASA)

[/] [] [] [] []
 (ADD/DELETE)

* CIL RETENTION RATIONALE: (If applicable)

ADEQUATE []
 INADEQUATE []

REMARKS:
 NONE

APPENDIX C
ASSESSMENT WORKSHEET

ASSESSMENT DATE: 2/14/88
 ASSESSMENT ID: RMS-4521
 NASA FMEA #: 05-6ID-2026-1

NASA DATA:
 BASELINE []
 NEW [X]

SUBSYSTEM: RMS/EPD&C
 MDAC ID: 4521
 ITEM: SWITCH, S33

LEAD ANALYST: ROBINSON

ASSESSMENT:

	CRITICALITY FLIGHT HDW/FUNC	REDUNDANCY SCREENS			CIL ITEM
		A	B	C	
NASA	[1 / 1]	[]	[]	[]	[X] *
IOA	[3 / 3]	[]	[]	[]	[]
COMPARE	[N / N]	[]	[]	[]	[N]

RECOMMENDATIONS: (If different from NASA)

[/] [] [] [] []
 (ADD/DELETE)

* CIL RETENTION RATIONALE: (If applicable)

ADEQUATE []
 INADEQUATE []

REMARKS:

NO ISSUE. IOA CONCURS WITH NASA ANALYSIS,
 RECOMMEND UPGRADING IOA CRITICALITY AND ADDING TO CIL.

APPENDIX C
ASSESSMENT WORKSHEET

ASSESSMENT DATE: 7/17/87
 ASSESSMENT ID: RMS-4522
 NASA FMEA #: 05-6ID-2026-2

NASA DATA:
 BASELINE [X]
 NEW []

SUBSYSTEM: RMS/EPD&C
 MDAC ID: 4522
 ITEM: SWITCH, S33

LEAD ANALYST: ROBINSON

ASSESSMENT:

	CRITICALITY FLIGHT HDW/FUNC	REDUNDANCY SCREENS			CIL ITEM
		A	B	C	
NASA	[3 /2R]	[NA]	[NA]	[NA]	[] *
IOA	[3 /2R]	[P]	[P]	[P]	[]
COMPARE	[/]	[N]	[N]	[N]	[]

RECOMMENDATIONS: (If different from NASA)

[/] [] [] [] []
 (ADD/DELETE)

* CIL RETENTION RATIONALE: (If applicable)

ADEQUATE []
 INADEQUATE []

REMARKS:
 NONE

APPENDIX C
ASSESSMENT WORKSHEET

ASSESSMENT DATE: 2/14/88	NASA DATA:
ASSESSMENT ID: RMS-4523	BASELINE [X]
NASA FMEA #: 05-6ID-2001-1	NEW []

SUBSYSTEM: RMS/EPD&C
MDAC ID: 4523
ITEM: FUSE, F27

LEAD ANALYST: ROBINSON

ASSESSMENT:

	CRITICALITY FLIGHT HDW/FUNC	REDUNDANCY	SCREENS	CIL ITEM
		A	B	C
NASA	[3 / 3]	[NA]	[NA]	[NA]
IOA	[3 / 3]	[]	[]	[]
COMPARE	[/]	[N]	[N]	[N]

RECOMMENDATIONS: (If different from NASA)

[/]	[]	[]	[]	[]
-------	-----	-----	-----	-----

(ADD/DELETE)

* CIL RETENTION RATIONALE: (If applicable)

ADEQUATE	[]
INADEQUATE	[]

REMARKS:

IOA FMEA HAS TYPO IN "ITEM". SHOULD BE "F37" NOT "F27".

APPENDIX C
ASSESSMENT WORKSHEET

ASSESSMENT DATE: 2/14/88
 ASSESSMENT ID: RMS-4524
 NASA FMEA #: 05-6ID-2003-1

NASA DATA:
 BASELINE [X]
 NEW []

SUBSYSTEM: RMS/EPD&C
 MDAC ID: 4524
 ITEM: CIRCUIT BREAKER, CB27

LEAD ANALYST: ROBINSON

ASSESSMENT:

	CRITICALITY FLIGHT HDW/FUNC	REDUNDANCY SCREENS			CIL ITEM
		A	B	C	
NASA	[2 /1R]	[P]	[P]	[P]	[X] *
IOA	[2 /1R]	[P]	[P]	[P]	[X]
COMPARE	[/]	[]	[]	[]	[]

RECOMMENDATIONS: (If different from NASA)

[/] [] [] [] []
 (ADD/DELETE)

* CIL RETENTION RATIONALE: (If applicable)

ADEQUATE []
 INADEQUATE []

REMARKS:

COMBINE COMPONENTS IN IOA FMEAs 4524 AND 4528 TO AGREE WITH BASE COMPONENTS.

APPENDIX C
ASSESSMENT WORKSHEET

ASSESSMENT DATE: 2/14/88
 ASSESSMENT ID: RMS-4525
 NASA FMEA #: 05-6ID-2003-2

NASA DATA:
 BASELINE [X]
 NEW []

SUBSYSTEM: RMS/EPD&C
 MDAC ID: 4525
 ITEM: CIRCUIT BREAKER, CB27

LEAD ANALYST: ROBINSON

ASSESSMENT:

	CRITICALITY FLIGHT HDW/FUNC	REDUNDANCY SCREENS			CIL ITEM
		A	B	C	
NASA	[3 / 3]	[P]	[P]	[P]	[] *
IOA	[3 / 3]	[]	[]	[]	[]
COMPARE	[/]	[N]	[N]	[N]	[]

RECOMMENDATIONS: (If different from NASA)

[/] [] [] [] []
 (ADD/DELETE)

* CIL RETENTION RATIONALE: (If applicable)

ADEQUATE []
 INADEQUATE []

REMARKS:

COMBINE COMPONENTS IN IOA FMEAs 4525 AND 4529 TO AGREE WITH NASA
 BASE COMPONENTS.

APPENDIX C
ASSESSMENT WORKSHEET

ASSESSMENT DATE: 1/12/88
 ASSESSMENT ID: RMS-4526
 NASA FMEA #: 05-6ID-2002-1

NASA DATA:
 BASELINE []
 NEW [X]

SUBSYSTEM: RMS/EPD&C
 MDAC ID: 4526
 ITEM: CIRCUIT BREAKER, CB29

LEAD ANALYST: ROBINSON

ASSESSMENT:

	CRITICALITY FLIGHT HDW/FUNC	REDUNDANCY SCREENS			CIL ITEM
		A	B	C	
NASA	[1 /1]	[]	[]	[]	[X] *
IOA	[2 /1R]	[P]	[P]	[P]	[X]
COMPARE	[N /N]	[N]	[N]	[N]	[]

RECOMMENDATIONS: (If different from NASA)

[/] [] [] [] [] (ADD/DELETE)

* CIL RETENTION RATIONALE: (If applicable)

ADEQUATE []
 INADEQUATE []

REMARKS:

NO ISSUE. IOA CONCURS WITH THE NASA ANALYSIS.
 IOA RECOMMENDS UPGRADING THE IOA FMEA CRITICALITY AND ADDING THIS
 FAILURE MODE FOR THIS COMPONENT.

APPENDIX C
ASSESSMENT WORKSHEET

ASSESSMENT DATE: 2/14/88
 ASSESSMENT ID: RMS-4527
 NASA FMEA #: 05-6ID-2002-2

NASA DATA:
 BASELINE [X]
 NEW []

SUBSYSTEM: RMS/EPD&C
 MDAC ID: 4527
 ITEM: CIRCUIT BREAKER, CB29

LEAD ANALYST: ROBINSON

ASSESSMENT:

	CRITICALITY FLIGHT HDW/FUNC	REDUNDANCY SCREENS			CIL ITEM
		A	B	C	
NASA	[3 / 3]	[P]	[P]	[P]	[] *
IOA	[3 / 3]	[]	[]	[]	[]
COMPARE	[/]	[N]	[N]	[N]	[]

RECOMMENDATIONS: (If different from NASA)

[/] [] [] [] []
 (ADD/DELETE)

* CIL RETENTION RATIONALE: (If applicable)

ADEQUATE []
 INADEQUATE []

REMARKS:

COMBINE COMPONENTS IN IOA FMEAs 4527 AND 4531 TO AGREE WITH NASA
 BASE COMPONENTS.

APPENDIX C
ASSESSMENT WORKSHEET

ASSESSMENT DATE: 2/14/88
 ASSESSMENT ID: RMS-4528
 NASA FMEA #: 05-6ID-2003-1

NASA DATA:
 BASELINE [X]
 NEW []

SUBSYSTEM: RMS/EPD&C
 MDAC ID: 4528
 ITEM: CIRCUIT BREAKER, CB33

LEAD ANALYST: ROBINSON

ASSESSMENT:

	CRITICALITY FLIGHT HDW/FUNC	REDUNDANCY SCREENS			CIL ITEM
		A	B	C	
NASA	[2 /1R]	[P]	[P]	[P]	[X] *
IOA	[2 /1R]	[P]	[P]	[P]	[X]
COMPARE	[/]	[]	[]	[]	[]

RECOMMENDATIONS: (If different from NASA)

[/] [] [] [] []
 (ADD/DELETE)

* CIL RETENTION RATIONALE: (If applicable)

ADEQUATE []
 INADEQUATE []

REMARKS:

COMBINE COMPONENTS IN IOA FMEAs 4524 AND 4528 TO AGREE WITH BASE COMPONENTS.

APPENDIX C
ASSESSMENT WORKSHEET

ASSESSMENT DATE: 2/14/88	NASA DATA:
ASSESSMENT ID: RMS-4529	BASELINE [X]
NASA FMEA #: 05-6ID-2003-2	NEW []

SUBSYSTEM: RMS/EPD&C
 MDAC ID: 4529
 ITEM: CIRCUIT BREAKER, CB33

LEAD ANALYST: ROBINSON

ASSESSMENT:

	CRITICALITY FLIGHT HDW/FUNC	REDUNDANCY	SCREENS	CIL ITEM
		A	B	C
NASA	[3 / 3]	[P]	[P]	[P]
IOA	[3 / 3]	[]	[]	[]
COMPARE	[/]	[N]	[N]	[N]

RECOMMENDATIONS: (If different from NASA)

[/] [] [] [] []
 (ADD/DELETE)

* CIL RETENTION RATIONALE: (If applicable)

ADEQUATE []
 INADEQUATE []

REMARKS:

COMBINE COMPONENTS IN IOA FMEAs 4525 AND 4529 TO AGREE WITH NASA
 BASE COMPONENTS.

APPENDIX C
ASSESSMENT WORKSHEET

ASSESSMENT DATE: 2/14/88
 ASSESSMENT ID: RMS-4530
 NASA FMEA #: 05-6ID-2002A-1

NASA DATA:
 BASELINE []
 NEW [X]

SUBSYSTEM: RMS/EPD&C
 MDAC ID: 4530
 ITEM: CIRCUIT BREAKER, CB32

LEAD ANALYST: ROBINSON

ASSESSMENT:

	CRITICALITY FLIGHT HDW/FUNC	REDUNDANCY SCREENS			CIL ITEM
		A	B	C	
NASA	[2 /1R]	[P]	[F]	[P]	[X] *
IOA	[2 /1R]	[P]	[P]	[P]	[X]
COMPARE	[/]	[]	[N]	[]	[]

RECOMMENDATIONS: (If different from NASA)

[/] [] [] [] []
 (ADD/DELETE)

* CIL RETENTION RATIONALE: (If applicable)

ADEQUATE []
 INADEQUATE []

REMARKS:
 COMBINE COMPONENTS IN IOA FMEAS 4526 AND 4530 TO AGREE WITH BASE
 COMPONENTS.
 CORRECT IOA SCREEN B.

APPENDIX C
ASSESSMENT WORKSHEET

ASSESSMENT DATE: 2/14/88
 ASSESSMENT ID: RMS-4531
 NASA FMEA #: 05-6ID-2002-2

NASA DATA:
 BASELINE [X]
 NEW []

SUBSYSTEM: RMS/EPD&C
 MDAC ID: 4531
 ITEM: CIRCUIT BREAKER, CB32

LEAD ANALYST: ROBINSON

ASSESSMENT:

	CRITICALITY FLIGHT HDW/FUNC	REDUNDANCY SCREENS			CIL ITEM
		A	B	C	
NASA	[3 / 3]	[P]	[P]	[P]	[] *
IOA	[3 / 3]	[]	[]	[]	[]
COMPARE	[/]	[N]	[N]	[N]	[]

RECOMMENDATIONS: (If different from NASA)

[/] [] [] [] []
 (ADD/DELETE)

* CIL RETENTION RATIONALE: (If applicable)

ADEQUATE []
 INADEQUATE []

REMARKS:

COMBINE COMPONENTS IN IOA FMEAs 4527 AND 4531 TO AGREE WITH NASA
 BASE COMPONENTS.

APPENDIX C
ASSESSMENT WORKSHEET

ASSESSMENT DATE: 1/12/88
 ASSESSMENT ID: RMS-4532
 NASA FMEA #: 05-6ID-2507-1

NASA DATA:
 BASELINE []
 NEW [X]

SUBSYSTEM: RMS/EPD&C
 MDAC ID: 4532
 ITEM: PIC 1

LEAD ANALYST: ROBINSON

ASSESSMENT:

	CRITICALITY FLIGHT HDW/FUNC	REDUNDANCY SCREENS			CIL ITEM
		A	B	C	
NASA	[2 /1R]	[P]	[F]	[P]	[X] *
IOA	[2 /1R]	[P]	[P]	[P]	[X]
COMPARE	[/]	[]	[N]	[]	[]

RECOMMENDATIONS: (If different from NASA)

[/] [] [] [] [] (ADD/DELETE)

* CIL RETENTION RATIONALE: (If applicable)

ADEQUATE []
 INADEQUATE []

REMARKS:

IOA CONCURS. FAILURE DOES NOT PASS REDUNDANCY SCREEN B.
 RECOMMEND CHANGE IOA REDUNDANCY SCREEN B TO "F".
 RECOMMEND COMBINING IOA FMEAs TO AGREE WITH NASA FMEA.

APPENDIX C
ASSESSMENT WORKSHEET

ASSESSMENT DATE: 7/17/87
 ASSESSMENT ID: RMS-4533
 NASA FMEA #: 05-6ID-2515-1

NASA DATA:
 BASELINE [X]
 NEW []

SUBSYSTEM: RMS/EPD&C
 MDAC ID: 4533
 ITEM: PIC 1

LEAD ANALYST: ROBINSON

ASSESSMENT:

	CRITICALITY FLIGHT HDW/FUNC	REDUNDANCY SCREENS			CIL ITEM
		A	B	C	
NASA	[2 /1R]	[P]	[NA]	[P]	[X] *
IOA	[2 /1R]	[P]	[P]	[P]	[X]
COMPARE	[/]	[]	[N]	[]	[]

RECOMMENDATIONS: (If different from NASA)

[/] [] [] [] []
 (ADD/DELETE)

* CIL RETENTION RATIONALE: (If applicable)

ADEQUATE []
 INADEQUATE []

REMARKS:

FAILURE DOES NOT PASS REDUNDANCY SCREEN B. RECOMMEND CHANGE IOA AND NASA BASELINE REDUNDANCY SCREEN B TO "F".
 RECOMMEND COMBINING IOA FMEAs TO AGREE WITH NASA FMEA.

APPENDIX C
ASSESSMENT WORKSHEET

ASSESSMENT DATE: 1/12/88
 ASSESSMENT ID: RMS-4534
 NASA FMEA #: 05-6ID-2507-1

NASA DATA:
 BASELINE []
 NEW [X]

SUBSYSTEM: RMS/EPD&C
 MDAC ID: 4534
 ITEM: PIC 12

LEAD ANALYST: ROBINSON

ASSESSMENT:

	CRITICALITY FLIGHT HDW/FUNC	REDUNDANCY SCREENS			CIL ITEM
		A	B	C	
NASA	[2 /1R]	[P]	[F]	[P]	[X] *
IOA	[2 /1R]	[P]	[P]	[P]	[X]
COMPARE	[/]	[]	[N]	[]	[]

RECOMMENDATIONS: (If different from NASA)

[/] [] [] [] []
 (ADD/DELETE)

* CIL RETENTION RATIONALE: (If applicable)

ADEQUATE []
 INADEQUATE []

REMARKS:

IOA CONCURS. FAILURE DOES NOT PASS REDUNDANCY SCREEN B.
 RECOMMEND CHANGE IOA REDUNDANCY SCREEN B TO "F".
 RECOMMEND COMBINING IOA FMEAs TO AGREE WITH NASA FMEA.

APPENDIX C
ASSESSMENT WORKSHEET

ASSESSMENT DATE: 7/17/87
 ASSESSMENT ID: RMS-4535
 NASA FMEA #: 05-6ID-2515-1

NASA DATA:
 BASELINE [X]
 NEW []

SUBSYSTEM: RMS/EPD&C
 MDAC ID: 4535
 ITEM: PIC 12

LEAD ANALYST: ROBINSON

ASSESSMENT:

	CRITICALITY FLIGHT HDW/FUNC	REDUNDANCY SCREENS			CIL ITEM
		A	B	C	
NASA	[2 /1R]	[P]	[NA]	[P]	[X] *
IOA	[2 /1R]	[P]	[P]	[P]	[X]
COMPARE	[/]	[]	[N]	[]	[]

RECOMMENDATIONS: (If different from NASA)

[/] [] [] [] []
 (ADD/DELETE)

* CIL RETENTION RATIONALE: (If applicable)

ADEQUATE []
 INADEQUATE []

REMARKS:

FAILURE DOES NOT PASS REDUNDANCY SCREEN B. RECOMMEND CHANGE IOA AND NASA BASELINE REDUNDANCY SCREEN B TO "F".
 RECOMMEND COMBINING IOA FMEAs TO AGREE WITH NASA FMEA.

APPENDIX C
ASSESSMENT WORKSHEET

ASSESSMENT DATE: 2/15/88
 ASSESSMENT ID: RMS-4536
 NASA FMEA #: 05-6ID-2507-2

NASA DATA:
 BASELINE [X]
 NEW []

SUBSYSTEM: RMS/EPD&C
 MDAC ID: 4536
 ITEM: PIC 1, 12

LEAD ANALYST: ROBINSON

ASSESSMENT:

	CRITICALITY FLIGHT HDW/FUNC	REDUNDANCY SCREENS			CIL ITEM
		A	B	C	
NASA	[3 /1R]	[P]	[P]	[P]	[] *
IOA	[2 /1R]	[P]	[P]	[P]	[X]
COMPARE	[N /]	[]	[]	[]	[N]

RECOMMENDATIONS: (If different from NASA)

[/] [] [] [P] []
 (ADD/DELETE)

* CIL RETENTION RATIONALE: (If applicable)

ADEQUATE []
 INADEQUATE []

REMARKS:

NO ISSUE. AFTER FURTHER ANALYSIS IOA RECOMMENDS DOWNGRADING THE IOA CRIT TO 3/1R AND DELETING THIS FMEA FROM THE IOA CIL LIST. NOMINALLY FOR A PIC TO ARM AND FIRE PREMATURELY, AN "ARM", "FIRE 1", AND A "FIRE 2" ARE REQUIRED. IOA RECOMMENDS COMBINING THE COMPONENTS OF IOA FMEAS 4560 AND 4561.

APPENDIX C
ASSESSMENT WORKSHEET

ASSESSMENT DATE: 2/15/88
 ASSESSMENT ID: RMS-4537
 NASA FMEA #: 05-6ID-2515-2

NASA DATA:
 BASELINE [X]
 NEW []

SUBSYSTEM: RMS/EPD&C
 MDAC ID: 4537
 ITEM: PIC 1, 12

LEAD ANALYST: ROBINSON

ASSESSMENT:

	CRITICALITY FLIGHT HDW/FUNC	REDUNDANCY SCREENS			CIL ITEM
		A	B	C	
NASA	[3 /1R]	[P]	[P]	[P]	[X] *
IOA	[2 /1R]	[P]	[P]	[P]	[X]
COMPARE	[N /]	[]	[]	[]	[]

RECOMMENDATIONS: (If different from NASA)

[/] [] [] [P] []
 (ADD/DELETE)

* CIL RETENTION RATIONALE: (If applicable)

ADEQUATE []
 INADEQUATE []

REMARKS:

NO ISSUE. AFTER FURTHER ANALYSIS IOA RECOMMENDS DOWNGRADING THE IOA CRIT TO 3/1R AND DELETING THIS FMEA FROM THE IOA CIL LIST. NOMINALLY FOR A PIC TO ARM AND FIRE PREMATURELY, AN "ARM", "FIRE 1", AND A "FIRE 2" ARE REQUIRED. IOA RECOMMENDS COMBINING THE COMPONENTS OF IOA FMEAs 4536 AND 4537.

APPENDIX C
ASSESSMENT WORKSHEET

ASSESSMENT DATE: 1/12/88
 ASSESSMENT ID: RMS-4538
 NASA FMEA #: 05-6ID-2505-1

NASA DATA:
 BASELINE []
 NEW [X]

SUBSYSTEM: RMS/EPD&C
 MDAC ID: 4538
 ITEM: PIC 6

LEAD ANALYST: ROBINSON

ASSESSMENT:

	CRITICALITY FLIGHT HDW/FUNC	REDUNDANCY SCREENS			CIL ITEM
		A	B	C	
NASA	[2 /1R]	[P]	[F]	[P]	[X] *
IOA	[2 /1R]	[P]	[P]	[P]	[X]
COMPARE	[/]	[]	[N]	[]	[]

RECOMMENDATIONS: (If different from NASA)

[/] [] [] [] []
 (ADD/DELETE)

* CIL RETENTION RATIONALE: (If applicable)

ADEQUATE []
 INADEQUATE []

REMARKS:

IOA CONCURS. FAILURE DOES NOT PASS REDUNDANCY SCREEN B.
 RECOMMEND CHANGE IOA REDUNDANCY SCREEN B TO "F".
 RECOMMEND COMBINING IOA FMEAs TO AGREE WITH NASA FMEA.

APPENDIX C
ASSESSMENT WORKSHEET

ASSESSMENT DATE: 7/17/87
 ASSESSMENT ID: RMS-4539
 NASA FMEA #: 05-6ID-2513-1

NASA DATA:
 BASELINE [X]
 NEW []

SUBSYSTEM: RMS/EPD&C
 MDAC ID: 4539
 ITEM: PIC 6

LEAD ANALYST: ROBINSON

ASSESSMENT:

	CRITICALITY FLIGHT HDW/FUNC	REDUNDANCY SCREENS			CIL ITEM
		A	B	C	
NASA	[2 /1R]	[P]	[NA]	[P]	[X] *
IOA	[2 /1R]	[P]	[P]	[P]	[X]
COMPARE	[/]	[]	[N]	[]	[]

RECOMMENDATIONS: (If different from NASA)

[/] [] [] [] []
 (ADD/DELETE)

* CIL RETENTION RATIONALE: (If applicable)

ADEQUATE []
 INADEQUATE []

REMARKS:

FAILURE DOES NOT PASS REDUNDANCY SCREEN B. RECOMMEND CHANGE IOA AND NASA BASELINE REDUNDANCY SCREEN B TO "F".
 RECOMMEND COMBINING IOA FMEAs TO AGREE WITH NASA FMEA.

APPENDIX C
ASSESSMENT WORKSHEET

ASSESSMENT DATE: 1/12/88
 ASSESSMENT ID: RMS-4540
 NASA FMEA #: 05-6ID-2505-1

NASA DATA:
 BASELINE []
 NEW [X]

SUBSYSTEM: RMS/EPD&C
 MDAC ID: 4540
 ITEM: PIC 17

LEAD ANALYST: ROBINSON

ASSESSMENT:

	CRITICALITY FLIGHT HDW/FUNC	REDUNDANCY SCREENS			CIL ITEM
		A	B	C	
NASA	[2 /1R]	[P]	[F]	[P]	[X] *
IOA	[2 /1R]	[P]	[P]	[P]	[X]
COMPARE	[/]	[]	[N]	[]	[]

RECOMMENDATIONS: (If different from NASA)

[/] [] [] [] []
 (ADD/DELETE)

* CIL RETENTION RATIONALE: (If applicable)

ADEQUATE []
 INADEQUATE []

REMARKS:

IOA CONCURS. FAILURE DOES NOT PASS REDUNDANCY SCREEN B.
 RECOMMEND CHANGE IOA REDUNDANCY SCREEN B TO "F".
 RECOMMEND COMBINING IOA FMEAs TO AGREE WITH NASA FMEA.

APPENDIX C
ASSESSMENT WORKSHEET

ASSESSMENT DATE: 7/17/87
 ASSESSMENT ID: RMS-4541
 NASA FMEA #: 05-6ID-2513-1

NASA DATA:
 BASELINE [X]
 NEW []

SUBSYSTEM: RMS/EPD&C
 MDAC ID: 4541
 ITEM: PIC 17

LEAD ANALYST: ROBINSON

ASSESSMENT:

	CRITICALITY FLIGHT HDW/FUNC	REDUNDANCY SCREENS			CIL ITEM
		A	B	C	
NASA	[2 /1R]	[P]	[NA]	[P]	[X] *
IOA	[2 /1R]	[P]	[P]	[P]	[X]
COMPARE	[/]	[]	[N]	[]	[]

RECOMMENDATIONS: (If different from NASA)

[/] [] [] [] []
 (ADD/DELETE)

* CIL RETENTION RATIONALE: (If applicable)

ADEQUATE []
 INADEQUATE []

REMARKS:

FAILURE DOES NOT PASS REDUNDANCY SCREEN B. RECOMMEND CHANGE IOA AND NASA BASELINE REDUNDANCY SCREEN B TO "F".
 RECOMMEND COMBINING IOA FMEAs TO AGREE WITH NASA FMEA.

APPENDIX C
ASSESSMENT WORKSHEET

ASSESSMENT DATE: 2/15/88
 ASSESSMENT ID: RMS-4542
 NASA FMEA #: 05-6ID-2505-2

NASA DATA:
 BASELINE [X]
 NEW []

SUBSYSTEM: RMS/EPD&C
 MDAC ID: 4542
 ITEM: PIC 6, 17

LEAD ANALYST: ROBINSON

ASSESSMENT:

	CRITICALITY FLIGHT HDW/FUNC	REDUNDANCY SCREENS			CIL ITEM
		A	B	C	
NASA	[3 /1R]	[P]	[P]	[P]	[] *
IOA	[2 /1R]	[P]	[P]	[P]	[X]
COMPARE	[N /]	[]	[]	[]	[N]

RECOMMENDATIONS: (If different from NASA)

[/] [] [] [P] []
 (ADD/DELETE)

* CIL RETENTION RATIONALE: (If applicable)

ADEQUATE []
 INADEQUATE []

REMARKS:

NO ISSUE. AFTER FURTHER ANALYSIS IOA RECOMMENDS DOWNGRADING THE IOA CRIT TO 3/1R AND DELETING THIS FMEA FROM THE IOA CIL LIST. NOMINALLY FOR A PIC TO ARM AND FIRE PREMATURELY, AN "ARM", "FIRE 1", AND A "FIRE 2" ARE REQUIRED. IOA RECOMMENDS COMBINING THE COMPONENTS OF IOA FMEAs 4542 AND 4543.

APPENDIX C
ASSESSMENT WORKSHEET

ASSESSMENT DATE: 2/15/88
 ASSESSMENT ID: RMS-4543
 NASA FMEA #: 05-6ID-2513-2

NASA DATA:
 BASELINE [X]
 NEW []

SUBSYSTEM: RMS/EPD&C
 MDAC ID: 4543
 ITEM: PIC 6, 17

LEAD ANALYST: ROBINSON

ASSESSMENT:

	CRITICALITY FLIGHT HDW/FUNC	REDUNDANCY SCREENS			CIL ITEM
		A	B	C	
NASA	[3 /1R]	[P]	[P]	[P]	[] *
IOA	[2 /1R]	[P]	[P]	[P]	[X]
COMPARE	[N /]	[]	[]	[]	[N]

RECOMMENDATIONS: (If different from NASA)

[/] [] [] [P] []
 (ADD/DELETE)

* CIL RETENTION RATIONALE: (If applicable)

ADEQUATE []
 INADEQUATE []

REMARKS:

NO ISSUE. AFTER FURTHER ANALYSIS IOA RECOMMENDS DOWNGRADING THE IOA CRIT TO 3/1R AND DELETING THIS FMEA FROM THE IOA CIL LIST. NOMINALLY FOR A PIC TO ARM AND FIRE PREMATURELY, AN "ARM", "FIRE 1", AND A "FIRE 2" ARE REQUIRED. IOA RECOMMENDS COMBINING THE COMPONENTS OF IOA FMEAs 4542 AND 4543.

APPENDIX C
ASSESSMENT WORKSHEET

ASSESSMENT DATE: 1/12/88
 ASSESSMENT ID: RMS-4544
 NASA FMEA #: 05-6ID-2503-1

NASA DATA:
 BASELINE []
 NEW [X]

SUBSYSTEM: RMS/EPD&C
 MDAC ID: 4544
 ITEM: PIC 8

LEAD ANALYST: ROBINSON

ASSESSMENT:

	CRITICALITY FLIGHT HDW/FUNC	REDUNDANCY SCREENS			CIL ITEM
		A	B	C	
NASA	[2 /1R]	[P]	[F]	[P]	[X] *
IOA	[2 /1R]	[P]	[P]	[P]	[X]
COMPARE	[/]	[]	[N]	[]	[]

RECOMMENDATIONS: (If different from NASA)

[/] [] [] [] []
 (ADD/DELETE)

* CIL RETENTION RATIONALE: (If applicable)

ADEQUATE []
 INADEQUATE []

REMARKS:

IOA CONCURS. FAILURE DOES NOT PASS REDUNDANCY SCREEN B.
 RECOMMEND CHANGE IOA REDUNDANCY SCREEN B TO "F".
 RECOMMEND COMBINING IOA FMEAs TO AGREE WITH NASA FMEA.

APPENDIX C
ASSESSMENT WORKSHEET

ASSESSMENT DATE: 7/17/87
 ASSESSMENT ID: RMS-4545
 NASA FMEA #: 05-6ID-2511-1

NASA DATA:
 BASELINE [X]
 NEW []

SUBSYSTEM: RMS/EPD&C
 MDAC ID: 4545
 ITEM: PIC 8

LEAD ANALYST: ROBINSON

ASSESSMENT:

	CRITICALITY FLIGHT HDW/FUNC	REDUNDANCY SCREENS			CIL ITEM
		A	B	C	
NASA	[2 /1R]	[P]	[NA]	[P]	[X] *
IOA	[2 /1R]	[P]	[P]	[P]	[X]
COMPARE	[/]	[]	[N]	[]	[]

RECOMMENDATIONS: (If different from NASA)

[/] [] [] [] []
 (ADD/DELETE)

* CIL RETENTION RATIONALE: (If applicable)

ADEQUATE []
 INADEQUATE []

REMARKS:

FAILURE DOES NOT PASS REDUNDANCY SCREEN B. RECOMMEND CHANGE IOA AND NASA BASELINE REDUNDANCY SCREEN B TO "F".
 RECOMMEND COMBINING IOA FMEAs TO AGREE WITH NASA FMEA.

APPENDIX C
ASSESSMENT WORKSHEET

ASSESSMENT DATE: 1/12/88
 ASSESSMENT ID: RMS-4546
 NASA FMEA #: 05-6ID-2503-1

NASA DATA:
 BASELINE []
 NEW [X]

SUBSYSTEM: RMS/EPD&C
 MDAC ID: 4546
 ITEM: PIC 19

LEAD ANALYST: ROBINSON

ASSESSMENT:

	CRITICALITY FLIGHT HDW/FUNC	REDUNDANCY SCREENS			CIL ITEM
		A	B	C	
NASA	[2 /1R]	[P]	[F]	[P]	[X] *
IOA	[2 /1R]	[P]	[P]	[P]	[X]
COMPARE	[/]	[]	[N]	[]	[]

RECOMMENDATIONS: (If different from NASA)

[/] [] [] [] []
 (ADD/DELETE)

* CIL RETENTION RATIONALE: (If applicable)

ADEQUATE []
 INADEQUATE []

REMARKS:

IOA CONCURS. FAILURE DOES NOT PASS REDUNDANCY SCREEN B.
 RECOMMEND CHANGE IOA REDUNDANCY SCREEN B TO "F".
 RECOMMEND COMBINING IOA FMEAs TO AGREE WITH NASA FMEA.

APPENDIX C
ASSESSMENT WORKSHEET

ASSESSMENT DATE: 7/17/87
 ASSESSMENT ID: RMS-4547
 NASA FMEA #: 05-6ID-2511-1

NASA DATA:
 BASELINE [X]
 NEW []

SUBSYSTEM: RMS/EPD&C
 MDAC ID: 4547
 ITEM: PIC 19

LEAD ANALYST: ROBINSON

ASSESSMENT:

	CRITICALITY FLIGHT HDW/FUNC	REDUNDANCY SCREENS			CIL ITEM
		A	B	C	
NASA	[2 /1R]	[P]	[NA]	[P]	[X] *
IOA	[2 /1R]	[P]	[P]	[P]	[X]
COMPARE	[/]	[]	[N]	[]	[]

RECOMMENDATIONS: (If different from NASA)

[/] [] [] [] []
 (ADD/DELETE)

* CIL RETENTION RATIONALE: (If applicable)

ADEQUATE []
 INADEQUATE []

REMARKS:

FAILURE DOES NOT PASS REDUNDANCY SCREEN B. RECOMMEND CHANGE IOA AND NASA BASELINE REDUNDANCY SCREEN B TO "F".
 RECOMMEND COMBINING IOA FMEAs TO AGREE WITH NASA FMEA.

APPENDIX C
ASSESSMENT WORKSHEET

ASSESSMENT DATE: 2/15/88
 ASSESSMENT ID: RMS-4548
 NASA FMEA #: 05-6ID-2503-2

NASA DATA:
 BASELINE [X]
 NEW []

SUBSYSTEM: RMS/EPD&C
 MDAC ID: 4548
 ITEM: PIC 8, 19

LEAD ANALYST: ROBINSON

ASSESSMENT:

	CRITICALITY FLIGHT HDW/FUNC	REDUNDANCY SCREENS			CIL ITEM
		A	B	C	
NASA	[3 /1R]	[P]	[P]	[P]	[] *
IOA	[2 /1R]	[P]	[P]	[P]	[X]
COMPARE	[N /]	[]	[]	[]	[N]

RECOMMENDATIONS: (If different from NASA)

[/] [] [] [P] []
 (ADD/DELETE)

* CIL RETENTION RATIONALE: (If applicable)

ADEQUATE []
 INADEQUATE []

REMARKS:

NO ISSUE. AFTER FURTHER ANALYSIS IOA RECOMMENDS DOWNGRADING THE IOA CRIT TO 3/1R AND DELETING THIS FMEA FROM THE IOA CIL LIST. NOMINALLY FOR A PIC TO ARM AND FIRE PREMATURELY, AN "ARM", "FIRE 1", AND A "FIRE 2" ARE REQUIRED. IOA RECOMMENDS COMBINING THE COMPONENTS OF IOA FMEAs 4548 AND 4549.

APPENDIX C
ASSESSMENT WORKSHEET

ASSESSMENT DATE: 2/15/88
 ASSESSMENT ID: RMS-4549
 NASA FMEA #: 05-6ID-2511-2

NASA DATA:
 BASELINE [X]
 NEW []

SUBSYSTEM: RMS/EPD&C
 MDAC ID: 4549
 ITEM: PIC 8, 19

LEAD ANALYST: ROBINSON

ASSESSMENT:

	CRITICALITY FLIGHT HDW/FUNC	REDUNDANCY SCREENS			CIL ITEM
		A	B	C	
NASA	[3 /1R]	[P]	[P]	[P]	[] *
IOA	[2 /1R]	[P]	[P]	[P]	[X]
COMPARE	[N /]	[]	[]	[]	[N]

RECOMMENDATIONS: (If different from NASA)

[/] [] [] [P] []
 (ADD/DELETE)

* CIL RETENTION RATIONALE: (If applicable)

ADEQUATE []
 INADEQUATE []

REMARKS:

NO ISSUE. AFTER FURTHER ANALYSIS IOA RECOMMENDS DOWNGRADING THE IOA CRIT TO 3/1R AND DELETING THIS FMEA FROM THE IOA CIL LIST. NOMINALLY FOR A PIC TO ARM AND FIRE PREMATURELY, AN "ARM", "FIRE 1", AND A "FIRE 2" ARE REQUIRED. IOA RECOMMENDS COMBINING THE COMPONENTS OF IOA FMEAS 4548 AND 4549.

APPENDIX C
ASSESSMENT WORKSHEET

ASSESSMENT DATE: 1/12/88
 ASSESSMENT ID: RMS-4550
 NASA FMEA #: 05-6ID-2501-1

NASA DATA:
 BASELINE []
 NEW [X]

SUBSYSTEM: RMS/EPD&C
 MDAC ID: 4550
 ITEM: PIC 10

LEAD ANALYST: ROBINSON

ASSESSMENT:

	CRITICALITY FLIGHT HDW/FUNC	REDUNDANCY SCREENS			CIL ITEM
		A	B	C	
NASA	[2 /1R]	[P]	[F]	[P]	[X] *
IOA	[2 /1R]	[P]	[P]	[P]	[X]
COMPARE	[/]	[]	[N]	[]	[]

RECOMMENDATIONS: (If different from NASA)

[/] [] [] [] []
 (ADD/DELETE)

* CIL RETENTION RATIONALE: (If applicable)

ADEQUATE []
 INADEQUATE []

REMARKS:
 IOA CONCURS. FAILURE DOES NOT PASS REDUNDANCY SCREEN B.
 RECOMMEND CHANGE IOA REDUNDANCY SCREEN B TO "F".
 RECOMMEND COMBINING IOA FMEAs TO AGREE WITH NASA FMEA.

APPENDIX C
ASSESSMENT WORKSHEET

ASSESSMENT DATE: 7/17/87
 ASSESSMENT ID: RMS-4551
 NASA FMEA #: 05-6ID-2509-1

NASA DATA:
 BASELINE [X]
 NEW []

SUBSYSTEM: RMS/EPD&C
 MDAC ID: 4551
 ITEM: PIC 10

LEAD ANALYST: ROBINSON

ASSESSMENT:

	CRITICALITY FLIGHT HDW/FUNC	REDUNDANCY SCREENS			CIL ITEM
		A	B	C	
NASA	[2 /1R]	[P]	[P]	[P]	[X] *
IOA	[2 /1R]	[P]	[P]	[P]	[X]
COMPARE	[/]	[]	[]	[]	[]

RECOMMENDATIONS: (If different from NASA)

[/] [] [] [] []
 (ADD/DELETE)

* CIL RETENTION RATIONALE: (If applicable)

ADEQUATE []
 INADEQUATE []

REMARKS:

FAILURE DOES NOT PASS REDUNDANCY SCREEN B. RECOMMEND CHANGE IOA AND NASA BASELINE REDUNDANCY SCREEN B TO "F".
 RECOMMEND COMBINING IOA FMEAs TO AGREE WITH NASA FMEA.

C-5

APPENDIX C
ASSESSMENT WORKSHEET

ASSESSMENT DATE: 1/12/88
 ASSESSMENT ID: RMS-4552
 NASA FMEA #: 05-6ID-2501-1

NASA DATA:
 BASELINE []
 NEW [X]

SUBSYSTEM: RMS/EPD&C
 MDAC ID: 4552
 ITEM: PIC 21

LEAD ANALYST: ROBINSON

ASSESSMENT:

	CRITICALITY FLIGHT HDW/FUNC	REDUNDANCY SCREENS			CIL ITEM
		A	B	C	
NASA	[2 /1R]	[P]	[F]	[P]	[X] *
IOA	[2 /1R]	[P]	[P]	[P]	[X]
COMPARE	[/]	[]	[N]	[]	[]

RECOMMENDATIONS: (If different from NASA)

[/] [] [] [] []
 (ADD/DELETE)

* CIL RETENTION RATIONALE: (If applicable)

ADEQUATE []
 INADEQUATE []

REMARKS:

IOA CONCURS. FAILURE DOES NOT PASS REDUNDANCY SCREEN B.
 RECOMMEND CHANGE IOA REDUNDANCY SCREEN B TO "F".
 RECOMMEND COMBINING IOA FMEAs TO AGREE WITH NASA FMEA.

APPENDIX C
ASSESSMENT WORKSHEET

ASSESSMENT DATE: 7/17/87
 ASSESSMENT ID: RMS-4553
 NASA FMEA #: 05-6ID-2509-1

NASA DATA:
 BASELINE [X]
 NEW []

SUBSYSTEM: RMS/EPD&C
 MDAC ID: 4553
 ITEM: PIC 21

LEAD ANALYST: ROBINSON

ASSESSMENT:

	CRITICALITY FLIGHT HDW/FUNC	REDUNDANCY SCREENS			CIL ITEM
		A	B	C	
NASA	[2 /1R]	[P]	[NA]	[P]	[X] *
IOA	[2 /1R]	[P]	[P]	[P]	[X]
COMPARE	[/]	[]	[N]	[]	[]

RECOMMENDATIONS: (If different from NASA)

[/] [] [] [] []
 (ADD/DELETE)

* CIL RETENTION RATIONALE: (If applicable)

ADEQUATE []
 INADEQUATE []

REMARKS:

FAILURE DOES NOT PASS REDUNDANCY SCREEN B. RECOMMEND CHANGE IOA AND NASA BASELINE REDUNDANCY SCREEN B TO "F".
 RECOMMEND COMBINING IOA FMEAS TO AGREE WITH NASA FMEA.

APPENDIX C
ASSESSMENT WORKSHEET

ASSESSMENT DATE: 2/15/88
 ASSESSMENT ID: RMS-4554
 NASA FMEA #: 05-6ID-2501-2

NASA DATA:
 BASELINE [X]
 NEW []

SUBSYSTEM: RMS/EPD&C
 MDAC ID: 4554
 ITEM: PIC 10, 21

LEAD ANALYST: ROBINSON

ASSESSMENT:

	CRITICALITY FLIGHT HDW/FUNC	REDUNDANCY SCREENS			CIL ITEM
		A	B	C	
NASA	[3 /1R]	[P]	[P]	[P]	[] *
IOA	[2 /1R]	[P]	[P]	[P]	[X]
COMPARE	[N /]	[]	[]	[]	[N]

RECOMMENDATIONS: (If different from NASA)

[/] [] [] [] []
 (ADD/DELETE)

* CIL RETENTION RATIONALE: (If applicable)

ADEQUATE []
 INADEQUATE []

REMARKS:

NO ISSUE. AFTER FURTHER ANALYSIS IOA RECOMMENDS DOWNGRADING THE IOA CRIT TO 3/1R AND DELETING THIS FMEA FROM THE IOA CIL LIST. NOMINALLY FOR A PIC TO ARM AND FIRE PREMATURELY, AN "ARM", "FIRE 1", AND A "FIRE 2" ARE REQUIRED. IOA RECOMMENDS COMBINING THE COMPONENTS OF IOA FMEAs 4554 AND 4555.

APPENDIX C
ASSESSMENT WORKSHEET

ASSESSMENT DATE: 2/15/88
 ASSESSMENT ID: RMS-4555
 NASA FMEA #: 05-6ID-2509-2

NASA DATA:
 BASELINE [X]
 NEW []

SUBSYSTEM: RMS/EPD&C
 MDAC ID: 4555
 ITEM: PIC 10, 21

LEAD ANALYST: ROBINSON

ASSESSMENT:

	CRITICALITY FLIGHT HDW/FUNC	REDUNDANCY SCREENS			CIL ITEM
		A	B	C	
NASA	[3 /1R]	[P]	[P]	[P]	[] *
IOA	[2 /1R]	[P]	[P]	[P]	[X]
COMPARE	[N /]	[]	[]	[]	[N]

RECOMMENDATIONS: (If different from NASA)

[/] [] [] [P] []
 (ADD/DELETE)

* CIL RETENTION RATIONALE: (If applicable)

ADEQUATE []
 INADEQUATE []

REMARKS:

NO ISSUE. AFTER FURTHER ANALYSIS IOA RECOMMENDS DOWNGRADING THE IOA CRIT TO 3/1R AND DELETING THIS FMEA FROM THE IOA CIL LIST. NOMINALLY FOR A PIC TO ARM AND FIRE PREMATURELY, AN "ARM", "FIRE 1", AND A "FIRE 2" ARE REQUIRED. IOA RECOMMENDS COMBINING THE COMPONENTS OF IOA FMEAs 4554 AND 4555.

APPENDIX C
ASSESSMENT WORKSHEET

ASSESSMENT DATE: 1/12/88
 ASSESSMENT ID: RMS-4556
 NASA FMEA #: 05-6ID-2506-1

NASA DATA:
 BASELINE []
 NEW [X]

SUBSYSTEM: RMS/EPD&C
 MDAC ID: 4556
 ITEM: PIC 2

LEAD ANALYST: ROBINSON

ASSESSMENT:

	CRITICALITY FLIGHT HDW/FUNC	REDUNDANCY SCREENS			CIL ITEM
		A	B	C	
NASA	[2 /1R]	[P]	[F]	[P]	[X] *
IOA	[2 /1R]	[P]	[P]	[P]	[X]
COMPARE	[/]	[]	[N]	[]	[]

RECOMMENDATIONS: (If different from NASA)

[/] [] [] [] []
 (ADD/DELETE)

* CIL RETENTION RATIONALE: (If applicable)

ADEQUATE []
 INADEQUATE []

REMARKS:

IOA CONCURS. FAILURE DOES NOT PASS REDUNDANCY SCREEN B.
 RECOMMEND CHANGE IOA REDUNDANCY SCREEN B TO "F".
 RECOMMEND COMBINING IOA FMEAs TO AGREE WITH NASA FMEA.

APPENDIX C
ASSESSMENT WORKSHEET

ASSESSMENT DATE: 7/17/87
 ASSESSMENT ID: RMS-4557
 NASA FMEA #: 05-6ID-2514-1

NASA DATA:
 BASELINE [X]
 NEW []

SUBSYSTEM: RMS/EPD&C
 MDAC ID: 4557
 ITEM: PIC 2

LEAD ANALYST: ROBINSON

ASSESSMENT:

	CRITICALITY FLIGHT HDW/FUNC	REDUNDANCY SCREENS			CIL ITEM
		A	B	C	
NASA	[2 /1R]	[P]	[NA]	[P]	[X] *
IOA	[2 /1R]	[P]	[P]	[P]	[X]
COMPARE	[/]	[]	[N]	[]	[]

RECOMMENDATIONS: (If different from NASA)

[/] [] [] [] []
 (ADD/DELETE)

* CIL RETENTION RATIONALE: (If applicable)

ADEQUATE []
 INADEQUATE []

REMARKS:

FAILURE DOES NOT PASS REDUNDANCY SCREEN B. RECOMMEND CHANGE IOA AND NASA BASELINE REDUNDANCY SCREEN B TO "F".
 RECOMMEND COMBINING IOA FMEAs TO AGREE WITH NASA FMEA.

APPENDIX C
ASSESSMENT WORKSHEET

ASSESSMENT DATE: 1/12/88
 ASSESSMENT ID: RMS-4558
 NASA FMEA #: 05-6ID-2506-1

NASA DATA:
 BASELINE []
 NEW [X]

SUBSYSTEM: RMS/EPD&C
 MDAC ID: 4558
 ITEM: PIC 13

LEAD ANALYST: ROBINSON

ASSESSMENT:

	CRITICALITY FLIGHT HDW/FUNC	REDUNDANCY SCREENS			CIL ITEM
		A	B	C	
NASA	[2 /1R]	[P]	[F]	[P]	[X] *
IOA	[2 /1R]	[P]	[P]	[P]	[X]
COMPARE	[/]	[]	[N]	[]	[]

RECOMMENDATIONS: (If different from NASA)

[/] [] [] [] [] (ADD/DELETE)

* CIL RETENTION RATIONALE: (If applicable)

ADEQUATE []
 INADEQUATE []

REMARKS:

IOA CONCURS. FAILURE DOES NOT PASS REDUNDANCY SCREEN B.
 RECOMMEND CHANGE IOA REDUNDANCY SCREEN B TO "F".
 RECOMMEND COMBINING IOA FMEAs TO AGREE WITH NASA FMEA.

APPENDIX C
ASSESSMENT WORKSHEET

ASSESSMENT DATE: 7/17/87
 ASSESSMENT ID: RMS-4559
 NASA FMEA #: 05-6ID-2514-1

NASA DATA:
 BASELINE [X]
 NEW []

SUBSYSTEM: RMS/EPD&C
 MDAC ID: 4559
 ITEM: PIC 13

LEAD ANALYST: ROBINSON

ASSESSMENT:

	CRITICALITY FLIGHT HDW/FUNC	REDUNDANCY SCREENS			CIL ITEM
		A	B	C	
NASA	[2 /1R]	[P]	[NA]	[P]	[X] *
IOA	[2 /1R]	[P]	[P]	[P]	[X]
COMPARE	[/]	[]	[N]	[]	[]

RECOMMENDATIONS: (If different from NASA)

[/] [] [] [] []
 (ADD/DELETE)

* CIL RETENTION RATIONALE: (If applicable)

ADEQUATE []
 INADEQUATE []

REMARKS:

FAILURE DOES NOT PASS REDUNDANCY SCREEN B. RECOMMEND CHANGE IOA AND NASA BASELINE REDUNDANCY SCREEN B TO "F".
 RECOMMEND COMBINING IOA FMEAs TO AGREE WITH NASA FMEA.

APPENDIX C
ASSESSMENT WORKSHEET

ASSESSMENT DATE: 2/15/88
 ASSESSMENT ID: RMS-4560
 NASA FMEA #: 05-6ID-2506-2

NASA DATA:
 BASELINE [X]
 NEW []

SUBSYSTEM: RMS/EPD&C
 MDAC ID: 4560
 ITEM: PIC 2, 13

LEAD ANALYST: ROBINSON

ASSESSMENT:

	CRITICALITY FLIGHT HDW/FUNC	REDUNDANCY SCREENS			CIL ITEM
		A	B	C	
NASA	[3 /1R]	[P]	[P]	[P]	[] *
IOA	[2 /1R]	[P]	[P]	[P]	[X]
COMPARE	[N /]	[]	[]	[]	[N]

RECOMMENDATIONS: (If different from NASA)

[/] [] [] [P] []
 (ADD/DELETE)

* CIL RETENTION RATIONALE: (If applicable)

ADEQUATE []
 INADEQUATE []

REMARKS:

NO ISSUE. AFTER FURTHER ANALYSIS IOA RECOMMENDS DOWNGRADING THE IOA CRIT TO 3/1R AND DELETING THIS FMEA FROM THE IOA CIL LIST. NOMINALLY FOR A PIC TO ARM AND FIRE PREMATURELY, AN "ARM", "FIRE 1", AND A "FIRE 2" ARE REQUIRED. IOA RECOMMENDS COMBINING THE COMPONENTS OF IOA FMEAs 4536 AND 4537.

APPENDIX C
ASSESSMENT WORKSHEET

ASSESSMENT DATE: 2/15/88
 ASSESSMENT ID: RMS-4561
 NASA FMEA #: 05-6ID-2514-2

NASA DATA:
 BASELINE [X]
 NEW []

SUBSYSTEM: RMS/EPD&C
 MDAC ID: 4561
 ITEM: PIC 2, 13

LEAD ANALYST: ROBINSON

ASSESSMENT:

	CRITICALITY FLIGHT HDW/FUNC	REDUNDANCY SCREENS			CIL ITEM
		A	B	C	
NASA	[3 /1R]	[P]	[P]	[P]	[] *
IOA	[2 /1R]	[P]	[P]	[P]	[X]
COMPARE	[N /]	[]	[]	[]	[N]

RECOMMENDATIONS: (If different from NASA)

[/] [] [] [P] []
 (ADD/DELETE)

* CIL RETENTION RATIONALE: (If applicable)

ADEQUATE []
 INADEQUATE []

REMARKS:

NO ISSUE. AFTER FURTHER ANALYSIS IOA RECOMMENDS DOWNGRADING THE IOA CRIT TO 3/1R AND DELETING THIS FMEA FROM THE IOA CIL LIST. NOMINALLY FOR A PIC TO ARM AND FIRE PREMATURELY, AN "ARM", "FIRE 1", AND A "FIRE 2" ARE REQUIRED. IOA RECOMMENDS COMBINING THE COMPONENTS OF IOA FMEAs 4560 AND 4561.

APPENDIX C
ASSESSMENT WORKSHEET

ASSESSMENT DATE: 1/12/88
 ASSESSMENT ID: RMS-4562
 NASA FMEA #: 05-6ID-2504-1

NASA DATA:
 BASELINE []
 NEW [X]

SUBSYSTEM: RMS/EPD&C
 MDAC ID: 4562
 ITEM: PIC 7

LEAD ANALYST: ROBINSON

ASSESSMENT:

	CRITICALITY FLIGHT HDW/FUNC	REDUNDANCY SCREENS			CIL ITEM
		A	B	C	
NASA	[2 /1R]	[P]	[F]	[P]	[X] *
IOA	[2 /1R]	[P]	[P]	[P]	[X]
COMPARE	[/]	[]	[N]	[]	[]

RECOMMENDATIONS: (If different from NASA)

[/] [] [] [] []
 (ADD/DELETE)

* CIL RETENTION RATIONALE: (If applicable)

ADEQUATE []
 INADEQUATE []

REMARKS:

IOA CONCURS. FAILURE DOES NOT PASS REDUNDANCY SCREEN B.
 RECOMMEND CHANGE IOA REDUNDANCY SCREEN B TO "F".
 RECOMMEND COMBINING IOA FMEAs TO AGREE WITH NASA FMEA.

APPENDIX C
ASSESSMENT WORKSHEET

ASSESSMENT DATE: 7/17/87
 ASSESSMENT ID: RMS-4563
 NASA FMEA #: 05-6ID-2512-1

NASA DATA:
 BASELINE [X]
 NEW []

SUBSYSTEM: RMS/EPD&C
 MDAC ID: 4563
 ITEM: PIC 7

LEAD ANALYST: ROBINSON

ASSESSMENT:

	CRITICALITY FLIGHT HDW/FUNC	REDUNDANCY SCREENS			CIL ITEM
		A	B	C	
NASA	[2 /1R]	[P]	[NA]	[P]	[X] *
IOA	[2 /1R]	[P]	[P]	[P]	[X]
COMPARE	[/]	[]	[N]	[]	[]

RECOMMENDATIONS: (If different from NASA)

[/] [] [] [] []
 (ADD/DELETE)

* CIL RETENTION RATIONALE: (If applicable)

ADEQUATE []
 INADEQUATE []

REMARKS:

FAILURE DOES NOT PASS REDUNDANCY SCREEN B. RECOMMEND CHANGE IOA AND NASA BASELINE REDUNDANCY SCREEN B TO "F".
 RECOMMEND COMBINING IOA FMEAs TO AGREE WITH NASA FMEA.

APPENDIX C
ASSESSMENT WORKSHEET

ASSESSMENT DATE: 1/12/88
 ASSESSMENT ID: RMS-4564
 NASA FMEA #: 05-6ID-2504-1

NASA DATA:
 BASELINE []
 NEW [X]

SUBSYSTEM: RMS/EPD&C
 MDAC ID: 4564
 ITEM: PIC 18

LEAD ANALYST: ROBINSON

ASSESSMENT:

	CRITICALITY FLIGHT HDW/FUNC	REDUNDANCY SCREENS			CIL ITEM
		A	B	C	
NASA	[2 /1R]	[P]	[F]	[P]	[X] *
IOA	[2 /1R]	[P]	[P]	[P]	[X]
COMPARE	[/]	[]	[N]	[]	[]

RECOMMENDATIONS: (If different from NASA)

[/] [] [] [] []
 (ADD/DELETE)

* CIL RETENTION RATIONALE: (If applicable)

ADEQUATE []
 INADEQUATE []

REMARKS:

IOA CONCURS. FAILURE DOES NOT PASS REDUNDANCY SCREEN B.
 RECOMMEND CHANGE IOA REDUNDANCY SCREEN B TO "F".
 RECOMMEND COMBINING IOA FMEAs TO AGREE WITH NASA FMEA.

APPENDIX C
ASSESSMENT WORKSHEET

ASSESSMENT DATE: 7/17/87
 ASSESSMENT ID: RMS-4565
 NASA FMEA #: 05-6ID-2512-1

NASA DATA:
 BASELINE [X]
 NEW []

SUBSYSTEM: RMS/EPD&C
 MDAC ID: 4565
 ITEM: PIC 18

LEAD ANALYST: ROBINSON

ASSESSMENT:

	CRITICALITY FLIGHT HDW/FUNC	REDUNDANCY SCREENS			CIL ITEM
		A	B	C	
NASA	[2 /1R]	[P]	[NA]	[P]	[X] *
IOA	[2 /1R]	[P]	[P]	[P]	[X]
COMPARE	[/]	[]	[N]	[]	[]

RECOMMENDATIONS: (If different from NASA)

[/] [] [] [] []
 (ADD/DELETE)

* CIL RETENTION RATIONALE: (If applicable)

ADEQUATE []
 INADEQUATE []

REMARKS:

FAILURE DOES NOT PASS REDUNDANCY SCREEN B. RECOMMEND CHANGE IOA AND NASA BASELINE REDUNDANCY SCREEN B TO "F".
 RECOMMEND COMBINING IOA FMEAS TO AGREE WITH NASA FMEA.

APPENDIX C
ASSESSMENT WORKSHEET

ASSESSMENT DATE: 2/15/88
 ASSESSMENT ID: RMS-4566
 NASA FMEA #: 05-6ID-2504-2

NASA DATA:
 BASELINE [X]
 NEW []

SUBSYSTEM: RMS/EPD&C
 MDAC ID: 4566
 ITEM: PIC 7, 18

LEAD ANALYST: ROBINSON

ASSESSMENT:

	CRITICALITY FLIGHT HDW/FUNC	REDUNDANCY SCREENS			CIL ITEM
		A	B	C	
NASA	[3 /1R]	[P]	[P]	[P]	[] *
IOA	[2 /1R]	[P]	[P]	[P]	[X]
COMPARE	[N /]	[]	[]	[]	[N]

RECOMMENDATIONS: (If different from NASA)

[/] [] [] [P] []
 (ADD/DELETE)

* CIL RETENTION RATIONALE: (If applicable)

ADEQUATE []
 INADEQUATE []

REMARKS:

NO ISSUE. AFTER FURTHER ANALYSIS IOA RECOMMENDS DOWNGRADING THE IOA CRIT TO 3/1R AND DELETING THIS FMEA FROM THE IOA CIL LIST. NOMINALLY FOR A PIC TO ARM AND FIRE PREMATURELY, AN "ARM", "FIRE 1", AND A "FIRE 2" ARE REQUIRED. IOA RECOMMENDS COMBINING THE COMPONENTS OF IOA FMEAS 4566 AND 4567.

APPENDIX C
ASSESSMENT WORKSHEET

ASSESSMENT DATE: 2/15/88
 ASSESSMENT ID: RMS-4567
 NASA FMEA #: 05-6ID-2512-2

NASA DATA:
 BASELINE [X]
 NEW []

SUBSYSTEM: RMS/EPD&C
 MDAC ID: 4567
 ITEM: PIC 7, 18

LEAD ANALYST: ROBINSON

ASSESSMENT:

	CRITICALITY FLIGHT HDW/FUNC	REDUNDANCY SCREENS			CIL ITEM
		A	B	C	
NASA	[3 /1R]	[P]	[P]	[P]	[] *
IOA	[2 /1R]	[P]	[P]	[P]	[X]
COMPARE	[N /]	[]	[]	[]	[N]

RECOMMENDATIONS: (If different from NASA)

[/] [] [] [P] []
 (ADD/DELETE)

* CIL RETENTION RATIONALE: (If applicable)

ADEQUATE []
 INADEQUATE []

REMARKS:

NO ISSUE. AFTER FURTHER ANALYSIS IOA RECOMMENDS DOWNGRADING THE IOA CRIT TO 3/1R AND DELETING THIS FMEA FROM THE IOA CIL LIST. NOMINALLY FOR A PIC TO ARM AND FIRE PREMATURELY, AN "ARM", "FIRE 1", AND A "FIRE 2" ARE REQUIRED. IOA RECOMMENDS COMBINING THE COMPONENTS OF IOA FMEAs 4566 AND 4567.

APPENDIX C
ASSESSMENT WORKSHEET

ASSESSMENT DATE: 7/17/87
 ASSESSMENT ID: RMS-4568
 NASA FMEA #: 05-6ID-2502-1

NASA DATA:
 BASELINE []
 NEW [X]

SUBSYSTEM: RMS/EPD&C
 MDAC ID: 4568
 ITEM: PIC 9

LEAD ANALYST: ROBINSON

ASSESSMENT:

	CRITICALITY FLIGHT HDW/FUNC	REDUNDANCY SCREENS			CIL ITEM
		A	B	C	
NASA	[2 /1R]	[P]	[F]	[P]	[X] *
IOA	[2 /1R]	[P]	[P]	[P]	[X]
COMPARE	[/]	[]	[N]	[]	[]

RECOMMENDATIONS: (If different from NASA)

[/] [] [] [] [] (ADD/DELETE)

* CIL RETENTION RATIONALE: (If applicable)

ADEQUATE []
 INADEQUATE []

REMARKS:

IOA CONCURS. FAILURE DOES NOT PASS REDUNDANCY SCREEN B.
 RECOMMEND CHANGE IOA REDUNDANCY SCREEN B TO "F".
 RECOMMEND COMBINING IOA FMEAS TO AGREE WITH NASA FMEA.

APPENDIX C
ASSESSMENT WORKSHEET

ASSESSMENT DATE: 7/17/87
 ASSESSMENT ID: RMS-4569
 NASA FMEA #: 05-6ID-2510-1

NASA DATA:
 BASELINE [X]
 NEW []

SUBSYSTEM: RMS/EPD&C
 MDAC ID: 4569
 ITEM: PIC 9

LEAD ANALYST: ROBINSON

ASSESSMENT:

	CRITICALITY FLIGHT HDW/FUNC	REDUNDANCY SCREENS			CIL ITEM
		A	B	C	
NASA	[2 /1R]	[P]	[NA]	[P]	[X] *
IOA	[2 /1R]	[P]	[P]	[P]	[X]
COMPARE	[/]	[]	[N]	[]	[]

RECOMMENDATIONS: (If different from NASA)

[/] [] [] [] []
 (ADD/DELETE)

* CIL RETENTION RATIONALE: (If applicable)

ADEQUATE []
 INADEQUATE []

REMARKS:

FAILURE DOES NOT PASS REDUNDANCY SCREEN B. RECOMMEND CHANGE IOA
 AND NASA BASELINE REDUNDANCY SCREEN B TO "F".
 RECOMMEND COMBINING IOA FMEAS TO AGREE WITH NASA FMEA.

APPENDIX C
ASSESSMENT WORKSHEET

ASSESSMENT DATE: 1/12/88
 ASSESSMENT ID: RMS-4570
 NASA FMEA #: 05-6ID-2502-1

NASA DATA:
 BASELINE []
 NEW [X]

SUBSYSTEM: RMS/EPD&C
 MDAC ID: 4570
 ITEM: PIC 20

LEAD ANALYST: ROBINSON

ASSESSMENT:

	CRITICALITY FLIGHT HDW/FUNC	REDUNDANCY SCREENS			CIL ITEM
		A	B	C	
NASA	[2 /1R]	[P]	[F]	[P]	[X] *
IOA	[2 /1R]	[P]	[P]	[P]	[X]
COMPARE	[/]	[]	[N]	[]	[]

RECOMMENDATIONS: (If different from NASA)

[/] [] [] [] [] (ADD/DELETE)

* CIL RETENTION RATIONALE: (If applicable)

ADEQUATE []
 INADEQUATE []

REMARKS:

IOA CONCURS. FAILURE DOES NOT PASS REDUNDANCY SCREEN B.
 RECOMMEND CHANGE IOA REDUNDANCY SCREEN B TO "F".
 RECOMMEND COMBINING IOA FMEAs TO AGREE WITH NASA FMEA.

APPENDIX C
ASSESSMENT WORKSHEET

ASSESSMENT DATE: 7/17/87
 ASSESSMENT ID: RMS-4571
 NASA FMEA #: 05-6ID-2510-1

NASA DATA:
 BASELINE [X]
 NEW []

SUBSYSTEM: RMS/EPD&C
 MDAC ID: 4571
 ITEM: PIC 20

LEAD ANALYST: ROBINSON

ASSESSMENT:

	CRITICALITY FLIGHT HDW/FUNC	REDUNDANCY SCREENS			CIL ITEM
		A	B	C	
NASA	[2 /1R]	[P]	[NA]	[P]	[X] *
IOA	[2 /1R]	[P]	[P]	[P]	[X]
COMPARE	[/]	[]	[N]	[]	[]

RECOMMENDATIONS: (If different from NASA)

[/] [] [] [] []
 (ADD/DELETE)

* CIL RETENTION RATIONALE: (If applicable)

ADEQUATE []
 INADEQUATE []

REMARKS:

FAILURE DOES NOT PASS REDUNDANCY SCREEN B. RECOMMEND CHANGE IOA AND NASA BASELINE REDUNDANCY SCREEN B TO "F".
 RECOMMEND COMBINING IOA FMEAs TO AGREE WITH NASA FMEA.

APPENDIX C
ASSESSMENT WORKSHEET

ASSESSMENT DATE: 2/15/88
 ASSESSMENT ID: RMS-4572
 NASA FMEA #: 05-6ID-2502-2

NASA DATA:
 BASELINE [X]
 NEW []

SUBSYSTEM: RMS/EPD&C
 MDAC ID: 4572
 ITEM: PIC 9, 20

LEAD ANALYST: ROBINSON

ASSESSMENT:

	CRITICALITY FLIGHT HDW/FUNC	REDUNDANCY SCREENS			CIL ITEM
		A	B	C	
NASA	[3 /1R]	[P]	[NA]	[P]	[] *
IOA	[2 /1R]	[P]	[P]	[P]	[X]
COMPARE	[N /]	[]	[N]	[]	[N]

RECOMMENDATIONS: (If different from NASA)

[/] [] [] [P] []
 (ADD/DELETE)

* CIL RETENTION RATIONALE: (If applicable)

ADEQUATE []
 INADEQUATE []

REMARKS:

NO ISSUE. AFTER FURTHER ANALYSIS IOA RECOMMENDS DOWNGRADING THE IOA CRIT TO 3/1R AND DELETING THIS FMEA FROM THE IOA CIL LIST. NOMINALLY FOR A PIC TO ARM AND FIRE PREMATURELY, AN "ARM", "FIRE 1", AND A "FIRE 2" ARE REQUIRED. IOA RECOMMENDS COMBINING THE COMPONENTS OF IOA FMEAS 4572 AND 4573.

APPENDIX C
ASSESSMENT WORKSHEET

ASSESSMENT DATE: 2/15/88
 ASSESSMENT ID: RMS-4573
 NASA FMEA #: 05-6ID-2510-2

NASA DATA:
 BASELINE [X]
 NEW []

SUBSYSTEM: RMS/EPD&C
 MDAC ID: 4573
 ITEM: PIC 9, 20

LEAD ANALYST: ROBINSON

ASSESSMENT:

	CRITICALITY FLIGHT HDW/FUNC	REDUNDANCY SCREENS			CIL ITEM
		A	B	C	
NASA	[3 /1R]	[P]	[P]	[P]	[] *
IOA	[2 /1R]	[P]	[P]	[P]	[X]
COMPARE	[N /]	[]	[]	[]	[N]

RECOMMENDATIONS: (If different from NASA)

[/] [] [] [P] []
 (ADD/DELETE)

* CIL RETENTION RATIONALE: (If applicable)

ADEQUATE []
 INADEQUATE []

REMARKS:

NO ISSUE. AFTER FURTHER ANALYSIS IOA RECOMMENDS DOWNGRADING THE IOA CRIT TO 3/1R AND DELETING THIS FMEA FROM THE IOA CIL LIST. NOMINALLY FOR A PIC TO ARM AND FIRE PREMATURELY, AN "ARM", "FIRE 1", AND A "FIRE 2" ARE REQUIRED. IOA RECOMMENDS COMBINING THE COMPONENTS OF IOA FMEAs 4572 AND 4573.

APPENDIX C
ASSESSMENT WORKSHEET

ASSESSMENT DATE: 1/12/88
 ASSESSMENT ID: RMS-4574
 NASA FMEA #: 05-6ID-2500-1

NASA DATA:
 BASELINE []
 NEW [X]

SUBSYSTEM: RMS/EPD&C
 MDAC ID: 4574
 ITEM: PIC 11

LEAD ANALYST: ROBINSON

ASSESSMENT:

	CRITICALITY FLIGHT HDW/FUNC	REDUNDANCY SCREENS			CIL ITEM
		A	B	C	
NASA	[2 /1R]	[P]	[F]	[P]	[X] *
IOA	[2 /1R]	[P]	[P]	[P]	[X]
COMPARE	[/]	[]	[N]	[]	[]

RECOMMENDATIONS: (If different from NASA)

[/] [] [] [] []
 (ADD/DELETE)

* CIL RETENTION RATIONALE: (If applicable)

ADEQUATE []
 INADEQUATE []

REMARKS:
 IOA CONCURS. FAILURE DOES NOT PASS REDUNDANCY SCREEN B.
 RECOMMEND CHANGE IOA REDUNDANCY SCREEN B TO "F".
 RECOMMEND COMBINING IOA FMEAs TO AGREE WITH NASA FMEA.

APPENDIX C
ASSESSMENT WORKSHEET

ASSESSMENT DATE: 7/17/87
 ASSESSMENT ID: RMS-4575
 NASA FMEA #: 05-6ID-2508-1

NASA DATA:
 BASELINE [X]
 NEW []

SUBSYSTEM: RMS/EPD&C
 MDAC ID: 4575
 ITEM: PIC 11

LEAD ANALYST: ROBINSON

ASSESSMENT:

	CRITICALITY FLIGHT HDW/FUNC	REDUNDANCY SCREENS			CIL ITEM
		A	B	C	
NASA	[2 /1R]	[P]	[NA]	[P]	[X] *
IOA	[2 /1R]	[P]	[P]	[P]	[X]
COMPARE	[/]	[]	[N]	[]	[]

RECOMMENDATIONS: (If different from NASA)

[/] [] [] [] []
 (ADD/DELETE)

* CIL RETENTION RATIONALE: (If applicable)

ADEQUATE []
 INADEQUATE []

REMARKS:

FAILURE DOES NOT PASS REDUNDANCY SCREEN B. RECOMMEND CHANGE IOA AND NASA BASELINE REDUNDANCY SCREEN B TO "F".
 RECOMMEND COMBINING IOA FMEAs TO AGREE WITH NASA FMEA.

APPENDIX C
ASSESSMENT WORKSHEET

ASSESSMENT DATE: 1/12/88
 ASSESSMENT ID: RMS-4576
 NASA FMEA #: 05-6ID-2500-1

NASA DATA:
 BASELINE []
 NEW [X]

SUBSYSTEM: RMS/EPD&C
 MDAC ID: 4576
 ITEM: PIC 22

LEAD ANALYST: ROBINSON

ASSESSMENT:

	CRITICALITY FLIGHT HDW/FUNC	REDUNDANCY SCREENS			CIL ITEM
		A	B	C	
NASA	[2 /1R]	[P]	[F]	[P]	[X] *
IOA	[2 /1R]	[P]	[P]	[P]	[X]
COMPARE	[/]	[]	[N]	[]	[]

RECOMMENDATIONS: (If different from NASA)

[/] [] [] [] []
 (ADD/DELETE)

* CIL RETENTION RATIONALE: (If applicable)

ADEQUATE []
 INADEQUATE []

REMARKS:

IOA CONCURS. FAILURE DOES NOT PASS REDUNDANCY SCREEN B.
 RECOMMEND CHANGE IOA REDUNDANCY SCREEN B TO "F".
 RECOMMEND COMBINING IOA FMEAs TO AGREE WITH NASA FMEA.

APPENDIX C
ASSESSMENT WORKSHEET

ASSESSMENT DATE: 7/17/87
 ASSESSMENT ID: RMS-4577
 NASA FMEA #: 05-6ID-2508-1

NASA DATA:
 BASELINE [X]
 NEW []

SUBSYSTEM: RMS/EPD&C
 MDAC ID: 4577
 ITEM: PIC 22

LEAD ANALYST: ROBINSON

ASSESSMENT:

	CRITICALITY FLIGHT HDW/FUNC	REDUNDANCY SCREENS			CIL ITEM
		A	B	C	
NASA	[2 /1R]	[P]	[NA]	[P]	[X] *
IOA	[2 /1R]	[P]	[P]	[P]	[X]
COMPARE	[/]	[]	[N]	[]	[]

RECOMMENDATIONS: (If different from NASA)

[/] [] [] [] []
 (ADD/DELETE)

* CIL RETENTION RATIONALE: (If applicable)

ADEQUATE []
 INADEQUATE []

REMARKS:

FAILURE DOES NOT PASS REDUNDANCY SCREEN B. RECOMMEND CHANGE IOA
 AND NASA BASELINE REDUNDANCY SCREEN B TO "F".
 RECOMMEND COMBINING IOA FMEAs TO AGREE WITH NASA FMEA.

APPENDIX C
ASSESSMENT WORKSHEET

ASSESSMENT DATE: 2/15/88
 ASSESSMENT ID: RMS-4578
 NASA FMEA #: 05-6ID-2500-2

NASA DATA:
 BASELINE [X]
 NEW []

SUBSYSTEM: RMS/EPD&C
 MDAC ID: 4578
 ITEM: PIC 11, 22

LEAD ANALYST: ROBINSON

ASSESSMENT:

	CRITICALITY FLIGHT HDW/FUNC	REDUNDANCY SCREENS			CIL ITEM
		A	B	C	
NASA	[3 /1R]	[P]	[P]	[P]	[] *
IOA	[2 /1R]	[P]	[P]	[P]	[X]
COMPARE	[N /]	[]	[]	[]	[N]

RECOMMENDATIONS: (If different from NASA)

[/] [] [] [] []
 (ADD/DELETE)

* CIL RETENTION RATIONALE: (If applicable)

ADEQUATE []
 INADEQUATE []

REMARKS:

NO ISSUE. AFTER FURTHER ANALYSIS IOA RECOMMENDS DOWNGRADING THE IOA CRIT TO 3/1R AND DELETING THIS FMEA FROM THE IOA CIL LIST. NOMINALLY FOR A PIC TO ARM AND FIRE PREMATURELY, AN "ARM", "FIRE 1", AND A "FIRE 2" ARE REQUIRED. IOA RECOMMENDS COMBINING THE COMPONENTS OF IOA FMEAs 4578 AND 4579.

APPENDIX C
ASSESSMENT WORKSHEET

ASSESSMENT DATE: 2/15/88
 ASSESSMENT ID: RMS-4579
 NASA FMEA #: 05-6ID-2508-2

NASA DATA:
 BASELINE [X]
 NEW []

SUBSYSTEM: RMS/EPD&C
 MDAC ID: 4579
 ITEM: PIC 11, 22

LEAD ANALYST: ROBINSON

ASSESSMENT:

	CRITICALITY FLIGHT HDW/FUNC	REDUNDANCY SCREENS			CIL ITEM
		A	B	C	
NASA	[3 /1R]	[P]	[P]	[P]	[] *
IOA	[2 /1R]	[P]	[P]	[P]	[X]
COMPARE	[N /]	[]	[]	[]	[N]

RECOMMENDATIONS: (If different from NASA)

[/] [] [] [P] []
 (ADD/DELETE)

* CIL RETENTION RATIONALE: (If applicable)

ADEQUATE []
 INADEQUATE []

REMARKS:

NO ISSUE. AFTER FURTHER ANALYSIS IOA RECOMMENDS DOWNGRADING THE IOA CRIT TO 3/1R AND DELETING THIS FMEA FROM THE IOA CIL LIST. NOMINALLY FOR A PIC TO ARM AND FIRE PREMATURELY, AN "ARM", "FIRE 1", AND A "FIRE 2" ARE REQUIRED. IOA RECOMMENDS COMBINING THE COMPONENTS OF IOA FMEAs 4578 AND 4579.

APPENDIX D

CRITICAL ITEMS

APPENDIX D EPD&C/RMS 05-61A

NASA FMEA	IOA ID	ITEM NAME	FAILURE MODE
05-61A-2028-1X	4001	SWITCH, S4	FAILS TO SWITCH FROM OFF.
05-61A-2028-5	4002	SWITCH, S4	SHORTS TO GND WHILE IN USE.
05-61A-2028-1X	4003	SWITCH, S4	FAILS TO SWITCH PRI PWR ON.
05-61A-2028-1X	4004	SWITCH, S4	FAILS TO SWITCH BACKUP ON.
05-61A-2028-2X	4005	SWITCH, S4	PRI PWR FAILS OPEN IN USE.
05-61A-2028-6	4006	SWITCH, S4	FAILS CLOSED IN PRIMARY POS.
05-61A-2029-5	4007	SWITCH, S1	FAILS TO SWITCH FROM OFF.
05-61A-2029-5	4008	SWITCH, S1	SHORTS TO GND WHILE IN USE.
05-61A-2029-5	4009	SWITCH, S1	FAILS OPEN WHILE ARM IN USE.
05-61A-2026-1	4010	SWITCH, S8	FAILS OFF WHILE ARM IN USE.
05-61A-2026-1	4011	SWITCH, S10	FAILS OFF WHILE ARM IN USE.
05-61A-2026-2	4012	S8, S10	FAILS TO SWITCH FROM OFF.
05-61A-2026-1	4013	SWITCH, S7	FAILS OFF WHILE ARM IN USE.
05-61A-2026-1	4014	SWITCH, S9	FAILS TO SWITCH OFF.
05-61A-2026-2	4015	S7, S9	FAILS TO SWITCH OFF.
05-61A-2003-1	4016	FUSE, F1	FAILS OPEN PRIOR TO DEPLOY.
05-61A-2003-1	4017	FUSE, F1	FAILS OPEN WHILE IN USE.
05-61A-2002-1	4018	FUSE, F2	FAILS OPEN PRIOR TO DEPLOY.
05-61A-2002-1	4019	FUSE, F2	FAILS OPEN WHILE IN USE.
05-61A-2076-1	4020	RES, A3R2	FAILS OPEN.
05-61A-2076-1	4021	RES, A3R3	FAILS OPEN.
05-61A-2076-1	4022	RES, A2R2	FAILS OPEN.
05-61A-2076-1	4023	RES, A2R3	FAILS OPEN.
05-61A-2006-1	4028	CB17	FAILS OPEN PRIOR TO DEPLOY.
05-61A-2006-1	4029	CB17	FAILS OPEN WHILE IN USE.
05-61A-2001-1	4031	CB19	FAILS OPEN PRIOR TO DEPLOY.
05-61A-2001-1	4032	CB19	FAILS OPEN WHILE IN USE.
05-61A-2126-1	4034	RELAY, K1	FAILS OPEN PRIOR TO DEPLOY.
05-61A-2126-1	4035	RELAY, K1	FAILS OPEN WHILE IN USE.
05-61A-2126-2	4036	RELAY, K1	FAILS CLSD, APPL UNTIMELY PWR.
05-61A-2126-1	4037	RELAY, K2	FAILS OPEN PRIOR TO DEPLOY.
05-61A-2126-1	4038	RELAY, K2	FAILS OPEN WHILE IN USE.
05-61A-2126-2	4039	RELAY, K2	FAILS CLSD, APPL UNTIMELY PWR.
05-61A-2004-1	4040	FUSE, F26	FAILS OPEN.
05-61A-2004-1	4041	FUSE, F27	FAILS OPEN.
05-61A-2176-1	4042	RPC 27	OPEN, FAILS TO CLOSE.
05-61A-2176-1	4043	RPC 26	OPEN, FAILS TO CLOSE.
05-61A-2178-1	4044	RPC 4	OPEN, FAILS TO CLOSE.
05-61A-2179-1	4045	RPC 31	OPEN, FAILS TO CLOSE.
05-61A-2179-1	4046	RPC 30	OPEN, FAILS TO CLOSE.
05-61A-2176-1	4047	RPC 28	OPEN, FAILS TO CLOSE.
05-61A-2176-1	4048	RPC 29	OPEN, FAILS TO CLOSE.
05-61A-2028-9	4049	SWITCH, S4	POLE-POLE, CONT-CONT SHRT
05-61A-2176-2	4053	RPC 26,	OPEN, FAILS TO CLOSE.
05-61A-2179-2	4054	RPC 30,	OPEN, FAILS TO CLOSE.

APPENDIX D: EPD&C/RMS 05-61B

NASA FMEA	IOA ID	ITEM NAME	FAILURE MODE
05-6-2658-1	4101	SWITCH, S1	OPEN, FAILS TO CLOSE.
05-6-2658-1	4103	SWITCH, S2	OPEN, FAILS TO CLOSE.
05-61B-MPM-2A	4105	SWITCH, S5	OPEN, FAILS TO CLOSE DEPL/STOW.
05-61B-MPM-2B	4106	SWITCH, S5	FAILS CLOSED, APPL UNTIMELY PWR.
05-61B-MPM-2A	4107	SWITCH, S2	OPEN, FAILS TO CLOSE DEPL/STOW.
05-61B-MPM-2B	4108	SWITCH, S2	FAILS CLOSED, APPL UNTIMELY PWR.
05-61B-MPM-2B/D	4108	SWITCH, S2	FAILS CLOSED, APPL UNTIMELY PWR.
05-61B-MPM-2D	4108	SWITCH, S2	FAILS CLOSED, APPL UNTIMELY PWR.
05-61B-MPM-2E	4108	SWITCH, S2	FAILS CLOSED, APPL UNTIMELY PWR.
05-61B-MPM-2G	4108	SWITCH, S2	FAILS CLOSED, APPL UNTIMELY PWR.
05-61B-MPM-5	4114	HYB REL, K72	FAILS CLOSED, APPL UNTIMELY PWR.
05-61B-MPM-5	4116	HYB REL, K49	FAILS CLOSED, APPL UNTIMELY PWR.
05-61B-MPM-5	4118	HYB REL, K60	FAILS CLOSED, APPL UNTIMELY PWR.
05-61B-MPM-5	4120	HYB REL, K51	FAILS CLOSED, APPL UNTIMELY PWR.
05-61B-MPM-5	4122	HYB REL, K22	FAILS CLOSED, APPL UNTIMELY PWR.
05-61B-MPM-5	4124	HYB REL, K62	FAILS CLOSED, APPL UNTIMELY PWR.
05-61B-MPM-5	4126	HYB REL, K24	FAILS CLOSED, APPL UNTIMELY PWR.
05-61B-MPM-5	4128	HYB REL, K50	FAILS CLOSED, APPL UNTIMELY PWR.
05-61B-MPM-2F	4176X	SWITCH, S2	SHORTS TO GROUND

APPENDIX D: EPD&C/RMS 05-61C

NASA FMEA	IOA ID	ITEM NAME	FAILURE MODE
05-61C-MRL-6	4206	HYB REL, K8	FAILS CLOSED, APPL UNTIMELY PWR.
05-61C-MRL-6	4208	HYB REL, K64	FAILS CLOSED, APPL UNTIMELY PWR.
05-61C-MRL-6	4240	HYB REL, K43	FAILS CLOSED, APPL UNTIMELY PWR.
05-61C-MRL-6	4242	HYB REL, K57	FAILS CLOSED, APPL UNTIMELY PWR.
05-61C-MRL-6	4262	HYB REL, K73	FAILS CLOSED, APPL UNTIMELY PWR.
05-61C-MRL-6	4264	HYB REL, K76	FAILS CLOSED, APPL UNTIMELY PWR.
05-61C-MRL-6	4284	HYB REL, K66	FAILS CLOSED, APPL UNTIMELY PWR.
05-61C-MRL-6	4286	HYB REL, K44	FAILS CLOSED, APPL UNTIMELY PWR.
05-61C-MRL-6	4306	HYB REL, K71	FAILS CLOSED, APPL UNTIMELY PWR.
05-61C-MRL-6	4308	HYB REL, K74	FAILS CLOSED, APPL UNTIMELY PWR.
05-61C-MRL-6	4328	HYB REL, K12	FAILS CLOSED, APPL UNTIMELY PWR.
05-61C-MRL-6	4330	HYB REL, K29	FAILS CLOSED, APPL UNTIMELY PWR.
05-61C-MRL-2A	4346	SWITCH, S6	FAILS OPEN
05-61C-MRL-2B	4347	SWITCH, S6	FAILS CLOSED (ON)
05-61C-MRL-2D	4349	SWITCH, S6	PREMATURE CLOSE
05-61C-MRL-2E	4350	SWITCH, S6	CONTACT TO CONTACT SHORT
05-61C-MRL-2F	4351	SWITCH, S6	FAILS OPEN
05-61C-MRL-2G	4352	SWITCH, S6	POLE TO POLE SHORT

APPENDIX D: EPD&C/RMS 05-61D

NASA FMEA	IOA ID	ITEM NAME	FAILURE MODE
05-61D-2128-1	4209	RELAY, K44	FAILS CLOSED.
05-61D-2127-1	4243	RELAY, K57	FAILS CLOSED.
05-61D-2126-1	4265	RELAY, K77	FAILS OPEN.
05-61D-2128-1	4287	RELAY, K68	FAILS OPEN.
05-61D-2127-1	4309	RELAY, K78	FAILS OPEN.
05-61D-2126-1	4331	RELAY, K23	FAILS OPEN.
05-61D-2036-1	4501	SWITCH, S21	FAILS LOCKED IN SAFE POS.
05-61D-2036-2	4502	SWITCH, S21	FAILS CLOSED, APPL UNTIMELY PWR.
05-61D-2031-1	4503	SWITCH, S28	FAILS LOCKED IN SAFE POS.
05-61D-2031-2	4504	SWITCH, S28	FAILS CLOSED, APPL UNTIMELY PWR.
05-61D-2032-1	4505	SWITCH, S25	FAILS LOCKED IN SAFE POS.
05-61D-2032-2	4506	SWITCH, S25	FAILS CLOSED, APPL UNTIMELY PWR.
05-61D-2027-1	4507	SWITCH, S32	FAILS LOCKED IN SAFE POS.
05-61D-2027-2	4508	SWITCH, S32	FAILS CLOSED, APPL UNTIMELY PWR.
05-61D-2033-1	4509	SWITCH, S24	FAILS LOCKED IN SAFE POS.
05-61D-2033-2	4510	SWITCH, S24	FAILS CLOSED, APPL UNTIMELY PWR.
05-61D-2028-1	4511	SWITCH, S31	FAILS LOCKED IN SAFE POS.
05-61D-2028-2	4512	SWITCH, S31	FAILS CLOSED, APPL UNTIMELY PWR.
05-61D-2034-1	4513	SWITCH, S23	FAILS LOCKED IN SAFE POS.
05-61D-2034-2	4514	SWITCH, S23	FAILS CLOSED, APPL UNTIMELY PWR.
05-61D-2029-1	4515	SWITCH, S30	FAILS LOCKED IN SAFE POS.
05-61D-2029-2	4516	SWITCH, S30	FAILS CLOSED, APPL UNTIMELY PWR.
05-61D-2035-1	4517	SWITCH, S22	FAILS LOCKED IN SAFE POS.
05-61D-2035-2	4518	SWITCH, S22	FAILS CLOSED, APPL UNTIMELY PWR.
05-61D-2030-1	4519	SWITCH, S29	FAILS LOCKED IN SAFE POS.
05-61D-2030-2	4520	SWITCH, S29	FAILS CLOSED, APPL UNTIMELY PWR.
05-61D-2026-1	4521	SWITCH, S33	FAILS LOCKED IN SAFE POS.
05-61D-2003-1	4524	CKT BRK, CB27	FAILS OPEN. WILL NOT CLOSE.
05-61D-2002-1	4526	CKT BRK, CB29	FAILS OPEN. WILL NOT CLOSE.
05-61D-2003-1	4528	CKT BRK, CB33	FAILS OPEN. WILL NOT CLOSE.
05-61D-2002A-1	4530	CKT BRK, CB32	FAILS OPEN. WILL NOT CLOSE.
05-61D-2507-1	4532	PIC 1	FAILS TO ARM AND/OR FIRE.
05-61D-2515-1	4533	PIC 1	FAILS TO ARM AND/OR FIRE.
05-61D-2507-1	4534	PIC 12	FAILS TO ARM AND/OR FIRE.
05-61D-2515-1	4535	PIC 12	FAILS TO ARM AND/OR FIRE.
05-61D-2507-2	4536	PIC 1, 12	ARMS/FIRES PREMATURELY.
05-61D-2515-2	4537	PIC 1, 12	PIC ARMS/FIRES PREMATURELY.
05-61D-2505-1	4538	PIC 6	FAILS TO ARM AND/OR FIRE.
05-61D-2513-1	4539	PIC 6	FAILS TO ARM AND/OR FIRE.
05-61D-2505-1	4540	PIC 17	FAILS TO ARM AND/OR FIRE.
05-61D-2513-1	4541	PIC 17	FAILS TO ARM AND/OR FIRE.
05-61D-2505-2	4542	PIC 6, 17	ARMS/FIRES PREMATURELY.
05-61D-2513-2	4543	PIC 6, 17	ARMS/FIRES PREMATURELY.
05-61D-2503-1	4544	PIC 8	FAILS TO ARM AND/OR FIRE.
05-61D-2511-1	4545	PIC 8	FAILS TO ARM AND/OR FIRE.
05-61D-2503-1	4546	PIC 19	FAILS TO ARM AND/OR FIRE.
05-61D-2511-1	4547	PIC 19	FAILS TO ARM AND/OR FIRE.
05-61D-2503-2	4548	PIC 8, 19	PIC ARMS/FIRES PREMATURELY.

APPENDIX D: EPD&C/RMS 05-61D (Concluded)

NASA FMEA	IOA ID	ITEM NAME	FAILURE MODE
05-61D-2511-2	4549	PIC 8, 19	PIC ARMS/FIRES PREMATURELY.
05-61D-2501-1	4550	PIC 10	FAILS TO ARM AND/OR FIRE.
05-61D-2509-1	4551	PIC 10	FAILS TO ARM AND/OR FIRE.
05-61D-2501-1	4552	PIC 21	FAILS TO ARM AND/OR FIRE.
05-61D-2509-1	4553	PIC 21	FAILS TO ARM AND/OR FIRE.
05-61D-2501-2	4554	PIC 10, 21	PIC ARMS/FIRES PREMATURELY.
05-61D-2509-2	4555	PIC 10, 21	PIC ARMS/FIRES PREMATURELY.
05-61D-2506-1	4556	PIC 2	FAILS TO ARM AND/OR FIRE.
05-61D-2514-1	4557	PIC 2	FAILS TO ARM AND/OR FIRE.
05-61D-2506-1	4558	PIC 13	FAILS TO ARM AND/OR FIRE.
05-61D-2514-1	4559	PIC 13	FAILS TO ARM AND/OR FIRE.
05-61D-2506-2	4560	PIC 2, 13	PIC ARMS/FIRES PREMATURELY.
05-61D-2514-2	4561	PIC 2, 13	PIC ARMS/FIRES PREMATURELY.
05-61D-2504-1	4562	PIC 7	FAILS TO ARM/FIRE.
05-61D-2512-1	4563	PIC 7	FAILS TO ARM/FIRE.
05-61D-2504-1	4564	PIC 18	FAILS TO ARM/FIRE.
05-61D-2512-1	4565	PIC 18	FAILS TO ARM/FIRE.
05-61D-2504-2	4566	PIC 7, 18	PIC ARMS/FIRES PREMATURELY.
05-61D-2512-2	4567	PIC 7, 18	PIC ARMS/FIRES PREMATURELY.
05-61D-2502-1	4568	PIC 9	FAILS TO ARM/FIRE.
05-61D-2510-1	4569	PIC 9	FAILS TO ARM/FIRE.
05-61D-2502-1	4570	PIC 20	FAILS TO ARM/FIRE.
05-61D-2510-1	4571	PIC 20	FAILS TO ARM/FIRE.
05-61D-2502-2	4572	PIC 9, 20	PIC ARMS/FIRES PREMATURELY.
05-61D-2510-2	4573	PIC 9, 20	PIC ARMS/FIRES PREMATURELY.
05-61D-2500-1	4574	PIC 11	FAILS TO ARM/FIRE.
05-61D-2508-1	4575	PIC 11	FAILS TO ARM/FIRE.
05-61D-2500-1	4576	PIC 22	FAILS TO ARM/FIRE.
05-61D-2508-1	4577	PIC 22	FAILS TO ARM/FIRE.
05-61D-2500-2	4578	PIC 11, 22	PIC ARMS/FIRES PREMATURELY.
05-61D-2508-2	4579	PIC 11, 22	PIC ARMS/FIRES PREMATURELY.



**APPENDIX E
DETAILED ANALYSIS**

This appendix contains the IOA analysis worksheets supplementing previous results reported in STSEOS Working Paper 1.0-WP-VA86001-023, Analysis of the Remote Manipulator System, (12 January 1987). Prior results were obtained independently and documented before starting the FMEA/CIL assessment activity. Supplemental analysis was performed to address failure modes not previously considered by the IOA. Each sheet identifies the hardware item being analyzed, parent assembly and function performed. For each failure mode possible causes are identified, and hardware and functional criticality for each mission phase are determined as described in NSTS 22206, Instructions for Preparation of FMEA and CIL, 10 October 1986. Failure mode effects are described at the bottom of each sheet and worst case criticality is identified at the top.

LEGEND FOR IOA ANALYSIS WORKSHEETS

Hardware Criticalities:

- 1 = Loss of life or vehicle
- 2 = Loss of mission or next failure of any redundant item (like or unlike) could cause loss of life/vehicle
- 3 = All others

Functional Criticalities:

- 1R = Redundant hardware items (like or unlike) all of which, if failed, could cause loss of life or vehicle.
- 2R = Redundant hardware items (like or unlike) all of which, if failed, could cause loss of mission.

Redundancy Screen A:

- 1 = Is Checked Out PreFlight
- 2 = Is Capable of Check Out PreFlight
- 3 = Not Capable of Check Out PreFlight
- NA = Not Applicable

Redundancy Screens B and C:

- P = Passed Screen
- F = Failed Screen
- NA = Not Applicable

**INDEPENDENT ORBITER ASSESSMENT
ORBITER SUBSYSTEM ANALYSIS WORKSHEET**

DATE: 2/01/88 HIGHEST CRITICALITY HDW/FUNC
 SUBSYSTEM: RMS/EPD&C FLIGHT: 1/1
 MDAC ID: 4049 ABORT: /NA

ITEM: SWITCH, S4
 FAILURE MODE: POLE TO POLE SHORT, CONTACT TO CONTACT SHORT,
 SHORT TO CASE

LEAD ANALYST: ROBINSON SUBSYS LEAD: SCHMECKPEPER

BREAKDOWN HIERARCHY:

- 1) RMS, 05-6IA
- 2) REMOTE MANIPULATOR ARM
- 3) PANEL A8A2
- 4) RMS POWER SWITCH, PRIMARY/OFF/BACKUP
- 5) SWITCH, TOGGLE, MAINTAINED
- 6) SWITCH, 4-POLE, 3-POSITION
- 7) SWITCH, S4
- 8)
- 9)

FLIGHT PHASE	CRITICALITIES		
	HDW/FUNC	ABORT	HDW/FUNC
PRELAUNCH:	/NA	RTLS:	/NA
LIFTOFF:	/NA	TAL:	/NA
ONORBIT:	1/1	AOA:	/NA
DEORBIT:	/NA	ATO:	/NA
LANDING/SAFING:	/NA		

REDUNDANCY SCREENS: A [] B [] C []

LOCATION: 36V73A8A2S4
 PART NUMBER: ME452-0102-7403

CAUSES: PIECE PART STRUCTURAL FAILURE

EFFECTS/RATIONALE:

LOSS OF ABILITY TO PROVIDE EITHER PRIMARY OR BACKUP 28 VDC AND 115 VAC POWER TO EITHER THE PORT OR STBD REMOTE MANIPULATOR ARM.
 LOSS OF POWER TO AN RMS IN USE COULD REQUIRE JETTISON OF THE RMS IF SAFE JETTISON IS AN OPTION. IF THE RMS CANNOT BE SAFELY JETTISONED, LOSS OF VEHICLE/CREW COULD RESULT.

REFERENCES: VS72-956099, ROCKWELL ELECTRICAL SCHEMATIC, RMS JSC-11174, SPACE SHUTTLE SYSTEMS HANDBOOK

INDEPENDENT ORBITER ASSESSMENT
ORBITER SUBSYSTEM ANALYSIS WORKSHEET

DATE: 2/10/88	HIGHEST CRITICALITY	HDW/FUNC
SUBSYSTEM: RMS/EPD&C	FLIGHT:	3/3
MDAC ID: 4050	ABORT:	/NA

ITEM: RESISTOR, A2R2, A2R3, A3R2, A3R3
FAILURE MODE: SHORTED

LEAD ANALYST: ROBINSON SUBSYS LEAD: SCHMECKPEPER

BREAKDOWN HIERARCHY:

- 1) RMS, 05-6IA
- 2) REMOTE MANIPULATOR ARM
- 3) PANEL A8A2
- 4) STBD & PORT HEATER
- 5) RESISTOR, CURRENT LIMITING
- 6) RESISTOR, 1.2K OHM, 2 WATT
- 7) RESISTOR, A2R2, A2R3, A3R2, A3R3
- 8)
- 9)

FLIGHT PHASE	HDW/FUNC	CRITICALITIES	ABORT	HDW/FUNC
PRELAUNCH:	/NA		RTLS:	/NA
LIFTOFF:	/NA		TAL:	/NA
ONORBIT:	3/3		AOA:	/NA
DEORBIT:	/NA		ATO:	/NA
LANDING/SAFING:	/NA			

REDUNDANCY SCREENS: A [] B [] C []

LOCATION: 36V73A8A2A2R2, A2R3, A3R2, A3R3
PART NUMBER: RWR80S1211FR (4 EACH)

CAUSES: CONTAMINATION, VIBRATION, MECHANICAL SHOCK

EFFECTS/RATIONALE:

LOSE CURRENT LIMITING CIRCUIT PROTECTION FOR HEATER INPUT POWER CONTROL CIRCUITS.

REFERENCES: VS72-956099, ROCKWELL ELECTRICAL SCHEMATIC, RMS
JSC-11174, SPACE SHUTTLE SYSTEMS HANDBOOK

INDEPENDENT ORBITER ASSESSMENT
ORBITER SUBSYSTEM ANALYSIS WORKSHEET

DATE: 2/10/88
 SUBSYSTEM: RMS/EPD&C
 MDAC ID: 4051

HIGHEST CRITICALITY HDW/FUNC
 FLIGHT: 3/3
 ABORT: /NA

ITEM: CIRCUIT BREAKER, 1 PH 3A RMS, BACKUP POWER
 FAILURE MODE: FAILS CLOSED, FAIL TO TRIPP ON OVERLOAD, PREMATURE CLOSED

LEAD ANALYST: ROBINSON SUBSYS LEAD: SCHMECKPEPER

BREAKDOWN HIERARCHY:

- 1) RMS, 05-6IA
- 2) REMOTE MANIPULATOR ARM
- 3) PANEL M73C
- 4) AC SYSTEM 2 POWER
- 5) CIRCUIT BREAKER, 1-PH, 3 AMP
- 6) CIRCUIT BREAKER, CB19
- 7)
- 8)
- 9)

FLIGHT PHASE	CRITICALITIES		
	HDW/FUNC	ABORT	HDW/FUNC
PRELAUNCH:	/NA	RTLS:	/NA
LIFTOFF:	/NA	TAL:	/NA
ONORBIT:	3/3	AOA:	/NA
DEORBIT:	/NA	ATO:	/NA
LANDING/SAFING:	/NA		

REDUNDANCY SCREENS: A [] B [] C []

LOCATION: 85V73A129CB19
 PART NUMBER: MC454-0026-2030

CAUSES: CONTAMINATION, PIECE PART STRUCTURAL FAILURE, MECHANICAL SHOCK, VIBRATION

EFFECTS/RATIONALE:

LOSS OF ABILITY TO PROVIDE CIRCUIT PROTECTION FOR BACKUP AC POWER (SYSTEM 2) TO THE RMS LOAD PANEL A8A1 POWER CONTROL CIRCUIT. POWER CAN BE REMOVED BY SWITCH.

CIRCUIT BREAKER IS NORMALLY CLOSED THUS THE FAILURE COULD REMAIN UNDETECTED UNTIL POWERDOWN OF CIRCUIT.

REFERENCES: VS72-956099, ROCKWELL ELECTRICAL SCHEMATIC, RMS JSC-11174, SPACE SHUTTLE SYSTEMS HANDBOOK

INDEPENDENT ORBITER ASSESSMENT
ORBITER SUBSYSTEM ANALYSIS WORKSHEET

DATE:	1/27/88	HIGHEST CRITICALITY	HDW/FUNC
SUBSYSTEM:	RMS/EPD&C	FLIGHT:	3/3
MDAC ID:	4052	ABORT:	/NA

ITEM: REMOTE POWER CONTROLLER, RPC 4
FAILURE MODE: INADVERTENT OUTPUT

LEAD ANALYST: ROBINSON SUBSYS LEAD: SCHMECKPEPER

BREAKDOWN HIERARCHY:

- 1) RMS, 05-6IA
- 2) REMOTE MANIPULATOR ARM
- 3) MCIU PRIMARY POWER (MN A)
- 4) FWD POWER CONTROLLER ASSY (MPC) 1
- 5) REMOTE POWER CONTROLLER, 10 AMP
- 6) REMOTE POWER CONTROLLER, RPC 4
- 7)
- 8)
- 9)

CRITICALITIES

FLIGHT PHASE	HDW/FUNC	ABORT	HDW/FUNC
PRELAUNCH:	/NA	RTLS:	/NA
LIFTOFF:	/NA	TAL:	/NA
ONORBIT:	3/3	AOA:	/NA
DEORBIT:	/NA	ATO:	/NA
LANDING/SAFING:	/NA		

REDUNDANCY SCREENS: A [] B [] C []

LOCATION: 81V76A22RPC4
PART NUMBER: MC450-0017-1100

CAUSES: CONTAMINATION, PIECE PART FAILURE STRUCTURAL FAILURE,
MECHANICAL SHOCK, VIBRATION, THERMAL SHOCK.

EFFECTS/RATIONALE:

FAILURE WILL RESULT IN MCIU BEING CONTINUOUSLY POWERED. THIS IS
THE NOMINAL CONDITION DURING ON-ORBIT PHASE OF FLIGHT.
FAILURE WILL NOT AFFECT OPERATIONS OR BE APPARENT ONBOARD.

REFERENCES: VS72-956099, ROCKWELL ELECTRICAL SCHEMATIC, RMS
JSC-11174, SPACE SHUTTLE SYSTEMS HANDBOOK

**INDEPENDENT ORBITER ASSESSMENT
ORBITER SUBSYSTEM ANALYSIS WORKSHEET**

DATE: 11/04/86 HIGHEST CRITICALITY HDW/FUNC
 SUBSYSTEM: RMS/EPD&C FLIGHT: 3/1R
 MDAC ID: 4053 ABORT: /NA

ITEM: REMOTE POWER CONTROLLER, RPC 26, 27, 28, 29
 FAILURE MODE: OPEN, FAILS TO CLOSE.

LEAD ANALYST: ROBINSON SUBSYS LEAD: SCHMECKPEPER

BREAKDOWN HIERARCHY:

- 1) RMS, 05-6IA
- 2) REMOTE MANIPULATOR ARM
- 3) PORT/STBD HEATER A/B POWER
- 4) MID POWER CONTROLLER ASSY (MPC)
- 5) REMOTE POWER CONTROLLER, 20 AMP
- 6) REMOTE POWER CONTROLLER, RPC 27
- 7)
- 8)
- 9)

CRITICALITIES			
FLIGHT PHASE	HDW/FUNC	ABORT	HDW/FUNC
PRELAUNCH:	/NA	RTLS:	/NA
LIFTOFF:	/NA	TAL:	/NA
ONORBIT:	3/1R	AOA:	/NA
DEORBIT:	/NA	ATO:	/NA
LANDING/SAFING:	/NA		

REDUNDANCY SCREENS: A [] B [P] C [F]

LOCATION: 40V76A25RPC27
 PART NUMBER: MC450-0017-1200

CAUSES: MECHANICAL/STRUCTURAL MALFUNCTION, SHOCK, VIBRATION,
 CORROSION, CONTAMINATION

EFFECTS/RATIONALE:

LOSS OF ABILITY TO PROVIDE HEATER A (28 VDC MN A) POWER TO PORT
 REMOTE MANIPULATOR ARM.

LOSS OF HEATER POWER B TO PORT MANIPULATOR ARM COULD RESULT IN
 LOSS OF MANIPULATOR POSITIONING CAPABILITY, THUS LOSS OF MISSION
 COULD RESULT.

SUBSEQUENT LOSS COULD CAUSE FROZEN JOINT WHICH COULD RESULT IN
 UNCOMMANDDE MOTION WHICH COULD RESULT IN LOSS OF CREW/ VEHICLE.

REFERENCES: VS72-956099, ROCKWELL ELECTRICAL SCHEMATIC, RMS
 JSC-11174, SPACE SHUTTLE SYSTEMS HANDBOOK

INDEPENDENT ORBITER ASSESSMENT
ORBITER SUBSYSTEM ANALYSIS WORKSHEET

DATE:	11/05/86	HIGHEST CRITICALITY	HDW/FUNC
SUBSYSTEM:	RMS/EPD&C	FLIGHT:	2/1R
MDAC ID:	4054	ABORT:	/NA

ITEM: REMOTE POWER CONTROLLER, RPC 30, RPC 31
FAILURE MODE: OPEN, FAILS TO CLOSE.

LEAD ANALYST: ROBINSON SUBSYS LEAD: SCHMECKPEPER

BREAKDOWN HIERARCHY:

- 1) RMS, 05-6IA
- 2) REMOTE MANIPULATOR ARM
- 3) PORT/STBD BACKUP POWER
- 4) MID POWER CONTROLLER ASSY (MPC)
- 5) REMOTE POWER CONTROLLER, 10 AMP
- 6) REMOTE POWER CONTROLLER, RPC 30, RPC 31
- 7)
- 8)
- 9)

FLIGHT PHASE	CRITICALITIES HDW/FUNC	ABORT	HDW/FUNC
PRELAUNCH:	/NA	RTLS:	/NA
LIFTOFF:	/NA	TAL:	/NA
ONORBIT:	2/1R	AOA:	/NA
DEORBIT:	/NA	ATO:	/NA
LANDING/SAFING:	/NA		

REDUNDANCY SCREENS: A [1] B [F] C [P]

LOCATION: 40V76A26RPC30, 31
PART NUMBER: MC450-0017-1100

CAUSES: MECHANICAL/STRUCTURAL MALFUNCTION, SHOCK, VIBRATION,
CORROSION, CONTAMINATION

EFFECTS/RATIONALE:

LOSS OF BACKUP (28 VDC MN B) POWER TO PORT/STBD REMOTE MANIPULATOR ARM PRIOR TO START OF ARM DEPLOYMENT WOULD NEGATE USE OF ARM THUS LOSS OF MISSION.

LOSS OF BACKUP POWER PRIOR TO DEPLOYMENT OR WHILE ARM IS IN USE WOULD ABORT OPERATION OF ARM THUS LOSS OF MISSION. LOSS OF BACKUP AFTER LOSS OF PRIMARY WHILE ARM IS IN USE COULD RESULT IN LOSS OF CREW/VEHICLE IF ARM CANNOT BE SAFELY JETTISONED.

REFERENCES: VS72-956099, ROCKWELL ELECTRICAL SCHEMATIC, RMS JSC-11174, SPACE SHUTTLE SYSTEMS HANDBOOK

INDEPENDENT ORBITER ASSESSMENT
ORBITER SUBSYSTEM ANALYSIS WORKSHEET

DATE: 1/29/88 HIGHEST CRITICALITY HDW/FUNC
SUBSYSTEM: RMS/EPD&C FLIGHT: 3/3
MDAC ID: 4175 ABORT: /NA

ITEM: SWITCH, S2
FAILURE MODE: PREMATURE OPEN

LEAD ANALYST: ROBINSON SUBSYS LEAD: SCHMECKPEPER

BREAKDOWN HIERARCHY:

- 1) RMS, 05-6IB
- 2) MANIPULATOR DEPLOY CONTROL
- 3) PANEL A8A2
- 4) STBD RMS DEPLOY/STOW
- 5) SWITCH, TOGGLE, MAINTAINED
- 6) SWITCH. 2-POLE, 2-POS
- 7) SWITCH, S2
- 8)
- 9)

FLIGHT PHASE	CRITICALITIES		
	HDW/FUNC	ABORT	HDW/FUNC
PRELAUNCH:	/NA	RTLS:	/NA
LIFTOFF:	/NA	TAL:	/NA
ONORBIT:	2/2	AOA:	/NA
DEORBIT:	/NA	ATO:	/NA
LANDING/SAFING:	/NA		

REDUNDANCY SCREENS: A [] B [] C []

LOCATION: 32V73A8A2S2
PART NUMBER: ME452-0102-7201

CAUSES: MECHANICAL/STRUCTURAL MALFUNCTION, SHOCK, VIBRATION,
CORROSION, CONTAMINATION

EFFECTS/RATIONALE:

INABILITY TO PROVIDE CONTROL VOLTAGE TO OPERATE THE STOW/DEPLOY ACTUATOR.

INITIAL FAILURE WOULD BE APPARENT ONBOARD FROM EXTENDED AMOUNT OF TIME REQUIRED TO STOW/DEPLOY MPM. RMS OPERATIONS CAN CONTINUE OF SHOULDER HOOK IS ENGAGED.

REFERENCES: VS72-956099, ROCKWELL ELECTRICAL SCHEMATIC, RMS JSC-11174, SPACE SHUTTLE SYSTEMS HANDBOOK

INDEPENDENT ORBITER ASSESSMENT
ORBITER SUBSYSTEM ANALYSIS WORKSHEET

DATE: 1/28/88 HIGHEST CRITICALITY HDW/FUNC
SUBSYSTEM: RMS/EPD&C FLIGHT: 2/1R
MDAC ID: 4176 ABORT: /NA

ITEM: SWITCH, S2
FAILURE MODE: SHORTS TO GROUND

LEAD ANALYST: ROBINSON SUBSYS LEAD: SCHMECKPEPER

BREAKDOWN HIERARCHY:

- 1) RMS, 05-6IB
- 2) MANIPULATOR DEPLOY CONTROL
- 3) PANEL A8A2
- 4) STBD RMS DEPLOY/STOW
- 5) SWITCH, TOGGLE, MAINTAINED
- 6) SWITCH. 2-POLE, 2-POS
- 7) SWITCH, S2
- 8)
- 9)

CRITICALITIES			
FLIGHT PHASE	HDW/FUNC	ABORT	HDW/FUNC
PRELAUNCH:	/NA	RTLS:	/NA
LIFTOFF:	/NA	TAL:	/NA
ONORBIT:	2/1R	AOA:	/NA
DEORBIT:	/NA	ATO:	/NA
LANDING/SAFING:	/NA		

REDUNDANCY SCREENS: A [1] B [P] C [P]

LOCATION: 32V73A8A2S2
PART NUMBER: ME452-0102-7201

CAUSES: MECHANICAL/STRUCTURAL MALFUNCTION, SHOCK, VIBRATION,
CORROSION, CONTAMINATION

EFFECTS/RATIONALE:

INABILITY TO PROVIDE CONTROL VOLTAGE TO OPERATE THE STOW/DEPLOY ACTUATOR.

LOSS OF OPERATION OF THE STOW/DEPLOY ACTUATOR COULD CAUSE LOSS OF MISSION AND POSSIBLY REQUIRE JETTISON OF THE REMOTE MANIPULATOR ARM IF IT CANNOT BE SAFELY STOWED.

COULD RESULT IN LOSS OF CREW/VEHICLE IF THE ARM CANNOT BE SAFELY JETTISONED.

REFERENCES: VS72-956099, ROCKWELL ELECTRICAL SCHEMATIC, RMS JSC-11174, SPACE SHUTTLE SYSTEMS HANDBOOK

INDEPENDENT ORBITER ASSESSMENT
ORBITER SUBSYSTEM ANALYSIS WORKSHEET

DATE:	2/24/88	HIGHEST CRITICALITY	HDW/FUNC
SUBSYSTEM:	RMS/EPD&C	FLIGHT:	3/3
MDAC ID:	4177	ABORT:	/NA

ITEM: RESISTORS, 2W, (6 EACH)
FAILURE MODE: FAILS OPEN

LEAD ANALYST: ROBINSON SUBSYS LEAD: SCHMECKPEPER

BREAKDOWN HIERARCHY:

- 1) RMS, 05-6IB
- 2) MANIPULATOR DEPLOY CONTROL
- 3) PEDESTAL DEPLOY/STOW
- 4) RESISTORS, CURRENT LIMITING
- 5) RESISTORS, 2W, (6 EACH)
- 6)
- 7)
- 8)
- 9)

FLIGHT PHASE	CRITICALITIES		HDW/FUNC
	HDW/FUNC	ABORT	
PRELAUNCH:	/NA	RTLS:	/NA
LIFTOFF:	/NA	TAL:	/NA
ONORBIT:	1/1	AOA:	/NA
DEORBIT:	/NA	ATO:	/NA
LANDING/SAFING:	/NA		

REDUNDANCY SCREENS: A [] B [] C []

LOCATION:
PART NUMBER:

CAUSES: VIBRATION, TEMPERATURE, MECHANICAL SHOCK, OVERVOLTAGE

EFFECTS/RATIONALE:

LOSS OF POSITION OF PEDESTALS INDICATION.
PEDESTAL POSITION IS NOT USED IN SYSTEM LOGIC CONTROL.

REFERENCES: VS72-956099, ROCKWELL ELECTRICAL SCHEMATIC, RMS
JSC-11174, SPACE SHUTTLE SYSTEMS HANDBOOK

INDEPENDENT ORBITER ASSESSMENT
ORBITER SUBSYSTEM ANALYSIS WORKSHEET

DATE:	2/24/88	HIGHEST CRITICALITY	HDW/FUNC
SUBSYSTEM:	RMS/EPD&C	FLIGHT:	3/1R
MDAC ID:	4178	ABORT:	/NA

ITEM: RESISTORS, 1.2 KOHM, 2W, (2 EACH)
FAILURE MODE: FAILS OPEN

LEAD ANALYST: ROBINSON SUBSYS LEAD: SCHMECKPEPER

BREAKDOWN HIERARCHY:

- 1) RMS, 05-6IB
- 2) MANIPULATOR DEPLOY CONTROL
- 3) SHOULDER POSITION MICROSWITCHES
- 4) RESISTORS, CURRENT LIMITING
- 5) RESISTORS, 1.2 KOHM, 2W, (2 EACH)
- 6)
- 7)
- 8)
- 9)

CRITICALITIES			
FLIGHT PHASE	HDW/FUNC	ABORT	HDW/FUNC
PRELAUNCH:	/NA	RTLS:	/NA
LIFTOFF:	/NA	TAL:	/NA
ONORBIT:	3/1R	AOA:	/NA
DEORBIT:	/NA	ATO:	/NA
LANDING/SAFING:	/NA		

REDUNDANCY SCREENS: A [1] B [P] C [P]

LOCATION:
PART NUMBER:

CAUSES: VIBRATION, TEMPERATURE, MECHANICAL SHOCK, OVERVOLTAGE

EFFECTS/RATIONALE:

FAILURE WILL RESULT IN ONE SYSTEM OF STOW/DEPLOY MICROSWITCHES INDICATING SHOULDER NOT STOWED/DEPLOYED REGARDLESS OF THE ACTUAL SITUATION. THIS WILL ALLOW THE ASSOCIATED MOTOR TO RUN UNTIL THE COMMAND IS REMOVED.

SUBSEQUENT FAILURE OF DRIVE AND POWER SWITCHES WILL ALLOW CONTINUOUS MOTOR RUNNING TO STALL/BURNOUT RESULTING IN LOSS OF MISSION. SUBSEQUENT FAILURE COULD REQUIRE JETTISON OF THE RMS. IF SAFE JETTISON CANNOT BE PERFORMED THEN LOSS OF CREW/VEHICLE COULD RESULT.

REFERENCES: VS72-956099, ROCKWELL ELECTRICAL SCHEMATIC, RMS JSC-11174, SPACE SHUTTLE SYSTEMS HANDBOOK

INDEPENDENT ORBITER ASSESSMENT
ORBITER SUBSYSTEM ANALYSIS WORKSHEET

DATE: 2/24/88
 SUBSYSTEM: RMS/EPD&C
 MDAC ID: 4179

HIGHEST CRITICALITY
 FLIGHT: 3/1R
 ABORT: /NA

ITEM: LIMIT SWITCHES (2 EACH)
 FAILURE MODE: FAILS OPEN

LEAD ANALYST: ROBINSON SUBSYS LEAD: SCHMECKPEPER

BREAKDOWN HIERARCHY:

- 1) RMS, 05-6IB
- 2) MANIPULATOR DEPLOY CONTROL
- 3) SHOULDER POSITION MICROSWITCHES
- 4) LIMIT SWITCH, DEPLOY SHOULDER
- 5) LIMIT SWITCHES (2 EACH)
- 6)
- 7)
- 8)
- 9)

FLIGHT PHASE	CRITICALITIES		
	HDW/FUNC	ABORT	HDW/FUNC
PRELAUNCH:	/NA	RTLS:	/NA
LIFTOFF:	/NA	TAL:	/NA
ONORBIT:	3/1R	AOA:	/NA
DEORBIT:	/NA	ATO:	/NA
LANDING/SAFING:	/NA		

REDUNDANCY SCREENS: A [1] B [P] C [P]

LOCATION:
 PART NUMBER:

CAUSES: VIBRATION, TEMPERATURE, MECHANICAL SHOCK, OVERVOLTAGE

EFFECTS/RATIONALE:

FAILURE WILL RESULT IN ONE SYSTEM OF STOW/DEPLOY MICROSWITCHES INDICATING SHOULDER NOT STOWED/DEPLOYED REGARDLESS OF THE ACTUAL SITUATION. THIS WILL ALLOW THE ASSOCIATED MOTOR TO RUN UNTIL THE COMMAND IS REMOVED.

SUBSEQUENT FAILURE OF DRIVE AND POWER SWITCHES WILL ALLOW CONTINUOUS MOTOR RUNNING TO STALL/BURNOUT RESULTING IN LOSS OF MISSION. SUBSEQUENT FAILURE COULD REQUIRE JETTISON OF THE RMS.

IF SAFE JETTISON CANNOT BE PERFORMED THEN LOSS OF CREW/VEHICLE COULD RESULT.

REFERENCES: VS72-956099, ROCKWELL ELECTRICAL SCHEMATIC, RMS JSC-11174, SPACE SHUTTLE SYSTEMS HANDBOOK

INDEPENDENT ORBITER ASSESSMENT
ORBITER SUBSYSTEM ANALYSIS WORKSHEET

DATE:	2/24/88	HIGHEST CRITICALITY	HDW/FUNC
SUBSYSTEM:	RMS/EPD&C	FLIGHT:	3/2R
MDAC ID:	4180	ABORT:	/NA

ITEM: LIMIT SWITCHES (2 EACH)
FAILURE MODE: FAILS CLOSED

LEAD ANALYST: ROBINSON SUBSYS LEAD: SCHMECKPEPER

BREAKDOWN HIERARCHY:

- 1) RMS, 05-6IB
- 2) MANIPULATOR DEPLOY CONTROL
- 3) SHOULDER POSITION MICROSWITCHES
- 4) LIMIT SWITCH, DEPLOY SHOULDER
- 5) LIMIT SWITCHES (2 EACH)
- 6)
- 7)
- 8)
- 9)

FLIGHT PHASE	CRITICALITIES		HDW/FUNC
	HDW/FUNC	ABORT	
PRELAUNCH:	/NA	RTLS:	/NA
LIFTOFF:	/NA	TAL:	/NA
ONORBIT:	3/2R	AOA:	/NA
DEORBIT:	/NA	ATO:	/NA
LANDING/SAFING:	/NA		

REDUNDANCY SCREENS: A [1] B [P] C [P]

LOCATION:
PART NUMBER:

CAUSES: FAILURE/DEFLECTION OF INTERNAL PART, VIBRATION,
CONTAMINATION /FORIEGN OBJECT /DEBRIS

EFFECTS/RATIONALE:

FAILURE WILL RESULT IN ONE SYSTEM OF STOW/DEPLOY MICROSWITCHES INDICATING SHOULDER NOT STOWED/DEPLOYED REGARDLESS OF THE ACTUAL SITUATION. THIS WILL ALLOW THE ASSOCIATED MOTOR TO RUN UNTIL THE COMMAND IS REMOVED.

SUBSEQUENT FAILURE OF THE OTHER DEPLOY MICROSWITCH WILL RESULT IN LOSS OF MISSION.

REFERENCES: VS72-956099, ROCKWELL ELECTRICAL SCHEMATIC, RMS
JSC-11174, SPACE SHUTTLE SYSTEMS HANDBOOK

INDEPENDENT ORBITER ASSESSMENT
ORBITER SUBSYSTEM ANALYSIS WORKSHEET

DATE:	2/24/88	HIGHEST CRITICALITY	HDW/FUNC
SUBSYSTEM:	RMS/EPD&C	FLIGHT:	3/1R
MDAC ID:	4181	ABORT:	/NA

ITEM: LIMIT SWITCHES (2 EACH)
FAILURE MODE: FAILS OPEN

LEAD ANALYST: ROBINSON SUBSYS LEAD: SCHMECKPEPER

BREAKDOWN HIERARCHY:

- 1) RMS, 05-6IB
- 2) MANIPULATOR DEPLOY CONTROL
- 3) SHOULDER POSITION MICROSWITCHES
- 4) LIMIT SWITCH, STOW SHOULDER
- 5) LIMIT SWITCHES (2 EACH)
- 6)
- 7)
- 8)
- 9)

FLIGHT PHASE	CRITICALITIES		
	HDW/FUNC	ABORT	HDW/FUNC
PRELAUNCH:	/NA	RTLS:	/NA
LIFTOFF:	/NA	TAL:	/NA
ONORBIT:	3/2R	AOA:	/NA
DEORBIT:	/NA	ATO:	/NA
LANDING/SAFING:	/NA		

REDUNDANCY SCREENS: A [1] B [P] C [P]

LOCATION:
PART NUMBER:

CAUSES: FAILURE/DEFLECTION OF INTERNAL PART, VIBRATION,
CONTAMINATION /FORIEGN OBJECT /DEBRIS

EFFECTS/RATIONALE:

FAILURE WILL RESULT IN ONE SYSTEM OF STOW/DEPLOY MICROSWITCHES INDICATING SHOULDER NOT STOWED/DEPLOYED REGARDLESS OF THE ACTUAL SITUATION. THIS WILL ALLOW THE ASSOCIATED MOTOR TO RUN UNTIL THE COMMAND IS REMOVED.

SUBSEQUENT FAILURE OF THE OTHER DEPLOY MICROSWITCH WILL RESULT IN LOSS OF MISSION.

REFERENCES: VS72-956099, ROCKWELL ELECTRICAL SCHEMATIC, RMS JSC-11174, SPACE SHUTTLE SYSTEMS HANDBOOK

INDEPENDENT ORBITER ASSESSMENT
ORBITER SUBSYSTEM ANALYSIS WORKSHEET

DATE:	2/24/88	HIGHEST CRITICALITY	HDW/FUNC
SUBSYSTEM:	RMS/EPD&C	FLIGHT:	3/1R
MDAC ID:	4182	ABORT:	/NA

ITEM: LIMIT SWITCHES (2 EACH)
FAILURE MODE: FAILS CLOSED

LEAD ANALYST: ROBINSON SUBSYS LEAD: SCHMECKPEPER

BREAKDOWN HIERARCHY:

- 1) RMS, 05-6IB
- 2) MANIPULATOR DEPLOY CONTROL
- 3) SHOULDER POSITION MICROSWITCHES
- 4) LIMIT SWITCH, STOW SHOULDER
- 5) LIMIT SWITCHES (2 EACH)
- 6)
- 7)
- 8)
- 9)

	CRITICALITIES		
FLIGHT PHASE	HDW/FUNC	ABORT	HDW/FUNC
PRELAUNCH:	/NA	RTLS:	/NA
LIFTOFF:	/NA	TAL:	/NA
ONORBIT:	3/1R	AOA:	/NA
DEORBIT:	/NA	ATO:	/NA
LANDING/SAFING:	/NA		

REDUNDANCY SCREENS: A [1] B [P] C [P]

LOCATION:
PART NUMBER:

CAUSES: VIBRATION, TEMPERATURE, MECHANICAL SHOCK, OVERVOLTAGE

EFFECTS/RATIONALE:

FAILURE WILL RESULT IN ONE SYSTEM OF STOW/DEPLOY MICROSWITCHES INDICATING SHOULDER NOT STOWED/DEPLOYED REGARDLESS OF THE ACTUAL SITUATION. THIS WILL ALLOW THE ASSOCIATED MOTOR TO RUN UNTIL THE COMMAND IS REMOVED.

SUBSEQUENT FAILURE OF DRIVE AND POWER SWITCHES WILL ALLOW CONTINUOUS MOTOR RUNNING TO STALL/BURNOUT RESULTING IN LOSS OF MISSION. SUBSEQUENT FAILURE COULD REQUIRE JETTISON OF THE RMS.

IF SAFE JETTISON CANNOT BE PERFORMED THEN LOSS OF CREW/VEHICLE COULD RESULT.

REFERENCES: VS72-956099, ROCKWELL ELECTRICAL SCHEMATIC, RMS JSC-11174, SPACE SHUTTLE SYSTEMS HANDBOOK

INDEPENDENT ORBITER ASSESSMENT
ORBITER SUBSYSTEM ANALYSIS WORKSHEET

DATE: 1/19/88 HIGHEST CRITICALITY HDW/FUNC
SUBSYSTEM: RMS/EPD&C FLIGHT: 3/3
MDAC ID: 4183 ABORT: /NA

ITEM: RESISTORS, (16 EACH)
FAILURE MODE: FAILS OPEN

LEAD ANALYST: ROBINSON SUBSYS LEAD: SCHMECKPEPER

BREAKDOWN HIERARCHY:

- 1) RMS, 05-6IB
- 2) MANIPULATOR POSITIONING MECHANISM
- 3) MPM POSITION INDICATION CIRCUIT
- 4) ISOLATION RESISTORS
- 5) RESISTORS, 5.1 KOHM, 1/4 WATT
- 6) RESISTORS, (16 EACH)
- 7)
- 8)
- 9)

FLIGHT PHASE	CRITICALITIES		
	HDW/FUNC	ABORT	HDW/FUNC
PRELAUNCH:	/NA	RTLS:	/NA
LIFTOFF:	/NA	TAL:	/NA
ONORBIT:	3/3	AOA:	/NA
DEORBIT:	/NA	ATO:	/NA
LANDING/SAFING:	/NA		

REDUNDANCY SCREENS: A [] B [] C []

LOCATION:
PART NUMBER:

CAUSES: MECHANICAL/STRUCTURAL MALFUNCTION, SHOCK, VIBRATION,
CORROSION, CONTAMINATION

EFFECTS/RATIONALE:
FAILURE WOULD RESULT IN LOSS OF MPM POSITION INDICATIONS.

REFERENCES: VS72-956099, ROCKWELL ELECTRICAL SCHEMATIC, RMS
JSC-11174, SPACE SHUTTLE SYSTEMS HANDBOOK

INDEPENDENT ORBITER ASSESSMENT
ORBITER SUBSYSTEM ANALYSIS WORKSHEET

DATE:	2/17/88	HIGHEST CRITICALITY	HDW/FUNC
SUBSYSTEM:	RMS/EPD&C	FLIGHT:	3/1R
MDAC ID:	4345	ABORT:	/NA

ITEM: FUSE, F3, F4
FAILURE MODE: FAILS OPEN.

LEAD ANALYST: ROBINSON SUBSYS LEAD: SCHMECKPEPER

BREAKDOWN HIERARCHY:

- 1) RMS, 05-6IC
- 2) MANIPULATOR LATCH CONTROL
- 3) FUSE, 1 AMP
- 4) FUSE, F3, F4
- 5)
- 6)
- 7)
- 8)
- 9)

	CRITICALITIES		
FLIGHT PHASE	HDW/FUNC	ABORT	HDW/FUNC
PRELAUNCH:	/NA	RTLS:	/NA
LIFTOFF:	/NA	TAL:	/NA
ONORBIT:	3/1R	AOA:	/NA
DEORBIT:	/NA	ATO:	/NA
LANDING/SAFING:	/NA		

REDUNDANCY SCREENS: A [1] B [P] C [P]

LOCATION: 36V73AKA2F3, F4
PART NUMBER: MC451-0018-0100

CAUSES: MECHANICAL SHOCK, OVERLOAD

EFFECTS/RATIONALE:

FAILURE OF THE FUSE WILL RESULT IN LOSS OF ABILITY TO DRIVE ONE OF THE MRL MOTORS AT EACH PEDESTAL. SUBSEQUENT FAILURE OF ASSOCIATED FUSE MAY REQUIRE JETTISON OF THE RMS TO PREVENT DAMAGE THAT COULD OCCUR FROM UNRESTRAINED RMS DURING ENTRY.

POSSIBLE LOSS OF CREW/VEHICLE IF THE RMS COULD NOT BE SAFELY JETTISONED.

REFERENCES: VS72-956099, ROCKWELL ELECTRICAL SCHEMATIC, RMS
JSC-11174, SPACE SHUTTLE SYSTEMS HANDBOOK

INDEPENDENT ORBITER ASSESSMENT
ORBITER SUBSYSTEM ANALYSIS WORKSHEET

DATE: 2/17/88 HIGHEST CRITICALITY HDW/FUNC
SUBSYSTEM: RMS/EPD&C FLIGHT: 2/1R
MDAC ID: 4346 ABORT: /NA

ITEM: SWITCH, S6
FAILURE MODE: FAILS OPEN

LEAD ANALYST: ROBINSON SUBSYS LEAD: SCHMECKPEPER

BREAKDOWN HIERARCHY:

- 1) RMS, 05-6IC
- 2) MANIPULATOR LATCH CONTROL
- 3) MRL LATCH/RELEASE SWITCH
- 4) SWITCH, TOGGLE
- 5) SWITCH, S6
- 6)
- 7)
- 8)
- 9)

CRITICALITIES

FLIGHT PHASE	HDW/FUNC	ABORT	HDW/FUNC
PRELAUNCH:	/NA	RTLS:	/NA
LIFTOFF:	/NA	TAL:	/NA
ONORBIT:	3/1R	AOA:	/NA
DEORBIT:	/NA	ATO:	/NA
LANDING/SAFING:	/NA		

REDUNDANCY SCREENS: A [1] B [P] C [P]

LOCATION: 36V73AKA2S6
PART NUMBER: MC452-0102-70203

CAUSES: MECHANICAL/STRUCTURAL MALFUNCTION, SHOCK, VIBRATION,
CORROSION, CONTAMINATION

EFFECTS/RATIONALE:

FAILURE WILL RESULT IN LOSS OF ABILITY TO DRIVE THE MRL CAUSING
POTENTIAL INABILITY TO RELEASE/RESTRAIN THE RMS.

SUBSEQUENT FAILURE OF MRL LATCHES AFTER RMS IS UNCRADLED COULD
REQUIRE JETTISON OF THE RMS.

POSSIBILITY FOR LOSS OF CREW/VEHICLE IF THE RMS CANNOT BE SAFELY
JETTISONED.

REFERENCES: VS72-956099, ROCKWELL ELECTRICAL SCHEMATIC, RMS
JSC-11174, SPACE SHUTTLE SYSTEMS HANDBOOK

INDEPENDENT ORBITER ASSESSMENT
ORBITER SUBSYSTEM ANALYSIS WORKSHEET

DATE: 2/17/88	HIGHEST CRITICALITY	HDW/FUNC
SUBSYSTEM: RMS/EPD&C	FLIGHT:	2/1R
MDAC ID: 4347	ABORT:	/NA

ITEM: SWITCH, S6
FAILURE MODE: FAILS CLOSED (ON)

LEAD ANALYST: ROBINSON SUBSYS LEAD: SCHMECKPEPER

BREAKDOWN HIERARCHY:

- 1) RMS, 05-6IC
- 2) MANIPULATOR LATCH CONTROL
- 3) MRL LATCH/RELEASE SWITCH
- 4) SWITCH, TOGGLE
- 5) SWITCH, S6
- 6)
- 7)
- 8)
- 9)

FLIGHT PHASE	CRITICALITIES		HDW/FUNC
	HDW/FUNC	ABORT	
PRELAUNCH:	/NA	RTLS:	/NA
LIFTOFF:	/NA	TAL:	/NA
ONORBIT:	3/1R	AOA:	/NA
DEORBIT:	/NA	ATO:	/NA
LANDING/SAFING:	/NA		

REDUNDANCY SCREENS: A [1] B [P] C [P]

LOCATION: 36V73AKA2S6
PART NUMBER: MC452-0102-70203

CAUSES: MECHANICAL/STRUCTURAL MALFUNCTION, SHOCK, VIBRATION,
CORROSION, CONTAMINATION

EFFECTS/RATIONALE:

FAILURE OF THE SWITCH IN A CLOSED CONDITION WILL RESULT IN CONTINUOUS UNCOMMANDED DRIVING OF THE MRL MOTORS. SUBSEQUENT COMMAND IN OPPOSITE DIRECTION OF FAILURE WILL ENABLE ALL MOTORS TO DRIVE LATCH/RELEASE SIMULTANEOUSLY WHEN MRL IS IN MID TRAVEL

AND POWER CIRCUIT BREAKERS WILL BE BLOWN. FAILURE WILL POSSIBLY RESULT IN LOSS OF MISSION DUE TO INABILITY TO RELEASE THE RMS OR RESTRAIN AS APPROPRIATE. FAILURE WILL REQUIRE JETTISON IF MRL LATCHES FAIL CLOSED AFTER RMS IS UNCRADELED. THERE IS A

POSSIBILITY FOR LOSS OF CREW/VEHICLE IF THE RMS CANNOT BE SAFELY JETTISONED.

REFERENCES: VS72-956099, ROCKWELL ELECTRICAL SCHEMATIC, RMS JSC-11174, SPACE SHUTTLE SYSTEMS HANDBOOK

INDEPENDENT ORBITER ASSESSMENT
ORBITER SUBSYSTEM ANALYSIS WORKSHEET

DATE: 2/17/88
 SUBSYSTEM: RMS/EPD&C
 MDAC ID: 4348

HIGHEST CRITICALITY
 FLIGHT: 3/3
 ABORT: /NA

ITEM: SWITCH, S6
 FAILURE MODE: PREMATURE OPEN

LEAD ANALYST: ROBINSON SUBSYS LEAD: SCHMECKPEPER

BREAKDOWN HIERARCHY:

- 1) RMS, 05-6IC
- 2) MANIPULATOR LATCH CONTROL
- 3) MRL LATCH/RELEASE SWITCH
- 4) SWITCH, TOGGLE
- 5) SWITCH, S6
- 6)
- 7)
- 8)
- 9)

FLIGHT PHASE	CRITICALITIES		
	HDW/FUNC	ABORT	HDW/FUNC
PRELAUNCH:	/NA	RTLS:	/NA
LIFTOFF:	/NA	TAL:	/NA
ONORBIT:	3/3	AOA:	/NA
DEORBIT:	/NA	ATO:	/NA
LANDING/SAFING:	/NA		

REDUNDANCY SCREENS: A [] B [] C []

LOCATION: 36V73AKA2S6
 PART NUMBER: MC452-0102-70203

CAUSES: MECHANICAL/STRUCTURAL MALFUNCTION, SHOCK, VIBRATION,
 CORROSION, CONTAMINATION

EFFECTS/RATIONALE:

FAILURE WILL RESULT IN INTERMITTENT OPERATION OF THE MRL DURING
 RELEASE OR LATCH OPERATION.

REFERENCES: VS72-956099, ROCKWELL ELECTRICAL SCHEMATIC, RMS
 JSC-11174, SPACE SHUTTLE SYSTEMS HANDBOOK

INDEPENDENT ORBITER ASSESSMENT
ORBITER SUBSYSTEM ANALYSIS WORKSHEET

DATE: 2/17/88 HIGHEST CRITICALITY HDW/FUNC
SUBSYSTEM: RMS/EPD&C FLIGHT: 2/1R
MDAC ID: 4349 ABORT: /NA

ITEM: SWITCH, S6
FAILURE MODE: PREMATURE CLOSE

LEAD ANALYST: ROBINSON SUBSYS LEAD: SCHMECKPEPER

BREAKDOWN HIERARCHY:

- 1) RMS, 05-6IC
- 2) MANIPULATOR LATCH CONTROL
- 3) MRL LATCH/RELEASE SWITCH
- 4) SWITCH, TOGGLE
- 5) SWITCH, S6
- 6)
- 7)
- 8)
- 9)

CRITICALITIES

FLIGHT PHASE	HDW/FUNC	ABORT	HDW/FUNC
PRELAUNCH:	/NA	RTLS:	/NA
LIFTOFF:	/NA	TAL:	/NA
ONORBIT:	3/1R	AOA:	/NA
DEORBIT:	/NA	ATO:	/NA
LANDING/SAFING:	/NA		

REDUNDANCY SCREENS: A [1] B [P] C [P]

LOCATION: 36V73AKA2S6
PART NUMBER: MC452-0102-70203

CAUSES: MECHANICAL/STRUCTURAL MALFUNCTION, SHOCK, VIBRATION,
CORROSION, CONTAMINATION

EFFECTS/RATIONALE:

PREMATURE CLOSE OF THIS SWITCH WILL ENABLE ALL OF THE MRL MOTORS TO DRIVE LATCH/RELEASE SIMULTANEOUSLY WHEN THE MRL IS IN MID TRAVEL.

SUBSEQUENT FAILURE OF PAYLOAD BAY MECHANICAL POWER SWITCH DURING ASCENT/ENTRY COULD CAUSE UNCOMMANDED UNLATCHING OF THE MRL. THIS COULD RESULT IN LOSS OF CREW/VEHICLE DUE TO UNRESTRAINED RMS MOTION.

POSSIBILITY FOR LOSS OF CREW/VEHICLE IF THE RMS CANNOT BE SAFELY JETTISONED.

REFERENCES: VS72-956099, ROCKWELL ELECTRICAL SCHEMATIC, RMS JSC-11174, SPACE SHUTTLE SYSTEMS HANDBOOK

INDEPENDENT ORBITER ASSESSMENT
ORBITER SUBSYSTEM ANALYSIS WORKSHEET

DATE: 2/17/88 HIGHEST CRITICALITY HDW/FUNC
SUBSYSTEM: RMS/EPD&C FLIGHT: 2/1R
MDAC ID: 4350 ABORT: /NA

ITEM: SWITCH, S6
FAILURE MODE: CONTACT TO CONTACT SHORT

LEAD ANALYST: ROBINSON SUBSYS LEAD: SCHMECKPEPER

BREAKDOWN HIERARCHY:

- 1) RMS, 05-6IC
- 2) MANIPULATOR LATCH CONTROL
- 3) MRL LATCH/RELEASE SWITCH
- 4) SWITCH, TOGGLE
- 5) SWITCH, S6
- 6)
- 7)
- 8)
- 9)

CRITICALITIES			
FLIGHT PHASE	HDW/FUNC	ABORT	HDW/FUNC
PRELAUNCH:	/NA	RTLS:	/NA
LIFTOFF:	/NA	TAL:	/NA
ONORBIT:	3/1R	AOA:	/NA
DEORBIT:	/NA	ATO:	/NA
LANDING/SAFING:	/NA		

REDUNDANCY SCREENS: A [1] B [P] C [P]

LOCATION: 36V73AKA2S6
PART NUMBER: MC452-0102-70203

CAUSES: MECHANICAL/STRUCTURAL MALFUNCTION, SHOCK, VIBRATION,
CORROSION, CONTAMINATION

EFFECTS/RATIONALE:

CONTACT TO CONTACT SHORT IN THE SWITCH WILL RESULT IN
CONTINUOUS UNCOMMANDED DRIVING OF THE MRL MOTORS. SUBSEQUENT
COMMAND IN OPPOSITE DIRECTION OF FAILURE WILL ENABLE ALL MOTORS
TO DRIVE LATCH/RELEASE SIMULTANEOUSLY WHEN MRL IS IN MID TRAVEL

AND POWER CIRCUIT BREAKERS WILL BE BLOWN. FAILURE WILL
POSSIBLY RESULT IN LOSS OF MISSION DUE TO INABILITY TO RELEASE
THE RMS OR RESTRAIN AS APPROPRIATE. FAILURE WILL REQUIRE
JETTISON IF MRL LATCHES FAIL CLOSED AFTER RMS IS UNCRADELED.
THERE IS A

POSSIBILITY FOR LOSS OF CREW/VEHICLE IF THE RMS CANNOT BE SAFELY
JETTISONED.

REFERENCES: VS72-956099, ROCKWELL ELECTRICAL SCHEMATIC, RMS
JSC-11174, SPACE SHUTTLE SYSTEMS HANDBOOK

INDEPENDENT ORBITER ASSESSMENT
ORBITER SUBSYSTEM ANALYSIS WORKSHEET

DATE: 2/17/88 HIGHEST CRITICALITY HDW/FUNC
SUBSYSTEM: RMS/EPD&C FLIGHT: 2/1R
MDAC ID: 4351 ABORT: /NA

ITEM: SWITCH, S6
FAILURE MODE: FAILS OPEN

LEAD ANALYST: ROBINSON SUBSYS LEAD: SCHMECKPEPER

BREAKDOWN HIERARCHY:

- 1) RMS, 05-6IC
- 2) MANIPULATOR LATCH CONTROL
- 3) MRL LATCH/RELEASE SWITCH
- 4) SWITCH, TOGGLE
- 5) SWITCH, S6
- 6)
- 7)
- 8)
- 9)

CRITICALITIES

FLIGHT PHASE	HDW/FUNC	ABORT	HDW/FUNC
PRELAUNCH:	/NA	RTLS:	/NA
LIFTOFF:	/NA	TAL:	/NA
ONORBIT:	3/1R	AOA:	/NA
DEORBIT:	/NA	ATO:	/NA
LANDING/SAFING:	/NA		

REDUNDANCY SCREENS: A [1] B [P] C [P]

LOCATION: 36V73AKA2S6
PART NUMBER: MC452-0102-70203

CAUSES: MECHANICAL/STRUCTURAL MALFUNCTION, SHOCK, VIBRATION,
CORROSION, CONTAMINATION

EFFECTS/RATIONALE:

FAILURE WILL RESULT IN LOSS OF ABILITY TO DRIVE THE MRL CAUSING
POTENTIAL INABILITY TO RELEASE/RESTRAIN THE RMS.

SUBSEQUENT FAILURE OF MRL LATCHES AFTER RMS IS UNCRADLED COULD
REQUIRE JETTISON OF THE RMS.

POSSIBILITY FOR LOSS OF CREW/VEHICLE IF THE RMS CANNOT BE SAFELY
JETTISONED.

REFERENCES: VS72-956099, ROCKWELL ELECTRICAL SCHEMATIC, RMS
JSC-11174, SPACE SHUTTLE SYSTEMS HANDBOOK

INDEPENDENT ORBITER ASSESSMENT
ORBITER SUBSYSTEM ANALYSIS WORKSHEET

DATE:	2/24/99	HIGHEST CRITICALITY	HDW/FUNC
SUBSYSTEM:	RMS/EPD&C	FLIGHT:	3/1R
MDAC ID:	4353	ABORT:	/NA

ITEM: LIMIT SWITCH - LATCHED & RELEASED
FAILURE MODE: FAILS OPEN.

LEAD ANALYST: ROBINSON SUBSYS LEAD: SCHMECKPEPER

BREAKDOWN HIERARCHY:

- 1) RMS, 05-6IC
- 2) MANIPULATOR LATCH CONTROL
- 3) LOGIC CONTROL CIRCUIT
- 4) POSITION MICROSWITCHES
- 5) LIMIT SWITCH - LATCHED & RELEASED
- 6)
- 7)
- 8)
- 9)

CRITICALITIES			
FLIGHT PHASE	HDW/FUNC	ABORT	HDW/FUNC
PRELAUNCH:	/NA	RTLS:	/NA
LIFTOFF:	/NA	TAL:	/NA
ONORBIT:	3/1R	AOA:	/NA
DEORBIT:	/NA	ATO:	/NA
LANDING/SAFING:	/NA		

REDUNDANCY SCREENS: A [1] B [P] C [P]

LOCATION:
PART NUMBER:

CAUSES: FAILURE/DEFLECTION OF INTERNAL PARTS, VIBRATION,
CONTAMINATION/FORIEGN OBJECT/DEBRIS

EFFECTS/RATIONALE:

FAILURE WILL RESULT IN ONE RELEASED MICROSWITCH INDICATING
PEDESTAL MRL NOT LATCHED OR RELEASED REGARDLESS OF THE ACTUAL
SITUATION.

FAILURE WILL ALLOW THE ASSOCIATED MOTOR DURING MRL OPERATIONS
UNTIL THE COMMAND IS REMOVED.

SUBSEQUENT FAILURE OF OTHER SWITCH COULD ULTIMATELY LEAD TO
MOTOR BURNOUT/STALL. FURTHER FAILURES COULD CAUSE REQUIREMENT TO
JETTISON AND POSSIBLY LOSS OF CREW/VEHICLE.

REFERENCES: VS72-956099, ROCKWELL ELECTRICAL SCHEMATIC, RMS
JSC-11174, SPACE SHUTTLE SYSTEMS HANDBOOK

INDEPENDENT ORBITER ASSESSMENT
ORBITER SUBSYSTEM ANALYSIS WORKSHEET

DATE: 2/24/99 HIGHEST CRITICALITY HDW/FUNC
SUBSYSTEM: RMS/EPD&C FLIGHT: 3/1R
MDAC ID: 4354 ABORT: /NA

ITEM: LIMIT SWITCH - RELEASE
FAILURE MODE: FAILS CLOSED

LEAD ANALYST: ROBINSON SUBSYS LEAD: SCHMECKPEPER

BREAKDOWN HIERARCHY:

- 1) RMS, 05-6IC
- 2) MANIPULATOR LATCH CONTROL
- 3) LOGIC CONTROL CIRCUIT
- 4) POSITION MICROSWITCHES
- 5) LIMIT SWITCH - RELEASE
- 6)
- 7)
- 8)
- 9)

CRITICALITIES			
FLIGHT PHASE	HDW/FUNC	ABORT	HDW/FUNC
PRELAUNCH:	/NA	RTLS:	/NA
LIFTOFF:	/NA	TAL:	/NA
ONORBIT:	3/2R	AOA:	/NA
DEORBIT:	/NA	ATO:	/NA
LANDING/SAFING:	/NA		

REDUNDANCY SCREENS: A [1] B [P] C [P]

LOCATION:
PART NUMBER:

CAUSES: FAILURE/DEFLECTION OF INTERNAL PARTS, VIBRATION,
CONTAMINATION/FORIEGN OBJECT/DEBRIS

EFFECTS/RATIONALE:

FAILURE WILL RESULT IN ONE RELEASED MICROSWITCH INDICATING
PEDESTAL MRL NOT LATCHED OR RELEASED REGARDLESS OF THE ACTUAL
SITUATION.

FAILURE WILL ALLOW THE ASSOCIATED MOTOR DURING MRL OPERATIONS
UNTIL THE COMMAND IS REMOVED.

SUBSEQUENT FAILURE WILL RESULT IN POSSIBLE LOSS OF MISSION DUE
TO LOSS OF ABILITY TO UNCRADLE THE RMS.

REFERENCES: VS72-956099, ROCKWELL ELECTRICAL SCHEMATIC, RMS
JSC-11174, SPACE SHUTTLE SYSTEMS HANDBOOK

INDEPENDENT ORBITER ASSESSMENT
ORBITER SUBSYSTEM ANALYSIS WORKSHEET

DATE: 2/24/99 HIGHEST CRITICALITY HDW/FUNC
SUBSYSTEM: RMS/EPD&C FLIGHT: 3/1R
MDAC ID: 4355 ABORT: /NA

ITEM: LIMIT SWITCH - LATCH
FAILURE MODE: FAILS CLOSED

LEAD ANALYST: ROBINSON SUBSYS LEAD: SCHMECKPEPER

BREAKDOWN HIERARCHY:

- 1) RMS, 05-6IC
- 2) MANIPULATOR LATCH CONTROL
- 3) LOGIC CONTROL CIRCUIT
- 4) POSITION MICROSWITCHES
- 5) LIMIT SWITCH - LATCHED & RELEASED
- 6)
- 7)
- 8)
- 9)

FLIGHT PHASE	CRITICALITIES		
	HDW/FUNC	ABORT	HDW/FUNC
PRELAUNCH:	/NA	RTLS:	/NA
LIFTOFF:	/NA	TAL:	/NA
ONORBIT:	3/1R	AOA:	/NA
DEORBIT:	/NA	ATO:	/NA
LANDING/SAFING:	/NA		

REDUNDANCY SCREENS: A [1] B [P] C [P]

LOCATION:
PART NUMBER:

CAUSES: FAILURE/DEFLECTION OF INTERNAL PARTS, VIBRATION,
CONTAMINATION/FORIEGN OBJECT/DEBRIS

EFFECTS/RATIONALE:

FAILURE WILL RESULT IN ONE RELEASED MICROSWITCH INDICATING
PEDESTAL MRL NOT LATCHED OR RELEASED REGARDLESS OF THE ACTUAL
SITUATION.

FAILURE WILL ALLOW THE ASSOCIATED MOTOR DURING MRL OPERATIONS
UNTIL THE COMMAND IS REMOVED.

SUBSEQUENT FAILURE OF OTHER SWITCH COULD ULTIMATELY LEAD TO
MOTOR BURNOUT/STALL. FURTHER FAILURES COULD CAUSE REQUIREMENT TO
JETTISON AND POSSIBLY LOSS OF CREW/VEHICLE.

REFERENCES: VS72-956099, ROCKWELL ELECTRICAL SCHEMATIC, RMS
JSC-11174, SPACE SHUTTLE SYSTEMS HANDBOOK

APPENDIX F

NASA FMEA TO IOA WORKSHEET CROSS REFERENCE/RECOMMENDATIONS

This section provides a cross reference between the NASA FMEA and corresponding IOA analysis worksheet(s) included in Appendix E. The Appendix F identifies: NASA FMEA Number, IOA Assessment Number, NASA criticality and redundancy screen data, and IOA recommendations. Appendix F Legend is as follows:

Code Definition

- | | |
|-----|--|
| 0 | No issue. |
| 1 | IOA concurs with NASA FMEA/CIL and recommends IOA generate a like FMEA. |
| 2 | IOA recommends that a NASA FMEA be generated for this failure mode for this component. |
| 3 | IOA concurs with NASA FMEA/CIL and recommends upgrading the IOA FMEA Crit. |
| 4 | IOA recommends upgrading the NASA FMEA Crit. |
| 5 | IOA concurs with NASA FMEA/CIL and recommends downgrading the IOA FMEA Crit. |
| 6 | IOA recommends downgrading the NASA FMEA Crit. |
| 7 | Correct the IOA FMEA redundancy screens. |
| 8. | Correct the NASA FMEA redundancy screens. |
| 9. | IOA recommends combining the IOA FMEA Failure Modes. |
| 10. | IOA recommends combining the NASA FMEA Failure Modes. |
| 11. | IOA recommends combining the IOA FMEA Components. |
| 12. | IOA recommends combining the NASA FMEA Components. |
| 13. | Correct typing error in FMEA. |
| 14. | Disregard this FMEA. |
| 15. | This FMEA is not a CIL item. |

EPD&C/RMS APPENDIX F (05-61A)
NASA FMEA TO IOA WORKSHEET CROSS REFERENCE/RECOMMENDATIONS

IDENTIFIERS		NASA			IOA			RECOMMENDATIONS		
NASA FMEA NUMBER	ASSESSMENT IOA NUMBER	CRIT HW/F	SCREENS			CRIT HW/F	SCREENS		RESOLUTION CODES	ISSUE
05-61A-2001-1	RMS-4031	3/3				2/2			0, 9, 11	
05-61A-2001-1	RMS-4032	3/3				2/1R	1 NA NA		2, 9, 11	
05-61A-2001-1	RMS-4033	3/3				3/3			0	
05-61A-2001-2	RMS-4051X	3/3				3/3			0, 1, 14, 15	
05-61A-2002-1	RMS-4018	3/1R	P	P	P	2/2			0, 5, 11	
05-61A-2002-1	RMS-4019	3/1R	P	P	P	2/1R	1 NA NA		4, 7	X
05-61A-2003-1	RMS-4016	1/1				2/2			0, 9, 11	
05-61A-2003-1	RMS-4017	1/1				2/1R	1 NA NA		0, 3	
05-61A-2004-1	RMS-4040	1/1				2/1R	1 NA NA		0, 3, 11	
05-61A-2004-1	RMS-4041	1/1				2/1R	1 NA NA		0, 3, 11	
05-61A-2006-1	RMS-4028	2/2				2/2			0, 11	
05-61A-2006-1	RMS-4029	2/2				2/1R	NA NA		2, 9, 11	X
05-61A-2006-2	RMS-4030	3/3				3/3			0, 15	
05-61A-2026-1	RMS-4010	2/1R	P	F	P	2/1R	P P		0, 7, 11	
05-61A-2026-1	RMS-4011	2/1R	P	F	P	2/1R	P P		0, 7, 11	
05-61A-2026-1	RMS-4013	2/1R	P	F	P	2/1R	P P		0, 7, 11	
05-61A-2026-1	RMS-4014	2/1R	P	F	P	2/1R	P P		0, 7, 11	
05-61A-2026-2	RMS-4012	3/1R	P	F	P	2/2			0, 3, 11	
05-61A-2026-2	RMS-4015	3/1R	P	F	P	2/2			0, 7, 11	
05-61A-2028-5	RMS-4002	1/1				1/1			0	
05-61A-2028-6	RMS-4006	2/1R	P	F	P	3/3			0, 3	

EPD&C/RMS APPENDIX F (05-61A Cont'd)
 NASA FMEA TO IOA WORKSHEET CROSS REFERENCE/RECOMMENDATIONS

IDENTIFIERS		NASA		IOA		RECOMMENDATIONS	
NASA FMEA NUMBER	ASSESSMENT IOA NUMBER	CRIT HW/F	SCREENS	CRIT HW/F	SCREENS	RESOLUTION CODES	ISSUE
05-61A-2028-9	RMS-4049X	1/1		1/1		0, 1	
05-61A-2028-X	RMS-4001	/		2/2		2	X
05-61A-2028-X	RMS-4003	/		2/2		2	X
05-61A-2028-X	RMS-4004	/		2/2		2	X
05-61A-2028-X	RMS-4005	/		2/1R	1 NA NA	2	X
05-61A-2029-5	RMS-4007	2/1R	P F P	2/2		0, 3	
05-61A-2029-5	RMS-4008	1/1		1/1		0	
05-61A-2029-5	RMS-4009	1/1		1/1		0	
05-61A-2076-1	RMS-4020	2/1R	P F P	3/2R	P P	0, 3, 7, 11	
05-61A-2076-1	RMS-4021	2/1R	P F P	3/2R	P P	0, 3, 7, 11	
05-61A-2076-1	RMS-4022	2/1R	P F P	3/2R	P P	0, 3, 7, 11	
05-61A-2076-1	RMS-4023	2/1R	P F P	3/2R	P P	0, 3, 7, 11	
05-61A-2076-2	RMS-4050X	3/3		3/3		0, 1, 14, 15	
05-61A-2078-1	RMS-4024	3/3		3/3		0, 11, 15	
05-61A-2078-1	RMS-4025	3/3		3/3		0, 11, 15	
05-61A-2078-1	RMS-4026	3/3		3/3		0, 11, 15	
05-61A-2078-1	RMS-4027	3/3		3/3		0, 11, 15	
05-61A-2126-1	RMS-4034	1/1		2/2		0, 3, 9, 11	
05-61A-2126-1	RMS-4035	1/1		2/1R	1 NA NA	0, 3, 9, 11	
05-61A-2126-1	RMS-4037	1/1		2/2		0, 3, 9, 11	
05-61A-2126-1	RMS-4038	1/1		2/1R	1 P P	0, 3, 9, 11	

EPD&C/RMS APPENDIX F (05-61A Concluded)
 NASA FMEA TO IOA WORKSHEET CROSS REFERENCE/RECOMMENDATIONS

IDENTIFIERS		NASA			IOA			RECOMMENDATIONS		
NASA FMEA NUMBER	ASSESSMENT IOA NUMBER	CRIT HW/F	SCREENS			CRIT HW/F	SCREENS		RESOLUTION CODES	ISSUE
05-61A-2126-2	RMS-4036	2/1R	P	F	P	3/3			0, 3, 11	
05-61A-2126-2	RMS-4039	2/1R	P	F	P	3/3			0, 3, 11	
05-61A-2176-1	RMS-4042	2/1R	P	F	P	3/2R	P	P	0, 3, 11	
05-61A-2176-1	RMS-4043	2/1R	P	F	P	3/2R	P	P	0, 3, 11	
05-61A-2176-1	RMS-4047	2/1R	P	F	P	3/2R	P	P	0, 3, 11	
05-61A-2176-1	RMS-4048	2/1R	P	F	P	3/2R	P	P	0, 3, 11	
05-61A-2176-2	RMS-4053X	3/1R	P	F	P	3/1R	P	F	0, 1	
05-61A-2178-1	RMS-4044	1/1				2/2			0, 3	
05-61A-2178-2	RMS-4052X	3/3				3/3			0, 1, 14, 15	
05-61A-2179-1	RMS-4045	3/1R	P	P	P	2/1R	1	NA NA	4, 11	X
05-61A-2179-1	RMS-4046	3/1R	P	P	P	2/1R	1	NA NA	4, 11	X
05-61A-2179-2	RMS-4054X	2/1R	P	F	P	2/1R	1	F P	0, 1	

EPD&C/RMS APPENDIX F (05-61B)
NASA FMEA TO IOA WORKSHEET CROSS REFERENCE/RECOMMENDATIONS

IDENTIFIERS		NASA			IOA			RECOMMENDATIONS		
NASA FMEA NUMBER	ASSESSMENT IOA NUMBER	CRIT HW/F	SCREENS			CRIT HW/F	SCREENS		RESOLUTION CODES	ISSUE
05-61B-MPM-1	RMS-4109	3/1R	P	P	P	3/2R	P	P	0, 3, 11	
05-61B-MPM-1	RMS-4110	3/1R	P	P	P	3/2R	P	P	0, 3, 11	
05-61B-MPM-1	RMS-4111	3/1R	P	P	P	3/2R	P	P	0, 3, 11	
05-61B-MPM-1	RMS-4112	3/1R	P	P	P	3/2R	P	P	0, 3, 11	
05-61B-MPM-2A	RMS-4105	2/1R	P	P	P	2/2			0, 3, 11	
05-61B-MPM-2A	RMS-4107	2/1R	P	P	P	2/2			0, 3, 11	
05-61B-MPM-2B	RMS-4106	1/1	P	P	P	1/1			0, 10, 12	
05-61B-MPM-2B	RMS-4108A	1/1	P	P	P	1/1			0, 10, 12	
05-61B-MPM-2B, D,	RMS-4108	1/1	P	P	P	1/1			0, 10, 12	
05-61B-MPM-2C	RMS-4175X	3/3	P	P	P	3/3			0, 1, 8, 15	
05-61B-MPM-2D	RMS-4108B	1/1	P	P	P	1/1			0, 10, 12	
05-61B-MPM-2E	RMS-4108C	1/1	P	P	P	1/1			0, 10, 12	
05-61B-MPM-2F	RMS-4176X	2/1R	P	P	P	2/1R	1	P	P	0, 1
05-61B-MPM-2G	RMS-4108D	1/1	P	P	P	1/1			0, 10, 12	
05-61B-MPM-4	RMS-4113	3/1R	P	P	P	3/2R	P	P	0, 3, 9, 11	
05-61B-MPM-4	RMS-4115	3/1R	P	P	P	3/2R	P	P	0, 3, 9, 11	
05-61B-MPM-4	RMS-4117	3/1R	P	P	P	3/2R	P	P	0, 3, 9, 11	
05-61B-MPM-4	RMS-4119	3/1R	P	P	P	3/2R	P	P	0, 3, 9, 11	
05-61B-MPM-4	RMS-4121	3/1R	P	P	P	3/2R	P	P	0, 3, 9, 11	
05-61B-MPM-4	RMS-4123	3/1R	P	P	P	3/2R	P	P	0, 3, 9, 11	
05-61B-MPM-4	RMS-4125	3/1R	P	P	P	3/2R	P	P	0, 3, 9, 11	

EPD&C/RMS APPENDIX F (05-61B Cont'd)
 NASA FMEA TO IOA WORKSHEET CROSS REFERENCE/RECOMMENDATIONS

IDENTIFIERS		NASA			IOA			RECOMMENDATIONS		
NASA FMEA NUMBER	ASSESSMENT IOA NUMBER	CRIT HW/F	SCREENS			CRIT HW/F	SCREENS		RESOLUTION CODES	ISSUE
05-61B-MPM-4	RMS-4127	3/1R	P	P	P	3/2R	P	P	0, 3, 9, 11	
05-61B-MPM-5	RMS-4114	1/1	N	N	N	1/1			0, 11	
05-61B-MPM-5	RMS-4116	1/1	N	N	N	1/1			0, 11	
05-61B-MPM-5	RMS-4118	1/1	N	N	N	1/1			0, 11	
05-61B-MPM-5	RMS-4120	1/1	N	N	N	1/1			0, 11	
05-61B-MPM-5	RMS-4122	1/1	N	N	N	1/1			0, 11	
05-61B-MPM-5	RMS-4124	1/1	N	N	N	1/1			0, 11	
05-61B-MPM-5	RMS-4126	1/1	N	N	N	1/1			0, 11	
05-61B-MPM-5	RMS-4128	1/1	N	N	N	1/1			0, 11	
05-61B-MPM-5A	RMS-4177X	3/3				3/3			0, 1, 8, 15	
05-61B-MPM-6	RMS-4178X	3/1R	P	P	P	3/1R	1	P P	0, 1	
05-61B-MPM-7	RMS-4179X	3/1R	P	P	P	3/1R	1	P P	0, 1	
05-61B-MPM-7A	RMS-4180X	3/1R	P	P	P	3/2R	1	P P	0, 1	
05-61B-MPM-8	RMS-4181X	3/1R	P	P	P	3/1R	1	P P	0, 1	
05-61B-MPM-8A	RMS-4182X	3/1R	P	P	P	3/1R	1	P P	0, 1	
05-61B-MPM-10	RMS-4129	3/3	N	N	N	3/3			0, 11, 15	
05-61B-MPM-10	RMS-4130	3/3	N	N	N	3/3			0, 11, 15	
05-61B-MPM-10	RMS-4131	3/3	N	N	N	3/3			0, 11, 15	
05-61B-MPM-10	RMS-4132	3/3	N	N	N	3/3			0, 11, 15	
05-61B-MPM-10	RMS-4133	3/3	N	N	N	3/3			0, 11, 15	
05-61B-MPM-10	RMS-4134	3/3	N	N	N	3/3			0, 11, 15	

EPD&C/RMS APPENDIX F (05-6IB Cont'd)
 NASA FMEA TO IOA WORKSHEET CROSS REFERENCE/RECOMMENDATIONS

IDENTIFIERS		NASA			IOA		RECOMMENDATIONS		
NASA FMEA NUMBER	ASSESSMENT IOA NUMBER	CRIT HW/F	SCREENS			CRIT HW/F	SCREENS	RESOLUTION CODES	ISSUE
05-6IB-MPM-10	RMS-4135	3/3	N	N	N	3/3		0, 11, 15	
05-6IB-MPM-10	RMS-4136	3/3	N	N	N	3/3		0, 11, 15	
05-6IB-MPM-10	RMS-4137	3/3	N	N	N	3/3		0, 11, 15	
05-6IB-MPM-10	RMS-4138	3/3	N	N	N	3/3		0, 11, 15	
05-6IB-MPM-10	RMS-4139	3/3	N	N	N	3/3		0, 11, 15	
05-6IB-MPM-10	RMS-4140	3/3	N	N	N	3/3		0, 11, 15	
05-6IB-MPM-10	RMS-4141	3/3	N	N	N	3/3		0, 11, 15	
05-6IB-MPM-10	RMS-4142	3/3	N	N	N	3/3		0, 11, 15	
05-6IB-MPM-10	RMS-4143	3/3	N	N	N	3/3		0, 11, 15	
05-6IB-MPM-10	RMS-4144	3/3	N	N	N	3/3		0, 11, 15	
05-6IB-MPM-11	RMS-4183X	3/3	N	N	N	3/3		0, 1, 15	

EPD&C/RMS APPENDIX F (05-61B Cont'd)
 NASA FMEA TO IOA WORKSHEET CROSS REFERENCE/RECOMMENDATIONS

IDENTIFIERS		NASA		IOA		RECOMMENDATIONS	
NASA FMEA NUMBER	ASSESSMENT IOA NUMBER	CRIT HW/F	SCREENS	CRIT HW/F	SCREENS	RESOLUTION CODES	ISSUE
REFER TO EPD&C BASIC FOR THE FOLLOWING FMEAS							
EPD&C 05-6-2613-1	RMS-4153	/		3/2R	NA NA	14	
EPD&C 05-6-2613-1	RMS-4155	/		3/2R	NA NA	14	
EPD&C 05-6-2613-2	RMS-4154	/		3/3		14	
EPD&C 05-6-2613-2	RMS-4156	/		3/3		14	
EPD&C 05-6-2614-1	RMS-4151	/		3/2R	NA NA	14	
EPD&C 05-6-2614-2	RMS-4152	/		3/3		14	
EPD&C 05-6-2615-1	RMS-4147	/		3/2R	NA NA	14	
EPD&C 05-6-2615-1	RMS-4149	/		3/2R	NA NA	14	
EPD&C 05-6-2615-2	RMS-4148	/		3/3		14	
EPD&C 05-6-2615-2	RMS-4150	/		3/3		14	
EPD&C 05-6-2616-1	RMS-4145	/		3/2R	NA NA	14	
EPD&C 05-6-2616-2	RMS-4146	/		3/3		14	
EPD&C 05-6-2653-1	RMS-4159	/		3/2R	NA NA	14	
EPD&C 05-6-2653-1	RMS-4167	/		3/2R	NA NA	14	
EPD&C 05-6-2653-2	RMS-4157	/		3/2R	NA NA	14	
EPD&C 05-6-2653-2	RMS-4161	/		3/2R	NA NA	14	
EPD&C 05-6-2653-2	RMS-4163	/		3/2R	NA NA	14	
EPD&C 05-6-2653-2	RMS-4165	/		3/2R	NA NA	14	
EPD&C 05-6-2653-2	RMS-4166	/		3/3		14	
EPD&C 05-6-2653-2	RMS-4168	/		3/3		14	
EPD&C 05-6-2654-1	RMS-4160	/		3/3		14	

EPD&C/RMS APPENDIX F (05-61B Concluded)
 NASA FMEA TO IOA WORKSHEET CROSS REFERENCE/RECOMMENDATIONS

IDENTIFIERS		NASA		IOA		RECOMMENDATIONS	
NASA FMEA NUMBER	ASSESSMENT IOA NUMBER	CRIT HW/F	SCREENS	CRIT HW/F	SCREENS	RESOLUTION CODES	ISSUE
EPD&C 05-6-2653-2	RMS-4163	/		3/2R	NA NA	14	
EPD&C 05-6-2653-2	RMS-4165	/		3/2R	NA NA	14	
EPD&C 05-6-2653-2	RMS-4166	/		3/3		14	
EPD&C 05-6-2653-2	RMS-4168	/		3/3		14	
EPD&C 05-6-2654-1	RMS-4160	/		3/3		14	
EPD&C 05-6-2655-1	RMS-4162	/		3/3		14	
EPD&C 05-6-2655-1	RMS-4164	/		3/3		14	
EPD&C 05-6-2656-1	RMS-4158	/		3/3		14	
EPD&C 05-6-2658-1	RMS-4101	/		2/1R	1 P P	14	
EPD&C 05-6-2658-1	RMS-4103	/		2/1R	1 P P	14	
EPD&C 05-6-2658-2	RMS-4102	/		3/3		14	
EPD&C 05-6-2658-2	RMS-4104	/		3/3		14	
EPD&C 05-6-2703-1	RMS-4172	/		3/2R	NA NA	14	
EPD&C 05-6-2703-1	RMS-4174	/		3/2R	NA NA	14	
EPD&C 05-6-2704-1	RMS-4170	/		3/2R	NA NA	14	
EPD&C 05-6-2705-1	RMS-4171	/		3/2R	NA NA	14	
EPD&C 05-6-2705-1	RMS-4173	/		3/2R	NA NA	14	
EPD&C 05-6-2706-1	RMS-4169	/		3/2R	NA NA	14	

EPD&C/RMS APPENDIX F (05-61C)
 NASA FMEA TO IOA WORKSHEET CROSS REFERENCE/RECOMMENDATIONS

IDENTIFIERS		NASA			IOA			RECOMMENDATIONS		
NASA FMEA NUMBER	ASSESSMENT IOA NUMBER	CRIT HW/F	SCREENS			CRIT HW/F	SCREENS		RESOLUTION CODES	ISSUE
05-61C-MRL-1	RMS-4345X	3/1R	P	P	P	3/1R	1	P P	0, 1	
05-61C-MRL-2A	RMS-4346X	2/1R	P	P	P	2/1R	1	P P	0, 1, 10	
05-61C-MRL-2B	RMS-4349X	2/1R	P	P	P	2/1R	1	P P	0, 1, 10	
05-61C-MRL-2C	RMS-4352X	3/3	P	P	P	3/3			0, 1, 15	
05-61C-MRL-2D	RMS-4350X	2/1R	P	P	P	2/1R	1	P P	0, 1, 10	
05-61C-MRL-2E	RMS-4347X	2/1R	P	P	P	2/1R	1	P P	0, 1, 10	
05-61C-MRL-2F	RMS-4348X	2/1R	P	P	P	2/1R	1	P P	0, 1, 10	
05-61C-MRL-2G	RMS-4351X	2/1R	P	P	P	2/1R	1	P P	0, 1, 10	
05-61C-MRL-4	RMS-4201	3/1R	P	P	P	3/2R		NA NA	0, 3, 7, 9, 11 1	
05-61C-MRL-4	RMS-4203	3/1R	P	P	P	3/2R		NA NA	0, 3, 7, 9, 11 1	
05-61C-MRL-4	RMS-4205	3/1R	P	P	P	3/2R		NA NA	0, 3, 7, 9, 11 1	
05-61C-MRL-4	RMS-4207	3/1R	P	P	P	3/2R		NA NA	0, 3, 7, 9, 11 1	
05-61C-MRL-4	RMS-4235	3/1R	P	P	P	3/2R		NA NA	0, 3, 7, 9, 11 1	
05-61C-MRL-4	RMS-4237	3/1R	P	P	P	3/2R		NA NA	0, 3, 7, 9, 11 1	
05-61C-MRL-4	RMS-4239	3/1R	P	P	P	3/2R		NA NA	0, 3, 7, 9, 11 1	
05-61C-MRL-4	RMS-4241	3/1R	P	P	P	3/2R		NA NA	0, 3, 7, 9, 11 1	
05-61C-MRL-4	RMS-4257	3/1R	P	P	P	3/2R		NA NA	0, 3, 7, 9, 11 1	
05-61C-MRL-4	RMS-4259	3/1R	P	P	P	3/2R		NA NA	0, 3, 7, 9, 11 1	
05-61C-MRL-4	RMS-4261	3/1R	P	P	P	3/2R		NA NA	0, 3, 7, 9, 11 1	
05-61C-MRL-4	RMS-4263	3/1R	P	P	P	3/2R		NA NA	0, 3, 7, 9, 11 1	
05-61C-MRL-4	RMS-4279	3/1R	P	P	P	3/2R		NA NA	0, 3, 7, 9, 11 1	

EPD&C/RMS APPENDIX F (05-61C Cont'd)
 NASA FMEA TO IOA WORKSHEET CROSS REFERENCE/RECOMMENDATIONS

IDENTIFIERS		NASA			IOA		RECOMMENDATIONS			
NASA FMEA NUMBER	ASSESSMENT IOA NUMBER	CRIT HW/F	SCREENS			CRIT HW/F	SCREENS		RESOLUTION CODES	ISSUE
05-61C-MRL-4	RMS-4281	3/1R	P	P	P	3/2R	NA	NA	0, 3, 7, 9, 11	1
05-61C-MRL-4	RMS-4283	3/1R	P	P	P	3/2R	NA	NA	0, 3, 7, 9, 11	1
05-61C-MRL-4	RMS-4285	3/1R	P	P	P	3/2R	NA	NA	0, 3, 7, 9, 11	1
05-61C-MRL-4	RMS-4301	3/1R	P	P	P	3/2R	NA	NA	0, 3, 7, 9, 11	1
05-61C-MRL-4	RMS-4303	3/1R	P	P	P	3/2R	NA	NA	0, 3, 7, 9, 11	1
05-61C-MRL-4	RMS-4305	3/1R	P	P	P	3/2R	NA	NA	0, 3, 7, 9, 11	1
05-61C-MRL-4	RMS-4307	3/1R	P	P	P	3/2R	NA	NA	0, 3, 7, 9, 11	1
05-61C-MRL-4	RMS-4323	3/1R	P	P	P	3/2R	NA	NA	0, 3, 7, 9, 11	1
05-61C-MRL-4	RMS-4325	3/1R	P	P	P	3/2R	NA	NA	0, 3, 7, 9, 11	1
05-61C-MRL-4	RMS-4327	3/1R	P	P	P	3/2R	NA	NA	0, 3, 7, 9, 11	1
05-61C-MRL-4	RMS-4329	3/1R	P	P	P	3/2R	NA	NA	0, 3, 7, 9, 11	1
05-61C-MRL-5	RMS-4202	3/1R	P	P	P	3/2R	NA	NA	0, 3, 7, 9, 11	1
05-61C-MRL-5	RMS-4204	3/1R	P	P	P	3/2R	NA	NA	0, 3, 7, 9, 11	1
05-61C-MRL-5	RMS-4236	3/1R	P	P	P	3/2R	NA	NA	0, 3, 7, 9, 11	1
05-61C-MRL-5	RMS-4238	3/1R	P	P	P	3/2R	NA	NA	0, 3, 7, 9, 11	1
05-61C-MRL-5	RMS-4258	3/1R	P	P	P	3/2R	NA	NA	0, 3, 7, 9, 11	1
05-61C-MRL-5	RMS-4260	3/1R	P	P	P	3/2R	NA	NA	0, 3, 7, 9, 11	1
05-61C-MRL-5	RMS-4280	3/1R	P	P	P	3/2R	NA	NA	0, 3, 7, 9, 11	1
05-61C-MRL-5	RMS-4282	3/1R	P	P	P	3/2R	NA	NA	0, 3, 7, 9, 11	1
05-61C-MRL-5	RMS-4302	3/1R	P	P	P	3/2R	NA	NA	0, 3, 7, 9, 11	1
05-61C-MRL-5	RMS-4304	3/1R	P	P	P	3/2R	NA	NA	0, 3, 7, 9, 11	1

EPD&C/RMS APPENDIX F (05-61C Cont'd)
NASA FMEA TO IOA WORKSHEET CROSS REFERENCE/RECOMMENDATIONS

IDENTIFIERS		NASA			IOA		RECOMMENDATIONS		
NASA FMEA NUMBER	ASSESSMENT IOA NUMBER	CRIT HW/F	SCREENS			CRIT HW/F	SCREENS	RESOLUTION CODES	ISSUE
05-61C-MRL-5	RMS-4324	3/1R	P	P	P	3/2R	NA NA	0, 3, 7, 9, 11	1
05-61C-MRL-5	RMS-4326	3/1R	P	P	P	3/2R	NA NA	0, 3, 7, 9, 11	1
05-61C-MRL-6	RMS-4206	2/1R	P	F	P	3/2R	NA NA	0, 3, 7, 9, 11	
05-61C-MRL-6	RMS-4208	2/1R	P	F	P	3/2R	NA NA	0, 3, 7, 9, 11	
05-61C-MRL-6	RMS-4240	2/1R	P	F	P	3/2R	NA NA	0, 3, 7, 9, 11	
05-61C-MRL-6	RMS-4242	2/1R	P	F	P	3/2R	NA NA	0, 3, 7, 9, 11	
05-61C-MRL-6	RMS-4262	2/1R	P	F	P	3/2R	NA NA	0, 3, 7, 9, 11	
05-61C-MRL-6	RMS-4264	2/1R	P	F	P	3/2R	NA NA	0, 3, 7, 9, 11	
05-61C-MRL-6	RMS-4284	2/1R	P	F	P	3/2R	NA NA	0, 3, 7, 9, 11	
05-61C-MRL-6	RMS-4286	2/1R	P	F	P	3/2R	NA NA	0, 3, 7, 9, 11	
05-61C-MRL-6	RMS-4306	2/1R	P	F	P	3/2R	NA NA	0, 3, 7, 9, 11	
05-61C-MRL-6	RMS-4308	2/1R	P	F	P	3/2R	NA NA	0, 3, 7, 9, 11	
05-61C-MRL-6	RMS-4328	2/1R	P	F	P	3/2R	NA NA	0, 3, 7, 9, 11	
05-61C-MRL-6	RMS-4330	2/1R	P	F	P	3/2R	NA NA	0, 3, 7, 9, 11	
05-61C-MRL-7	RMS-4217	3/1R	P	P	P	3/3		0, 3, 7, 9, 11	
05-61C-MRL-7	RMS-4218	3/1R	P	P	P	3/3		0, 3, 7, 9, 11	
05-61C-MRL-7	RMS-4251	3/1R	P	P	P	3/2R	NA NA	0, 3, 7, 9, 11	
05-61C-MRL-7	RMS-4252	3/1R	P	P	P	3/2R	NA NA	0, 3, 7, 9, 11	
05-61C-MRL-7	RMS-4273	3/1R	P	P	P	3/2R	NA NA	0, 3, 7, 9, 11	
05-61C-MRL-7	RMS-4274	3/1R	P	P	P	3/2R	NA NA	0, 3, 7, 9, 11	
05-61C-MRL-7	RMS-4295	3/1R	P	P	P	3/2R	NA NA	0, 3, 7, 9, 11	

EPD&C/RMS APPENDIX F (05-61C Cont'd)
 NASA FMEA TO IOA WORKSHEET CROSS REFERENCE/RECOMMENDATIONS

IDENTIFIERS		NASA			IOA			RECOMMENDATIONS		
NASA FMEA NUMBER	ASSESSMENT IOA NUMBER	CRIT HW/F	SCREENS			CRIT HW/F	SCREENS		RESOLUTION CODES	ISSUE
05-61C-MRL-7	RMS-4296	3/1R	P	P	P	3/2R	NA	NA	0, 3, 7, 9, 11	
05-61C-MRL-7	RMS-4317	3/1R	P	P	P	3/2R	NA	NA	0, 3, 7, 9, 11	
05-61C-MRL-7	RMS-4318	3/1R	P	P	P	3/2R	NA	NA	0, 3, 7, 9, 11	
05-61C-MRL-7	RMS-4339	3/1R	P	P	P	3/2R	NA	NA	0, 3, 7, 9, 11	
05-61C-MRL-7	RMS-4340	3/1R	P	P	P	3/2R	NA	NA	0, 3, 7, 9, 11	
05-61C-MRL-7A	RMS-4211	3/1R	P	P	P	3/3			0, 3, 7, 9, 11	
05-61C-MRL-7A	RMS-4212	3/1R	P	P	P	3/3			0, 3, 7, 9, 11	
05-61C-MRL-7A	RMS-4245	3/1R	P	P	P	3/3			0, 3, 7, 9, 11	
05-61C-MRL-7A	RMS-4246	3/1R	P	P	P	3/3			0, 3, 7, 9, 11	
05-61C-MRL-7A	RMS-4267	3/1R	P	P	P	3/3			0, 3, 7, 9, 11	
05-61C-MRL-7A	RMS-4268	3/1R	P	P	P	3/3			0, 3, 7, 9, 11	
05-61C-MRL-7A	RMS-4289	3/1R	P	P	P	3/3			0, 3, 7, 9, 11	
05-61C-MRL-7A	RMS-4290	3/1R	P	P	P	3/3			0, 3, 7, 9, 11	
05-61C-MRL-7A	RMS-4311	3/1R	P	P	P	3/3			0, 3, 7, 9, 11	
05-61C-MRL-7A	RMS-4312	3/1R	P	P	P	3/3			0, 3, 7, 9, 11	
05-61C-MRL-7A	RMS-4333	3/1R	P	P	P	3/3			0, 3, 7, 9, 11	
05-61C-MRL-7A	RMS-4334	3/1R	P	P	P	3/3			0, 3, 7, 9, 11	
05-61C-MRL-8	RMS-4628	3/1R	P	P	P	3/1R	1	P P	0, 1	
05-61C-MRL-9	RMS-4429	3/2R	P	P	P	3/1R	1	P P	0, 1	
05-61C-MRL-10	RMS-4630	3/1R	P	P	P	3/1R	1	P P	0, 1	
05-61C-MRL-11	RMS-4219	3/3	N	N	N	3/3			0, 9, 11, 15	

EPD&C/RMS APPENDIX F (05-61C Cont'd)
 NASA FMEA TO IOA WORKSHEET CROSS REFERENCE/RECOMMENDATIONS

IDENTIFIERS		NASA		IOA		RECOMMENDATIONS	
NASA FMEA NUMBER	ASSESSMENT IOA NUMBER	CRIT HW/F	SCREENS	CRIT HW/F	SCREENS	RESOLUTION CODES	ISSUE
05-61C-MRL-11	RMS-4220	3/3		3/3		0, 9, 11, 15	
05-61C-MRL-11	RMS-4221	3/3		3/3		0, 9, 11, 15	
05-61C-MRL-11	RMS-4222	3/3		3/3		0, 9, 11, 15	
05-61C-MRL-11	RMS-4223	3/3		3/3		0, 9, 11, 15	
05-61C-MRL-11	RMS-4224	3/3		3/3		0, 9, 11, 15	
05-61C-MRL-11	RMS-4225	3/3		3/3		0, 9, 11, 15	
05-61C-MRL-11	RMS-4226	3/3		3/3		0, 9, 11, 15	
05-61C-MRL-11	RMS-4227	3/3		3/3		0, 9, 11, 15	
05-61C-MRL-11	RMS-4228	3/3		3/3		0, 9, 11, 15	
05-61C-MRL-11	RMS-4229	3/3		3/3		0, 9, 11, 15	
05-61C-MRL-11	RMS-4230	3/3		3/3		0, 9, 11, 15	
05-61C-MRL-11	RMS-4231	3/3		3/3		0, 9, 11, 15	
05-61C-MRL-11	RMS-4232	3/3		3/3		0, 9, 11, 15	
05-61C-MRL-11	RMS-4233	3/3		3/3		0, 9, 11, 15	
05-61C-MRL-11	RMS-4234	3/3		3/3		0, 9, 11, 15	
05-61C-MRL-11	RMS-4253	3/3		3/3		0, 9, 11, 15	
05-61C-MRL-11	RMS-4254	3/3		3/3		0, 9, 11, 15	
05-61C-MRL-11	RMS-4255	3/3		3/3		0, 9, 11, 15	
05-61C-MRL-11	RMS-4256	3/3		3/3		0, 9, 11, 15	
05-61C-MRL-11	RMS-4275	3/3		3/3		0, 9, 11, 15	
05-61C-MRL-11	RMS-4276	3/3		3/3		0, 9, 11, 15	

EPD&C/RMS APPENDIX F (05-61C Cont'd)
 NASA FMEA TO IOA WORKSHEET CROSS REFERENCE/RECOMMENDATIONS

IDENTIFIERS		NASA			IOA		RECOMMENDATIONS		
NASA FMEA NUMBER	ASSESSMENT IOA NUMBER	CRIT HW/F	SCREENS			CRIT HW/F	RESOLUTION CODES		ISSUE
05-61C-MRL-11	RMS-4277	3/3				3/3	0, 9, 11, 15		
05-61C-MRL-11	RMS-4278	3/3				3/3	0, 9, 11, 15		
05-61C-MRL-11	RMS-4297	3/3				3/3	0, 9, 11, 15		
05-61C-MRL-11	RMS-4298	3/3				3/3	0, 9, 11, 15		
05-61C-MRL-11	RMS-4299	3/3				3/3	0, 9, 11, 15		
05-61C-MRL-11	RMS-4300	3/3				3/3	0, 9, 11, 15		
05-61C-MRL-11	RMS-4319	3/3				3/3	0, 9, 11, 15		
05-61C-MRL-11	RMS-4320	3/3				3/3	0, 9, 11, 15		
05-61C-MRL-11	RMS-4321	3/3				3/3	0, 9, 11, 15		
05-61C-MRL-11	RMS-4322	3/3				3/3	0, 9, 11, 15		
05-61C-MRL-11	RMS-4341	3/3				3/3	0, 9, 11, 15		
05-61C-MRL-11	RMS-4342	3/3				3/3	0, 9, 11, 15		
05-61C-MRL-11	RMS-4343	3/3				3/3	0, 9, 11, 15		
05-61C-MRL-11	RMS-4344	3/3				3/3	0, 9, 11, 15		
05-61C-MRL-12	RMS-4213	3/3	N	N	N	3/3	0, 9, 11, 15		
05-61C-MRL-12	RMS-4214	3/3	N	N	N	3/3	0, 9, 11, 15		
05-61C-MRL-12	RMS-4215	3/3	N	N	N	3/3	0, 9, 11, 15		
05-61C-MRL-12	RMS-4216	3/3	N	N	N	3/3	0, 9, 11, 15		
05-61C-MRL-12	RMS-4247	3/3	N	N	N	3/3	0, 9, 11, 15		
05-61C-MRL-12	RMS-4248	3/3	N	N	N	3/3	0, 9, 11, 15		
05-61C-MRL-12	RMS-4249	3/3	N	N	N	3/3	0, 9, 11, 15		

EPD&C/RMS APPENDIX F (05-61C Concluded)
 NASA FMEA TO IOA WORKSHEET CROSS REFERENCE/RECOMMENDATIONS

IDENTIFIERS		NASA			IOA		RECOMMENDATIONS		
NASA FMEA NUMBER	ASSESSMENT IOA NUMBER	CRIT HW/F	SCREENS			CRIT HW/F	SCREENS	RESOLUTION CODES	ISSUE
05-61C-MRL-12	RMS-4250	3/3	N	N	N	3/3		0, 9, 11, 15	
05-61C-MRL-12	RMS-4269	3/3	N	N	N	3/3		0, 9, 11, 15	
05-61C-MRL-12	RMS-4270	3/3	N	N	N	3/3		0, 9, 11, 15	
05-61C-MRL-12	RMS-4271	3/3	N	N	N	3/3		0, 9, 11, 15	
05-61C-MRL-12	RMS-4272	3/3	N	N	N	3/3		0, 9, 11, 15	
05-61C-MRL-12	RMS-4291	3/3	N	N	N	3/3		0, 9, 11, 15	
05-61C-MRL-12	RMS-4292	3/3	N	N	N	3/3		0, 9, 11, 15	
05-61C-MRL-12	RMS-4293	3/3	N	N	N	3/3		0, 9, 11, 15	
05-61C-MRL-12	RMS-4294	3/3	N	N	N	3/3		0, 9, 11, 15	
05-61C-MRL-12	RMS-4313	3/3	N	N	N	3/3		0, 9, 11, 15	
05-61C-MRL-12	RMS-4314	3/3	N	N	N	3/3		0, 9, 11, 15	
05-61C-MRL-12	RMS-4315	3/3	N	N	N	3/3		0, 9, 11, 15	
05-61C-MRL-12	RMS-4316	3/3	N	N	N	3/3		0, 9, 11, 15	
05-61C-MRL-12	RMS-4335	3/3	N	N	N	3/3		0, 9, 11, 15	
05-61C-MRL-12	RMS-4336	3/3	N	N	N	3/3		0, 9, 11, 15	
05-61C-MRL-12	RMS-4337	3/3	N	N	N	3/3		0, 9, 11, 15	
05-61C-MRL-12	RMS-4338	3/3	N	N	N	3/3		0, 9, 11, 15	

EPD&C/RMS APPENDIX F (05-61D1)
 NASA FMEA TO IOA WORKSHEET CROSS REFERENCE/RECOMMENDATIONS

IDENTIFIERS		NASA			IOA			RECOMMENDATIONS		
NASA FMEA NUMBER	ASSESSMENT IOA NUMBER	CRIT HW/F	SCREENS			CRIT HW/F	SCREENS		RESOLUTION CODES	ISSUE
05-61D-2002-1	RMS-4526	1/1				2/1R	1 P P	0, 3, 11		
05-61D-2002A-1	RMS-4530	2/1R	P	F	P	2/1R	1 P P	0, 7, 11		
05-61D-2026-1	RMS-4521	1/1				3/3		0, 3, 11		
05-61D-2027-1	RMS-4507	1/1				1/1		0, 11		
05-61D-2027-2	RMS-4508	2/1R	P	F	P	2/1R	1 P P	0, 7, 11		
05-61D-2028-1	RMS-4511	1/1				1/1		0, 11		
05-61D-2028-2	RMS-4512	2/1R	P	F	P	2/1R	1 P P	0, 7, 11		
05-61D-2029-1	RMS-4515	1/1				1/1		0, 11		
05-61D-2029-2	RMS-4516	2/1R	P	F	P	2/1R	1 P P	0, 7, 11		
05-61D-2030-1	RMS-4519	1/1				1/1		0, 11		
05-61D-2030-2	RMS-4520	2/1R	P	F	P	2/1R	1 P P	0, 7, 11		
05-61D-2031-1	RMS-4503	1/1				1/1		0, 11		
05-61D-2126-1	RMS-4265	2/1R	P	P	P	3/2R	NA NA	0, 3, 7, 11		
05-61D-2126-1	RMS-4331	2/1R	P	P	P	3/2R	NA NA	0, 3, 7, 11		
05-61D-2127-1	RMS-4243	2/1R	P	P	P	3/2R	NA NA	0, 3, 7, 11		
05-61D-2127-1	RMS-4309	2/1R	P	P	P	3/2R	NA NA	0, 3, 7, 11		
05-61D-2128-1	RMS-4209	2/1R	P	P	P	3/2R	NA NA	0, 3, 7, 11		
05-61D-2128-1	RMS-4287	2/1R	P	P	P	3/2R	NA NA	0, 3, 7, 11		
05-61D-2500-1	RMS-4574	2/1R	P	F	P	2/1R	1 P P	0, 7, 11		
05-61D-2500-1	RMS-4576	2/1R	P	F	P	2/1R	1 P P	0, 7, 11		
05-61D-2501-1	RMS-4550	2/1R	P	F	P	2/1R	1 P P	0, 7, 11		

EPD&C/RMS APPENDIX F (05-6ID1 Concluded)
 NASA FMEA TO IOA WORKSHEET CROSS REFERENCE/RECOMMENDATIONS

IDENTIFIERS		NASA			IOA			RECOMMENDATIONS			
NASA FMEA NUMBER	ASSESSMENT IOA NUMBER	CRIT HW/F	SCREENS			CRIT HW/F	SCREENS		RESOLUTION CODES	ISSUE	
05-61D-2501-1	RMS-4552	2/1R	P	F	P	2/1R	1	P	P	0, 7, 11	
05-61D-2502-1	RMS-4568	2/1R	P	F	P	2/1R	1	P	P	0, 7, 11	
05-61D-2502-1	RMS-4570	2/1R	P	F	P	2/1R	1	P	P	0, 7, 11	
05-61D-2503-1	RMS-4544	2/1R	P	F	P	2/1R	1	P	P	0, 7, 11	
05-61D-2503-1	RMS-4546	2/1R	P	F	P	2/1R	1	P	P	0, 7, 11	
05-61D-2504-1	RMS-4562	2/1R	P	F	P	2/1R	1	P	P	0, 7, 11	
05-61D-2504-1	RMS-4564	2/1R	P	F	P	2/1R	1	P	P	0, 7, 11	
05-61D-2505-1	RMS-4538	2/1R	P	F	P	2/1R	1	P	P	0, 7, 11	
05-61D-2505-1	RMS-4540	2/1R	P	F	P	2/1R	1	P	P	0, 7, 11	
05-61D-2506-1	RMS-4556	2/1R	P	F	P	2/1R	1	P	P	0, 7, 11	
05-61D-2506-1	RMS-4558	2/1R	P	F	P	2/1R	1	P	P	0, 7, 11	
05-61D-2507-1	RMS-4532	2/1R	P	F	P	2/1R	1	P	P	0, 7, 11	
05-61D-2507-1	RMS-4534	2/1R	P	F	P	2/1R	1	P	P	0, 7, 11	

EPD&C/RMS APPENDIX F (05-61D2)
 NASA FMEA TO IOA WORKSHEET CROSS REFERENCE/RECOMMENDATIONS

IDENTIFIERS		NASA			IOA			RECOMMENDATIONS		
NASA FMEA NUMBER	ASSESSMENT IOA NUMBER	CRIT HW/F	SCREENS			CRIT HW/F	SCREENS		RESOLUTION CODES	ISSUE
05-61D-2001-1	RMS-4523	3/3	NA	NA	NA	3/3			0, 13, 15	
05-61D-2002-2	RMS-4527	3/3	P	P	P	3/3			0, 11, 15	
05-61D-2002-2	RMS-4531	3/3	P	P	P	3/3			0, 11, 15	
05-61D-2003-1	RMS-4524	2/1R	P	P	P	2/1R	1	P P	0, 11	
05-61D-2003-1	RMS-4528	2/1R	P	P	P	2/1R	1	P P	0, 11	
05-61D-2003-2	RMS-4525	3/3	P	P	P	3/3			0, 11, 15	
05-61D-2003-2	RMS-4529	3/3	P	P	P	3/3			0, 11, 15	
05-61D-2026-2	RMS-4522	3/2R	NA	NA	NA	3/2R	1	P P	0, 11	
05-61D-2031-2	RMS-4504	3/1R	P	P	P	2/1R	1	P P	0, 5, 11	
05-61D-2032-1	RMS-4505	1/1	P	P	P	1/1			0, 11	
05-61D-2032-2	RMS-4506	3/1R	P	P	P	2/1R	1	P P	0, 5, 11	
05-61D-2033-1	RMS-4509	1/1	P	P	P	1/1			0, 11	
05-61D-2033-2	RMS-4510	3/1R	P	P	P	2/1R	1	P P	0, 5, 11	
05-61D-2034-1	RMS-4513	1/1	P	P	P	1/1			0, 11	
05-61D-2034-2	RMS-4514	3/1R	P	P	P	2/1R	1	P P	0, 5, 11	
05-61D-2035-1	RMS-4517	1/1	P	P	P	1/1			0, 11	
05-61D-2035-2	RMS-4518	3/1R	P	P	P	2/1R	1	P P	0, 5, 11	
05-61D-2036-1	RMS-4501	1/1	P	P	P	1/1			0, 11	
05-61D-2036-2	RMS-4502	3/1R	P	P	P	2/1R	1	P P	0, 5, 11	
05-61D-2129-1	RMS-4266	3/3	P	P	P	3/2R	1	NA NA	4, 7, 11, 15	X
05-61D-2129-1	RMS-4332	3/3	P	P	P	3/2R	1	NA NA	4, 7, 11, 15	X

EPD&C/RMS APPENDIX F (05-6102 Cont'd)
NASA FMEA TO IOA WORKSHEET CROSS REFERENCE/RECOMMENDATIONS

IDENTIFIERS		NASA			IOA			RECOMMENDATIONS		
NASA FMEA NUMBER	ASSESSMENT IOA NUMBER	CRIT HW/F	SCREENS			CRIT HW/F	SCREENS		RESOLUTION CODES	ISSUE
05-61D-2130-1	RMS-4244	3/3	P	P	P	3/2R	1	NA NA	4, 7, 11, 15	X
05-61D-2130-1	RMS-4310	3/3	P	P	P	3/2R	1	NA NA	4, 7, 11, 15	X
05-61D-2131-1	RMS-4210	3/3	P	P	P	3/2R	1	NA NA	4, 7, 11, 15	X
05-61D-2131-1	RMS-4288	3/3	P	P	P	3/2R	1	NA NA	4, 7, 11, 15	X
05-61D-2500-2	RMS-4578	3/1R	P	P	P	2/1R	1	P P	0, 3, 11	
05-61D-2501-2	RMS-4554	3/1R	P	P	P	2/1R	1	P P	0, 3, 11	
05-61D-2502-2	RMS-4572	3/1R	P	NA	P	2/1R	1	P P	0, 3, 11	
05-61D-2503-2	RMS-4548	3/1R	P	P	P	2/1R	1	P P	0, 3, 11	
05-61D-2504-2	RMS-4566	3/1R	P	P	P	2/1R	1	P P	0, 3, 11	
05-61D-2505-2	RMS-4542	3/1R	P	P	P	2/1R	1	P P	0, 3, 11	
05-61D-2506-2	RMS-4560	3/1R	P	P	P	2/1R	1	P P	0, 3, 11	
05-61D-2507-2	RMS-4536	3/1R	P	P	P	2/1R	1	P P	0, 3, 11	
05-61D-2508-1	RMS-4575 P	2/1R	P	NA	P	2/1R	1	P P	0, 7, 8, 11	
05-61D-2508-1	RMS-4577	2/1R	P	NA	P	2/1R	1	P P	0, 7, 8, 11	
05-61D-2508-2	RMS-4579	3/1R	P	P	P	2/1R	1	P P	0, 3, 11	
05-61D-2509-1	RMS-4551	2/1R	P	P	P	2/1R	1	P P	0, 7, 8, 11	
05-61D-2509-1	RMS-4553	2/1R	P	NA	P	2/1R	1	P P	0, 7, 8, 11	
05-61D-2509-2	RMS-4555	3/1R	P	P	P	2/1R	1	P P	0, 3, 11	
05-61D-2510-1	RMS-4569	2/1R	P	NA	P	2/1R	1	P P	0, 7, 8, 11	
05-61D-2510-1	RMS-4571	2/1R	P	NA	P	2/1R	1	P P	0, 7, 8, 11	
05-61D-2510-2	RMS-4573	3/1R	P	P	P	2/1R	1	P P	0, 3, 11	

EPD&C/RMS APPENDIX F (05-61D2 Concluded)
 NASA FMEA TO IOA WORKSHEET CROSS REFERENCE/RECOMMENDATIONS

IDENTIFIERS		NASA			IOA			RECOMMENDATIONS	
NASA FMEA NUMBER	ASSESSMENT IOA NUMBER	CRIT HW/F	SCREENS		CRIT HW/F	SCREENS		RESOLUTION CODES	ISSUE
05-61D-2511-1	RMS-4545	2/1R	P	NA P	2/1R	1	P P	0, 7, 8, 11	
05-61D-2511-1	RMS-4547	2/1R	P	NA P	2/1R	1	P P	0, 7, 8, 11	
05-61D-2511-2	RMS-4549	3/1R	P	P P	2/1R	1	P P	0, 3, 11	
05-61D-2512-1	RMS-4563	2/1R	P	NA P	2/1R	1	P P	0, 7, 8, 11	
05-61D-2512-1	RMS-4565	2/1R	P	NA P	2/1R	1	P P	0, 7, 8, 11	
05-61D-2512-2	RMS-4567	3/1R	P	P P	2/1R	1	P P	0, 3, 11	
05-61D-2513-1	RMS-4539	2/1R	P	NA P	2/1R	1	P P	0, 7, 8, 11	
05-61D-2513-1	RMS-4541	2/1R	P	NA P	2/1R	1	P P	0, 7, 8, 11	
05-61D-2513-2	RMS-4543	3/1R	P	P P	2/1R	1	P P	0, 3, 11	
05-61D-2514-1	RMS-4557	2/1R	P	NA P	2/1R	1	P P	0, 7, 8, 11	
05-61D-2514-1	RMS-4559	2/1R	P	NA P	2/1R	1	P P	0, 7, 8, 11	
05-61D-2514-2	RMS-4561	3/1R	P	P P	2/1R	1	P P	0, 3, 11	
05-61D-2515-1	RMS-4533	2/1R	P	NA P	2/1R	1	P P	0, 7, 8, 11	
05-61D-2515-1	RMS-4535	2/1R	P	NA P	2/1R	1	P P	0, 7, 8, 11	
05-61D-2515-2	RMS-4537	3/1R	P	P P	2/1R	1	P P	0, 3, 11	

Independent Orbiter Assessment
Assessment of the EPD&C/RMS FMEA CIL

1.0 EXECUTIVE SUMMARY

The McDonnell Douglas Astronautics Company (MDAC) was selected in June 1986 to perform an Independent Orbiter Assessment (IOA) of the Failure Modes and Effects Analysis (FMEA) and Critical Items List (CIL). Direction was given by the STS Orbiter and GFE Projects Office to perform the hardware analysis using the instructions and ground rules defined in NSTS 22206, Instructions for Preparation of FMEA and CIL, 10 October 1986.

The IOA effort first completed an analysis of the Electrical Power Distribution and Control (EPD&C)/Remote Manipulator System (RMS) hardware, generating draft failure modes and potential critical items. To preserve independence, this analysis was accomplished without reliance upon the results contained within the NASA FMEA/CIL documentation. The IOA analysis of the EPD&C/RMS hardware initially generated ~~three hundred and forty-five (345)~~ failure mode worksheets and identified ~~one hundred and seventeen (117)~~ Potential Critical Items (PCIs) before starting the assessment process. These analysis results were compared to the proposed NASA Post 51-L baseline of ~~one hundred and thirty-two (132)~~ FMEAs and ~~sixty-six (66)~~ CIL items, which were generated using the NSTS-22206 FMEA/CIL instructions. IOA generated failure mode analysis worksheets for both port and starboard Remote Manipulator Systems whereas the NASA generated FMEAs for only one system (did not specify which). The IOA analysis was performed on a component level for components assigned reference designator numbers on the drawings with one component per worksheet. The NASA analysis was performed with like multiple similar components on one FMEA. In some cases the NASA FMEAs were generated for an entire circuit without necessarily specifying the components included in the circuit by any identification number, thus direct comparisons of the IOA and NASA analyses were not meaningful in the sense of numbers of failures and identification of criticalities that have any uniformity. Efforts to compare the two analyses required consolidation of components in all but a few cases where the items were single point failure items as some of the switches were found to be. Twenty-eight (28) additional IOA failure mode analysis worksheets were generated to facilitate comparison. Upon completion of the assessment, five (5) issue items were identified that involved critical items where IOA recommends that NASA FMEAs generated for that failure mode of the component or where the NASA Criticality for that failure mode of that component be upgraded. There were also six (6) issues identified where IOA recommends upgrading of the NASA assigned criticality but these are not critical items list candidates.

Some of the miscompares arose due to differences between the NASA and IOA FMEA/CIL preparation instructions. NASA had used an older ground rules document which has since been superseded by the NSTS 22206 used by the IOA. After comparison, there were no other discrepancies found that were not already identified by NASA, and the remaining issues may be attributed to differences in ground rules.

It may be noted that numerical values appear to disagree between charts and tables. Figure 1 "Remote Manipulator Arm" block lists 5 issues for FMEAs and 5 issues for CIL items. The FMEA issues are also CIL issues. Figure 1 "Arm/Shoulder Jettison" block lists 6 FMEA issues which are not considered critical items.

