

N90-19271 522-19

REMOTE ATTITUDE MEASUREMENT SENSOR
(RAMS)

219 968
308.

H. W. Davis
Ball Aerospace Systems Group
Boulder, Colorado

LARGE SPACE STRUCTURE (LSS) ISSUES

The use of large space platforms for Earth observations is advantageous because it results in improved capabilities such as coincident observations, shared resources, serviceability and growth potential. However, large platform structures produce lower mechanical resonance frequencies and dynamic structural interactions which create severe problems for precision-pointed instruments.

Growth in spacecraft size drives us to flexible structures because rigid structures would exceed launch weight constraints. Flexible structures further complicate control system modeling and analysis, so on-orbit system identification is needed. Thermal effects are exaggerated by increased structural dimensions, resulting in larger distortions to surface figure and structural alignment. If distortions become intolerable, active structural control may be required. In any event, some form of active vibration damping may be necessary to reduce payload instrument disturbances caused by structural vibrations and spacecraft subsystem disturbance sources.

When payload instruments were mounted on smaller, rigid platforms, pointing knowledge could be derived from the spacecraft attitude control system (ACS). With flexible platforms, this is no longer feasible. Payload pointing accuracy is degraded by onboard disturbances that excite resonance modes above ACS cutoff (approximately 0.1 Hz) and below the region where intrinsic structural damping becomes effective (approximately 100 Hz). Isolation of payloads from these base motion disturbances requires precise, high bandwidth position data such as that provided by Ball's Remote Attitude Measurement Sensor (RAMS). Other equally important uses of RAMS include alignment calibration and coalignment of payload instruments and transfer of alignment/attitude information between inertial reference units and payload mounting surfaces.

- **Flexible structure**
 - **Launch weight limitations preclude rigid structure**
 - **On-orbit system identification needed**
 - **Attitude control is more difficult**
 - **Thermal distortions exaggerated by size**
 - **Active structural control may be required**
 - **Active vibration isolation may be required**

- **Payload pointing**
 - **Determination of pointing knowledge**
 - **Compliance with accuracy requirements (stability, jitter)**
 - **Isolation from base motion disturbances**
 - **Calibration and coalignment of payloads**
 - **Alignment transfer may be required**

SYSTEMS INTEGRATION AND VALIDATION

Recent conference publications (refs. 1 and 2) have recognized the importance of an integrated system-level approach to the design of active structural control systems. Control/structures interaction was the theme of two recent NASA/DOD technology conferences that promoted interdisciplinary cooperation as the essential element for optimal design of LSS. Extensive efforts have been devoted to each of the technology elements shown below, and much progress has been made. Advances have been made in the development of piezoelectric actuators, viscoelastic damping materials, low-expansion composite materials, and advanced processors for distributed control systems. Up until now, however, the sensor technology area seemed to be trailing the other technologies in meeting the needs of structural characterization and control. RAMS is the only optical sensor today that satisfies the LSS requirements for accuracy, update rate, number of targets, simplicity, reliability, and technological maturity.

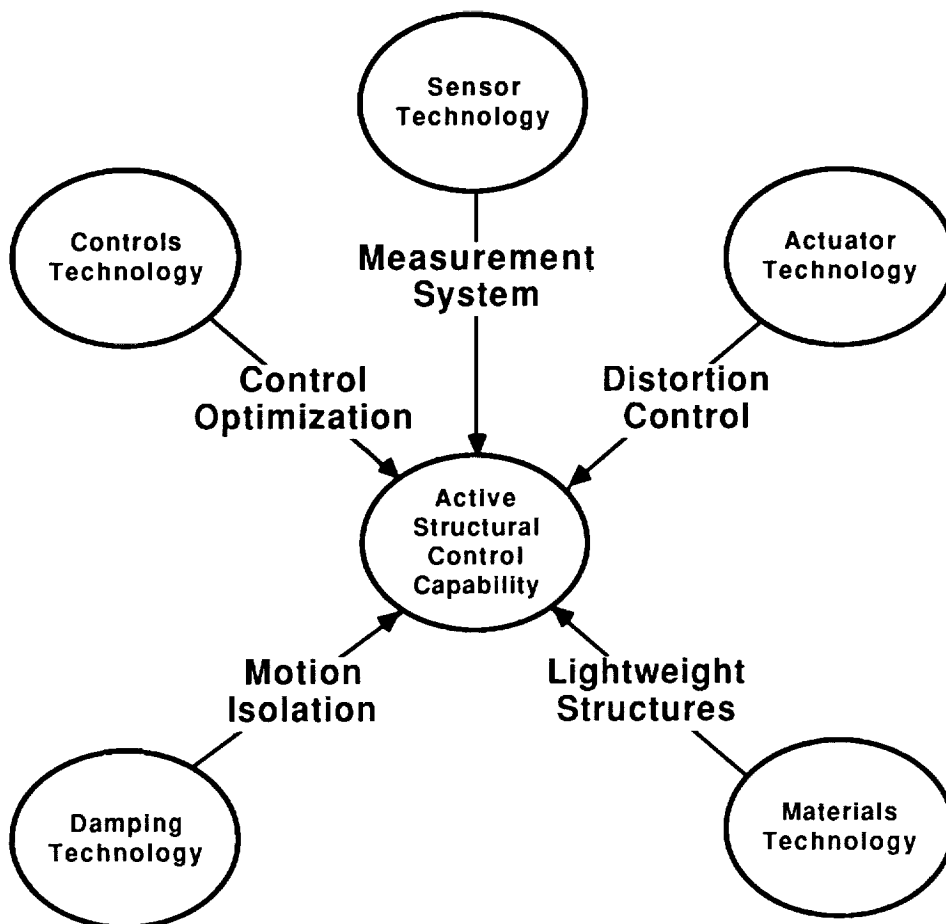

SPACE SYSTEMS REQUIRING HIGH-ACCURACY, HIGH-BANDWIDTH SENSORS

There are many space applications which require or benefit from the use of high-accuracy, high-bandwidth sensors such as RAMS. Space structures, especially large, flexible structures, require a means of measuring both translation and rotation of numerous points on the structure for systems identification and for active control of the surface figure or alignment of the structure. Deployable structures also benefit from sensors that monitor the deployment, control deployment sequences and rates, and verify proper alignment and latching when deployment is completed. Attached payloads need alignment information for calibration purposes and for proximity operations during docking, installation, or servicing. If the payload requires precise pointing, transfer of attitude data from the platform's inertial reference unit may also be needed. Finally, a variety of space vehicles planned for support of space station operations (OTV, OMV,* polar and co-orbiting platforms) will require proximity knowledge for docking, interfacing, and avoidance.

*Orbital Transfer Vehicle (OTV); Orbital Maneuvering Vehicle (OMV).

- **Space structures:**
 - Active control**
 - Deployment**
 - Surface figure**
 - Systems identification**
 - (Structural dynamics)**

- **Payloads:**
 - Alignment calibration**
 - Alignment transfer**
 - Coalignment of multiple payloads**
 - Docking (Installation, servicing)**

- **Vehicles (OTV, OMV, platforms):**
 - Docking**
 - Proximity operations**
 - Attitude transfer**

DESIRED ATTRIBUTES OF LSS SENSORS

The primary attributes sought in any LSS sensor are listed below. Although performance characteristics vary with each specific application, accuracy in the sub-millimeter range and update rates of at least 250 Hz are generally required to support systems identification and active control of LSS with disturbances up to 25 - 50 Hz. The greater the number of targets (structural locations) monitored, the better the characterization of its dynamic behavior. Low complexity leads to higher reliability and maintainability. Sensors having a non-obtrusive (non-contacting) nature can be used to study photovoltaic solar arrays and other film-like structures without the sensor's mass influencing the dynamics of the structure. Lastly, it is desirable that the LSS sensor have broad application (multiple uses) and be versatile (to accommodate configuration changes easily).

- **High accuracy**
- **High update rate**
- **Multiple targets**
- **Low complexity**
- **Low cost**
- **Reliable**
- **Non-obtrusive**
- **Broad application**

LSS SENSOR TRADEOFFS

Ball's selection and pursuit of the RAMS concept as the preferred LSS sensor resulted from comparisons and tradeoffs of many competing technologies. After 30 years of electro-optical sensor experience, including star sensors, Sun sensors, laser rangefinders, lidars, and interferometers, we clearly understand the capabilities and limitations of each. We have actually built and tested sensors from each of these technologies. RAMS was developed using space-proven technology directly applicable to LSS. Proprietary algorithms developed as part of our star tracker work permit subpixel interpolation and focus compensation. Ball also built the Retroreflector Field Tracker (RFT), the first solid-state sensor flown in space. The RFT measured dynamic structural behavior as part of the Solar Array Flight Experiment (SAFE). Finally, we conducted an extensive literature search and evaluated many sensor concepts before recommending the RAMS concept to Goddard Space Flight Center for coalignment of Shuttle payloads.

- **Based on 30 years of electro-optical sensor experience**
 - Star trackers
 - Star scanners
 - Sun sensors
 - Laser rangefinders
 - Interferometers

- **Derived from space-proven LSS technology**
 - Star tracker algorithms
 - Retroreflector field tracker (RFT)

- **Supported by the NASA/GSFC payload coalignment study literature search and evaluation**

RETROREFLECTOR FIELD TRACKER (RFT)
WAS TESTED ON STS 41-D

The RFT was designed to monitor the structural shape of a large, flexible solar array panel deployed from the cargo bay of the Shuttle. The RFT used five laser diodes to illuminate 23 retroreflective tape targets distributed throughout the surface area of the panel. The sensor head was mounted at the base of the array, set back 75 in., and tilted 14.8 deg from vertical in order to have a clear view of all targets. Reflected images were focused onto a 256 x 256 pixel charge injection device (CID) detector and tracked with the aid of three Z-80 microprocessors (ref. 3).

The solar array panel was 12 ft wide and 105 ft long when fully deployed. At maximum range (i.e., top of the array), the RFT was capable of measuring displacements of ± 3 mm with an update rate of 2 Hz. Due to concerns about the dynamic uncertainties of this structure, the panel was never deployed beyond 70 percent of its length. All RFT on-orbit testing took place in orbital darkness; a companion sensor using photogrammetric techniques was employed during the sunlit half of the orbit.

The demonstrated technology derived from RFT has been improved greatly and incorporated in RAMS. Accuracy has been increased by a factor of 200 and update rate has been improved by a factor of 100. The number of targets tracked simultaneously has also increased four-fold. These dramatic improvements combined with proven sensor technology offer low-risk, low-cost solutions to a variety of space sensor needs.

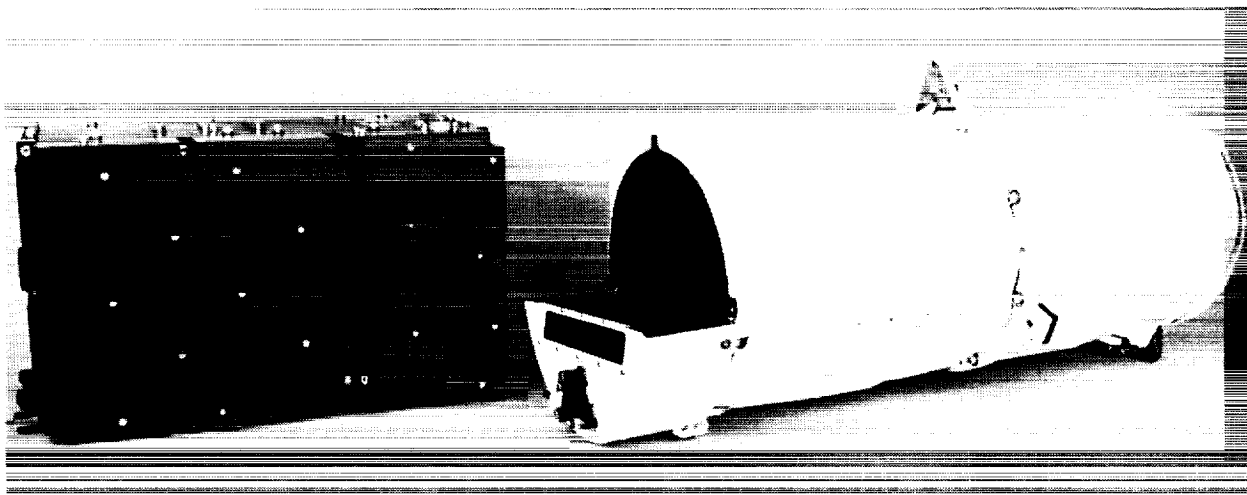

ORIGINAL PAGE
BLACK AND WHITE PHOTOGRAPH

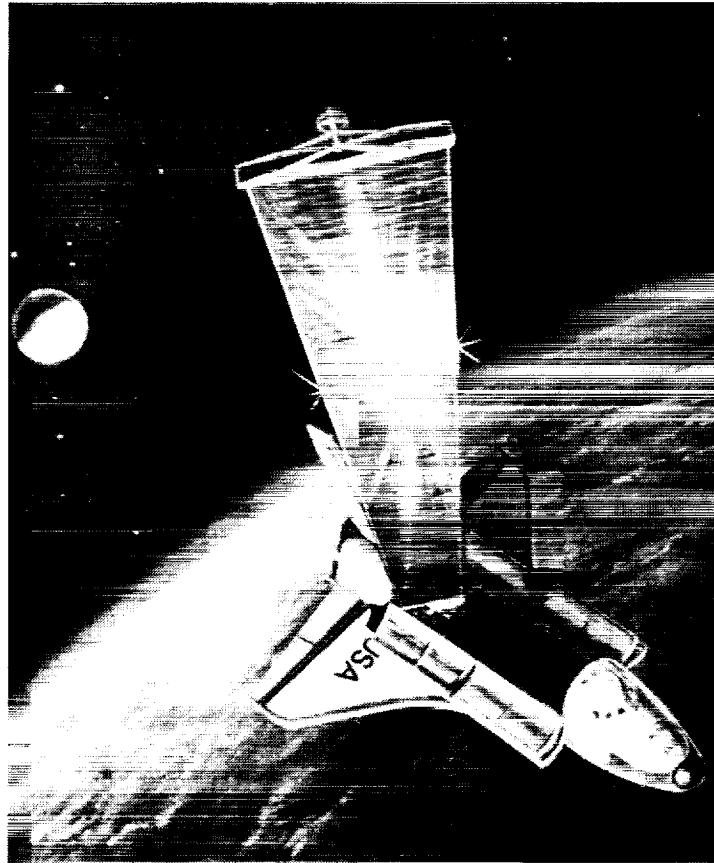

**ORIGINAL PAGE IS
OF POOR QUALITY**

- **RFT monitored structural shape of a large, flexible solar panel**
 - **12 ft x 105 ft array**
 - **Acquired and tracked 23 retroreflective targets**
 - **Accuracy: +3 mm at 32m range**
 - **Update rate: 2 Hz**

- **RFT's space-proven technology is directly applicable to:**
 - **Large space structure alignment control**
 - **Star tracking**
 - **Rendezvous and docking sensor**
 - **Mirror shape control**

SAFE/RFT FLIGHT EXPERIMENT "LESSONS LEARNED"¹

The SAFE solar array panel and supporting mast behaved characteristically like a generic class of future large space structures. The structure exhibited very low natural frequencies (0.035 Hz, first mode) and densely spaced modes (> 33 modes per Hz). Other similarities included type of construction, strength-to-weight ratios, and the inability to adequately perform dynamic tests on the ground (ref. 4).

An unexpected curvature of the solar array occurred on the dark side of the orbit, resulting in higher stiffness than predicted by analyses. Flight configuration differed from pretest analysis to such an extent that update of the analytical models was necessary for correlation and verification. It is significant that this anomaly occurred despite the normal care taken in design to envision and prepare for on-orbit use. Thus, this anomaly may well be representative of "surprises" to be expected of future LSS.

One favorable observation from the experiment was that structural damping was significantly higher than previous launch or space vehicle experience, and higher than the 0.5 percent predicted during pretest analyses.

- Behaved characteristically like large space structures:
 - Very low natural frequencies (0.035 Hz, first mode)
 - Densely spaced modes (>33 modes per Hz)
- Unexpected curvature of solar array occurred on the dark side of the orbit
 - Flight configuration differed from analysis model
 - Anomaly occurred despite care taken in design
- Damping of the SAFE was significantly higher than previous launch or space vehicle experience

¹ Schock, Richard W., "Solar Array Flight Dynamics Experiment," AAS Guidance and Control Conference, Keystone, Colorado, February 1-5, 1986

SOLAR ARRAY CURVATURE EXPERIENCED DURING
DEPLOYMENT FROM STS CARGO BAY

This picture shows the solar array curvature experienced during orbital darkness while deployed to 70 percent of its length. The maximum measured curvature was 40 cm in depth and occurred near orbital midnight. The RFT was designed to track all targets and to label them with respect to predefined windows or "boxes." The unexpected curvature caused some targets to be displaced outside of the "boxes" and to be mislabelled. However, all targets were tracked and correct labelling was reconstructed after the mission using angular data. Thus, no target information was lost and the RFT's performance was declared 100 percent successful.

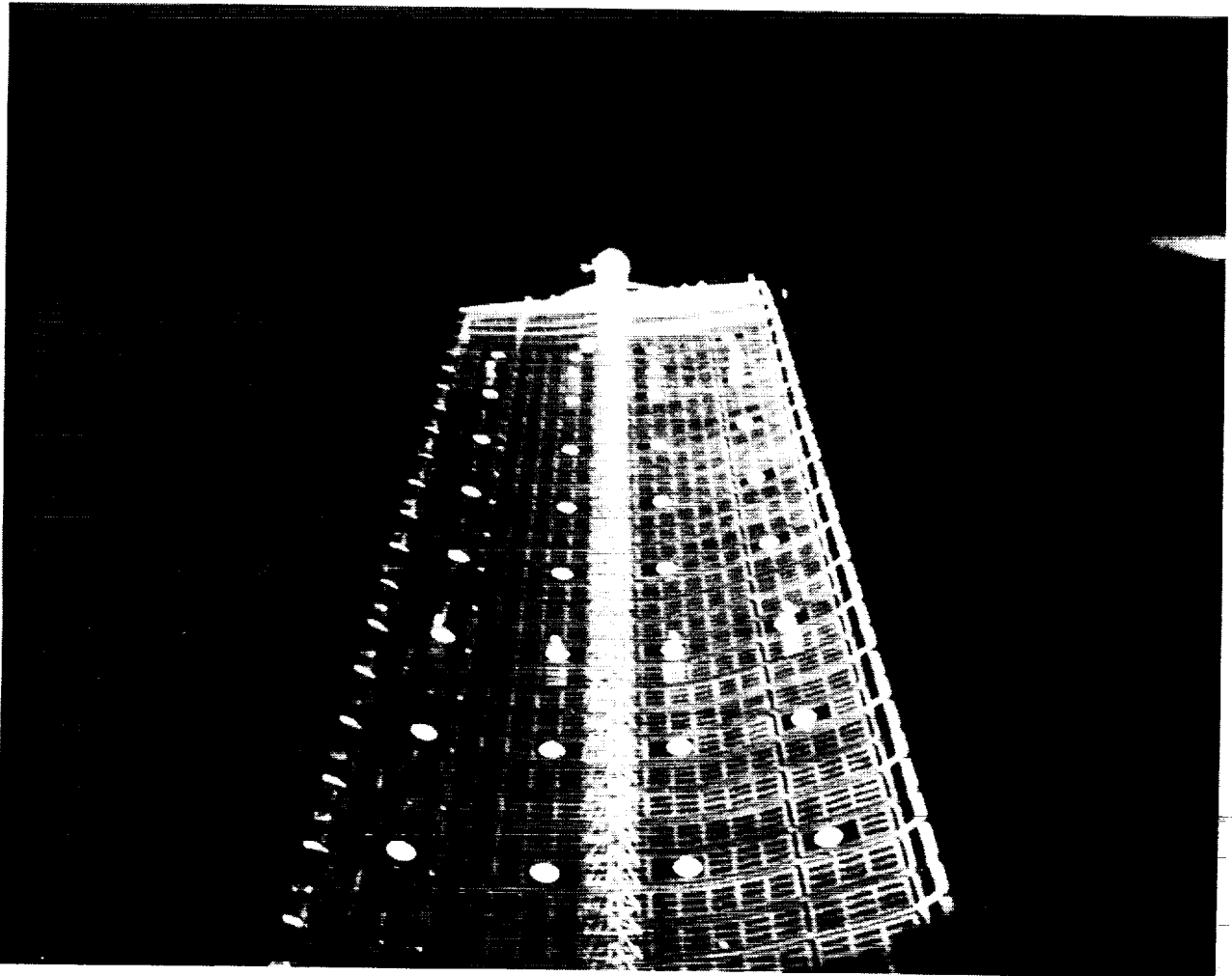

ORIGINAL PAGE IS
OF POOR QUALITY

- **Control of flexible structures**
- **Calibration/alignment of payloads**
- **Coalignment of multiple payloads**
- **Attitude transfer**
- **Surface figure measurement**

RECOMMENDED APPROACH

Ball has evaluated many of the foreseeable applications for high-accuracy sensors with large space structures (systems identification, active structural control, vibration isolation, surface figure measurement, alignment transfer, alignment/coalignment of payloads, and others), based on our experience and our knowledge of state-of-the-art sensor technologies. As a result, we have concluded that RAMS offers the optimal solution for most of these applications. RAMS consists of a simple electro-optical design, much less complex than lidar or interferometric devices. It can be applied to a wide variety of applications as suggested earlier, and its design is founded on well-established space sensor heritage. No other sensor offers equivalent high levels of resolution, target capacity, and update rate in a single device while accommodating the need for unobtrusive and versatile usage. RAMS provides direct position readout, eliminating the need to integrate a signal that represents an acceleration value. RAMS can also measure static displacements, another shortcoming of accelerometer-based sensor systems. Finally, the maturity and space heritage of RAMS technology makes it available at reasonably low cost and with low technological risk.

Review of applications and sensor concepts resulted in selection of the RAMS for monitoring of large space structures

- **Simple electro-optical design**
- **Broad application**
- **Well established heritage**
- **High precision (1:100,000)**
- **Accommodates many targets (>100)**
- **High data rates (up to 10 KHz-all targets)**
- **Non-contacting (unobtrusive)**
- **Versatile and easily installed**
- **Direct position readout**
- **Low cost**
- **Low risk**

REMOTE ATTITUDE MEASUREMENT SENSOR (RAMS)

This drawing represents an early prototype concept for RAMS and illustrates the principal elements of the sensor system. A light source (typically a laser diode) is used to illuminate a reflective target attached to the structure of interest. The target might be a flat mirror, a retroreflective mirror, or retroreflective tape, depending on the type of displacements to be measured (translation or rotation). In some cases, active targets (e.g., laser diodes) might be used. The reflected image is focused by a cylindrical lens in the sensor head onto a linear (i.e., single row of pixels) charge coupled device (CCD) detector. Displacement of the mirror will cause the focused image to move along the CCD, giving an indication of the angular change. As illustrated here, a 2,048-pixel CCD with the characteristics shown can provide angular resolution of 0.1 arcsecond and translation resolution of 1.3 micrometer at 2.5-meter range. Position readings for three targets are displayed with light-emitting diodes mounted in a separate display box.

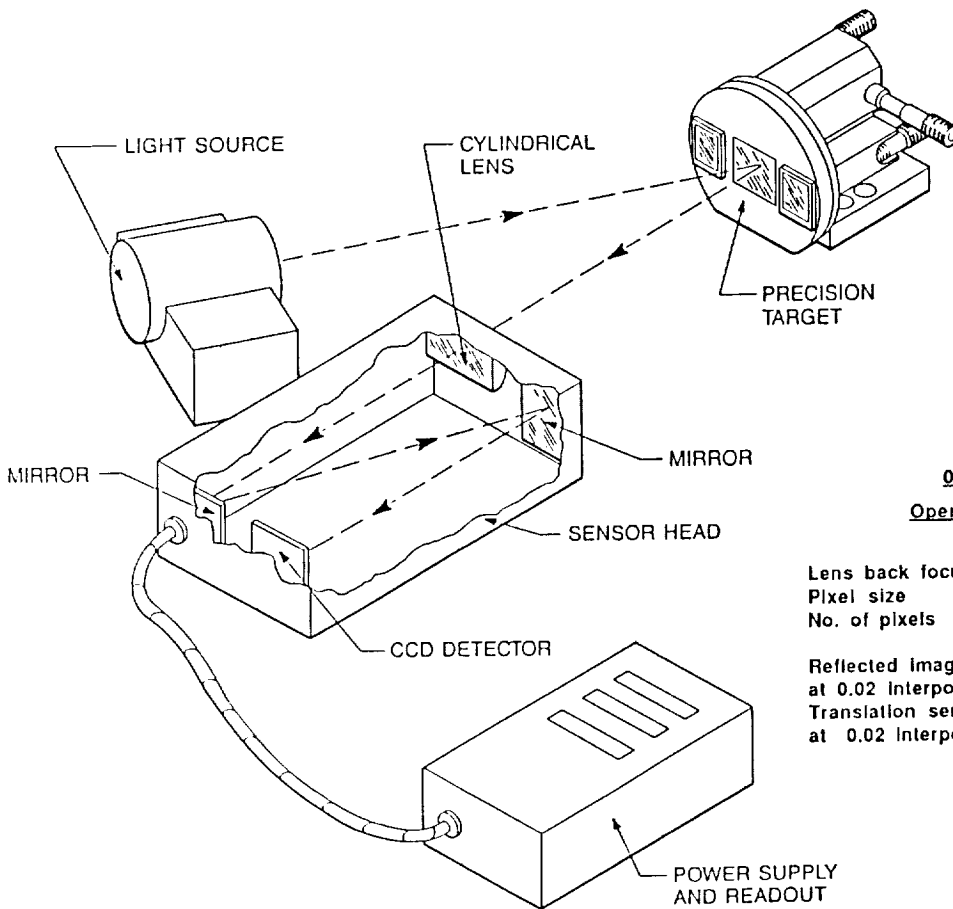

0.50m BFL Sensor
Operating Characteristics

Lens back focus =	0.50m
Pixel size	13 μm
No. of pixels	2,048

Reflected image sensitivity - 5.36 arc sec/pixel
 at 0.02 Interpolation = 0.1 arc sec
 Translation sensitivity (2.5m range)
 at 0.02 Interpolation = 1.3 μm

SENSOR CONCEPT

The cylindrical lens creates a line image and ensures that the target image is focused on the narrow, linear CCD detector. This configuration provides a sensitive plane (as shown) parallel to the length of the CCD and a nonsensitive plane perpendicular to it. Thus, one CCD and lens assembly provides a single-axis displacement sensor. If two-axis measurements are needed, two linear CCDs can be mounted orthogonally with individual lens assemblies inside a single sensor head, giving the capability to measure two-axis displacements. This same configuration can also provide data about a third axis (rotations about the line of sight), provided that two retroreflective mirrors are used with adequate spacing to ensure proper resolution.

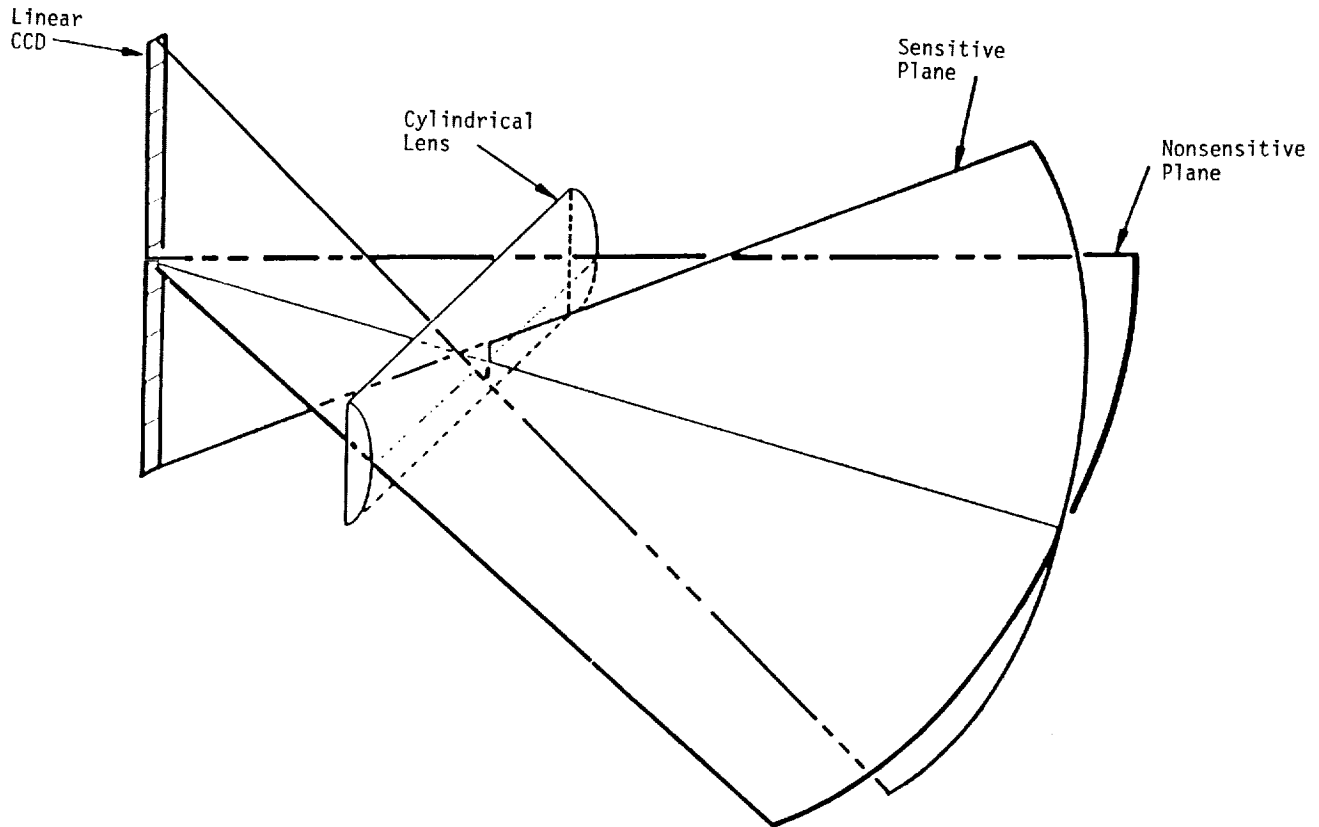

SUBPIXEL SENSING

This figure illustrates the concept used to achieve high resolution with RAMS. When the target image is focused on the CCD, its energy is spread over several pixels as shown. Unique Ball algorithms are employed to identify the radiometric center of the distributed image and to interpolate its position to 1.5-percent of a pixel. These proprietary algorithms were developed by Ball as part of our star tracker development efforts and have been conclusively demonstrated.

BASG interpolation algorithms achieve 0.015-pixel resolution

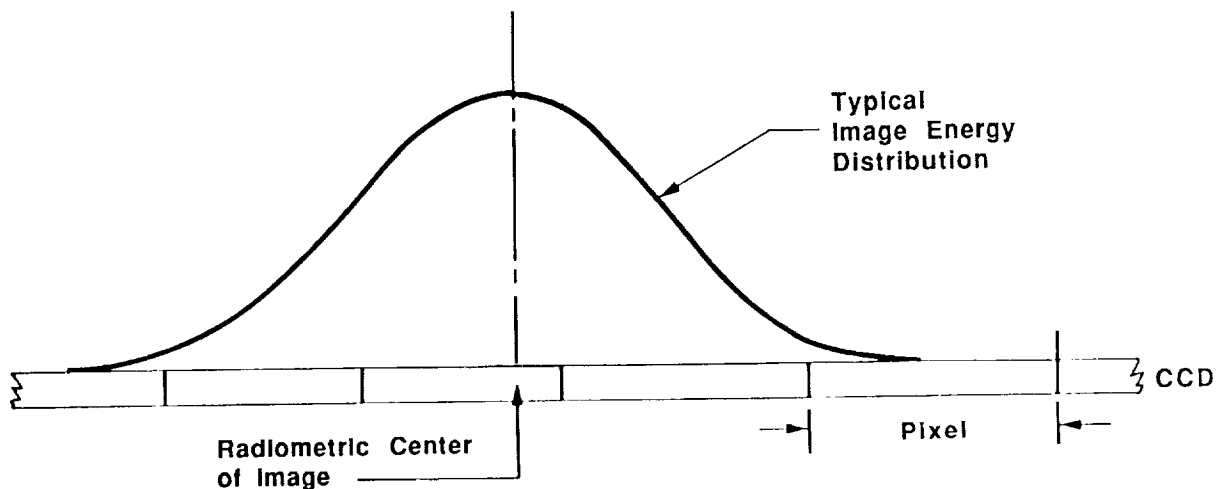

IN-PLANE SENSING

This figure further illustrates the relationship between angular target rotation and displacement measurements by the linear CCD. As depicted, an angular rotation about the X-axis that produces a line-of-sight displacement of the reflected image, $\Delta\theta_X$, results in an image displacement along the CCD that is directly proportional to the angular displacement of the mirror. This linear displacement along the CCD is measured by the change in pixel position (both integer and fractional values).

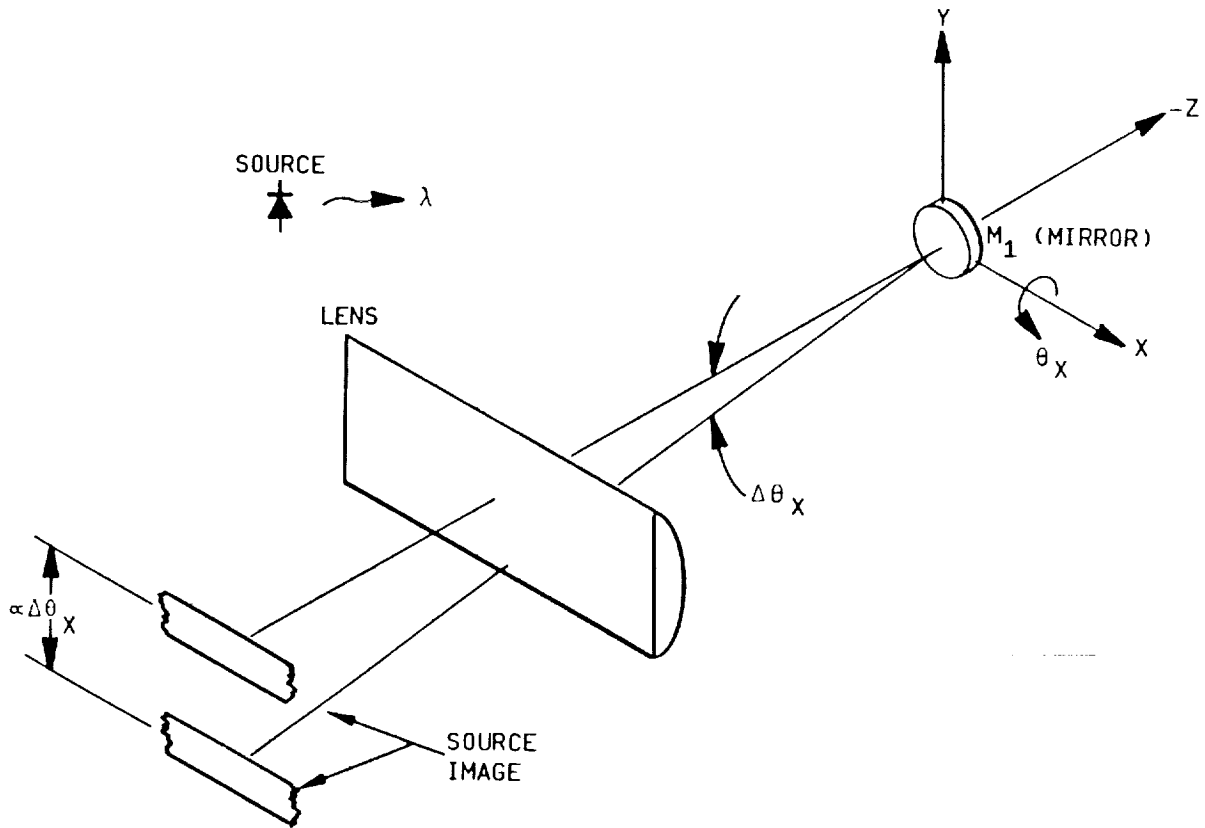

RAMS SENSOR HEAD

The prototype RAMS sensor head (shown here) incorporates a single linear CCD detector and a cylindrical lens. The enclosure on the rear houses the pre-amplifier circuit boards. The post above the sensor head supports a laser diode used for illumination of mirrors or retroreflective targets. To illustrate the compact nature of this sensor head, the length of the front edge of the base plate is only 6-5/8 in.

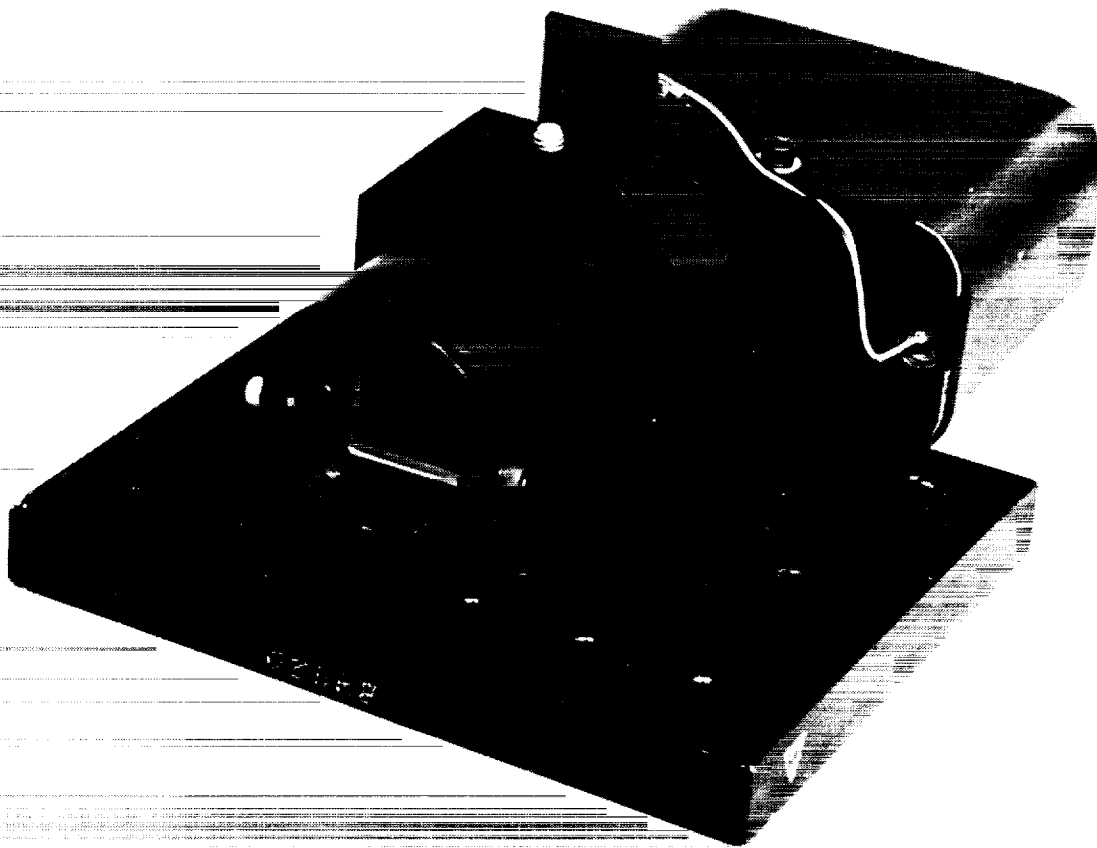

ORIGINAL PAGE
BLACK AND WHITE PHOTOGRAPH

RAMS DISPLAY BOX

The display box for the prototype RAMS incorporates the analog and digital processing circuitry, a power supply, and three light-emitting-diode (LED) displays. These displays depict position data for three targets in terms of pixel position (integer and fractional values). For example, the top LED shows "1063.458," indicating the image centroid is located approximately at the midpoint of the 1,064th pixel. For the optical configuration and target geometry used in this demonstration, a change in position reading of one pixel represented an angular displacement of the reflected image of approximately 25 arcseconds (121 microradians). In most laboratory demonstrations of this prototype, stable readings have been achieved on the order of one arcsecond.

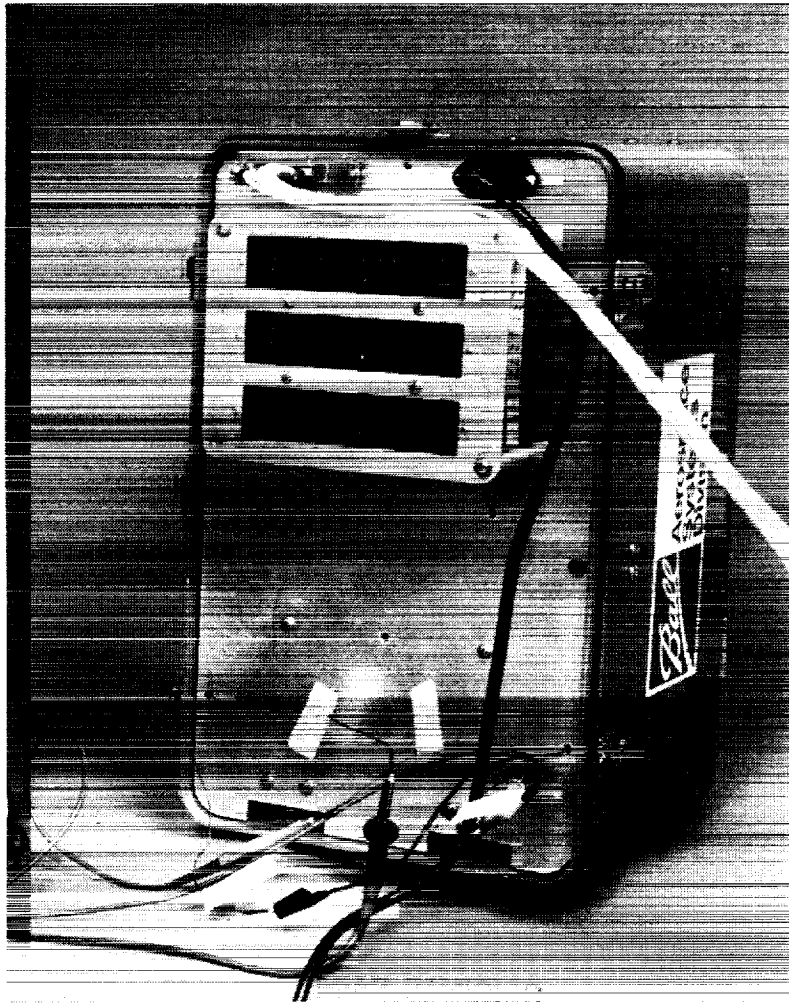

ORIGINAL PAGE
BLACK AND WHITE PHOTOGRAPH

**SENSOR SIGNAL DISPLAY SHOWING TWO
TARGETS AND INDIVIDUAL PIXELS**

This photograph of an oscilloscope display shows the CCD detector response to two reflected images, one from a flat mirror and one from a retroreflector. Both images are distributed over multiple pixels, and the individual pixel responses can clearly be seen. The distinction to be made between the two types of targets is that the flat mirror is sensitive to angular displacements and the retroreflector is sensitive to translation displacements. With the proper mix of both types of targets, simultaneous translation and rotation measurements can be decoupled from each other.

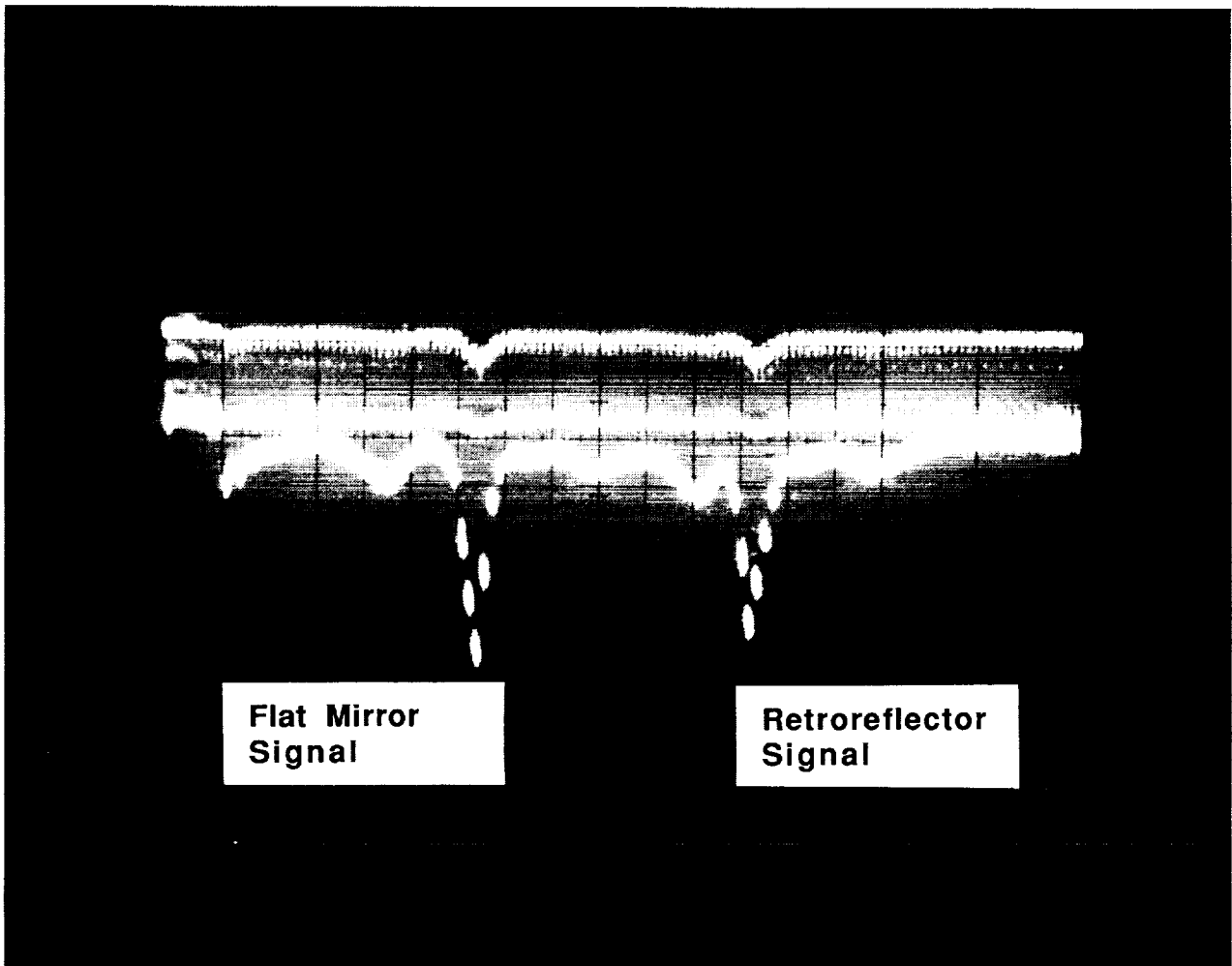

**ORIGINAL PAGE IS
OF POOR QUALITY**

RAMS PROTOTYPE

This table describes the characteristics of Ball's current RAMS prototype hardware. It incorporates a 2,048-pixel linear CCD array and a 106-mm cylinder lens. A field flattener is used for specific optical configurations. Three laser diodes serve as active targets, but the option remains to use a single laser diode to illuminate passive targets (either retroreflectors or flat mirrors). In the present configuration, each pixel subtends an angle equivalent to 25 arcseconds. Applying a conservative 2-percent interpolation factor, the sensor's resolution is 0.5 arcsecond of rotation and 0.0003 in. translation (at 11.1 ft range). Although the prototype can display target position for only three targets at once, it is capable of measuring 100 targets simultaneously and updating each target 250 times per second. This update rate is achieved with off-the-shelf electronics parts. Proper screening of parts would permit a 1000 Hz update rate with no change in design.

- **Sensor: CCD linear array (2048 pixels, each 13 μ m wide)**

- **Optics: Cylinder lens (106 mm); field flattener**

- **Sources: Laser diodes (3 mW maximum power)**

- **Reflectors: Retroreflectors; flat mirrors**

- **Sensitivity: 25 arc sec per pixel**

- **Accuracy (at 0.02 interpolation):**
 - **Rotation: 0.5 arc sec**
 - **Translation: 0.3 mils (at 11.1 ft range)**

- **Update rate: 250 Hz (capable of 1000 Hz)**

- **Capacity: Measures up to 100 targets simultaneously
(prototype limited to 3 displays)**

RAMS APPLICATIONS

Many of the potential applications for RAMS have already been mentioned or alluded to, but a summary is appropriate here. Control of flexible structures includes displacement sensor feedback for a variety of large flexible structures (platforms, trusses, booms) to monitor and control quasi-static distortions and dynamic disturbances. Calibration/alignment of payloads includes measurements to confirm that the payload instrument is properly mated with its support structure and that the instrument's axes (or boresight) are properly oriented for its mission. Coalignment of multiple payloads includes concurrent alignment measurements for two or more instruments to verify that all are pointed at the same target. Attitude transfer implies measuring the relative attitude differences between an instrument payload and an inertially referenced fixture, and calculating the inertial attitude of the instrument based on these differences. Finally, surface figure measurement includes measuring the position of numerous points on the surface of an antenna or other structure to verify the maintenance of proper shape or figure.

SPACE STATION STRUCTURAL CHARACTERIZATION EXPERIMENT (SSSCE)

This figure illustrates the Phase 1 configuration for the Space Station Freedom, scheduled to be constructed in space starting in 1995. The Space Station Structural Characterization Experiment (SSSCE) is a proposed space flight experiment to examine structural dynamic behavior of the station as part of an OAST Space Technology Program. SSSCE objectives include identifying mode shape, frequency, and damping of targeted structural modes for each stage of assembly through Phase 1. Structural behavior of the truss assembly will be measured in response to intentional excitations. The experiment will provide data with which to evaluate math modeling and ground test technology for large space structures. The RAMS concept has been evaluated and determined to be the leading displacement measurement candidate for the SSSCE.

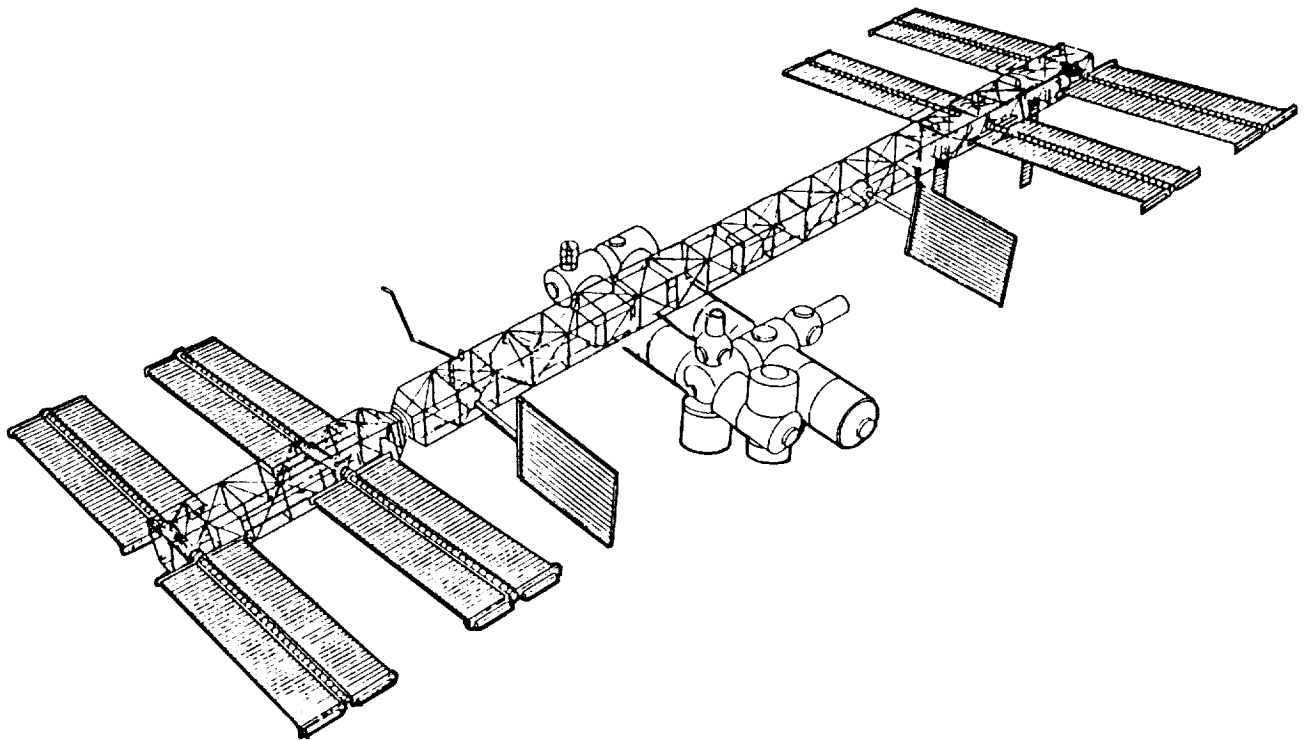

Phase 1 Space Station

SSSCE BASELINE CONFIGURATION WITH RAMS

This figure illustrates the baseline configuration for using RAMS to monitor truss distortions and disturbances on the station. RAMS is shown mounted on the Mobile Transporter (MT), a translating platform equipped with a remote manipulator arm and used for servicing of payloads and other hardware on the station. The MT is positioned in the center of the transverse boom during RAMS measurements and rigidly attached to the truss structure. Using a spherical lens with a 14.9 deg field of view, RAMS can monitor retroreflective tape targets attached to each structural node (at 5m spacings) between the 5m and 70m range. A total of six sensors are required to view both halves of the transverse boom and measure displacements normal to the longitudinal axis of the boom (X and Z) as well as rotation about the longitudinal axis (Y). With this configuration, RAMS can sense displacements as small as 137 μm at the maximum range of 70m.

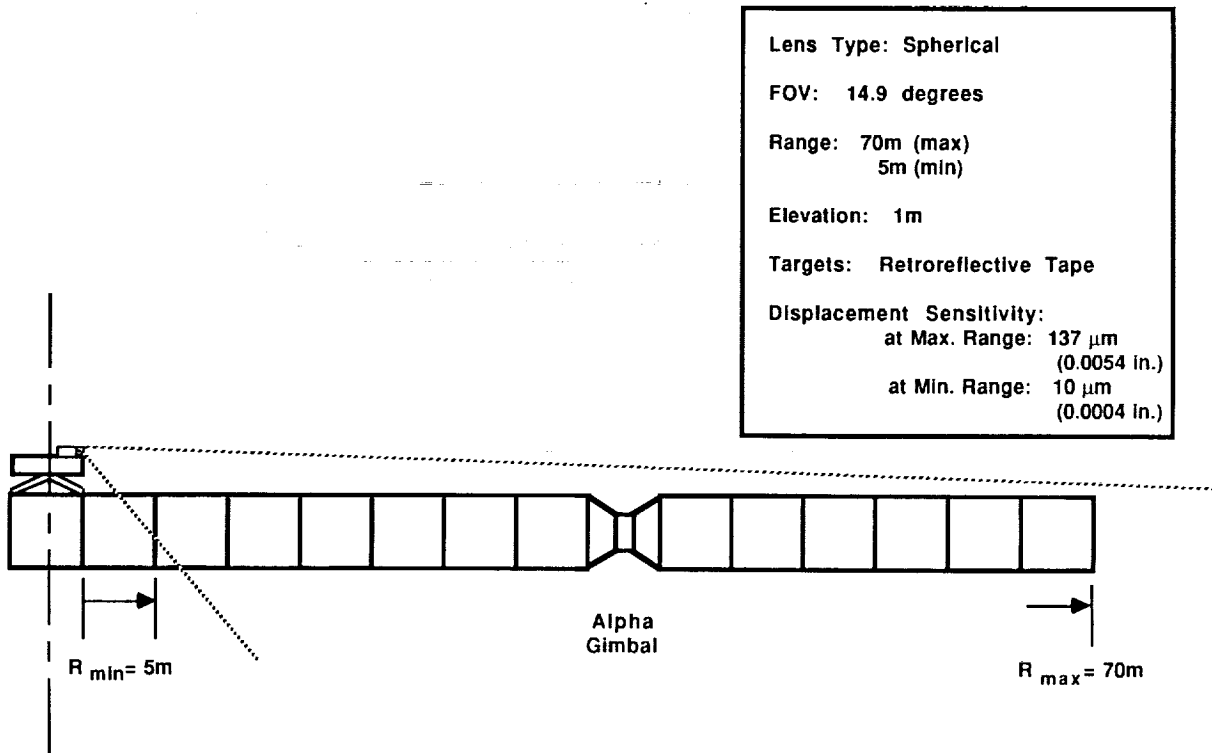

CONTROL AND STRUCTURES EXPERIMENT IN SPACE (CASES)

CASES is another on-orbit structural dynamics experiment with applications for RAMS. This shuttle-based experiment includes a boom tip assembly or mask mounted on top of a 32m-long flexible boom. The experiment incorporates both science (x-ray imaging) and technology (structural system identification and control) objectives and is similar in design to a future space station payload, the Pinhole Occulter Facility. RAMS would provide displacement data for both the boom and the mask to support on-orbit modal tests, disturbance isolation, closed loop tests of the controller, and active structural control of the structure during astrophysics activities.

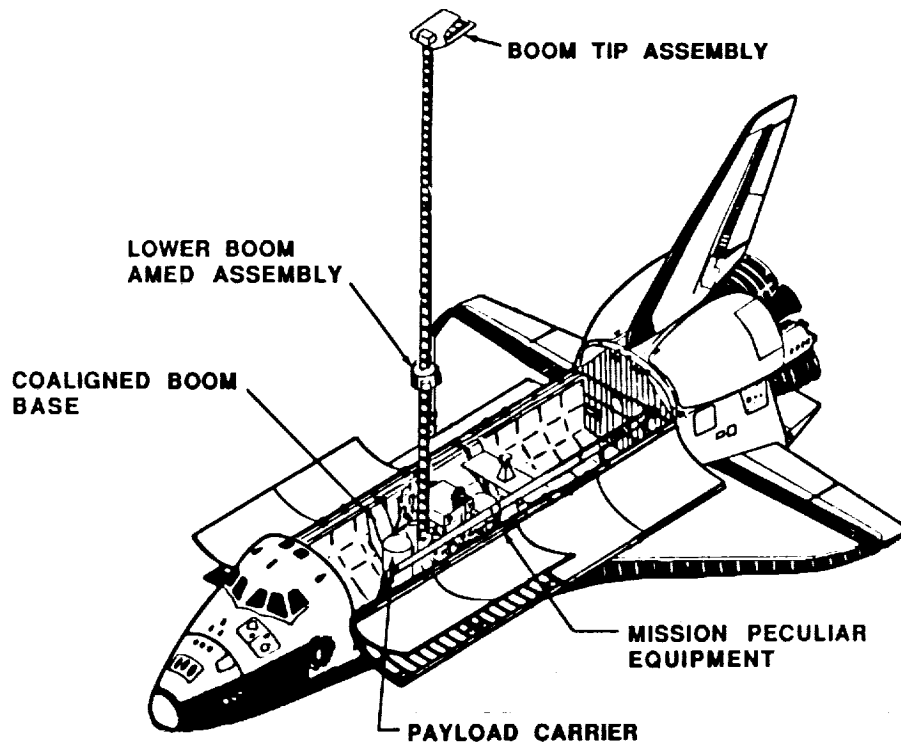

DISPLACEMENT SENSING WITH RAMS

This figure illustrates how RAMS could be used to measure the structural shape of the CASES boom and the orientation of the mask. Two single-axis sensors mounted orthogonally on the base (as shown) can provide X and Y displacement data within an accuracy of 0.0025 in. for targeted locations along the boom. If we assume that the last two targets on the upper end of the boom are linear, normal to the mask, and adequately spaced (e.g., 3 ft), then we can determine the inclination of the mask within 15 arcseconds. Although not illustrated here, the twist of the mask about the Z axis can also be measured within 15 arcseconds by using the two targets mounted on the lower side of the mask, provided they are located at least 3 ft from the center of the boom. The displacement data can be processed with shape algorithms followed by control algorithms to produce command signals for actuators that ultimately control the structural shape and orientation of the CASES experiment.

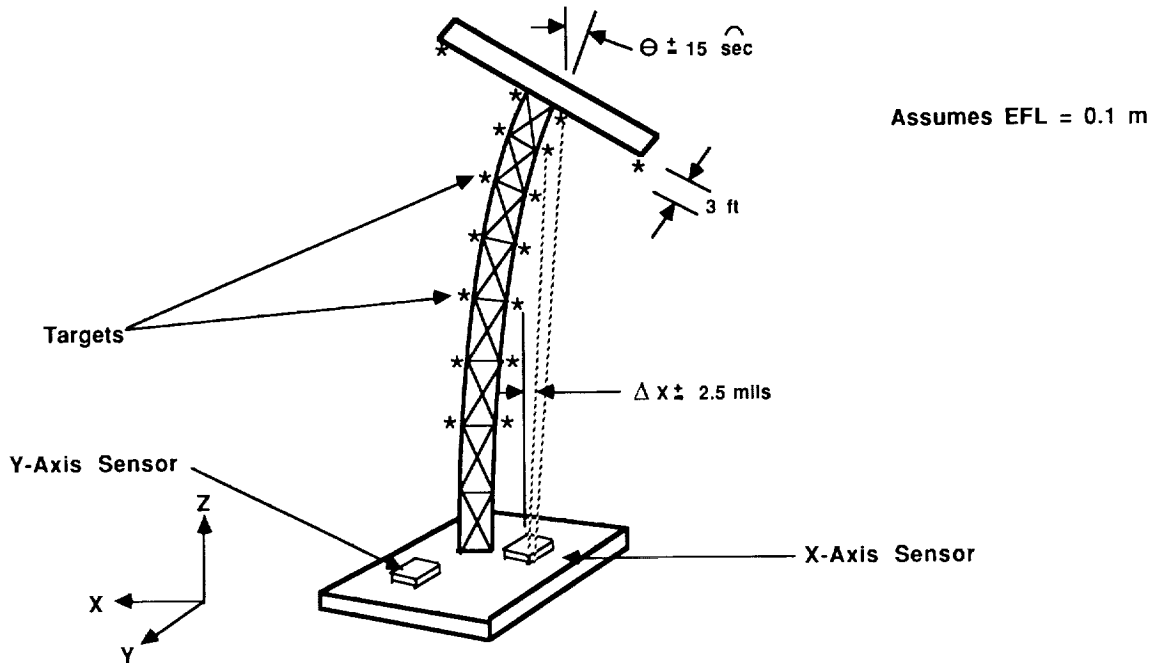

MEASURING SURFACE FIGURE OF REFLECTORS

The surface figure or shape of a reflector can be defined by the elevation angle ϕ for each point along any given cross-section, provided that the reflector materials are dimensionally stable (i.e., they do not stretch). Under these conditions, the performance of the reflector (expressed as 3dB beamwidth half-angle, β) is a function of the wavelength (or frequency) and the diameter of the reflector.

$$\text{3dB beamwidth half-angle } \beta = \frac{7 \times 10^4}{fD} \quad (\text{deg})$$

where f = frequency (MHz)
 d = diameter (ft)

For a 20 GHz parabolic reflector with 49.2 ft diameter and 24.6 ft focal length, β is 0.071 deg. If the angle ϕ for the most extreme target is 20 deg, and if surface displacement at the extreme target $(\Delta r)_{\text{MAX}}$ is $\frac{\lambda}{10}$ alignment sensor like RAMS mounted at the center of the reflector would require only a 1:2,000 resolution to sense such a displacement. This is well within the 1:100,000 resolution capability of RAMS.

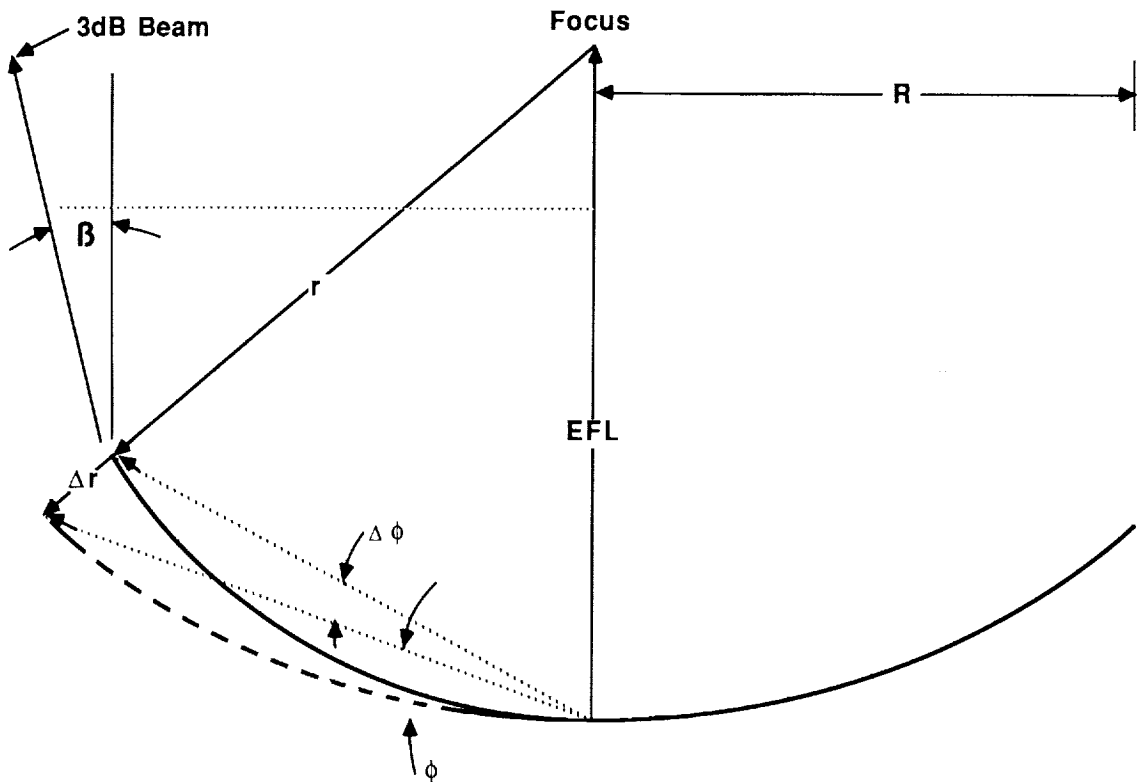

SCANNING CONCEPT FOR RAMS

This figure illustrates one scanning concept that might be used with large reflectors. One linear CCD can provide the radial field-of-view shown at the bottom of the figure and scan surface targets attached at selected points along each rib or segment of the reflector. A second linear CCD, mounted orthogonally to the first, can provide axial sensing of targets along the line of sight of the reflector. This second sensor could provide both feedhorn position relative to the reflector and verification of axial alignment of the scanning mechanism. Several options have been considered for the method of scanning. One is to physically rotate the sensor head with an axial gimbal and transfer power and data across the rotating interface with slip rings. A preferred option is one that uses a rotating prism mounted above the stationary sensor head to achieve scanning. This second option adds complexity to the optical and mechanical design but results in a less expensive and more reliable design.

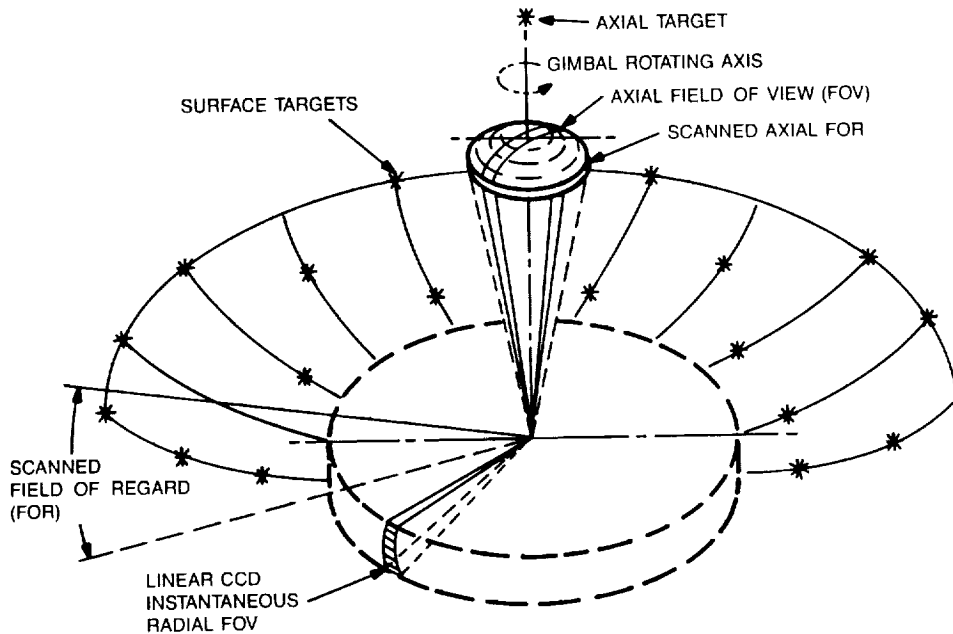

RAMS DESIGN DRIVERS

Each RAMS application is unique, and generally requires a unique optical configuration for optimal performance. However, the electronics circuitry is standard for all applications, provided the current performance limits for accuracy, update rate, and number of targets are sufficient. At the present time, the requirements of most applications can be satisfied with a 1-arcsecond accuracy, 250 Hz update rate, and up to 100 targets. Other design drivers are listed in the table below. Geometry requirements can usually be accommodated. Target selection, radiometry considerations, and background illumination may require innovative approaches, such as pulsed laser diode targets, diffuse target backgrounds, etc. The dynamic behavior of the structure will define displacement characteristics and influence target design. Physical and resource requirements should not be a significant constraint. Based on the RAMS prototype hardware, we expect a single-axis sensor to weigh less than 10 lb and to use less than 20W power.

- **Structure/sensor geometry**
 - Clear line of sight to targets
 - Field of view
 - Depth of field
 - Separation between targets
- **Dynamic behavior of structure**
 - Modal characteristics (frequency, amplitude)
 - Target displacements
 - Target rates
 - Required update rate
- **Number of targets**
 - Target separation
 - Target displacements
- **Physical requirements**
 - Size limitations
 - Weight constraints
- **Active vs passive targets**
 - Unobtrusive sensing
 - Weight constraints
 - Lead-wire interference
 - Radiometry considerations
 - Background illumination
 - Stray light or reflections
- **Resource requirements**
 - Power requirements
 - Data I/F requirements
 - Thermal requirements

SUMMARY

RAMS offers a low-cost, low-risk, proven design concept that is based on mature, demonstrated space sensor technology. The electronic design concepts and interpolation algorithms have been tested and proven in space hardware like the Retroreflector Field Tracker and various star trackers. The RAMS concept is versatile and has broad applicability to both ground testing and spacecraft needs. It is ideal for use as a precision laboratory sensor for structural dynamics testing. It requires very little set-up or preparation time and the output data is immediately usable without integration or extensive analysis efforts. For on-orbit use, RAMS rivals any other type of dynamic structural sensor (accelerometer, lidar, photogrammetric techniques, etc.) for overall performance, reliability, suitability, and cost. Widespread acceptance and extensive usage of RAMS will occur only after some interested agency, such as OAST, adopts the RAMS concept and provides the funding support necessary for further development and implementation of RAMS for a specific program.

- **RAMS offers a proven design concept based on mature, demonstrated technology**

- **RAMS has broad applicability to both ground testing and spacecraft needs:**
 - Precision lab sensor
 - On-orbit system identification
 - Structural characterization
 - Active control feedback
 - Alignment/attitude transfer

- **Further development efforts and funding support are needed to satisfy specific applications and objectives**

REFERENCES

1. Studer, P.A.; Davis, H.W.: Quiet Structures For Precision Pointing. NASA/DOD Control/Structures Interaction Technology Conference (Colorado Springs, Colorado), November 1987.
2. Garibotti, J.F.: Industry Overview/Issues. NASA/DOD Control/Structures Interaction Technology Conference (Norfolk, Virginia), November 1986.
3. Wargocki, F.E.; Ray, A.J.; Hall, G.E.: Retroreflector Field Tracker, State-of-the-Art Imaging Arrays and Their Application. Keith N. Prettyjohns, Editor, Proc. SPIE 501, p. 283.
4. Schock, R.W.: Solar Array Flight Dynamic Experiment. AAS Guidance and Control Conference (Keystone, Colorado), February 1-5, 1986.