

Field Oriented Control of Induction Motors

Linda M. Burrows
Lewis Research Center
Cleveland, Ohio

Don S. Zinger
University of Akron
Akron, Ohio

and

Mary Ellen Roth
Lewis Research Center
Cleveland, Ohio

Prepared for the
25th Intersociety Energy Conversion Engineering Conference
cosponsored by the AIChE, SAE, ACS, AIAA, ASME, and IEEE
Reno, Nevada, August 12-17, 1990



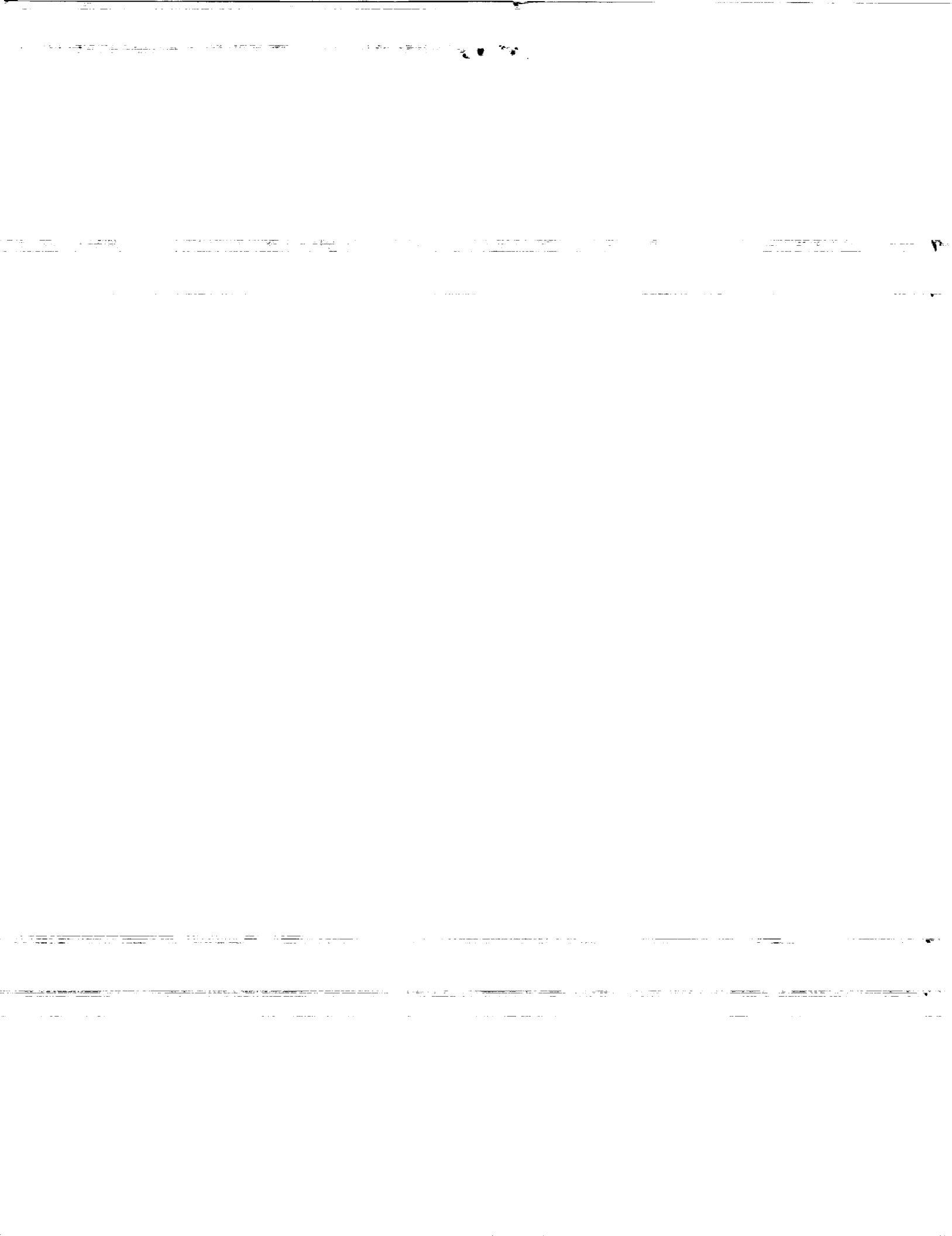

FIELD ORIENTED CONTROL OF INDUCTION MOTORS

Linda M. Burrows

NASA Lewis Research Center
Cleveland, Ohio 44135

Prof. Don S. Zinger

University of Akron
Dept. of Electrical Engr.
Akron, Ohio 44325

Mary Ellen Roth

NASA Lewis Research Center
Cleveland, Ohio 44135

ABSTRACT

Induction motors have always been known for their simple rugged construction, but until lately were not suitable for variable speed or servo drives due to the inherent complexity of the controls. With the advent of field oriented control (FOC), however, the induction motor has become an attractive option for these types of drive systems. At NASA Lewis Research Center, we are currently working with an FOC system which utilizes the pulse population modulation method to synthesize the motor drive frequencies. This system allows for a variable voltage to frequency ratio and enables the user to have independent control of both the speed and torque of an induction motor. A second generation of the control boards have been developed and tested at NASA with the next point of focus being the minimization of the size and complexity of these controls. Many options have been considered with the best approach being the use of a Digital Signal Processor (DSP) due to its inherent ability to quickly evaluate control algorithms. This paper will discuss the present test results of the system and the status of the optimization process using a DSP.

1. INTRODUCTION

This paper will briefly discuss the state-of-the-art (SOA) in Electromechanical Actuation (EMA) technology and its limitations. It is these limitations that have lead us to select resonant power processing and induction motors as the building blocks for our EMA system. A detailed description of the 5 Hp induction motor controller (resident at NASA Lewis) will be presented. Included in this description will be an explanation of an optimized field oriented control of the motor. This leads to a discussion on how to optimize and minimize the control circuitry. The effort in progress at Lewis proposes the use of a Digital Signal Processor to implement the control algorithms for servo control of the motor.

2. BACKGROUND

The SOA in Electromechanical Actuation (EMA) technology has been the dc brushless motor (ac permanent magnet motor) driven by of a switched-mode power processor. Most drivers that have been built for dc brushless motors are for low power applications and the

electronics do not scale up readily. As a result, the dc brushless EMA technology is inadequate for thrust vector control (TVC) and other large vehicle applications with high power requirements. In fact, when compared with hydraulics, this technology has failed to compete. In a switched mode power processor, a pulse width modulation (PWM) technique is used to synthesize machine frequency waveforms from a dc link. All operations are performed at this low (machine) frequency. If the frequency is raised, the turn off switching losses grow proportionately. Also, the energy to be switched tends to increase as the square of the current. At the high power levels required for TVC applications, this results in a driver with unacceptable thermal loads and a reduced efficiency characteristic. Such a driver will usually be many times larger (and heavier) than the motor, making it an undesirable technology choice for a TVC application where weight and size are critical factors.

Other drawbacks of this technology include the inherent limitations of a dc brushless motor. It has a limited torque per ampere capability when compared to other motors. In addition, the permanent magnetic material limits the thermal capability of the motor to below 150° C. The desired motor for a TVC application, however, should have a high torque per ampere capability as well as being rugged in design, capable of high temperature (> 200° C) operation.

It is these inherent limitations in the dc brushless EMA technology that have lead us to pursue induction motors and resonant power processing. We believe there are marked advantages in both the motor and resonant processing. With resonant power processing, a pulse population modulation (PPM) technique is used to synthesize the machine frequency waveforms from a high frequency link. All the switching is done at the voltage zero-crossing, thereby reducing the switching losses. The losses in this driver are then principally the result of the voltage drop across the switching element. In addition, all switching is performed at the carrier (20 kHz) frequency which results in small filter elements. With a resonant circuit topology, the driver can be scaled up to achieve the higher power levels required for TVC and other control surface applications. By selecting high current semiconductor switches such as the newly developed MOSFET Controlled Thyristor (MCT), which has a low forward voltage drop, the size of the motor driver will be comparable to the size of the motor.

The selection of the motor is equally as important as selecting the correct circuit topology for the motor drive. The motor chosen should be sensitive to the requirements of the particular application. For TVC applications, the

demands on the power system are moderate for the duration of most of the mission. Peak demands, on the order of a few seconds, are required for the balance of the mission time. The motor best suited for this application is one that is capable of meeting the peak demands, yet not be oversized (oversized) for the moderate demands which make up greater than 95% of the duty cycle. For this, an induction motor is the best choice. It has a greater torque per amp capability than other motors and can deliver torques in excess of five times its nominal rating for short periods of time (several seconds). It can be operated at higher temperatures ($> 200^{\circ}\text{C}$), since there are no magnets. The induction motor is more rugged, smaller and lighter than a dc brushless motor for a given peak power output [1]. The drawback of this motor has always been the difficulty in controlling it. This, however, is no longer the case. With the electronics available today servo control of an induction motor is easily accomplished through FOC techniques.

3. 20 kHz MOTOR DRIVE SYSTEM

At NASA we are currently developing a 20 kHz induction motor drive system (built in part by General Dynamics Space Systems Division), which was first demonstrated at the University of Wisconsin and then transferred to NASA [2]. This motor driver integrates a high frequency link, PPM, and an induction motor with a field oriented control scheme, shown in figure 1. The pulse-population modulation converts a 20 kHz single phase input into a 3-phase low frequency output to drive induction motors. The PPM method selects individual pulses of the 20 kHz voltage to produce the machine frequency waveform, as shown in figure 2 [3]. The amplitude (voltage) is determined by the density (population) of the pulses while the frequency is determined by the actual waveform pattern. This type of modulation enables the independent control of both voltage and frequency. Our system has been tested to 2000 Hz and currently is controlling a 400 Hz 208 volt off-the-shelf induction motor.

The induction motor can be controlled in either a voltage or current regulation mode. The voltage mode is directly controlled by an external programmable controller while the current mode is accomplished with the FOC boards. The current mode uses rotor speed feedback information to create a closed loop control system. In this mode, the speed control board allows control of the torque command within microseconds. A maximum torque change command can be sent causing the motor to reverse direction over the full speed range very rapidly. This is important for the TVC applications. For TVC, quick direction reversals are imperative which are possible with the FOC design.

The block diagram for the entire FOC system is shown in figure 3. The speed control board takes the speed and rotor feedback information and generates the torque command current, i_q . The i_q and manually commanded flux current, i_m , are processed by the remaining FOC boards to generate the desired phase current reference commands. These commands are then sent to the regulator which compares the reference commands with feedback currents to produce an error signal. This error is used to generate the gate drive signals for the PPM converter.

4. OPTIMIZATION TECHNIQUES

Optimization of the motor drive system is being attempted by two separate means in order to improve the system operation. An advanced motor control technique is being evaluated to improve efficiency. For increased system reliability, the complexity of the control circuitry is being addressed. A detailed discussion of both techniques follows.

Optimized control of the motor is essential in order to develop an EMA system that is as efficient as possible. The limit is (and probably always will be) the electronics. Even using resonant power processing, the capability of the driver electronics is still the limiting factor for these systems at these power levels. It is, therefore, advantageous to always operate the motor at its most efficient point. The advanced motor control technique being investigated is the varying of the v/f ratio to obtain the maximum efficiency for any load condition. Figure 4 shows plots of typical motor data. With the v/f control, the curves can be moved left, right, up or down to operate the motor at its most efficient point for any load at any speed. Initial tests were run at the University of Wisconsin and the results can be seen in figure 5 [2]. This shows that by decreasing the v/f ratio (or flux), higher efficiencies can be obtained at lower torques. We are in the process of running tests to completely map efficiency versus torque and speed curves for various loads. These curves will help determine the optimum operating condition for any load applied. Control programs can then be developed to operate the motor at its highest efficiency at all times.

The minimization of the complexity and size of the controls to increase system reliability has also been studied. After evaluation of a number of minimization techniques, a Digital Signal Processor (DSP) has been chosen due to the built-in capability to quickly evaluate control algorithms. DSP's have been specially designed to process the large amount of data generated by a system in a relatively short period of time. Due to their high speeds, DSP's have made their way into many control applications. The DSP can be thought of as a microprocessor designed to do high speed calculations. Based on a highly pipelined architecture, the control algorithms are able to exploit the parallelism inherent in the DSP [4]. DSP's are designed to quickly evaluate addition and multiplication functions which can further increase the speed of the tasks they are designed to perform.

Many of the algorithms used in the control of electric machines are well suited for this specialized architecture. The algorithms generally consist of repetitive calculations with little branching. They require numerous multiplications to be done quickly for real time control. Because of the close match between the algorithms used in FOC and the calculation ability of the DSP, these integrated circuits have quickly made their way into field orientation applications. DSP's have been shown to perform the field orientation calculations in the range of 30 to 35 microseconds [5,6].

Although FOC systems are capable of rapid torque control, most are not complete motor controllers. They take in torque and flux commands and output either current commands or switching states to a separate circuit which generates gate drive signals. Generally motor controllers also require a speed or position input. With most implementations, including NASA's, this is taken care of by external devices such as an encoder. To include the entire motor control in a DSP would considerably increase the

execution time. One system which included a total control from speed input to gate signal outputs, shown inside the dashed line in figure 6, was capable of operating at a maximum of 4 KHz switching speed [7]. For our system, a decision on switching pulses occurs every 25 microseconds. Since this time is close to the calculation period for typical field oriented calculations, there would be little time remaining for other operations. With the presently available processors, it may not be feasible to implement the entire motor control.

While waiting for the inevitable faster processor, the speed requirements of the processor can be greatly reduced by allowing a separate circuit to generate the gate signals. In such a system, the processor will only be required to perform calculations quickly enough to maintain a reasonable current waveform. In our three phase system, this requires a minimum of 6 updates at the highest frequency of operation [8]. For this 400 hz motor operating at twice its rated speed, this will require an update speed of at least 4800 hz. Such speeds are obtainable with present DSP technology.

A block diagram of the proposed DSP system is shown in figure 6. The system input will be a digital speed reference from the user. The DSP will also require an encoder input to determine the actual speed of the motor. The DSP will output the desired current commands which are converted to analog signals and compared with actual current feedbacks. This will produce the error signals needed to generate correct gate drive signals.

The field orientation scheme being used is an indirect type shown in figure 7. The control requires the calculations for speed regulation, coordinate transformation, and additional multiplications and divisions. Assuming a typical proportional-integral control, the calculation requirement will include several multiplications and an integration. The coordinate transformation calculations will require lookup tables and multiplications. Many of these operations can be performed in one instruction cycle (typically less than 200 ns for present day DSPs). Estimates for some longer calculation times are summarized in table 1. These estimates are based on the TMS320C14 cycle time of 160 ns and standard routines for similar operations. It is estimated that the total processing time will be less than 30 microseconds. This is considerably less than the maximum allowed time between current updates (approximately 200 us). The DSP, therefore, is expected to perform adequately and minimize the additional hardware required with the original FOC implementation.

5. PROPOSED IMPLEMENTATION

The current hardware in use at NASA performs 5 major functions. They are the speed control, the slip calculation, the angle calculation, the coordinate transformation, and the two to three phase conversion. With the present hardware implementation each of these functions is essentially performed on a separate board, although some functions overlap. With the DSP, each function is capable of being performed by relatively simple algorithms in a few lines of code.

The speed control of the present system performs a proportional-integral control upon the error between the commanded speed and the actual speed. The present analog board could easily be replaced with a few lines of code performing a simple trapezoidal integration and a few

multiplications. An example of a high level pseudo code for this implementation would be:

```
SPEED_ERR = SPEED - SPEED_COMMAND
INT_ERR = (SPEED_ERR + OLD_ERR) *
          TIME_STEP/2 + INT_ERR
IQS_COMMAND = KP * SPEED_ERR + KI * INT_ERR
OLD_ERR = INT_ERR
```

The slip calculator determines the desired slip for a given torque and flux command. This is performed in software by using the relationship between the torque producing current, flux producing current, and the slip required for FOC. Pseudo code for this calculation is:

$$SLIP_COM = (IQS_COMMAND/IDS_COMMAND)/TR$$

where TR is the equivalent rotor time constant.

The angle calculator finds the present angle required for transforming from the synchronous reference frame to the stationary. This is accomplished by adding the slip speed and rotor speed onto the present angle. The scaled value of slip speed can be added every time it is calculated. The rotor speed is determined by the number of pulses received from the encoder. The rotor speed can be added to the present angle by having each encoder pulse interrupt the processor to perform the calculation. Special code will keep track of clockwise or counter-clockwise calculation.

The calculated angle is used to transform the current commands from the synchronous coordinates used for calculation to the stationary coordinates needed by the current regulator. This is done by using the values found in a lookup table for the sine and cosine of this angle and applying them to standard reference frame transformations. The pseudo code for this operation is:

```
SINX = SIN(ANG)
COSX = COS(ANG)
IQSS = IQS_COMMAND * COSX + IDS_COMMAND * SINX
IDSS = IQS_COMMAND * SINX + IDS_COMMAND * COSX
```

Once these are calculated, the two phase Q and D current commands need to be converted to three phase ABC current commands. This is done using standard conversion. The pseudo code for these conversions is:

```
IAS_COMMAND = IQSS
IBS_COMMAND = -IQSS/2 - SQRT(3) * IDSS/2
ICS_COMMAND = - (IAS_COMMAND + IBS_COMMAND)
```

Some steps can be saved when doing the calculations by combining the coordinate reference transformation and the two to three phase transformation.

It should be noted that each of these lines of pseudo code will take several lines of assembly language. The final result, however, will be a program of a size that is easily managed. The DSP system will allow our high performance FOC to be implemented with less hardware than the present construction. This will compact the system and thus increase its reliability.

6. CONCLUSION

While ongoing effort is being made to optimize NASA's 20 kHz motor drive system, it has already been shown that the system will exceed performance of conventional PWM motor drive technologies. Once completed the system will be advantageous in areas such as size, weight, and efficiency, which are critical parameters for EMA applications.

7. REFERENCES

- [1] Dr. T. Kume, "Wide Constant Power Range Vector-Controlled AC Motor Drive Improves Spindle Drives," Power Convers. Intel. Motion, pp 59-66: April 1990.
- [2] Thomas A. Lipo, et. al., "Testing and Modification of the General Dynamics Converter", NASA Contractor Report, No. NAG3-786, pp 51-52: Sept. 1988.

[3] P. A. Sood, T. A. Lipo, and I. G. Hansen, "A Versatile Power Converter for High Frequency Link Systems," IEEE Trans. Power Electronics, vol. 3 no. 4, pp 383-390: Oct. 1988.

[4] A. Jonathan, "Computer Architecture of Digital Signal Processors," Proceedings of IEEE, pp 853-873: May 1985.

[5] R. W. DeDonker, and D. W. Novotny, "The Universal Field Oriented Controller," Conference Record of the IEEE IAS Annual Meeting, pp 450-456: 1988.

[6] T. G. Habetler and D. W. Novotny, "The Universal Field Oriented Controller," Conference record of the IEEE IAS Annual Meeting, pp 514-522: 1989.

[7] X. Xu, and D. W. Novotny, "Bus Utilization of Discrete CRPWM Inverters for Field Oriented Drives," IEEE IAS Annual Meeting, pp 362-367: 1989.

[8] R. D. Lorenz, "Controller Considerations for High Performance AC Drives," Introduction to Field Oriented and High Performance AC Drives, D. W. Novotny and R. D. Lorenz eds., IEEE, New York: 1985.

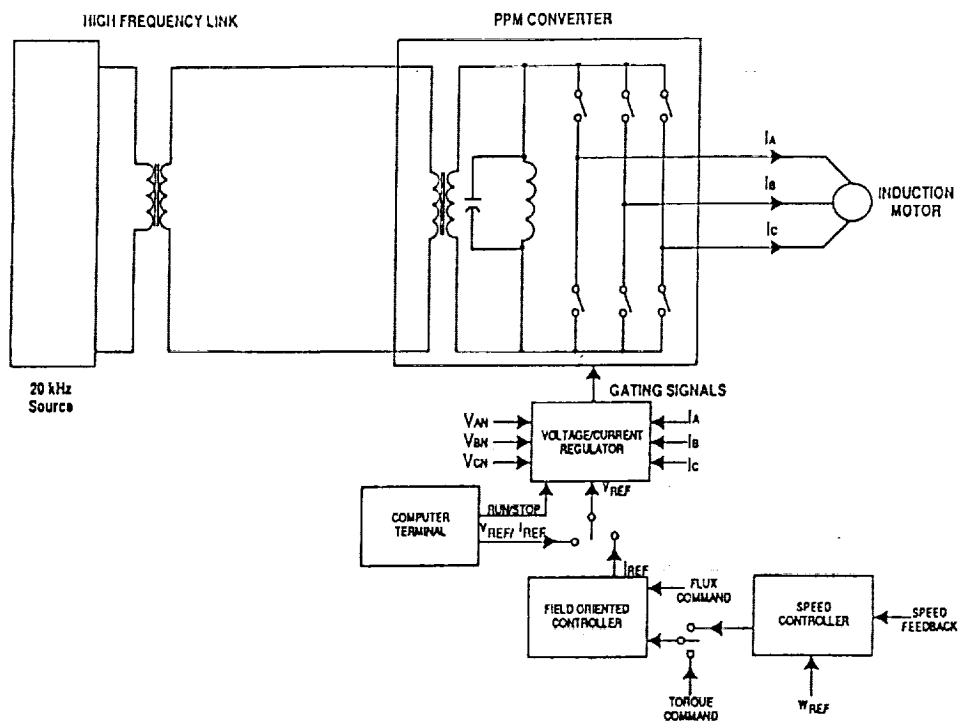

Figure 1. Diagram of 20 KHz Motor Drive System

ORIGINAL PAGE IS
OF POOR QUALITY

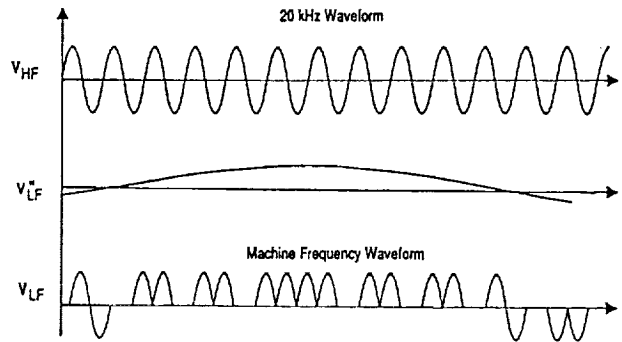

Figure 2. Modulation Technique to Produce Machine Frequency Waveform

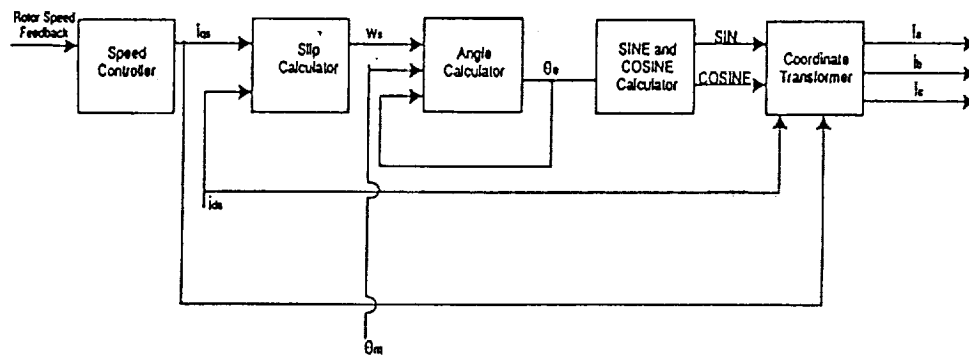

Figure 3. Block Diagram of FOC

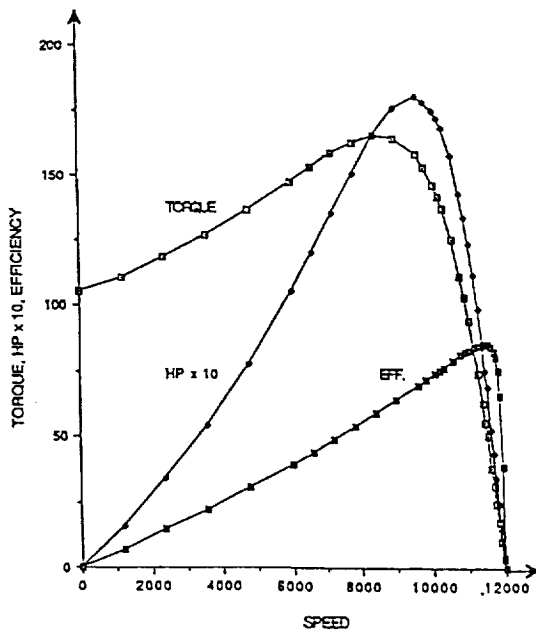

Figure 4. Typical Induction Motor Curves

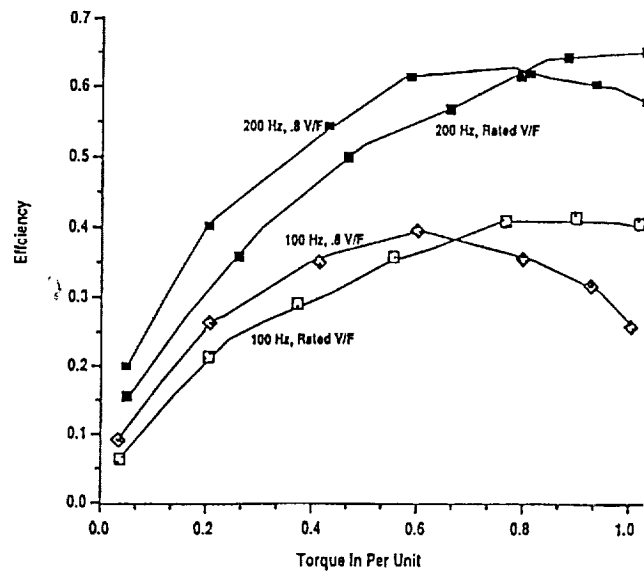

Figure 5. Plot of Efficiency vs. Torque for Varying V/F (200 Hz and 100 Hz Operation)

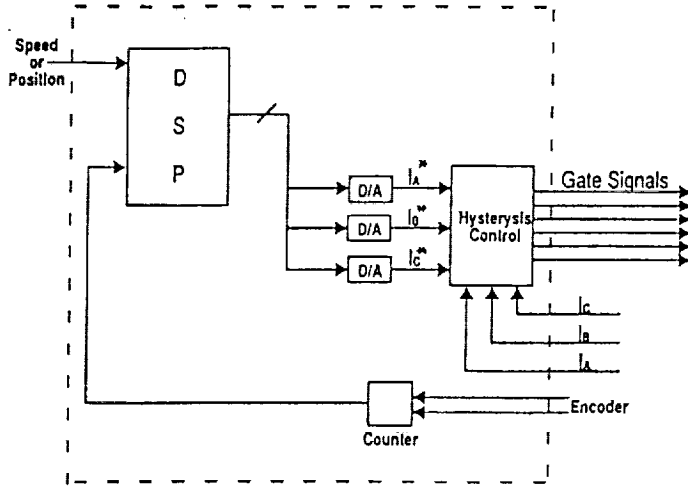

Figure 6. Block Diagram of Speed Control System (Dashed Block Represents A DSP Which Would Contain an Entire Motor Control System)

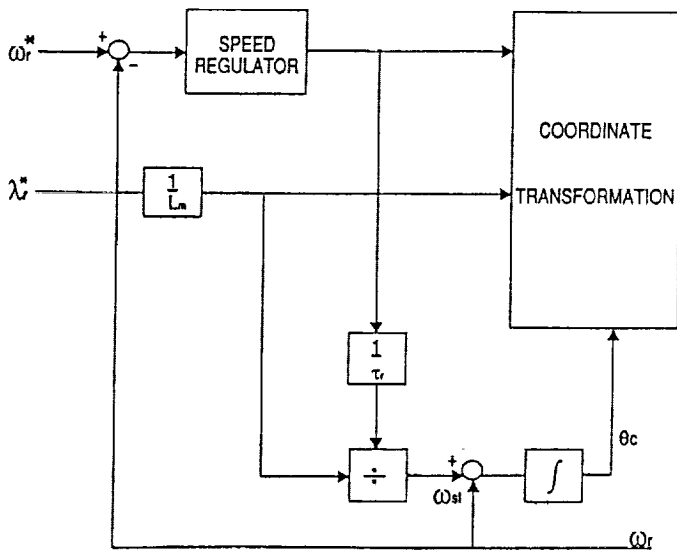

Figure 7. Detailed Diagram of FOC Scheme.

FUNCTION	TIME (μs)
PI CONTROL	1.4
COORDINATE TRANSFORMATION	1.9
DIVISION	5.8

Table 1. Estimates of Function Processing Time



Report Documentation Page

1. Report No. NASA TM-103154		2. Government Accession No.		3. Recipient's Catalog No.	
4. Title and Subtitle Field Oriented Control of Induction Motors				5. Report Date	
				6. Performing Organization Code	
7. Author(s) Linda M. Burrows, Don S. Zinger, and Mary Ellen Roth				8. Performing Organization Report No. E-5516	
				10. Work Unit No. 946-02-20	
9. Performing Organization Name and Address National Aeronautics and Space Administration Lewis Research Center Cleveland, Ohio 44135-3191				11. Contract or Grant No.	
				13. Type of Report and Period Covered Technical Memorandum	
12. Sponsoring Agency Name and Address National Aeronautics and Space Administration Washington, D.C. 20546-0001				14. Sponsoring Agency Code	
				15. Supplementary Notes Prepared for the 25th Intersociety Energy Conversion Engineering Conference cosponsored by the AIChE, SAE, ACS, AIAA, ASME, and IEEE, Reno, Nevada, August 12-17, 1990. Linda M. Burrows and Mary Ellen Roth, NASA Lewis Research Center. Don S. Zinger, University of Akron, Department of Electrical Engineering, Akron, Ohio 44325.	
16. Abstract Induction motors have always been known for their simple rugged construction, but until lately were not suitable for variable speed or servo drives due to the inherent complexity of the controls. With the advent of field oriented control (FOC), however, the induction motor has become an attractive option for these types of drive systems. At NASA Lewis Research Center, we are currently working with an FOC system which utilizes the pulse population modulation method to synthesize the motor drive frequencies. This system allows for a variable voltage to frequency ratio and enables the user to have independent control of both the speed and torque of an induction motor. A second generation of the control boards have been developed and tested at NASA with the next point of focus being the minimization of the size and complexity of these controls. Many options have been considered with the best approach being the use of a Digital Signal Processor (DSP) due to its inherent ability to quickly evaluate control algorithms. This paper will discuss the present test results of the system and the status of the optimization process using a DSP.					
17. Key Words (Suggested by Author(s)) Induction motors Field oriented control Digital signal processors			18. Distribution Statement Unclassified - Unlimited Subject Category 33		
19. Security Classif. (of this report) Unclassified		20. Security Classif. (of this page) Unclassified		21. No. of pages 8	22. Price* A02

