



National Aeronautics and
Space Administration

Washington, D.C.
20546

580743 PAT APPL
P. 10
IN-37
597640
P-10

Reply to Attn of:

NOTICE

The invention disclosed in this document resulted from research in aeronautical and space activities performed under programs of the National Aeronautics and Space Administration. The invention is owned by NASA and is, therefore, available for licensing in accordance with the NASA Patent Licensing Regulation (14 Code of Federal Regulation 1245.2).

To encourage commercial utilization of NASA-owned inventions, it is NASA policy to grant licenses to commercial concerns. Although NASA encourages nonexclusive licensing to promote competition and achieve the widest possible utilization, NASA will consider the granting of limited exclusive license, pursuant to the NASA Patent licensing Regulations, when such license will provide the necessary incentive to the licenses to achieve early practical application of the invention.

Address all inquires and application for license for this invention to NASA Patent Counsel, Langley Research Center, Mail Code 279, Langley Sration, Hampton, VA 23665. Approved NASA forms for application for nonexclusive or exclusive license are available from the above address.

(NASA-Case-LAR-14142-1) SUSPENSION
MECHANISM AND METHOD Patent Application
(NASA) 10 p CSCL 13I

N90-27116

Unclas

G3/37 0297640

SUSPENSION MECHANISM AND METHOD

NASA Case No. LAR 14142-1

AWARDS ABSTRACT

The invention is a suspension mechanism and method for suspending flexible structural members subjected to large horizontal and vibratory motions. A novel feature is the combined use of a ZSRM between two air bearings to permit six degrees of freedom of motion of the test structure that are unconstrained by the suspension mechanism.

This unique design provides a relatively small suspension device adaptable for use in many laboratories in which such testing could not be performed using known suspension mechanisms.

Inventors: Stanley E. Woodard
Address: 51F Waters Edge
Newport News, VA 23606
SS#: [REDACTED]

Victor M. Cooley
11 Morning View Court
Hampton, VA 23664
SS#: [REDACTED]

Employer: NASA Langley Research Center
Initial Evaluator: Robert J. Hayduk

Serial No.: 07/473,030
Filed: January 31, 1990

LAR 14142-1

-1-

PATENT APPLICATION

SUSPENSION MECHANISM AND METHOD

Origin of the Invention

5 The invention described herein was made by employees of the United States Government and may be manufactured and used by or for the Government for governmental purposes without the payment of any royalties thereon or therefor.

10 Background of the Invention

1. Field of the Invention

15 The invention is a suspension mechanism and method and more particularly such a mechanism and method for suspending flexible mass critical articles such as lightweight spacecraft structures undergoing large motions such as slewing, translation and telescoping/retraction.

2. Description of the Prior Art

20

 Known devices for suspending objects include cable suspension, air bags, air bearings, and cables with zero-spring-rate mechanisms (ZSRM). These devices are not designed for nor capable of suspending structures undergoing large horizontal and vibratory motion concurrently while permitting
25 six degrees of freedom of substantially unconstrained motion.

Summary of the Invention

30 An object of the invention is to provide a mechanism and method for suspending test structures such as flexible spacecraft subjected to both large horizontal and vibratory motions while reducing the interaction between the motion of the test structure and the suspension mechanism.

Another object is to provide a mechanism and method of suspending such test structures that reduces the effects due to friction, non-linearity and mass coupling between the suspension mechanism and the suspended structure thus permitting six degrees of freedom of substantially unconstrained motion of the test structure.

These and other objects are achieved by the invention which includes a ZSRM 11 mounted on a first translational air bearing means 12 for vertically supporting the ZSRM relative to a work table 13 on a first air cushion A-1 and unconstrained by friction between and as a result of relative horizontal movement between the two. A second semi-spherical air bearing means 14 for supporting the test structure T_s on a second air cushion A-2 is affixed to a coupling rod 17 arranged to reciprocate vertically in bearings 25 and 26 in response to forces exerted by the test structure T_s against a prestressed positive spring 18 in the ZSRM 11, the effective stiffness or resistance to vertical movement of the ZSRM 11 being determined by adjustable non-linear springs 31 and 32 in said ZSRM 11 attached to the coupling rod 17.

The invention permits both unlimited horizontal rigid-body translational motion unconstrained by frictional resistance and unconstrained but limited vertical motion of the test structure T_s . The remaining two additional degrees of freedom of motion are unconstrained by the second air bearing means 14. Thus the invention reduces the interaction between the suspension mechanism and test structure T_s permitting its substantially unconstrained horizontal and vibratory motion.

25

Brief Description of the Drawings

The above and numerous other objects and advantages that may be achieved by the method and a preferred embodiment of the mechanism in accordance with the invention will become apparent from the following detailed description when read in view of the appended drawings wherein:

30

FIG. 1 is a side elevational view in cross-section illustrating a preferred embodiment of the invention; and

FIG. 2 is a force diagram illustrating the operating principles of the invention shown in FIG. 1.

5

Brief Description of the Invention

Referring to the drawing, FIG. 1 illustrates a preferred embodiment of the invention as generally comprising a conventional zero-spring-rate mechanism (ZSRM) generally designated by the reference numeral 11. A first translational air bearing means 12 provides a first air cushion A-1 that supports the ZSRM 11 on and relative to a table 13, permitting movement of the ZSRM 11 over the surface of table 13 without frictional resistance. A second air bearing means 14 provides a second air cushion A-2 for supporting a test structure T_s to be subjected to horizontal and vertical motion forces. A coupling rod 17 interconnects the second air bearing means 14 and a positive spring 18 in the ZSRM 11 that exerts a positive upward stiffness force F-1 as shown in FIG. 2.

The ZSRM 11 includes a frame 19 of horizontal and vertical members 20 and 21 attached to parallel rails 22 secured to the first conventional air bearing means 12 which may be a commercially available unit such as an Aero-Caster Load Module, Model K8N manufactured by Aerogo, Incorporated of Seattle, Washington and the operation of which is well known. The first air bearing means 12 is connected to a suitable source of air pressure 23 by supply tube 24 to support the ZSRM 11 on the first cushion of air A-1 on the surface of work table 13. This permits movement of the ZSRM 11 over the surface of work table 13 without frictional resistance. Thus by combining the ZSRM and the first translational air bearing means 12, the suspension mechanism moves horizontally without frictional resistance over the flat surface of work table 13 without interfering with horizontal movements of the test structure T_s . Thus air bearing A-1 permits two degrees of freedom of

unconstrained horizontal motion of the test structure relative to the flat surface of table 13.

The reciprocable coupling rod 17 is mounted in suitable bearings 25 and 26. The end 27 of rod 17 bottoms on the top of the air bearing means 12 to limit its stroke against the positive spring 18. The stroke of the rod
5 may also be limited by the solid height of the spring.

The spring 18 is captured between the bottom frame member 21 and a clamp 29 to which both the prestressed positive spring 18 and rod 17 which passes through both are fixedly attached. The spring 18 exerts an
10 upward positive stiffness or resistance force F_1 , as showing in FIG. 2. Opposing negative non-linear side springs 31 and 32 are attached to opposite sides of clamp 29 at one end and plates 33 and 34 at the other. The plates 33 and 34 are rotatively attached to threaded spring adjustment means 35 and 36 which move the respective plates 33 and 34 horizontally
15 relative to the clamp 29.

Use of the threaded adjustment means 35 and 36 varies the non-linear action of the opposing side springs 31 and 32 to selectively provide an opposing negative vertical of prestressed stiffness force F_2 to the positive force F_1 exerted by prestressed positive spring 18. This controls the effective
20 stiffness or resistance of the ZSRM 11 to the vertical displacement of the coupling rod 17 caused by vertical motions of the suspended test structure T_s attached to a second air bearing means 14 affixed to the extended end 37 of the rod 17. Thus the ZSRM 11 permits two degrees of freedom of substantially unconstrained vertical motion of the test structure T_s .

The second air bearing means 14 which establishes a second air cushion A-2 is powered from the air source 23 through supply tube 38. The air pressure connected to the air bearings 12 and 14 may be selectively varied at the source. Air exits under pressure through outlets 39 in a semi-spherical dish or socket 41 to establish a second air cushion A-2 and support
25 a semi-spherical ball member 42 attached to the test structure T_s . The air cushion A-2 permits frictionless movement of the ball member 42 within the socket 41 caused by movement of the test structure T_s . This is
30

accomplished without effecting the downward force exerted by the second air bearing against the effective opposing positive stiffness force of ZSRM 11. Thus the second air cushion A-2 permits two additional degrees of freedom of unconstrained rotational motion of the structure T_s relative to the flat surface of table 13.

FIG. 2 illustrates the resulting forces F_1 and F_2 relative to the three axes of motion of the test structure T_s when suspended on the ZSRM mechanism 11.

The invention operates on the following principles:

$$M_{\text{system}} q_i + C_{\text{system}} q_i + K_{\text{system}} q_i = 0$$

$$q_i^T = \{x, y, z, \theta_1, \theta_2, \theta_3\}$$

as

$$(K, C, M)_{\text{suspension}} \rightarrow 0, (K, M, C)_{\text{system}} \rightarrow (K, C, M)_{\text{article}}$$

and

$$\text{Dynamics}_{\text{system}} \rightarrow \text{Dynamics}_{\text{article}}$$

K, C, M represent stiffness, damping and inertia properties respectively. The vector q_i consists of translational (x,y,z) and rotational ($\theta_1, \theta_2, \theta_3$) degrees of freedom at the connection between the socket 41 and ball 42 attached to the test structure T_s . It is shown that as the physical properties of the suspension device diminish the physical properties of the test structure T_s dominate the system.

The first air bearing means 12 leaves θ_3 , x, and y unconstrained. ZSRM 11 concurrently reduces the stiffness of the prestressed positive support spring 18 thereby softening the z direction while the second spherical air bearing means leaves θ_1 and θ_2 unconstrained. The summation of the operative forces may be expressed as follows:

30

$F_1 = Kz$, from positive spring

$F_2 = p \sin \phi$, from negative spring

where

z is vertical displacement

5 K is stiffness of positive spring

ϕ is rotation of side spring

p is compressive force due to side springs

$$F_{\text{resultant}} = F_1 - F_2 = 0$$

$$= Kz - p \sin \phi = 0$$

10 For small displacement $\sin \phi = z/l$

l = side spring length

$$F_{\text{resultant}} = (K - p/l) z = 0$$

15 Thus, a unique feature of the invention is its ability to suspend a flexible test structure T_s undergoing large rigid body motion concurrent with vibratory motion with minimal interaction from the mechanism. It is also adaptive for use with active control thus reducing undesirable effects due to friction, non-linearity, and mass coupling.

20 The invention can be small in size compared to most test structures and easily adapted for use in most test facilities. Because no cables are needed as in many conventional systems, overhead clearance is minimal. Thus the invention may be used in most suspension applications.

25 While preferred embodiments have been described in detail numerous changes and modifications can be made within the principles of the invention which is to be limited only by the appended claims.

What is claimed is:

SUSPENSION MECHANISM AND METHOD

Abstract of the Disclosure

5 The invention is a suspension mechanism and method for suspending
a flexible test structure T_s , subjected to large horizontal translational and
vibratory motions. A zero-spring rate mechanism between air cushions A-1
and A-2 established by air bearings 12 and 14 support an end of the test
structure T_s , on a flat surface of table 13 permitting up to six degrees of
10 freedom of motion of the suspended test structure T_s , substantially
unconstrained by the suspension mechanism.

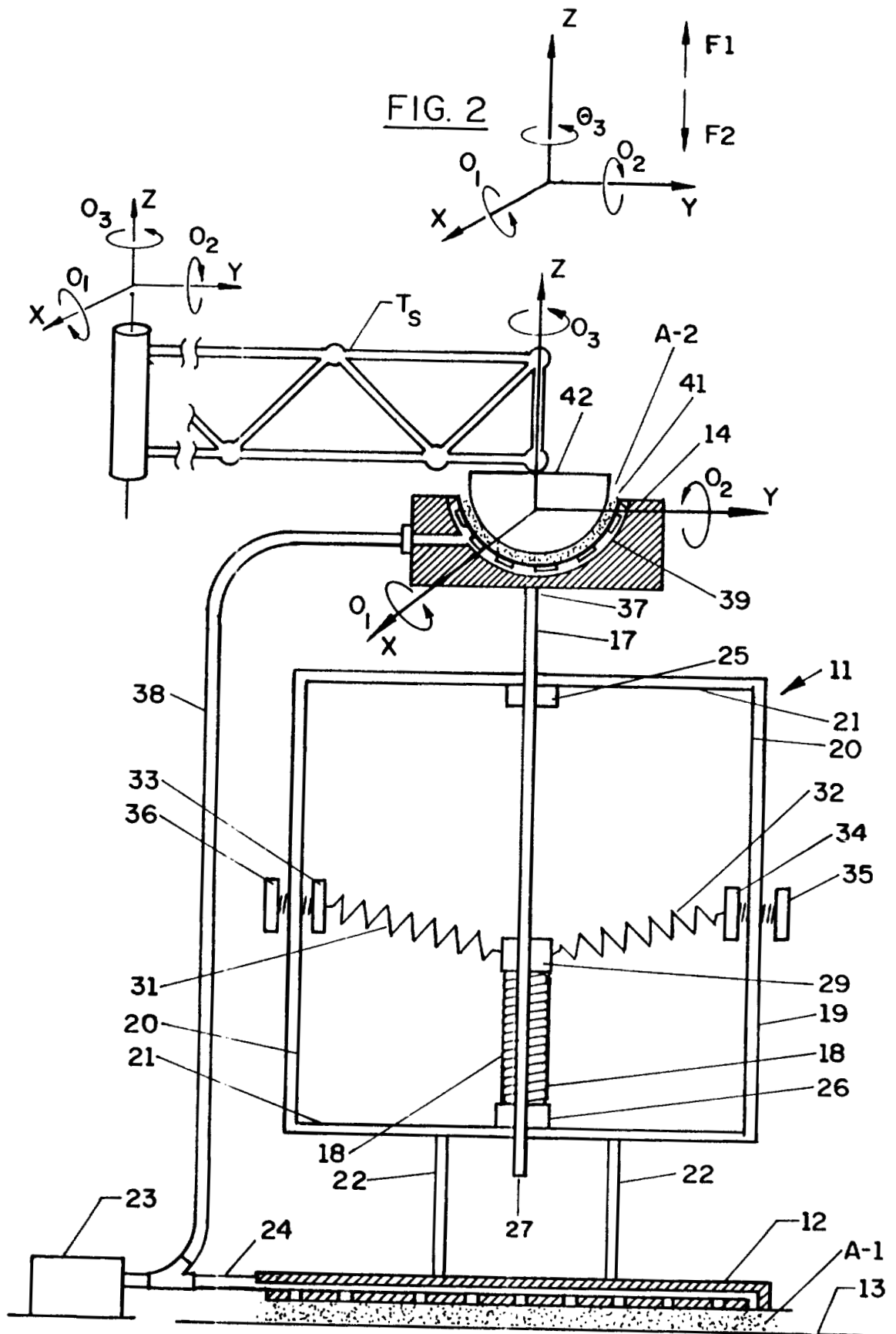

FIG. 1