

**NASA
Technical
Paper
2916**

August 1990

Ceramics Analysis and Reliability Evaluation of Structures (CARES)

Users and Programmers Manual

Noel N. Nemeth,
Jane M. Manderscheid,
and John P. Gyekenyesi

(NASA-TP-2916) CERAMICS ANALYSIS AND
RELIABILITY EVALUATION OF STRUCTURES
(CARES). USERS AND PROGRAMMERS MANUAL
(NASA) 232 p

CSCL 110

H1/39

NDU-2807
unclas
0200256

NASA

**NASA
Technical
Paper
2916**

1990

Ceramics Analysis and Reliability Evaluation of Structures (CARES)

Users and Programmers Manual

Noel N. Nemeth
Aerospace Design & Fabrication, Inc.
Brook Park, Ohio

Jane M. Manderscheid
and John P. Gyekenyesi
Lewis Research Center
Cleveland, Ohio

NASA

National Aeronautics and
Space Administration
Office of Management
Scientific and Technical
Information Division

Trade names or manufacturers' names are used in this report for identification only. This usage does not constitute an official endorsement, either expressed or implied, by the National Aeronautics and Space Administration.

Contents

	Page
Summary	1
Introduction	1
Program Capability and Description	3
Input Information	9
MSC/NASTRAN Finite Element Analysis	9
Executing MSC/NASTRAN	10
Preparation of MSC/NASTRAN Problem for Reliability Analysis With CARES	10
CARES Input File Preparation	12
Master Control Input	12
Material Control Input	14
Material- and specimen-dependent data	14
Temperature-dependent fracture or statistical material parameters data	23
Execution of the CARES Program	24
Output Information	26
MSC/NASTRAN Output Options	26
CARES Output Information	27
Theory	28
Volume Flaw Reliability	29
Surface Flaw Reliability	37
Estimation of Statistical Material Strength Parameters	40
Material Strength Characterization	42
Example Problems	45
Example 1—Transversely Loaded Circular Disk	45
NASTRAN Input File—Solid and Shell Elements	51
NASTRAN Input File—Axisymmetric Elements	62
CARES Templet Input File	68
CARES2 Output File	73
Example 2—Rotating Annular Disk	99
NASTRAN Input File	103
CARES Templet Input File	107
CARES2 Output File	112
Example 3—Statistical Material Parameter Estimation	128
CARES Templet Input File	131
CARES2 Output File	138
Example 4—Thermomechanically Loaded Annular Disk	151
NASTRAN Input File	153
CARES Templet Input File	159
CARES2 Output File	169
Example 5—Shear-Sensitive Calculation of the Batdorf Crack Density Coefficient	189
NASTRAN Input File	191
CARES Templet Input File	201
CARES2 Output File	204
Subroutine Descriptions	213
Appendixes	
A—Symbols	219
B—Glossary of Terms	221
C—CARES.COM	225
References	226

Summary

This manual describes the Ceramics Analysis and Reliability Evaluation of Structures (CARES) computer program. The primary function of the code is to calculate the fast-fracture reliability or failure probability of macroscopically isotropic ceramic components. These components may be subjected to complex thermomechanical loadings, such as those found in heat engine applications. The program uses results from MSC/NASTRAN or ANSYS finite element analysis programs to evaluate component reliability due to inherent surface and/or volume type flaws. A multiple material capability allows the finite element model reliability to be a function of many different ceramic material statistical characterizations. The reliability analysis uses element stress, temperature, area, and volume output, which are obtained from two-dimensional shell and three-dimensional solid isoparametric or axisymmetric finite elements.

CARES utilizes the Batdorf model and the two-parameter Weibull cumulative distribution function to describe the effects of multiaxial stress states on material strength. The shear-sensitive Batdorf model requires a user-selected flaw geometry and a mixed-mode fracture criterion. Flaws intersecting the surface can be modeled as Griffith cracks, Griffith notches, or semicircular cracks. Imperfections embedded in the volume can be described as Griffith flaws, Griffith cracks, or penny-shaped cracks. The total strain energy release rate theory is used as a mixed-mode fracture criterion for coplanar crack extension. Out-of-plane crack extension criteria are approximated by a simple equation with a semi-empirical constant that can model the maximum tangential stress theory, the minimum strain energy density criterion, the maximum strain energy release rate theory, or experimental results. For comparison, Griffith's maximum tensile stress theory, the principle of independent action (PIA), and the Weibull normal stress averaging models are also included.

Weibull material strength parameters, the Batdorf crack density coefficient, and other related statistical quantities are estimated from four-point bend bar or uniform uniaxial tensile specimen fracture strength data. Parameter estimation can be performed for single or multiple failure modes by using the least-squares analysis or the maximum likelihood method. Kolmogorov-Smirnov and Anderson-Darling goodness-of-fit tests measure the accuracy of the hypothesis that the fracture

data come from a population with a distribution specified by the estimated Weibull parameters. Ninety-percent confidence intervals on the Weibull parameters and the unbiased value of the shape parameter for complete samples are provided when the maximum likelihood technique is used.

The probabilistic fast-fracture theories used in CARES, along with the input and output for CARES, are described. Example problems to demonstrate various features of the program are also included. This manual describes only the MSC/NASTRAN version of the CARES program.

Introduction

The beneficial properties of structural ceramics include their high-temperature strength, light weight, high hardness, and good corrosion and oxidation resistance. These properties provide the potential for greatly increased fuel efficiency and reduced emissions in aerospace and automotive engine applications. Consequently, research has focused on improving ceramic material properties and processing, as well as on establishing a sound design methodology. The emerging materials, particularly silicon nitride and silicon carbide, consist of abundant and nonstrategic constituents and have the potential for competing with traditional metals in many demanding applications. For advanced heat engines, ceramic components have already demonstrated functional abilities at temperatures approaching 1371 °C (2500 °F)—well beyond the operational limits of most metallic materials.

Unfortunately, ceramics also have several inherent undesirable properties which must be considered in the design procedure. The most deleterious of these properties is that ceramics are brittle materials. This lack of ductility and yielding capability leads to low strain tolerance, low fracture toughness, and a large variation in observed fracture strength. When a load is applied, the absence of significant plastic deformation or microcracking causes large stress concentrations to occur at microscopic flaws, which are unavoidably present as a result of materials processing operations or in-service environmental factors. The observed scatter in component strength is caused by the variable severity of these flaws and by the behavior of sudden catastrophic crack growth which occurs when the crack driving force or energy release rate reaches a critical value.

Because ceramics fail at the weakest flaw, examination of their fracture surfaces can reveal the nature of the failure. Fractography of broken samples has shown that these flaws can be characterized into two general categories: (1) defects internal or intrinsic to the material volume (volume flaws) and (2) defects extrinsic to the material volume (surface flaws). Intrinsic defects are a result of materials processing. Extrinsic flaws can result from grinding or other finishing operations, from chemical reaction with the environment, or from the internal defects intersecting the external surface. The different physical nature of these flaws results in dissimilar failure response to identical loading situations. Consequently, separate criteria must be employed to describe the effects of the applied loads on the component surface and volume.

Because of the statistical nature of these flaw populations, the size of stressed material surface area and volume (known as the size effect) affects the strength. For example, suppose a set of samples with a known geometry experiences a load such that 10 percent of the specimens break at a stress of 500 MPa (72 520 psi) or lower. In this case, there is a 10-percent chance that a flaw of this strength or lower is present in any given specimen. If the specimen geometry is scaled such that the surface area and volume are 10 times larger, then for the same loading, there is a $100.0 - (1.0 - 0.1)^{10}$ (100.0) = 65 percent chance that a flaw of strength 500 MPa (72 520 psi) or lower is present in any given specimen. Clearly, by increasing component size, the average strength is reduced because of the increased probability of having a weaker flaw. For metals generally, the variation of strength is small, and thus the scaling effect is negligible; however, for materials that display large variations of strength, this effect is not trivial. Hence, if a ceramic design is based on material parameters obtained from smaller size test pieces, then the effects of scaling must be taken into account, otherwise a nonconservative design will result.

Another consequence of the random distribution of flaws is that failure of a complex component may not be initiated at the point of highest nominal stress. A particularly severe flaw may be located at a region of relatively low stress, yet still be the cause of component failure. For this reason, the entire field solution of the stresses should be considered. Clearly, it is not adequate to predict reliability based only on the most highly stressed point.

Traditional analysis of the failure of materials uses a deterministic approach, where failure is assumed to occur when some allowable stress level or equivalent stress is exceeded. The most widely used of these theories are the maximum normal stress, maximum normal strain, maximum shear stress, and maximum distortional energy criteria of failure. These phenomenological failure theories have been reasonably successful when applied to ductile materials such as metals. However, these methods do not account for observed variations in ceramic component fracture stress. Therefore, to assure high reliability in brittle material design, large factors of safety are required. This approach does not

allow for optimization of design since the physical phenomena that determine fracture response are not accurately modeled.

Because of its lack of a proper physical basis, the traditional approach to design is not adequate to predict failure of brittle materials. Consequently, Griffith (refs. 1 and 2) proposed a fracture theory where failure was due to the presence of cracks of specified size and shape distributed randomly throughout the material. He assumed that no interaction takes place between adjacent cracks and that failure occurs at the flaw with the least favorable orientation relative to the macroscopic loading. The Griffith energy balance criterion for fracture states that crack growth will occur if the energy release rate reaches a critical value. Griffith's theory provides a sound physical basis to describe the rupture process in an isotropic brittle continuum. However, it omits the effect of component size on strength because the crack length is not treated as a probabilistic quantity.

Reliability analysis is essential for accurate failure prediction and efficient structural utilization of brittle materials subjected to arbitrary stress states. When coupled with the weakest-link model (ref. 3), this approach takes into account not only the size effect and loading system, but also the variability in strength due to defect distributions. A statistical theory of failure can be readily incorporated into the finite element method of structural analysis since each element can be made arbitrarily small such that the element stress gradient is negligible. Component integrity is computed by calculating element-by-element reliability and then determining the component survivability as the product of the individual element reliabilities.

The first probabilistic approach used to account for the scatter in fracture strength and the size effect of brittle materials was introduced by Weibull (refs. 3 to 5). This approach is based on the previously developed weakest-link theory (WLT) (refs. 6 to 8), which is primarily attributed to Pierce, who proposed it while modeling yarn failure. The weakest-link theory is analogous to pulling a chain, where catastrophic failure occurs when the weakest link in the chain is broken. Unlike Pierce, who assumed a Gaussian distribution of strength, Weibull assumed a unique probability density function known as the Weibull distribution. It has been shown (ref. 9) that the three-parameter Weibull distribution is a more accurate approximation of ceramic material behavior than the Gaussian or other distributions. The Weibull material parameters are usually determined from flexural or uniaxial tensile specimens.

To predict material response under multiaxial stress states by using statistical parameters obtained from flexural or uniaxial tests, Weibull proposed calculating the risk of rupture by averaging the tensile normal stress raised to an exponent in all directions. Although this approach is intuitively plausible, it is somewhat arbitrary. In addition, it lacks a closed-form solution, and therefore, requires computationally intensive numerical modeling. Subsequently, Barnett and Freudenthal (refs. 10 and 11) proposed an alternative approach usually

referred to as the principle of independent action (PIA) model for finding the failure probability in multidimensional stress fields. This principle states that the Weibull survival probability of a uniformly stressed material element experiencing multiaxial loading is equal to the product of the survival probabilities for each of the principal stresses applied individually. The PIA fracture theory is the weakest-link statistical equivalent of the maximum stress failure theory. The Weibull method of averaging the tensile normal stress over the unit sphere (about all possible directions) and the principle of independent action model have been the most popular methods for polyaxial stress state analysis, and they have been widely applied in brittle material design (refs. 12 to 16).

However, the Weibull and PIA hypotheses do not specify the nature of the defect causing failure, and consequently, there is no foundation for extrapolating to conditions different from the original test specimen configuration. Attempts to experimentally verify the polyaxial predictions of these theories have been inconclusive, and the results are still controversial. Consequently, the accuracy of these theories has been questioned, and other statistical models have been introduced (refs. 17 to 19). The ideas developed by Batdorf and Crose (ref. 17) are important because they provide a physical basis for incorporating the effect of multiaxial stresses into the weakest-link theory. They describe material volume and surface imperfections as randomly oriented, noninteracting discontinuities (cracks) with an assumed regular geometry. This enables the contributions of shear and normal force to the fracture process to be treated explicitly. Failure is assumed to occur when the effective stress on the weakest flaw reaches a critical level. The effective stress is a combination of normal and shear stresses acting on the flaw. It is a function of the assumed crack configuration, the existing stress state, and the fracture criterion employed. Accounting for the presence of shear on the crack plane reduces the normal stress needed for fracture, yielding a more accurate reliability analysis than that of the shear-insensitive crack model (Weibull's method). Unlike the deterministic Griffith failure criterion, the size of the crack in the probabilistic approach need not be considered.

The search for an accurate fracture criterion to predict fast-fracture response to monotonically increasing loads leads to the field of fracture mechanics. Many authors have discussed the stress distribution around cavities of various types under different loading conditions, and numerous criteria have been proposed to describe impending failure. Paul and Mirandy (ref. 20) extended Griffith's maximum tensile stress criterion for biaxial loadings to include three-dimensional effects due to Poisson's ratio and flaw geometry, which could not be accounted for in Griffith's previous two-dimensional analysis. Other investigators (refs. 21 to 24) have compared results from the most widely accepted mixed-mode fracture criteria with each other and with selected experimental data. No prevailing consensus has emerged regarding a best theory. Also, most of the criteria predict somewhat similar results, despite the divergence of initial assumptions. Therefore, the authors of

this report concluded that several alternatives would be made available for the sake of comparison but that the semi-empirical equation developed by Palaniswamy and Knauss (ref. 25) and Shetty (ref. 26) provides the most flexibility to fit the available experimental data. In addition, Shetty's criterion can account for the out-of-plane flaw growth that is observed under mixed-mode loadings. Finally, several different flaw geometries are provided, but the penny-shaped and semicircular crack configurations are recommended as the most accurate representations of volume and surface defects, respectively.

The primary objective of this report is to describe a public domain computer program that is coupled with the general purpose finite element code MSC/NASTRAN (MacNeal-Schwendler Corporation/NASA STRUCTURAL ANALYSIS) (ref. 27) for predicting the fast-fracture failure probability of ceramic components. The name of the code (refs. 28 to 30) was changed to CARES (Ceramics Analysis and Reliability Evaluation of Structures) from SCARE (Structural Ceramics Analysis and Reliability Evaluation). The acronym was changed so as not to convey the wrong message and also to indicate completion of the program's initial analysis capabilities. The intent of the original acronym was to motivate engineers to learn a new design technique. The program has also been adapted to accept ANSYS finite element results (ref. 31). Planned near-future enhancements include a time-dependent reliability analysis that accounts for subcritical crack growth under cyclic and/or sustained loads.

This report functions as both a user's and a programmer's manual. The user can focus primarily on the first five sections of this manual for background information and for detailed descriptions of the program capabilities, setup and execution on the VM/CMS and VMS operating systems, input, and output. In addition, five example problems are included in the section **Example Problems** to further illustrate program input, output, and interpretation of results. These examples also provide program validation and verification. It is strongly recommended that the user read the theoretical section (**Theory**) as well for a better understanding of the probabilistic fast-fracture theories employed. All of these sections and the subroutine descriptions are essential to a programmer who may wish to modify the source code. In addition a list of symbols and a glossary of terms have been included to aid the reader (appendixes A and B).

Program Capability and Description

CARES is an integrated computer program written in FORTRAN 77 which uses Weibull and Batdorf fracture statistics to predict the reliability of isotropic ceramic components. CARES has three primary functions: (1) statistical analysis of the data obtained from the fracture of simple, uniaxial tensile or flexural specimens, (2) estimation of the Weibull and Batdorf material parameters from this data, and (3) fast-fracture reliability evaluation of a ceramic component experi-

encing thermomechanical loading. The component reliability is predicted by using elastostatic finite element analysis output from the MSC/NASTRAN or ANSYS computer programs. Data analysis and reliability evaluation are performed as a function of temperature and surface area and/or volume. Material parameter calculations are independent of finite element output. Figure 1 illustrates the operational flow of the program. Component reliability for volume flaws is determined from element stress, temperature, and volume output from isoparametric three-dimensional or axisymmetric elements. Reliability for surface flaws is calculated from isoparametric shell element stress, temperature, and area data.

The weakest-link mechanism is expressed with the classical Weibull two-parameter formulation, which for volume flaw reliability is

$$P_{sV} = \exp \left[- \int_V \left(\frac{\sigma}{\sigma_{oV}} \right)^{m_V} dV \right] \quad (1)$$

and for surface flaw reliability is

$$P_{sS} = \exp \left[- \int_A \left(\frac{\sigma}{\sigma_{oS}} \right)^{m_S} dA \right] \quad (2)$$

where P_s is the survival probability and σ is the applied uniaxial tensile stress. Here V is the volume of stressed material, and A is the area. The subscripts V and S denote parameters that are a function of material volume and surface area, respectively. The scale parameter σ_o has dimensions of stress \times (volume) $^{1/m_V}$ or stress \times (area) $^{1/m_S}$. The scale parameter corresponds to the stress level at which 63.2 percent

of specimens with unit volume or area would fracture. The shape parameter (or Weibull modulus), denoted by m , is a dimensionless quantity and measures the degree of strength dispersion of the flaw distribution.

The finite element method of analysis is an ideal mechanism for calculating the survival probability of a structure since each element can be made arbitrarily small such that the stresses can be taken as constant throughout each element. Therefore, the area and volume integrations are performed only at the element level for which stresses, temperatures, volumes, and areas are readily available. The overall component reliability is, then, the product of all the calculated element survival probabilities.

In CARES, if a principal compressive stress in an element is at least three times greater than the maximum principal tensile stress in absolute value, or if the maximum principal stress is compressive, then the corresponding element reliability is set equal to unity. Typically, brittle materials are much stronger in compression than in tension. It is assumed that the lower tensile strength limit will predominate over the higher compressive limit for a typical component design. If the compressive stresses are significant, they should be checked against limiting values by other methods.

Figure 2 shows the fracture criteria and flaw geometries available to the user for both surface and volume flaw analysis. The simple PIA fracture theory does not require a specific crack geometry. Also note that when the PIA model is used, only tensile principal stresses can contribute to failure. The Weibull normal stress averaging method is also independent of crack geometry, since it only considers impending mode I (opening mode) crack growth, and neglects mode II (sliding mode) and mode III (tearing mode) effects. Batdorf's fracture theory can be used with several different mixed-mode fracture

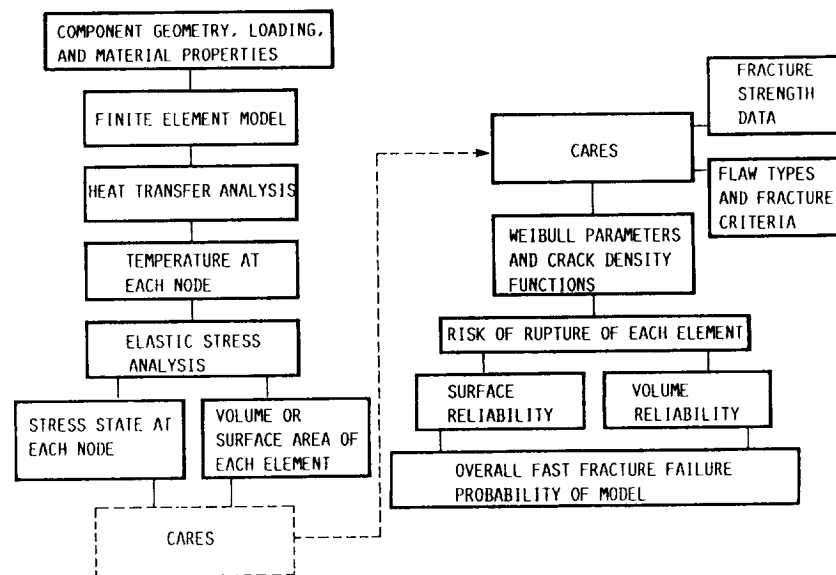

Figure 1.—Block diagram for the analysis and reliability evaluation of ceramic components.

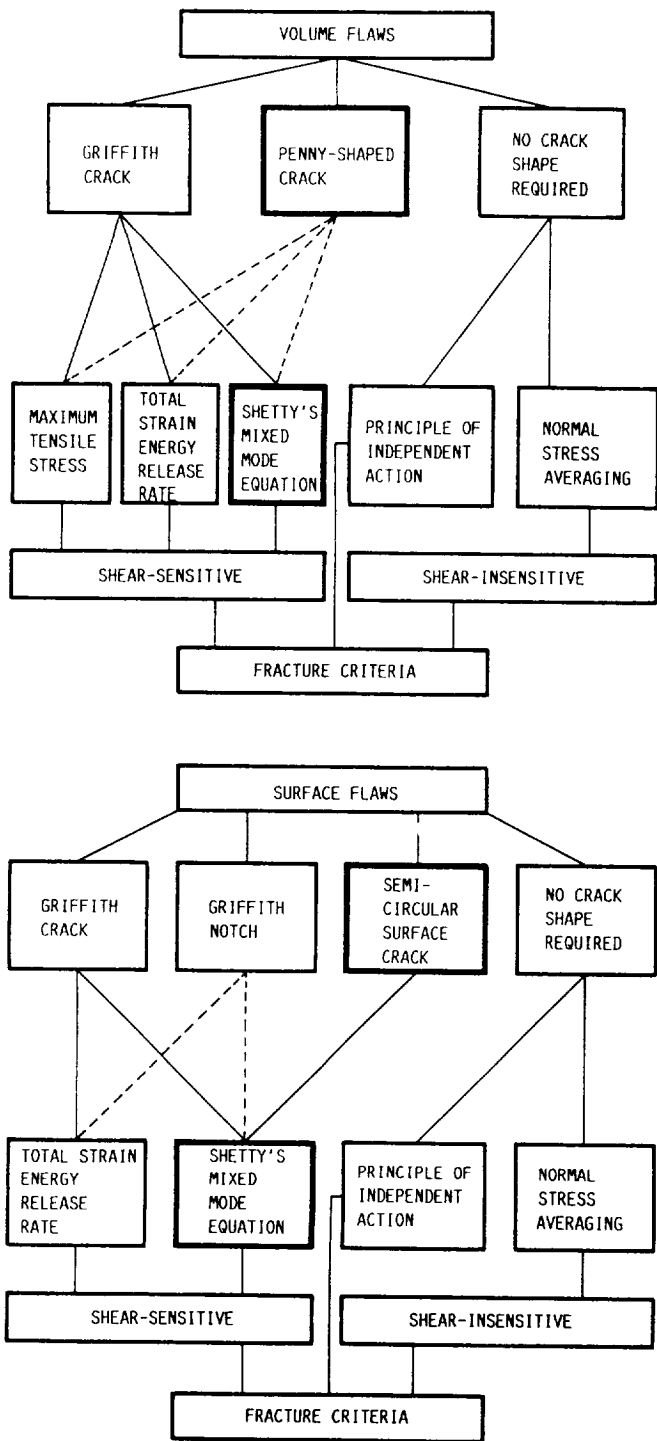

Figure 2.—Available failure criteria and crack shapes.

criteria and crack geometries. The combination of a particular flaw shape and fracture criterion results in an effective stress equation involving far-field principal stresses in terms of normal and shear stresses acting on the crack plane. The coplanar crack extension criterion for shear-sensitive materials available in CARES is the total strain energy release rate

theory. Out-of-plane crack extension criteria are approximated by a simple semi-empirical equation (ref. 25). This equation involves a parameter that can be varied to model the maximum tangential stress theory, the minimum strain energy density criterion, the maximum strain energy release rate theory, or experimental results. For comparison, Griffith's maximum tensile stress analysis for volume flaws is also included. The highlighted boxes in figure 2 show the recommended fracture criteria and flaw shapes.

Determination of the statistical material parameters is the first step in the reliability evaluation process. In general, the parameters are obtained from the fracture stresses of many specimens (30 or more are recommended) whose geometry and loading configurations are held constant. Solutions for the four-point modulus-of-rupture (MOR) bending bar (ref. 32) and the pure tensile specimen (ref. 33) maintained at a constant specified temperature have been incorporated into the CARES program. Since the material parameters are a function of temperature, up to 20 constant-temperature data sets can be input and the corresponding parameter estimates will be calculated. For other temperatures, Lagrangian polynomials are utilized to interpolate the parameter values. Each constant-temperature data set can consist of up to 200 specimens. In addition, each specimen can be identified by its mode of failure—either volume flaw, surface flaw, or some other mode—so that parameter estimates for competing failure modes can be obtained. The statistical accuracy of the parameter estimates compared with the true material parameters depends on the number of specimens tested, assuming that the true distribution is a Weibull distribution.

Figure 3 shows the flowchart for the calculation of the statistical strength parameters of the two-parameter Weibull distribution for volume-flaw- and surface-flaw-induced fracture, with complete (single mode) or censored (multiple mode) samples, and the calculation of other statistical quantities. Following the input of specimen geometry, fracture stresses, and respective flaw origins, CARES will first identify any potential bad data (outliers). The outlier test developed by Stefansky (ref. 34) and subsequently used by Neal, Vangel, and Todt (ref. 35) is incorporated into the program. Although the technique is based on the normal distribution and, therefore, its application to the Weibull distribution is not rigorous, it serves as a guideline to the user. Data detected as outliers are flagged with a warning message, and any further action is left to the discretion of the user.

Weibull parameter estimates are obtained for the specimen surface and/or volume as requested by the user, taking into account the fracture origin data also supplied by the user. Biased estimates of the Weibull shape parameter and characteristic strength are obtained from either least-squares analysis or the maximum likelihood method for complete samples and/or censored samples. CARES uses the Weibull log-likelihood equations given in Nelson (ref. 36) and the rank increment adjustment method described by Johnson (ref. 37), for complete and censored statistics.

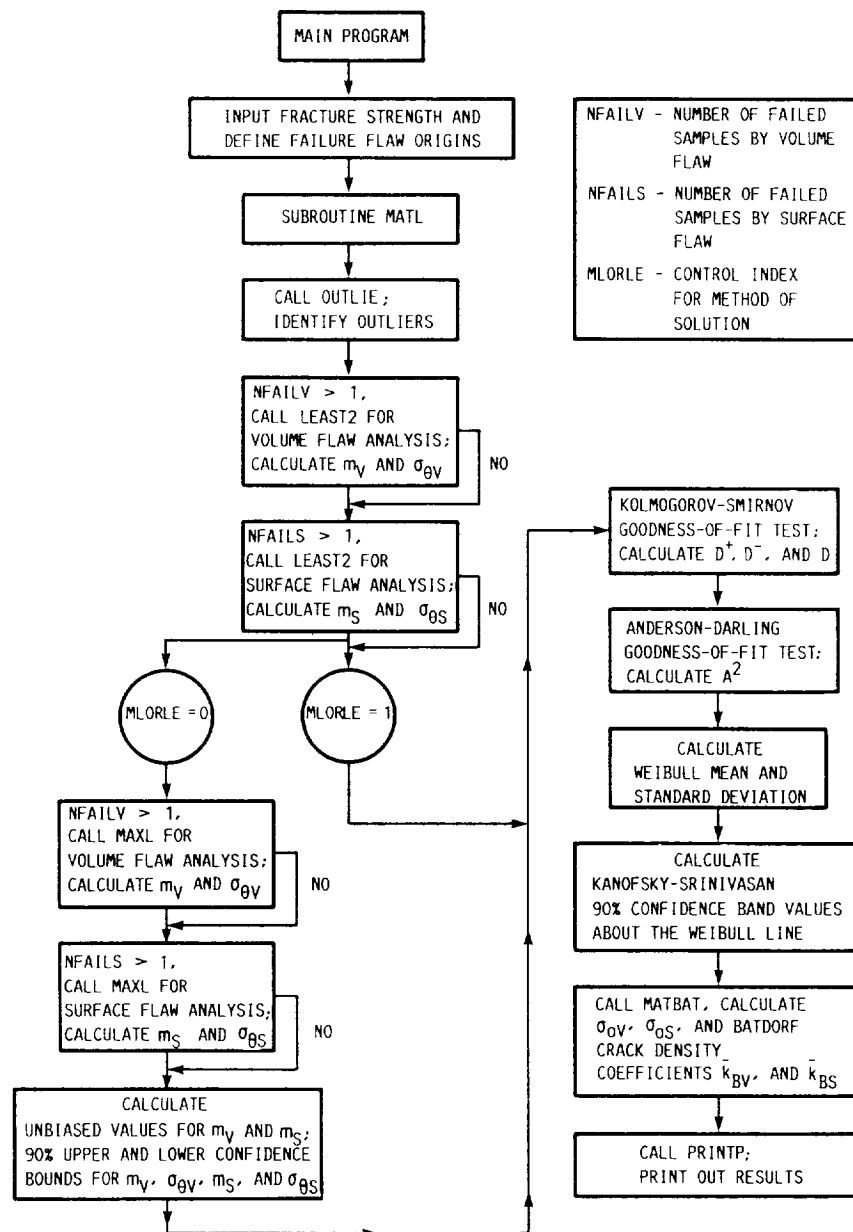

Figure 3.—Flowchart for calculation of material statistical strength parameters.

Because the estimates of parameters are obtained from a finite amount of data, they contain an inherent uncertainty that can be characterized by bounds in which the true parameters are likely to lie. Methods have been developed to evaluate confidence limits that quantify this range with a level of probability as a function of sample size. For the maximum likelihood method with a complete sample, unbiased factors for the shape parameter m , and 5- and 95-percent confidence limits for m and the characteristic strength σ_b , are provided (ref. 38). The characteristic strength, or characteristic modulus of rupture, is similar to the Weibull scale parameter except that it includes the effect of the total specimen volume or area. For a censored sample, an asymptotic approximation of the

90-percent confidence limits is calculated. No unbiasing of parameters or estimation of confidence limits is given when the least-squares option is requested.

The ability of the parameter estimates to reasonably fit the empirical data is measured with the Kolmogorov-Smirnov (K-S) and Anderson-Darling (A-D) goodness-of-fit tests. These tests are extensively discussed by D'Agostino and Stephens (ref. 39). The tests quantify discrepancies between the experimental data and the estimated Weibull distribution by a significance level associated with the hypothesis that the data were generated from the proposed distribution. The A-D test is more sensitive than the K-S test to discrepancies at low and high probabilities of failure. The Kanofsky-Srinivasan 90-percent confidence

band values (ref. 40) about the Weibull line are given as an additional test of the goodness-of-fit of the data to the Weibull distribution.

After the shape and characteristic strength parameters are estimated and analyzed, CARES calculates the other material parameters necessary for the reliability analysis. The biased estimate of the shape parameter m and the estimated characteristic strength σ_0 are used along with the specimen geometry to calculate the Weibull scale parameter σ_n . The Batdorf normalized crack density coefficient \bar{k}_B , which is explained in the section **Theory**, is computed from the selected fracture criterion, crack geometry, and the biased estimate of the shape parameter.

The reliability analysis portion of the CARES program uses finite element elastostatic output to calculate fast-fracture reliability for each element. Volume-flaw-based reliability is calculated from the previously determined volume statistical material strength parameters and the output of the stresses, volumes, and temperatures for each solid element. Volume flaw analysis requires output from MSC/NASTRAN element types HEXA, PENTA, or TRIAX6. The HEXA and PENTA labels designate six-sided and five-sided solid isoparametric elements, respectively. The TRIAX6 label represents an axisymmetric isoparametric element. Surface-flaw-based reliability is calculated from the surface statistical material strength parameters and individual shell element output of the two-dimensional surface stresses, areas, and temperatures. Surface flaw analysis requires output from MSC/NASTRAN library element types QUAD8 and TRIA6, which designate quadrilateral and triangular isoparametric shell elements, respectively. Modeling with axisymmetric elements is not permitted for surface flaw reliability analysis because of NASTRAN restrictions on mixing element types. Shell elements are used to identify external surfaces of solid elements that correspond to the component external surfaces which are important to the reliability analysis.

Provision is made in CARES to permit the use of the cyclic symmetry modeling option in MSC/NASTRAN. CARES also permits the analysis of many simultaneously occurring flaw populations in a given finite element model (up to 100 different statistical material characterizations). Elements not designated as brittle materials are ignored in the reliability computations. Element temperatures are obtained by averaging the nodal temperatures. Temperature-dependent statistical material properties are interpolated at each individual element temperature. Element and nodal identification numbers can be arbitrary. A maximum of 2000 solid and 2000 shell elements can be used in the current version of the program. For applications exceeding the 2000 element limit, the array sizes in the code should be increased. The risk-of-rupture intensity is also calculated for each element, and these values are sorted to determine the maximum values.

Two versions of the code, designated as CARES1 and CARES2, are available. The CARES1 version assumes that stress and temperature gradients within each element are

negligible, and therefore, only element centroidal principal stresses are used in the reliability calculations. The CARES2 version takes into account element stress gradients by dividing each HEXA element into 27 subelements and each QUAD8 element into 9 subelements. Subelement centroidal principal stresses are then computed and used in the subsequent reliability calculations. Compared with CARES1, CARES2 enables the finite element model to consist of fewer elements with higher aspect ratios for the same level of convergence to the true solution.

The basic architecture of the CARES program is illustrated in figure 4. The MSC/NASTRAN analysis is run independently of the reliability calculations. CARES requires the printout file from the NASTRAN analysis to obtain the element volumes and areas and requires a punch file containing the BULK DATA and element stresses. Note that the output data from other general purpose analysis programs can be coupled to CARES, if similar structural elements are available along with their respective volumes, areas, and temperatures. Under a NASA grant, Cleveland State University Advanced Manufacturing Center has prepared a version of CARES that reads ANSYS finite element program output (ref. 31). The flowchart of the CARES1 version is similar to that shown in figure 4, except that the subroutines for discretizing the elements into subelements have been eliminated. To avoid potential numerical overflow or underflow problems, all of the experimental fracture stresses, as well as the principal stresses at the center of each element and subelement, are normalized. The normalizing stress for experimental strength data is the maximum value of all such data for that material. The appropriate value of σ_0 is used to normalize all finite element stresses. Since the value of the Batdorf crack density coefficient k_B for typical ceramic materials is extremely small, it is always normalized by multiplying it by σ_0^m (ref. 41).

As shown in figure 4, the CARES program requires the specification of several logical units prior to execution. (Particular unit numbers can be easily changed within the program.) Because the input files may be quite large, the code is set to run in batch mode, meaning it is not user interactive. One logical unit (denoted as unit 7 in fig. 4) is devoted to the storage of NASTRAN BULK DATA and element stresses created by a punch command in the NASTRAN case control. CARES will read the appropriate BULK DATA from the punch file, and because the BULK DATA are in a left-justified format, CARES will change them to right-justified data on another logical unit (denoted as unit 4 in fig. 4). This extra data file is useful because it echoes the input that CARES has recognized. Another logical unit (denoted as unit 3 in fig. 4) is used to contain the NASTRAN output data from the printout file, which includes element volumes and areas that the user requested with an appropriate NASTRAN parameter call. One logical unit (denoted as unit 5 in fig. 4) is devoted to input specifically needed to run CARES, such as master control indices, control indices specifying various fracture models, and temperature-dependent material data. Finally, one logical

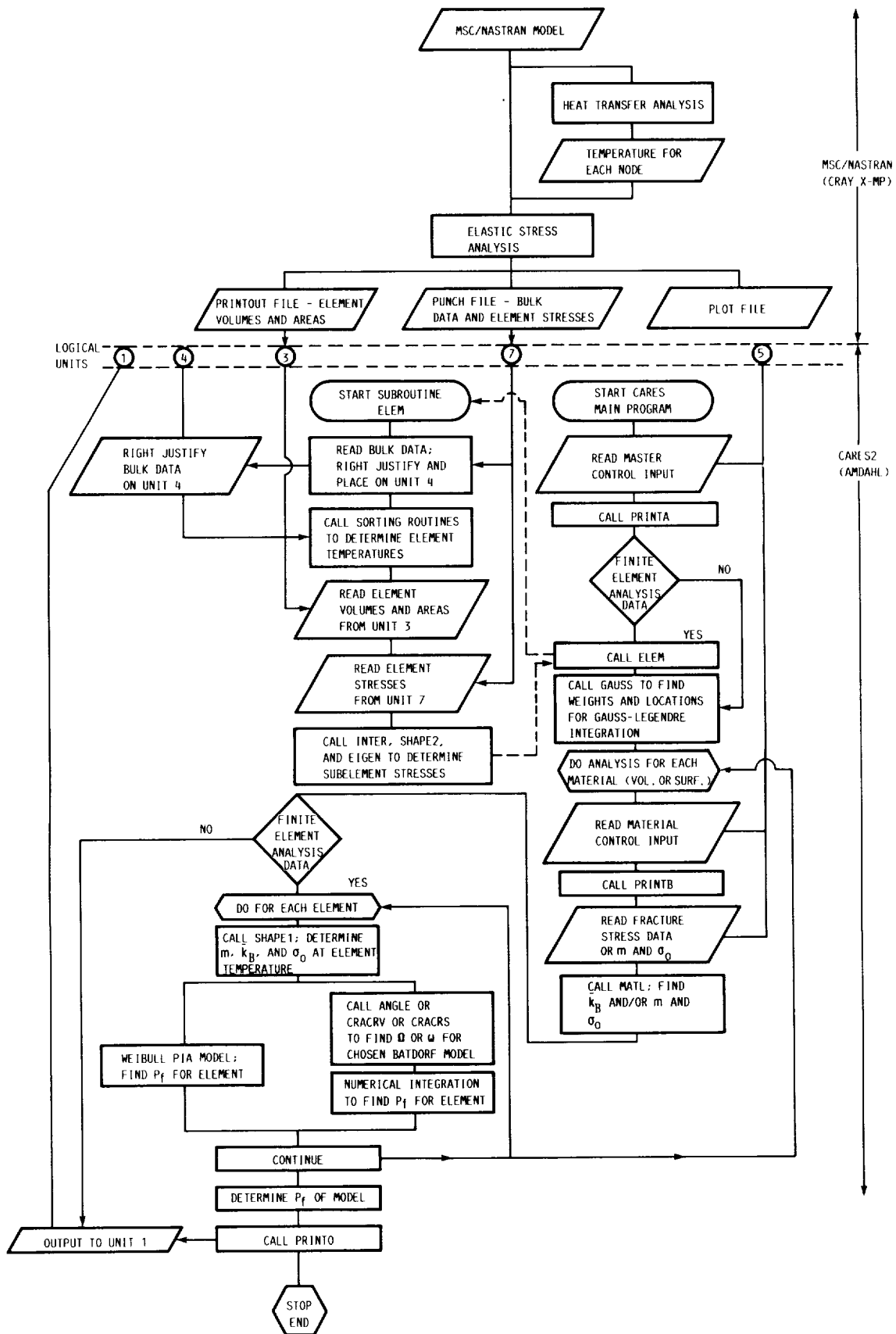

Figure 4.—Computational elements of the CARES2 reliability analysis program.

unit is used for CARES analysis output (denoted as unit 1 in fig. 4). Details of preparation and specification of data are included in the following section of this manual.

Input Information

Three categories of input are required to execute the CARES program: (1) Master Control Input, (2) Material Control Input (which includes temperature-dependent material data), and optionally, (3) MSC/NASTRAN OUTPUT DATA FILES from finite element analysis. The Master Control Input and the Material Control Input are contained in the file designated as logical unit 5 in figure 4. The Master Control Input is a set of control indices which directs the overall program execution. It specifies whether to perform material parameter analysis and/or reliability analysis of a finite element model. It also specifies the number of brittle material statistical characterizations. The Material Control Input consists of control indices and either the data required to estimate the statistical material parameters or direct input of the statistical parameter values themselves, for various temperatures. This input category includes the choices of fracture criteria and flaw shapes shown in figure 2. The third input category, MSC/NASTRAN OUTPUT DATA FILES, includes a NASTRAN punch file, which contains the BULK DATA with the element stresses, and the NASTRAN output file, which includes element volumes and areas. These files are designated as logical units 7 and 3, respectively, in figure 4. Each one of the three input categories will be explained in detail.

MSC/NASTRAN Finite Element Analysis

NASTRAN (NASA STRuctural ANalysis) is a large, comprehensive, general purpose finite element computer code for structural analysis which was developed under NASA sponsorship to fill the need for a universally available analysis program. It was initially released into the public domain in 1969 through COSMIC (COMputer Software Management and Information Center). In addition to the NASA-supported version, which is commonly called COSMIC/NASTRAN, there are several enhanced proprietary versions of this program. The most widely known of these proprietary versions is MSC/NASTRAN, which was developed and is maintained by the MacNeal-Schwendler Corporation. This version of NASTRAN includes a consistent set of isoparametric two- and three-dimensional elements, rigid elements, superelements for substructural analysis, improved cyclic symmetry, and numerical analysis and computer science enhancements. MSC/NASTRAN is widely used by many of the world's largest corporations, government laboratories, and most of the large commercial data centers.

MSC/NASTRAN creates and manipulates a data base to solve problems by matrix structural analysis. It includes rigid formats: that is, an ordered execution of a set of Direct Matrix

Abstraction Programming (DMAP) instructions. The CARES program utilizes results from only a very small fraction of available NASTRAN analysis capability. Since fast-fracture mechanical design of high-performance ceramic components requires temperature and stress solutions only, static analysis results from Solution Sequence 61 and Rigid Format 47 (in case of cyclic symmetry) are most often used.

The MSC/NASTRAN program is controlled by user-specified input data. The functions of the MSC/NASTRAN input can be logically described as

- (1) Defining the physical problem consisting of the finite element model, including constraints and loading conditions—the BULK DATA DECK
- (2) Providing user control over program input and output—the CASE CONTROL DECK
- (3) Providing user control over the MSC/NASTRAN executive functions—the EXECUTIVE CONTROL DECK

Preceding the entire NASTRAN data deck is the computer system Job Control Language (JCL) set of commands, which is dependent on the installation. At NASA Lewis Research Center, several JCL statements written for UNICOS (a UNIX-based CRAY operating system) are required to prepare a NASTRAN job for execution. They include information such as output or printout file name, estimated CPU time, required memory, user account information, optional NASTRAN plot file name, NASTRAN punch file name, and NASTRAN execution procedure. For self-contained NASTRAN analyses, assignment of logical units to handle NASTRAN input, punch, plot, and printout files is done automatically by a NASTRAN execution procedure (shell script) internal to the computer system.

Details of preparing an MSC/NASTRAN structural model with the selected elements can be found in reference 27 and in the appropriate MacNeal-Schwendler NASTRAN manuals. It is assumed that analysts using the CARES program are fully familiar with MSC/NASTRAN and its capabilities in solving heat transfer and stress analysis problems. For batch jobs with a large number of grid points and elements, MSC/NASTRAN can use a self-contained, three-dimensional solid modeling processor, called MSGMESH, to help model a given structure. Other mesh-generating programs, such as PATRAN, are also widely used for creating the MSC/NASTRAN BULK DATA. Using a mesh generator, however, may lead to nonconsecutive numbering of elements and grid points. Several sorting routines in CARES account for arbitrary numbering.

It should be noted that a new version of MSC/NASTRAN is made available to the user community every year. Currently Version 65C is being used on the NASA Lewis computer; consequently, it was the version used to solve the example problems summarized in the **Example Problems** section of this manual. A word of caution is in order at this point. Occasionally, coding errors arise in NASTRAN which, when reported to MacNeal-Schwendler Corporation, are usually corrected in later releases. MSC/NASTRAN Version 64 and earlier versions had coding errors in calculating TRIAX6

element volumes. These errors were supposedly corrected in Version 65, but we found this not to be true for the Version 65C running on our computer. In validating the CARES program, these element volumes were externally calculated, so unless the corrected Version 65 is available, models with TRIAX6 elements should not be used. Also, for a HEXA or PENTA element, significant error can be introduced in the calculation of the element volume when the element geometry has a large amount of curvature, especially when a coarse mesh is used. Finally, errors in stress computation occurred with Version 64 shell elements when nonuniform temperatures were imposed on a given element's nodes. This error should also have been corrected in Version 65, and it does appear that this problem has been fixed. (See the MSC/NASTRAN input/output files in the section **Example 4—Thermomechanically Loaded Annular Disk.**)

Executing MSC/NASTRAN

The MSC/NASTRAN program at NASA Lewis runs on a CRAY X-MP computer in a batch mode. Transfer of data to and from the CRAY is handled by an AMDAHL mainframe or scientific VAXcluster, which serve as front-end processors to the CRAY. Consequently, a set of JCL commands written in UNICOS for the CRAY computing environment is required to handle the involved data sets, logical units, and execution commands. Both versions of the CARES source program are stored on the AMDAHL mainframe. The AMDAHL computer at NASA Lewis uses IBM VM/CMS software for the operating system. Typically, to execute a MSC/NASTRAN problem, the user creates, with the help of a system editor, a file that consists of the necessary CRAY JCL commands, the EXECUTIVE and CASE CONTROL DECKs of NASTRAN, and the appropriate BULK DATA.

Preparation of MSC/NASTRAN Problem for Reliability Analysis With CARES

The following is an example of the MSC/NASTRAN EXECUTIVE CONTROL DECK for a typical problem involving static analysis, which is recommended to obtain satisfactory input for CARES postprocessing:

```

NASTRAN DAYLIMIT = -1
ID CERAMIC, FRACTURE
APP DISP
SOL 61
TIME 30
CEND

```

For problems that are modeled with cyclic symmetry, Solution Sequence 61 is replaced by Rigid Format 47.

It is assumed that the user is familiar with MSC/NASTRAN, so each statement will not be explained herein. However, the user should note that Solution Sequence 61 (SUPER-ELEMENT STATICS) and Rigid Format 47 (CYCLIC STATICS) are used for the analysis. These solution methods

are employed because element volumes and areas can be obtained through a PARAM card located in the BULK DATA. Element volumes and areas are not available for Solution Sequence 38 (STATICS) or for Rigid Format 24 (STATICS), even when the previously mentioned PARAM card is present.

For the CASE CONTROL DECK, a typical problem without the cyclic symmetry option would contain

```

TITLE = USER OPTION
SUBTITLE = USER OPTION
SEALL = ALL
SPC = 10
MPC = 11
LOAD = 12
DISP = ALL
STRESS (PRINT, PUNCH) = ALL
ECHO = PUNCH
OUTPUT (PLOT)
PLOTTER NAST
:
:
BEGIN BULK

```

A problem with the cyclic symmetry option would typically contain

```

TITLE = USER OPTION
SUBTITLE = USER OPTION
SET 2 = 0
HARMONICS = 2
SPC = 1
LOAD = 10
SET 5 = 1
OUTPUT = 5
DISP = ALL
SET 8 = 1 THRU 1000 EXCEPT 200 THRU 300
STRESS (PRINT, PUNCH) = 8
ECHO = PUNCH
OUTPUT (PLOT)
PLOTTER NAST
:
:
BEGIN BULK

```

There are three items that are important to note. The first is that multiple load subcases are not defined. The MSC/NASTRAN version of CARES is not programmed to handle stress output from multiple subcases; therefore, separate NASTRAN executions are required for each variation of the loading. The second item is that element stress output is routed to the punch file and the printout file when STRESS (PRINT, PUNCH) is specified. All HEXA, PENTA, TRIAX6, QUAD8, and TRIA6 element stresses must be placed in the punch file. For the cyclic symmetry example, a SET card is shown to define which element numbers to include in the punch file. If the finite element model uses some elements other than HEXA, PENTA, TRIAX6, QUAD8, or TRIA6, then those elements should not have their stresses placed in the punch

file. An alternative to using a set card would be for the user to delete the stress output from the punch file for element types other than those mentioned previously. The last item to note is that the command ECHO = PUNCH; this command causes the BULK DATA to be written into the punch file. CARES reads the necessary BULK DATA, such as material ID, element connectivity, and nodal temperatures, from the punch file.

Selected cards from the BULK DATA deck are

```
BEGIN BULK
PARAM, EST, 1
TEMPD . . .
TEMP . . .
:
:
GRID . . .
:
:
CHEXA . . .
:
:
CPENTA . . .
:
:
CQUAD8 . . .
:
:
CTRIA6 . . .
:
:
PSOLID . . .
:
:
PSHELL . . .
:
:
ENDDATA
```

The PARAM,EST card will output element volumes and areas to the NASTRAN printout file. This card only functions for some solution sequences or rigid formats. Note that this version of CARES assumes that the printer control characters are present in the first column of the NASTRAN printout file. Failure to account for these characters will cause an error in the reading of the element areas and volumes. The TEMPD card is required if some grid points do not have an explicit temperature assignment. All nodes must have an associated temperature, either through a TEMP, TEMP*, or TEMPD card. Since this version of CARES does not examine cards for their subcase identity, caution must be exercised not to allow multiple temperature cases. Nodal temperatures are used by CARES to obtain the average element temperatures, which are not routinely available in MSC/NASTRAN.

General guidelines for modeling will now be discussed. Ceramics are extremely sensitive to geometric discontinuities and resulting stress concentrations. Solid elements have the best capability for modeling regions of high stress gradients, such as fillets and corners, and for outputting detailed stress maps. A study on the accuracy of NASTRAN solid elements

was made in reference 42, where it was concluded that quadratic elements are probably the most accurate and efficient in analyzing three-dimensional structures, especially with potential extremes in element aspect ratios. The CARES program utilizes results from isoparametric two- and three-dimensional, as well as axisymmetric, finite elements. Only the HEXA, PENTA, TRIAX6, QUAD8, and TRIA6 (quadratic or linear versions) elements can be used. The presence of the midside nodes is optional in CARES, but must be accounted for in the Master Control Input. The HEXA, PENTA, and TRIAX6 elements are used for volume-based reliability analysis, and the QUAD8 and TRIA6 elements are used for surface-based reliability analysis. The TRIAX6 element is a special case because it is axisymmetric, and therefore, it cannot be used for surface reliability analysis since the QUAD8 and TRIA6 elements cannot be attached to the modeled component surface.

For typical designs, the three-dimensional HEXA and PENTA elements should be used to model the whole ceramic structure, including thin cross sections such as blades. Where large stresses and stress gradients are coincident in a model, it is essential that a refined element mesh be used. An accurate stress solution from finite element analysis does not guarantee that an accurate reliability solution will be obtained. This is because reliability is calculated based on volume (or area) multiplied by stress raised to the exponent of the Weibull modulus. CARES2 reduces this mesh sensitivity somewhat since HEXA and QUAD8 elements are subdivided into 27 and 9 subelements, respectively.

The use of the two-dimensional QUAD8 and TRIA6 shell elements for surface reliability analysis is primarily to identify the corresponding external surfaces of the component. Note that shell elements used for structural modeling cannot be processed correctly by CARES unless CARES is modified to read both upper and lower surface stress states. These elements can be excluded from the reliability analysis by using a different material property identification number. The shell elements are needed by CARES to identify the model surface and to obtain corresponding two-dimensional stress states, areas, and surface temperatures. The shell elements are attached to the appropriate faces of the solid elements, consistent with the component external surfaces. Shell elements and solid elements should use the same nodes. An external quadrilateral face of a solid element should have a QUAD8 element attached to its nodes. The triangular face of a PENTA element should share nodes with a TRIA6 element. The shell elements should not contribute significantly to the structural stiffness of the model. This is achieved by specifying shell elements with membrane properties only and with a small thickness. Therefore, a typical PSHELL card would be

```
PSHELL, 101, 300, .000001
```

The entry 101 in field 2 represents the PSHELL identification number as it appears in the element connectivity card (CQUAD8 or CTRIA6). The entry 300 in field 3 is the

material identification number for the membrane properties material card. The entry 0.000001 in field 4 is the thickness of the element; a small nonzero value is used so that the element stiffness contribution is negligible relative to the solid element. Material identification numbers for bending and transverse shear are left blank, so that those effects are excluded. The PSOLID property card is used for the solid elements and is defined in the usual manner.

After execution of the MSC/NASTRAN problem, the analyst should have a punch file consisting of BULK DATA and element stresses, and an output file consisting of general problem information and individual element volumes and areas. At this point, all of the information required from MSC/NASTRAN to determine the component reliability is present.

CARES Input File Preparation

To control the execution of the CARES program, the user must prepare an input file (designated as logical unit 5 in fig. 4) consisting of the Master Control Input and the Material Control Input. On the tape or disks provided with the program is a file called TEMPLET INP that can be used to construct an input file for a particular problem. It is assumed that the CARES user has access to a full-screen editor where block manipulations and character editing can be easily done.

Input to CARES is keyword driven. The keywords can be present in any order within each input section, but they must start in the first column of the file. The beginning of this file is reproduced in figure 5. Note that underneath each keyword a location is given that specifies where the data value or values are input. An explanation of each keyword is provided to the right, and a list of available choices is given, if applicable. If integer input is required, then the input field is between two asterisks (*), and entries must be right justified. Real number input is read in an F10.4 format, and asterisks are not present to define the field width. A maximum of 30 lines between keywords is allowed before an error message is generated, and therefore, the user can insert short notes as desired. The Master Control Input always comes at the beginning of a file.

CARES begins execution by searching for the keywords associated with the Master Control Input. The end of the Master Control Input occurs when the \$ENDX keyword is encountered. Following the Master Control Input, CARES searches for keywords specific to the Material Control Input. The \$ENDM and \$ENDT keywords signal the end of two different sections of the Material Control Input. Keywords not found between \$END intervals may assume default values. Because CARES has a multiple material capability, each section of input for a particular material is separated by a \$ENDT card. The TEMPLET INP file has only two materials characterized. Modifying the file for more materials involves block copying sections of the original file, appending them to the end of the file, and modifying the copied input values accordingly. The user is advised to keep an unaltered copy

of the TEMPLET INP file as a backup. Details on specific input preparation are described in the *Master Control Input* and *Material Control Input* sections of this manual. Each keyword is discussed briefly in these sections, and the format field for the input is denoted in parentheses next to the keyword.

Master Control Input.—The Master Control Input section from the TEMPLET INP file is reproduced in figure 5. If parameter keywords are omitted, they assume their default values as defined in figure 5.

IPRINT (4X,I1) The keyword IPRINT controls the printing of element stresses and experimental fracture stresses. It gives the user the option to control the length of the program output. If IPRINT = 0, the element stresses and/or specimen fracture data are not printed. If IPRINT = 1, all element stresses and/or fracture data are echoed in the CARES output.

LONL (4X,I1) The keyword LONL indicates whether the element midside nodes are to be considered when computing the average element temperature. A linear element would not account for the midside nodes when determining the average element temperature. The elements to be evaluated for reliability should consistently have all midside nodes present if LONL = 1. The presence of midside nodes is optional if LONL = 0 because they are ignored in the calculation of the average element temperature.

NE (4X,I1) NE allows for postprocessing of the finite element output. If NE is zero, then CARES only estimates material parameters. If NE is not zero, then the finite element analysis output is processed. If NE = 1, CARES reads the MSC/NASTRAN output. If NE = 2, CARES reads the ANSYS output. Note that the maximum number of solid or shell elements for which reliability analysis can be performed is 2000 each in this version of CARES.

NGP (4X,I2) NGP controls the number of Gaussian integration points that are used in the reliability calculations. An entry of 30 will give better accuracy but at the penalty of larger CPU requirements than an entry of 15. There are also other options for NGP in CARES, but users should not specify less than 15 Gaussian points.

NMATS,NMATV (4X,I2) The keyword NMATS represents the number of materials for which surface flaw analysis is performed. NMATV represents the number of materials for which volume flaw analysis is performed. NMATS is associated with QUAD8 and TRIA6 shell elements, and NMATV is associated with HEXA, PENTA, and TRIAX6 elements. A component consisting of one material may have one set of statistical material parameters to characterize the surface and another set for the volume, for which NMATS = 1

--- CARES TEMPLAT INPUT FILE ---

```
*****
*
*      RELIABILITY PREDICTION FOR BRITTLE MATERIAL STRUCTURES      *
*      --- FAST FRACTURE STATISTICS ---                            *
*
*****

      MASTER CONTROL INPUT

TITLE      : PROBLEM TITLE (ECHOED IN CARES OUTPUT)
-----
SAMPLE INPUT FOR CARES USERS MANUAL
-----

NE         : CONTROL INDEX FOR FINITE ELEMENT POSTPROCESSING
-----
          *0*      0 : EXPERIMENTAL DATA ANALYSIS ONLY
          1 : MSC/NASTRAN ANALYSIS
          2 : ANSYS ANALYSIS

NMATS      : NO. OF MATERIALS FOR SURFACE FLAW ANALYSIS
-----
          *01*     (NMATS+NMATV < 101)
          (DEFAULT: NMATS = 0)

NMATV      : NO. OF MATERIALS FOR VOLUME FLAW ANALYSIS
-----
          *01*     (NMATS+NMATV < 101)
          (DEFAULT: NMATV = 0)

IPRINT     : CONTROL INDEX FOR STRESS OUTPUT
-----
          *1*      0 : DO NOT PRINT ELEMENT STRESSES AND/OR FRACTURE DATA
          1 : PRINT ELEMENT STRESSES AND/OR FRACTURE DATA

LONL       : CONTROL INDEX FOR LINEAR OR QUADRATIC ELEMENTS
-----
          *0*      0 : LINEAR
          1 : QUADRATIC (MIDSIDE NODES REQUIRED)

NGP        : NO. OF GAUSSIAN QUADRATURE POINTS (15 OR 30)
-----
          *15*     (DEFAULT: NGP = 15)

NS         : NO. OF SEGMENTS IN CYCLIC SYMMETRY PROBLEM
-----
          *001*    (DEFAULT: NS = 1)

*****
$ENDX      : END OF MASTER CONTROL INPUT
*****
```

Figure 5.—CARES Master Control Input.

and $NMATV = 1$. Statistical material parameters are a function of processing, microstructure, and environment. The CARES program is capable of analyzing a single material with multiple statistical material characterizations or many materials with multiple statistical material characterizations. For example, if a single material component has two different surface finishes, then $NMATS = 2$ is used because two different sets of statistical material parameters are required. The only constraint is that the total of $NMATS + NMATV$ must be less than 101. Note that only one set of statistical material parameters can be assigned to any given element.

NS (3X,I3) Because a finite element model may consist of only a fraction of the total ceramic component, the NS keyword allows for multiplication of the model geometry by the appropriate number of times when the reliability of the entire component is desired. For cyclic symmetry, NS corresponds to the number of segments required to reproduce the whole component.

TITLE (72A1) The input associated with the TITLE keyword is reproduced in the program output for problem identification. The NASTRAN TITLE and SUBTITLE cards from the CASE CONTROL DECK are also printed in the output.

\$ENDX The keyword \$ENDX signifies the end of the MASTER CONTROL INPUT.

Material Control Input.—A sample of the Material Control Input section from the TEMPLET INP file is reproduced in figures 6 and 7. These figures are an example of the input required for CARES to estimate the volume flaw statistical material parameters from experimental fracture data. Figures 8 and 9 show examples of the input needed to estimate the surface flaw statistical material parameters from experimental fracture data. Note that the Material Control Input actually consists of two different data partitions. Figures 6 and 7, for example, make up a single section of the Material Control Input. In figure 6, the control indices, material constants, and geometric variables necessary to calculate volume flaw statistical parameters are shown. In figure 7, the temperature-dependent fracture data are given. The temperature-dependent fracture data (MOR), or temperature-dependent values of the Weibull shape and scale parameters (PARAM), are always placed immediately following the control indices for that material. The total number of Material Control Input sections is equal to the sum of $NMATS + NMATV$ from the Master Control Input. Note that keywords that are not found assume default values.

It should also be noted that the material Poisson's ratio is a required input. Other temperature-dependent physical and mechanical properties—such as Young's modulus, thermal conductivity, thermal coefficient of expansion, and specific

heat—are required for MSC/NASTRAN analysis but are not used for reliability evaluation. It is assumed that Poisson's ratio is constant and temperature independent.

Material- and specimen-dependent data: The following keywords are the control indices, material indices, and geometric variables necessary for calculation of volume and surface flaw statistical parameters as shown in figures 6 and 8.

C (F10.4) If $ID2S = 5$ or $ID2V = 5$ (that is, if the Shetty's mixed-mode fracture criterion is selected), then the value of the empirical constant \bar{C} , denoted by the keyword C, must be specified. If this criterion is not selected, this input is ignored and can be deleted.

DL1, DL2, DH, DW (F10.4) If $ID1 = 2$ or 5 (that is, if statistical material parameters are to be determined from four-point MOR fracture specimens), then the specimen dimensions must be input. All dimensions must be input in units consistent with the finite element analysis. DL1 represents the length between the two outer symmetrical loads. DL2 is the length between the two inner central loads. DH is the total height of the test specimen cross section, and DW is the total width of the test specimen cross section.

ID1 (4X,I1) ID1 is a control index for specifying the form of the data to be input for obtaining the statistical material parameters. Either the Weibull shape and scale parameters are directly specified, or experimental fracture data are input. The fracture data can be either from four-point modulus-of-rupture bend bars or from tensile test specimens. If the fracture data are assumed to be all from one failure mode (all volume flaws or all surface flaws), then $ID1 = 1$ or 2 can be chosen. If $ID1 = 1$ or 2, then fracture origins are not input with the specimen fracture stresses, and CARES assumes that the fracture origins are consistent with the ID4 input index. If $ID1 = 4$ or 5, then fracture origins must be supplied with the fracture data.

ID2S, ID2V (4X,I1) The control indices ID2S and ID2V are for selection of a fracture criterion. ID2S is for a surface flaw fracture criterion (see fig. 8). ID2V is for a volume flaw fracture criterion (see fig. 6). If $ID4 = 1$, then ID2V should be specified. If $ID4 = 2$, then ID2S should be specified. If both ID2S and ID2V are specified in the same input section, the entry not consistent with the ID4 index is ignored. Shetty's mixed-mode fracture criterion is recommended for both surface and volume flaw analysis.

ID3S, ID3V (4X,I1) The ID3S and ID3V control indices are for selection of a crack geometry. ID3S is for surface flaw geometry (see fig. 8). ID3V is for volume flaw geometry (see fig. 6). If $ID4 = 1$, then ID3V should be specified. If $ID4 = 2$, then ID3S should be specified. If both ID3S and ID3V are specified in the same input section, the entry not consistent with the ID4 index is ignored. The penny-shaped

MATERIAL CONTROL INPUT

TITLE : MATERIAL TITLE (ECHOED IN CARES OUTPUT)

SAMPLE INPUT FOR CARES USERS MANUAL

MATID : MATERIAL IDENTIFICATION NO. FROM THE FINITE ELEMENT

MATERIAL PROPERTY CARD (IF POSTPROCESSING IS NOT
0000300 BEING PERFORMED THIS ENTRY SHOULD BE SOME UNIQUE NO.)

(NO DEFAULT)

ID1 : CONTROL INDEX FOR EXPERIMENTAL DATA

(NO DEFAULT)
5 1 : UNIFORM UNIAXIAL TENSILE SPECIMEN TEST DATA

2 : FOUR-POINT BEND TEST DATA
3 : DIRECT INPUT OF THE WEIBULL PARAMETERS, M AND SP
(SHAPE PARAMETER AND SCALE PARAMETER)
4 : CENSORED DATA FOR SUSPENDED ITEM ANALYSIS OF
UNIFORM UNIAXIAL TENSILE SPECIMEN TEST DATA
5 : CENSORED DATA FOR SUSPENDED ITEM ANALYSIS OF
FOUR-POINT BEND TEST DATA

ID4 : CONTROL INDEX FOR VOLUME OR SURFACE FLAW ANALYSIS

(NO DEFAULT)
1 1 : VOLUME

2 : SURFACE

ID2V : CONTROL INDEX FOR VOLUME FRACTURE CRITERION

(NO DEFAULT)
5 1 : NORMAL STRESS FRACTURE CRITERION

(SHEAR-INSENSITIVE CRACK)
2 : MAXIMUM TENSILE STRESS CRITERION
3 : COPLANAR STRAIN ENERGY RELEASE RATE CRITERION
(G SUB T)
4 : WEIBULL PIA MODEL
5 : SHETTY'S SEMI-EMPIRICAL CRITERION

ID3V : CONTROL INDEX FOR SHAPE OF VOLUME CRACKS

(NO DEFAULT)
2 1 : GRIFFITH CRACK

2 : PENNY-SHAPED CRACK

IKBAT : CONTROL INDEX FOR METHOD OF CALCULATING BATDORF CRACK

DENSITY COEFFICIENT (K SUB B) FROM TEST DATA
0 (DEFAULT: IKBAT = 0)

0 : SHEAR-INSENSITIVE METHOD (MODE I FRACTURE ASSUMED)
1 : SHEAR-SENSITIVE METHOD (FRACTURE ASSUMED TO OCCUR
ACCORDING TO THE FRACTURE CRITERION AND CRACK SHAPE
SELECTED BY THE ID2 AND ID3 INDICES)

Figure 6.—CARES Material Control Input for volume flaw analysis.

```

PR          : POISSON'S RATIO
-----
00000.2500
-----

C           : CONSTANT FOR SHETTY'S SEMI-EMPIRICAL MIXED-MODE FRACTURE
-----
00000.8000   CRITERION  $(K_I/K_{Ic}) + (K_{II}/(C * K_{Ic}))^{*2} = 1$ 
-----
              OBSERVED VALUES RANGE FROM 0.8 TO 2. (REF. D.K. SHETTY)
              NOTE: AS C APPROACHES INFINITY, PREDICTED FAILURE
              PROBABILITIES APPROACH NORMAL STRESS CRITERION VALUES
              (DEFAULT C = 1.0)

MLORLE     : CONTROL INDEX FOR METHOD OF CALCULATING WEIBULL
-----
              PARAMETERS FROM THE EXPERIMENTAL FRACTURE DATA
              (DEFAULT: MLORLE = 0)
              *1*
              0 : MAXIMUM LIKELIHOOD
              1 : LEAST-SQUARES LINEAR REGRESSION

DH         : HEIGHT OF THE FOUR-POINT BEND BAR
-----
00000.0710
-----

DL1        : OUTER LOAD SPAN OF THE FOUR-POINT BEND BAR
-----
00001.0000
-----

DL2        : INNER LOAD SPAN OF THE FOUR-POINT BEND BAR
-----
00000.5000
-----

DW         : WIDTH OF THE FOUR-POINT BEND BAR
-----
00000.1477
-----

*****
$ENDM      : END OF TEMPERATURE INDEPENDENT MATERIAL CONTROL INPUT
*****

```

Figure 6.—Concluded.

TEMPERATURE DEPENDENT MATERIAL CONTROL INPUT DATA
FOR THE ABOVE MATERIAL

!!

PLEASE NOTE THE FOLLOWING:

1. TEMPERATURE DEPENDENT DATA SETS MUST BE ARRANGED IN ASCENDING ORDER ACCORDING TO TEMPERATURE.
2. FRACTURE STRESSES FOR A GIVEN TEMPERATURE CAN BE INPUT IN ARBITRARY ORDER.
3. MAXIMUM NUMBER OF TEMPERATURE SETS IS 20.
4. MAXIMUM NUMBER OF FRACTURE SPECIMENS PER TEMPERATURE IS 200.
5. REGARDLESS OF THE FRACTURE ORIGIN LOCATION, THE FRACTURE STRESS INPUT VALUE IS THE EXTREME FIBER STRESS WITHIN THE INNER LOAD SPAN OF THE MOR BAR.

!!

TDEG : TEMPERATURE OF THIS SET

00070.0000

NUT : NUMBER OF FRACTURE SPECIMENS AT THIS TEMPERATURE

015

MOR : S-URFACE, V-OLUME, OR U-NKNOWN FLAW AND RESPECTIVE STRESS

VVV	0.457500E+05	0.461000E+05	0.481000E+05
VVV	0.481250E+05	0.491250E+05	0.491880E+05
VVV	0.495000E+05	0.496250E+05	0.496500E+05
VSV	0.497500E+05	0.498500E+05	0.498900E+05
SSU	0.506250E+05	0.516250E+05	0.522500E+05

-----*
END OF DATA FOR THE ABOVE TEMPERATURE
-----*

Figure 7.—Temperature-dependent fracture data for volume flaw analysis (censored data option).

```

TDEG      : TEMPERATURE OF THIS SET
-----
00500.0000
-----

NUT       : NUMBER OF FRACTURE SPECIMENS AT THIS TEMPERATURE
-----
      *015*
-----

MOR       : S-URFACE, V-OLUME, OR U-NKNOWN FLAW AND RESPECTIVE STRESS
-----*-----*-----*-----*
VVV      0.407500E+05      0.411000E+05      0.431000E+05
VVV      0.431250E+05      0.441250E+05      0.441880E+05
VVV      0.445000E+05      0.446250E+05      0.446500E+05
VVV      0.447500E+05      0.448500E+05      0.448900E+05
VVV      0.456250E+05      0.466250E+05      0.472500E+05
-----*-----*-----*-----*
                        END OF DATA FOR THE ABOVE TEMPERATURE

TDEG      : TEMPERATURE OF THIS SET
-----
01000.0000
-----

NUT       : NUMBER OF FRACTURE SPECIMENS AT THIS TEMPERATURE
-----
      *015*
-----

MOR       : S-URFACE, V-OLUME, OR U-NKNOWN FLAW AND RESPECTIVE STRESS
-----*-----*-----*-----*
UVV      0.357500E+05      0.361000E+05      0.381000E+05
VVV      0.381250E+05      0.391250E+05      0.391880E+05
VVV      0.395000E+05      0.396250E+05      0.396500E+05
VVS      0.397500E+05      0.398500E+05      0.398900E+05
VSS      0.406250E+05      0.416250E+05      0.422500E+05
-----*-----*-----*-----*
                        END OF DATA FOR THE ABOVE TEMPERATURE

*****
$ENDT      : END OF DATA FOR THE ABOVE MATERIAL
*****

```

Figure 7.—Concluded.

MATERIAL CONTROL INPUT

TITLE : MATERIAL TITLE (ECHOED IN CARES OUTPUT)

SAMPLE INPUT FOR CARES USERS MANUAL

MATID : MATERIAL IDENTIFICATION NO. FROM THE FINITE ELEMENT

MATERIAL PROPERTY CARD (IF POSTPROCESSING IS NOT
0000300 BEING PERFORMED THIS ENTRY SHOULD BE SOME UNIQUE NO.)

(NO DEFAULT)

ID1 : CONTROL INDEX FOR EXPERIMENTAL DATA

(NO DEFAULT)
2 1 : UNIFORM UNIAXIAL TENSILE SPECIMEN TEST DATA

2 : FOUR-POINT BEND TEST DATA
3 : DIRECT INPUT OF THE WEIBULL PARAMETERS, M AND SP
(SHAPE PARAMETER AND SCALE PARAMETER)
4 : CENSORED DATA FOR SUSPENDED ITEM ANALYSIS OF
UNIFORM UNIAXIAL TENSILE SPECIMEN TEST DATA
5 : CENSORED DATA FOR SUSPENDED ITEM ANALYSIS OF
FOUR-POINT BEND TEST DATA

ID4 : CONTROL INDEX FOR VOLUME OR SURFACE FLAW ANALYSIS

(NO DEFAULT)
2 1 : VOLUME

2 : SURFACE

ID2S : CONTROL INDEX FOR SURFACE FRACTURE CRITERION

(NO DEFAULT)
5 1 : NORMAL STRESS FRACTURE CRITERION

(SHEAR-INSENSITIVE CRACK)
3 : COPLANAR STRAIN ENERGY RELEASE RATE CRITERION
(G SUB T)
4 : WEIBULL PIA MODEL
5 : SHETTY'S SEMI-EMPIRICAL CRITERION

ID3S : CONTROL INDEX FOR SHAPE OF SURFACE CRACKS

(NO DEFAULT)
4 1 : GRIFFITH CRACK

(ASSOCIATED WITH STRAIN ENERGY RELEASE RATE CRIT.)
(ASSOCIATED WITH SHETTY'S SEMI-EMPIRICAL CRITERION)
3 : GRIFFITH NOTCH
(ASSOCIATED WITH STRAIN ENERGY RELEASE RATE CRIT.)
(ASSOCIATED WITH SHETTY'S SEMI-EMPIRICAL CRITERION)
4 : SEMICIRCULAR CRACK
(ASSOCIATED WITH SHETTY'S SEMI-EMPIRICAL CRITERION)

IKBAT : CONTROL INDEX FOR METHOD OF CALCULATING BATDORF CRACK

DENSITY COEFFICIENT (K SUB B) FROM TEST DATA
0 (DEFAULT: IKBAT = 0)

0 : SHEAR-INSENSITIVE METHOD (MODE I FRACTURE ASSUMED)
1 : SHEAR-SENSITIVE METHOD (FRACTURE ASSUMED TO OCCUR
ACCORDING TO THE FRACTURE CRITERION AND CRACK SHAPE
SELECTED BY THE ID2 AND ID3 INDICES)

Figure 8.—CARES Material Control Input for surface flaw analysis.

```

PR          : POISSON'S RATIO
-----
00000.2500
-----

C           : CONSTANT FOR SHETTY'S SEMI-EMPIRICAL MIXED-MODE FRACTURE
-----
CRITERION  $(K_I/K_{IC}) + (K_{II}/(C*K_{IC}))^2 = 1$ 
00000.8000  OBSERVED VALUES RANGE FROM 0.8 TO 2. (REF. D.K. SHETTY)
-----
NOTE: AS C APPROACHES INFINITY, PREDICTED FAILURE
PROBABILITIES APPROACH NORMAL STRESS CRITERION VALUES
(DEFAULT: C = 1.0)

MLORLE     : CONTROL INDEX FOR METHOD OF CALCULATING WEIBULL
-----
PARAMETERS FROM THE EXPERIMENTAL FRACTURE DATA
  *1*      (DEFAULT: MLORLE = 0)
-----
0 : MAXIMUM LIKELIHOOD
1 : LEAST-SQUARES LINEAR REGRESSION

DH         : HEIGHT OF THE FOUR-POINT BEND BAR
-----
(NO DEFAULT)
00000.0710
-----

DL1        : OUTER LOAD SPAN OF THE FOUR-POINT BEND BAR
-----
(NO DEFAULT)
00001.0000
-----

DL2        : INNER LOAD SPAN OF THE FOUR-POINT BEND BAR
-----
(NO DEFAULT)
00000.5000
-----

DW         : WIDTH OF THE FOUR-POINT BEND BAR
-----
(NO DEFAULT)
00000.1477
-----

*****
$ENDM      : END OF TEMPERATURE INDEPENDENT MATERIAL CONTROL INPUT
*****

```

Figure 8.—Concluded.

TEMPERATURE DEPENDENT MATERIAL CONTROL INPUT DATA
FOR THE ABOVE MATERIAL

!!
PLEASE NOTE THE FOLLOWING:
1. TEMPERATURE DEPENDENT DATA SETS MUST BE ARRANGED IN ASCENDING ORDER
ACCORDING TO TEMPERATURE.
2. FRACTURE STRESSES FOR A GIVEN TEMPERATURE CAN BE INPUT IN
ARBITRARY ORDER.
3. MAXIMUM NUMBER OF TEMPERATURE SETS IS 20.
4. MAXIMUM NUMBER OF FRACTURE SPECIMENS PER TEMPERATURE IS 200.
5. REGARDLESS OF THE FRACTURE ORIGIN LOCATION, THE FRACTURE STRESS
INPUT VALUE IS THE EXTREME FIBER STRESS WITHIN THE INNER LOAD SPAN
OF THE MOR BAR.
!!

TDEG : TEMPERATURE OF THIS SET

00070.0000

NUT : NUMBER OF FRACTURE SPECIMENS AT THIS TEMPERATURE

015

MOR : FRACTURE STRESSES

0.457500E+05	0.461000E+05	0.481000E+05
0.481250E+05	0.491250E+05	0.491880E+05
0.495000E+05	0.496250E+05	0.496500E+05
0.497500E+05	0.498500E+05	0.498900E+05
0.506250E+05	0.516250E+05	0.522500E+05

-----*
END OF DATA FOR THE ABOVE TEMPERATURE
-----*

Figure 9.—Temperature-dependent fracture data for surface flaw analysis (complete sample option).

TDEG : TEMPERATURE OF THIS SET

00500.0000

NUT : NUMBER OF FRACTURE SPECIMENS AT THIS TEMPERATURE

015

MOR : FRACTURE STRESSES

0.407500E+05	0.411000E+05	0.431000E+05
0.431250E+05	0.441250E+05	0.441880E+05
0.445000E+05	0.446250E+05	0.446500E+05
0.447500E+05	0.448500E+05	0.448900E+05
0.456250E+05	0.466250E+05	0.472500E+05

-----*

END OF DATA FOR THE ABOVE TEMPERATURE

TDEG : TEMPERATURE OF THIS SET

01000.0000

NUT : NUMBER OF FRACTURE SPECIMENS AT THIS TEMPERATURE

015

MOR : FRACTURE STRESSES

0.357500E+05	0.361000E+05	0.381000E+05
0.381250E+05	0.391250E+05	0.391880E+05
0.395000E+05	0.396250E+05	0.396500E+05
0.397500E+05	0.398500E+05	0.398900E+05
0.406250E+05	0.416250E+05	0.422500E+05

-----*

END OF DATA FOR THE ABOVE TEMPERATURE

\$ENDT : END OF DATA FOR THE ABOVE MATERIAL

Figure 9.—Concluded.

crack is recommended for volume flow analysis and the semicircular crack is recommended for surface flow analysis.

ID4 (4X,11) ID4 controls the calculation of volume- or surface-based statistical material parameters for the NASTRAN material card ID specified in MATID. From the fracture data supplied, the Weibull shape and scale parameters along with the normalized Batdorf crack density coefficient are estimated and are subsequently made available for postprocessing with finite element data. If the Weibull shape and scale parameters are directly input, then the normalized Batdorf crack density coefficient is calculated.

IKBAT (4X, 11) IKBAT selects the method of calculating the normalized Batdorf crack density coefficient. If IKBAT = 0, then the crack density coefficient is set to the value that is the solution for the normal stress fracture criterion, regardless of the fracture criterion and crack geometry selected by the user for subsequent component analysis. If IKBAT = 1, then the crack density coefficient is calculated based on the fracture criterion and crack geometry selected by ID2S and ID3S or by ID2V and ID3V for surface or volume flow analysis, respectively. IKBAT = 0 gives more conservative reliability predictions and usually agrees more closely with test data than IKBAT = 1 does; it is therefore recommended as the best choice unless specific data exist that indicate otherwise.

MATID (1X,17) MATID is the material identification number that is associated with statistical material parameter data. The value input should correspond to the material identification number listed in the NASTRAN BULK DATA (for example, the MAT1 card). If volume flow analysis is specified, the value of MATID should be referenced to CHEXA, CPENTA, and CTRIAX6 BULK DATA cards via PSOLID cards. If surface flow analysis is chosen, the value of MATID should be referenced to CQUAD8 and CTRIA6 cards via PSHELL cards. If postprocessing with MSC/NASTRAN is not being performed, MATID should be a unique integer value.

MLORLE (4X,11) MLORLE is the control index for the method of estimation of the Weibull shape parameter m and characteristic strength σ_θ from experimental fracture data. MLORLE is ignored if the Weibull shape and scale parameters are directly input.

PR (F10.4) PR is Poisson's ratio. It is assumed to be temperature independent.

TITLE (72A1) The input associated with the TITLE keyword is reproduced in the program output for material identification.

VAGAGE (F10.4) VAGAGE is the gage volume or area of a tensile test specimen. If ID4 = 2 and ID1 = 1 or 4 (that is, if surface flow analysis is specified and the statistical material parameters are to be determined from simple tension tests), then the gage surface area of the specimen must be specified. If ID4 = 1 and ID1 = 1 or 4 (that is, if volume flow analysis is specified and the statistical material parameters are to be determined from simple tension tests), then the gage volume of the specimen must be specified.

\$ENDM The keyword \$ENDM signifies the end of a section of the Material Control Input. The temperature-dependent specimen fracture data or the Weibull shape and scale parameters are assumed to immediately follow.

Temperature-dependent fracture or statistical material parameters data: Immediately following the \$ENDM keyword, which signals the end of the material- and specimen-dependent data, the temperature-dependent experimental fracture data or Weibull shape and scale parameters are input. Data for up to 20 different temperatures can be specified. Data must be arranged so that they correspond to ascending order of temperatures. These data enable interpolation of the statistical material parameters to other temperatures. Figures 7 and 9 show examples of the input for experimental fracture stress data. Figure 10 shows an example of the input for the Weibull shape and scale parameters.

MOR (3A1,3E18.10) or (3E18.10) MOR indicates that experimental fracture stresses will be input. Fracture stresses can be input in any order, with a maximum of 200 specimen failure stresses input for each temperature. There are two styles of input. If ID1 = 1 or 2 (that is, if the fracture data are assumed to be a complete sample), then fracture stresses only are input. The input format is 3E18.10 as shown in figure 9. Referring to figure 7, if ID1 = 4 or 5 (that is, if the fracture origins and the fracture stresses are to be input), then the input format is 3A1,3E18.10. The 3A1 represents three fields of single alphanumeric characters. This field is for fracture origin input. An "S" indicates a surface flow origin. A "V" represents a volume flow origin. A "U" indicates an unknown flaw origin. Each fracture stress has a corresponding fracture origin. In figure 7, each line of fracture data consists of three fracture origins followed by their respective failure stresses. Fracture data values should be unique, and multiple identical values should not be input (change one value slightly).

NUT (3X,13) NUT is the sample size of the experimental fracture data for the temperature indicated by TDEG. NUT is specified if ID1 does not equal 3 (statistical material parameters are not being directly input). Different numbers of specimens are permitted at different temperatures.

TEMPERATURE DEPENDENT MATERIAL CONTROL INPUT DATA
FOR THE ABOVE MATERIAL

```

!!!!!!!!!!!!!!!!!!!!!!!!!!!!!!!!!!!!!!!!!!!!!!!!!!!!!!!!!!!!!!!!!!!!!!!!!!!!!!
PLEASE NOTE THE FOLLOWING:
  1. TEMPERATURE DEPENDENT DATA SETS MUST BE ARRANGED IN ASCENDING ORDER
    ACCORDING TO TEMPERATURE.
  2. MAXIMUM NUMBER OF TEMPERATURE SETS IS 20.
!!!!!!!!!!!!!!!!!!!!!!!!!!!!!!!!!!!!!!!!!!!!!!!!!!!!!!!!!!!!!!!!!!!!!!!!!!!!!!

TDEG      : TEMPERATURE OF THIS SET
-----
00070.0000
-----

PARAM      : WEIBULL MODULUS (SHAPE PARAMETER) AND SCALE PARAMETER
*-WEIBULL MODULUS-*SCALE PARAMETER-*
      0.765000E+01      0.878910E+05
*-----*
                        END OF DATA FOR THE ABOVE TEMPERATURE

*****
$ENDT      : END OF DATA FOR THE ABOVE MATERIAL
*****

```

Figure 10.—Direct input of temperature-dependent statistical material parameters.

PARAM (2E18.10) PARAM signals that the Weibull shape and scale parameter will be input for the temperature indicated by TDEG. Referring to figure 10, the Weibull shape and then the Weibull scale parameters are entered at the indicated space with a format of 2E18.10. The Weibull shape parameter is dimensionless. The Weibull scale parameter has units of stress \times (volume)^{1/m_v} for volume flaw analysis and units of stress \times (area)^{1/m_s} for surface flaw analysis. Note that ID1=3 must be specified.

TDEG (F10.4) TDEG is the input keyword for the temperature of the fracture data or of the statistical material parameters that immediately follow. Temperature can be specified in any unit but must be consistent with the finite element analysis.

\$ENDT The keyword \$ENDT signals the end of the temperature-dependent data. Another section of the Material Control Input follows, if required.

Execution of the CARES Program

The CARES code requires that all input files be prepared prior to execution. To set up for execution of the program, the user must assign logical unit numbers for various files. Figure 4 shows the logical units that are required. The specific values used in the figure can be changed by reassigning the unit numbers at the section indicated near the beginning of the main program. However, the subsequent discussion uses the numbers shown in this figure. The CARES program can

be run in two modes: (1) postprocessing MSC/NASTRAN or ANSYS finite element static analysis output to predict component reliability and (2) analysis of specimen fracture stresses to determine estimates of the statistical material parameters. In both modes, logical units 5 and 1 must be assigned to the CARES input and output files, respectively. Additional logical units must be assigned for finite element postprocessing applications. For input, units 3 and 7 are used for the MSC/NASTRAN printout and punch files, respectively. Logical unit 4 is required to store the right-justified MSC/NASTRAN BULK DATA and thus is used for both input and output.

At NASA Lewis, three computer systems form the backbone of the computing environment. Number-crunching capability is provided by a CRAY X-MP supercomputer operating in batch mode. Interactive tasks are performed on either an AMDAHL mainframe running the VM/CMS operating system or on the VAXcluster using the VMS operating system. The AMDAHL and VAX serve as front-end processors to the CRAY X-MP. As indicated in figure 4, the MSC/NASTRAN code is executed on the CRAY X-MP supercomputer. MSC/NASTRAN problem preparation is done on either the AMDAHL or VAX computers, although PATRAN is only available on the VAX. Supercomputer output is returned to the appropriate front-end processor. The CARES program could be run on any of the systems; however, actual executions have only been performed on the AMDAHL and VAX systems.

At NASA Lewis, the CARES code is compiled for the AMDAHL mainframe by using a FORTRAN77 compiler with

the following command:

FORTVS CARES2 (or CARES1)

It is assumed that CARES1 or CARES2 is the filename and that FORTRAN is the filetype of the source code, containing the main program and the associated subroutines. This file must have a record length of 80 and a fixed format. The VM/CMS XEDIT command to set record length is SET LRECL N (where N is the record length), and the command to fix the file format is SET RECFM F (where F is "fixed")

and V is "variable"). The compiler creates two files with the same filename but with different filetypes. The file CARES2 LISTING is an echo of the source code and the accompanying diagnostic messages. The file CARES2 TEXT contains the compiled binary machine code. The logical units are assigned by an EXEC file. An EXEC is a file with a filetype of EXEC. It contains a series of commands that are executed when you enter the filename of the EXEC file. For details on creating an EXEC, the user should consult an appropriate reference such as the IBM CMS PRIMER. The following is a typical EXEC to set up the logical units and to execute CARES:

```
/*THIS IS AN EXEC FOR CARES*/  
SETUP FTN  
MAKEBUF  
SAY 'ENTER FN FT FM OF CARES INPUT FILE '  
  PARSE UPPER PULL FN FT FM  
  FILEDEF 5 DISK FN FT FM "( " RECFM F LRECL 80 " )"  
SAY 'ENTER FN FT FM OF CARES OUTPUT FILE '  
  PARSE UPPER PULL FN FT FM  
  FILEDEF 1 DISK FN FT FM "( " RECFM F LRECL 132 " )"  
SAY 'ASSIGN MSC/NASTRAN FILES ( "Y" OR "N" ) ? '  
  PARSE UPPER PULL MSC  
  IF MSC = 'Y '  
  THEN DO  
SAY 'ENTER FN FT FM OF NASTRAN PRINTOUT FILE '  
  PARSE UPPER PULL FN FT FM  
  FILEDEF 3 DISK FN FT FM "( " RECFM F LRECL 132 " )"  
SAY 'ENTER FN FT FM OF NASTRAN PUNCH FILE '  
  PARSE UPPER PULL FN FT FM  
  FILEDEF 7 DISK FN FT FM "( " RECFM F LRECL 80 " )"  
SAY 'ENTER FM OF BULK DATA BUFFER FILE (TBUFF CARES) '  
  PARSE UPPER PULL FM  
  FILEDEF 4 DISK TBUFF CARES FM "( " RECFM F LRECL 80 " )"  
  END  
  ELSE DO  
SAY 'NO MSC/NASTRAN FILES ARE ASSIGNED '  
  END  
SAY 'EXECUTE CARES1 OR CARES2 ( "1" OR "2" ) ? '  
  PARSE UPPER PULL VER  
  IF VER = '1 '  
  THEN DO  
SAY 'EXECUTE CARES1 '  
LOAD CARES1 "( " CLEAR START " )"  
  END  
  ELSE DO  
SAY 'EXECUTE CARES2 '  
LOAD CARES2 "( " CLEAR START " )"  
  END
```

Note that record lengths (LRECL) and record formats (RECFM) for input files must be changed, if necessary, to be consistent with the EXEC. Also note that logical unit 4 is

created with a filename of TBUFF and a filetype of CARES. This file contains the right-justified BULK DATA that CARES recognizes as input when it reads the MSC/NASTRAN punch

file. The output of the CARES analysis is contained in a file with the filename, filetype, and filemode assigned by the user.

For the VAXcluster running the VMS operating system and a FORTRAN77 compiler, the CARES program is compiled with the following Digital Control Language (DCL) command:

```
FOR/LIST CARES2 (assuming CARES2.FOR is the
filename)
```

This command creates a 'CARES2.LIS' file, for an echo of the source code and associated messages, plus a

'CARES2.OBJ' file containing the compiled object code. CARES1 is compiled in a similar fashion. Prior to execution, the subroutines must be linked as follows:

```
LINK CARES2
```

This creates a 'CARES2.EXE' file for execution. A command file similar to an EXEC can be written as follows:

```
$ ! THIS IS A VAX/VMS DCL COMMAND FILE TO ASSIGN THE LOGICAL UNITS
$ ! TO THE APPROPRIATE FILENAMES AND START EXECUTION OF CARES1 OR
$ ! CARES2
$ ! TYPE @CARES TO EXECUTE THESE COMMANDS
$ INQUIRE FILE5 "CARES Input Filename"           ! Read input filename
$ ASSIGN 'FILE5' FOR005                          ! Assign input file
$ INQUIRE FILE1 "CARES Output Filename"         ! CARES output file
$ ASSIGN 'FILE1' FORF001
$ ! Check for NASTRAN
$ INQUIRE MSC "Assign MSC/NASTRAN files ( " "Y" " or " "N" " ) ?"
$ IF " "'MSC' " .EQS. " " THEN MSC = "Y"         ! Return = "Y"
$ ! Do not assign NASTRAN files...execute CARES
$ IF .NOT. MSC THEN GOTO EXECUTE
$ INQUIRE FILE3 "MSC/NASTRAN Printout Filename"  ! Print file
$ ASSIGN 'FILE3' FOR003
$ INQUIRE FILE7 "MSC/NASTRAN Punch Filename"    ! Punch file
$ ASSIGN 'FILE7' FOR007
$ DELETE TBUFF.DAT;*                             ! Delete any previous TBUFF.DAT
$ ASSIGN TBUFF.DAT FOR004                       ! Assign temporary buffer file
$ ! All logical units have been assigned
$ EXECUTE :
$ INQUIRE VER "CARES1 OR CARES2 ( " "1" " OR " "2" " ) ?"
$ WRITE SYS$OUTPUT " "                          ! Blank line
$ WRITE SYS$OUTPUT "EXECUTION OF CARES 'VER' HAS BEGUN..."
$ RUN CARES 'VER'
$ DEASSIGN FOR005                               ! Release all logical unit assignments
$ DEASSIGN FOR001
$ IF .NOT. MSC THEN EXIT
$ DEASSIGN FOR003
$ DEASSIGN FOR007
$ DEASSIGN FOR004
$ EXIT
```

This file is named 'CARES.COM' and is executed by typing @CARES. The right-justified MSC/NASTRAN BULK DATA are contained in the file 'TBUFF.DAT', which is deleted upon subsequent executions of the command file. The file extension 'DAT' should be maintained for the data files. A more complex version of CARES.COM is provided with the CARES code and is reproduced in **Appendix C—CARES.COM**.

Output Information

MSC/NASTRAN Output Options

Nodal temperatures for transient or steady-state conditions can be obtained from MSC/NASTRAN thermal analysis. After solving for the component temperature distribution, the thermal gradients can be combined with the simultaneously applied mechanical loads to obtain a static solution (Rigid Format 47

or Solution Sequence 61) of the problem. The usual output from these solution methods includes the nodal displacements and the element stresses. Depending on the element type, normal and shear stresses in the local element or material coordinate systems are available at element corner nodes and centroids. In addition, element principal stresses are calculated for the solid and shell element corner nodes and centroids. For details and explanations of possible element stress recovery options in MSC/NASTRAN, users should consult reference 27 and the appropriate program manuals.

In addition to the displacements and stresses, a number of useful parameters such as element volumes, element areas, and component center of gravity can be calculated in MSC/NASTRAN static analysis through the parameter call feature of the program. For volume and surface flaw reliability analysis, the element volume and area calculations are essential NASTRAN output. Other required quantities are element centroidal or nodal stresses and nodal temperatures. The element stresses and the nodal temperatures from MSC/NASTRAN are routed by the user to the punch file, whereas element volumes and surface areas are listed in the program output file. Selected details of preparing a NASTRAN problem for subsequent postprocessing with CARES are given in the **Input Information** section of this manual.

CARES Output Information

The first part of the CARES output is an echo of the choices selected (or default values) from the Master Control Input. The PRINTA subroutine echoes these data. If finite element model reliability analysis will not be performed, then CARES proceeds to echo the Material Control Input by using the PRINTB subroutine. If postprocessing of an MSC/NASTRAN problem will be done, then the ELEM subroutine is called, and the results of the search of the NASTRAN punch file and the NASTRAN printout file are output. The BULK DATA are processed first, and CARES prints the number of each type of element found (HEXA, PENTA, TRIAX6, QUAD8, and TRIA6 only). All elements of the appropriate type are read and counted, regardless of whether the material will be used in the subsequent reliability calculations. The connectivity BULK DATA cards for the HEXA, PENTA, TRIAX6, QUAD8, and TRIA6 element types are reproduced in the TBUFF (temporary buffer) file, as well as all nodal temperatures and PSOLID and PSHELL cards. The information recorded in the TBUFF file is useful as a check of what CARES recognized as input data.

After the BULK DATA are processed, the element stresses are read from the punch file. The results are summarized, beginning with an echo of the TITLE and SUBTITLE statements from the MSC/NASTRAN CASE CONTROL DECK. For each element type, a table of principal stresses with appropriate element ID numbers is given. For the CARES1 version, this table contains element centroidal principal stresses. For the CARES2 version, the 27 centroidal

subelement principal stresses within each element are listed for the solid elements and the 9 subelement centroidal principal stresses are listed for the shell elements. Subelement stresses are only determined for the HEXA and QUAD8 element types; the other elements use the element centroidal principal stresses. HEXA element subvolumes are arranged so that the first nine subelements are near the element face defined by grid points G3, G4, G7, and G8. Subelement 14 is at the HEXA element centroid. Subelements 19 to 27 are adjacent to the face defined by grid points G1, G2, G5, and G6 (for MSC/NASTRAN HEXA element grid-point convention and connectivity, see reference 27). For the QUAD8 element, subelement 5 is at the element centroid.

Since in a large finite element mesh the stress output could be excessive, printed element stress tables in CARES are optional, as shown in figure 5. In addition, two element cross-reference tables are printed. The first table lists the shell element number and gives the corresponding solid element to which it is attached. The second table lists the solid element identification number and lists up to six associated shell elements (a HEXA element could have all of its six faces as external surfaces). Element areas, volumes, and temperatures are summarized in another table. The element temperatures are determined by averaging the nodal temperatures from the BULK DATA for each element. This table marks the end of the output from the ELEM subroutine. When CARES reaches the end of the ELEM subroutine, all necessary data from the MSC/NASTRAN problem have been obtained.

Following the ELEM subroutine, CARES proceeds to the PRINTB subroutine to echo the user inputs for each section of the Material Control Input. The results of the analysis of the data from the Material Control Input are output in the PRINTP subroutine. If statistical material parameters are directly input, then output pertaining to calculated values of the normalized Batdorf crack density coefficient will follow. If statistical material parameters are determined from experimental fracture data, then the output will identify the method of solution, the control index used for experimental data, the number of specimens in each batch, and the temperature of each test. In addition, the output echoes the input values of all specimen fracture stresses with proper failure mode identification. Any data value that deviates greatly from the rest of the sample is detected as an outlier, and its corresponding significance level is printed. Three levels of significance are available for outliers: 1, 5, or 10 percent. The lower the significance level, the more extreme is the deviation of the data point from the rest of the distribution. A 1-percent significance level indicates that there is a 1-in-100 chance that the data point is actually a member of the same population as the other data, assuming a normal distribution. Next, the biased and the unbiased value of the shape parameter, the specimen characteristic strength, the upper and lower bound values at 90-percent confidence level for both the shape parameter and the specimen characteristic strength, the specimen Weibull mean value, and the corresponding standard

deviation are printed for each specified temperature. For censored statistics, these values are generated first for the volume flaw analysis and subsequently for the surface flaw analysis. Not all of this information is available for all methods of material parameter estimation, and the **Program Capability and Description** section of this manual should be consulted for further information.

The Kolmogorov-Smirnov (K-S) goodness-of-fit test is done for each data point, and the corresponding K-S statistics (D^+ and D^-) and significance level are listed. Similarly, the K-S statistic D for the overall population is printed along with the significance level. This overall statistic is the absolute maximum of individual specimen data D^+ and D^- factors. For the Anderson-Darling (A-D) goodness-of-fit test, the A-D statistic A^2 is determined for the overall population and its associated significance level is printed. The lower the significance level, the worse is the fit of the experimental data to the proposed distribution. For these tests, a 1-percent level of significance indicates that there is a 1-in-100 chance that the specimen fracture data were generated from the estimated distribution.

The next table that is generated by CARES from the PRINTP subroutine contains data to construct Kanofsky-Srinivasan 90-percent confidence bands about the Weibull distribution. The table includes fracture stress data, the corresponding Weibull probability of failure values, the 90-percent upper and lower confidence band values about the Weibull line, and the median rank value for each data point. These statistical quantities are calculated with either tabular values or approximating polynomial functions. Experimental fracture data lying outside of these bands are an indication of poor fit to the Weibull distribution.

The last table from the PRINTP subroutine summarizes the material parameters used in component reliability calculations, listed as a function of temperature. These include the biased Weibull modulus, the normalized Batdorf crack density coefficient, and the material Weibull scale parameter (unit volume or unit area characteristic strength). The values given correspond to the experimental temperatures input and five additional interpolated sets of values between each input temperature. The interpolated parameters are output so that the user can check that the interpolating polynomial is calculating appropriate results. Information on the selected fracture criterion and crack shape is printed for shear-sensitive fracture models. Crack shape is not required for the shear-insensitive fracture criterion or for the PIA model, and it need not be identified for those cases.

If component reliability analysis with finite element data is being performed, then tables will be generated to summarize the reliability evaluation of each finite element. The PRINTO subroutine is responsible for this output. One table is provided for the volume flaw analysis (solid elements), and one table is given for surface flaw analysis (shell elements), as requested by the user. The tables at the end contain an element fracture analysis results summary listing each element ID number and

the corresponding element material ID, survival probability, failure probability, risk-of-rupture intensity (risk of rupture divided by element volume or area), and statistical material parameters. Following each table is a sorted list of the 15 most critical risk-of-rupture intensity values and corresponding element numbers. Also included is the probability of failure and survival for the component surface or volume, whichever is appropriate. Finally, the overall component probability of failure, as well as the component probability of survival, are printed.

Theory

The use of advanced ceramic materials in structural applications requiring high component integrity has led to the development of a probabilistic design methodology. This method combines three major elements: (1) linear elastic fracture mechanics theory that relates the strength of ceramics to the size, shape, and orientation of critical flaws; (2) extreme value statistics to obtain the characteristic flaw size distribution function, which is a material property; and (3) material microstructure. Inherent to this design procedure is that the requirement of total safety must be relaxed and that an acceptable failure probability must be specified.

The statistical nature of fracture in engineering materials can be viewed from two distinct models (ref. 43). The first was presented by Weibull and used the weakest-link theory as originally proposed by Pierce (ref. 6). The second model was also analyzed by Pierce (ref. 6) and, in addition, by Daniels (ref. 44). This second model is referred to as the "bundle" or "parallel" model. In the bundle model, a structure is viewed as a bundle of parallel fibers. Each fiber can support a load less than its breaking strength indefinitely but will break immediately under any load equal to or greater than its breaking strength. When a fiber fractures, a redistribution of load occurs and the structure may survive. Failure occurs when all of the fibers have fractured. The weakest-link model assumes that the structure is analogous to a chain with n links. Each link may have a different limiting strength. When a load is applied to the structure such that the weakest link fails, then the structure fails. Observations show that advanced monolithic ceramics closely follow the weakest-link theory (WLT). A component fails when an equivalent stress at a flaw reaches a critical value which depends on the fracture mechanics criterion, crack configuration, crack orientation, and the crack density function of the material. In comparison with the bundle model, WLT is, in most cases, more conservative.

Weibull's WLT model does not consider failure caused by purely compressive stress states. Phenomenological observations indicate that compressive stresses do not play a major role in the failure of ceramic structures since the compressive strength of brittle materials is significantly greater than their tensile strength. Consequently, failure due to predominant

compression is currently neglected in the CARES program. This is done by comparing compressive and tensile principal stresses in each element. When a principal compressive stress exceeds three times the maximum principal tensile stress in a given element, the compressive stress state predominates, and the corresponding element reliability is set equal to unity.

One of the important features of WLT is that it predicts a size effect. The number and severity of flaws present in a structure depends on the material volume and surface area. The largest flaw in a big specimen is expected to be more severe than the largest flaw in a smaller specimen. Another consequence of WLT is that component failure may not be initiated at the point of highest nominal stress (ref. 45), as would be true for ductile materials. A large flaw may be located in a region far removed from the most highly stressed zone. Therefore, the complete stress solution of the component must be considered.

Classical WLT does not predict behavior in a multiaxial stress state. A number of concepts such as the PIA, Weibull's normal stress averaging method, and Batdorf's model have been applied to account for polyaxial stress state response. Batdorf's model (ref. 17) assumes the following: (1) microcracks in the material are the cause of fracture, (2) cracks do not interact, (3) each crack has a critical stress σ_{cr} which is defined as the stress normal to the crack plane which will cause fracture, and (4) fracture occurs under combined stresses when an effective stress σ_e acting on the crack is equal to σ_{cr} . For an assumed crack shape, σ_e can be obtained through the application of a fracture criterion. These concepts are applied in the CARES code along with methods to obtain various material statistical parameters necessary for reliability analysis.

Volume Flaw Reliability

Consider a stressed component containing many flaws, and assume that failure is due to any number of independent and mutually exclusive mechanisms (links). Each link involves an infinitesimal probability of failure ΔP_{fV} . Discretize the component into n incremental links. The probability of survival P_{sV} of the i^{th} link is

$$(P_{sV})_i = 1 - (\Delta P_{fV})_i \quad (3)$$

where the subscript V denotes volume-dependent terms. The resultant probability of survival of the whole structure is the product of the individual probabilities of survival

$$\begin{aligned} P_{sV} &= \prod_{i=1}^n (P_{sV})_i = \prod_{i=1}^n [1 - (\Delta P_{fV})_i] \\ &\cong \prod_{i=1}^n \exp [-(\Delta P_{fV})_i] = \exp \left[- \sum_{i=1}^n (\Delta P_{fV})_i \right] \end{aligned} \quad (4)$$

Assume the existence of a function $N_V(\sigma)$, referred to as the crack density function, representing the number of flaws

per unit volume having a strength equal to or less than σ . In uniform tension of magnitude σ , the probability of failure of the i^{th} link, representing the incremental volume ΔV_i , is

$$(\Delta P_{fV})_i = N_V(\sigma) \Delta V_i \quad (5)$$

and substituting into equation (4), the resultant probability of survival is

$$P_{sV} = \exp [-N_V(\sigma)V] \quad (6)$$

and the probability of failure is

$$P_{fV} = 1 - \exp [-N_V(\sigma)V] \quad (7)$$

where V is the total volume. If the stress is a function of location then

$$P_{fV} = 1 - \exp \left[- \int_V N_V(\sigma) dV \right] = 1 - \exp (-B_V) \quad (8)$$

A term called the risk of rupture by Weibull and denoted by the symbol B_V is commonly used in reliability analysis. Equations similar to (7) and (8) are applicable to surface-distributed flaws where surface area replaces volume and the flaw density function is surface area dependent.

Weibull introduced a three-parameter power function for the crack density function $N_V(\sigma)$,

$$N_V(\sigma) = \left(\frac{\sigma - \sigma_{uV}}{\sigma_{oV}} \right)^{m_V} \quad (9)$$

where σ_{uV} is the threshold stress (location parameter), which is usually taken as zero for ceramics. The location parameter is the value of applied stress below which the failure probability is zero. When the location parameter is zero, the two-parameter Weibull model is obtained. The scale parameter σ_{oV} then corresponds to the stress level where 63.2 percent of specimens with unit volumes would fracture. The scale parameter has dimensions of stress \times (volume) $^{1/m_V}$, where m_V is the shape parameter (Weibull modulus) that measures the degree of strength variability and m_V is a dimensionless quantity. As m_V increases, the dispersion is reduced. For large values of m_V ($m_V > 40$), such as those obtained for ductile metals, the magnitude of the scale parameter corresponds to the material ultimate strength. These three statistical parameters are material properties, and they are temperature and processing dependent.

Three-parameter behavior is rarely observed in as-processed monolithic ceramics, and statistical estimation of the three material parameters is very involved. Therefore, the CARES program uses the two-parameter model. The subsequent reliability predictions are more conservative than for the three-

parameter model since we have taken the minimum strength of the material as zero.

The two-parameter crack density function is expressed as

$$N_V(\sigma) = \left(\frac{\sigma}{\sigma_{oV}} \right)^{m_V} = k_{wV} \sigma^{m_V} \quad (10)$$

and when equation (10) is substituted into equation (8), the failure probability becomes

$$P_{fV} = 1 - \exp \left(-k_{wV} \int_V \sigma^{m_V} dV \right) \quad (11)$$

where $k_{wV} = (\sigma_{oV})^{-m_V}$ is the uniaxial Weibull crack density coefficient. Various methods have been developed to calculate σ_{oV} and m_V for a given material by using fracture strength data from simple uniaxial specimen tests (ref. 30).

The two most common techniques for using uniaxial data to calculate P_{fV} in polyaxial stress states are the PIA method (refs. 10 and 11) and the Weibull normal tensile stress averaging method (refs. 3 and 4). In the PIA model, the principal stresses $\sigma_1 \geq \sigma_2 \geq \sigma_3$ are assumed to act independently. If all principal stresses are tensile, the probability of failure according to this approach is

$$P_{fV} = 1 - \exp \left[-k_{wV} \int_V (\sigma_1^{m_V} + \sigma_2^{m_V} + \sigma_3^{m_V}) dV \right] \quad (12)$$

Compressive principal stresses are assumed not to contribute to the failure probability. It has been shown that this equation yields nonconservative estimates of P_{fV} in comparison with the Weibull normal stress method (ref. 46).

The failure probability using the Weibull normal tensile stress averaging method, which has been described through an integral formulation (ref. 47), can be calculated from

$$P_{fV} = 1 - \exp \left(- \int_V k_{wpV} \bar{\sigma}_n^{m_V} dV \right) \quad (13)$$

where

$$\bar{\sigma}_n^{m_V} = \frac{\int_A \sigma_n^{m_V} dA}{\int_A dA}$$

The area integration is performed in principal stress space over the surface A of a sphere of unit radius for regions where σ_n , the projected normal stress on the surface, is tensile. The polyaxial Weibull crack density coefficient is k_{wpV} . The relationship between k_{wpV} and k_{wV} is found by equating the failure probability for uniaxial loading to that obtained for the

polyaxial stress state when the latter is reduced to a uniaxial condition. The result is

$$k_{wpV} = (2m_V + 1)k_{wV} \quad (14)$$

Batdorf and Crose (ref. 17) proposed a statistical theory in which attention is focused on cracks and their failure under stress. Flaws are taken to be uniformly distributed and randomly oriented in the material bulk. Fracture is assumed to depend only on the tensile stress acting normal to the crack plane; hence, shear insensitivity is inherent to the model. Subsequently, Batdorf and Heinisch (ref. 48) included the detrimental effects of shear traction on a flaw plane. Their method applies fracture mechanics concepts by combining a crack geometry and a mixed-mode fracture criterion to describe the condition for crack growth. Adopting this approach, the CARES program contains several fracture criteria and flaw shapes for volume and surface analyses (fig. 2).

Consider a small, uniformly stressed material element of volume ΔV . The incremental probability of failure under the applied state of stress Σ can be written as the product of two probabilities,

$$\Delta P_{fV}(\Sigma, \sigma_{cr}, \Delta V) = \Delta P_{1V} P_{2V} \quad (15)$$

where ΔP_{1V} is the probability of existence in ΔV of a crack having a critical stress between σ_{cr} and $\sigma_{cr} + \Delta\sigma_{cr}$. As previously noted, critical stress is defined as the remote, uniaxial fracture strength of a given crack in mode I loading. The second probability, P_{2V} , denotes the probability that a crack of critical stress σ_{cr} will be oriented in a direction such that an effective stress σ_e (which is a function of fracture criterion, stress state, and crack configuration) satisfies the condition $\sigma_e \geq \sigma_{cr}$. The effective stress is defined as the equivalent mode I stress a flaw would experience when subjected to a multiaxial stress state that results in modes I, II, and III crack surface displacements.

Crack dimensions are related to crack strength, and crack size is never explicitly used in statistical fracture theories. Batdorf and Crose (ref. 17) describe ΔP_{1V} as

$$\Delta P_{1V} = \Delta V \frac{dN_V(\sigma_{cr})}{d\sigma_{cr}} d\sigma_{cr} \quad (16)$$

and P_{2V} is expressed as

$$P_{2V} = \frac{\Omega(\Sigma, \sigma_{cr})}{4\pi} \quad (17)$$

where $N_V(\sigma_{cr})$ is the Batdorf crack density function and $\Omega(\Sigma, \sigma_{cr})$ is the area of the solid angle projected onto the unit radius sphere in principal stress space containing all the crack orientations for which $\sigma_e \geq \sigma_{cr}$. The constant 4π is the sur-

face area of a unit radius sphere and corresponds to a solid angle containing all possible flaw orientations.

The probability of survival in a volume element ΔV_i is

$$(P_{sV})_i = \exp \left\{ -\Delta V_i \left[\int_0^{\sigma_{e\max}} \frac{\Omega(\Sigma, \sigma_{cr})}{4\pi} \frac{dN_V(\sigma_{cr})}{d\sigma_{cr}} d\sigma_{cr} \right] \right\} \quad (18a)$$

where $\sigma_{e\max}$ is the maximum effective stress a randomly oriented flaw could experience from the given stress state. Hence, the component failure probability is

$$P_{fV} = 1 - \exp \left\{ - \int_V \left[\int_0^{\sigma_{e\max}} \frac{\Omega(\Sigma, \sigma_{cr})}{4\pi} \frac{dN_V(\sigma_{cr})}{d\sigma_{cr}} d\sigma_{cr} \right] dV \right\} \quad (18b)$$

The Batdorf crack density function $N_V(\sigma_{cr})$ is a material property, independent of stress state, and is usually approximated by a power function (ref. 48). This leads to the Batdorf crack density function of the form

$$N_V(\sigma_{cr}) = k_{BV} \sigma_{cr}^{m_V} \quad (19)$$

where the material Batdorf crack density coefficient k_{BV} and the Weibull modulus m_V can be evaluated from experimental fracture data. Batdorf and Crose (ref. 17) initially proposed a Taylor series expansion for $N_V(\sigma_{cr})$, but this method has computational difficulties. A more convenient integral equation approach was recently formulated and extended to the use of data from four-point MOR bar tests (ref. 41). Note that $N_V(\sigma_{cr})$ has units of inverse volume.

Although the Weibull (eq. (10)) and Batdorf (eq. (19)) crack density functions are similar in form, they are not the same. The Weibull function simply depends on the applied stress σ and is the only term other than the volume necessary to calculate P_{fV} . The Batdorf function depends on the mode I strength of the crack σ_{cr} , which is probabilistic and must be integrated over a range of values for a given stress state. Furthermore, to obtain P_{fV} , a crack orientation function, P_{2V} , must be considered in addition to the density function and the volume. Finally, the Batdorf coefficient k_{BV} cannot be calculated from uniaxial data until a fracture criterion and crack shape are chosen—in contrast to the Weibull coefficient k_{wV} , which depends only on the data.

Assuming a shear-insensitive condition, fracture occurs when $\sigma_n = \sigma_e \geq \sigma_{cr}$, where σ_n is the normal tensile stress on the flaw plane. However, it is known from fracture mechanics analysis that for a flat crack, a shear stress τ applied parallel to the crack plane (mode II or III) also contributes to fracture.

Therefore, for polyaxial stress states, expressing the effective stress σ_e as a function of both σ_n and τ is more accurate than assuming shear insensitivity. Batdorf and Heinisch (ref. 48) give effective stress expressions for two flaw shapes by using both Griffith's maximum tensile stress criterion and Griffith's total coplanar strain energy release rate criterion G_T . Arranged in order of increasing shear sensitivity, for the maximum tensile stress criterion the effective stress equations are

$$\sigma_e = \frac{1}{2} \left(\sigma_n + \sqrt{\sigma_n^2 + \tau^2} \right) \quad (20)$$

for a Griffith flaw and

$$\sigma_e = \frac{1}{2} \left\{ \sigma_n + \sqrt{\sigma_n^2 + \left[\frac{\tau}{(1-0.5\nu)} \right]^2} \right\} \quad (21)$$

for a penny-shaped flaw, where ν is Poisson's ratio.

The total coplanar strain energy release rate criterion is calculated from

$$G_T = G_I + G_{II} + G_{III} \quad (22)$$

where G is the energy release rate for various crack extension modes. In terms of stress intensity factors, the effective stress equation can be derived from (plane strain condition assumed) enforcing the condition $G_T = G_C$, where G_C is the critical strain energy release rate. Thus,

$$K_{IC}^2 = K_I^2 + K_{II}^2 + \frac{K_{III}^2}{1-\nu} \quad (23)$$

For a Griffith crack, assuming that modes I and II dominate the response with $K_I = \sigma_n \sqrt{\pi a}$ and $K_{II} = \tau \sqrt{\pi a}$, where $2a$ is the crack length, we have from equation (23)

$$\sigma_e = \sqrt{\sigma_n^2 + \tau^2} \quad (24)$$

For a penny-shaped crack at the critical point on the crack periphery, we have $K_I = 2\sigma_n \sqrt{a/\pi}$ and $K_{II} = [4\tau/(2-\nu)] \sqrt{a/\pi}$ (ref. 49), where a is now the crack radius. The resulting effective stress equation is

$$\sigma_e = \left\{ \sigma_n^2 + \left[\frac{\tau}{(1-0.5\nu)} \right]^2 \right\}^{1/2} \quad (25)$$

The equations given by Batdorf and Heinisch consider only self-similar (coplanar) crack extension. However, a flaw experiencing a multiaxial stress state usually undergoes crack propagation initiated at some angle to the flaw plane

(noncoplanar crack growth). Shetty (ref. 26) performed experiments on polycrystalline ceramics and glass where he investigated crack propagation as a function of an applied far-field multiaxial stress state. He modified an equation proposed by Palaniswamy and Knauss (ref. 25) so that it would empirically fit experimental data. This multimodal interaction equation takes the form

$$\frac{K_I}{K_{IC}} + \left(\frac{K_{II}}{\bar{C}K_{IC}} \right)^2 = 1 \quad (26)$$

where K_{δ} is either K_{II} or K_{III} , whichever is dominant, and \bar{C} is a constant adjusted to best fit the data. Shetty (ref. 26) found a range of values of $0.80 \leq \bar{C} \leq 2.0$ for the materials he tested which contained large induced flaws. As \bar{C} increases, the response becomes progressively more shear insensitive.

Using this relationship with assumed modes I and II dominance for the Griffith crack yields

$$\sigma_c = \frac{1}{2} \left[\sigma_n + \sqrt{\sigma_n^2 + \left(\frac{2\tau}{\bar{C}} \right)^2} \right] \quad (27)$$

and for a penny-shaped crack, we get

$$\sigma_e = \frac{1}{2} \left[\sigma_n + \sqrt{\sigma_n^2 + \left(\frac{4\tau}{\bar{C}(2-\nu)} \right)^2} \right] \quad (28)$$

To determine a component probability of failure from equation (18b), P_{2V} has to be evaluated for each elemental volume ΔV_i , within which a uniform stress state $\Sigma(\sigma_1, \sigma_2, \sigma_3)$ is assumed. The solid angle $\Omega(\Sigma, \sigma_{cr})$ depends on the selected fracture criterion, the crack configuration, and the applied stress state. For multiaxial stress states, with few exceptions, $\Omega(\Sigma, \sigma_{cr})$ must be determined numerically. For a sphere of unit radius (fig. 11), an elemental surface area of the sphere is $dA = \sin \alpha \, d\beta \, d\alpha$. Project onto the spherical surface the equivalent stress $\sigma_e(\Sigma, \alpha, \beta)$. The solid angle $\Omega(\Sigma, \sigma_{cr})$ is the area of the sphere containing all of the projected equivalent stresses where $\sigma_e \geq \sigma_{cr}$. Noting the symmetry of σ_e , and addressing the first octant of the unit sphere, then

$$\Omega(\Sigma, \sigma_{cr}) = 4\pi P_{2V} = 8 \int_0^{\pi/2} \left(\int d\beta \right) \sin \alpha \, d\alpha \quad (29)$$

where β is evaluated between 0 and $\pi/2$.

To obtain the limits of integration, $\bar{\beta}_1$ and $\bar{\beta}_2$, for the interval where $\sigma_e \geq \sigma_{cr}$, the principal stresses must first be transformed to normal and shear stresses. Selecting an arbitrary plane and imposing equilibrium of forces (fig. 11) yields the following equations:

$$\sigma^2 = \sigma_1^2 \ell^2 + \sigma_2^2 m^2 + \sigma_3^2 n^2 \quad (30)$$

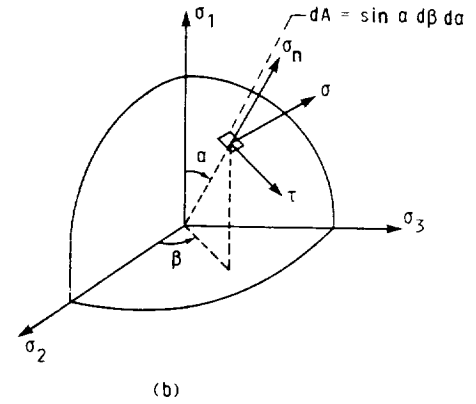
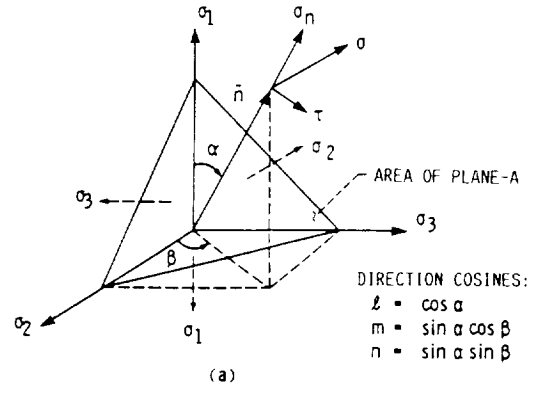

(a) In principal stress space.
(b) Projected onto a plane tangent to the unit radius sphere.

Figure 11.—Stresses on Cauchy infinitesimal tetrahedron.

$$\sigma_n = \sigma_1 \ell^2 + \sigma_2 m^2 + \sigma_3 n^2 \quad (31)$$

and

$$\tau^2 = \sigma^2 - \sigma_n^2 \quad (32)$$

where σ is the total traction vector acting on the crack plane and the direction cosines ℓ , m , and n are given in figure 11 in terms of trigonometric functions of α and β . From the selected fracture criterion and crack configuration, σ_e is obtained as a function of Σ , α , and β .

By defining $\Phi = \cos^2 \beta$ and enforcing the failure condition of $\sigma_e = \sigma_{cr}$, we obtain a quadratic equation in Φ satisfying either

$$\sigma_{cr}^2 - \left(\sigma_n^2 + D\tau^2 \right) = 0 \quad (33)$$

or

$$\left(\sigma_{cr} - \frac{\sigma_n}{2} \right)^2 - \frac{1}{4} \left(\sigma_n^2 + D\tau^2 \right) = 0 \quad (34)$$

where D is some constant defined by the specific fracture criterion and crack geometry. Equation (33) is used with the

effective stress equations (24) and (25). Equation (34) is used when the effective stress equations (20), (21), (27), and (28) are selected. The quadratic equation takes the form

$$a_1\Phi^2 + a_2\Phi + a_3 = 0 \quad (35)$$

and the roots Φ_1 and Φ_2 are

$$\Phi_{2,1} = \frac{-a_2 \pm \sqrt{a_2^2 - 4a_1a_3}}{2a_1} \quad (36)$$

where $\Phi_1 \leq \Phi_2$. The expressions for coefficients a_1 , a_2 , and a_3 are given in tables I and II.

The values for $\bar{\beta}$ are then found as

$$\left. \begin{aligned} \bar{\beta}_1 &= \cos^{-1} \sqrt{\Phi_2} & 0 \leq \Phi_2 \leq 1 \\ \bar{\beta}_1 &= 0 & \Phi_2 < 0 \text{ or } \Phi_2 > 1 \\ & & \text{or } \Phi_2 \text{ is a complex number} \\ \bar{\beta}_2 &= \cos^{-1} \sqrt{\Phi_1} & 0 \leq \Phi_1 \leq 1 \\ \bar{\beta}_2 &= \frac{\pi}{2} & \Phi_1 < 0 \text{ or } \Phi_1 > 1 \\ & & \text{or } \Phi_1 \text{ is a complex number} \end{aligned} \right\} \quad (37)$$

After obtaining $\bar{\beta}_1$ and $\bar{\beta}_2$ for a given Σ , α , and σ_{cr} , care must be taken in evaluating the integral. The solution of the integral in equation (29) is either

$$\int_0^{\bar{\beta}_1} d\beta + \int_{\bar{\beta}_2}^{\pi/2} d\beta = \bar{\beta}_1 - \bar{\beta}_2 + \frac{\pi}{2} \quad (38)$$

or

$$\int_{\bar{\beta}_1}^{\bar{\beta}_2} d\beta = \bar{\beta}_2 - \bar{\beta}_1 \quad (39)$$

The correct solution is determined by checking to see if $\sigma_e - \sigma_{cr} \geq 0$ at some angle β between 0 and $\pi/2$. With the sample point and the roots to the quadratic equation, the regions where $\sigma_e \geq \sigma_{cr}$ are determined and either equation (38) or (39) is used. In the CARES program, extensive logic has been devised to examine all possible permutations the roots and the sample point may have (including imaginary roots).

An alternative approach to calculate P_{2V} is to increment the angles α and β over the surface of a unit radius sphere. By symmetry only one octant needs to be considered. At each discrete point on the surface, the effective stress is evaluated and the associated area element is summed depending on whether $\sigma_e \geq \sigma_{cr}$. This procedure is computationally inten-

sive, and whenever possible CARES employs the more efficient approach described previously.

For a given stress state and value of σ_{cr} , α is varied from 0 to $\pi/2$ and $\Omega(\Sigma, \sigma_{cr})$ is evaluated. The values of σ_{cr} vary between 0 and $\sigma_{e_{max}}$ for the Gauss-Legendre integration used by CARES. The probability of survival in volume ΔV_i is obtained by substituting equation (19) into equation (18a) to get

$$(P_{sV})_i = \exp \left\{ -\Delta V_i m_V k_{BV} \left[\int_0^{\sigma_{e_{max}}} \frac{\Omega(\Sigma, \sigma_{cr})}{4\pi} \sigma_{cr}^{m_V-1} d\sigma_{cr} \right] \right\} \quad (40a)$$

and the component failure probability is

$$P_{fV} = 1 - \exp \left\{ -m_V k_{BV} \int_V \left[\int_0^{\sigma_{e_{max}}} \frac{\Omega(\Sigma, \sigma_{cr})}{4\pi} \sigma_{cr}^{m_V-1} d\sigma_{cr} \right] dV \right\} \quad (40b)$$

Consider the simple stress state $\sigma_1 > \sigma_2 = \sigma_3$. For this case, σ_e and $\Omega(\Sigma, \sigma_{cr})$ are independent of β and equation (29) reduces to

$$\Omega(\Sigma, \sigma_{cr}) = 8 \int_0^{\pi/2} d\beta \int_0^{\pi/2} \sin \alpha d\alpha = 4\pi \int_0^{\pi/2} \sin \alpha d\alpha \quad (41)$$

where α is integrated between 0 and $\pi/2$ in a manner similar to the integration of β in equation (29). The quadratic equation (35) is reformulated as a function of α , where now $\Phi = \cos^2 \alpha$. Table II(a) contains the coefficients a_1 , a_2 , and a_3 for calculating Φ_i and, hence, $\Omega(\Sigma, \sigma_{cr})$ for various fracture criteria and crack shapes for this stress state. The logic for evaluating the α integral is the same as that for the β integral, as described in equations (37) to (39). With the possible exception of the Shetty criterion or when $\sigma_3 < 0$, the quadratic equation can have only one root between 0 and 1, and $\Omega(\Sigma, \sigma_{cr})$ is simply $4\pi (1 - \cos \bar{\alpha})$ where $\bar{\alpha}$ corresponds to the single root. If both roots lie outside the range 0 to 1, then a sample point is required to determine whether $\Omega(\Sigma, \sigma_{cr}) = 0$ or $\Omega(\Sigma, \sigma_{cr}) = 4\pi$. Additional equations for calculating P_{2V} are also listed in table II(b) for special stress states, such as the uniaxial, equibiaxial, and equitriaxial loading conditions.

For certain stress states and crack plane orientations, the normal stress on the crack plane can be compressive. When this situation occurs in the CARES program, the normal stress is set to zero and only the shear stress is assumed to contribute to crack growth. This is generally a conservative assumption since friction between the crack faces is ignored. If friction were considered, the effective applied shear would be reduced.

TABLE I.—FORMS OF P_{2V} FOR VARIOUS FRACTURE CRITERIA AND SELECTED CRACK CONFIGURATIONS FOR VOLUME FLAW RELIABILITY ANALYSIS

$$\sigma_1 \geq \sigma_2 > \sigma_3 \quad \sigma_3 \geq 0 \quad \text{and} \quad \sigma_e = \sigma_{cr}$$

$$P_{2V} = \frac{\Omega(\Sigma, \sigma_{cr})}{4\pi} = \frac{2}{\pi} \int_0^{\pi/2} \int d\beta \sin \alpha \, d\alpha$$

where

$$\Phi_{2,1} = \cos^2 \bar{\beta}_{1,2} = \frac{-a_2 \pm \sqrt{a_2^2 - 4a_1 a_3}}{2a_1} \quad \text{or} \quad \Phi = -\frac{a_3}{a_2} \quad \text{when} \quad a_1 = 0$$

and

$$\begin{array}{l} \Phi_1 \leq \Phi_2 \\ \bar{\beta}_1(\alpha, \sigma_{cr}) = \cos^{-1} \sqrt{\Phi_2} \\ \bar{\beta}_2(\alpha, \sigma_{cr}) = \cos^{-1} \sqrt{\Phi_1} \end{array} \quad \left| \quad \bar{\beta}(\alpha, \sigma_{cr}) = \cos^{-1} \sqrt{\Phi} \right.$$

After obtaining roots for a given stress state (Σ, σ_{cr}) and varying α , care must be taken in evaluating $\int d\beta$. The relation of σ_e to σ_{cr} in the neighborhood of $\bar{\beta}$ must be known to obtain the proper limits of the integral.

$$D_1 = \frac{1}{(1 - 0.5\nu)^2} \quad D_2 = \frac{\nu(1 - 0.25\nu)}{(1 - 0.5\nu)^2} = D_1 - 1$$

Fracture criterion	Crack configuration	Quadratic equation coefficients for $\sigma_e(\Sigma, \alpha, \beta) \geq 0$	Fracture criterion	Crack configuration	Quadratic equation coefficients for $\sigma_e(\Sigma, \alpha, \beta) \geq 0$
Normal stress (shear-insensitive cracks)	Independent of crack shape	$a_1 = 0$ $a_2 = (\sigma_2 - \sigma_3) \sin^2 \alpha$ $a_3 = (\sigma_1 - \sigma_3) \cos^2 \alpha + \sigma_3 - \sigma_{cr}$	Shetty	Griffith crack (GC)	$a_1 = \frac{1}{C^2} (\sigma_2 - \sigma_3)^2 \sin^4 \alpha$ $a_2 = (\sigma_2 - \sigma_3) \sin^2 \alpha \left[-\sigma_{cr} + \frac{1}{C^2} (2\sigma_1 \cos^2 \alpha + 2\sigma_3 \sin^2 \alpha - \sigma_2 - \sigma_3) \right]$ $a_3 = \sigma_{cr}^2 - \sigma_{cr}(\sigma_1 \cos^2 \alpha + \sigma_3 \sin^2 \alpha) - \frac{1}{C^2} [(\sigma_1 - \sigma_3)^2 \sin^2 \alpha \cos^2 \alpha]$
	Maximum tensile stress	Griffith crack (GC)			
	Penny-shaped crack (PSC)	$a_1 = D_1(\sigma_2 - \sigma_3)^2 \sin^4 \alpha$ $a_2 = D_1(\sigma_2 - \sigma_3) \sin^2 \alpha \left[2(\sigma_1 \cos^2 \alpha + \sigma_3 \sin^2 \alpha) - \frac{4}{D_1} \sigma_{cr} - \sigma_3 - \sigma_2 \right]$ $a_3 = -D_1(\sigma_1 - \sigma_3)^2 \sin^2 \alpha \cos^2 \alpha - 4\sigma_{cr}(\sigma_1 \cos^2 \alpha + \sigma_3 \sin^2 \alpha) + 4\sigma_{cr}^2$		Penny-shaped crack (PSC)	$a_1 = \frac{D_1}{C^2} (\sigma_2 - \sigma_3)^2 \sin^4 \alpha$ $a_2 = (\sigma_2 - \sigma_3) \sin^2 \alpha \left[-\sigma_{cr} + \frac{D_1}{C^2} \times (2\sigma_1 \cos^2 \alpha + 2\sigma_3 \sin^2 \alpha - \sigma_2 - \sigma_3) \right]$ $a_3 = \sigma_{cr}^2 - \sigma_{cr}(\sigma_1 \cos^2 \alpha + \sigma_3 \sin^2 \alpha) - \frac{D_1}{C^2} \times [(\sigma_1 - \sigma_3)^2 \sin^2 \alpha \cos^2 \alpha]$
Strain energy release rate, G_T	Griffith crack (GC)	$a_1 = 0$ $a_2 = -(\sigma_2^2 - \sigma_3^2) \sin^2 \alpha$ $a_3 = -\sigma_1^2 \cos^2 \alpha - \sigma_3^2 \sin^2 \alpha + \sigma_{cr}^2$			
	Penny-shaped crack (PSC)	$a_1 = D_2(\sigma_2 - \sigma_3)^2 \sin^4 \alpha$ $a_2 = -D_1(\sigma_2^2 - \sigma_3^2) \sin^2 \alpha + 2D_2(\sigma_2 - \sigma_3) \sin^2 \alpha \times (\sigma_3 \sin^2 \alpha + \sigma_1 \cos^2 \alpha)$ $a_3 = -D_1(\sigma_1^2 \cos^2 \alpha + \sigma_3^2 \sin^2 \alpha) + D_2(\sigma_1 \cos^2 \alpha + \sigma_3 \sin^2 \alpha)^2 + \sigma_{cr}^2$			

TABLE II.—FORMS OF $P_{2\nu}$ FOR VARIOUS FRACTURE CRITERIA AND SELECTED CRACK CONFIGURATIONS FOR SPECIAL STRESS STATES^a

(a) $\sigma_1 > \sigma_2 = \sigma_3$, $\sigma_3 \geq 0$, and $\sigma_e = \sigma_{cr}$

$$P_{2\nu} = \frac{\Omega(\Sigma, \sigma_{cr})}{4\pi} = \int \sin \alpha \, d\alpha$$

where

$$\Phi_{2,1} = \cos^2 \bar{\alpha}_{1,2} = \frac{-a_2 \pm \sqrt{a_2^2 - 4a_1 a_3}}{2a_1} \quad \text{or} \quad \Phi = -\frac{a_3}{a_2} \quad \text{when} \quad a_1 = 0$$

and

$$\begin{array}{l} \Phi_1 \leq \Phi_2 \\ \bar{\alpha}_1(\sigma_{cr}) = \cos^{-1} \sqrt{\Phi_2} \\ \bar{\alpha}_2(\sigma_{cr}) = \cos^{-1} \sqrt{\Phi_1} \end{array} \quad \left| \quad \begin{array}{l} \bar{\alpha}(\sigma_{cr}) = \cos^{-1} \sqrt{\Phi} \end{array} \right.$$

$$D_1 = \frac{1}{(1 - 0.5\nu)^2} \quad D_2 = \frac{\nu(1 - 0.25\nu)}{(1 - 0.5\nu)^2} = D_1 - 1$$

Fracture criterion	Crack configuration	Quadratic equation coefficients for $\sigma_n(\Sigma, \alpha) \geq 0$	Fracture criterion	Crack configuration	Quadratic equation coefficients for $\sigma_n(\Sigma, \alpha) \geq 0$	
Maximum tensile stress	Griffith crack (GC)	$a_1 = (\sigma_1 - \sigma_2)^2$ $a_2 = -(\sigma_1 - \sigma_2)^2 - 4(\sigma_1 - \sigma_2)\sigma_{cr}$ $a_3 = 4\sigma_{cr}(\sigma_{cr} - \sigma_2)$	Shetty	Griffith crack (GC)	$a_1 = \frac{1}{\bar{C}^2} (\sigma_1 - \sigma_2)^2$ $a_2 = -\sigma_{cr}(\sigma_1 - \sigma_2) - \frac{1}{\bar{C}^2} (\sigma_1 - \sigma_2)^2$ $a_3 = \sigma_{cr}(\sigma_{cr} - \sigma_2)$	
	Penny-shaped crack (PSC)	$a_1 = D_1(\sigma_1 - \sigma_2)^2$ $a_2 = -D_1 \left[(\sigma_1 - \sigma_2)^2 + \frac{4}{D_1} (\sigma_1 - \sigma_2)\sigma_{cr} \right]$ $a_3 = 4\sigma_{cr}(\sigma_{cr} - \sigma_2)$		Penny-shaped crack (PSC)	$a_1 = \frac{D_1}{\bar{C}^2} (\sigma_1 - \sigma_2)^2$ $a_2 = -\sigma_{cr}(\sigma_1 - \sigma_2) - \frac{D_1}{\bar{C}^2} (\sigma_1 - \sigma_2)^2$ $a_3 = \sigma_{cr}(\sigma_{cr} - \sigma_2)$	
Strain energy release rate, G_T	Griffith crack (GC)	$a_1 = 0$ $a_2 = \sigma_2^2 - \sigma_1^2$ $a_3 = \sigma_{cr}^2 - \sigma_2^2$				
	Penny-shaped crack (PSC)	$a_1 = D_2(\sigma_1 - \sigma_2)^2$ $a_2 = -D_1(\sigma_1^2 - \sigma_2^2) + 2D_2\sigma_2(\sigma_1 - \sigma_2)$ $a_3 = \sigma_{cr}^2 - \sigma_2^2$				

^aNote: CARES defaults to shear-insensitive crack for uniaxial loading when $IKBAT = 0$.

ORIGINAL PAGE IS
OF POOR QUALITY

TABLE II.—Concluded.

 (b) $\sigma_3 > 0$

$$P_{2V} = \frac{\Omega(\Sigma, \sigma_{cr})}{4\pi}$$

Fracture criterion	Crack configuration	Stress state	P_{2V}	Fracture criterion	Crack configuration	Stress state	P_{2V}
Normal stress (shear-insensitive cracks)	Independent of crack shape	$\sigma_2 = \sigma_3$ $\sigma_1 \neq \sigma_2$	$\frac{\Omega}{4\pi} = 1 - \cos \alpha = 1 - \sqrt{\Phi}$ where $\Phi = \cos^2 \bar{\alpha} = \frac{\sigma_{cr} - \sigma_2}{\sigma_1 - \sigma_2}$	Strain energy release rate, G_T	Griffith crack (GC)	Uniaxial $\sigma_1 = \sigma$ $\sigma_2 = \sigma_3 = 0$	$\frac{\Omega}{4\pi} = 1 - \frac{\sigma_{cr}}{\sigma}$
		Equibiaxial $\sigma_1 = \sigma_2 = \sigma$ $\sigma_3 = 0$	$\frac{\Omega}{4\pi} = \sqrt{1 - \left(\frac{\sigma_{cr}}{\sigma}\right)^2}$				
		Uniaxial $\sigma_1 = \sigma$ $\sigma_2 = \sigma_3 = 0$	$\frac{\Omega}{4\pi} = 1 - \cos \alpha = 1 - \sqrt{\Phi}$ where $\Phi = \cos^2 \bar{\alpha} = \frac{\sigma_{cr}}{\sigma}$	Independent of fracture criterion	Independent of crack shape	Equitriaxial $\sigma_1 = \sigma_2 = \sigma_3 = \sigma$	$\frac{\Omega}{4\pi} = 1.0$
		Equibiaxial $\sigma_1 = \sigma_2 = \sigma$ $\sigma_3 = 0$	$\frac{\Omega}{4\pi} = \sqrt{1 - \frac{\sigma_{cr}}{\sigma}}$				

*Note: CARES defaults to shear-insensitive crack for uniaxial loading when $IKBAT = 0$.

For most fracture criteria and stress states, $\sigma_{e_{max}} = \sigma_1$; that is, the maximum effective stress is equal to the maximum tensile principal stress. For the noncoplanar crack extension equations (27) and (28), if $1/\bar{C}$ and $2/\bar{C}(2 - \nu)$ are ≤ 1.0 , respectively, then $\sigma_{e_{max}} = \sigma_1$. If these terms are greater than 1, then $\sigma_{e_{max}} > \sigma_1$ is possible. Also $\sigma_{e_{max}} > \sigma_1$ is possible when $\sigma_3 < 0$. For these conditions, the values of $\bar{\beta}$ for equation (37) are found by a surface element sampling scheme.

For the special case of shear insensitivity, the projected equivalent stress on a unit radius sphere is equal to the normal stress; that is, $\sigma_e = \sigma_n$. Substituting for σ_n , we obtain

$$\sigma_e = \sigma_3 + (\sigma_1 - \sigma_3)\cos^2\alpha + (\sigma_2 - \sigma_3)\cos^2\beta \sin^2\alpha \quad (42)$$

The value of $\bar{\beta}$ satisfying $\sigma_e - \sigma_{cr} = 0$ is obtained by defining $\Phi = \cos^2\beta$ and calculating the coefficients a_i for equation (35). For this shear-insensitive case, we get

$$\left. \begin{aligned} a_1 &= 0 \\ a_2 &= (\sigma_2 - \sigma_3) \sin^2\alpha \\ a_3 &= (\sigma_1 - \sigma_3) \cos^2\alpha + \sigma_3 - \sigma_{cr} \end{aligned} \right\} \quad (43)$$

We can now solve for Φ to obtain

$$\Phi = \frac{-a_3}{a_2} = \frac{\sigma_{cr} - \sigma_3 - (\sigma_1 - \sigma_3) \cos^2\alpha}{(\sigma_2 - \sigma_3) \sin^2\alpha} \quad (44)$$

It is obvious that only one value of Φ satisfies equation (44), from which the limits of integration become

$$\left. \begin{aligned} \bar{\beta}_1 &= 0 \\ \bar{\beta}_2 &= \cos^{-1} \sqrt{\Phi} \quad \text{if } 0 \leq \Phi \leq 1 \\ \bar{\beta}_2 &= 0 \quad \text{if } \Phi > 1 \\ \bar{\beta}_2 &= \frac{\pi}{2} \quad \text{if } \Phi \leq 0 \end{aligned} \right\} \quad (45)$$

and equation (39) is used for all cases.

For a stressed component the probability of failure is calculated from equation (40b). The finite element method enables discretization of the component into incremental volume elements ΔV . In the CARES1 program, each ΔV_i corresponds to the i^{th} finite element. In the CARES2 program, each ΔV_i corresponds to the i^{th} subelement, where each three-dimensional brick finite element is subdivided into 27 subvolumes with interpolated stress states. The stress state in each subelement is assumed to be uniform. Discretizing equation (40b) results in the finite element model component failure probability equation for volume flaws:

$$P_{fV} = 1 - \exp \left\{ -\frac{m_V k_{BV}}{4\pi} \sum_{i=1}^n \left[\Delta V \int_0^{\sigma_{e_{max}}} \Omega(\Sigma, \sigma_{cr}) \sigma_{cr}^{m_V-1} d\sigma_{cr} \right]_i \right\} \quad (46)$$

where the model consists of n elements. Note that for CARES1, n is the number of elements, whereas in CARES2, n equals the number of subelements. Each element or subelement can have a unique stress state and volume. If m_V and k_{BV} are element dependent, they would appear inside the square brackets.

Surface Flaw Reliability

For surface flaw analysis (ref. 29), many of the equations from the **Volume Flaw Reliability** section remain the same, except that the statistical material parameters are a function of surface area instead of volume and the equivalent stresses are projected onto the contour of a circle of unit radius rather than onto the surface of a unit radius sphere. The cracks are assumed to be randomly oriented in the plane of the external boundary with their planes normal to the surface.

For surface-flaw-induced failure in ceramic structures, the probability of failure for the two-parameter Weibull distribution, which is analogous in form to equation (11), is

$$P_{fS} = 1 - \exp \left(-k_{wS} \int_A \sigma^{mS} dA \right) \quad (47)$$

where, $k_{wS} = (1/\sigma_{oS})^{mS}$, the Weibull surface crack density coefficient. The subscript S denotes the terms that are surface area dependent. Here σ_{oS} is the surface scale parameter with units of stress \times (area)^{1/ m_S} , and A is the stressed surface area. For biaxial stress states, the Weibull distribution in combination with the PIA hypothesis yields

$$P_{fS} = 1 - \exp \left[-k_{wS} \int_A (\sigma_1^{mS} + \sigma_2^{mS}) dA \right] \quad (48)$$

where σ_1 and σ_2 are the principal tensile in-plane stresses acting on the surface of the structure. For the Weibull normal stress averaging method, the failure probability is expressed as

$$P_{fS} = 1 - \exp \left(-k_{wpS} \int_A \bar{\sigma}_n^{mS} dA \right) \quad (49)$$

where

$$\bar{\sigma}_n^{mS} = \frac{\int_c \sigma_n^{mS} dc}{\int_c dc}$$

Here k_{wpS} is the polyaxial Weibull crack density coefficient for surface flaws. The line integration is performed over the contour c of a unit radius circle where the projected normal stress σ_n is tensile. The relationship of k_{wpS} to k_{wS} is obtained by carrying out the integration in equation (49) for a uniaxial

stress and equating the resultant failure probability to that of equation (47) (ref. 30). This results in

$$k_{wpS} = \frac{m_S \Gamma(m_S) \sqrt{\pi}}{\Gamma\left(m_S + \frac{1}{2}\right)} k_{wS} \quad (50)$$

where Γ is the gamma function. Equation (49) is the shear-insensitive case of the more general Batdorf polyaxial model.

For mixed-mode fracture due to surface flaws, the Batdorf polyaxial failure probability equation (analogous to eq. (18b)) is

$$P_{fS} = 1 - \exp \left[- \int_A \int_0^{\sigma_{cmax}} \frac{\omega(\Sigma, \sigma_{cr})}{2\pi} \frac{dN_S(\sigma_{cr})}{d\sigma_{cr}} d\sigma_{cr} dA \right] \quad (51)$$

where

$$\Delta P_{1S} = \Delta A \frac{dN_S(\sigma_{cr})}{d\sigma_{cr}} d\sigma_{cr}$$

and

$$P_{2S} = \frac{\omega(\Sigma, \sigma_{cr})}{2\pi}$$

For randomly oriented cracks, $\omega(\Sigma, \sigma_{cr})$ is the total arc length on a unit radius circle in principal stress space on which the projection of the equivalent stress satisfies $\sigma_e \geq \sigma_{cr}$, and 2π is the total arc length of the circle. As for volume flaws, the Batdorf crack density function is approximated by the power function,

$$N_S(\sigma_{cr}) = k_{BS} \sigma_{cr}^{mS} \quad (52)$$

where k_{BS} is the Batdorf surface crack density coefficient.

Fracture occurs when the equivalent stress $\sigma_e \geq \sigma_{cr}$. For the shear-insensitive case, fracture depends only on the value of the normal tensile stress such that $\sigma_e = \sigma_n$. For shear-sensitive cracks and colinear crack extension (G_T criterion), assuming a Griffith crack with $K_I = \sigma_n \sqrt{\pi a}$ and $K_{II} = \tau \sqrt{\pi a}$, we obtain as before

$$\sigma_e = \sqrt{\sigma_n^2 + \tau^2} \quad (53a)$$

whereas for a Griffith notch subjected to plane strain conditions with $K_I = 1.1215 \sigma_n \sqrt{\pi a}$ and $K_{III} = \tau \sqrt{\pi a}$ (ref. 49), we get

$$\sigma_e = \sqrt{\sigma_n^2 + \frac{0.7951}{(1-\nu)} \tau^2} \quad (53b)$$

Note that the equivalent stress for the Griffith crack is dependent on modes I and II, whereas the equivalent stress for the Griffith notch is dependent on modes I and III (ref. 29).

For noncoplanar crack growth, from equation (26) the effective stress equations for the Griffith crack and Griffith notch, respectively, are

$$\sigma_e = \frac{1}{2} \left[\sigma_n + \sqrt{\sigma_n^2 + 4 \left(\frac{\tau}{\bar{C}} \right)^2} \right] \quad (54)$$

and

$$\sigma_e = \frac{1}{2} \left[\sigma_n + \sqrt{\sigma_n^2 + 3.1803 \left(\frac{\tau}{\bar{C}} \right)^2} \right] \quad (55)$$

For a semicircular surface crack, $K_I = 1.366\sigma_n\sqrt{a}$, $K_{II} = 1.241\tau\sqrt{a}$, and $K_{III} = 0.133\tau\sqrt{a}$ (refs. 50 and 51). Since the contribution of K_{III} is small, it is neglected, and thus the effective stress for this case is

$$\sigma_e = \frac{1}{2} \left[\sigma_n + \sqrt{\sigma_n^2 + 3.301 \left(\frac{\tau}{\bar{C}} \right)^2} \right] \quad (56)$$

For the same stress state and identical \bar{C} , the Griffith crack is the most shear sensitive, whereas the Griffith notch and the semicircular crack give almost identical predictions.

The solution procedure for $\omega(\Sigma, \sigma_{cr})$ is similar to the methods outlined for volume flaw analysis in the **Volume Flaw Reliability** section. The probability that the crack orientation is such that $\sigma_e \geq \sigma_{cr}$ can be calculated from

$$P_{2S} = \frac{\omega(\Sigma, \sigma_{cr})}{2\pi} = \frac{2}{\pi} \int d\alpha \quad (57)$$

where over the unit radius circle, $0 \leq \bar{\alpha}_i \leq \pi/2$. The limits of integration are obtained through the enforcement of the failure condition $\sigma_e = \sigma_{cr}$. The required normal and shear stresses are calculated from force equilibrium on a crack plane. As shown in figure 12, the stress vector σ , the normal stress σ_n , and the shear stress τ can be expressed as

$$\sigma^2 = (\sigma_1^2 - \sigma_2^2) \cos^2\alpha + \sigma_2^2 \quad (58)$$

$$\sigma_n = (\sigma_1 - \sigma_2) \cos^2\alpha + \sigma_2 \quad (59)$$

$$\tau^2 = \sigma^2 - \sigma_n^2 = (\sigma_1 - \sigma_2)^2 \cos^2\alpha (1 - \cos^2\alpha) \quad (60)$$

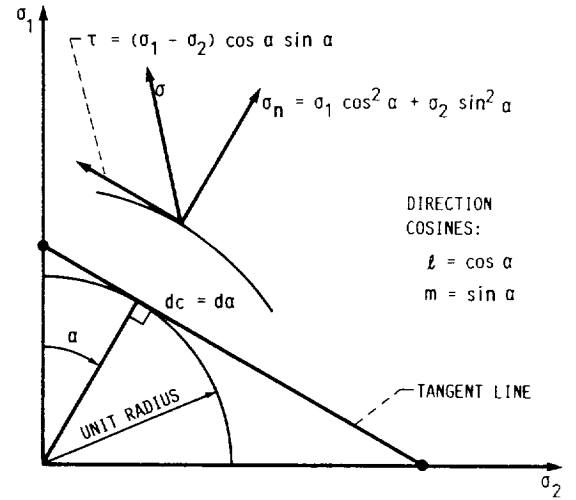

Figure 12.—Normal and shear stress as a function of α projected onto a tangent line to the unit radius circle.

Upon substitution of σ_n and τ , and satisfaction of $\sigma_e = \sigma_{cr}$, equations (53) to (56) are reduced to a quadratic expression of the same form as equation (35) with $\Phi = \cos^2\alpha$. However, since $\beta = 0^\circ$ (fig. 11(a)) in the σ_1 - σ_2 plane, the constants a_1 , a_2 , and a_3 depend only on the two principal stresses, σ_{cr} , and in some cases on the Poisson's ratio. Using the solution methods outlined in the **Volume Flaw Reliability** section, we obtain the roots of the quadratic equation. These values are given in table III along with the coefficients a_i . For cases where the roots (Φ_i) of the quadratic equation are not between 0 and 1, the calculation of P_{2S} in equation (57) follows the same logic as has been given in equations (37) to (39), with $\bar{\alpha}$ replacing $\bar{\beta}$. Specific examples for this situation have been given in reference 29. For the equibiaxial surface stress state, we always have $\omega/2\pi = 1$ for $\sigma_{cr} \leq \sigma_e$, since the in-plane shear stress is zero, and hence $\sigma_{e_{max}} = \sigma_1$ for all values of α and for any effective stress equation.

When the normal stress is compressive ($\sigma_n < 0$), it is equated to zero and the shear stress alone contributes to crack growth. The maximum equivalent stress $\sigma_{e_{max}}$ for most cases is equal to σ_1 , the maximum principal stress. However, for the noncoplanar crack extension, equation (26), $\sigma_{e_{max}}$ is dependent on the value of \bar{C} and may exceed σ_1 . Also when $\sigma_2 < 0$, then $\sigma_{e_{max}} > \sigma_1$ is possible. Again a sampling scheme is used within CARES to evaluate $\omega(\Sigma, \sigma_{cr})$ when these conditions occur.

For a finite element model and using equations (51) and (52), the probability of failure is expressed as

$$P_{fS} = 1 - \exp \left\{ -\frac{m s k_{BS}}{2\pi} \sum_{i=1}^n \left[\Delta A \int_0^{\sigma_{e_{max}}} \omega(\Sigma, \sigma_{cr}) \sigma_{cr}^{mS-1} d\sigma_{cr} \right]_i \right\} \quad (61)$$

TABLE III.—FORMS OF P_{2S} FOR VARIOUS FRACTURE CRITERIA AND SELECTED CRACK CONFIGURATIONS FOR SURFACE FLAW RELIABILITY ANALYSIS

$$\sigma_1 > \sigma_2 \quad \sigma_2 > 0 \quad \sigma_3 = 0 \quad \sigma_e = \sigma_{cr}$$

$$P_{2S} = \frac{\omega(\Sigma, \sigma_{cr})}{2\pi} = \frac{2}{\pi} \int d\alpha$$

where

$$\Phi_{2,1} = \frac{-a_2 \pm \sqrt{a_2^2 - 4a_1a_3}}{2a_1} \quad \text{or} \quad \Phi = -\frac{a_3}{a_2} \quad \text{when} \quad a_1 = 0$$

and

$$\begin{array}{l} \Phi_1 \leq \Phi_2 \\ \bar{\alpha}_1(\sigma_{cr}) = \cos^{-1} \sqrt{\Phi_2} \\ \bar{\alpha}_2(\sigma_{cr}) = \cos^{-1} \sqrt{\Phi_1} \end{array} \quad \left| \quad \begin{array}{l} \bar{\alpha}(\sigma_{cr}) = \cos^{-1} \sqrt{\Phi} \end{array} \right.$$

After obtaining roots for a given stress state Σ and σ_{cr} , care must be taken in evaluating $\int d\alpha$. The relation of σ_e to σ_{cr} in the neighborhood of $\bar{\alpha}$ must be known to obtain the proper limits of the integral.

$$D_3 = \frac{1}{1 - \nu}$$

Fracture criterion ^a	Crack configuration	Quadratic equation coefficients for $\sigma_n(\Sigma, \alpha) \geq 0$	Fracture criterion	Crack configuration	Quadratic equation coefficients for $\sigma_n(\Sigma, \alpha) \geq 0$
Normal stress (shear-insensitive cracks)	Independent of crack shape	$a_1 = 0$	Shetty	Griffith crack (GC)	$a_1 = \frac{1}{\bar{C}^2} (\sigma_1 - \sigma_2)^2$
		$a_2 = \sigma_1 - \sigma_2$			$a_2 = -\sigma_{cr} (\sigma_1 - \sigma_2) - \frac{1}{\bar{C}^2} (\sigma_1 - \sigma_2)^2$
		$a_3 = \sigma_2 - \sigma_{cr}$			$a_3 = \sigma_{cr} (\sigma_{cr} - \sigma_2)$
Strain energy release rate, G_T	Griffith crack (GC)	$a_1 = 0$	Griffith notch (GN)	Griffith notch (GN)	$a_1 = \frac{1}{(1.1215\bar{C})^2} (\sigma_1 - \sigma_2)^2$
	Griffith notch (GN)	$a_2 = \sigma_2^2 - \sigma_1^2$			$a_2 = -\sigma_{cr}(\sigma_1 - \sigma_2) - \frac{1}{(1.1215\bar{C})^2} (\sigma_1 - \sigma_2)^2$
		$a_3 = \sigma_{cr}^2 - \sigma_2^2$			$a_3 = \sigma_{cr}(\sigma_{cr} - \sigma_2)$
		$a_1 = (\sigma_1 - \sigma_2)^2 \left[\frac{D_3}{(1.1215)^2} - 1 \right]$			$a_1 = \left(\frac{0.9085}{\bar{C}} \right)^2 (\sigma_1 - \sigma_2)^2$
		$a_2 = -2\sigma_2(\sigma_1 - \sigma_2) - \frac{D_3}{(1.1215)^2} (\sigma_1 - \sigma_2)^2$			$a_2 = -\sigma_{cr}(\sigma_1 - \sigma_2) - \left(\frac{0.9085}{\bar{C}} \right)^2 (\sigma_1 - \sigma_2)^2$
		$a_3 = \sigma_{cr}^2 - \sigma_2^2$		Semicircular crack	$a_3 = \sigma_{cr}(\sigma_{cr} - \sigma_2)$

^aFor cases where neither Φ_1 nor Φ_2 is between 0 and 1, see ref. 29.

This model consists of n elements or subelements, each having an associated stress state and area. If m_s and k_{BS} are element dependent, they would appear inside the square brackets.

Estimation of Statistical Material Strength Parameters

Selected statistical theories and equations for parameter estimation are explained in detail in reference 30. The following is a brief description of these methods and how they are used in the CARES code. Typically for brittle materials, the Weibull parameters are determined from simple specimen geometry and loading conditions, such as beams under flexure and either cylindrical or flat specimens under uniform uniaxial tension. The flexural test failure probability can be expressed in terms of the extreme fiber fracture stress σ_f or modulus of rupture MOR by using the two-parameter Weibull form as

$$P_f = 1 - \exp(-C\sigma_f^m) = 1 - \exp\left[-C(MOR)^m\right] \\ = 1 - \exp\left[-\left(\frac{MOR}{\sigma_\theta}\right)^m\right] \quad (62)$$

where m is the volume or area Weibull modulus, C is the modified Weibull parameter ($C = (1/\sigma_\theta^m)$), and σ_θ is the volume or area specimen characteristic strength or the characteristic modulus of rupture MOR_θ . For uniform uniaxial tension tests, σ_f in equation (62) would just be replaced by σ_1 . The Weibull scale parameter σ_θ , as defined in equations (9) and (47) for volume and surface cracks, respectively, is determined from σ_θ , m , the specimen geometry, and the loading configuration. The scale parameter σ_θ is based on a unit volume or area, whereas σ_θ includes the effects of the specimen dimensions. The characteristic strength σ_θ is defined as the uniform stress or extreme fiber stress at which the probability of failure is 0.632.

Before computing the estimates of the statistical material parameters, it is essential to carefully examine the available specimen data to screen them for outliers. Very often, a data set may contain one or more values which may not belong to the overall population. The statistical procedures to detect the outliers at different significance levels are explained in references 30 and 34. The outlier test assumes that the data are normally distributed and from a complete sample. Therefore, the application of this test to the Weibull distribution and censored statistics is only approximate.

Various methods are available to estimate the statistical material parameters from experimental data for the two-parameter Weibull distribution. The success of the statistical approach depends on how well the probability density function fits the data. Two popular techniques used to evaluate the characteristic strength and shape parameter (σ_θ and m) are the least-squares analysis and the maximum likelihood method. Least-squares analysis is a special case of the maximum

likelihood method where the error is normally distributed and has a zero mean and constant variance. The least-squares method is not suitable for calculating confidence intervals and unbiasing factors, which quantify the statistical uncertainties in the available data.

Equation (62) can be linearized by taking the natural logarithm twice yielding

$$\ln \left[\ln \left(\frac{1}{P_f} \right) \right] = \ln \left[\ln \left(\frac{1}{1 - P_f} \right) \right] = \ln C + m \ln \sigma_f \quad (63)$$

For the least-squares analysis, it is necessary to obtain the line of best fit with slope m and an intercept b which, as seen in equation (63), is equal to the natural log of C . The failure probability P_f is determined by conducting fracture tests on N specimens. The fracture stresses are ranked such that $\sigma_{f1} < \sigma_{f2} < \dots < \sigma_{fi} < \dots < \sigma_{fN}$. For median rank regression analysis, the probability of failure of a specimen with rank i is

$$P_f(\sigma_{fi}) = \frac{i - 0.3}{N + 0.4} \quad (64)$$

By taking the partial derivative of the sum of the squared residuals with respect to m and C , and by equating the derivatives to zero, values of m and C can be estimated.

With censored data, one cannot directly use the median rank regression analysis as given in equation (64) because of the competing failure modes. To take into account the influence of the suspended items, Johnson (ref. 37) developed the rank increment technique. For this technique, all observed fracture stresses are arranged in ascending order, and rank increment values are calculated for each failure stress from the following equation:

Rank increment =

$$\frac{(N + 1) - (\text{previous adjusted rank})}{1 + (\text{number of items beyond present suspended item})} \quad (65)$$

In the CARES program for volume flaw analysis, all fracture stresses designated as V 's are considered as failure data; for surface flaw analysis, the S 's are considered as failure data. The new adjusted rank values are obtained by adding the rank increment value to the previously adjusted rank. These adjusted rank values and the median rank regression analysis (i.e., eq. (64)) are then used to calculate the failure probability P_f . Finally, the estimated Weibull parameters \hat{m} and \hat{C} are obtained.

Since the distribution of errors from the data is not normal, the maximum likelihood method is often preferred in Weibull analysis. This method has certain inherent properties. The likelihood equation from which the maximum likelihood estimates (MLE's) are obtained will have a unique solution. In addition, as the sample size increases, the solution converges to the true values of the parameters. Another feature of the maximum likelihood method is that there are no ranking functions or linear regression analysis when complete or censored samples are analyzed. The likelihood equation for a complete sample is given by

$$L = \prod_{i=1}^N \left(\frac{m}{\sigma_{\theta}} \right) \left(\frac{\sigma_{f_i}}{\sigma_{\theta}} \right)^{m-1} \exp \left[- \left(\frac{\sigma_{f_i}}{\sigma_{\theta}} \right)^m \right] \quad (66)$$

The values of m and σ_{θ} , which maximize the likelihood function L , are determined by taking the partial derivative of the logarithm of the likelihood function with respect to m and σ_{θ} . The values of \hat{m} and $\hat{\sigma}_{\theta}$ are obtained by equating the resulting expressions to zero and solving the simultaneous equations with the Newton-Raphson iterative technique. The MLE of m and σ_{θ} are designated by \hat{m}_V and $\hat{\sigma}_{\theta V}$ and by \hat{m}_S and $\hat{\sigma}_{\theta S}$ for volume flow analysis and surface flow analysis, respectively. For censored statistics we have

$$\frac{\sum_{i=1}^N (\sigma_{f_i})^{\hat{m}} \ln(\sigma_{f_i})}{\sum_{i=1}^N (\sigma_{f_i})^{\hat{m}}} - \frac{1}{r} \sum_{i=1}^r \ln(\sigma_{f_i}) - \frac{1}{\hat{m}} = 0 \quad (67)$$

and

$$\hat{\sigma}_{\theta} = \left(\frac{\sum_{i=1}^N \sigma_{f_i}^{\hat{m}}}{r} \right)^{1/\hat{m}} \quad (68)$$

where r is the number of remaining specimens failed by the flaw mode for which parameters are being calculated. For a complete (uncensored) sample, r is replaced by N , which is the total size of the sample.

The MLE of the shape parameter is always a biased estimate that depends on the number of specimens in the sample. Unbiasing of the shape parameter estimate is desired to minimize the deviation between the sample and the true population. The unbiased estimate of m is obtained by multiplying the biased estimate with an unbiasing factor (ref. 38). The confidence intervals for complete samples can also be obtained (ref. 38). For censored samples, a rigorous method for obtaining confidence intervals has not yet been developed because of the complexity of competing failure modes.

Confidence bounds for censored statistics are instead estimated in the CARES code from the factors obtained from complete samples (ref. 30). Confidence bounds enable the user to estimate the uncertainty in the parameters as a function of the number of specimens. Bounds at a 90-percent confidence level, and therefore at 5 and 95 percentage points of distribution of the MLE's of the parameters, have been incorporated into the CARES program, with data taken from reference 38.

Subjective judgement is needed to test the goodness of fit of the data to the assumed distribution. When graphical techniques are used, it can be very difficult to decide if the hypothesized distribution is valid, especially for small sample sizes. Therefore, many statistical tests have been developed to quantify the degree of correlation of the experimental data to the proposed distribution.

In general, a statistic is a numerical value computed from a random sample of the total population. The difference between an empirical distribution function (EDF) and a hypothesized distribution function is called an EDF statistic. There are two major classes of EDF statistics, and they differ in the manner in which the functional (vertical) difference between the EDF and the proposed distribution function $F(x)$ is considered. The Kolmogorov-Smirnov (K-S) goodness-of-fit statistic D belongs to the supremum class and is very effective for small samples. It uses the largest vertical difference between the two distribution functions to determine the goodness of fit. For the K-S test, the sample is arranged in ascending order, and the empirical distribution function $F_N(x)$ is a step function obtained from the following expressions:

$$\left. \begin{aligned} F_N(x) &= 0 & x < X_1 \\ F_N(x) &= \frac{i}{N} & X_i \leq x < X_{i+1} \text{ and } i = 1, 2, \dots, N-1 \\ F_N(x) &= 1 & X_N \leq x \end{aligned} \right\} \quad (69)$$

where $X_1 < X_2 < \dots < X_i \dots < X_N$ are the ordered fracture stresses from a sample of size N . The statistic D is obtained by initially evaluating two other statistics, D^+ and D^- (the largest vertical differences when $F_N(x)$ is greater than $F(x)$ and the largest vertical differences when $F_N(x)$ is smaller than $F(x)$, respectively). All three statistics are calculated by using the following expressions:

$$\left. \begin{aligned} D^+ &= \left| \frac{i}{N} - F(x)_i \right| \\ D^- &= \left| F(x)_i - \frac{i-1}{N} \right| & i = 1, 2, \dots, N \\ D &= \max(D^+, D^-) \end{aligned} \right\} \quad (70)$$

For ceramics design, the $F(x)_i$'s are equal to P_f 's and are calculated from equation (62).

On the other hand, the Anderson-Darling statistic A^2 belongs to the quadratic class and is a more powerful goodness-of-fit statistic. It evaluates the discrepancy between the two distributions through squared differences and the use of an appropriate weighting function. The statistic A^2 is given by

$$A^2 = -N - \left(\frac{1}{N}\right) \sum_{i=1}^N (2i-1) \left\{ \ln[Z_{(i)}] + \ln[1 - Z_{(N+1-i)}] \right\} \quad (71)$$

In this case, Z_i 's are the predicted failure probabilities obtained from equation (62). Corresponding significance levels α are calculated from the D and A^2 statistics. From previous surveys (ref. 30) there is no specific mention of an absolute accepted significance level. Therefore, the user must be subjective, using his or her own judgement in either accepting or rejecting the hypothesis that the data fit a Weibull distribution. However, a higher value of α indicates that the data fit the proposed distribution to a greater extent.

For complete samples, the 90-percent Kanofsky-Srinivasan confidence band values about the proposed distribution are also calculated to ascertain the fit of the data. These values are similar to the K-S statistic D centered around the EDF. The bands are generated by

$$\text{Confidence bands} = [F(x) - K(N), F(x) + K(N)] \quad (72)$$

where $F(x)$ is the failure probability obtained by substituting the Weibull parameters in equation (62). The Kanofsky functions, denoted by $K(N)$, are described in reference 52.

Some limitations are intrinsic to a purely statistical approach to design. One problem occurs when the design stress is well below the range of experimental data as shown in figure 13. Extrapolation of the Weibull distribution into this regime may yield erroneous results if other phenomena are present. When two flaw populations exist concurrently, but only one (population A) is active in the strength regime tested, the predicted failure probability may be incorrect. Furthermore, if the threshold strength is not zero, the strength may be underestimated. Finally, an approach based only on statistics can allow for stress state effects only in an empirical fashion.

Material Strength Characterization

Ceramic strength is an ambiguous property since, for brittle materials, tensile strength, compressive strength, shear strength, flexural strength, and theoretical strength all have unique meanings and different values. The theoretical strength is defined as the tensile stress required to break atomic bonds, which typically ranges from $1/10^{\text{th}}$ to $1/5^{\text{th}}$ of the elastic modulus for ceramic materials. Because of processing flaws, this strength is never obtained. A much more meaningful strength

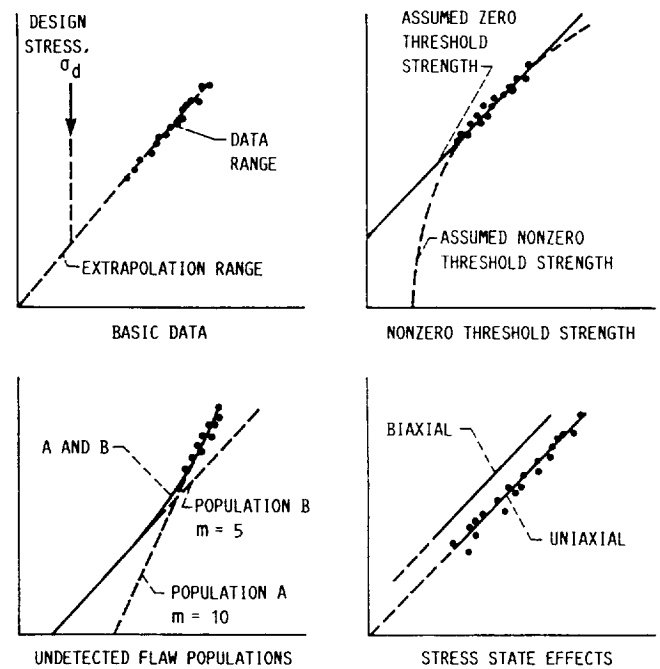

Figure 13.—Limitations of experimental data extrapolation and statistical approach to design.

measurement is the tensile strength in uniaxial tension or flexural testing. In flexural strength testing the bend strength σ_f of a ceramic is defined as the maximum tensile stress in the extreme fiber of a beam specimen (modulus of rupture, MOR). The main objective of the CARES program is to characterize ceramic strength in terms of the MOR or pure uniaxial strength and to use this information with appropriate analysis to predict component response under complex multi-axial stress states. The CARES program calculates required polyaxial statistical material strength parameters from uniaxial tensile specimen or four-point bend specimen fracture data. After evaluating the initial parameters as described in the **Estimation of Statistical Material Strength Parameters** section, additional calculations are performed to determine the material scale parameter and Batdorf crack density coefficient for use in the subsequent reliability calculations.

For volume flaw analysis of four-point MOR bar data with known geometry (fig. 14), the values of C_V and m_V in equation (62) are obtained from the least-squares or maximum likelihood analysis. The tensile stress distribution in a four-point bend specimen is

$$\left. \begin{aligned} \sigma_x &= \frac{4xy\sigma_f}{(L_1 - L_2)h} & 0 \leq x \leq \frac{L_1 - L_2}{2} \\ \sigma_x &= \frac{2y\sigma_f}{h} & \frac{L_1 - L_2}{2} \leq x \leq \frac{L_1 + L_2}{2} \\ \sigma_x &= \frac{4(L_1 - x)y\sigma_f}{(L_1 - L_2)h} & \frac{L_1 + L_2}{2} \leq x \leq L_1 \end{aligned} \right\} \quad (73)$$

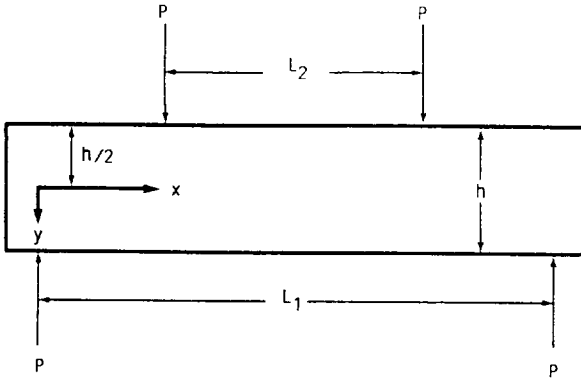

Figure 14.—Four-point bend specimen geometry (beam width is w).

By equating the risk of ruptures of equations (11) and (62), we obtain

$$\int_V \left(\frac{\sigma_x}{\sigma_{oV}} \right)^{m_V} dV = C_V \sigma_f^{m_V} \quad (74)$$

and, after integrating over the tensile portion of the bar, the scale parameter is

$$\sigma_{oV} = \left[\frac{wh(L_1 + m_V L_2)}{2 C_V (m_V + 1)^2} \right]^{1/m_V} = \left(\frac{V_e}{C_V} \right)^{1/m_V} \quad (75)$$

where V_e is the effective volume. For uniaxial tensile loading, the effective volume is equal to the gage volume V_g , which is the uniformly stressed region where fracture is expected to occur.

For the Batdorf model, using the shear-insensitive case from table II(b), we obtain

$$\frac{\Omega(\Sigma, \sigma_{cr})}{4\pi} = 1 - \sqrt{\frac{\sigma_{cr}}{\sigma_x}} \quad (76)$$

From equations (18b) and (19), after performing the $d\sigma_{cr}$ integration, the risk of rupture for the four-point bend specimen is

$$\begin{aligned} \int_V \left[\int_0^{\sigma_{cr, \max}} \frac{\Omega(\Sigma, \sigma_{cr})}{4\pi} (m_V k_{BV} \sigma_{cr}^{m_V - 1}) d\sigma_{cr} \right] dV \\ = \frac{k_{BV}}{2m_V + 1} \int_V \sigma_x^{m_V} dV \end{aligned} \quad (77)$$

Equating risk of ruptures from equations (77) and (62) gives

$$C_V \sigma_f^{m_V} = \frac{k_{BV}}{2m_V + 1} \int_V \sigma_x^{m_V} dV \quad (78)$$

from which, after integrating the stress over the tensile loaded volume with σ_x defined in equation (73), we get

$$k_{BV} = (2m_V + 1) \left[\frac{2C_V(m_V + 1)^2}{wh(L_1 + m_V L_2)} \right] = (2m_V + 1) \left(\frac{C_V}{V_e} \right) \quad (79)$$

Using equation (75) and the previously defined Weibull crack density coefficient, we obtain

$$C_V = \frac{V_e}{(\sigma_{oV})^{m_V}} = k_{wV} V_e \quad (80)$$

Substituting equation (80) into equation (79) and rearranging gives the normalized Batdorf crack density coefficient for the shear-insensitive case,

$$\bar{k}_{BV} = \frac{k_{BV}}{k_{wV}} = 2m_V + 1 \quad (81)$$

For the Batdorf shear-sensitive case, assuming a Griffith crack and coplanar strain energy release rate criterion, we obtain $\Omega(\Sigma, \sigma_{cr})/4\pi$ from table II(b). For uniaxial loading σ , after performing the indicated integration we get

$$\int_V \left[\int_0^{\sigma} \frac{\Omega(\Sigma, \sigma_{cr})}{4\pi} \frac{dN_V(\sigma_{cr})}{d\sigma_{cr}} d\sigma_{cr} \right] dV = \frac{k_{BV}}{m_V + 1} \int_V \sigma^{m_V} dV \quad (82)$$

Again equating the risk of ruptures from equations (62) and (82) in terms of the effective volume gives

$$C_V \sigma^{m_V} = \frac{k_{BV}}{m_V + 1} \sigma^{m_V} V_e \quad (83)$$

Using equation (80), we substitute for C_V to get

$$k_{wV} = \frac{k_{BV}}{m_V + 1} \quad (84)$$

from which the normalized crack density coefficient for the selected shear-sensitive case is

$$\bar{k}_{BV} = \frac{k_{BV}}{k_{wV}} = m_V + 1 \quad (85)$$

In the CARES program, k_{BV} is computed numerically for a shear-sensitive material for the general case where no closed-

form solution exists. By using equations (18b) and (19) and equating the appropriate risk of ruptures, we obtain

$$C_V \sigma_f^{m_V} = \frac{k_{BV} m_V}{4\pi} \int_V \left[\int_0^{\sigma_{cr}^{\max}} \Omega(\Sigma, \sigma_{cr}) \sigma_{cr}^{m_V-1} d\sigma_{cr} \right] dV \quad (86)$$

or rearranging

$$k_{BV} = \frac{4\pi C_V \sigma_f^{m_V}}{m_V \int_V \left[\int_0^{\sigma_{cr}^{\max}} \Omega(\Sigma, \sigma_{cr}) \sigma_{cr}^{m_V-1} d\sigma_{cr} \right] dV} \quad (87)$$

For surface flaw analysis of four-point MOR bars with known geometry (fig. 14), the value of C_S and m_S in equation (62) is obtained from the least-squares or maximum likelihood analysis. Equating the risk of ruptures of equations (47) and (62) gives

$$\int_A \left(\frac{\sigma_x}{\sigma_{oS}} \right)^{m_S} dA = C_S \sigma_f^{m_S} \quad (88)$$

By using the tensile surface stress on the beam sides as given by equation (73), and in addition at $y = h/2$, where

$$\left. \begin{aligned} \sigma_x &= \frac{2x\sigma_f}{(L_1 - L_2)} & 0 \leq x \leq \frac{L_1 - L_2}{2} \\ \sigma_x &= \sigma_f & \frac{L_1 - L_2}{2} \leq x \leq \frac{L_1 + L_2}{2} \\ \sigma_x &= \frac{2(L_1 - x)}{(L_1 - L_2)} \sigma_f & \frac{L_1 + L_2}{2} \leq x \leq L_1 \end{aligned} \right\} \quad (89)$$

then substituting for σ_x and performing the integration in equation (88), the scale parameter is obtained as

$$\sigma_{oS} = \left\{ \left[\frac{\left(\frac{L_2}{L_1} \right)^{m_S + 1}}{C_S (m_S + 1)^2} \right] \left(\frac{m_S w}{w + h} + 1 \right) (w + h) L_1 \right\}^{1/m_S} \quad (90a)$$

or

$$\sigma_{oS} = \left(\frac{A_e}{C_S} \right)^{1/m_S} \quad (90b)$$

where A_e is the effective area. For uniaxial tensile loading, the effective area is equal to the specimen gage area A_g , which is the total specimen surface area of interest.

For surface flaw reliability analysis with the Weibull normal stress averaging method, we calculate the polyaxial crack density coefficient k_{wps} from the following equation (refs. 30 and 47):

$$k_{wps} = \frac{m_S \sqrt{\pi} \Gamma(m_S) k_{wS}}{\Gamma\left(m_S + \frac{1}{2}\right)} \quad (91)$$

where k_{wS} has been previously defined in equation (47).

By combining equations (51) and (52) for the Batdorf surface flaw model, we can express P_{fS} as

$$P_{fS} = 1 - \exp \left\{ -m_S k_{BS} \int_A \left[\int_0^{\sigma_{cr}^{\max}} \frac{\omega(\Sigma, \sigma_{cr})}{2\pi} \sigma_{cr}^{m_S-1} d\sigma_{cr} \right] dA \right\} \quad (92)$$

For uniaxial tension with a shear-insensitive fracture criterion, substituting for $\omega(\Sigma, \sigma_{cr})/2\pi$ from table III ($\sigma_2 = 0$), we obtain

$$P_{fS} = 1 - \exp \left\{ -\frac{2m_S k_{BS}}{\pi} \int_A \left[\int_0^{\sigma_1} \cos^{-1} \sqrt{\frac{\sigma_{cr}}{\sigma_1}} \sigma_{cr}^{m_S-1} d\sigma_{cr} \right] dA \right\} \quad (93)$$

Equating the risk of rupture in equation (93) with that of equation (47) results in

$$\bar{k}_{BS} = \frac{k_{BS}}{k_{wS}} = \frac{m_S \sqrt{\pi} \Gamma(m_S)}{\Gamma\left(m_S + \frac{1}{2}\right)} \quad (94)$$

Hence, for this special case the Batdorf crack density coefficient is identical to the Weibull polyaxial crack density coefficient: that is,

$$k_{BS} = k_{wps} \quad (95)$$

Similar results were obtained for volume-flaw-based analysis as well.

For the general shear-sensitive case, k_{BS} is computed numerically since no closed-form solution exists. Thus, equating the risk of ruptures of equations (62) and (92) gives

$$C_S \sigma_f^{m_S} = m_S k_{BS} \int_A \left[\int_0^{\sigma_{cr, \max}} \frac{\omega(\Sigma, \sigma_{cr})}{2\pi} \sigma_{cr}^{m_S - 1} d\sigma_{cr} \right] dA \quad (96)$$

from which we obtain

$$k_{BS} = \frac{2\pi C_S \sigma_f^{m_S}}{m_S \int_A \left[\int_0^{\sigma_{cr, \max}} \omega(\Sigma, \sigma_{cr}) \sigma_{cr}^{m_S - 1} d\sigma_{cr} \right] dA} \quad (97)$$

Example Problems

Example 1—Transversely Loaded Circular Disk

Rufin, Samos, and Bollard (refs. 41, 53, and 54) conducted experimental tests and theoretical studies on ceramic materials at the University of Washington. They used alumina data to evaluate the accuracy of various fast-fracture failure models for brittle materials. Four-point MOR bar specimens were used to estimate the statistical material strength parameters m_V and C_V associated with volume flaw analysis. Then the Weibull PIA and Batdorf volume flaw fracture models, along with axisymmetric finite element analysis, were used to predict the response of a transversely pressure loaded and simply supported circular disk. The data published in reference 41 were used to help validate the CARES code for volume flaw analysis, and the results obtained from CARES2 were compared with those obtained by Rufin (ref. 41) and subsequently by Emery (A.F. Emery, Nov. 1984, University of Washington, Seattle, WA, personal communication). For illustrative purposes only, the same test data were used with the CARES code in another set of calculations that assumed that randomly oriented surface flaws were the dominant failure-causing mechanism.

The material parameters were determined from 15 small-beam specimens that were cut from the alumina disks. The average beam width and depth were 3.73 mm (0.147 in.) and 1.80 mm (0.071 in.), respectively. The distance between the outer loads was 25.40 mm (1.0 in.), and the inner loads were 12.70 mm (0.50 in.) apart. The specimen edges were polished to eliminate potential edge effects. The extreme fiber stresses at fracture and the corresponding failure probabilities, determined from the ranking equation $P_f = (i/(N + 1))$, are summarized in table IV (A.C. Rufin, 1983, Boeing Co., Seattle, Washington, personal communication).

A CARES input file is reproduced at the end of this example. The MOR bar fracture data were input as a complete sample (no competing failure modes), and the least-squares analysis option was chosen with a slight modification to subroutine LEAST2 so that the ranking equation listed in table IV was used. The corresponding CARES2 output file is also reproduced at the end of this example. From the outlier test,

TABLE IV.—FRACTURE STRESSES AND FAILURE PROBABILITIES FOR ALUMINA FOUR-POINT BEND MODULUS-OF-RUPTURE SPECIMENS

Rank, <i>i</i>	Fracture stress		Failure probability ^a , <i>i</i> /(<i>N</i> +1)
	MPa	psi	
1	315.45	45 750	0.063
2	317.87	46 100	.125
3	331.66	48 100	.188
4	331.83	48 125	.250
5	338.72	49 125	.312
6	339.16	49 188	.375
7	341.31	49 500	.438
8	342.17	49 625	.500
9	342.43	49 650	.563
10	343.03	49 750	.625
11	343.72	49 850	.688
12	344.00	49 890	.750
13	349.07	50 625	.813
14	355.96	51 625	.875
15	360.27	52 250	.938

^aRanking equation used in SCARE.

the lowest strength value, 315.45 MPa (45 750 psi), was detected as being deviant at the 5-percent significance level. Since the significance level was above 1 percent, this fracture stress was included in the subsequent analysis.

The value of \hat{m}_V obtained by CARES from least-squares analysis for the alumina bend bar data is 28.53, which compares favorably with Rufin's calculated $\hat{m}_V = 28.40$. The small difference between \hat{m}_V values is probably due to round-off error. When the median rank formula $(i - 0.3)/(N + 0.4)$ (ref. 52) is used with the least-squares analysis, the value of m_V is estimated to be 31.14. The maximum likelihood method predicts $m_V = 33.58$. The large values of \hat{m}_V reflect the small amount of scatter of fracture strengths observed in the data. There is an uncertainty as to the true value of m_V because of the small number of test specimens. For a sample size of 15, the 90-percent confidence bounds for $m_V = 33.58$ are 21.47 and 43.61. Typical monolithic ceramics have m_V values ranging from below 10 to the low 30's. The value of 28.53 for m_V will be used throughout this example. For the test data, the significance levels for the Kolmogorov-Smirnov and Anderson-Darling goodness-of-fit tests are 42.1 and 67.7 percent, respectively. Interpretation of these values is subjective and is included for comparison purposes only. In addition, the fracture data lie within the calculated Kanofsky-Srinivasan 90-percent confidence band values. All of these results indicate that the fracture data fit a Weibull distribution.

After values of m_V and C_V were estimated, equation (75) was used by CARES to obtain $\sigma_{oV} = 169.70$ MPa (m)^{3/28.53} (36 200 psi (in.)^{0.105}), which compares well with the value of 166 MPa (m)^{3/28.40} (35 540 psi (in.)^{0.106}) from reference 41. Reasons for the difference are that slightly different values

of m_V were used and Rufin assumed that the fracture of the specimen was restricted to the inner span of the beam, whereas equation (75), considers failure along the whole span.

Given the Weibull modulus, the shear-insensitive normalized Batdorf crack density coefficient \bar{k}_{BV} was calculated from equation (81), which yielded a value of 58.06. Rufin (ref. 41) lists an erroneous value for \bar{k}_{BV} , which should always be equal to $(2m_V + 1)$ in any system of measurement and is just the nondimensionalized form of k_{BV} . The k_{BV} used for most of this example was calculated by assuming shear-insensitivity in uniaxial loading (IKBAT = 0 input option).

Assuming that the data in table IV are also applicable to surface flaw reliability, we have $m_S = m_V = 28.53$, and from equation (90a), $\sigma_{0S} = 244.3 \text{ MPa (m)}^{2/28.53} (45\,840 \text{ psi (in.)}^{2/28.53})$. In addition, from the numerical solution of equation (94), the shear-insensitive normalized Batdorf surface crack density coefficient \bar{k}_{BS} is 9.557.

Rufin and Samos obtained experimental results from pressure-loaded circular disks, and both CARES volume and surface flaw fracture models were used to predict the response based on the statistical parameters determined from the MOR specimens. The average disk dimensions were 51.6 mm (2.03 in.) outside diameter and 1.80 mm (0.071 in.) thickness. The support radius and the radius of the pressurized area of the disks were both 23.4 mm (0.92 in.).

MSC/NASTRAN Rigid Format 47 (cyclic symmetry) was used to calculate the disk stresses under various pressures at

room temperature. A total of 40 three-dimensional elements were used; 4 elements were PENTA's, and the other 36 elements were HEXA's. The model geometry was a 7.5° sector, and thus, 48 segments were required to make up the total disk (fig. 15). One layer of 10 elements was used for the compressive domain of the disk, and three layers of 10 elements each modeled the tensile portion. In the tensile domain, variable mesh size was selected with thinner elements near regions of maximum stress. In the tensile half of the disk, the thickness of the layer of elements at the disk surface was 0.051 mm (0.002 in.) followed by layers with thicknesses of 0.203 mm (0.008 in.) and 0.648 mm (0.0255 in.). Volume-flaw-based reliability analysis requires output from three-dimensional elements (except when axisymmetric elements are used). Surface-flaw-based reliability analysis was obtained from the output of two-dimensional shell elements. One TRIA6 and nine QUAD8 shell elements were used to model the tensile surface of the disk. The shell elements shared common nodes with the solid elements. Two-dimensional elements are used by the CARES code only to identify external surfaces and obtain corresponding in-plane stresses and areas. The contribution of these elements to the overall stiffness of the model is negligible. The thickness of the shell elements was $2.54 \times 10^{-5} \text{ mm (} 1.0 \times 10^{-6} \text{ in.)}$, and only membrane properties were assigned to these elements via the PSHELL BULK DATA card. Material properties of the shell elements were consistent with the material properties of the solid elements.

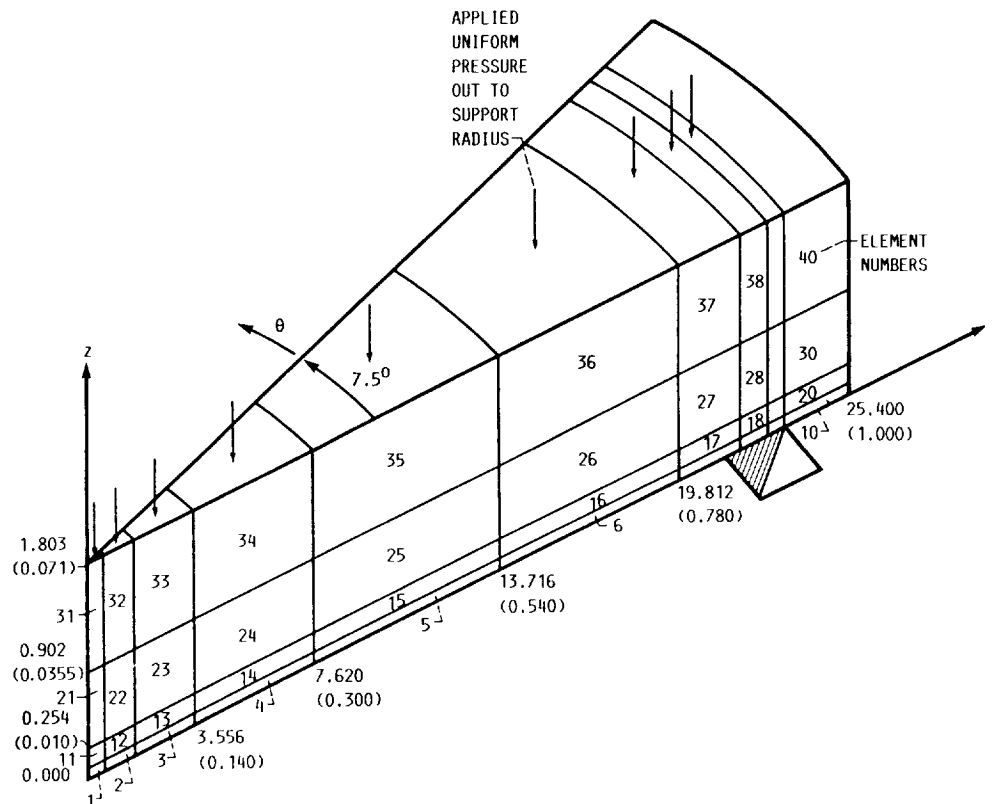

Figure 15.—Finite element mesh of disk segment. All dimensions are in millimeters (inches), unless marked otherwise.

The extreme-layer radial and tangential stresses from the NASTRAN analysis were approximately within 0.75 percent of those calculated at the extreme fiber from closed-form solutions. This accuracy check was made by slightly altering the boundary conditions and applying the pressure over the entire surface to match analytically solved configurations.

The total disk volume and area were independently calculated and compared with that obtained from NASTRAN, which uses shape functions. The NASTRAN model volume and surface area were within 0.3 percent of the calculated values. Fifteen Gauss integration points (NGP = 15) were used for the reliability analysis with CARES. The English system of units was used for all analyses. The values of Young's modulus and Poisson's ratio for alumina at room temperature were taken as 405 GPa (5.87×10^7 psi) and 0.25, respectively. To cover the entire failure probability range for the different fracture models, the disk loading was varied between 1.24 and 1.79 MPa (180 to 260 psi). A typical MSC/NASTRAN input file, including the MSC/NASTRAN EXECUTIVE and CASE CONTROL DECKs and the appropriate BULK DATA DECK for a selected pressure of 1.45 MPa (210 psi), is shown at the end of this example. MSGMESH was not used to prepare this simple input.

After completing the structural analysis and creating the NASTRAN punch file, printout file, and an optional plot file, the CARES input data were prepared as shown at the end of this example. This data set was created in accordance with the requirements set forth in the **Master Control Input and Material Control Input** sections. Also reproduced is the corresponding CARES2 output with the subelement stresses shown. The material volume flaws in this input were modeled as penny-shaped cracks, and the material surface flaws were modeled as semicircular cracks. The semi-empirical equation (26) developed by Shetty (ref. 26) was used with a shear-sensitivity constant of $\bar{C} = 0.80$. Similar reliability analyses were made for the Weibull PIA model and for the shear-insensitive and shear-sensitive Batdorf models using various fracture criteria and flaw geometries. This computer output is not reproduced in this manual, but the reliability results are shown in tables V and VI, and also in figures 16 and 17.

The answers predicted by the CARES PIA model did not agree with Rufin's results for volume flaw analysis (ref. 41). Hence, independent manual calculations were made to evaluate the CARES program predictions. To minimize the calculations, only the CARES1 version was checked. Under a pressure of 1.65 MPa (240 psi), a P_{fV} of 0.403 was obtained from manual calculations compared with 0.405 from CARES1. For the same loading and support conditions, the CARES2 code calculated a P_{fV} of 0.493. These results are dependent on the selected material parameters as well as on the finite element mesh. Emery (A.F. Emery, Nov. 1984, University of Washington, Seattle, WA, personal communication) selectively checked some of the CARES2 PIA predictions by using a revised University of Washington reliability code, and obtained excellent agreement with the CARES2 answers.

The CARES2 program usually gives higher failure probabilities than the CARES1 version for the same problem. In addition, the material parameters used by Rufin ($m_V = 28.4$ and $\sigma_{oV} = 166$ MPa (m)^{3/28.4}) give higher failure rates than those obtained in CARES ($m_V = 28.53$ and $\sigma_{oV} = 169.7$ MPa (m)^{3/28.53}), with everything else equal for a given case. The thickness of the extreme two layers of finite elements in the tensile part of the disk was varied to evaluate mesh effects on the calculated reliability results. The use of a coarser mesh near the extreme fibers (thickness = 0.203 mm (0.008 in.)) significantly lowered the predicted failure probabilities.

Batdorf (ref. 46) derived a simple relationship between the failure probabilities obtained for the shear-insensitive Batdorf and Weibull PIA models when equibiaxial stress states and low failure probabilities are expected. Under these conditions,

$$\{P_{fV}\}_{\sigma_n} = m_V^{0.45} \{P_{fV}\}_{PIA} \quad (98)$$

where subscripts σ_n denote the failure probability predicted from the shear-insensitive model and PIA denotes the failure probability predicted for the PIA model, respectively. For a transversely loaded disk, the highest stressed region is in an equibiaxial stress state located at the disk center. Under a pressure of 1.38 MPa (200 psi), low values of P_{fV} are obtained. Using the CARES2 version of the program, we calculated a P_{fV} of 0.0167 for the shear-insensitive model. Similarly, using the PIA model, we calculated a P_{fV} of 0.0037. From equation (98)

$$\{P_{fV}\}_{PIA} = \frac{0.0167}{(28.53)^{0.45}} = 0.0037 \quad (99)$$

which shows that the Batdorf prediction and CARES2 results are in good agreement.

Reliability calculations were performed for various pressures and with different fracture models by both versions of the CARES code. Results are given in tables V and VI. Figures 16 and 17 are plots of CARES2 results and Rufin's experimental data. Differences in material properties, finite element mesh sizes, and finite elements could possibly account for some differences in answers from those given in reference 41. However, the shear-sensitive and PIA results of reference 41 could not be adequately duplicated.

Results were obtained by applying equations (20), (21), (24), (25), (27), and (28) for the volume flaw model. For surface reliability results, equations (53) to (56) were used. Both volume and surface flaw analysis used the shear-insensitive Batdorf crack density coefficient (IKBAT = 0). In addition, results are given in the last column of tables V and VI for an approximation of the maximum strain energy release rate criterion G_{max} , with a Griffith crack. In this case Shetty's criterion is used with $\bar{C} = 0.82$, and IKBAT = 1. Failure probabilities calculated from decreasingly shear-sensitive effective stress equations move the Weibull sigmoidal distri-

TABLE V.—FAILURE PROBABILITIES OF A TRANSVERSELY LOADED CIRCULAR DISK—VOLUME FLAW ANALYSIS

[NGP = 15; $m_V = 28.53$; $\sigma_{iV} = 169.7 \text{ MPa(m)}^{3/28.53}$ (36 200 psi(in.)^{3/28.53}.)]

Pressure		Failure probability								
		IKBAT = 0; $\bar{k}_{BV} = 58.06$							IKBAT = 1; $\bar{k}_{BV} = 2.680$	
MPa	psi	Shetty criterion ($\bar{C} = 0.80$)		Energy release rate criterion, G_T		Maximum tensile stress criterion		Normal stress criterion	PIA criterion	Shetty criterion ($\bar{C} = 0.82$); Griffith crack (G_{max} approx.)
		Griffith crack	Penny-shaped crack	Griffith crack	Penny-shaped crack	Griffith crack	Penny-shaped crack			
CARES2 results										
1.241	180	0.0065	0.0240	0.0012	0.0014	0.0010	0.0010	0.0008	0.0002	0.0003
1.310	190	.0301	.1074	.0055	.0064	.0045	.0048	.0039	.0009	.0012
1.379	200	.1238	.3881	.0234	.0273	.0193	.0207	.0167	.0037	.0051
1.448	210	.4123	.8613	.0910	.1053	.0755	.0805	.0656	.0149	.0205
1.517	220	.8652	.9994	.3021	.3427	.2561	.2713	.2258	.0552	.0751
1.586	230	.9992	1.0000	.7216	.7749	.6507	.6754	.5973	.1826	.2423
1.655	240	1.0000	1.0000	.9865	.9934	.9711	.9774	.9533	.4929	.6071
1.724	250	1.0000	1.0000	1.0000	1.0000	1.0000	1.0000	.9999	.8865	.9499
1.793	260	1.0000	1.0000	1.0000	1.0000	1.0000	1.0000	1.0000	.9987	.9999
CARES1 results										
1.448	210	0.3314	0.7729	0.0699	0.0810	0.0578	0.0618	0.0502	0.0114	0.0156
*1.448	*210	.4080	.8540	.0908	.1049	.0753	.0804	.0655	.0148	.0203

*For axisymmetric elements.

TABLE VI.—FAILURE PROBABILITIES OF A TRANSVERSELY LOADED CIRCULAR DISK—SURFACE FLAW ANALYSIS

[NGP = 15; $m_S = 28.53$; $\sigma_{iS} = 244.3 \text{ MPa(m)}^{2/28.53}$ (45 840 psi(in.)^{2/28.53}.)]

Pressure		Failure probability								
		IKBAT = 0; $\bar{k}_{BS} = 9.557$							IKBAT = 1; $\bar{k}_{BS} = 1.339$	
MPa	psi	Shetty criterion ($\bar{C} = 0.80$)			Energy release rate criterion, G_T		Normal stress criterion	PIA criterion	Shetty criterion ($\bar{C} = 0.82$); Griffith crack (G_{max} approx.)	
		Griffith crack	Griffith notch	Semi-circular crack	Griffith crack	Griffith notch				
CARES2 results										
1.241	180	0.0009	0.0009	0.0009	0.0009	0.0009	0.0009	0.0002	0.0001	
1.310	190	.0044	.0044	.0044	.0044	.0044	.0044	.0010	.0006	
1.379	200	.0188	.0188	.0188	.0188	.0188	.0187	.0041	.0027	
1.448	210	.0734	.0734	.0734	.0734	.0734	.0733	.0165	.0106	
1.517	220	.2500	.2498	.2499	.2499	.2499	.2495	.0608	.0395	
1.586	230	.6402	.6399	.6401	.6401	.6402	.6395	.1999	.1335	
1.655	240	.9680	.9679	.9680	.9680	.9680	.9678	.5281	.3827	
1.724	250	1.0000	1.0000	1.0000	1.0000	1.0000	1.0000	.9099	.7869	
1.793	260	1.0000	1.0000	1.0000	1.0000	1.0000	1.0000	.9994	.9912	
CARES1 results										
1.448	210	0.0665	0.0664	0.0664	0.0666	0.0666	0.0665	0.0143	0.0096	

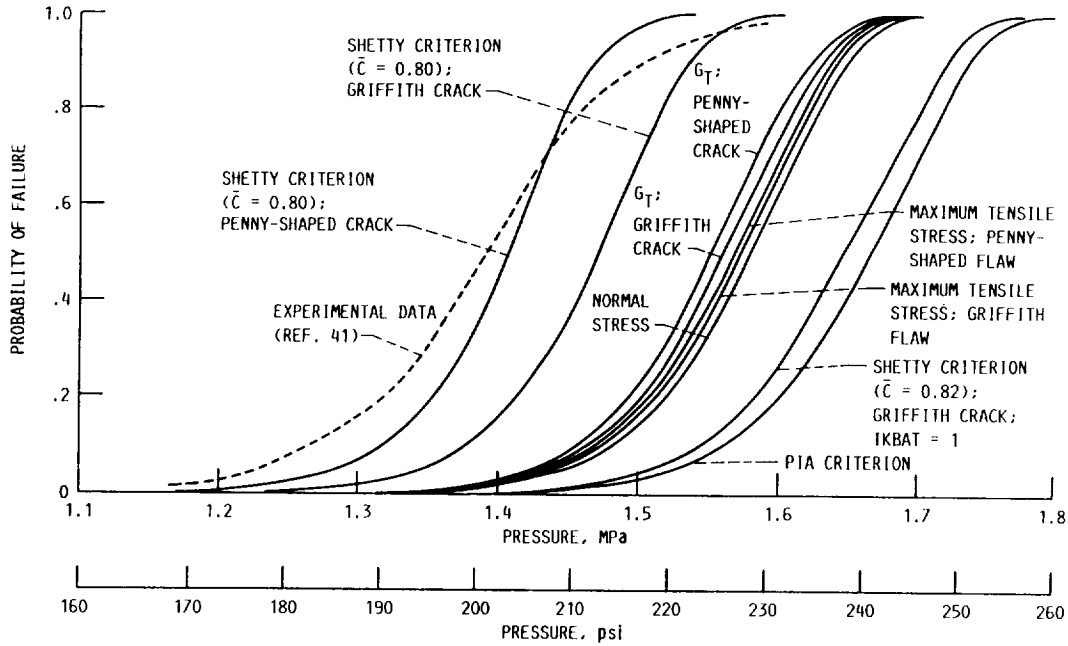

Figure 16.—Comparison of experimental failure probabilities with those for various fracture models for a transversely loaded circular disk (volume flaw analysis). $NGP = 15$; $m_V = 28.53$; $\sigma_{oV} = 169.7 \text{ MPa(m)}^{3/28.53}$ ($36\ 200 \text{ psi(in.)}^{3/28.53}$). For $IKBAT = 0$, $\bar{k}_{BV} = 58.06$; for $IKBAT = 1$, $\bar{k}_{BV} = 2.68$ (only for Griffith crack, Shetty criterion, $\bar{C} = 0.82$).

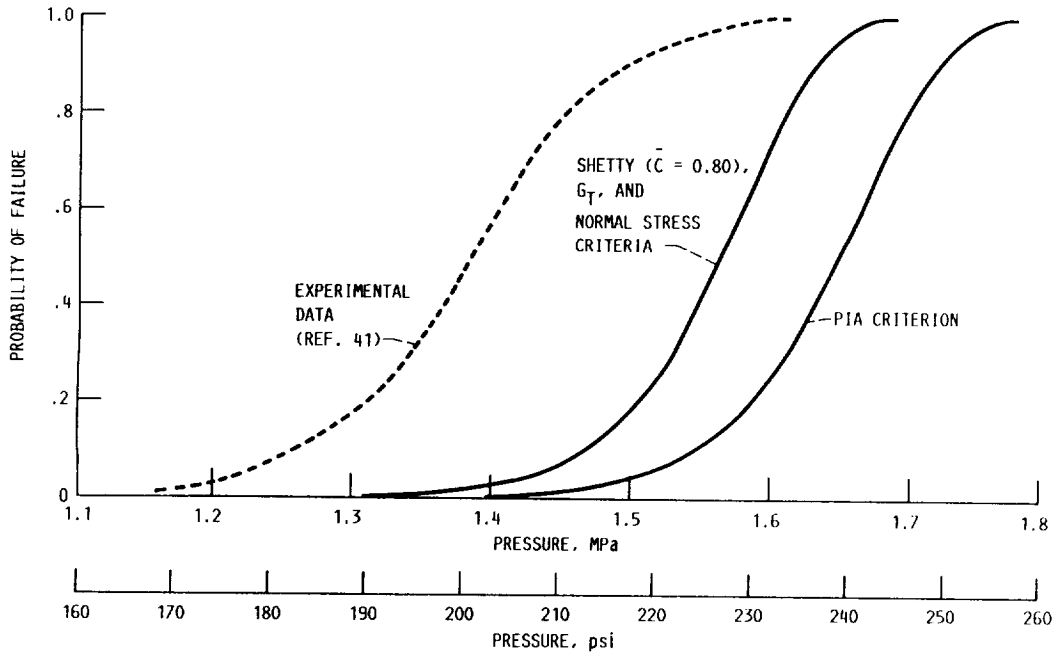

Figure 17.—Comparison of experimental failure probabilities with those for Shetty ($\bar{C} = 0.80$), total strain energy release rate G_T , normal stress, and PIA fracture criteria for a transversely loaded circular disk (surface flaw analysis). $NGP = 15$; $m_S = 28.53$; $\sigma_{oS} = 244.3 \text{ MPa(m)}^{2/28.53}$ ($45\ 840 \text{ psi(in.)}^{2/28.53}$); for $IKBAT = 0$, $\bar{k}_{BS} = 9.557$.

bution curve towards the fully shear-insensitive case as shown in figure 16. For this material, the Shetty criterion with $\bar{C} = 0.80$, $\text{IKBAT} = 0$, and the penny-shaped crack gives the best agreement with experimental data. Results get progressively closer to the experimental data in the order PIA, normal stress, maximum tensile stress, energy release rate G_T , and Shetty's criterion for $\text{IKBAT} = 0$. Contrary to this trend, the results for $\text{IKBAT} = 1$ (fig. 16) show that increasing shear sensitivity moves the Weibull sigmoidal distribution curve towards the PIA results and gives progressively less conservative predictions.

Surface-flaw-based reliability results are shown in figure 17. For this problem, when the $\text{IKBAT} = 0$ option for material characterization was used, the reliability predictions from the shear-sensitive criteria showed little difference from the shear-insensitive models for all crack shapes. This is due to the predominance of equibiaxial stresses on the disk surface; hence, in this case the shear stress on individual crack planes is mostly negligible. However, using $\text{IKBAT} = 1$, a Griffith crack, and Shetty's criterion with $\bar{C} = 0.82$, to approximate the G_{max} criterion, gives the results shown in table VI. These results indicate that increased shear sensitivity gives a less conservative failure prediction. This trend again is contrary to the results obtained by using $\text{IKBAT} = 0$.

There was no fractography performed on the disks or on the MOR bar specimens. However, the volume flaw analysis fits the experimental data (fig. 16) much better than the surface

flaw analysis (fig. 17). Therefore, the experimental specimens most likely fractured because of volume flaws. Note that the experimental results for the disks show greater data scatter (smaller slope) than was predicted from the four-point bend specimen data, but the difference is not statistically significant because of the small amount of specimens broken for each test. Experimental validation will guide the proper choice among the available CARES fracture models for a given type of brittle material.

It is less demanding on computer systems to work with axisymmetric elements when the geometry and loading permit their use. However, for adequate accuracy a much finer mesh is usually required, especially when the application involves bending loads. TRIAX6 axisymmetric elements can be used by the CARES code for volume flaw reliability studies. Because of a volume calculation error in MSC/NASTRAN version 65 that results when the TRIAX6 element is used, an extra subroutine was written to determine the element volumes from the nodal data. This subroutine is not included in the standard CARES programs since future versions of MSC/NASTRAN should be error free. Results for example 1 obtained with TRIAX6 elements are shown in table V for 1.45 MPa (210 psi). The results are in good agreement with the predictions from CARES2 for the same pressure. The MSC/NASTRAN input file with the TRIAX6 element is reproduced at the end of this example.

NASTRAN INPUT FILE—SOLID AND SHELL ELEMENTS

```

# USER=_____ PW=_____
# QSUB -r   example1           # JOB NAME
# QSUB -eo                                     # combine stderr and stdout
# QSUB -lM 1.0mw                # set memory limit
# QSUB -lt 00:01:00            # set cpu time limit
set -vkkx
cd
cat >exlnastin<<"EOF"
NASTRAN DAYLIMIT = -1
ID CERAMIC,FRACTURE
APP DISP
SOL 47
TIME 30
CEND
TITLE = TRANSVERSELY LOADED CIRCULAR DISK
SUBTITLE = SOLID ELEMENTS WITH CYCLIC SYMMETRY MODELING
SET 2 = 0
HARMONICS =2
SPC=1
LOAD=10
SET 5= 1
NOUTPUT=5
DISP=ALL
STRESS(PRINT,PUNCH)=ALL
ECHO=PUNCH
OUTPUT(PLOT)
PLOTTER NAST
SET 1 = HEXA,PENTA
SET 2 INCLUDE 1, 2, 3, 4, 5, 6, 7, 8, 9, 10
SET 3 INCLUDE 11, 12, 13, 14, 15, 16, 17, 18, 19, 20
SET 4 INCLUDE 21, 22, 23, 24, 25, 26, 27, 28, 29, 30
SET 5 INCLUDE 31, 32, 33, 34, 35, 36, 37, 38, 39, 40
SET 6 = QUAD8,TRIA6
AXES MX,MY,MZ
PTITLE = TRANSVERSELY LOADED CIRCULAR DISK
FIND SCALE, ORIGIN 1, SET 1
PLOT SET 1 ORIGIN 1, LABEL ELEMENTS SHAPE
PLOT SET 1 ORIGIN 1, LABEL GRID SHAPE
FIND SCALE, ORIGIN 2, SET 2
PLOT SET 2 ORIGIN 2, LABEL ELEMENTS SHAPE
PLOT SET 2 ORIGIN 2, LABEL GRID SHAPE
FIND SCALE, ORIGIN 3, SET 3
PLOT SET 3 ORIGIN 3, LABEL ELEMENTS SHAPE
PLOT SET 3 ORIGIN 3, LABEL GRID SHAPE
FIND SCALE, ORIGIN 4, SET 4
PLOT SET 4 ORIGIN 4, LABEL ELEMENTS SHAPE
PLOT SET 4 ORIGIN 4, LABEL GRID SHAPE
FIND SCALE, ORIGIN 5, SET 5
PLOT SET 5 ORIGIN 5, LABEL ELEMENTS SHAPE
PLOT SET 5 ORIGIN 5, LABEL GRID SHAPE
FIND SCALE, ORIGIN 6, SET 6
PLOT SET 6 ORIGIN 6, LABEL ELEMENTS SHAPE
PLOT SET 6 ORIGIN 6, LABEL GRID SHAPE
PLOT STATIC DEFORMATION,SET 1 ORIGIN 1
BEGIN BULK

```

	2	3	4	5	6	7	8	9	10
\$									
\$									
\$									
CTRIA6	41,101,1,3,33,2,22,32								
CQUAD8	42,101,3,5,35,33,4,23,CQ1								
+Q1	34,22								
CQUAD8	43,101,5,7,37,35,6,24,CQ2								
+Q2	36,23								
CQUAD8	44,101,7,9,39,37,8,25,CQ3								
+Q3	38,24								
CQUAD8	45,101,9,11,41,39,10,26,CQ4								
+Q4	40,25								
CQUAD8	6,101,11,13,43,41,12,27,CQ5								
+Q5	42,26								
CQUAD8	7,101,13,15,45,43,14,28,CQ6								
+Q6	44,27								
CQUAD8	8,101,15,17,47,45,16,29,CQ7								
+Q7	46,28								
CQUAD8	49,101,17,19,49,47,18,30,CQ8								
+Q8	48,29								
CQUAD8	50,101,19,21,51,49,20,31,CQ9								
+Q9	50,30								
PSHELL	101,300,.000001								
CPENTA	1	100	1	3	33	73	75	105	PE1
+E1	2	22	32	52	53	63	74	94	PE1A
+E1A	104								
CHEXA	2	100	3	5	35	33	75	77	HE2
+E2	107	105	4	23	34	22	53	54	HE2A
+E2A	64	63	76	95	106	94			
CHEXA	3	100	5	7	37	35	77	79	HE3
+E3	109	107	6	24	36	23	54	55	HE3A
+E3A	65	64	78	96	108	95			
CHEXA	4	100	7	9	39	37	79	81	HE4
+E4	111	109	8	25	38	24	55	56	HE4A
+E4A	66	65	80	97	110	96			
CHEXA	5	100	9	11	41	39	81	83	HE5
+E5	113	111	10	26	40	25	56	57	HE51
+E51	67	66	82	98	112	97			
CHEXA	6	100	11	13	43	41	83	85	HE6
+E6	115	113	12	27	42	26	57	58	HE61
+E61	68	67	84	99	114	98			
CHEXA	7	100	13	15	45	43	85	87	HE7
+E7	117	115	14	28	44	27	58	59	HE71
+E71	69	68	86	100	116	99			
CHEXA	8	100	15	17	47	45	87	89	HE8
+E8	119	117	16	29	46	28	59	60	HE81
+E81	70	69	88	101	118	100			
CHEXA	9	100	17	19	49	47	89	91	HE9
+E9	121	119	18	30	48	29	60	61	HE91
+E91	71	70	90	102	120	101			
CHEXA	10	100	19	21	51	49	91	93	HE10
+E10	123	121	20	31	50	30	61	62	HE101
+E101	72	71	92	103	122	102			
CPENTA	11	100	73	75	105	145	147	177	PE11
+E11	74	94	104	124	125	135	146	166	PE111

+E111	176								
CHEXA	12	100	75	77	107	105	147	149	HE12
+E12	179	177	76	95	106	94	125	126	HE121
+E121	136	135	148	167	178	166			
CHEXA	13	100	77	79	109	107	149	151	HE13
+E13	181	179	78	96	108	95	126	127	HE131
+E131	137	136	150	168	180	167			
CHEXA	14	100	79	81	111	109	151	153	HE14
+E14	183	181	80	97	110	96	127	128	HE141
+E141	138	137	152	169	182	168			
CHEXA	15	100	81	83	113	111	153	155	HE15
+E15	185	183	82	98	112	97	128	129	HE151
+E151	139	138	154	170	184	169			
CHEXA	16	100	83	85	115	113	155	157	HE16
+E16	187	185	84	99	114	98	129	130	HE161
+E161	140	139	156	171	186	170			
CHEXA	17	100	85	87	117	115	157	159	HE17
+E17	189	187	86	100	116	99	130	131	HE171
+E171	141	140	158	172	188	171			
CHEXA	18	100	87	89	119	117	159	161	HE18
+E18	191	189	88	101	118	100	131	132	HE181
+E181	142	141	160	173	190	172			
CHEXA	19	100	89	91	121	119	161	163	HE19
+E19	193	191	90	102	120	101	132	133	HE191
+E191	143	142	162	174	192	173			
CHEXA	20	100	91	93	123	121	163	165	HE20
+E20	195	193	92	103	122	102	133	134	HE201
+E201	144	143	164	175	194	174			
CPENTA	21	100	145	147	177	217	219	249	PE21
+E21	146	166	176	196	197	207	218	238	PE211
+E211	248								
CHEXA	22	100	147	149	179	177	219	221	EE22
+E22	251	249	148	167	178	166	197	198	EE221
+E221	208	207	220	239	250	238			
CHEXA	23	100	149	151	181	179	221	223	EE23
+E23	253	251	150	168	180	167	198	199	EE231
+E231	209	208	222	240	252	239			
CHEXA	24	100	151	153	183	181	223	225	EE24
+E24	255	253	152	169	182	168	199	200	EE241
+E241	210	209	224	241	254	240			
CHEXA	25	100	153	155	185	183	225	227	EE25
+E25	257	255	154	170	184	169	200	201	EE251
+E251	211	210	226	242	256	241			
CHEXA	26	100	155	157	187	185	227	229	EE26
+E26	259	257	156	171	186	170	201	202	EE261
+E261	212	211	228	243	258	242			
CHEXA	27	100	157	159	189	187	229	231	EE27
+E27	261	259	158	172	188	171	202	203	EE271
+E271	213	212	230	244	260	243			
CHEXA	28	100	159	161	191	189	231	233	EE28
+E28	263	261	160	173	190	172	203	204	EE281
+E281	214	213	232	245	262	244			
CHEXA	29	100	161	163	193	191	233	235	EE29
+E29	265	263	162	174	192	173	204	205	EE291
+E291	215	214	234	246	264	245			

CHEXA	30	100	163	165	195	193	235	237	EE30
+E30	267	265	164	175	194	174	205	206	EE301
+E301	216	215	236	247	266	246			
CPENTA	31	100	217	219	249	289	291	321	EE31
+E31	218	238	248	268	269	279	290	310	EE311
+E311	320								
CHEXA	32	100	219	221	251	249	291	293	EE32
+E32	323	321	220	239	250	238	269	270	EE321
+E321	280	279	292	311	322	310			
CHEXA	33	100	221	223	253	251	293	295	EE33
+E33	325	323	222	240	252	239	270	271	EE331
+E331	281	280	294	312	324	311			
CHEXA	34	100	223	225	255	253	295	297	EE34
+E34	327	325	224	241	254	240	271	272	EE341
+E341	282	281	296	313	326	312			
CHEXA	35	100	225	227	257	255	297	299	EE35
+E35	329	327	226	242	256	241	272	273	EE351
+E351	283	282	298	314	328	313			
CHEXA	36	100	227	229	259	257	299	301	EE36
+E36	331	329	228	243	258	242	273	274	EE361
+E361	284	283	300	315	330	314			
CHEXA	37	100	229	231	261	259	301	303	EE37
+E37	333	331	230	244	260	243	274	275	EE371
+E371	285	284	302	316	332	315			
CHEXA	38	100	231	233	263	261	303	305	EE38
+E38	335	333	232	245	262	244	275	276	EE381
+E381	286	285	304	317	334	316			
CHEXA	39	100	233	235	265	263	305	307	EE39
+E39	337	335	234	246	264	245	276	277	EE391
+E391	287	286	306	318	336	317			
CHEXA	40	100	235	237	267	265	307	309	EE40
+E40	339	337	236	247	266	246	277	278	EE401
+E401	288	287	308	319	338	318			
CORD2C	5	0	0.	0.	0.	0.	0.	1.	+C
+C	1.	0.0	0.						
CYJOIN	1		2	THRU	21	53	THRU	62	+BC
+BC	74	THRU	93	125	THRU	134	146	147	+BC1
+BC1	148	THRU	165	197	THRU	206	218	219	+BC2
+BC2	220	THRU	237	269	THRU	278	290	291	+BC3
+BC3	292	THRU	309						
CYJOIN	2		32	THRU	51	63	THRU	72	+EF
+EF	104	THRU	123	135	THRU	144	176	177	+EF1
+EF1	178	THRU	195	207	THRU	216	248	249	+EF2
+EF2	250	THRU	267	279	THRU	288	320	321	+EF3
+EF3	322	THRU	339						
CYSYM	48	ROT							
GRDSET		5				5	456		
GRID	1		0.	0.	0.				
GRID	2		0.01	0.	0.				
GRID	3		0.02	0.	0.				
GRID	4		0.04	0.	0.				
GRID	5		0.06	0.	0.				
GRID	6		0.1	0.	0.				
GRID	7		0.14	0.	0.				
GRID	8		0.22	0.	0.				

GRID	9	0.30	0.	0.
GRID	10	0.42	0.	0.
GRID	11	0.54	0.	0.
GRID	12	0.66	0.	0.
GRID	13	0.78	0.	0.
GRID	14	0.82	0.	0.
GRID	15	0.86	0.	0.
GRID	16	0.88	0.	0.
GRID	17	0.90	0.	0.
GRID	18	0.91	0.	0.
GRID	19	0.92	0.	0.
GRID	20	0.96	0.	0.
GRID	21	1.0	0.	0.
GRID	22	0.02	3.75	0.
GRID	23	0.06	3.75	0.
GRID	24	0.14	3.75	0.
GRID	25	0.3	3.75	0.
GRID	26	0.54	3.75	0.
GRID	27	0.78	3.75	0.
GRID	28	0.86	3.75	0.
GRID	29	0.90	3.75	0.
GRID	30	0.92	3.75	0.
GRID	31	1.0	3.75	0.
GRID	32	0.01	7.5	0.
GRID	33	0.02	7.5	0.
GRID	34	0.04	7.5	0.
GRID	35	0.06	7.5	0.
GRID	36	0.1	7.5	0.
GRID	37	0.14	7.5	0.
GRID	38	0.22	7.5	0.
GRID	39	0.30	7.5	0.
GRID	40	0.42	7.5	0.
GRID	41	0.54	7.5	0.
GRID	42	0.66	7.5	0.
GRID	43	0.78	7.5	0.
GRID	44	0.82	7.5	0.
GRID	45	0.86	7.5	0.
GRID	46	0.88	7.5	0.
GRID	47	0.90	7.5	0.
GRID	48	0.91	7.5	0.
GRID	49	0.92	7.5	0.
GRID	50	0.96	7.5	0.
GRID	51	1.0	7.5	0.
GRID	52	0.	0.	0.001
GRID	53	0.02	0.	0.001
GRID	54	0.06	0.	0.001
GRID	55	0.14	0.	0.001
GRID	56	0.3	0.	0.001
GRID	57	0.54	0.	0.001
GRID	58	0.78	0.	0.001
GRID	59	0.86	0.	0.001
GRID	60	0.9	0.	0.001
GRID	61	0.92	0.	0.001
GRID	62	1.0	0.	0.001
GRID	63	0.02	7.5	0.001

GRID	64	0.06	7.5	0.001
GRID	65	0.14	7.5	0.001
GRID	66	0.3	7.5	0.001
GRID	67	0.54	7.5	0.001
GRID	68	0.78	7.5	0.001
GRID	69	0.86	7.5	0.001
GRID	70	0.9	7.5	0.001
GRID	71	0.92	7.5	0.001
GRID	72	1.0	7.5	0.001
GRID	73	0.	0.	0.002
GRID	74	0.01	0.	0.002
GRID	75	0.02	0.	0.002
GRID	76	0.04	0.	0.002
GRID	77	0.06	0.	0.002
GRID	78	0.1	0.	0.002
GRID	79	0.14	0.	0.002
GRID	80	0.22	0.	0.002
GRID	81	0.3	0.	0.002
GRID	82	0.42	0.	0.002
GRID	83	0.54	0.	0.002
GRID	84	0.66	0.	0.002
GRID	85	0.78	0.	0.002
GRID	86	0.82	0.	0.002
GRID	87	0.86	0.	0.002
GRID	88	0.88	0.	0.002
GRID	89	0.90	0.	0.002
GRID	90	0.91	0.	0.002
GRID	91	0.92	0.	0.002
GRID	92	0.96	0.	0.002
GRID	93	1.0	0.	0.002
GRID	94	0.02	3.75	0.002
GRID	95	0.06	3.75	0.002
GRID	96	0.14	3.75	0.002
GRID	97	0.30	3.75	0.002
GRID	98	0.54	3.75	0.002
GRID	99	0.78	3.75	0.002
GRID	100	0.86	3.75	0.002
GRID	101	0.90	3.75	0.002
GRID	102	0.92	3.75	0.002
GRID	103	1.0	3.75	0.002
GRID	104	0.01	7.5	0.002
GRID	105	0.02	7.5	0.002
GRID	106	0.04	7.5	0.002
GRID	107	0.06	7.5	0.002
GRID	108	0.1	7.5	0.002
GRID	109	0.14	7.5	0.002
GRID	110	0.22	7.5	0.002
GRID	111	0.30	7.5	0.002
GRID	112	0.42	7.5	0.002
GRID	113	0.54	7.5	0.002
GRID	114	0.66	7.5	0.002
GRID	115	0.78	7.5	0.002
GRID	116	0.82	7.5	0.002
GRID	117	0.86	7.5	0.002
GRID	118	0.88	7.5	0.002

GRID	119	0.90	7.5	0.002
GRID	120	0.91	7.5	0.002
GRID	121	0.92	7.5	0.002
GRID	122	0.96	7.5	0.002
GRID	123	1.0	7.5	0.002
GRID	124	0.	0.	0.006
GRID	125	0.02	0.	0.006
GRID	126	0.06	0.	0.006
GRID	127	0.14	0.	0.006
GRID	128	0.30	0.	0.006
GRID	129	0.54	0.	0.006
GRID	130	0.78	0.	0.006
GRID	131	0.86	0.	0.006
GRID	132	0.90	0.	0.006
GRID	133	0.92	0.	0.006
GRID	134	1.0	0.	0.006
GRID	135	0.02	7.5	0.006
GRID	136	0.06	7.5	0.006
GRID	137	0.14	7.5	0.006
GRID	138	0.30	7.5	0.006
GRID	139	0.54	7.5	0.006
GRID	140	0.78	7.5	0.006
GRID	141	0.86	7.5	0.006
GRID	142	0.90	7.5	0.006
GRID	143	0.92	7.5	0.006
GRID	144	1.0	7.5	0.006
GRID	145	0.	0.	0.010
GRID	146	0.01	0.	0.010
GRID	147	0.02	0.	0.010
GRID	148	0.04	0.	0.010
GRID	149	0.06	0.	0.010
GRID	150	0.1	0.	0.010
GRID	151	0.14	0.	0.010
GRID	152	0.22	0.	0.010
GRID	153	0.3	0.	0.010
GRID	154	0.42	0.	0.010
GRID	155	0.54	0.	0.010
GRID	156	0.66	0.	0.010
GRID	157	0.78	0.	0.010
GRID	158	0.82	0.	0.010
GRID	159	0.86	0.	0.010
GRID	160	0.88	0.	0.010
GRID	161	0.9	0.	0.010
GRID	162	0.91	0.	0.010
GRID	163	0.92	0.	0.010
GRID	164	0.96	0.	0.010
GRID	165	1.0	0.	0.010
GRID	166	0.02	3.75	0.010
GRID	167	0.06	3.75	0.010
GRID	168	0.14	3.75	0.010
GRID	169	0.3	3.75	0.010
GRID	170	0.54	3.75	0.010
GRID	171	0.78	3.75	0.010
GRID	172	0.86	3.75	0.010
GRID	173	0.9	3.75	0.010

GRID	174	0.92	3.75	0.010
GRID	175	1.0	3.75	0.010
GRID	176	0.01	7.5	0.010
GRID	177	0.02	7.5	0.010
GRID	178	0.04	7.5	0.010
GRID	179	0.06	7.5	0.010
GRID	180	0.1	7.5	0.010
GRID	181	0.14	7.5	0.010
GRID	182	0.22	7.5	0.010
GRID	183	0.30	7.5	0.010
GRID	184	0.42	7.5	0.010
GRID	185	0.54	7.5	0.010
GRID	186	0.66	7.5	0.010
GRID	187	0.78	7.5	0.010
GRID	188	0.82	7.5	0.010
GRID	189	0.86	7.5	0.010
GRID	190	0.88	7.5	0.010
GRID	191	0.9	7.5	0.010
GRID	192	0.91	7.5	0.010
GRID	193	0.92	7.5	0.010
GRID	194	0.96	7.5	0.010
GRID	195	1.0	7.5	0.010
GRID	196	0.00	0.	0.02275
GRID	197	0.02	0.	0.02275
GRID	198	0.06	0.	0.02275
GRID	199	0.14	0.	0.02275
GRID	200	0.30	0.	0.02275
GRID	201	0.54	0.	0.02275
GRID	202	0.78	0.	0.02275
GRID	203	0.86	0.	0.02275
GRID	204	0.90	0.	0.02275
GRID	205	0.92	0.	0.02275
GRID	206	1.0	0.	0.02275
GRID	207	0.02	7.5	0.02275
GRID	208	0.06	7.5	0.02275
GRID	209	0.14	7.5	0.02275
GRID	210	0.3	7.5	0.02275
GRID	211	0.54	7.5	0.02275
GRID	212	0.78	7.5	0.02275
GRID	213	0.86	7.5	0.02275
GRID	214	0.90	7.5	0.02275
GRID	215	0.92	7.5	0.02275
GRID	216	1.0	7.5	0.02275
GRID	217	0.	0.	0.0355
GRID	218	0.01	0.	0.0355
GRID	219	0.02	0.	0.0355
GRID	220	0.04	0.	0.0355
GRID	221	0.06	0.	0.0355
GRID	222	0.1	0.	0.0355
GRID	223	0.14	0.	0.0355
GRID	224	0.22	0.	0.0355
GRID	225	0.3	0.	0.0355
GRID	226	0.42	0.	0.0355
GRID	227	0.54	0.	0.0355
GRID	228	0.66	0.	0.0355

GRID	229	0.78	0.	0.0355
GRID	230	0.82	0.	0.0355
GRID	231	0.86	0.	0.0355
GRID	232	0.88	0.	0.0355
GRID	233	0.9	0.	0.0355
GRID	234	0.91	0.	0.0355
GRID	235	0.92	0.	0.0355
GRID	236	0.96	0.	0.0355
GRID	237	1.	0.	0.0355
GRID	238	0.02	3.75	0.0355
GRID	239	0.06	3.75	0.0355
GRID	240	0.14	3.75	0.0355
GRID	241	0.3	3.75	0.0355
GRID	242	0.54	3.75	0.0355
GRID	243	0.78	3.75	0.0355
GRID	244	0.86	3.75	0.0355
GRID	245	0.9	3.75	0.0355
GRID	246	0.92	3.75	0.0355
GRID	247	1.	3.75	0.0355
GRID	248	0.01	7.5	0.0355
GRID	249	0.02	7.5	0.0355
GRID	250	0.04	7.5	0.0355
GRID	251	0.06	7.5	0.0355
GRID	252	0.1	7.5	0.0355
GRID	253	0.14	7.5	0.0355
GRID	254	0.22	7.5	0.0355
GRID	255	0.3	7.5	0.0355
GRID	256	0.42	7.5	0.0355
GRID	257	0.54	7.5	0.0355
GRID	258	0.66	7.5	0.0355
GRID	259	0.78	7.5	0.0355
GRID	260	0.82	7.5	0.0355
GRID	261	0.86	7.5	0.0355
GRID	262	0.88	7.5	0.0355
GRID	263	0.9	7.5	0.0355
GRID	264	0.91	7.5	0.0355
GRID	265	0.92	7.5	0.0355
GRID	266	0.96	7.5	0.0355
GRID	267	1.	7.5	0.0355
GRID	268	0.	0.	0.053
GRID	269	0.02	0.	0.053
GRID	270	0.06	0.	0.053
GRID	271	0.14	0.	0.053
GRID	272	0.3	0.	0.053
GRID	273	0.54	0.	0.053
GRID	274	0.78	0.	0.053
GRID	275	0.86	0.	0.053
GRID	276	0.9	0.	0.053
GRID	277	0.92	0.	0.053
GRID	278	1.	0.	0.053
GRID	279	0.02	7.5	0.053
GRID	280	0.06	7.5	0.053
GRID	281	0.14	7.5	0.053
GRID	282	0.3	7.5	0.053
GRID	283	0.54	7.5	0.053

GRID	284	0.78	7.5	0.053
GRID	285	0.86	7.5	0.053
GRID	286	0.9	7.5	0.053
GRID	287	0.92	7.5	0.053
GRID	288	1.0	7.5	0.053
GRID	289	0.	0.	0.071
GRID	290	0.01	0.	0.071
GRID	291	0.02	0.	0.071
GRID	292	0.04	0.	0.071
GRID	293	0.06	0.	0.071
GRID	294	0.1	0.	0.071
GRID	295	0.14	0.	0.071
GRID	296	0.22	0.	0.071
GRID	297	0.3	0.	0.071
GRID	298	0.42	0.	0.071
GRID	299	0.54	0.	0.071
GRID	300	0.66	0.	0.071
GRID	301	0.78	0.	0.071
GRID	302	0.82	0.	0.071
GRID	303	0.86	0.	0.071
GRID	304	0.88	0.	0.071
GRID	305	0.9	0.	0.071
GRID	306	0.91	0.	0.071
GRID	307	0.92	0.	0.071
GRID	308	0.96	0.	0.071
GRID	309	1.	0.	0.071
GRID	310	0.02	3.75	0.071
GRID	311	0.06	3.75	0.071
GRID	312	0.14	3.75	0.071
GRID	313	0.3	3.75	0.071
GRID	314	0.54	3.75	0.071
GRID	315	0.78	3.75	0.071
GRID	316	0.86	3.75	0.071
GRID	317	0.9	3.75	0.071
GRID	318	0.92	3.75	0.071
GRID	319	1.	3.75	0.071
GRID	320	0.01	7.5	0.071
GRID	321	0.02	7.5	0.071
GRID	322	0.04	7.5	0.071
GRID	323	0.06	7.5	0.071
GRID	324	0.1	7.5	0.071
GRID	325	0.14	7.5	0.071
GRID	326	0.22	7.5	0.071
GRID	327	0.3	7.5	0.071
GRID	328	0.42	7.5	0.071
GRID	329	0.54	7.5	0.071
GRID	330	0.66	7.5	0.071
GRID	331	0.78	7.5	0.071
GRID	332	0.82	7.5	0.071
GRID	333	0.86	7.5	0.071
GRID	334	0.88	7.5	0.071
GRID	335	0.9	7.5	0.071
GRID	336	0.91	7.5	0.071
GRID	337	0.92	7.5	0.071
GRID	338	0.96	7.5	0.071

```

GRID      339          1.      7.5      0.071
PSOLID    100        300      5          0
MAT1      300        5.87+7      0.25
TEMPD,2,70.
PARAM     EST        1
LOADCYH   10        1.0      0          1.0      20
CYAX      1         52       73       124      145      196      217      268      +CY
+CY       289
PLOAD4    20        31       210.          289
PLOAD4    20        32       210.          291      323
PLOAD4    20        33       210.          293      325
PLOAD4    20        34       210.          295      327
PLOAD4    20        35       210.          297      329
PLOAD4    20        36       210.          299      331
PLOAD4    20        37       210.          301      333
PLOAD4    20        38       210.          303      335
PLOAD4    20        39       210.          305      337
SPC1      1         3        19       30       49
ENDDATA
EOF
mscnast  in=exlnastin

```

NASTRAN INPUT FILE—AXISYMMETRIC ELEMENTS

```

# USER=_____ PW=_____
# QSUB -r   example1           # JOB NAME
# QSUB -eo                               # combine stderr and stdout
# QSUB -1M 1.0mw                # set memory limit
# QSUB -1t 00:01:00            # set cpu time limit
set -vkk
cd
cat >ex1nastin<<"EOF"
NASTRAN DAYLIMIT=-1
ID CERAMIC,FRACTURE
APP DISP
SOL 61
TIME 30
CEND
TITLE = TRANSVERSELY LOADED CIRCULAR DISK
SUBTITLE = AXISYMMETRIC ELEMENTS
SET 10=0
SEALL=10
SPC=1
LOAD=10
DISP=ALL
STRESS(PRINT,PUNCH)=ALL
ECHO=PUNCH
OUTPUT(PLOT)
PLOTTER NAST
SET 1=ALL
AXES MX,MY,MZ
PTITLE = TRANSVERESLY LOADED CIRCULAR DISK
FIND SCALE,ORIGIN 1,SET 1
PLOT SYMBOLS 5, LABEL BOTH SHAPE
MAXIMUM DEFORMATION
PLOT STATIC DEFORMATION,SET 1
BEGIN BULK
$. . . . . 2. . . . . 3. . . . . 4. . . . . 5. . . . . 6. . . . . 7. . . . . 8. . . . . 9. . . . . 10. . . . .
GRDSET           5           5           2456
CORD2C  5       0           0.           0.           0.           0.           0.           1.           +C
+C         1.       0.0         0.
TEMPD,2,70.
GRID   1           0.           0.           0.
GRID   2           0.01          0.           0.
GRID   3           0.02          0.           0.
GRID   4           0.04          0.           0.
GRID   5           0.06          0.           0.
GRID   6           0.1           0.           0.
GRID   7           0.14          0.           0.
GRID   8           0.22          0.           0.
GRID   9           0.30          0.           0.
GRID  10           0.42          0.           0.
GRID  11           0.54          0.           0.
GRID  12           0.66          0.           0.
GRID  13           0.78          0.           0.
GRID  14           0.82          0.           0.
GRID  15           0.86          0.           0.
GRID  16           0.88          0.           0.
GRID  17           0.90          0.           0.

```

GRID	18	0.91	0.	0.
GRID	19	0.92	0.	0.
GRID	20	0.96	0.	0.
GRID	21	1.0	0.	0.
GRID	52	0.	0.	0.001
GRID	53	0.02	0.	0.001
GRID	54	0.06	0.	0.001
GRID	55	0.14	0.	0.001
GRID	56	0.3	0.	0.001
GRID	57	0.54	0.	0.001
GRID	58	0.78	0.	0.001
GRID	59	0.86	0.	0.001
GRID	60	0.9	0.	0.001
GRID	61	0.92	0.	0.001
GRID	62	1.0	0.	0.001
GRID	73	0.	0.	0.002
GRID	74	0.01	0.	0.002
GRID	75	0.02	0.	0.002
GRID	76	0.04	0.	0.002
GRID	77	0.06	0.	0.002
GRID	78	0.1	0.	0.002
GRID	79	0.14	0.	0.002
GRID	80	0.22	0.	0.002
GRID	81	0.3	0.	0.002
GRID	82	0.42	0.	0.002
GRID	83	0.54	0.	0.002
GRID	84	0.66	0.	0.002
GRID	85	0.78	0.	0.002
GRID	86	0.82	0.	0.002
GRID	87	0.86	0.	0.002
GRID	88	0.88	0.	0.002
GRID	89	0.90	0.	0.002
GRID	90	0.91	0.	0.002
GRID	91	0.92	0.	0.002
GRID	92	0.96	0.	0.002
GRID	93	1.0	0.	0.002
GRID	124	0.	0.	0.006
GRID	125	0.02	0.	0.006
GRID	126	0.06	0.	0.006
GRID	127	0.14	0.	0.006
GRID	128	0.30	0.	0.006
GRID	129	0.54	0.	0.006
GRID	130	0.78	0.	0.006
GRID	131	0.86	0.	0.006
GRID	132	0.90	0.	0.006
GRID	133	0.92	0.	0.006
GRID	134	1.0	0.	0.006
GRID	145	0.	0.	0.010
GRID	146	0.01	0.	0.010
GRID	147	0.02	0.	0.010
GRID	148	0.04	0.	0.010
GRID	149	0.06	0.	0.010
GRID	150	0.1	0.	0.010
GRID	151	0.14	0.	0.010
GRID	152	0.22	0.	0.010

GRID	153	0.3	0.	0.010
GRID	154	0.42	0.	0.010
GRID	155	0.54	0.	0.010
GRID	156	0.66	0.	0.010
GRID	157	0.78	0.	0.010
GRID	158	0.82	0.	0.010
GRID	159	0.86	0.	0.010
GRID	160	0.88	0.	0.010
GRID	161	0.9	0.	0.010
GRID	162	0.91	0.	0.010
GRID	163	0.92	0.	0.010
GRID	164	0.96	0.	0.010
GRID	165	1.0	0.	0.010
GRID	196	0.00	0.	0.02275
GRID	197	0.02	0.	0.02275
GRID	198	0.06	0.	0.02275
GRID	199	0.14	0.	0.02275
GRID	200	0.30	0.	0.02275
GRID	201	0.54	0.	0.02275
GRID	202	0.78	0.	0.02275
GRID	203	0.86	0.	0.02275
GRID	204	0.90	0.	0.02275
GRID	205	0.92	0.	0.02275
GRID	206	1.0	0.	0.02275
GRID	217	0.	0.	0.0355
GRID	218	0.01	0.	0.0355
GRID	219	0.02	0.	0.0355
GRID	220	0.04	0.	0.0355
GRID	221	0.06	0.	0.0355
GRID	222	0.1	0.	0.0355
GRID	223	0.14	0.	0.0355
GRID	224	0.22	0.	0.0355
GRID	225	0.3	0.	0.0355
GRID	226	0.42	0.	0.0355
GRID	227	0.54	0.	0.0355
GRID	228	0.66	0.	0.0355
GRID	229	0.78	0.	0.0355
GRID	230	0.82	0.	0.0355
GRID	231	0.86	0.	0.0355
GRID	232	0.88	0.	0.0355
GRID	233	0.9	0.	0.0355
GRID	234	0.91	0.	0.0355
GRID	235	0.92	0.	0.0355
GRID	236	0.96	0.	0.0355
GRID	237	1.	0.	0.0355
GRID	268	0.	0.	0.053
GRID	269	0.02	0.	0.053
GRID	270	0.06	0.	0.053
GRID	271	0.14	0.	0.053
GRID	272	0.3	0.	0.053
GRID	273	0.54	0.	0.053
GRID	274	0.78	0.	0.053
GRID	275	0.86	0.	0.053
GRID	276	0.9	0.	0.053
GRID	277	0.92	0.	0.053

GRID	278	1.	0.	0.053
GRID	289	0.	0.	0.071
GRID	290	0.01	0.	0.071
GRID	291	0.02	0.	0.071
GRID	292	0.04	0.	0.071
GRID	293	0.06	0.	0.071
GRID	294	0.1	0.	0.071
GRID	295	0.14	0.	0.071
GRID	296	0.22	0.	0.071
GRID	297	0.3	0.	0.071
GRID	298	0.42	0.	0.071
GRID	299	0.54	0.	0.071
GRID	300	0.66	0.	0.071
GRID	301	0.78	0.	0.071
GRID	302	0.82	0.	0.071
GRID	303	0.86	0.	0.071
GRID	304	0.88	0.	0.071
GRID	305	0.9	0.	0.071
GRID	306	0.91	0.	0.071
GRID	307	0.92	0.	0.071
GRID	308	0.96	0.	0.071
GRID	309	1.	0.	0.071
GRID	22	0.01	0.	.001
GRID	23	0.04	0.	.001
GRID	24	0.1	0.	.001
GRID	25	0.22	0.	.001
GRID	26	0.42	0.	.001
GRID	27	0.66	0.	.001
GRID	28	0.82	0.	.001
GRID	29	0.88	0.	.001
GRID	30	0.91	0.	.001
GRID	31	0.96	0.	.001
GRID	63	0.01	0.	.006
GRID	64	0.04	0.	.006
GRID	65	0.1	0.	.006
GRID	66	0.22	0.	.006
GRID	67	0.42	0.	.006
GRID	68	0.66	0.	.006
GRID	69	0.82	0.	.006
GRID	70	0.88	0.	.006
GRID	71	0.91	0.	.006
GRID	72	0.96	0.	.006
GRID	94	0.01	0.	.02275
GRID	95	0.04	0.	.02275
GRID	96	0.1	0.	.02275
GRID	97	0.22	0.	.02275
GRID	98	0.42	0.	.02275
GRID	99	0.66	0.	.02275
GRID	100	0.82	0.	.02275
GRID	101	0.88	0.	.02275
GRID	102	0.91	0.	.02275
GRID	103	0.96	0.	.02275
GRID	135	0.01	0.	.053
GRID	136	0.04	0.	.053
GRID	137	0.1	0.	.053

GRID	138	0.22	0.	.053				
GRID	139	0.42	0.	.053				
GRID	140	0.66	0.	.053				
GRID	141	0.82	0.	.053				
GRID	142	0.88	0.	.053				
GRID	143	0.91	0.	.053				
GRID	144	0.96	0.	.053				
CTRIAX6	1100		1	2	3	53	75	22
CTRIAX6	2100		1	22	75	74	73	52
CTRIAX6	3100		3	4	5	54	77	23
CTRIAX6	4100		3	23	77	76	75	53
CTRIAX6	5100		5	6	7	55	79	24
CTRIAX6	6100		5	24	79	78	77	54
CTRIAX6	7100		7	8	9	56	81	25
CTRIAX6	8100		7	25	81	80	79	55
CTRIAX6	9100		9	10	11	57	83	26
CTRIAX6	10100		9	26	83	82	81	56
CTRIAX6	11100		11	12	13	58	85	27
CTRIAX6	12100		11	27	85	84	83	57
CTRIAX6	13100		13	14	15	59	87	28
CTRIAX6	14100		13	28	87	86	85	58
CTRIAX6	15100		15	16	17	60	89	29
CTRIAX6	16100		15	29	89	88	87	59
CTRIAX6	17100		17	18	19	61	91	30
CTRIAX6	18100		17	30	91	90	89	60
CTRIAX6	19100		19	20	21	62	93	31
CTRIAX6	20100		19	31	93	92	91	61
CTRIAX6	21100		73	74	75	125	147	63
CTRIAX6	22100		73	63	147	146	145	124
CTRIAX6	23100		75	76	77	126	149	64
CTRIAX6	24100		75	64	149	148	147	125
CTRIAX6	25100		77	78	79	127	151	65
CTRIAX6	26100		77	65	151	150	149	126
CTRIAX6	27100		79	80	81	128	153	66
CTRIAX6	28100		79	66	153	152	151	127
CTRIAX6	29100		81	82	83	129	155	67
CTRIAX6	30100		81	67	155	154	153	128
CTRIAX6	31100		83	84	85	130	157	68
CTRIAX6	32100		83	68	157	156	155	129
CTRIAX6	33100		85	86	87	131	159	69
CTRIAX6	34100		85	69	159	158	157	130
CTRIAX6	35100		87	88	89	132	161	70
CTRIAX6	36100		87	70	161	160	159	131
CTRIAX6	37100		89	90	91	133	163	71
CTRIAX6	38100		89	71	163	162	161	132
CTRIAX6	39100		91	92	93	134	165	72
CTRIAX6	40100		91	72	165	164	163	133
CTRIAX6	41100		145	146	147	197	219	94
CTRIAX6	42100		145	94	219	218	217	196
CTRIAX6	43100		147	148	149	198	221	95
CTRIAX6	44100		147	95	221	220	219	197
CTRIAX6	45100		149	150	151	199	223	96
CTRIAX6	46100		149	96	223	222	221	198
CTRIAX6	47100		151	152	153	200	225	97
CTRIAX6	48100		151	97	225	224	223	199

CTRIAX6	49100	153	154	155	201	227	98
CTRIAX6	50100	153	98	227	226	225	200
CTRIAX6	51100	155	156	157	202	229	99
CTRIAX6	52100	155	99	229	228	227	201
CTRIAX6	53100	157	158	159	203	231	100
CTRIAX6	54100	157	100	231	230	229	202
CTRIAX6	55100	159	160	161	204	233	101
CTRIAX6	56100	159	101	233	232	231	203
CTRIAX6	57100	161	162	163	205	235	102
CTRIAX6	58100	161	102	235	234	233	204
CTRIAX6	59100	163	164	165	206	237	103
CTRIAX6	60100	163	103	237	236	235	205
CTRIAX6	61100	217	218	219	269	291	135
CTRIAX6	62100	217	135	291	290	289	268
CTRIAX6	63100	219	220	221	270	293	136
CTRIAX6	64100	219	136	293	292	291	269
CTRIAX6	65100	221	222	223	271	295	137
CTRIAX6	66100	221	137	295	294	293	270
CTRIAX6	67100	223	224	225	272	297	138
CTRIAX6	68100	223	138	297	296	295	271
CTRIAX6	69100	225	226	227	273	299	139
CTRIAX6	70100	225	139	299	298	297	272
CTRIAX6	71100	227	228	229	274	301	140
CTRIAX6	72100	227	140	301	300	299	273
CTRIAX6	73100	229	230	231	275	303	141
CTRIAX6	74100	229	141	303	302	301	274
CTRIAX6	75100	231	232	233	276	305	142
CTRIAX6	76100	231	142	305	304	303	275
CTRIAX6	77100	233	234	235	277	307	143
CTRIAX6	78100	233	143	307	306	305	276
CTRIAX6	79100	235	236	237	278	309	144
CTRIAX6	80100	235	144	309	308	307	277
MAT1	100	5.87+7	0.25				
PARAM	EST	1					
SPC1,1,3,19							
SPC1,1,456,1,THRU,309							
PLOADX,10,210.,210.,291,290,289							
PLOADX,10,210.,210.,293,292,291							
PLOADX,10,210.,210.,295,294,293							
PLOADX,10,210.,210.,297,296,295							
PLOADX,10,210.,210.,299,298,297							
PLOADX,10,210.,210.,301,300,299							
PLOADX,10,210.,210.,303,302,301							
PLOADX,10,210.,210.,305,304,303							
PLOADX,10,210.,210.,307,306,305							
ENDDATA							
EOF							
mcsnast in=exlnastin							

CARES TEMPLET INPUT FILE

*
* RELIABILITY PREDICTION FOR BRITTLE MATERIAL STRUCTURES *
* --- FAST FRACTURE STATISTICS --- *
*

MASTER CONTROL INPUT

TITLE : PROBLEM TITLE (ECHOED IN CARES OUTPUT)

EXAMPLE PROBLEM 1 : TRANSVERSELY LOADED CIRCULAR DISK

NE : CONTROL INDEX FOR FINITE ELEMENT POSTPROCESSING

(DEFAULT: NE = 0)
1 0 : EXPERIMENTAL DATA ANALYSIS ONLY

1 : MSC/NASTRAN ANALYSIS
2 : ANSYS ANALYSIS

NMATS : NO. OF MATERIALS FOR SURFACE FLAW ANALYSIS

(NMATS+NMATV < 101)
01 (DEFAULT: NMATS = 0)

NMATV : NO. OF MATERIALS FOR VOLUME FLAW ANALYSIS

(NMATS+NMATV < 101)
01 (DEFAULT: NMATV = 0)

IPRINT : CONTROL INDEX FOR STRESS OUTPUT

(DEFAULT: IPRINT = 0)
1 0 : DO NOT PRINT ELEMENT STRESSES AND/OR FRACTURE DATA

1 : PRINT ELEMENT STRESSES AND/OR FRACTURE DATA

LONL : CONTROL INDEX FOR LINEAR OR QUADRATIC ELEMENTS

(DEFAULT: LONL = 0)
1 0 : LINEAR

1 : QUADRATIC (MIDSIDE NODES REQUIRED)

NGP : NO. OF GAUSSIAN QUADRATURE POINTS (15 OR 30)

(DEFAULT: NGP = 15)
15

NS : NO. OF SEGMENTS IN CYCLIC SYMMETRY PROBLEM

(DEFAULT: NS = 1)
048

\$ENDX : END OF MASTER CONTROL INPUT

MATERIAL CONTROL INPUT

TITLE : MATERIAL TITLE (ECHOED IN CARES OUTPUT)

ALUMINA SPECIMEN DATA FOR VOLUME FLAW ANALYSIS (REF. RUFIN AND SAMOS)

MATID : MATERIAL IDENTIFICATION NO. FROM THE FINITE ELEMENT

MATERIAL PROPERTY CARD (IF POSTPROCESSING IS NOT
0000300 BEING PERFORMED THIS ENTRY SHOULD BE SOME UNIQUE NO.)

(NO DEFAULT)

ID1 : CONTROL INDEX FOR EXPERIMENTAL DATA

(NO DEFAULT)
3

1 : UNIFORM UNIAXIAL TENSILE SPECIMEN TEST DATA
2 : FOUR-POINT BEND TEST DATA
3 : DIRECT INPUT OF THE WEIBULL PARAMETERS, M AND SP
(SHAPE PARAMETER AND SCALE PARAMETER)
4 : CENSORED DATA FOR SUSPENDED ITEM ANALYSIS OF
UNIFORM UNIAXIAL TENSILE SPECIMEN TEST DATA
5 : CENSORED DATA FOR SUSPENDED ITEM ANALYSIS OF
FOUR-POINT BEND TEST DATA

ID4 : CONTROL INDEX FOR VOLUME OR SURFACE FLAW ANALYSIS

(NO DEFAULT)
1

1 : VOLUME
2 : SURFACE

ID2V : CONTROL INDEX FOR VOLUME FRACTURE CRITERION

(NO DEFAULT)
5

1 : NORMAL STRESS FRACTURE CRITERION
(SHEAR-INSENSITIVE CRACK)
2 : MAXIMUM TENSILE STRESS CRITERION
3 : COPLANAR STRAIN ENERGY RELEASE RATE CRITERION
(G SUB T)
4 : WEIBULL PIA MODEL
5 : SHETTY'S SEMI-EMPIRICAL CRITERION

ID3V : CONTROL INDEX FOR SHAPE OF VOLUME CRACKS

(NO DEFAULT)
2

1 : GRIFFITH CRACK
2 : PENNY-SHAPED CRACK

IKBAT : CONTROL INDEX FOR METHOD OF CALCULATING BATDORF CRACK

DENSITY COEFFICIENT (K SUB B) FROM TEST DATA
0

(DEFAULT: IKBAT = 0)
0 : SHEAR-INSENSITIVE METHOD (MODE I FRACTURE ASSUMED)
1 : SHEAR-SENSITIVE METHOD (FRACTURE ASSUMED TO OCCUR
ACCORDING TO THE FRACTURE CRITERION AND CRACK SHAPE
SELECTED BY THE ID2 AND ID3 INDICES)

PR : POISSON'S RATIO

(DEFAULT: PR = 0.25)

00000.2500

C : CONSTANT FOR SHETTY'S SEMI-EMPIRICAL MIXED-MODE FRACTURE
CRITERION $(K_I/K_{Ic}) + (K_{II}/(C \cdot K_{Ic}))^{**2} = 1$

00000.8000 OBSERVED VALUES RANGE FROM 0.8 TO 2. (REF. D.K. SHETTY)

NOTE: AS C APPROACHES INFINITY, PREDICTED FAILURE
PROBABILITIES APPROACH NORMAL STRESS CRITERION VALUES
(DEFAULT C = 1.0)

\$ENDM : END OF TEMPERATURE INDEPENDENT MATERIAL CONTROL INPUT

TEMPERATURE DEPENDENT MATERIAL CONTROL INPUT DATA
FOR THE ABOVE MATERIAL

!!
PLEASE NOTE THE FOLLOWING:
1. TEMPERATURE DEPENDENT DATA SETS MUST BE ARRANGED IN ASCENDING ORDER
ACCORDING TO TEMPERATURE.
2. MAXIMUM NUMBER OF TEMPERATURE SETS IS 20.
!!

TDEG : TEMPERATURE OF THIS SET

00070.0000

PARAM : WEIBULL MODULUS (SHAPE PARAMETER) AND SCALE PARAMETER
-WEIBULL MODULUS---SCALE PARAMETER-*
0.285300E+02 0.361980E+05

END OF DATA FOR THE ABOVE TEMPERATURE

\$ENDT : END OF DATA FOR THE ABOVE MATERIAL

MATERIAL CONTROL INPUT

TITLE : MATERIAL TITLE (ECHOED IN CARES OUTPUT)

ALUMINA SPECIMEN DATA FOR SURFACE FLAW ANALYSIS (REF. RUFIN AND SAMOS)

MATID : MATERIAL IDENTIFICATION NO. FROM THE FINITE ELEMENT
MATERIAL PROPERTY CARD (IF POSTPROCESSING IS NOT

0000300 BEING PERFORMED THIS ENTRY SHOULD BE SOME UNIQUE NO.)

(NO DEFAULT)

ID1 : CONTROL INDEX FOR EXPERIMENTAL DATA

(NO DEFAULT)
3 1 : UNIFORM UNIAXIAL TENSILE SPECIMEN TEST DATA

2 : FOUR-POINT BEND TEST DATA

- 3 : DIRECT INPUT OF THE WEIBULL PARAMETERS, M AND SP
(SHAPE PARAMETER AND SCALE PARAMETER)
- 4 : CENSORED DATA FOR SUSPENDED ITEM ANALYSIS OF
UNIFORM UNIAXIAL TENSILE SPECIMEN TEST DATA
- 5 : CENSORED DATA FOR SUSPENDED ITEM ANALYSIS OF
FOUR-POINT BEND TEST DATA

ID4 : CONTROL INDEX FOR VOLUME OR SURFACE FLAW ANALYSIS

 (NO DEFAULT)
 2

 1 : VOLUME
 2 : SURFACE

ID2S : CONTROL INDEX FOR SURFACE FRACTURE CRITERION

 (NO DEFAULT)
 5

 1 : NORMAL STRESS FRACTURE CRITERION
 (SHEAR-INSENSITIVE CRACK)
 3 : COPLANAR STRAIN ENERGY RELEASE RATE CRITERION
 (G SUB T)
 4 : WEIBULL PIA MODEL
 5 : SHETTY'S SEMI-EMPIRICAL CRITERION

ID3S : CONTROL INDEX FOR SHAPE OF SURFACE CRACKS

 (NO DEFAULT)
 4

 1 : GRIFFITH CRACK
 (ASSOCIATED WITH STRAIN ENERGY RELEASE RATE CRIT.)
 (ASSOCIATED WITH SHETTY'S SEMI-EMPIRICAL CRITERION)
 3 : GRIFFITH NOTCH
 (ASSOCIATED WITH STRAIN ENERGY RELEASE RATE CRIT.)
 (ASSOCIATED WITH SHETTY'S SEMI-EMPIRICAL CRITERION)
 4 : SEMICIRCULAR CRACK
 (ASSOCIATED WITH SHETTY'S SEMI-EMPIRICAL CRITERION)

IKBAT : CONTROL INDEX FOR METHOD OF CALCULATING BATDORF CRACK

 DENSITY COEFFICIENT (K SUB B) FROM TEST DATA
 0

 (DEFAULT: IKBAT = 0)
 0 : SHEAR-INSENSITIVE METHOD (MODE I FRACTURE ASSUMED)
 1 : SHEAR-SENSITIVE METHOD (FRACTURE ASSUMED TO OCCUR
 ACCORDING TO THE FRACTURE CRITERION AND CRACK SHAPE
 SELECTED BY THE ID2 AND ID3 INDICES)

PR : POISSON'S RATIO

 (DEFAULT: PR = 0.25)
 00000.2500

C : CONSTANT FOR SHETTY'S SEMI-EMPIRICAL MIXED-MODE FRACTURE

 CRITERION $(K_I/K_{IC}) + (K_{II}/(C * K_{IC}))^{**2} = 1$
 00000.8000 OBSERVED VALUES RANGE FROM 0.8 TO 2. (REF. D.K. SHETTY)
 ----- NOTE: AS C APPROACHES INFINITY, PREDICTED FAILURE
 PROBABILITIES APPROACH NORMAL STRESS CRITERION VALUES
 (DEFAULT: C = 1.0)

 \$ENDM : END OF TEMPERATURE INDEPENDENT MATERIAL CONTROL INPUT

TEMPERATURE DEPENDENT MATERIAL CONTROL INPUT DATA
FOR THE ABOVE MATERIAL

!!
PLEASE NOTE THE FOLLOWING:
1. TEMPERATURE DEPENDENT DATA SETS MUST BE ARRANGED IN ASCENDING ORDER
ACCORDING TO TEMPERATURE.
2. MAXIMUM NUMBER OF TEMPERATURE SETS IS 20.
!!

TDEG : TEMPERATURE OF THIS SET

00070.0000

PARAM : WEIBULL MODULUS (SHAPE PARAMETER) AND SCALE PARAMETER
-WEIBULL MODULUS--SCALE PARAMETER-
0.285300E+02 0.458400E+05

END OF DATA FOR THE ABOVE TEMPERATURE

\$ENDT : END OF DATA FOR THE ABOVE MATERIAL

CARES2 OUTPUT FILE

```

@@@@@@@@@@@@@@@@@@@@@@@@@@@@@@@@@@@@@@@@@@@@@@@@@@@@@@@@@@@@@@@@@@@@@@@@@@@@@@@@@@@@@@@@
@@@@
@@@@
@@@@          CCCCCC      A          RRRRRRRR      EEEEEEEEE      SSSSSSSS      @@@@
@@@@          C          C      A A      R          R      E          S          S      @@@@
@@@@          C          C      A A      R          R      E          S          S      @@@@
@@@@          C          C      A A      RRRRRRRR      EEEEEEEEE      SSSSSSSS      @@@@
@@@@          C          C      AAAAAAAAAA      R          R      E          S          S      @@@@
@@@@          C          C      A          A      R          R      E          S          S      @@@@
@@@@          CCCCCC      A          A      R          R      EEEEEEEEE      SSSSSSSS      @@@@
@@@@
@@@@
@@@@          CERAMICS ANALYSIS AND RELIABILITY EVALUATION OF STRUCTURES      @@@@
@@@@
@@@@
@@@@@@@@@@@@@@@@@@@@@@@@@@@@@@@@@@@@@@@@@@@@@@@@@@@@@@@@@@@@@@@@@@@@@@@@@@@@@@@@@@@@@@@@

```

```

*****
*                                *
*          ECHO OF MASTER CONTROL INPUT          *
*                                *
*****

```

TITLE = EXAMPLE PROBLEM 1 : TRANSVERSELY LOADED CIRCULAR DISK

1 = CONTROL INDEX FOR FINITE ELEMENT POSTPROCESSING (NE)
 0 : EXPERIMENTAL DATA ANALYSIS ONLY
 1 : MSC/NASTRAN ANALYSIS
 2 : ANSYS ANALYSIS

1 = NUMBER OF MATERIALS FOR SURFACE FLAW ANALYSIS (NMATS)

1 = NUMBER OF MATERIALS FOR VOLUME FLAW ANALYSIS (NMA TV)

15 = NUMBER OF GAUSSIAN QUADRATURE POINTS, EITHER 15 OR 30 (NGP)

48 = NUMBER OF SEGMENTS IN CYCLIC SYMMETRY PROBLEM (NS)

1 = CONTROL INDEX FOR LINEAR OR QUADRATIC ELEMENTS (LONL)
 0 : LINEAR (MIDSIDE NODES OPTIONAL)
 1 : QUADRATIC (MIDSIDE NODES REQUIRED)

1 = CONTROL INDEX FOR STRESS OUTPUT (IPRINT)
 0 : DO NOT PRINT ELEMENT STRESSES AND/OR FRACTURE DATA
 1 : PRINT ELEMENT STRESSES AND/OR FRACTURE DATA

```
*****
*
*          ECHO OF FINITE ELEMENT ANALYSIS DATA          *
*          PROCESSED BY CARES                             *
*
*****
```

***** RESULTS FROM SEARCH OF MSC/NASTRAN BULK DATA *****

40 = TOTAL NUMBER OF SOLID ELEMENTS FOUND (NE)

36 = NUMBER OF HEXA ELEMENTS (NH)

4 = NUMBER OF PENTA ELEMENTS (NP)

0 = NUMBER OF TRIAX6 AXISYMMETRIC ELEMENTS (NA)

10 = TOTAL NUMBER OF SHELL ELEMENTS (NES)

9 = NUMBER OF QUAD8 SHELL ELEMENTS (NSQ)

1 = NUMBER OF TRIA6 SHELL ELEMENTS (NST)

***** MSC/NASTRAN STRESS ANALYSIS OUTPUT *****

TITLE = TRANSVERSELY LOADED CIRCULAR DISK
 SUBTITLE= SOLID ELEMENTS WITH CYCLIC SYMMETRY MODELING

--- PRINCIPAL STRESSES AT THE CENTER OF EACH SUBELEMENT OR ELEMENT ---

***** NOTE: PENTA ELEMENTS ARE NOT SUBDIVIDED *****

***** NOTE: TRIA6 ELEMENTS ARE NOT SUBDIVIDED *****

ELEMENT TYPE = 67

IEXA ELEMENT OUTPUT

ELEMENT	PRC. STRESS I	PRC. STRESS II	PRC. STRESS III
2	0.4160298901E+05	0.4089150679E+05	-0.1916763728E+02
	0.4076218042E+05	0.4006943457E+05	-0.4189506464E+02
	0.3992695388E+05	0.3924178098E+05	-0.6462316564E+02
	0.4129899040E+05	0.4080934551E+05	-0.9340556666E+02
	0.4054021750E+05	0.4005708059E+05	-0.7931899913E+02
	0.3978161052E+05	0.3930465049E+05	-0.6523317613E+02
	0.4103815224E+05	0.4068418641E+05	-0.1678061313E+03
	0.4033681282E+05	0.4002633301E+05	-0.1169075844E+03
	0.3963991910E+05	0.3936403484E+05	-0.6600997077E+02
	0.4125709972E+05	0.4123739584E+05	-0.1916739186E+02
	0.4044916083E+05	0.4038245336E+05	-0.4189426526E+02
	0.3966092583E+05	0.3950780733E+05	-0.6462147116E+02
	0.4111490750E+05	0.4099342834E+05	-0.9340549707E+02
	0.4036460250E+05	0.4023269534E+05	-0.7931875305E+02
	0.3961429750E+05	0.3947196297E+05	-0.6523263705E+02
	0.4099241917E+05	0.4072991948E+05	-0.1678061244E+03
	0.4028004417E+05	0.4008310164E+05	-0.1169075626E+03
	0.3956766916E+05	0.3943628473E+05	-0.6600992459E+02
	0.4160298901E+05	0.4089150679E+05	-0.1916763358E+02
	0.4076218042E+05	0.4006943457E+05	-0.4189506465E+02
	0.3992695388E+05	0.3924178098E+05	-0.6462316934E+02
	0.4129899040E+05	0.4080934551E+05	-0.9340556444E+02
	0.4054021750E+05	0.4005708059E+05	-0.7931899913E+02
	0.3978161052E+05	0.3930465049E+05	-0.6523317835E+02
	0.4103815224E+05	0.4068418641E+05	-0.1678061306E+03
	0.4033681282E+05	0.4002633301E+05	-0.1169075844E+03
	0.3963991910E+05	0.3936403484E+05	-0.6600997151E+02
3	0.4116936280E+05	0.4091436591E+05	-0.1824403838E+02
	0.4035908195E+05	0.4009758413E+05	-0.3580142129E+02
	0.3955384044E+05	0.3927576510E+05	-0.5336088652E+02
	0.4090012215E+05	0.4052671076E+05	-0.8639471976E+02
	0.4013565073E+05	0.3976291019E+05	-0.8115087524E+02
	0.3937122262E+05	0.3899906966E+05	-0.7591038199E+02
	0.4066583439E+05	0.4010413871E+05	-0.1545813993E+03
	0.3993101767E+05	0.3940947810E+05	-0.1265403553E+03
	0.3919667512E+05	0.3871434820E+05	-0.9850418263E+02
	0.4106419806E+05	0.4101953044E+05	-0.1824381945E+02
	0.4027677750E+05	0.4017988843E+05	-0.3580126153E+02
	0.3948935694E+05	0.3934024850E+05	-0.5336077784E+02
	0.4084844084E+05	0.4057839201E+05	-0.8639464452E+02
	0.4003599250E+05	0.3981256839E+05	-0.8115084039E+02
	0.3932354416E+05	0.3904674811E+05	-0.7591037345E+02
	0.4063268361E+05	0.4013728948E+05	-0.1545813752E+03
	0.3989520750E+05	0.3944528827E+05	-0.1265403370E+03
	0.3915773138E+05	0.3875329191E+05	-0.9850414892E+02

ELEMENT	PRC. STRESS I	PRC. STRESS II	PRC. STRESS III
3	0.4116936280E+05	0.4091436591E+05	-0.1824402375E+02
	0.4035908195E+05	0.4009753413E+05	-0.3580141073E+02
	0.3955384044E+05	0.3927576510E+05	-0.5336088004E+02
	0.4090012215E+05	0.4052671076E+05	-0.8639468920E+02
	0.4013565073E+05	0.3976291019E+05	-0.8115085691E+02
	0.3937122262E+05	0.3899906966E+05	-0.7591037588E+02
	0.4066583439E+05	0.4010413871E+05	-0.1545813528E+03
	0.3993101767E+05	0.3940947810E+05	-0.1265403291E+03
	0.3919667512E+05	0.3871434820E+05	-0.9850417689E+02
	4	0.4041684227E+05	0.3981992633E+05
0.3964317028E+05		0.3903228635E+05	-0.2757119033E+02
0.3886959047E+05		0.3824456465E+05	-0.3733629636E+02
0.3969943890E+05		0.3853349383E+05	-0.7475941401E+02
0.3895136614E+05		0.3780313459E+05	-0.7163689657E+02
0.3820329352E+05		0.3707279290E+05	-0.6853206066E+02
0.3899664645E+05		0.3723245935E+05	-0.1317112197E+03
0.3827282807E+05		0.3656073273E+05	-0.1157185586E+03
0.3754901084E+05		0.3588903203E+05	-0.9975298140E+02
0.4039964112E+05		0.3983712742E+05	-0.1781648198E+02
0.3962733334E+05		0.3904812328E+05	-0.2757117793E+02
0.3885502555E+05		0.3825912956E+05	-0.3733629671E+02
0.3969804000E+05		0.3853489271E+05	-0.7475940093E+02
0.3894999000E+05		0.3780451073E+05	-0.7163689671E+02
0.3820194000E+05		0.3707414639E+05	-0.6853203014E+02
0.3899643889E+05		0.3723266691E+05	-0.1317112200E+03
0.3827264666E+05		0.3656091410E+05	-0.1157185263E+03
0.3754885444E+05		0.3588918831E+05	-0.9975285675E+02
0.4041684227E+05		0.3981992633E+05	-0.1781654342E+02
0.3964317028E+05		0.3903228635E+05	-0.2757119311E+02
0.3886959047E+05	0.3824456465E+05	-0.3733629729E+02	
0.3969943890E+05	0.3853349383E+05	-0.7475941679E+02	
0.3895136614E+05	0.3780313459E+05	-0.7163689823E+02	
0.3820329352E+05	0.3707279290E+05	-0.6853206122E+02	
0.3899664645E+05	0.3723245935E+05	-0.1317112206E+03	
0.3827282807E+05	0.3656073273E+05	-0.1157185591E+03	
0.3754901084E+05	0.3588903203E+05	-0.9975298158E+02	
5	0.3797220098E+05	0.3548090065E+05	0.4958758418E+02
	0.3724681840E+05	0.3478545549E+05	0.4300577527E+02
	0.3652143584E+05	0.3409005850E+05	0.3637578180E+02
	0.3608548119E+05	0.3197061078E+05	0.6886127514E+01
	0.3540303853E+05	0.3136390271E+05	0.8487960519E+01
	0.3472059588E+05	0.3075727215E+05	0.1001229360E+02
	0.3419921178E+05	0.2845987838E+05	-0.3582319268E+02
	0.3355970307E+05	0.2794193249E+05	-0.2605681245E+02
	0.3292019440E+05	0.2742410537E+05	-0.1640925500E+02
	0.3796978335E+05	0.3548331829E+05	0.4958758404E+02
	0.3724442334E+05	0.3478785051E+05	0.4300581376E+02
	0.3651906334E+05	0.3409243082E+05	0.3637595739E+02
	0.3607809334E+05	0.3197799860E+05	0.6886151895E+01
	0.3539578000E+05	0.3137116106E+05	0.8488147925E+01
	0.3471346666E+05	0.3076440085E+05	0.1001280517E+02
	0.3418640333E+05	0.2847268670E+05	-0.3582306662E+02
	0.3354713666E+05	0.2795449840E+05	-0.2605631392E+02
	0.3290786999E+05	0.2743642865E+05	-0.1640812329E+02
	0.3797220098E+05	0.3548090065E+05	0.4958758325E+02
	0.3724681840E+05	0.3478545549E+05	0.4300577249E+02
0.3652143584E+05	0.3409005850E+05	0.3637577717E+02	
0.3608548119E+05	0.3197061078E+05	0.6886126958E+01	
0.3540303853E+05	0.3136390271E+05	0.8487958853E+01	
0.3472059588E+05	0.3075727215E+05	0.1001229082E+02	
0.3419921178E+05	0.2845987838E+05	-0.3582319287E+02	
0.3355970307E+05	0.2794193249E+05	-0.2605681300E+02	
0.3292019440E+05	0.2742410537E+05	-0.1640925592E+02	
6	0.3196480312E+05	0.2436307340E+05	0.6203092256E+02
	0.3135222492E+05	0.2387882820E+05	0.5524825936E+02
	0.3073964676E+05	0.2339478168E+05	0.4826686681E+02
	0.2905930424E+05	0.1895670671E+05	0.3876654677E+02
	0.2850906617E+05	0.1859685483E+05	0.3986270766E+02

ELEMENT	PRC. STRESS I	PRC. STRESS II	PRC. STRESS III
6	0.2795882816E+05	0.1823733634E+05	0.4062542256E+02
	0.2615381502E+05	0.1355035674E+05	0.1547578697E+02
	0.2566591681E+05	0.1331503421E+05	0.2431502615E+02
	0.2517801869E+05	0.1308029993E+05	0.3256592486E+02
	0.3194802141E+05	0.2437985497E+05	0.6203106682E+02
	0.3133569085E+05	0.2389536154E+05	0.5524899086E+02
	0.3072336029E+05	0.2341106635E+05	0.4826866566E+02
	0.2903783750E+05	0.1897817314E+05	0.3876685467E+02
	0.2848795250E+05	0.1861796701E+05	0.3986420266E+02
	0.2793806750E+05	0.1825809337E+05	0.4062905017E+02
	0.2612765360E+05	0.1357651747E+05	0.1547647822E+02
	0.2564021415E+05	0.1334073350E+05	0.2431839012E+02
	0.2515277471E+05	0.1310553576E+05	0.3257408083E+02
	0.3196480312E+05	0.2436307340E+05	0.6203092284E+02
	0.3135222492E+05	0.2387882820E+05	0.5524825953E+02
	0.3073964676E+05	0.2339478168E+05	0.4826686686E+02
	0.2905930424E+05	0.1895670671E+05	0.3876654760E+02
	0.2850906617E+05	0.1859685483E+05	0.3986270816E+02
	0.2795882816E+05	0.1823733634E+05	0.4062542273E+02
	0.2615381502E+05	0.1355035674E+05	0.1547578835E+02
	0.2566591681E+05	0.1331503421E+05	0.2431502699E+02
	0.2517801869E+05	0.1308029993E+05	0.3256592514E+02
7	0.2407408192E+05	0.9604930194E+04	-0.4514221914E+02
	0.2359552890E+05	0.9356951858E+04	-0.6689169885E+02
	0.2311697595E+05	0.9109921584E+04	-0.8958931803E+02
	0.2285086691E+05	0.7302638633E+04	-0.9029551298E+02
	0.2241560594E+05	0.7162876868E+04	-0.9553172775E+02
	0.2198034507E+05	0.7024236172E+04	-0.1018891052E+03
	0.2162766718E+05	0.5000726034E+04	-0.1358430525E+03
	0.2123569792E+05	0.4969590525E+04	-0.1249753306E+03
	0.2084372875E+05	0.4939864883E+04	-0.1155175735E+03
	0.2404471529E+05	0.9634296341E+04	-0.4514172924E+02
	0.2356656584E+05	0.9385910274E+04	-0.6688705671E+02
	0.2308841639E+05	0.9138467786E+04	-0.8957596407E+02
	0.2282035250E+05	0.7333150746E+04	-0.9029321897E+02
	0.2238559750E+05	0.7192874666E+04	-0.9552108198E+02
	0.2195084250E+05	0.7053713291E+04	-0.1018636506E+03
	0.2159598972E+05	0.5032394826E+04	-0.1358343846E+03
	0.2120462916E+05	0.5000632013E+04	-0.1249480632E+03
	0.2081326860E+05	0.4970268850E+04	-0.1154613915E+03
	0.2407408192E+05	0.9604930194E+04	-0.4514221868E+02
	0.2359552890E+05	0.9356951858E+04	-0.6689169857E+02
	0.2311697595E+05	0.9109921584E+04	-0.8958931794E+02
	0.2285086691E+05	0.7302638633E+04	-0.9029551270E+02
	0.2241560594E+05	0.7162876868E+04	-0.9553172758E+02
	0.2198034507E+05	0.7024236172E+04	-0.1018891052E+03
	0.2162766718E+05	0.5000726034E+04	-0.1358430524E+03
	0.2123569792E+05	0.4969590525E+04	-0.1249753306E+03
	0.2084372875E+05	0.4939864883E+04	-0.1155175735E+03
8	0.2079433418E+05	0.3654426236E+04	-0.1789255978E+03
	0.2035116886E+05	0.3440585768E+04	-0.2261398095E+03
	0.1990800363E+05	0.3229724785E+04	-0.2763336059E+03
	0.2002575575E+05	0.2295319108E+04	-0.5446358523E+03
	0.1964967628E+05	0.2254324183E+04	-0.5218434569E+03
	0.1927359688E+05	0.2218358586E+04	-0.5040804670E+03
	0.1925717732E+05	0.9421796030E+03	-0.9163137375E+03
	0.1894818370E+05	0.1079540404E+04	-0.8290249163E+03
	0.1863919014E+05	0.1224488778E+04	-0.7493237281E+03
	0.2076209612E+05	0.3686661379E+04	-0.1789226729E+03
	0.2031928500E+05	0.3472465458E+04	-0.2261356463E+03
	0.1987647389E+05	0.3261217639E+04	-0.2762967214E+03
	0.1999240167E+05	0.2328666113E+04	-0.5446287756E+03
	0.1961687500E+05	0.2287056522E+04	-0.5217745194E+03
	0.1924134833E+05	0.2250408872E+04	-0.5038822050E+03
	0.1922270722E+05	0.9765164306E+03	-0.9161804612E+03
	0.1891446500E+05	0.1112852671E+04	-0.8286184781E+03
	0.1860622277E+05	0.1256667487E+04	-0.7485350700E+03
	0.2079433418E+05	0.3654426236E+04	-0.1789255978E+03
	0.2035116886E+05	0.3440585768E+04	-0.2261398095E+03

ELEMENT	PRC. STRESS I	PRC. STRESS II	PRC. STRESS III
8	0.1990800363E+05	0.3229724785E+04	-0.2763336059E+03
	0.2002575575E+05	0.2295319108E+04	-0.5446358523E+03
	0.1964967628E+05	0.2254324183E+04	-0.5218434569E+03
	0.1927359688E+05	0.2218358586E+04	-0.5040804670E+03
	0.1925717732E+05	0.9421796030E+03	-0.9163137375E+03
	0.1894818370E+05	0.1079540404E+04	-0.8290249163E+03
	0.1863919014E+05	0.1224488778E+04	-0.7493237281E+03
9	0.1874097924E+05	0.8510488800E+03	-0.1869009822E+04
	0.1820639844E+05	0.2638728765E+03	-0.1973763826E+04
	0.1767181771E+05	-0.3080537254E+03	-0.2093767309E+04
	0.1731872943E+05	-0.1603222352E+04	-0.4402934653E+04
	0.1685105787E+05	-0.1898455454E+04	-0.4539060739E+04
	0.1638338637E+05	-0.2193686342E+04	-0.4675189107E+04
	0.1589647963E+05	-0.3634079619E+04	-0.7360273456E+04
	0.1549571730E+05	-0.3820510255E+04	-0.7344631186E+04
	0.1509495503E+05	-0.3982614362E+04	-0.7353315506E+04
	0.1870721668E+05	0.8837483960E+03	-0.1867946770E+04
	0.1817254667E+05	0.2971839890E+03	-0.1973223174E+04
	0.1763787667E+05	-0.2741993852E+03	-0.2093680610E+04
	0.1728307000E+05	-0.1568355641E+04	-0.4402141932E+04
	0.1681566000E+05	-0.1863844151E+04	-0.4538274174E+04
	0.1634825000E+05	-0.2159331016E+04	-0.4674408061E+04
	0.1585892333E+05	-0.3601857775E+04	-0.7354938996E+04
	0.1545877333E+05	-0.3787348847E+04	-0.7340848619E+04
	0.1505862332E+05	-0.3948666068E+04	-0.7350932091E+04
	0.1874097924E+05	0.8510488800E+03	-0.1869009822E+04
	0.1820639844E+05	0.2638728765E+03	-0.1973763826E+04
0.1767181771E+05	-0.3080537254E+03	-0.2093767309E+04	
0.1731872943E+05	-0.1603222352E+04	-0.4402934653E+04	
0.1685105787E+05	-0.1898455454E+04	-0.4539060739E+04	
0.1638338637E+05	-0.2193686342E+04	-0.4675189107E+04	
0.1589647963E+05	-0.3634079619E+04	-0.7360273456E+04	
0.1549571730E+05	-0.3820510255E+04	-0.7344631186E+04	
0.1509495503E+05	-0.3982614362E+04	-0.7353315506E+04	
10	0.1524422013E+05	-0.4567290279E+04	-0.7448110815E+04
	0.1501780393E+05	-0.4135788455E+04	-0.7379457314E+04
	0.1479138780E+05	-0.3699766306E+04	-0.7315324206E+04
	0.1575541917E+05	-0.2006895947E+04	-0.5506317707E+04
	0.1540877453E+05	-0.2045610347E+04	-0.5489392638E+04
	0.1506212995E+05	-0.2084065695E+04	-0.5472726671E+04
	0.1626664535E+05	0.5785272467E+03	-0.3589580593E+04
	0.1579977059E+05	0.5877459823E+02	-0.3613560249E+04
	0.1533289583E+05	-0.4609707574E+03	-0.3637547199E+04
	0.1520649222E+05	-0.4529966748E+04	-0.7447706438E+04
	0.1498128333E+05	-0.4099463309E+04	-0.7379261861E+04
	0.1475607444E+05	-0.3664536234E+04	-0.7315240921E+04
	0.1572042334E+05	-0.1971928599E+04	-0.5506289218E+04
	0.1537433000E+05	-0.2011182577E+04	-0.5489375874E+04
	0.1502823666E+05	-0.2050180430E+04	-0.5472718655E+04
	0.1623435445E+05	0.6107976319E+03	-0.3589560080E+04
	0.1576737667E+05	0.9115005171E+02	-0.3613541784E+04
	0.1530039889E+05	-0.4284899347E+03	-0.3637531082E+04
	0.1524422013E+05	-0.4567290279E+04	-0.7448110815E+04
	0.1501780393E+05	-0.4135788455E+04	-0.7379457314E+04
0.1479138780E+05	-0.3699766306E+04	-0.7315324206E+04	
0.1575541917E+05	-0.2006895947E+04	-0.5506317707E+04	
0.1540877453E+05	-0.2045610347E+04	-0.5489392638E+04	
0.1506212995E+05	-0.2084065695E+04	-0.5472726671E+04	
0.1626664535E+05	0.5785272468E+03	-0.3589580593E+04	
0.1579977059E+05	0.5877459845E+02	-0.3613560249E+04	
0.1533289583E+05	-0.4609707570E+03	-0.3637547199E+04	
12	0.3796849837E+05	0.3731128250E+05	0.1191802199E+02
	0.3482441501E+05	0.3422386434E+05	0.1277901634E+02
	0.3168055204E+05	0.3113622711E+05	0.1363869702E+02
	0.3785382392E+05	0.3739895621E+05	0.1063420448E+02
	0.3470922811E+05	0.3429246876E+05	0.5569103373E+01
	0.3156465124E+05	0.3118597034E+05	0.4960327859E+00

ELEMENT	PRC. STRESS I	PRC. STRESS II	PRC. STRESS III
12	0.3773981044E+05 0.3459538498E+05 0.3145112081E+05 0.3773060252E+05 0.3459990417E+05 0.3146920582E+05 0.3769644752E+05 0.3456347250E+05 0.3143049748E+05 0.3766229252E+05 0.3452704083E+05 0.3139178915E+05 0.3796849837E+05 0.3482441501E+05 0.3168055204E+05 0.3785382392E+05 0.3470922811E+05 0.3156465124E+05 0.3773981044E+05 0.3459538498E+05 0.3145112081E+05	0.3748597100E+05 0.3435973475E+05 0.3123335764E+05 0.3754917458E+05 0.3444837108E+05 0.3134756883E+05 0.3755633170E+05 0.3443822328E+05 0.3132012278E+05 0.3756348892E+05 0.3442807889E+05 0.3129268926E+05 0.3731128250E+05 0.3422386434E+05 0.3113622711E+05 0.3739895621E+05 0.3429246876E+05 0.3118597034E+05 0.3748597100E+05 0.3435973475E+05 0.3123335764E+05	0.9348347019E+01 -0.1646146697E+01 -0.1266105559E+02 0.1192180370E+02 0.1278312050E+02 0.1364318790E+02 0.1063512456E+02 0.5570200213E+01 0.4973462312E+00 0.9348348197E+01 -0.1646140876E+01 -0.1266102110E+02 0.1191802662E+02 0.1277901911E+02 0.1363869795E+02 0.1063420726E+02 0.5569105039E+01 0.4960333412E+00 0.9348347945E+01 -0.1646146141E+01 -0.1266105541E+02
13	0.3760635697E+05 0.3448475273E+05 0.3136318243E+05 0.3744547546E+05 0.3433546573E+05 0.3122546878E+05 0.3728909731E+05 0.3419065123E+05 0.3109221694E+05 0.3755099057E+05 0.3443303167E+05 0.3131507276E+05 0.3740050835E+05 0.3429394500E+05 0.3118738165E+05 0.3725002613E+05 0.3415485833E+05 0.3105969054E+05 0.3760635702E+05 0.3448475276E+05 0.3136318244E+05 0.3744547549E+05 0.3433546575E+05 0.3122546879E+05 0.3728909732E+05 0.3419065124E+05 0.3109221695E+05	0.3732905984E+05 0.3423207144E+05 0.3113508929E+05 0.3708870214E+05 0.3400889333E+05 0.3092913747E+05 0.3684386277E+05 0.3378127996E+05 0.3071878311E+05 0.3738442622E+05 0.3428379249E+05 0.3118319889E+05 0.3713366924E+05 0.3405041394E+05 0.3096722424E+05 0.3688293385E+05 0.3381707248E+05 0.3075130863E+05 0.3732905978E+05 0.3423207141E+05 0.3113508928E+05 0.3708870211E+05 0.3400889331E+05 0.3092913746E+05 0.3684386276E+05 0.3378127995E+05 0.3071878311E+05	-0.2026685211E+02 -0.2249529838E+02 -0.2476393736E+02 -0.4013891931E+02 -0.4268005599E+02 -0.4528692542E+02 -0.6003266644E+02 -0.6290204891E+02 -0.6586918774E+02 -0.2026684149E+02 -0.2249529223E+02 -0.2476386886E+02 -0.4013890635E+02 -0.4267993694E+02 -0.4528656421E+02 -0.6003256501E+02 -0.6290167172E+02 -0.6586830540E+02 -0.2026684979E+02 -0.2249529699E+02 -0.2476393689E+02 -0.4013891793E+02 -0.4268005515E+02 -0.4528692514E+02 -0.6003266598E+02 -0.6290204863E+02 -0.6586918765E+02
14	0.3695442715E+05 0.3388541874E+05 0.3081641866E+05 0.3632483086E+05 0.3330810219E+05 0.3029137592E+05 0.3570622162E+05 0.3274091241E+05 0.2977560399E+05 0.3694098752E+05 0.3387300584E+05 0.3080502415E+05 0.3632353585E+05 0.3330689750E+05 0.3029025915E+05 0.3570608418E+05 0.3274078916E+05 0.2977549415E+05 0.3695442715E+05 0.3388541874E+05 0.3081641866E+05	0.3634773088E+05 0.3332973133E+05 0.3031192491E+05 0.3524791605E+05 0.3232079428E+05 0.2939401356E+05 0.3413716777E+05 0.3130185812E+05 0.2846707724E+05 0.3636117043E+05 0.3334214372E+05 0.3032331807E+05 0.3524921079E+05 0.3232199788E+05 0.2939512771E+05 0.3413730463E+05 0.3130197939E+05 0.2846718260E+05 0.3634773088E+05 0.3332973133E+05 0.3031192491E+05	-0.2593874362E+02 -0.3009084688E+02 -0.3444442603E+02 -0.5535054808E+02 -0.5587764054E+02 -0.5674818333E+02 -0.8481595092E+02 -0.8179208852E+02 -0.7929777634E+02 -0.2593865355E+02 -0.3009034247E+02 -0.3444307685E+02 -0.5535027640E+02 -0.5587655042E+02 -0.5674556257E+02 -0.8481537121E+02 -0.8179011048E+02 -0.7929330105E+02 -0.2593874177E+02 -0.3009084576E+02 -0.3444442566E+02

ELEMENT	PRC. STRESS I	PRC. STRESS II	PRC. STRESS III
14	0.3632483086E+05 0.3330810219E+05 0.3029137592E+05 0.3570622162E+05 0.3274091241E+05 0.2977560399E+05	0.3524791605E+05 0.3232079428E+05 0.2939401356E+05 0.3413716777E+05 0.3130185812E+05 0.2846707724E+05	-0.5535054697E+02 -0.5587763988E+02 -0.5674818310E+02 -0.8481595055E+02 -0.8179208830E+02 -0.7929777626E+02
15	0.3471809760E+05 0.3183653821E+05 0.2895497907E+05 0.3300834805E+05 0.3026826196E+05 0.2752817593E+05 0.3129901793E+05 0.2870037354E+05 0.2610172923E+05 0.3471583808E+05 0.3183448417E+05 0.2895313027E+05 0.3300157418E+05 0.3026207250E+05 0.2752257082E+05 0.3128731028E+05 0.2868966083E+05 0.2609201137E+05 0.3471809760E+05 0.3183653821E+05 0.2895497907E+05 0.3300834805E+05 0.3026826196E+05 0.2752817593E+05 0.3129901793E+05 0.2870037354E+05 0.2610172923E+05	0.3239896394E+05 0.2971238887E+05 0.2702674364E+05 0.2923976838E+05 0.2681409048E+05 0.2438991873E+05 0.2608036377E+05 0.2391597483E+05 0.2175390778E+05 0.3240122253E+05 0.2971443963E+05 0.2702858494E+05 0.2924654006E+05 0.2682027337E+05 0.2439550974E+05 0.2609206706E+05 0.2392667547E+05 0.2176360066E+05 0.3239896394E+05 0.2971238887E+05 0.2702674364E+05 0.2923976838E+05 0.2681409048E+05 0.2438991873E+05 0.2608036377E+05 0.2391597483E+05 0.2175390778E+05	0.3167509161E+02 0.2763931603E+02 0.2267345036E+02 0.7295741644E+01 0.5505967766E+01 0.2209988027E+01 -0.1729399253E+02 -0.1719793821E+02 -0.1942386457E+02 0.3167602713E+02 0.2764259602E+02 0.2268094865E+02 0.7297927616E+01 0.5512540143E+01 0.2224099251E+01 -0.1728962981E+02 -0.1718586567E+02 -0.1939888309E+02 0.3167509161E+02 0.2763931603E+02 0.2267345036E+02 0.7295741644E+01 0.5505967766E+01 0.2209988027E+01 -0.1729399253E+02 -0.1719793821E+02 -0.1942386457E+02
16	0.2921970853E+05 0.2679573885E+05 0.2437176927E+05 0.2658019908E+05 0.2437253424E+05 0.2216486948E+05 0.2394069816E+05 0.2194933721E+05 0.1995797636E+05 0.2920420197E+05 0.2678154918E+05 0.2435889639E+05 0.2656044251E+05 0.2435443750E+05 0.2214843249E+05 0.2391668305E+05 0.2192732582E+05 0.1993796859E+05 0.2921970853E+05 0.2679573885E+05 0.2437176927E+05 0.2658019908E+05 0.2437253424E+05 0.2216486948E+05 0.2394069816E+05 0.2194933721E+05 0.1995797636E+05	0.2223199506E+05 0.2039568358E+05 0.1856321670E+05 0.1733987463E+05 0.1590716721E+05 0.1448088332E+05 0.1244916025E+05 0.1142314086E+05 0.1040837937E+05 0.2224749426E+05 0.2040985221E+05 0.1857604542E+05 0.1735961701E+05 0.1592522310E+05 0.1449723443E+05 0.1247314473E+05 0.1144506286E+05 0.1042819856E+05 0.2223199506E+05 0.2039568358E+05 0.1856321670E+05 0.1733987463E+05 0.1590716721E+05 0.1448088332E+05 0.1244916025E+05 0.1142314086E+05 0.1040837937E+05	0.3845693039E+02 0.3389910517E+02 0.2549658699E+02 0.3741473657E+02 0.2494455807E+02 0.6050756873E+01 0.3495794019E+02 0.1149239960E+02 -0.2323114566E+02 0.3846428800E+02 0.3392014328E+02 0.2554073696E+02 0.3742892145E+02 0.2498539942E+02 0.6136650979E+01 0.3498857310E+02 0.1158179167E+02 -0.2304256808E+02 0.3845693039E+02 0.3389910517E+02 0.2549658699E+02 0.3741473657E+02 0.2494455807E+02 0.6050756873E+01 0.3495794019E+02 0.1149239960E+02 -0.2323114566E+02
17	0.2197459210E+05 0.2015405241E+05 0.1833351282E+05 0.2090935240E+05 0.1917286908E+05 0.1743638583E+05 0.1984412647E+05 0.1819169829E+05	0.8650278874E+04 0.7971371668E+04 0.7310150568E+04 0.6702770313E+04 0.6176411786E+04 0.5671383670E+04 0.4759843128E+04 0.4391680902E+04	-0.8293762345E+02 -0.9758734840E+02 -0.1299232704E+03 -0.6847293307E+02 -0.9226030887E+02 -0.1373781631E+03 -0.5860337974E+02 -0.9717480974E+02

ELEMENT	PRC. STRESS I	PRC. STRESS II	PRC. STRESS III
17	0.1653927017E+05	0.4051059874E+04	-0.1632874898E+03
	0.2194738724E+05	0.8677418512E+04	-0.8287239718E+02
	0.2012914167E+05	0.7996093821E+04	-0.9739875894E+02
	0.1831089611E+05	0.7332374799E+04	-0.1295307897E+03
	0.2088127834E+05	0.6730731443E+04	-0.6836000054E+02
	0.1914713500E+05	0.6201842365E+04	-0.9195680513E+02
	0.1741299166E+05	0.5694169576E+04	-0.1367698999E+03
	0.1981516945E+05	0.4788571377E+04	-0.5837460673E+02
	0.1816512833E+05	0.4417677629E+04	-0.9660157170E+02
	0.1651508721E+05	0.4074145688E+04	-0.1621903436E+03
	0.2197459210E+05	0.8650278874E+04	-0.8293762345E+02
	0.2015405241E+05	0.7971371668E+04	-0.9758734840E+02
	0.1833351282E+05	0.7310150568E+04	-0.1299232704E+03
	0.2090935240E+05	0.6702770313E+04	-0.6847293307E+02
	0.1917286908E+05	0.6176411786E+04	-0.9226030887E+02
	0.1743638583E+05	0.5671383670E+04	-0.1373781631E+03
	0.1984412647E+05	0.4759843128E+04	-0.5860337974E+02
	0.1819169829E+05	0.4391680902E+04	-0.9717480974E+02
	0.1653927017E+05	0.4051059874E+04	-0.1632874898E+03
18	0.1896054459E+05	0.3091480146E+04	-0.1442035728E+03
	0.1739077703E+05	0.2929809790E+04	-0.2049505051E+03
	0.1582100951E+05	0.2814981706E+04	-0.3125397534E+03
	0.1842467350E+05	0.2203020260E+04	-0.1631557663E+03
	0.1685501940E+05	0.2054549125E+04	-0.3360607779E+03
	0.1528536534E+05	0.1988605990E+04	-0.5914938301E+03
	0.1788880242E+05	0.1316498018E+04	-0.1840456163E+03
	0.1631926177E+05	0.1216525332E+04	-0.5044079312E+03
	0.1474972116E+05	0.1240343004E+04	-0.9485606398E+03
	0.1893038168E+05	0.3121299923E+04	-0.1438604370E+03
	0.1736315167E+05	0.2956355498E+04	-0.2038708529E+03
	0.1579592166E+05	0.2837937477E+04	-0.3104076722E+03
	0.1839386167E+05	0.2233402529E+04	-0.1627262127E+03
	0.1682668500E+05	0.2080971019E+04	-0.3341482750E+03
	0.1525950833E+05	0.2010576605E+04	-0.5876074329E+03
	0.1785734167E+05	0.1347298907E+04	-0.1833857604E+03
	0.1629021833E+05	0.1241576732E+04	-0.5004158886E+03
	0.1472309499E+05	0.1259821848E+04	-0.9414133090E+03
	0.1896054459E+05	0.3091480146E+04	-0.1442035729E+03
	0.1739077703E+05	0.2929809790E+04	-0.2049505051E+03
	0.1582100951E+05	0.2814981706E+04	-0.3125397534E+03
	0.1842467350E+05	0.2203020260E+04	-0.1631557663E+03
	0.1685501940E+05	0.2054549125E+04	-0.3360607780E+03
	0.1528536534E+05	0.1988605991E+04	-0.5914938301E+03
	0.1788880242E+05	0.1316498018E+04	-0.1840456164E+03
	0.1631926177E+05	0.1216525332E+04	-0.5044079312E+03
	0.1474972116E+05	0.1240343004E+04	-0.9485606398E+03
19	0.1687215063E+05	-0.4765705767E+03	-0.1509908793E+04
	0.1531145641E+05	-0.5034812141E+03	-0.1947224845E+04
	0.1375076222E+05	-0.3436684506E+03	-0.2571264319E+04
	0.1577105674E+05	-0.1049883128E+04	-0.4688060271E+04
	0.1441011212E+05	-0.9235586172E+03	-0.4540087506E+04
	0.1304916755E+05	-0.7859539108E+03	-0.4403394976E+04
	0.1466996291E+05	-0.1418317003E+04	-0.8071090483E+04
	0.1350876789E+05	-0.1342249237E+04	-0.7134337008E+04
	0.1234757294E+05	-0.1138538284E+04	-0.6325226787E+04
	0.1683966862E+05	-0.4443794144E+03	-0.1509617953E+04
	0.1528135584E+05	-0.4796021281E+03	-0.1941003357E+04
	0.1372304305E+05	-0.3260376595E+03	-0.2561175943E+04
	0.1573788917E+05	-0.1026322051E+04	-0.4678453784E+04
	0.1437999750E+05	-0.9011483946E+03	-0.4532383105E+04
	0.1302210583E+05	-0.7649395718E+03	-0.4397347594E+04
	0.1463610972E+05	-0.1397443554E+04	-0.8058110747E+04
	0.1347863916E+05	-0.1320765018E+04	-0.7125692497E+04
	0.1232116860E+05	-0.1116803478E+04	-0.6320557250E+04
	0.1687215063E+05	-0.4765705767E+03	-0.1509908793E+04
	0.1531145641E+05	-0.5034812141E+03	-0.1947224845E+04
	0.1375076222E+05	-0.3436684506E+03	-0.2571264319E+04
	0.1577105674E+05	-0.1049883128E+04	-0.4688060271E+04
	0.1441011212E+05	-0.9235586172E+03	-0.4540087506E+04

ELEMENT	PRC. STRESS I	PRC. STRESS II	PRC. STRESS III
19	0.1304916755E+05	-0.7859539108E+03	-0.4403394976E+04
	0.1466996291E+05	-0.1418317003E+04	-0.8071090483E+04
	0.1350876789E+05	-0.1342249237E+04	-0.7134337008E+04
	0.1234757294E+05	-0.1138538284E+04	-0.6325226787E+04
20	0.1442562674E+05	-0.2706687404E+04	-0.6300758088E+04
	0.1318426366E+05	-0.2344151537E+04	-0.6092964442E+04
	0.1194290058E+05	-0.1952741354E+04	-0.5914045120E+04
	0.1456074181E+05	-0.1742416294E+04	-0.4461092052E+04
	0.1322915301E+05	-0.1756794755E+04	-0.4419974178E+04
	0.1189756421E+05	-0.1768247870E+04	-0.4381781659E+04
	0.1469587850E+05	-0.6070073269E+03	-0.2792585497E+04
	0.1327406150E+05	-0.1070597401E+04	-0.2845843633E+04
	0.1185224453E+05	-0.1534081313E+04	-0.2899207950E+04
	0.1439250834E+05	-0.2675570022E+04	-0.6298757064E+04
	0.1315436500E+05	-0.2315215791E+04	-0.6092001529E+04
	0.1191622166E+05	-0.1926430721E+04	-0.5913676832E+04
	0.1452841501E+05	-0.1710424092E+04	-0.4460757450E+04
	0.1319944500E+05	-0.1727266990E+04	-0.4419793935E+04
	0.1187047499E+05	-0.1741234326E+04	-0.4381705982E+04
	0.1466432167E+05	-0.5760216926E+03	-0.2792014305E+04
	0.1324452500E+05	-0.1041549996E+04	-0.2845354534E+04
	0.1182472833E+05	-0.1506961166E+04	-0.2898811897E+04
	0.1442562674E+05	-0.2706687404E+04	-0.6300758088E+04
	0.1318426366E+05	-0.2344151537E+04	-0.6092964442E+04
0.1194290058E+05	-0.1952741354E+04	-0.5914045120E+04	
0.1456074181E+05	-0.1742416294E+04	-0.4461092052E+04	
0.1322915301E+05	-0.1756794755E+04	-0.4419974178E+04	
0.1189756421E+05	-0.1768247870E+04	-0.4381781659E+04	
0.1469587850E+05	-0.6070073269E+03	-0.2792585497E+04	
0.1327406150E+05	-0.1070597401E+04	-0.2845843633E+04	
0.1185224453E+05	-0.1534081313E+04	-0.2899207950E+04	
22	0.2508279887E+05	0.2465284613E+05	-0.3413988964E+02
	0.1505517777E+05	0.1479795371E+05	-0.5825999679E+02
	0.5027877203E+04	0.4943180649E+04	-0.8281999205E+02
	0.2499070291E+05	0.2469142225E+05	-0.3118830322E+02
	0.1499794230E+05	0.1481921860E+05	-0.5829052016E+02
	0.5005606519E+04	0.4947511003E+04	-0.8631362458E+02
	0.2490124531E+05	0.2472738669E+05	-0.2826339555E+02
	0.1494252816E+05	0.1483873324E+05	-0.5839212988E+02
	0.4984277558E+04	0.4951209343E+04	-0.9011696561E+02
	0.2491182128E+05	0.2482381769E+05	-0.3413386067E+02
	0.1495187037E+05	0.1490125033E+05	-0.5824921175E+02
	0.4991919456E+04	0.4979104104E+04	-0.8278570007E+02
	0.2488384364E+05	0.2479827957E+05	-0.3118635798E+02
	0.1493395077E+05	0.1488320628E+05	-0.5828667330E+02
	0.4984057901E+04	0.4969046225E+04	-0.8630022916E+02
	0.2485586600E+05	0.2477276587E+05	-0.2826327195E+02
	0.1491603117E+05	0.1486522978E+05	-0.5839168308E+02
	0.4976196346E+04	0.4959288217E+04	-0.9011462773E+02
	0.2508279887E+05	0.2465284613E+05	-0.3413988964E+02
	0.1505517777E+05	0.1479795371E+05	-0.5825999679E+02
0.5027877204E+04	0.4943180648E+04	-0.8281999205E+02	
0.2499070291E+05	0.2469142225E+05	-0.3118830322E+02	
0.1499794230E+05	0.1481921860E+05	-0.5829052016E+02	
0.5005606520E+04	0.4947511003E+04	-0.8631362458E+02	
0.2490124531E+05	0.2472738669E+05	-0.2826339555E+02	
0.1494252816E+05	0.1483873324E+05	-0.5839212989E+02	
0.4984277559E+04	0.4951209342E+04	-0.9011696561E+02	
23	0.2484211395E+05	0.2466324975E+05	-0.2368934646E+02
	0.1490962674E+05	0.1480452446E+05	-0.5573666329E+02
	0.4978371555E+04	0.4948101741E+04	-0.9131857903E+02
	0.2473309683E+05	0.2449954298E+05	-0.3728354558E+02
	0.1484244965E+05	0.1470430498E+05	-0.6728639193E+02
	0.4952965442E+04	0.4913926801E+04	-0.1033120264E+03
	0.2462788396E+05	0.2433214578E+05	-0.5099156770E+02
	0.1477776783E+05	0.1460186694E+05	-0.7911283367E+02
	0.4928862411E+04	0.4879562845E+04	-0.1164195397E+03
	0.2480348022E+05	0.2470188304E+05	-0.2368891784E+02

ELEMENT	PRC. STRESS I	PRC. STRESS II	PRC. STRESS III
23	0.1488616386E+05 0.4968847490E+04 0.2470286952E+05 0.1482433842E+05 0.4945807320E+04 0.2460225882E+05 0.1476251299E+05 0.4922767150E+04 0.2484211395E+05 0.1490962674E+05 0.4978371556E+04 0.2473309683E+05 0.1484244965E+05 0.4952965443E+04 0.2462788396E+05 0.1477776783E+05 0.4928862411E+04	0.1482798599E+05 0.4957619307E+04 0.2452976907E+05 0.1472241288E+05 0.4921070209E+04 0.2435776851E+05 0.1461711563E+05 0.4885631950E+04 0.2466324975E+05 0.1480452446E+05 0.4948101741E+04 0.2449954298E+05 0.1470430498E+05 0.4913926800E+04 0.2433214578E+05 0.1460186694E+05 0.4879562845E+04	-0.5573531664E+02 -0.9131207970E+02 -0.3728233009E+02 -0.6728306891E+02 -0.1032973126E+03 -0.5098916924E+02 -0.7910667023E+02 -0.1163933835E+03 -0.2368934605E+02 -0.5573666304E+02 -0.9131857895E+02 -0.3728354534E+02 -0.6728639178E+02 -0.1033120263E+03 -0.5099156761E+02 -0.7911283362E+02 -0.1164195397E+03
24	0.2441010870E+05 0.1464912866E+05 0.4889272101E+04 0.2399076231E+05 0.1439800487E+05 0.4805520179E+04 0.2357879824E+05 0.1415139004E+05 0.4724054777E+04 0.2440104009E+05 0.1464360011E+05 0.4886160135E+04 0.2398987073E+05 0.1439745205E+05 0.4805033372E+04 0.2357870138E+05 0.1415130399E+05 0.4723906609E+04 0.2441010870E+05 0.1464912866E+05 0.4889272101E+04 0.2399076231E+05 0.1439800487E+05 0.4805520178E+04 0.2357879824E+05 0.1415139004E+05 0.4724054776E+04	0.2401311572E+05 0.1441708692E+05 0.4837748228E+04 0.2328327303E+05 0.1398247878E+05 0.4712102741E+04 0.2254671492E+05 0.1354501490E+05 0.4590655165E+04 0.2402218008E+05 0.1442260390E+05 0.4840809530E+04 0.2328415668E+05 0.1398301038E+05 0.4712498306E+04 0.2254679857E+05 0.1354506599E+05 0.4590655677E+04 0.2401311572E+05 0.1441708692E+05 0.4837748227E+04 0.2328327303E+05 0.1398247878E+05 0.4712102741E+04 0.2254671492E+05 0.1354501490E+05 0.4590655165E+04	-0.2839895886E+02 -0.6561076252E+02 -0.1206361524E+03 -0.5694512397E+02 -0.8349234818E+02 -0.1407305176E+03 -0.8615819253E+02 -0.1030271385E+03 -0.1673093141E+03 -0.2839470920E+02 -0.6559919386E+02 -0.1205854883E+03 -0.5693719198E+02 -0.8347112675E+02 -0.1406392764E+03 -0.8614497453E+02 -0.1029921789E+03 -0.1671616588E+03 -0.2839895840E+02 -0.6561076224E+02 -0.1206361523E+03 -0.5694512369E+02 -0.8349234801E+02 -0.1407305175E+03 -0.8615819244E+02 -0.1030271384E+03 -0.1673093141E+03
25	0.2292751924E+05 0.1376366048E+05 0.4599814916E+04 0.2179414230E+05 0.1308371871E+05 0.4373298066E+04 0.2066104698E+05 0.1240394335E+05 0.4146856756E+04 0.2292604578E+05 0.1376274052E+05 0.4599435253E+04 0.2178968886E+05 0.1308099645E+05 0.4372304048E+04 0.2065333195E+05 0.1239925239E+05 0.4145172844E+04 0.2292751924E+05 0.1376366048E+05 0.4599814916E+04 0.2179414230E+05 0.1308371871E+05 0.4373298066E+04 0.2066104698E+05	0.2141037998E+05 0.1287896188E+05 0.4426344557E+04 0.1932287637E+05 0.1164022189E+05 0.4084403991E+04 0.1723858877E+05 0.1041014672E+05 0.3770505684E+04 0.2141183144E+05 0.1287982278E+05 0.4426478378E+04 0.1932728902E+05 0.1164283720E+05 0.4084977668E+04 0.1724623223E+05 0.1041465340E+05 0.3771518759E+04 0.2141037998E+05 0.1287896188E+05 0.4426344557E+04 0.1932287637E+05 0.1164022189E+05 0.4084403991E+04 0.1723858877E+05	-0.1553513647E+02 -0.6459255571E+02 -0.1924639459E+03 -0.4598253953E+02 -0.9603747343E+02 -0.2729319324E+03 -0.7992758619E+02 -0.1363136247E+03 -0.3815177165E+03 -0.1551313886E+02 -0.6453348878E+02 -0.1922181053E+03 -0.4594175997E+02 -0.9593053411E+02 -0.2725115918E+03 -0.7985600687E+02 -0.1361293483E+03 -0.3808468799E+03 -0.1553513740E+02 -0.6459255848E+02 -0.1924639504E+03 -0.4598254008E+02 -0.9603747509E+02 -0.2729319350E+03 -0.7992758638E+02

ELEMENT	PRC. STRESS I	PRC. STRESS II	PRC. STRESS III
25	0.1240394335E+05 0.4146856756E+04	0.1041014672E+05 0.3770505684E+04	-0.1363136253E+03 -0.3815177173E+03
26	0.1929419997E+05 0.1158683916E+05 0.3879499876E+04 0.1754879937E+05 0.1053645218E+05 0.3524124851E+04 0.1580340420E+05 0.9486069143E+04 0.3168756209E+04 0.1928399647E+05 0.1158066926E+05 0.3877342057E+04 0.1753576825E+05 0.1052858466E+05 0.3521401064E+04 0.1578754004E+05 0.9476500057E+04 0.3165460070E+04 0.1929419997E+05 0.1158683916E+05 0.3879499876E+04 0.1754879937E+05 0.1053645218E+05 0.3524124851E+04 0.1580340420E+05 0.9486069143E+04 0.3168756209E+04	0.1473241744E+05 0.8951269048E+04 0.3441824434E+04 0.1152202173E+05 0.7079563483E+04 0.3003633986E+04 0.8339143714E+04 0.5268982284E+04 0.2634596440E+04 0.1474249696E+05 0.8957121397E+04 0.3442956856E+04 0.1153481308E+05 0.7086837987E+04 0.3004817903E+04 0.8354489177E+04 0.5277362823E+04 0.2635699940E+04 0.1473241744E+05 0.8951269048E+04 0.3441824434E+04 0.1152202173E+05 0.7079563483E+04 0.3003633986E+04 0.8339143714E+04 0.5268982284E+04 0.2634596440E+04	-0.5259106823E+02 -0.1530642584E+03 -0.5252627628E+03 -0.8130650421E+02 -0.2375361264E+03 -0.7603143503E+03 -0.1375450853E+03 -0.3831362997E+03 -0.1064525223E+04 -0.5246707338E+02 -0.1527467112E+03 -0.5242373655E+03 -0.8106674510E+02 -0.2369431084E+03 -0.7587744790E+03 -0.1370263935E+03 -0.3819477529E+03 -0.1062332583E+04 -0.5259106823E+02 -0.1530642584E+03 -0.5252627628E+03 -0.8130650421E+02 -0.2375361264E+03 -0.7603143503E+03 -0.1375450853E+03 -0.3831362997E+03 -0.1064525223E+04
27	0.1452452363E+05 0.8725564043E+04 0.2926626940E+04 0.1380793141E+05 0.8293765633E+04 0.2779615460E+04 0.1309134827E+05 0.7861972976E+04 0.2632608136E+04 0.1450660837E+05 0.8714788354E+04 0.2922968336E+04 0.1378937982E+05 0.8282589375E+04 0.2775798931E+04 0.1307215127E+05 0.7850390396E+04 0.2628629526E+04 0.1452452363E+05 0.8725564043E+04 0.2926626940E+04 0.1380793141E+05 0.8293765633E+04 0.2779615460E+04 0.1309134827E+05 0.7861972976E+04 0.2632608136E+04	0.5964526217E+04 0.3992962123E+04 0.2437978831E+04 0.4704800939E+04 0.3320298805E+04 0.2298318850E+04 0.3493218879E+04 0.2702458259E+04 0.2172319995E+04 0.5981397585E+04 0.4001633204E+04 0.2438911537E+04 0.4721740167E+04 0.3328598976E+04 0.2299123724E+04 0.3509687859E+04 0.2710062653E+04 0.2172994804E+04 0.5964526217E+04 0.3992962123E+04 0.2437978831E+04 0.4704800939E+04 0.3320298805E+04 0.2298318850E+04 0.3493218879E+04 0.2702458259E+04 0.2172319995E+04	-0.2707843753E+03 -0.5845608717E+03 -0.1314940657E+04 -0.3389440680E+03 -0.7154248435E+03 -0.1454443405E+04 -0.4552560583E+03 -0.9011173395E+03 -0.1607611435E+04 -0.2697404830E+03 -0.5824562636E+03 -0.1312214758E+04 -0.3373317018E+03 -0.7125487558E+03 -0.1451431749E+04 -0.4525280310E+03 -0.8971391538E+03 -0.1604307633E+04 -0.2707843753E+03 -0.5845608717E+03 -0.1314940657E+04 -0.3389440680E+03 -0.7154248435E+03 -0.1454443405E+04 -0.4552560583E+03 -0.9011173395E+03 -0.1607611435E+04
28	0.1254209506E+05 0.7507280001E+04 0.2472484378E+04 0.1213615538E+05 0.7231463374E+04 0.2326789994E+04 0.1173021570E+05 0.6955646747E+04 0.2181095667E+04 0.1252213377E+05 0.7495161230E+04 0.2468188691E+04	0.2605299757E+04 0.2230875625E+04 0.2011850553E+04 0.2046332945E+04 0.1925495458E+04 0.1863677062E+04 0.1562814918E+04 0.1636525653E+04 0.1715847885E+04 0.2621081701E+04 0.2237971980E+04 0.2012566648E+04	-0.5856596472E+03 -0.1140852177E+04 -0.1851463199E+04 -0.8273429477E+03 -0.1444478827E+04 -0.2120652423E+04 -0.1144475036E+04 -0.1764515839E+04 -0.2390186018E+04 -0.5814803052E+03 -0.1135829761E+04 -0.1847883607E+04

ELEMENT	PRC. STRESS I	PRC. STRESS II	PRC. STRESS III
28	0.1211554356E+05	0.2060744136E+04	-0.8211423163E+03
	0.7218990597E+04	0.1932159137E+04	-0.1438669729E+04
	0.2322437638E+04	0.1864398673E+04	-0.2117021677E+04
	0.1170895334E+05	0.1575151173E+04	-0.1135548930E+04
	0.6942819964E+04	0.1642721378E+04	-0.1757884782E+04
	0.2176686585E+04	0.1716574364E+04	-0.2386503414E+04
	0.1254209506E+05	0.2605299757E+04	-0.5856596472E+03
	0.7507280002E+04	0.2230875625E+04	-0.1140852177E+04
	0.2472484378E+04	0.2011850553E+04	-0.1851463199E+04
	0.1213615538E+05	0.2046332945E+04	-0.8273429477E+03
	0.7231463374E+04	0.1925495458E+04	-0.1444478827E+04
	0.2326789994E+04	0.1863677062E+04	-0.2120652423E+04
	0.1173021570E+05	0.1562814918E+04	-0.1144475036E+04
	0.6955646747E+04	0.1636525653E+04	-0.1764515839E+04
	0.2181095667E+04	0.1715847885E+04	-0.2390186018E+04
	29	0.1101199424E+05	0.9110795832E+03
0.6510580206E+04		0.1161429290E+04	-0.2694291663E+04
0.2009234648E+04		0.1422839707E+04	-0.2661013313E+04
0.1067869342E+05		0.7637359222E+03	-0.3508941947E+04
0.6281765234E+04		0.9005620431E+03	-0.3105254240E+04
0.1884895144E+04		0.1040777200E+04	-0.2705013667E+04
0.1034539281E+05		0.7246221667E+03	-0.4387414806E+04
0.6052950514E+04		0.7296554663E+03	-0.3606177739E+04
0.1760564467E+04		0.7420998689E+03	-0.2832408024E+04
0.1099057742E+05		0.9208539276E+03	-0.2727056718E+04
0.6498225509E+04		0.1166790173E+04	-0.2687297848E+04
0.2005873603E+04		0.1423134412E+04	-0.2657946973E+04
0.1065815476E+05		0.7755806054E+03	-0.3500247971E+04
0.6270064225E+04		0.9069211800E+03	-0.3099912368E+04
0.1881973686E+04		0.1041398947E+04	-0.2702713957E+04
0.1032573211E+05		0.7375229394E+03	-0.4380654880E+04
0.6041902941E+04		0.7367108425E+03	-0.3602185542E+04
0.1758073770E+04		0.7430260882E+03	-0.2830843546E+04
0.1101199424E+05		0.9110795832E+03	-0.2738699197E+04
0.6510580206E+04		0.1161429290E+04	-0.2694291663E+04
0.2009234648E+04		0.1422839707E+04	-0.2661013313E+04
0.1067869342E+05		0.7637359222E+03	-0.3508941947E+04
0.6281765234E+04		0.9005620431E+03	-0.3105254240E+04
0.1884895144E+04		0.1040777200E+04	-0.2705013667E+04
0.1034539281E+05		0.7246221667E+03	-0.4387414806E+04
0.6052950514E+04		0.7296554663E+03	-0.3606177739E+04
0.1760564467E+04		0.7420998689E+03	-0.2832408024E+04
30		0.1002136341E+05	-0.7650399467E+03
	0.5795312620E+04	-0.6324407432E+03	-0.2704639288E+04
	0.1569261912E+04	-0.4084248650E+03	-0.2264995170E+04
	0.9922467483E+04	-0.8930135455E+03	-0.1998063523E+04
	0.5763750475E+04	-0.7268283946E+03	-0.1834303103E+04
	0.1605033616E+04	-0.5386817879E+03	-0.1692504288E+04
	0.9823584453E+04	-0.7089429789E+03	-0.1072483944E+04
	0.5732196025E+04	-0.7974826388E+03	-0.9877080203E+03
	0.1640807686E+04	-0.6520562715E+03	-0.1136898212E+04
	0.1000060027E+05	-0.7451717625E+03	-0.3234805212E+04
	0.5783014092E+04	-0.6202097813E+03	-0.2704571722E+04
	0.1565427909E+04	-0.4046666013E+03	-0.2264919431E+04
	0.9901047846E+04	-0.8720206829E+03	-0.1997636748E+04
	0.5750903475E+04	-0.7140009852E+03	-0.1834283512E+04
	0.1600759104E+04	-0.5344282588E+03	-0.1692483305E+04
	0.9801495417E+04	-0.7027518166E+03	-0.1056586071E+04
	0.5718792858E+04	-0.7852727737E+03	-0.9865147183E+03
	0.1636090299E+04	-0.6474094552E+03	-0.1136827641E+04
	0.1002136341E+05	-0.7650399467E+03	-0.3235700158E+04
	0.5795312620E+04	-0.6324407432E+03	-0.2704639288E+04
	0.1569261912E+04	-0.4084248650E+03	-0.2264995170E+04
	0.9922467483E+04	-0.8930135455E+03	-0.1998063523E+04
	0.5763750475E+04	-0.7268283946E+03	-0.1834303103E+04
	0.1605033616E+04	-0.5386817879E+03	-0.1692504288E+04
	0.9823584453E+04	-0.7089429789E+03	-0.1072483944E+04
	0.5732196025E+04	-0.7974826388E+03	-0.9877080203E+03
	0.1640807686E+04	-0.6520562715E+03	-0.1136898212E+04

ELEMENT	PRC. STRESS I	PRC. STRESS II	PRC. STRESS III
32	-0.2817373960E+03 -0.3090717205E+03 -0.3359733324E+03 -0.2682364681E+03 -0.2975449995E+03 -0.3259724452E+03 -0.2544981610E+03 -0.2859806605E+03 -0.3159639958E+03 -0.2817635644E+03 -0.3090790850E+03 -0.3359770855E+03 -0.2682468762E+03 -0.2975474685E+03 -0.3259734551E+03 -0.2545001089E+03 -0.2859808634E+03 -0.3159640023E+03 -0.2817373960E+03 -0.3090717205E+03 -0.3359733324E+03 -0.2682364681E+03 -0.2975449995E+03 -0.3259724452E+03 -0.2544981610E+03 -0.2859806605E+03 -0.3159639958E+03	-0.6911368658E+04 -0.2064286135E+05 -0.3437450770E+05 -0.6920242886E+04 -0.2066998123E+05 -0.3442022519E+05 -0.6929023551E+04 -0.2069509939E+05 -0.3446221026E+05 -0.6954004571E+04 -0.2077804542E+05 -0.3460250378E+05 -0.6947598884E+04 -0.2075458613E+05 -0.3456244798E+05 -0.6941423276E+04 -0.2073116183E+05 -0.3452239800E+05 -0.6911368659E+04 -0.2064286135E+05 -0.3437450770E+05 -0.6920242887E+04 -0.2066998123E+05 -0.3442022519E+05 -0.6929023551E+04 -0.2069509939E+05 -0.3446221026E+05	-0.7028640681E+04 -0.2100048197E+05 -0.3497260231E+05 -0.7001112812E+04 -0.2091938926E+05 -0.3483804116E+05 -0.6973915885E+04 -0.2084033588E+05 -0.3470722000E+05 -0.6985978600E+04 -0.2086529054E+05 -0.3474460247E+05 -0.6973746406E+04 -0.2083478189E+05 -0.3469581736E+05 -0.6961514211E+04 -0.2080427323E+05 -0.3464703226E+05 -0.7028640680E+04 -0.2100048197E+05 -0.3497260231E+05 -0.7001112811E+04 -0.2091938926E+05 -0.3483804116E+05 -0.6973915884E+04 -0.2084033588E+05 -0.3470722000E+05
33	-0.2408990686E+03 -0.2832954036E+03 -0.3225973056E+03 -0.2293884821E+03 -0.2682783627E+03 -0.3018433527E+03 -0.2169706926E+03 -0.2530933178E+03 -0.2810452512E+03 -0.2409037977E+03 -0.2832958821E+03 -0.3225973178E+03 -0.2293994574E+03 -0.2682798142E+03 -0.3018435129E+03 -0.2169904388E+03 -0.2530962618E+03 -0.2810457255E+03 -0.2408990686E+03 -0.2832954036E+03 -0.3225973056E+03 -0.2293884821E+03 -0.2682783627E+03 -0.3018433527E+03 -0.2169706926E+03 -0.2530933178E+03 -0.2810452512E+03	-0.6903656805E+04 -0.2064347194E+05 -0.3438559926E+05 -0.6861237595E+04 -0.2050292599E+05 -0.3414906670E+05 -0.6818952178E+04 -0.2035905522E+05 -0.3390629719E+05 -0.6913734241E+04 -0.2067556308E+05 -0.3444048257E+05 -0.6869789797E+04 -0.2052750656E+05 -0.3419053998E+05 -0.6826750031E+04 -0.2037961752E+05 -0.3394064137E+05 -0.6903656806E+04 -0.2064347194E+05 -0.3438559926E+05 -0.6861237598E+04 -0.2050292599E+05 -0.3414906670E+05 -0.6818952182E+04 -0.2035905522E+05 -0.3390629719E+05	-0.6950263568E+04 -0.2079008317E+05 -0.3463068503E+05 -0.6919835173E+04 -0.2069648926E+05 -0.3447401592E+05 -0.6890180189E+04 -0.2060638817E+05 -0.3432362792E+05 -0.6940181403E+04 -0.2075799155E+05 -0.3457580170E+05 -0.6911271998E+04 -0.2067190724E+05 -0.3443254248E+05 -0.6882362592E+04 -0.2058582293E+05 -0.3428928327E+05 -0.6950263568E+04 -0.2079008317E+05 -0.3463068503E+05 -0.6919835174E+04 -0.2069648926E+05 -0.3447401592E+05 -0.6890180190E+04 -0.2060638817E+05 -0.3432362792E+05
34	-0.2140643237E+03 -0.2736848998E+03 -0.3177661289E+03 -0.2011185927E+03 -0.2533064344E+03 -0.2775945246E+03 -0.1825486958E+03 -0.2320901297E+03 -0.2372977799E+03 -0.2141018051E+03 -0.2736901382E+03 -0.3177668187E+03 -0.2011888534E+03 -0.2533163616E+03 -0.2775958627E+03	-0.6735492292E+04 -0.2009740977E+05 -0.3347422218E+05 -0.6556442869E+04 -0.1949269659E+05 -0.3245665616E+05 -0.6380810145E+04 -0.1888277579E+05 -0.3142901613E+05 -0.6738381198E+04 -0.2010477983E+05 -0.3348669012E+05 -0.6556792340E+04 -0.1949339853E+05 -0.3245785273E+05	-0.6828150173E+04 -0.2042726561E+05 -0.3402702547E+05 -0.6716224873E+04 -0.2007995899E+05 -0.3344388702E+05 -0.6606507040E+04 -0.1973869784E+05 -0.3287094772E+05 -0.6825223785E+04 -0.2041989031E+05 -0.3401455684E+05 -0.6715805142E+04 -0.2007924713E+05 -0.3344268911E+05

ELEMENT	PRC. STRESS I	PRC. STRESS II	PRC. STRESS III
34	-0.1826656208E+03 -0.2321068228E+03 -0.2373000630E+03 -0.2140643237E+03 -0.2736848998E+03 -0.3177661289E+03 -0.2011185927E+03 -0.2533064344E+03 -0.2775945246E+03 -0.1825486958E+03 -0.2320901297E+03 -0.2372977799E+03	-0.6380813763E+04 -0.1888285300E+05 -0.3142914019E+05 -0.6735492292E+04 -0.2009740977E+05 -0.3347422218E+05 -0.6556442869E+04 -0.1949269659E+05 -0.3245665616E+05 -0.6380810145E+04 -0.1888277579E+05 -0.3142901613E+05	-0.6606386498E+04 -0.1973860394E+05 -0.3287082138E+05 -0.6828150173E+04 -0.2042726561E+05 -0.3402702547E+05 -0.6716224873E+04 -0.2007995899E+05 -0.3344388702E+05 -0.6606507040E+04 -0.1973869784E+05 -0.3287094772E+05
35	-0.1681274629E+03 -0.2844236257E+03 -0.3304297864E+03 -0.9937659848E+02 -0.2597797583E+03 -0.3009544707E+03 -0.3830244981E+01 -0.2307136726E+03 -0.2708813296E+03 -0.1683161811E+03 -0.2844518682E+03 -0.3304340808E+03 -0.9971650216E+02 -0.2598320945E+03 -0.3009624981E+03 -0.4400868477E+01 -0.2308055125E+03 -0.2708954425E+03 -0.1681274629E+03 -0.2844236257E+03 -0.3304297864E+03 -0.9937659848E+02 -0.2597797583E+03 -0.3009544707E+03 -0.3830244978E+01 -0.2307136726E+03 -0.2708813296E+03	-0.6087194806E+04 -0.1791856922E+05 -0.2982022007E+05 -0.5582354718E+04 -0.1619262889E+05 -0.2692213127E+05 -0.5104211855E+04 -0.1447087152E+05 -0.2402424237E+05 -0.6087453384E+04 -0.1791976730E+05 -0.2982223469E+05 -0.5583269994E+04 -0.1619626912E+05 -0.2692825343E+05 -0.5105802558E+04 -0.1447717774E+05 -0.2403486763E+05 -0.6087194806E+04 -0.1791856922E+05 -0.2982022007E+05 -0.5582354718E+04 -0.1619262889E+05 -0.2692213127E+05 -0.5104211855E+04 -0.1447087152E+05 -0.2402424237E+05	-0.6422178051E+04 -0.1918933882E+05 -0.3195651315E+05 -0.6110898335E+04 -0.1824770050E+05 -0.3038450289E+05 -0.5799716884E+04 -0.1730630143E+05 -0.2881289055E+05 -0.6421730754E+04 -0.1918811249E+05 -0.3195449424E+05 -0.6109643156E+04 -0.1824400793E+05 -0.3037837270E+05 -0.5797555558E+04 -0.1729990337E+05 -0.2880225117E+05 -0.6422178051E+04 -0.1918933882E+05 -0.3195651315E+05 -0.6110898335E+04 -0.1824770050E+05 -0.3038450289E+05 -0.5799716884E+04 -0.1730630143E+05 -0.2881289055E+05
36	0.1318082338E+03 -0.2239855709E+03 -0.3016694180E+03 0.3441410967E+03 -0.1797456297E+03 -0.2934976851E+03 0.6462167111E+03 -0.1002984010E+03 -0.2791149000E+03 0.1309080100E+03 -0.2241459674E+03 -0.3016954773E+03 0.3426857137E+03 -0.1800550237E+03 -0.2935498977E+03 0.6439535417E+03 -0.1009641781E+03 -0.2792325542E+03 0.1318082338E+03 -0.2239855709E+03 -0.3016694180E+03 0.3441410967E+03 -0.1797456297E+03 -0.2934976851E+03 0.6462167111E+03 -0.1002984010E+03 -0.2791149000E+03	-0.4504055117E+04 -0.1234135030E+05 -0.2045675257E+05 -0.3820039677E+04 -0.9692046435E+04 -0.1597418479E+05 -0.3225766182E+04 -0.7077947050E+04 -0.1149782265E+05 -0.4505872685E+04 -0.1234954517E+05 -0.2047072213E+05 -0.3822092282E+04 -0.9702446156E+04 -0.1599204589E+05 -0.3227802003E+04 -0.7090347042E+04 -0.1151954142E+05 -0.4504055117E+04 -0.1234135030E+05 -0.2045675257E+05 -0.3820039677E+04 -0.9692046435E+04 -0.1597418479E+05 -0.3225766182E+04 -0.7077947050E+04 -0.1149782265E+05	-0.5407257618E+04 -0.1614758520E+05 -0.2688791566E+05 -0.4922567889E+04 -0.1469251909E+05 -0.2446247336E+05 -0.4437878966E+04 -0.1323745577E+05 -0.2203703647E+05 -0.5404539827E+04 -0.1613922993E+05 -0.2687392004E+05 -0.4919059901E+04 -0.1468180997E+05 -0.2444456004E+05 -0.4433579976E+04 -0.1322439001E+05 -0.2201520004E+05 -0.5407257618E+04 -0.1614758520E+05 -0.2688791566E+05 -0.4922567889E+04 -0.1469251909E+05 -0.2446247336E+05 -0.4437878966E+04 -0.1323745577E+05 -0.2203703647E+05
37	0.1036546827E+04 0.7625261110E+02	-0.2820866229E+04 -0.5081720246E+04	-0.4057168902E+04 -0.1214903715E+05

ELEMENT	PRC. STRESS I	PRC. STRESS II	PRC. STRESS III
37	-0.1860545031E+03 0.1227132926E+04 0.1832979616E+03 -0.1924604472E+03 0.1432191201E+04 0.3518844294E+03 -0.1785681051E+03 0.1033486630E+04 0.7492786829E+02 -0.1862658505E+03 0.1223740186E+04 0.1812420798E+03 -0.1928530734E+03 0.1428458803E+04 0.3485097551E+03 -0.1794323678E+03 0.1036546827E+04 0.7625261110E+02 -0.1860545031E+03 0.1227132926E+04 0.1832979616E+03 -0.1924604472E+03 0.1432191201E+04 0.3518844294E+03 -0.1785681051E+03	-0.8040558808E+04 -0.2621231472E+04 -0.4078955628E+04 -0.6204754601E+04 -0.2436066517E+04 -0.3137725475E+04 -0.4389237213E+04 -0.2822557189E+04 -0.5095060645E+04 -0.8064929143E+04 -0.2622738961E+04 -0.4092096712E+04 -0.6229857417E+04 -0.2437385794E+04 -0.3150086244E+04 -0.4414793619E+04 -0.2820866229E+04 -0.5081720246E+04 -0.8040558808E+04 -0.2621231472E+04 -0.4078955628E+04 -0.6204754601E+04 -0.2436066517E+04 -0.3137725475E+04 -0.4389237213E+04	-0.2024090795E+05 -0.3852660342E+04 -0.1154999306E+05 -0.1924732751E+05 -0.3648154157E+04 -0.1095095562E+05 -0.1825375854E+05 -0.4052417745E+04 -0.1213437201E+05 -0.2021632627E+05 -0.3847760113E+04 -0.1153479609E+05 -0.1922183207E+05 -0.3643102482E+04 -0.1093522018E+05 -0.1822733787E+05 -0.4057168902E+04 -0.1214903715E+05 -0.2024090795E+05 -0.3852660342E+04 -0.1154999306E+05 -0.1924732751E+05 -0.3648154157E+04 -0.1095095562E+05 -0.1825375854E+05
38	0.1570288146E+04 0.5735312949E+03 -0.6950018965E+02 0.1589045924E+04 0.6971054917E+03 0.1052705016E+01 0.1622901550E+04 0.8964696136E+03 0.2037892333E+03 0.1566260354E+04 0.5682022081E+03 -0.7167057550E+02 0.1584665570E+04 0.6898677113E+03 -0.3371690284E+01 0.1618157698E+04 0.8868633996E+03 0.1929509748E+03 0.1570288146E+04 0.5735312949E+03 -0.6950018965E+02 0.1589045924E+04 0.6971054917E+03 0.1052705016E+01 0.1622901550E+04 0.8964696136E+03 0.2037892333E+03	-0.2368036622E+04 -0.2455179647E+04 -0.2896042003E+04 -0.2314932427E+04 -0.2056990030E+04 -0.1994929372E+04 -0.2276926001E+04 -0.1734590331E+04 -0.1226000369E+04 -0.2369070088E+04 -0.2466058901E+04 -0.2921233076E+04 -0.2315862816E+04 -0.2066522921E+04 -0.2018741483E+04 -0.2277742458E+04 -0.1742317127E+04 -0.1244273670E+04 -0.2368036622E+04 -0.2455179647E+04 -0.2896042003E+04 -0.2314932427E+04 -0.2056990030E+04 -0.1994929372E+04 -0.2276926001E+04 -0.1734590331E+04 -0.1226000369E+04	-0.3514212175E+04 -0.1047744625E+05 -0.1744068635E+05 -0.3438631614E+04 -0.1017366121E+05 -0.1690869672E+05 -0.3363051132E+04 -0.9869876190E+04 -0.1637670709E+05 -0.3509150917E+04 -0.1046123791E+05 -0.1741332489E+05 -0.3433320871E+04 -0.1015689054E+05 -0.1688046021E+05 -0.3357490824E+04 -0.9852543179E+04 -0.1634759553E+05 -0.3514212175E+04 -0.1047744625E+05 -0.1744068635E+05 -0.3438631614E+04 -0.1017366121E+05 -0.1690869672E+05 -0.3363051132E+04 -0.9869876190E+04 -0.1637670709E+05
39	0.1674020716E+04 0.1199406251E+04 0.7374066743E+03 0.1446734021E+04 0.1162442741E+04 0.9068164876E+03 0.1261572843E+04 0.1171518222E+04 0.1116987170E+04 0.1669178802E+04 0.1187452208E+04 0.7162230537E+03 0.1441667827E+04 0.1149062061E+04 0.8823652101E+03 0.1256153076E+04 0.1156533128E+04	-0.2003021208E+04 -0.1274567028E+04 -0.5586825373E+03 -0.1692642418E+04 -0.1048931806E+04 -0.4338513956E+03 -0.1424385657E+04 -0.8693355643E+03 -0.3497811220E+03 -0.2003587289E+04 -0.1280024616E+04 -0.5669593818E+03 -0.1693264152E+04 -0.1053180401E+04 -0.4390055650E+03 -0.1424937239E+04 -0.8721974003E+03	-0.3235629926E+04 -0.9545792143E+04 -0.1585599956E+05 -0.3181937168E+04 -0.9407304838E+04 -0.1563270733E+05 -0.3128247897E+04 -0.9268817544E+04 -0.1540941511E+05 -0.3230221931E+04 -0.9528380512E+04 -0.1582653909E+05 -0.3176249240E+04 -0.9389675562E+04 -0.1560310189E+05 -0.3122276548E+04 -0.9250970613E+04

ELEMENT	PRC. STRESS I	PRC. STRESS II	PRC. STRESS III
39	0.1090132636E+04	-0.3526770177E+03	-0.1537966468E+05
	0.1674020716E+04	-0.2003021208E+04	-0.3235629926E+04
	0.1199406251E+04	-0.1274567028E+04	-0.9545792143E+04
	0.7374066743E+03	-0.5586825373E+03	-0.1585599956E+05
	0.1446734021E+04	-0.1692642418E+04	-0.3181937168E+04
	0.1162442741E+04	-0.1048931806E+04	-0.9407304838E+04
	0.9068164876E+03	-0.4338513956E+03	-0.1563270733E+05
	0.1261572843E+04	-0.1424385657E+04	-0.3128247897E+04
	0.1171518222E+04	-0.8693355643E+03	-0.9268817544E+04
	0.1116987170E+04	-0.3497811220E+03	-0.1540941511E+05
40	0.3619018525E+03	-0.8823406819E+03	-0.3148453692E+04
	0.6435701416E+03	-0.5315377483E+03	-0.9111628012E+04
	0.9566626424E+03	-0.2121521966E+03	-0.1507480916E+05
	0.1256762624E+03	-0.4143253825E+03	-0.2983960887E+04
	0.4027026451E+03	-0.2862727643E+03	-0.8792077523E+04
	0.6952733112E+03	-0.1737569176E+03	-0.1460020167E+05
	0.9677792056E+02	-0.1536345984E+03	-0.2819470815E+04
	0.2277184711E+03	-0.1068803904E+03	-0.8472537747E+04
	0.4505183623E+03	-0.1519776126E+03	-0.1412561259E+05
	0.3564059645E+03	-0.8827335480E+03	-0.3142564938E+04
	0.6263714370E+03	-0.5322774078E+03	-0.9093689648E+04
	0.9269423483E+03	-0.2124267065E+03	-0.1504481436E+05
	0.1204469520E+03	-0.4146022548E+03	-0.2978454704E+04
	0.3853523961E+03	-0.2864831986E+03	-0.8774516840E+04
	0.6656760453E+03	-0.1737823475E+03	-0.1457057898E+05
	0.9445856125E+02	-0.1564415834E+03	-0.2814344471E+04
	0.2120082700E+03	-0.1083639041E+03	-0.8455344032E+04
	0.4215760325E+03	-0.1523042786E+03	-0.1409634359E+05
	0.3619018525E+03	-0.8823406819E+03	-0.3148453692E+04
	0.6435701416E+03	-0.5315377483E+03	-0.9111628012E+04
	0.9566626424E+03	-0.2121521966E+03	-0.1507480916E+05
	0.1256762624E+03	-0.4143253825E+03	-0.2983960887E+04
	0.4027026451E+03	-0.2862727643E+03	-0.8792077523E+04
	0.6952733112E+03	-0.1737569176E+03	-0.1460020167E+05
	0.9677792056E+02	-0.1536345984E+03	-0.2819470815E+04
	0.2277184711E+03	-0.1068803904E+03	-0.8472537747E+04
	0.4505183623E+03	-0.1519776126E+03	-0.1412561259E+05

§ELEMENT TYPE = 68

PENTA ELEMENT OUTPUT

ELEMENT	PRC. STRESS I	PRC. STRESS II	PRC. STRESS III
1	0.4047868000E+05	0.4038264000E+05	-0.2871883000E+02
11	0.3462165000E+05	0.3462165000E+05	-0.1873956000E+02
21	0.1496160000E+05	0.1494155000E+05	-0.4550138000E+02
31	-0.7373995000E+02	-0.2046206000E+05	-0.2048384000E+05

§ELEMENT TYPE = 64

QUAD8 ELEMENT OUTPUT

ELEMENT	PRC. STRESS I	PRC. STRESS II
6	0.3240360414E+05	0.2459075257E+05
	0.3240355835E+05	0.2459079836E+05
	0.3240360414E+05	0.2459075257E+05
	0.2947038786E+05	0.1912894214E+05
	0.2947035500E+05	0.1912897500E+05
	0.2947038786E+05	0.1912894214E+05
	0.2653717670E+05	0.1366712659E+05
	0.2653715165E+05	0.1366715164E+05
	0.2653717670E+05	0.1366712659E+05

ELEMENT	PRC. STRESS I	PRC. STRESS II
7	0.2433658445E+05	0.9671127904E+04
	0.2433656501E+05	0.9671147345E+04
	0.2433658445E+05	0.9671127904E+04
	0.2311081780E+05	0.7333799204E+04
	0.2311081500E+05	0.7333802000E+04
	0.2311081780E+05	0.7333799204E+04
	0.2188506576E+05	0.4996455887E+04
	0.2188506499E+05	0.4996456655E+04
	0.2188506576E+05	0.4996455887E+04
8	0.2107414816E+05	0.3761195317E+04
	0.2107414500E+05	0.3761198473E+04
	0.2107414816E+05	0.3761195317E+04
	0.2040679811E+05	0.2452024292E+04
	0.2040679500E+05	0.2452027400E+04
	0.2040679811E+05	0.2452024292E+04
	0.1973944806E+05	0.1142853262E+04
	0.1973944500E+05	0.1142856327E+04
	0.1973944806E+05	0.1142853262E+04
42	0.4211781711E+05	0.4139398789E+05
	0.4181597667E+05	0.4169582833E+05
	0.4211781711E+05	0.4139398789E+05
	0.4178449034E+05	0.4128908466E+05
	0.4157924500E+05	0.4149433000E+05
	0.4178449034E+05	0.4128908466E+05
	0.4151319761E+05	0.4112214739E+05
	0.4146266167E+05	0.4117268333E+05
	0.4151319761E+05	0.4112214739E+05
43	0.4161813952E+05	0.4135627882E+05
	0.4150555333E+05	0.4146886500E+05
	0.4161813952E+05	0.4135627882E+05
	0.4135884529E+05	0.4095878971E+05
	0.4129888000E+05	0.4101875500E+05
	0.4135884529E+05	0.4095878971E+05
	0.4113515019E+05	0.4052570147E+05
	0.4109220667E+05	0.4056864500E+05
	0.4113515019E+05	0.4052570147E+05
44	0.4090343134E+05	0.4026249201E+05
	0.4087703167E+05	0.4028889167E+05
	0.4090343134E+05	0.4026249201E+05
	0.4018568506E+05	0.3895952494E+05
	0.4017845500E+05	0.3896675500E+05
	0.4018568506E+05	0.3895952494E+05
	0.3948186285E+05	0.3764263381E+05
	0.3947987833E+05	0.3764461833E+05
	0.3948186285E+05	0.3764263381E+05
45	0.3848862863E+05	0.3585721639E+05
	0.3848810834E+05	0.3585773668E+05
	0.3848862863E+05	0.3585721639E+05
	0.3658289172E+05	0.3231068328E+05
	0.3658286500E+05	0.3231071000E+05
	0.3658289172E+05	0.3231068328E+05
	0.3467766297E+05	0.2876364200E+05
	0.3467762166E+05	0.2876368332E+05
	0.3467766297E+05	0.2876364200E+05
49	0.1958804843E+05	0.1561804751E+04
	0.1958804500E+05	0.1561808175E+04
	0.1958804843E+05	0.1561804751E+04
	0.1898671851E+05	-0.1427850144E+03
	0.1898671500E+05	-0.1427815000E+03
	0.1898671851E+05	-0.1427850144E+03
	0.1838538860E+05	-0.1847374781E+04
	0.1838538500E+05	-0.1847371175E+04
	0.1838538860E+05	-0.1847374781E+04

ELEMENT	PRC. STRESS I	PRC. STRESS II
50	0.1778024837E+05	-0.2365726210E+04
	0.1778024833E+05	-0.2365726178E+04
	0.1778024837E+05	-0.2365726210E+04
	0.1770499743E+05	-0.1829909305E+03
	0.1770498500E+05	-0.1829785000E+03
	0.1770499743E+05	-0.1829909305E+03
	0.1762977555E+05	0.1999715295E+04
	0.1762972167E+05	0.1999769178E+04
	0.1762977555E+05	0.1999715295E+04

§ELEMENT TYPE = 75

TRIA6 ELEMENT OUTPUT

ELEMENT	PRC. STRESS I	PRC. STRESS II
41	0.4163506000E+05	0.4143901000E+05

--- CROSS REFERENCE TABLE FOR SHELL ELEMENTS ---

SHELL ELT. NO.	SOLID ELT. NO.
6	6
7	7
8	8
42	2
43	3
44	4
45	5
49	9
50	10
41	1

--- CROSS REFERENCE TABLE FOR SOLID ELEMENTS ---

SOLID ELT. NO.	SHELL ELT. NOS.
2	42
3	43
4	44
5	45
6	6
7	7
8	8
9	49
10	50
1	41

--- VOLUME AND TEMPERATURE OF EACH SOLID ELEMENT ---

ELEMENT NO.	VOLUME	AVE. TEMP.
2	0.4177E-06	0.7000E+02
3	0.2088E-05	0.7000E+02
4	0.9189E-05	0.7000E+02
5	0.2631E-04	0.7000E+02
6	0.4135E-04	0.7000E+02
7	0.1713E-04	0.7000E+02
8	0.9189E-05	0.7000E+02
9	0.4751E-05	0.7000E+02
10	0.2005E-04	0.7000E+02

--- VOLUME AND TEMPERATURE OF EACH SOLID ELEMENT ---

ELEMENT NO.	VOLUME	AVE. TEMP.
12	0.1671E-05	0.7000E+02
13	0.8354E-05	0.7000E+02
14	0.3676E-04	0.7000E+02
15	0.1053E-03	0.7000E+02
16	0.1654E-03	0.7000E+02
17	0.6850E-04	0.7000E+02
18	0.3676E-04	0.7000E+02
19	0.1900E-04	0.7000E+02
20	0.8020E-04	0.7000E+02
22	0.5325E-05	0.7000E+02
23	0.2663E-04	0.7000E+02
24	0.1172E-03	0.7000E+02
25	0.3355E-03	0.7000E+02
26	0.5272E-03	0.7000E+02
27	0.2183E-03	0.7000E+02
28	0.1172E-03	0.7000E+02
29	0.6058E-04	0.7000E+02
30	0.2556E-03	0.7000E+02
32	0.7414E-05	0.7000E+02
33	0.3707E-04	0.7000E+02
34	0.1631E-03	0.7000E+02
35	0.4671E-03	0.7000E+02
36	0.7340E-03	0.7000E+02
37	0.3040E-03	0.7000E+02
38	0.1631E-03	0.7000E+02
39	0.8433E-04	0.7000E+02
40	0.3559E-03	0.7000E+02
1	0.5221E-07	0.7000E+02
11	0.2088E-06	0.7000E+02
21	0.6657E-06	0.7000E+02
31	0.9267E-06	0.7000E+02

--- AREA AND TEMPERATURE OF EACH SHELL ELEMENT ---

ELEMENT NO.	AREA	AVE. TEMP.
6	0.2073E-01	0.7000E+02
7	0.8587E-02	0.7000E+02
8	0.4608E-02	0.7000E+02
42	0.2094E-03	0.7000E+02
43	0.1047E-02	0.7000E+02
44	0.4608E-02	0.7000E+02
45	0.1320E-01	0.7000E+02
49	0.2382E-02	0.7000E+02
50	0.1005E-01	0.7000E+02
41	0.2618E-04	0.7000E+02

```

*****
*
*           ECHO OF MATERIAL CONTROL INPUT           *
*
*
*****

```

TITLE = ALUMINA SPECIMEN DATA FOR VOLUME FLAW ANALYSIS (REF. RUFIN AND SAMOS)

300 = MATERIAL IDENTIFICATION NUMBER (MATID)

1 = CONTROL INDEX FOR VOLUME OR SURFACE FLAW ANALYSIS (ID4)
 1 : VOLUME
 2 : SURFACE

3 = CONTROL INDEX FOR EXPERIMENTAL DATA (ID1)
 1 : UNIFORM UNIAXIAL TENSILE SPECIMEN TEST DATA
 2 : FOUR-POINT BEND TEST DATA
 3 : DIRECT INPUT OF THE WEIBULL PARAMETERS, M AND SP
 (SHAPE PARAMETER AND SCALE PARAMETER)
 4 : CENSORED DATA FOR SUSPENDED ITEM ANALYSIS OF
 UNIFORM UNIAXIAL TENSILE SPECIMEN TEST DATA
 5 : CENSORED DATA FOR SUSPENDED ITEM ANALYSIS OF
 FOUR-POINT BEND TEST DATA

5 = CONTROL INDEX FOR VOLUME FRACTURE CRITERION (ID2V)
 1 : NORMAL STRESS FRACTURE CRITERION
 (SHEAR-INSENSITIVE CRACK)
 2 : MAXIMUM TENSILE STRESS CRITERION
 3 : COPLANAR STRAIN ENERGY RELEASE RATE CRITERION
 4 : WEIBULL PIA MODEL
 5 : SHETTY'S SEMI-EMPIRICAL CRITERION

2 = CONTROL INDEX FOR SHAPE OF VOLUME CRACKS (ID3V)
 1 : GRIFFITH CRACK
 2 : PENNY-SHAPED CRACK

0 = CONTROL INDEX FOR METHOD OF CALCULATING BATDORF CRACK DENSITY COEFFICIENT
 (K SUB B) FROM TEST DATA (IKBAT)
 0 : SHEAR-INSENSITIVE METHOD (MODE I FRACTURE ASSUMED)
 1 : SHEAR-SENSITIVE METHOD (FRACTURE ASSUMED TO OCCUR
 ACCORDING TO THE FRACTURE CRITERION AND CRACK
 SHAPE SELECTED BY THE ID2 AND ID3 INDICES)

0.8000 = CONSTANT FOR SHETTY'S SEMI-EMPIRICAL FRACTURE CRITERION (C)
 $(K_I/K_{IC}) + ((K_{II} \text{ OR } K_{III}) / (C * K_{IC}))^{*2} = 1$
 OBSERVED VALUES RANGE FROM .8 TO 2. (REF. D. K. SHETTY)
 NOTE: AS C APPROACHES INFINITY PREDICTED FAILURE
 PROBABILITIES APPROACH NORMAL STRESS CRITERION
 0.2500 = POISSON'S RATIO (PR)

```

*****
*
*           VOLUME FLAW PARAMETER ANALYSIS
*
*****

```

*** BATDORF MODEL --- CRACK ORIENTATION, CRACK SHAPE, AND FRACTURE CRITERION ARE CONSIDERED ***

--- TEMPERATURE DEPENDENT MATERIAL PARAMETERS FOR MATERIAL NUMBER 300

WEIBULL MODULUS (SHAPE PARAMETER), M (DIMENSIONLESS)
 NORMALIZED BATDORF CRACK DENSITY COEFFICIENT, K (DIMENSIONLESS)
 SCALE PARAMETER, SP (UNITS OF STRESS*VOLUME*(1/M))

TEMPERATURE	M	K	SP
70.0000	0.2853E+02	0.5806E+02	0.3620E+05

FRACTURE CRITERION = $(K_I/K_{IC}) + ((K_{II} \text{ OR } K_{III}) / (C * K_{IC}))^2 = 1$ WHERE C = 0.8000E+00
 CRACK SHAPE = PENNY-SHAPED CRACK

```

*****
*
*           ECHO OF MATERIAL CONTROL INPUT
*
*****

```

TITLE = ALUMINA SPECIMEN DATA FOR SURFACE FLAW ANALYSIS (REF. RUFIN AND SAMOS)

300 = MATERIAL IDENTIFICATION NUMBER (MATID)

2 = CONTROL INDEX FOR VOLUME OR SURFACE FLAW ANALYSIS (ID4)
 1 : VOLUME
 2 : SURFACE

3 = CONTROL INDEX FOR EXPERIMENTAL DATA (ID1)
 1 : UNIFORM UNIAXIAL TENSILE SPECIMEN TEST DATA
 2 : FOUR-POINT BEND TEST DATA
 3 : DIRECT INPUT OF THE WEIBULL PARAMETERS, M AND SP
 (SHAPE PARAMETER AND SCALE PARAMETER)
 4 : CENSORED DATA FOR SUSPENDED ITEM ANALYSIS OF
 UNIFORM UNIAXIAL TENSILE SPECIMEN TEST DATA
 5 : CENSORED DATA FOR SUSPENDED ITEM ANALYSIS OF
 FOUR-POINT BEND TEST DATA

5 = CONTROL INDEX FOR SURFACE FRACTURE CRITERION (ID2S)
 1 : NORMAL STRESS FRACTURE CRITERION
 (SHEAR-INSENSITIVE CRACK)
 3 : COPLANAR STRAIN ENERGY RELEASE RATE CRITERION
 4 : WEIBULL PIA MODEL
 5 : SHETTY'S SEMI-EMPIRICAL CRITERION

(12)

4 = CONTROL INDEX FOR SHAPE OF SURFACE CRACKS (ID3S)
 1 : GRIFFITH CRACK
 (ASSOCIATED WITH STRAIN ENERGY RELEASE RATE CRITERION)
 (ASSOCIATED WITH SHETTY'S SEMI-EMPIRICAL CRITERION)
 3 : GRIFFITH NOTCH
 (ASSOCIATED WITH STRAIN ENERGY RELEASE RATE CRITERION)
 (ASSOCIATED WITH SHETTY'S SEMI-EMPIRICAL CRITERION)
 4 : SEMICIRCULAR CRACK
 (ASSOCIATED WITH SHETTY'S SEMI-EMPIRICAL CRITERION)

0 = CONTROL INDEX FOR METHOD OF CALCULATING BATDORF CRACK DENSITY COEFFICIENT
 (K SUB B) FROM TEST DATA (IKBAT)
 0 : SHEAR-INSENSITIVE METHOD (MODE I FRACTURE ASSUMED)
 1 : SHEAR-SENSITIVE METHOD (FRACTURE ASSUMED TO OCCUR
 ACCORDING TO THE FRACTURE CRITERION AND CRACK
 SHAPE SELECTED BY THE ID2 AND ID3 INDICES)

0.8000 = CONSTANT FOR SHETTY'S SEMI-EMPIRICAL FRACTURE CRITERION (C)
 $(K_I/K_{IC}) + ((K_{II} \text{ OR } K_{III}) / (C * K_{IC}))^{**2} = 1$
 OBSERVED VALUES RANGE FROM .8 TO 2. (REF. D. K. SHETTY)
 NOTE: AS C APPROACHES INFINITY PREDICTED FAILURE
 PROBABILITIES APPROACH NORMAL STRESS CRITERION

0.2500 = POISSON'S RATIO (PR)

```

XXXXXXXXXXXXXXXXXXXXXXXXXXXXXXXXXXXXXXXXXXXXXXXXXXXXXXXXXXXX
X
X          SURFACE FLAW PARAMETER ANALYSIS          X
X
XXXXXXXXXXXXXXXXXXXXXXXXXXXXXXXXXXXXXXXXXXXXXXXXXXXXXXXXXXXX

```

**** BATDORF MODEL --- CRACK ORIENTATION, CRACK SHAPE, AND FRACTURE CRITERION ARE
 CONSIDERED ****

--- TEMPERATURE DEPENDENT MATERIAL PARAMETERS FOR MATERIAL NUMBER 300

WEIBULL MODULUS (SHAPE PARAMETER), M (DIMENSIONLESS)
 NORMALIZED BATDORF CRACK DENSITY COEFFICIENT, K (DIMENSIONLESS)
 SCALE PARAMETER, SP (UNITS OF STRESS*AREA**(1/M))

TEMPERATURE	M	K	SP
70.0000	0.2853E+02	0.9557E+01	0.4584E+05

FRACTURE CRITERION = $(K_I/K_{IC}) + ((K_{II} \text{ OR } K_{III}) / (C * K_{IC}))^{**2} = 1$ WHERE C = 0.8000E+00
 CRACK SHAPE = SEMICIRCULAR CRACK

 * VOLUME FLAW RELIABILITY ANALYSIS *
 *

NOTE: THE ELEMENT SURVIVAL AND FAILURE PROBABILITIES TAKE INTO ACCOUNT THE NUMBER OF SEGMENTS (NS).

--- ELEMENT CALCULATIONS ---

ELEMENT	MATID	SURVIVAL PROB.	FAILURE PROB.	RISK	RUP.	INT.	M	K	SP
2	300	0.8781D+00	0.1219D+00	0.6482D+04	0.2853D+02	0.5806D+02	0.3620D+05		
3	300	0.6002D+00	0.3998D+00	0.5094D+04	0.2853D+02	0.5806D+02	0.3620D+05		
4	300	0.4245D+00	0.5755D+00	0.1943D+04	0.2853D+02	0.5806D+02	0.3620D+05		
5	300	0.8494D+00	0.1506D+00	0.1292D+03	0.2853D+02	0.5806D+02	0.3620D+05		
6	300	0.9991D+00	0.8960D-03	0.4516D+00	0.2853D+02	0.5806D+02	0.3620D+05		
7	300	0.1000D+01	0.1209D-06	0.1470D-03	0.2853D+02	0.5806D+02	0.3620D+05		
8	300	0.1000D+01	0.1718D-08	0.3896D-05	0.2853D+02	0.5806D+02	0.3620D+05		
9	300	0.1000D+01	0.9476D-10	0.4155D-06	0.2853D+02	0.5806D+02	0.3620D+05		
10	300	0.1000D+01	0.5139D-10	0.5340D-07	0.2853D+02	0.5806D+02	0.3620D+05		
12	300	0.9764D+00	0.2361D-01	0.2979D+03	0.2853D+02	0.5806D+02	0.3620D+05		
13	300	0.9126D+00	0.8741D-01	0.2281D+03	0.2853D+02	0.5806D+02	0.3620D+05		
14	300	0.8583D+00	0.1417D+00	0.8657D+02	0.2853D+02	0.5806D+02	0.3620D+05		
15	300	0.9714D+00	0.2860D-01	0.5740D+01	0.2853D+02	0.5806D+02	0.3620D+05		
16	300	0.9998D+00	0.1589D-03	0.2002D-01	0.2853D+02	0.5806D+02	0.3620D+05		
17	300	0.1000D+01	0.2125D-07	0.6462D-05	0.2853D+02	0.5806D+02	0.3620D+05		
18	300	0.1000D+01	0.3085D-09	0.1748D-06	0.2853D+02	0.5806D+02	0.3620D+05		
19	300	0.1000D+01	0.1913D-10	0.2097D-07	0.2853D+02	0.5806D+02	0.3620D+05		
20	300	0.1000D+01	0.1018D-10	0.2645D-08	0.2853D+02	0.5806D+02	0.3620D+05		
22	300	0.1000D+01	0.5067D-06	0.1982D-02	0.2853D+02	0.5806D+02	0.3620D+05		
23	300	0.1000D+01	0.1953D-05	0.1528D-02	0.2853D+02	0.5806D+02	0.3620D+05		
24	300	0.1000D+01	0.3264D-05	0.5802D-03	0.2853D+02	0.5806D+02	0.3620D+05		
25	300	0.1000D+01	0.6209D-06	0.3855D-04	0.2853D+02	0.5806D+02	0.3620D+05		
26	300	0.1000D+01	0.3470D-08	0.1371D-06	0.2853D+02	0.5806D+02	0.3620D+05		
27	300	0.1000D+01	0.5017D-12	0.4788D-10	0.2853D+02	0.5806D+02	0.3620D+05		
28	300	0.1000D+01	0.7873D-14	0.1399D-11	0.2853D+02	0.5806D+02	0.3620D+05		
29	300	0.1000D+01	0.7458D-15	0.2565D-12	0.2853D+02	0.5806D+02	0.3620D+05		
30	300	0.1000D+01	0.2818D-15	0.2297D-13	0.2853D+02	0.5806D+02	0.3620D+05		
32	300	0.1000D+01	0.0000D+00	0.0000D+00	0.2853D+02	0.5806D+02	0.3620D+05		
33	300	0.1000D+01	0.0000D+00	0.0000D+00	0.2853D+02	0.5806D+02	0.3620D+05		
34	300	0.1000D+01	0.0000D+00	0.0000D+00	0.2853D+02	0.5806D+02	0.3620D+05		
35	300	0.1000D+01	0.0000D+00	0.0000D+00	0.2853D+02	0.5806D+02	0.3620D+05		
36	300	0.1000D+01	0.0000D+00	0.0000D+00	0.2853D+02	0.5806D+02	0.3620D+05		
37	300	0.1000D+01	0.0000D+00	0.0000D+00	0.2853D+02	0.5806D+02	0.3620D+05		
38	300	0.1000D+01	0.0000D+00	0.0000D+00	0.2853D+02	0.5806D+02	0.3620D+05		
39	300	0.1000D+01	0.0000D+00	0.0000D+00	0.2853D+02	0.5806D+02	0.3620D+05		
40	300	0.1000D+01	0.0000D+00	0.0000D+00	0.2853D+02	0.5806D+02	0.3620D+05		
1	300	0.9840D+00	0.1603D-01	0.6447D+04	0.2853D+02	0.5806D+02	0.3620D+05		
11	300	0.9992D+00	0.7763D-03	0.7749D+02	0.2853D+02	0.5806D+02	0.3620D+05		
21	300	0.1000D+01	0.9945D-13	0.3112D-08	0.2853D+02	0.5806D+02	0.3620D+05		
31	300	0.1000D+01	0.0000D+00	0.0000D+00	0.2853D+02	0.5806D+02	0.3620D+05		

SORTED MAXIMUM RISK OF RUPTURE INTENSITIES AND CORRESPONDING ELEMENT NUMBERS

ELEMENT	RISK RUP. INT.
2	0.6482D+04
1	0.6447D+04
3	0.5094D+04
4	0.1943D+04
12	0.2979D+03
13	0.2281D+03
5	0.1292D+03
14	0.8657D+02
11	0.7749D+02
15	0.5740D+01
6	0.4516D+00
16	0.2002D-01
22	0.1982D-02
23	0.1528D-02
24	0.5802D-03

FOR F.E. MODEL VOLUME --- PROBABILITY OF FAILURE = 0.8613D+00
 PROBABILITY OF SURVIVAL = 0.1387D+00

```

*****
*
* SURFACE FLAW RELIABILITY ANALYSIS *
*
*****
    
```

NOTE: THE ELEMENT SURVIVAL AND FAILURE PROBABILITIES TAKE INTO ACCOUNT THE NUMBER OF SEGMENTS (NS).

--- ELEMENT CALCULATIONS ---

ELEMENT	MATID	SURVIVAL PROB.	FAILURE PROB.	RISK RUP. INT.	M	K	SP
6	300	0.1000D+01	0.4404D-04	0.4425D-04	0.2853D+02	0.9557D+01	0.4584D+05
7	300	0.1000D+01	0.5880D-08	0.1427D-07	0.2853D+02	0.9557D+01	0.4584D+05
8	300	0.1000D+01	0.8469D-10	0.3829D-09	0.2853D+02	0.9557D+01	0.4584D+05
42	300	0.9943D+00	0.5747D-02	0.5734D+00	0.2853D+02	0.9557D+01	0.4584D+05
43	300	0.9777D+00	0.2227D-01	0.4482D+00	0.2853D+02	0.9557D+01	0.4584D+05
44	300	0.9617D+00	0.3832D-01	0.1767D+00	0.2853D+02	0.9557D+01	0.4584D+05
45	300	0.9920D+00	0.8047D-02	0.1276D-01	0.2853D+02	0.9557D+01	0.4584D+05
49	300	0.1000D+01	0.7296D-11	0.6381D-10	0.2853D+02	0.9557D+01	0.4584D+05
50	300	0.1000D+01	0.4087D-11	0.8470D-11	0.2853D+02	0.9557D+01	0.4584D+05
41	300	0.9992D+00	0.7670D-03	0.6106D+00	0.2853D+02	0.9557D+01	0.4584D+05

SORTED MAXIMUM RISK OF RUPTURE INTENSITIES AND CORRESPONDING ELEMENT NUMBERS

ELEMENT	RISK RUP. INT.
41	0.6106D+00
42	0.5734D+00
43	0.4482D+00
44	0.1767D+00
45	0.1276D-01
6	0.4425D-04
7	0.1427D-07
8	0.3829D-09
49	0.6381D-10
50	0.8470D-11

FOR F.E. MODEL SURFACE --- PROBABILITY OF FAILURE = 0.7342D-01
PROBABILITY OF SURVIVAL = 0.9266D+00

```
*****  
*                                     *  
*           OVERALL COMPONENT STATISTICS           *  
*                                     *  
*****
```

COMPONENT FAILURE PROBABILITY = 0.8715D+00
COMPONENT SURVIVAL PROBABILITY = 0.1285D+00

Example 2—Rotating Annular Disk

To validate the Batdorf shear-insensitive crack model for volume flaw analysis, results from equation (40b) with $\tau = 0$ were compared with failure predictions obtained from equation (13) for a silicon nitride annular disk rotating at various speeds (ref. 55). The disk inside diameter was 12.7 mm (0.50 in.), the outside diameter was 82.55 mm (3.25 in.), and the disk was 3.8 mm (0.15 in.) thick (fig. 18). Weibull material parameters were independently evaluated from four-point MOR bar tests of 85 specimens. The Weibull modulus \hat{m}_V was 7.65 and the characteristic modulus of rupture $\hat{MOR}_{o,V}$ was 808 MPa (117 000 psi) for the "A-size" bars (ref. 55).

For volume flaws, equations (62) and (75) can be used to calculate the Weibull scale parameter $\sigma_{o,V}$. With the given "A-size" bar geometry $w = 6.35$ mm (0.25 in.), $h = 3.175$ mm (0.125 in.), $L_1 = 19.050$ mm (0.75 in.), $L_2 = 9.525$ mm (0.375 in.), we obtain $\sigma_{o,V} = 74.79$ MPa (m)^{0.3922} (45 800 psi (in.)^{0.3922}). The normalized Batdorf crack density coefficient \bar{k}_{BV} for shear-insensitive models is $(2m_V + 1)$ or 16.30 (eq. (81)). All calculations used the English system of units. Other required material properties include a Young's modulus of 289 GPa (41.9×10^6 psi) and a Poisson's ratio of 0.219. The material mass density was 3.25 g/cm³ (3.0×10^{-4} (lb-sec²)/in.⁴), which results in a weight density of 0.117 lb/in.³. Rotational speeds were varied between 70 000 and 130 000 rpm to cover the entire range of failure probabilities predicted by the various fracture models within CARES.

Seven disks were fracture tested and the experimental disk Weibull modulus of 4.95 was considerably different from the 7.65 value (ref. 55) based on MOR specimen data. A better agreement between disk and MOR Weibull slopes would lead to improved predictions in failure probabilities for the entire range. Estimation of parameters from small sample sets greatly increases potential deviation from the true population

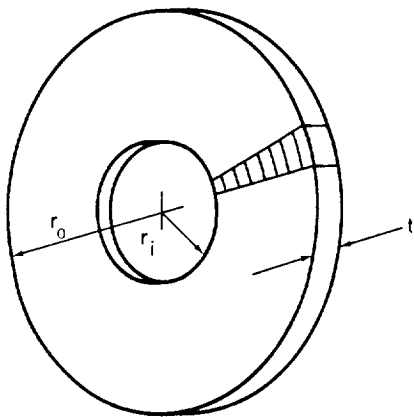

Figure 18.—Rotating annular disk with 15° sector finite element mesh containing eight HEXA elements. Material, NC-132 hot-pressed Si₃N₄; inner disk radius, r_i , 6.35 mm (0.25 in.); outer disk radius, r_o , 41.28 mm (1.63 in.); disk thickness, t , 3.80 mm (0.15 in.); velocity range, 70 000 to 130 000 rpm. (Not to scale.)

parameters. Confidence limits are used to measure the intrinsic uncertainties in parameter estimates from finite sample sizes. The 90-percent confidence limits on m can be obtained from reference 38. For the 85 MOR specimens, with $m_1 = 7.65$, the calculated limits are 6.56 and 8.68. Similarly, for the seven fractured disks and the estimated m_1 of 4.95, the 90-percent confidence limits are 2.27 and 6.98. Excluding potential experimental errors, it is possible that the rotating disks and the MOR bars broke because of the same flaw population since their 90-percent confidence limits overlap between 6.56 and 6.98. Therefore, it cannot be concluded with absolute certainty that the disks broke from a different flaw population than the MOR bars unless further testing is performed. The apparent difference between experiments is not significant enough to cause rejection of the hypothesis that the bars and disks broke because of the same flaw population.

It should be noted that Swank and Williams (ref. 55) also spin tested a contoured hub and a turbine blade ring geometry. Using Weibull material parameters obtained from MOR bars cut from the respective hub and blade ring, their correlation of m was much better than with the annular disk results. They also noted that the material parameters used for the annular disks were obtained under less tightly controlled conditions than with the other geometries.

The finite element model of the disk consisted of brick elements and used the static cyclic symmetry analysis Rigid Format 47 solution sequence. Because of symmetry, only eight HEXA elements were used in one 15° sector for the model of the disk (fig. 18). One element spans both the thickness and circumferential directions. The calculated NASTRAN stresses and element volumes were both within approximately 1 percent of the available closed-form answers for this problem. A model with twice as many elements along the radial direction was also analyzed to check mesh convergence, and the resulting stresses were extremely close to those obtained with only eight HEXA elements. The number of Gauss points used in the numerical integration for reliability was set to 15 (NGP = 15). The MSC/NASTRAN example 2 input file is shown at the end of this problem, with the disk at a uniform 21 °C (70 °F) temperature and spinning at 93 000 rpm (1550 rev/sec).

The CARES volume-flaw reliability results of the disk calculated with the Batdorf shear-insensitive fracture model were compared with data calculated at the Ford Motor Co. The Ford calculations used equation (13) and linear axisymmetric finite elements (ref. 55). The agreement between failure predictions from CARES2 and the Ford analysis was within 10 percent, with the difference probably due to the different stress-volume data used in solving the reliability problem. With the same nodal spacing as for the eight-element cyclic symmetry analysis and with 16 TRIAX6 axisymmetric elements at a disk speed of 93 000 rpm, the failure predictions were less than those from the CARES1 program (table VII). A more refined element mesh would reduce the difference between the CARES1 and CARES2 failure predictions.

TABLE VII.—FAILURE PROBABILITIES OF A ROTATING ANNULAR DISK—VOLUME FLAW ANALYSIS

[NGP = 15; $m_V = 7.65$; $\sigma_{iV} = 74.79 \text{ MPa(m)}^{3/7.65} (45\ 800 \text{ psi(in.)}^{3/7.65})$]

Angular speed, rpm	Failure probability										
	IKBAT = 0; $\bar{k}_{BV} = 16.30$									IKBAT = 1; $\bar{k}_{BV} = 2.99$	
	Shetty criterion ($\bar{C} = 0.80$)		Energy release rate criterion, G_T		Maximum tensile stress criterion		Normal stress criterion	Ford (ref. 55)		PIA criterion	Shetty criterion ($\bar{C} = 0.82$); Griffith crack (G_{max} approx.)
	Griffith crack	Penny-shaped crack	Griffith crack	Penny-shaped crack	Griffith crack	Penny-shaped crack		Normal stress criterion ^a	Experimental $m_V = 4.95$		
CARES2 results											
70 000	0.0116	0.0167	0.0046	0.0048	0.0032	0.0036	0.0027	0.0023	0.0583	0.0022	0.0020
75 000	.0328	.0472	.0131	.0138	.0092	.0104	.0078	.0067	.1121	.0062	.0058
80 000	.0854	.1212	.0347	.0365	.0244	.0275	.0206	.0179	.2017	.0164	.0153
85 000	.2034	.2803	.0859	.0902	.0612	.0686	.0517	.0446	.3367	.0413	.0385
93 000	.5922	.7269	.2984	.3115	.2204	.2445	.1888	.1650	.6321	.1532	.1437
100 000	.9349	.9808	.6601	.6790	.5315	.5742	.4712	.4223	.8714	.3973	.3763
104 000	.9929	.9992	.8584	.8723	.7468	.7870	.6846	.6321	.9514	.6003	.5748
110 000	1.0000	1.0000	.9901	.9922	.9608	.9740	.9343	.9055	.9949	.8851	.8670
114 000	1.0000	1.0000	.9997	.9998	.9963	.9982	.9910	.9830	.9994	.9764	.9696
120 000	1.0000	1.0000	1.0000	1.0000	1.0000	1.0000	1.0000	1.0000	.9999	.9997	.9995
125 000	1.0000	1.0000	1.0000	1.0000	1.0000	1.0000	1.0000	1.0000	1.0000	1.0000	1.0000
130 000	1.0000	1.0000	1.0000	1.0000	1.0000	1.0000	1.0000	1.0000	1.0000	1.0000	1.0000
CARES1 results											
93 000	0.5302	0.6631	0.2577	0.2700	0.1881	0.2087	0.1604	0.1650	0.6321	0.1311	0.1228
*93 000	.4962	.6288	.2375	.2492	.1727	.1909	.1477	.1650	.6321	.1192	.1118

^aFor axisymmetric elements.

TABLE VIII.—FAILURE PROBABILITIES OF A ROTATING ANNULAR DISK—SURFACE FLAW ANALYSIS

[NGP = 15; $m_S = 7.65$; $\sigma_{iS} = 232.0 \text{ MPa(m)}^{2/7.65} (87\ 890 \text{ psi(in.)}^{2/7.65})$]

Angular speed, rpm	Failure probability								
	IKBAT = 0; $\bar{k}_{BS} = 4.986$							IKBAT = 1; $\bar{k}_{BS} = 1.755$	
	Shetty criterion ($\bar{C} = 0.80$)			Energy release rate criterion, G_T		Normal stress criterion	PIA criterion	Shetty criterion ($\bar{C} = 0.82$); Griffith crack (G_{max} approx.)	
	Griffith crack	Griffith notch	Semi-circular crack	Griffith crack	Griffith notch				
CARES2 results									
70 000	0.0011	0.0009	0.0009	0.0006	0.0006	0.0004	0.0004	0.0004	
75 000	.0031	.0026	.0026	.0017	.0017	.0013	.0012	.0011	
80 000	.0084	.0068	.0070	.0045	.0045	.0034	.0031	.0029	
85 000	.0212	.0173	.0178	.0113	.0114	.0087	.0078	.0073	
93 000	.0810	.0664	.0685	.0439	.0441	.0339	.0304	.0284	
100 000	.2267	.1888	.1942	.1276	.1283	.0996	.0898	.0839	
104 000	.3724	.3155	.3237	.2191	.2202	.1730	.1568	.1468	
110 000	.6668	.5911	.6026	.4421	.4439	.3612	.3312	.3125	
114 000	.8509	.7875	.7977	.6360	.6381	.5399	.5018	.4774	
120 000	.9846	.9664	.9699	.8909	.8922	.8176	.7828	.7589	
125 000	.9996	.9982	.9985	.9839	.9842	.9580	.9419	.9293	
130 000	1.0000	1.0000	1.0000	.9995	.9995	.9970	.9945	.9922	
CARES1 results									
93 000	0.0789	0.0646	0.0667	0.0427	0.0430	0.0330	0.0296	0.0276	

Experimental results are plotted in figure 19, along with shear-insensitive and various shear-sensitive predictions from CARES2.

As with the pressure-loaded disk of example 1, laboratory measurements agree best with the shear-sensitive fracture models that use the $IKBAT = 0$ option. The results are summarized in table VII. In addition, results are given in table VII for an approximation of the maximum strain energy release rate criterion G_{max} , with a Griffith crack (Shetty's criterion with $\bar{C} = 0.82$ and $IKBAT = 1$). Failure probabilities calculated from decreasing shear-sensitive effective stress equations move the probability of failure curves towards the shear-insensitive case as shown in figure 19. It is observed that Shetty's criterion for $\bar{C} = 0.80$, $IKBAT = 0$, and the penny-shaped crack gives the best agreement with experimental data. For $IKBAT = 0$, the results get progressively better in the order: PIA, normal stress, maximum tensile stress, energy release rate G_T , and Shetty's criterion. The results for $IKBAT = 1$ (fig. 19) show that increasing shear sensitivity gives even less conservative predictions than the PIA model. Interestingly for both examples 1 and 2, the $IKBAT = 1$ option gives results that are in reasonable agreement with PIA predictions when the Shetty fracture criterion and the Griffith crack geometry are selected.

The same rotating annular disks were analyzed assuming that fractures in the MOR bars as well as the disks were caused by surface flaws. This analysis was done for illustrative purposes only. The Weibull modulus was set equal to $m_S = 7.65$ as before. The surface scale parameter σ_{oS} was calculated from equation (90a) and had a value of $232.0 \text{ MPa}(\text{m})^{0.2614}$ ($87\,890 \text{ psi}(\text{in.})^{0.2614}$). The same MSC/NASTRAN analysis

was performed as for volume flaws with the addition of shell elements to model external surfaces. Reliability calculations were made as a function of disk rotational speed for several surface crack fracture models. Selected results from these analyses are shown in figure 20 and table VIII. Unlike example 1 (fig. 17), the shear-sensitive results show some variation between the normal stress and the Shetty criterion for $IKBAT = 0$. This is expected because stress state dependence plays a major role in the failure predictions. The results given in table VIII for the G_{max} criterion with a Griffith crack, and Shetty's criterion with $\bar{C} = 0.82$, and $IKBAT = 1$ show that increasing shear sensitivity yields a less conservative prediction than the PIA model, although they are almost identical as previously observed. For a given speed, failure probabilities are considerably less than those obtained by volume flow analysis for all fracture models, indicating that failure was most likely due to volume flaws as originally concluded. The main reason for the greatly decreased failure estimates is the much higher equivalent surface Weibull scale parameter σ_{oS} . The importance of postmortem fractography to identify the nature of the fracture-causing flaws is evident from the two widely different sets of answers in figures 19 and 20.

The CARES input and output files are given at the end of this example problem. For this example, the material parameter estimation procedures within CARES were not utilized because the required data were directly read.

In addition to comparing surface and volume analyses for the same component, failure probability was calculated for a transversely loaded circular alumina disk and compared with data obtained by Brockenbrough, Forsythe, and Rolf (ref. 56).

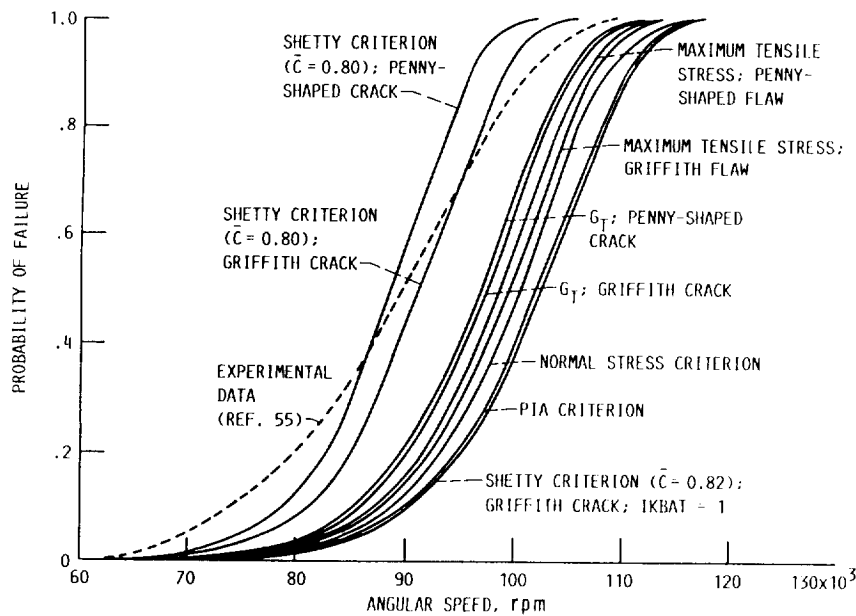

Figure 19.—Comparison of experimental failure probabilities with those for various fracture models for a rotating annular disk (volume flow analysis). $NGP = 15$; $m_V = 7.65$; $\sigma_{oV} = 74.79 \text{ MPa}(\text{m})^{3/7.65}$ ($45\,800 \text{ psi}(\text{in.})^{3/7.65}$). For $IKBAT = 0$, $\bar{k}_{BV} = 16.30$; for $IKBAT = 1$, $\bar{k}_{BV} = 2.99$ (only for Griffith crack, Shetty criterion, $\bar{C} = 0.82$).

These data consisted of calculated failure probabilities obtained from Batdorf's shear-insensitive fracture theory for surface flaws in conjunction with the finite element analysis code ANSYS. The selected disk had an outside radius r_o of 25 mm (0.984 in.) and a thickness t of 2.5 mm (0.098 in.). It was loaded by a circular line load at $r = 1.5$ mm (0.059 in.) and was simply supported at a radius of 22 mm (0.866 in.). After matching the stress solutions for a given load from the two different finite element codes (MSC/NASTRAN and ANSYS), the failure probabilities were calculated at various loads. Typically, to obtain a P_{fS} of 0.50, CARES2 predicted a

total line load of 1105 N (248.3 lb), whereas according to Brockenbrough et al. (ref. 56, corrected version) a line load of approximately 1130 N (253.9 lb) had to be applied, which shows good agreement between the two load predictions.

Reliability calculations were also completed for lapped specimens in uniaxial and equibiaxial loading (ref. 21), closely duplicating the PIA results obtained in that publication. Excellent agreement was also obtained between the CARES2 predictions and the published results for the concentric ring specimen analyzed and tested by Giovan and Sines (ref. 21).

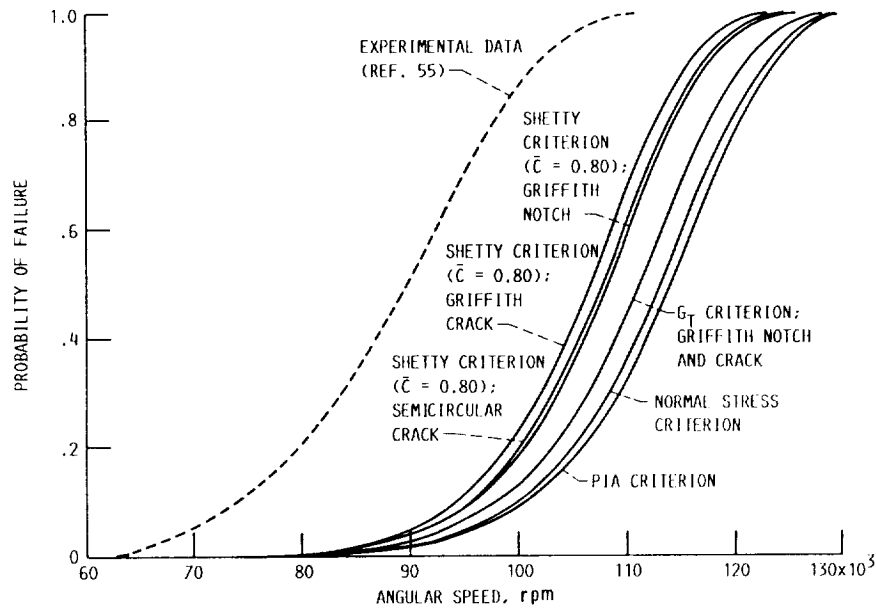

Figure 20.—Comparison of experimental failure probabilities with those for various fracture models for a rotating annular disk (surface flaw analysis). $NGP = 15$; $m_S = 7.65$; $\sigma_{oS} = 232.0 \text{ MPa}(\text{m})^{2/7.65}$ (87 890 $\text{psi}(\text{in.})^{2/7.65}$); for $IKBAT = 0$, $\bar{k}_{BS} = 4.986$.

NASTRAN INPUT FILE

```

# USER=_____ PW=_____
# QSUB -r example2 # job name
# QSUB -eo # combine stderr and stdout
# QSUB -lM 1.0mw # set memory limit
# QSUB -lt 00:01:00 # set cpu time limit
set -v kx
cd
cat >ex2nastin<<"EOF"
NASTRAN DAYLIMIT = -1
ID CERAMIC,FRACTURE
APP DISP
SOL 47
TIME 30
CEND
TITLE = ROTATING ANNULAR DISK
SUBTITLE = SOLID ELEMENTS WITH CYCLIC SYMMETRY MODELING
SET 2 = 0
HARMONICS =2
SPC=1
LOAD=10
SET 5= 1
NOUTPUT=5
DISP=ALL
ECHO=PUNCH
STRESS(PRINT,PUNCH)=ALL
OUTPUT(PLOT)
PLOTTER NAST
SET 1=ALL
AXES MX,MY,MZ
PTITLE = ROTATING ANNULAR DISK
FIND SCALE,ORIGIN 1,SET 1
PLOT SYMBOLS 5, LABEL BOTH SHAPE
MAXIMUM DEFORMATION
PLOT STATIC DEFORMATION,SET 1
BEGIN BULK
$. . . . . 2 . . . . . 3 . . . . . 4 . . . . . 5 . . . . . 6 . . . . . 7 . . . . . 8 . . . . . 9 . . . . . 10 . . . . .
CQUAD8,130,101,1,27,88,62,18,53,+Q30
+Q30,79,44
CQUAD8,100,101,1,3,29,27,2,19,+Q00
+Q00,28,18
CQUAD8,101,101,3,5,31,29,4,20,+Q01
+Q01,30,19
CQUAD8,102,101,5,7,33,31,6,21,+Q02
+Q02,32,20
CQUAD8,103,101,7,9,35,33,8,22,+Q03
+Q03,34,21
CQUAD8,104,101,9,11,37,35,10,23,+Q04
+Q04,36,22
CQUAD8,105,101,11,13,39,37,12,24,+Q05
+Q05,38,23
CQUAD8,106,101,13,15,41,39,14,25,+Q06
+Q06,40,24
CQUAD8,107,101,15,17,43,41,16,26,+Q07
+Q07,42,25
CQUAD8,110,101,62,64,90,88,63,80,+Q11

```

```

+Q11,89,79
CQUAD8,111,101,64,66,92,90,65,81,+Q10
+Q10,91,80
CQUAD8,112,101,66,68,94,92,67,82,+Q12
+Q12,93,81
CQUAD8,113,101,68,70,96,94,69,83,+Q13
+Q13,95,82
CQUAD8,114,101,70,72,98,96,71,84,+Q14
+Q14,97,83
CQUAD8,115,101,72,74,100,98,73,85,+Q15
+Q15,99,84
CQUAD8,116,101,74,76,102,100,75,86,+Q16
+Q16,101,85
CQUAD8,117,101,76,78,104,102,77,87,+Q17
+Q17,103,86
CQUAD8,120,101,17,43,104,78,26,61,+Q20
+Q20,87,52
CHEXA 1      100      1      3      29      27      62      64      +C11
+C11  90      88      2      19     28      18      44      45      +C12
+C12  54      53      63     80     89      79
CHEXA 2      100      3      5      31      29      64      66      +C21
+C21  92      90      4      20     30      19      45      46      +C22
+C22  55      54      65     81     91      80
CHEXA 3      100      5      7      33      31      66      68      +C31
+C31  94      92      6      21     32      20      46      47      +C32
+C32  56      55      67     82     93      81
CHEXA 4      100      7      9      35      33      68      70      +C41
+C41  96      94      8      22     34      21      47      48      +C42
+C42  57      56      69     83     95      82
CHEXA 5      100      9      11     37      35      70      72      +C51
+C51  98      96      10     23     36      22      48      49      +C52
+C52  58      57      71     84     97      83
CHEXA 6      100      11     13     39      37      72      74      +C61
+C61  100     98      12     24     38      23      49      50      +C62
+C62  59      58      73     85     99      84
CHEXA 7      100      13     15     41      39      74      76      +C71
+C71  102     100     14     25     40      24      50      51      +C72
+C72  60      59      75     86     101     85
CHEXA 8      100      15     17     43      41      76      78      +C81
+C81  104     102     16     26     42      25      51      52      +C82
+C82  61      60      77     87     103     86
GRID  1      .25     0.     0.
GRID  2      .275    0.     0.
GRID  3      .30     0.     0.
GRID  4      .35     0.     0.
GRID  5      .40     0.     0.
GRID  6      .45     0.     0.
GRID  7      .50     0.     0.
GRID  8      .55     0.     0.
GRID  9      .60     0.     0.
GRID  10     .65     0.     0.
GRID  11     .70     0.     0.
GRID  12     .75     0.     0.
GRID  13     .80     0.     0.
GRID  14     .90     0.     0.

```

GRID	15	1.0	0.	0.
GRID	16	1.3	0.	0.
GRID	17	1.625	0.	0.
GRID	18	.25	7.5	0.
GRID	19	.30	7.5	0.
GRID	20	.40	7.5	0.
GRID	21	.50	7.5	0.
GRID	22	.60	7.5	0.
GRID	23	.70	7.5	0.
GRID	24	.80	7.5	0.
GRID	25	1.0	7.5	0.
GRID	26	1.625	7.5	0.
GRID	27	.25	15.	0.
GRID	28	.275	15.	0.
GRID	29	.30	15.	0.
GRID	30	.35	15.	0.
GRID	31	.40	15.	0.
GRID	32	.45	15.	0.
GRID	33	.50	15.	0.
GRID	34	.55	15.	0.
GRID	35	.60	15.	0.
GRID	36	.65	15.	0.
GRID	37	.70	15.	0.
GRID	38	.75	15.	0.
GRID	39	.80	15.	0.
GRID	40	.90	15.	0.
GRID	41	1.0	15.	0.
GRID	42	1.3	15.	0.
GRID	43	1.625	15.	0.
GRID	44	.25	0.	0.075
GRID	45	.30	0.	0.075
GRID	46	.40	0.	0.075
GRID	47	.50	0.	0.075
GRID	48	.60	0.	0.075
GRID	49	.70	0.	0.075
GRID	50	.80	0.	0.075
GRID	51	1.0	0.	0.075
GRID	52	1.625	0.	0.075
GRID	53	.25	15.	0.075
GRID	54	.30	15.	0.075
GRID	55	.40	15.	0.075
GRID	56	.50	15.	0.075
GRID	57	.60	15.	0.075
GRID	58	.70	15.	0.075
GRID	59	.80	15.	0.075
GRID	60	1.0	15.	0.075
GRID	61	1.625	15.	0.075
GRID	62	.25	0.	0.15
GRID	63	.275	0.	0.15
GRID	64	.30	0.	0.15
GRID	65	.35	0.	0.15
GRID	66	.40	0.	0.15
GRID	67	.45	0.	0.15
GRID	68	.50	0.	0.15
GRID	69	.55	0.	0.15

GRID	70		.60	0.	0.15				
GRID	71		.65	0.	0.15				
GRID	72		.70	0.	0.15				
GRID	73		.75	0.	0.15				
GRID	74		.80	0.	0.15				
GRID	75		.90	0.	0.15				
GRID	76		1.0	0.	0.15				
GRID	77		1.3	0.	0.15				
GRID	78		1.625	0.	0.15				
GRID	79		.25	7.5	0.15				
GRID	80		.30	7.5	0.15				
GRID	81		.40	7.5	0.15				
GRID	82		.50	7.5	0.15				
GRID	83		.60	7.5	0.15				
GRID	84		.70	7.5	0.15				
GRID	85		.80	7.5	0.15				
GRID	86		1.0	7.5	0.15				
GRID	87		1.625	7.5	0.15				
GRID	88		.25	15.	0.15				
GRID	89		.275	15.	0.15				
GRID	90		.30	15.	0.15				
GRID	91		.35	15.	0.15				
GRID	92		.40	15.	0.15				
GRID	93		.45	15.	0.15				
GRID	94		.50	15.	0.15				
GRID	95		.55	15.	0.15				
GRID	96		.60	15.	0.15				
GRID	97		.65	15.	0.15				
GRID	98		.70	15.	0.15				
GRID	99		.75	15.	0.15				
GRID	100		.80	15.	0.15				
GRID	101		.90	15.	0.15				
GRID	102		1.0	15.	0.15				
GRID	103		1.3	15.	0.15				
GRID	104		1.625	15.	0.15				
CYJOIN	1		1	THRU	17	44	THRU	52	+BC
+BC	62	THRU	78						
CYJOIN	2		27	THRU	43	53	THRU	61	+FG
+FG	88	THRU	104						
SPC1	1	3456	44	THRU	52				
SPC1	1	3456	53	THRU	61				
CORD2C	5	0	0.	0.	0.	0.	0.	1.	+C
+C	1.	90.	0.						
CYSYM	24	ROT							
GRDSET		5				5	456		
PSOLID	100	300	5						
PSHELL	,101,300,	.000001							
MAT1	300	4.19+7		0.219	3.000-4				
TEMPD	,2,70.								
PARAM	EST	1							
LOADCYH	10	1.0	0	RFORCE	1.0	20			
RFORCE	20		5	1550.	0.	0.	1.0	2	
ENDDATA									
EOF									
mscnast	in=ex2nastin								

CARES TEMPLAT INPUT FILE

*
* RELIABILITY PREDICTION FOR BRITTLE MATERIAL STRUCTURES *
* --- FAST FRACTURE STATISTICS --- *
*

MASTER CONTROL INPUT

TITLE : PROBLEM TITLE (ECHOED IN CARES OUTPUT)

EXAMPLE PROBLEM 2 : ROTATING ANNULAR DISK

NE : CONTROL INDEX FOR FINITE ELEMENT POSTPROCESSING

(DEFAULT: NE = 0)
1 0 : EXPERIMENTAL DATA ANALYSIS ONLY

1 : MSC/NASTRAN ANALYSIS
2 : ANSYS ANALYSIS

NMATS : NO. OF MATERIALS FOR SURFACE FLAW ANALYSIS

(NMATS+NMATV < 101)
01 (DEFAULT: NMATS = 0)

NMATV : NO. OF MATERIALS FOR VOLUME FLAW ANALYSIS

(NMATS+NMATV < 101)
01 (DEFAULT: NMATV = 0)

IPRINT : CONTROL INDEX FOR STRESS OUTPUT

(DEFAULT: IPRINT = 0)
1 0 : DO NOT PRINT ELEMENT STRESSES AND/OR FRACTURE DATA

1 : PRINT ELEMENT STRESSES AND/OR FRACTURE DATA

LONL : CONTROL INDEX FOR LINEAR OR QUADRATIC ELEMENTS

(DEFAULT: LONL = 0)
1 0 : LINEAR

1 : QUADRATIC (MIDSIDE NODES REQUIRED)

NGP : NO. OF GAUSSIAN QUADRATURE POINTS (15 OR 30)

(DEFAULT: NGP = 15)
15

NS : NO. OF SEGMENTS IN CYCLIC SYMMETRY PROBLEM

(DEFAULT: NS = 1)
024

\$ENDX : END OF MASTER CONTROL INPUT

MATERIAL CONTROL INPUT

TITLE : MATERIAL TITLE (ECHOED IN CARES OUTPUT)

SI3N4 SPECIMEN DATA FOR VOLUME FLAW ANALYSIS (REF. SWANK AND WILLIAMS)

MATID : MATERIAL IDENTIFICATION NO. FROM THE FINITE ELEMENT

MATERIAL PROPERTY CARD (IF POSTPROCESSING IS NOT
0000300 BEING PERFORMED THIS ENTRY SHOULD BE SOME UNIQUE NO.)

(NO DEFAULT)

ID1 : CONTROL INDEX FOR EXPERIMENTAL DATA

(NO DEFAULT)
3

1 : UNIFORM UNIAXIAL TENSILE SPECIMEN TEST DATA
2 : FOUR-POINT BEND TEST DATA
3 : DIRECT INPUT OF THE WEIBULL PARAMETERS, M AND SP
(SHAPE PARAMETER AND SCALE PARAMETER)
4 : CENSORED DATA FOR SUSPENDED ITEM ANALYSIS OF
UNIFORM UNIAXIAL TENSILE SPECIMEN TEST DATA
5 : CENSORED DATA FOR SUSPENDED ITEM ANALYSIS OF
FOUR-POINT BEND TEST DATA

ID4 : CONTROL INDEX FOR VOLUME OR SURFACE FLAW ANALYSIS

(NO DEFAULT)
1

1 : VOLUME
2 : SURFACE

ID2V : CONTROL INDEX FOR VOLUME FRACTURE CRITERION

(NO DEFAULT)
5

1 : NORMAL STRESS FRACTURE CRITERION
(SHEAR-INSENSITIVE CRACK)
2 : MAXIMUM TENSILE STRESS CRITERION
3 : COPLANAR STRAIN ENERGY RELEASE RATE CRITERION
(G SUB T)
4 : WEIBULL PIA MODEL
5 : SHETTY'S SEMI-EMPIRICAL CRITERION

ID3V : CONTROL INDEX FOR SHAPE OF VOLUME CRACKS

(NO DEFAULT)
2

1 : GRIFFITH CRACK
2 : PENNY-SHAPED CRACK

IKBAT : CONTROL INDEX FOR METHOD OF CALCULATING BATDORF CRACK

DENSITY COEFFICIENT (K SUB B) FROM TEST DATA
0

(DEFAULT: IKBAT = 0)
0 : SHEAR-INSENSITIVE METHOD (MODE I FRACTURE ASSUMED)
1 : SHEAR-SENSITIVE METHOD (FRACTURE ASSUMED TO OCCUR
ACCORDING TO THE FRACTURE CRITERION AND CRACK SHAPE
SELECTED BY THE ID2 AND ID3 INDICES)

PR : POISSON'S RATIO

(DEFAULT: PR = 0.25)
00000.2190

C : CONSTANT FOR SHETTY'S SEMI-EMPIRICAL MIXED-MODE FRACTURE

CRITERION $(K_I/K_{IC}) + (K_{II}/(C * K_{IC}))^{**2} = 1$
00000.8000 OBSERVED VALUES RANGE FROM 0.8 TO 2. (REF. D.K. SHETTY)

NOTE: AS C APPROACHES INFINITY, PREDICTED FAILURE
PROBABILITIES APPROACH NORMAL STRESS CRITERION VALUES
(DEFAULT C = 1.0)

\$ENDM : END OF TEMPERATURE INDEPENDENT MATERIAL CONTROL INPUT

TEMPERATURE DEPENDENT MATERIAL CONTROL INPUT DATA
FOR THE ABOVE MATERIAL

!!
PLEASE NOTE THE FOLLOWING:
1. TEMPERATURE DEPENDENT DATA SETS MUST BE ARRANGED IN ASCENDING ORDER
ACCORDING TO TEMPERATURE.
2. MAXIMUM NUMBER OF TEMPERATURE SETS IS 20.
!!

TDEG : TEMPERATURE OF THIS SET

00070.0000

PARAM : WEIBULL MODULUS (SHAPE PARAMETER) AND SCALE PARAMETER
-WEIBULL MODULUS--SCALE PARAMETER-
0.765000E+01 0.458000E+05

END OF DATA FOR THE ABOVE TEMPERATURE

\$ENDT : END OF DATA FOR THE ABOVE MATERIAL

MATERIAL CONTROL INPUT

TITLE : MATERIAL TITLE (ECHOED IN CARES OUTPUT)

SI3N4 SPECIMEN DATA FOR SURFACE FLAW ANALYSIS (REF. SWANK AND WILLIAMS)

MATID : MATERIAL IDENTIFICATION NO. FROM THE FINITE ELEMENT

MATERIAL PROPERTY CARD (IF POSTPROCESSING IS NOT
0000300 BEING PERFORMED THIS ENTRY SHOULD BE SOME UNIQUE NO.)

(NO DEFAULT)

ID1 : CONTROL INDEX FOR EXPERIMENTAL DATA

(NO DEFAULT)
3 1 : UNIFORM UNIAXIAL TENSILE SPECIMEN TEST DATA

2 : FOUR-POINT BEND TEST DATA

- 3 : DIRECT INPUT OF THE WEIBULL PARAMETERS, M AND SP
(SHAPE PARAMETER AND SCALE PARAMETER)
- 4 : CENSORED DATA FOR SUSPENDED ITEM ANALYSIS OF
UNIFORM UNIAXIAL TENSILE SPECIMEN TEST DATA
- 5 : CENSORED DATA FOR SUSPENDED ITEM ANALYSIS OF
FOUR-POINT BEND TEST DATA

ID4 : CONTROL INDEX FOR VOLUME OR SURFACE FLAW ANALYSIS

 (NO DEFAULT)
 2 1 : VOLUME

 2 : SURFACE

ID2S : CONTROL INDEX FOR SURFACE FRACTURE CRITERION

 (NO DEFAULT)
 5 1 : NORMAL STRESS FRACTURE CRITERION

 (SHEAR-INSENSITIVE CRACK)
 3 : COPLANAR STRAIN ENERGY RELEASE RATE CRITERION
 (G SUB T)
 4 : WEIBULL PIA MODEL
 5 : SHETTY'S SEMI-EMPIRICAL CRITERION

ID3S : CONTROL INDEX FOR SHAPE OF SURFACE CRACKS

 (NO DEFAULT)
 4 1 : GRIFFITH CRACK

 (ASSOCIATED WITH STRAIN ENERGY RELEASE RATE CRIT.)
 (ASSOCIATED WITH SHETTY'S SEMI-EMPIRICAL CRITERION)
 3 : GRIFFITH NOTCH
 (ASSOCIATED WITH STRAIN ENERGY RELEASE RATE CRIT.)
 (ASSOCIATED WITH SHETTY'S SEMI-EMPIRICAL CRITERION)
 4 : SEMICIRCULAR CRACK
 (ASSOCIATED WITH SHETTY'S SEMI-EMPIRICAL CRITERION)

IKBAT : CONTROL INDEX FOR METHOD OF CALCULATING BATDORF CRACK

 DENSITY COEFFICIENT (K SUB B) FROM TEST DATA
 0 (DEFAULT: IKBAT = 0)

 0 : SHEAR-INSENSITIVE METHOD (MODE I FRACTURE ASSUMED)
 1 : SHEAR-SENSITIVE METHOD (FRACTURE ASSUMED TO OCCUR
 ACCORDING TO THE FRACTURE CRITERION AND CRACK SHAPE
 SELECTED BY THE ID2 AND ID3 INDICES)

PR : POISSON'S RATIO

 (DEFAULT: PR = 0.25)
 00000.2190

C : CONSTANT FOR SHETTY'S SEMI-EMPIRICAL MIXED-MODE FRACTURE

 CRITERION $(KI/KIC)+(KII/(C*KIC))^{**2} = 1$
 00000.8000 OBSERVED VALUES RANGE FROM 0.8 TO 2. (REF. D.K. SHETTY)

 NOTE: AS C APPROACHES INFINITY, PREDICTED FAILURE
 PROBABILITIES APPROACH NORMAL STRESS CRITERION VALUES
 (DEFAULT: C = 1.0)

 \$ENDM : END OF TEMPERATURE INDEPENDENT MATERIAL CONTROL INPUT

TEMPERATURE DEPENDENT MATERIAL CONTROL INPUT DATA
FOR THE ABOVE MATERIAL

!!

PLEASE NOTE THE FOLLOWING:

1. TEMPERATURE DEPENDENT DATA SETS MUST BE ARRANGED IN ASCENDING ORDER ACCORDING TO TEMPERATURE.
2. MAXIMUM NUMBER OF TEMPERATURE SETS IS 20.

!!

TDEG : TEMPERATURE OF THIS SET

00070.0000

PARAM : WEIBULL MODULUS (SHAPE PARAMETER) AND SCALE PARAMETER

*-WEIBULL MODULUS-*SCALE PARAMETER-*

0.765000E+01 0.878910E+05

END OF DATA FOR THE ABOVE TEMPERATURE

\$ENDT : END OF DATA FOR THE ABOVE MATERIAL

CARES2 OUTPUT FILE

```

@@@@@@@@@@@@@@@@@@@@@@@@@@@@@@@@@@@@@@@@@@@@@@@@@@@@@@@@@@@@@@@@@@@@@@@@@@@@@@@@
@@@@
@@
@@
@@      CCCCCC          A          RRRRRRRR      EEEEEEEEE   SSSSSSS
@@      C          C      A A      R          R      E           S       S
@@      C          C      A  A      R          R      E           S       S
@@      C          C      A   A      RRRRRRRR      EEEEEEEE   SSSSSSS
@@      C          C      AAAAAAAA  R          R      E           S       S
@@      CCCCCC      A          A      R          R      EEEEEEEEE  SSSSSSS
@@
@@
@@      CERAMICS ANALYSIS AND RELIABILITY EVALUATION OF STRUCTURES
@@
@@@@@@@@@@@@@@@@@@@@@@@@@@@@@@@@@@@@@@@@@@@@@@@@@@@@@@@@@@@@@@@@@@@@@@@@@@@@@@@@
@@@@@@@@@@@@@@@@@@@@@@@@@@@@@@@@@@@@@@@@@@@@@@@@@@@@@@@@@@@@@@@@@@@@@@@@@@@@@@@@

```

```

*****
*                                     *
*          ECHO OF MASTER CONTROL INPUT          *
*                                     *
*****

```

TITLE = EXAMPLE PROBLEM 2 : ROTATING ANNULAR DISK

- 1 = CONTROL INDEX FOR FINITE ELEMENT POSTPROCESSING (NE)
 - 0 : EXPERIMENTAL DATA ANALYSIS ONLY
 - 1 : MSC/NASTRAN ANALYSIS
 - 2 : ANSYS ANALYSIS

- 1 = NUMBER OF MATERIALS FOR SURFACE FLAW ANALYSIS (NMATS)

- 1 = NUMBER OF MATERIALS FOR VOLUME FLAW ANALYSIS (NMATV)

- 15 = NUMBER OF GAUSSIAN QUADRATURE POINTS, EITHER 15 OR 30 (NGP)

- 24 = NUMBER OF SEGMENTS IN CYCLIC SYMMETRY PROBLEM (NS)

- 1 = CONTROL INDEX FOR LINEAR OR QUADRATIC ELEMENTS (LONL)
 - 0 : LINEAR (MIDSIDE NODES OPTIONAL)
 - 1 : QUADRATIC (MIDSIDE NODES REQUIRED)

- 1 = CONTROL INDEX FOR STRESS OUTPUT (IPRINT)
 - 0 : DO NOT PRINT ELEMENT STRESSES AND/OR FRACTURE DATA
 - 1 : PRINT ELEMENT STRESSES AND/OR FRACTURE DATA

```
XXXXXXXXXXXXXXXXXXXXXXXXXXXXXXXXXXXXXXXXXXXXXXXXXXXXXXXXXXXXX
X
X          ECHO OF FINITE ELEMENT ANALYSIS DATA          X
X                   PROCESSED BY CARES                   X
X
XXXXXXXXXXXXXXXXXXXXXXXXXXXXXXXXXXXXXXXXXXXXXXXXXXXXXXXXXXXXX
```

***** RESULTS FROM SEARCH OF MSC/NASTRAN BULK DATA *****

8 = TOTAL NUMBER OF SOLID ELEMENTS FOUND (NE)

8 = NUMBER OF HEXA ELEMENTS (NH)

0 = NUMBER OF PENTA ELEMENTS (NP)

0 = NUMBER OF TRIAX6 AXISYMMETRIC ELEMENTS (NA)

18 = TOTAL NUMBER OF SHELL ELEMENTS (NES)

18 = NUMBER OF QUAD8 SHELL ELEMENTS (NSQ)

0 = NUMBER OF TRIA6 SHELL ELEMENTS (NST)

***** MSC/NASTRAN STRESS ANALYSIS OUTPUT *****

\$TITLE = ROTATING ANNULAR DISK
 \$SUBTITLE= SOLID ELEMENTS WITH CYCLIC SYMMETRY MODELING

--- PRINCIPAL STRESSES AT THE CENTER OF EACH SUBELEMENT OR ELEMENT ---

\$ELEMENT TYPE = 67

HEXA ELEMENT OUTPUT

ELEMENT	PRC. STRESS I	PRC. STRESS II	PRC. STRESS III
1	0.6044806416E+05	0.1988647974E+04	0.4032008008E+03
	0.6044806367E+05	0.1987074832E+04	0.4047744335E+03
	0.6044806416E+05	0.1988647974E+04	0.4032008008E+03
	0.5727578272E+05	0.5049166941E+04	0.3607697423E+03
	0.5727578087E+05	0.5047941835E+04	0.3619967000E+03
	0.5727578272E+05	0.5049166941E+04	0.3607697423E+03
	0.5410393542E+05	0.8109701195E+04	0.3178892490E+03
	0.5410393110E+05	0.8108375800E+04	0.3192189665E+03
	0.5410393542E+05	0.8109701195E+04	0.3178892490E+03
	0.6010244835E+05	0.2333995677E+04	0.4034689078E+03
	0.6010244835E+05	0.2332690151E+04	0.4047744335E+03
	0.6010244835E+05	0.2333995677E+04	0.4034689078E+03
	0.5695238500E+05	0.5372501143E+04	0.3608332569E+03
	0.5695238500E+05	0.5371337700E+04	0.3619967000E+03
	0.5695238500E+05	0.5372501143E+04	0.3608332569E+03
	0.5380232165E+05	0.8411283977E+04	0.3179202375E+03
	0.5380232165E+05	0.8409985249E+04	0.3192189665E+03
	0.5380232165E+05	0.8411283977E+04	0.3179202375E+03
	0.6044806416E+05	0.1988647974E+04	0.4032008008E+03
	0.6044806367E+05	0.1987074832E+04	0.4047744335E+03
	0.6044806416E+05	0.1988647974E+04	0.4032008008E+03
	0.5727578272E+05	0.5049166941E+04	0.3607697423E+03
	0.5727578087E+05	0.5047941835E+04	0.3619967000E+03
	0.5727578272E+05	0.5049166941E+04	0.3607697423E+03
	0.5410393542E+05	0.8109701195E+04	0.3178892490E+03
	0.5410393110E+05	0.8108375800E+04	0.3192189665E+03
	0.5410393542E+05	0.8109701195E+04	0.3178892490E+03
2	0.5096080470E+05	0.1165905521E+05	0.4383959791E+03
	0.5096079899E+05	0.1165656601E+05	0.4408908833E+03
	0.5096080470E+05	0.1165905521E+05	0.4383959791E+03
	0.4774787576E+05	0.1452186520E+05	0.4465980875E+03
	0.4774786986E+05	0.1451984514E+05	0.4486240500E+03
	0.4774787576E+05	0.1452186520E+05	0.4465980875E+03
	0.4453529703E+05	0.1738448372E+05	0.4546414693E+03
	0.4453529100E+05	0.1738277399E+05	0.4563572167E+03
	0.4453529703E+05	0.1738448372E+05	0.4546414693E+03
	0.5070247668E+05	0.1191734562E+05	0.4384335825E+03
	0.5070247668E+05	0.1191488832E+05	0.4408908833E+03
	0.5070247668E+05	0.1191734562E+05	0.4384335825E+03
	0.4753961000E+05	0.1473011439E+05	0.4466146593E+03
	0.4753961000E+05	0.1472810500E+05	0.4486240500E+03
	0.4753961000E+05	0.1473011439E+05	0.4466146593E+03
	0.4437674332E+05	0.1754303046E+05	0.4546484340E+03
	0.4437674332E+05	0.1754132168E+05	0.4563572167E+03
	0.4437674332E+05	0.1754303046E+05	0.4546484340E+03
	0.5096080470E+05	0.1165905521E+05	0.4383959791E+03
	0.5096079899E+05	0.1165656601E+05	0.4408908833E+03
	0.5096080470E+05	0.1165905521E+05	0.4383959791E+03
	0.4774787576E+05	0.1452186520E+05	0.4465980875E+03
	0.4774786986E+05	0.1451984514E+05	0.4486240500E+03
	0.4774787576E+05	0.1452186520E+05	0.4465980875E+03
	0.4453529703E+05	0.1738448372E+05	0.4546414693E+03
	0.4453529100E+05	0.1738277399E+05	0.4563572167E+03
	0.4453529703E+05	0.1738448372E+05	0.4546414693E+03

ELEMENT

PRC. STRESS I

PRC. STRESS II

PRC. STRESS III

3

0.4176469322E+05	0.1838893024E+05	0.1719717275E+03
0.4176468875E+05	0.1838593626E+05	0.1749701830E+03
0.4176469322E+05	0.1838893024E+05	0.1719717275E+03
0.4020342635E+05	0.1966868790E+05	0.2370886934E+03
0.4020342381E+05	0.1966545119E+05	0.2403279500E+03
0.4020342635E+05	0.1966868790E+05	0.2370886934E+03
0.3864259898E+05	0.2094800646E+05	0.3022052797E+03
0.3864259797E+05	0.2094452702E+05	0.3056857170E+03
0.3864259898E+05	0.2094800646E+05	0.3022052797E+03
0.4163369501E+05	0.1851991192E+05	0.1719882584E+03
0.4163369501E+05	0.1851692999E+05	0.1749701830E+03
0.4163369501E+05	0.1851991192E+05	0.1719882584E+03
0.4009690500E+05	0.1977519100E+05	0.2371069492E+03
0.4009690500E+05	0.1977197000E+05	0.2403279500E+03
0.4009690500E+05	0.1977519100E+05	0.2371069492E+03
0.3856011499E+05	0.2103047037E+05	0.3022253515E+03
0.3856011499E+05	0.2102701001E+05	0.3056857170E+03
0.3856011499E+05	0.2103047037E+05	0.3022253515E+03
0.4176469322E+05	0.1838893024E+05	0.1719717275E+03
0.4176468875E+05	0.1838593626E+05	0.1749701830E+03
0.4176469322E+05	0.1838893024E+05	0.1719717275E+03
0.4020342635E+05	0.1966868790E+05	0.2370886934E+03
0.4020342381E+05	0.1966545119E+05	0.2403279500E+03
0.4020342635E+05	0.1966868790E+05	0.2370886934E+03
0.3864259898E+05	0.2094800646E+05	0.3022052797E+03
0.3864259797E+05	0.2094452702E+05	0.3056857170E+03
0.3864259898E+05	0.2094800646E+05	0.3022052797E+03

4

0.3710714929E+05	0.2096263312E+05	0.1019407979E+03
0.3710714870E+05	0.2095804297E+05	0.1065315413E+03
0.3710714929E+05	0.2096263312E+05	0.1019407979E+03
0.3618357045E+05	0.2160175697E+05	0.1799292223E+03
0.3618356987E+05	0.2159638513E+05	0.1853016450E+03
0.3618357045E+05	0.2160175697E+05	0.1799292223E+03
0.3526057561E+05	0.2224033792E+05	0.2578765493E+03
0.3526057518E+05	0.2223414316E+05	0.2640717487E+03
0.3526057561E+05	0.2224033792E+05	0.2578765493E+03
0.3703763334E+05	0.2103212262E+05	0.1019672472E+03
0.3703763334E+05	0.2102755833E+05	0.1065315413E+03
0.3703763334E+05	0.2103212262E+05	0.1019672472E+03
0.3612822000E+05	0.2165708159E+05	0.1799550562E+03
0.3612822000E+05	0.2165173500E+05	0.1853016450E+03
0.3612822000E+05	0.2165708159E+05	0.1799550562E+03
0.3521880666E+05	0.2228208226E+05	0.2579011601E+03
0.3521880666E+05	0.2227591167E+05	0.2640717487E+03
0.3521880666E+05	0.2228208226E+05	0.2579011601E+03
0.3710714929E+05	0.2096263312E+05	0.1019407979E+03
0.3710714870E+05	0.2095804297E+05	0.1065315413E+03
0.3710714929E+05	0.2096263312E+05	0.1019407979E+03
0.3618357045E+05	0.2160175697E+05	0.1799292223E+03
0.3618356987E+05	0.2159638513E+05	0.1853016450E+03
0.3618357045E+05	0.2160175697E+05	0.1799292223E+03
0.3526057561E+05	0.2224033792E+05	0.2578765493E+03
0.3526057518E+05	0.2223414316E+05	0.2640717487E+03
0.3526057561E+05	0.2224033792E+05	0.2578765493E+03

5

0.3416649544E+05	0.2163388234E+05	0.4993812527E+02
0.3416649520E+05	0.2162639647E+05	0.5742423269E+02
0.3416649544E+05	0.2163388234E+05	0.4993812527E+02
0.3354485194E+05	0.2197628320E+05	0.1781235614E+03
0.3354484482E+05	0.2196755018E+05	0.1868637000E+03
0.3354485194E+05	0.2197628320E+05	0.1781235614E+03
0.3292377881E+05	0.2231820250E+05	0.3062201896E+03
0.3292375366E+05	0.2230814468E+05	0.3163031673E+03
0.3292377881E+05	0.2231820250E+05	0.3062201896E+03
0.3412995167E+05	0.2167038570E+05	0.4997853366E+02
0.3412995167E+05	0.2166294000E+05	0.5742423269E+02
0.3412995167E+05	0.2167038570E+05	0.4997853366E+02
0.3351651500E+05	0.2200454998E+05	0.1781937207E+03

ELEMENT	PRC. STRESS I	PRC. STRESS II	PRC. STRESS III
5	0.3351651500E+05 0.3351651500E+05 0.3290307833E+05 0.3290307833E+05 0.3290307833E+05 0.3416649544E+05 0.3416649520E+05 0.3416649544E+05 0.3354485194E+05 0.3354484482E+05 0.3354485194E+05 0.3292377881E+05 0.3292375366E+05 0.3292377881E+05	0.2199588000E+05 0.2200454998E+05 0.2233879504E+05 0.2232882000E+05 0.2233879504E+05 0.2163388234E+05 0.2162639647E+05 0.2163388234E+05 0.2197628320E+05 0.2196755018E+05 0.2197628320E+05 0.2231820250E+05 0.2230814468E+05 0.2231820250E+05	0.1868637000E+03 0.1781937207E+03 0.3063281312E+03 0.3163031673E+03 0.3063281312E+03 0.4993812527E+02 0.5742423269E+02 0.4993812527E+02 0.1781235614E+03 0.1868637000E+03 0.1781235614E+03 0.3062201896E+03 0.3163031673E+03 0.3062201896E+03
6	0.3199710376E+05 0.3199709252E+05 0.3199710376E+05 0.3150694074E+05 0.3150694052E+05 0.3150694074E+05 0.3101711249E+05 0.3101709465E+05 0.3101711249E+05 0.3197677834E+05 0.3197677834E+05 0.3197677834E+05 0.3149091500E+05 0.3149091500E+05 0.3149091500E+05 0.3100505166E+05 0.3100505166E+05 0.3100505166E+05 0.3199710376E+05 0.3199709252E+05 0.3199710376E+05 0.3150694074E+05 0.3150694052E+05 0.3150694074E+05 0.3101711249E+05 0.3101709465E+05 0.3101711249E+05	0.2128028676E+05 0.2126864749E+05 0.2128028676E+05 0.2143677894E+05 0.2142183948E+05 0.2143677894E+05 0.2159337591E+05 0.2157472535E+05 0.2159337591E+05 0.2130052934E+05 0.2128896167E+05 0.2130052934E+05 0.2145277507E+05 0.2143786500E+05 0.2145277507E+05 0.2160543405E+05 0.2158676833E+05 0.2160543405E+05 0.2128028676E+05 0.2126864749E+05 0.2128028676E+05 0.2143677894E+05 0.2142183948E+05 0.2143677894E+05 0.2159337591E+05 0.2157472535E+05 0.2159337591E+05	0.5553754037E+02 0.6718805784E+02 0.5553754037E+02 0.1505314357E+03 0.1654711150E+03 0.1505314357E+03 0.2450857682E+03 0.2637541722E+03 0.2450857682E+03 0.5562038514E+02 0.6718805784E+02 0.5562038514E+02 0.1505610417E+03 0.1654711150E+03 0.1505610417E+03 0.2450884556E+03 0.2637541722E+03 0.2450884556E+03 0.5553754037E+02 0.6718805784E+02 0.5553754037E+02 0.1505314357E+03 0.1654711150E+03 0.1505314357E+03 0.2450857682E+03 0.2637541722E+03 0.2450857682E+03
7	0.3027644863E+05 0.3027644852E+05 0.3027644863E+05 0.2950885896E+05 0.2950861640E+05 0.2950885896E+05 0.2882114990E+05 0.2881979884E+05 0.2882114990E+05 0.3027641334E+05 0.3027641334E+05 0.3027641334E+05 0.2947354000E+05 0.2947354000E+05 0.2947354000E+05 0.2867066666E+05 0.2867066666E+05 0.2867066666E+05 0.3027644863E+05 0.3027644852E+05 0.3027644863E+05 0.2950885896E+05 0.2950861640E+05 0.2950885896E+05 0.2882114990E+05 0.2881979884E+05 0.2882114990E+05	0.2119876904E+05 0.2117897649E+05 0.2119876904E+05 0.2073850846E+05 0.2070579860E+05 0.2073850846E+05 0.2020228534E+05 0.2015360615E+05 0.2020228534E+05 0.2119880433E+05 0.2117901167E+05 0.2119880433E+05 0.2077382407E+05 0.2074087500E+05 0.2077382407E+05 0.2035276624E+05 0.2030273833E+05 0.2035276624E+05 0.2119876904E+05 0.2117897649E+05 0.2119876904E+05 0.2073850846E+05 0.2070579860E+05 0.2073850846E+05 0.2020228534E+05 0.2015360615E+05 0.2020228534E+05	0.3203063072E+03 0.3400989656E+03 0.3203063072E+03 0.5137152802E+03 0.5466677000E+03 0.5137152802E+03 0.7032061887E+03 0.7532364344E+03 0.7032061887E+03 0.3203063072E+03 0.3400989656E+03 0.3203063072E+03 0.5137186310E+03 0.5466677000E+03 0.5137186310E+03 0.7032085221E+03 0.7532364344E+03 0.7032085221E+03 0.3203063072E+03 0.3400989656E+03 0.3203063072E+03 0.5137152802E+03 0.5466677000E+03 0.5137152802E+03 0.7032061887E+03 0.7532364344E+03 0.7032061887E+03

ELEMENT	PRC. STRESS I	PRC. STRESS II	PRC. STRESS III
8	0.2548067043E+05	0.1363373621E+05	-0.5647420481E+03
	0.2547881753E+05	0.1353253667E+05	-0.4616896161E+03
	0.2548067043E+05	0.1363373621E+05	-0.5647420481E+03
	0.2225331816E+05	0.9763457137E+04	-0.7412356497E+03
	0.2225071115E+05	0.9599611355E+04	-0.5747828500E+03
	0.2225331816E+05	0.9763457137E+04	-0.7412356497E+03
	0.1902652839E+05	0.5964661884E+04	-0.9897755623E+03
	0.1902287090E+05	0.5666419893E+04	-0.6878760839E+03
	0.1902652839E+05	0.5964661884E+04	-0.9897755623E+03
	0.2535980168E+05	0.1375460469E+05	-0.5647417895E+03
	0.2535980168E+05	0.1365155252E+05	-0.4616896161E+03
	0.2535980168E+05	0.1375460469E+05	-0.5647417895E+03
	0.2213314500E+05	0.9883572607E+04	-0.7411779575E+03
	0.2213314500E+05	0.9717177500E+04	-0.5747828500E+03
	0.2213314500E+05	0.9883572607E+04	-0.7411779575E+03
	0.1890648832E+05	0.6083917733E+04	-0.9889913371E+03
	0.1890648832E+05	0.5782802480E+04	-0.6878760839E+03
	0.1890648832E+05	0.6083917733E+04	-0.9889913371E+03
	0.2548067043E+05	0.1363373621E+05	-0.5647420481E+03
	0.2547881753E+05	0.1353253667E+05	-0.4616896161E+03
	0.2548067043E+05	0.1363373621E+05	-0.5647420481E+03
	0.2225331816E+05	0.9763457137E+04	-0.7412356497E+03
	0.2225071115E+05	0.9599611355E+04	-0.5747828500E+03
	0.2225331816E+05	0.9763457137E+04	-0.7412356497E+03
	0.1902652839E+05	0.5964661884E+04	-0.9897755623E+03
	0.1902287090E+05	0.5666419893E+04	-0.6878760839E+03
	0.1902652839E+05	0.5964661884E+04	-0.9897755623E+03

\$ELEMENT TYPE = 64

QUAD8 ELEMENT OUTPUT

ELEMENT	PRC. STRESS I	PRC. STRESS II
100	0.5999688340E+05	0.1639524013E+04
	0.5999098835E+05	0.1645419068E+04
	0.5999688340E+05	0.1639524013E+04
	0.5682202301E+05	0.4718259436E+04
	0.5681852500E+05	0.4721757450E+04
	0.5682202301E+05	0.4718259436E+04
	0.5364762007E+05	0.7796537412E+04
	0.5364606165E+05	0.7798095832E+04
	0.5364762007E+05	0.7796537412E+04
101	0.5004284850E+05	0.1090948900E+05
	0.5004156668E+05	0.1091077082E+05
	0.5004284850E+05	0.1090948900E+05
	0.4685410731E+05	0.1383307119E+05
	0.4685226000E+05	0.1383491850E+05
	0.4685410731E+05	0.1383307119E+05
	0.4366566240E+05	0.1675635710E+05
	0.4366295332E+05	0.1675906618E+05
	0.4366566240E+05	0.1675635710E+05
102	0.4144216274E+05	0.1800283559E+05
	0.4143844001E+05	0.1800655833E+05
	0.4144216274E+05	0.1800283559E+05
	0.3987035022E+05	0.1929520478E+05
	0.3986548000E+05	0.1930007500E+05
	0.3987035022E+05	0.1929520478E+05
	0.3829895947E+05	0.2058715220E+05
	0.3829251999E+05	0.2059359167E+05
	0.3829895947E+05	0.2058715220E+05
103	0.3696482655E+05	0.2070072179E+05
	0.3695678000E+05	0.2070876833E+05

ELEMENT	PRC. STRESS I	PRC. STRESS II
103	0.3696482655E+05	0.2070072179E+05
	0.3602331384E+05	0.2133743116E+05
	0.3601322000E+05	0.2134752500E+05
	0.3602331384E+05	0.2133743116E+05
	0.3508237696E+05	0.2197356470E+05
	0.3506966000E+05	0.2198628167E+05
	0.3508237696E+05	0.2197356470E+05
104	0.3410564062E+05	0.2144696938E+05
	0.3409106000E+05	0.2146155000E+05
	0.3410564062E+05	0.2144696938E+05
	0.3345033680E+05	0.2176603320E+05
	0.3343310000E+05	0.2178327000E+05
	0.3345033680E+05	0.2176603320E+05
	0.3279558551E+05	0.2208454449E+05
	0.3277514000E+05	0.2210499000E+05
	0.3279558551E+05	0.2208454449E+05
	105	0.3197297139E+05
0.3195169334E+05		0.2117329333E+05
0.3197297139E+05		0.2115201528E+05
0.3145629691E+05		0.2128604309E+05
0.3143290000E+05		0.2130944000E+05
0.3145629691E+05		0.2128604309E+05
0.3093992604E+05		0.2141976729E+05
0.3091410666E+05		0.2144558667E+05
0.3093992604E+05		0.2141976729E+05
106		0.2990401776E+05
	0.2982838334E+05	0.1992288500E+05
	0.2990401776E+05	0.1984725058E+05
	0.2913973576E+05	0.1947772924E+05
	0.2893537000E+05	0.1968209500E+05
	0.2913973576E+05	0.1947772924E+05
	0.2844809835E+05	0.1903556331E+05
	0.2804235666E+05	0.1944130500E+05
	0.2844809835E+05	0.1903556331E+05
	107	0.2564625661E+05
0.2523265002E+05		0.1394852285E+05
0.2564625661E+05		0.1353491626E+05
0.2247102925E+05		0.9699429248E+04
0.2204891000E+05		0.1012154850E+05
0.2247102925E+05		0.9699429248E+04
0.1929601606E+05		0.5863728068E+04
0.1886516998E+05		0.6294574148E+04
0.1929601606E+05		0.5863728068E+04
110		0.5999688340E+05
	0.5999098835E+05	0.1645419068E+04
	0.5999688340E+05	0.1639524013E+04
	0.5682202301E+05	0.4718259436E+04
	0.5681852500E+05	0.4721757450E+04
	0.5682202301E+05	0.4718259436E+04
	0.5364762007E+05	0.7796537412E+04
	0.5364606165E+05	0.7798095832E+04
	0.5364762007E+05	0.7796537412E+04
	111	0.5004284850E+05
0.5004156668E+05		0.1091077082E+05
0.5004284850E+05		0.1090948900E+05
0.4685410731E+05		0.1383307119E+05
0.4685226000E+05		0.1383491850E+05
0.4685410731E+05		0.1383307119E+05
0.4366566240E+05		0.1675635710E+05
0.4366295332E+05		0.1675906618E+05
0.4366566240E+05		0.1675635710E+05

ELEMENT	PRC. STRESS I	PRC. STRESS II
112	0.4144216274E+05	0.1800283559E+05
	0.4143844001E+05	0.1800655833E+05
	0.4144216274E+05	0.1800283559E+05
	0.3987035022E+05	0.1929520478E+05
	0.3986548000E+05	0.1930007500E+05
	0.3987035022E+05	0.1929520478E+05
	0.3829895947E+05	0.2058715220E+05
	0.3829251999E+05	0.2059359167E+05
113	0.3829895947E+05	0.2058715220E+05
	0.3696482655E+05	0.2070072179E+05
	0.3695678000E+05	0.2070876833E+05
	0.3696482655E+05	0.2070072179E+05
	0.3602331384E+05	0.2133743116E+05
	0.3601322000E+05	0.2134752500E+05
	0.3602331384E+05	0.2133743116E+05
	0.3508237696E+05	0.2197356470E+05
114	0.3506966000E+05	0.2198628167E+05
	0.3508237696E+05	0.2197356470E+05
	0.3410564062E+05	0.2144696938E+05
	0.3409106000E+05	0.2146155000E+05
	0.3410564062E+05	0.2144696938E+05
	0.3345033680E+05	0.2176603320E+05
	0.3343310000E+05	0.2178327000E+05
	0.3345033680E+05	0.2176603320E+05
115	0.3279558551E+05	0.2208454449E+05
	0.3277514000E+05	0.2210499000E+05
	0.3279558551E+05	0.2208454449E+05
	0.3197297139E+05	0.2115201528E+05
	0.3195169334E+05	0.2117329333E+05
	0.3197297139E+05	0.2115201528E+05
	0.3145629691E+05	0.2128604309E+05
	0.3143290000E+05	0.2130944000E+05
116	0.3145629691E+05	0.2128604309E+05
	0.3093992604E+05	0.2141976729E+05
	0.3091410666E+05	0.2144558667E+05
	0.3093992604E+05	0.2141976729E+05
	0.2990401776E+05	0.1984725058E+05
	0.2982838334E+05	0.1992288500E+05
	0.2990401776E+05	0.1984725058E+05
	0.2913973576E+05	0.1947772924E+05
117	0.2893537000E+05	0.1968209500E+05
	0.2913973576E+05	0.1947772924E+05
	0.2844809835E+05	0.1903556331E+05
	0.2804235666E+05	0.1944130500E+05
	0.2844809835E+05	0.1903556331E+05
	0.2564625661E+05	0.1353491626E+05
	0.2523265002E+05	0.1394852285E+05
	0.2564625661E+05	0.1353491626E+05
120	0.2247102925E+05	0.9699429248E+04
	0.2204891000E+05	0.1012154850E+05
	0.2247102925E+05	0.9699429248E+04
	0.1929601606E+05	0.5863728068E+04
	0.1886516998E+05	0.6294574148E+04
	0.1929601606E+05	0.5863728068E+04
	0.1590008886E+05	-0.1944402864E+04
	0.1590008000E+05	-0.1944394000E+04
0.1590008886E+05	-0.1944402864E+04	
0.1590008000E+05	-0.1944394000E+04	
0.1590008000E+05	-0.1944394000E+04	
0.1590008000E+05	-0.1944394000E+04	
0.1590008886E+05	-0.1944402864E+04	

ELEMENT	PRC. STRESS I	PRC. STRESS II
120	0.1590008000E+05	-0.1944394000E+04
	0.1590008886E+05	-0.1944402864E+04
130	0.6214539014E+05	0.3527786581E+03
	0.6214539000E+05	0.3527788000E+03
	0.6214539014E+05	0.3527786581E+03
	0.6214539000E+05	0.3527788000E+03
	0.6214539000E+05	0.3527788000E+03
	0.6214539000E+05	0.3527788000E+03
	0.6214539014E+05	0.3527786581E+03
	0.6214539000E+05	0.3527788000E+03
	0.6214539014E+05	0.3527786581E+03

--- CROSS REFERENCE TABLE FOR SHELL ELEMENTS ---

SHELL ELT. NO.	SOLID ELT. NO.
100	1
101	2
102	3
103	4
104	5
105	6
106	7
107	8
110	1
111	2
112	3
113	4
114	5
115	6
116	7
117	8
120	8
130	1

--- CROSS REFERENCE TABLE FOR SOLID ELEMENTS ---

SOLID ELT. NO.	SHELL ELT. NOS.		
1	100	110	130
2	101	111	
3	102	112	
4	103	113	
5	104	114	
6	105	115	
7	106	116	
8	107	117	120

--- VOLUME AND TEMPERATURE OF EACH SOLID ELEMENT ---

ELEMENT NO.	VOLUME	AVE. TEMP.
1	0.5338E-03	0.7000E+02
2	0.1359E-02	0.7000E+02
3	0.1747E-02	0.7000E+02
4	0.2135E-02	0.7000E+02
5	0.2523E-02	0.7000E+02
6	0.2912E-02	0.7000E+02
7	0.6988E-02	0.7000E+02
8	0.3185E-01	0.7000E+02

--- AREA AND TEMPERATURE OF EACH SHELL ELEMENT ---

ELEMENT NO.	AREA	AVE. TEMP.
100	0.3600E-02	0.7000E+02
101	0.9163E-02	0.7000E+02
102	0.1178E-01	0.7000E+02
103	0.1440E-01	0.7000E+02
104	0.1702E-01	0.7000E+02
105	0.1963E-01	0.7000E+02
106	0.4712E-01	0.7000E+02
107	0.2148E+00	0.7000E+02
110	0.3600E-02	0.7000E+02
111	0.9163E-02	0.7000E+02
112	0.1178E-01	0.7000E+02
113	0.1440E-01	0.7000E+02
114	0.1702E-01	0.7000E+02
115	0.1963E-01	0.7000E+02
116	0.4712E-01	0.7000E+02
117	0.2148E+00	0.7000E+02
120	0.6381E-01	0.7000E+02
130	0.9817E-02	0.7000E+02

```

*****
*
*           ECHO OF MATERIAL CONTROL INPUT           *
*
*****

```

TITLE = SI3N4 SPECIMEN DATA FOR VOLUME FLAW ANALYSIS (REF. SWANK AND WILLIAMS)

300 = MATERIAL IDENTIFICATION NUMBER (MATID)

1 = CONTROL INDEX FOR VOLUME OR SURFACE FLAW ANALYSIS (ID4)
 1 : VOLUME
 2 : SURFACE

3 = CONTROL INDEX FOR EXPERIMENTAL DATA (ID1)
 1 : UNIFORM UNIAXIAL TENSILE SPECIMEN TEST DATA
 2 : FOUR-POINT BEND TEST DATA
 3 : DIRECT INPUT OF THE WEIBULL PARAMETERS, M AND SP
 (SHAPE PARAMETER AND SCALE PARAMETER)
 4 : CENSORED DATA FOR SUSPENDED ITEM ANALYSIS OF
 UNIFORM UNIAXIAL TENSILE SPECIMEN TEST DATA
 5 : CENSORED DATA FOR SUSPENDED ITEM ANALYSIS OF
 FOUR-POINT BEND TEST DATA

5 = CONTROL INDEX FOR VOLUME FRACTURE CRITERION (ID2V)
 1 : NORMAL STRESS FRACTURE CRITERION
 (SHEAR-INSENSITIVE CRACK)
 2 : MAXIMUM TENSILE STRESS CRITERION
 3 : COPLANAR STRAIN ENERGY RELEASE RATE CRITERION
 4 : WEIBULL PIA MODEL
 5 : SHETTY'S SEMI-EMPIRICAL CRITERION

2 = CONTROL INDEX FOR SHAPE OF VOLUME CRACKS (ID3V)
 1 : GRIFFITH CRACK
 2 : PENNY-SHAPED CRACK

0 = CONTROL INDEX FOR METHOD OF CALCULATING BATDORF CRACK DENSITY COEFFICIENT
 (K SUB B) FROM TEST DATA (K BAT)
 0 : SHEAR-INSENSITIVE METHOD (MODE I FRACTURE ASSUMED)
 1 : SHEAR-SENSITIVE METHOD (FRACTURE ASSUMED TO OCCUR
 ACCORDING TO THE FRACTURE CRITERION AND CRACK
 SHAPE SELECTED BY THE ID2 AND ID3 INDICES)

0.8000 = CONSTANT FOR SHETTY'S SEMI-EMPIRICAL FRACTURE CRITERION (C)
 $(K_I/K_{IC}) + ((K_{II} \text{ OR } K_{III}) / (C * K_{IC}))^2 = 1$
 OBSERVED VALUES RANGE FROM .8 TO 2. (REF. D. K. SHETTY)
 NOTE: AS C APPROACHES INFINITY PREDICTED FAILURE
 PROBABILITIES APPROACH NORMAL STRESS CRITERION

0.2190 = POISSON'S RATIO (PR)

```

XXXXXXXXXXXXXXXXXXXXXXXXXXXXXXXXXXXXXXXXXXXXXXXXXXXXXXXXXXXX
X
X          VOLUME FLAW PARAMETER ANALYSIS          X
X
XXXXXXXXXXXXXXXXXXXXXXXXXXXXXXXXXXXXXXXXXXXXXXXXXXXXXXXXXXXX

```

*** BATDORF MODEL --- CRACK ORIENTATION, CRACK SHAPE, AND FRACTURE CRITERION ARE CONSIDERED ***

--- TEMPERATURE DEPENDENT MATERIAL PARAMETERS FOR MATERIAL NUMBER 300

WEIBULL MODULUS (SHAPE PARAMETER), M (DIMENSIONLESS)
 NORMALIZED BATDORF CRACK DENSITY COEFFICIENT, K (DIMENSIONLESS)
 SCALE PARAMETER, SP (UNITS OF STRESS*VOLUME*(1/M))

TEMPERATURE	M	K	SP
70.0000	0.7650E+01	0.1630E+02	0.4580E+05

FRACTURE CRITERION = $(K_I/K_{Ic}) + ((K_{II} \text{ OR } K_{III}) / (C * K_{Ic}))^2 = 1$ WHERE C = 0.8000E+00
 CRACK SHAPE = PENNY-SHAPED CRACK

```
*****
*
*           ECHO OF MATERIAL CONTROL INPUT           *
*
*****
```

TITLE = SI3N4 SPECIMEN DATA FOR SURFACE FLAW ANALYSIS (REF. SWANK AND WILLIAMS)

300 = MATERIAL IDENTIFICATION NUMBER (MATID)

2 = CONTROL INDEX FOR VOLUME OR SURFACE FLAW ANALYSIS (ID4)

- 1 : VOLUME
- 2 : SURFACE

3 = CONTROL INDEX FOR EXPERIMENTAL DATA (ID1)

- 1 : UNIFORM UNIAXIAL TENSILE SPECIMEN TEST DATA
- 2 : FOUR-POINT BEND TEST DATA
- 3 : DIRECT INPUT OF THE WEIBULL PARAMETERS, M AND SP
(SHAPE PARAMETER AND SCALE PARAMETER)
- 4 : CENSORED DATA FOR SUSPENDED ITEM ANALYSIS OF
UNIFORM UNIAXIAL TENSILE SPECIMEN TEST DATA
- 5 : CENSORED DATA FOR SUSPENDED ITEM ANALYSIS OF
FOUR-POINT BEND TEST DATA

5 = CONTROL INDEX FOR SURFACE FRACTURE CRITERION (ID2S)

- 1 : NORMAL STRESS FRACTURE CRITERION
(SHEAR-INSENSITIVE CRACK)
- 3 : COPLANAR STRAIN ENERGY RELEASE RATE CRITERION
- 4 : WEIBULL PIA MODEL
- 5 : SHETTY'S SEMI-EMPIRICAL CRITERION

4 = CONTROL INDEX FOR SHAPE OF SURFACE CRACKS (ID3S)

- 1 : GRIFFITH CRACK
(ASSOCIATED WITH STRAIN ENERGY RELEASE RATE CRITERION`
(ASSOCIATED WITH SHETTY'S SEMI-EMPIRICAL CRITERION)
- 3 : GRIFFITH NOTCH
(ASSOCIATED WITH STRAIN ENERGY RELEASE RATE CRITERION)
(ASSOCIATED WITH SHETTY'S SEMI-EMPIRICAL CRITERION)
- 4 : SEMICIRCULAR CRACK
(ASSOCIATED WITH SHETTY'S SEMI-EMPIRICAL CRITERION)

0 = CONTROL INDEX FOR METHOD OF CALCULATING BATDORF CRACK DENSITY COEFFICIENT
(K SUB B) FROM TEST DATA (IKBAT)

- 0 : SHEAR-INSENSITIVE METHOD (MODE I FRACTURE ASSUMED)
- 1 : SHEAR-SENSITIVE METHOD (FRACTURE ASSUMED TO OCCUR
ACCORDING TO THE FRACTURE CRITERION AND CRACK
SHAPE SELECTED BY THE ID2 AND ID3 INDICES)

0.8000 = CONSTANT FOR SHETTY'S SEMI-EMPIRICAL FRACTURE CRITERION (C)

$(K_I/K_{IC}) + ((K_{II} \text{ OR } K_{III}) / (C * K_{IC}))^{*2} = 1$
OBSERVED VALUES RANGE FROM .8 TO 2. (REF. D. K. SHETTY)
NOTE: AS C APPROACHES INFINITY PREDICTED FAILURE
PROBABILITIES APPROACH NORMAL STRESS CRITERION

0.2190 = POISSON'S RATIO (PR)

```

*****
*
*           SURFACE FLAW PARAMETER ANALYSIS           *
*
*****

```

*** BATDORF MODEL --- CRACK ORIENTATION, CRACK SHAPE, AND FRACTURE CRITERION ARE CONSIDERED ***

--- TEMPERATURE DEPENDENT MATERIAL PARAMETERS FOR MATERIAL NUMBER 300

WEIBULL MODULUS (SHAPE PARAMETER), M (DIMENSIONLESS)
 NORMALIZED BATDORF CRACK DENSITY COEFFICIENT, K (DIMENSIONLESS)
 SCALE PARAMETER, SP (UNITS OF STRESS*AREA**(1/M))

TEMPERATURE	M	K	SP
70.0000	0.7650E+01	0.4986E+01	0.8789E+05

FRACTURE CRITERION = $(K_I/K_{IC}) + ((K_{II} \text{ OR } K_{III}) / (C * K_{IC}))^2 = 1$ WHERE $C = 0.8000E+00$
 CRACK SHAPE = SEMICIRCULAR CRACK

```

*****
*                                     *
*          VOLUME FLAW RELIABILITY ANALYSIS          *
*                                     *
*****

```

NOTE: THE ELEMENT SURVIVAL AND FAILURE PROBABILITIES TAKE INTO ACCOUNT THE NUMBER OF SEGMENTS (NS).

--- ELEMENT CALCULATIONS ---

ELEMENT	MATID	SURVIVAL PROB.	FAILURE PROB.	RISK RUP. INT.	M	K	SP
1	300	0.5383D+00	0.4617D+00	0.4834D+02	0.7650D+01	0.1630D+02	0.4580D+05
2	300	0.7048D+00	0.2952D+00	0.1073D+02	0.7650D+01	0.1630D+02	0.4580D+05
3	300	0.8939D+00	0.1061D+00	0.2674D+01	0.7650D+01	0.1630D+02	0.4580D+05
4	300	0.9390D+00	0.6097D-01	0.1228D+01	0.7650D+01	0.1630D+02	0.4580D+05
5	300	0.9579D+00	0.4209D-01	0.7101D+00	0.7650D+01	0.1630D+02	0.4580D+05
6	300	0.9688D+00	0.3116D-01	0.4530D+00	0.7650D+01	0.1630D+02	0.4580D+05
7	300	0.9532D+00	0.4682D-01	0.2859D+00	0.7650D+01	0.1630D+02	0.4580D+05
8	300	0.9695D+00	0.3053D-01	0.4056D-01	0.7650D+01	0.1630D+02	0.4580D+05

SORTED MAXIMUM RISK OF RUPTURE INTENSITIES AND CORRESPONDING ELEMENT NUMBERS

ELEMENT	RISK RUP. INT.
1	0.4834D+02
2	0.1073D+02
3	0.2674D+01
4	0.1228D+01
5	0.7101D+00
6	0.4530D+00
7	0.2859D+00
8	0.4056D-01

FOR F.E. MODEL VOLUME --- PROBABILITY OF FAILURE = 0.7269D+00
 PROBABILITY OF SURVIVAL = 0.2731D+00

```

*****
*
* SURFACE FLAW RELIABILITY ANALYSIS
*
*****

```

NOTE: THE ELEMENT SURVIVAL AND FAILURE PROBABILITIES TAKE INTO ACCOUNT THE NUMBER OF SEGMENTS (NS).

--- ELEMENT CALCULATIONS ---

ELEMENT	MATID	SURVIVAL PROB.	FAILURE PROB.	RISK	RUP.	INT.	M	K	SP
100	300	0.9926D+00	0.7415D-02	0.8614D-01	0.7650D+01	0.4986D+01	0.8789D+05		
101	300	0.9960D+00	0.3953D-02	0.1801D-01	0.7650D+01	0.4986D+01	0.8789D+05		
102	300	0.9986D+00	0.1358D-02	0.4806D-02	0.7650D+01	0.4986D+01	0.8789D+05		
103	300	0.9992D+00	0.7836D-03	0.2268D-02	0.7650D+01	0.4986D+01	0.8789D+05		
104	300	0.9995D+00	0.5480D-03	0.1342D-02	0.7650D+01	0.4986D+01	0.8789D+05		
105	300	0.9996D+00	0.4060D-03	0.8617D-03	0.7650D+01	0.4986D+01	0.8789D+05		
106	300	0.9995D+00	0.5364D-03	0.4744D-03	0.7650D+01	0.4986D+01	0.8789D+05		
107	300	0.9996D+00	0.3926D-03	0.7618D-04	0.7650D+01	0.4986D+01	0.8789D+05		
110	300	0.9926D+00	0.7415D-02	0.8614D-01	0.7650D+01	0.4986D+01	0.8789D+05		
111	300	0.9960D+00	0.3953D-02	0.1801D-01	0.7650D+01	0.4986D+01	0.8789D+05		
112	300	0.9986D+00	0.1358D-02	0.4806D-02	0.7650D+01	0.4986D+01	0.8789D+05		
113	300	0.9992D+00	0.7836D-03	0.2268D-02	0.7650D+01	0.4986D+01	0.8789D+05		
114	300	0.9995D+00	0.5480D-03	0.1342D-02	0.7650D+01	0.4986D+01	0.8789D+05		
115	300	0.9996D+00	0.4060D-03	0.8617D-03	0.7650D+01	0.4986D+01	0.8789D+05		
116	300	0.9995D+00	0.5364D-03	0.4744D-03	0.7650D+01	0.4986D+01	0.8789D+05		
117	300	0.9996D+00	0.3926D-03	0.7618D-04	0.7650D+01	0.4986D+01	0.8789D+05		
120	300	0.1000D+01	0.8979D-05	0.5863D-05	0.7650D+01	0.4986D+01	0.8789D+05		
130	300	0.9607D+00	0.3926D-01	0.1700D+00	0.7650D+01	0.4986D+01	0.8789D+05		

SORTED MAXIMUM RISK OF RUPTURE INTENSITIES AND CORRESPONDING ELEMENT NUMBERS

ELEMENT	RISK RUP. INT.
130	0.1700D+00
100	0.8614D-01
110	0.8614D-01
101	0.1801D-01
111	0.1801D-01
102	0.4806D-02
112	0.4806D-02
103	0.2268D-02
113	0.2268D-02
104	0.1342D-02
114	0.1342D-02
105	0.8617D-03
115	0.8617D-03
106	0.4744D-03
116	0.4744D-03

FOR F.E. MODEL SURFACE --- PROBABILITY OF FAILURE = 0.6846D-01
PROBABILITY OF SURVIVAL = 0.9315D+00

```

*****
*
* OVERALL COMPONENT STATISTICS
*
*****

```

COMPONENT FAILURE PROBABILITY = 0.7456D+00
COMPONENT SURVIVAL PROBABILITY = 0.2544D+00

Example 3—Statistical Material Parameter Estimation

To validate the methods used to estimate statistical material parameters, we compared results from the fracture of four-point bend bars broken at NASA Lewis and analyzed by CARES with results independently obtained by Bruckner-Foit and Munz (ref. 57) for the International Energy Agency (IEA), Annex II, Subtask 4 (ref. 58). The IEA Annex II agreement is focused on cooperative research and development among the United States, West Germany, and Sweden in the areas of structural ceramics. Subtask 4 of the agreement addresses mechanical property measurement methods with initial research concentrating solely on four-point flexure testing. Three different materials were analyzed, namely a hot isostatic pressed (HIPped) silicon carbide (SiC) from Elektroschmelzwerke Kempten (ESK), West Germany, a HIPped silicon nitride (Si_3N_4) from ASEA CERAMA, Sweden; and a sintered silicon nitride from GTE WESGO, USA, although only results from the ESK and ASEA materials are discussed herein.

In November 1986, 400 HIPped SiC flexure bars from West Germany were distributed by Oak Ridge National Laboratory (ORNL) (Oakridge, Tennessee) to the five participating U.S. laboratories, including NASA Lewis. The bars were fractured at these laboratories and the fracture stress data sets were returned to ORNL as complete data without censoring for different failure modes. Shortly thereafter, 400 Si_3N_4 bars from Sweden were also received by ORNL and subsequently distributed to the same U.S. laboratories for fracture testing. Again, the fracture stress data sets were returned to ORNL as complete samples. The number of specimens of a particular material given to each U.S. laboratory was 80. The specimens had cross-sectional dimensions of 3.5 mm (0.138 in.) in width and 4.5 mm (0.177 in.) in height. The specimens were tested in four-point bending with an outer span of 40 mm (1.57 in.) and an inner span of 20 mm (0.787 in.). The nominal loading rate was 0.5 mm/min (0.020 in./min), and the testing temperature was approximately 20 °C (68 °F).

Details of the statistical analyses of these data sets are given in references 57 and 58. The results of the 80 silicon carbide flexure bars tested at NASA Lewis, which are shown in table IX, were analyzed with the CARES code to calculate the maximum likelihood estimates (MLE's) of the Weibull parameters. The Weibull parameter values from CARES, summarized in table X, match the predictions from reference 57 reasonably well. The SiC fracture data are plotted in figure 21 along with the proposed Weibull line and the Kanofsky-Srinivasan 90-percent confidence bands. Since all of the data are within the 90-percent bands and the goodness-of-fit significance levels are high, it is concluded that the fracture data show good Weibull behavior.

ASEA CERAMA HIPped Si_3N_4 bars (ref. 58) from Sweden were also fractured at NASA Lewis, and subsequently, the statistical material parameters were estimated with CARES by using the maximum likelihood method. A comparison of the Si_3N_4 results with those in reference 57 is also shown in

TABLE IX.—EXTREME FIBER FRACTURE STRESSES OF ESK HIPped SILICON CARBIDE (SiC) BARS

Flexure bar	Strength, MPa	Flexure bar	Strength, MPa
1	281.2	41	516.2
2	291.0	42	519.8
3	358.2	43	527.6
4	385.4	44	530.7
5	389.0	45	530.7
6	390.8	46	545.7
7	391.8	47	548.8
8	402.8	48	552.7
9	412.5	49	559.6
10	413.3	50	562.4
11	413.9	51	563.3
12	417.8	52	566.1
13	418.2	53	566.5
14	426.9	54	570.1
15	437.6	55	572.8
16	440.0	56	575.0
17	441.0	57	576.1
18	442.5	58	580.0
19	443.8	59	582.6
20	444.9	60	588.0
21	446.2	61	588.6
22	451.5	62	591.0
23	452.1	63	591.0
24	452.7	64	593.3
25	470.4	65	598.7
26	474.1	66	599.6
27	475.5	67	610.0
28	475.5	68	612.7
29	479.2	69	619.9
30	483.5	70	619.9
31	484.8	71	622.2
32	486.2	72	622.3
33	488.6	73	640.5
34	492.5	74	649.0
35	493.2	75	657.2
36	496.0	76	660.0
37	505.7	77	664.3
38	511.9	78	673.5
39	512.5	79	673.9
40	513.8	80	725.3

table X. Agreement between estimates from the two sources is excellent. When the 80 ASEA silicon nitride bars were analyzed by the CARES code as a complete sample, the significance levels of 54 and 35 percent from the Kolmogorov-Smirnov and Anderson-Darling goodness-of-fit tests, respectively, were relatively low, indicating a questionable fit to the proposed Weibull distribution. The lower significance level for the Anderson-Darling test indicated greater deviation occurring in the low strength region of the distribution. From the outlier test included in the CARES code analysis package, the highest strength fracture stress was detected to be an outlier at the 1-percent significance level. Several of the lower strengths were flagged as outliers at various significance levels

TABLE X.—WEIBULL PARAMETERS, KOLMOGOROV-SMIRNOV, AND ANDERSON-DARLING TEST RESULTS FOR FOUR-POINT BEND BAR FRACTURE DATA DETERMINED BY THE MAXIMUM LIKELIHOOD METHOD

[All estimates are biased estimates; 80 complete samples per material.]

Material type	Source of data	Shape parameter, \hat{m}	90-percent confidence limits on \hat{m}		Characteristic strength $\hat{\sigma}_0$, MPa	90-percent confidence limits on $\hat{\sigma}_0$, MPa		K-S test statistic, D	K-S test significance level, α , percent	A-D test significance level, α , percent
			Upper	Lower		Upper	Lower			
SiC (ESK)	CARES	6.48	7.38	5.52	556	573	539	0.070	83	86
SiC (ESK)	Ref. 57	6.59	7.65	5.61	556	574	539	.063	(a)	(a)
Si ₃ N ₄ (ASEA)	CARES	13.39	15.25	11.42	686	696	676	.0901	54	35
Si ₃ N ₄ (ASEA)	Ref. 57	13.40	15.3	11.4	686	696	676	.088	(a)	(a)

^aNot available.

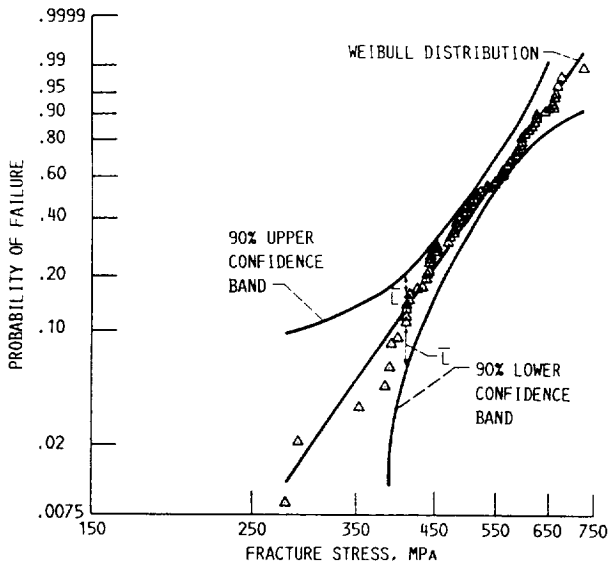

Figure 21.—90-percent confidence bands about the Weibull line for ESK HIPped silicon carbide (SiC). (Fracture stress data generated at NASA Lewis; not all data points shown; $\bar{L} = 0.0829$.)

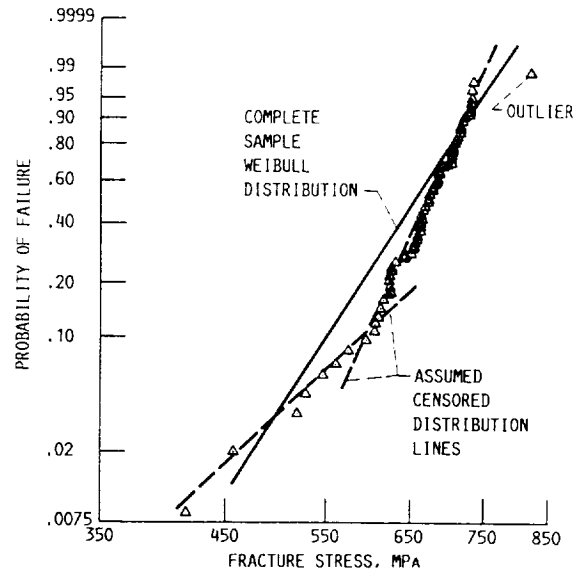

Figure 22.—Complete sample, assumed censored sample Weibull distributions, and outlier in ASEA CERAMA HIPped silicon nitride (Si₃N₄). (Fracture stress data generated at NASA Lewis; not all data points shown.)

(1, 5, or 10 percent). Figure 22 shows a Weibull plot of the data. From the figure it appears that the data are bimodal with an outlier point at the highest strength.

Because of the observed trends, the data were re-analyzed assuming a censored distribution and removing the highest strength outlier point ($\sigma_f = 817.2$ MPa (1.185×10^5 psi)) as bad data. Although it is possible that both failure modes were surface induced, for the sake of this example it is assumed that the low-strength failures were predominantly due to volume flaws and that the high-strength specimens fractured predominantly because of surface flaws. Since results from fractography of the individual specimens to identify the various failure modes were not available, the fracture origins had to be arbitrarily assigned prior to parameter estimation. Note that identifying individual specimen flaw origins is especially important for small sample sizes where a plot of the data does

not yield clear trends. However, for the NASA Lewis Si₃N₄ data, the sample size was large, and clear trends could be observed, although extra care would be required to determine if the trends were surface flaw or volume flaw based. From inspection of figure 22, we decided to assign the lowest nine strengths as due to volume flaws and the remainder as due to surface flaws. An input file for CARES was prepared and is reproduced at the end of this example along with the CARES output. The cracks were arbitrarily assumed to be Griffith cracks, and the total strain energy release rate fracture criterion was used. This assumption was used only in the calculation of k_{BS} and k_{BV} . The K-S significance level increased from 0.54 to 0.68, and the A-D significance level increased from 0.35 to 0.58. This improvement supports the initial assumption of bimodal behavior. The value of \hat{m} changed from 13.4 for the complete sample to $\hat{m}_S = 22.8$ and $\hat{m}_V = 4.13$. The value

of $\hat{\sigma}_\theta$ changed from 686 MPa (9.950×10^4 psi) for the complete sample to $\hat{\sigma}_{\theta S} = 692$ MPa (1.004×10^5 psi) and $\hat{\sigma}_{\theta V} = 1128$ MPa (1.636×10^5 psi) for the surface and volume flaw distributions, respectively. Further improvements in the goodness-of-fit scores may be gained by correctly identifying the location of fracture origins.

From equation (85) the normalized Batdorf crack density coefficient for volume flaws is $(m_V + 1) = 4.13 + 1 = 5.13$, and from equation (75) the scale parameter $\sigma_{\theta V}$ is 17.9 MPa(m)^{3.4.13} (3.742×10^4 psi(in.)^{3.4.13}). For surface flaws the normalized Batdorf crack density coefficient is 6.05, whereas $\sigma_{\theta S}$ calculated by using equation (90a) is 461.3 MPa(m)^{2.22.8} (9.234×10^4 psi(in.)^{2.22.8}).

For the Si₃N₄ fracture data from NASA Lewis, we have obtained goodness-of-fit significance levels as high as 0.78

and 0.88 for the K-S and A-D tests, respectively, by assuming a particular bimodal flaw distribution. For this case, 13 volume flaws were assumed, and the MLE's were $\hat{m}_S = 21.0$, $\hat{m}_V = 6.79$, $\hat{\sigma}_{\theta S} = 693$ MPa (1.005×10^5 psi), and $\hat{\sigma}_{\theta V} = 876$ MPa (1.271×10^5 psi). The 13 volume flaws did not correspond to the 13 lowest fracture strengths. On the basis of these goodness-of-fit scores, it is concluded that the data show good bimodal Weibull behavior.

It should be noted from figure 22 that the assumed volume flaw distribution dominates the failure response at low probabilities of failure. Therefore, in component design, it is essential to properly account for competing failure modes; otherwise nonconservative design predictions may result.

CARES TEMPLET INPUT FILE

*
* RELIABILITY PREDICTION FOR BRITTLE MATERIAL STRUCTURES *
* --- FAST FRACTURE STATISTICS --- *
* *

MASTER CONTROL INPUT

TITLE : PROBLEM TITLE (ECHOED IN CARES OUTPUT)

EXAMPLE PROBLEM 3 : STATISTICAL MATERIAL PARAMETER ESTIMATION

NE : CONTROL INDEX FOR FINITE ELEMENT POSTPROCESSING

(DEFAULT: NE = 0)
0 0 : EXPERIMENTAL DATA ANALYSIS ONLY

1 : MSC/NASTRAN ANALYSIS
2 : ANSYS ANALYSIS

NMATS : NO. OF MATERIALS FOR SURFACE FLAW ANALYSIS

(NMATS+NMATV < 101)
01 (DEFAULT: NMATS = 0)

NMATV : NO. OF MATERIALS FOR VOLUME FLAW ANALYSIS

(NMATS+NMATV < 101)
01 (DEFAULT: NMATV = 0)

IPRINT : CONTROL INDEX FOR STRESS OUTPUT

(DEFAULT: IPRINT = 0)
1 0 : DO NOT PRINT ELEMENT STRESSES AND/OR FRACTURE DATA

1 : PRINT ELEMENT STRESSES AND/OR FRACTURE DATA

NGP : NO. OF GAUSSIAN QUADRATURE POINTS (15 OR 30)

(DEFAULT: NGP = 15)
30

\$ENDX : END OF MASTER CONTROL INPUT

MATERIAL CONTROL INPUT

TITLE : MATERIAL TITLE (ECHOED IN CARES OUTPUT)

SI3N4 SPECIMEN DATA FROM ASEA CERAMA FOR VOLUME FLAW ANALYSIS

MATID : MATERIAL IDENTIFICATION NO. FROM THE FINITE ELEMENT

 0000001 MATERIAL PROPERTY CARD (IF POSTPROCESSING IS NOT
 ----- BEING PERFORMED THIS ENTRY SHOULD BE SOME UNIQUE NO.)
 ----- (NO DEFAULT)

ID1 : CONTROL INDEX FOR EXPERIMENTAL DATA
 ----- (NO DEFAULT)
 5 1 : UNIFORM UNIAXIAL TENSILE SPECIMEN TEST DATA
 ----- 2 : FOUR-POINT BEND TEST DATA
 3 : DIRECT INPUT OF THE WEIBULL PARAMETERS, M AND SP
 (SHAPE PARAMETER AND SCALE PARAMETER)
 4 : CENSORED DATA FOR SUSPENDED ITEM ANALYSIS OF
 UNIFORM UNIAXIAL TENSILE SPECIMEN TEST DATA
 5 : CENSORED DATA FOR SUSPENDED ITEM ANALYSIS OF
 FOUR-POINT BEND TEST DATA

ID4 : CONTROL INDEX FOR VOLUME OR SURFACE FLAW ANALYSIS
 ----- (NO DEFAULT)
 1 1 : VOLUME
 ----- 2 : SURFACE

ID2V : CONTROL INDEX FOR VOLUME FRACTURE CRITERION
 ----- (NO DEFAULT)
 3 1 : NORMAL STRESS FRACTURE CRITERION
 ----- (SHEAR-INSENSITIVE CRACK)
 2 : MAXIMUM TENSILE STRESS CRITERION
 3 : COPLANAR STRAIN ENERGY RELEASE RATE CRITERION
 (G SUB T)
 4 : WEIBULL PIA MODEL
 5 : SHETTY'S SEMI-EMPIRICAL CRITERION

ID3V : CONTROL INDEX FOR SHAPE OF VOLUME CRACKS
 ----- (NO DEFAULT)
 1 1 : GRIFFITH CRACK
 ----- 2 : PENNY-SHAPED CRACK

IKBAT : CONTROL INDEX FOR METHOD OF CALCULATING BATDORF CRACK
 ----- DENSITY COEFFICIENT (K SUB B) FROM TEST DATA
 1 (DEFAULT: IKBAT = 0)
 ----- 0 : SHEAR-INSENSITIVE METHOD (MODE I FRACTURE ASSUMED)
 1 : SHEAR-SENSITIVE METHOD (FRACTURE ASSUMED TO OCCUR
 ACCORDING TO THE FRACTURE CRITERION AND CRACK SHAPE
 SELECTED BY THE ID2 AND ID3 INDICES)

PR : POISSON'S RATIO
 ----- (DEFAULT: PR = 0.25)
 00000.2500

MLORLE : CONTROL INDEX FOR METHOD OF CALCULATING WEIBULL
 ----- PARAMETERS FROM THE EXPERIMENTAL FRACTURE DATA
 0 (DEFAULT: MLORLE = 0)
 ----- 0 : MAXIMUM LIKELIHOOD
 1 : LEAST-SQUARES LINEAR REGRESSION

DH : HEIGHT OF THE FOUR-POINT BEND BAR
(NO DEFAULT)
0000.00350

DL1 : OUTER LOAD SPAN OF THE FOUR-POINT BEND BAR
(NO DEFAULT)
0000.04000

DL2 : INNER LOAD SPAN OF THE FOUR-POINT BEND BAR
(NO DEFAULT)
0000.02000

DW : WIDTH OF THE FOUR-POINT BEND BAR
(NO DEFAULT)
0000.00450

\$ENDM : END OF TEMPERATURE INDEPENDENT MATERIAL CONTROL INPUT

TEMPERATURE DEPENDENT MATERIAL CONTROL INPUT DATA
FOR THE ABOVE MATERIAL

!!
PLEASE NOTE THE FOLLOWING:
1. TEMPERATURE DEPENDENT DATA SETS MUST BE ARRANGED IN ASCENDING ORDER
ACCORDING TO TEMPERATURE.
2. FRACTURE STRESSES FOR A GIVEN TEMPERATURE CAN BE INPUT IN
ARBITRARY ORDER.
3. MAXIMUM NUMBER OF TEMPERATURE SETS IS 20.
4. MAXIMUM NUMBER OF FRACTURE SPECIMENS PER TEMPERATURE IS 200.
5. REGARDLESS OF THE FRACTURE ORIGIN LOCATION, THE FRACTURE STRESS
INPUT VALUE IS THE EXTREME FIBER STRESS WITHIN THE INNER LOAD SPAN
OF THE MOR BAR.
!!

TDEG : TEMPERATURE OF THIS SET
00070.0000

NUT : NUMBER OF FRACTURE SPECIMENS AT THIS TEMPERATURE
079

MOR : S-URFACE, V-OLUME, OR U-NKNOWN FLAW AND RESPECTIVE STRESS

SVV	0.6257900000E+03	0.6034700000E+03	0.5272300000E+03
SSS	0.6911000000E+03	0.6831100000E+03	0.6854900000E+03
SSS	0.6950100000E+03	0.6721000000E+03	0.6569200000E+03

SSS	0.6616800000E+03	0.7270500000E+03	0.7259500000E+03
SSS	0.6707500000E+03	0.7029700000E+03	0.6114900000E+03
SSS	0.6401800000E+03	0.7045300000E+03	0.7254400000E+03
VSS	0.5725000000E+03	0.6251400000E+03	0.6741300000E+03
SSS	0.6597400000E+03	0.6501400000E+03	0.7164300000E+03
SSS	0.6621400000E+03	0.6997700000E+03	0.6645400000E+03
SSS	0.7156300000E+03	0.6045300000E+03	0.6664400000E+03
VVS	0.5605800000E+03	0.4159200000E+03	0.6214600000E+03
SSS	0.6311300000E+03	0.7254400000E+03	0.6940100000E+03
SSS	0.6770800000E+03	0.7251700000E+03	0.7126000000E+03
SSS	0.7156300000E+03	0.7173200000E+03	0.7029200000E+03
VSS	0.5457700000E+03	0.7323300000E+03	0.6717300000E+03
SSS	0.6837300000E+03	0.6144200000E+03	0.6636100000E+03
SSS	0.6490400000E+03	0.6867500000E+03	0.7157700000E+03
SSS	0.7044700000E+03	0.6570300000E+03	0.6641400000E+03
SSS	0.6215900000E+03	0.7165100000E+03	0.7028800000E+03
SSS	0.6515900000E+03	0.7028810000E+03	0.7060500000E+03
SSV	0.7100500000E+03	0.6550600000E+03	0.4583600000E+03
SSS	0.6688200000E+03	0.6597400000E+03	0.6426400000E+03
SSS	0.6093200000E+03	0.6711600000E+03	0.6768300000E+03
SSS	0.6210000000E+03	0.6870000000E+03	0.6221500000E+03
SVS	0.6620500000E+03	0.5950400000E+03	0.6783500000E+03
SSS	0.7286600000E+03	0.6223700000E+03	0.6798500000E+03
V	0.5199000000E+03		

-----*-----*-----*-----*-----*

END OF DATA FOR THE ABOVE TEMPERATURE

\$ENDT : END OF DATA FOR THE ABOVE MATERIAL

MATERIAL CONTROL INPUT

TITLE : MATERIAL TITLE (ECHOED IN CARES OUTPUT)

SI3N4 SPECIMEN DATA FROM ASEA CERAMA FOR SURFACE FLAW ANALYSIS

MATID : MATERIAL IDENTIFICATION NO. FROM THE FINITE ELEMENT

MATERIAL PROPERTY CARD (IF POSTPROCESSING IS NOT
0000002 BEING PERFORMED THIS ENTRY SHOULD BE SOME UNIQUE NO.)

(NO DEFAULT)

ID1 : CONTROL INDEX FOR EXPERIMENTAL DATA

(NO DEFAULT)
5

1 : UNIFORM UNIAXIAL TENSILE SPECIMEN TEST DATA
2 : FOUR-POINT BEND TEST DATA
3 : DIRECT INPUT OF THE WEIBULL PARAMETERS, M AND SP
(SHAPE PARAMETER AND SCALE PARAMETER)
4 : CENSORED DATA FOR SUSPENDED ITEM ANALYSIS OF
UNIFORM UNIAXIAL TENSILE SPECIMEN TEST DATA
5 : CENSORED DATA FOR SUSPENDED ITEM ANALYSIS OF
FOUR-POINT BEND TEST DATA

ID4 : CONTROL INDEX FOR VOLUME OR SURFACE FLAW ANALYSIS

 (NO DEFAULT)
 2 1 : VOLUME

 2 : SURFACE

ID2S : CONTROL INDEX FOR SURFACE FRACTURE CRITERION

 (NO DEFAULT)
 3 1 : NORMAL STRESS FRACTURE CRITERION

 (SHEAR-INSENSITIVE CRACK)
 3 : COPLANAR STRAIN ENERGY RELEASE RATE CRITERION
 (G SUB T)
 4 : WEIBULL PIA MODEL
 5 : SHETTY'S SEMI-EMPIRICAL CRITERION

ID3S : CONTROL INDEX FOR SHAPE OF SURFACE CRACKS

 (NO DEFAULT)
 1 1 : GRIFFITH CRACK

 (ASSOCIATED WITH STRAIN ENERGY RELEASE RATE CRIT.)
 (ASSOCIATED WITH SHETTY'S SEMI-EMPIRICAL CRITERION)
 3 : GRIFFITH NOTCH
 (ASSOCIATED WITH STRAIN ENERGY RELEASE RATE CRIT.)
 (ASSOCIATED WITH SHETTY'S SEMI-EMPIRICAL CRITERION)
 4 : SEMICIRCULAR CRACK
 (ASSOCIATED WITH SHETTY'S SEMI-EMPIRICAL CRITERION)

IKBAT : CONTROL INDEX FOR METHOD OF CALCULATING BATDORF CRACK

 DENSITY COEFFICIENT (K SUB B) FROM TEST DATA
 1 (DEFAULT: IKBAT = 0)

 0 : SHEAR-INSENSITIVE METHOD (MODE I FRACTURE ASSUMED)
 1 : SHEAR-SENSITIVE METHOD (FRACTURE ASSUMED TO OCCUR
 ACCORDING TO THE FRACTURE CRITERION AND CRACK SHAPE
 SELECTED BY THE ID2 AND ID3 INDICES)

PR : POISSON'S RATIO

 (DEFAULT: PR = 0.25)
 0000.2500

MLORLE : CONTROL INDEX FOR METHOD OF CALCULATING WEIBULL

 PARAMETERS FROM THE EXPERIMENTAL FRACTURE DATA
 0 (DEFAULT: MLORLE = 0)

 0 : MAXIMUM LIKELIHOOD
 1 : LEAST-SQUARES LINEAR REGRESSION

DH : HEIGHT OF THE FOUR-POINT BEND BAR

 (NO DEFAULT)
 0000.00350

DL1 : OUTER LOAD SPAN OF THE FOUR-POINT BEND BAR

 (NO DEFAULT)
 0000.04000

DL2 : INNER LOAD SPAN OF THE FOUR-POINT BEND BAR

 (NO DEFAULT)
0000.02000

DW : WIDTH OF THE FOUR-POINT BEND BAR

 (NO DEFAULT)
0000.00450

\$ENDM : END OF TEMPERATURE INDEPENDENT MATERIAL CONTROL INPUT

TEMPERATURE DEPENDENT MATERIAL CONTROL INPUT DATA
FOR THE ABOVE MATERIAL

!!
PLEASE NOTE THE FOLLOWING:

1. TEMPERATURE DEPENDENT DATA SETS MUST BE ARRANGED IN ASCENDING ORDER ACCORDING TO TEMPERATURE.
2. FRACTURE STRESSES FOR A GIVEN TEMPERATURE CAN BE INPUT IN ARBITRARY ORDER.
3. MAXIMUM NUMBER OF TEMPERATURE SETS IS 20.
4. MAXIMUM NUMBER OF FRACTURE SPECIMENS PER TEMPERATURE IS 200.
5. REGARDLESS OF THE FRACTURE ORIGIN LOCATION, THE FRACTURE STRESS INPUT VALUE IS THE EXTREME FIBER STRESS WITHIN THE INNER LOAD SPAN OF THE MOR BAR.

!!

TDEG : TEMPERATURE OF THIS SET

00070.0000

NUT : NUMBER OF FRACTURE SPECIMENS AT THIS TEMPERATURE

079

MOR : S-URFACE, V-OLUME, OR U-NKNOWN FLAW AND RESPECTIVE STRESS
-----*-----*-----*-----*-----*

SVV	0.6257900000E+03	0.6034700000E+03	0.5272300000E+03
SSS	0.6911000000E+03	0.6831100000E+03	0.6854900000E+03
SSS	0.6950100000E+03	0.6721000000E+03	0.6569200000E+03
SSS	0.6616800000E+03	0.7270500000E+03	0.7259500000E+03
SSS	0.6707500000E+03	0.7029700000E+03	0.6114900000E+03
SSS	0.6401800000E+03	0.7045300000E+03	0.7254400000E+03
VSS	0.5725000000E+03	0.6251400000E+03	0.6741300000E+03
SSS	0.6597400000E+03	0.6501400000E+03	0.7164300000E+03
SSS	0.6621400000E+03	0.6997700000E+03	0.6645400000E+03
SSS	0.7156300000E+03	0.6045300000E+03	0.6664400000E+03
VVS	0.5605800000E+03	0.4159200000E+03	0.6214600000E+03
SSS	0.6311300000E+03	0.7254400000E+03	0.6940100000E+03
SSS	0.6770800000E+03	0.7251700000E+03	0.7126000000E+03

SSS 0.7156300000E+03 0.7173200000E+03 0.7029200000E+03
VSS 0.5457700000E+03 0.7323300000E+03 0.6717300000E+03
SSS 0.6837300000E+03 0.6144200000E+03 0.6636100000E+03
SSS 0.6490400000E+03 0.6867500000E+03 0.7157700000E+03
SSS 0.7044700000E+03 0.6570300000E+03 0.6641400000E+03
SSS 0.6215900000E+03 0.7165100000E+03 0.7028800000E+03
SSS 0.6515900000E+03 0.7028810000E+03 0.7060500000E+03
SSV 0.7100500000E+03 0.6550600000E+03 0.4583600000E+03
SSS 0.6688200000E+03 0.6597400000E+03 0.6426400000E+03
SSS 0.6093200000E+03 0.6711600000E+03 0.6768300000E+03
SSS 0.6210000000E+03 0.6870000000E+03 0.6221500000E+03
SVS 0.6620500000E+03 0.5950400000E+03 0.6783500000E+03
SSS 0.7286600000E+03 0.6223700000E+03 0.6798500000E+03
V 0.5199000000E+03

-----*-----*-----*-----*-----*

END OF DATA FOR THE ABOVE TEMPERATURE

\$ENDT : END OF DATA FOR THE ABOVE MATERIAL

CARES2 OUTPUT FILE

```

@@@@@@@@@@@@@@@@@@@@@@@@@@@@@@@@@@@@@@@@@@@@@@@@@@@@@@@@@@@@@@@@@@@@@@@@@@@@@@@@@@@@
@@@@@@@@@@@@@@@@@@@@@@@@@@@@@@@@@@@@@@@@@@@@@@@@@@@@@@@@@@@@@@@@@@@@@@@@@@@@@@@@@@@@
@@
@@
@@
@@          CCCCCC          A          RRRRRRRRR      EEEEEEEEE     SSSSSSS
@@         C          C          A A          R          R      E          S          S
@@        C          C          A  A          R          R      E          S          S
@@       C          C          A   A          RRRRRRRRR    EEEEEEE     SSSSSSS
@@      C          C          AAAAAA          R          R      E          S          S
@@     C          C          A          A          R          R      E          S          S
@@    CCCCCC          A          A          R          R      EEEEEEEEE     SSSSSSS
@@
@@
@@
@@          CERAMICS ANALYSIS AND RELIABILITY EVALUATION OF STRUCTURES
@@
@@@@@@@@@@@@@@@@@@@@@@@@@@@@@@@@@@@@@@@@@@@@@@@@@@@@@@@@@@@@@@@@@@@@@@@@@@@@@@@@@@@@
@@@@@@@@@@@@@@@@@@@@@@@@@@@@@@@@@@@@@@@@@@@@@@@@@@@@@@@@@@@@@@@@@@@@@@@@@@@@@@@@@@@@

```

```

*****
*
*          ECHO OF MASTER CONTROL INPUT          *
*
*****

```

- TITLE = EXAMPLE PROBLEM 3 : STATISTICAL MATERIAL PARAMETER ESTIMATION

- 0 = CONTROL INDEX FOR FINITE ELEMENT POSTPROCESSING (NE)
 - 0 : EXPERIMENTAL DATA ANALYSIS ONLY
 - 1 : MSC/NASTRAN ANALYSIS
 - 2 : ANSYS ANALYSIS

- 1 = NUMBER OF MATERIALS FOR SURFACE FLAW ANALYSIS (NMATS)

- 1 = NUMBER OF MATERIALS FOR VOLUME FLAW ANALYSIS (NMATV)

- 30 = NUMBER OF GAUSSIAN QUADRATURE POINTS, EITHER 15 OR 30 (NGP)

- 1 = CONTROL INDEX FOR STRESS OUTPUT (IPRINT)
 - 0 : DO NOT PRINT ELEMENT STRESSES AND/OR FRACTURE DATA
 - 1 : PRINT ELEMENT STRESSES AND/OR FRACTURE DATA

```

*****
*
*          ECHO OF MATERIAL CONTROL INPUT          *
*
*****

```

TITLE = SI3N4 SPECIMEN DATA FROM ASEA CERAMA FOR VOLUME FLAW ANALYSIS

1 = MATERIAL IDENTIFICATION NUMBER (MATID)

1 = CONTROL INDEX FOR VOLUME OR SURFACE FLAW ANALYSIS (ID4)
 1 : VOLUME
 2 : SURFACE

0 = CONTROL INDEX FOR METHOD OF CALCULATING WEIBULL PARAMETERS FROM THE EXPERIMENTAL FRACTURE DATA (MLORLE)
 0 : MAXIMUM LIKELIHOOD
 1 : LEAST-SQUARES LINEAR REGRESSION

5 = CONTROL INDEX FOR EXPERIMENTAL DATA (ID1)
 1 : UNIFORM UNIAXIAL TENSILE SPECIMEN TEST DATA
 2 : FOUR-POINT BEND TEST DATA
 3 : DIRECT INPUT OF THE WEIBULL PARAMETERS, M AND SP (SHAPE PARAMETER AND SCALE PARAMETER)
 4 : CENSORED DATA FOR SUSPENDED ITEM ANALYSIS OF UNIFORM UNIAXIAL TENSILE SPECIMEN TEST DATA
 5 : CENSORED DATA FOR SUSPENDED ITEM ANALYSIS OF FOUR-POINT BEND TEST DATA

3 = CONTROL INDEX FOR VOLUME FRACTURE CRITERION (ID2V)
 1 : NORMAL STRESS FRACTURE CRITERION (SHEAR-INSENSITIVE CRACK)
 2 : MAXIMUM TENSILE STRESS CRITERION
 3 : COPLANAR STRAIN ENERGY RELEASE RATE CRITERION
 4 : WEIBULL PIA MODEL
 5 : SHETTY'S SEMI-EMPIRICAL CRITERION

1 = CONTROL INDEX FOR SHAPE OF VOLUME CRACKS (ID3V)
 1 : GRIFFITH CRACK
 2 : PENNY-SHAPED CRACK

1 = CONTROL INDEX FOR METHOD OF CALCULATING BATDORF CRACK DENSITY COEFFICIENT (K SUB B) FROM TEST DATA (IKBAT)
 0 : SHEAR-INSENSITIVE METHOD (MODE I FRACTURE ASSUMED)
 1 : SHEAR-SENSITIVE METHOD (FRACTURE ASSUMED TO OCCUR ACCORDING TO THE FRACTURE CRITERION AND CRACK SHAPE SELECTED BY THE ID2 AND ID3 INDICES)

0.2500 = POISSON'S RATIO (PR)

```

*****
*
* STATISTICAL ANALYSIS OF FRACTURE SPECIMEN DATA *
*
*****

```

ECHO OF SPECIMEN INPUT DATA, IN ASCENDING ORDER OF FRACTURE STRESS

0.4000E-01 = OUTER LOAD SPAN OF FOUR-POINT BEND BAR 0.2000E-01 = INNER LOAD SPAN
0.3500E-02 = DEPTH OF SPECIMEN 0.4500E-02 = WIDTH OF SPECIMEN

79 = NUMBER OF SPECIMENS IN BATCH 70.000 = TEMPERATURE OF BATCH

"S"URFACE OR "V"OLUME OR "U"NKOWN FLAW ORIGIN AND RESPECTIVE FAILURE STRESS

VVV	0.4159E+03	0.4584E+03	0.5199E+03
VVV	0.5272E+03	0.5458E+03	0.5606E+03
VVV	0.5725E+03	0.5950E+03	0.6035E+03
SSS	0.6045E+03	0.6093E+03	0.6115E+03
SSS	0.6144E+03	0.6210E+03	0.6215E+03
SSS	0.6216E+03	0.6221E+03	0.6224E+03
SSS	0.6251E+03	0.6258E+03	0.6311E+03
SSS	0.6402E+03	0.6426E+03	0.6490E+03
SSS	0.6501E+03	0.6516E+03	0.6551E+03
SSS	0.6569E+03	0.6570E+03	0.6597E+03
SSS	0.6597E+03	0.6617E+03	0.6620E+03
SSS	0.6621E+03	0.6636E+03	0.6641E+03
SSS	0.6645E+03	0.6664E+03	0.6688E+03
SSS	0.6707E+03	0.6712E+03	0.6717E+03
SSS	0.6721E+03	0.6741E+03	0.6768E+03
SSS	0.6771E+03	0.6783E+03	0.6798E+03
SSS	0.6831E+03	0.6837E+03	0.6855E+03
SSS	0.6867E+03	0.6870E+03	0.6911E+03
SSS	0.6940E+03	0.6950E+03	0.6998E+03
SSS	0.7029E+03	0.7029E+03	0.7029E+03
SSS	0.7030E+03	0.7045E+03	0.7045E+03
SSS	0.7060E+03	0.7100E+03	0.7126E+03
SSS	0.7156E+03	0.7156E+03	0.7158E+03
SSS	0.7164E+03	0.7165E+03	0.7173E+03
SSS	0.7252E+03	0.7254E+03	0.7254E+03
SSS	0.7259E+03	0.7270E+03	0.7287E+03
S	0.7323E+03		

--- STEFANSKY OUTLIER TEST OF SPECIMEN FRACTURE STRESSES ---

RESULTS FROM THE STEFANSKY OUTLIER TEST FOR TEMP. = 70.0000

FAILURE STRESS

0.4159E+03	DEVIATES FROM THE MAIN TREND OF THE DATA AT THE	1% SIGNIFICANCE LEVEL
0.4584E+03	DEVIATES FROM THE MAIN TREND OF THE DATA AT THE	1% SIGNIFICANCE LEVEL
0.5199E+03	DEVIATES FROM THE MAIN TREND OF THE DATA AT THE	1% SIGNIFICANCE LEVEL
0.5272E+03	DEVIATES FROM THE MAIN TREND OF THE DATA AT THE	5% SIGNIFICANCE LEVEL
0.5458E+03	DEVIATES FROM THE MAIN TREND OF THE DATA AT THE	10% SIGNIFICANCE LEVEL

DEVIATION FROM THE MAIN TREND OF THE DATA MAY INDICATE BAD VALUES. MULTIPLE DEVIATIONS FROM THE SAME REGION OF THE DISTRIBUTION INDICATE THAT EITHER A CONCURRENT OR A PARTIALLY CONCURRENT FLAW POPULATION HAS BEEN DETECTED (NOTE THAT A CONCURRENT FLAW POPULATION MAY BE PRESENT BUT NOT BE DETECTED BY THE OUTLIER TEST). DEVIATIONS OCCURRING IN THE SAME REGION OF THE DISTRIBUTION WITH ALL THREE SIGNIFICANCE LEVELS (1%, 5% AND 10%) PRESENT INDICATE A CONCURRENT FLAW POPULATION. DEVIATIONS SHOULD BE EXAMINED AND TREATED ACCORDINGLY (I.E. IGNORE, CENSOR, ADJUST OR ELIMINATE STRESS). JUDGEMENT OF ACTION TAKEN CAN BE DETERMINED FROM THE GOODNESS-OF-FIT TESTS. THE OUTLIER TEST IS NO SUBSTITUTE FOR GRAPHICAL EXAMINATION!!!

-- TEMP. DEP. WEIBULL MODULUS AND CHARACTERISTIC STRENGTH WITH 90% CONFIDENCE BOUNDS DETERMINED BY MAXIMUM LIKELIHOOD ANALYSIS --

NOTE: 90% CONFIDENCE BOUNDS ON PARAMETERS DETERMINED FROM COMPETING FAILURE MODES (CENSORED DATA) ARE APPROXIMATE. FOR CENSORED DATA THE UNBIASED VALUE OF THE PARAMETER "M" IS NOT GIVEN. FOR SAMPLE SIZES LESS THAN 5, CONFIDENCE LIMITS ARE NOT GIVEN.

	TEMP.	M BIASED	M UNBIASED	UP M	LOW M	CHAR. STR.	UP C.S.	LOW C.S.	MEAN	STD. DEV.
VOLUME	70.0000	0.4130E+01		0.5666E+01	0.2179E+01	0.1128E+04	0.1342E+04	0.9542E+03	0.1024E+04	0.2791E+03
SURFACE	70.0000	0.2281E+02		0.2619E+02	0.1920E+02	0.6917E+03	0.6981E+03	0.6853E+03	0.6755E+03	0.3684E+02

STATISTICS FROM THE GOODNESS-OF-FIT TESTS FOR TEMP. = 70.0000

KOLMOGOROV-SMIRNOV TEST

ORDER	FRAC. STR.	WEIB. PROB. OF FAIL.	D+ FACTOR	D- FACTOR	SIGNIFICANCE LEVEL
1	0.4159E+03	0.0161	-0.0035	0.0161	99.0000
2	0.4584E+03	0.0240	0.0013	0.0114	99.0000
3	0.5199E+03	0.0414	-0.0034	0.0161	99.0000
4	0.5272E+03	0.0443	0.0064	0.0063	99.0000
5	0.5458E+03	0.0529	0.0104	0.0023	99.0000
6	0.5606E+03	0.0620	0.0140	-0.0013	99.0000
7	0.5725E+03	0.0714	0.0172	-0.0045	99.0000
8	0.5950E+03	0.0983	0.0029	0.0097	99.0000
9	0.6035E+03	0.1130	0.0009	0.0118	99.0000
10	0.6045E+03	0.1151	0.0114	0.0012	99.0000
11	0.6093E+03	0.1254	0.0139	-0.0012	99.0000
12	0.6115E+03	0.1305	0.0214	-0.0088	99.0000
13	0.6144E+03	0.1379	0.0267	-0.0140	99.0000
14	0.6210E+03	0.1567	0.0205	-0.0079	99.0000
15	0.6215E+03	0.1581	0.0317	-0.0191	99.0000
16	0.6216E+03	0.1585	0.0440	-0.0313	99.0000
17	0.6221E+03	0.1603	0.0549	-0.0422	97.1339
18	0.6224E+03	0.1610	0.0668	-0.0541	87.2422
19	0.6251E+03	0.1704	0.0701	-0.0575	83.1735
20	0.6258E+03	0.1726	0.0805	-0.0679	68.5012
21	0.6311E+03	0.1930	0.0728	-0.0602	79.6191
22	0.6402E+03	0.2346	0.0439	-0.0312	99.0000
23	0.6426E+03	0.2476	0.0435	-0.0309	99.0000
24	0.6490E+03	0.2853	0.0185	-0.0058	99.0000
25	0.6501E+03	0.2924	0.0241	-0.0114	99.0000
26	0.6516E+03	0.3020	0.0271	-0.0145	99.0000
27	0.6551E+03	0.3262	0.0156	-0.0030	99.0000
28	0.6569E+03	0.3399	0.0146	-0.0019	99.0000
29	0.6570E+03	0.3407	0.0264	-0.0137	99.0000
30	0.6597E+03	0.3616	0.0181	-0.0055	99.0000
31	0.6597E+03	0.3616	0.0308	-0.0181	99.0000
32	0.6617E+03	0.3773	0.0277	-0.0151	99.0000
33	0.6620E+03	0.3804	0.0374	-0.0247	99.0000
34	0.6621E+03	0.3811	0.0493	-0.0366	99.0000
35	0.6636E+03	0.3935	0.0496	-0.0369	99.0000
36	0.6641E+03	0.3980	0.0577	-0.0450	95.5201
37	0.6645E+03	0.4015	0.0669	-0.0542	87.1359
38	0.6664E+03	0.4182	0.0628	-0.0502	91.3909
39	0.6688E+03	0.4398	0.0538	-0.0412	97.5998
40	0.6707E+03	0.4580	0.0484	-0.0357	99.0000
41	0.6712E+03	0.4619	0.0571	-0.0445	95.8855
42	0.6717E+03	0.4674	0.0643	-0.0516	89.9720
43	0.6721E+03	0.4709	0.0734	-0.0607	78.8750
44	0.6741E+03	0.4909	0.0661	-0.0534	88.0606
45	0.6768E+03	0.5182	0.0515	-0.0388	98.4919
46	0.6771E+03	0.5207	0.0616	-0.0489	92.5627
47	0.6783E+03	0.5338	0.0611	-0.0484	92.9632
48	0.6798E+03	0.5495	0.0581	-0.0454	95.2717
49	0.6831E+03	0.5842	0.0360	-0.0234	99.0000
50	0.6837E+03	0.5909	0.0420	-0.0293	99.0000
51	0.6855E+03	0.6100	0.0356	-0.0229	99.0000
52	0.6867E+03	0.6237	0.0345	-0.0219	99.0000
53	0.6870E+03	0.6264	0.0445	-0.0318	99.0000
54	0.6911E+03	0.6712	0.0124	0.0003	99.0000
55	0.6940E+03	0.7027	-0.0065	0.0192	99.0000
56	0.6950E+03	0.7135	-0.0046	0.0173	99.0000
57	0.6998E+03	0.7635	-0.0419	0.0546	97.2613
58	0.7029E+03	0.7946	-0.0604	0.0731	79.2561
59	0.7029E+03	0.7946	-0.0478	0.0604	93.5064
60	0.7029E+03	0.7950	-0.0355	0.0482	99.0000
61	0.7030E+03	0.7955	-0.0233	0.0360	99.0000
62	0.7045E+03	0.8099	-0.0251	0.0378	99.0000
63	0.7045E+03	0.8105	-0.0130	0.0257	99.0000
64	0.7060E+03	0.8247	-0.0146	0.0272	99.0000
65	0.7100E+03	0.8598	-0.0370	0.0496	98.9973
66	0.7126E+03	0.8801	-0.0447	0.0574	95.7363
67	0.7156E+03	0.9022	-0.0541	0.0667	87.3420
68	0.7156E+03	0.9022	-0.0414	0.0541	97.5075
69	0.7158E+03	0.9031	-0.0297	0.0424	99.0000
70	0.7164E+03	0.9076	-0.0215	0.0341	99.0000
71	0.7165E+03	0.9081	-0.0094	0.0220	99.0000

ORDER	FRAC. STR.	WEIB. PROB. OF FAIL.	D+ FACTOR	D- FACTOR	SIGNIFICANCE LEVEL
72	0.7173E+03	0.9134	-0.0020	0.0146	99.0000
73	0.7252E+03	0.9549	-0.0309	0.0435	99.0000
74	0.7254E+03	0.9560	-0.0193	0.0320	99.0000
75	0.7254E+03	0.9560	-0.0067	0.0193	99.0000
76	0.7259E+03	0.9581	0.0039	0.0087	99.0000
77	0.7270E+03	0.9624	0.0123	0.0003	99.0000
78	0.7287E+03	0.9680	0.0193	-0.0067	99.0000
79	0.7323E+03	0.9786	0.0214	-0.0088	99.0000

KOLMOGOROV-SMIRNOV TEST YIELDS STATISTIC $D = \max(D+, D-) = 0.0805$ WITH AN ASSOCIATED SIGNIFICANCE LEVEL OF 68.5%

ANDERSON-DARLING TEST YIELDS STATISTIC $A^{*2} = 0.6725$ WITH AN ASSOCIATED SIGNIFICANCE LEVEL OF 58.3%

KANOFKY-SRINIVASAN 90% CONFIDENCE BANDS ABOUT THE WEIBULL DISTRIBUTION FOR TEMP. = 70.0000

THE KANOFKY-SRINIVASAN FACTOR FOR THIS DISTRIBUTION IS 0.0836 FOR A SAMPLE SIZE OF 79

ORDER FRAC. STR. WEIB. PROB. OF FAIL. UPPER CONFIDENCE BAND MEDIAN RANK LOWER CONFIDENCE BAND

ORDER	FRAC. STR.	WEIB. PROB. OF FAIL.	UPPER CONFIDENCE BAND	MEDIAN RANK	LOWER CONFIDENCE BAND
1	0.4159E+03	0.0161	0.0997	0.0088	0.0000
2	0.4584E+03	0.0240	0.1077	0.0214	0.0000
3	0.5199E+03	0.0414	0.1250	0.0340	0.0000
4	0.5272E+03	0.0443	0.1279	0.0466	0.0000
5	0.5458E+03	0.0529	0.1365	0.0592	0.0000
6	0.5606E+03	0.0620	0.1456	0.0718	0.0000
7	0.5725E+03	0.0714	0.1551	0.0844	0.0000
8	0.5950E+03	0.0983	0.1820	0.0970	0.0147
9	0.6035E+03	0.1130	0.1967	0.1096	0.0294
10	0.6045E+03	0.1151	0.1988	0.1222	0.0315
11	0.6093E+03	0.1254	0.2090	0.1348	0.0418
12	0.6115E+03	0.1305	0.2141	0.1474	0.0469
13	0.6144E+03	0.1379	0.2215	0.1599	0.0542
14	0.6210E+03	0.1567	0.2403	0.1725	0.0731
15	0.6215E+03	0.1581	0.2418	0.1851	0.0745
16	0.6216E+03	0.1585	0.2422	0.1977	0.0749
17	0.6221E+03	0.1603	0.2440	0.2103	0.0767
18	0.6224E+03	0.1610	0.2447	0.2229	0.0774
19	0.6251E+03	0.1704	0.2540	0.2355	0.0867
20	0.6258E+03	0.1726	0.2563	0.2481	0.0890
21	0.6311E+03	0.1930	0.2766	0.2607	0.1094
22	0.6402E+03	0.2346	0.3182	0.2733	0.1510
23	0.6426E+03	0.2476	0.3313	0.2859	0.1640
24	0.6490E+03	0.2853	0.3690	0.2985	0.2017
25	0.6501E+03	0.2924	0.3760	0.3111	0.2088
26	0.6516E+03	0.3020	0.3856	0.3237	0.2183
27	0.6551E+03	0.3262	0.4098	0.3363	0.2425
28	0.6569E+03	0.3399	0.4235	0.3489	0.2562
29	0.6570E+03	0.3407	0.4243	0.3615	0.2571
30	0.6597E+03	0.3616	0.4453	0.3741	0.2780
31	0.6597E+03	0.3616	0.4453	0.3866	0.2780
32	0.6617E+03	0.3773	0.4609	0.3992	0.2937
33	0.6620E+03	0.3804	0.4640	0.4118	0.2967
34	0.6621E+03	0.3811	0.4647	0.4244	0.2975
35	0.6636E+03	0.3935	0.4771	0.4370	0.3098
36	0.6641E+03	0.3980	0.4816	0.4496	0.3144
37	0.6645E+03	0.4015	0.4851	0.4622	0.3178
38	0.6664E+03	0.4182	0.5018	0.4748	0.3345
39	0.6688E+03	0.4398	0.5234	0.4874	0.3562
40	0.6707E+03	0.4580	0.5416	0.5000	0.3743
41	0.6712E+03	0.4619	0.5455	0.5126	0.3782
42	0.6717E+03	0.4674	0.5510	0.5252	0.3837
43	0.6721E+03	0.4709	0.5546	0.5378	0.3873
44	0.6741E+03	0.4909	0.5745	0.5504	0.4073
45	0.6768E+03	0.5182	0.6018	0.5630	0.4345
46	0.6771E+03	0.5207	0.6043	0.5756	0.4371

ORDER	FRAC. STR.	WEIB. PROB.	OF FAIL.	UPPER CONFIDENCE BAND	MEDIAN RANK	LOWER CONFIDENCE BAND
47	0.6783E+03	0.5338		0.6175	0.5882	0.4502
48	0.6798E+03	0.5495		0.6332	0.6008	0.4659
49	0.6831E+03	0.5842		0.6679	0.6134	0.5006
50	0.6837E+03	0.5909		0.6745	0.6259	0.5073
51	0.6855E+03	0.6100		0.6936	0.6385	0.5263
52	0.6867E+03	0.6237		0.7073	0.6511	0.5401
53	0.6870E+03	0.6264		0.7100	0.6637	0.5428
54	0.6911E+03	0.6712		0.7548	0.6763	0.5875
55	0.6940E+03	0.7027		0.7864	0.6889	0.6191
56	0.6950E+03	0.7135		0.7971	0.7015	0.6298
57	0.6998E+03	0.7635		0.8471	0.7141	0.6798
58	0.7029E+03	0.7946		0.8782	0.7267	0.7110
59	0.7029E+03	0.7946		0.8782	0.7393	0.7110
60	0.7029E+03	0.7950		0.8786	0.7519	0.7114
61	0.7030E+03	0.7955		0.8791	0.7645	0.7119
62	0.7045E+03	0.8099		0.8936	0.7771	0.7263
63	0.7045E+03	0.8105		0.8941	0.7897	0.7269
64	0.7060E+03	0.8247		0.9083	0.8023	0.7411
65	0.7100E+03	0.8598		0.9434	0.8149	0.7761
66	0.7126E+03	0.8801		0.9638	0.8275	0.7965
67	0.7156E+03	0.9022		0.9858	0.8401	0.8185
68	0.7156E+03	0.9022		0.9858	0.8526	0.8185
69	0.7158E+03	0.9031		0.9867	0.8652	0.8195
70	0.7164E+03	0.9076		0.9912	0.8773	0.8239
71	0.7165E+03	0.9081		0.9917	0.8904	0.8245
72	0.7173E+03	0.9134		0.9970	0.9030	0.8297
73	0.7252E+03	0.9549		1.0000	0.9156	0.8713
74	0.7254E+03	0.9560		1.0000	0.9282	0.8724
75	0.7254E+03	0.9560		1.0000	0.9408	0.8724
76	0.7259E+03	0.9581		1.0000	0.9534	0.8745
77	0.7270E+03	0.9624		1.0000	0.9660	0.8787
78	0.7287E+03	0.9680		1.0000	0.9786	0.8844
79	0.7323E+03	0.9786		1.0000	0.9912	0.8950

```

*****
*
*           VOLUME FLAW PARAMETER ANALYSIS           *
*
*****

```

*** BATDORF MODEL --- CRACK ORIENTATION, CRACK SHAPE, AND FRACTURE CRITERION ARE CONSIDERED ***

--- TEMPERATURE DEPENDENT MATERIAL PARAMETERS FOR MATERIAL NUMBER 1

WEIBULL MODULUS (SHAPE PARAMETER), M (DIMENSIONLESS)
 NORMALIZED BATDORF CRACK DENSITY COEFFICIENT, K (DIMENSIONLESS)
 SCALE PARAMETER, SP (UNITS OF STRESS*VOLUME**(1/M))

TEMPERATURE	M BIASED	K	SP
70.0000	0.4130E+01	0.5130E+01	0.1787E+02

FRACTURE CRITERION = COPLANAR STRAIN ENERGY RELEASE RATE CRITERION
 CRACK SHAPE = GRIFFITH CRACK

```

*****
*
*           ECHO OF MATERIAL CONTROL INPUT           *
*
*****

```

TITLE = SI3N4 SPECIMEN DATA FROM ASEA CERAMA FOR SURFACE FLAW ANALYSIS

2 = MATERIAL IDENTIFICATION NUMBER (MATID)

2 = CONTROL INDEX FOR VOLUME OR SURFACE FLAW ANALYSIS (ID4)
 1 : VOLUME
 2 : SURFACE

0 = CONTROL INDEX FOR METHOD OF CALCULATING WEIBULL PARAMETERS
 FROM THE EXPERIMENTAL FRACTURE DATA (MLORLE)
 0 : MAXIMUM LIKELIHOOD
 1 : LEAST-SQUARES LINEAR REGRESSION

5 = CONTROL INDEX FOR EXPERIMENTAL DATA (ID1)
 1 : UNIFORM UNIAXIAL TENSILE SPECIMEN TEST DATA
 2 : FOUR-POINT BEND TEST DATA
 3 : DIRECT INPUT OF THE WEIBULL PARAMETERS, M AND SP
 (SHAPE PARAMETER AND SCALE PARAMETER)
 4 : CENSORED DATA FOR SUSPENDED ITEM ANALYSIS OF
 UNIFORM UNIAXIAL TENSILE SPECIMEN TEST DATA
 5 : CENSORED DATA FOR SUSPENDED ITEM ANALYSIS OF
 FOUR-POINT BEND TEST DATA

3 = CONTROL INDEX FOR SURFACE FRACTURE CRITERION (ID2S)
 1 : NORMAL STRESS FRACTURE CRITERION
 (SHEAR-INSENSITIVE CRACK)
 3 : COPLANAR STRAIN ENERGY RELEASE RATE CRITERION
 4 : WEIBULL PIA MODEL
 5 : SHETTY'S SEMI-EMPIRICAL CRITERION

1 = CONTROL INDEX FOR SHAPE OF SURFACE CRACKS (ID3S)
 1 : GRIFFITH CRACK
 (ASSOCIATED WITH STRAIN ENERGY RELEASE RATE CRITERION)
 (ASSOCIATED WITH SHETTY'S SEMI-EMPIRICAL CRITERION)
 3 : GRIFFITH NOTCH
 (ASSOCIATED WITH STRAIN ENERGY RELEASE RATE CRITERION)
 (ASSOCIATED WITH SHETTY'S SEMI-EMPIRICAL CRITERION)
 4 : SEMICIRCULAR CRACK
 (ASSOCIATED WITH SHETTY'S SEMI-EMPIRICAL CRITERION)

1 = CONTROL INDEX FOR METHOD OF CALCULATING BATDORF CRACK DENSITY COEFFICIENT
 (K SUB B) FROM TEST DATA (IKBAT)
 0 : SHEAR-INSENSITIVE METHOD (MODE I FRACTURE ASSUMED)
 1 : SHEAR-SENSITIVE METHOD (FRACTURE ASSUMED TO OCCUR
 ACCORDING TO THE FRACTURE CRITERION AND CRACK
 SHAPE SELECTED BY THE ID2 AND ID3 INDICES)

0.2500 = POISSON'S RATIO (PR)

```

XXXXXXXXXXXXXXXXXXXXXXXXXXXXXXXXXXXXXXXXXXXXXXXXXXXXXXXXXXXXXXXXXXXX
*
*   STATISTICAL ANALYSIS OF FRACTURE SPECIMEN DATA   *
*
XXXXXXXXXXXXXXXXXXXXXXXXXXXXXXXXXXXXXXXXXXXXXXXXXXXXXXXXXXXXXXXXXXXX

```

ECHO OF SPECIMEN INPUT DATA, IN ASCENDING ORDER OF FRACTURE STRESS

0.4000E-01 = OUTER LOAD SPAN OF FOUR-POINT BEND BAR 0.2000E-01 = INNER LOAD SPAN
0.3500E-02 = DEPTH OF SPECIMEN 0.4500E-02 = WIDTH OF SPECIMEN

79 = NUMBER OF SPECIMENS IN BATCH 70.000 = TEMPERATURE OF BATCH

"S"URFACE OR "V"OLUME OR "U"NKOWN FLAW ORIGIN AND RESPECTIVE FAILURE STRESS

VVV	0.4159E+03	0.4584E+03	0.5199E+03
VVV	0.5272E+03	0.5458E+03	0.5606E+03
VVV	0.5725E+03	0.5950E+03	0.6035E+03
SSS	0.6045E+03	0.6093E+03	0.6115E+03
SSS	0.6144E+03	0.6210E+03	0.6215E+03
SSS	0.6216E+03	0.6221E+03	0.6224E+03
SSS	0.6251E+03	0.6258E+03	0.6311E+03
SSS	0.6402E+03	0.6426E+03	0.6490E+03
SSS	0.6501E+03	0.6516E+03	0.6551E+03
SSS	0.6569E+03	0.6570E+03	0.6597E+03
SSS	0.6597E+03	0.6617E+03	0.6620E+03
SSS	0.6621E+03	0.6636E+03	0.6641E+03
SSS	0.6645E+03	0.6664E+03	0.6688E+03
SSS	0.6707E+03	0.6712E+03	0.6717E+03
SSS	0.6721E+03	0.6741E+03	0.6768E+03
SSS	0.6771E+03	0.6783E+03	0.6798E+03
SSS	0.6831E+03	0.6837E+03	0.6855E+03
SSS	0.6867E+03	0.6870E+03	0.6911E+03
SSS	0.6940E+03	0.6950E+03	0.6998E+03
SSS	0.7029E+03	0.7029E+03	0.7029E+03
SSS	0.7030E+03	0.7045E+03	0.7045E+03
SSS	0.7060E+03	0.7100E+03	0.7126E+03
SSS	0.7156E+03	0.7156E+03	0.7158E+03
SSS	0.7164E+03	0.7165E+03	0.7173E+03
SSS	0.7252E+03	0.7254E+03	0.7254E+03
SSS	0.7259E+03	0.7270E+03	0.7287E+03
S	0.7323E+03		

--- STEFANSKY OUTLIER TEST OF SPECIMEN FRACTURE STRESSES ---

RESULTS FROM THE STEFANSKY OUTLIER TEST FOR TEMP. = 70.0000

FAILURE STRESS

0.4159E+03	DEVIATES FROM THE MAIN TREND OF THE DATA AT THE	1%	SIGNIFICANCE LEVEL
0.4584E+03	DEVIATES FROM THE MAIN TREND OF THE DATA AT THE	1%	SIGNIFICANCE LEVEL
0.5199E+03	DEVIATES FROM THE MAIN TREND OF THE DATA AT THE	1%	SIGNIFICANCE LEVEL
0.5272E+03	DEVIATES FROM THE MAIN TREND OF THE DATA AT THE	5%	SIGNIFICANCE LEVEL
0.5458E+03	DEVIATES FROM THE MAIN TREND OF THE DATA AT THE	10%	SIGNIFICANCE LEVEL

DEVIATION FROM THE MAIN TREND OF THE DATA MAY INDICATE BAD VALUES. MULTIPLE DEVIATIONS FROM THE SAME REGION OF THE DISTRIBUTION INDICATE THAT EITHER A CONCURRENT OR A PARTIALLY CONCURRENT FLAW POPULATION HAS BEEN DETECTED (NOTE THAT A CONCURRENT FLAW POPULATION MAY BE PRESENT BUT NOT BE DETECTED BY THE OUTLIER TEST). DEVIATIONS OCCURRING IN THE SAME REGION OF THE DISTRIBUTION WITH ALL THREE SIGNIFICANCE LEVELS (1%, 5% AND 10%) PRESENT INDICATE A CONCURRENT FLAW POPULATION. DEVIATIONS SHOULD BE EXAMINED AND TREATED ACCORDINGLY (I.E. IGNORE, CENSOR, ADJUST OR ELIMINATE STRESS). JUDGEMENT OF ACTION TAKEN CAN BE DETERMINED FROM THE GOODNESS-OF-FIT TESTS. THE OUTLIER TEST IS NO SUBSTITUTE FOR GRAPHICAL EXAMINATION!!!

-- TEMP. DEP. WEIBULL MODULUS AND CHARACTERISTIC STRENGTH WITH 90% CONFIDENCE BOUNDS DETERMINED BY MAXIMUM LIKELIHOOD ANALYSIS --

NOTE: 90% CONFIDENCE BOUNDS ON PARAMETERS DETERMINED FROM COMPETING FAILURE MODES (CENSORED DATA) ARE APPROXIMATE. FOR CENSORED DATA THE UNBIASED VALUE OF THE PARAMETER "M" IS NOT GIVEN. FOR SAMPLE SIZES LESS THAN 5, CONFIDENCE LIMITS ARE NOT GIVEN.

	TEMP.	M BIASED	M UNBIASED	UP M	LOW M	CHAR. STR.	UP C.S.	LOW C.S.	MEAN	STD. DEV.
VOLUME	70.0000	0.4130E+01		0.5666E+01	0.2179E+01	0.1128E+04	0.1342E+04	0.9542E+03	0.1024E+04	0.2791E+03
SURFACE	70.0000	0.2281E+02		0.2619E+02	0.1920E+02	0.6917E+03	0.6981E+03	0.6853E+03	0.6755E+03	0.3684E+02

STATISTICS FROM THE GOODNESS-OF-FIT TESTS FOR TEMP. = 70.0000

KOLMOGOROV-SMIRNOV TEST

ORDER	FRAC. STR.	WEIB. PROB. OF FAIL.	D+ FACTOR	D- FACTOR	SIGNIFICANCE LEVEL
1	0.4159E+03	0.0161	-0.0035	0.0161	99.0000
2	0.4584E+03	0.0240	0.0013	0.0114	99.0000
3	0.5199E+03	0.0414	-0.0034	0.0161	99.0000
4	0.5272E+03	0.0443	0.0064	0.0063	99.0000
5	0.5458E+03	0.0529	0.0104	0.0023	99.0000
6	0.5606E+03	0.0620	0.0140	-0.0013	99.0000
7	0.5725E+03	0.0714	0.0172	-0.0045	99.0000
8	0.5950E+03	0.0983	0.0029	0.0097	99.0000
9	0.6035E+03	0.1130	0.0009	0.0118	99.0000
10	0.6045E+03	0.1151	0.0114	0.0012	99.0000
11	0.6093E+03	0.1254	0.0139	-0.0012	99.0000
12	0.6115E+03	0.1305	0.0214	-0.0088	99.0000
13	0.6144E+03	0.1379	0.0267	-0.0140	99.0000
14	0.6210E+03	0.1567	0.0205	-0.0079	99.0000
15	0.6215E+03	0.1581	0.0317	-0.0191	99.0000
16	0.6216E+03	0.1585	0.0440	-0.0313	99.0000
17	0.6221E+03	0.1603	0.0549	-0.0422	97.1339
18	0.6224E+03	0.1610	0.0668	-0.0541	87.2422
19	0.6251E+03	0.1704	0.0701	-0.0575	83.1735
20	0.6258E+03	0.1726	0.0805	-0.0679	68.5012
21	0.6311E+03	0.1930	0.0728	-0.0602	79.6191
22	0.6402E+03	0.2346	0.0439	-0.0312	99.0000
23	0.6426E+03	0.2476	0.0435	-0.0309	99.0000
24	0.6490E+03	0.2853	0.0185	-0.0058	99.0000
25	0.6501E+03	0.2924	0.0241	-0.0114	99.0000
26	0.6516E+03	0.3020	0.0271	-0.0145	99.0000
27	0.6551E+03	0.3262	0.0156	-0.0030	99.0000
28	0.6569E+03	0.3399	0.0146	-0.0019	99.0000
29	0.6570E+03	0.3407	0.0264	-0.0137	99.0000
30	0.6597E+03	0.3616	0.0181	-0.0055	99.0000
31	0.6597E+03	0.3616	0.0308	-0.0181	99.0000
32	0.6617E+03	0.3773	0.0277	-0.0151	99.0000
33	0.6620E+03	0.3804	0.0374	-0.0247	99.0000
34	0.6621E+03	0.3811	0.0493	-0.0366	99.0000
35	0.6636E+03	0.3935	0.0496	-0.0369	99.0000
36	0.6641E+03	0.3980	0.0577	-0.0450	95.5201
37	0.6645E+03	0.4015	0.0669	-0.0542	87.1359
38	0.6664E+03	0.4182	0.0628	-0.0502	91.3909
39	0.6688E+03	0.4398	0.0538	-0.0412	97.5998
40	0.6707E+03	0.4580	0.0484	-0.0357	99.0000
41	0.6712E+03	0.4619	0.0571	-0.0445	95.8855
42	0.6717E+03	0.4674	0.0643	-0.0516	89.9720
43	0.6721E+03	0.4709	0.0734	-0.0607	78.8750
44	0.6741E+03	0.4909	0.0661	-0.0534	88.0606
45	0.6768E+03	0.5182	0.0515	-0.0388	98.4919
46	0.6771E+03	0.5207	0.0616	-0.0489	92.5627
47	0.6783E+03	0.5338	0.0611	-0.0484	92.9632
48	0.6798E+03	0.5495	0.0581	-0.0454	95.2717
49	0.6831E+03	0.5842	0.0360	-0.0234	99.0000
50	0.6837E+03	0.5909	0.0420	-0.0293	99.0000
51	0.6855E+03	0.6100	0.0356	-0.0229	99.0000
52	0.6867E+03	0.6237	0.0345	-0.0219	99.0000
53	0.6870E+03	0.6264	0.0445	-0.0318	99.0000
54	0.6911E+03	0.6712	0.0124	0.0003	99.0000
55	0.6940E+03	0.7027	-0.0065	0.0192	99.0000
56	0.6950E+03	0.7135	-0.0046	0.0173	99.0000
57	0.6998E+03	0.7635	-0.0419	0.0546	97.2613
58	0.7029E+03	0.7946	-0.0604	0.0731	79.2561
59	0.7029E+03	0.7946	-0.0478	0.0604	93.5064
60	0.7029E+03	0.7950	-0.0355	0.0482	99.0000
61	0.7030E+03	0.7955	-0.0233	0.0360	99.0000
62	0.7045E+03	0.8099	-0.0251	0.0378	99.0000
63	0.7045E+03	0.8105	-0.0130	0.0257	99.0000
64	0.7060E+03	0.8247	-0.0146	0.0272	99.0000
65	0.7100E+03	0.8598	-0.0370	0.0496	98.9973

ORDER	FRAC. STR.	WEIB. PROB. OF FAIL.	D+ FACTOR	D- FACTOR	SIGNIFICANCE LEVEL
66	0.7126E+03	0.8801	-0.0447	0.0574	95.7363
67	0.7156E+03	0.9022	-0.0541	0.0667	87.3420
68	0.7156E+03	0.9022	-0.0414	0.0541	97.5075
69	0.7158E+03	0.9031	-0.0297	0.0424	99.0000
70	0.7164E+03	0.9076	-0.0215	0.0341	99.0000
71	0.7165E+03	0.9081	-0.0094	0.0220	99.0000
72	0.7173E+03	0.9134	-0.0020	0.0146	99.0000
73	0.7252E+03	0.9549	-0.0309	0.0435	99.0000
74	0.7254E+03	0.9560	-0.0193	0.0320	99.0000
75	0.7254E+03	0.9560	-0.0067	0.0193	99.0000
76	0.7259E+03	0.9581	0.0039	0.0087	99.0000
77	0.7270E+03	0.9624	0.0123	0.0003	99.0000
78	0.7287E+03	0.9680	0.0193	-0.0067	99.0000
79	0.7323E+03	0.9786	0.0214	-0.0088	99.0000

KOLMOGOROV-SMIRNOV TEST YIELDS STATISTIC D = MAX(D+,D-) = 0.0805 WITH AN ASSOCIATED SIGNIFICANCE LEVEL OF 68.5%

ANDERSON-DARLING TEST YIELDS STATISTIC A**2 = 0.6725 WITH AN ASSOCIATED SIGNIFICANCE LEVEL OF 58.3%

KANOFSKY-SRINIVASAN 90% CONFIDENCE BANDS ABOUT THE WEIBULL DISTRIBUTION FOR TEMP. = 70.0000

THE KANOFSKY-SRINIVASAN FACTOR FOR THIS DISTRIBUTION IS 0.0836 FOR A SAMPLE SIZE OF 79

ORDER	FRAC. STR.	WEIB. PROB. OF FAIL.	UPPER CONFIDENCE BAND	MEDIAN RANK	LOWER CONFIDENCE BAND
1	0.4159E+03	0.0161	0.0997	0.0088	0.0000
2	0.4584E+03	0.0240	0.1077	0.0214	0.0000
3	0.5199E+03	0.0414	0.1250	0.0340	0.0000
4	0.5272E+03	0.0443	0.1279	0.0466	0.0000
5	0.5458E+03	0.0529	0.1365	0.0592	0.0000
6	0.5606E+03	0.0620	0.1456	0.0718	0.0000
7	0.5725E+03	0.0714	0.1551	0.0844	0.0000
8	0.5950E+03	0.0983	0.1820	0.0970	0.0147
9	0.6035E+03	0.1130	0.1967	0.1096	0.0294
10	0.6045E+03	0.1151	0.1988	0.1222	0.0315
11	0.6093E+03	0.1254	0.2090	0.1348	0.0418
12	0.6115E+03	0.1305	0.2141	0.1474	0.0469
13	0.6144E+03	0.1379	0.2215	0.1599	0.0542
14	0.6210E+03	0.1567	0.2403	0.1725	0.0731
15	0.6215E+03	0.1581	0.2418	0.1851	0.0745
16	0.6216E+03	0.1585	0.2422	0.1977	0.0749
17	0.6221E+03	0.1603	0.2440	0.2103	0.0767
18	0.6224E+03	0.1610	0.2447	0.2229	0.0774
19	0.6251E+03	0.1704	0.2540	0.2355	0.0867
20	0.6258E+03	0.1726	0.2563	0.2481	0.0890
21	0.6311E+03	0.1930	0.2766	0.2607	0.1094
22	0.6402E+03	0.2346	0.3182	0.2733	0.1510
23	0.6426E+03	0.2476	0.3313	0.2859	0.1640
24	0.6490E+03	0.2853	0.3690	0.2985	0.2017
25	0.6501E+03	0.2924	0.3760	0.3111	0.2088
26	0.6516E+03	0.3020	0.3856	0.3237	0.2183
27	0.6551E+03	0.3262	0.4098	0.3363	0.2425
28	0.6569E+03	0.3399	0.4235	0.3489	0.2562
29	0.6570E+03	0.3407	0.4243	0.3615	0.2571
30	0.6597E+03	0.3616	0.4453	0.3741	0.2780
31	0.6597E+03	0.3616	0.4453	0.3866	0.2780
32	0.6617E+03	0.3773	0.4609	0.3992	0.2937
33	0.6620E+03	0.3804	0.4640	0.4118	0.2967
34	0.6621E+03	0.3811	0.4647	0.4244	0.2975
35	0.6636E+03	0.3935	0.4771	0.4370	0.3098
36	0.6641E+03	0.3980	0.4816	0.4496	0.3144
37	0.6645E+03	0.4015	0.4851	0.4622	0.3178
38	0.6664E+03	0.4182	0.5018	0.4748	0.3345
39	0.6688E+03	0.4398	0.5234	0.4874	0.3562
40	0.6707E+03	0.4580	0.5416	0.5000	0.3743
41	0.6712E+03	0.4619	0.5455	0.5126	0.3782
42	0.6717E+03	0.4674	0.5510	0.5252	0.3837
43	0.6721E+03	0.4709	0.5546	0.5378	0.3873
44	0.6741E+03	0.4909	0.5745	0.5504	0.4073

THE KANOFKY-SRINIVASAN FACTOR FOR THIS DISTRIBUTION IS 0.0836 FOR A SAMPLE SIZE OF 79

ORDER	FRAC. STR.	WEIB. PROB. OF FAIL.	UPPER CONFIDENCE BAND	MEDIAN RANK	LOWER CONFIDENCE BAND
45	0.6768E+03	0.5182	0.6018	0.5630	0.4345
46	0.6771E+03	0.5207	0.6043	0.5756	0.4371
47	0.6783E+03	0.5338	0.6175	0.5882	0.4502
48	0.6798E+03	0.5495	0.6332	0.6008	0.4659
49	0.6831E+03	0.5842	0.6679	0.6134	0.5006
50	0.6837E+03	0.5909	0.6745	0.6259	0.5073
51	0.6855E+03	0.6100	0.6936	0.6385	0.5263
52	0.6867E+03	0.6237	0.7073	0.6511	0.5401
53	0.6870E+03	0.6264	0.7100	0.6637	0.5428
54	0.6911E+03	0.6712	0.7548	0.6763	0.5875
55	0.6940E+03	0.7027	0.7864	0.6889	0.6191
56	0.6950E+03	0.7135	0.7971	0.7015	0.6298
57	0.6998E+03	0.7635	0.8471	0.7141	0.6798
58	0.7029E+03	0.7946	0.8782	0.7267	0.7110
59	0.7029E+03	0.7946	0.8782	0.7393	0.7110
60	0.7029E+03	0.7950	0.8786	0.7519	0.7114
61	0.7030E+03	0.7955	0.8791	0.7645	0.7119
62	0.7045E+03	0.8099	0.8936	0.7771	0.7263
63	0.7045E+03	0.8105	0.8941	0.7897	0.7269
64	0.7060E+03	0.8247	0.9083	0.8023	0.7411
65	0.7100E+03	0.8598	0.9434	0.8149	0.7761
66	0.7126E+03	0.8801	0.9638	0.8275	0.7965
67	0.7156E+03	0.9022	0.9858	0.8401	0.8185
68	0.7156E+03	0.9022	0.9858	0.8526	0.8185
69	0.7158E+03	0.9031	0.9867	0.8652	0.8195
70	0.7164E+03	0.9076	0.9912	0.8778	0.8239
71	0.7165E+03	0.9081	0.9917	0.8904	0.8245
72	0.7173E+03	0.9134	0.9970	0.9030	0.8297
73	0.7252E+03	0.9549	1.0000	0.9156	0.8713
74	0.7254E+03	0.9560	1.0000	0.9282	0.8724
75	0.7254E+03	0.9560	1.0000	0.9408	0.8724
76	0.7259E+03	0.9581	1.0000	0.9534	0.8745
77	0.7270E+03	0.9624	1.0000	0.9660	0.8787
78	0.7287E+03	0.9680	1.0000	0.9786	0.8844
79	0.7323E+03	0.9786	1.0000	0.9912	0.8950

```

*****
*
*          SURFACE FLAW PARAMETER ANALYSIS          *
*
*****

```

**** BATDORF MODEL --- CRACK ORIENTATION, CRACK SHAPE, AND FRACTURE CRITERION ARE CONSIDERED ****

--- TEMPERATURE DEPENDENT MATERIAL PARAMETERS FOR MATERIAL NUMBER 2

WEIBULL MODULUS (SHAPE PARAMETER), M (DIMENSIONLESS)
 NORMALIZED BATDORF CRACK DENSITY COEFFICIENT, K (DIMENSIONLESS)
 SCALE PARAMETER, SP (UNITS OF STRESS*AREA*(1/M))

TEMPERATURE	M BIASED	K	SP
70.0000	0.2281E+02	0.6050E+01	0.4613E+03

FRACTURE CRITERION = COPLANAR STRAIN ENERGY RELEASE RATE CRITERION
 CRACK SHAPE = GRIFFITH CRACK

Example 4—Thermomechanically Loaded Annular Disk

To demonstrate the various features of the CARES finite element postprocessor program, we prepared a modified version of **Example 2—Rotating Annular Disk**. The mesh geometry used was identical to example 2 (fig. 18). However, some elements were assigned different material properties, and a radial variation in temperature was imposed.

The solution method used was Rigid Format 47, which is cyclic symmetry statics. As in example 2 the model consisted of eight HEXA elements encompassing a 15° sector with only one element spanning the disk thickness and circumference. The disk inside diameter was 12.7 mm (0.5 in.), the outside diameter was 82.55 mm (3.25 in.), and the thickness was 3.8 mm (0.15 in.). QUAD8 shell elements were attached to the outside faces of the HEXA elements to define the external surfaces of the component. QUAD8 and HEXA elements shared common nodes. Note that a HEXA element has six faces and that in the most general case a QUAD8 element could be attached to each face. For this example, the maximum number of QUAD8 elements attached to a given HEXA element was three, corresponding to the solid elements located at the inner and outer disk radii. The shell elements had a small thickness of 2.54×10^{-5} mm (1.0×10^{-6} in.), and only membrane properties were used such that the overall stiffness of the shell elements was negligible relative to the solid elements. A listing of the MSC/NASTRAN input file is provided at the end of this example.

For example 2 the disk was entirely made of silicon nitride, and it was rotated with increasing velocities until fracture occurred at room temperature. For this example the disk consisted of three materials, two were ceramics and one was metal. The material properties were assigned via PSHELL, PSOLID, and MAT1 cards in the NASTRAN BULK DATA. The MAT1 card assumes temperature-independent material properties. Its use here is only for convenience and does not imply that it must be employed. Only the PSHELL and PSOLID cards are required for postprocessing with CARES. For this example the innermost solid element, element 1, was a ceramic material with an assigned MAT1 material ID of 302. The three shell elements (100, 110, and 130) that shared common nodes with this element were also assigned to material ID 302. The outermost HEXA element, 8, was assigned to MAT1 material ID 301 and had material properties consistent with steel. The three shell elements (107, 117, and 120) that shared nodes with HEXA element 8 also had material ID 301. The remaining 6 solid and 12 shell elements were assigned to MAT1 material ID 300 and were assumed to be silicon nitride, as in example 2. The properties for material 302 are arbitrary but are consistent with a typical ceramic.

For this example a thermal gradient that varied with radius was imposed on the nodes. The temperature varied from 1093 °C (2000 °F) at the inner bore to 704 °C (1300 °F) at the outside periphery. The gradient was approximately linear, and the loads were arbitrarily imposed. The loads were assigned via TEMP and LOADCYN BULK DATA cards. A small rotation of 3000 rpm was also applied via the RFORCE and LOADCYH BULK DATA cards consistent with **Example Problem 2—Rotating Annular Disk**. For a complete discussion of how to prepare an MSC/NASTRAN model for subsequent postprocessing with CARES, the user should consult the **Input Information** section of this manual.

The CARES input TEMPLET INP file is listed at the end of this example along with the corresponding CARES2 output file. Note that NMATS and NMATV both equal 2 in the Master Control Input. NMATS and NMATV both refer to materials 300 and 302 in the Material Control Input (MATID). Material 301 is steel and is subsequently ignored in the reliability analysis by not specifying it in either the Master Control Input or the Material Control Input. However in the CARES2 output, element stresses, volumes, areas, and temperatures are listed for HEXA element 8 and QUAD8 elements 107, 117, and 120—although these elements correspond to material number 301. This is because all HEXA, PENTA, TRIAX6, QUAD8, and TRIA6 elements are read and processed in the ELEM subroutine and the material ID only comes into consideration for the reliability analysis performed in the main program. Elements that do not use material ID's specified in the Material Control Input will not be listed in the reliability analysis. Note that each material in the TEMPLET INP file is arbitrarily ordered: there is no set order for surface or volume flaw analysis, and CARES can alternate between the two. It should be repeated here that when surface or volume flaw analysis is specified, the same material ID in the Material Control Input should be assigned to the appropriate shell and solid elements. The fracture criterion and flaw geometry were arbitrarily chosen for this example.

The temperature-dependent data for the Weibull material parameters were also arbitrarily selected. Weibull material parameters m and σ_0 were directly input at temperature levels of 538 °C (1000 °F), 816 °C (1500 °F), and 1093 °C (2000 °F). These data were repeated in the CARES2 output for each material along with the calculated value of the normalized Batdorf crack density coefficient \bar{k}_B . Since statistical data for more than one temperature level were input, the CARES2 output also lists interpolated material parameters at five intermediate temperatures between each input temperature level. These data are provided so that the user can check the interpolation. If the interpolated values were not reasonable, then additional input data would have been required.

The CARES output is organized such that the echo of the Material Control Input and related statistical analysis and parameter calculation results are output for each material in the order in which they were input by the user. At the end of the output listing, the element reliability tables are generated for the elements having the same material ID's as specified in the Material Control Input via the MATID keyword. If,

for example, statistical material fracture data were provided for volume flow analysis for material ID 300, and corresponding surface flow data were not provided for the shell elements with material ID 300, then reliability analysis would be performed for the solid elements only, even though both element types share the same BULK DATA material cards.

NASTRAN INPUT FILE

```
# USER=_____ PW=_____
# QSUB -r example4 # job name
# QSUB -eo # combine stderr and stdout
# QSUB -lM 1.0mw # set memory limit
# QSUB -lt 00:01:00 # set cpu time limit
set -vKX
cd
cat >ex4nastin<<"EOF"
NASTRAN DAYLIMIT = -1
ID CERAMIC,FRACTURE
APP DISP
SOL 47
TIME 30
CEND
TITLE = THERMOMECHANICALLY LOADED ANNULAR DISK
SUBTITLE = SOLID ELEMENTS WITH CYCLIC SYMMETRY MODELING
SET 2 = 0
HARMONICS =2
SPC=1
LOAD=10
TEMP(LOAD)=11
SET 5= 1
NOUTPUT=5
DISP=ALL
ECHO=PUNCH
STRESS(PRINT,PUNCH)=ALL
OUTPUT(PLOT)
PLOTTER NAST
SET 1=ALL
AXES MX,MY,MZ
PTITLE = THERMOMECHANICALLY LOADED ANNULAR DISK
FIND SCALE,ORIGIN 1,SET 1
PLOT SYMBOLS 5, LABEL BOTH SHAPE
MAXIMUM DEFORMATION
PLOT STATIC DEFORMATION,SET 1
BEGIN BULK
$. . . . .2. . . . .3. . . . .4. . . . .5. . . . .6. . . . .7. . . . .8. . . . .9. . . . .10. . . . .
CQUAD8,130,301,1,27,88,62,18,53,+Q30
+Q30,79,44
CQUAD8,100,301,1,3,29,27,2,19,+Q00
+Q00,28,18
CQUAD8,101,101,3,5,31,29,4,20,+Q01
+Q01,30,19
CQUAD8,102,101,5,7,33,31,6,21,+Q02
+Q02,32,20
CQUAD8,103,101,7,9,35,33,8,22,+Q03
+Q03,34,21
CQUAD8,104,101,9,11,37,35,10,23,+Q04
+Q04,36,22
CQUAD8,105,101,11,13,39,37,12,24,+Q05
+Q05,38,23
CQUAD8,106,101,13,15,41,39,14,25,+Q06
+Q06,40,24
CQUAD8,107,201,15,17,43,41,16,26,+Q07
+Q07,42,25
```

CQUAD8,110,301,62,64,90,88,63,80,+Q11
 +Q11,89,79
 CQUAD8,111,101,64,66,92,90,65,81,+Q10
 +Q10,91,80
 CQUAD8,112,101,66,68,94,92,67,82,+Q12
 +Q12,93,81
 CQUAD8,113,101,68,70,96,94,69,83,+Q13
 +Q13,95,82
 CQUAD8,114,101,70,72,98,96,71,84,+Q14
 +Q14,97,83
 CQUAD8,115,101,72,74,100,98,73,85,+Q15
 +Q15,99,84
 CQUAD8,116,101,74,76,102,100,75,86,+Q16
 +Q16,101,85
 CQUAD8,117,201,76,78,104,102,77,87,+Q17
 +Q17,103,86
 CQUAD8,120,201,17,43,104,78,26,61,+Q20
 +Q20,87,52

CHEXA	1	300	1	3	29	27	62	64	+C11
+C11	90	88	2	19	28	18	44	45	+C12
+C12	54	53	63	80	89	79			
CHEXA	2	100	3	5	31	29	64	66	+C21
+C21	92	90	4	20	30	19	45	46	+C22
+C22	55	54	65	81	91	80			
CHEXA	3	100	5	7	33	31	66	68	+C31
+C31	94	92	6	21	32	20	46	47	+C32
+C32	56	55	67	82	93	81			
CHEXA	4	100	7	9	35	33	68	70	+C41
+C41	96	94	8	22	34	21	47	48	+C42
+C42	57	56	69	83	95	82			
CHEXA	5	100	9	11	37	35	70	72	+C51
+C51	98	96	10	23	36	22	48	49	+C52
+C52	58	57	71	84	97	83			
CHEXA	6	100	11	13	39	37	72	74	+C61
+C61	100	98	12	24	38	23	49	50	+C62
+C62	59	58	73	85	99	84			
CHEXA	7	100	13	15	41	39	74	76	+C71
+C71	102	100	14	25	40	24	50	51	+C72
+C72	60	59	75	86	101	85			
CHEXA	8	200	15	17	43	41	76	78	+C81
+C81	104	102	16	26	42	25	51	52	+C82
+C82	61	60	77	87	103	86			
GRID	1		.25	0.	0.				
GRID	2		.275	0.	0.				
GRID	3		.30	0.	0.				
GRID	4		.35	0.	0.				
GRID	5		.40	0.	0.				
GRID	6		.45	0.	0.				
GRID	7		.50	0.	0.				
GRID	8		.55	0.	0.				
GRID	9		.60	0.	0.				
GRID	10		.65	0.	0.				
GRID	11		.70	0.	0.				
GRID	12		.75	0.	0.				
GRID	13		.80	0.	0.				

GRID	14	.90	0.	0.
GRID	15	1.0	0.	0.
GRID	16	1.3	0.	0.
GRID	17	1.625	0.	0.
GRID	18	.25	7.5	0.
GRID	19	.30	7.5	0.
GRID	20	.40	7.5	0.
GRID	21	.50	7.5	0.
GRID	22	.60	7.5	0.
GRID	23	.70	7.5	0.
GRID	24	.80	7.5	0.
GRID	25	1.0	7.5	0.
GRID	26	1.625	7.5	0.
GRID	27	.25	15.	0.
GRID	28	.275	15.	0.
GRID	29	.30	15.	0.
GRID	30	.35	15.	0.
GRID	31	.40	15.	0.
GRID	32	.45	15.	0.
GRID	33	.50	15.	0.
GRID	34	.55	15.	0.
GRID	35	.60	15.	0.
GRID	36	.65	15.	0.
GRID	37	.70	15.	0.
GRID	38	.75	15.	0.
GRID	39	.80	15.	0.
GRID	40	.90	15.	0.
GRID	41	1.0	15.	0.
GRID	42	1.3	15.	0.
GRID	43	1.625	15.	0.
GRID	44	.25	0.	0.075
GRID	45	.30	0.	0.075
GRID	46	.40	0.	0.075
GRID	47	.50	0.	0.075
GRID	48	.60	0.	0.075
GRID	49	.70	0.	0.075
GRID	50	.80	0.	0.075
GRID	51	1.0	0.	0.075
GRID	52	1.625	0.	0.075
GRID	53	.25	15.	0.075
GRID	54	.30	15.	0.075
GRID	55	.40	15.	0.075
GRID	56	.50	15.	0.075
GRID	57	.60	15.	0.075
GRID	58	.70	15.	0.075
GRID	59	.80	15.	0.075
GRID	60	1.0	15.	0.075
GRID	61	1.625	15.	0.075
GRID	62	.25	0.	0.15
GRID	63	.275	0.	0.15
GRID	64	.30	0.	0.15
GRID	65	.35	0.	0.15
GRID	66	.40	0.	0.15
GRID	67	.45	0.	0.15
GRID	68	.50	0.	0.15

GRID	69		.55	0.	0.15				
GRID	70		.60	0.	0.15				
GRID	71		.65	0.	0.15				
GRID	72		.70	0.	0.15				
GRID	73		.75	0.	0.15				
GRID	74		.80	0.	0.15				
GRID	75		.90	0.	0.15				
GRID	76		1.0	0.	0.15				
GRID	77		1.3	0.	0.15				
GRID	78		1.625	0.	0.15				
GRID	79		.25	7.5	0.15				
GRID	80		.30	7.5	0.15				
GRID	81		.40	7.5	0.15				
GRID	82		.50	7.5	0.15				
GRID	83		.60	7.5	0.15				
GRID	84		.70	7.5	0.15				
GRID	85		.80	7.5	0.15				
GRID	86		1.0	7.5	0.15				
GRID	87		1.625	7.5	0.15				
GRID	88		.25	15.	0.15				
GRID	89		.275	15.	0.15				
GRID	90		.30	15.	0.15				
GRID	91		.35	15.	0.15				
GRID	92		.40	15.	0.15				
GRID	93		.45	15.	0.15				
GRID	94		.50	15.	0.15				
GRID	95		.55	15.	0.15				
GRID	96		.60	15.	0.15				
GRID	97		.65	15.	0.15				
GRID	98		.70	15.	0.15				
GRID	99		.75	15.	0.15				
GRID	100		.80	15.	0.15				
GRID	101		.90	15.	0.15				
GRID	102		1.0	15.	0.15				
GRID	103		1.3	15.	0.15				
GRID	104		1.625	15.	0.15				
CYJOIN	1		1	THRU	17	44	THRU	52	+BC
+BC	62	THRU	78						
CYJOIN	2		27	THRU	43	53	THRU	61	+FG
+FG	88	THRU	104						
SPC1	1	3456	44	THRU	52				
SPC1	1	3456	53	THRU	61				
CORD2C	5	0	0.	0.	0.	0.	0.	1.	+C
+C	1.	90.	0.						
CYSYM	24	ROT							
GRDSET		5				5	456		
PSOLID	100,300,5								
PSOLID	200,301,5								
PSOLID	300,302,5								
PSHELL	101,300,.000001								
PSHELL	201,301,.000001								
PSHELL	301,302,.000001								
MAT1	300,4.19+7,,0.219,3.000-4,5.55-6								
MAT1	301,3.00+6,,0.300,7.331-4,6.66-6								
MAT1	302,3.86+7,,0.250,3.200-4,5.0-6								

TEMPD,20,70.
 TEMP,20, 1,2000., 2,1970., 3,1950.
 TEMP,20, 4,1920., 5,1900., 6,1850.
 TEMP,20, 7,1800., 8,1750., 9,1700.
 TEMP,20, 10,1650., 11,1600., 12,1550.
 TEMP,20, 13,1500., 14,1450., 15,1400.
 TEMP,20, 16,1350., 17,1300.
 TEMP,20, 18,2000., 19,1950., 20,1900.
 TEMP,20, 21,1800., 22,1700., 23,1600.
 TEMP,20, 24,1500., 25,1400., 26,1300.
 TEMP,20, 27,2000., 28,1970., 29,1950.
 TEMP,20, 30,1920., 31,1900., 32,1850.
 TEMP,20, 33,1800., 34,1750., 35,1700.
 TEMP,20, 36,1650., 37,1600., 38,1550.
 TEMP,20, 39,1500., 40,1450., 41,1400.
 TEMP,20, 42,1350., 43,1300.
 TEMP,20, 44,2000., 45,1950., 46,1900.
 TEMP,20, 47,1800., 48,1700., 49,1600.
 TEMP,20, 50,1500., 51,1400., 52,1300.
 TEMP,20, 53,2000., 54,1950., 55,1900.
 TEMP,20, 56,1800., 57,1700., 58,1600.
 TEMP,20, 59,1500., 60,1400., 61,1300.
 TEMP,20, 62,2000., 63,1970., 64,1950.
 TEMP,20, 65,1920., 66,1900., 67,1850.
 TEMP,20, 68,1800., 69,1750., 70,1700.
 TEMP,20, 71,1650., 72,1600., 73,1550.
 TEMP,20, 74,1500., 75,1450., 76,1400.
 TEMP,20, 77,1350., 78,1300.
 TEMP,20, 79,2000., 80,1950., 81,1900.
 TEMP,20, 82,1800., 83,1700., 84,1600.
 TEMP,20, 85,1500., 86,1400., 87,1300.
 TEMP,20, 88,2000., 89,1970., 90,1950.
 TEMP,20, 91,1920., 92,1900., 93,1850.
 TEMP,20, 94,1800., 95,1750., 96,1700.
 TEMP,20, 97,1650., 98,1600., 99,1550.
 TEMP,20,100,1500.,101,1450.,102,1400.
 TEMP,20,103,1350.,104,1300.
 PARAM EST 1
 LOADCYH 10 1.0 0 RFORCE 1.0 30
 LOADCYN,11,1.0,1,,1.0,20
 LOADCYN,11,1.0,2,,1.0,20
 LOADCYN,11,1.0,3,,1.0,20
 LOADCYN,11,1.0,4,,1.0,20
 LOADCYN,11,1.0,5,,1.0,20
 LOADCYN,11,1.0,6,,1.0,20
 LOADCYN,11,1.0,7,,1.0,20
 LOADCYN,11,1.0,8,,1.0,20
 LOADCYN,11,1.0,9,,1.0,20
 LOADCYN,11,1.0,10,,1.0,20
 LOADCYN,11,1.0,11,,1.0,20
 LOADCYN,11,1.0,12,,1.0,20
 LOADCYN,11,1.0,13,,1.0,20
 LOADCYN,11,1.0,14,,1.0,20
 LOADCYN,11,1.0,15,,1.0,20
 LOADCYN,11,1.0,16,,1.0,20

```
LOADCYN,11,1.0,17,,1.0,20
LOADCYN,11,1.0,18,,1.0,20
LOADCYN,11,1.0,19,,1.0,20
LOADCYN,11,1.0,20,,1.0,20
LOADCYN,11,1.0,21,,1.0,20
LOADCYN,11,1.0,22,,1.0,20
LOADCYN,11,1.0,23,,1.0,20
LOADCYN,11,1.0,24,,1.0,20
RFORCE 30          5          50.    0.    0.    1.0    2
ENDDATA
EOF
mscnast in=ex4nast.in
```

CARES TEMPLET INPUT FILE

```
*****
*
* RELIABILITY PREDICTION FOR BRITTLE MATERIAL STRUCTURES *
* --- FAST FRACTURE STATISTICS --- *
*
*****
```

MASTER CONTROL INPUT

TITLE : PROBLEM TITLE (ECHOED IN CARES OUTPUT)

EXAMPLE PROBLEM 4 : THERMOMECHANICALLY LOADED ANNULAR DISK

NE : CONTROL INDEX FOR FINITE ELEMENT POSTPROCESSING

 (DEFAULT: NE = 0)
1 0 : EXPERIMENTAL DATA ANALYSIS ONLY

 1 : MSC/NASTRAN ANALYSIS
 2 : ANSYS ANALYSIS

NMATS : NO. OF MATERIALS FOR SURFACE FLAW ANALYSIS

 (NMATS+NMATV < 101)
02 (DEFAULT: NMATS = 0)

NMATV : NO. OF MATERIALS FOR VOLUME FLAW ANALYSIS

 (NMATS+NMATV < 101)
02 (DEFAULT: NMATV = 0)

IPRINT : CONTROL INDEX FOR STRESS OUTPUT

 (DEFAULT: IPRINT = 0)
1 0 : DO NOT PRINT ELEMENT STRESSES AND/OR FRACTURE DATA

 1 : PRINT ELEMENT STRESSES AND/OR FRACTURE DATA

LONL : CONTROL INDEX FOR LINEAR OR QUADRATIC ELEMENTS

 (DEFAULT: LONL = 0)
1 0 : LINEAR

 1 : QUADRATIC (MIDSIDE NODES REQUIRED)

NGP : NO. OF GAUSSIAN QUADRATURE POINTS (15 OR 30)

 (DEFAULT: NGP = 15)
15

NS : NO. OF SEGMENTS IN CYCLIC SYMMETRY PROBLEM

 (DEFAULT: NS = 1)
024

```
*****
$ENDX : END OF MASTER CONTROL INPUT
*****
```

MATERIAL CONTROL INPUT

TITLE : MATERIAL TITLE (ECHOED IN CARES OUTPUT)

SILICON NITRIDE DATA FOR VOLUME FLAW ANALYSIS

MATID : MATERIAL IDENTIFICATION NO. FROM THE FINITE ELEMENT

MATERIAL PROPERTY CARD (IF POSTPROCESSING IS NOT
0000300 BEING PERFORMED THIS ENTRY SHOULD BE SOME UNIQUE NO.)

(NO DEFAULT)

ID1 : CONTROL INDEX FOR EXPERIMENTAL DATA

(NO DEFAULT)
3 1 : UNIFORM UNIAXIAL TENSILE SPECIMEN TEST DATA

2 : FOUR-POINT BEND TEST DATA
3 : DIRECT INPUT OF THE WEIBULL PARAMETERS, M AND SP
(SHAPE PARAMETER AND SCALE PARAMETER)
4 : CENSORED DATA FOR SUSPENDED ITEM ANALYSIS OF
UNIFORM UNIAXIAL TENSILE SPECIMEN TEST DATA
5 : CENSORED DATA FOR SUSPENDED ITEM ANALYSIS OF
FOUR-POINT BEND TEST DATA

ID4 : CONTROL INDEX FOR VOLUME OR SURFACE FLAW ANALYSIS

(NO DEFAULT)
1 1 : VOLUME

2 : SURFACE

ID2V : CONTROL INDEX FOR VOLUME FRACTURE CRITERION

(NO DEFAULT)
5 1 : NORMAL STRESS FRACTURE CRITERION

(SHEAR-INSENSITIVE CRACK)
2 : MAXIMUM TENSILE STRESS CRITERION
3 : COPLANAR STRAIN ENERGY RELEASE RATE CRITERION
(G SUB T)
4 : WEIBULL PIA MODEL
5 : SHETTY'S SEMI-EMPIRICAL CRITERION

ID3V : CONTROL INDEX FOR SHAPE OF VOLUME CRACKS

(NO DEFAULT)
2 1 : GRIFFITH CRACK

2 : PENNY-SHAPED CRACK

IKBAT : CONTROL INDEX FOR METHOD OF CALCULATING BATDORF CRACK

DENSITY COEFFICIENT (K SUB B) FROM TEST DATA
0 (DEFAULT: IKBAT = 0)

0 : SHEAR-INSENSITIVE METHOD (MODE I FRACTURE ASSUMED)
1 : SHEAR-SENSITIVE METHOD (FRACTURE ASSUMED TO OCCUR
ACCORDING TO THE FRACTURE CRITERION AND CRACK SHAPE
SELECTED BY THE ID2 AND ID3 INDICES)

PR : POISSON'S RATIO

(DEFAULT: PR = 0.25)

00000.2190

C : CONSTANT FOR SHETTY'S SEMI-EMPIRICAL MIXED-MODE FRACTURE
CRITERION $(KI/KIC)+(KII/(C*KIC))^{**2} = 1$

00000.8000 OBSERVED VALUES RANGE FROM 0.8 TO 2. (REF. D.K. SHETTY)

NOTE: AS C APPROACHES INFINITY, PREDICTED FAILURE
PROBABILITIES APPROACH NORMAL STRESS CRITERION VALUES
(DEFAULT C = 1.0)

\$ENDM : END OF TEMPERATURE INDEPENDENT MATERIAL CONTROL INPUT

TEMPERATURE DEPENDENT MATERIAL CONTROL INPUT DATA
FOR THE ABOVE MATERIAL

!!
PLEASE NOTE THE FOLLOWING:
1. TEMPERATURE DEPENDENT DATA SETS MUST BE ARRANGED IN ASCENDING ORDER
ACCORDING TO TEMPERATURE.
2. MAXIMUM NUMBER OF TEMPERATURE SETS IS 20.
!!

TDEG : TEMPERATURE OF THIS SET

01000.0000

PARAM : WEIBULL MODULUS (SHAPE PARAMETER) AND SCALE PARAMETER
-WEIBULL MODULUS---SCALE PARAMETER-*
0.765000E+01 0.558000E+05

END OF DATA FOR THE ABOVE TEMPERATURE

TDEG : TEMPERATURE OF THIS SET

01500.0000

PARAM : WEIBULL MODULUS (SHAPE PARAMETER) AND SCALE PARAMETER
-WEIBULL MODULUS---SCALE PARAMETER-*
0.100000E+02 0.500000E+05

END OF DATA FOR THE ABOVE TEMPERATURE

TDEG : TEMPERATURE OF THIS SET

02000.0000

PARAM : WEIBULL MODULUS (SHAPE PARAMETER) AND SCALE PARAMETER
-WEIBULL MODULUS---SCALE PARAMETER-*
0.120000E+02 0.400000E+05

END OF DATA FOR THE ABOVE TEMPERATURE

\$ENDT : END OF DATA FOR THE ABOVE MATERIAL

MATERIAL CONTROL INPUT

TITLE : MATERIAL TITLE (ECHOED IN CARES OUTPUT)

SILICON NITRIDE DATA FOR SURFACE FLAW ANALYSIS

MATID : MATERIAL IDENTIFICATION NO. FROM THE FINITE ELEMENT
MATERIAL PROPERTY CARD (IF POSTPROCESSING IS NOT
0000300 BEING PERFORMED THIS ENTRY SHOULD BE SOME UNIQUE NO.)
----- (NO DEFAULT)

ID1 : CONTROL INDEX FOR EXPERIMENTAL DATA
(NO DEFAULT)
3

1 : UNIFORM UNIAXIAL TENSILE SPECIMEN TEST DATA
2 : FOUR-POINT BEND TEST DATA
3 : DIRECT INPUT OF THE WEIBULL PARAMETERS, M AND SP
(SHAPE PARAMETER AND SCALE PARAMETER)
4 : CENSORED DATA FOR SUSPENDED ITEM ANALYSIS OF
UNIFORM UNIAXIAL TENSILE SPECIMEN TEST DATA
5 : CENSORED DATA FOR SUSPENDED ITEM ANALYSIS OF
FOUR-POINT BEND TEST DATA

ID4 : CONTROL INDEX FOR VOLUME OR SURFACE FLAW ANALYSIS
(NO DEFAULT)
2

1 : VOLUME
2 : SURFACE

ID2S : CONTROL INDEX FOR SURFACE FRACTURE CRITERION
(NO DEFAULT)
5

1 : NORMAL STRESS FRACTURE CRITERION
(SHEAR-INSENSITIVE CRACK)
3 : COPLANAR STRAIN ENERGY RELEASE RATE CRITERION
(G SUB T)
4 : WEIBULL PIA MODEL
5 : SHETTY'S SEMI-EMPIRICAL CRITERION

ID3S : CONTROL INDEX FOR SHAPE OF SURFACE CRACKS
(NO DEFAULT)
4

1 : GRIFFITH CRACK
(ASSOCIATED WITH STRAIN ENERGY RELEASE RATE CRIT.)
(ASSOCIATED WITH SHETTY'S SEMI-EMPIRICAL CRITERION)
3 : GRIFFITH NOTCH
(ASSOCIATED WITH STRAIN ENERGY RELEASE RATE CRIT.)
(ASSOCIATED WITH SHETTY'S SEMI-EMPIRICAL CRITERION)
4 : SEMICIRCULAR CRACK
(ASSOCIATED WITH SHETTY'S SEMI-EMPIRICAL CRITERION)

IKBAT : CONTROL INDEX FOR METHOD OF CALCULATING BATDORF CRACK
 DENSITY COEFFICIENT (K SUB B) FROM TEST DATA
 0 (DEFAULT: IKBAT = 0)
 0 : SHEAR-INSENSITIVE METHOD (MODE I FRACTURE ASSUMED)
 1 : SHEAR-SENSITIVE METHOD (FRACTURE ASSUMED TO OCCUR
 ACCORDING TO THE FRACTURE CRITERION AND CRACK SHAPE
 SELECTED BY THE ID2 AND ID3 INDICES)

PR : POISSON'S RATIO
 (DEFAULT: PR = 0.25)
 00000.2190

C : CONSTANT FOR SHETTY'S SEMI-EMPIRICAL MIXED-MODE FRACTURE
 CRITERION $(K_I/K_{IC}) + (K_{II}/(C \cdot K_{IC}))^{**2} = 1$
 OBSERVED VALUES RANGE FROM 0.8 TO 2. (REF. D.K. SHETTY)
 NOTE: AS C APPROACHES INFINITY, PREDICTED FAILURE
 PROBABILITIES APPROACH NORMAL STRESS CRITERION VALUES
 (DEFAULT: C = 1.0)

 \$ENDM : END OF TEMPERATURE INDEPENDENT MATERIAL CONTROL INPUT

TEMPERATURE DEPENDENT MATERIAL CONTROL INPUT DATA
 FOR THE ABOVE MATERIAL

!!
 PLEASE NOTE THE FOLLOWING:
 1. TEMPERATURE DEPENDENT DATA SETS MUST BE ARRANGED IN ASCENDING ORDER
 ACCORDING TO TEMPERATURE.
 2. MAXIMUM NUMBER OF TEMPERATURE SETS IS 20.
 !!!

TDEG : TEMPERATURE OF THIS SET
 01000.0000

PARAM : WEIBULL MODULUS (SHAPE PARAMETER) AND SCALE PARAMETER
 *-WEIBULL MODULUS-*SCALE PARAMETER-*
 0.765000E+01 0.778910E+05

 END OF DATA FOR THE ABOVE TEMPERATURE

TDEG : TEMPERATURE OF THIS SET
 01500.0000

PARAM : WEIBULL MODULUS (SHAPE PARAMETER) AND SCALE PARAMETER
 *-WEIBULL MODULUS-*SCALE PARAMETER-*
 0.900000E+01 0.700000E+05

 END OF DATA FOR THE ABOVE TEMPERATURE

TDEG : TEMPERATURE OF THIS SET

02000.0000

PARAM : WEIBULL MODULUS (SHAPE PARAMETER) AND SCALE PARAMETER

-WEIBULL MODULUS--SCALE PARAMETER-

0.100000E+02 0.500000E+05

END OF DATA FOR THE ABOVE TEMPERATURE

\$ENDT : END OF DATA FOR THE ABOVE MATERIAL

MATERIAL CONTROL INPUT

TITLE : MATERIAL TITLE (ECHOED IN CARES OUTPUT)

SILICON CARBIDE DATA FOR VOLUME FLAW ANALYSIS

MATID : MATERIAL IDENTIFICATION NO. FROM THE FINITE ELEMENT

MATERIAL PROPERTY CARD (IF POSTPROCESSING IS NOT

0000302 BEING PERFORMED THIS ENTRY SHOULD BE SOME UNIQUE NO.)

(NO DEFAULT)

ID1 : CONTROL INDEX FOR EXPERIMENTAL DATA

(NO DEFAULT)

3

1 : UNIFORM UNIAXIAL TENSILE SPECIMEN TEST DATA

2 : FOUR-POINT BEND TEST DATA

3 : DIRECT INPUT OF THE WEIBULL PARAMETERS, M AND SP
(SHAPE PARAMETER AND SCALE PARAMETER)

4 : CENSORED DATA FOR SUSPENDED ITEM ANALYSIS OF
UNIFORM UNIAXIAL TENSILE SPECIMEN TEST DATA

5 : CENSORED DATA FOR SUSPENDED ITEM ANALYSIS OF
FOUR-POINT BEND TEST DATA

ID4 : CONTROL INDEX FOR VOLUME OR SURFACE FLAW ANALYSIS

(NO DEFAULT)

1

1 : VOLUME

2 : SURFACE

ID2V : CONTROL INDEX FOR VOLUME FRACTURE CRITERION

(NO DEFAULT)

5

1 : NORMAL STRESS FRACTURE CRITERION
(SHEAR-INSENSITIVE CRACK)

2 : MAXIMUM TENSILE STRESS CRITERION

3 : COPLANAR STRAIN ENERGY RELEASE RATE CRITERION
(G SUB T)

4 : WEIBULL PIA MODEL

5 : SHETTY'S SEMI-EMPIRICAL CRITERION

ID3V : CONTROL INDEX FOR SHAPE OF VOLUME CRACKS

 2 1 : GRIFFITH CRACK
 2 : PENNY-SHAPED CRACK

IKBAT : CONTROL INDEX FOR METHOD OF CALCULATING BATDORF CRACK

 1 DENSITY COEFFICIENT (K SUB B) FROM TEST DATA
 (DEFAULT: IKBAT = 0)
 0 : SHEAR-INSENSITIVE METHOD (MODE I FRACTURE ASSUMED)
 1 : SHEAR-SENSITIVE METHOD (FRACTURE ASSUMED TO OCCUR
 ACCORDING TO THE FRACTURE CRITERION AND CRACK SHAPE
 SELECTED BY THE ID2 AND ID3 INDICES)

PR : POISSON'S RATIO

00000.2500

C : CONSTANT FOR SHETTY'S SEMI-EMPIRICAL MIXED-MODE FRACTURE

 CRITERION $(K_I/K_{IC}) + (K_{II}/(C*K_{IC}))^{**2} = 1$
00002.0000 OBSERVED VALUES RANGE FROM 0.8 TO 2. (REF. D.K. SHETTY)
----- NOTE: AS C APPROACHES INFINITY, PREDICTED FAILURE
 PROBABILITIES APPROACH NORMAL STRESS CRITERION VALUES
 (DEFAULT C = 1.0)

\$ENDM : END OF TEMPERATURE INDEPENDENT MATERIAL CONTROL INPUT

TEMPERATURE DEPENDENT MATERIAL CONTROL INPUT DATA
FOR THE ABOVE MATERIAL

!!
PLEASE NOTE THE FOLLOWING:
1. TEMPERATURE DEPENDENT DATA SETS MUST BE ARRANGED IN ASCENDING ORDER
 ACCORDING TO TEMPERATURE.
2. MAXIMUM NUMBER OF TEMPERATURE SETS IS 20.
!!

TDEG : TEMPERATURE OF THIS SET

01000.0000

PARAM : WEIBULL MODULUS (SHAPE PARAMETER) AND SCALE PARAMETER
-WEIBULL MODULUS--SCALE PARAMETER-
 0.100000E+02 0.650000E+05

END OF DATA FOR THE ABOVE TEMPERATURE

TDEG : TEMPERATURE OF THIS SET

01500.0000

PARAM : WEIBULL MODULUS (SHAPE PARAMETER) AND SCALE PARAMETER
-WEIBULL MODULUS-SCALE PARAMETER-
0.140000E+02 0.600000E+05

END OF DATA FOR THE ABOVE TEMPERATURE

TDEG : TEMPERATURE OF THIS SET

02000.0000

PARAM : WEIBULL MODULUS (SHAPE PARAMETER) AND SCALE PARAMETER
-WEIBULL MODULUS-SCALE PARAMETER-
0.110000E+02 0.530000E+05

END OF DATA FOR THE ABOVE TEMPERATURE

\$ENDT : END OF DATA FOR THE ABOVE MATERIAL

MATERIAL CONTROL INPUT

TITLE : MATERIAL TITLE (ECHOED IN CARES OUTPUT)

SILICON CARBIDE DATA FOR SURFACE FLAW ANALYSIS

MATID : MATERIAL IDENTIFICATION NO. FROM THE FINITE ELEMENT

0000302 MATERIAL PROPERTY CARD (IF POSTPROCESSING IS NOT
----- BEING PERFORMED THIS ENTRY SHOULD BE SOME UNIQUE NO.)
(NO DEFAULT)

ID1 : CONTROL INDEX FOR EXPERIMENTAL DATA

3 (NO DEFAULT)

1 : UNIFORM UNIAXIAL TENSILE SPECIMEN TEST DATA
2 : FOUR-POINT BEND TEST DATA
3 : DIRECT INPUT OF THE WEIBULL PARAMETERS, M AND SP
(SHAPE PARAMETER AND SCALE PARAMETER)
4 : CENSORED DATA FOR SUSPENDED ITEM ANALYSIS OF
UNIFORM UNIAXIAL TENSILE SPECIMEN TEST DATA
5 : CENSORED DATA FOR SUSPENDED ITEM ANALYSIS OF
FOUR-POINT BEND TEST DATA

ID4 : CONTROL INDEX FOR VOLUME OR SURFACE FLAW ANALYSIS

2 (NO DEFAULT)

1 : VOLUME
2 : SURFACE

ID2S : CONTROL INDEX FOR SURFACE FRACTURE CRITERION

5 (NO DEFAULT)

1 : NORMAL STRESS FRACTURE CRITERION
(SHEAR-INSENSITIVE CRACK)
3 : COPLANAR STRAIN ENERGY RELEASE RATE CRITERION
(G SUB T)

4 : WEIBULL PIA MODEL
5 : SHETTY'S SEMI-EMPIRICAL CRITERION

ID3S : CONTROL INDEX FOR SHAPE OF SURFACE CRACKS

 (NO DEFAULT)
 4

 1 : GRIFFITH CRACK
 (ASSOCIATED WITH STRAIN ENERGY RELEASE RATE CRIT.)
 (ASSOCIATED WITH SHETTY'S SEMI-EMPIRICAL CRITERION)
 3 : GRIFFITH NOTCH
 (ASSOCIATED WITH STRAIN ENERGY RELEASE RATE CRIT.)
 (ASSOCIATED WITH SHETTY'S SEMI-EMPIRICAL CRITERION)
 4 : SEMICIRCULAR CRACK
 (ASSOCIATED WITH SHETTY'S SEMI-EMPIRICAL CRITERION)

IKBAT : CONTROL INDEX FOR METHOD OF CALCULATING BATDORF CRACK

 DENSITY COEFFICIENT (K SUB B) FROM TEST DATA
 1

 0 : SHEAR-INSENSITIVE METHOD (MODE I FRACTURE ASSUMED)
 1 : SHEAR-SENSITIVE METHOD (FRACTURE ASSUMED TO OCCUR
 ACCORDING TO THE FRACTURE CRITERION AND CRACK SHAPE
 SELECTED BY THE ID2 AND ID3 INDICES)

PR : POISSON'S RATIO

 (DEFAULT: PR = 0.25)
00000.2500

C : CONSTANT FOR SHETTY'S SEMI-EMPIRICAL MIXED-MODE FRACTURE

 CRITERION $(K_I/K_{IC}) + (K_{II}/(C*K_{IC}))^{**2} = 1$
00000.8000

 OBSERVED VALUES RANGE FROM 0.8 TO 2. (REF. D.K. SHETTY)
 NOTE: AS C APPROACHES INFINITY, PREDICTED FAILURE
 PROBABILITIES APPROACH NORMAL STRESS CRITERION VALUES
 (DEFAULT: C = 1.0)

\$ENDM : END OF TEMPERATURE INDEPENDENT MATERIAL CONTROL INPUT

TEMPERATURE DEPENDENT MATERIAL CONTROL INPUT DATA
FOR THE ABOVE MATERIAL

!!
PLEASE NOTE THE FOLLOWING:
1. TEMPERATURE DEPENDENT DATA SETS MUST BE ARRANGED IN ASCENDING ORDER
 ACCORDING TO TEMPERATURE.
2. MAXIMUM NUMBER OF TEMPERATURE SETS IS 20.
!!

TDEG : TEMPERATURE OF THIS SET

01000.0000

PARAM : WEIBULL MODULUS (SHAPE PARAMETER) AND SCALE PARAMETER
-WEIBULL MODULUS--SCALE PARAMETER-
0.500000E+01 0.700000E+05

END OF DATA FOR THE ABOVE TEMPERATURE

TDEG : TEMPERATURE OF THIS SET

01500.0000

PARAM : WEIBULL MODULUS (SHAPE PARAMETER) AND SCALE PARAMETER
-WEIBULL MODULUS--SCALE PARAMETER-
0.600000E+01 0.750000E+05

END OF DATA FOR THE ABOVE TEMPERATURE

TDEG : TEMPERATURE OF THIS SET

02000.0000

PARAM : WEIBULL MODULUS (SHAPE PARAMETER) AND SCALE PARAMETER
-WEIBULL MODULUS--SCALE PARAMETER-
0.800000E+01 0.550000E+05

END OF DATA FOR THE ABOVE TEMPERATURE

\$ENDT : END OF DATA FOR THE ABOVE MATERIAL

CARES2 OUTPUT FILE

```

@@@@@@@@@@@@@@@@@@@@@@@@@@@@@@@@@@@@@@@@@@@@@@@@@@@@@@@@@@@@@@@@@@@@@@@@@@@@@@@@@@@@@@@@@@@@
@@@@
@@
@@
@@          CCCCCC          A          RRRRRRRR          EEEEEEEEEE          SSSSSSSS
@@         C           C        A  A        R           R        E           S           S
@@        C           C        A  A        R           R        E           S           S
@@       C           C        A  A        RRRRRRRR          EEEEEEEE          SSSSSSSS
@@      C           C        A  A        R           R        E           S           S
@@     C           C        A  A        R           R        EEEEEEEEEE          SSSSSSSS
@@    CCCCCC        A          A          R           R        EEEEEEEEEE          SSSSSSSS
@@
@@
@@          CERAMICS ANALYSIS AND RELIABILITY EVALUATION OF STRUCTURES          @@
@@
@@@@@@@@@@@@@@@@@@@@@@@@@@@@@@@@@@@@@@@@@@@@@@@@@@@@@@@@@@@@@@@@@@@@@@@@@@@@@@@@@@@@@@@@@@@@

```

```

*****
*
*          ECHO OF MASTER CONTROL INPUT          *
*
*****

```

TITLE = EXAMPLE PROBLEM 4 : THERMOMECHANICALLY LOADED ANNULAR DISK

- 1 = CONTROL INDEX FOR FINITE ELEMENT POSTPROCESSING (NE)
 - 0 : EXPERIMENTAL DATA ANALYSIS ONLY
 - 1 : MSC/NASTRAN ANALYSIS
 - 2 : ANSYS ANALYSIS

- 2 = NUMBER OF MATERIALS FOR SURFACE FLAW ANALYSIS (NMATS)

- 2 = NUMBER OF MATERIALS FOR VOLUME FLAW ANALYSIS (NMATV)

- 15 = NUMBER OF GAUSSIAN QUADRATURE POINTS, EITHER 15 OR 30 (NGP)

- 24 = NUMBER OF SEGMENTS IN CYCLIC SYMMETRY PROBLEM (NS)

- 1 = CONTROL INDEX FOR LINEAR OR QUADRATIC ELEMENTS (LONL)
 - 0 : LINEAR (MIDSIDE NODES OPTIONAL)
 - 1 : QUADRATIC (MIDSIDE NODES REQUIRED)

- 1 = CONTROL INDEX FOR STRESS OUTPUT (IPRINT)
 - 0 : DO NOT PRINT ELEMENT STRESSES AND/OR FRACTURE DATA
 - 1 : PRINT ELEMENT STRESSES AND/OR FRACTURE DATA

```
XXXXXXXXXXXXXXXXXXXXXXXXXXXXXXXXXXXXXXXXXXXXXXXXXXXXXXXXXXXX
*
*          ECHO OF FINITE ELEMENT ANALYSIS DATA          *
*                   PROCESSED BY CARES                   *
*
XXXXXXXXXXXXXXXXXXXXXXXXXXXXXXXXXXXXXXXXXXXXXXXXXXXXXXXXXXXX
```

***** RESULTS FROM SEARCH OF MSC/NASTRAN BULK DATA *****

8 = TOTAL NUMBER OF SOLID ELEMENTS FOUND (NE)

8 = NUMBER OF HEXA ELEMENTS (NH)

0 = NUMBER OF PENTA ELEMENTS (NP)

0 = NUMBER OF TRIAX6 AXISYMMETRIC ELEMENTS (NA)

18 = TOTAL NUMBER OF SHELL ELEMENTS (NES)

18 = NUMBER OF QUAD8 SHELL ELEMENTS (NSQ)

0 = NUMBER OF TRIA6 SHELL ELEMENTS (NST)

***** MSC/NASTRAN STRESS ANALYSIS OUTPUT *****

\$TITLE = THERMOMECHANICALLY LOADED ANNULAR DISK
 \$SUBTITLE= SOLID ELEMENTS WITH CYCLIC SYMMETRY MODELING

--- PRINCIPAL STRESSES AT THE CENTER OF EACH SUBELEMENT OR ELEMENT ---

\$ELEMENT TYPE = 67

HEXA ELEMENT OUTPUT

ELEMENT	PRC. STRESS I	PRC. STRESS II	PRC. STRESS III
1	-0.6502945979E+03	-0.4732389115E+04	-0.4275111072E+05
	-0.2438978352E+04	-0.2943711729E+04	-0.4275110435E+05
	-0.6502945979E+03	-0.4732389115E+04	-0.4275111072E+05
	0.9724649568E+04	-0.4218041052E+04	-0.3453128752E+05
	0.9465417000E+04	-0.3958854516E+04	-0.3453124148E+05
	0.9724649568E+04	-0.4218041052E+04	-0.3453128752E+05
	0.2305052029E+05	-0.6652951731E+04	-0.2631313213E+05
	0.2187454573E+05	-0.5477455273E+04	-0.2631265403E+05
	0.2305052029E+05	-0.6652951731E+04	-0.2631313213E+05
	-0.7786670058E+03	-0.4825822382E+04	-0.4252930504E+05
	-0.2660777659E+04	-0.2943711729E+04	-0.4252930504E+05
	-0.7786670058E+03	-0.4825822382E+04	-0.4252930504E+05
	0.9719663894E+04	-0.4366787894E+04	-0.3437755500E+05
	0.9465417000E+04	-0.4112541000E+04	-0.3437755500E+05
	0.9719663894E+04	-0.4366787894E+04	-0.3437755500E+05
	0.2303822780E+05	-0.6727986411E+04	-0.2622580496E+05
	0.2187454573E+05	-0.5564304341E+04	-0.2622580496E+05
	0.2303822780E+05	-0.6727986411E+04	-0.2622580496E+05
	-0.6502945979E+03	-0.4732389115E+04	-0.4275111072E+05
	-0.2438978352E+04	-0.2943711729E+04	-0.4275110435E+05
	-0.6502945979E+03	-0.4732389115E+04	-0.4275111072E+05
	0.9724649568E+04	-0.4218041052E+04	-0.3453128752E+05
	0.9465417000E+04	-0.3958854516E+04	-0.3453124148E+05
	0.9724649568E+04	-0.4218041052E+04	-0.3453128752E+05
	0.2305052029E+05	-0.6652951731E+04	-0.2631313213E+05
	0.2187454573E+05	-0.5477455273E+04	-0.2631265403E+05
	0.2305052029E+05	-0.6652951731E+04	-0.2631313213E+05
2	-0.1838210464E+04	-0.2019644975E+05	-0.7402597195E+05
	-0.2038968719E+04	-0.1999573988E+05	-0.7402592357E+05
	-0.1838210464E+04	-0.2019644975E+05	-0.7402597195E+05
	-0.5760545278E+04	-0.1149944728E+05	-0.6258271829E+05
	-0.5760640448E+04	-0.1149935950E+05	-0.6258271090E+05
	-0.5760545278E+04	-0.1149944728E+05	-0.6258271829E+05
	-0.2458312111E+04	-0.1002648595E+05	-0.5113999147E+05
	-0.3002979124E+04	-0.9481827729E+04	-0.5113998268E+05
	-0.2458312111E+04	-0.1002648595E+05	-0.5113999147E+05
	-0.2204067217E+04	-0.2019879656E+05	-0.7365776839E+05
	-0.2407123899E+04	-0.1999573988E+05	-0.7365776839E+05
	-0.2204067217E+04	-0.2019879656E+05	-0.7365776839E+05
	-0.6038534882E+04	-0.1149947097E+05	-0.6230470500E+05
	-0.6038646350E+04	-0.1149935950E+05	-0.6230470500E+05
	-0.6038534882E+04	-0.1149947097E+05	-0.6230470500E+05
	-0.2474503901E+04	-0.1019864402E+05	-0.5095164161E+05
	-0.3002979124E+04	-0.9670168801E+04	-0.5095164161E+05
	-0.2474503901E+04	-0.1019864402E+05	-0.5095164161E+05
	-0.1838210464E+04	-0.2019644975E+05	-0.7402597195E+05
	-0.2038968719E+04	-0.1999573988E+05	-0.7402592357E+05
	-0.1838210464E+04	-0.2019644975E+05	-0.7402597195E+05
	-0.5760545278E+04	-0.1149944728E+05	-0.6258271829E+05
	-0.5760640448E+04	-0.1149935950E+05	-0.6258271090E+05
	-0.5760545278E+04	-0.1149944728E+05	-0.6258271829E+05
	-0.2458312111E+04	-0.1002648595E+05	-0.5113999147E+05
	-0.3002979124E+04	-0.9481827729E+04	-0.5113998268E+05
	-0.2458312111E+04	-0.1002648595E+05	-0.5113999147E+05

ELEMENT	PRC. STRESS I	PRC. STRESS II	PRC. STRESS III
3	-0.2205213863E+03	-0.1806274374E+05	-0.4264434910E+05
	-0.2597725189E+03	-0.1802349583E+05	-0.4264434588E+05
	-0.2205213863E+03	-0.1806274374E+05	-0.4264434910E+05
	0.2094463761E+03	-0.1897341692E+05	-0.3371565121E+05
	0.1925032500E+03	-0.1895647476E+05	-0.3371565024E+05
	0.2094463761E+03	-0.1897341692E+05	-0.3371565121E+05
	0.6492715844E+03	-0.1989386996E+05	-0.2478703089E+05
	0.6447790189E+03	-0.1988937742E+05	-0.2478703087E+05
	0.6492715844E+03	-0.1989386996E+05	-0.2478703089E+05
	-0.2210904043E+03	-0.1823721211E+05	-0.4246931171E+05
	-0.2597725189E+03	-0.1819853000E+05	-0.4246931171E+05
	-0.2210904043E+03	-0.1823721211E+05	-0.4246931171E+05
	0.2092652803E+03	-0.1907639203E+05	-0.3361249500E+05
	0.1925032500E+03	-0.1905963000E+05	-0.3361249500E+05
	0.2092652803E+03	-0.1907639203E+05	-0.3361249500E+05
	0.6492342383E+03	-0.1992518522E+05	-0.2475567829E+05
	0.6447790189E+03	-0.1992073000E+05	-0.2475567829E+05
	0.6492342383E+03	-0.1992518522E+05	-0.2475567829E+05
	-0.2205213863E+03	-0.1806274374E+05	-0.4264434910E+05
	-0.2597725189E+03	-0.1802349583E+05	-0.4264434588E+05
	-0.2205213863E+03	-0.1806274374E+05	-0.4264434910E+05
	0.2094463761E+03	-0.1897341692E+05	-0.3371565121E+05
	0.1925032500E+03	-0.1895647476E+05	-0.3371565024E+05
	0.2094463761E+03	-0.1897341692E+05	-0.3371565121E+05
	0.6492715844E+03	-0.1989386996E+05	-0.2478703089E+05
	0.6447790189E+03	-0.1988937742E+05	-0.2478703087E+05
	J.6492715844E+03	-0.1989386996E+05	-0.2478703089E+05
4	0.4515226636E+03	-0.1714568179E+05	-0.2138628730E+05
	0.4514694839E+03	-0.1714568058E+05	-0.2138623532E+05
	0.4515226636E+03	-0.1714568179E+05	-0.2138628730E+05
	0.3427267475E+03	-0.1012058747E+05	-0.2078406642E+05
	0.3427204500E+03	-0.1012058140E+05	-0.2078406620E+05
	0.3427267475E+03	-0.1012058747E+05	-0.2078406642E+05
	0.2340567565E+03	-0.3094139834E+04	-0.2018332480E+05
	0.2339714161E+03	-0.3094096584E+04	-0.2018328271E+05
	0.2340567565E+03	-0.3094139834E+04	-0.2018332480E+05
	0.4515204740E+03	-0.1716059757E+05	-0.2137136933E+05
	0.4514694839E+03	-0.1716059757E+05	-0.2137131834E+05
	0.4515204740E+03	-0.1716059757E+05	-0.2137136933E+05
	0.3427205702E+03	-0.1018129260E+05	-0.2072335512E+05
	0.3427204500E+03	-0.1018129260E+05	-0.2072335500E+05
	0.3427205702E+03	-0.1018129260E+05	-0.2072335512E+05
	0.2340162509E+03	-0.3201987632E+04	-0.2007543650E+05
	0.2339714161E+03	-0.3201987632E+04	-0.2007539166E+05
	0.2340162509E+03	-0.3201987632E+04	-0.2007543650E+05
	0.4515226636E+03	-0.1714568179E+05	-0.2138628730E+05
	0.4514694839E+03	-0.1714568058E+05	-0.2138623532E+05
	0.4515226636E+03	-0.1714568179E+05	-0.2138628730E+05
	0.3427267475E+03	-0.1012058747E+05	-0.2078406642E+05
	0.3427204500E+03	-0.1012058140E+05	-0.2078406620E+05
	0.3427267475E+03	-0.1012058747E+05	-0.2078406642E+05
	0.2340567565E+03	-0.3094139834E+04	-0.2018332480E+05
	0.2339714161E+03	-0.3094096584E+04	-0.2018328271E+05
	0.2340567565E+03	-0.3094139834E+04	-0.2018332480E+05
5	0.3671919558E+04	0.2616532714E+03	-0.1889925153E+05
	0.3671829269E+04	0.2616802501E+03	-0.1889918822E+05
	0.3671919558E+04	0.2616532714E+03	-0.1889925153E+05
	0.9953672774E+04	0.2432735690E+03	-0.1754237674E+05
	0.9953616862E+04	0.2431929500E+03	-0.1754224021E+05
	0.9953672774E+04	0.2432735690E+03	-0.1754237674E+05
	0.1623548542E+05	0.2249004379E+03	-0.1618556795E+05
	0.1623543273E+05	0.2247056499E+03	-0.1618532047E+05
	0.1623548542E+05	0.2249004379E+03	-0.1618556795E+05
	0.3523936052E+04	0.2617385542E+03	-0.1875135331E+05
	0.3523936052E+04	0.2616802501E+03	-0.1875129501E+05
	0.3523936052E+04	0.2617385542E+03	-0.1875135331E+05
	0.9769621650E+04	0.2433195544E+03	-0.1735837160E+05

ELEMENT	PRC. STRESS I	PRC. STRESS II	PRC. STRESS III
5	0.9769621650E+04	0.2431929500E+03	-0.1735824500E+05
	0.9769621650E+04	0.2433195544E+03	-0.1735837160E+05
	0.1601530725E+05	0.2249363704E+03	-0.1596542571E+05
	0.1601530725E+05	0.2247056499E+03	-0.1596519499E+05
	0.1601530725E+05	0.2249363704E+03	-0.1596542571E+05
	0.3671919558E+04	0.2616532714E+03	-0.1889925153E+05
	0.3671829269E+04	0.2616802501E+03	-0.1889918822E+05
	0.3671919558E+04	0.2616532714E+03	-0.1889925153E+05
	0.9953672774E+04	0.2432735690E+03	-0.1754237674E+05
	0.9953616862E+04	0.2431929500E+03	-0.1754224021E+05
	0.9953672774E+04	0.2432735690E+03	-0.1754237674E+05
	0.1623548542E+05	0.2249004379E+03	-0.1618556795E+05
	0.1623543273E+05	0.2247056499E+03	-0.1618532047E+05
	0.1623548542E+05	0.2249004379E+03	-0.1618556795E+05
6	0.2237707149E+05	0.6016988374E+03	-0.1469440712E+05
	0.2237702595E+05	0.5973712460E+03	-0.1469003399E+05
	0.2237707149E+05	0.6016988374E+03	-0.1469440712E+05
	0.2840319185E+05	0.1395031677E+04	-0.1292968158E+05
	0.2840316288E+05	0.1394485950E+04	-0.1292910688E+05
	0.2840319185E+05	0.1395031677E+04	-0.1292968158E+05
	0.3442932556E+05	0.2206061520E+04	-0.1118266639E+05
	0.3442930671E+05	0.2191600654E+04	-0.1116818667E+05
	0.3442932556E+05	0.2206061520E+04	-0.1118266639E+05
	0.2212787997E+05	0.6016989044E+03	-0.1444521567E+05
	0.2212787997E+05	0.5973712460E+03	-0.1444088801E+05
	0.2212787997E+05	0.6016989044E+03	-0.1444521567E+05
	0.2812318000E+05	0.1395098154E+04	-0.1264973620E+05
	0.2812318000E+05	0.1394485950E+04	-0.1264912400E+05
	0.2812318000E+05	0.1395098154E+04	-0.1264973620E+05
	0.3411848003E+05	0.2206460343E+04	-0.1087221968E+05
	0.3411848003E+05	0.2191600654E+04	-0.1085735999E+05
	0.3411848003E+05	0.2206460343E+04	-0.1087221968E+05
	0.2237707149E+05	0.6016988374E+03	-0.1469440712E+05
	0.2237702595E+05	0.5973712460E+03	-0.1469003399E+05
	0.2237707149E+05	0.6016988374E+03	-0.1469440712E+05
	0.2840319185E+05	0.1395031677E+04	-0.1292968158E+05
	0.2840316288E+05	0.1394485950E+04	-0.1292910688E+05
	0.2840319185E+05	0.1395031677E+04	-0.1292968158E+05
	0.3442932556E+05	0.2206061520E+04	-0.1118266639E+05
	0.3442930671E+05	0.2191600654E+04	-0.1116818667E+05
	0.3442932556E+05	0.2206061520E+04	-0.1118266639E+05
7	0.3952396654E+05	0.4709752260E+04	-0.9785640036E+04
	0.3952394111E+05	0.4669669143E+04	-0.9745531481E+04
	0.3952396654E+05	0.4709752260E+04	-0.9785640036E+04
	0.4443293627E+05	0.9486911246E+04	-0.6428849018E+04
	0.4443292139E+05	0.9481989500E+04	-0.6423912393E+04
	0.4443293627E+05	0.9486911246E+04	-0.6428849018E+04
	0.4934295651E+05	0.1429662031E+05	-0.3105658594E+04
	0.4934294624E+05	0.1429430986E+05	-0.3103337863E+04
	0.4934295651E+05	0.1429662031E+05	-0.3105658594E+04
	0.3921069498E+05	0.4710149928E+04	-0.9472766135E+04
	0.3921069498E+05	0.4669669143E+04	-0.9432285350E+04
	0.3921069498E+05	0.4710149928E+04	-0.9472766135E+04
	0.4408230500E+05	0.9486934814E+04	-0.6078241314E+04
	0.4408230500E+05	0.9481989500E+04	-0.6073296000E+04
	0.4408230500E+05	0.9486934814E+04	-0.6078241314E+04
	0.4895391502E+05	0.1429670467E+05	-0.2716701466E+04
	0.4895391502E+05	0.1429430986E+05	-0.2714306650E+04
	0.4895391502E+05	0.1429670467E+05	-0.2716701466E+04
	0.3952396654E+05	0.4709752260E+04	-0.9785640036E+04
	0.3952394111E+05	0.4669669143E+04	-0.9745531481E+04
	0.3952396654E+05	0.4709752260E+04	-0.9785640036E+04
	0.4443293627E+05	0.9486911246E+04	-0.6428849018E+04
	0.4443292139E+05	0.9481989500E+04	-0.6423912393E+04
	0.4443293627E+05	0.9486911246E+04	-0.6428849018E+04
	0.4934295651E+05	0.1429662031E+05	-0.3105658594E+04

ELEMENT	PRC. STRESS I	PRC. STRESS II	PRC. STRESS III
7	0.4934294624E+05 0.4934295651E+05	0.1429430986E+05 0.1429662031E+05	-0.3103337863E+04 -0.3105658594E+04
8	-0.1386363143E+04 -0.1396028803E+04 -0.1386363143E+04 -0.1268753282E+04 -0.1270884599E+04 -0.1268753282E+04 -0.4080154250E+03 -0.4080154320E+03 -0.4080154250E+03 -0.1392954089E+04 -0.1402572834E+04 -0.1392954089E+04 -0.1269139966E+04 -0.1271262500E+04 -0.1269139966E+04 -0.4150079943E+03 -0.4150079943E+03 -0.4150079943E+03 -0.1386363143E+04 -0.1396028803E+04 -0.1386363143E+04 -0.1268753282E+04 -0.1270884599E+04 -0.1268753282E+04 -0.4080154250E+03 -0.4080154320E+03 -0.4080154250E+03	-0.2705401087E+04 -0.2705403237E+04 -0.2705401087E+04 -0.1557307490E+04 -0.1557311501E+04 -0.1557307490E+04 -0.1144891958E+04 -0.1146944728E+04 -0.1144891958E+04 -0.2698859206E+04 -0.2698859206E+04 -0.2698859206E+04 -0.1556933600E+04 -0.1556933600E+04 -0.1556933600E+04 -0.1137933433E+04 -0.1139952166E+04 -0.1137933433E+04 -0.2705401087E+04 -0.2705403237E+04 -0.2705401087E+04 -0.1557307490E+04 -0.1557311501E+04 -0.1557307490E+04 -0.1144891958E+04 -0.1146944728E+04 -0.1144891958E+04	-0.4986274816E+04 -0.4976607007E+04 -0.4986274816E+04 -0.3577452328E+04 -0.3575317000E+04 -0.3577452328E+04 -0.2176079770E+04 -0.2174026993E+04 -0.2176079770E+04 -0.4986225752E+04 -0.4976607007E+04 -0.4986225752E+04 -0.3577439534E+04 -0.3575317000E+04 -0.3577439534E+04 -0.2176045726E+04 -0.2174026993E+04 -0.2176045726E+04 -0.4986274816E+04 -0.4976607007E+04 -0.4986274816E+04 -0.3577452328E+04 -0.3575317000E+04 -0.3577452328E+04 -0.2176079770E+04 -0.2174026993E+04 -0.2176079770E+04

\$ELEMENT TYPE = 64

QUAD8 ELEMENT OUTPUT

ELEMENT	PRC. STRESS I	PRC. STRESS II
100	-0.2060171437E+03 -0.2093858048E+03 -0.2060171437E+03 -0.5917266502E+04 -0.5921143500E+04 -0.5917266502E+04 -0.1162797323E+05 -0.1163290120E+05 -0.1162797323E+05	-0.4041578035E+05 -0.4041241169E+05 -0.4041578035E+05 -0.3632647200E+05 -0.3632259500E+05 -0.3632647200E+05 -0.3223770628E+05 -0.3223277831E+05 -0.3223770628E+05
101	0.5501957421E+04 0.5501191364E+04 0.5501957421E+04 -0.6946794193E+03 -0.6949320000E+03 -0.6946794193E+03 -0.6891054900E+04 -0.6891055364E+04 -0.6891054900E+04	-0.6592809610E+05 -0.6592733005E+05 -0.6592809610E+05 -0.5689378258E+05 -0.5689353000E+05 -0.5689378258E+05 -0.4785973042E+05 -0.4785972995E+05 -0.4785973042E+05
102	-0.1759592934E+05 -0.1759603666E+05 -0.1759592934E+05 -0.1870519980E+05 -0.1870550000E+05 -0.1870519980E+05	-0.4186322070E+05 -0.4186311338E+05 -0.4186322070E+05 -0.3306165020E+05 -0.3306130000E+05 -0.3306165020E+05

ELEMENT	PRC. STRESS I	PRC. STRESS II
102	-0.1981321002E+05 -0.1981506334E+05 -0.1981321002E+05	-0.2426133994E+05 -0.2425948662E+05 -0.2426133994E+05
103	-0.1694767148E+05 -0.1695018255E+05 -0.1694767148E+05 -0.9883181183E+04 -0.9884467550E+04 -0.9883181183E+04 -0.2817773622E+04 -0.2818752548E+04 -0.2817773622E+04	-0.2157149774E+05 -0.2156898667E+05 -0.2157149774E+05 -0.2096048637E+05 -0.2095920000E+05 -0.2096048637E+05 -0.2035039226E+05 -0.2034941333E+05 -0.2035039226E+05
104	0.3778816401E+04 0.3778893969E+04 0.3778816401E+04 0.1007653072E+05 0.1007566040E+05 0.1007653072E+05 0.1637426710E+05 0.1637342683E+05 0.1637426710E+05	-0.1926534411E+05 -0.1926442167E+05 -0.1926534411E+05 -0.1791195532E+05 -0.1791108500E+05 -0.1791195532E+05 -0.1655858860E+05 -0.1655774833E+05 -0.1655858860E+05
105	0.2233672524E+05 0.2233584164E+05 0.2233672524E+05 0.2815114496E+05 0.2815024500E+05 0.2815114496E+05 0.3396556772E+05 0.3396464836E+05 0.3396556772E+05	-0.1533955695E+05 -0.1533867334E+05 -0.1533955695E+05 -0.1380417996E+05 -0.1380328000E+05 -0.1380417996E+05 -0.1226880602E+05 -0.1226788666E+05 -0.1226880602E+05
106	0.3821573492E+05 0.3821545498E+05 0.3821573492E+05 0.4177223889E+05 0.4177222500E+05 0.4177223889E+05 0.4532954985E+05 0.4532899502E+05 0.4532954985E+05	-0.1138575845E+05 -0.1138547851E+05 -0.1138575845E+05 -0.9434329392E+04 -0.9434315500E+04 -0.9434329392E+04 -0.7483707323E+04 -0.7483152490E+04 -0.7483707323E+04
107	0.7407260335E+03 0.7407200691E+03 0.7407260335E+03 0.2617075623E+03 0.2616048000E+03 0.2617075623E+03 0.6677473135E+03 0.6676329360E+03 0.6677473135E+03	-0.4134605005E+03 -0.4134545360E+03 -0.4134605005E+03 0.1269864377E+03 0.1270892000E+03 0.1269864377E+03 -0.2176248465E+03 -0.2175104691E+03 -0.2176248465E+03
110	-0.2060171437E+03 -0.2093858048E+03 -0.2060171437E+03 -0.5917266502E+04 -0.5921143500E+04 -0.5917266502E+04 -0.1162797323E+05 -0.1163290120E+05 -0.1162797323E+05	-0.4041578035E+05 -0.4041241169E+05 -0.4041578035E+05 -0.3632647200E+05 -0.3632259500E+05 -0.3632647200E+05 -0.3223770628E+05 -0.3223277831E+05 -0.3223770628E+05
111	0.5501957421E+04 0.5501191364E+04 0.5501957421E+04 -0.6946794193E+03 -0.6949320000E+03	-0.6592809610E+05 -0.6592733005E+05 -0.6592809610E+05 -0.5689378258E+05 -0.5689353000E+05

ELEMENT	PRC. STRESS I	PRC. STRESS II
111	-0.6946794193E+03	-0.5689378258E+05
	-0.6891054900E+04	-0.4785973042E+05
	-0.6891055364E+04	-0.4785972995E+05
	-0.6891054900E+04	-0.4785973042E+05
112	-0.1759592934E+05	-0.4186322070E+05
	-0.1759603666E+05	-0.4186311338E+05
	-0.1759592934E+05	-0.4186322070E+05
	-0.1870519980E+05	-0.3306165020E+05
	-0.1870555000E+05	-0.3306130000E+05
	-0.1870519980E+05	-0.3306165020E+05
	-0.1981321002E+05	-0.2426133994E+05
	-0.1981506334E+05	-0.2425948662E+05
	-0.1981321002E+05	-0.2426133994E+05
	113	-0.1694767148E+05
-0.1695018255E+05		-0.2156898667E+05
-0.1694767148E+05		-0.2157149774E+05
-0.9883181183E+04		-0.2096048637E+05
-0.9884467550E+04		-0.2095920000E+05
-0.9883181183E+04		-0.2096048637E+05
-0.2817773622E+04		-0.2035039226E+05
-0.2818752548E+04		-0.2034941333E+05
-0.2817773622E+04		-0.2035039226E+05
114		0.3778816401E+04
	0.3777893969E+04	-0.1926442167E+05
	0.3778816401E+04	-0.1926534411E+05
	0.1007653072E+05	-0.1791195532E+05
	0.1007566040E+05	-0.1791108500E+05
	0.1007653072E+05	-0.1791195532E+05
	0.1637426710E+05	-0.1655858860E+05
	0.1637342683E+05	-0.1655774833E+05
	0.1637426710E+05	-0.1655858860E+05
	115	0.2233672524E+05
0.2233584164E+05		-0.1533867334E+05
0.2233672524E+05		-0.1533955695E+05
0.2815114496E+05		-0.1380417996E+05
0.2815024500E+05		-0.1380328000E+05
0.2815114496E+05		-0.1380417996E+05
0.3396556772E+05		-0.1226880602E+05
0.3396464836E+05		-0.1226788666E+05
0.3396556772E+05		-0.1226880602E+05
116		0.3821573492E+05
	0.3821545498E+05	-0.1138547851E+05
	0.3821573492E+05	-0.1138575845E+05
	0.4177223889E+05	-0.9434329392E+04
	0.4177222500E+05	-0.9434315500E+04
	0.4177223889E+05	-0.9434329392E+04
	0.4532954985E+05	-0.7483707323E+04
	0.4532899502E+05	-0.7483152490E+04
	0.4532954985E+05	-0.7483707323E+04
	117	0.7407260335E+03
0.7407200691E+03		-0.4134545360E+03
0.7407260335E+03		-0.4134605005E+03
0.2617075623E+03		0.1269864377E+03
0.2616048000E+03		0.1270892000E+03
0.2617075623E+03		0.1269864377E+03
0.6677473135E+03		-0.2176248465E+03
0.6676329360E+03		-0.2175104691E+03
0.6677473135E+03		-0.2176248465E+03
120		0.6398246868E+03
	0.6398246000E+03	-0.1003473000E+04
	0.6398246868E+03	-0.1003473087E+04
	0.6398246000E+03	-0.1003473000E+04

ELEMENT	PRC. STRESS I	PRC. STRESS II
120	0.6398246000E+03	-0.1003473000E+04
	0.6398246000E+03	-0.1003473000E+04
	0.6398246868E+03	-0.1003473087E+04
	0.6398246000E+03	-0.1003473000E+04
	0.6398246868E+03	-0.1003473087E+04
130	-0.7964701296E+04	-0.4377296170E+05
	-0.7964703000E+04	-0.4377296000E+05
	-0.7964701296E+04	-0.4377296170E+05
	-0.7964703000E+04	-0.4377296000E+05
	-0.7964703000E+04	-0.4377296000E+05
	-0.7964703000E+04	-0.4377296000E+05
	-0.7964701296E+04	-0.4377296170E+05
	-0.7964703000E+04	-0.4377296000E+05
	-0.7964701296E+04	-0.4377296170E+05

--- CROSS REFERENCE TABLE FOR SHELL ELEMENTS ---

SHELL ELT. NO.	SOLID ELT. NO.
100	1
101	2
102	3
103	4
104	5
105	6
106	7
107	8
110	1
111	2
112	3
113	4
114	5
115	6
116	7
117	8
120	8
130	1

--- CROSS REFERENCE TABLE FOR SOLID ELEMENTS ---

SOLID ELT. NO.	SHELL ELT. NOS.		
1	100	110	130
2	101	111	
3	102	112	
4	103	113	
5	104	114	
6	105	115	
7	106	116	
8	107	117	120

--- VOLUME AND TEMPERATURE OF EACH SOLID ELEMENT ---

ELEMENT NO.	VOLUME	AVE. TEMP.
1	0.5338E-03	0.1974E+04
2	0.1359E-02	0.1924E+04
3	0.1747E-02	0.1850E+04
4	0.2135E-02	0.1750E+04
5	0.2523E-02	0.1650E+04
6	0.2912E-02	0.1550E+04
7	0.6988E-02	0.1450E+04
8	0.3185E-01	0.1350E+04

--- AREA AND TEMPERATURE OF EACH SHELL ELEMENT ---

ELEMENT NO.	AREA	AVE. TEMP.
100	0.3600E-02	0.1974E+04
101	0.9163E-02	0.1924E+04
102	0.1178E-01	0.1850E+04
103	0.1440E-01	0.1750E+04
104	0.1702E-01	0.1650E+04
105	0.1963E-01	0.1550E+04
106	0.4712E-01	0.1450E+04
107	0.2148E+00	0.1350E+04
110	0.3600E-02	0.1974E+04
111	0.9163E-02	0.1924E+04
112	0.1178E-01	0.1850E+04
113	0.1440E-01	0.1750E+04
114	0.1702E-01	0.1650E+04
115	0.1963E-01	0.1550E+04
116	0.4712E-01	0.1450E+04
117	0.2148E+00	0.1350E+04
120	0.6381E-01	0.1300E+04
130	0.9817E-02	0.2000E+04

```
*****
*
*           ECHO OF MATERIAL CONTROL INPUT           *
*
*****
```

TITLE = SILICON NITRIDE DATA FOR VOLUME FLAW ANALYSIS

300 = MATERIAL IDENTIFICATION NUMBER (MATID)

1 = CONTROL INDEX FOR VOLUME OR SURFACE FLAW ANALYSIS (ID4)
1 : VOLUME
2 : SURFACE

3 = CONTROL INDEX FOR EXPERIMENTAL DATA (ID1)
1 : UNIFORM UNIAXIAL TENSILE SPECIMEN TEST DATA
2 : FOUR-POINT BEND TEST DATA
3 : DIRECT INPUT OF THE WEIBULL PARAMETERS, M AND SP
(SHAPE PARAMETER AND SCALE PARAMETER)
4 : CENSORED DATA FOR SUSPENDED ITEM ANALYSIS OF
UNIFORM UNIAXIAL TENSILE SPECIMEN TEST DATA
5 : CENSORED DATA FOR SUSPENDED ITEM ANALYSIS OF
FOUR-POINT BEND TEST DATA

5 = CONTROL INDEX FOR VOLUME FRACTURE CRITERION (ID2V)
1 : NORMAL STRESS FRACTURE CRITERION
(SHEAR-INSENSITIVE CRACK)
2 : MAXIMUM TENSILE STRESS CRITERION
3 : COPLANAR STRAIN ENERGY RELEASE RATE CRITERION
4 : WEIBULL PIA MODEL
5 : SHETTY'S SEMI-EMPIRICAL CRITERION

2 = CONTROL INDEX FOR SHAPE OF VOLUME CRACKS (ID3V)
1 : GRIFFITH CRACK
2 : PENNY-SHAPED CRACK

0 = CONTROL INDEX FOR METHOD OF CALCULATING BATDORF CRACK DENSITY COEFFICIENT
(K SUB B) FROM TEST DATA (KIBAT)
0 : SHEAR-INSENSITIVE METHOD (MODE I FRACTURE ASSUMED)
1 : SHEAR-SENSITIVE METHOD (FRACTURE ASSUMED TO OCCUR
ACCORDING TO THE FRACTURE CRITERION AND CRACK
SHAPE SELECTED BY THE ID2 AND ID3 INDICES)

0.8000 = CONSTANT FOR SHETTY'S SEMI-EMPIRICAL FRACTURE CRITERION (C)
 $(K_I/K_{IC}) + ((K_{II} \text{ OR } K_{III}) / (C * K_{IC}))^{*2} = 1$
OBSERVED VALUES RANGE FROM .8 TO 2. (REF. D. K. SHETTY)
NOTE: AS C APPROACHES INFINITY PREDICTED FAILURE
PROBABILITIES APPROACH NORMAL STRESS CRITERION

0.2190 = POISSON'S RATIO (PR)

```

*****
*                                     *
*           VOLUME FLAW PARAMETER ANALYSIS           *
*                                     *
*****

```

*** BATDORF MODEL --- CRACK ORIENTATION, CRACK SHAPE, AND FRACTURE CRITERION ARE CONSIDERED ***

--- TEMPERATURE DEPENDENT MATERIAL PARAMETERS FOR MATERIAL NUMBER 300

WEIBULL MODULUS (SHAPE PARAMETER), M (DIMENSIONLESS)
 NORMALIZED BATDORF CRACK DENSITY COEFFICIENT, K (DIMENSIONLESS)
 SCALE PARAMETER, SP (UNITS OF STRESS*VOLUME**(1/M))

TEMPERATURE	M	K	SP
1000.0000	0.7650E+01	0.1630E+02	0.5580E+05
1050.0000	0.7901E+01	0.1680E+02	0.5541E+05
1150.0000	0.8392E+01	0.1778E+02	0.5450E+05
1250.0000	0.8869E+01	0.1874E+02	0.5343E+05
1350.0000	0.9332E+01	0.1966E+02	0.5218E+05
1450.0000	0.9781E+01	0.2056E+02	0.5077E+05
1500.0000	0.1000E+02	0.2100E+02	0.5000E+05
1550.0000	0.1022E+02	0.2143E+02	0.4919E+05
1650.0000	0.1064E+02	0.2227E+02	0.4744E+05
1750.0000	0.1104E+02	0.2309E+02	0.4553E+05
1850.0000	0.1144E+02	0.2387E+02	0.4344E+05
1950.0000	0.1182E+02	0.2463E+02	0.4119E+05
2000.0000	0.1200E+02	0.2500E+02	0.4000E+05

FRACTURE CRITERION = $(K_I/K_{IC}) + ((K_{II} \text{ OR } K_{III}) / (C * K_{IC}))^2 = 1$ WHERE C = 0.8000E+00
 CRACK SHAPE = PENNY-SHAPED CRACK

```

XXXXXXXXXXXXXXXXXXXXXXXXXXXXXXXXXXXXXXXXXXXXXXXXXXXXXXXXXXXX
X
X          ECHO OF MATERIAL CONTROL INPUT          X
X
XXXXXXXXXXXXXXXXXXXXXXXXXXXXXXXXXXXXXXXXXXXXXXXXXXXXXXXXXXXX

```

TITLE = SILICON NITRIDE DATA FOR SURFACE FLAW ANALYSIS

300 = MATERIAL IDENTIFICATION NUMBER (MATID)

2 = CONTROL INDEX FOR VOLUME OR SURFACE FLAW ANALYSIS (ID4)
 1 : VOLUME
 2 : SURFACE

3 = CONTROL INDEX FOR EXPERIMENTAL DATA (ID1)
 1 : UNIFORM UNIAXIAL TENSILE SPECIMEN TEST DATA
 2 : FOUR-POINT BEND TEST DATA
 3 : DIRECT INPUT OF THE WEIBULL PARAMETERS, M AND SP
 (SHAPE PARAMETER AND SCALE PARAMETER)
 4 : CENSORED DATA FOR SUSPENDED ITEM ANALYSIS OF
 UNIFORM UNIAXIAL TENSILE SPECIMEN TEST DATA
 5 : CENSORED DATA FOR SUSPENDED ITEM ANALYSIS OF
 FOUR-POINT BEND TEST DATA

5 = CONTROL INDEX FOR SURFACE FRACTURE CRITERION (ID2S)
 1 : NORMAL STRESS FRACTURE CRITERION
 (SHEAR-INSENSITIVE CRACK)
 3 : COPLANAR STRAIN ENERGY RELEASE RATE CRITERION
 4 : WEIBULL PIA MODEL
 5 : SHETTY'S SEMI-EMPIRICAL CRITERION

4 = CONTROL INDEX FOR SHAPE OF SURFACE CRACKS (ID3S)
 1 : GRIFFITH CRACK
 (ASSOCIATED WITH STRAIN ENERGY RELEASE RATE CRITERION)
 (ASSOCIATED WITH SHETTY'S SEMI-EMPIRICAL CRITERION)
 3 : GRIFFITH NOTCH
 (ASSOCIATED WITH STRAIN ENERGY RELEASE RATE CRITERION)
 (ASSOCIATED WITH SHETTY'S SEMI-EMPIRICAL CRITERION)
 4 : SEMICIRCULAR CRACK
 (ASSOCIATED WITH SHETTY'S SEMI-EMPIRICAL CRITERION)

0 = CONTROL INDEX FOR METHOD OF CALCULATING BATDORF CRACK DENSITY COEFFICIENT
 (K SUB B) FROM TEST DATA (IKBAT)
 0 : SHEAR-INSENSITIVE METHOD (MODE I FRACTURE ASSUMED)
 1 : SHEAR-SENSITIVE METHOD (FRACTURE ASSUMED TO OCCUR
 ACCORDING TO THE FRACTURE CRITERION AND CRACK
 SHAPE SELECTED BY THE ID2 AND ID3 INDICES)

0.8000 = CONSTANT FOR SHETTY'S SEMI-EMPIRICAL FRACTURE CRITERION (C)
 $(K_I/K_{IC}) + ((K_{II} \text{ OR } K_{III}) / (C * K_{IC}))^2 = 1$
 OBSERVED VALUES RANGE FROM .8 TO 2. (REF. D. K. SHETTY)
 NOTE: AS C APPROACHES INFINITY PREDICTED FAILURE
 PROBABILITIES APPROACH NORMAL STRESS CRITERION

0.2190 = POISSON'S RATIO (PR)

```

*****
*
*          SURFACE FLAW PARAMETER ANALYSIS          *
*
*****

```

*** BATDORF MODEL --- CRACK ORIENTATION, CRACK SHAPE, AND FRACTURE CRITERION ARE CONSIDERED ***

--- TEMPERATURE DEPENDENT MATERIAL PARAMETERS FOR MATERIAL NUMBER 300

WEIBULL MODULUS (SHAPE PARAMETER), M (DIMENSIONLESS)
 NORMALIZED BATDORF CRACK DENSITY COEFFICIENT, K (DIMENSIONLESS)
 SCALE PARAMETER, SP (UNITS OF STRESS*AREA**(1/M))

TEMPERATURE	M	K	SP
1000.0000	0.7650E+01	0.4986E+01	0.7789E+05
1050.0000	0.7801E+01	0.5033E+01	0.7765E+05
1150.0000	0.8092E+01	0.5122E+01	0.7680E+05
1250.0000	0.8369E+01	0.5206E+01	0.7546E+05
1350.0000	0.8632E+01	0.5286E+01	0.7364E+05
1450.0000	0.8881E+01	0.5360E+01	0.7133E+05
1500.0000	0.9000E+01	0.5396E+01	0.7000E+05
1550.0000	0.9116E+01	0.5430E+01	0.6854E+05
1650.0000	0.9337E+01	0.5494E+01	0.6527E+05
1750.0000	0.9544E+01	0.5554E+01	0.6151E+05
1850.0000	0.9737E+01	0.5608E+01	0.5727E+05
1950.0000	0.9916E+01	0.5658E+01	0.5254E+05
2000.0000	0.1000E+02	0.5681E+01	0.5000E+05

FRACTURE CRITERION = (KI/KIC)+((KII OR KIII)/(C*KIC))**2 = 1 WHERE C = 0.8000E+00
 CRACK SHAPE = SEMICIRCULAR CRACK

```

*****
*
*           ECHO OF MATERIAL CONTROL INPUT           *
*
*****

```

TITLE = SILICON CARBIDE DATA FOR VOLUME FLAW ANALYSIS

302 = MATERIAL IDENTIFICATION NUMBER (MATID)

1 = CONTROL INDEX FOR VOLUME OR SURFACE FLAW ANALYSIS (ID4)
 1 : VOLUME
 2 : SURFACE

3 = CONTROL INDEX FOR EXPERIMENTAL DATA (ID1)
 1 : UNIFORM UNIAXIAL TENSILE SPECIMEN TEST DATA
 2 : FOUR-POINT BEND TEST DATA
 3 : DIRECT INPUT OF THE WEIBULL PARAMETERS, M AND SP
 (SHAPE PARAMETER AND SCALE PARAMETER)
 4 : CENSORED DATA FOR SUSPENDED ITEM ANALYSIS OF
 UNIFORM UNIAXIAL TENSILE SPECIMEN TEST DATA
 5 : CENSORED DATA FOR SUSPENDED ITEM ANALYSIS OF
 FOUR-POINT BEND TEST DATA

5 = CONTROL INDEX FOR VOLUME FRACTURE CRITERION (ID2V)
 1 : NORMAL STRESS FRACTURE CRITERION
 (SHEAR-INSENSITIVE CRACK)
 2 : MAXIMUM TENSILE STRESS CRITERION
 3 : COPLANAR STRAIN ENERGY RELEASE RATE CRITERION
 4 : WEIBULL PIA MODEL
 5 : SHETTY'S SEMI-EMPIRICAL CRITERION

2 = CONTROL INDEX FOR SHAPE OF VOLUME CRACKS (ID3V)
 1 : GRIFFITH CRACK
 2 : PENNY-SHAPED CRACK

1 = CONTROL INDEX FOR METHOD OF CALCULATING BATDORF CRACK DENSITY COEFFICIENT
 (K SUB B) FROM TEST DATA (IKBAT)
 0 : SHEAR-INSENSITIVE METHOD (MODE I FRACTURE ASSUMED)
 1 : SHEAR-SENSITIVE METHOD (FRACTURE ASSUMED TO OCCUR
 ACCORDING TO THE FRACTURE CRITERION AND CRACK
 SHAPE SELECTED BY THE ID2 AND ID3 INDICES)

2.0000 = CONSTANT FOR SHETTY'S SEMI-EMPIRICAL FRACTURE CRITERION (C)
 $(K_I/K_{IC}) + ((K_{II} \text{ OR } K_{III}) / (C * K_{IC}))^{*2} = 1$
 OBSERVED VALUES RANGE FROM .8 TO 2. (REF. D. K. SHETTY)
 NOTE: AS C APPROACHES INFINITY PREDICTED FAILURE
 PROBABILITIES APPROACH NORMAL STRESS CRITERION

0.2500 = POISSON'S RATIO (PR)

```

*****
*
*           VOLUME FLAW PARAMETER ANALYSIS           *
*
*****

```

*** BATDORF MODEL --- CRACK ORIENTATION, CRACK SHAPE, AND FRACTURE CRITERION ARE CONSIDERED ***

--- TEMPERATURE DEPENDENT MATERIAL PARAMETERS FOR MATERIAL NUMBER 302

WEIBULL MODULUS (SHAPE PARAMETER), M (DIMENSIONLESS)
 NORMALIZED BATDORF CRACK DENSITY COEFFICIENT, K (DIMENSIONLESS)
 SCALE PARAMETER, SP (UNITS OF STRESS*VOLUME**(1/M))

TEMPERATURE	M	K	SP
1000.0000	0.1000E+02	0.1443E+02	0.6500E+05
1050.0000	0.1071E+02	0.1540E+02	0.6459E+05
1150.0000	0.1193E+02	0.1704E+02	0.6371E+05
1250.0000	0.1288E+02	0.1831E+02	0.6275E+05
1350.0000	0.1353E+02	0.1920E+02	0.6171E+05
1450.0000	0.1391E+02	0.1971E+02	0.6059E+05
1500.0000	0.1400E+02	0.1982E+02	0.6000E+05
1550.0000	0.1401E+02	0.1984E+02	0.5939E+05
1650.0000	0.1383E+02	0.1960E+02	0.5811E+05
1750.0000	0.1338E+02	0.1898E+02	0.5675E+05
1850.0000	0.1263E+02	0.1798E+02	0.5531E+05
1950.0000	0.1161E+02	0.1661E+02	0.5379E+05
2000.0000	0.1100E+02	0.1578E+02	0.5300E+05

FRACTURE CRITERION = (KI/KIC)+((KII OR KIII)/(C*KIC))**2 = 1 WHERE C = 0.2000E+01
 CRACK SHAPE = PENNY-SHAPED CRACK

```

XXXXXXXXXXXXXXXXXXXXXXXXXXXXXXXXXXXXXXXXXXXXXXXXXXXXXXXXXXXX
X
X          ECHO OF MATERIAL CONTROL INPUT          X
X
XXXXXXXXXXXXXXXXXXXXXXXXXXXXXXXXXXXXXXXXXXXXXXXXXXXXXXXXXXXX

```

TITLE = SILICON CARBIDE DATA FOR SURFACE FLAW ANALYSIS

302 = MATERIAL IDENTIFICATION NUMBER (MATID)

2 = CONTROL INDEX FOR VOLUME OR SURFACE FLAW ANALYSIS (ID4)
 1 : VOLUME
 2 : SURFACE

3 = CONTROL INDEX FOR EXPERIMENTAL DATA (ID1)
 1 : UNIFORM UNIAXIAL TENSILE SPECIMEN TEST DATA
 2 : FOUR-POINT BEND TEST DATA
 3 : DIRECT INPUT OF THE WEIBULL PARAMETERS, M AND SP
 (SHAPE PARAMETER AND SCALE PARAMETER)
 4 : CENSORED DATA FOR SUSPENDED ITEM ANALYSIS OF
 UNIFORM UNIAXIAL TENSILE SPECIMEN TEST DATA
 5 : CENSORED DATA FOR SUSPENDED ITEM ANALYSIS OF
 FOUR-POINT BEND TEST DATA

5 = CONTROL INDEX FOR SURFACE FRACTURE CRITERION (ID2S)
 1 : NORMAL STRESS FRACTURE CRITERION
 (SHEAR-INSENSITIVE CRACK)
 3 : COPLANAR STRAIN ENERGY RELEASE RATE CRITERION
 4 : WEIBULL PIA MODEL
 5 : SHETTY'S SEMI-EMPIRICAL CRITERION

4 = CONTROL INDEX FOR SHAPE OF SURFACE CRACKS (ID3S)
 1 : GRIFFITH CRACK
 (ASSOCIATED WITH STRAIN ENERGY RELEASE RATE CRITERION)
 (ASSOCIATED WITH SHETTY'S SEMI-EMPIRICAL CRITERION)
 3 : GRIFFITH NOTCH
 (ASSOCIATED WITH STRAIN ENERGY RELEASE RATE CRITERION)
 (ASSOCIATED WITH SHETTY'S SEMI-EMPIRICAL CRITERION)
 4 : SEMICIRCULAR CRACK
 (ASSOCIATED WITH SHETTY'S SEMI-EMPIRICAL CRITERION)

1 = CONTROL INDEX FOR METHOD OF CALCULATING BATDORF CRACK DENSITY COEFFICIENT
 (K SUB B) FROM TEST DATA (IKBAT)
 0 : SHEAR-INSENSITIVE METHOD (MODE I FRACTURE ASSUMED)
 1 : SHEAR-SENSITIVE METHOD (FRACTURE ASSUMED TO OCCUR
 ACCORDING TO THE FRACTURE CRITERION AND CRACK
 SHAPE SELECTED BY THE ID2 AND ID3 INDICES)

0.8000 = CONSTANT FOR SHETTY'S SEMI-EMPIRICAL FRACTURE CRITERION (C)
 $(K_I/K_{IC}) + ((K_{II} \text{ OR } K_{III}) / (C * K_{IC}))^2 = 1$
 OBSERVED VALUES RANGE FROM .8 TO 2. (REF. D. K. SHETTY)
 NOTE: AS C APPROACHES INFINITY PREDICTED FAILURE
 PROBABILITIES APPROACH NORMAL STRESS CRITERION

0.2500 = POISSON'S RATIO (PR)

```

XXXXXXXXXXXXXXXXXXXXXXXXXXXXXXXXXXXXXXXXXXXXXXXXXXXXXXXXXXXX
X
X          SURFACE FLAW PARAMETER ANALYSIS          X
X
XXXXXXXXXXXXXXXXXXXXXXXXXXXXXXXXXXXXXXXXXXXXXXXXXXXXXXXXXXXX

```

*** BATDORF MODEL --- CRACK ORIENTATION, CRACK SHAPE, AND FRACTURE CRITERION ARE CONSIDERED ***

--- TEMPERATURE DEPENDENT MATERIAL PARAMETERS FOR MATERIAL NUMBER 302

WEIBULL MODULUS (SHAPE PARAMETER), M (DIMENSIONLESS)
 NORMALIZED BATDORF CRACK DENSITY COEFFICIENT, K (DIMENSIONLESS)
 SCALE PARAMETER, SP (UNITS OF STRESS*AREA**(1/M))

TEMPERATURE	M	K	SP
1000.0000	0.5000E+01	0.1918E+01	0.7000E+05
1050.0000	0.5055E+01	0.1923E+01	0.7162E+05
1150.0000	0.5195E+01	0.1934E+01	0.7412E+05
1250.0000	0.5375E+01	0.1946E+01	0.7563E+05
1350.0000	0.5595E+01	0.1959E+01	0.7612E+05
1450.0000	0.5855E+01	0.1973E+01	0.7562E+05
1500.0000	0.6000E+01	0.1981E+01	0.7500E+05
1550.0000	0.6155E+01	0.1989E+01	0.7412E+05
1650.0000	0.6495E+01	0.2005E+01	0.7162E+05
1750.0000	0.6875E+01	0.2023E+01	0.6813E+05
1850.0000	0.7295E+01	0.2042E+01	0.6362E+05
1950.0000	0.7755E+01	0.2061E+01	0.5812E+05
2000.0000	0.8000E+01	0.2072E+01	0.5500E+05

FRACTURE CRITERION = (KI/KIC)+((KII OR KIII)/(C*KIC))**2 = 1 WHERE C = 0.8000E+00
 CRACK SHAPE = SEMICIRCULAR CRACK

```

*****
*                                     *
*          VOLUME FLAW RELIABILITY ANALYSIS          *
*                                     *
*****

```

NOTE: THE ELEMENT SURVIVAL AND FAILURE PROBABILITIES TAKE INTO ACCOUNT THE NUMBER OF SEGMENTS (NS)..

--- ELEMENT CALCULATIONS ---

ELEMENT	MATID	SURVIVAL PROB.	FAILURE PROB.	RISK	RUP. INT.	M	K	SP
1	302	0.1000D+01	0.2148D-06	0.1677D-04	0.1133D+02	0.1622D+02	0.5341D+05	
2	300	0.1000D+01	0.0000D+00	0.0000D+00	0.1172D+02	0.2444D+02	0.4179D+05	
3	300	0.1000D+01	0.0000D+00	0.0000D+00	0.1144D+02	0.2387D+02	0.4344D+05	
4	300	0.1000D+01	0.0000D+00	0.0000D+00	0.1104D+02	0.2309D+02	0.4553D+05	
5	300	0.1000D+01	0.4400D-04	0.7266D-03	0.1064D+02	0.2227D+02	0.4744D+05	
6	300	0.9836D+00	0.1640D-01	0.2366D+00	0.1022D+02	0.2143D+02	0.4919D+05	
7	300	0.4986D+00	0.5014D+00	0.4150D+01	0.9781D+01	0.2056D+02	0.5077D+05	

SORTED MAXIMUM RISK OF RUPTURE INTENSITIES AND CORRESPONDING ELEMENT NUMBERS

ELEMENT	RISK RUP. INT.
7	0.4150D+01
6	0.2366D+00
5	0.7266D-03
1	0.1677D-04

FOR F.E. MODEL VOLUME --- PROBABILITY OF FAILURE = 0.5096D+00
 PROBABILITY OF SURVIVAL = 0.4904D+00

```

*****
*                                     *
*          SURFACE FLAW RELIABILITY ANALYSIS          *
*                                     *
*****

```

NOTE: THE ELEMENT SURVIVAL AND FAILURE PROBABILITIES TAKE INTO ACCOUNT THE NUMBER OF SEGMENTS (NS).

--- ELEMENT CALCULATIONS ---

ELEMENT	MATID	SURVIVAL PROB.	FAILURE PROB.	RISK	RUP. INT.	M	K	SP
100	302	0.1000D+01	0.0000D+00	0.0000D+00	0.7870D+01	0.2066D+01	0.5667D+05	
101	300	0.1000D+01	0.0000D+00	0.0000D+00	0.9870D+01	0.5645D+01	0.5383D+05	
102	300	0.1000D+01	0.0000D+00	0.0000D+00	0.9737D+01	0.5608D+01	0.5727D+05	
103	300	0.1000D+01	0.0000D+00	0.0000D+00	0.9544D+01	0.5554D+01	0.6151D+05	
104	300	0.1000D+01	0.6122D-05	0.1499D-04	0.9337D+01	0.5494D+01	0.6527D+05	
105	300	0.9986D+00	0.1417D-02	0.3009D-02	0.9116D+01	0.5430D+01	0.6854D+05	
106	300	0.9636D+00	0.3644D-01	0.3282D-01	0.8881D+01	0.5360D+01	0.7133D+05	
110	302	0.1000D+01	0.0000D+00	0.0000D+00	0.7870D+01	0.2066D+01	0.5667D+05	
111	300	0.1000D+01	0.0000D+00	0.0000D+00	0.9870D+01	0.5645D+01	0.5383D+05	
112	300	0.1000D+01	0.0000D+00	0.0000D+00	0.9737D+01	0.5608D+01	0.5727D+05	
113	300	0.1000D+01	0.0000D+00	0.0000D+00	0.9544D+01	0.5554D+01	0.6151D+05	
114	300	0.1000D+01	0.6122D-05	0.1499D-04	0.9337D+01	0.5494D+01	0.6527D+05	
115	300	0.9986D+00	0.1417D-02	0.3009D-02	0.9116D+01	0.5430D+01	0.6854D+05	
116	300	0.9636D+00	0.3644D-01	0.3282D-01	0.8881D+01	0.5360D+01	0.7133D+05	
130	302	0.1000D+01	0.0000D+00	0.0000D+00	0.8000D+01	0.2072D+01	0.5500D+05	

SORTED MAXIMUM RISK OF RUPTURE INTENSITIES AND CORRESPONDING ELEMENT NUMBERS

ELEMENT	RISK RUP. INT.
106	0.3282D-01
116	0.3282D-01
105	0.3009D-02
115	0.3009D-02
104	0.1499D-04
114	0.1499D-04

FOR F.E. MODEL SURFACE --- PROBABILITY OF FAILURE = 0.7419D-01
PROBABILITY OF SURVIVAL = 0.9258D+00

```
*****  
*  
*          OVERALL COMPONENT STATISTICS          *  
*  
*****
```

COMPONENT FAILURE PROBABILITY = 0.5460D+00
COMPONENT SURVIVAL PROBABILITY = 0.4540D+00

Example 5—Shear-Sensitive Calculation of the Batdorf Crack Density Coefficient

The previous examples have primarily illustrated results obtained with the parameter $I_{KBAT} = 0$: that is, the normal stress fracture criterion was used to calculate the Batdorf crack density coefficient, regardless of the fracture criterion used in the subsequent reliability calculations. This method was exercised by researchers at the University of Washington (refs. 41, 53, and 54). It is based on the assumption that mode I, rather than mixed-mode, fracture occurs in uniaxial tension because a sufficient number of cracks exist such that at least one large flaw is perpendicular to the load. Alternatively, the Batdorf coefficient can be computed by assuming that the fracture criterion and crack shape selected for multiaxial stress states are also valid for test specimens subjected to uniaxial stress. This approach has been adopted by Shetty, Rosenfield, and Duckworth (refs. 26 and 59) and is implemented in CARES by setting $I_{KBAT} = 1$. These two techniques produce different trends in failure probabilities calculated by the shear-sensitive fracture criteria: the first procedure yields a higher failure probability than the normal stress criterion, whereas the second one results in a lower failure probability than the normal stress criterion. These trends are a reflection of the different values of the crack density coefficient, as shown in table XI.

The first two examples demonstrate that a more conservative failure criterion than the normal stress criterion is necessary for correlation of the predictions with the experimental data. Thus, the shear-insensitive value of k_B was employed in those examples. In addition, stress amplification factors (ref. 13) were previously used to accentuate the material's sensitivity to surface defects and, thus, to better correlate the normal stress criterion results. However, experimental data do not universally exhibit higher failure probabilities than the normal stress criterion predictions. Several explanations exist for the opposing trends of conservatism versus nonconservatism of the normal stress criterion. First, poor experimental techniques, including not performing fractography to separate surface flaw from volume flaw failures, not checking for possible material anisotropy due to processing or machining, or not cutting test specimens from the component, could all lead to dubious results. Furthermore, various materials may behave differently under multiaxial stresses because of diverse flaw types.

Experimental data gathered by Shetty et al. (ref. 60) require the application of a less conservative failure criterion than the normal stress criterion. The strength tests performed were similar to those done at the University of Washington (refs. 41, 53, and 54) and described in **Example 1—Transversely Loaded Circular Disk**. Alumina disks on a ball bearing support ring were subjected to uniform pressure over their entire surface. The disks were 2.5 mm (0.098 in.) thick and 31.75 mm (1.25 in.) in diameter, and were supported along a circle of radius 12.7 mm (0.5 in.). Four-point bend tests were conducted on bars cut from the same billets as the disks.

TABLE XI.—FAILURE PROBABILITIES OF A TRANSVERSELY LOADED CIRCULAR DISK—SURFACE FLAW ANALYSIS

[$m_S = 23.8$; $\sigma_{oS} = 242 \text{ MPa(m)}^{2/23.8}$ (432 $\text{MPa(mm)}^{2/23.8}$, 47 800 $\text{psi(in.)}^{2/23.8}$); $NGP = 15$; $I_{KBAT} = 1$; CARES2 results.]

Fracture stress		Applied pressure		Failure probability		
MPa	ksi	MPa	ksi	Normal stress criterion ^a	Shetty criterion ^b	Experimental data (ref. 60)
300	43.51	12.11	1.756	0.0161	0.0026	0.0041
325	47.14	13.12	1.903	.1036	.0177	.0238
350	50.76	14.13	2.049	.4717	.0988	.1156
375	54.39	15.14	2.196	.9630	.4157	.4291
400	58.02	16.15	2.342	1.0000	.9176	.9016

^a $k_{BS} = 8.725$.

^bGriffith crack; $\bar{C} = 0.8165$; $k_{BS} = 1.416$.

Microscopic examination revealed that all fractures originated on the surface. The Weibull parameters as determined by Shetty from the flexural data are $m_S = 23.8$ and $\sigma_{oS} = 242 \text{ MPa(m)}^{2/m_S}$ (47 800 $\text{psi(in.)}^{2/m_S}$). Shetty used simple plate theory stresses in conjunction with the Weibull normal stress method and the PIA approach to predict strength distributions for the disks. The experimental results showed unusual behavior in that the PIA model was conservative (predicted higher failure probabilities than were observed). The normal stress predictions were also more conservative than the data, as would be expected since this method is more conservative than the PIA technique (ref. 46).

The same data were subsequently analyzed by Lamon (ref. 61), who used the Multiaxial Elemental Strength (MUEST) model. His results display excellent agreement with the published disk data. Lamon employs the maximum strain energy release rate criterion G_{\max} with a Griffith crack. He maintains that the MUEST model is superior to the Batdorf model, citing both qualitative and quantitative reasons. The qualitative reasons given in the paper display an incomplete understanding of the Batdorf model which, although different in its formulation, is based on the same principles as the MUEST model. In fact, a recent state-of-the-art survey (ref. 62) classifies Lamon's work as a Batdorf design methodology. The quantitative premise for rejecting the Batdorf model is simply the fact that the MUEST model agreed with the data and the Batdorf model did not. However, the Batdorf calculations shown are derived from a coplanar strain energy release rate criterion as opposed to the maximum strain energy release rate criterion used in the MUEST model. Furthermore, the Batdorf curves depicted in reference 61 are plotted against data from reference 60, but the calculations are taken from reference 59, in which the support circle radius is 15.24 mm (0.6 in.) rather than 12.7 mm (0.5 in.).

To resolve these inconsistencies, a CARES2 reliability analysis was performed. The finite element mesh from example 1

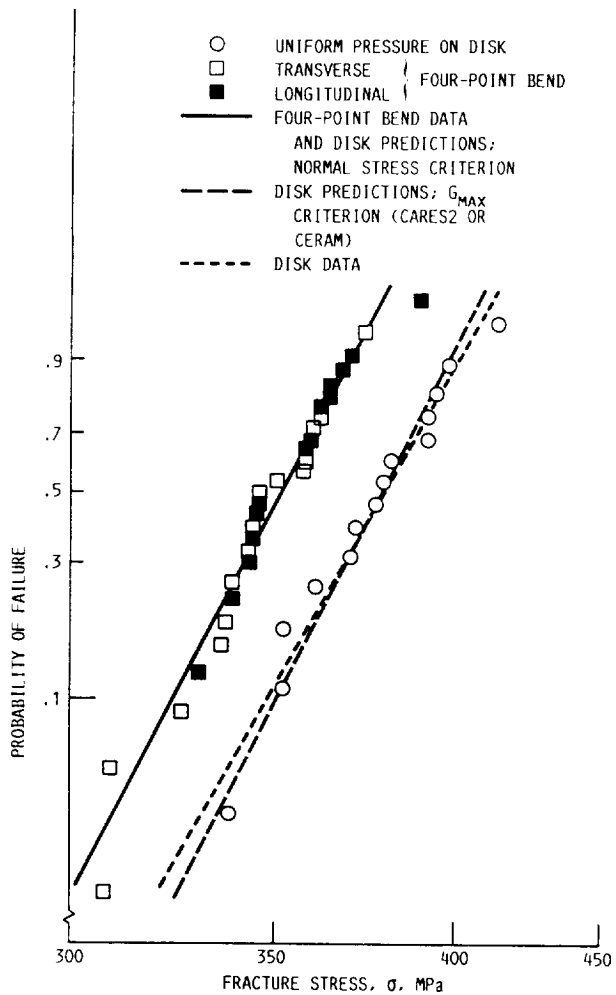

Figure 23.—CARES2 surface flaw analysis failure probability predictions for transversely loaded alumina disks (experimental data from ref. 60).

was modified to represent Shetty's disk as described in reference 60. The plate theory equations given in that same paper were used to calculate the NASTRAN applied pressures corresponding to fracture stress values. CARES surface flaw analysis was executed in accordance with the observed fracture origins. Shetty's semi-empirical fracture criterion with $\bar{C} = 0.8165$ was utilized to simulate the maximum strain energy release rate criterion (ref. 26), and Griffith cracks were chosen for consistency with Lamon's work. The shear-sensitive value of \bar{k}_{BS} (IKBAT = 1) was used for this fracture criterion. The normal stress criterion, for which crack shape is irrelevant, was also employed as reference criterion. For the normal stress criterion, the value of \bar{k}_{BS} is not affected by the selection of IKBAT = 0 or 1. Selected details of the NASTRAN and CARES2 inputs and outputs are given at the end of this example. The results of the reliability analysis are presented in table XI and figure 23. Additional experimental values of P_{fS} were calculated from the observed Weibull modulus of 22 and the disk characteristic strength of 385 MPa (5.58×10^4 psi). The normal stress criterion curve is lower than the one shown in reference 60 because the finite element stress solution and the plate theory solution do not match. The finite element solution is believed to be correct for the same reasons as given in example 1. Excellent correlation exists between the CARES2 mixed-mode predictions and the experimental data. There is also no discernible difference between Lamon's (ref. 61) results and the CARES predictions for this selected crack shape and fracture criterion. Therefore, with the choice of IKBAT = 1, the Griffith crack, and $\bar{C} = 0.8165$ (the G_{max} criterion) in Shetty's mixed-mode fracture equation, the CARES program duplicates predictions of the Battelle CERAM code (Battelle Memorial Institute, Geneva, Switzerland) (ref. 63). This choice of parameters, of course, is just one of the many representations of the fracture problem available to the user in the more general CARES program.

NASTRAN INPUT FILE

```

# USER=_____ PW=_____
# QSUB -r ex5375 # job name
# QSUB -eo # combine stderr and stdout
# QSUB -1M 1.0mw # set memory limit
# QSUB -1t 00:00:30 # set cpu time limit
set -vkk
cd
cat >ex5375<<"EOF"
NASTRAN DAYLIMIT = -1
ID CERAMIC,FRACTURE
APP DISP
SOL 47
TIME 30
CEND
TITLE = STRESS ANALYSIS OF SHETTY'S SIMPLY SUPPORTED DISK
SUBTITLE = UNIFORM PRESSURE LOAD --SUPPORT RADIUS=12.7MM
SET 2 = 0
HARMONICS =2
SPC=1
LOAD=10
SET 5= 1
NOUTPUT=5
DISP=ALL
STRESS(PRINT,PUNCH)=ALL
ECHO=PUNCH
BEGIN BULK
$. . . . .2. . . . .3. . . . .4. . . . .5. . . . .6. . . . .7. . . . .8. . . . .9. . . . .10. . . . .
CPENTA 1 100 1 3 33 73 75 105 PE1
+E1 2 22 32 52 53 63 74 94 PE1A
+E1A 104
CTRIA6,41,101,1,3,33,2,22,32
CHEXA 2 100 3 5 35 33 75 77 HE2
+E2 107 105 4 23 34 22 53 54 HE2A
+E2A 64 63 76 95 106 94
CQUAD8,42,101,3,5,35,33,4,23,CQ1
+Q1,34,22
CQUAD8,43,101,5,7,37,35,6,24,CQ2
+Q2,36,23
CQUAD8,44,101,7,9,39,37,8,25,CQ3
+Q3,38,24
CQUAD8,45,101,9,11,41,39,10,26,CQ4
+Q4,40,25
CQUAD8,46,101,11,13,43,41,12,27,CQ5
+Q5,42,26
CQUAD8,47,101,13,15,45,43,14,28,CQ6
+Q6,44,27
CQUAD8,48,101,15,17,47,45,16,29,CQ7
+Q7,46,28
CQUAD8,49,101,17,19,49,47,18,30,CQ8
+Q8,48,29
CQUAD8,50,101,19,21,51,49,20,31,CQ9
+Q9,50,30
PSHELL,101,300,.000001
CHEXA 3 100 5 7 37 35 77 79 HE3
+E3 109 107 6 24 36 23 54 55 HE3A

```

+E3A	65	64	78	96	108	95			
CHEXA	4	100	7	9	39	37	79	81	HE4
+E4	111	109	8	25	38	24	55	56	HE4A
+E4A	66	65	80	97	110	96			
CHEXA	5	100	9	11	41	39	81	83	HE5
+E5	113	111	10	26	40	25	56	57	HE51
+E51	67	66	82	98	112	97			
CHEXA	6	100	11	13	43	41	83	85	HE6
+E6	115	113	12	27	42	26	57	58	HE61
+E61	68	67	84	99	114	98			
CHEXA	7	100	13	15	45	43	85	87	HE7
+E7	117	115	14	28	44	27	58	59	HE71
+E71	69	68	86	100	116	99			
CHEXA	8	100	15	17	47	45	87	89	HE8
+E8	119	117	16	29	46	28	59	60	HE81
+E81	70	69	88	101	118	100			
CHEXA	9	100	17	19	49	47	89	91	HE9
+E9	121	119	18	30	48	29	60	61	HE91
+E91	71	70	90	102	120	101			
CHEXA	10	100	19	21	51	49	91	93	HE10
+E10	123	121	20	31	50	30	61	62	HE101
+E101	72	71	92	103	122	102			
CPENTA	11	100	73	75	105	145	147	177	PE11
+E11	74	94	104	124	125	135	146	166	PE111
+E111	176								
CHEXA	12	100	75	77	107	105	147	149	HE12
+E12	179	177	76	95	106	94	125	126	HE121
+E121	136	135	148	167	178	166			
CHEXA	13	100	77	79	109	107	149	151	HE13
+E13	181	179	78	96	108	95	126	127	HE131
+E131	137	136	150	168	180	167			
CHEXA	14	100	79	81	111	109	151	153	HE14
+E14	183	181	80	97	110	96	127	128	HE141
+E141	138	137	152	169	182	168			
CHEXA	15	100	81	83	113	111	153	155	HE15
+E15	185	183	82	98	112	97	128	129	HE151
+E151	139	138	154	170	184	169			
CHEXA	16	100	83	85	115	113	155	157	HE16
+E16	187	185	84	99	114	98	129	130	HE161
+E161	140	139	156	171	186	170			
CHEXA	17	100	85	87	117	115	157	159	HE17
+E17	189	187	86	100	116	99	130	131	HE171
+E171	141	140	158	172	188	171			
CHEXA	18	100	87	89	119	117	159	161	HE18
+E18	191	189	88	101	118	100	131	132	HE181
+E181	142	141	160	173	190	172			
CHEXA	19	100	89	91	121	119	161	163	HE19
+E19	193	191	90	102	120	101	132	133	HE191
+E191	143	142	162	174	192	173			
CHEXA	20	100	91	93	123	121	163	165	HE20
+E20	195	193	92	103	122	102	133	134	HE201
+E201	144	143	164	175	194	174			
CPENTA	21	100	145	147	177	217	219	249	PE21
+E21	146	166	176	196	197	207	218	238	PE211
+E211	248								

CHEXA	22	100	147	149	179	177	219	221	EE22
+E22	251	249	148	167	178	166	197	198	EE221
+E221	208	207	220	239	250	238			
CHEXA	23	100	149	151	181	179	221	223	EE23
+E23	253	251	150	168	180	167	198	199	EE231
+E231	209	208	222	240	252	239			
CHEXA	24	100	151	153	183	181	223	225	EE24
+E24	255	253	152	169	182	168	199	200	EE241
+E241	210	209	224	241	254	240			
CHEXA	25	100	153	155	185	183	225	227	EE25
+E25	257	255	154	170	184	169	200	201	EE251
+E251	211	210	226	242	256	241			
CHEXA	26	100	155	157	187	185	227	229	EE26
+E26	259	257	156	171	186	170	201	202	EE261
+E261	212	211	228	243	258	242			
CHEXA	27	100	157	159	189	187	229	231	EE27
+E27	261	259	158	172	188	171	202	203	EE271
+E271	213	212	230	244	260	243			
CHEXA	28	100	159	161	191	189	231	233	EE28
+E28	263	261	160	173	190	172	203	204	EE281
+E281	214	213	232	245	262	244			
CHEXA	29	100	161	163	193	191	233	235	EE29
+E29	265	263	162	174	192	173	204	205	EE291
+E291	215	214	234	246	264	245			
CHEXA	30	100	163	165	195	193	235	237	EE30
+E30	267	265	164	175	194	174	205	206	EE301
+E301	216	215	236	247	266	246			
CPENTA	31	100	217	219	249	289	291	321	EE31
+E31	218	238	248	268	269	279	290	310	EE311
+E311	320								
CHEXA	32	100	219	221	251	249	291	293	EE32
+E32	323	321	220	239	250	238	269	270	EE321
+E321	280	279	292	311	322	310			
CHEXA	33	100	221	223	253	251	293	295	EE33
+E33	325	323	222	240	252	239	270	271	EE331
+E331	281	280	294	312	324	311			
CHEXA	34	100	223	225	255	253	295	297	EE34
+E34	327	325	224	241	254	240	271	272	EE341
+E341	282	281	296	313	326	312			
CHEXA	35	100	225	227	257	255	297	299	EE35
+E35	329	327	226	242	256	241	272	273	EE351
+E351	283	282	298	314	328	313			
CHEXA	36	100	227	229	259	257	299	301	EE36
+E36	331	329	228	243	258	242	273	274	EE361
+E361	284	283	300	315	330	314			
CHEXA	37	100	229	231	261	259	301	303	EE37
+E37	333	331	230	244	260	243	274	275	EE371
+E371	285	284	302	316	332	315			
CHEXA	38	100	231	233	263	261	303	305	EE38
+E38	335	333	232	245	262	244	275	276	EE381
+E381	286	285	304	317	334	316			
CHEXA	39	100	233	235	265	263	305	307	EE39
+E39	337	335	234	246	264	245	276	277	EE391
+E391	287	286	306	318	336	317			
CHEXA	40	100	235	237	267	265	307	309	EE40

+E40	339	337	236	247	266	246	277	278	EE401
+E401	288	287	308	319	338	318			
CORD2C	5	0	0.	0.	0.	0.	0.	1.	+C
+C	1.	0.0	0.						
CYJOIN	1		2	THRU	21	53	THRU	62	+BC
+BC	74	THRU	93	125	THRU	134	146	147	+BC1
+BC1	148	THRU	165	197	THRU	206	218	219	+BC2
+BC2	220	THRU	237	269	THRU	278	290	291	+BC3
+BC3	292	THRU	309						
CYJOIN	2		32	THRU	51	63	THRU	72	+EF
+EF	104	THRU	123	135	THRU	144	176	177	+EF1
+EF1	178	THRU	195	207	THRU	216	248	249	+EF2
+EF2	250	THRU	267	279	THRU	288	320	321	+EF3
+EF3	322	THRU	339						
CYSYM	48	ROT							
GRDSET		5				5	456		
GRID	1		0.000	0.000	0.000				
GRID	2		0.138	0.000	0.000				
GRID	3		0.276	0.000	0.000				
GRID	4		0.552	0.000	0.000				
GRID	5		0.828	0.000	0.000				
GRID	6		1.380	0.000	0.000				
GRID	7		1.932	0.000	0.000				
GRID	8		3.036	0.000	0.000				
GRID	9		4.140	0.000	0.000				
GRID	10		5.797	0.000	0.000				
GRID	11		7.454	0.000	0.000				
GRID	12		9.111	0.000	0.000				
GRID	13		10.768	0.000	0.000				
GRID	14		11.320	0.000	0.000				
GRID	15		11.872	0.000	0.000				
GRID	16		12.148	0.000	0.000				
GRID	17		12.424	0.000	0.000				
GRID	18		12.562	0.000	0.000				
GRID	19		12.700	0.000	0.000				
GRID	20		14.2875	0.000	0.000				
GRID	21		15.875	0.000	0.000				
GRID	22		0.276	3.750	0.000				
GRID	23		0.828	3.750	0.000				
GRID	24		1.932	3.750	0.000				
GRID	25		4.140	3.750	0.000				
GRID	26		7.454	3.750	0.000				
GRID	27		10.768	3.750	0.000				
GRID	28		11.872	3.750	0.000				
GRID	29		12.424	3.750	0.000				
GRID	30		12.700	3.750	0.000				
GRID	31		15.875	3.750	0.000				
GRID	32		0.138	7.500	0.000				
GRID	33		0.276	7.500	0.000				
GRID	34		0.552	7.500	0.000				
GRID	35		0.828	7.500	0.000				
GRID	36		1.380	7.500	0.000				
GRID	37		1.932	7.500	0.000				
GRID	38		3.036	7.500	0.000				
GRID	39		4.140	7.500	0.000				

GRID	40	5.797	7.500	0.000
GRID	41	7.454	7.500	0.000
GRID	42	9.111	7.500	0.000
GRID	43	10.768	7.500	0.000
GRID	44	11.320	7.500	0.000
GRID	45	11.872	7.500	0.000
GRID	46	12.148	7.500	0.000
GRID	47	12.424	7.500	0.000
GRID	48	12.562	7.500	0.000
GRID	49	12.700	7.500	0.000
GRID	50	14.2875	7.500	0.000
GRID	51	15.875	7.500	0.000
GRID	52	0.000	0.000	0.035
GRID	53	0.276	0.000	0.035
GRID	54	0.828	0.000	0.035
GRID	55	1.932	0.000	0.035
GRID	56	4.140	0.000	0.035
GRID	57	7.454	0.000	0.035
GRID	58	10.768	0.000	0.035
GRID	59	11.872	0.000	0.035
GRID	60	12.424	0.000	0.035
GRID	61	12.700	0.000	0.035
GRID	62	15.875	0.000	0.035
GRID	63	0.276	7.500	0.035
GRID	64	0.828	7.500	0.035
GRID	65	1.932	7.500	0.035
GRID	66	4.140	7.500	0.035
GRID	67	7.454	7.500	0.035
GRID	68	10.768	7.500	0.035
GRID	69	11.872	7.500	0.035
GRID	70	12.424	7.500	0.035
GRID	71	12.700	7.500	0.035
GRID	72	15.875	7.500	0.035
GRID	73	0.000	0.000	0.070
GRID	74	0.138	0.000	0.070
GRID	75	0.276	0.000	0.070
GRID	76	0.552	0.000	0.070
GRID	77	0.828	0.000	0.070
GRID	78	1.380	0.000	0.070
GRID	79	1.932	0.000	0.070
GRID	80	3.036	0.000	0.070
GRID	81	4.140	0.000	0.070
GRID	82	5.797	0.000	0.070
GRID	83	7.454	0.000	0.070
GRID	84	9.111	0.000	0.070
GRID	85	10.768	0.000	0.070
GRID	86	11.320	0.000	0.070
GRID	87	11.872	0.000	0.070
GRID	88	12.148	0.000	0.070
GRID	89	12.424	0.000	0.070
GRID	90	12.562	0.000	0.070
GRID	91	12.700	0.000	0.070
GRID	92	14.2875	0.000	0.070
GRID	93	15.875	0.000	0.070
GRID	94	0.276	3.750	0.070

GRID	95	0.828	3.750	0.070
GRID	96	1.932	3.750	0.070
GRID	97	4.140	3.750	0.070
GRID	98	7.454	3.750	0.070
GRID	99	10.768	3.750	0.070
GRID	100	11.872	3.750	0.070
GRID	101	12.424	3.750	0.070
GRID	102	12.700	3.750	0.070
GRID	103	15.875	3.750	0.070
GRID	104	0.138	7.500	0.070
GRID	105	0.276	7.500	0.070
GRID	106	0.552	7.500	0.070
GRID	107	0.828	7.500	0.070
GRID	108	1.380	7.500	0.070
GRID	109	1.932	7.500	0.070
GRID	110	3.036	7.500	0.070
GRID	111	4.140	7.500	0.070
GRID	112	5.797	7.500	0.070
GRID	113	7.454	7.500	0.070
GRID	114	9.111	7.500	0.070
GRID	115	10.768	7.500	0.070
GRID	116	11.320	7.500	0.070
GRID	117	11.872	7.500	0.070
GRID	118	12.148	7.500	0.070
GRID	119	12.424	7.500	0.070
GRID	120	12.562	7.500	0.070
GRID	121	12.700	7.500	0.070
GRID	122	14.2875	7.500	0.070
GRID	123	15.875	7.500	0.070
GRID	124	0.000	0.000	0.211
GRID	125	0.276	0.000	0.211
GRID	126	0.828	0.000	0.211
GRID	127	1.932	0.000	0.211
GRID	128	4.140	0.000	0.211
GRID	129	7.454	0.000	0.211
GRID	130	10.768	0.000	0.211
GRID	131	11.872	0.000	0.211
GRID	132	12.424	0.000	0.211
GRID	133	12.700	0.000	0.211
GRID	134	15.875	0.000	0.211
GRID	135	0.276	7.500	0.211
GRID	136	0.828	7.500	0.211
GRID	137	1.932	7.500	0.211
GRID	138	4.140	7.500	0.211
GRID	139	7.454	7.500	0.211
GRID	140	10.768	7.500	0.211
GRID	141	11.872	7.500	0.211
GRID	142	12.424	7.500	0.211
GRID	143	12.700	7.500	0.211
GRID	144	15.875	7.500	0.211
GRID	145	0.000	0.000	0.352
GRID	146	0.138	0.000	0.352
GRID	147	0.276	0.000	0.352
GRID	148	0.552	0.000	0.352
GRID	149	0.828	0.000	0.352

GRID	150	1.380	0.000	0.352
GRID	151	1.932	0.000	0.352
GRID	152	3.036	0.000	0.352
GRID	153	4.140	0.000	0.352
GRID	154	5.797	0.000	0.352
GRID	155	7.454	0.000	0.352
GRID	156	9.111	0.000	0.352
GRID	157	10.768	0.000	0.352
GRID	158	11.320	0.000	0.352
GRID	159	11.872	0.000	0.352
GRID	160	12.148	0.000	0.352
GRID	161	12.424	0.000	0.352
GRID	162	12.562	0.000	0.352
GRID	163	12.700	0.000	0.352
GRID	164	14.2875	0.000	0.352
GRID	165	15.875	0.000	0.352
GRID	166	0.276	3.750	0.352
GRID	167	0.828	3.750	0.352
GRID	168	1.932	3.750	0.352
GRID	169	4.140	3.750	0.352
GRID	170	7.454	3.750	0.352
GRID	171	10.768	3.750	0.352
GRID	172	11.872	3.750	0.352
GRID	173	12.424	3.750	0.352
GRID	174	12.700	3.750	0.352
GRID	175	15.875	3.750	0.352
GRID	176	0.138	7.500	0.352
GRID	177	0.276	7.500	0.352
GRID	178	0.552	7.500	0.352
GRID	179	0.828	7.500	0.352
GRID	180	1.380	7.500	0.352
GRID	181	1.932	7.500	0.352
GRID	182	3.036	7.500	0.352
GRID	183	4.140	7.500	0.352
GRID	184	5.797	7.500	0.352
GRID	185	7.454	7.500	0.352
GRID	186	9.111	7.500	0.352
GRID	187	10.768	7.500	0.352
GRID	188	11.320	7.500	0.352
GRID	189	11.872	7.500	0.352
GRID	190	12.148	7.500	0.352
GRID	191	12.424	7.500	0.352
GRID	192	12.562	7.500	0.352
GRID	193	12.700	7.500	0.352
GRID	194	14.2875	7.500	0.352
GRID	195	15.875	7.500	0.352
GRID	196	0.000	0.000	0.801
GRID	197	0.276	0.000	0.801
GRID	198	0.828	0.000	0.801
GRID	199	1.932	0.000	0.801
GRID	200	4.140	0.000	0.801
GRID	201	7.454	0.000	0.801
GRID	202	10.768	0.000	0.801
GRID	203	11.872	0.000	0.801
GRID	204	12.424	0.000	0.801

GRID	205	12.700	0.000	0.801
GRID	206	15.875	0.000	0.801
GRID	207	0.276	7.500	0.801
GRID	208	0.828	7.500	0.801
GRID	209	1.932	7.500	0.801
GRID	210	4.140	7.500	0.801
GRID	211	7.454	7.500	0.801
GRID	212	10.768	7.500	0.801
GRID	213	11.872	7.500	0.801
GRID	214	12.424	7.500	0.801
GRID	215	12.700	7.500	0.801
GRID	216	15.875	7.500	0.801
GRID	217	0.000	0.000	1.250
GRID	218	0.138	0.000	1.250
GRID	219	0.276	0.000	1.250
GRID	220	0.552	0.000	1.250
GRID	221	0.828	0.000	1.250
GRID	222	1.380	0.000	1.250
GRID	223	1.932	0.000	1.250
GRID	224	3.036	0.000	1.250
GRID	225	4.140	0.000	1.250
GRID	226	5.797	0.000	1.250
GRID	227	7.454	0.000	1.250
GRID	228	9.111	0.000	1.250
GRID	229	10.768	0.000	1.250
GRID	230	11.320	0.000	1.250
GRID	231	11.872	0.000	1.250
GRID	232	12.148	0.000	1.250
GRID	233	12.424	0.000	1.250
GRID	234	12.562	0.000	1.250
GRID	235	12.700	0.000	1.250
GRID	236	14.2875	0.000	1.250
GRID	237	15.875	0.000	1.250
GRID	238	0.276	3.750	1.250
GRID	239	0.828	3.750	1.250
GRID	240	1.932	3.750	1.250
GRID	241	4.140	3.750	1.250
GRID	242	7.454	3.750	1.250
GRID	243	10.768	3.750	1.250
GRID	244	11.872	3.750	1.250
GRID	245	12.424	3.750	1.250
GRID	246	12.700	3.750	1.250
GRID	247	15.875	3.750	1.250
GRID	248	0.138	7.500	1.250
GRID	249	0.276	7.500	1.250
GRID	250	0.552	7.500	1.250
GRID	251	0.828	7.500	1.250
GRID	252	1.380	7.500	1.250
GRID	253	1.932	7.500	1.250
GRID	254	3.036	7.500	1.250
GRID	255	4.140	7.500	1.250
GRID	256	5.797	7.500	1.250
GRID	257	7.454	7.500	1.250
GRID	258	9.111	7.500	1.250
GRID	259	10.768	7.500	1.250

GRID	260	11.320	7.500	1.250
GRID	261	11.872	7.500	1.250
GRID	262	12.148	7.500	1.250
GRID	263	12.424	7.500	1.250
GRID	264	12.562	7.500	1.250
GRID	265	12.700	7.500	1.250
GRID	266	14.2875	7.500	1.250
GRID	267	15.875	7.500	1.250
GRID	268	0.000	0.000	1.875
GRID	269	0.276	0.000	1.875
GRID	270	0.828	0.000	1.875
GRID	271	1.932	0.000	1.875
GRID	272	4.140	0.000	1.875
GRID	273	7.454	0.000	1.875
GRID	274	10.768	0.000	1.875
GRID	275	11.872	0.000	1.875
GRID	276	12.424	0.000	1.875
GRID	277	12.700	0.000	1.875
GRID	278	15.875	0.000	1.875
GRID	279	0.276	7.500	1.875
GRID	280	0.828	7.500	1.875
GRID	281	1.932	7.500	1.875
GRID	282	4.140	7.500	1.875
GRID	283	7.454	7.500	1.875
GRID	284	10.768	7.500	1.875
GRID	285	11.872	7.500	1.875
GRID	286	12.424	7.500	1.875
GRID	287	12.700	7.500	1.875
GRID	288	15.875	7.500	1.875
GRID	289	0.000	0.000	2.500
GRID	290	0.138	0.000	2.500
GRID	291	0.276	0.000	2.500
GRID	292	0.552	0.000	2.500
GRID	293	0.828	0.000	2.500
GRID	294	1.380	0.000	2.500
GRID	295	1.932	0.000	2.500
GRID	296	3.036	0.000	2.500
GRID	297	4.140	0.000	2.500
GRID	298	5.797	0.000	2.500
GRID	299	7.454	0.000	2.500
GRID	300	9.111	0.000	2.500
GRID	301	10.768	0.000	2.500
GRID	302	11.320	0.000	2.500
GRID	303	11.872	0.000	2.500
GRID	304	12.148	0.000	2.500
GRID	305	12.424	0.000	2.500
GRID	306	12.562	0.000	2.500
GRID	307	12.700	0.000	2.500
GRID	308	14.2875	0.000	2.500
GRID	309	15.875	0.000	2.500
GRID	310	0.276	3.750	2.500
GRID	311	0.828	3.750	2.500
GRID	312	1.932	3.750	2.500
GRID	313	4.140	3.750	2.500
GRID	314	7.454	3.750	2.500

GRID	315		10.768	3.750	2.500				
GRID	316		11.872	3.750	2.500				
GRID	317		12.424	3.750	2.500				
GRID	318		12.700	3.750	2.500				
GRID	319		15.875	3.750	2.500				
GRID	320		0.138	7.500	2.500				
GRID	321		0.276	7.500	2.500				
GRID	322		0.552	7.500	2.500				
GRID	323		0.828	7.500	2.500				
GRID	324		1.380	7.500	2.500				
GRID	325		1.932	7.500	2.500				
GRID	326		3.036	7.500	2.500				
GRID	327		4.140	7.500	2.500				
GRID	328		5.797	7.500	2.500				
GRID	329		7.454	7.500	2.500				
GRID	330		9.111	7.500	2.500				
GRID	331		10.768	7.500	2.500				
GRID	332		11.320	7.500	2.500				
GRID	333		11.872	7.500	2.500				
GRID	334		12.148	7.500	2.500				
GRID	335		12.424	7.500	2.500				
GRID	336		12.562	7.500	2.500				
GRID	337		12.700	7.500	2.500				
GRID	338		14.2875	7.500	2.500				
GRID	339		15.875	7.500	2.500				
PSOLID	100	300	5		0				
MAT1	300	320.+9		0.22					
TEMPD,2,70.									
PARAM	EST	1							
LOADCYH	10	1.0	0		1.0	20			
CYAX	1	52	73	124	145	196	217	268	+CY
+CY	289								
PLOAD4	20	31	15.14310				289		
PLOAD4	20	32	15.14310				291	323	
PLOAD4	20	33	15.14310				293	325	
PLOAD4	20	34	15.14310				295	327	
PLOAD4	20	35	15.14310				297	329	
PLOAD4	20	36	15.14310				299	331	
PLOAD4	20	37	15.14310				301	333	
PLOAD4	20	38	15.14310				303	335	
PLOAD4	20	39	15.14310				305	337	
PLOAD4	20	40	15.14310				307	339	
SPC1	1	3	19	30	49				
ENDDATA									
EOF									
FEND=UX									
mscnast		in=ex5375							

CARES TEMPLAT INPUT FILE

*
* RELIABILITY PREDICTION FOR BRITTLE MATERIAL STRUCTURES *
* --- FAST FRACTURE STATISTICS --- *
* *

MASTER CONTROL INPUT

TITLE : PROBLEM TITLE (ECHOED IN CARES OUTPUT)

EXAMPLE PROBLEM 5: SHEAR-SENSITIVE CALCULATION OF CRACK DENSITY COEFF.

NE : CONTROL INDEX FOR FINITE ELEMENT POSTPROCESSING

(DEFAULT: NE = 0)
1 0 : EXPERIMENTAL DATA ANALYSIS ONLY

1 : MSC/NASTRAN ANALYSIS
2 : ANSYS ANALYSIS

NMATS : NO. OF MATERIALS FOR SURFACE FLAW ANALYSIS

(NMATS+NMATV < 101)
01 (DEFAULT: NMATS = 0)

NMATV : NO. OF MATERIALS FOR VOLUME FLAW ANALYSIS

(NMATS+NMATV < 101)
00 (DEFAULT: NMATV = 0)

IPRINT : CONTROL INDEX FOR STRESS OUTPUT

(DEFAULT: IPRINT = 0)
1 0 : DO NOT PRINT ELEMENT STRESSES AND/OR FRACTURE DATA

1 : PRINT ELEMENT STRESSES AND/OR FRACTURE DATA

LONL : CONTROL INDEX FOR LINEAR OR QUADRATIC ELEMENTS

(DEFAULT: LONL = 0)
1 0 : LINEAR

1 : QUADRATIC (MIDSIDE NODES REQUIRED)

NGP : NO. OF GAUSSIAN QUADRATURE POINTS (15 OR 30)

(DEFAULT: NGP = 15)
15

NS : NO. OF SEGMENTS IN CYCLIC SYMMETRY PROBLEM

(DEFAULT: NS = 1)
048

\$ENDX : END OF MASTER CONTROL INPUT

MATERIAL CONTROL INPUT

TITLE : MATERIAL TITLE (ECHOED IN CARES OUTPUT)

ALUMINA (ALSIMIG 614)

MATID : MATERIAL IDENTIFICATION NO. FROM THE FINITE ELEMENT

MATERIAL PROPERTY CARD (IF POSTPROCESSING IS NOT
0000300 BEING PERFORMED THIS ENTRY SHOULD BE SOME UNIQUE NO.)

(NO DEFAULT)

ID1 : CONTROL INDEX FOR EXPERIMENTAL DATA

(NO DEFAULT)
3

1 : UNIFORM UNIAXIAL TENSILE SPECIMEN TEST DATA
2 : FOUR-POINT BEND TEST DATA
3 : DIRECT INPUT OF THE WEIBULL PARAMETERS, M AND SP
(SHAPE PARAMETER AND SCALE PARAMETER)
4 : CENSORED DATA FOR SUSPENDED ITEM ANALYSIS OF
UNIFORM UNIAXIAL TENSILE SPECIMEN TEST DATA
5 : CENSORED DATA FOR SUSPENDED ITEM ANALYSIS OF
FOUR-POINT BEND TEST DATA

ID4 : CONTROL INDEX FOR VOLUME OR SURFACE FLAW ANALYSIS

(NO DEFAULT)
2

1 : VOLUME
2 : SURFACE

ID2S : CONTROL INDEX FOR SURFACE FRACTURE CRITERION

(NO DEFAULT)
5

1 : NORMAL STRESS FRACTURE CRITERION
(SHEAR-INSENSITIVE CRACK)
3 : COPLANAR STRAIN ENERGY RELEASE RATE CRITERION
(G SUB T)
4 : WEIBULL PIA MODEL
5 : SHETTY'S SEMI-EMPIRICAL CRITERION

ID3S : CONTROL INDEX FOR SHAPE OF SURFACE CRACKS

(NO DEFAULT)
1

1 : GRIFFITH CRACK
(ASSOCIATED WITH STRAIN ENERGY RELEASE RATE CRIT.)
(ASSOCIATED WITH SHETTY'S SEMI-EMPIRICAL CRITERION)
3 : GRIFFITH NOTCH
(ASSOCIATED WITH STRAIN ENERGY RELEASE RATE CRIT.)
(ASSOCIATED WITH SHETTY'S SEMI-EMPIRICAL CRITERION)
4 : SEMICIRCULAR CRACK
(ASSOCIATED WITH SHETTY'S SEMI-EMPIRICAL CRITERION)

IKBAT : CONTROL INDEX FOR METHOD OF CALCULATING BATDORF CRACK

DENSITY COEFFICIENT (K SUB B) FROM TEST DATA
1 (DEFAULT: IKBAT = 0)

0 : SHEAR-INSENSITIVE METHOD (MODE I FRACTURE ASSUMED)
1 : SHEAR-SENSITIVE METHOD (FRACTURE ASSUMED TO OCCUR
ACCORDING TO THE FRACTURE CRITERION AND CRACK SHAPE
SELECTED BY THE ID2 AND ID3 INDICES)

PR : POISSON'S RATIO

(DEFAULT: PR = 0.25)
00000.2200

C : CONSTANT FOR SHETTY'S SEMI-EMPIRICAL MIXED-MODE FRACTURE

CRITERION $(K_I/K_{Ic}) + (K_{II}/(C \cdot K_{Ic}))^{**2} = 1$
00000.8165 OBSERVED VALUES RANGE FROM 0.8 TO 2. (REF. D.K. SHETTY)

NOTE: AS C APPROACHES INFINITY, PREDICTED FAILURE
PROBABILITIES APPROACH NORMAL STRESS CRITERION VALUES
(DEFAULT C = 1.0)

\$ENDM : END OF TEMPERATURE INDEPENDENT MATERIAL CONTROL INPUT

TEMPERATURE DEPENDENT MATERIAL CONTROL INPUT DATA
FOR THE ABOVE MATERIAL

!!
PLEASE NOTE THE FOLLOWING:
1. TEMPERATURE DEPENDENT DATA SETS MUST BE ARRANGED IN ASCENDING ORDER
ACCORDING TO TEMPERATURE.
2. MAXIMUM NUMBER OF TEMPERATURE SETS IS 20.
!!

TDEG : TEMPERATURE OF THIS SET

00070.0000

NOTE: SCALE PARAMETER UNITS ARE MPA(MM)**2/M RATHER THAN MPA(M)**2/M
BECAUSE NASTRAN INPUT WAS IN MILLIMETERS
 $242 \text{ MPA (M)**(2/M)} = 432.3 \text{ MPA (MM)**(2/M)}$

PARAM : WEIBULL MODULUS (SHAPE PARAMETER) AND SCALE PARAMETER
-WEIBULL MODULUS--SCALE PARAMETER-
0.238000E+02 0.432430E+03

END OF DATA FOR THE ABOVE TEMPERATURE

\$ENDT : END OF DATA FOR THE ABOVE MATERIAL

```
*****
*
*          ECHO OF FINITE ELEMENT ANALYSIS DATA          *
*          PROCESSED BY CARES                             *
*
*****
```

***** RESULTS FROM SEARCH OF MSC/NASTRAN BULK DATA *****

40 = TOTAL NUMBER OF SOLID ELEMENTS FOUND (NE)

36 = NUMBER OF HEXA ELEMENTS (NH)

4 = NUMBER OF PENTA ELEMENTS (NP)

0 = NUMBER OF TRIAX6 AXISYMMETRIC ELEMENTS (NA)

10 = TOTAL NUMBER OF SHELL ELEMENTS (NES)

9 = NUMBER OF QUAD8 SHELL ELEMENTS (NSQ)

1 = NUMBER OF TRIA6 SHELL ELEMENTS (NST)

***** MSC/NASTRAN STRESS ANALYSIS OUTPUT *****

\$TITLE = STRESS ANALYSIS OF SHETTY'S SIMPLY SUPPORTED DISK
 \$SUBTITLE= UNIFORM PRESSURE LOAD --SUPPORT RADIUS=12.7MM

--- PRINCIPAL STRESSES AT THE CENTER OF EACH SUBELEMENT OR ELEMENT ---

***** NOTE: TRIA6 ELEMENTS ARE NOT SUBDIVIDED *****

\$ELEMENT TYPE = 64

QUAD8 ELEMENT OUTPUT

ELEMENT	PRC. STRESS I	PRC. STRESS II
42	0.3672278798E+03	0.3610318202E+03
	0.3641486833E+03	0.3641110167E+03
	0.3672278798E+03	0.3610318202E+03
	0.3651638413E+03	0.3608326587E+03
	0.3634200500E+03	0.3625764500E+03
	0.3651638413E+03	0.3608326587E+03
	0.3633043182E+03	0.3604289818E+03
	0.3627290833E+03	0.3610042167E+03
43	0.3633043182E+03	0.3604289818E+03
	0.3631769704E+03	0.3606422796E+03
	0.3624729667E+03	0.3613462834E+03
	0.3631769704E+03	0.3606422796E+03
	0.3609869465E+03	0.3569476035E+03
	0.3605585000E+03	0.3573760500E+03
	0.3609869465E+03	0.3569476035E+03
	0.3589725747E+03	0.3530772753E+03
44	0.3586440333E+03	0.3534058166E+03
	0.3589725747E+03	0.3530772753E+03
	0.3562778044E+03	0.3489429790E+03
	0.3561092334E+03	0.3491115501E+03
	0.3562778044E+03	0.3489429790E+03
	0.3489510096E+03	0.3349993404E+03
	0.3489059000E+03	0.3350444500E+03
	0.3489510096E+03	0.3349993404E+03
45	0.3417139087E+03	0.3209660079E+03
	0.3417025666E+03	0.3209773499E+03
	0.3417139087E+03	0.3209660079E+03
	0.3310770582E+03	0.3005484921E+03
	0.3310744168E+03	0.3005511335E+03
	0.3310770582E+03	0.3005484921E+03
	0.3112072779E+03	0.2621505721E+03
	0.3112072500E+03	0.2621506000E+03
46	0.3112072779E+03	0.2621505721E+03
	0.2913407356E+03	0.2237494141E+03
	0.2913400832E+03	0.2237500665E+03
	0.2913407356E+03	0.2237494141E+03
	0.2668952672E+03	0.1759283899E+03
	0.2668948502E+03	0.1759288070E+03
	0.2668952672E+03	0.1759283899E+03
	0.2365697020E+03	0.1179098680E+03
	0.2365695500E+03	0.1179100200E+03
	0.2365697020E+03	0.1179098680E+03
	0.2062442871E+03	0.5989119579E+02
	0.2062442498E+03	0.5989123304E+02
	0.2062442871E+03	0.5989119579E+02

47	0.1838248009E+03	0.1856336428E+02
	0.1838247667E+03	0.1856339842E+02
	0.1838248009E+03	0.1856336428E+02
	0.1730131005E+03	0.5178145436E+00
	0.1730131000E+03	0.5178150000E+00
	0.1730131005E+03	0.5178145436E+00
	0.1622014516E+03	-0.1752778674E+02
	0.1622014333E+03	-0.1752776842E+02
	0.1622014516E+03	-0.1752778674E+02
48	0.1571244460E+03	-0.1760539838E+02
	0.1571244000E+03	-0.1760535239E+02
	0.1571244460E+03	-0.1760539838E+02
	0.1488482524E+03	-0.3941114786E+02
	0.1488482000E+03	-0.3941109550E+02
	0.1488482524E+03	-0.3941114786E+02
	0.1405720588E+03	-0.6121689741E+02
	0.1405720000E+03	-0.6121683861E+02
	0.1405720588E+03	-0.6121689741E+02
49	0.1439027793E+03	-0.3439627546E+02
	0.1439026868E+03	-0.3439618295E+02
	0.1439027793E+03	-0.3439627546E+02
	0.1247931436E+03	-0.1116543936E+03
	0.1247930600E+03	-0.1116543100E+03
	0.1247931436E+03	-0.1116543936E+03
	0.1056835124E+03	-0.1889125162E+03
	0.1056834332E+03	-0.1889124371E+03
	0.1056835124E+03	-0.1889125162E+03
50	0.1044675918E+03	-0.1253572174E+03
	0.1044675916E+03	-0.1253572172E+03
	0.1044675918E+03	-0.1253572174E+03
	0.1167596800E+03	-0.1534305503E+02
	0.1167596750E+03	-0.1534305000E+02
	0.1167596800E+03	-0.1534305503E+02
	0.1290518556E+03	0.9467102001E+02
	0.1290517584E+03	0.9467111722E+02
	0.1290518556E+03	0.9467102001E+02

§ELEMENT TYPE = 75

TRIA6 ELEMENT OUTPUT

ELEMENT	PRC. STRESS I	PRC. STRESS II
41	0.3641879000E+03	0.3635435000E+03

--- CROSS REFERENCE TABLE FOR SHELL ELEMENTS ---

SHELL ELT. NO.	SOLID ELT. NO.
42	2
43	3
44	4
45	5
46	6
47	7
48	8
49	9
50	10
41	1

--- CROSS REFERENCE TABLE FOR SOLID ELEMENTS ---

SOLID ELT. NO.	SHELL ELT. NOS.
2	42
3	43
4	44
5	45
6	46
7	47
8	48
9	49
10	50
1	41

--- VOLUME AND TEMPERATURE OF EACH SOLID ELEMENT ---

ELEMENT NO.	VOLUME	AVE. TEMP.
2	0.2784E-02	0.7000E+02
3	0.1392E-01	0.7000E+02
4	0.6125E-01	0.7000E+02
5	0.1755E+00	0.7000E+02
6	0.2759E+00	0.7000E+02
7	0.1142E+00	0.7000E+02
8	0.6127E-01	0.7000E+02
9	0.3168E-01	0.7000E+02
10	0.4145E+00	0.7000E+02
12	0.1122E-01	0.7000E+02
13	0.5608E-01	0.7000E+02
14	0.2467E+00	0.7000E+02
15	0.7071E+00	0.7000E+02
16	0.1111E+01	0.7000E+02
17	0.4600E+00	0.7000E+02
18	0.2468E+00	0.7000E+02
19	0.1276E+00	0.7000E+02
20	0.1670E+01	0.7000E+02
22	0.3572E-01	0.7000E+02
23	0.1786E+00	0.7000E+02
24	0.7857E+00	0.7000E+02
25	0.2252E+01	0.7000E+02
26	0.3539E+01	0.7000E+02
27	0.1465E+01	0.7000E+02
28	0.7860E+00	0.7000E+02
29	0.4064E+00	0.7000E+02
30	0.5317E+01	0.7000E+02
32	0.4971E-01	0.7000E+02
33	0.2486E+00	0.7000E+02
34	0.1094E+01	0.7000E+02
35	0.3134E+01	0.7000E+02
36	0.4926E+01	0.7000E+02
37	0.2039E+01	0.7000E+02
38	0.1094E+01	0.7000E+02
39	0.5657E+00	0.7000E+02
40	0.7401E+01	0.7000E+02
1	0.3480E-03	0.7000E+02
11	0.1402E-02	0.7000E+02
21	0.4464E-02	0.7000E+02
31	0.6214E-02	0.7000E+02

--- AREA AND TEMPERATURE OF EACH SHELL ELEMENT ---

ELEMENT NO.	AREA	AVE. TEMP.
42	0.3989E-01	0.7000E+02
43	0.1994E+00	0.7000E+02
44	0.8775E+00	0.7000E+02
45	0.2515E+01	0.7000E+02
46	0.3952E+01	0.7000E+02
47	0.1636E+01	0.7000E+02
48	0.8778E+00	0.7000E+02
49	0.4538E+00	0.7000E+02
50	0.5938E+01	0.7000E+02
41	0.4986E-02	0.7000E+02

```

*****
*                                     *
*           ECHO OF MATERIAL CONTROL INPUT           *
*                                     *
*****

```

TITLE = ALUMINA (ALSIMIG 614)

300 = MATERIAL IDENTIFICATION NUMBER (MATID)

2 = CONTROL INDEX FOR VOLUME OR SURFACE FLAW ANALYSIS (ID4)
 1 : VOLUME
 2 : SURFACE

3 = CONTROL INDEX FOR EXPERIMENTAL DATA (ID1)
 1 : UNIFORM UNIAXIAL TENSILE SPECIMEN TEST DATA
 2 : FOUR-POINT BEND TEST DATA
 3 : DIRECT INPUT OF THE WEIBULL PARAMETERS, M AND SP
 (SHAPE PARAMETER AND SCALE PARAMETER)
 4 : CENSORED DATA FOR SUSPENDED ITEM ANALYSIS OF
 UNIFORM UNIAXIAL TENSILE SPECIMEN TEST DATA
 5 : CENSORED DATA FOR SUSPENDED ITEM ANALYSIS OF
 FOUR-POINT BEND TEST DATA

5 = CONTROL INDEX FOR SURFACE FRACTURE CRITERION (ID2S)
 1 : NORMAL STRESS FRACTURE CRITERION
 (SHEAR-INSENSITIVE CRACK)
 3 : COPLANAR STRAIN ENERGY RELEASE RATE CRITERION
 4 : WEIBULL PIA MODEL
 5 : SHETTY'S SEMI-EMPIRICAL CRITERION

1 = CONTROL INDEX FOR SHAPE OF SURFACE CRACKS (ID3S)
 1 : GRIFFITH CRACK
 (ASSOCIATED WITH STRAIN ENERGY RELEASE RATE CRITERION)
 (ASSOCIATED WITH SHETTY'S SEMI-EMPIRICAL CRITERION)
 3 : GRIFFITH NOTCH
 (ASSOCIATED WITH STRAIN ENERGY RELEASE RATE CRITERION)
 (ASSOCIATED WITH SHETTY'S SEMI-EMPIRICAL CRITERION)
 4 : SEMICIRCULAR CRACK
 (ASSOCIATED WITH SHETTY'S SEMI-EMPIRICAL CRITERION)

1 = CONTROL INDEX FOR METHOD OF CALCULATING BATDORF CRACK DENSITY COEFFICIENT
 (K SUB B) FROM TEST DATA (IKBAT)
 0 : SHEAR-INSENSITIVE METHOD (MODE I FRACTURE ASSUMED)
 1 : SHEAR-SENSITIVE METHOD (FRACTURE ASSUMED TO OCCUR
 ACCORDING TO THE FRACTURE CRITERION AND CRACK
 SHAPE SELECTED BY THE ID2 AND ID3 INDICES)

0.8165 = CONSTANT FOR SHETTY'S SEMI-EMPIRICAL FRACTURE CRITERION (C)
 $(K_I/K_{IC}) + ((K_{II} \text{ OR } K_{III}) / (C * K_{IC}))^2 = 1$
 OBSERVED VALUES RANGE FROM .8 TO 2. (REF. D. K. SHETTY)
 NOTE: AS C APPROACHES INFINITY PREDICTED FAILURE
 PROBABILITIES APPROACH NORMAL STRESS CRITERION

0.2200 = POISSON'S RATIO (PR)

```

XXXXXXXXXXXXXXXXXXXXXXXXXXXXXXXXXXXXXXXXXXXXXXXXXXXXXXXXXXXXXXXXXXXX
X
X          SURFACE FLAW PARAMETER ANALYSIS          X
X
XXXXXXXXXXXXXXXXXXXXXXXXXXXXXXXXXXXXXXXXXXXXXXXXXXXXXXXXXXXXXXXXXXXX

```

**** BATDORF MODEL --- CRACK ORIENTATION, CRACK SHAPE, AND FRACTURE CRITERION AREL
 CONSIDERED ****

--- TEMPERATURE DEPENDENT MATERIAL PARAMETERS FOR MATERIAL NUMBER 300

WEIBULL MODULUS (SHAPE PARAMETER), M (DIMENSIONLESS)
 NORMALIZED BATDORF CRACK DENSITY COEFFICIENT, K (DIMENSIONLESS)
 SCALE PARAMETER, SP (UNITS OF STRESS*AREA*(1/M))

TEMPERATURE	M	K	SP
70.0000	0.2380E+02	0.1416E+01	0.4324E+03

FRACTURE CRITERION = $(KI/KIC) + ((KII \text{ OR } KIII)/(C*KIC))^{*2} = 1$ WHERE C = 0.8165E+00
 CRACK SHAPE = GRIFFITH CRACK

```

XXXXXXXXXXXXXXXXXXXXXXXXXXXXXXXXXXXXXXXXXXXXXXXXXXXXXXXXXXXXXXXXXXXX
X
X          SURFACE FLAW RELIABILITY ANALYSIS          X
X
XXXXXXXXXXXXXXXXXXXXXXXXXXXXXXXXXXXXXXXXXXXXXXXXXXXXXXXXXXXXXXXXXXXX

```

NOTE: THE ELEMENT SURVIVAL AND FAILURE PROBABILITIES TAKE INTO ACCOUNT THE NUMBER OF
 SEGMENTS (NS).

--- ELEMENT CALCULATIONS ---

ELEMENT	MATID	SURVIVAL PROB.	FAILURE PROB.	RISK RUP.	INT.	M	K	SP
42	300	0.9590D+00	0.4103D-01	0.2188D-01	0.2380D+02	0.1416D+01	0.4324D+03	
43	300	0.8510D+00	0.1490D+00	0.1686D-01	0.2380D+02	0.1416D+01	0.4324D+03	
44	300	0.7600D+00	0.2400D+00	0.6516D-02	0.2380D+02	0.1416D+01	0.4324D+03	
45	300	0.9477D+00	0.5227D-01	0.4448D-03	0.2380D+02	0.1416D+01	0.4324D+03	
46	300	0.9997D+00	0.2609D-03	0.1375D-05	0.2380D+02	0.1416D+01	0.4324D+03	
47	300	0.1000D+01	0.3844D-07	0.4895D-09	0.2380D+02	0.1416D+01	0.4324D+03	
48	300	0.1000D+01	0.1427D-08	0.3386D-10	0.2380D+02	0.1416D+01	0.4324D+03	
49	300	0.1000D+01	0.2002D-08	0.9192D-10	0.2380D+02	0.1416D+01	0.4324D+03	
50	300	0.1000D+01	0.2438D-09	0.8555D-12	0.2380D+02	0.1416D+01	0.4324D+03	
41	300	0.9944D+00	0.5639D-02	0.2363D-01	0.2380D+02	0.1416D+01	0.4324D+03	

SORTED MAXIMUM RISK OF RUPTURE INTENSITIES AND CORRESPONDING ELEMENT NUMBERS

ELEMENT	RISK RUP. INT.
41	0.2363D-01
42	0.2188D-01
43	0.1686D-01
44	0.6516D-02
45	0.4448D-03
46	0.1375D-05
47	0.4895D-09
49	0.9192D-10
48	0.3386D-10
50	0.8555D-12

FOR F.E. MODEL SURFACE --- PROBABILITY OF FAILURE = 0.4157D+00
PROBABILITY OF SURVIVAL = 0.5843D+00

Subroutine Descriptions

In addition to the main program, the following subroutines appear in the CARES1 or CARES2 listings:

Subroutine ANGLE This subroutine evaluates $\Omega(\Sigma, \sigma_{cr})$ or $\omega(\Sigma, \sigma_{cr})$ for volume and/or surface flow analysis, respectively, when the Batdorf method is selected. ANGLE employs the quadratic solution procedure described in the **Volume Flow Reliability** and **Surface Flow Reliability** sections of this manual. It determines the critical intervals where $\sigma_e \geq \sigma_{cr}$ for various angles of α and values of σ_{cr} about the unit sphere for volume flow analysis. For some specific stress states ($\sigma_2 = \sigma_3$), this evaluation is independent of β . For surface flow analysis these intervals are determined about the unit circle. For volume flow analysis the critical intervals correspond to the β integral in equation (29). For surface flow analysis the critical intervals correspond to the integral in equation (57). Figure 2 shows the fracture criteria and flow geometries for which the coding has been developed. These correspond to the effective stress equations (20), (21), (24), (25), (27), (28), and (42) for volume flow analysis and to equations (53) to (56) for surface flow analysis. The equations listed in tables I to III are used to find when $\sigma_e = \sigma_{cr}$, and the procedure outlined in equations (38) and (39) is used to find the intervals where $\sigma_e \geq \sigma_{cr}$.

Subroutine ANGLE is called from the main program in the double or single Gaussian integration loops for volume and surface flow analysis, respectively. Arguments R2, R3, and R4 correspond to σ_2 , σ_3 , and $(\sigma_2 - \sigma_3)$, divided by σ_1 for the given stress state. Arguments P and Q represent squared trigonometric functions of the angles α or β , whereas argument H represents the values of σ_{cr} at locations of the Gaussian quadrature points. These arguments are required within ANGLE to calculate intermediate variables a_1 , a_2 , and a_3 that are coefficients in the quadratic equation for $\cos^2\alpha$ or $\cos^2\beta$ listed in tables I to III.

Subroutine ANGLES This subroutine is used with the Batdorf volume flow model to integrate over the surface area of a quadrant of the unit sphere when $\sigma_3 < 0$ or when the Shetty failure criterion is used and $\sigma_{e_{max}} > \sigma_1$. ANGLES determines the intervals where $\sigma_e \geq \sigma_{cr}$ for constant angles of α about the unit sphere and stores the limits of these intervals in the INTVAL array. The critical intervals correspond to the integral of β described in equation (29). The limits of these intervals are determined for each transformed Gaussian value of σ_{cr} and α . Each consecutive pair of integers in the third index of array INTVAL represents an interval where $\sigma_e \geq \sigma_{cr}$ for an angle of α denoted by the second index. The first index corresponds to values of σ_{cr} at locations of the Gaussian quadrature points. The limits of integration stored in INTVAL are

integers representing one-degree increments of angle β counted from $-\pi/2$ to $\pi/2$.

Subroutine BINIO This subroutine pertains to the reading and processing of ANSYS files and is not described herein. Consult reference 31 for further information.

Subroutine CONFLC This subroutine contains the factors for obtaining 90-percent upper and lower confidence bounds of the MLE of σ_θ . These factors have been taken from reference 38. They are obtained from a Monte Carlo simulation by using maximum likelihood analysis and uncensored data. The confidence bound calculations are performed in subroutine MATL.

Subroutine CONFLM This subroutine contains the factors for obtaining 90-percent upper and lower confidence bounds of the MLE of m . These factors have been taken from reference 38. They are obtained from a Monte Carlo simulation by using maximum likelihood analysis and uncensored data. The confidence bound calculations are performed in subroutine MATL.

Subroutine CRACKS This subroutine is called from MATBAT and serves as an interface with the SORMAL, SNGLES, SVALP3, and FINDP subroutines for the calculation of the shear-sensitive (IKBAT = 1) normalized Batdorf surface crack density coefficient \bar{k}_{BS} for the Shetty criterion when $\sigma_{e_{max}} > \sigma_1$.

Subroutine CRACKV This subroutine is called from MATBAT and serves as an interface with the NORMAL, ANGLES and EVALP3 subroutines for the calculation of the shear-sensitive (IKBAT = 1) normalized Batdorf volume crack density coefficient \bar{k}_{BV} for the Shetty criterion when $\sigma_{e_{max}} > \sigma_1$.

Subroutine CRACRS This subroutine is called from the main program and serves as an interface with the SORMAL, SNGLES, SVALP3, and FINDP subroutines for the calculation of element or subelement reliability for surface flaws with the Shetty criterion when $\sigma_{e_{max}} > \sigma_1$, or when $\sigma_2 < 0$ for all shear sensitive fracture criteria.

Subroutine CRACRV This subroutine is called from the main program and serves as an interface with the NORMAL, ANGLES, and EVALP3 subroutines for the calculation of element or subelement reliability for volume flaws with the Shetty criterion when $\sigma_{e_{max}} > \sigma_1$, or when $\sigma_3 < 0$ for all shear sensitive fracture criteria.

Subroutine EANSYS This subroutine pertains to the reading and processing of ANSYS files and is not described herein. Consult reference 31 for further information.

Subroutine EIGEN This subroutine calculates principal stresses from any two- or three-dimensional stress state by using the trigonometric solution method for obtaining the roots of a cubic polynomial. It is used in the CARES2 program for HEXA and QUAD8 elements where principal stresses are calculated at the centroids of subelements by interpolating the normal and shear stresses from the corner nodes. It is also used in CARES1 and CARES2 for calculating the centroidal principal stresses for the TRIAX6 axisymmetric element.

Subroutine ELEM The flowchart for subroutine ELEM is contained in figure 4. This subroutine is the interface between the MSC/NASTRAN output and the CARES reliability analysis. The three main functions of ELEM are to determine (1) element stresses, (2) element temperatures, and (3) element volumes and/or areas as appropriate.

ELEM begins by reading the NASTRAN BULK DATA from a punch file previously prepared by the user in accordance with the instructions of the **Input Information** section of this manual. Since NASTRAN outputs BULK DATA in a left-justified format and FORTRAN expects to read right-justified data, coding was implemented to right justify and place the BULK DATA in a temporary file. Items placed in the temporary file are nodal temperatures (TEMP, TEMP*, and TEMPD), PSOLID, PSHELL, and nodal connectivity card images for HEXA, PENTA, TRIAX6, QUAD8, and TRIA6 isoparametric elements. The BULK DATA in the temporary file are read and the node numbers associated with each element are stored in the MOEL and NOEL arrays for shell and solid elements, respectively. The first index corresponds to the element, and the second index contains the node numbers.

Element temperatures are determined by matching nodal temperatures from the BULK DATA with the element connectivity and computing the average temperature for each element. If QUAD8 or TRIA6 elements are present, then it is assumed that these elements share common nodes with the solid elements. Matching routines have been incorporated into ELEM to print cross-reference tables for the solid and shell elements that share common nodes.

Element stresses are read from the punch file. In CARES1, the element centroidal principal stresses are read. In CARES2, the element corner nodal stresses for HEXA and QUAD8 elements are read and the subelement centroidal principal stresses are calculated by the SHAPE2 and EIGEN subroutines. CARES2 does not discretize PENTA, TRIAX6, or TRIA6 elements into subelements; instead, it reads the element centroidal stresses from the punch file.

The ELEM subroutine reads element volumes and areas from the NASTRAN printout file. See the **Input Information** section of this manual for the commands to have element volumes and areas printed in the MSC/NASTRAN printout file.

Subroutine EVALP3 This subroutine is used with the Batdorf model for volume flaw analysis with the Shetty failure criterion when $\sigma_{e_{max}} > \sigma_1$, or when $\sigma_3 < 0$ for all shear sensitive fracture criteria. It performs the integration

$$\int_0^{\sigma_{e_{max}}} \int_0^{\pi/2} \left(\int_0^{\pi} d\beta \right) \sin \alpha \sigma_{cr}^{m-1} d\alpha d\sigma_{cr} \quad (100)$$

which is used in equations (29) and (40a) to determine elemental probability of failure. Gauss-Legendre quadrature is used for the numerical integrations of $d\alpha$ and $d\sigma_{cr}$. The stored values in the INTVAL array previously calculated in the ANGLES subroutine are used to perform the integration.

Subroutine FINDP This subroutine is used with the Batdorf model for surface flaw analysis with the Shetty failure criterion when $\sigma_{e_{max}} > \sigma_1$, or when $\sigma_2 < 0$ for all shear sensitive fracture criteria. It calculates P_{2S} as defined by equation (57). The interval is determined from transforming values stored in the INTVAL array into real numbers. FINDP is called from the SVALP3 subroutine.

Subroutine GAUSS This subroutine contains roots of the Legendre polynomials and the weight factors for the Gauss quadrature. This numerical integration method calculates element or subelement reliabilities when the Batdorf fracture models are used. It is also employed in the calculation of the Batdorf crack density coefficient, when a closed-form solution is not available. The number of Gauss points (NGP) is specified by the user in the program input. Data are available in GAUSS for NGP = 2, 3, 4, 5, 6, 7, 8, 9, 10, 15, and 30, although only 15 and 30 are recommended. The weights and locations are contained in the W and H arrays, respectively.

Subroutine INTER This subroutine determines the subelement centroidal stresses from the NASTRAN HEXA or QUAD8 element corner nodal stress values. The arrays SX, SY, and SZ contain the three normal stresses, whereas SXY, SYZ, and SZX represent the three shear stresses for each corner node. For the plane stress condition, only the SX, SY, and SXY arrays are used. The subelement centroidal stresses are obtained through linear interpolation by using the interpolation factors determined from the SHAPE2 subroutine. The principal stresses are then determined at the centroid of each subelement by using the EIGEN subroutine to calculate the eigenvalues of the stress tensor at that point. The principal stresses are subsequently reordered by subroutine SORTR so that the largest value is designated as the first principal stress, the second largest value is the second principal stress, and so on for each subelement.

Subroutine LEAST2 This subroutine calculates the Weibull strength parameters \hat{m} and \hat{C} by using the least-squares analysis method for complete or censored samples. The slope m and the intercept ($\ln C$) of the line of best fit are obtained by solving two simultaneous equations (ref. 30). For uncensored data, median rank regression analysis (eq. (64)) is used to calculate the failure probability, P_f . However, in case of censored data, the median rank regression analysis cannot be used directly because of the effect of competing failure modes. Instead, the rank increment technique (eq. (65)) is used to adjust rank values. These adjusted rank values are then used with median rank regression analysis to calculate the failure probability. The LEAST2 subroutine is called from the MATL subroutine.

Subroutine MATBAT This subroutine calculates the surface and/or volume scale parameters, σ_{oS} and σ_{oV} , and the normalized Batdorf crack density coefficients, \bar{k}_{BS} and \bar{k}_{BV} , respectively. For a given material, parameters are found for each temperature level that is input by the user. If m_S and σ_{oS} or m_V and σ_{oV} are directly input, then only \bar{k}_{BS} or \bar{k}_{BV} is calculated, respectively. If experimental fracture stresses are input for either four-point bend or uniaxial tensile specimens, then all required parameters are calculated. The scale parameter for volume flaws is calculated from equation (75), and for surface flaws, equation (90) is used. The scale parameter is determined from the specimen geometry and from the values of m and C estimated in the LEAST2 or MAXL subroutines. The coefficient \bar{k}_{BS} is calculated from equation (94) or (97), and \bar{k}_{BV} is calculated from equation (81) or (87). The ANGLE subroutine is called from MATBAT to evaluate $\omega(\Sigma, \sigma_{cr})/2\pi$ or $\Omega(\Sigma, \sigma_{cr})/4\pi$ for a uniaxial stress state to find \bar{k}_{BS} or \bar{k}_{BV} . If the Shetty criterion is selected by the user with the $IKBAT = 1$ option when $\sigma_{e_{max}} > \sigma_1$, then the CRACKS subroutine finds $\omega(\Sigma, \sigma_{cr})/2\pi$ and the CRACKV subroutine finds $\Omega(\Sigma, \sigma_{cr})/4\pi$ to calculate \bar{k}_{BS} and \bar{k}_{BV} , respectively.

Subroutine MATL This subroutine controls the program logic flow for the determination of the statistical material parameters and other useful statistical quantities as shown in the flowchart of figure 3. Kolmogorov-Smirnov and Anderson-Darling goodness-of-fit tests, Kanofsky-Srinivasan 90-percent confidence bands, Weibull mean, Weibull variance, and 90-percent confidence bounds on the parameters are all calculated in this subroutine. Ancillary subroutines to detect outliers (OUTLIE), to perform least-squares (LEAST2) or maximum likelihood (MAXL) analysis, to calculate Weibull scale parameters and the Batdorf crack density coefficient (MATBAT), and to print out results of the analysis (PRINTP) are called from MATL.

Subroutine MAXL This subroutine determines the MLE's of the Weibull strength parameters m and σ_θ by using the maximum likelihood method for both uncensored and censored data. The logarithm of the likelihood function is differentiated with respect to m and C , and the resulting expressions are set equal to zero (eqs. (62), and (66) to (68)). The Newton-Raphson iterative technique is used to obtain the parameter MLE's by solving these nonlinear equations. The estimate of m for the first iteration is obtained from least-squares analysis via the LEAST2 subroutine. If the convergence criterion is not met after 50 iterations, the maximum likelihood method is terminated, a warning message is printed, and the results from the least-squares analysis are subsequently used in the program. If the fracture data are a complete sample, then the unbiased estimate of the shape parameter is calculated with the factors stored in the UNBIAS subroutine. The unbiased estimate is passed to the MATL subroutine and is later printed out in the PRINTP subroutine. This parameter is not employed in any subsequent analysis or reliability predictions. Reference 30 contains a detailed description of the method of calculation of these statistical quantities. The MAXL subroutine is called from the MATL subroutine.

Subroutine NORMAL This subroutine is called when the Batdorf volume flaw model is used with the Shetty failure criterion and $\sigma_{e_{max}} > \sigma_1$, or when $\sigma_3 < 0$ for all shear sensitive fracture criteria. NORMAL calculates the normalized effective stress about the unit sphere as a function of the angles α and β , and stores these values in the SEANGL array. The effective stress is determined for 1° increments of β and is stored in the second index of the array. The first index denotes angles of α with values corresponding to the transformed Gaussian points. The array values are normalized by the maximum effective stress $\sigma_{e_{max}}$ found for the stress state being evaluated. The effective stress is calculated from equations (20), (21), (24), (25), (27), and (28).

Subroutine OUTLIE In this subroutine, the available specimen fracture stress data at each temperature level are examined for outliers or inconsistent data. At the start of the subroutine, the sample mean and sample standard deviation are calculated. From these values, the normed residual for each specimen is obtained (ref. 34). The normed residuals are normalized deviations of the data about the sample mean. The Weibull distribution is not symmetrical about its mean, and therefore this technique is only approximate. The absolute maximum of the normed residual (MNR) statistic is compared with the critical value (CV) at 1-, 5-, and 10-percent significance levels. If the MNR statistic is smaller than the three critical values, then no outliers are detected. However, if the MNR is larger than at least one of the three critical values, the corresponding

data value with the MNR statistic is detected as an outlier with the appropriate significance level. The outlier test can only flag one point per trial as an outlier. If an outlier is detected at the 10-percent or less significance level, it is removed from the sample and the remaining points are then retested. This process is repeated until the sample is reduced such that no more outliers are detected. Once all such points are detected, each of these potential outliers is retested against the remaining "good" data, and those points that maintain significance levels at or below 10 percent are flagged with the appropriate significance level in the ISKIP array. The results of the outlier test are output in the PRINTP subroutine via the MATL subroutine. A discussion of the equations used with this method is given in reference 30.

Subroutine PRINTA This subroutine echoes the user input or default values from the Master Control Input.

Subroutine PRINTB This subroutine echoes the user input or default values from the Material Control Input.

Subroutine PRINTO This subroutine is called at the end of the main program to print element reliability tables, sorted maximum risk-of-rupture intensity values, and overall component reliability. PRINTO is called for each type of analysis performed, either volume or surface analysis. Thus, PRINTO can only be invoked twice. For each analysis, a summary table is generated listing the elements in the order they were output by MSC/NASTRAN. For volume flaw analysis, the table lists information for the solid elements. For surface flaw analysis, the table lists information for shell elements. Each element is identified by its ID and material number. The table contains the calculated element survival probability, failure probability, risk-of-rupture intensity, and the temperature-dependent interpolated statistical material parameters for m , \bar{k}_B , and σ_o . Following each table is a list of the 15 maximum risk-of-rupture intensity values and corresponding element ID numbers. The overall survival and failure probability for the component is also printed.

Subroutine PRINTP This subroutine prints the values of all of the statistical quantities calculated in MATL, OUTLIE, LEAST2, MAXL, and MATBAT subroutines at each discrete temperature. A detailed description of the information printed can be found in the **CARES Output Information** section of this manual.

Subroutine READER This subroutine pertains to the reading and processing of ANSYS files and is not described herein. Consult reference 31 for further information.

Subroutine READST This subroutine pertains to the reading and processing of ANSYS files and is not described herein. Consult reference 31 for further information.

Subroutine RWSKIP This subroutine pertains to the reading and processing of ANSYS files and is not described herein. Consult reference 31 for further information.

Subroutine SHAPE1 Material statistical fracture parameters (m , \bar{k}_B , and σ_o) are usually known at a number of discrete temperatures. Subroutine SHAPE1 uses one-dimensional Lagrangian interpolating polynomials to calculate these required parameters at the temperature associated with any given element. The degree of the interpolating polynomial is one less than the number of temperatures input for each material. To minimize error, it is recommended that this number be limited to 10 or less (ref. 64), although the CARES program allows up to 20 temperature sets in case severe parameter variations with temperature mandate a large data base.

Subroutine SHAPE2 This subroutine is used to calculate coefficients for the two- and three-dimensional linear interpolation of selected element stress components. Array SHP2 contains the calculated four or eight linear Lagrangian interpolation function shape factors. This array is passed to subroutine INTER, where the four or eight factors are used for the two- or three-dimensional mapping, respectively, of the element stresses. Argument IP represents the number of interpolation points in the normalized interval -1.0 to 1.0 . For 27 subelements in each HEXA element and 9 subelements in the QUAD8 element, IP is set equal to 3 in each direction. Arguments X1, X2, and X3 are the locations of the interpolation points in the normalized interval; they correspond to the locations of subelement centroids in the element natural coordinate system. With 27 or 9 equal subelements, X1, X2, and X3 are taken as $-\frac{2}{3}$, 0 , and $\frac{2}{3}$ in the interval -1.0 to 1.0 . The stress state at a subelement centroid is expressed as a linear combination of the element corner nodal stress values with the values of array SHP2 serving as coefficients.

Subroutine SNGLES This subroutine is used with the Batdorf surface flaw model to integrate over the contour of the unit circle when $\sigma_2 < 0$ for shear sensitive failure criteria or when the Shetty failure criterion is used and $\sigma_{e_{\max}} > \sigma_1$. SNGLES determines the intervals where $\sigma_e \geq \sigma_{cr}$ about the unit circle and stores the limits of these intervals as a function of σ_{cr} in the INTVAL array. The critical intervals correspond to the integral described by equation (57) to determine $\omega(\Sigma, \sigma_{cr})$. The limits of these intervals are determined for each transformed Gaussian value of σ_{cr} . Each consecutive pair of integers in the second index of array INTVAL represents an interval where $\sigma_e \geq \sigma_{cr}$ for a value of σ_{cr} denoted by the first index. The limits of integration stored in INTVAL are integers representing 1° increments of angle counted from $-\pi/2$ to $\pi/2$.

Subroutine SORMAL This subroutine is called when the Batdorf surface flaw model is used with the Shetty failure criterion when $\sigma_{e_{\max}} > \sigma_1$, or when $\sigma_2 < 0$ for all shear sensitive fracture criteria. SORMAL calculates the normalized effective stress about the unit circle as a function of the angle α and stores it in the SEANGL array. The effective stress is determined for one-degree increments of α . The array values are normalized by the maximum effective stress $\sigma_{e_{\max}}$ found for the stress state being evaluated. The effective stress is calculated from equations (53) to (56).

Subroutine SORTI Similar to other sorting routines used in CARES, SORTI is used to sort integers into ascending or descending order depending on the value of IASEND as described in subroutine SORTII. This subroutine is used to sort PSOLID or PSHELL card ID's into an overall ascending order to facilitate matching element ID's with the proper material identification number. ID is the array representing the sorted integers (PSOLID or PSHELL ID's), and INDEX contains the corresponding material identification numbers read from the PSOLID or PSHELL card. NSORT is an integer indicating the number of values to be sorted. This subroutine is called from the ELEM subroutine.

Subroutine SORTII To calculate element temperatures from NASTRAN nodal temperature data, it is computationally advantageous to sort the grid point numbers of the elements into ascending order. Array ID contains the node numbers to be sorted, and argument NSORT represents the number of integers to be sorted. NSORT equals 20 for HEXA, 15 for PENTA, 6 for TRIAX6, 8 for QUAD8, and 6 for TRIA6 finite elements when all midside nodes are present (LONL = 1). When LONL = 0, NSORT equals 8 for HEXA, 6 for PENTA, 3 for TRIAX6, 4 for QUAD8, and 3 for TRIA6. SORTII is called from the ELEM subroutine. The IASEND parameter determines the sorting direction: that is, if IASEND equals 1, integers are placed in ascending order; whereas if IASEND equals 0, integers are placed in a descending order.

Subroutine SORTIR This subroutine sorts element nodes and their corresponding temperatures into ascending order according to node number (IASEND = 1). This facilitates the matching of element nodes with nodal temperatures, and thereby enables the determination of element temperatures within subroutine ELEM. Array ID contains node numbers to be sorted, and parameter NSORT is equal to the total number of nodes. Note that NSORT is not the total number of nodes in the finite element model, but is equal only to the number of nodes with assigned TEMP or TEMP* BULK DATA cards. The RINDEX array contains the temperatures that correspond to the node numbers.

Subroutine SORTR In reliability analysis it is essential that the principal stresses be consistently identified, with σ_1 denoting the maximum value, σ_2 the intermediate stress, and σ_3 the minimum principal stress. Subroutine SORTR orders principal stresses into ascending order (IASEND = 1). NSORT is the count of real numbers to be sorted, which equals three in the case of principal stresses. Array D contains the unsorted and, eventually, the sorted stresses.

Subroutine SORTRA This subroutine sorts the experimental fracture stresses at a given temperature level into ascending order (IASEND = 1) along with the corresponding fracture origins. It is invoked at the beginning of subroutine MAIL. Array D contains the fracture stresses to be sorted, and the parameter NSORT equals the number of fracture stresses. The alphanumeric AINDEX array contains fracture origins (S, V, or U) that correspond in position to the sorted stresses.

Subroutine SORTRI This subroutine sorts the calculated risk-of-rupture intensities with their corresponding element ID's into ascending order (IASEND = 1). It determines the maximum values of risk of rupture intensity and is invoked at the end of the main program. Array D contains risk-of-rupture intensities to be sorted, and the parameter NSORT is equal to the number of elements for which failure probabilities were calculated. The INDEX array contains element ID's that correspond in position to the risk-of-rupture intensities.

Subroutine SVALP3 Subroutine SVALP3 is used with the Batdorf model for surface flaw analysis with the Shetty criterion when $\sigma_{e_{\max}} > \sigma_1$, or when $\sigma_2 < 0$ for all shear sensitive fracture criteria. It performs the integration

$$\int_0^{\sigma_{e_{\max}}} \left(\int_0^{\alpha} d\alpha \right) \sigma_{e,r}^{m-1} d\sigma_{e,r} \quad (101)$$

which is used in equations (57) and (61) to determine the elemental probability of failure. Gauss-Legendre quadrature is used for the numerical integration of $d\sigma_{e,r}$. The stored values in the INTVAL array, which were previously calculated in the SNGLES subroutine, are used to perform the integration. The FINDP subroutine is called from SVALP3 to perform the evaluation of P_{2S} for each transformed Gaussian value of $\sigma_{e,r}$.

Subroutine UNBIAS This subroutine contains unbiasing factors for the Weibull modulus \hat{m} . These factors are a function of sample size and are taken from reference 38. They are obtained from a Monte Carlo simulation of unimodal fracture data by using maximum likelihood analysis. The factors are based on the sample mean. The

unbiased estimate of m is obtained by multiplying the biased estimate of m by the unbiasing factor.

Subroutine WRITER This subroutine pertains to the reading and processing of ANSYS files and is not described herein. Consult reference 31 for further information.

Subroutine WRITSP This subroutine pertains to the reading and processing of ANSYS files and is not described herein. Consult reference 31 for further information.

Subroutine WRITST This subroutine pertains to the reading and processing of ANSYS files and is not described herein. Consult reference 31 for further information.

Appendix A Symbols

A	surface area	k_B	Batdorf crack density coefficient, or flaw distribution parameter
A^2	Anderson-Darling goodness-of-fit test statistic	\bar{k}_B	normalized Batdorf crack density coefficient
a	crack half length; penny-shaped crack radius; radius of semi-circular surface crack	k_w	Weibull crack density coefficient, $(1/\sigma_0)^m$
a_j	coefficients of quadratic equation used for calculating Φ_j where $j = 1, 2, 3$	k_{wp}	polyaxial Weibull crack density coefficient
B	risk of rupture in Weibull's cumulative failure distribution	L	likelihood function
b	the intersection of a line with the ordinate axis	L_1	length between outer loads in four-point bending
C	modified Weibull parameter $C = (1/\sigma_0)^m$	L_2	length between symmetrically applied inner loads in four-point bending
\bar{C}	Shetty's constant in mixed-mode fracture criterion	ℓ, m, n	direction cosines of oblique plane normal in principal stress space for the Cauchy infinitesimal tetrahedron
CV	critical value	ℓn	natural logarithm
c	the contour of a unit radius circle in two-dimensional principal stress space	MOR	modulus of rupture, or extreme fiber fracture stress
D	Kolmogorov-Smirnov goodness-of-fit test statistic defined as D^+ or D^- whichever is largest	MOR_o	characteristic modulus of rupture, or extreme fiber fracture stress at which 63.2 percent of MOR bars will fail
D_j	constants used in calculating P_2 for $j = 1, 2, 3$	m	Weibull modulus, or shape parameter; Batdorf crack density function exponent, or flaw distribution parameter
D^+, D^-	Kolmogorov-Smirnov goodness-of-fit test statistic	N	number of MOR specimens at a given temperature
E	Young's modulus of elasticity	NGP	number of Gauss base points used in numerical integration
$F(x)$	cumulative distribution function of a random variable	$N(\sigma)$	Weibull crack density function, or number of flaws per unit volume or area with strength $\leq \sigma$ in uniaxial stress state
$F(\sigma)$	Weibull cumulative distribution of material strength	$N(\sigma_{cr})$	Batdorf crack density function which is a material property independent of stress state and is the number of cracks per unit volume or area with strength $\leq \sigma_{cr}$
$F_N(x)$	empirical distribution function	n	number of links in a structure
G	strain energy release rate, or crack extension force	\bar{n}	unit vector along oblique plane normal determined by angles α and β in principal stress space
G_C	critical value of strain energy release rate	P	load applied to MOR bar specimen (fig. 14)
G_I	strain energy release rate for crack opening mode crack extension	P_f	cumulative failure probability
G_{II}	strain energy release rate for crack sliding mode crack extension	P_s	cumulative survival probability
G_{III}	strain energy release rate for crack tearing mode crack extension	P_1	probability of existence in incremental volume or area of a crack with strength $\leq \sigma_{cr}$
G_{max}	maximum strain energy release rate	P_2	probability of crack with strength $\leq \sigma_{cr}$ being so oriented that $\sigma_e \geq \sigma_{cr}$
G_T	total strain energy release rate	PIA	principle of independent action model
h	total height of MOR bar with rectangular cross section	r	number of remaining specimens in censored data analysis
i	ranking of ordered fracture data in statistical analysis; any counter	r_i	inside radius
K_I	opening mode stress intensity factor		
K_{IC}	critical opening mode stress intensity factor		
K_{II}	sliding mode stress intensity factor		
K_{III}	tearing mode stress intensity factor		
K_δ	K_{II} or K_{III}		
$K(N)$	Kanofsky-Srinivasan confidence band factors		

r_o	outside radius	$\bar{\sigma}_n$	normal stress averaged about a unit radius sphere or unit radius circle
t	thickness	σ_o	Weibull scale parameter, or Weibull normalizing stress
V	volume	σ_u	Weibull location parameter, or Weibull threshold stress
w	total width of MOR bar with rectangular cross section	$\sigma_1, \sigma_2, \sigma_3$	principal stresses ($\sigma_1 \geq \sigma_2 \geq \sigma_3$)
x	any variable	σ_θ	volume or area characteristic strength, or characteristic modulus of rupture, MOR_o . (This is the stress or extreme fiber stress at which 63.21 percent of the specimens will fail.)
X	ordered statistics	τ	shear stress acting on oblique plane whose normal is determined by angles α and β (figs. 11 and 12).
x, y, z	Cartesian coordinate directions	Φ	defined as $\cos^2 \bar{\beta}$ or $\cos^2 \bar{\alpha}$, depending on stress state, for which $\sigma_e - \sigma_{cr} = 0$
Z_i	predicted failure probability at the fracture strength of the i^{th} specimen	Ω	solid angle in three-dimensional principal stress space for which $\sigma_e \geq \sigma_{cr}$
α	angle between σ_n and the maximum principal stress, σ_1 (figs. 11 and 12); significance level	ω	angle in two-dimensional principal stress space for which $\sigma_e \geq \sigma_{cr}$
$\bar{\alpha}$	defined as root of $\cos^{-1} \Phi$, when $\sigma_1 > \sigma_2 = \sigma_3$ for volume flaws and also for surface flaws when $\sigma_1 > \sigma_2$		
β	angle between σ_n projection and the intermediate principal stress σ_2 in plane perpendicular to σ_1 (fig. 11)		
$\bar{\beta}$	defined as root of $\cos^{-1} \Phi$, when $\sigma_2 \neq \sigma_3$		
Γ	gamma function which is tabulated in mathematical handbooks		
Δ	increment		
ΔP_1	probability of existence in incremental volume or area of a crack with strength between σ_{cr} and $\sigma_{cr} + \Delta\sigma_{cr}$	Subscripts:	
ν	material Poisson's ratio	B	Batdorf
π	3.1416	cr	critical
Π	usual product notation	e	effective
Σ	applied multidimensional stress state; summation notation	f	failure, fracture
σ	applied stress distribution; the traction or stress vector on oblique plane of Cauchy infinitesimal tetrahedron (figs. 11 and 12)	g	gage
σ_{cr}	remote, macroscopic, uniaxial, normal fracture stress of a crack	I	crack opening mode
σ_e	effective stress acting on a crack plane, $\sigma_e = f(\sigma_n, \tau)$	II	crack sliding mode
$\sigma_{e_{\max}}$	maximum effective stress for the particular stress state	III	crack tearing mode
σ_f	extreme fiber fracture stress in MOR bar test	n	normal
σ_n	normal stress acting on oblique plane whose normal is determined by angles α and β (figs. 11 and 12)	p	polyaxial
		s	survival
		S	surface
		V	volume
		w	Weibull
		Superscripts:	
		$\hat{}$	estimated parameter

Appendix B

Glossary of Terms

- A-D Anderson-Darling goodness-of-fit test
- AINDEX See **Subroutine Descriptions** for subroutine SORTRA.
- AMDAHL Mainframe computer manufactured by Amdahl, Inc.
- ANGLE See **Subroutine Descriptions**.
- ANGLES See **Subroutine Descriptions**.
- ANSYS Finite element analysis computer program produced by Swanson Analysis Systems, Inc.
- BULK DATA See BULK DATA DECK.
- BULK DATA DECK Defines the physical problem input to NASTRAN—including the finite element model, constraints, and loading conditions
- C See **Material Control Input**.
- °C Temperature in degrees centigrade
- CARES Ceramics Analysis and Reliability Evaluation of Structures (CARES) computer program for predicting the fast-fracture failure probability of ceramic components
- CARES1 Version of CARES that performs reliability analysis based on element centroidal principal stresses (CARES1 assumes that stress and temperature gradients for each element are negligible)
- CARES2 Version of CARES that takes into account element stress gradients by dividing each HEXA element into 27 subelements and each QUAD8 element into 9 subelements
- CASE CONTROL DECK Provides user control over the NASTRAN program input and output
- CERAM Battelle Memorial Institute's ceramics reliability analysis computer code (see refs. 61 and 63)
- CHEXA Element connectivity card for an isoparametric six-sided solid element
- cm Dimensions in centimeters
- CONFLC See **Subroutine Descriptions**.
- CONFLM See **Subroutine Descriptions**.
- COSMIC Computer Software Management & Information Center (COSMIC)—makes government-developed computer programs available to the public
- CPENTA Element connectivity card for an isoparametric five-sided solid element
- CPU Central processing unit
- CQUAD8 Element connectivity card for a quadrilateral isoparametric shell element
- CRAY X-MP Supercomputer that runs the MSC/NASTRAN computer program at NASA Lewis (manufactured by Cray Research, Inc.)
- CRACKS See **Subroutine Descriptions**.
- CRACKV See **Subroutine Descriptions**.
- CRACRS See **Subroutine Descriptions**.
- CRACRV See **Subroutine Descriptions**.
- CTRIA6 Element connectivity card for an isoparametric, triangular shell element
- CTRIAX6 Element connectivity card for an isoparametric, triangular axisymmetric element
- CYCLIC STATICS MSC/NASTRAN solution sequence for static analysis of finite element models with symmetrical geometry
- DCL Digital Control Language (used with VAX computers)
- DH See **Material Control Input**.
- DL1 See **Material Control Input**.
- DL2 See **Material Control Input**.
- DMAP Direct Matrix Abstraction Programming
- DW See **Material Control Input**.
- EDF Empirical distribution function

EIGEN See **Subroutine Descriptions**.

ELEM See **Subroutine Descriptions**.

EVALP3 See **Subroutine Descriptions**.

EXEC Computer control command language for the VM/CMS operating system

EXECUTIVE CONTROL DECK Provides user control over the MSC/NASTRAN executive functions

°F Temperature in degrees Fahrenheit

FINDP See **Subroutine Descriptions**.

FORTRAN77 Scientific computer language (FORMula TRANSlation), version 77

g Mass in grams

GAUSS See **Subroutine Descriptions**.

GC Griffith crack

GN Griffith notch

GPa Pressure in gigapascals

HEXA Six-sided solid isoparametric element

IASEND See **Subroutine Descriptions** for subroutine SORTII.

IBM VM/CMS Software used by AMDAHL computer at NASA Lewis for its operating system

ID1 See **Material Control Input**.

ID2S See **Material Control Input**.

ID2V See **Material Control Input**.

ID3S See **Material Control Input**.

ID3V See **Material Control Input**.

ID4 See **Material Control Input**.

IKBAT See **Material Control Input**.

in. Dimensions in inches

INDEX See **Subroutine Descriptions** for subroutines SORTI and SORTRI.

INTER See **Subroutine Descriptions**.

INTVAL See **Subroutine Descriptions** for subroutines ANGLES and SNGLES.

IP See **Subroutine Descriptions** for subroutines SHAPE2.

IPRINT See **Master Control Input**.

ISKIP See **Subroutine Descriptions** for subroutine OUTLIE.

JCL Job Control Language

K-S Kolmogorov-Smirnov goodness-of-fit test

lb Weight in pounds

LEAST2 See **Subroutine Descriptions**.

LOADCYH NASTRAN BULK DATA card to input harmonic load for cyclic symmetry problems

LOADCYN NASTRAN BULK DATA card to input physical load for cyclic symmetry problems

LONL See **Master Control Input**.

m Dimensions in meters

Master Control Input Set of control indices which directs the overall program execution of CARES

MATBAT See **Subroutine Descriptions**.

Material Control Input Set of control indices and the data required to estimate the statistical material parameters or direct input of the statistical parameter values for the CARES computer program

MATID See **Material Control Input**.

MATL See **Subroutine Descriptions**.

MAT1 NASTRAN material properties card

MAXL See **Subroutine Descriptions**.

MLE Maximum likelihood estimate

MLORLE See **Material Control Input**.

mm Dimensions in millimeters

MNR Maximum normed residual

MOEL See **Subroutine Descriptions** for subroutine ELEM.

MOR Modulus of rupture (see **Material Control Input**)

MPa Pressure in megapascals

MSC/NASTRAN MacNeal-Schwendler Corporation/NASA STRuctural ANalysis—a version of NASA’s general purpose finite element code

MSGMESH MSC/NASTRAN finite element mesh generation program

MUEST Multiaxial Elemental Strength model

NASTRAN NASA STRuctural ANalysis general purpose finite element code

NE See **Master Control Input**.

NGP Number of Gauss base points used in numerical integration (see **Master Control Input**)

NMATS See **Master Control Input**.

NMATV See **Master Control Input**.

NOEL See **Subroutine Descriptions** for subroutine ELEM.

NORMAL See **Subroutine Descriptions**.

NS See **Master Control Input**.

NSORT See **Subroutine Descriptions** for the sorting subroutines.

NUT See **Material Control Input**.

OUTLIE See **Subroutine Descriptions**.

PARAM See **Material Control Input**.

PARAM,EST MSC/NASTRAN Bulk Data card for obtaining element volumes and areas

PATRAN Finite element mesh generation program manufactured by PDA Engineering Inc.

PENTA Five-sided solid isoparametric element

PIA Principle of independent action (PIA) is a model for finding the failure probability of a brittle material in multidimensional stress fields

PR See **Material Control Input**.

PRINTA See **Subroutine Descriptions**.

PRINTB See **Subroutine Descriptions**.

PRINTO See **Subroutine Descriptions**.

PRINTP See **Subroutine Descriptions**.

PSC Penny-shaped crack

PSHELL MSC/NASTRAN Bulk Data card for shell element properties

psi Pressure in pounds per square inch

PSOLID MSC/NASTRAN Bulk Data card for solid element properties

QUAD8 Quadrilateral isoparametric shell element

rev Number of revolutions

RFORCE MSC/NASTRAN Bulk Data card to define rotational force

Rigid Format 24 (STATICS) solution method for MSC/NASTRAN static analysis

Rigid Format 47 (CYCLIC STATICS) solution method for MSC/NASTRAN for cyclic symmetry static analysis

RINDEX See **Subroutine Descriptions** for subroutine SORTIR.

rpm Angular velocity in revolutions per minute

SC Semicircular crack

SCARE Structural Ceramics Analysis and Reliability Evaluation of Structures (the previous name of CARES)

SEANGL See **Subroutine Descriptions** for subroutines NORMAL and SORMAL.

sec Time in seconds

SET card NASTRAN Case Control card to define a set of elements

SHAPE1 See **Subroutine Descriptions**.

SHAPE2 See **Subroutine Descriptions**.

SHP2 See **Subroutine Descriptions** for subroutine SHAPE2.

SNGLES See **Subroutine Descriptions**.

Solution Sequence 38 (STATICS) solution method for MSC/NASTRAN static analysis (not the same as Rigid Format 24)

Solution Sequence 61 (SUPERELEMENT STATICS) solution method for MSC/NASTRAN static analysis using superelements

SORMAL See **Subroutine Descriptions**.

SORTI See **Subroutine Descriptions**.

SORTII See **Subroutine Descriptions**.

SORTIR See **Subroutine Descriptions**.

SORTR See **Subroutine Descriptions**.

SORTRA See **Subroutine Descriptions**.

SORTRI See **Subroutine Descriptions**.

SUBTITLE MSC/NASTRAN Executive Control card for specifying problem subtitle

SUPERELEMENT STATICS Solution method for MSC/NASTRAN static analysis using superelements (Solution Sequence 61)

SVALP3 See **Subroutine Descriptions**.

SX, SXY, SY, SYZ, SZ, SZX See **Subroutine Descriptions** for subroutine INTER.

TBUFF File used to store right-justified MSC/NASTRAN Bulk Data read by CARES

TDEG See **Material Control Input**.

TEMP MSC/NASTRAN Bulk Data card for assigning nodal temperature

TEMP* MSC/NASTRAN Bulk Data card for assigning nodal temperature using double-field-width input

TEMPD MSC/NASTRAN Bulk Data card for assigning default nodal temperature (used if some grid points do not have an explicit temperature assignment)

TEMPLET INP CARES input file containing the Master Control Input and the Material Control Input

TITLE See **Master Control Input** and **Material Control Input** (also MSC/NASTRAN executive control card for specifying problem title).

TRIA6 Triangular, isoparametric shell element

TRIAX6 Axisymmetric, isoparametric, triangular element

UNBIAS See **Subroutine Descriptions**.

UNICOS Version of the UNIX operating system for the CRAY supercomputer

VAGAGE See **Material Control Input**.

VAX Computer manufactured by Digital Equipment Corporation

VAXcluster Computer system manufactured by Digital Equipment Corporation

Version 64 Version of MSC/NASTRAN

Version 65 Version of MSC/NASTRAN

WLT Weakest-link theory

XEDIT Editing program for the VM/CMS operating system

\$ENDM See **Material Control Input**.

\$ENDT See **Material Control Input**.

\$ENDX See **Master Control Input**.

Appendix C

CARES.COM

CARES.COM Execution File for the VMS Operating System

```
$ ! THIS IS A VAX/VMS DCL COMMAND FILE TO ASSIGN THE LOGICAL UNITS TO THE
$ ! APPROPRIATE FILENAMES AND START EXECUTION OF CARES1 OR CARES2
$ ! TYPE @CARES TO EXECUTE THESE COMMANDS
$ INQUIRE FILE5 "CARES Input Filename" ! Read input filename
$ IF F$SEARCH ("''FILE5'") .EQS. "" THEN GOTO NOFILE5 ! Check input file
$ ASSIGN 'FILE5' FOR005 ! Assign input file
$ INQUIRE FILE1 "CARES Output Filename" ! CARES output file
$ ASSIGN 'FILE1' FOR001
$ INQUIRE MSC "Assign MSC/NASTRAN files (""Y"" or ""N""?) ?" ! Check for NASTRAN
$ IF ""MSC"" .EQS. "" THEN MSC = "Y" ! Return = "Y"
$ ! If MSC = N, do not assign NASTRAN files...execute CARES
$ IF .NOT. MSC THEN GOTO EXECUTE
$ INQUIRE FILE3 "MSC/NASTRAN Printout Filename" ! NASTRAN print file
$ IF F$SEARCH ("''FILE3'") .EQS. "" THEN GOTO NOFILE3
$ ASSIGN 'FILE3' FOR003
$ INQUIRE FILE7 "MSC/NASTRAN Punch Filename" ! NASTRAN punch file
$ IF F$SEARCH ("''FILE7'") .EQS. "" THEN GOTO NOFILE7
$ ASSIGN 'FILE7' FOR007
$ DELETE TBUFF.DAT;* ! Delete any previous TBUFF.DAT
$ ASSIGN TBUFF.DAT FOR004 ! Assign temporary buffer file
$ EXECUTE: ! All logical units have been assigned
$ INQUIRE VER "CARES1 or CARES2 (""1"" or ""2""?) ?"
$ IF ("''VER'".NES. "1" .AND. "''VER'".NES. "2") THEN GOTO EXECUTE
$ IF F$SEARCH ("CARES''VER'.EXE") .EQS. "" THEN GOTO NOCARES
$ WRITE SYS$OUTPUT "" ! Blank line
$ WRITE SYS$OUTPUT "EXECUTION OF CARES''VER' HAS BEGUN..."
$ RUN CARES''VER'
$ RELEASE: ! Release all logical unit assignments
$ DEASSIGN FOR005
$ DEASSIGN FOR001
$ IF .NOT. MSC THEN EXIT
$ DEASSIGN FOR003
$ DEASSIGN FOR007
$ DEASSIGN FOR004
$ EXIT ! End of normal execution
$ NOFILE5: ! Error...no input file
$ WRITE SYS$OUTPUT "''FILE5' NOT FOUND...EXECUTE CARES.COM AGAIN"
$ EXIT
$ NOFILE3: ! Error...no print file
$ WRITE SYS$OUTPUT "''FILE3' NOT FOUND...EXECUTE CARES.COM AGAIN"
$ DEASSIGN FOR005
$ EXIT
$ NOFILE7: ! Error...no punch file
$ WRITE SYS$OUTPUT "''FILE7' NOT FOUND...EXECUTE CARES.COM AGAIN"
$ DEASSIGN FOR005
$ DEASSIGN FOR003
$ EXIT
$ NOCARES: ! Error...no executable file
$ WRITE SYS$OUTPUT "CARES''VER'.EXE NOT FOUND..."
$ WRITE SYS$OUTPUT "COMPILE AND LINK CARES''VER'.FOR AND RUN CARES.COM AGAIN"
$ GOTO RELEASE
$ EXIT
```

References

- Griffith, A.A.: The Phenomena of Rupture and Flow in Solids. *Philos. Trans. R. Soc. London A*, vol. 221, 1921, pp. 163-198.
- Griffith, A.A.: The Theory of Rupture. *Proceedings of the 1st International Congress for Applied Mechanics*, C.B. Biezeno and J.M. Burgers, eds., Delft, 1924, pp. 55-63.
- Weibull, W.: A Statistical Theory of the Strength of Materials. *Ingeniors Vetenskaps Akademien Handlinger*, No. 151, 1939.
- Weibull, W.: The Phenomenon of Rupture in Solids. *Ingeniors Vetenskaps Akademien Handlinger*, No. 153, 1939.
- Weibull, W.: A Statistical Distribution Function of Wide Applicability. *J. Appl. Mech.*, vol. 18, no. 3, Sept. 1951, pp. 293-297.
- Pierce, F.T.: Tensile Tests for Cotton Yarns, V. The "Weakest Link" Theorems on the Strength of Long and of Composite Specimens. *Text. Inst. J.*, vol. 17, 1926, pp. T355-T368.
- Kontorova, T.A.: A Statistical Theory of Mechanical Strength. *J. Tech. Phys. (USSR)*, vol. 10, 1940, pp. 886-890.
- Frenkel, J.I.; and Kontorova, T.A.: A Statistical Theory of the Brittle Strength of Real Crystals. *J. Phys. (USSR)*, vol. 7, no. 3, 1943, pp. 108-114.
- Shih, T.T.: An Evaluation of the Probabilistic Approach to Brittle Design. *Eng. Fract. Mech.*, vol. 13, no. 2, 1980, pp. 257-271.
- Barnett, R.L., et al.: Fracture of Brittle Materials Under Transient Mechanical and Thermal Loading. U.S. Air Force Flight Dynamics Laboratory. AFFDL-TR-66-220, Mar. 1967.
- Freudenthal, A.M.: Statistical Approach to Brittle Fracture. *Fracture, An Advanced Treatise*, Vol. 2, *Mathematical Fundamentals*, H. Liebowitz, ed., Academic Press, 1968, pp. 591-619.
- Margetson, J.: A Statistical Theory of Brittle Failure for an Anisotropic Structure Subjected to a Multiaxial Stress State. *AIAA Paper 76-632*, July 1976.
- Paluszny, A.; and Wu, W.: Probabilistic Aspects of Designing with Ceramics. *J. Eng. Power*, vol. 99, no. 4, Oct. 1977, pp. 617-630.
- DeSalvo, G.J.: Theory and Structural Design Application of Weibull Statistics, WANL-TME-2688, Westinghouse Astronuclear Lab., 1970.
- Wertz, J.L., and Heitman, P.W.: Predicting the Reliability of Ceramic Turbine Components. *Advanced Gas Turbine Systems for Automobiles*, SAE-SP-465, Society of Automotive Engineers, 1980, pp. 69-77.
- Dukes W.H.: *Handbook of Brittle Material Design Technology*, AGARDograph 152. AGARD, Paris, France, 1971.
- Batdorf, S.B.; and Crose, J.G.: A Statistical Theory for the Fracture of Brittle Structures Subjected to Nonuniform Polyaxial Stresses. *J. Appl. Mech.*, vol. 41, no. 2, June 1974, pp. 459-464.
- Evans, A.G.; and Jones, R.L.: Evaluation of a Fundamental Approach for the Statistical Analysis of Fracture. *J. Am. Ceram. Soc.*, vol. 61, no. 3-4, Mar.-Apr. 1978, pp. 156-160.
- Batdorf, S.B.: Fracture Statistics of Polyaxial Stress States. *Fracture Mechanics*, N. Perrone, et al., eds., University Press of Virginia, 1976, pp. 579-591.
- Paul, B.; and Mirandy, L.: An Improved Fracture Criterion for Three-Dimensional Stress States. *J. Eng. Mater. Technol.*, vol. 98, no. 2, Apr. 1976, pp. 159-163.
- Giovan, M.N.; and Sines, G.: Biaxial and Uniaxial Data for Statistical Comparison of a Ceramic's Strength. *J. Am. Ceram. Soc.*, vol. 62, no. 9, Sept. 1979, pp. 510-515.
- Batdorf, S.B.: Comparison of the Best Known Fracture Criteria. Absorbed Specific Energy and/or Strain Energy Density Criterion, G. Sih, E. Czoboly, and F. Gillemot, eds., Martinus Nijhoff Publishers, 1982, pp. 243-251.
- Stout, M.G.; and Petrovic, J.J.: Multiaxial Loading Fracture of Al_2O_3 Tubes: I. Experiments. *J. Am. Ceram. Soc.*, vol. 67, no. 1, Jan. 1984, pp. 14-18.
- Petrovic, J.J.; and Stout, M.G.: Multiaxial Loading Fracture of Al_2O_3 Tubes: II, Weibull Theory and Analysis. *J. Am. Ceram. Soc.*, vol. 67, no. 1, Jan., 1984, pp. 18-23.
- Palaniswamy, K., and Knauss, W.G.: On the Problem of Crack Extension in Brittle Solids Under General Loading. *Mech. Today*, vol. 4, pp. 87-148, 1978.
- Shetty, D.K.: Mixed-Mode Fracture Criteria for Reliability Analysis and Design with Structural Ceramics. *J. Eng. Gas Turbines Power*, vol. 109, no. 3, July 1987, pp. 282-289.
- Schaeffer, H.G.: *MSC/NASTRAN Primer: Static and Normal Modes Analysis*. 2nd ed., Schaeffer Analysis Inc., Mount Vernon, NH, 1979.
- Gyekenyesi, J.P.: SCARE: A Postprocessor Program to MSC/NASTRAN for the Reliability Analysis of Structural Ceramic Components. *J. Eng. Gas Turbines Power*, vol. 108, no. 3, July 1986, pp. 540-546.
- Gyekenyesi, J.P.; and Nemeth, N.N.: Surface Flaw Reliability Analysis of Ceramic Components with the SCARE Finite Element Postprocessor Program. *J. Eng. Gas Turbines Power*, vol. 109, no. 3, July 1987, pp. 274-281.
- Pai, S.S.; and Gyekenyesi, J.P.: Calculation of the Weibull Strength Parameters and Batdorf Flaw-Density Constants for Volume- and Surface-Flaw-Induced Fracture in Ceramics. *NASA TM-100890*, 1988.
- Pintz, A.; Abumeri, G.H.; and Manderscheid, J.M.: CARES-ANSYS Structural Ceramics Reliability Analysis—Users Manual. *NASA CR* (to be published).
- Baratta, F.I.; Matthews, W.T.; and Quinn, G.D.: Errors Associated with Flexure Testing of Brittle Materials. *MTL-TR-87-35*, U.S. Army Materials Technology Laboratory, Watertown, MA, July 1987. (Avail. NTIS, AD-A187470).
- Liu, K.C.; and Brinkman, C.R.: Tensile Cyclic Fatigue of Structural Ceramics. *Proceedings of the 23rd Automotive Technology Development Contractors' Coordination Meeting*, Society of Automotive Engineers, Warrendale, PA, 1986, pp. 279-284.
- Stefansky, W.: Rejecting Outliers in Factorial Designs. *Technometrics*, vol. 14, no. 2, May 1972, pp. 469-479.
- Neal, D.; Vangel, M.; and Todt, F.: *Statistical Analysis of Mechanical Properties. Engineered Materials Handbook*, Vol. 1, Composites, ASM International, Metals Park, OH, 1987, pp. 302-307.
- Nelson, W.: *Applied Life Data Analysis*. Wiley, 1982, pp. 333-395.
- Johnson, L.G.: *The Statistical Treatment of Fatigue Experiments*. Elsevier Publishing Co., 1964, pp. 37-41.
- Thoman, D.R.; Bain, L.J.; and Antle, C.E.: Inferences on the Parameters of the Weibull Distribution. *Technometrics*, vol. 11, no. 3, Aug. 1969, pp. 445-460.
- D'Agostino, R.B.; and Stephens, M.A., eds.: *Goodness-of-Fit Techniques*. Marcel Dekker, 1986, pp. 97-193.
- Kanofsky, P.; and Srinivasan, R.: An Approach to the Construction of Parametric Confidence Bands on Cumulative Distribution Functions. *Biometrika*, vol. 59, no. 3, 1972, pp. 623-631.
- Ruffin, A.C.; Samos, D.R.; and Bollard, R.J.H.: Statistical Failure Prediction Models for Brittle Materials. *AIAA J.*, vol. 22, no. 1, Jan. 1984, pp. 135-140.
- Case, W.R.; and Vandegrift, R.E.: Accuracy of Three Dimensional Solid Finite Elements. *Twelfth NASTRAN Users' Colloquium*, NASA CP-2328, 1984, pp. 26-46.
- Tracy, P.G.; et al.: On Statistical Nature of Fracture. *Int. J. Fract.*, vol. 18, no. 4, Apr. 1982, pp. 253-277.
- Daniels, H.E.: The Statistical Theory of the Strength of Bundles of Threads. I. *Proc. R. Soc. London A*, vol. 183, 1945, pp. 405-435.
- Davies, D.G.S.: The Statistical Approach to Engineering Design in Ceramics. *Proc. Br. Ceram. Soc.*, no. 22, 1973, pp. 429-452.

46. Batdorf, S.B.: Some Approximate Treatments of Fracture Statistics for Polyaxial Tension. *Int. J. Fract.*, vol. 13, no. 1, Feb. 1977, pp. 5-11.
47. Gross, B., and Gyekenyesi, J.P.: Weibull Crack Density Coefficient for Polydimensional Stress States. *J. Am. Ceram. Soc.*, vol. 72, no. 3, Mar. 1989, pp. 506-507.
48. Batdorf, S.B.; and Heinisch, H.L., Jr.: Weakest Link Theory Reformulated for Arbitrary Fracture Criterion. *J. Am. Ceram. Soc.*, vol. 61, no. 7-8, July-Aug. 1978, pp. 355-358.
49. Sih, G.C.: *Handbook of Stress Intensity Factors*. Lehigh University, 1973.
50. Smith, F.W.; Emery, A.F.; and Kobayashi, A.S.: Stress Intensity Factors for Semi-Circular Cracks. *J. Appl. Mech.*, vol. 34, no. 4, Dec. 1967, pp. 953-959.
51. Smith F.W.; and Sorenson, D.R.: Mixed-Mode Stress Intensity Factors for Semielliptical Surface Cracks. NASA CR-134684, 1974.
52. Abernethy, R.B. et al.: Weibull Analysis Handbook. PWA/GPD-FR-17579, Pratt and Whitney Aircraft, Nov. 1983. (Avail. NTIS, AD-A143100).
53. Rufin, A.C.: A Study of Statistical Failure Prediction Models for Brittle Materials Subjected to Multiaxial States of Stress, M.S. Thesis Univ. Washington, 1981.
54. Samos, D.R.: Experimental Investigation and Probability of Failure Analysis of Pressure Loaded Alumina Discs, M.S. Thesis, Univ. of Washington, 1982.
55. Swank, L.R.; and Williams, R.M.: Correlation of Static Strengths and Speeds of Rotational Failure of Structural Ceramics. *Am. Ceram. Soc. Bull.*, vol. 60, no. 8, Aug. 1981, pp. 830-834.
56. Brockenbrough, J.R.; Forsythe, L.E.; and Rolf, R.L.: Reliability of Brittle Materials in Thermal Shock. *J. Am. Ceram. Soc.*, vol. 69, no. 8, Aug. 1986, pp. 634-637. (Alcoa Laboratories, Rept. No. 52-85-22).
57. Bruckner-Foit, A.; and Munz, D.: Statistical Analysis of Flexure Strength Data. IEA Annex II, Subtask 4. Institute fur Zuverlassigkeit und Schadenskunde in Maschinenbau University of Karlsruhe, P.O. Box 3640, D-7500 Karlsruhe, West Germany, 1988.
58. Tennery, V.J.: IEA Annex II Management, Subtask 4 Results. Ceramic Technology for Advanced Heat Engines Project, Semiannual Progress Report, Oct. 1986-Mar. 1987. ORNL/TM-10469, Martin Marietta Energy Systems, Inc., Oak Ridge, TN, 1987.
59. Shetty, D.L.; Rosenfield, A.R.; and Duckworth, W.H.: Statistical Analysis of Size and Stress State Effects on the Strength of an Alumina Ceramic. Methods for Assessing the Structural Reliability of Brittle Materials, ASTM-STP-844, S.W. Frieman and C.M. Hudson, eds., American Society for Testing and Materials, 1984, pp. 57-80.
60. Shetty, D.K.; et al.: A Biaxial-Flexure Test for Evaluating Ceramic Strengths. *J. Am. Ceram. Soc.*, vol. 66, no. 1, pp. 36-42, Jan. 1983.
61. Lamon, J.: Statistical Approaches to Failure for Ceramic Reliability Assessment. *J. Am. Ceram. Soc.*, vol. 71, no. 2, Feb. 1988, pp. 106-112.
62. Boulet, J.A.M.: An Assessment of the State of the Art in Predicting the Failure of Ceramics. ORNL/SUB-86-57598/1, Mar. 1988.
63. Lamon, J.: Ceramics Reliability—Statistical Analysis of Multiaxial Failure Using the Weibull Approach and the Multiaxial Elemental Strength Models, ASME Paper 88-GT-147, 1988.
64. Carnahan, B.; Luther, H.A.; and Wilkes, J.D.: *Applied Numerical Methods*, John Wiley and Sons, Inc., 1969.

1. Report No. NASA TP-2916		2. Government Accession No.		3. Recipient's Catalog No.	
4. Title and Subtitle Ceramics Analysis and Reliability Evaluation of Structures (CARES) Users and Programmers Manual				5. Report Date August 1990	
				6. Performing Organization Code	
7. Author(s) Noel N. Nemeth, Jane M. Manderscheid, and John P. Gyekenyesi				8. Performing Organization Report No. E-4722-1	
				10. Work Unit No. 505-63-1B	
9. Performing Organization Name and Address National Aeronautics and Space Administration Lewis Research Center Cleveland, Ohio 44135-3191				11. Contract or Grant No.	
				13. Type of Report and Period Covered Technical Paper	
12. Sponsoring Agency Name and Address National Aeronautics and Space Administration Washington, D.C. 20546-0001				14. Sponsoring Agency Code	
15. Supplementary Notes Noel N. Nemeth, Aerospace Design & Fabrication, Inc., 16101 Snow Road, Brook Park, Ohio 44142; Jane M. Manderscheid and John P. Gyekenyesi, NASA Lewis Research Center.					
16. Abstract <p>This manual describes how to use the Ceramics Analysis and Reliability Evaluation of Structures (CARES) computer program. The primary function of the code is to calculate the fast-fracture reliability or failure probability of macroscopically isotropic ceramic components. These components may be subjected to complex thermomechanical loadings, such as those found in heat engine applications. The program uses results from MSC/NASTRAN or ANSYS finite element analysis programs to evaluate component reliability due to inherent surface and/or volume type flaws. CARES utilizes the Batdorf model and the two-parameter Weibull cumulative distribution function to describe the effect of multiaxial stress states on material strength. The principle of independent action (PIA) and the Weibull normal stress averaging models are also included. Weibull material strength parameters, the Batdorf crack density coefficient, and other related statistical quantities are estimated from four-point bend bar or uniform uniaxial tensile specimen fracture strength data. Parameter estimation can be performed for single or multiple failure modes by using the least-squares analysis or the maximum likelihood method. Kolmogorov-Smirnov and Anderson-Darling goodness-of-fit tests, ninety-percent confidence intervals on the Weibull parameters, and Kanofsky-Srinivasan ninety-percent confidence band values are also provided. The probabilistic fast-fracture theories used in CARES, along with the input and output for CARES, are described. Example problems to demonstrate various features of the program are also included. This manual describes only the MSC/NASTRAN version of the CARES program.</p>					
17. Key Words (Suggested by Author(s)) Ceramic strength; Weibull; MOR bars; Censored data; Least squares; Maximum likelihood; Confidence bands; Finite elements; Ceramic design; Fast fracture; Batdorf; MSC/NASTRAN; SCARE; CARES			18. Distribution Statement Unclassified - Unlimited Subject Category 39		
19. Security Classif. (of this report) Unclassified		20. Security Classif. (of this page) Unclassified		21. No. of pages 232	22. Price* A11