

24

511-74  
N<sup>o</sup> 91 - P9137

OPTICAL TESTING CRYOGENIC THERMAL VACUUM FACILITY <sup>1</sup>

Patrick W. Dohogne and Warren A. Carpenter  
CBI Technical Services Co.

ci 218471

ABSTRACT

The construction of a turnkey cryogenic vacuum test facility was recently completed by CBI at Griffiss AFB's Rome Air Development Center (RADC). The facility will be used to measure and record the surface profile of large (up to 2 m (6.5 ft) diameter and 540 kg (1200 lb)) optics under simulated space conditions.

The vacuum test chamber is a vertical stainless steel cylinder with a 3.5 m (11.5 ft) diameter and a 7 m (23 ft) tangent length. The cylinder is comprised of two flanged spool sections to accommodate different test configurations. Laser interferometers are mounted on optical benches located on the top chamber head. The surface profile of the test specimen is measured by the interferometer viewed through a 46 cm (18 in) diameter optical port. The chamber interior is accessed by pneumatically lowering the bottom chamber head into a pit with four pneumatic cylinders.

The chamber was designed to maximize optical testing quality by minimizing the vibrations between the laser interferometer and the test specimen. This was accomplished by designing the chamber for a high natural frequency and vibration isolating the chamber.

An optical test specimen is mounted on a movable presentation stage. The presentation stage provides coarse elevation adjustment to +/- 0.158 cm (1/16 in) accuracy of the specimen from 0 to 90 cm (0 to 36 in). During thermal vacuum testing, the specimen may be positioned to +/- 0.00025 cm (0.0001 in) accuracy with a fine adjustment mechanism.

The chamber is evacuated by a close coupled Roots-type blower and rotary vane pump package and two cryopumps. The vacuum system is designed to evacuate the chamber to  $1.1 \times 10^{-3}$  Pa ( $8.0 \times 10^{-6}$  torr) in less than five hours with the thermal shrouds at ambient temperature. A chamber pressure of  $2.7 \times 10^{-6}$  Pa ( $2.0 \times 10^{-8}$  torr) was measured with a nude ionization gauge during performance testing with cold thermal shrouds.

<sup>1</sup> Constructed under contract to Rome Air Development Center, Griffiss Air Force Base, NY

The chamber is equipped with an optically dense gaseous nitrogen cooled thermal shroud. Remote controlled shutters on top of the shroud are opened after specimen temperature stabilization to allow interferometry measurements.

The thermal shroud is used to cool or warm the optical test specimen at a controlled rate. To minimize test specimen thermal stresses, a differential temperature control system is utilized. The control system automatically controls the thermal shroud temperature to maintain the test specimen temperature gradient within safe tolerance.

A control system is provided to automatically evacuate the chamber and cooldown the test specimen to the selected control temperature. After initial control inputs, the control system automatically functions without operator input.

## INTRODUCTION

CBI has constructed a state-of-the-art turnkey thermal vacuum facility for testing optics under simulated space conditions at Griffiss AFB's Rome Air Development Center (see Figure 1). The facility will use two RADC-supplied laser interferometers to measure and record the surface profile of large optics which are exposed to cryogenic and vacuum environments. An optic which has been tested by RADC and a comparison of the optic's room temperature and cryogenic surface profiles are shown in Figures 2 and 3. The project was a competitively bid, fixed price contract to provide a complete test facility including a building addition to house the new facility. The contract was awarded in May 1987 and the facility was completed in June 1989.

The test chamber is a vibration isolated vertical cylinder with a 3.5 m (11.5 ft) diameter and a 7 m (23 ft) tangent length (see Figure 4). The chamber is equipped with an optically dense shroud and thermal system capable of maintaining any temperature in a range from 100 K to 300 K. The thermal control system is designed to control test specimen temperatures to very stringent tolerances. A unique presentation stage and fine elevation adjustment system were designed and constructed to allow precise remote positioning of the test specimens while the chamber is under vacuum. Provisions have been made for the future addition of a 20 K helium supply system and thermal shroud.

Some of the key facility features required by RADC included:

- A minimum overall natural frequency of 30 hertz for the entire chamber assembly including the presentation stage.
- A presentation stage capable of coarse specimen elevation

adjustment from 0 to 90 cm (0 to 36 inches).

- A three point specimen elevation fine adjustment system with a 2.5 cm (1 inch) travel range and 0.0025 cm (0.001 inch) resolution.
- A five hour pumpdown from atmospheric pressure to  $1.1 \times 10^{-3}$  Pa ( $8.0 \times 10^{-6}$  torr).
- A thermal system capable of maintaining a constant test specimen temperature within the temperature range of 100 K to 300 K.
- A test specimen temperature control system capable of maintaining the differential temperature across the specimen to less than 15 K.
- A data acquisition system capable of monitoring and recording shroud and test specimen temperatures and chamber pressure.
- A facility control system equipped with an automatic pumpdown sequence.

During facility performance testing, all RADC specifications were met or improved upon.

#### TEST FACILITY BUILDING AND SYSTEMS

The building addition provided by CBI is designed to meet all of RADC's testing needs. The building is a four story structure which houses the vacuum chamber, a mechanical equipment room for the pumping and thermal system skids, a mezzanine area for storage and office space, a ground floor delivery/storage/cleaning area for test specimens, and additional office and laboratory areas. The building is designed to allow the installation of additional equipment for future expansion of the facility. The building was completed first and the vacuum chamber and subsystems were added at a later date. A removable roof hatch was used to facilitate installation of the vacuum chamber with a crane.

The building is equipped with a 3 ton, two axis crane for transporting test specimens, moving the top chamber head and upper spool piece, and for performing maintenance tasks on the shroud and other chamber-mounted equipment. The chamber test area is also equipped with a temperature and humidity controlled Class 100,000 clean room air conditioning system.

## VACUUM CHAMBER

### PHYSICAL CHARACTERISTICS

The vacuum chamber is a vertical cylinder with a 3.5 m (11.5 ft) outer diameter and a 7 m (23 ft) tangent length. The cylinder is comprised of two flanged spool sections to accommodate different test configurations. The upper spool piece is 2.13 m (7 ft) in length and may be removed from the main chamber spool piece with an overhead crane. A stiffened support ring located at the top of the main chamber spool piece is used to support the vessel on vibration isolators. Two external ring stiffeners are welded to the vessel shell to provide additional stiffness and strength.

The top chamber head is a 3.5 m (11.5 ft) diameter ASME flanged and dished (F and D) head. The top head may also be removed from the vessel with the overhead crane. The head is equipped with a 46 cm (18 in) diameter viewport and two optical benches (see Figure 5). The viewport is fabricated from BK-7 glass and has a special coating applied to its surfaces to reduce reflectivity to 0.4% throughout the wavelength range of the two interferometers.

The bottom chamber head is also a 3.5 m (11.5 ft) diameter ASME F and D head. The chamber interior is accessed by lowering the head into a pit with four pneumatic cylinders (see Figure 6). The bottom head handling system is designed to keep the head level while it is travelling and to consistently locate the head in the proper presentation stage loading and chamber closing positions. External stiffeners welded to the head provide the required stiffness and strength to support the presentation stage and test specimen.

The vessel is equipped with 49 nozzles. The nozzles are used for shroud inlet and outlet connections, vacuum and repressurization system connections, electrical feedthru ports, the fine adjustment system, and multi-purpose use ports for use by RADC. Twenty-three hardpoints are provided on the top head and cylindrical shell for mounting RADC-supplied equipment.

The vessel shell, heads, nozzles, and all internal fixtures are fabricated from Type 304 stainless steel polished to a No. 4 finish. All external stiffeners, pad plates, and attachments are fabricated from A36 carbon steel.

### CHAMBER VIBRATION ISOLATION

The vacuum chamber and ancillary equipment are designed to minimize vibration transmission to the optical test specimen and laser interferometers. The entire chamber assembly including the presentation stage was required to have an overall natural frequency of at least 30 hertz. The following features are incorporated into the chamber design to ensure that the chamber vibration criteria are

met:

- Four pneumatic vibration isolators with 1.5 hertz vertical natural frequencies and 9070 kg (20,000 lb) load capacities are used to vibration isolate the chamber. The isolators are located beneath the stiffened support ring located at the top of the main chamber spool piece.
- Several in-house finite element analyses were performed to determine the optimum chamber and presentation stage stiffening arrangement to meet the 30 hertz natural frequency requirement. Analyses results indicated that a combination of external chamber stiffeners on the vessel shell and bottom head, an internal presentation stage rail support structure, and adjustable length presentation stage stiffening members would be required to meet this criteria.
- All piping and wiring directly connected to the chamber are vibration isolated by using stainless steel bellows and flexible conduit.
- Rotating equipment (such as mechanical vacuum pumps) are mounted on elastomeric isolator pads to minimize vibration transmission to the vacuum chamber. If necessary, rotating equipment is shut off during interferometer testing.

The natural frequency of the entire chamber assembly was calculated to be 31 hertz.

## OPTICS HANDLING SYSTEM

### PRESENTATION STAGE

Optical test specimens as large as 2 m (6.5 ft) in diameter and weighing up to 540 kg (1200 lb) may be mounted on a moveable presentation stage (see Figure 7). The presentation stage is used to load optical specimens into the vacuum chamber and to provide coarse elevation adjustment of the specimen from 0 to 90 cm (0 to 36 in). A scissors-type lift is used to provide coarse elevation adjustment of the presentation stage and is accurate to +/- 0.158 cm (1/16 in).

The presentation stage is manually rolled into the chamber on floor-mounted rails. Removable rail pieces are used to temporarily bridge the gap between the building floor and the rail support structure inside the vessel.

The scissors lift is powered by a frequency controlled electric motor and a gear reducer which are mounted on a separate, mobile cart. The presentation stage and power cart are temporarily connected by a universal-jointed drive shaft. Coarse elevation adjustment may be made inside or outside of the chamber. However,

the power cart is not vacuum compatible and must be removed from the chamber prior to testing.

After the optical specimen has been raised to the proper elevation, the presentation stage is bolted to the rail support structure. Adjustable length stiffening members are then bolted between the presentation stage and the rail support structure to increase the overall natural frequency of the structure.

The rail structure is attached to the bottom head with eight Invar restraint rods which provide horizontal stiffness to the rail structure and presentation stage. The rail structure, presentation stage and optical test specimen are supported by the three point fine adjustment drive system.

The presentation stage and rail support structure were fabricated primarily from Type 304 stainless steel. Bolts and other threaded connections were fabricated from bronze to prevent galling. Sliding or moving parts which require lubrication were coated with Teflon (manufactured by E. I. du Pont de Nemours & Co.) or a vacuum-compatible dry lubricant such as tungsten disulfide.

#### FINE ADJUSTMENT DRIVE SYSTEM

A remote-controlled, three point elevation adjustment system is provided to allow precise positioning of the optical test specimen while the chamber is at both cryogenic and vacuum conditions. The system is comprised of three equally spaced fine adjustment drive mechanisms (see Figure 8). Each drive mechanism has a vertical post which is used to support the rail structure, presentation stage and optical test specimen. The posts penetrate the bottom head through bellows-sealed nozzles. The bellows are used to maintain chamber vacuum integrity while the posts move in the vertical direction. The posts are supported by beams which are attached to the bottom head with hinge mechanisms. Each post has a roller to allow movement between the beam and the post. The posts are located very close to the hinged end of the beams to provide motion reduction from the jack screw drive system. The opposite ends of the beams are connected to ball-type jack screws with a 0.025 cm (0.01 in) pitch. Each jack screw drive is equipped with a stepping motor and a fail-safe magnetic brake.

The stepping motors are used to drive the ball screws. The motion of the ball screws in the vertical direction causes the free end of the beam and the vertical support posts to travel up and down. The lever action of the beam reduces the support post travel by a factor of 15. This, in combination with the slow stepping motor speeds and the fine pitch of the ball screws enable the fine adjustment mechanisms to position the optical test specimen to +/- 0.00025 cm (0.0001 in) resolution over a total travel range of +/- 1.27 cm (0.5 in) from the initial presentation stage loading position. This design provided RADC with an adjustment system that

has a resolution ten times better than specified.

Limit switches are installed on each drive mechanism to prevent them from exceeding travel limits. The limit switches are also used to indicate when the mechanisms are in the initial presentation stage loading position.

The fine adjustment mechanisms are operated from a portable control panel located near the optical benches. A stepping motor programming/control panel is provided to control the motion of the stepping motors. One stepping motor may be operated at a time from the control panel. Stepping motor rotational direction, speed, and travel distance are manually controlled by the operator or programmed into the stepping motor indexers for automatic operation. Indicator lights operated by the drive mechanism limit switches are also provided to show position status.

#### VACUUM PUMPING SYSTEM

The vacuum pumping system is capable of evacuating the 76.5 m<sup>3</sup> (2700 ft<sup>3</sup>) chamber from atmospheric pressure to 1.1 x 10<sup>-3</sup> Pa (8.0 x 10<sup>-6</sup> torr) in less than five hours with the shrouds at room temperature. The vacuum pumping system is comprised of a two stage mechanical pumping package and two cryopumps.

The Leybold, Inc. close coupled mechanical pump package is designed to evacuate the chamber from atmospheric pressure to 2.7 Pa (0.02 torr) in less than two hours. The pumps are also used to evacuate and regenerate the cryopumps. A mechanically refrigerated, optically dense cold trap is installed in the chamber roughing line as protection against oil backstreaming into the chamber.

Two Leybold, Inc. cryopumps are used to evacuate the chamber from a pressure of 2.7 Pa (0.02 torr) to a pressure of 1.1 x 10<sup>-3</sup> Pa (8.0 x 10<sup>-6</sup> torr) in less than 3 hours. The pumps have a gross nitrogen pumping speed of 10,000 l/s. The pumps are equipped with remote start/stop capability and a GN<sub>2</sub> regeneration system.

During performance testing, the vacuum pumping systems evacuated the chamber to a pressure of 1.1 x 10<sup>-3</sup> Pa (8.0 x 10<sup>-6</sup> torr) within the timespan specified by RADC. A chamber pressure of 2.7 x 10<sup>-6</sup> Pa (2.0 x 10<sup>-8</sup> torr) was measured by a nude ionization gauge while the thermal shrouds were at a temperature of 100 K.

The chamber repressurization system is equipped with a throttling valve to allow variable chamber repressurization rates. The system is capable of repressurizing the chamber in less than 30 minutes. The air used to repressurize the chamber is filtered through a high efficiency particulate (HEPA) filter to minimize chamber contamination.

The chamber roughing line, the cryopumps, and the chamber repressurization system are isolated from the chamber with electro-pneumatically operated high vacuum gate valves. The valves were directly mounted on the chamber nozzles.

## THERMAL SYSTEM

### THERMAL SHROUDS

The thermal shroud is designed to provide a 3.2 m (10.5 ft) diameter by 3.05 m (10.0 ft) high optically dense working volume for cryogenic testing of optical test specimens. The thermal shroud is comprised of 7 flow-adjustable control zones. Four 3.05 m (10 ft) high shroud zones are used to form the cylindrical working volume around the rail assembly, presentation stage, and test specimen. The ends of the cylinders are covered by cone-shaped shroud sections. A rectangular-shaped cold plate is installed on the presentation stage to cryogenically shield the bottom of the test specimen from the "warm" presentation stage.

To maximize radiation heat transfer between the thermal shroud and the test specimen, the shroud interior surfaces have been painted with a high emissivity black paint. To minimize radiation heat transfer between the thermal shroud and the chamber shell, the exterior shroud surfaces have been electropolished.

Individual inlets and outlets are provided for each shroud section. Removeable vacuum jacketed flex hoses are used to minimize vibration transmission to the vessel and to allow the shrouds to be easily removed from the chamber. Each shroud outlet is equipped with a remote-controlled valve to allow balanced gas flow through each section, thus minimizing the temperature gradient throughout the entire shroud system.

The top shroud cone has a 1.8 m (6 ft) hole to permit interferometer measurements to be made. To maintain optical density and to ensure uniform specimen cooldown, the hole is covered with two conductively cooled, semi-circular covers. The interior surface of the covers are painted black and the exterior surface is covered with multi-layer insulation (MLI) to minimize heat transfer from the vessel shell. Braided copper straps are bolted to the covers and to the top cone to provide conductive cooling. The covers are remotely opened and closed during interferometer testing by cable and pulley systems which are driven by two externally mounted, pneumatically powered rack and pinion gear mechanisms. The pulley drive shafts penetrate the chamber through an O-ring sealed rotary feedthrus.

Penetrations are provided in the shroud to allow access from the chamber interior to the multi-purpose ports. The penetrations are normally covered with conductively cooled aluminum port covers. Provisions have also been made for the future addition of a 20 K



helium shroud to be installed inside the existing working volume.

## THERMAL SYSTEM EQUIPMENT

The thermal system is a closed-loop GN<sub>2</sub> system designed to maintain the thermal shrouds at any temperature in a range from 100 K to 300 K. The equipment used to circulate the GN<sub>2</sub> through the shrouds to maintain the desired temperature includes a cryogenic blower, liquid nitrogen heat exchanger, electric heater, and all associated piping and valving between the individual components and the thermal shrouds.

The thermal system blower is a water-cooled, stainless steel centrifugal blower which is designed to provide a mass flow rate of 2040 kg/hr (4500 lb/hr) at a boost of 69 kPa (10 psi). The blower is equipped with a close-coupled encapsulated motor to eliminate the maintenance requirements associated with cryogenic blowers equipped with mechanical seals. The blower is equipped with heaters, thermocouples, and temperature controllers to automatically maintain proper bearing temperatures when the thermal system is operating at cryogenic temperatures.

Cryogenic cooling is provided by a stainless steel heat exchanger. LN<sub>2</sub> flows into one side of the exchanger and is vaporized by the GN<sub>2</sub> circulating through the other side of the exchanger. The flow of LN<sub>2</sub> into the exchanger is regulated by a modulating control valve.

A cryogenic-compatible electric heater is used for warming the shroud and test specimen. The heater output is regulated by an SCR controller.

## DATA ACQUISITION AND CONTROL SYSTEM

### DATA ACQUISITION SYSTEM

The data acquisition system consists of a Hewlett Packard HP 9000 computer and a HP 3852 data acquisition/control unit. The system is programmed to monitor 14 shroud temperatures (inlet and outlet temperature of each shroud zone), 20 test specimen temperatures, and the chamber pressure. Type T thermocouples are used to measure temperature and a combination of Convector (manufactured by Granville-Phillips Co.) and ionization gauges are used to measure chamber pressure. The system is configured to store the data on computer disks for future analysis. A user-friendly, menu-driven control program was written to allow facility operators to easily run the system. The control program allows the operator to change data sampling rates during long duration tests.

## THERMAL SYSTEM CONTROLLER

The data acquisition system is also used in conjunction with a PID controller to maintain the shroud and test specimen temperatures within operator specified tolerances. A menu-driven control program is used to specify the following operating parameters:

- Final test specimen temperature. This parameter may have any value in the temperature range of 100 K to 300 K.
- Maximum allowable temperature difference between any two points on the test specimen. Some test specimens are sensitive to thermal stresses/distortion and therefore cannot tolerate a large differential temperature. The minimum value for this parameter is 3 K.
- Maximum allowable temperature difference between the average shroud and average test specimen temperatures. A large value for this parameter increases the heat transfer rate between the test specimen and the thermal shroud. This in turn decreases the time required to warm or cool the specimen to the desired temperature. However, those test specimens which are sensitive to thermal stresses must be cooled or warmed at a slow, uniform rate. The minimum value for this parameter is 6 K.

These parameters may be changed at any time during testing from a menu displayed on the computer monitor.

The data acquisition system is programmed to measure the shroud and test specimen temperatures every 15 seconds. Based on the test specimen and shroud temperatures and the given operator parameters, the program calculates and transmits a temperature setpoint to the controller. The controller regulates the operation of the heat exchanger LN<sub>2</sub> control valve and the electric heater SCR to maintain the test specimen and shroud temperatures within operating limits. Local displays on the data acquisition controller and the temperature controller are used to alert the operator if a thermocouple fails, a fault exists in the data acquisition system, or if one of the operator specified parameters is exceeded. The control system is also equipped with a manual override capability to allow the operator to change the shroud temperature setpoint or to change the operational status of the LN<sub>2</sub> control valve or the electric heater.

Since the primary objective of the thermal system is to uniformly cool or warm test specimens, RADDC specifications did not require a specific shroud temperature ramp rate. To ensure that a specimen is cooled uniformly, the shroud temperature ramp rate is limited to 0.4 K/min (0.7° F/min) by the thermal system controller.

## FACILITY CONTROL SYSTEM

Most of the facility equipment is operated from a main control console located next to the chamber bottom head. The vacuum systems, the repressurization system, the thermal system, the  $\text{GN}_2$  utility system, and the data acquisition system are operated from this central station. The controls and indicators for these systems are part of a graphic schematic of the vacuum and test facility systems. A programmable logic controller (PLC) is used to control equipment sequencing and interlocking.

The control system is equipped with an automatic pumpdown sequence. Once initiated, the control system will automatically evacuate the chamber, start the thermal system, and cool the test specimen to the desired temperature. System operation may also be manually controlled by facility operators from the main control console.

A locally mounted control panel is provided to control the operation of the bottom head handling system. As previously discussed, a portable fine adjustment drive control panel is located near the optical benches at the top of the chamber. The top cone shroud cover movement systems are also controlled from this panel.

## UTILITY SUPPLY SYSTEMS

The facility is equipped with a 22,700 liter (6000 gallon)  $\text{LN}_2$  storage dewar. An electric  $\text{LN}_2$  vaporizer is used to provide  $\text{GN}_2$  to all pneumatic users. These users include the bottom head handling system, the cryopump regeneration system, the top cone shroud cover movement system, and all air operated valves.

## SUMMARY

Several innovative design approaches were utilized by CBI to meet RADC's needs for testing large optics under vacuum and cryogenic conditions. The key areas which were identified as critical to the successful design of the facility included:

- . Overall chamber natural frequency and vibration isolation system
- . Presentation stage and fine adjustment system
- . Thermal control system

CBI utilized finite element analysis techniques during the design stages of this project to ensure that the overall natural frequency of the chamber, presentation stage, and optical benches was at least 30 hertz. The integration of this design with the pneumatic

vibration isolation system allowed CBI to meet RADC's need for a stable testing platform.

CBI's innovative design of the presentation stage and fine adjustment system provided RADC a versatile system for transporting and positioning optics in the vacuum chamber. The design concept used for the fine adjustment system provided RADC ten times better resolution than required.

The thermal control system utilizes a CBI developed software package to precisely regulate the optic temperature, thermal gradient across the optic, and the shroud temperature to minimize thermal stresses and distortion in the optic. The software package is a user friendly, menu driven program which is also capable of storing large quantities of thermal test data.

During facility performance testing, it was demonstrated the facility met or improved upon all RADC requirements. The facility has been successfully used by RADC to test optics under cryogenic and vacuum conditions.

ORIGINAL PAGE  
BLACK AND WHITE PHOTOGRAPH

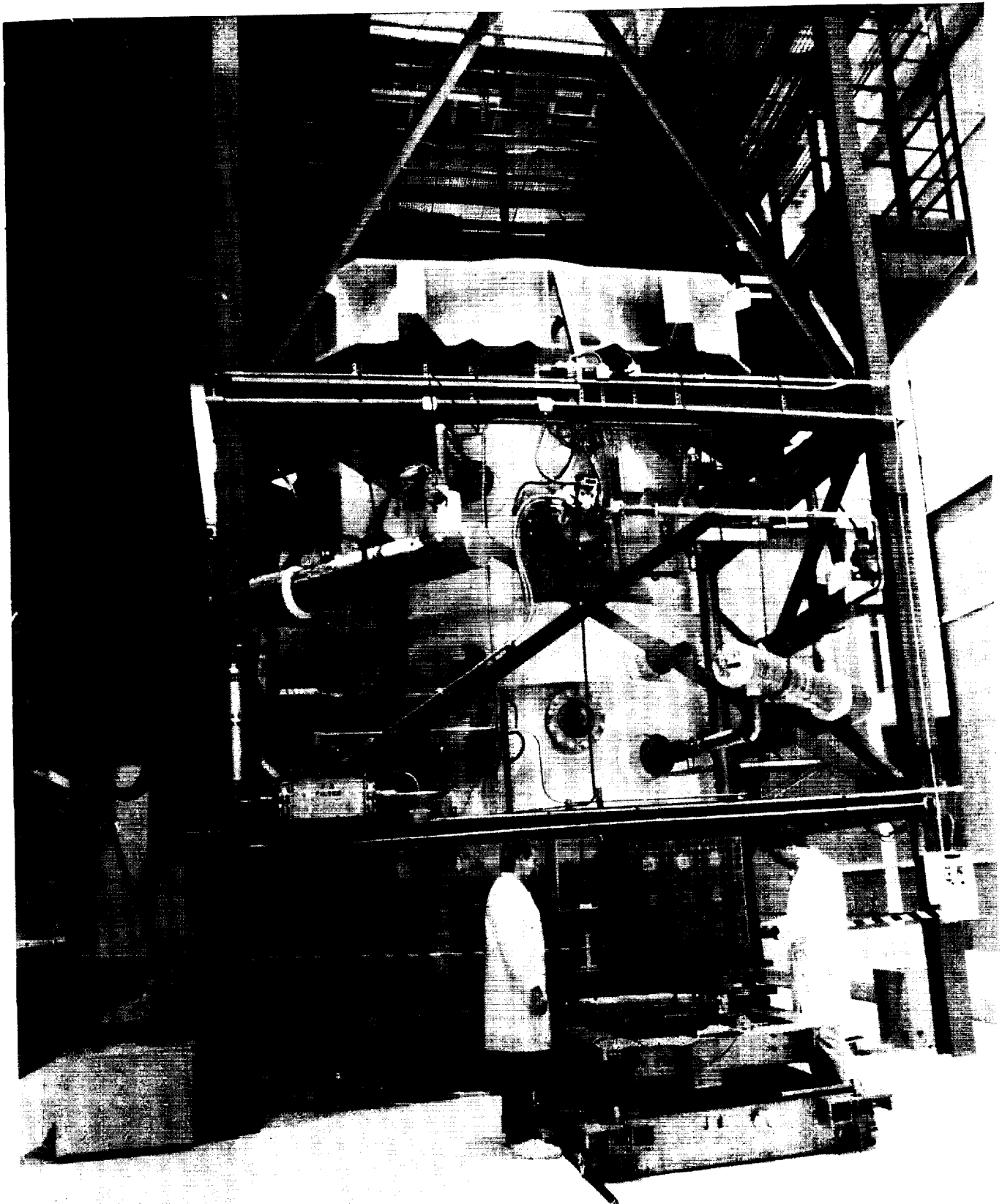

FIGURE 1: RADC THERMAL VACUUM TEST FACILITY

ORIGINAL PAGE  
BLACK AND WHITE PHOTOGRAPH

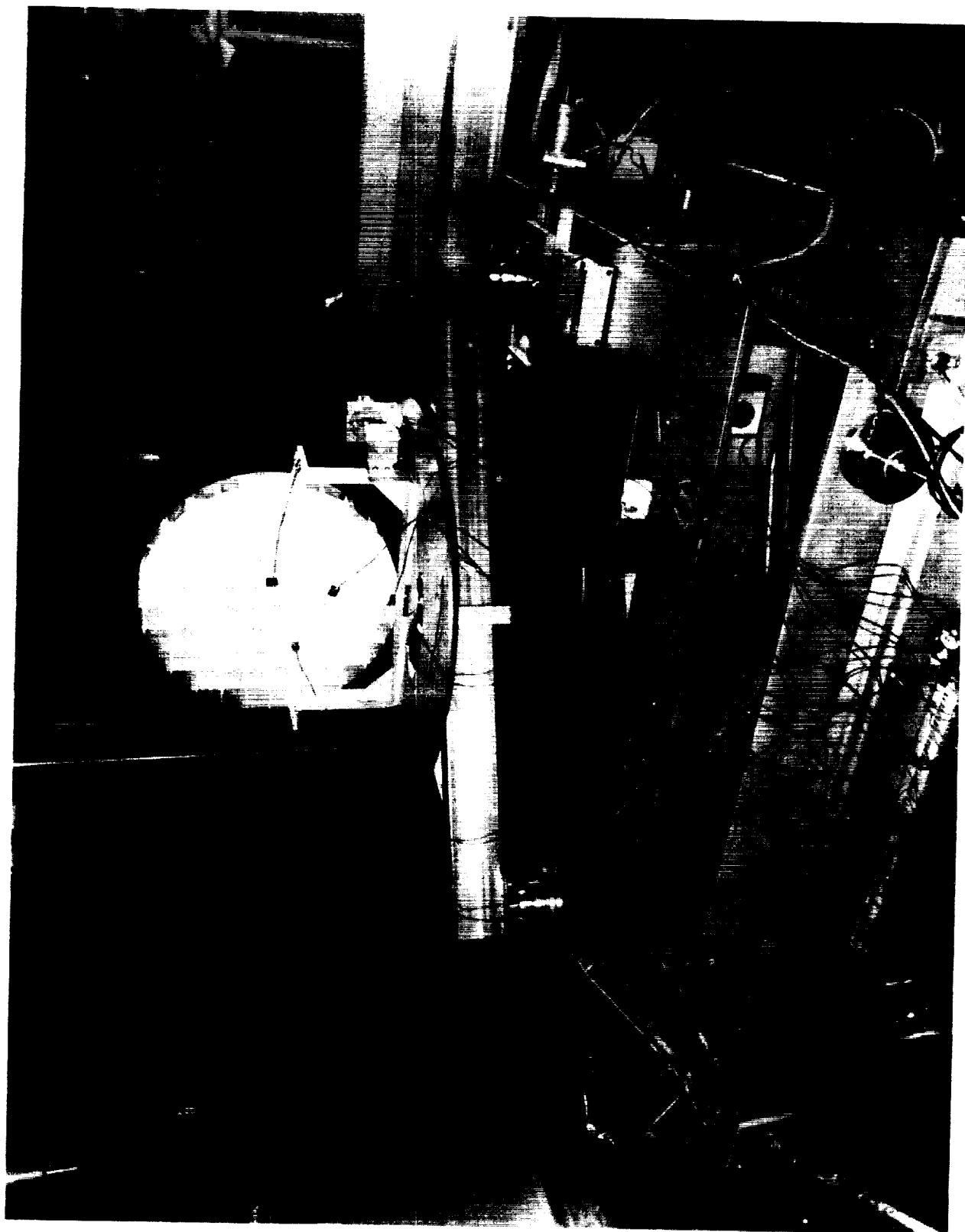

FIGURE 2: TEST OPTIC MOUNTED ON PRESENTATION STAGE

**0.5 Meter Frit-bonded Mirror Phase Maps**

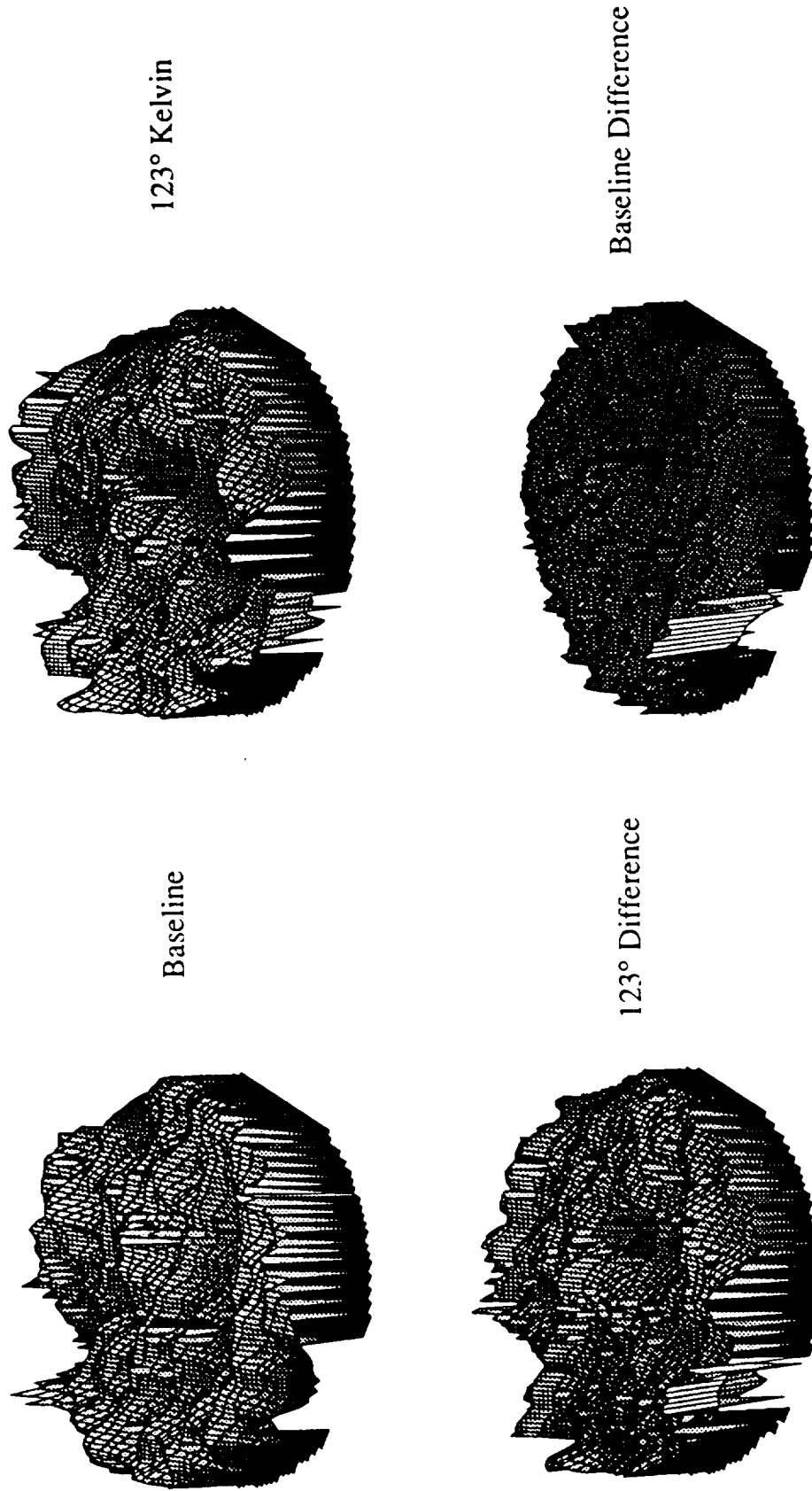

FIGURE 3: SURFACE PROFILES OF TEST OPTIC

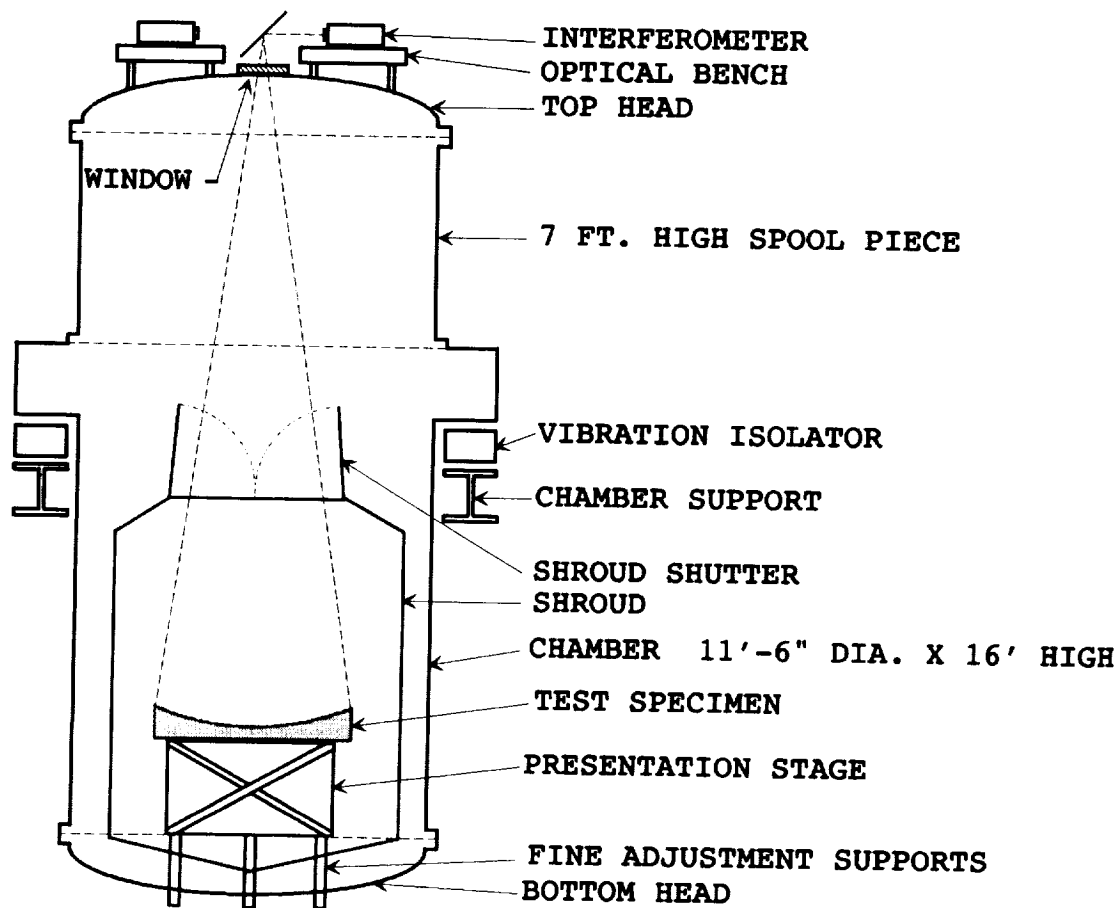

FIGURE 4: CROSS SECTIONAL VIEW OF VACUUM CHAMBER



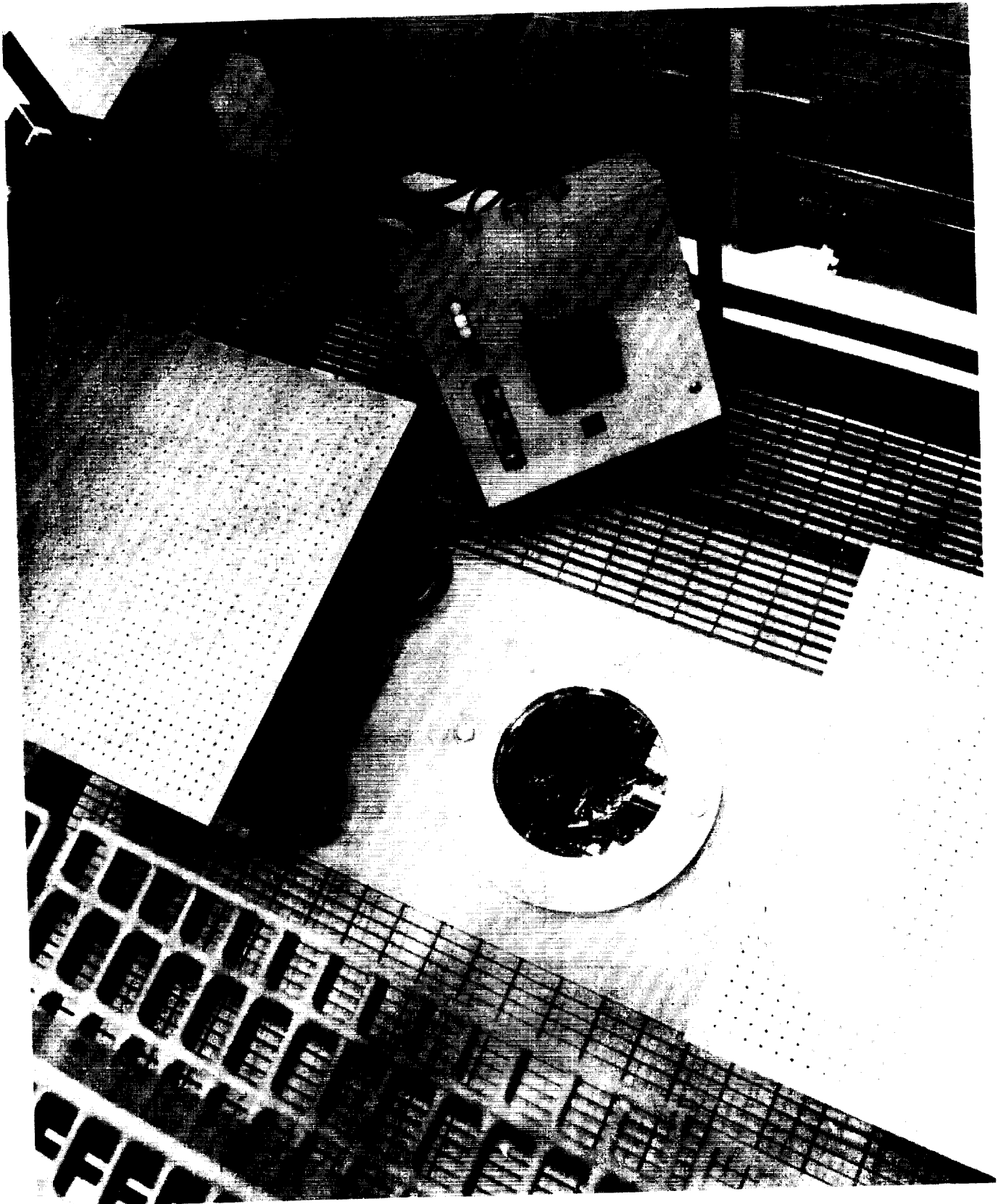

FIGURE 5: VIEWPORT AND OPTICAL BENCHES

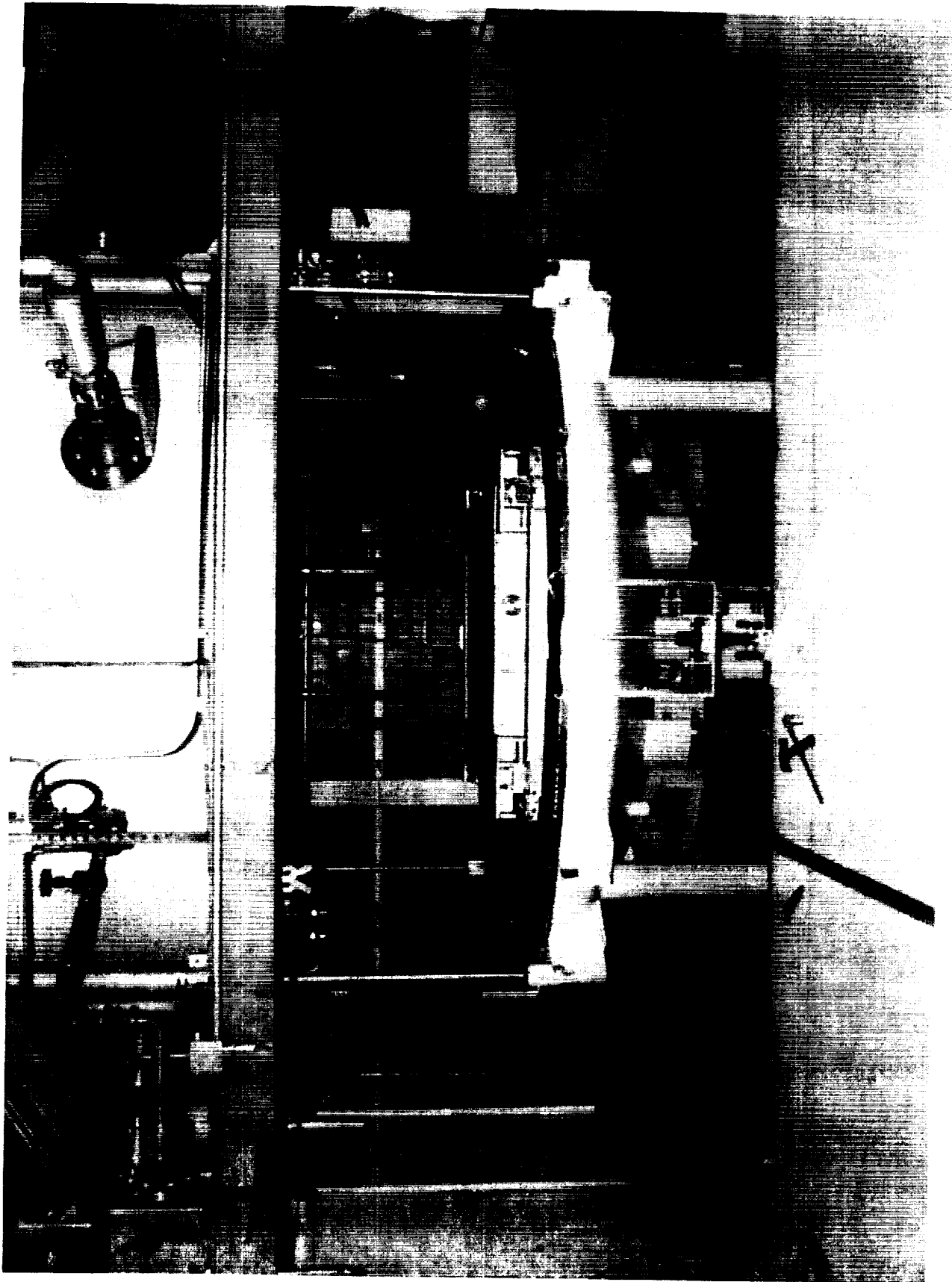

FIGURE 6: LOWERING BOTTOM HEAD INTO PIT

ORIGINAL PAGE  
BLACK AND WHITE PHOTOGRAPH

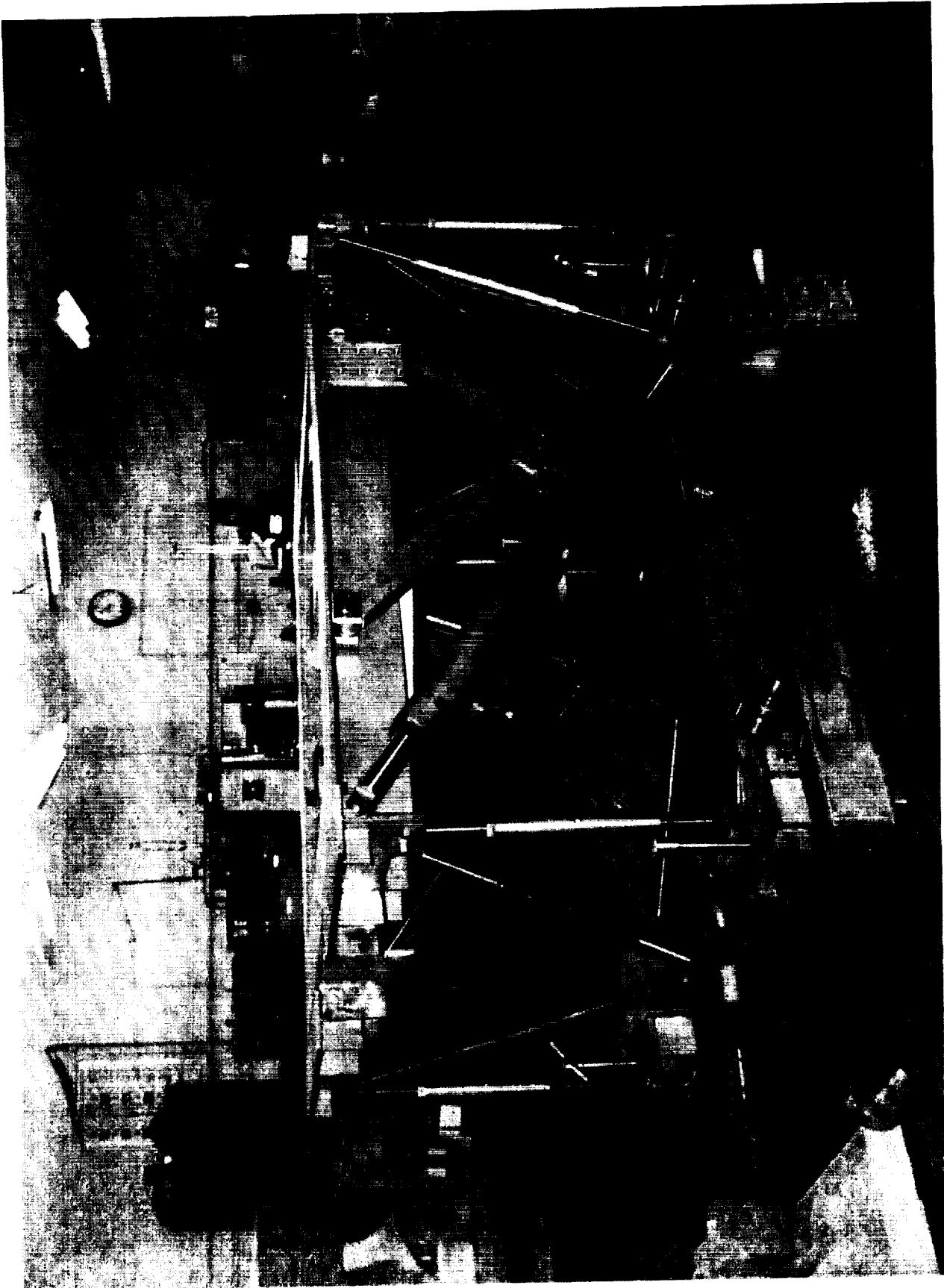

FIGURE 7: PRESENTATION STAGE

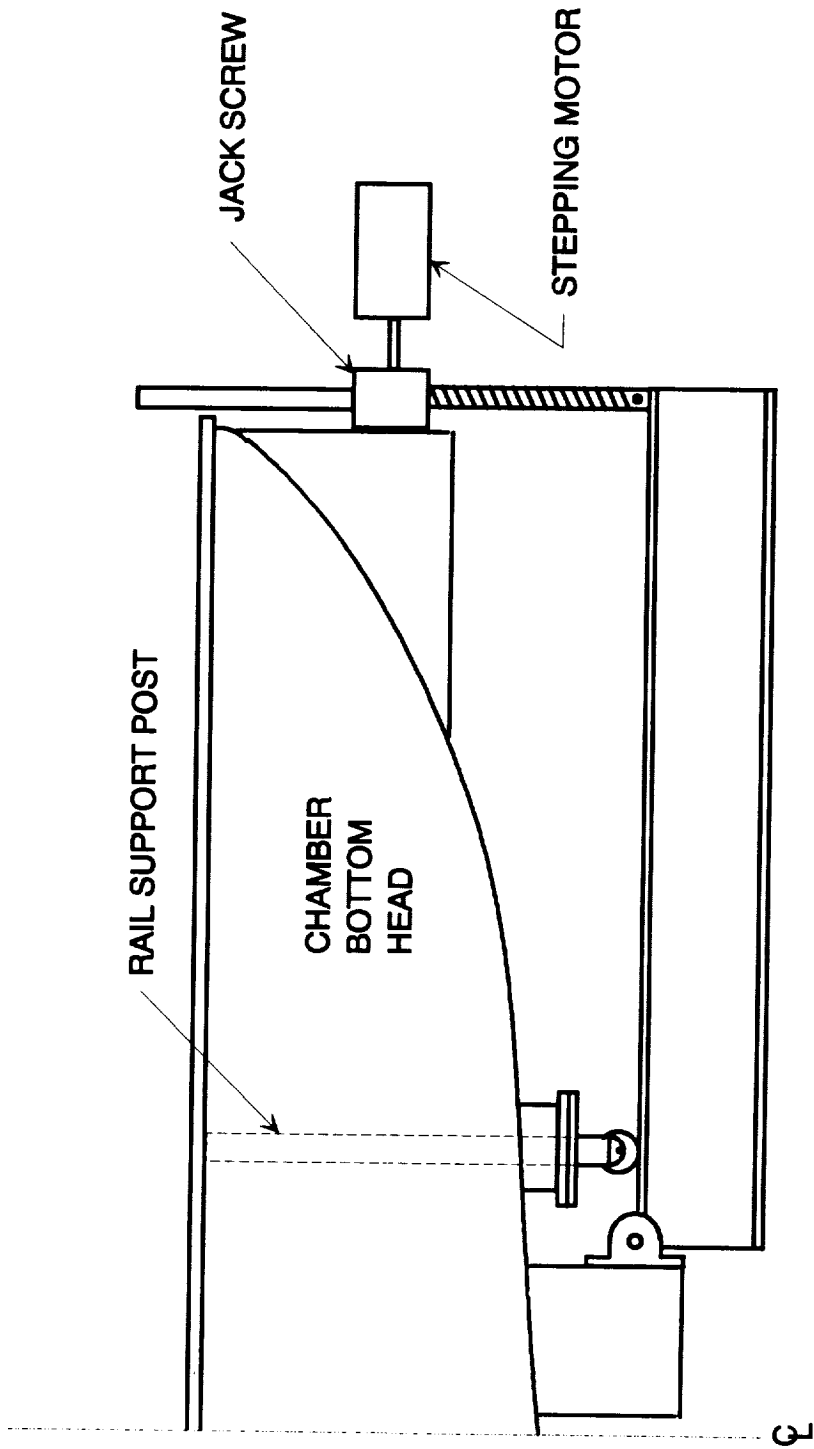

FIGURE 8: FINE ELEVATION ADJUSTMENT MECHANISM