

N91-22145

The Liquid Annular Reactor System (LARS) Propulsion

James Powell, Hans Ludewig, Frederick Horn
Brookhaven National Laboratory
Upton, New York
Roger Lenard, SDIO
The Pentagon, Washington, D.C.

A new concept for very high specific impulse (>2000 seconds) direct nuclear propulsion is described. The concept, termed LARS (Liquid Annular Reactor System) uses liquid nuclear fuel elements to heat hydrogen propellant to very high temperatures ($\sim 6000\text{K}$). Operating pressure is moderate (~ 10 atm), with the result that the outlet hydrogen is virtually 100% dissociated to monatomic H. The molten fuel is contained in a solid container of its own material, which is rotated to stabilize the liquid layer by centripetal force. LARS reactor designs are described, together with neutronic and thermal-hydraulic analyses. Power levels are on the order of 200 megawatts. Typically, LARS designs use 7 rotating fuel elements, are beryllium moderated and have critical radii of ~ 100 cm (core $L/D \approx 1.5$).

INTRODUCTION

As illustrated in Figures 1 and 2, the LARS fuel element consists of a rotating cylindrical can that holds an inner annular layer of a high temperature refractory material. This refractory contains uranium and an appropriate diluent(s), possibly a mixture of UC_2 and ZrC . The thin outer layer of the refractory, i.e., the portion adjacent to the fuel element can is solid, while the inner layer, i.e., the portion adjacent to the central channel where the hydrogen propellant flows, is liquid. Heat is generated in the refractory by fissioning of uranium. The bulk of this heat is transported by convective mixing in the annular liquid layer to the inner boundary between the flowing hydrogen propellant and the liquid. Here, heat flows into a seeded (e.g. with micron size tungsten particles) hydrogen propellant by a combination of radiant and convective transfer. Heat transfer rates to the propellant is very high, typically on the order of 5-10 kilowatts per cm^2 of surface area.

The liquid refractory is maintained as an annular layer by rotating the fuel element can at a speed sufficient to stabilize the molten fuel layer. The can is metal (beryllium) and is kept cool by heat transfer to the hydrogen propellant. The thermal conduction rate to the can from the fuel layer is relatively small, on the order of 100 watts per cm^2 .

Research carried out under the auspices of the U.S. Department of Energy under contract No. DE-AC02-76CH00016.

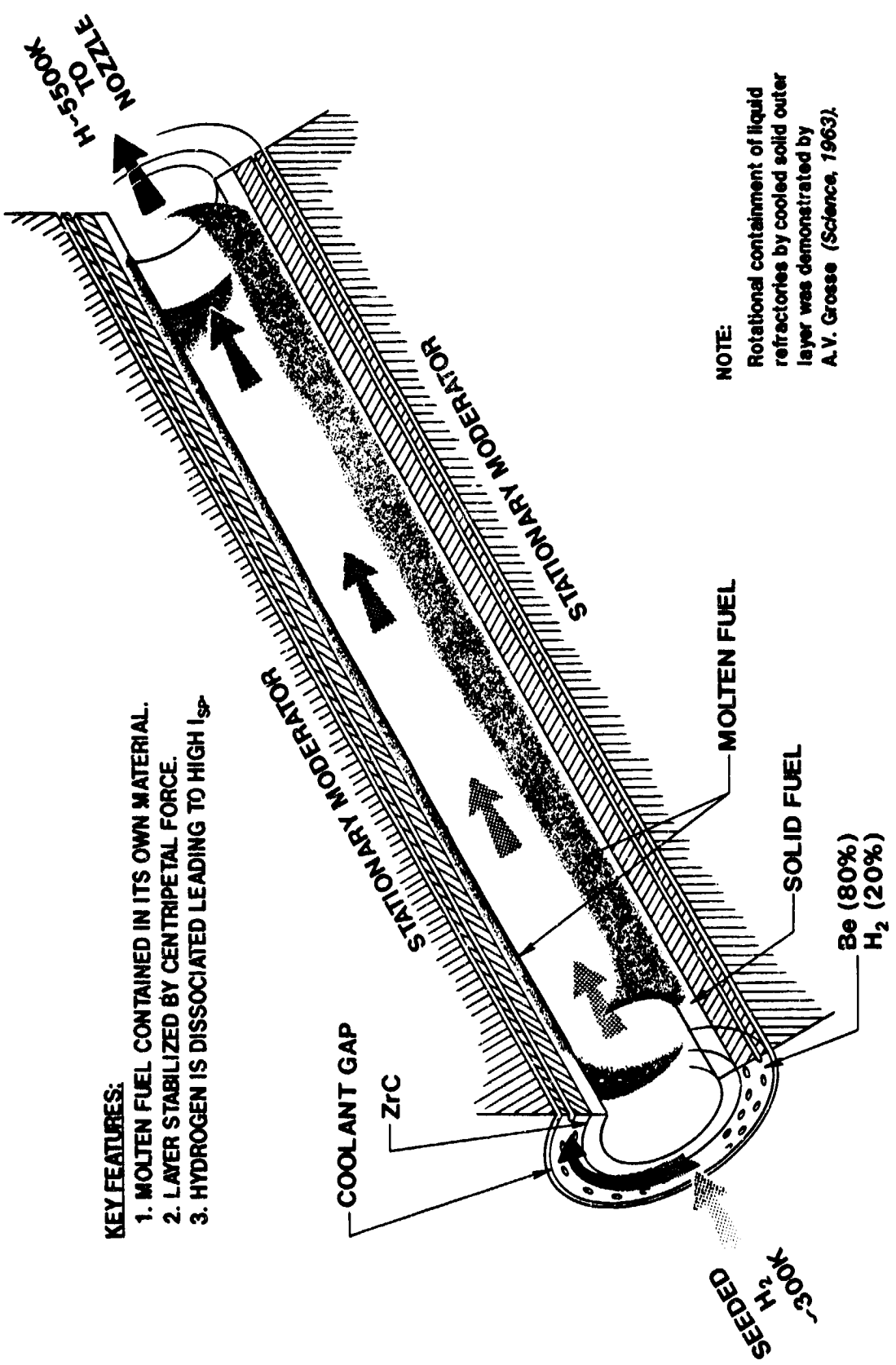

KEY FEATURES:

1. MOLTEN FUEL CONTAINED IN ITS OWN MATERIAL.
2. LAYER STABILIZED BY CENTRIFUGAL FORCE.
3. HYDROGEN IS DISSOCIATED LEADING TO HIGH I_{sp}

NOTE:

Rotational containment of liquid refractories by cooled solid outer layer was demonstrated by A.V. Grosse (Science, 1963).

Figure 1 LARS concept.

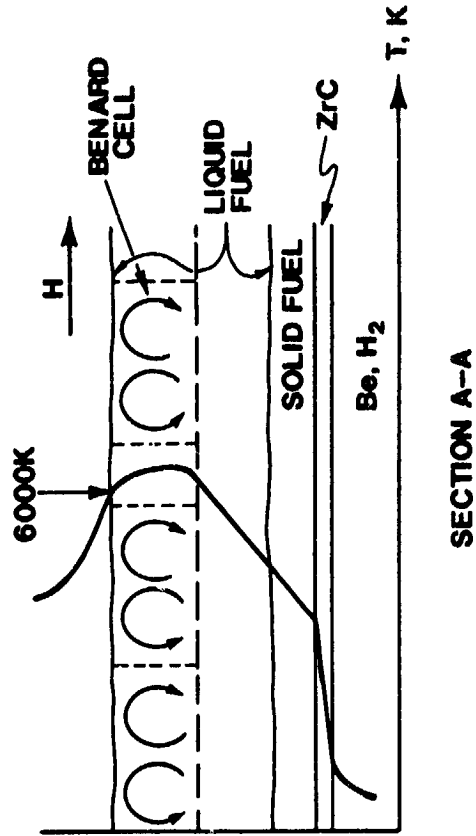
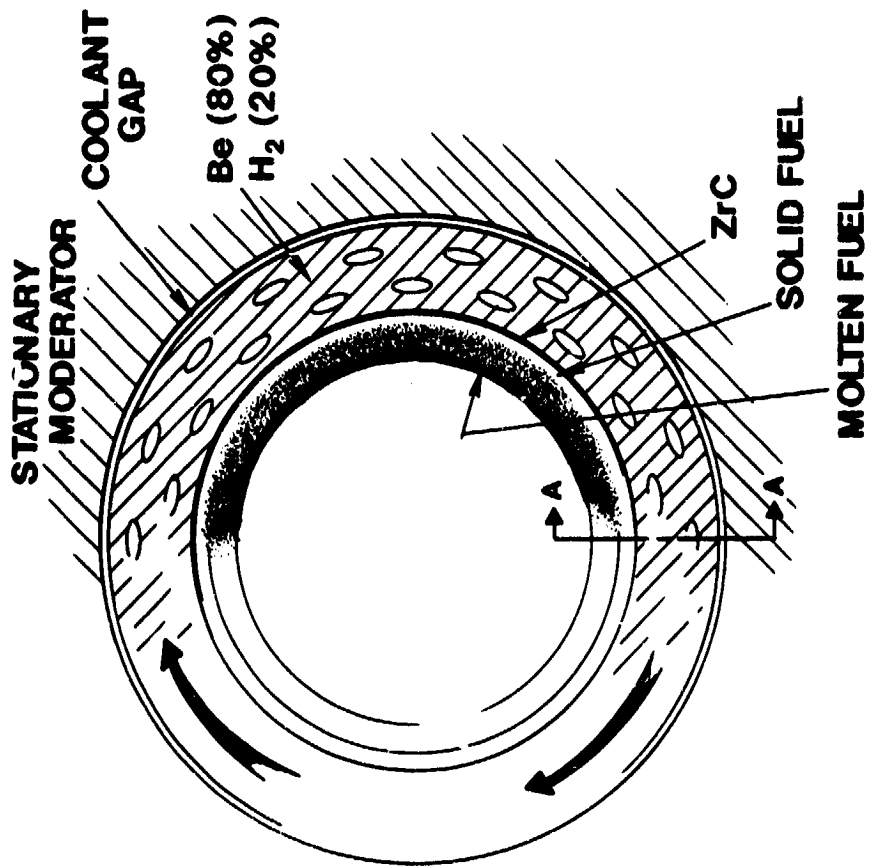

Figure 2 LARS rotating fuel element.

Rotational containment of high temperature liquid refractories by creation of a cooled solid outer layer was first demonstrated by A.V. Grosse (ref. 1). Containment of liquid refractories in cooled metal containers is also found in the vacuum arc melting industry, though here the containers are not rotated.

CONCEPTUAL REACTOR DESIGN

The reactor design is controlled by heat transfer and physics considerations. For a given total power (P) output, the radiant heating of the propellant must be sufficiently efficient to extract the heat at the desired flow rate. Convective heat transfer is, of course, also present, however, for the conditions of LARS, it is an order of magnitude smaller than the radiation. The efficiency of the radiation heat transfer process is controlled primarily by the emissivity of the molten fuel surface and the absorptivity of the gas volume. This efficiency will be represented by a multiplicative parameter (f) which can be varied over a reasonable range. Thus, in order to estimate the required heat transfer area and thus the outlet duct size, the radiant heat flux (Q) will be estimated from

$$Q = f \sigma T^4 \quad (1)$$

where T is the surface temperature.

The factor f is the amount of heat transferred by radiation from the liquid surface to the seed particles divided by blackbody radiation at the same temperature to a perfectly absorbing gas. If we assume that the liquid surface is "gray", f can be expressed as (Ref. 2):

$$f = \frac{\epsilon F_{wa}}{1 - \rho F_{ww}} \quad (2)$$

where ϵ is the emissivity of the surface, ρ its reflectivity and F_{wa} and F_{ww} are the view factors from surface to wall and wall to wall, respectively. Calculated values of the latter for a range of geometries are presented in Reference 2.

Considering reasonable absorption parameters of particle-seeded gases (Ref. 3) and the observed emissivities of molten refractories, it was concluded that a practical range of f is from 0.4 to 0.8. Consequently, the radiative surface heat flux was calculated for these values of f and a temperature range of 3000 to 6000K. These results are shown in Figure 3.

One can calculate the dimensions of the reactor if one assumes that the duct radius and height are related by a multiplicative constant (n). Thus, the duct area (A), for N fuel elements is given by

$$A = 2\pi N nr^2 \quad (3)$$

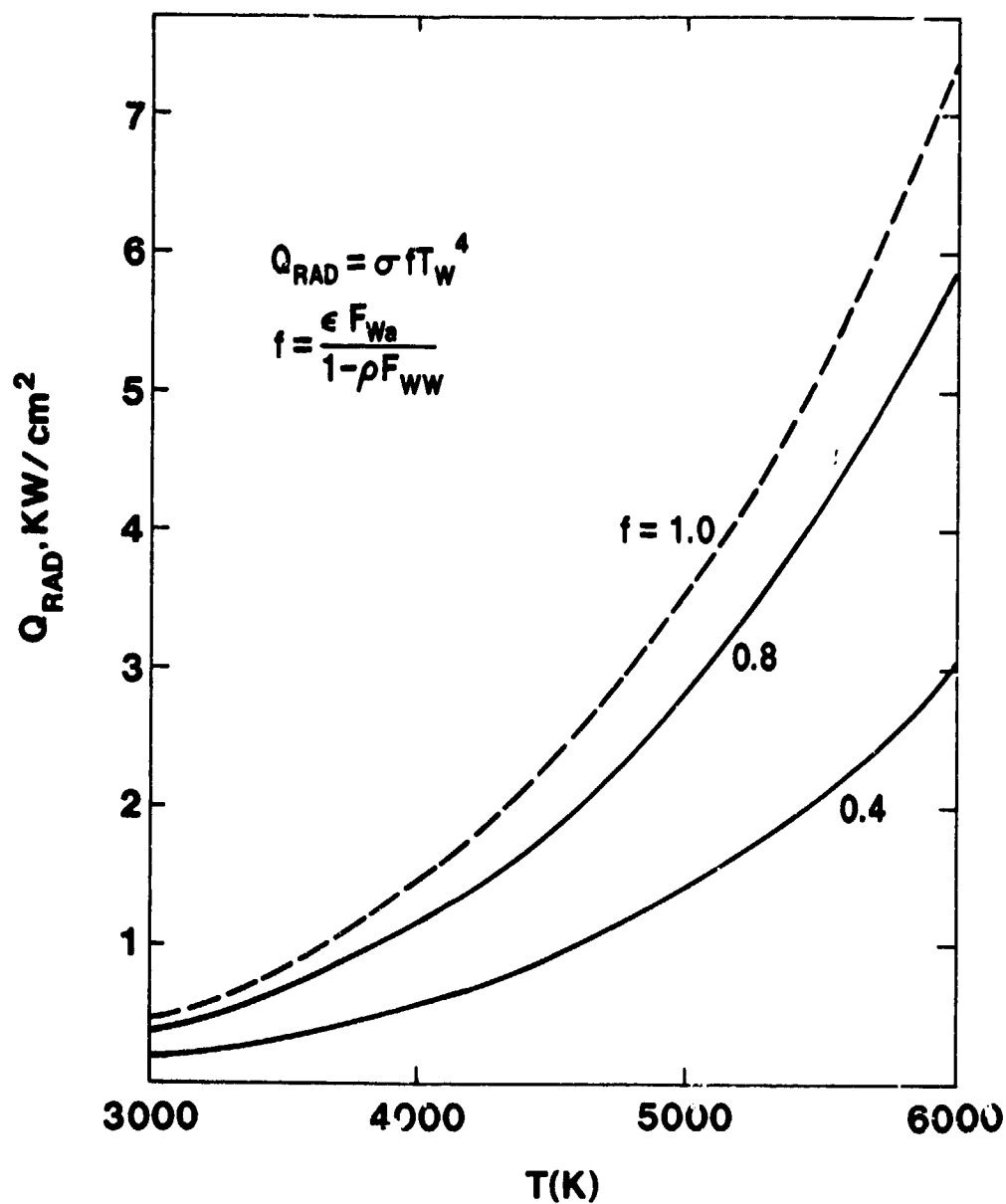

NOTE:

- ϵ = emissivity of liquid wall
- ρ = reflectivity of liquid
- F_{wa} = view factor wall to aerosol (Fig. 2 NASA CR-953)
- F_{ww} = view factor wall to wall (Fig. 3 NASA CR-953)

Figure 3 Radiative heat transfer from liquid surface to hydrogen.

and the required duct radius for a given P and Q can be calculated as

$$r = \left[\frac{P}{Q 2\pi nN} \right]^{1/2} \quad (4)$$

Based on the above relationships and assumptions, it is possible to investigate the variation of r with T for various values of f. In all cases, it will be assumed that $n = 24$, $N = 7$ and $P = 200$ MW. The implied outlet duct radii are shown on Figure 4. It can be seen that they range from a maximum of 32 cm for the lower temperature, to a minimum of 5.65 cm for the highest temperatures. The implied reactor height (given by $n = 24$) varies from 768 cm for the lowest temperature to 135.6 cm for the highest values of temperature and f values. In order to completely describe the reactor, an assumption must be made regarding the ratio between the outside fuel bed diameter and the fuel element pitch. The appropriate value for the pitch/diameter (P/D) ratio is a function of the moderator and its magnitude is chosen based on experience. Finally, a reflector thickness and a cooling duct geometry within the moderator and reflector must be assumed.

The above information describes the reactor system in sufficient detail in order that an estimate of its multiplication factor (K_{eff}) can be made. Due to the extreme heterogeneous nature and the high neutron leakage, these reactors can only be analyzed using an explicit geometrical representation of the core. These analyses were carried out using the MCNP Monte Carlo code. Two reactors, both operating as $T = 6000$ K but having f values of 0.4 and 0.8, respectively, were considered. Detailed dimensions and uranium carbide masses for these two systems are shown on Table I. Some of these dimensions are also illustrated in Figure 5. From Figure 4, it can be seen that if the value for f is allowed to vary from 0.4 to 0.8 (dashed line), a family of reactors is defined for which $Q = 3.0$ kw/cm² and whose temperature varies from 6000K to 5150K. In other words, any improvement in the effectiveness of radiative heat transfer f, permits operation at a lower surface temperature. All these reactors are critical and have the same geometrical dimensions. A larger family of reactors can be defined by the shaded area in Figure 4. These should all be critical and operate at various values of temperature T and heat transfer parameter f, i.e. $5150 \leq T \leq 6000$ K and $.4 \leq f \leq 0.8$. Although larger reactors operating at lower temperatures are possible, these begin to lose the unique advantages of the LARS concept.

TECHNICAL ISSUES

The major technical issues that must be addressed in the design of LARS are the following:

1. Stability of liquid layer
 - a. Effects of rocket acceleration
 - b. Helmholtz instability
 - c. Convective cells (Bénard Problem)

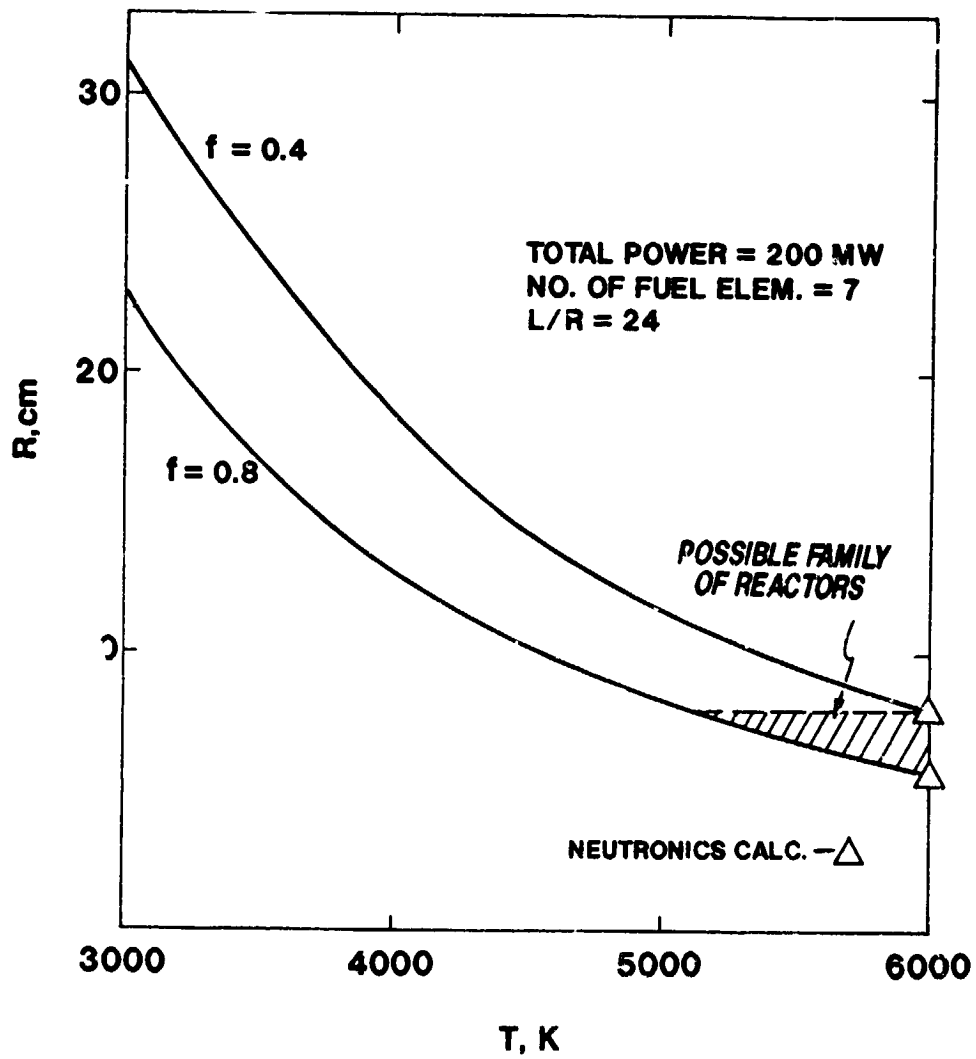

Figure 4 Flow channel radius vs. temperature

TABLE I. REACTOR PARAMETERS

| | $f = 0.4$ | $f = 0.8$ |
|----------------------------------|-----------|-----------|
| TOTAL POWER (MW) | 200. | 200. |
| OUTLET TEMPERATURE (K) | 6000. | 6000. |
| OUTLET PRESSURE (ATM) | 10. | 10. |
| NO. OF ELEMENTS | 7 | 7 |
| OUTLET DUCT RADIUS (CM) | 8.0 | 5.6 |
| FUEL BED RADIUS (CM) | 9.4 | 8.1 |
| ROTATING DRUM RADIUS (CM) | 12.4 | 11.1 |
| ELEMENT PITCH (CM) | 30.0 | 30.0 |
| REACTOR O.D. (CM) | 110.0 | 110.0 |
| REACTOR HEIGHT (CM) | 192.7 | 135.5 |
| TOP REFLECTOR (CM) | 3.0 | 3.0 |
| BOTTOM REFLECTOR (CM) | 5.0 | 5.0 |
| RADIAL REFLECTOR (CM) | 10.0 | 10.0 |
| MASS OF UC_2 (KG) | 30.0 | 30.0 |
| MULTIPLICATION FACTOR, K_{eff} | 1.08 | 1.10 |

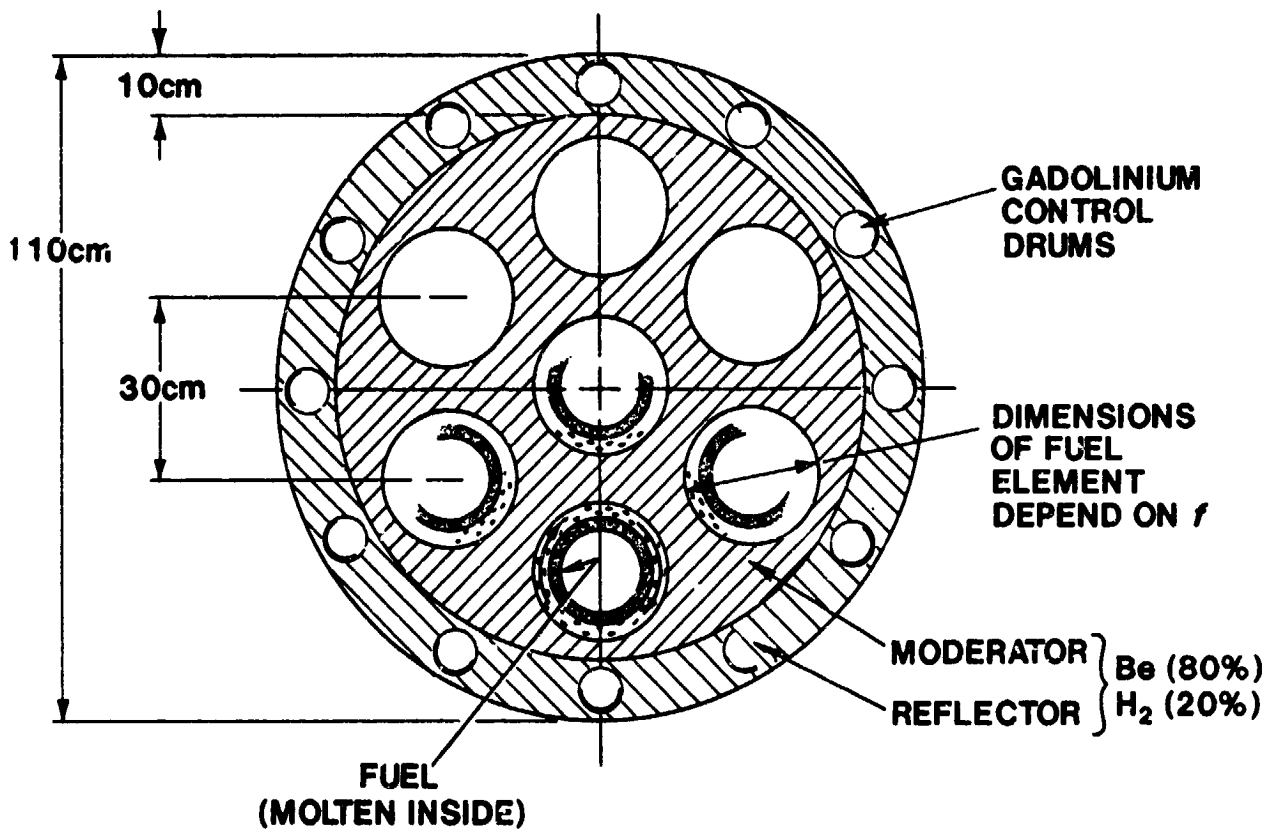

Figure 5 LARS design cross section.

2. Heat Transfer
 - a. Combined radiation and convection
 - b. Seeding of H_2 to increase radiation
 - c. Moderator cooling
 - d. Nozzle cooling
3. Physics
 - a. High temperature cross sections
 - b. Heterogeneous core - will require critical experiment
 - c. Reactor startup
4. Materials
 - a. Radiative properties of liquid fuel
 - b. Compatibility with H_2
 - c. Evaporative loss of fuel
 - d. Resistance to radiation damage

CONCLUSIONS

1. The LARS molten core concept permits operation with hydrogen coolant at high enough temperatures to dissociate.
2. Specific impulse can be doubled relative to "conventional" nuclear rockets.
3. Development of LARS allows high ΔV missions (outer planets, fast trip times, etc.) using low weight, high thrust, high I_p propulsion.

REFERENCES

1. Grosse, A.V., "High-Temperature Research", *Science*, 140, 781-789 (1963).
2. Keng, E.Y.H. and Orr, Clyde, Jr., "Investigation of Radiant Heat Transfer to Particle-Seeded Gases for Application to Nuclear Rocket Engine Design", NASA CR-953 (1967).
3. Williams, J.R., et al, "Thermal Radiation Absorption by Particle-Seeded Gases", *J. Spacecraft*, 8, 339-346 (1971).