

58-18

N91-22339

7551

P. 9

# Vibration Suppression and Slewing Control of a Flexible Structure

Daniel J. Inman<sup>†</sup>  
Ephrahim Garcia<sup>††</sup>  
Brett Pokines<sup>†††</sup>

Department of Mechanical & Aerospace Engineering  
University at Buffalo  
Buffalo, NY 14260

## Abstract

This work examines the effects of motor dynamics and secondary piezoceramic actuators on vibration suppression during the slewing of flexible structures. The approach focuses on the interaction between the structure, the actuators and the choice of control law. The results presented here are all simulated but are based on experimentally determined parameters for the motor, structure, piezoceramics actuators and piezofilm sensors. The simulation results clearly illustrate that the choice of motor inertia relative to beam inertia make a critical difference in the performance of the system. In addition the use of secondary piezoelectric actuators reduces the load requirements on the motor and also reduces the overshoot of the tip deflection.

The structures considered here are a beam and a frame. The majority of the results are based on an Euler Bernoulli beam model. The slewing frame introduces substantial torsional modes and a more realistic model. The slewing frame results are incomplete and represent work in progress.

## 1. Introduction

A slewing motion consists of the rotation of a structure about a point. In the case considered here, a DC electric motor is used to move a beam and/or a frame about the axis of the motor in order to orient the length of the structure in a new direction (see figure 1). In the past, slewing maneuvers have been carried out on passive structures, i.e., structures which have no internal control or sensing mechanisms. Here, the effects of slewing an active structure are considered. An active or smart structure is defined as a structure with sensors and actuators integrated within the structure (Wada, 1989). A passive structure does not contain any integrated control hardware. The slewing of a passive beam has been considered by several researchers. Garcia (1989) and Garcia and Inman (1990) examine the dynamic interaction between the structure and actuator in slewing a passive beam. Juang et al (1986), Yurkovich and Tzes (1990), Cannon and Schmitz (1984) and Hastings and Book (1987) have all consider the effects of slewing passive beams. Park et al (1989) considered slewing a passive beam with a secondary voice coil actuator attached to improve vibration suppression. Their results motivated the work presented here which considers the effects of slewing an active beam. This presents a multiple input control problem. The active beam consists of a flexible aluminum beam with embedded piezoelectric actuators and sensors. The results for the active beam have been presented in preliminary form at the Army Research

<sup>†</sup> Professor and Chair  
<sup>††</sup> Visiting Assistant Professor  
<sup>†††</sup> Graduate Student

663



Office Workshop (see Inman et al 1990). The slewing frame example is experimental and represents work in progress.

The analysis proceeds by forming a Hamiltonian consisting of the elastic and kinetic energy in the Euler-Bernoulli beam, plus the nonconservative work done on the beam by the DC motor and piezoceramic actuator. Garcia (1989) illustrated that the dynamic interaction between the slewing actuator, the DC motor, and the flexible structure can lead to improved vibration suppression. Traditionally, the slewing control of a flexible single link structure has been a single actuator problem. Park et al (1989) proposed the use of a "voice-coil" actuator in addition to the slewing motor; this actuator was rigidly attached to the slewing hub and actuated the beam near the clamped end. This approach achieved improved structural dynamic performance and reduced peak motor voltages. However, these performance gains were at the cost of adding the mass of the coil actuator and its supporting mechanical fixture to the slewing payload.

We propose that direct structural actuation be achieved in the slewing maneuver by use of a piezoceramic actuator. This active structure will contain a layered piece-wise distributed, or segmented, piezoceramic crystal in the case of the beam and an active longeron element consisting of bending piezoceramics for the frame. The active beam being considered here is similar to those considered earlier in a damped configuration by Fanson and Caughey (1987) and Burke and Hubbard (1987). Fanson and Caughey considered a cantilevered flexible beam controlled by a collocated pair of piezoelectric actuators and strain sensors coupled with a positive position feedback control law. In the case presented here a piezofilm will be used instead of a piezoceramic for the strain measurement and piezoceramics are used for actuators.

A theoretical optimal control study is performed using a linear quadratic regulator (LQR) control formulation. This is presented only for the beam. A comparison of control laws is made where the penalty function is varied to change the degree of control effort afforded by the active beam. The goal here is to illustrate that increased vibration suppression may occur in slewing maneuvers by taking advantage of control structure interaction and to investigate the vibration suppression effects of slewing an active structure.

## 2. System Dynamics

The dynamics of the slewing beam system are developed from Hamilton's principle. First, the dynamics of a slewing piezo-actuated structure are considered with the effects of a piece-wise distributed piezo actuator. The actuator dynamics, that is, the interaction of motor and beam are also modeled. The moment generated by the piece-wise distributed, piezo actuator is calculated. Finally, the equations of motion for this active slewing structure are assembled in a lumped mass model representation. The details can be found in Inman et al (1990) and follows directly from Garcia (1989).

Figure 1 illustrates the coordinates used in defining the equations of motion of a flexible structure undergoing a slewing motion through an angle  $\theta(t)$ . The deflection of the beam  $y(x,t)$  is defined relative to the rigid motions  $\theta$ . The torque causing the motion is denoted by  $\tau$ . The beam, of length  $L$ , deforms and rotates in the X-Y plane. Figure 2 illustrates the model of the motor. Figure 3 illustrates the use of piezoceramics in the slewing beam.

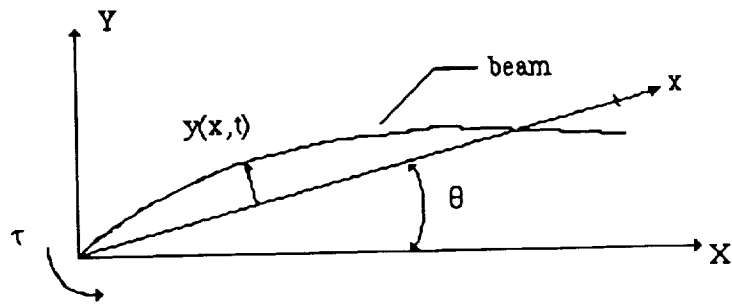

Fig. 1. Slewing flexible beam schematic.

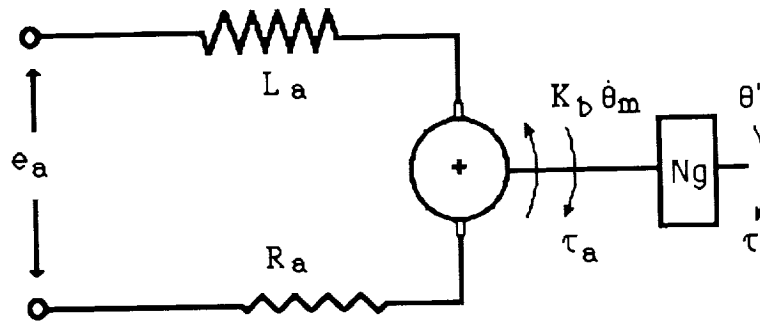

Fig. 2. Motor armature circuit and gear box schematic.

EDGE VIEW

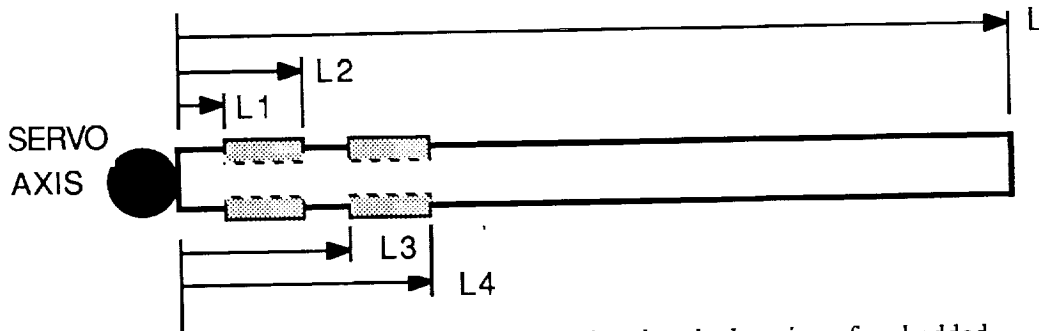

Fig. 3. Schematic of the slewing beam showing the location of embedded piezoceramic actuators.

### 3. Control Design

A linear quadratic regulator control law was designed to illustrate the effects of slewing an active structure versus slewing a passive structure. The results are based on a beam/motor system designed to take maximum advantage of the interaction between the structural modes and the motor torque. Both the voltages to the electric motor and to the embedded piezoceramic were used as control inputs.

To perform the control analysis, the mathematical model presented in Inman et al (1990) is discretized in space and manipulated into state space form. Combining the governing equations and assuming that only  $n$  terms are used in a modal approximation (5), the equations of motion of the slewing active structure can be written in matrix form as the vector differential equation

$$\mathbf{M}\ddot{\mathbf{q}} + \mathbf{D}\dot{\mathbf{q}} + \mathbf{K}\mathbf{q} = \mathbf{B}_f \mathbf{u} \quad (1)$$

where the vector  $\mathbf{q}$  is defined by  $\mathbf{q}^T = [\theta(t) \ q_1(t) \ q_2(t) \ \dots \ q_n(t)]$ . The mass, damping and stiffness coefficient matrices are:

$$\mathbf{M} = \begin{bmatrix} I_b + I_s & I_1 + I_s \Gamma_1(0) & \dots & I_n + I_s \Gamma_n(0) \\ I_1 + I_s \Gamma_1(0) & M_1 & & \vdots \\ \vdots & & & \vdots \\ I_n + I_s \Gamma_n(0) & \dots & & M_n \end{bmatrix} \quad (2)$$

$$\mathbf{D} = \begin{bmatrix} b_v & b_v \Gamma_1(0) & \dots & b_v \Gamma_n(0) \\ b_v \Gamma_1(0) & b_v \Gamma_1(0)^2 & \dots & b_v \Gamma_1(0) \Gamma_n(0) \\ \vdots & & & \vdots \\ b_v \Gamma_n(0) & b_v \Gamma_n(0) \Gamma_1(0) & \dots & b_v \Gamma_n(0)^2 \end{bmatrix} \quad (3)$$

$$\mathbf{K} = \begin{bmatrix} 0 & & \mathbf{0}_{1 \times n} \\ & M_1 \omega_1^2 & \vdots \\ \mathbf{0}_{n \times 1} & \dots & \vdots \\ & & & M_n \omega_n^2 \end{bmatrix} \quad (4)$$

where  $\Gamma_i = \phi_i'(0)$ , the  $i$ th modal participation factor. In addition,  $M_i$  is the  $i$ th modal mass,  $\omega_i$  denotes the structures natural frequencies and the  $i$ th inertia term is given by

$$I_i = \int_0^L \rho x \phi_i(x) dx$$

The control input vector  $\mathbf{u}$  is the  $2 \times 1$  vector  $\mathbf{u}^T = [e_a, V_p]$  and the control coefficient matrix is

$$\mathbf{B}_f^T = \begin{bmatrix} \frac{N_g K_t}{R_a} & \frac{N_g K_t}{R_a} \Gamma_1 & \dots & \frac{N_g K_t}{R_a} \Gamma_n \\ 0 & \mu[\phi_1'(L_1) - \phi_1'(L_2)] & \dots & \mu[\phi_n'(L_1) - \phi_n'(L_2)] \end{bmatrix} \quad (5)$$

for a single segment piezoceramic actuator.

Active control is performed by using state feedback and solving a standard linear quadratic regulator (LQR) control law design. The system of Eq. (1) is first put into state space form by defining the state vector  $\mathbf{x}$  as

$$\mathbf{x} = \begin{bmatrix} \mathbf{q} \\ \dot{\mathbf{q}} \end{bmatrix} \quad (6)$$

and the corresponding state matrix

$$\mathbf{A} = \begin{bmatrix} 0 & \mathbf{I} \\ -\mathbf{M}^{-1}\mathbf{K} & -\mathbf{M}^{-1}\mathbf{C} \end{bmatrix} \quad (7)$$

where 0 denotes the matrix of zeros and I denotes the identity matrix of appropriate dimension. With this change of coordinates, Eq. (1) becomes

$$\dot{\mathbf{x}} = \mathbf{A}\mathbf{x} + \mathbf{B}\mathbf{u} \quad (8)$$

with output measurements defined by

$$\mathbf{y} = \mathbf{C}\mathbf{x} \quad (9)$$

Here the matrix of constants C specifies which coordinates of the vector  $\mathbf{x}$  are measured. State feedback control is implemented by specifying the relation

$$\mathbf{u} = -\mathbf{K}_f\mathbf{x} \quad (10)$$

The LQR control algorithm then calculates the value of the gain matrix  $\mathbf{K}_f$  such the cost functional

$$J = \int_0^{\infty} (\mathbf{x}^T\mathbf{Q}\mathbf{x} + \mathbf{u}^T\mathbf{R}\mathbf{u})dt \quad (11)$$

is minimized. The matrices Q and R are symmetric positive definite weighting matrices which are chosen to produce acceptable responses. In the case presented here the matrix Q was chosen to be

$$\mathbf{Q} = \text{diag} [ 8 \ 3 \ 1 \ 1 \ 8 \ 3 \ 1 \ 1 ] \quad (12)$$

which places emphasis on minimizing the angular displacement (and velocity) and the first modal displacement (and velocity). The control law determined from this weighting attempts to drive the angular position and structure displacement to zero. The weighting matrix R is chosen to have two different values to generate a control law with vibration suppression both with and without the use of the piezoceramic actuator. For the case with the added piezo actuator, the matrix R is chosen to be

$$\mathbf{R}_1 = \text{diag} [ 1.0 \ 1 \times 10^{-4} ] \quad (13)$$

This choice penalizes the use of the motor voltage in favor of the piezoelectric actuator voltage. For the case without piezo actuator control, the weighting matrix R is chosen to be

$$R_2 = \text{diag} [ 1.0 \quad 1 \times 10^8 ] \quad (14)$$

A comparison of the results of using the piezoceramic actuator versus using only the motor torque for vibration suppression of the beam is illustrated in figures 5-8. In each case the control or response without the advantage of the piezoceramic is given by the dashed line and those with the use of the active beam are given by the solid lines. Figure 5 illustrates that the voltage supplied to the armature of the motor is reduced by 33% (from -3 volts to -2 volts) when slewing is performed on an active beam versus a passive beam. Figure 7 clearly illustrates that the maximum tip deflection (overshoot) is reduced by almost 50% by using the piezoceramic actuator.

#### 4. Closing Remarks

This paper examines slewing control by introducing the concept of using an active structure to improve performance. Slewing an active structure, as opposed to slewing a passive structure, offers the advantage of reducing the peak voltage demands on the slewing motor hence increasing reliability and potentially saving weight (a smaller motor could be used). In addition the active structure approach promises to substantially reduce maximum tip deflection of the structure. Simulation results were presented for a beam. These results, although simulated, use experimentally measured parameters from laboratory tests of the beam, motor and piezoceramics. The passive slewing beam model has been experimentally verified using a PID control (Garcia, 1989).

The frame experiment of figure 4 is in progress. The finite element model is developed and experimentally tested. The active strut has been designed and constructed and is being installed in the frame. The key experimental results of interest are the strong coupling between the bending vibration of the frame and the torsional vibration of the frame. While this is to be expected, the flexibility of the frame ( $\omega_1 = 1.6$  Hz) enhances the problem of suppressing tip vibration. Preliminary controllability calculations indicate that, unlike the beam, the secondary piezoelectric actuator is needed to produce large enough control effort to suppress the torsional modes.

In conclusion, the slewing of flexible structures requires a detailed examination of control structure interaction and can benefit from the use of "smart" structures. The result is best illustrated by examining the control input matrix  $B_f$  of equation (5). Without modeling the interaction and flexibility of the structure the matrix,  $B_f$  is a scalar (i.e.,  $\Gamma = 0$ ). When the interaction is modeled ( $\Gamma \neq 0$ ) the matrix  $B_f$  becomes a row vector. When the secondary piezoceramic actuators are added, the matrix  $B_f$  becomes  $2 \times n$  and the system is approaching full state feedback which is known to yield the best performance.

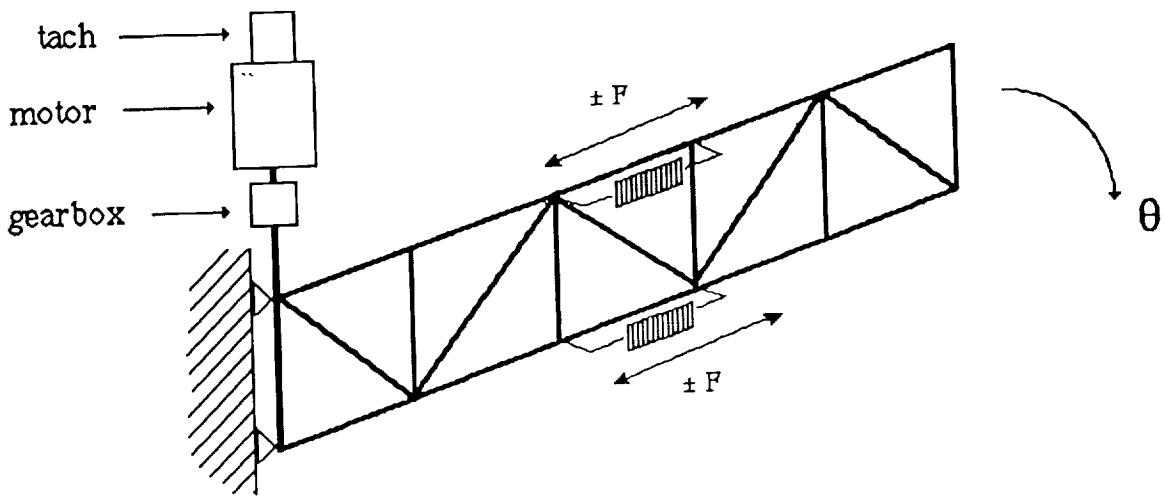

Fig. 4. The experimental slewing frame with active, piezoceramic struts in bending.

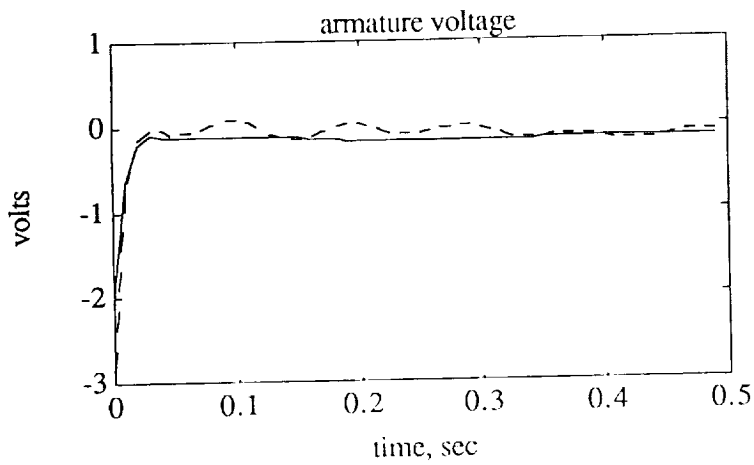

Fig. 5. Voltage applied to the armature of the motor for each of the two control laws.

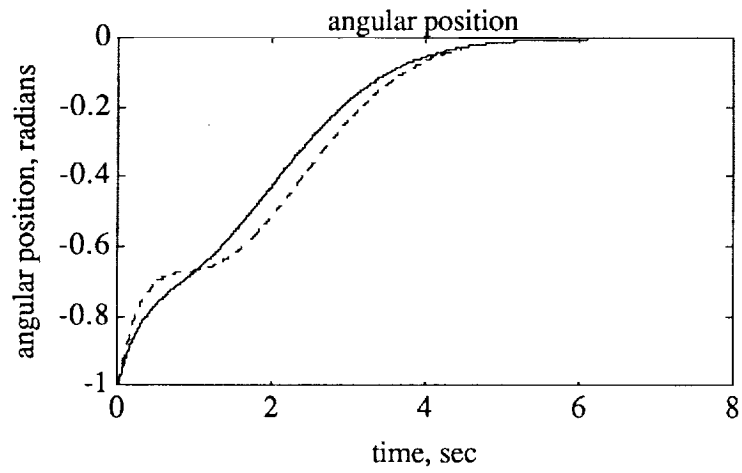

Fig. 6. Angular position versus time for each of the two control laws.

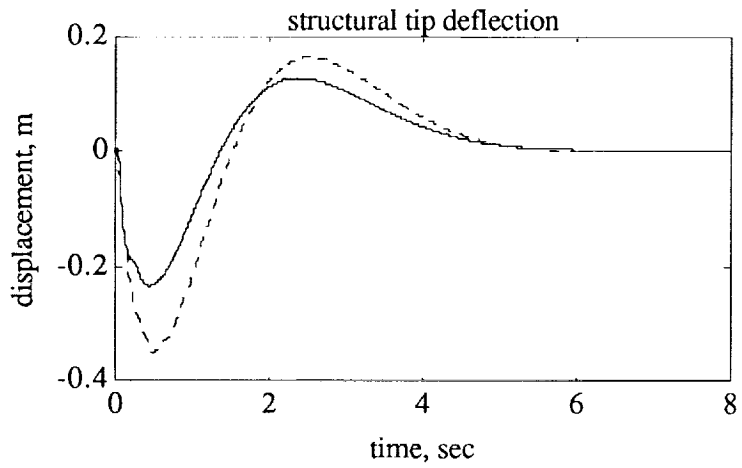

Fig. 7. The deflection of the tip of the beam versus time for each of the two control laws.



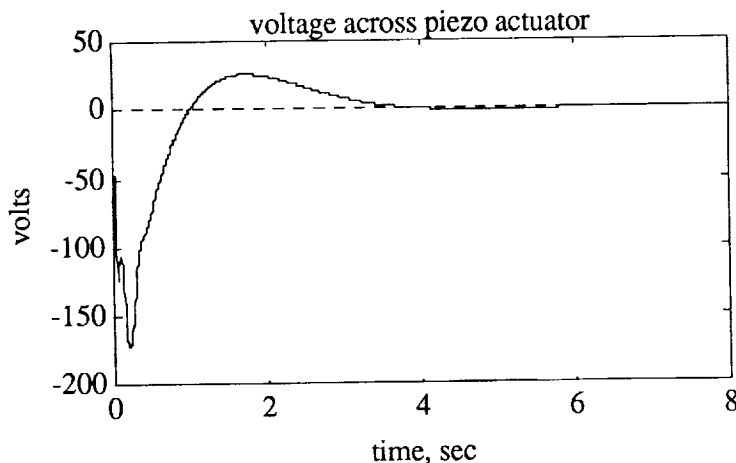

Fig. 8. The voltage applied to the piezoceramic versus time for each of the two control laws.

## References

- Burke S. B., and Hubbard J. E., 1987, "Active Vibration control of a Simply Supported Beam Using a Spatially Distributed Actuator" *IEEE Control Systems Magazine*, Vol. 7 No. 4.
- Cannon, H.C. Jr. and Schmitz, E., 1984, "Initial Experiments on the End-Point Control of a Flexible One-Link Robot," *International Journal of Robotics Research*, Vol. 3, No. 3, pp. 62-75.
- Crawley, E.F. and Anderson, E.H., 1990, "Detailed Models of Piezoceramic Actuation of Beams," *Journal of Intelligent Material Systems and Structures*, Vol. 1, pp. 4-25. Also AIAA paper number 89-1388 CP in the *Proceedings of 1989 AIAA Structure Dynamic and Materials Conference*, pp. 2000-2010.
- Fanson J. L. and Caughey T.K., 1987, "Positive Position Feedback Control for Large Space Structures," AIAA Paper No. 87-0902.
- Garcia, E., 1989, "On the Modeling and Control of Slewing Flexible Structures," Ph. D. Thesis, Department of Mechanical and Aerospace Engineering, State University of New York at Buffalo.
- Garcia, E., Inman, D.J., 1990, "Modeling Actuator-Structure Interaction in the Slewing of Flexible Structures," *Proceedings of the American Controls Conference*, San Diego, California, May 23-25, to appear.
- Hastings, G.G. and Book, W.J., 1987, "A Linear Dynamic Model for Flexible Robotic Manipulators," *IEEE Control Systems Magazine*, pp. 61-64.
- Inman, D.J., Garcia, E. and Pokines, B., 1990, "Issues in Slewing an Active Structure," *Proceedings U.S.-Japan Workshop on Smart/Intelligent Materials and Structures*, May 1990.
- Juang, J.N., Horta, L.G. and Robertshaw, H., 1986, "A Slewing Control Experiment for Flexible Structures," *AIAA Journal of Guidance, Control and Dynamics*, Vol. 9, No. 5, pp. 599-607.
- Park, Y.-P., Kim, S.-H., Ha, Y.-K., Park, H.-S., 1989, "Analysis and Test on the Digital Optimal Control of a Flexible Rotor Arm Vibration," *Proceeding of the 7th International Modal Analysis Conference*, pp. 1489-1495.
- Randall, D. S., and O'Neill, C. G., 1981, "Axial-mode Piezoelectrically-Driven Beam Deflectors" SPIE Vol. 299 *Advances In Laser Scanning Technology*.
- Wada, B.K., 1989 (ed), *Adaptive Structures*, Book No. AD-Vol. 5, ASME, New York, NY.
- Yurkovich, S. and Tzes, A., 1990, "Experiments in Identification and Control of Flexible-Link Manipulators," *IEEE Control Systems Magazine*, Vol. 10, No. 2.

