

AGARD

ADVISORY GROUP FOR AEROSPACE RESEARCH & DEVELOPMENT

7 RUE ANCELLE 92200 NEUILLY SUR SEINE FRANCE

AGARDograph 160
Flight Test Instrumentation Series - Volume 19

Digital Signal Conditioning for Flight Test

(Le Traitement du Signal Numérique
pour les Essais en Vol)

by

G.A. Bever
NASA, Ames Research Center
Moffett Field
California 94035
United States

This AGARDograph has been sponsored by the Flight Mechanics Panel of AGARD.



North Atlantic Treaty Organization
Organisation du Traité de l'Atlantique Nord

REPORT DOCUMENTATION PAGE

1. Recipient's Reference	2. Originator's Reference AGARD-AG-160 Volume 19	3. Further Reference ISBN 92-835-0621-9	4. Security Classification of Document UNCLASSIFIED										
5. Originator	Advisory Group for Aerospace Research and Development North Atlantic Treaty Organization 7 rue Ancelle, 92200 Neuilly sur Seine, France												
6. Title	DIGITAL SIGNAL CONDITIONING FOR FLIGHT TEST												
7. Presented at													
8. Author(s)/Editor(s) G.A. Bever	9. Date June 1991												
10. Author's/Editor's Address See Flyleaf	11. Pages 90												
12. Distribution Statement	This document is distributed in accordance with AGARD policies and regulations, which are outlined on the back covers of all AGARD publications.												
13. Keywords/Descriptors	<table border="0"> <tr> <td>Digital techniques</td> <td>Data buses</td> </tr> <tr> <td>Flight tests</td> <td>Digital filters</td> </tr> <tr> <td>Data transmission</td> <td>Aircraft</td> </tr> <tr> <td>Data processing</td> <td>Flight instruments</td> </tr> <tr> <td>Avionics</td> <td></td> </tr> </table>			Digital techniques	Data buses	Flight tests	Digital filters	Data transmission	Aircraft	Data processing	Flight instruments	Avionics	
Digital techniques	Data buses												
Flight tests	Digital filters												
Data transmission	Aircraft												
Data processing	Flight instruments												
Avionics													
14. Abstract	<p>This volume in the AGARD Flight Instrumentation Series provides flight test instrumentation engineers with an introduction to digital processes on aircraft. Flight test instrumentation systems are rapidly evolving from analog intensive to digital intensive systems, including the use of onboard digital computers. Topics include: measurements that are digital in origin, sampling, encoding, transmitting, and storing of data. Particular emphasis is placed on modern avionic data bus architectures and what to be aware of when extracting data from them. Some example data extraction techniques are given. Tradeoffs between digital logic families, trends in digital development, and design testing techniques are discussed. An introduction to digital filtering is also covered.</p> <p>This AGARDograph was sponsored by the Flight Mechanics Panel of AGARD.</p>												

<p>AGARDograph 160 Volume 19 Advisory Group for Aerospace Research and Development, NATO DIGITAL SIGNAL CONDITIONING FOR FLIGHT TEST G.A. Bever Published June 1991 90 pages</p> <p>This volume in the AGARD Flight Instrumentation Series provides flight test instrumentation engineers with an introduction to digital processes on aircraft. Flight test instrumentation systems are rapidly evolving from analog intensive to digital intensive systems, including the use of onboard digital computers. Topics include: measurements that are digital in origin, sampling, encoding, transmitting,</p> <p style="text-align: right;">P.T.O.</p>	<p style="text-align: center;">AGARD-AG-160 Volume 19</p> <p>Digital techniques Flight tests Data transmission Data processing Avionics Data buses Digital filters Aircraft Flight instruments</p>	<p>AGARDograph 160 Volume 19 Advisory Group for Aerospace Research and Development, NATO DIGITAL SIGNAL CONDITIONING FOR FLIGHT TEST G.A. Bever Published June 1991 90 pages</p> <p>This volume in the AGARD Flight Instrumentation Series provides flight test instrumentation engineers with an introduction to digital processes on aircraft. Flight test instrumentation systems are rapidly evolving from analog intensive to digital intensive systems, including the use of onboard digital computers. Topics include: measurements that are digital in origin, sampling, encoding, transmitting,</p> <p style="text-align: right;">P.T.O.</p>	<p style="text-align: center;">AGARD-AG-160 Volume 19</p> <p>Digital techniques Flight tests Data transmission Data processing Avionics Data buses Digital filters Aircraft Flight instruments</p>
<p>AGARDograph 160 Volume 19 Advisory Group for Aerospace Research and Development, NATO DIGITAL SIGNAL CONDITIONING FOR FLIGHT TEST G.A. Bever Published June 1991 90 pages</p> <p>This volume in the AGARD Flight Instrumentation Series provides flight test instrumentation engineers with an introduction to digital processes on aircraft. Flight test instrumentation systems are rapidly evolving from analog intensive to digital intensive systems, including the use of onboard digital computers. Topics include: measurements that are digital in origin, sampling, encoding, transmitting,</p> <p style="text-align: right;">P.T.O.</p>	<p style="text-align: center;">AGARD-AG-160 Volume 19</p> <p>Digital techniques Flight tests Data transmission Data processing Avionics Data buses Digital filters Aircraft Flight instruments</p>	<p>AGARDograph 160 Volume 19 Advisory Group for Aerospace Research and Development, NATO DIGITAL SIGNAL CONDITIONING FOR FLIGHT TEST G.A. Bever Published June 1991 90 pages</p> <p>This volume in the AGARD Flight Instrumentation Series provides flight test instrumentation engineers with an introduction to digital processes on aircraft. Flight test instrumentation systems are rapidly evolving from analog intensive to digital intensive systems, including the use of onboard digital computers. Topics include: measurements that are digital in origin, sampling, encoding, transmitting,</p> <p style="text-align: right;">P.T.O.</p>	<p style="text-align: center;">AGARD-AG-160 Volume 19</p> <p>Digital techniques Flight tests Data transmission Data processing Avionics Data buses Digital filters Aircraft Flight instruments</p>

and storing of data. Particular emphasis is placed on modern avionic data bus architectures and what to be aware of when extracting data from them. Some example data extraction techniques are given. Tradeoffs between digital logic families, trends in digital development, and design testing techniques are discussed. An introduction to digital filtering is also covered.

This AGARDograph was sponsored by the Flight Mechanics Panel of AGARD.

ISBN 92-835-0621-9

and storing of data. Particular emphasis is placed on modern avionic data bus architectures and what to be aware of when extracting data from them. Some example data extraction techniques are given. Tradeoffs between digital logic families, trends in digital development, and design testing techniques are discussed. An introduction to digital filtering is also covered.

This AGARDograph was sponsored by the Flight Mechanics Panel of AGARD.

ISBN 92-835-0621-9

and storing of data. Particular emphasis is placed on modern avionic data bus architectures and what to be aware of when extracting data from them. Some example data extraction techniques are given. Tradeoffs between digital logic families, trends in digital development, and design testing techniques are discussed. An introduction to digital filtering is also covered.

This AGARDograph was sponsored by the Flight Mechanics Panel of AGARD.

ISBN 92-835-0621-9

and storing of data. Particular emphasis is placed on modern avionic data bus architectures and what to be aware of when extracting data from them. Some example data extraction techniques are given. Tradeoffs between digital logic families, trends in digital development, and design testing techniques are discussed. An introduction to digital filtering is also covered.

This AGARDograph was sponsored by the Flight Mechanics Panel of AGARD.

ISBN 92-835-0621-9

The Mission of AGARD

According to its Charter, the mission of AGARD is to bring together the leading personalities of the NATO nations in the fields of science and technology relating to aerospace for the following purposes:

- Recommending effective ways for the member nations to use their research and development capabilities for the common benefit of the NATO community;
- Providing scientific and technical advice and assistance to the Military Committee in the field of aerospace research and development (with particular regard to its military application);
- Continuously stimulating advances in the aerospace sciences relevant to strengthening the common defence posture;
- Improving the co-operation among member nations in aerospace research and development;
- Exchange of scientific and technical information;
- Providing assistance to member nations for the purpose of increasing their scientific and technical potential;
- Rendering scientific and technical assistance, as requested, to other NATO bodies and to member nations in connection with research and development problems in the aerospace field.

The highest authority within AGARD is the National Delegates Board consisting of officially appointed senior representatives from each member nation. The mission of AGARD is carried out through the Panels which are composed of experts appointed by the National Delegates, the Consultant and Exchange Programme and the Aerospace Applications Studies Programme. The results of AGARD work are reported to the member nations and the NATO Authorities through the AGARD series of publications of which this is one.

Participation in AGARD activities is by invitation only and is normally limited to citizens of the NATO nations.

The content of this publication has been reproduced directly from material supplied by AGARD or the authors.

Published June 1991

Copyright © AGARD 1991
All Rights Reserved

ISBN 92-835-0621-9



Printed by *Specialised Printing Services Limited*
40 Chigwell Lane, Loughton, Essex IG10 3TZ

Preface

Since its founding in 1952, the Advisory Group for Aerospace Research and Development has published, through the Flight Mechanics Panel, a number of standard texts in the field of flight testing. The original Flight Test Manual was published in the years 1954 to 1956. The Manual was divided into four volumes:

- 1 Performance
- 2 Stability and Control
- 3 Instrumentation Catalog, and
- 4 Instrumentation Systems.

As a result of developments in the field of flight test instrumentation, the Flight Test Instrumentation Group of the Flight Mechanics Panel was established in 1968 to update Volumes 3 and 4 of the Flight Test Manual by the publication of the Flight Test Instrumentation Series, AGARDograph 160. In its published volumes AGARDograph 160 has covered recent developments in flight test instrumentation.

In 1978, the Flight Mechanics Panel decided that further specialist monographs should be published covering aspects of Volume 1 and 2 of the original Flight Test Manual, including the flight testing of aircraft systems. In March 1981, the Flight Test Techniques Group was established to carry out this task. The monographs of this Series (with the exception of AG 237 which was separately numbered) are being published as individually numbered volumes of AGARDograph 300.

At the end of each volume of both AGARDograph 160 and AGARDograph 300 two general Annexes are printed. Annex 1 provides a list of volumes published in the Flight Test Instrumentation Series and in the Flight Test Techniques Series. Annex 2 contains a list of handbooks that are available on a variety of flight test subjects, not necessarily related to the contents of the volume concerned.

The present Volume (No. 19 of AGARDograph 160) provides flight test instrumentation engineers with an introduction to digital processes on aircraft. Flight test instrumentation systems are rapidly evolving from analog intensive to digital intensive systems, including the use of onboard digital computers. Topics include: measurements that are digital in origin, sampling, encoding, transmitting, and storing of data. Particular emphasis is placed on modern avionic data bus architectures and what to be aware of when extracting data from them. Some example data extraction techniques are given. Tradeoffs between digital logic families, trends in digital development, and design testing techniques are discussed. An introduction to digital filtering is also covered.

Préface

Depuis sa création en 1952, le Panel de la Mécanique du vol, sous l'égide du Groupe Consultatif pour la Recherche et les Réalisations Aérospatiales a publié, un certain nombre de textes qui font autorité dans le domaine des essais en vol. Le Manuel des Essais en Vol a été publié pour la première fois dans les années 1954—1956. Il comportait quatre volumes à savoir:

- 1 Performances
- 2 Stabilité et Contrôle
- 3 Catalogue des appareils de mesure, et
- 4 Systèmes de mesure.

Les novations dans le domaine des appareils de mesure pour les essais en vol, ont conduit à recréer, en 1968, le groupe de travail sur les appareils de mesure pour les essais en vol pour permettre la remise à jour des volumes 3 et 4. Les travaux du groupe ont débouché sur l'édition d'une série de publications sur les appareils de mesure pour les essais en vol, l'AGARDographie 160. Les différents volumes de l'AGARDographie 160 publiés jusqu'à ce jour couvrent les derniers développements dans le domaine.

En 1978, le Panel de la Mécanique du vol a signalé l'intérêt de monographies supplémentaires sur certains aspects des volumes 1 et 2 du Manuel initial et notamment les essais en vol des systèmes avioniques. Ainsi, au mois de mars 1981, le groupe de travail sur les techniques des essais en vol a été recrée pour mener à bien cette tâche. Les monographies dans cette série (à l'exception de la AG 237 qui fait partie d'une série distincte) sont publiées sous forme des volumes individuels de l'AGARDographie 300.

A la fin de chacun des volumes de l'AGARDographie 160 et de l'AGARDographie 300 figurent deux annexes générales. L'annexe 1 fournit la liste des volumes publiés dans la série "Appareils de mesure pour les essais en vol" et dans la série "Techniques des essais en vol". L'annexe 2 donne la liste des manuels disponibles sur les mêmes thèmes dans le domaine des essais en vol, qui ne sont pas forcément en rapport avec le contenu du volume en question.

Ce volume 19 de l'AGARDographie 160 offre aux ingénieurs d'instrumentation des essais en vol une introduction au traitement numérique de bord.

Les systèmes d'instrumentation pour essais en vol, analogues jusqu'ici, sont en train d'évoluer très rapidement vers des systèmes numériques, qui intègrent des ordinateurs numériques de bord. Parmi les sujets examinés on distingue:

- les mesures d'origine numérique
- l'échantillonnage,
- le codage,
- la transmission,
- le stockage des données.

L'accent est mis en particulier sur les architectures modernes de bus de données avioniques et les consignes à donner à l'utilisateur qui veut en extraire des données. Quelques exemples de techniques d'extraction de données sont fournis. Les compris envisageables entre les différentes familles de logique numérique, les tendances en ce qui concerne les développements numériques et les techniques d'essais de prototypes y sont discutées, avec une introduction au filtrage numérique.

Acknowledgement to Working Group 11 Members

In the preparation of the present volume the members of the Flight Test Techniques Group listed below took an active part. AGARD has been most fortunate in finding these competent people willing to contribute their knowledge and time in the preparation of this volume.

La liste des membres du groupe de travail sur les techniques des essais en vol ont participé activement à la rédaction de ce volume figure ci-dessous. L'AGARD peut être fier que ces personnes compétentes aient bien voulu accepter de partager leurs connaissances et aient consacré le temps nécessaire à l'élaboration de ce document.

Appleford, J.K.		A&AEE/UK
Bogue, R.K.	(Editor)	NASA/US
Boischot, M.		CEV/FR
Bothe, H.		DLR/GE
Campos, L.M.B.		IST/PO
Delle Chiaie, S.		DASRS/IT
Langdon, G.		A&AEE/UK
Payze, T.		MSB/TU
Pool, A.	(Consultant)	NE
Russell, R.A.		NATC/US
van der Velde, R.L.		NLR/NE
Zundel, Y.		CEV/FR

R.R.HILDEBRAND, AFFTC/US
Member, Flight Mechanics Panel
Chairman, Flight Test Techniques Group

Contents

	Page
Preface	iii
Préface	iv
Acknowledgement to Working Group 11 Members	v
Summary	0-1
Objective	0-1
Nomenclature	0-1
1 Introduction	1-1
1.1 Definitions	1-1
1.2 Sampling in the Analog World	1-2
1.2.1 Common Examples	1-2
1.2.2 Effects and Pitfalls (Problem Areas)	1-3
1.3 Tradeoff Considerations	1-3
2 Digital Processes in Flight Testing	2-1
2.1 Avionics Systems	2-1
2.2 Data Acquisition Systems	2-1
2.3 Signal Processing-Conditioning	2-1
2.4 Hardware Considerations	2-1
2.4.1 Technology	2-1
2.4.1.1 Bipolar Logic	2-2
2.4.1.2 Emitter-Coupled Logic	2-2
2.4.1.3 CMOS Logic	2-3
2.4.1.4 Logic Families Compared	2-3
2.4.1.5 Problem Areas	2-5
2.4.1.6 Programmable Logic Devices	2-5
2.4.1.7 Hybrid Circuits	2-6
2.4.2 Environment Considerations	2-6
2.4.3 Architecture	2-6
2.5 Software Considerations	2-7
2.5.1 Languages	2-7
2.5.2 Software Development	2-8
3 Analog-to-Digital Interface	3-1
3.1 Analog-to-Digital Conversion Techniques	3-1
3.1.1 Successive Approximation	3-1
3.1.2 Integration	3-1
3.1.3 Multiple Comparator (Flash) Converter	3-2
3.1.4 Tracking Converter	3-3
3.1.5 Sigma Delta Converter	3-4
3.2 Digital-to-Analog Conversion Techniques	3-5
3.3 Digital-to-Synchro Conversion Techniques	3-6
3.4 Synchro-to-Digital Conversion Techniques	3-7
3.5 Conversion Process Considerations	3-7
3.5.1 Sample and Hold	3-7
3.5.2 Presample Filtering	3-8
3.5.3 Antialiasing Filtering	3-8
3.6 Process Error Sources	3-10

	Page
4 Digital Transducers	4-1
4.1 Transduction Techniques	4-1
4.1.1 Coded Disks	4-1
4.1.2 Variable Frequency	4-2
4.1.3 Pulse Techniques	4-2
4.2 Coding	4-2
4.2.1 Progressive Codes	4-2
4.2.2 Nonprogressive Codes (Gray)	4-3
5 Digital Filtering	5-1
5.1 Applications and Guidelines	5-1
5.2 Time Domain Filters	5-1
5.2.1 Nonrecursive Filters	5-2
5.2.2 Recursive Filters	5-2
5.2.3 Switched Capacitor Filters	5-2
5.3 Statistical Filtering	5-4
5.4 Data Compression Filtering	5-4
5.5 Pitfalls (Problem Areas) of Digital Filtering	5-4
6 Digital Communication	6-1
6.1 Technology Choices	6-1
6.1.1 Copper Wire	6-1
6.1.2 Fiber Optics	6-1
6.1.3 Telemetry	6-2
6.2 Transmission Timing Choices	6-2
6.2.1 Synchronous	6-2
6.2.2 Asynchronous	6-2
6.2.3 Isochronous	6-3
6.3 Communication Format Choices	6-3
6.3.1 Serial Transfer	6-3
6.3.2 Parallel Transfer	6-3
6.4 Data Formats	6-4
6.4.1 Timing and Synchronization	6-4
6.4.2 Error Detection and Correction	6-4
6.4.2.1 Parity Bit	6-4
6.4.2.2 Error Correction Code	6-5
6.4.2.3 Cyclic Redundancy Code	6-6
6.4.3 Data Packet Format	6-6
6.5 Standard Avionics Data Buses	6-6
6.5.1 MIL-STD-1553/1773	6-6
6.5.1.1 Terminal Types	6-7
6.5.1.2 Data Bus Cable	6-8
6.5.1.3 Terminal Characteristics	6-9
6.5.1.4 Data Bus Operation	6-9
6.5.1.5 Word Types	6-10
6.5.1.6 Word Formats	6-10
6.5.1.7 Bus Message Formats	6-11
6.5.1.8 MIL-STD-1553 Notices	6-13
6.5.1.9 Design Tips for MIL-STD-1553	6-13
6.5.1.10 MIL-STD-1773 and STANAG	6-14
6.5.2 ARINC 419/429/629	6-14
6.5.2.1 ARINC 419	6-14
6.5.2.2 ARINC 429	6-15
6.5.2.3 ARINC 629 (DATAC)	6-19
6.5.3 H009	6-20
6.6 General-Purpose Data Buses	6-21
6.6.1 RS-232/422/423/449	6-21
6.6.2 IEEE 488/HP-IB/IEC 625	6-24
6.6.2.1 Bus Operation	6-24
6.6.2.2 Bus Application and Limitations	6-25
6.6.3 Ethernet (IEEE 802.3)	6-25

	Page
6.7 Sampling Data Buses for PCM Transmission	6-26
6.8 Wave Shaping for Special Situations	6-27
6.8.1 Pulse Trains for Telemetry Transmission	6-27
6.8.2 Pulse Trains for Tape Recording	6-27
6.8.2.1 Filtering and Encoding Considerations	6-27
6.8.2.2 Enhancement Techniques	6-28
7 Digital Data Storage	7-1
7.1 Tape Recorders	7-1
7.2 Semiconductor Memory	7-1
7.2.1 Random Access Memory	7-1
7.2.2 Electrically Erasable Programmable Read Only Memory	7-2
7.3 Bubble Memory	7-2
7.4 Disks	7-2
7.4.1 Magnetic (Hard and Flexible)	7-2
7.4.2 Optical	7-3
7.4.3 Interfacing	7-3
8 Testing	8-1
8.1 Failure Modes and Mechanisms of Digital Systems	8-1
8.2 Hardware Test Methods	8-1
8.3 Software Test Methods	8-2
9 Reliability and Safety	9-1
9.1 Verification and Validation	9-1
9.2 Flight-Critical System Data Extraction	9-1
References	R-1
Index	I-1
Annexes	A-1

DIGITAL SIGNAL CONDITIONING FOR FLIGHT TEST

Glenn A. Bever
NASA Ames Research Center
Dryden Flight Research Facility
P.O. Box 273
Edwards, California 93523-0273
U.S.A.

SUMMARY

Flight test instrumentation systems are rapidly evolving from what was an all-analog technology into what will be an almost all-digital art. The development and widespread application of digital processes in data processing and reduction make it imperative that the advantages of the digital approach be exploited wherever appropriate in the flight test process. The areas of signal conditioning and data acquisition offer many opportunities to use digital techniques to achieve improved performance. For some time, digital techniques have seen much use in data acquisition systems. More recently, the use of digital computers in airborne systems has become commonplace, both in data acquisition systems and in the aircraft avionics and control systems. The computer brings an extensive capability for real-time processing to the onboard systems and, to realize its full potential, must be appropriately interfaced to the aircraft environment. Often, aircraft avionic digital systems contain data which are required for conducting the flight test. It becomes necessary to extract the data from the onboard systems for inclusion in the flight test database. For these reasons it is essential that the flight test instrumentation engineer understand digital signal conditioning techniques and be familiar with their applications.

OBJECTIVE

The objective of this volume is to provide the engineer with a limited theoretical basis, and with the necessary practical design information to permit the exploitation of the advances in the digital systems state of the art as applied to flight testing. Included in this objective is the use of digital techniques in strictly signal conditioning applications as well as interfacing and communication applications between various aircraft systems. Not included in this objective is the coverage of strictly computer-based systems information. This information is covered in computer society literature or in software professional society publications. These topics may be noted for consideration, but the reader is directed to other references for detailed subject coverage.

NOMENCLATURE

AC	alternating current or advanced CMOS
ACT	advanced CMOS TTL level
A-D	analog to digital
ALS	advanced low-power Schottky
AM	amplitude modulation
AND	logic "and" function
ANSI	American National Standards Institute
ARINC	Aeronautical Radio, Inc.
ASCII	American Standard Code for Information Interchange

BC	bus controller
BCD	binary-coded decimal
BIΦ-L	Manchester II biphase-level
BM	bus monitor
BNR	binary
CCITT	The International Telegraph and Telephone Consultative Committee
CMOS	complementary metal oxide semiconductor
CRC	cyclic redundancy code
D-A	digital to analog
DAC	digital-to-analog converter
DATAAC	digital autonomous terminal access communication
DC	direct current
DCE	data communication equipment
DCTL	direct-coupled-transistor logic
DEEC	digital electronic engine control
DITS	digital information transfer system
DM-M	delay modulation-mark (Miller)
DoD	Department of Defense (U.S.A.)
DTE	data terminal equipment
DTL	diode-transistor logic
ECC	error correction code
ECL	emitter-coupled logic
EEPROM	electrically erasable programmable read-only memory (also known as E ² PROM)
EFA	European fighter aircraft
EMI	electromagnetic interference
EPLD	electrically programmable logic device
ESDI	enhanced small device interface
ESD	electrostatic discharge
EU	engineering units
FAST	Fairchild advanced Schottky TTL
FET	field effect transistor
FIFO	first in, first out
FIR	finite impulse response
FM	frequency modulation
FTI	flight test instrumentation

GP-IB	general-purpose interface bus
HC	high-speed CMOS
HCT	high-speed CMOS TTL level
HP-IB	Hewlett-Packard interface bus
IC	integrated circuit (chip)
IEC	International Electrotechnical Commission
IEEE	Institute of Electrical and Electronic Engineers
IIR	infinite impulse response
IRIG	Inter-Range Instrumentation Group (U.S.A.)
IRU	inertial reference unit
ISO	International Standards Organization
LS	low-power Schottky
LSB	least significant bit
LSD	least significant digit
LSI	large-scale integration
MIL-STD	military standard
MODEM	modulator-demodulator
MOS	metal oxide semiconductor
MSB	most significant bit
MSCP	mass storage control protocol
MSD	most significant digit
NASA	National Aeronautics and Space Administration (U.S.A.)
NRZ	nonreturn to zero
PAL	programmable array logic
PCM	pulse-code modulation
PLA	programmable logic array
PLD	programmable logic device
R	resistance
RAM	random access memory
RC	resistance-capacitance
RF	radio frequency
RH	rotor reference high
RL	rotor reference low
RMI	radio magnetic indicator
RT	remote terminal
RTL	resistor-transistor logic

RZ	return to zero
rms	root mean square
rpm	revolutions per minute
rps	revolutions per second
SAE	Society of Automotive Engineers
SCSI	small computer systems interface
SDI	source designation indicator
SDLC	synchronous data link control
SM	status matrix
SSI	small-scale integration
SSM	sign-status matrix
ST506	Seagate disk interface standard
T/R	transmit-receive
TTL	transistor-transistor logic (bipolar)
UV	ultraviolet
V	volts
VAC	volts alternating current
VDT	video display terminal
WORM	write once, read many

Symbols

<i>C</i>	capacitor
<i>D</i>	digital output
<i>E</i>	electromotive force (voltage)
<i>f</i>	frequency
<i>I</i>	current
<i>H</i>	matrix
<i>k, m, n</i>	variables
<i>P</i>	parity
<i>Q</i>	charge
<i>R</i>	ratio
<i>S</i>	signal
<i>T</i>	time between successive closings
<i>Z</i>	impedance
Ω	ohms

Subscripts

<i>ave</i>	average
<i>clk</i>	clock
<i>G</i>	ground
<i>H</i>	high
<i>IH</i>	input high
<i>IL</i>	input low
<i>in</i>	input
<i>n</i>	variable
<i>O</i>	characteristic or nominal
<i>OH</i>	output high
<i>OL</i>	output low
<i>out</i>	output
<i>pl</i>	passband lower
<i>pu</i>	passband upper
<i>ref</i>	reference
<i>s</i>	source
<i>sl</i>	stopband lower
<i>su</i>	stopband upper

1 INTRODUCTION

Traditionally, engineering disciplines surrounding flight test have been broken into several groups. Groups concerned with flight operations, flight control, aerodynamics, propulsion, and instrumentation existed with a great deal of autonomy. More recently, aircraft are being viewed and tested as a complete aircraft SYSTEM. The dividing lines between disciplines have become very indistinct. Information about fuel distribution may be input to control systems that adjust for center of gravity change. Digitally controlled propulsion systems may integrate their calculations with the flight control system. System designers require data from these systems to evaluate their performance or safety. Instrumentation engineers are taking advantage of sensors embedded into avionics packages rather than installing their own unique sensors.

More demanding requirements are driving aircraft systems to be more integrated. Many processes traditionally done on the ground are moving into aircraft systems. Improving digital electronic technology is making aircraft systems possible that were impossible just a few years ago. Optical technologies loom on the horizon. The rapid progress in the state of the art requires individuals charged with designing aircraft measuring systems to become better acquainted with new solutions to their requirements.

This volume is concerned with aircraft measuring systems as related to flight test and flight research. Measurements that are digital in origin or that must be digitized are discussed. Sampling, encoding, transmitting, and storing the data are dealt with. Examples of actual solutions to these problems will be given. This volume will provide an overview and introduction to the various areas of concern in modern aircraft digital measurement. Processes taking place on the aircraft rather than on the ground are emphasized.

There is no one right way to instrument an aircraft. Different organizations have different goals and requirements. An aircraft manufacturer has a different emphasis than an organization concerned with basic aerodynamic research. The manufacturer's primary concern is to validate the aircraft design and to prove its safety. While a military flight testing organization may be more concerned with gaining experience in a particular aircraft to write flight manuals, a flight research organization may be more concerned with measuring the airflow over a wing or doing precise wind calculations. Some organizations can design in the test instrumentation when the aircraft is built. Others are faced with the task of installing equipment in places that the designers never envisioned.

For example, designers of avionics systems in civil transport aircraft proceed from a rigid criteria for avionics box size and function. The designer of flight test instrumentation for fighter or small civil planes is more likely to use criteria "as small as is practicable" with a function uniquely defined by the flight test program.

The organizations' diverse missions, together with the natural tendency to continue with familiar approaches to problems and equipment, create a wide range of solutions to flight measurement problems.

1.1 Definitions

What parameters are measured in flight that are of concern to digital signal conditioning? Nearly all parameters in modern flight test eventually become digital. Even analog sensors are digitized for inclusion into databases at some point. Avionic systems communicate by way of digital data buses. And increasingly, data is being digitally stored in memory, tape, and disk. The following basic terms found in this volume are defined.

A **measurand** is the physical quantity to be measured, such as temperature, pressure, or strain.

A **transducer** is a device that converts a measurand into another form of energy. For flight test instrumentation, this energy is typically electrical or optical.

Signal conditioning is necessary to convert a transducer output to a form required for input to a recorder, computer, or telemetry device.

Digital signal conditioning is defined as converting a transducer output signal to the digital domain and passing it to a recording, computing, or telemetry device. Conditioning or altering signals between different forms in the analog domain is not discussed in this volume. See reference 1 for a discussion of this topic.

1.2 Sampling in the Analog World

The adage “to measure is to change” sums up the skill required to measure phenomena. The problem is twofold. First, probing a medium disturbs it. Second, no measuring device is perfect. Correct interpretation of how much the medium has been disturbed and how much error that contributes along with sensor imperfection is the key to correct interpretation of the results.

When a conversion is made, whether between human languages or between analog and digital, something is lost in the translation. It is a truism that because it has been changed, it is different. The advantage of handling data in the digital regime is that it is much less sensitive to further degradation than is a signal in the analog domain. Because a digital signal is passed as a two-state value, wide tolerances in the signal levels can be accepted and still retain the information (fig. 1-1(a)). However, most measurands of interest are more appropriately thought of as being in the analog domain (signal amplitude varies with time). Figure 1-1(b) shows a sample analog signal. Most measurands vary in small amounts, not large (digital) jumps. The problem, then, becomes one of translating analog phenomena into a digital signal while keeping introduced error to a known minimum.

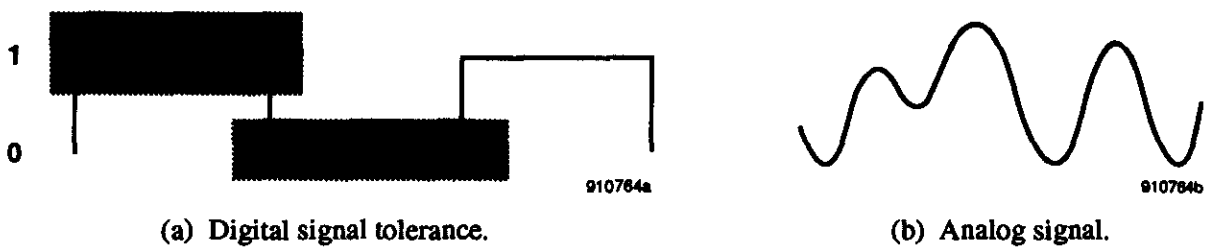

Figure 1-1. Digital and analog signals.

1.2.1 Common examples

Figure 1-2 shows a typical aircraft data acquisition system. Data flow from the sensors to the recording mechanism. Note that regardless of the sensor type, the data become digitized for recording. There are many ways to send the data through the system. The method shown converts each of the inputs to a parallel digital word. The sequencer then multiplexes these digital words in a repeating sequence and sends each digital word out in serial. Synchronization words are added to assist data reconstruction later. This serial bit stream is finally recorded on tape and transmitted.

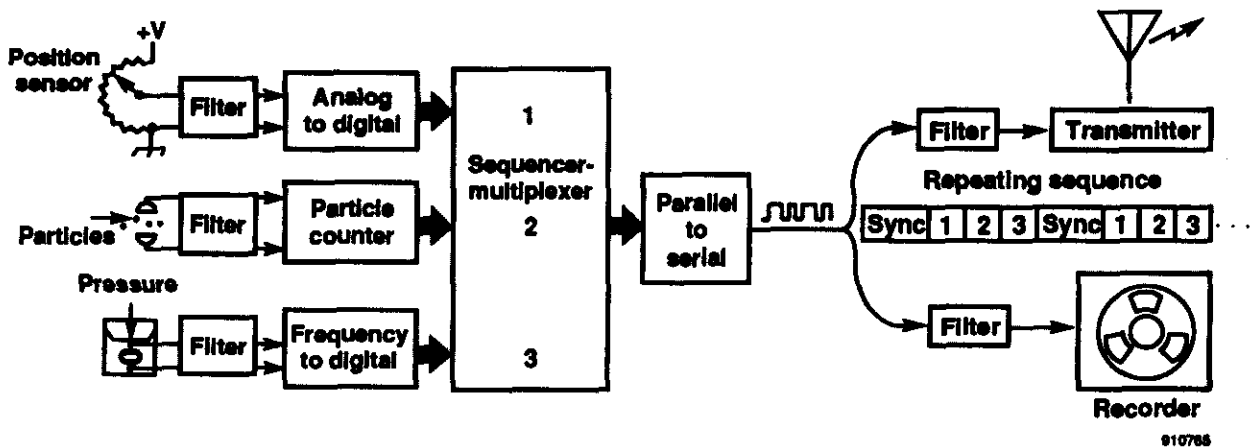

Figure 1-2. Simplified aircraft data acquisition system.

1.2.2 Effects and pitfalls (problem areas)

Sampling introduces its own problems. Sampling is looking at a signal at discrete moments in time. The more the signal is looked at, the more the sampling rate increases. In theory, as the sampling rate approaches infinity, the original signal is seen, with no error introduced in sampling. However, in reality the signal must be sampled less than infinitely often. Sampling circuit limitations, as well as limitations in ability to process, transmit, or record high data rates, force decisions about how fast the signal must be sampled. If the sampling rate is too low, important information can be lost. Sampling too high wastes bandwidth resources.

Consider an 8-Hz signal sampled only once. The reconstructed signal will look like a DC level whose amplitude is whatever the signal happened to be when it was sampled that one time. This is an extreme example of a phenomena known as aliasing and is discussed in section 3.5.3.

1.3 Tradeoff Considerations

While sampled data systems can lose important information if sampled too low, there are other factors that can lead to loss of data. Filtering techniques employed to assure that aliasing does not occur must be applied BEFORE sampling (sec. 3.5.3). Electronic filtering cannot be used, for example, where scanning pressure transducers are used. The only antialiasing filtering that can be done here is in the mechanics of the pressure lines.

Techniques other than sampled systems can be subject to the same deficiencies. Systems like FM recording—where an analog voltage modulates a frequency around a carrier center—are thought to be “continuous.” However, an FM signal cannot be demodulated at one discrete point in time. It takes at least two points, usually two zero crossings, to determine the frequency AT that time. This implies that arbitrarily large input variations (continuous signals) cannot be supported because of the finite time it takes to demodulate a particular frequency. Instantaneous determination of frequency at infinite resolution is required to actually support a continuous analog input. This is analogous to saying that the system must have an infinite number of samples to be truly a continuous reading, which is impossible. Everything has a bandwidth, although some bandwidths are larger than others. Because the carrier is centered at a particular finite frequency and doesn't have an infinite modulation rate, the ability of the carrier to “carry” information could be exceeded.

Another example is an AM signal. Figure 1-3(a) shows a modulated carrier. To reconstruct the information, there is an interpolation connecting the dots shown broken out (fig. 1-3(b)). This process is identical to the process of reconstructing a sampled signal. If the carrier frequency is too low for the information it carries, there won't be enough dots to connect and still retain the information required and aliasing will take place.

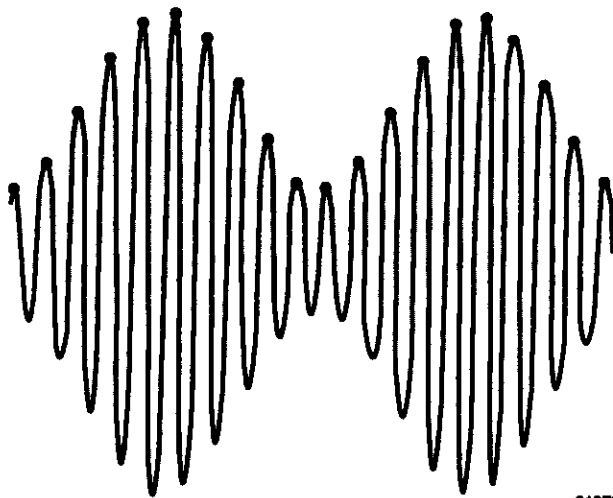

910766a

(a) Amplitude-modulated waveform.

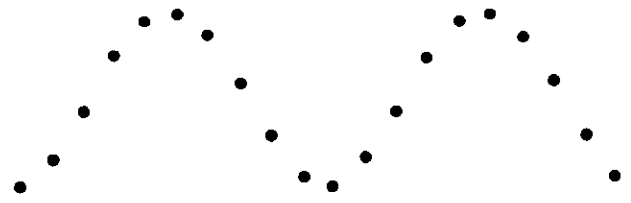

910766b

(b) Demodulated waveform, sampled.

Figure 1-3. Sampling nature of amplitude modulation.

2 DIGITAL PROCESSES IN FLIGHT TESTING

2.1 Avionics Systems

The word "avionics" is a contraction of the words "aviation" and "electronics," and it may include all electronic subsystems on an aircraft. In particular, avionics refers to those electronic subsystems that are directly concerned with flight control, weapon systems, navigation, and cockpit display. In most aircraft, these systems are part of the operational aircraft, and modifications to these systems are not regarded lightly. They are designed to exacting specifications, and packaged to facilitate easy replacement by nonexperts.

Avionics systems, as defined previously, are not the subject of this AGARDograph. See reference 2 for more information on avionics systems. However, because flight testing frequently requires their data, some avionic communication standards are discussed in section 6.

2.2 Data Acquisition Systems

Flight testing requirements usually have different ground rules than avionics systems, as defined earlier. Easy replacement of data acquisition equipment is, of course, desirable. But more important is how flexible the system is, how easy it is to alter (to test other flight conditions), and how small it is. Data acquisition traditionally is open loop; that is, data are acquired and stored or transmitted for analysis, but not fed back into the aircraft to control it. A test display may be available to the pilot, but this is seldom a display certified for safe flight reference.

2.3 Signal Processing—Conditioning

Referring back to figure 1-2, notice that three different types of sensors are shown. The position sensor, which may measure control surface position, is a potentiometer whose voltage output varies proportionally with wiper position. This analog output must be converted to a digital word. The particle sensor must convert individual particle detection to an aggregate total number of particles detected. The pressure sensor output is a frequency that is proportional to the pressure applied. This frequency must also be converted to a digital value for use in the data acquisition system.

Some sensors are regarded as "digital" sensors because the conversion to the digital domain (conditioning) is done at the sensor. For example, if the only output from the "sensor" box is digital, then it is transparent to the engineer using it that the pressure sensor is an element of a tuned circuit (the output of which is frequency).

Once the initial "conditioning" to the digital domain is done, then the data must be finally passed to some recording mechanism. This may mean that the data need to be further conditioned to ease their transfer. For instance, again referring to figure 1-2, the data are multiplexed, converted to serial (changing their condition again), and then perhaps filtered (further conditioned) for telemetry transmission or onboard recording. The data may be used onboard in computations for cockpit displays or data thinning. This type of signal processing is increasingly common. The conversions and filtering are performed on the digital data to ease their transfer and in no way alter the basic digital information content.

2.4 Hardware Considerations

2.4.1 Technology

Improvement of electronic technology has proceeded at an incredible rate. It is difficult to maintain an awareness, much less a proficiency, in every development that enters commercial production. Generally, an electronic designer working against a deadline will design with the familiar. Taking the time to learn the ins and

outs of a new technology is a luxury that frequently cannot be indulged in. Often new techniques must be used, particularly when requirements dictate lower power, higher speeds, and smaller package size than what can be provided with known techniques.

The design engineer often needs to have experience with new technology and techniques before recommending it. There are too many unknowns to make a firm commitment to schedule. Technique advancement then requires a far-sighted project manager or a risk-taking design engineer willing to spend long hours perfecting the understanding of the technique in question.

There are currently several technologies to choose from when selecting components to implement digital logic circuits. Details of these devices are found in manufacturers' data books (refs. 3 through 7). Reference 8 discusses technology family tradeoffs. The basic tradeoffs made in selecting a logic family are power consumption, gate speed, noise immunity, circuit density, output drive (fan-out), cost, and reliability.

2.4.1.1 Bipolar logic

This line of logic components is the first line of digital integrated circuits to come into commercial usage. The technique uses bipolar transistors. Historically, the order of development and usage was:

- Direct-coupled-transistor logic (DCTL)
- Resistor-transistor logic (RTL)
- Diode-transistor logic (DTL)
- Transistor-transistor logic (TTL)

A DCTL device had poor noise immunity and high current consumption. An RTL device was low speed, and had poor noise immunity and low fan-out. A DTL device reduced power requirements, but at the expense of being slower. All of these technologies are obsolete and are not used in new designs.

The TTL devices have been by far the most popular logic family for nearly 20 years. This logic, or variations of it, can still be found in new designs, although its popularity is waning. It boasts higher noise immunity than its predecessors and is faster. Subfamilies of TTL have been introduced to improve various characteristics, like lower power consumption or higher speed. A commercial logic-integrated circuit (IC) is easily recognized by its prefix of 74. A military specification IC prefix is generally 54. The subfamilies follow the prefix with letters indicating the subfamily, as follows:

- AS Advanced Schottky
- ALS Advanced low-power Schottky
- H High speed (up to 50 MHz)
- L Low power (up to 3 MHz)
- LS Low-power Schottky (up to 45 MHz)
- S Schottky (up to 125 MHz)

Bipolar logic families are inherently current devices, because bipolar junction transistors are current driven. Therefore, output drive is limited to some finite number, usually stated in terms of how many logic *inputs* (in the same logic family) can be fed before the current demand moves the output voltage into the transition (indeterminate) region. This unit of drive capability is called the fan-out. Fan-out for TTL devices is usually around 10. Switching speeds are regarded as fast because of the use of transistors rather than passive resistor-capacitor coupling between most stages.

2.4.1.2 Emitter-coupled logic

Emitter-coupled logic (ECL) is characterized by extremely high speeds, into the 1- to 2-GHz range. The tradeoff is that it also has high power consumption and low circuit density. The ECL operates in the active region of the transistor—which enhances its speed. The high power consumption and low circuit density limit its use on aircraft. It is seen primarily in mainframe computers.

2.4.1.3 CMOS logic

Complementary metal oxide semiconductor (CMOS) logic circuits are voltage driven rather than current driven as bipolar circuits are. They are voltage driven because CMOS uses field effect transistors (FET's), which are voltage-driven devices. This is what allows for the low power consumption of CMOS devices. With a constant voltage and low current leakage, power dissipations in the microwatts can be achieved. Voltage-driven gates also allow for much larger fan-outs than can be achieved with bipolar devices.

The CMOS device has existed for several years in the form of the 4000 series parts. It boasts high noise immunity and extremely low power consumption, which has made it popular for battery-operated equipment. However, 4000 series CMOS is very slow when compared with the bipolar logic families (fig. 2-1).

As technology has progressed, other CMOS logic families have been developed to be plug replaceable with existing bipolar logic families. For example, the 54HC/74HC family was designed to replace the 54LS/74LS bipolar family. It retains much of the bipolar speed but reduces the power consumption while improving noise immunity characteristic of CMOS. Later, the 54AC/74AC family was designed to replace the 54HC/74HC family while increasing the speed.

2.4.1.4 Logic families compared

Table 2-1 shows a comparison of several logic families. The function chosen for comparison is a quad 2-input AND (four AND gates). The table is generally ordered from slowest to fastest logic part. Figure 2-2 shows the input and output current and voltage-naming conventions used in table 2-1. Figure 2-1 graphically illustrates the speed-power tradeoffs between logic families. Note that the AC and ACT logic families generally yield the best speed *and* the lowest quiescent power.

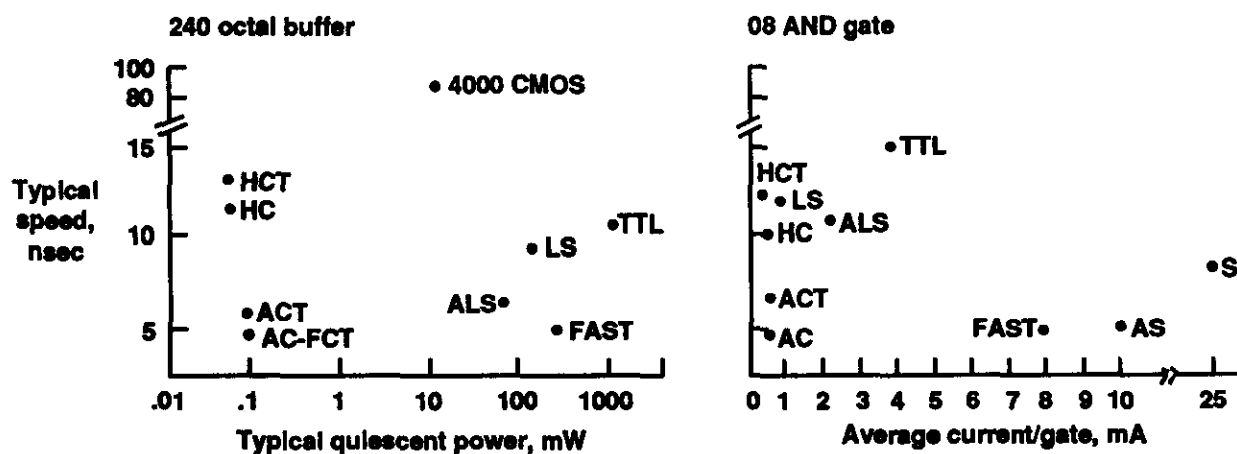

910767

Figure 2-1. Logic family speed as a function of power consumption.

Table 2-1. Comparison of logic families.

Chip	Input						Output							
	V	I	V	V	I	I	V		V		I	I	t	
74/54	(V)	Supply ave (mA)	MAX Lo (V)	MIN Hi (V)	At Lo (mA)	At Hi (mA)	MAX Lo (V)	Typical Lo (V)	MIN Hi (V)	Typical Hi (V)	Sink at Lo (mA)	Source at Hi (mA)	Propagation delay MAX (nS)	Typical (nS)
08	5.0	3.88	0.8	2.0	-1.6	0.04	0.4	0.2	2.4	3.4	16	-0.8	27	15
LS08	5.0	0.85	0.8	2.0	-0.36	0.02	0.5	0.35	2.7	3.4	8	-0.4	24	12
HCT08	4.5	0.04	0.8	2.0	-0.001	0.001	0.33	0.2	3.84	4.2	~3.6		35	12
HCO8	4.5	0.04	0.9	3.15	-0.001	0.001	0.33	0.2	3.84	4.2	~3.6		20	10
ALS08	4.5	2	0.8	2.0	-0.1	0.020	0.5	0.35	V-2		8	-0.4	18	~11
S08	5.0	25	0.8	2.0	-2	0.05	0.5		2.5	3.4	20	-1	7.5	
ACT08	4.5	0.04	0.8	2.0	-0.001	0.001	0.40		3.76		57	-50		6.7
AC08	4.5	0.04	1.35	3.15	-0.001	0.001	0.1		V-0.1		24		12	5
F08	5.0	8	0.8	2.0	-0.6	0.020	0.50	0.35	2.7	3.4	20	-1	6.6	4.2
AS08	4.5	10	0.8	2.0	-0.5	0.020	0.5	0.35	V-2		20	-2	6.5	~4

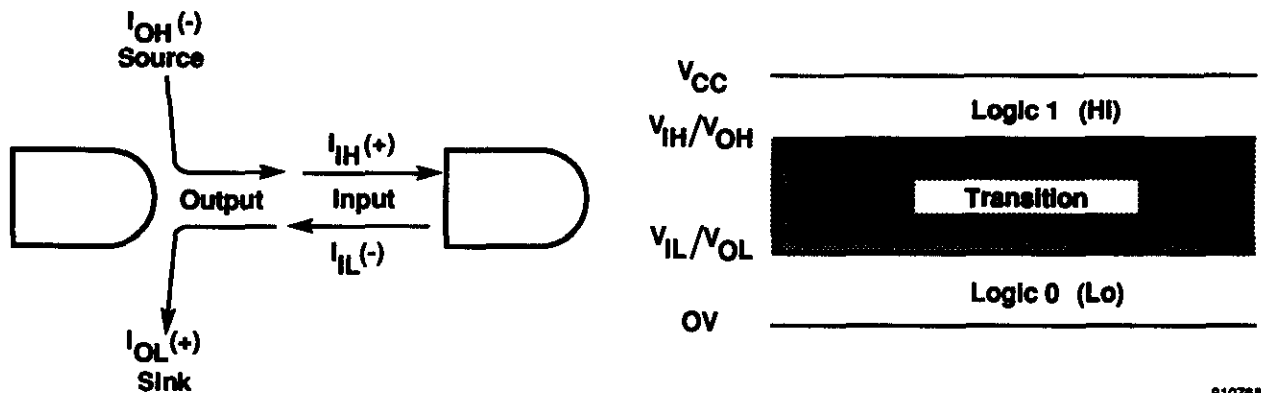
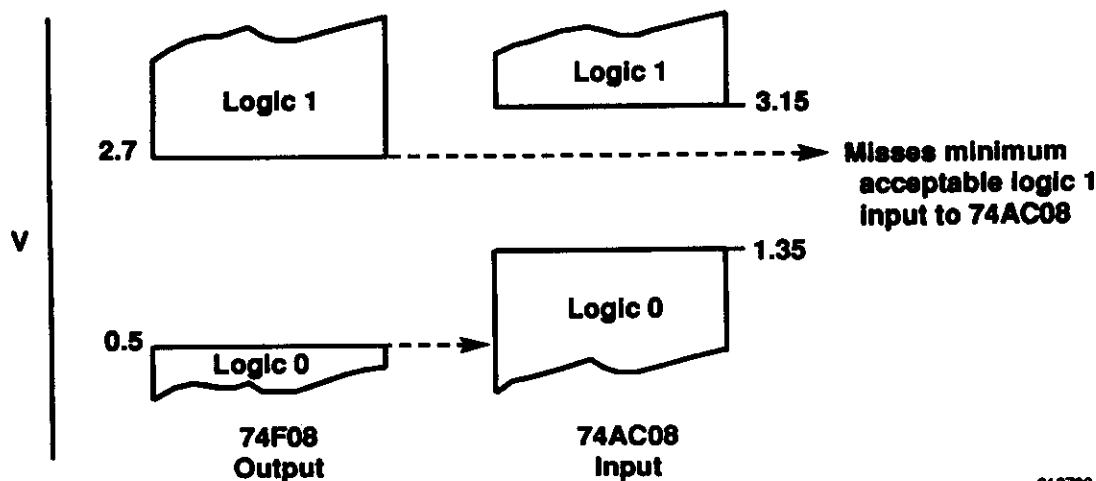

Figure 2-2. Logic circuit parameter-naming conventions.

910798

Whereas older MOS gates, although less “power hungry,” were considerably slower than TTL bipolar parts, newer metal oxide semiconductor (MOS) devices not only use much less quiescent (steady state) power than TTL, but they are also faster and more noise immune. They also retain the circuit densities that have made large-scale integration possible.

Minor problems arise when mixing logic families. In table 2-1, the differences in the input and output threshold voltages can result in “illogical” logic. For example, the 74AC08 expects logic “1” inputs to be no less than 3.15 V, whereas a 74F08 logic “1” output may be as low as 2.7 V (fig. 2-3). Where a 74F08 output is feeding a 74AC08 input, a pullup resistor is required to pull the 74F08 output higher when it’s in the logic “1” state. This has an impact on both component count (adding resistors) as well as gate-transition speed.



010700

Figure 2-3. Logic family interfacing problem.

The HC family can replace LS logic if all the logic were LS. However, there is both an HC and HCT family (as well as AC and ACT) because of this interfacing problem. As long as the entire design uses LS logic, either HC or AC logic can replace it. However, the design may rely on maintaining LS voltage levels for other logic interfacing. Because HC improves noise immunity by wider separation of acceptable input voltages for logic "1" or "0" than does LS logic, problems may arise. Therefore, HCT and ACT logic families were developed. They retain the reduced power consumption of the HC and AC families, but sacrifice the improved noise immunity in favor of mimicking LS tolerance levels.

2.4.1.5 Problem areas

The improvements made in logic are not a panacea. New problems have arisen that require watching. For instance, CMOS logic outputs have higher output impedance (Z) than bipolar families. Although CMOS has higher noise immunity than bipolar families (because of greater separation of logic output voltages), they are more susceptible to external signal coupling as a result of their higher Z . Care must be taken in circuit layout to minimize crosstalk.

The AC logic is susceptible to a condition known as "ground bounce." This condition occurs when logic tolerances are altered because of high frequency signals.

2.4.1.6 Programmable logic devices

The most interesting logic devices to gain popularity lately are programmable logic devices (PLD's). Different manufacturers refer to this class of device by various names like programmable array logic (PAL) and programmable logic array (PLA). The underlying idea is the same: they are hardware logic gates and flip-flops whose interconnections are programmable. Some devices are programmed once only. That is, once programmed, they cannot be altered again. Others are ultraviolet (UV) erasable electrically programmable logic devices (EPLD's) and can be reprogrammed. All of these devices offer the best of both worlds—the speed of hardware logic and the flexibility of programming. In essence, it is a way of programming hardware.

Making logic changes is as easy as reprogramming an IC rather than (necessarily) requiring circuit board modifications. PLD's also allow more customized "hardwired" logic to be packed into a small area. The major drawback is that their speeds never match small-scale integration (SSI) logic like the AND gates described earlier. Also, it may be more difficult to troubleshoot the logic if the signals requiring monitoring are buried inside the PLD with no external leads.

2.4.1.7 Hybrid circuits

When it is necessary to miniaturize systems, hybrid circuits may become necessary. Hybrid circuits are a group of monolithic IC's, resistors, and capacitors that are wired as a circuit. A unique quality of hybrids is that the IC's are the "chips"—without their carrier package, which saves board space. The hybrid technique requires manual fabrication, a disadvantage which drives up the cost. Savings of scale are minimal because of the manual labor involved.

2.4.2 Environmental considerations

Airborne electronics often encounter a wide range of environments. For example, a fighter aircraft may absorb tremendous heat sitting on a ramp in the desert. The aircraft then takes off and flies to high altitudes (low ambient pressure) where ambient temperatures are -50°C , then returns to the hot desert floor. The same aircraft might be flown from the deck of a damp aircraft carrier. The possibility of high electromagnetic radiation environment operation must be considered as well.

Operational aircraft electronics are designed to withstand all the extremes just listed. This dramatically increases the cost of flight systems as a result of more difficult design and manufacturing constraints plus required testing.

Often in flight test, design criteria can be relaxed considerably because the mission ground rules can be more controlled. In most cases, instrumentation equipment failure results in the termination of data acquisition and does not endanger the safety of the aircraft. Also, mission rules may dictate operating only in clear weather when the ramp temperatures are below 30°C . The test instrumentation could be located in a pressurized area where there is good airflow. These rules would allow the instrumentation to be less expensive and to be designed more quickly.

Another environmental consideration that is gaining importance is electrostatic discharge (ESD). Static electric charges build up on the bodies of personnel. An example of electrostatic discharge is the spark generated when reaching for a doorknob on a dry winter day. The discharge can cause electronic components to be damaged or destroyed. Less known is that ESD can damage electronic components even when it hasn't built to the level of discharging a spark. This sensitivity to ESD worsens as IC fabrication technologies shrink IC line widths to fit more logic on a substrate. Precautions must be taken to prevent damage. Personnel working with electronics must be grounded through high-impedance leads. High-impedance leads allow a charge to drain off gradually. If a charge drains instantaneously, high currents would flow or a spark would occur.

2.4.3 Architecture

There are many ways to design a data acquisition system. In most engineering endeavors, compromises must be made depending on design constraints. For example, constraining a system to be under 1000 cm^3 and less than 5 kg probably constrains the power dissipation, but not the cost. Optimizing the cost may minimize the channels available and determine minimum size possible.

As table 2-1 illustrates, modern logic families are becoming faster and dissipate less power than before. The size of IC components is also shrinking, which means that more electronics per unit area is possible. This in turn drives up the dissipation requirements. While the units are shrinking, the computational requirements are increasing. These increased computational requirements can drive an increase in unit size. The usual tradeoff is size as opposed to performance.

Data acquisition on an aircraft can be categorized into three basic groups: centralized, distributed, and separate. A centralized data acquisition system has one central controller that directly controls the data acquisition of all the sensors. It also determines what the output data stream will be. Refer to figure 1-2 for a simplified example.

A distributed data acquisition system is more loosely coupled. It may be thought of as several "central" data acquisition systems that share information—usually through digital serial channels. One system directs the sampling of the rest, but the actual sampling, filtering, and conversion into digital form is done at each remote location. Distributed systems are important when long lengths of thick wire bundles must be avoided, such as on large aircraft with widely separated sensors or on small aircraft with no room for wire bundles. "Separate" data acquisition systems coexist on an aircraft but have nothing to do with each other. This is frequently the simplest approach but has the disadvantage of not allowing all the aircraft data acquisition to be synchronized. Although this approach may work for "gross" observation of data, it is frequently intolerable for research.

2.5 Software Considerations

2.5.1 Languages

There was a time when a clear delineation was made between software and hardware. To a software engineer, hardware was something that software was run on. To a hardware engineer, software was the afterthought of the hardware buildup process.

With aircraft, if software was needed, it was in assembly language. This was the responsibility of the hardware engineers. Aircraft systems had to run fast. Programming was viewed as logic replacement, and software was embedded into the hardware. The fastest way to run code was to program in machine code or its slightly more human readable form called assembly language.

With the advent of highly digital aircraft, the thought of programming and verifying several interconnecting digital systems all programmed in assembly language is horrifying. The difficulty in "thinking like a machine" is increased considerably because of the complexity of several, usually asynchronous, systems. Increased processing speeds and higher density memories have allowed higher level languages to be considered for many onboard systems.

A high-level language allows the programmer to write code in a more abstract manner—the programmer's attention can be spent more on solving the problem than on moving bits around a machine—which is where much of the assembly language programmer's time is spent. The tradeoff is that the programmer *has* less to do with the machine level and a certain level of control is lost. With a high-level language, overhead is increased (taking more time and memory to execute code). But time to code the solution is usually decreased (more time spent on solving the problem and less time telling the machine how to implement it).

Many high-level languages are in use. Four of the most representative and important languages are FORTRAN, PASCAL, "C," and ADA. The FORTRAN (FORmula TRANslation) language has existed since the 1950's and is still a very well understood and popular language. It excels at just that—translating formulas ("number crunching"). In earlier forms it relied on a "threaded code" concept to pass control around a program. This form is more difficult to follow than the so-called structured program concept used by FORTRAN 77 and the quintessential model of structured programming, PASCAL.

The PASCAL language was developed to teach students good structured programming concepts. To this end, it maintains a "death grip" on programming technique. It also separates the programmer from the hardware—by definition. PASCAL is largely self-documenting. Variables are strongly typed (integer, real number, logical variable, and so forth), and the use of pointers and record structures allows queues, linked lists, and data structures to be implemented easily. The main drawback for embedded data system applications like aircraft avionics is that the real world intrudes on this view of a structured universe and hooks into the hardware must be provided. Because PASCAL (in standard implementations) is hard to fool, the usual approach is to call assembly language subroutines to do the hardware access. The programmer will then spend time working around the program to accomplish the task.

The "C" language was developed at Bell Labs, Murray Hill, New Jersey. Its main purpose was to build operating system elements—UNIX in particular. There are two advantages to this. First, the operating system

programmer can write the operating system code in a high-level language. Second, the operating system is more portable between computers because the system programming is written at the abstract level and not at a machine dependent, assembly language level. But operating systems must deal with the real world of system input-output (disk read-writes, terminal access, printing, and so forth). The "C" program is less strongly typed than PASCAL and allows much "bit twiddling," or bit manipulations. In fact, "C" fits in a niche between assembly code and PASCAL. It includes data structures, block structuring of code, and high-level parsing of coding, and allows the programmer to bypass much of it. Usually, when high-level language concepts are bypassed, the code is less portable. Also, "C" language is frequently less readable. As "C" is a very cryptic language, considerable attention must be paid to making it readable. It is not a self-documenting language.

The most touted and controversial high-level language to come along in recent years is ADA. Unlike "C" or PASCAL, which came out of development groups and universities and gained acceptance in a "bottom up" fashion, ADA is advocated by the U.S. Department of Defense (DoD) as a standard language for *all* coding done on its programmable systems. The advantage of this standardization is that overall system maintenance costs are minimized because larger pools of expertise are maintained. The ADA language is designed to be all things to all people. It developed out of committee (top down) and is a *very* large compiler. It is so large and so slow, in fact, that the writing of compilers for different machines and the verification of them is a long process. By definition no extensions are allowed, so all bases must be covered within the language. The end result is a language that is too large and too slow for many of the microprocessor-embedded applications (including logic replacement functions) on board aircraft. However, because DoD is mandating its use, the flight test community must take ADA seriously.

2.5.2 Software development

Software development, like hardware development, requires a clear definition, a development plan, and a verification process of the problem to be solved. Tools are needed for writing the code and debugging it. The time and tools required to debug software are frequently underestimated. "Data crunching" software requires no interface other than disk drives, a printer, and an operator terminal. Software designed for flight activity interfaces to many other systems. These systems usually have their own ideas as to when to send and receive signals, as they are related to real-time processes.

Usually, the code cannot be fully tested until it has been run on the aircraft and connected to the systems used in flight. Some simulation can be done before this. Software modules can be written to simulate (in a parameter-passing sense) the aircraft systems. Language debuggers can be used to examine trouble spots in code execution. But timing checks are very difficult to do without connecting to the aircraft systems. Sometimes code is written on one type of computer and the execution is targeted for another type of computer. This process is called cross-compilation or cross-assembly, depending on whether a compilation or assembly is done. Cross-compilation or cross-assembly allows common ground-based computers (designed for general-purpose use) to be used as a tool in developing code for a system that is optimized as an embedded system.

3 ANALOG-TO-DIGITAL INTERFACE

3.1 Analog-to-Digital Conversion Techniques

Analog-to-digital (A–D) conversion is central to most data acquisition systems. If a time-varying voltage is the output of a sensor, and the data will be stored in a digital fashion, it must be converted from the analog domain to the digital domain. There are several ways to perform this conversion. This section will briefly describe the methods and the tradeoffs between them.

3.1.1 Successive approximation

Probably the most common technique employed by A–D converters is successive approximation. As the name implies, the input voltage is compared with a succession of reference voltages. Based on each comparison, a new reference voltage is selected (either higher or lower) until within the resolution of the converter the comparison cannot be improved. This technique is similar to finding the root of an equation by “guessing” a root, plugging it into the equation, and then halving or doubling the guess depending on the result. With each successive guess, the range of excursions to the next guess is itself halved or doubled, until the answer is close enough (sufficient resolution). Table 3–1 shows a successive approximation sequence of a 5-bit A–D converter that settles on the number 6.

Table 3–1. Successive approximation sequence.

Binary Output	Description
11111 >	Think of the process as removing
01111 >	calibrated weights from a scale
00111 >	balance—five weights, each
00011 <	weighing half of the next higher
00111 >	weight. When removing a weight
00101 <	tips the scale (<), then put it back
00111 >	on and remove the next lower
00110 =	weight, until removing any lower
	weight causes the scale to tip
	to “<,” or the scale balances (=).

This type of A–D converter is used in applications where sampling at less than 1 MHz is sufficient. It is considered a moderate-to-high-speed converter. Successive approximation takes time, but high resolution can be obtained. Commercially available monolithic IC’s up to 16 bits are common. The higher the resolution, the more conversion time is required (more voltage comparisons to do), and longer amplifier settling time is necessary to minimize amplifier dynamic effects.

3.1.2 Integration

Integrating A–D converters count pulses for a period proportional to the analog voltage input level. The longer a pulse train is counted, the higher the integration value (of the pulse train) will be. When the integrated value rises to match the value of the input signal, the pulse train stops. A counter that has been counting the number of pulses now freezes, and this value is the digital output of the A–D converter.

Dual slope integration involves integrating the analog voltage input for a predetermined time. A reference input is then switched into the integrator and integrates "down" to zero (where it started). The time it takes for the second (down) integration process is proportional to the average of the analog input voltage over the period of the first integration. A digital pulse train pulses over the second (down) integration period and a counter keeps track of the number of pulses. The resulting number is the digital output and is proportional to the analog input voltage. The advantage of dual slope over a single slope integrator is that the dual slope increases accuracy and cancels out temperature effects contributed by resistor and capacitor time constants. It does this at the expense of requiring more control logic.

For example, in figure 3-1 three signals are shown: S_1 , S_2 , and S_3 . The S_1 signal is the smallest, so it integrates up to the smallest level in time, T_1 . When the reference input is switched in at T_1 , the counter is started, and all three signals integrate down at the same rate. The S_1 signal reaches zero first (at point C_1), where its counter terminates. Obviously, if the counter terminated at C_2 , its value would be greater—indicating that S_2 is larger than S_1 .

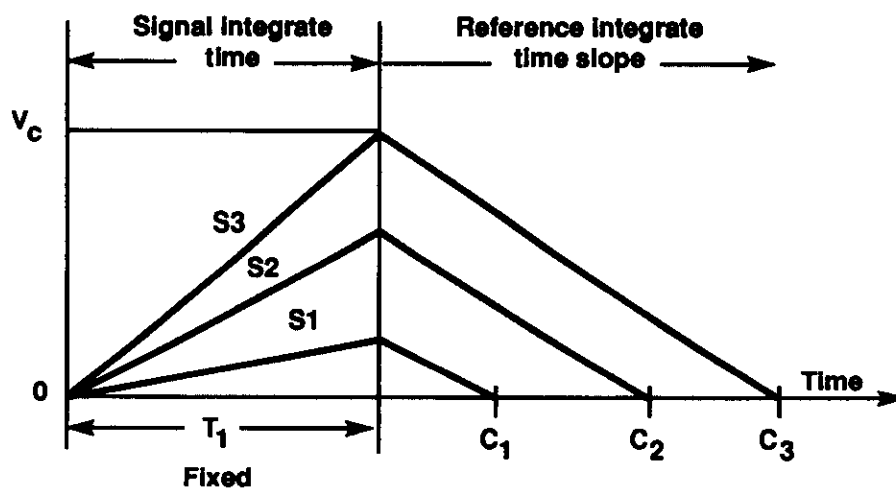

910770

Figure 3-1. Dual slope integration analog-to-digital converter.

Very high resolution data can be obtained at moderate speeds and low cost using this technique. Multiple integration cycles can improve the resolution and accuracy at the expense of speed. The integration process reduces noise at frequencies whose periods are shorter than the signal integration time (higher frequencies). A sample and hold is not necessary.

3.1.3 Multiple comparator (flash) converter

This type of A-D converter is the fastest because the conversion takes place combinationally (unclocked) all at one time. It does this by using many voltage comparators simultaneously. In a true flash converter, $2^n - 1$ comparators are used, where n equals the number of bits in the A-D output. Each comparator is set for a different level and graded in equal divisions from the minimum to maximum acceptable input voltage. All of the comparators with references below the input voltage will indicate HIGHER and the comparators with reference voltages above the input voltage will indicate LOWER. It is like reading a thermometer, where the mercury is seen at each degree below the indicated temperature and no mercury is seen at each degree above the indicated temperature.

The output of each comparator is fed into a priority encoder that converts the decoded inputs to an encoded binary output. The priority encoder requires $2^n - 1$ inputs and n outputs. This process requires many accurate voltage comparators and gates for the usual case where $n \geq 8$. It is very fast, however, because the conversion happens at once.

Figure 3-2 shows a simple example. Here, $n = 2$. So $2^2 - 1 = 3$ comparator stages are required. An extra comparator is used to indicate overrange.

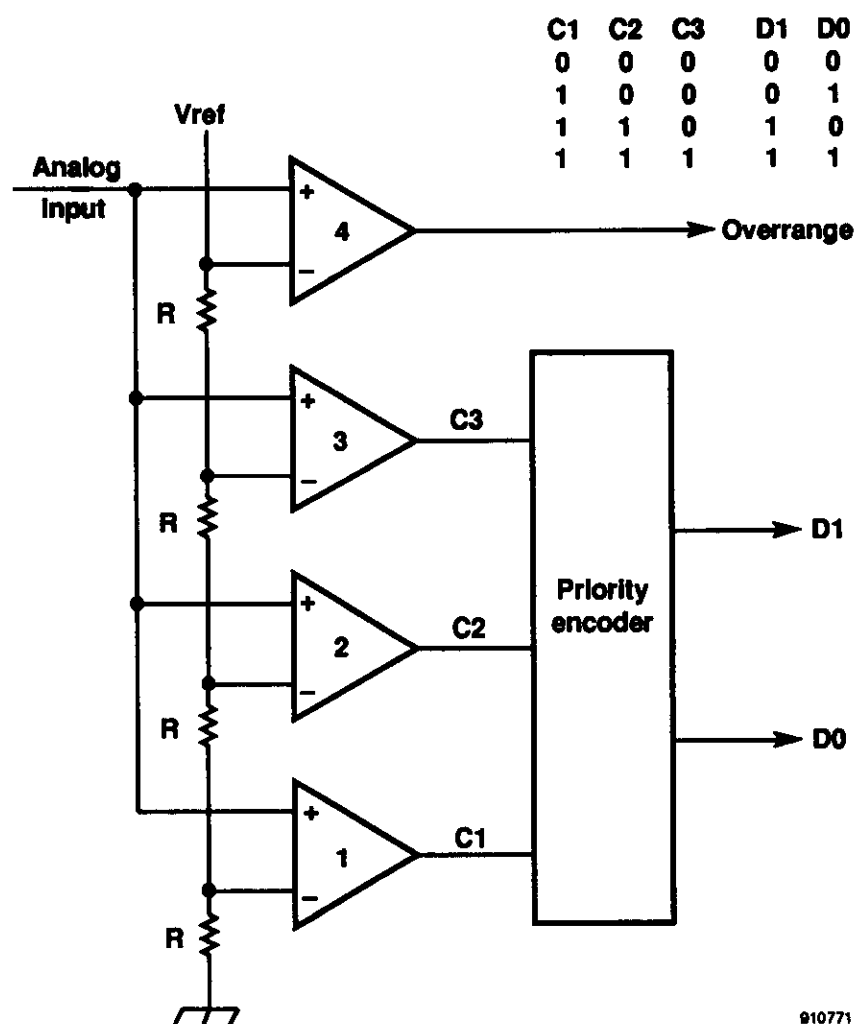

Figure 3-2. Simplified 2-bit flash converter.

Flash converters are used when high-speed acquisition (hundreds of MHz's) is required, but limited resolution is acceptable. Many manufacturers combine techniques to compromise between resolution and speed. For instance, the most significant 8 bits may incorporate flash conversion. The result is converted to analog for subtraction from the original input voltage, which is then fed into another 4-bit flash converter. The resulting 12-bit output is "flashed" in two steps (8 bits plus 4 bits). This "dual-flash" converter has the speed advantage of the full-flash converter while limiting the number of comparators and gates required ($2^{12} - 1 = 4095$ comparators for the full flash as opposed to $(2^8 - 1) + (2^4 - 1) = 270$ comparators for the dual-flash). Other converters combine a flash stage with a successive approximation stage—a so-called "half-flash" converter.

3.1.4 Tracking converter

A tracking A-D converter tracks the analog input continuously. A binary counter is continuously clocked, and the count either increases or decreases depending on the state of an up-down count control (fig. 3-3). The output of the binary counter is fed to a digital-to-analog (D-A) converter. This D-A converter output is compared with the analog input signal and the difference drives the up-down control. The counter is therefore driven to a count that is proportional to the analog input voltage.

If the slew rate limit is not exceeded, the converter will track within ± 1 least significant bit (LSB). Increasing the clock frequency allows for higher slew rate. Slew rate can also be increased by decreasing the resolution (less numbers to count). The tracking converter does not require a sample and hold circuit, but its slew rate limitations make it unsuitable for multiplexed or high-speed sampling systems (ref. 9).

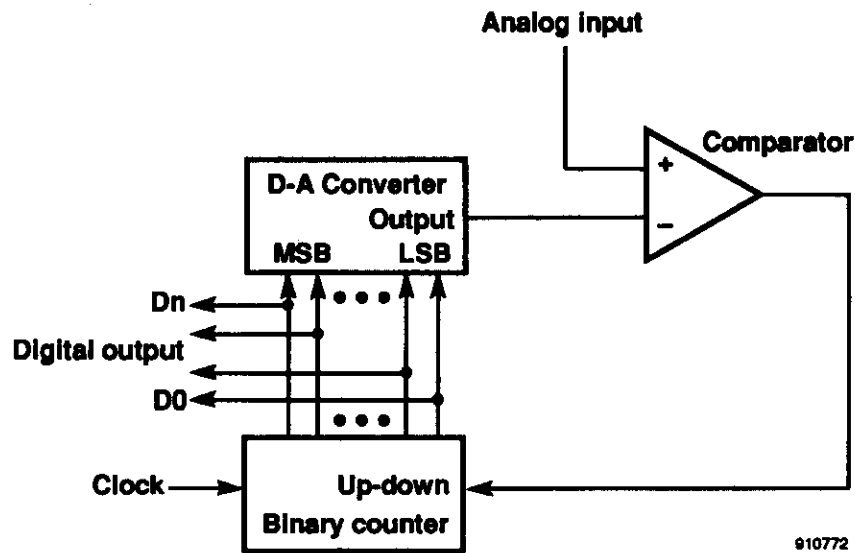

Figure 3-3. Tracking analog-to-digital converter.

3.1.5 Sigma delta converter

A sigma delta converter is an oversampling converter that is gaining popularity because of its ability to provide very high resolution digital output. A traditional A-D converter increases the number of bits used for quantization to yield a better signal-to-noise ratio. A sigma delta converter, however, improves the signal-to-noise ratio by increasing the sample rate while allowing the number of A-D conversion bits to reduce to a minimum.

The name "sigma delta" refers to quantizing the difference (delta) between the current signal and the sum (sigma) of previous differences. Because this comparison is performed at very high rates, the sigma's difference from sample to sample is typically small. Therefore, the difference can be represented with fewer bits of resolution; typically one bit.

The smaller number of bits results in larger quantization noise. However, the converter includes noise-shaping circuitry, which essentially "lifts" or "pushes" noise out from the passband and "drops" it into the stopband. The noise-shaping circuitry can be thought of as a noise modulator. It modulates the noise to another frequency, effectively removing the noise from the band of interest. Traditional modulation schemes move a signal out of a noisy band into a quieter band. In contrast, sigma delta modulation moves the noise to another band, leaving the signal band quieter.

A digital filter then statistically averages the differences and decimates the signal so that more bits, 16 typically, appear at a frequency closer to the Nyquist rate than at the oversample rate.

The sigma delta converter consists of two parts: a sigma delta modulator and a digital filter (fig. 3-4 and sec. 5.2). An input analog signal is fed into the sigma delta modulator. The modulator consists of an integrator, a quantizer (a 1-bit comparator), and a feedback loop through a digital-to-analog converter. Because the A-D converter is only one bit, there is much quantization error (only two digital answers are possible: "1" or "0"). This output is converted back to analog and, containing the quantization error, is subtracted from the original input. Now all that is left is the quantization error, which is then fed through the integrator back into the quantizer. This process is done often (oversampled), and over a large number of samples is statistically averaged by the digital filter. The output of the digital filter is a much higher resolution (16 bits, typically) at a much lower effective sample rate closer to the Nyquist rate.

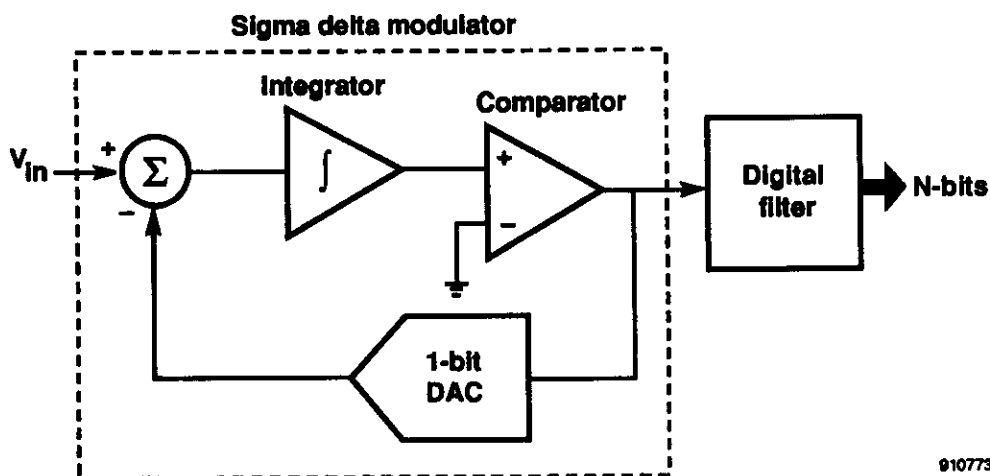

Figure 3-4. Sigma delta analog-to-digital converter.

910773

The sigma delta oversampling scheme shifts most of the conversion burden from the analog world to the better behaved digital world. The high sample rate reduces antialiasing requirements. The analog part of the circuit is greatly simplified because only one bit is quantized; however, the digital part of the circuit is substantial. Only recently has it been practical to incorporate the sigma delta converter on one chip.

The disadvantage of this conversion scheme is that it requires a very high sampling rate, which may be a few hundred times the frequency of interest (64 to 256 times is common). Reference 10 provides additional information.

3.2 Digital-to-Analog Conversion Techniques

Digital-to-analog conversion is less important to aircraft data acquisition systems than is analog-to-digital conversion, discussed in the previous section. The usefulness of converting a digital signal to an analog signal is seen in closed-loop flight control systems, ground-based strip charts, and cockpit instruments driven from a computer system. The area addressed by this volume does not include any of these elements. Therefore, D-A converters are only included to illustrate some of the factors of concern in bridging the worlds of analog and digital signals.

The D-A converters' (DACs') output is *not* truly an infinitely time-varying signal. Because the input values can be discretely quantized, the output levels are also quantized. The result is a time-varying signal that is made up of a series of plateaus (fig. 3-5). Smoothing of the output (filtering) can be done to reduce the serration, if desired, but this adds no new information to the signal. If the serration is unacceptable, then a DAC with more resolution is usually called for—which would decrease the width of the “zone of probability” in the figure.

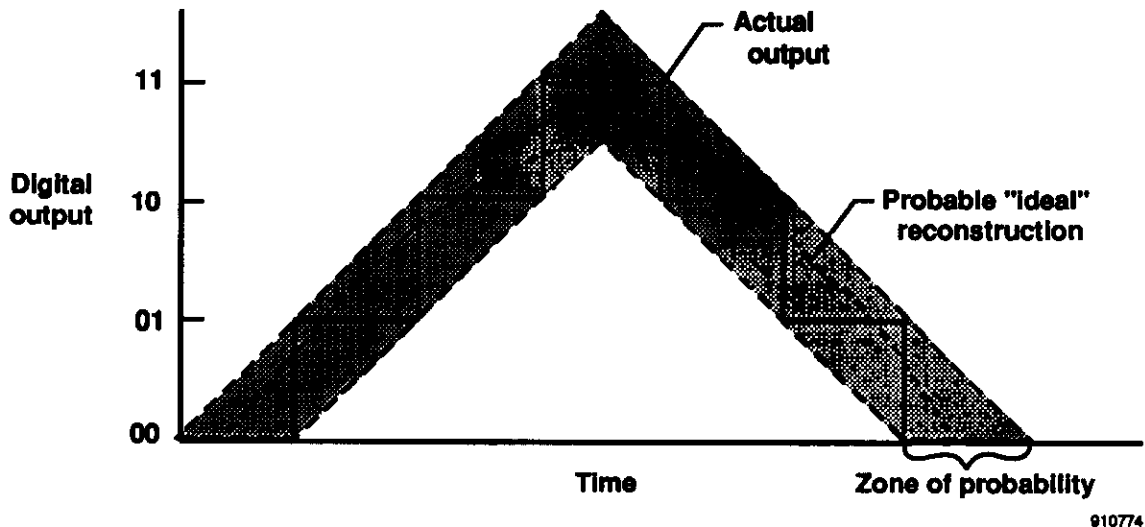

Figure 3-5. Digital-to-analog conversion.

The gain and offset of a DAC refer to the output range covered. For example, if an output requires ± 5 V full scale, then a reference value must be set in the DAC to "calibrate" the minimum digital input at -5 V and the maximum digital input at $+5$ V. The offset is usually included in this calibration. Most D-A conversions are done in a unipolar fashion; that is, the conversion itself is done at 0 to 10 V. Then it is offset down by 5 V (5 V is subtracted from the 0 to 10 V to yield a signal in the range of ± 5 V).

3.3 Digital-to-Synchro Conversion Techniques

Synchros provide an inherently ratiometric conversion method for measuring and controlling precise angular displacements. It is a technique that is very tolerant of noise on the signal inputs as well as voltage drops between the transducer and converter. The synchro is a simple rotary transformer where the relationship between its primary (rotor) and secondary (stator) is controlled by a shaft position. The voltage induced in the stator varies as a function of shaft angle. Resolvers are a subclassification of synchros and differ only in the way the rotor and stator are wound. Synchro-resolver devices have been in use and continually refined for over 40 years and are very reliable.

Synchros are often used to drive pilot instruments, such as radio magnetic indicators (RMI's). In figure 3-6, its basic operation is as follows: a digital word is presented to the digital-to-synchro converter. This digital word is transformed into its sine and cosine values (the so-called resolver format). These signals are converted into the synchro signals S_1 , S_2 , and S_3 through the use of a Scott-T filter. The synchro signals are then amplified to provide the drive necessary by the synchro device. The synchro device reacts to the phase relationship of these three signals in relationship to an alternating current (AC) reference voltage, V_{ref} , and assumes the appropriate angular displacement. Reference 11 gives an example implementation.

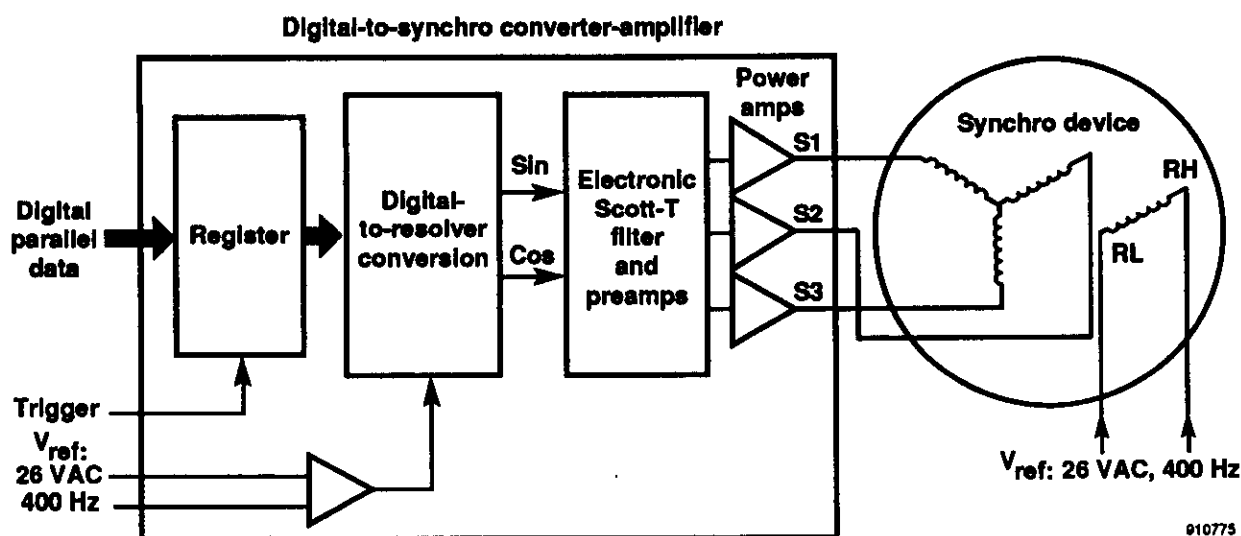

Figure 3-6. Typical digital-to-synchro system.

As a note of caution, the synchro is, as indicated before, a nearly instantaneous angular indicator. But an indicator needle does possess inertia. If the digital value takes a sudden jump in value—indicating a jump of several degrees (for example, 180°)—it is possible to put a synchro indicator into an infinite spinning mode, damaging the instrument. The way around this problem is to calculate the difference between the last commanded angle and the next commanded angle. If the angle is too great, instead pass out a lesser angle and “sneak up” on the desired value. In other words, control the slewing rate.

3.4 Synchro-to-Digital Conversion Techniques

Of more interest to data acquisition systems than digital-to-synchro conversion is synchro-to-digital conversion. This phase difference-to-digital conversion is not sensitive to amplitude variation. However, zero crossing points must be kept in the correct phase. Attention must be paid to noise reduction and setting the maximum tracking rate (rps).

As many cockpit instruments are controlled by synchro-resolver drivers, tapping into these signals with a synchro-to-digital converter can make the pilot displays available to the digital data acquisition system. However, as is increasingly common in flight test, if onboard flight computers are initially controlling these displays by way of digital-to-synchro converters, then it's logical (reduces possible error sources) to feed the digital controlling signal directly into the digital data acquisition system.

3.5 Conversion Process Considerations

3.5.1 Sample and hold

Because an analog-to-digital conversion process is not instantaneous, the analog voltage level must be held constant while the conversion is in progress. This is accomplished by a sample-and-hold (or track-and-hold) stage. The longer the converter takes to perform its conversion, the longer the sample-and-hold stage must hold its value. This holding stage is a charge held by a capacitor (fig. 3-7). The two operational amplifiers (op amps) buffer the holding capacitor from the input and output, each providing unity gain. The “mode control” determines whether the analog switch is in the “sample” (switch closed) or “hold” (switch open)

mode. In comparing the use of small as opposed to large capacitors, a small capacitor will respond more quickly to input changes (higher "slew" rate), whereas a large capacitor will discharge in hold mode more slowly (exhibit less "droop") in response to leakage currents. The optimum capacitance will respond quickly enough for a given signal bandwidth and droop less than one half the resolution of a bit.

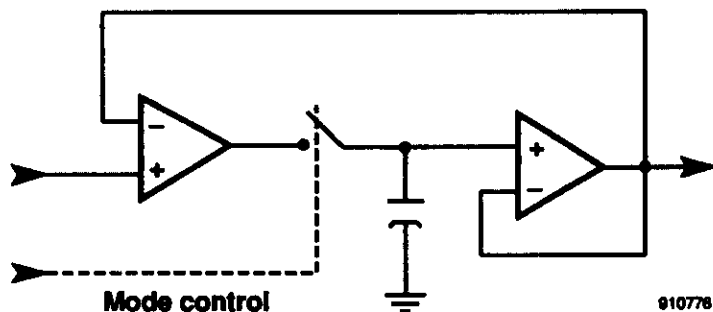

Figure 3-7. Sample and hold circuit.

When the analog input does not change by more than one-half LSB during the conversion, a sample-and-hold stage is not required. Because this puts a constraint on the bandwidth of the signal that can be applied to the converter, most A-D converters have a sample-and-hold stage.

3.5.2 Presample filtering

Presample filtering is used to prevent aliasing of a signal, as described in the next section. It is also used to eliminate a steady-state level (eliminate DC offset), thereby increasing the measurement sensitivity by not requiring a small variation to "sit on top of" a large DC voltage. The measurement window can be scaled to the limits of the expected variation.

3.5.3 Antialiasing filtering

The antialiasing filter prevents high-frequency noise from being sampled by the A-D converter. High-frequency data sampled at too low a rate cause a false reconstruction, or aliasing, when the data are analyzed. The term "alias" means to masquerade as something else. The reconstruction of an aliased signal makes a higher frequency signal masquerade as a lower frequency. This is analogous to viewing a rotating fan by strobe light. Under certain conditions, the fan blade will appear to be stopped, or even to be going backwards, because the eye perceives a masqueraded motion from too slow a sampling rate. In data acquisition, then, it is important to attenuate frequencies above the expected data region *before* the signal enters the A-D process.

Figure 3-8 (also fig. 88 in ref. 1) shows an 8-Hz signal that is sampled in various ways. For clarity, the signal is shown four times, with dotted line curve reconstructions described as follows. In the figure, curve 1 shows an 8-Hz signal being sampled at exactly twice the signal frequency. However, the sampling is in phase with the zero crossover, and thus appears to be a DC signal of zero amplitude. Curve 2 also samples at twice the signal frequency, but the sampling has shifted phase by 90°. In this case, the signal is reconstructed with the correct frequency and amplitude. Intuitively, sampling at any other phase angle (for instance, curve 3) yields a reconstructed signal of the correct frequency but at too low an amplitude and incorrect phase.

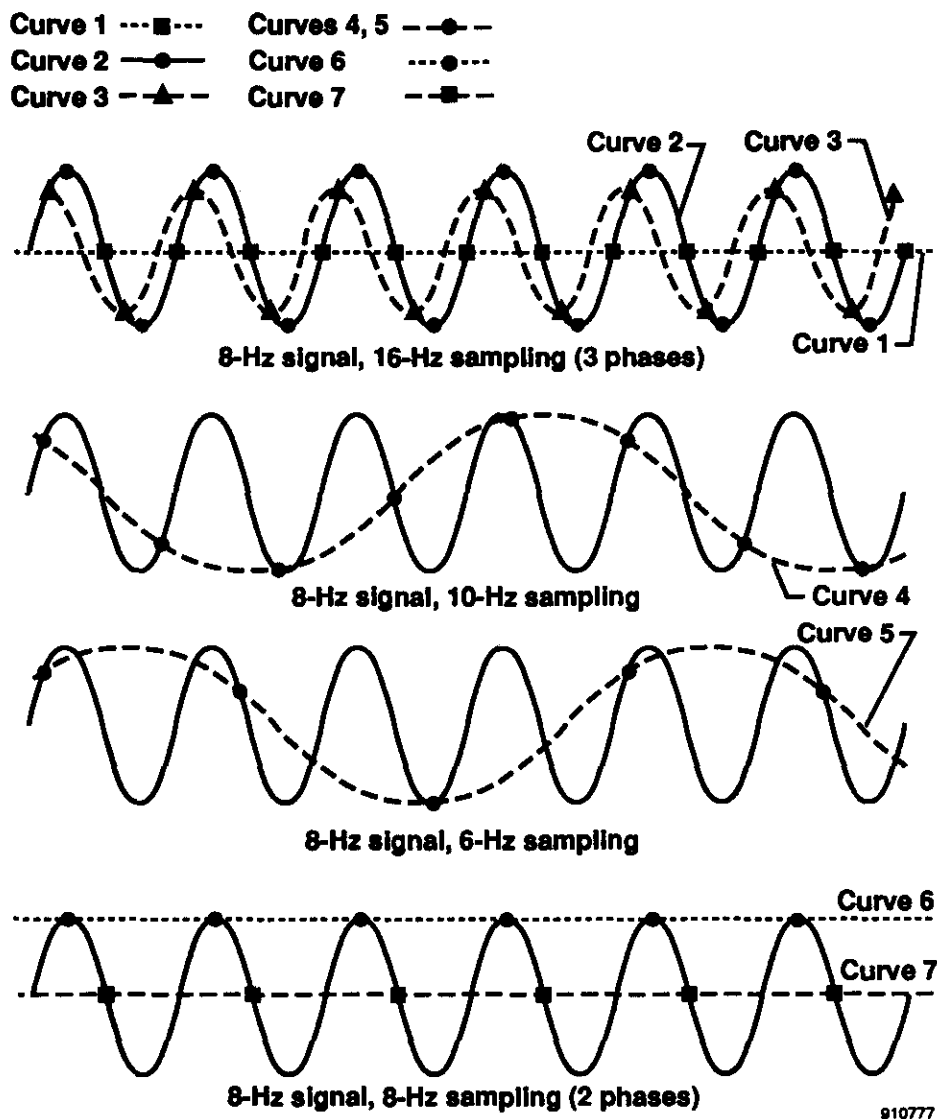

Figure 3-8. Sampling data.

Curve 4 shows an 8-Hz signal that is sampled 10 times/sec. The reconstructed signal appears to be 2 Hz. Note the relationship $10 - 8 = 2$. This relationship can be compared to a beat frequency oscillation, where a resultant frequency is the sum and difference of two frequencies "beat" against one another. In curve 5, an 8-Hz signal sampled at 6 times/sec also yields an apparent 2-Hz reconstructed output ($8 - 6 = 2$). Sampling *at* the signal frequency yields an apparent DC output of arbitrary amplitude ($8 - 8 = 0$).

By using this differences idea, a sampling rate less than the signal frequency yields an apparent (aliased) output of less than the true (desired) output frequency at arbitrary phase. Sampling *at* the signal frequency yields a DC output of arbitrary amplitude, as illustrated in curves 6 and 7. Sampling *above* the signal frequency will also alias an output at less than the desired output, *until* the sampling frequency exceeds *twice* the signal frequency. What is magic about twice the signal frequency? Sampling at a higher rate gives redundant information about the signal, providing information about the signal that will prevent reconstruction at a lesser, or aliased, frequency. This two times frequency is called the Nyquist frequency, and signals should never be sampled at less than this frequency.

Aliasing can occur when a time-varying signal is sampled at a rate less than or equal to two times the highest frequency signal, or the Nyquist frequency. In practice, sampling rates of four to five times the frequency of

interest are commonly used to minimize loss of amplitude. Refer to figure 3-8, curves 1 and 3, for examples of diminished amplitude. The figure shows sampling *at* the Nyquist rate on different phases, but amplitude and phase change can be seen at higher sampling rates, too. Figure 3-9 shows a signal sampled 10, 5, 3, and 2 times/cycle. As the sample rate decreases, the reconstruction (solid lines) becomes less accurate. If the peaks are never sampled, the amplitude will appear diminished. There is a diminishing return in sampling > 5 times/cycle. Note that there is very little difference between sampling 5 and 10 times/cycle.

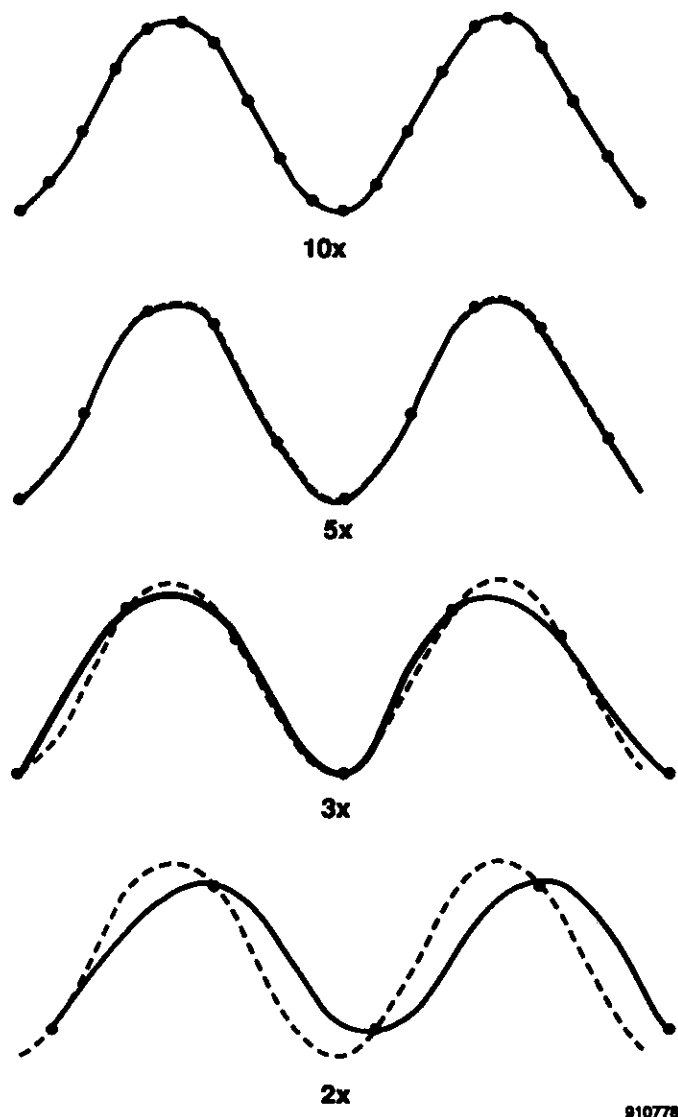

Figure 3-9. Comparison of different sampling rates.

The term used previously was “signals,” not “the signal of interest.” Signals present that are higher than the signal frequencies of interest must be removed prior to sampling (using presample or antialiasing filters), or else the sampling rate must be increased to at least a Nyquist level for these high frequencies. This latter technique is called over-sampling. Once a signal has been sampled, it is impossible to know what is aliased and what is true.

3.6 Process Error Sources

Offset and linearity of A-D converters can be affected by several factors. The most important factor for the instrumentation engineer is temperature. If the output of an A-D converter for a given input changes with

temperature, then this factor must be taken into account in calculating overall instrumentation system accuracy. Calibrations must be done for each temperature, or else the system accuracy must be degraded to allow for the full "window" of calibrations (fig. 3-10). Unless temperature corrections are to be applied to the data, the accuracy of a reading must allow for the possibility that the reading was made at any of the full range of temperatures that the system may see. And the temperatures that the sensor sees might be different from the temperature that the A-D converter sees.

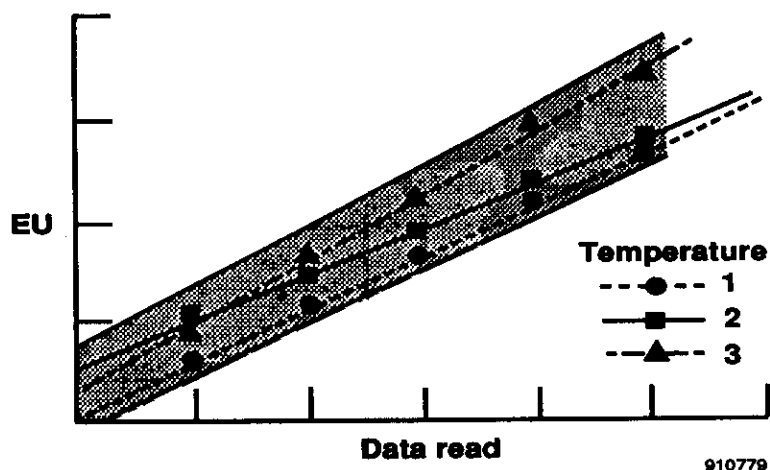

Figure 3-10. Temperature effects on a calibration.

If the response (transfer function) of an A-D converter is nonlinear, then a more complex calibration must be applied to the data when converting it to engineering units. Many systems, particularly real-time systems, do not provide for nonlinear calibrations. In those cases, the overall system accuracy is degraded because the window must be opened up until all points on a curve fall within the "fat" straight line (fig. 3-11).

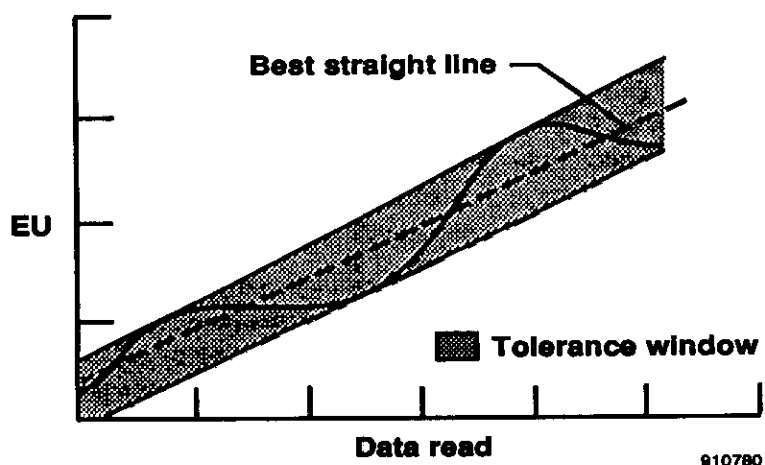

Figure 3-11. Tolerance of best straight line fit for nonlinear data.

It is rare to find A-D converters in aircraft systems using more than a 12-bit resolution unless the converter is at the sensor. The higher the resolution, the more sensitive it is, which makes it more difficult to separate the signals from the noise. The farther the sensors are from the A-D converter, the more opportunity noise has to enter the signal path. For example, a 12-bit D-A converter has a resolution of 1 part (or count) in 4096. If full scale (4095, or 12 "1's") is 5 V and minimum scale (0000, or 12 "0's") is 0 V, then each count is $(1/4096) * (5 \text{ V}) = 1.22 \text{ mV}$. If induced noise in the system is $\pm 3 \text{ mV}$, then $(3 \text{ mV}) / (1.22 \text{ mV/count}) = \pm 2.46$

counts can be attributed to noise. Because counts are discrete (there is no such thing as a fraction of a count), this rounds to ± 2 counts of noise. So when reading the count value corresponding to the input signal, the least significant bit is providing no useful information, and the second-to-least significant bit is providing only some information. Figure 3-12 illustrates this graphically.

The (true) signal level is assumed at 4 counts, and the region of uncertainty is shaded around it (± 2.46 counts). Then successive resolutions are assumed in succeeding columns, and the circled values are the counts reported corresponding to the endpoints of the uncertainty range for that resolution. No new information is obtained after 11 bits of resolution. Going from the 10th to the 11th bit narrows the range of uncertainty, but going from the 11th to the 12th bit does not refine it further.

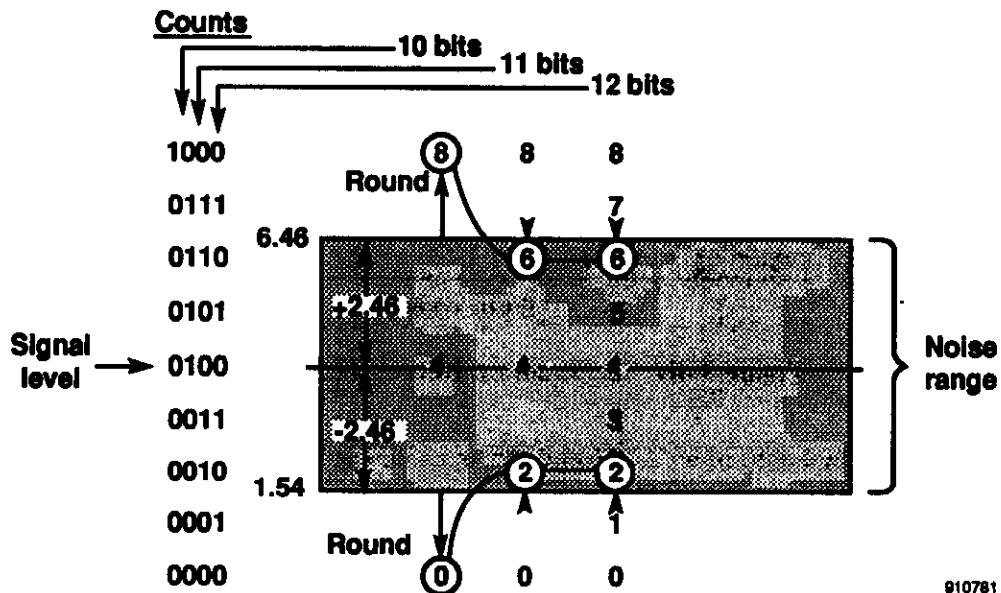

Figure 3-12. Uncertainty as a function of resolution.

If the uncertainty in a reading is greater than the resolution (in this case more than twice as much), then reading the value to its full resolution has little meaning. This is similar to a trap that is often fallen into when reading the results of an electronic calculator computation, where the resolution of the calculator often exceeds the meaningful (significant) resolution of the computation. For example, if in computing $2 * 2$, 4.0000001 were reported, the .0000001 would be mentally discounted as irrelevant to the computation.

By blindly increasing the resolution of an A-D converter, the quality of the data is not necessarily improved. If the uncertainty of a measurement is great, a point is reached where added resolution contributes nothing to the value of the reading. In fact, it frequently obscures the meaning by creating more data to sift through. Misunderstanding the difference between accuracy and resolution is a common falling in instrumentation work.

See reference 12 for further information about conversion processes.

4 DIGITAL TRANSDUCERS

4.1 Transduction Techniques

What constitutes a digital transducer? Generally, any transducer that produces a digital output can be considered a digital transducer. But where do you define the output? If the fundamental operation of the transducer depends on having a digital output, it is a digital sensor. In many cases, however, the fundamental output may be frequency, phase angle, or even voltage, but the sensor box outputs only digital. The conversion has taken place inside the digital sensor box. In this discussion, a digital transducer is a transducer that can be quantized digitally by use of a counter. This includes coded disk, variable frequency, and pulse devices.

4.1.1 Coded disks

Probably the oldest digital transducer is the encoded disk. A disk is divided radially into sections, where each section can be read as a binary number (fig. 4-1(a)). Originally, the reading process was mechanical. Raised bumps displaced a rod that mechanically turned on (or off) a switch. Depending on the number and placement of bumps in a section, different binary numbers that identified the angular placement of the shaft could be read or encoded.

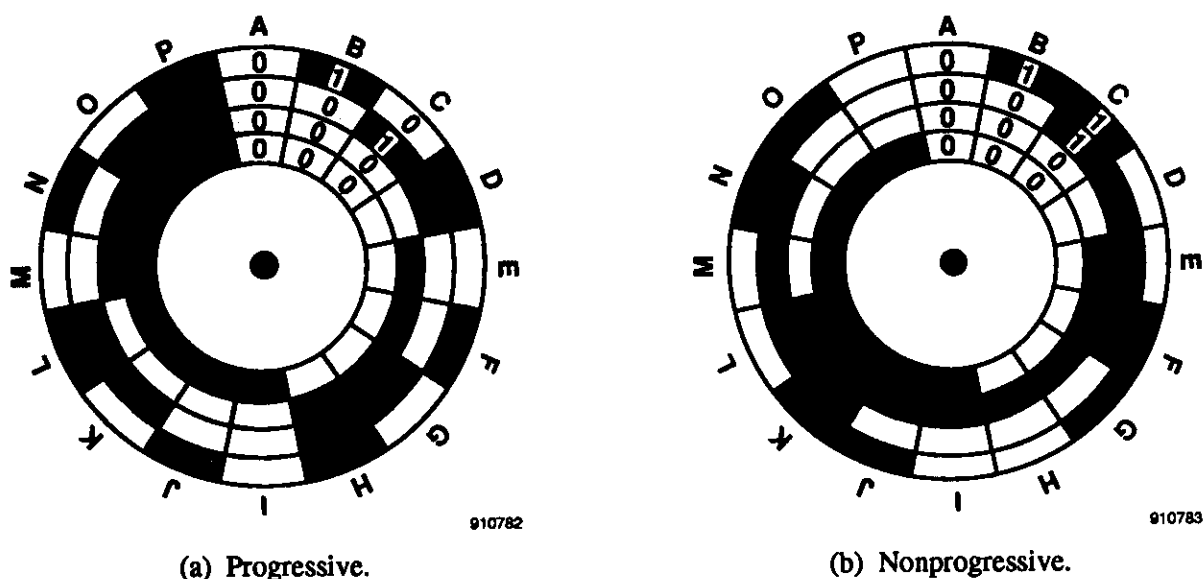

Figure 4-1. Encoded disks.

Another coded disk uses electrical contact rather than mechanical displacement to encode a binary number. The presence or absence of metal in different areas of the section causes electrical contact to be made (or not).

The most modern coded disk is the optical shaft encoder. The sections are broken down into opaque areas and transparent areas. As the shaft rotates, individual light beams are detected by photocells (if transparent) or not (if opaque).

In figure 4-1(a), transitioning from one section to the next may give erroneous numbers not matching either section. For example, in transitioning from section H to section I (fig. 4-1(a)), the encoded number changes from 7 (0111) to 8 (1000). Because the transition of each of the four numbers is unlikely to be completely synchronous (simultaneous), any output combination may be temporarily read—for example, 1111, 1001, 0110. This is similar to a nonsynchronous logic ripple counter, which may yield glitches when counting as the number settles out. By proper use of nonprogressive coding (fig. 4-1(b) and sec. 4.1.2), this problem can be eliminated.

4.1.2 Variable frequency

Some sensors convert measurand information to frequency variations. With a resonant piezoelectric pressure transducer, varying pressure on a crystal causes its resonant frequency to vary, or shift. This frequency is converted to a digital value proportional to the frequency. An rpm indicator is another example of a variable frequency sensor as rpm's are a measure of the frequency of revolution.

One way of performing this conversion is to count zero crossings in a signal for a specified amount of time. The number counted will be proportional to the frequency (fig. 4-2).

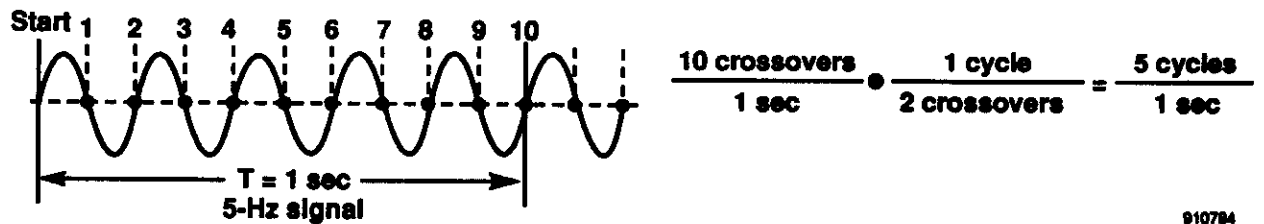

Figure 4-2. Zero-crossing count to determine frequency.

4.1.3 Pulse techniques

Many physical phenomena are discrete. For instance, the process of counting particles is inherently digital, but the detector may only be able to detect one particle at a time. Therefore, for a particle count to be made, a counting quantizer must be used. The quantizer may be simply a progressive counting register that activates when a pulse arrives. However, if several particles arrive in close proximity to each other, the detector may count them as one particle. The solution to *this* problem is not straightforward.

4.2 Coding

Sometimes it is important to code a number sequence so that it is straightforward to read or to use in an equation. Other times, an encoding scheme would inherently increase the potential for false readings, as mentioned in the section on encoded disks. This section discusses different coding techniques.

4.2.1 Progressive codes

Progressive codes, the most common type of coding in modern digital transducers, progress in a numerical up or down count order (fig. 4-1(a)). This type of coding works well with computer input, because only a simple calibration (by way of a table lookup or linear transformation) is needed. For instance, if a digital transducer counts from 0 to 1023 (10 bits), and this range corresponds to -3 to 3 lb/in² differential, then the simple calibration of

$$\frac{3 - (-3)}{1023 - 0} \times (\text{counts}) + (-3) = \text{engineering units in lb/in}^2 \text{ differential}$$

can give the desired result. Or a 1024-point lookup table could be made with counts as the input and lb/in² differential as the output. In either case, the calibration curve is monotonically increasing. As the counts increase, so do the lb/in² units.

4.2.2 Nonprogressive codes (Gray)

Nonprogressive codes do not progress in a numerical up or down count order. The most common nonprogressive code is the Gray code. The important feature of this code is that in moving from one count to the next, only one bit position changes state. This is useful in preventing "glitches" (momentary output transients yielding incorrect values). If the worst glitch that could occur is to toggle between the original state and the new state, which is only one LSB, then the effect on the system would be minimal. If, however, several bits were to rollover during the transient, as with a progressive binary upcount like 0111 to 1000, then several intermediate counts could be seen during the transition, depending on the relative speeds of bit transitions. See figure 4-1(b) and table 4-1 for an example of a Gray code count. Only one bit changes between any two adjacent rows.

Table 4-1. Gray code.

Description	Code counts	
	Gray (nonprogressive)	Binary (progressive)
For lines (1), (2), and (4),	a 0000	0000
if the numbers are folded	b <u>0001</u> (1)	0001
at line (1)—line a	c 0011	0010
overlying line d and	d <u>0010</u> (2)	0011
line b overlying line	0110	0100
c—a perfect match of	0111	0101
the least significant digit	0101	0110
occurs. Also, folding the	<u>0100</u> (4)	0111
numbers at line (2) matches	1100	1000
the least significant two	1101	1001
bits while folding at (4)	1111	1010
matches the least significant	1110	1011
three bits. Gray code continues	1010	1100
in this way for as many bits	1011	1101
as needed.	1001	1110
	1000	1111

Nonprogressive codes are important in mechanical devices such as shaft encoders. Here mechanical misalignments cause problems when state changes require simultaneous switching. Misalignments can be measured in several tens of msec. In modern electronic logic circuits, however, outputs can be synchronized so that all bit changes are presented to the output stage at virtually identical times. Clocking can be synchronized to strobe the output to the next stage after the output has settled.

The only place that nonprogressive codes are found in modern flight testing work is when old mechanical devices have been emulated with more modern electronics. An example is an altitude reporting transponder, the standard for which has existed for many years—from when most transponders were driven by pressure-sensing rotating drums. For computational purposes, this kind of coding requires an extra level of decoding so that numerical computers can work with the data.

Gray coding is the same technique used in reducing combinational logic truth tables into Boolean equations known as the Karnaugh number diagram technique. It can be viewed as successively unfolding a piece of paper horizontally and vertically. Each unfolding adds a binary digit to the left and the existing numbers are mirrored into squares of the segment just opened. Figure 4-3 shows two different unfolding methods. Moving from any square to an adjacent square changes exactly one bit, as with the Gray code.

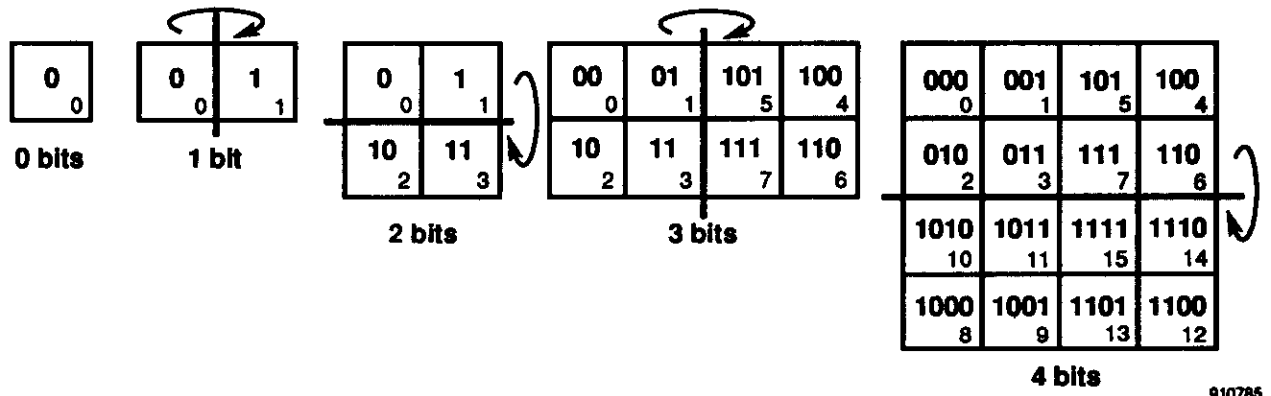

910785

(a) Method 1.

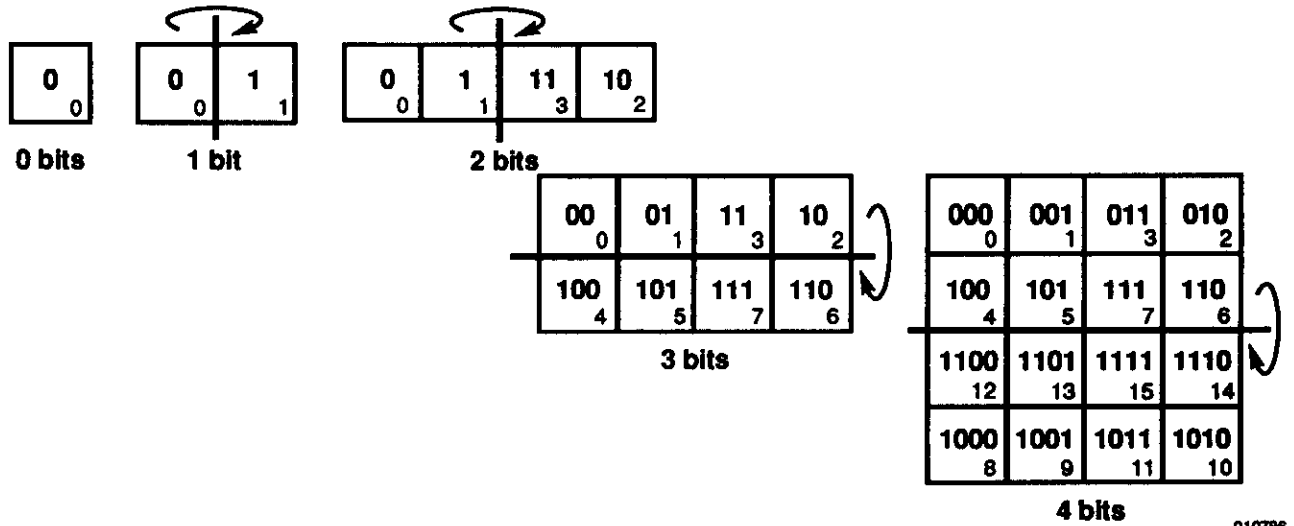

910786

(b) Method 2.

Figure 4-3. Unfolding a Karnaugh number diagram.

5 DIGITAL FILTERING

5.1 Applications and Guidelines

Digital filtering is a computational technique that inputs digitized sampled data and outputs filtered digital data. The reconstructed output waveshape differs from the input reconstructed waveshape according to the definition of the filtering algorithm being applied.

This technique is very common in analyzing flight test data because many of the filters can be applied to raw flight data for analysis. Digital filtering is done completely in the domain of "number crunching"; that is, processing digital numbers typically in a non-real-time postflight environment.

Many filter characteristics that simulate analog filters such as Bessel, Chebyshev, Butterworth, and so forth, can be realized. These and other filters are covered in detail in reference 1.

Digital filters cannot completely replace analog filters in the instrumentation system, however. As discussed previously, because of errors introduced in the sampling process, presample (analog) filters must be used. Presample (analog) filters can be dispensed with in favor of oversampling techniques only if assumptions can be made as to the maximum frequencies present in the presampled system.

Currently, the use of computational digital filters is limited in real-time, onboard data acquisition. However, with the steady advance of digital signal processors, high-speed computation, high-density memories, and so forth, they are increasingly under consideration as part of the flight instrumentation system.

5.2 Time Domain Filters

Figure 5-1 shows the four basic filter types: low-pass, high-pass, band-pass, and band-stop (notch) filters. The ideal filter has the stop band frequency (f_{su} or f_{st}) equal to its corresponding passband frequency (f_{pu} or f_{pt}). The ideal filter also has a unity gain in the passband. In other words, an ideal filter would have vertical "porches" with no transition region. Such ideal filters do not exist, but digital filter implementations approximating the ideal conditions can be implemented far easier than their analog counterparts.

There are two types of digital filters: finite impulse response (FIR) and infinite impulse response (IIR). The following is a very general comparison of these two types. The FIR filters can provide an exactly linear phase-frequency relationship (linear phase delay); the filter time delay is constant in time regardless of the input frequency (constant group delay). The IIR filters cannot have a linear phase delay. However, IIR filter implementations have a much smaller phase delay than FIR filter implementations. The FIR filters are closer to ideal than IIR filters; however, FIR filters are more computationally complex (and therefore slower) than IIR filters and tend to require more hardware.

The FIR filters, therefore, are suitable where high accuracy and linear phase are important. The IIR filters are suitable for applications requiring high-speed and minimal phase delay. In flight testing, where multichannel high-accuracy data acquisition is used, FIR filters have the most application.

Digital filters also provide tighter control of the filter transfer function than do analog filters, and they allow implementation of highly complex filter characteristics. Difficult matching of components frequently required in analog filters is not required of digital filters. Changing software coefficients is much easier and devoid of the realities of component tolerances. Digital filter features of tight control and ease of implementation make possible a much better rejection of signals in the stop band and a much smaller passband gain tolerance (flatter response) than analog filters do. Digital filter performance is also independent of temperature, vibration, and age. The filtering is done by software rather than by hardware as with analog filters.

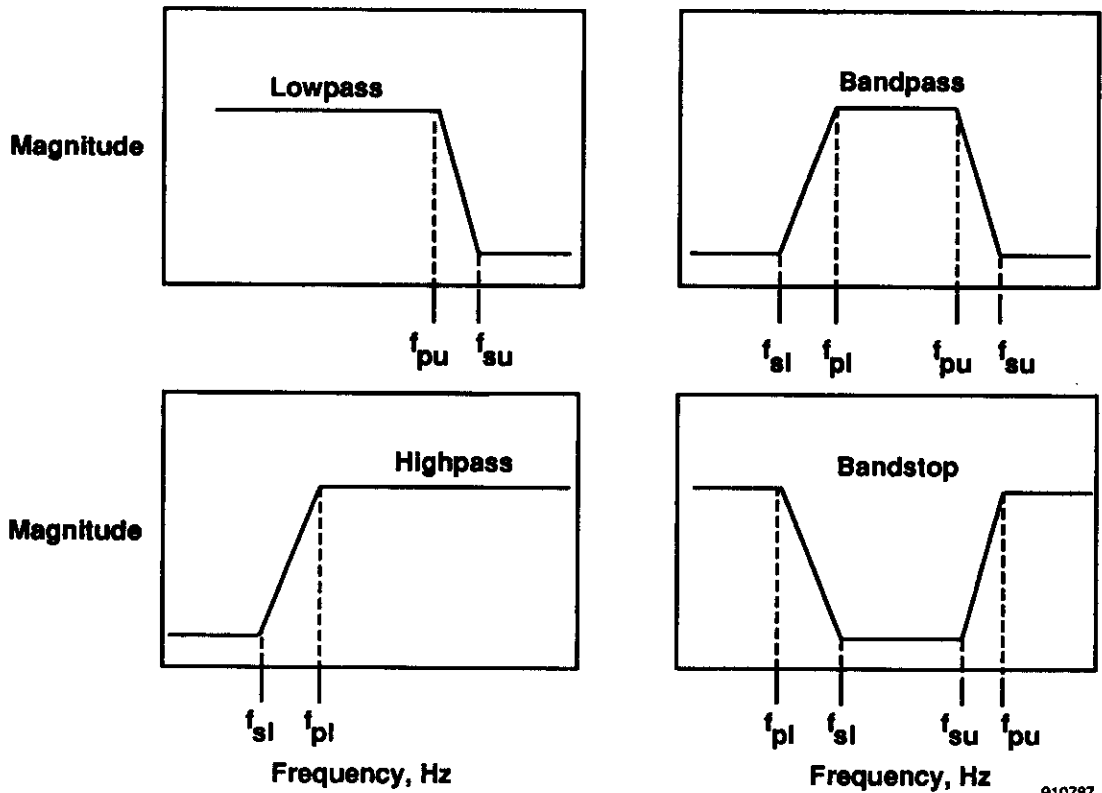

Figure 5-1. Time domain filters.

5.2.1 Nonrecursive filters

Digital filters are nonrecursive if the current output sample is a function of the present and of a few past inputs. Another name for nonrecursive filters is finite impulse response. This type of filter has no equivalent in analog circuitry.

5.2.2 Recursive filters

Digital filters are recursive if the current output sample is a function of present and *all* past input samples. Recursive filters are also known as infinite impulse response. This type of filter is realizable in analog circuitry.

See references 13 and 14 for an indepth mathematical discussion of digital filters.

5.2.3 Switched capacitor filters

A common analog filter in use is the resistance-capacitance (RC) filter. This filter's characteristics can be altered by changing either the resistance or the capacitance of the filter elements. This is accomplished either by removing the filter signal conditioning card from the system and manually replacing the elements, or by remotely switching components by switches, relays, or analog multiplexers. Manual removal is time consuming and disturbs the system. Remote switching typically requires bulky components and therefore lowers the density of circuitry required.

But switched capacitor filters get around many of these problems. The filter operates as an RC filter, where the “resistance” is determined by switching the capacitor in and out of the circuit. Changing the rate of switching changes the effective resistance. The ability of the circuit to store charge is altered by adjusting the clock frequency. Increasing the clock frequency causes a greater conductance (lower resistance) in the capacitor which allows a greater charge-discharge rate. This ability to vary the charge-discharge rate is equivalent to varying a resistor value. Thus, the filter characteristics can be altered remotely by changing the clock frequency, and bulky extra RC components are not required. A more detailed discussion follows.

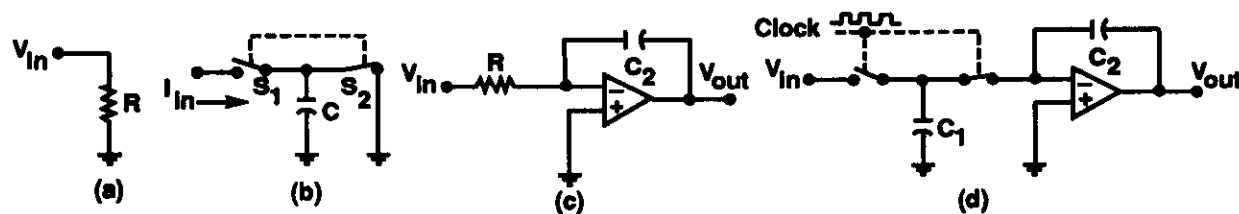

Figure 5-2. Representation of a switched capacitor as a resistor.

The key to understanding a switched capacitor filter is to think of current flow as a function of the charge (Q) flow, though current flow in a resistor is controlled as a function of resistance R . With a simple resistor, as shown in (a) of figure 5-2,

$$I = V_{in}/R \quad (1)$$

Consider the circuit shown in (b) of figure 5-2, where the charge on a capacitor C is controlled by alternatively charging it (by closing S_1 and opening S_2) and discharging it (by opening S_1 and closing S_2). Remember that current through the capacitor is a function of the rate of charge flow Q :

$$I_{ave} = Q/T = V_{in}C/T \quad (2)$$

where T equals the time between successive closings of S_1 (beginning of each charge cycle), defined as

$$f_{clk} = 1/T \quad (3)$$

By rearranging and substituting equations (1), (2), and (3), a resistance equivalent is obtained in terms of capacitance and f_{clk} :

$$R = V_{in}/I_{ave} = 1/C(f_{clk}) \quad (4)$$

So it can be seen that for a given C , adjusting the effective R can be accomplished by adjusting f_{clk} .

In practice, S_1 and S_2 are typically MOS switches, and an active equivalent RC filter is used. In (c) of figure 5-2, a simple low-pass, single-pole, active filter is shown, while (d) shows the same filter with R replaced by the equivalent switched-capacitor circuit.

The switched-capacitor filter is not a panacea, however. It possesses certain DC offset characteristics and high-frequency limitations. The filter is also a sampled filter, making it subject to the same criteria as other sampled systems. Attention must be paid to the Nyquist frequency—in this case running the clock frequency at least twice as fast as the frequency of the signal being filtered. The filter also introduces noise into the filtered output, which limits the signal to an effective resolution of approximately 0.1 percent. Also, introduction of high-frequency square-wave clocks to allow the filters to operate could introduce noise into surrounding analog

lines. But improved designs and their ability to be packaged in monolithic parts along with other elements of signal conditioning makes them of increasing value.

See reference 15 for a discussion of switched-capacitor filters.

5.3 Statistical Filtering

Statistical filtering is the interpretation of data in a distribution sense. For instance, creating a histogram where each column represents the pressure at a particular spacial position or the number of a particular sized particle detected.

There is much interest in measuring aircraft vibration, particularly in clearing an aircraft structurally for different flight envelopes. These vibrations are high in frequency. Typically, the frequencies are modulated on an FM (frequency modulation) carrier and transmitted to tape or ground facilities. If a sampled system is used to measure the frequency, samples would need to be taken at least at twice the frequency (Nyquist theorem) of the measured system. As discussed in section 3.5.3, however, the system should be sampled at greater than this frequency if proper phase and amplitude is to be maintained. In either case, for safety of flight monitoring, this data must be telemetered and analyzed to determine frequency content. The process requires a wide bandwidth for transmission and a computationally intensive activity at the receiving end. If an appropriate statistical filter is applied at the point of sampling, the data may be reduced to reporting just the frequency modes (frequencies and amplitudes) with a considerably reduced transmission bandwidth requirement.

5.4 Data Compression Filtering

The process of compressing data is an act of filtering. The simplest form of data compression filtering is to examine a data parameter and not pass it on if it has not changed from the last time it was sent. This form does not reduce the overall information content. The data can be reconstructed easily with some extra computational capability. The only drawback to this technique is in cases where data are lost as a result of transmission dropout or interference. If the data chose that moment to update their value, and that information is not updated again, then significant errors can creep into the data being analyzed. In short, missing one value that is seldom sent is more significant than missing one value that is frequently sent. For example, an aircraft is not likely to swing its landing gear very often (hopefully, an even number of times)—certainly less often than the aircraft speed changes occur. Sending the gear position updates at the same rate as the speed updates is a waste of bandwidth resources.

Variations on this form of filtering include creating a window to define what constitutes a “change.” For instance, the algorithm might say, “send a new temperature value if it has changed by more than 0.2°F since the last time the value was sent.” In this case, some information content will probably be lost, as with most “normal” filter implementations. But what constitutes a significant change can be defined.

5.5 Pitfalls (Problem Areas) of Digital Filtering

Digital filtering requires much computation. Until recently, computations could only be done in non-real-time (during postflight data reduction). Inclusion of modern digital signal processors (DSP's) on aircraft data acquisition systems requires skills not normally possessed by experienced instrumentation engineers. Fortunately, manufacturers are hiding the mathematical magic and are requiring implementers to input the same design criteria as they did for analog filters (passband frequency, stop band frequency, stop band noise rejection, passband gain tolerance, and sampling frequency). The only addition is deciding the number of coefficients to use, and even this number may be set to a recommended value determined by the rest of the criteria. However, signal processors exist that require the engineer to write the digital filter design code.

It must be reiterated that unless the measurand is oversampled sufficiently (remembering that sufficiency must be determinable), it must be antialias filtered *prior* to sampling or entry into a digital filter.

6 DIGITAL COMMUNICATION

6.1 Technology Choices

There are three basic methods for transferring digital data: copper wire, telemetry, and optical fiber. Each method has its advantages and disadvantages.

6.1.1 Copper wire

This method is the simplest and oldest medium of transfer for digital data. Interfacing to transmission and receiving equipment is simple and straightforward. However, it does have shortcomings. Digital transmission is usually a series of square waves. Square waves can be considered as a collection of an infinite number of sine waves at different frequencies and amplitudes. Cables selectively attenuate higher frequencies. Because the higher frequencies contribute the most to the "sharpness" of a square wave's rise and fall time, the pulses will round off and spread (disperse). At long cable lengths, the round off becomes significant. At high pulse rates, the rounding can cause difficulty in distinguishing closely spaced pulses.

In addition, copper-wired transmission is susceptible to interference from electric and magnetic fields. Twisting wires can minimize magnetic field interference, and shielding the wires can minimize electric field interference. "Crosstalk," or the picking up of signals from adjacent channels, is a frequent result of these fields.

Another problem in copper-wired transmissions can arise if the signal return is "ground" referenced at each end. This is a so-called "single-ended" or "unbalanced" connection. The problem here is that each end of the "ground" is at a different voltage potential because of stray ground currents flowing in the nonzero resistance of the conduction path between the two ground terminations. There are many sources of electric energy in an aircraft. The more sources that are ground referenced to the same conductive medium (typically the skin or frame of a metal aircraft), the more currents are induced. Therefore, there is more voltage difference between any two points, which can significantly cut into the noise margin.

Finally, at longer cable lengths and higher pulse rates, transmission line effects are seen. Discontinuities, or mismatches, in impedances will cause reflections that can significantly distort the pulses.

6.1.2 Fiber optics

Fiber optic data transmission is the most important technical development in data communication in recent years. With it, almost all of the disadvantages of copper-wired transmission disappear. Fiber optics allows for extremely high data rates over long distances and is virtually immune to electrical interference, grounding problems, and static. It is also extremely lightweight.

These are important considerations in aircraft—especially weight and noise immunity. Fiber optics has a few disadvantages, however. Currently, fiber optic transmission requires a change in energy from electrical to optical and back. This change requires additional hardware. More importantly, the optical fiber connections at this stage of development are difficult and require a special skill for use.

Connection techniques have become easier, however. The use of laser diodes lessens connection losses so connection alignments are not as critical.

Instrumenting an aircraft for flight test frequently requires modifications and additions to existing aircraft wiring. A flight test program usually requires modification of the wiring for different phases of testing. Because connections are the single most difficult part of a fiber optic installation, this situation presents difficulties. Fiber connections work best if there *are no* connections. Common practices of bulkhead disconnects in wiring can significantly degrade an optical signal. A single optical fiber should extend from one end to the other because splitting off signals for bus-type connections is tricky.

Today there is little use of optical fibers in “wiring” instrumentation for flight test. Some organizations have experimented with it, abandoning it until the technology of interconnecting systems improves.

Optical fibers are, however, finding use in digital flight control systems, particularly in military aircraft. These installations don’t require most of the dynamic reconfiguring that flight test instrumentation does. The advantages of lighter weight, electromagnetic interference (EMI) immunity, and high data rates win out. However, because these systems must be monitored for flight testing, instrumentation crews are being forced to work with optical fibers.

6.1.3 Telemetry

Telemetry is the broadcasting of digital information by way of radio frequency energy. Its use in flight testing is extremely important. Telemetry provides ground-based evaluators with instrumentation data in real time so that safety of flight parameters can be monitored. It also provides a record of the test flight if the onboard recording device is damaged or destroyed in a crash. In an aircraft without an onboard recorder, telemetry can provide the *only* record of flight data.

6.2 Transmission Timing Choices

6.2.1 Synchronous

Synchronous transmission of data transmits in a regular, predictable, continuous stream. The Inter-Range Instrumentation Group (IRIG) pulse-code modulation (PCM) signals are sent in this manner. The receiving equipment locks onto PCM synchronization word patterns that are unique and not found in the rest of the data stream. Thus, the equipment can keep track of its position in the PCM stream. There are two advantages to this technique. First, with the appropriate PCM sampling system, data are sampled at regular, predictable intervals and work with linear reconstruction techniques using simple computer programs. Second, standard IRIG decommutation equipment can be used to receive and interpret the data.

The disadvantage of this method of data transmission is that for data changing value much slower than the sampling rate, bandwidth is wasted. Synchronous transmission requires *regular* sampling of data as each data parameter is identifiable by its own unique timeslot. Even if a parameter has the same value as the last time it was sampled, it must be transmitted regardless because that timeslot has been assigned to it. Obviously, if much of the data are static, then much redundant data are transmitted.

6.2.2 Asynchronous

In asynchronous transmission, data are transmitted only when there is new information. The signal medium (RF, data lines, and so on) is “dead” between transmissions. During times of high message traffic, the stream may appear to be continuous, but some minimum dead, or “stop” time is proscribed between message words or groups of words. This technique is useful when unnecessary use of bandwidth is to be minimized.

These are two disadvantages to asynchronous transmission. First, each data message must carry label and sample time information to fully identify a parameter or group of parameters. This, as well as the requirement for a certain stop time, increases the amount of time to send data, a drawback if much data require transmission. Second, receiving equipment is complicated because more intelligence is needed to decode the data. Each data word or packet must have its label(s) examined to determine what data it is.

Sometimes hybrid approaches are used. With the F-15 digital electronic engine control (DEEC) system tested at the NASA Ames Research Center’s Dryden Flight Research Facility, data were sent as asynchronous 8-bit bytes (with 1 start bit and 2 stop bits). However, the contents, when constructed, resembled a synchronous

data stream complete with frame synchronizers. This is perhaps the simplest approach in terms of hardware and software required for data sent over wire at moderately slow data rates.

In another case, asynchronous data from a military standard (MIL-STD-1553) data bus (discussed in sec. 6.5.1) was reformatted into a synchronous, frame-synchronized data stream that made use of dummy data words when there was dead time (ref. 16).

6.2.3 Isochronous

Isochronous transmission is data transmitted based on a direct relationship to events being monitored. For example, in helicopter testing, it is more significant to time data relative to the revolution rate of the rotor blade than it is to an arbitrary (and therefore, nonsynchronized) time.

6.3 Communication Format Choices

6.3.1 Serial transfer

Serial transfer is sending digital data one bit at a time. It takes several "bit times" (8, 10, 16, 32, and so on) for a unit of digital information (a word) to be transferred. This form of transfer requires the fewest connections between a transmitting and receiving system, usually only two electrical wires or one optical fiber. Serial transfer saves weight and, in the case of telemetry transmission of data, saves RF spectrum bandwidth. With today's LSI components, it is no more complex than sending data in a parallel (see sec. 6.3.2).

Serial data can be regarded in one of three ways: unidirectional, half duplex, or full duplex.

Unidirectional transmission, as the name implies, is data sent in one direction only. The transmitting end requires no information from the receiving end. It is just "broadcasting" the data to whatever might be listening. This is the mode used when sending telemetry from an aircraft to ground stations or to onboard recorders.

Half-duplex transmission sends data both ways, but only one direction at a time. The best example of this is a two-way radio, where each station can transmit over the same frequency by taking turns. Various standard practices are developed to know whose turn it is to transmit. The same is true of half-duplex data transmission. This form was very common in the early days of radio teletype, computer-teletype links, and, currently, shared data bus connections like MIL-STD-1553 (sec. 6.5.1).

Full-duplex transmission sends data both ways at the same time. A telephone connection is a good example. Both parties can converse simultaneously, although with most humans this would make little sense. However, it does relax protocol requirements. A talker can be interrupted. In data communications, more than interruptions can be made. Data can flow in both directions at the same time, and can keep each end informed of the other's comprehension. (Is the receiver's buffer full? Has it detected an error?) Full-duplex connections make the most sense in point-to-point connections between computer systems. Also, they are the most convenient form in terminal-to-computer connections, and are the most common form in use. In its simplest form, another pair of wires is added to allow information to flow back, as with ARINC 429 discussed in section 6.5.2.2. In a more complex form, multiple frequencies and phases over the same pair of wires are used. Appropriate filtering at each end separates each frequency into the appropriate interpretation of digital data. This is how telephone full-duplex MODEM's function.

6.3.2 Parallel transfer

Parallel data transfer is the fastest way to transfer digital data. An entire digital entity, or word (for example, 8, 10, 16, 32 bits), is sent at one time. If several words are required to make up a message, then this type of

transfer is called word serial as only one word is sent at a time. Theoretically, a parallel transfer can be n times faster than a bit serial transfer, where n is the number of bits in the word.

Parallel transfer is discussed only in relation to wired connections. A parallel transfer in telemetry would require an extremely wide bandwidth, or range of frequencies, and an enormous amount of transmitting and receiving equipment to effect a parallel signal path.

There is a lack of standards in parallel connections. Printer ports use a "Centronics" standard (unidirectional), and many computer backplanes are using bus standards (VME, MULTIBUS, G-64, and so forth).

In summary, parallel connections offer the fastest, least protocol-complex data transfer while adding interconnection complexity (more wires) and weight to the solution.

6.4 Data Formats

6.4.1 Timing and synchronization

The most common method of data formatting in flight test is PCM. Data are sampled and sent in a bit serial fashion on a regular, predictable, timed cycle. To decode the information, synchronization words are sent to mark the beginning of a group, or frame, of information.

The location of a word relative to the synchronization words determines the significance, or label, of that word as opposed to each word having a label attached. This technique is simple to encode and makes efficient use of bandwidth, wasting only those words required for synchronization. However, it is difficult to decode without using commercial decoding equipment, and requires data to always be sent. The data are sent even if the information has not changed from the last transmission, resulting in wasted bandwidth.

The PCM transmission following IRIG standards is a unidirectional transfer. If the receiving station detects questionable data, it has the option of keeping it or ignoring it. It cannot direct the transmitter to retransmit it. Because the detection of errors is in the form of recognizing the synchronization words at the proper time, if it doesn't see what it expects, then it must assume that the entire last frame of information is suspect (see ref. 1).

6.4.2 Error detection and correction

6.4.2.1 Parity bit

The simplest form of error detection is the parity bit. The transmitting device computes a parity bit for each data word sent and combines the bit with the data word to form a transmitted word. The receiving device receives this word; performs its own computation of what the parity bit should be; compares it to the transmitted parity bit; and, if different, shows that an error has occurred.

The calculation is a simple one. The word, being binary, consists of 1's and 0's. Count the number of 1's that occur in the word (bit position is not important), and see if there are an odd or even number of 1's. If the system is designed to use "odd parity," then the total number of 1's in the transmitted word (including the parity bit) must be an odd number. The parity bit is then set to either 1 or 0 accordingly. An "even parity" system adjusts the parity bit so that an even number of 1's are transmitted. Either way, this system will only detect an odd number of errors. An even number of errors will cancel each other out and the error will go undetected. Note also that there is no way of determining *where* the error is in the word, only that an odd number has occurred. Therefore, this is an error detection, but *not* an error correction, scheme.

6.4.2.2 Error correction code

Error correction codes (ECC's) are clever mathematical techniques for not only determining that errors have occurred, but also for learning in which bits they have occurred. Because this is binary data, knowing that a particular bit is in error infers that the opposite logic level is the correct data; thus the error can be corrected.

A simple, effective way of doing this is to retransmit a word several times and then compare them, throwing out the words that don't match the majority. This, however, is extremely wasteful of bandwidth and isn't as effective as ECC's. The ECC's typically add only 25 to 45 percent to the bandwidth, while providing better checks than majority voting.

The ECC's are used extensively in deep space probes. Much of the information being sent is imaging, so every bit is important. This is a prime example of where it would be impractical to request that the information be retransmitted because of an error detection. The request time delay is too great because of the distances involved. So instead of retransmission request on error, ECC is used. The ECC requires a bandwidth increase (sending data faster), unless it is acceptable to decrease the overall update rate. This is a result of increased overhead in the form of more bits (the ECC bits) requiring transmission.

In flight testing, ECC is less important. The rapid repeat rate of the data cycle makes it easier to accept an occasional lost frame. However, these techniques will see increased usage in flight test as onboard processing in data acquisition systems becomes more common. Therefore, it is good to be familiar with the basic mechanism.

An example of a popular ECC technique is the Hamming code. Data are encoded so that a decode matrix, called a parity-check matrix, is used to extract it. If m bits are actual information, then n is the total number of bits that must be sent. Thus, m and n are related by the formula

$$m = n - k$$

where k is the number of rows in the parity-check matrix, and

$$n = 2^k - 1$$

The best way to describe this code is by example. If $k = 2$, then the parity-check matrix H is a k row, n column ($k \times n$, or 2×3 in this case) matrix with $m = 1$, $n = 3$. So $3 - 1 = 2$ extra bits sent for each actual information bit. This is termed a single-error-correcting rate of $R = m/n = 1/3$, or 1 out of every 3 bits sent is information.

Also, if $k = 3$, then H is a 3×7 matrix and $m = 4$, $n = 7$. So $7 - 4 = 3$ extra bits sent for every 4 information bits and $R = 4/7$, or 4 out of every 7 bits sent is information.

If $k = 4$, then H is a 4×15 matrix and $m = 11$, $n = 15$. So $15 - 11 = 4$ extra bits sent and $R = 11/15$, or 11 out of every 15 bits sent is information, and so on. As k increases, the ratio of information bits to total bits sent improves. But the parity-check matrix (decode matrix) increases rapidly.

In an extension to the Hamming code, if an overall parity check is added to the H matrix (another row and column), not only are all single errors corrected, but all double errors are detected as well.

In data transmission, errors are more likely to occur in clusters, or bursts, because of lightning static, or an aircraft rolling its antenna away from the receiving station. The Hamming and extended Hamming codes just described would not be very effective in this situation unless each encoded word was *very* long. One way of making a word look very long is to interleave the words. That is, collect a sequence of words and rearrange them to send all the first bits consecutively, then all the second bits, and so forth. This has the effect of spreading words over a long time. On reception, reorder the bits back to "normal" and then decode them. Any burst of errors is thus scattered through different code words and stands a better chance of correction because each word will have fewer errors and may be within the error-correction limit. To the author's knowledge, this technique is not currently used in the flight test community.

See reference 17 for a more detailed discussion of Hamming codes.

6.4.2.3 Cyclic redundancy code

Cyclic redundancy code (CRC) is a common technique for detecting errors in data. It finds its best application in detecting burst mode errors like interference in a radio transmission. The CRC is a “group code” technique. An entire group (or frame, packet, or block) of information has a CRC code attached that indicates the validity of that group. This information can be used to either accept or ignore the group, or request that the group be retransmitted. Disk drives and group protocols like synchronous data link control (SDLC) commonly use CRC's.

6.4.3 Data packet format

Data are usually organized into groups. Even systems that allow data to be sent with attached labels (theoretically allowing data to be sent in any order or time) tend to have preestablished orders for sending data. It takes more intelligence for the transmitting system to dynamically select what to transmit than it does to instruct it to send a prearranged group of data.

Grouping of data has some advantages. It allows group coding such as CRC to be used, and it simplifies the decoding of information by preknowledge of the content and order of a particular group. It also can save bandwidth, as individual labels are not required. Arranging data in a group means that a group retransmission request (based on a bad CRC check, for example) can identify a group to be retransmitted.

The disadvantage of data grouping is the lack of flexibility in determining what makes the most sense to send based on what information has changed. It is like waiting for a stop light when there is no car in the green light lane. Data that needs to transmit may have to wait for data that doesn't need to transmit.

6.5 Standard Avionics Data Buses

Understanding the concept of a data bus is extremely important. Most modern aircraft are designed to include at least one data bus. This section introduces the concept of a data bus, describes the most commonly used aircraft data buses, provides details about their design purpose and operation, and gives examples of actual aircraft data bus installations.

The term “bus” refers to a common data path for information coming from different sources going to different destinations. This data path may be a group of electrical lines that pass signals back and forth in parallel with each other (parallel buses are common in computer backplanes), or the carrier may be one electrical or optical line that passes information in serial (bit by bit). Data may be time multiplexed (share the same line or lines during different time periods), or it may be modulated on different frequencies and sent concurrently. Time-multiplexing information is called baseband, and modulating concurrently is called broadband. Baseband techniques usually require less encoding-decoding circuitry than broadband techniques and are therefore more prevalent aboard aircraft. Broadband is not covered in this volume.

The prime driver for busing equipment is cost savings. Designing pieces of equipment to fulfill a specific requirement without regard to other possible needs leads to multiple design efforts that cover the same territory and may be incompatible. If standards are established for interfacing equipment, then effort spent on designing an interface can be considerably reduced, thus saving cost. Therefore, define the standard in broad enough terms to cover the foreseen tasks. At the same time, be specific enough to prevent ambiguity and incompatibility in different implementations designed to the same standard.

6.5.1 MIL-STD-1553/1773

Avionics integration, or sharing information between different airborne electronic subsystems, has fast become a necessity to meet aircraft mission requirements. This equipment includes navigation systems, computers,

pod-mounted sensors, weapons guidance, radar, flight control systems, displays, and avionics test equipment. To economically meet the requirements, the SAE (Society of Automotive Engineers) formed a committee (A2K) in 1968 to establish basic requirements for a serial data bus. The goal was to (1) reduce systems cost, (2) increase reliability, and (3) increase the availability of systems. Various data bus schemes were designed in the late 1960's and early 1970's. In 1973, lessons learned by the A2K committee from these bus implementations and further study resulted in MIL-STD-1553. This standard, and wider recognition of the need, led to more study, and in 1975 the MIL-STD-1553A revision was released. The current revision was released in 1978 as MIL-STD-1553B (ref. 18).

MIL-STD-1553 establishes information transfer formats, protocol, and electrical characteristics for avionics data transfer. It is part standard and part specification. The standard portion deals with the information transfer while the specification portion concerns electrical characteristics of the bus. Line impedance and voltage, signal coding technique, modulation, channeling method, and isolation are included in the specification (ref. 19).

6.5.1.1 Terminal types

There are three types of equipment attached to a 1553 data bus: a system controller (or bus controller (BC)), a remote terminal (RT), and a bus monitor (BM).

A BC controls the use of the bus (don't speak until spoken to). It initiates information transfers on the data bus. There is only one system controller active on the bus.

An RT is a bus device that responds to specific bus addresses and commands from the system controller. This is the most prevalent terminal type, as many typically exist on a 1553 data bus.

A BM listens on the bus and extracts information but does not inject any information onto the bus. It is used for instrumentation, or as stated in the standard, for information to be used at a later time. Instrumentation for flight test purposes does not want to disturb the bus or change its normal operating conditions. It also wants to obtain information about messages sent to RT's on the bus, each of which is responsible for responding to the BC. Two devices cannot respond at the same time, so one of the receiving devices (the monitor) remains passive.

Figure 6-1 is a diagram of an F-16 aircraft bus network. Note that each subsystem is attached to two bus lines. This is a dual redundant configuration. The data are passed on one line unless problems are encountered, then communication is attempted on the other (backup) line. Exactly what action is taken when error conditions are met is system dependant and not usually covered in MIL-STD-1553.

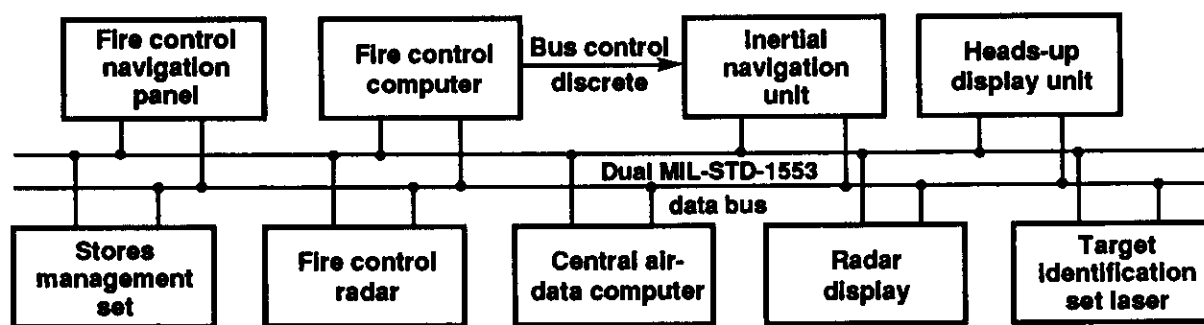

910789

Figure 6-1. The F-16 avionics system architecture.

With this basic understanding of the connectivity of the bus, MIL-STD-1553 is examined from the bottom up, starting with the hardware connections and encoding technique.

6.5.1.2 Data bus cable

The following is a summary of MIL-STD-1553B cable specifications:

- Twisted pair shielded
- A 30-pF capacitance/ft maximum
- A 4-twists/ft minimum
- A 75-percent minimum coverage for shield
- Characteristic impedance (Z_0): 70 to 85 ohms at 1 MHz
- Attenuation less than 1.5 dB/100 ft at 1 MHz
- Each end terminated with a resistor equal to $Z_0 \pm 2$ percent
- Stub requirements:
 - Transformer coupled (long stub)
 - Direct coupled (short stub)

The MIL-STD-1553 bus is thus defined as a twisted pair, shielded electrical cable coupled to terminal devices (sources and destinations of signals) by stubs. Figure 6-2 shows the two types of legal connections to the data bus: direct coupled and transformer coupled. Note that in both cases the terminal is isolated from the bus by at least one transformer. The term "direct coupled" refers to the coupling of the stub to the bus. If the distance to the terminal transceiver is less than 1 ft, then direct coupling is acceptable. The author found that some 1553 bus systems have operated with direct-coupled stubs considerably longer than 1 ft. But when troubleshooting a bus system, the first suspect areas are those that do not adhere to the specification. Therefore, to avoid problems, adhere to the specification from the beginning.

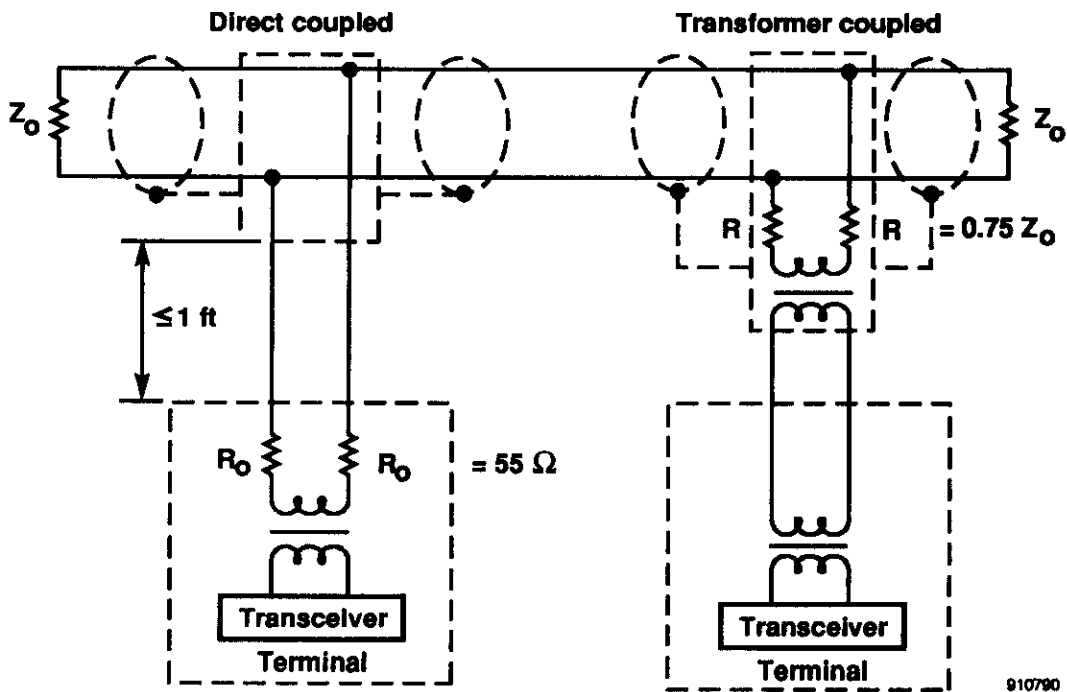

Figure 6-2. Connections to the MIL-STD-1553 data bus.

6.5.1.3 Terminal characteristics

Tables 6-1 and 6-2 summarize data bus terminal output and data bus terminal input characteristics.

Table 6-1. MIL-STD-1553 terminal output characteristics.

Description	Transformer coupled	Direct coupled
Load	70 ohms, ± 2 percent	35 ohms, 2 percent
Levels	18 to 27 V peak to peak	6 to 9 V peak to peak
Maximum zero crossover distortion	± 25 ns peak to peak	± 25 ns peak to peak
A 10 to 90 percent rise-fall time	100 to 300 ns	100 to 300 ns
Overshoot-ringing	± 900 mVp	± 300 mVp
Noise	14 mV rms	5 mV rms
Symmetry	± 250 mVp	± 90 mVp

Table 6-2. MIL-STD-1553 terminal input characteristics.

Description	Transformer coupled	Direct coupled
	Square to sine wave, 1 MHz	
Signal		
Zero crossover distortion (ZCD)	± 150 ns	± 150 ns peak to peak
Response amplitude	0.86 to 14.0 V peak to peak	1.2 to 20.0 V peak to peak
No response amplitude	0 to 0.2 V peak to peak	0 to 0.28 V peak to peak
Common mode rejection DC to 2 MHz	± 10 Vp	± 10 Vp
Impedance 75 KHz to 1 MHz	1000 ohm	2000 ohm
Noise rejection	1×10^{-7}	1×10^{-7}

6.5.1.4 Data bus operation

Data bus operation is **baseband**. Only one message exists on the bus at a time.

Data bus operation is **asynchronous**. Words have no regular, predictable relationship to each other and messages are not required to occur at specific, regular, predictable intervals. Most bus traffic will be regular, however, because of a specific implementation's regular cycling of data—but this is not required in the standard. The bus will be quiescent (inactive) unless the BC has initiated activity.

All bus transactions are **command-response**. The BC sends a command, and the RT addressed will respond with (at least) a status word.

Messages are sent **half duplex**. Terminals will either be receiving information—status or sending information—status, but not both simultaneously.

6.5.1.5 Word types

Figure 6-3 charts the three types of 1553 word formats. The **command word** always comes from the BC and initiates the bus activity. The RT addressed by the command word always responds with a **status word**. The status word is the first word returned from the RT addressed by the command word. Status words only come from RT's. **Data words** can come from either BC's or RT's. They are the "meat" of the message. Each data word includes 16 bits of data. As the meaning of this data is not proscribed by MIL-STD-1553, it is up to the software in the receiving terminal to interpret it.

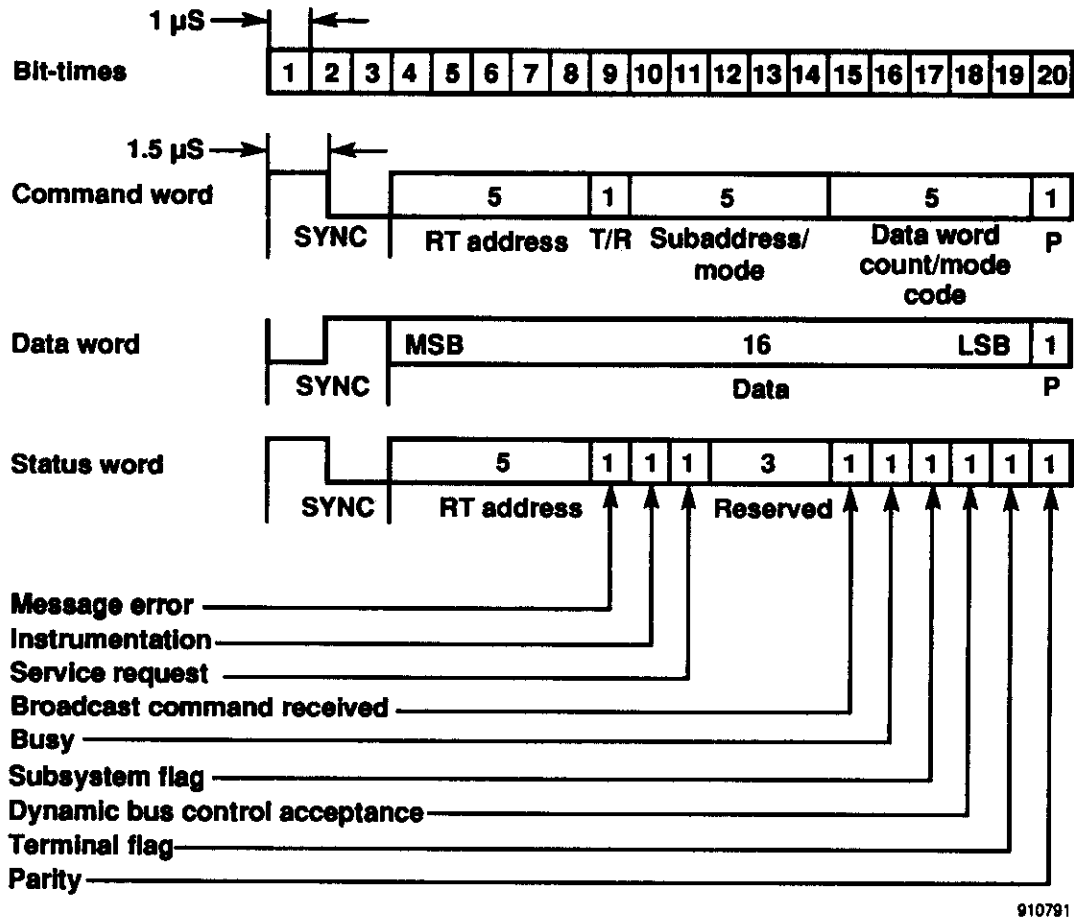

Figure 6-3. Word formats for MIL-STD-1553.

6.5.1.6 Word formats

All words passed over the twisted pair 1553 bus cable are sent encoded as **Manchester II biphas-level (BIΦ-L)** (fig. 6-4(a)). A logic "0" is a negative-to-positive transition in the middle of a bit time (shown in the figure as the trailing edge of the 1 MHz bit clock). A logic "1" is a positive-to-negative transition in the middle of a bit time. This type of code is self-clocking, meaning that a separate clock line is not required for the receiving terminal to decode the word. At least one transition is guaranteed during each bit time—and frequently two transitions. Figure 6-4(b) is an example of a biphas-encoded data stream. Biphas coding is compatible with transformer coupling and tape recording (no DC component).

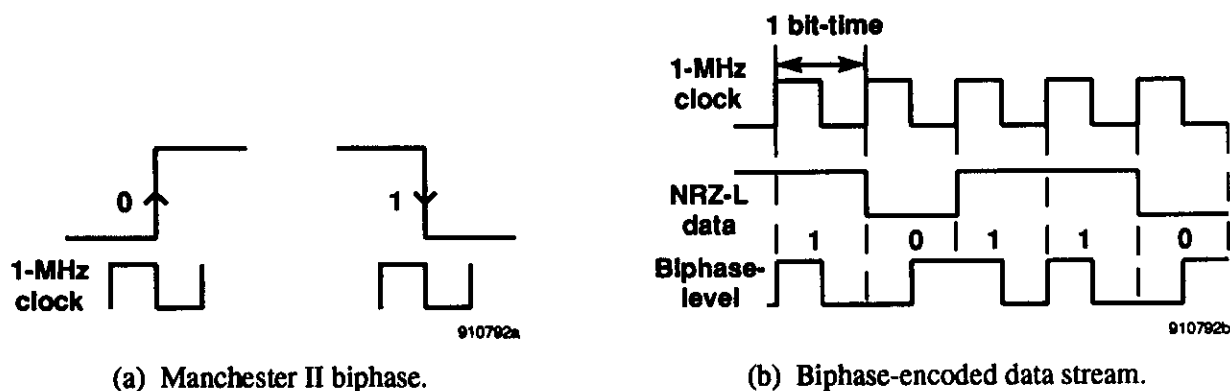

Figure 6-4. Data encoding for the Manchester II biphas-level.

A MIL-STD-1553 word is 20 bit-times long, where 1 bit-time is 1 μ sec (reciprocal of 1 MHz bit rate) (fig. 6-3). Of these 20 bit-times, 16 are message contents (sent most significant bit first). The remaining 4 bit-times are used for word overhead, namely sync bits and parity. Sync bits are required because the standard is asynchronous. The parity bit is odd parity, meaning that there must be an odd number of logic 1's in the last 17 bit-times of the word (does not include sync bit-times). If bits 4 to 19 have an even number of 1's, then the parity bit is set to 1 to make an odd number of 1's. Otherwise, it is set to 0.

In figure 6-3, the command word has a 5-bit field for an RT address. This allows 32 addresses. One of these addresses, 31, is reserved as the broadcast address, an address that *all* RT's should recognize (but not return a status for). The transmit-receive (T/R) bit is set to 1 if the RT is to transmit and to 0 if the RT is to receive. The subaddress/mode field is 5 bits long. Addresses 0 and 31 indicate that a mode code will follow in the next 5 bits. That leaves 30 addresses (1 to 30) for subaddresses. If the subaddress/mode field is 1 to 30, then the next 5-bit field of the command word indicates the number of data words expected to be in the message. If the subaddress/mode field is 0 or 31, then these 5 bits are a mode code. A mode command is a diagnostic or hardware override command. It allows actions like changing the bus controller, initiating self-tests, and override transmitter shutdown. A complete list is found in MIL-STD-1553.

The status word bits 4 to 8 hold the address of the RT transmitting the status word. Bits 9 to 19 indicate various error conditions and are set to 0 unless an error condition is seen. Action taken by the BC on receipt of error bits set is system dependent.

The sync bits take up 3 bit-times, but there is only one transition during that time. From the previous discussion of Manchester II biphas encoding, this single transition is illegal. Remember that biphas requires at least one transition *each bit-time*. This makes it easy to determine what part of a message is a sync pattern. Note in figure 6-3 that though there are three types of words, there are only two types of sync bits. Command and status words have a high to low transition in the middle of the sync time, and data words have a low to high transition.

The only way to tell whether a word is a command word or a status word is if the instrumentation bit is used. The instrumentation bit is always 1 in the status word and that bit position (bit 10) is always 0 in the command word. Note that mandating bit 10 to be 0 in the command word reduces the subaddresses from 32 to 16 (5 bits to 4 bits). For this reason, most installations do not use the instrumentation bit. This is unfortunate, because recovery from anomolous bus conditions, as well as bus monitoring, is made more difficult.

6.5.1.7 Bus message formats

Figure 6-5 shows the different types of bus message formats. A thorough study of this chart will clarify MIL-STD-1553 bus message transactions. Note, as stated earlier, that the bus activity always starts with a command from the BC, and that the first word from the addressed RT will always be a status word. If data is

sent from the BC, the data words follow the command word. The RT will receive the words before responding with a status word. If the BC is requesting data to be transmitted from the RT to the BC, then the data from the RT follows its status word.

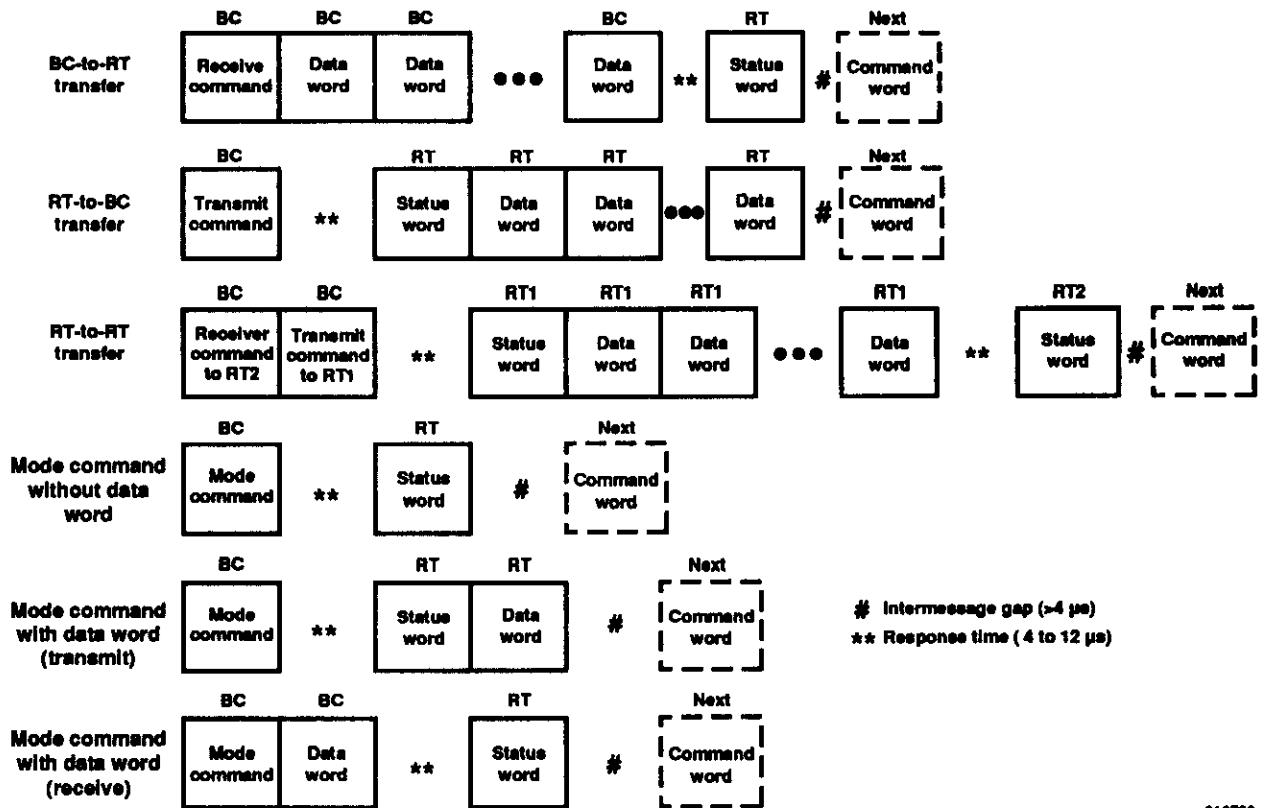

910793

Figure 6-5. Bus message formats.

If the BC initiates a transfer from one RT to another RT, then the message is more complicated. The BC sends two command words: the first to set one RT to receive data, and the second to set another RT to send data. Then, the sending RT sends its status-data stream on the bus, where the receiving RT accepts it. When the transfer is complete, the receiving RT sends its status word on the bus.

MODE Commands set RT hardware and may or may not involve a data word.

Broadcast modes are not illustrated as they are very seldom, if ever, used. U.S. Air Force Notice 1 prohibits the use of broadcast modes on all U.S. Air Force aircraft. The broadcast mode allows a BC to send a message that will be received by all RT's and expects *no* status word. (Since all RT's receive the message, which would respond? Only one can.) It is inadvisable for a command-response system to allow a command only bus transaction.

An RT must keep track of messages. It can't just trigger on a command word. The RT has no way of differentiating between a command word and a status word, unless the instrumentation bit is used, which is seldom. This is an important consideration in bus monitors. If bus monitors are trying to pull data off the bus and not just record every bit transition, then they must pay particular attention not only to what are expected to be command words, but also to the *contents* of status word error codes. Then bus monitors know whether an expected data transfer is going to complete.

6.5.1.8 MIL-STD-1553 notices

The 1553 standard has been revised in the form of "Notices." Notices can be thought of as implementation practices desired or mandated by certain organizations. Notice 1 puts several limitations on the MIL-STD-1553B standard. Whereas the standard permits switching of a bus controller (by use of a mode command), Notice 1 does not. The standard defines a broadcast mode; Notice 1 says not to use it. The standard allows a single bus, or multiple redundant buses; the Notice specifies that all implementations shall be dual redundant. The Notice also points out the differences between MIL-STD-1553A and MIL-STD-1553B and tightens cable characteristics (impedance and shielding).

There is a Notice 2 that further defines some timing variables implied within the standard. Options are described in the area of status word bits, mode codes, data bus redundancy, and coupling techniques. Notice 2 is generally observed outside the U.S. and is reflected in STANAG 3838, which is a NATO document that includes 1553 within it.

6.5.1.9 Design tips for MIL-STD-1553.

When any standard has different versions, some level of incompatibility is introduced. This is the case with the two prevalent 1553 standards: MIL-STD-1553A and MIL-STD-1553B. Another version that differs from both the A and B revisions is found on some aircraft, notably the McDonnell Douglas F-18 aircraft. In flight test instrumentation work, where retrofitting and multiple aircraft types are instrumented, an understanding of the potential problems (pitfalls) in mixing different revision compliant equipment is important. The most common difference is in expected response time after a message is passed.

It is extremely important for a flight test instrumentation engineer to understand the limitations of the MIL-STD-1553 data bus. There are classes of signals that are considered inappropriate for 1553 communications. These are:

1. High signal bandwidth data (single signals above 400 Hz) like FM and video.
2. Signals used to control startup of the system prior to initialization of the 1553 system.
3. Backup signals that are required for safety of flight if complete 1553 system failure occurs.

The most important of these classes from a flight test instrumentation (FTI) engineer's standpoint is high signal bandwidth data. In flight research work, highly regular, high-data-rate requirements do not work well when passed through a 1553 bus.

Many flight test activities involve development of avionics systems. In these tests, it is important to analyze all of the bus activity, including the timing and message gaps. This generally cannot be done in real time, so a requirement for recording the bus traffic is generated. Unfortunately, the protocol used effectively to pass messages on the bus presents difficulties in data analysis. Remember that the analyst may be interested in more than the contents of the data packets. A way must be found to encode the bus timing information as well as the data. A further complication is that the 1-Mbit/sec 1553 data rate is too fast for most conventional recording mechanisms. Also, as many as six separate 1553 data buses must be recorded. A variety of recording techniques have been developed. The most common technique is called track splitting. A single stream coming in from a 1553 bus is split across several tracks, allowing the bit rate of each tape channel to be reduced. However, this technique requires several decommutators to reconstruct the original data flow from one data bus, and if one tape track has problems, it affects the whole message. Use of new wideband tape recorders allow a single 1553 bus data flow to be recorded on one tape track. To facilitate data extraction from the tape, it is a common practice to synchronize the data before it is recorded. This is accomplished by creating a data stream that has no "inactive" time and includes synchronization words. In some systems, timing checks are done on the bus and illegal separations or other bus errors cause error words to be set and recorded on tape along with the data.

During bus inactive times, dummy words are recorded. The advantage is that standard IRIG decommutators can be used to extract the information. Even though IRIG PCM formats are used, computer analysis must be done to determine what data are there (a particular parameter cannot be identified by its position in the frame). The 1553 commands must be examined to see what the contents of the 1553 frame represent.

If the data bus is sufficiently unloaded (few messages sent compared to the total amount of time available), then using first in, first out (FIFO) buffers can allow the use of lower tape recording speeds. During full bandwidth activity, the FIFO is filled. The FIFO empties at a lower speed onto the tape. As long as the FIFO does not overflow, the tape will receive a steady stream of data. If the FIFO empties, then dummy words are put on the tape to fill out the time. In more sophisticated versions, time tagging and parameter identification are also added.

6.5.1.10 MIL-STD-1773 and STANAG

The MIL-STD-1773 can be thought of as an optical version of MIL-STD-1553. Message handling is based on the same standards, but optical instead of electrical transmission is used.

As demand for data transmission in excess of 1 Mbit/sec increases, other data bus techniques are being looked into. The STANAG 3910 describes the characteristics and requirements of a high-speed data bus with options for the transmission medium and controlling mechanism. For example, an implementation of STANAG 3910 might include a high-speed optical bus for high-speed data transmission as well as a conventional 1553 1-Mbit/sec data bus (STANAG 3838) for control of the high-speed bus data transmissions. The high-speed bus, running at 20-Mbit/sec with 4096 16-bit words/data packet is controlled by the 1-Mbit/sec conventional 1553 bus. This hybrid approach lowers the risk of adopting a completely new control protocol over the high-speed bus. Figure 6-6 shows part of the scheme. The high-speed bus can be thought of as an add-on "dumb" bus. The low-speed 3838 bus handles the conventional data transactions and controls data transfers on the high-speed bus. This kind of bus architecture is planned for use in the European fighter aircraft (EFA).

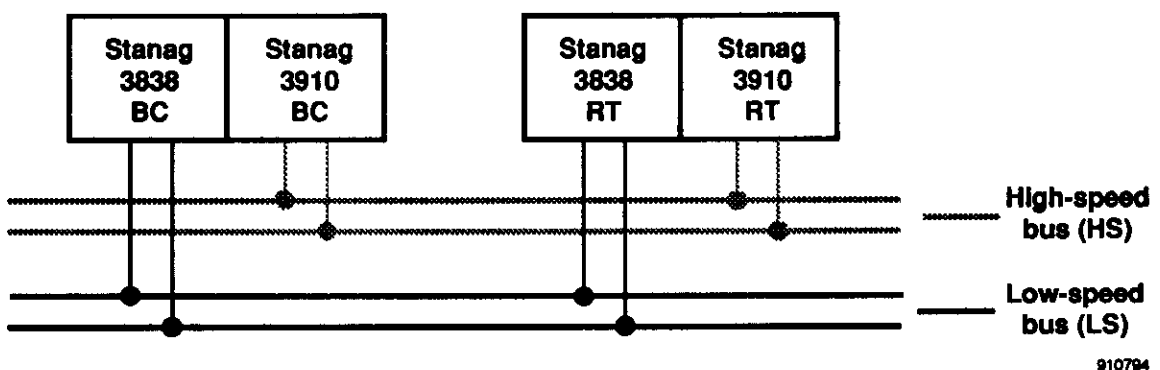

Figure 6-6. Hybrid high-speed/low-speed bus.

6.5.2 ARINC 419/429/629

Aeronautical Radio, Inc. (ARINC), Annapolis, Maryland, publishes the ARINC specifications for use on civil aircraft. There are many ARINC specifications addressing all areas of information transfer between both analog and digital avionic devices.

6.5.2.1 ARINC 419

The ARINC Specification 419, "Digital Data System Compendium," is a catalog of several digital data transmission systems used in the early days of digital avionics. The ARINC 419 is a non-self-clocking signal of

NRZ format. Therefore, it requires a clock line and a synchronization line, as well as the signal lines. The ARINC 419 is obsolete, but some older equipment is still used in flight test work.

6.5.2.2 ARINC 429

The ARINC Specification 429, "Mark 33 Digital Information Transfer System (DITS)," addresses the need for a generally applicable digital information transfer system having capabilities not provided for in ARINC 419. The specification draws from the experience gained from preparing the ARINC 419 specification, but is distinct from it. It was first adopted by the Airlines Electronic Engineering Committee in 1977 and has undergone at least nine revisions (ref. 20).

The ARINC Specification 429 describes a serial, digital data exchange between a transmitter and one or more receivers. The data transfer is unidirectional and open loop, meaning that no intrinsic receiver acknowledge is required by the transmitting device. This unidirectional point-to-point transfer makes ARINC 429 not really a "bus" in the accepted sense of the word (see sec. 6.5), but is nevertheless referred to as the "ARINC 429 data bus."

Data are transmitted from a designated output port over a single twisted and shielded pair of 20- to 26-gauge wires to a receiver or group of receivers (unidirectional). Bidirectional data flow is not permitted on a given pair. The signal is trilevel. A logic "1," or "Hi," is transmitted as +10 V for the first half bit-time and a logic "0," or "Lo," is transmitted as -10 V for the first half bit-time. The second half bit-time in all cases is 0 V, or "null." This coding is called return-to-zero (RZ) bipolar modulation and is very easy to decode from oscilloscope traces. See figure 6-7 for a coding example and figure 6-8 for transmitter-receiver voltage tolerances.

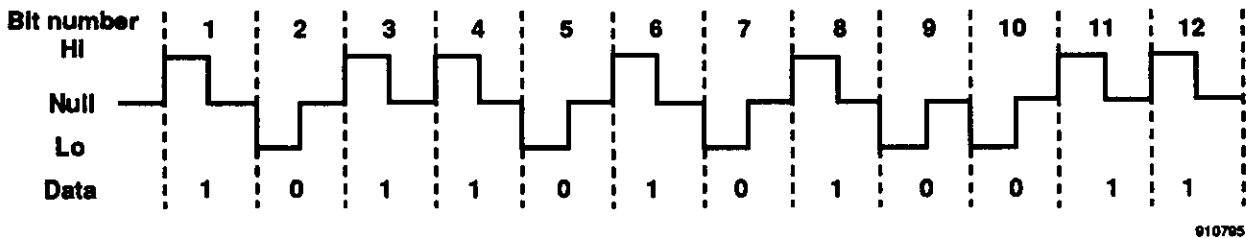

910795

Figure 6-7. Bipolar RZ coding.

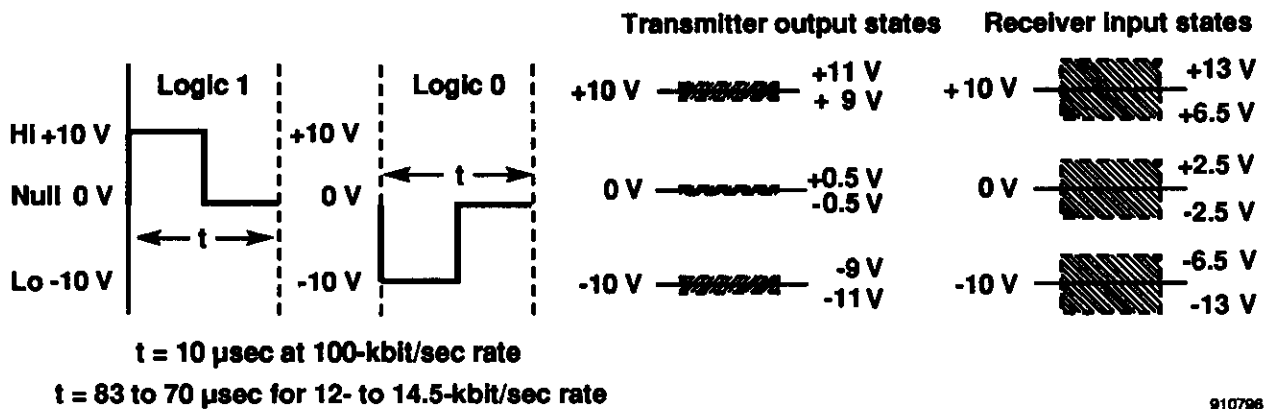

910796

Figure 6-8. The ARINC 429 bit timing and signal levels.

Table 6-3 shows the meaning of the SSM fields. There are conventions for the directional sense of parameters. The ARINC bit 29 is the sign bit of the two's complement number. In that sense, it is conventional in computer nomenclature to call it the MSB of the number, and not bit 28 as the ARINC specification refers to it. Note, from (a) in the table that a "west" direction sense is equivalent to a "minus" number. Thus, the two's complement binary representation of 117° west longitude would be -117. When BCD or discrete data is represented, bits 30 and 31 are used for status, but bit 29 is not used for a sign (table 6-3(b)).

Table 6-3. Sign-status matrix.

(a) BNR SSM										(b) BCD, discrete SSM							
Bit			Status	Directional sense						Bit		Status or directional sense					
31	30	29		31	30												
0	0	0	Failure warning	Plus	North	East	Right	To	0	0	Plus	North	East	Right	To	Above	
0	0	1	Failure warning	Minus	South	West	Left	From									
0	1	0	No computed data	Plus	North	East	Right	To	0	1	No computed data						
0	1	1	No computed data	Minus	South	West	Left	From									
1	0	0	Functional test	Plus	North	East	Right	To	1	0	Functional test						
1	0	1	Functional test	Minus	South	West	Left	From									
1	1	0	Normal operation	Plus	North	East	Right	To									
1	1	1	Normal operation	Minus	South	West	Left	From	1	1	Minus	South	West	Left	From	Above	

The source-destination indicator (SDI) field is used to identify what devices information is coming from or going to. This is generally used to differentiate between like parameters with the same label. If an avionics system has three inertial reference units attached to the same control panel, receipt of the appropriate SDI code by the IRU's from the control panel assures it that the controlling information is for that IRU. So, a navigation computer receiving information from the three IRU's can tell which unit sent which information by examining the SDI field of the parameter. Table 6-4 illustrates the typical definition of the SDI field.

Table 6-4. Source-destination indicator (SDI).

Bit		Installation
10	09	(source or destination number)
0	0	4, all call, or not used
0	1	1
1	0	2
1	1	3

In some cases, the SDI bits are not used, and that field is an extension of the data field where more precision is required. Using this technique, up to 21 bit numbers can be represented in one ARINC 429 word (20 bits plus sign).

Although each ARINC word is defined in the specification, there is nothing to prevent a departure from the specification to define labels and data contents for custom applications. The ARINC 429 physical and data link layers (wiring and message protocol) of the specification could still remain intact. This is sometimes done in flight test. The X-29 aircraft flight control system uses a triple redundant ARINC 429 bus that does not conform to specification definitions of labels and data contents.

Although the ARINC 429 word is 32 bits, it does not conveniently break down into byte size or 16-bit groupings in the order that the ARINC bits are sent. Some ARINC transceiver circuits regroup the bits in a more computer-logical sequence (fig. 6-10 and ref. 21). Note that the data bits are contiguous and most significant justified

in data word two. The lower resolution data bits can be linked together from the most significant bits of data word one onto data word two. The label has been turned around so that its MSB is on the most significant end of the second 8-bit byte of data word one. The miscellaneous *P* and *SSM* bits are put in the remaining bit positions.

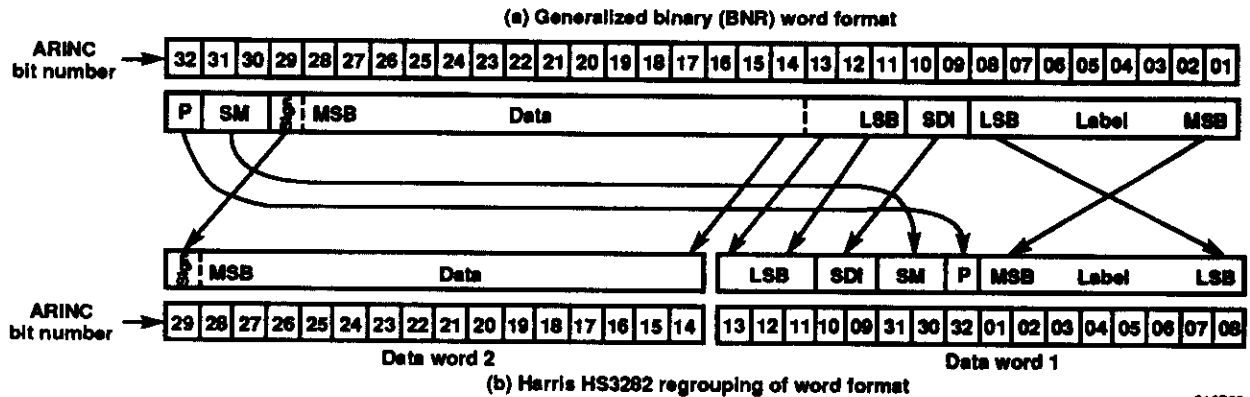
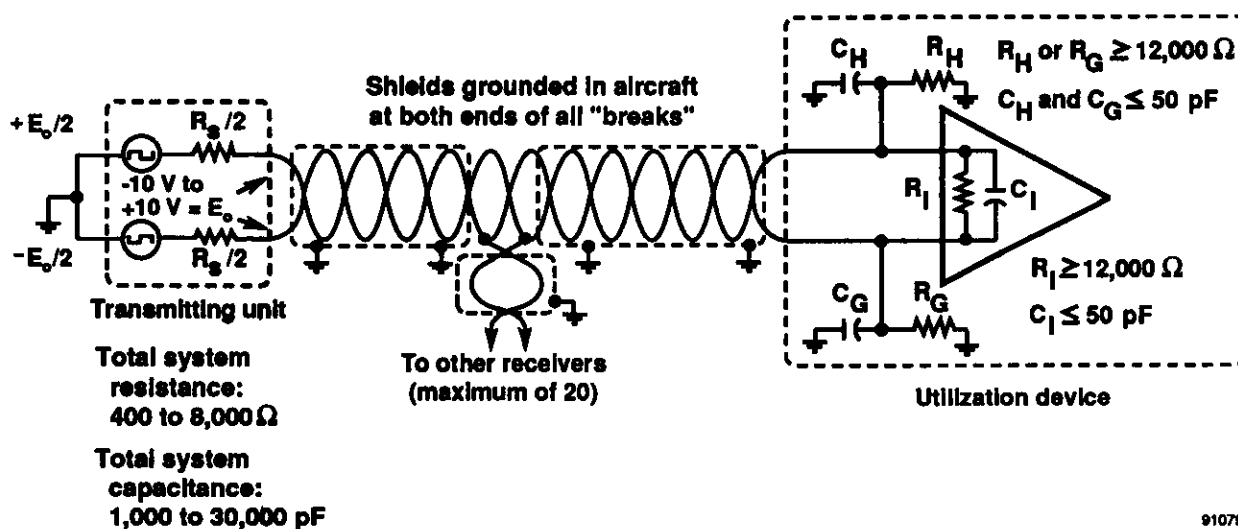

Figure 6-10. Example of ARINC 429 bus interface bit regrouping (Harris HS3282).

Two data rates are specified in ARINC 429: 100 kbit/sec and 12 to 14.5 kbit/sec. These rates are called high-speed and low-speed operation, respectively. It is more accurate to express these rates as 83- to 70- μ sec bit-times and 10- μ sec bit-times, respectively, because the bit stream is not continuous. These rates are one and two orders of magnitude less than MIL-STD-1553 data rates. Civil avionics data do not typically require high-sampling rates. Its flexibility and performance priorities are different than the military requirements leading to the formation of MIL-STD-1553. The highest transmitting rate/label specified by ARINC 429 is 64 times/sec. A few calculations show that it is impossible to send a data stream consisting of all 256 possible labels, each at 64 samples/sec. Usually, only a subset of labels is sent at mixed sampling rates (64, 32, 16/sec).

At 12.5 kbit/sec, many flight test organizations have designed receivers that use generic 8-bit microprocessors to software decode the ARINC 429 signal. Examples are given in reference 8. At 100 kbit/sec, it is preferable, though somewhat expensive, to use available special-purpose ARINC transceiver integrated circuits or hybrids for this "front end" task.

The impedance of an ARINC 429 transmitter is approximately 75 ohms, not considered critical. There is no specific length specification. The receivers exhibit ≥ 12000 ohms resistance. No more than 20 receivers should be connected to one transmitter. Shield grounding should be done at both ends of a cable run. Figure 6-11 is a diagram of input-output circuit standards.



910799

Figure 6-11. The ARINC 429 input-output circuit standards.

6.5.2.3 ARINC 629 (DATAC)

The DATAC bus, developed at Boeing (Seattle, Washington), is a general-purpose data bus clocked at 1 MHz. It utilizes twisted pair, unshielded wire. Subsystems interface to it by transformer coupling. The transformer core is woven into the wire (one primary turn) nonintrusively, so the bus wire need not be broken to attach a new device (fig. 6-12). The bus uses current mode transfer, and can be either synchronous or asynchronous.

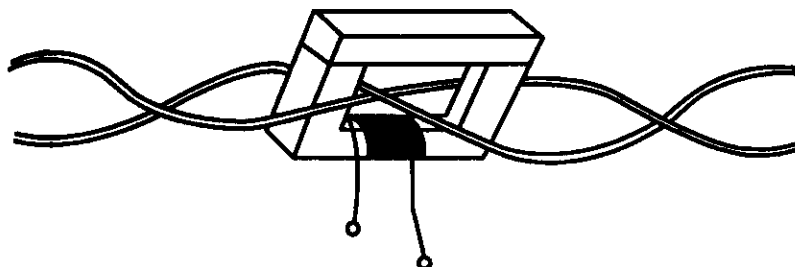

910800

Figure 6-12. The ARINC 629 (DATAC) bus coupling.

The NASA Langley Research Center is using this bus on a Boeing 737 project to pass information on navigation, flight control, display, and data subsystems. The bus is used synchronously (mode C) to make predictable time frames for passing data. All subsystems are "master" in that each send data to the bus *without* arbitration. The clock master sends a signal on the bus to start a frame. The other subsystems are preset to look for a specified "bus quiet" (bus inactivity) before sending their data. Each has a different length of time to wait. Then, each will insert data in the order of increasing bus quiet. The subsystems are not allowed to send data more than once/frame. The amount of data sent by each terminal may vary (it is fixed on the 737 system) provided it will fit in the frame time (with the other terminals' data). Since the frame rate is *constant* (it's controlled by the PCM encoder), the overall data are delivered synchronously (regularly). The PCM system oversamples (at five times the rate of the DATAC frame) to allow it to fit into the DATAC frame. The DAS is a DATAC bus monitor that sees *all* of the data on the bus, but only passes along the data which was specified as desirable. The PCM encoder rate used on this project is 11.5 Kword/sec.

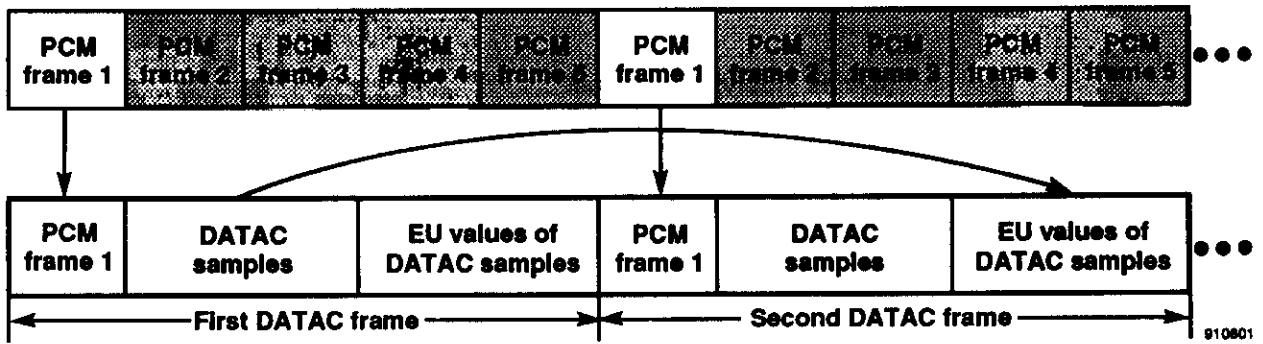

Figure 6-13. The DATAC frame encoding.

With the PCM encoder sampling at five times the DATAC bus frame, PCM frames 2 to 5 are not used. This may seem a waste. But if taken to the limit, with the PCM encoder sampling infinite times each DATAC bus frame, simultaneous sampling is achieved. Or no time skew occurs between the first data sampled and the last. Five times is not infinite, but the time skew is five times better than data sampling spread across an entire DATAC bus frame.

In figure 6-13, the PCM sampling accounts for only 1/5 of the DATAC frame time. The second 2/5's is reserved for DATAC samples, with the remaining 2/5's reserved for DATAC engineering unit values. The engineering unit information is delayed by one DATAC frame to allow the system time to calculate from the DATAC samples.

The DATAC bus provides an easy way to read information from flight control, navigation, pilot display, and data acquisition (PCM encoder) systems, while eliminating synchronization problems encountered with other bus techniques.

The data acquisition subsystem (PCM) terminal provides the master clock. If this clock fails, a bus monitor subsystem provides the clock. If that subsystem fails, the bus reverts to mode A (which means asynchronous), where each subsystem provides its own clock. Even in this mode, no bus crash is possible because of the bus quiet check. The bus would still continue to function, but some element of synchronism would be lost because of drift between clocks.

Boeing Commercial plans to use the DATAC bus for their standard bus architecture.

6.5.3 H009

The H009 is a forerunner of the MIL-STD-1553 data bus used on the F-15 aircraft. Like the 1553 data bus, it has a 1-Mbit/sec data rate. Unlike the 1553 data bus, the H009 has a bit clock line as well as the data line. These two lines are phase related. A logic 1 is interpreted when the bit clock line and the data line are in phase and a 0 occurs when they are out of phase (fig. 6-14). Tight tolerances on skew make this a difficult bus to interface to.

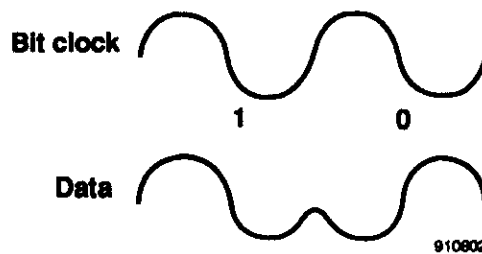

Figure 6-14. The H009 bus waveform.

6.6 General-Purpose Data Buses

6.6.1 RS-232/422/423/449

These “standards” (there is very little standard in the use of these data links) have been around for many years. The RS-232 was developed primarily to define a link between data terminal equipment (DTE) and data communication equipment (DCE). A DTE is a device, like a computer or video display terminal (VDT). A DCE is usually a modem (ref. 22). Figure 6–15 shows a basic data communications hookup, with the standard names for the components.

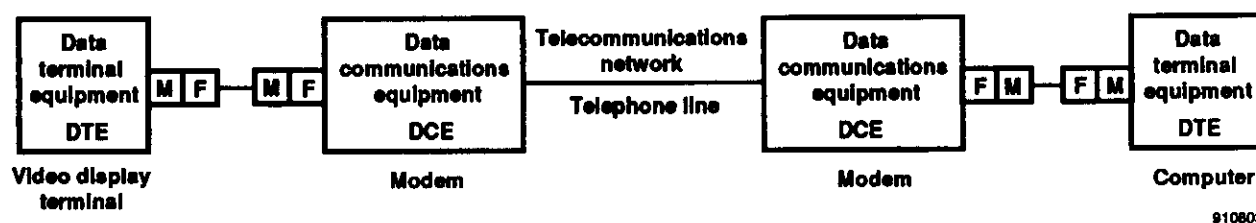

Figure 6–15. Basic data communications system.

Because the data transmission uses a very simple asynchronous serial technique, large-scale integration (LSI) components were developed early. Many liberties have been taken in using it for purposes other than its original intention. Everything from voltage levels and connector genders to code contents have been altered to pass data from one device to another. Also in figure 6–15, note that the lines connecting DTE to DCE devices have boxes labelled “M” and “F.” These boxes show the gender of the connector as specified in the standard. In the standard, DTE devices are to be equipped with male connectors (M) and DCE devices should have female connectors (F). This standard is generally followed for DCE devices like modems, but is often disregarded for DTE devices where both male and female connectors are found. This has caused unending confusion. As all signal lines are point to point, and signals flow only in one direction, the connector pins *transmitting* from the DCE must be *received* by the DTE, and conversely. So the signal *direction* definitions are tied to the connector *gender*. If this standard were followed, it would be obvious how to connect equipment together: female connectors connect to male connectors. The standard is often disregarded or not understood. Therefore, a careful look at the electrical definition of each device’s pin is necessary to ensure compatibility.

Figure 6–16 shows the voltage levels specified in RS-232 transmissions. Note that typical voltages expected are +12 V and –12 V. The ± 25 V in the figure represents the maximum unloaded source voltage range. Often, particularly in battery-operated applications, voltages of ± 9 V are used. Many times the input thresholds do not strictly match the RS-232 standard ranges, and an input expecting 12 V will not recognize a 9-V input. Problems are avoided if commercial integrated circuits designed specifically for RS-232-C interfacing are used.

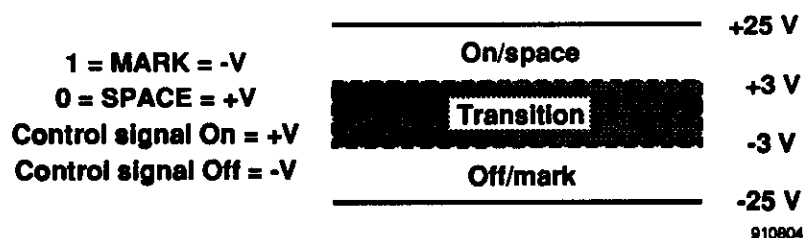
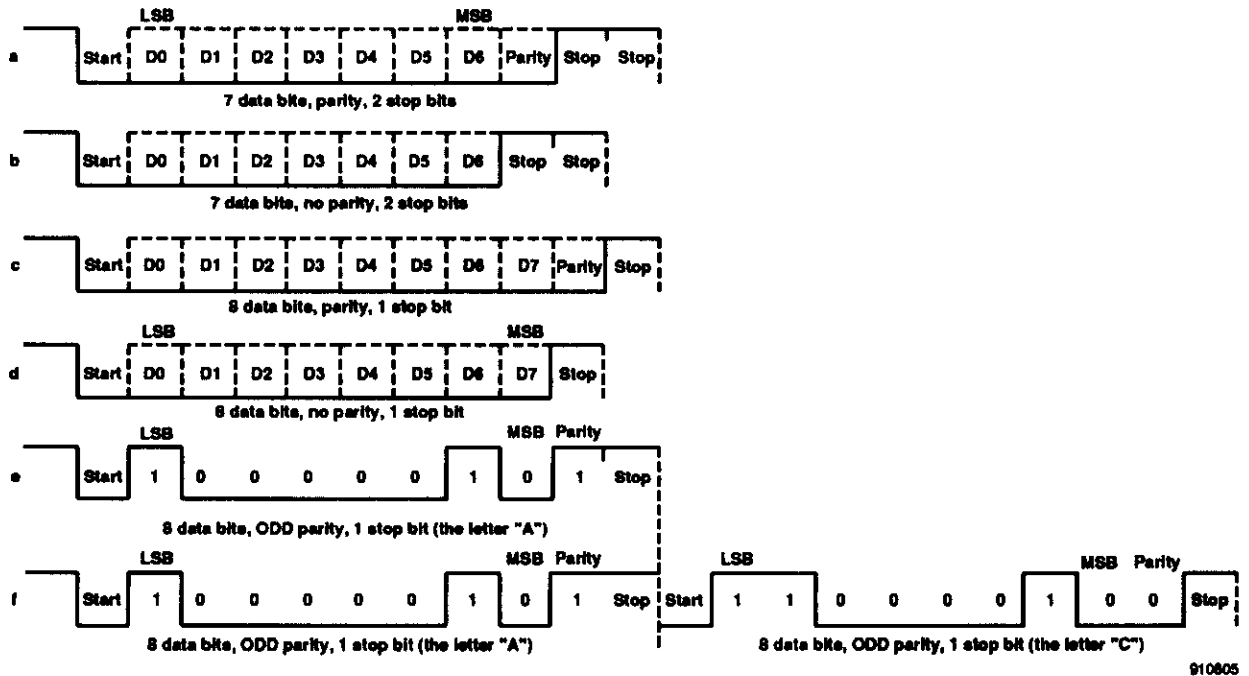

Figure 6–16. The RS-232-C voltage levels.

The RS-232-C standard does not address the type of data encoding that takes place. It specifies pin numbers and genders, signal voltage levels, and communication channel handshaking, but not coding of data. The

ANSI X3.16 (ref. 23) defines a bit-sequential, or serial-by-bit, transport mechanism for exchanging data. This transport mechanism (use of start bits, stop bits, parity) can be used to pass any binary data. The ASCII (American Standard Code for Information Interchange) code is the most common data code found on RS-232-C lines. This 7-bit code, agreed on by both the CCITT and ISO international organizations, can be found in reference 24. The 8-bit versions are becoming more popular, and variations allow for international character sets (fig. 6-17). This code is designed to send alpha-numeric characters that are commonly found in text files.



910605

Figure 6-17. Examples of bit-sequential ASCII.

The figure shows formats for transmitting data by way of bit sequential ASCII code. The formats begin with a "start" bit, which is a 1 bit-time "space." The next 7 or 8 bits contain data, least significant bit (LSB) first, followed by a "parity" bit, if desired. The parity bit is a quality-of-data check based on the number of 1's in the data field. If an odd parity is desired, then the parity bit is set to 1 provided the number of 1's in the data field is even. (This makes the total number of 1's in the data-parity field odd—even number plus one is an odd number.) If even parity is desired, then the parity bit is set to 1 provided the number of 1's in the data field is odd. (This makes the total number of 1's in the data-parity field even—odd number plus one is an even number.) The transmitter and receiver must be matched in the type of parity used to avoid error reports.

In figure 6-17(f), a sequence of two serial ASCII-encoded characters are shown using odd parity. The letter "A" has two 1's in it, so the parity bit is set to make a total of three 1's (three is an odd number). The letter "C" has three 1's in it, so the parity bit is not set. Three is already an odd number and requires no "help" from the parity bit.

The minimum number of stop bits required is usually either one or two. A stop bit is merely dead time, or the time after one character is sent and before the next one starts. This means that the serial ASCII coding is *asynchronous*. Each character stands on its own, with an arbitrary time between them. The need for this is obvious. A typist entering text on a keyboard usually does not type in regular keystrokes. Time between keystrokes is random.

In the author's opinion, the best format is the one shown in figure 6-17(d) (8 data bit, no parity, 1 stop bit). A parity bit is generally not meaningful as most software does nothing with the information. This format allows for receiving data sent by figures 6-17(a), (b), or (d) (both the parity bit from (a) and the first stop bit of (b) masquerade as another data bit in (d)). It also allows for sending 8-bit binary data.

Besides the expected confusion as to whether any two RS-232 devices can communicate with each other, a serious limitation of RS-232 is the line length. Adhering strictly to the standard, line lengths should be no longer than 50 ft. It is possible to extend this length by a considerable distance, though not recommended. As a single-ended (as opposed to differential) bus, long transmission lines—particularly aboard an aircraft—make it vulnerable to common mode problems. The longer the cable length, the lower the acceptable data rate. No specific rates are called for in the RS-232-C standard. Traditionally, RS-232-C data rates are one of the following (rates are in baud): 110, 300, 600, 1200, 2400, 4800, 9600, and 19200. A *baud* is a unit of information transfer rate. This is often confused with *bit* rate. Often, the two are interchangeable. Bit rate refers to the number of binary digits/sec that are being transmitted. Baud rate refers to the communication rate or the number of discrete conditions or signal events/sec. In some cases the bit rate is much higher than the baud rate. Suppose, for instance, that at any given time two bits of information can be observed. One bit is contained in the frequency of the signal and the other bit is contained in the phase. Suppose also that these two bits change at a rate of once/sec. The baud rate, or communication rate (how often the data is changed), is once/sec. The bit rate, or signalling rate, is two bits/sec, because two bits (frequency and phase content) are changing every sec. So in this case, the bit rate is twice the baud rate.

The RS-422 and RS-423 specifications transmit signals similar to what is found on RS-232 lines, but allow faster and longer transmission. The RS-423, like RS-232, is an *unbalanced*, or single-ended, transmission. The ground references on each end of the transmission are tied together. Transmission speeds up to 100 kbaud and line lengths up to 4000 ft are allowed. The RS-422 is a *balanced*, or differential, transmission system. Neither of its transmission wires are tied to the ground reference at either end. This technique makes the transmission system less sensitive to common mode (undesired signals affect both wires equally, cancelling the effect). It allows transmission speeds up to 10 Mbaud at line lengths up to 4000 ft. Figure 6-18 shows the cable lengths as a function of data rates for RS-422 and RS-423, respectively (ref. 25). These plots were empirically derived. The curve is flat at the lower data rates because the signal amplitude requirement is the limiting factor. As the data rate increases, the signal rise and fall times become the more significant factors, limiting the allowable line length.

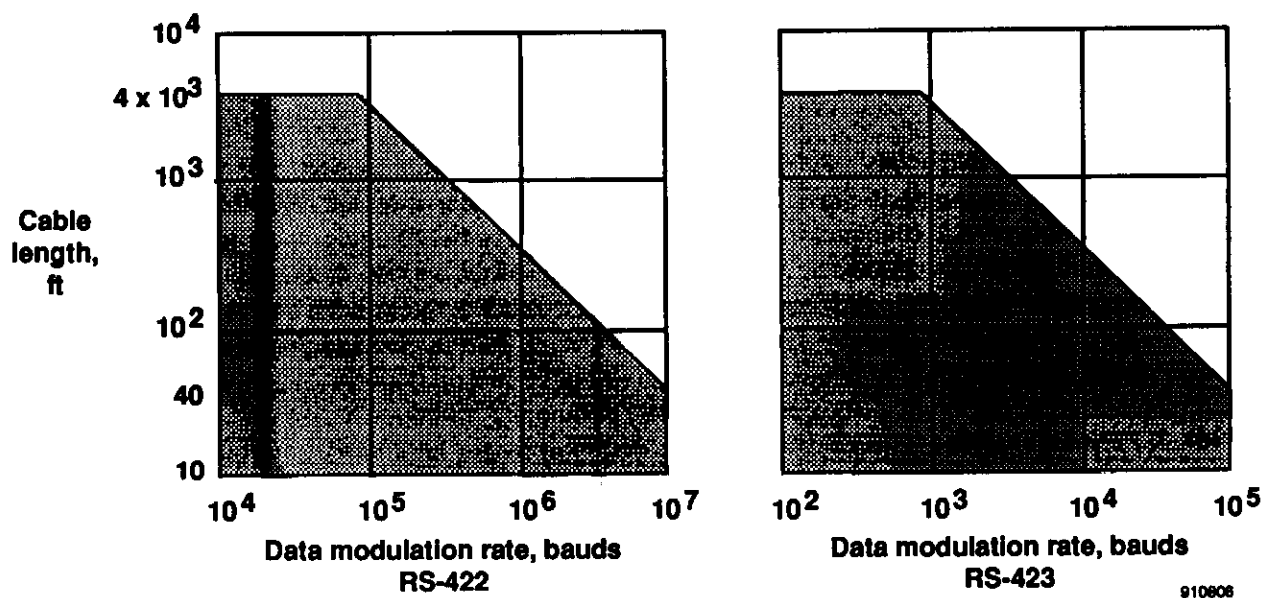

Figure 6-18. Data modulation rate as a function of cable length.

Of the three standards, RS-422 offers the best speed and line length.

The RS-449 standard, together with the RS-422 and RS-423 standards, is intended to replace RS-232-C. While RS-422 and RS-423 define electrical interface standards, RS-449 specifies the functional and mechanical characteristics of the interface between data terminal and data communications equipment. Unlike RS-232-C,

RS-422, and RS-423, the RS-449 standard specifies exact mechanical definitions of connectors, which are 37-pin and 9-pin connectors. The RS-449 also clearly states, using diagrams, many of the more poorly understood standards stated in RS-232-C. The RS-449 is compatible with CCITT recommendations V.24 and V.54.

In the author's opinion, the only good reason to design flight systems with RS-232 interfaces is to allow easy interface to existing ground equipment, such as a computer or VDT. Any flight system being used for data transmission, especially where both ends of the bus can be custom designed, should plan to use a balanced line standard that allows longer line lengths and higher data rates, such as RS-422.

Despite all attempts to enhance or replace the RS-232-C standard, it is still widely used. Its vagueness allows designers to believe they have a free hand in bending the standard to their own purposes.

6.6.2 IEEE 488/HP-IB/IEC 625

For better understanding, it is useful to review the history of this bus' development. In the early 1970's, there was little standardization in connecting measurement test equipment to computer systems. With the advent of microprocessors, it became feasible to build "smart" instruments that handled major parts of their own computing tasks. Hewlett-Packard of Cupertino, California, developed a bus to interface measurement instruments like digital voltmeters and scanners to minicomputers. Hewlett-Packard designed many instruments for this bus named the HP-IB (Hewlett-Packard interface bus) in 1974. Hewlett-Packard participated in various standardization groups, which used this bus as their starting point in defining industry standards.

In 1976, the International Electrotechnical Commission (IEC) adopted IEC 625-1. It differs from HP-IB only in the connector used. In 1978, the Institute of Electrical and Electronic Engineers (IEEE) adopted IEEE 488-1978 (now called 488.1), which is fully compliant with HP-IB. The American National Standards Institute (ANSI) adopted the IEEE Standard and published it as ANSI Standard MC 1.1. The bus concept is also known as the GP-IB (general-purpose interface bus). Under one or more of these names, the HP-IB has become widely used throughout the world as a means of making test measurements easier. It is continually being revised to include enhanced features.

6.6.2.1 Bus operation

The HP-IB operates on two levels: hardware interconnection and message passing. The instrument interconnection is passive. A cable with 16 signal lines (8 for data and 8 for data-message control information) usually connects the instruments and computer in a daisy-chain fashion. An HP-IB device must function as one of the following: talker, listener, or controller. A controller device manages the bus, determining which devices are eligible to send and receive data. A talker can transmit data to other devices on the bus. A listener can receive data from other devices. Most devices can listen to their control information and then talk to send their measurement results. An HP-IB bus must consist of at least one talker and one listener. Figure 6-19 shows a typical HP-IB connection. In the figure, one controller (usually a computer) and three instruments, which may be both listeners (to receive control information) and talkers (to report results back to the controller or other listener) are shown. The detail illustrates how the daisy chain connections are usually mated by stacking connectors.

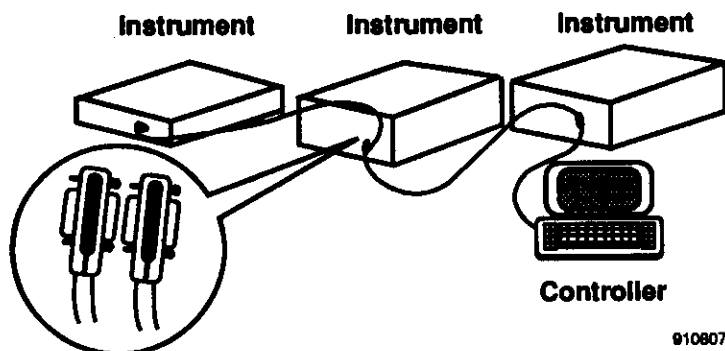

Figure 6-19. The HP-IB (IEEE-488) connections.

The power of the system lies in the potential intelligence of each measurement device on the bus and the ability to schedule testing events and sequences in the controller. “Smart” and “dumb” devices can coexist on the same bus. All of the HP-IB’s evolving enhancements are aimed at standardizing higher levels of message protocol, which previously were device dependant. The HP-IB is a bus that was designed from the “bottom up,” or as manufacturers conceive of enhancements in message handling, they are reviewed and incorporated into the standards.

6.6.2.2 Bus application and limitations

The HP-IB’s use in flight test is limited to aircraft with enough space to accommodate large (usually rack mountable) test instruments like transport-size aircraft. The bus is widely used in ground support equipment and laboratory calibration.

The maximum number of instruments on the same bus is 15. The maximum cable length is limited to 20, or 2 times the number of devices, whichever is less. It is an 8-bit parallel (not serial) data bus. Therefore its cable, which must carry 24 wires, is usually stiff. It passes data in binary-coded decimal (BCD) or ASCII formats. This increases its compatibility with other systems, but decreases its speed. The HP-IB is not intended for passing high-frequency measurements. The previously mentioned bottom-up implementation of the HP-IB often causes problems in programming communications between different measurement devices, particularly if the devices are made by different manufacturers. Often, one manufacturer will rely on an “enhancement” that the other manufacturer is unfamiliar with.

There are mechanisms for extending the bus in length and number of devices, but these are not part of the bus standard. For a detailed description of the HP-IB, see references 26, 27, and 28.

6.6.3 Ethernet (IEEE 802.3)

Ethernet is a popular bus technique in ground-based facilities for networking systems together. It is, to the author’s knowledge, not used on aircraft for flight-test purposes. However, it has some features of interest.

Ethernet is a baseband bus, where signals are time division multiplexed. It provides a 10-Mbit/sec serial path between many systems, and requires no bus master. It has a linear topology, and is usually a coaxial cable system (although other media are often used). A cable is strung around a facility. Those needing access to the bus clamp a transceiver onto the coax. Each device has a unique, factory-defined address. The data link layer of protocol is defined as part of the 802.3 specification, sending data in packets. Higher layers of protocol are up to the systems wanting to communicate and will not affect those systems that are not addressed.

Control of the bus is determined by who gets there first. If another device wants to control the bus, it first checks for energy on the bus, implying that another system already has control. If it finds that the bus is in use, it will back off, wait for a random time, and try again. As devices are not allowed to stay on the bus forever, every device will be guaranteed access.

This bus has become very popular. Many support products, supporting a wide range of physical, data, and network-link protocol products, exist for several popular computer systems from micros to mainframes.

6.7 Sampling Data Buses for PCM Transmission

In recent years, avionic subsystems involved in navigation, pilot displays, and flight control have become major parts of aircraft. As these systems must be developed and tested before becoming operational, the flight-testing community must monitor bus activity between the avionic subsystems. Aircraft data bus activity must be recorded and, at least in part, be frequently telemetered.

Traditional flight-test data acquisition involves sampling of sensors where the PCM system has control over the sampling times and sampling rates. With most data buses, however, these transactions take place completely asynchronous to traditional sampled PCM systems. The engineer must understand what kind of data bus system information is being sought. Is it important to maintain data bus frame integrity? Must timing relationships between buses be maintained? Must *all* bus traffic be recorded or transmitted? Or is it enough to just select certain bus words and maintain a most-recent-values table for transmission at a noncritical rate? Understanding the requirements makes a big difference in the complexity of the bus interface scheme used.

In most cases, flight-test engineers want the data acquisition system to monitor the bus, but *not* interact with it. Interacting with it infers transmitting some type of data acknowledgment on the bus, which requires the system under test to take some action on this data or acknowledgment. To some extent, this changes the action of the system under test. The mark of a good test instrument is one that affects the system under test minimally. For example, a good voltmeter has a very high impedance, which draws the least current from the system it is probing.

The following examines the worst case of monitoring data buses—recording all bus activity, including command words, sync bits, and intermessage gaps, if they exist. Assume that this information must end up in a digital computer system to evaluate the bus traffic. Two big problems must be addressed: (1) The data bus speed is probably too high for current flight recorders to handle; and (2) message gaps, if sufficiently long, introduce a DC component into a signal, and direct (nonmodulated) recording techniques will have trouble.

One common technique for dealing with a high recorder data rate is to split the signal over several tracks, as was discussed in section 6.5.1.9. For example, bus data can go into a FIFO buffer that splits the stream bit by bit across five tracks on the tape. Now each track need only record at 1/5 the data rate of the bus. Each track has a sync word added, and fillers are added during gap times. The tape must be replayed through a “desplitter” to put the data stream back together.

A good example of sorting out 1553 bus data in real time and storing it in a form amenable to later computer analysis was developed for Aeritalia in Turin, Italy. Its main goal was to reduce the bandwidth of data recorded on board so that the number of tracks required on the recorder were also reduced.

This system uses the bus inactive time (usually 40 percent or more) to add timing information and to reduce the output bit rate. *All* the information is kept, but in compressed form. Data about the 1553 sync bits, parity, validity, and so forth are encoded. The time of frame acquisition is also encoded. This allows full analysis of the bus and maintains time and frame integrity, while not requiring as many filler words in each frame or as many tracks on the tape. Filler words are required if bus activity is low enough for a period of no transitions to occur during a PCM frame. The data are stored in a quasi-IRIG format, including sync words and a regular, cyclic frame pattern. However, the data are not fixed word-position dependent within a frame, like standard IRIG format. Each frame must be analyzed in software to extract the appropriate information.

Under normal bus activity, data can be stored on one tape track. If heavy loading occurs, data can be split across two tracks. However, it is split on a message-by-message basis, *not* on a bit-by-bit basis. This is easier to decommutate and is more reliable. (In the bit-by-bit splitting, if one track dies, *all* information is lost as they are so intertwined.) The time tag is optional and is defined as a 16- or 32-bit counter of arbitrary resolution. Knowledge of 1553 specifications can be used to distinguish between response times, intermessage gap times, and so forth to check for message validity in the software decommutation. Bus failures can be detected also.

The goal is to reduce the bandwidth of data on board to reduce the tracks required on the recorder. This led to the pseudo-IRIG technique, because in conventional IRIG PCM, each parameter must have its own slot in a cyclic frame and would be sent even if it has not changed values. Thus, the bandwidth would be driven up. A conventional IRIG PCM system would also lose 1553 frame integrity and information about the frame, sending only data and not "gap" information (ref. 15).

Reference 29 is a good source of information on extracting 1553 bus data from a specially encoded IRIG PCM stream.

6.8 Wave Shaping for Special Situations

6.8.1 Pulse trains for telemetry transmission

Of primary concern in telemetry transmission is bandwidth. That is, how much of the frequency spectrum is used to transmit a signal. Two factors enter into this: (1) how sharp the rise and fall times of a pulse train are, and (2) how many transitions/sec are required. Minimizing bandwidth requires the pulse train waveshape to be as nearly sinusoidal as possible, and requires the bit rate to be minimized.

The simplest coding technique also corresponds to the lowest bandwidth signal: NRZ-L (nonreturn to zero-level). Its power spectral density centers around the bit rate. In this code, a logic 1 is a high and a logic 0 is a low. Unfortunately, no transitions take place when a long string of 0's or 1's occur. Sophisticated bit synchronizers must be used to keep the data stream in lock.

6.8.2 Pulse trains for tape recording

Tape recorders are sensitive to steady-state response. This means that long periods of no transition in a data stream do not record well. Therefore, NRZ-L coding is not usually the coding of choice. A code that requires transitions to occur at least every bit time or two works better. Codes like BI Φ -L (Manchester II biphas-level) and DM-M (delay modulation-mark (Miller)) are commonly used. Pseudorandom techniques that shift the power spectral density curve closer to the bit rate while keeping it off of steady-state condition are better. Figures 94 and 97 of reference 1 show code definitions and power spectral density curves, respectively.

6.8.2.1 Filtering and encoding considerations

For tape recording of digital PCM streams, one of the most important considerations in direct recording is the power spectral density of the signal. The coding technique selected depends on this. For example, an NRZ-L signal does not guarantee that there will be any transitions in a given length of time from 0 to 1 or from 1 to 0. If the data being recorded are all 0's or all 1's, there are no transitions and no self-clocking is possible. All information is DC, which is not suitable for tape recording. The BI Φ -L code has zero-frequency components at DC. However, its bandwidth is approximately twice that of NRZ-L. The DM-M code has a small amount of frequency components at DC with approximately the same bandwidth as NRZ-L, which makes it a good compromise for tape recording. This subject is covered in more detail in reference 1.

6.8.2.2 Enhancement techniques

Sometimes recording high-speed data streams is complicated by not having recording mechanisms that can keep up. In other words, linear recording of data streams cannot always be done. One technique that has been used to work around this bandwidth limitation is called track splitting, which is discussed in detail in section 6.7. In track splitting, serial data stream is sliced up and consecutive chunks are laid in parallel tracks of a recorder. This complicates the encoding onto the recorder as well as decoding it later. It does, however, allow more recording time on a given tape. The technique has been used successfully in recording MIL-STD-1553 avionics data (at one Mbit/sec) onto 14-track tape recording at a much slower rate.

An important enhancement technique that is sometimes overlooked is to *reduce* the amount of data recorded. In many situations, not all of the bus traffic is required for analysis. Careful selection of parameters can significantly reduce recording requirements.

7 DIGITAL DATA STORAGE

7.1 Tape Recorders

Tape recorders have been the mainstay of flight data acquisition systems for many years. Though ground-based computer systems also have used tape recording for many years, their mechanism of storage differs from most flight systems. Ground-based systems typically store information in parallel across several tracks in a "byte serial" fashion. This can be thought of as digital recording. Flight systems, in contrast, usually record in an analog fashion. Even if data is digitized before being sent to the recorder, it is recorded in a "bit serial" fashion, one track/channel or data stream.

Flight recorders have several tracks; 14 or 28 are common. Each track can record one PCM data stream or one FM channel. So for a 14-track tape unit, up to 14 FM channels or 14 PCM data streams can be recorded, or a mixture of the two. One track is usually devoted to recording the IRIG time to synchronize data acquisition with the actual time the data was taken.

This kind of tape recording has limited bandwidth—1 to 2 hr recording at data rates under 300 kbit/sec. Techniques have been developed to use track splitting: spreading a serial data stream across several tracks. This technique is commonly used for storing high-speed data streams in real time. References 1 and 15 provide information about tape recording, signal conditioning, and encoding.

7.2 Semiconductor Memory

Semiconductor memory has been among the most exciting technologies to watch over the past several years. Memory densities have increased dramatically, while costs and power consumption have plummeted. Fifteen years ago, minicomputer systems containing more than 32 kbytes of memory were uncommon. Today, many laptop computers contain 1 or 2 Mbytes.

7.2.1 Random access memory

Memory capacity, speed, weight, size, and power consumption are key issues in selecting memory for data storage. Cost is usually less of an issue. Random access memory (RAM) is a type of read-write memory; that is, each memory location can be accessed in any random order and each location can be either read from or written to. For data storage requiring high speed, it is hard to exceed the performance of RAM. Much of the information stored passes through RAM anyway in the process of passing it on to the storage device. Densities reach a level where size and weight are acceptable for low to medium amounts of data storage in flight test. For example, if a flight test project has 20 parameters, each requiring 200 samples/sec for a testing period of 30 min, then this would require 7.2×10^6 bytes of storage:

$$\begin{aligned} &200 \text{ samples/sec for each of 20 parameters (one parameter/byte)} \\ &(200 \text{ frames/sec})(20 \text{ parameters/frame}) = 4000 \text{ parameters/sec} \\ &(4000 \text{ parameters/sec})(30 \text{ min})(60 \text{ sec/min}) = 7.2 \times 10^6 \text{ parameters} \end{aligned}$$

This is a modest requirement for flight testing, but a fairly sizable one for the amount of RAM required. Data storage using RAM tends to be for infrequent, or noncontinuous, storage of data (like test points that span a few seconds).

The RAM is volatile. It requires the application of power at all times to retain its contents. Sophistication in integrated circuit design has allowed modern IC's to automatically revert to a standby mode when its data is not externally required. Standby mode requires considerably less power, usually a few μ amps/IC. Small batteries can keep their contents intact for several months or years.

7.2.2 Electrically erasable programmable read only memory

The EEPROM (or E²PROM) is a nonvolatile memory device (requiring no battery backup power) that can be programmed or reprogrammed (erased) electrically while still in its application circuit (ref. 8). It is well suited for systems requiring small amounts of data storage updated infrequently with noncritical write times (in the msec range). Calibration tables are a good example. The tables may be updated without removing the EEPROM and are not expected to change during a flight. The table values can be expected to be retained even after circuit power has been removed.

7.3 Bubble Memory

Bubble memory uses a method of storing information in tiny magnetic domains, called bubbles. Access to the bubbles is sequential—in rotating order. The bubbles store information in a nonvolatile manner, and information is not lost when power is removed. This storage is completely solid state, and therefore holds much promise in environments like flight test, where lack of vibration-sensitive mechanical parts is desirable.

Bubble memories became available commercially in the early 1980's, but were never widely used. In its early days, these memories were the subject of much advertising "hype" (promises that were never lived up to). Its low-memory densities, low-speed, heavy-weight, complex support circuitry, lack of substantial improvements, and high cost have conspired to keep bubble memories out of most applications.

Bubble memories have been used in flight testing applications, but only those where infrequent access of "read-mostly" memory was required, and access times were not time critical. One such application was instrumented by the NASA Ames Research Center's Dryden Flight Research Facility to support a laminar (smooth air) flow research program onboard a Lockheed C-140 Jetstar aircraft. That system used bubble memory cards in two of the onboard systems. The bubble memory was designed commercially to emulate standard Q-bus floppy disks. They were accessed only to assist the system when powered up and to load the application program into semiconductor (volatile) memory for execution. In this application, real-time response was unnecessary; vibration resistance and small physical size (relative to the floppy disk drive it replaced) were positive attributes.

7.4 Disks

7.4.1 Magnetic (hard and flexible)

Magnetic disks are a very popular way of saving flight data. They are widely used in ground-based systems and are increasingly used on aircraft.

These disks are excellent media to store and retrieve random access data. Access times range in the tens to hundreds of msec, and data capacities are between a few hundred kilobytes and a few hundred megabytes. Flexible (floppy) disks are at the low end of the range in terms of speed and capacity, and hard disks are at the high end.

An advantage of flexible disks is low media cost and high portability. They are also "contact head" devices and are thus less sensitive to vibration problems than are hard disks. Their data transfer rates are in the range of 250 to 500 kbit/sec.

The advantages of hard disks are speed and high-storage capacity. Data transfer rates are from 5 to 10 Mbit/sec. Many hard disks are also sealed (Winchester type) and are less susceptible to a dusty environment than are flexible disks. However, hard disks use expensive media and are "floating head" devices; that is, their recording heads must not contact the surface of the disk. This event is called a head crash and results in the loss of data (and usually a service call to repair the head). Vibration could result in head crashes, and considerable attention must be paid to mounting the drives to prevent this kind of damage, particularly in flight testing.

7.4.2 Optical

Optical disk data storage is emerging as a very exciting technology for data storage. There are few standards currently, as it is still in its infancy. The most important advantage of optical media is its extremely large storage capacity. Storage capacities in the Gbyte range are not uncommon. The most mature technology is the so-called write once, read many (WORM) optical disks. As the name implies, data can be written to the media only once, but read back many times. This is ideal for archiving data like flight data. It is better protected from accidental erasure than is magnetic media. It also tends to be optimal for sequentially stored data because it is recorded in a continuous spiral, like the groove on a record player. Currently, WORM recording speeds are not tremendously fast, averaging a few Mbit/sec.

7.4.3 Interfacing

There are several standards available to interface to rotating disk drives. Interfaces are usually addressed at two levels: drive to controller and controller to processor. The ST506 specification and ESDI define the signals passing between the drive and its controller. The MSCP defines the protocol required for the controlling processor to communicate with the controller attached to the drive(s). The SCSI is a combination of both (protocol and bus). Thus, a drive interface may use both ST506 and MSCP, or just SCSI. Sometimes converters are used to allow a processor sending commands on a SCSI bus to communicate with a drive using ST506. The SCSI is used for more than just disk drives. It is also a general-purpose data transfer bus. With a properly designed system, the processor does not need to know physical details about the device it is communicating with. Whether the device is a disk drive, magnetic tape drive, or a printer, there is little impact on the commands sent from the processor.

8 TESTING

8.1 Failure Modes and Mechanisms of Digital Systems

Modern electronic systems are, for the most part, very reliable systems. Comprised largely of solid-state devices, they are fairly impervious to shock. Their low power consumption minimizes heat damage, and shelf life is virtually unlimited. However, statistically, the more components added to a system, the more likely something will fail. The trend toward highly complex aircraft systems therefore works against the addition of more reliable components.

Digital systems, by nature, tend to be much more impervious to temperature variations than their analog counterparts (see sec. 1.2). Even the analog circuits, while sensitive to temperature variations, are usually not subject to catastrophic failure—except for components that, by the nature of their operation, are expected to dissipate much heat.

However, digital logic is more sensitive to power fluctuations than is analog circuitry. For example, if a current surge (resulting from the sudden switching of a logic level) causes a spike on the power supply line, the logic thresholds of a logic chip may be affected. This, in turn, may cause a logic chip to misinterpret a logic level. As logic circuits make substantial use of memory elements (future action depends on the past), the misinterpreting of a logic level can cause the logic to take a wrong “fork in the road” and get very confused. In contrast, most analog circuits have no memory element, so a temporary perturbation in power has no lasting impact on the system’s performance.

After eliminating (relatively speaking) catastrophic failure and power fluctuations, the failure modes in digital systems are primarily those of synchronization. Assuming that a system has been functional and suddenly develops problems, a good area to look at is the timing relationships between various parts of the system. This is where most time is spent troubleshooting digital systems.

8.2 Hardware Test Methods

In the process of designing and testing digital electronics, like any other electronic system, it is necessary to find and fix problems as well as to evaluate performance. In traditional analog electronic testing, the most important general-purpose test gear is the oscilloscope. In testing digital electronics, the logic analyzer is a very important piece of test gear. This device is a specialized data acquisition tool that allows the operator to see the timing relationships between several digital signal lines. *Timing* is everything in digital systems. The logic analyzer lets the evaluator see the timing relationships between the various digital signals in the system. Glitch detectors can spot signals that appear and disappear between samples—which may point to “illegal” activity on a channel.

Digital oscilloscopes are gaining in popularity. They combine the principles of both logic analyzers (by sampling data digitally) and the analog oscilloscope (by displaying voltage level). Sometimes logic analyzers include one or two channels of digital oscilloscope channels that allow the synchronized observation of the digital timing with observed analog traces.

Pattern generators and microprocessor emulators control the logic (provide a forcing function). Microprocessor emulators are used in development when not all of the hardware is built, or when the system *is* built and interaction with the “guts” of the system is required for testing. A typical emulator will plug into the system in place of a microprocessor and will allow the user to map recognized memory into either the system under test or the emulator itself. In designing embedded microprocessor systems, an emulator is almost indispensable.

An understanding of the timing relationships in a working system is important to check for anomalous operation. Good baseline measurements should be made when the system is declared operational. This is similar to taking your temperature when you are well so that you know what is normal.

If it is possible to use sockets for components, the job of troubleshooting a system at the component level is greatly simplified. Simply replace suspected components until the system works, or replace all parts and reinsert suspect components until it fails. However, use of sockets greatly increases the possibility of a bad connection, which obviously induces failure modes.

Much of aircraft avionic testing that concerns a flight test or instrumentation engineer involves making black boxes communicate properly. This frequently requires specialized testing equipment that is able to analyze data bus traffic and interpret its messages. These units are often expensive, but can save an enormous amount of time in focusing on a problem.

8.3 Software Test Methods

Software is found in many electronic devices today. Hard-wired logic circuits are giving way to firmware (programmed hardware)-controlled logic. More high-level control of sequences (especially those requiring decisions based on parameters that change) use more conventional software. As technology makes it possible to include more processing capability and memory capacity into less space and power, imbedded software is found in more subsystems.

Testing software systems can be challenging. Communication between several processors controlled by several (unsynchronized) oscillators guarantees that the system cannot be tested under all possible conditions. The author has seen digital systems work successfully for several years before a particular set of conditions occurred (as a result of synchronization problems) that caused erroneous operation.

The best a designer can do is to pay attention to timing delays, signal degradation over transmission lines, and design error detection and correction, as well as synchronizing (acknowledge) mechanisms, where possible.

The more a system is modularized, that is, its components act independently without depending on much interplay between subsystems, the easier it is to test. Program logic can then be tested on a subsystem-by-subsystem basis using well-understood tools like program debuggers and emulators (secs. 2.5.2 and 8.2). It is like the difference between being accountable for your own actions as opposed to being responsible for the detailed actions of other people. There is only so much control you can exercise over someone else. As aircraft systems become more complex, modularity becomes the key to successfully testing and integrating systems.

9 RELIABILITY AND SAFETY

9.1 Verification and Validation

Verification and validation is the process where systems are shown to be operating properly. **Verification** is the act of confirming that the system (software, hardware, and so forth) meets the specification. **Validation** determines that the specification itself is correct. Just as it is up to an architect to confirm that the blueprints for a building project are correct (validated), it is up to the building contractor to confirm that the blueprints are followed (verified).

How much verification and validation is required before flight testing is largely a function of flight safety. It is important in man-rated aircraft, where a "bug" in logic can lead to loss of life (or in any aircraft where a crash may result), to do as much ground testing as possible. It may be easier to find problems in actual flight conditions rather than trying to simulate them, but safety prevents that approach.

In general, instrumentation systems used in flight research or flight test are not as critical as systems used directly to control the aircraft flight. As a result, requirements for verification and validation of systems can be relaxed where problems in systems merely result in termination of the test flight. However, assurance is needed that the quality of the data extracted from the aircraft is understood.

9.2 Flight-Critical System Data Extraction

As stated earlier, if data critical to the control of an aircraft is used, mechanisms must be included to assure that failure of part of the system does not result in loss of the aircraft. This is done by installing redundant systems. For example, in figure 9-1, a flight control surface is instrumented by three sensors, each of which is fed into each of three processors. If a single sensor failed, a processor can, by means of majority rule, determine this. It can then throw out the bad sensor data. If one of the processors failed, the other two processors can, again by majority rule, determine this.

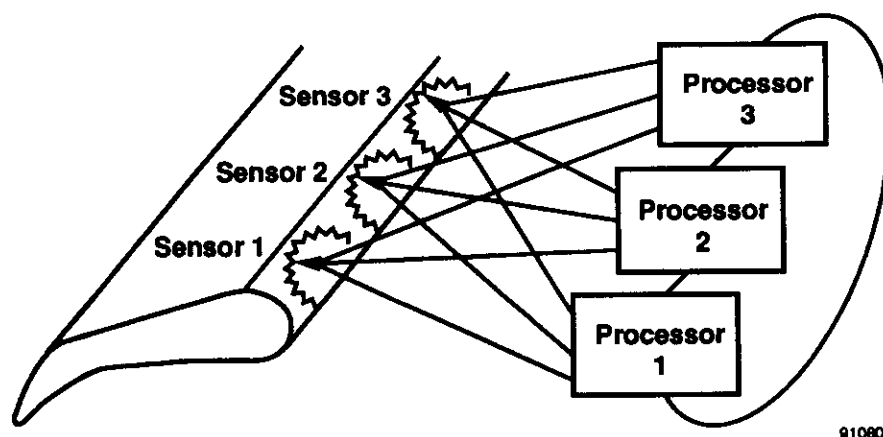

Figure 9-1. Triple redundant sensors and processors.

Extra hardware and system complexity (and usually extra space and weight) are required. As a result, this technique is seldom used with sensor data that are not flight critical.

For data extraction (recording or transmitting), care must be taken that the interface to the data acquisition system does not induce problems in the system from which it is acquiring data.

REFERENCES

1. Veatch, Donald W., and Rodney K. Bogue, *Analog Signal Conditioning for Flight-Test Instrumentation*, AGARDograph no. 160, vol. 17, 1986. Also published as NASA RP-1159, 1986.
2. Spitzer, Cary R., *Digital Avionics Systems*, Prentice-Hall, Englewood Cliffs, NJ, 1987.
3. *The TTL Data Book for Design Engineers*, Texas Instruments, Inc., Dallas, TX, 1973.
4. *CMOS Logic Databook*, National Semiconductor, Santa Clara, CA, 1988.
5. *ALS/AS Logic Data Book*, Texas Instruments, Inc., Dallas, TX, 1988.
6. *FAST Data Manual*, Signetics, Sunnyvale, CA, 1986.
7. *FACTTM Advanced CMOS Logic Databook*, reprint of *Fairchild 1987 FACT Databook*, National Semiconductor, Santa Clara, CA, 1987.
8. Prickett, M.J., *Microprocessor Applications in Airborne Flight Test Instrumentation*, AGARDograph no. 160, vol. 18, 1987.
9. Meiksin, Z.H., and Philip C. Thackray, *Electronic Design with Off-the-Shelf Integrated Circuits*, 2d ed., Prentice-Hall, Englewood Cliffs, NJ, 1984.
10. *DSPatch*, nos. 14, 15, & 16, Analog Devices, Inc., Norwood, MA, Summer 1990.
11. Wilner, Douglass O., and Glenn A. Bever, *An Automated Stall-Speed Warning System*, NASA TM-84917, 1984.
12. *Data Conversion Products Databook*, Analog Devices, Inc., Norwood, MA, 1988.
13. Rabiner-Bernard Gold, Lawrence R., *Theory and Application of Digital Signal Processing*, Prentice-Hall, Englewood Cliffs, NJ, 1975.
14. Oppenheim, Alan V., and Ronald W. Schaffer, *Digital Signal Processing*, Prentice-Hall, Englewood Cliffs, NJ, 1975.
15. Goodenough, Frank, "Switched-Capacitor Filters," *Electronic Design*, vol. 37, no. 8, Apr. 13, 1989, pp. 77-92.
16. Cattunar, S., "Acquisition and Recording an AMX A/C Aeritalia Experience and Present Trends," presented at the European Telemetry Conference, Aix-en-Provence, France, June 1987.
17. Dornhoff, Larry, *Notes on Applied Modern Algebra*, Stipes Publishing Co., Champaign, IL, 1975.
18. MIL-STD-1553B, *Aircraft Internal Time Division Command/Response Multiplex Data Bus*, Military Standard, U.S. Department of Defense, Sep. 21, 1978.
19. MIL-STD-1553, *Multiplex Applications Handbook*, Military Standard, U.S. Air Force Systems Command, 1982. Available from SCI Systems, Inc., Huntsville, AL.
20. *Mark 33 Digital Information Transfer System (DITS)*, ARINC Specification 429-9, Aeronautical Radio, Inc., Annapolis, MD, 1985.
21. *Harris Corp. Data Sheet for HS-3282*, Harris Corp., Palm Bay, FL, 1985.
22. "Interface Between Data Terminal Equipment and Data Communication Equipment Employing Serial Binary Data Interchange," EIA RS-232-C, Electronic Industries Assoc., Wash., DC, Aug. 1969.
23. "Character Structure and Character Parity Sense for Serial-by-Bit Data Communication in the American National Standard Code for Information Exchange," ANSI X3.16-1976, American National Standards Institute, New York, 1976.
24. *Recommendation V.3, International Alphabet No. 5*, CCITT, vol. VIII.1, Geneva, Switzerland, 1977.

25. McNamara, John E., *Technical Aspects of Data Communication*, Digital Equipment Corp., Bedford, MA, 1978.
26. *Digital Interface for Programmable Instrumentation*, ANSI/IEEE 488.1-1987, Institute of Electrical and Electronics Engineers, New York, June 1987.
27. *ANSI/Codes, Formats, Protocols, and Common Commands*, ANSI/IEEE 488.2-1987, Institute of Electrical and Electronics Engineers, New York, Apr. 1987.
28. *IEC 625-1, An Interface System for Programmable Measuring Instruments (Byte Serial, Bit Parallel). Part 1: Functional Specifications, Electrical Specifications, Mechanical Specifications, System Applications and Requirements for the Designer and User*, International Electrotechnical Commission, Geneva, Switzerland, 1979.
29. Vitalone, G., "Decommutation Techniques and Their Integration Into Post Flight Analysis System," presented at the European Telemetry Conference, Aix-en-Provence, France, June 1987.

Index

- A**
A-D 0-1, 3-1, 3-2, 3-3, 3-4, 3-8, 3-10, 3-11, 3-12
ADA 2-7, 2-8
Aeritalia 6-26
aliasing 1-3, 3-5, 3-8, 5-4
amplifier 3-1
analog 0-1, 1-1, 1-2, 1-3, 2-1, 3-1, 3-2, 3-3, 3-4, 3-5, 3-7, 3-8, 5-1, 5-2, 5-3, 5-4, 6-14, 7-1, 8-1
to digital, 0-1, 3-1, 3-2, 3-3, 3-4, 3-5, 3-7, 3-8, 3-10, 3-11, 3-12
ARINC 0-1, 6-3, 6-14
419, 6-14, 6-15
429, 6-3, 6-15
575, 6-16
629, 6-19
704, 6-16
ASCII 0-1, 6-22, 6-25
asynchronous 2-7, 6-2, 6-9, 6-11, 6-16, 6-19, 6-20, 6-21, 6-22, 6-26
avionics 0-1, 1-1, 2-1, 2-7, 6-6, 6-13, 6-14, 6-17, 6-18
- B**
bandwidth 1-3, 3-8, 5-4, 6-2, 6-3, 6-4, 6-5, 6-6, 6-13, 6-14, 6-26, 6-27, 6-28, 7-1
Boeing 6-19, 6-20
737, 6-19
bubble memory 7-2
- C**
“C” language 2-7
calibration 3-6, 3-11, 4-2, 6-25, 7-2
code
Gray, 4-3
nonprogressive, 4-1, 4-3
progressive, 4-2
communication 6-1, 6-23, 8-2
parallel, 6-3, 6-6, 6-25, 6-28, 7-1
serial, 1-2, 2-1, 2-7, 6-3, 6-4, 6-6, 6-7, 6-15, 6-16, 6-21, 6-22, 6-25, 6-28
computer 0-1, 2-2, 2-8, 3-5, 3-7, 4-2, 4-3, 6-2, 6-3, 6-4, 6-6, 6-14, 6-21, 6-24, 6-26, 7-1
cost 2-2, 2-6, 2-8, 3-2, 6-6, 6-7, 7-1, 7-2
- D**
D-A 0-2, 3-3, 3-5, 3-6
data
acquisition, 0-1, 1-2, 2-1, 2-6, 2-7, 3-8, 5-1, 5-4, 6-5, 6-20, 6-26, 7-1, 9-1
compression, 5-4
rate, 1-3, 6-1, 6-2, 6-3, 6-13, 6-16, 6-18, 6-23, 6-26, 7-1
storage, 7-1, 7-2, 7-3
stream, 1-2, 2-6, 6-2, 6-3, 6-10, 6-12, 6-13, 6-18, 6-26, 6-27, 6-28, 7-1
data bus
1553, 6-3, 6-6, 6-14, 6-16, 6-18, 6-20, 6-26, 6-27, 6-28
1773, 6-6, 6-14
ARINC, 6-14
ethernet, 6-25
H009, 6-20
HP-IB, 6-24
RS-232, 6-21, 6-23, 6-24
DATAC 6-19
development
hardware, 8-1
software, 2-8
digital
filter, 3-4, 5-1, 5-2, 5-4
sensors, 2-1, 4-1, 4-2
to analog, 0-2, 3-3, 3-4, 3-5, 3-6
to synchro, 3-6, 3-7
transducer, 4-1, 4-2
disk
coded, 4-1
floppy, 7-2
hard, 7-2
optical, 7-3
displays 2-1, 3-7, 6-7, 6-19, 6-20, 6-21, 6-26
- E**
ECC 0-2, 6-5
EEPROM 0-2, 7-2
EMI 0-2, 6-2
emulator 8-1
EPLD 0-2, 2-5
error
detection, 6-4, 8-2
sources, 3-4, 3-7, 3-10, 5-4, 6-6
ESD 0-2, 2-6
ethernet 6-25
- F**
failure 2-6, 6-13, 6-27, 8-1, 9-1
fiber optics 6-1, 6-3, 6-14
FIFO 0-2, 6-14, 6-26

1553 6-3, 6-6, 6-14, 6-16, 6-18, 6-20, 6-26,
6-27, 6-28

filter

antialias, 1-3, 3-8, 5-4
digital, 3-4, 5-1, 5-2, 5-4
FIR, 5-1
IIR, 5-1
presample, 3-8, 3-10, 5-1
statistical, 5-4
switched capacitor, 5-2
transmission, 6-27

FIR 0-2, 5-1

flight control 0-1, 1-1, 2-1, 3-5, 6-2, 6-7, 6-17,
6-19, 6-20, 9-1

FM 0-2, 1-3, 5-4, 6-13, 7-1

FORTRAN 2-7

G

gain 3-6, 3-7, 5-1
glitch 4-1, 4-3, 8-1
Gray code 4-3

H

helicopter 6-3
HP-IB 0-3, 6-24
hybrid circuits 2-6, 6-18

I

IIR 0-3, 5-1
IRIG 0-3, 6-2, 6-4, 6-14, 6-26, 7-1
isochronous 6-3

L

language 2-7, 2-8
logic
 analyzer, 8-1
 logic families, 2-2, 2-3, 2-5, 2-6

M

Manchester code 0-2, 6-10, 6-27
memory 7-1, 7-2

N

NASA 0-1, 0-3, 6-2, 6-19, 7-2
navigation 2-1, 6-6, 6-16, 6-17, 6-19, 6-20,
6-26
Nyquist rate 3-4, 3-9, 3-10, 5-3, 5-4

O

optical 1-1, 6-1
 disk, 7-3
 encoder, 4-1
 fiber, 6-1, 6-3, 6-6, 6-14

P

PASCAL 2-7
PCM 0-3, 6-2, 6-4, 6-14, 6-19, 6-26, 6-27
performance 1-1, 2-6, 5-1, 6-18, 7-1, 8-1

R

RAM 0-3, 7-1
redundancy 3-9, 6-2, 6-7, 6-13, 6-17, 9-1
reliability 2-2, 3-6, 6-7, 6-27, 8-1, 9-1
resolution 1-3, 3-1, 3-2, 3-3, 3-4, 3-5, 3-8,
3-11, 3-12, 5-3, 6-16, 6-27
RF 0-3, 6-2, 6-3
RS-232 6-21, 6-23, 6-24
RS-422 6-23, 6-24
RS-423 6-23
RS-449 6-23

S

sampling rates 1-3, 3-1, 3-4, 3-5, 3-8, 3-9, 6-2,
6-18, 6-26, 7-1
signal conditioning 1-1, 2-1, 7-1
simulation 2-8
sync bits 6-11, 6-26
synchro to digital 3-7
synchronize 2-7, 4-3, 6-3, 6-13, 6-27, 7-1, 8-1,
8-2
synchronous 4-1, 6-2, 6-3, 6-6, 6-19

T

tape 1-2, 5-4, 6-10, 6-13, 6-14, 6-26, 6-27,
6-28, 7-1
telemetry 1-1, 2-1, 6-1, 6-2, 6-3, 6-4, 6-27
temperature 1-1, 2-6, 3-2, 3-10, 5-1, 8-1
test equipment 6-24, 6-26, 8-1, 8-2
track splitting 6-13, 6-26, 6-27, 6-28, 7-1

V

vibration 5-1, 5-4, 7-2
video 6-13, 6-21

W

weight 6-1, 6-2, 6-3, 6-4, 7-1, 7-2, 9-1
wire 2-7, 6-1, 6-3, 6-4, 6-15, 6-19, 6-23, 6-25

Annex 1

AGARD Flight Test Instrumentation and Flight Test Techniques Series

1. Volumes in the AGARD Flight Test Instrumentation Series, AGARDograph 160

<i>Volume Number</i>	<i>Title</i>	<i>Publication Date</i>
1.	Basic Principles of Flight Test Instrumentation Engineering by A.Pool and D.Bosman (under revision)	1974
2.	In-Flight Temperature Measurements by F.Trenkle and M.Reinhardt	1973
3.	The Measurement of Fuel Flow by J.T.France	1972
4.	The Measurement of Engine Rotation Speed by M.Vedrunes	1973
5.	Magnetic Recording of Flight Test Data by G.E.Bennett	1974
6.	Open and Closed Loop Accelerometers by I.Mclaren	1974
7.	Strain Gauge Measurements on Aircraft by E.Kottkamp, H.Wilhelm and D.Kohl	1976
8.	Linear and Angular Position Measurement of Aircraft Components by J.C. van der Linden and H.A.Mensink	1977
9.	Aeroelastic Flight Test Techniques and Instrumentation by J.W.G. van Nunen and G.Piazzoli	1979
10.	Helicopter Flight Test Instrumentation by K.R.Ferrell	1980
11.	Pressure and Flow Measurement by W.Wuest	1980
12.	Aircraft Flight Test Data Processing — A Review of the State of the Art by L.J.Smith and N.O.Matthews	1980
13.	Practical Aspects of Instrumentation System Installation by R.W.Borek	1981
14.	The Analysis of Random Data by D.A.Williams	1981
15.	Gyroscopic Instruments and their Application to Flight Testing by B.Stieler and H.Winter	1982
16.	Trajectory Measurements for Take-off and Landing Test and Other Short-Range Applications by P.de Benque d'Agut, H.Riebeck and A.Pool	1985
17.	Analogue Signal Conditioning for Flight Test Instrumentation by D.W.Veatch and R.K.Bogue	1986
18.	Microprocessor Applications in Airborne Flight Test Instrumentation by M.J.Prickett	1987
19.	Digital Signal Conditioning for Flight Test by G.A.Bever	1991

2. Volumes in the AGARD Flight Test Techniques Series

<i>Number</i>	<i>Title</i>	<i>Publication Date</i>
AG237	Guide to In-Flight Thrust Measurement of Turbojets and Fan Engines by the MIDAP Study Group (UK)	1979

The remaining volumes are published as a sequence of Volume Numbers of AGARDograph 300.

<i>Volume Number</i>	<i>Title</i>	<i>Publication Date</i>
1.	Calibration of Air-Data Systems and Flow Direction Sensors by J.A.Lawford and K.R.Nippres	1983
2.	Identification of Dynamic Systems by R.E.Maine and K.W.Iliff	1985
3.	Identification of Dynamic Systems — Applications to Aircraft Part 1: The Output Error Approach by R.E.Maine and K.W.Iliff	1986
4.	Determination of Antenna Patterns and Radar Reflection Characteristics of Aircraft by H.Bothe and D.McDonald	1986
5.	Store Separation Flight Testing by R.J.Arnold and C.S.Epstein	1986
6.	Developmental Airdrop Testing Techniques and Devices by H.J.Hunter	1987
7.	Air-to-Air Radar Flight Testing by R.E.Scott	1988
8.	Flight Testing under Extreme Environmental Conditions by C.L.Henrickson	1988
9.	Aircraft Exterior Noise Measurement and Analysis Techniques by H.Heller	1991

At the time of publication of the present volume the following volumes were in preparation:

Identification of Dynamic Systems. Applications to Aircraft.
Part 2: Nonlinear Model Analysis and Manoeuvre Design
by J.A.Mulder and J.H.Breeman

Flight Testing of Terrain Following Systems
by C.Dallimore and M.K.Foster

Store Ballistic Analysis and Testing
by R.Arnold and H.Redd

Reliability and Maintainability
by J.Howell

Testing of Flight Critical Control Systems on Helicopters
by J.D.L.Gregory

Flight Testing of Air-to-Air Refuelling of Fixed Wing Aircraft
by J.Bradley and K.Em

Introduction to Flight Test Engineering
Edited by F.Stoliker and H.Torode

Operational Flight Testing
by M.Williams et al.

Space System Testing
by A.Wisdom

Annex 2

Available Flight Test Handbooks

This annex is presented to make readers aware of handbooks that are available on a variety of flight test subjects not necessarily related to the contents of this volume. It is not necessarily a full listing of such documents.

Requests for A & AEE documents should be addressed to the Defence Research Information Centre, Glasgow (see back cover). Requests for US documents should be addressed to the Defence Technical Information Center, Cameron Station, Alexandria, VA 22314 (or in one case, the Library of Congress).

<i>Number</i>	<i>Author</i>	<i>Title</i>	<i>Date</i>
AFFTC-TIH-88-004	Hendrickson, C.L.	Flight Testing Under Extreme Climatic Conditions	1988
AFFTC-TIM-75-11	Pihlgren, W.D.	Aircraft Vertical Center of Gravity Determination Using the Ground Inclination Method	1975
AFFTC-TIH-84-1	Lush, K.J.	Electrical Subsystems Flight Test Handbook	1984
AFFTC-TIH-83-2	Lush, K.L.	Hydraulic Subsystems Flight Test Handbook	1983
AFFTC-TIH-82-2	Lush, K.L.	Environmental Control Subsystems Flight Test Handbook	1982
AFFTC-TIH-81-6	Jones, L.W.	Development of Curves for Estimating Aircraft Arresting Hook Loads	1982
NATC-TM-79-33SA	Chapin, P.W.	A Comprehensive Approach to In-Flight Thrust Determination	1980
NATC-TM-79-3SY	Schiflett, S.G. Loikith, G.J.	Voice Stress Analysis as a Measure of Operator Workload	1980
NASA-CR-3406	Bennett, R.L. and Pearsons, K.S.	Handbook on Aircraft Noise Metrics	1981
—	—	Pilot's Handbook for Critical and Exploratory Flight Testing. (Sponsored by AIAA & SETP — Library of Congress Card No.76-189165)	1972
—	—	A & AEE Performance Division Handbook of Test Methods for assessing the flying Qualities and Performance of Military Aircraft. Vol.1 Airplanes (A/L 9 1989)	
A & AEE Note 2111	Appleford, J.K.	Performance Division: Clearance Philosophies for Fixed Wing Aircraft	1978
A & AEE Note 2113 (Issue 2)	Norris, E.J.	Test Methods and Flight Safety Procedures for Aircraft Trials Which May Lead to Departures from Controlled Flight	1980
A & AEE ARM 1014/03	—	A & AEE Armament Division Handbook of Test Methods	