

ADVANCES IN LIGHTNING PROTECTION THAT SATISFIES CONTEMPORARY STANDARDS

by Roy B. Carpenter, Jr. of LEC, Inc.
Boulder, Colorado

INTRODUCTION

Recent years have experienced a flurry of activity in lightning protection circles and protection technology. Most of the development in protection technology has been limited to some form of electrical and electronic circuit protectors. However, there has been some activity in the stroke protection field. Most of these have involved "bigger and better" stroke collectors (air terminals), including the radioactive variety. One or more of these developments resulted in low impedance down conductors.

All except one company has been concentrating in the field of what may be termed a "Collector-Diverter" System in some form. In contrast, LEC, Inc. of Boulder, Colorado has developed a lightning strike prevention system and has successfully completed installation of over 1000 systems in many of the lightning active areas of the world. That system is known as the Dissipation Array® System (DAS®). Although the DAS has achieved an impressive record for preventing strikes to large areas and tall structures, it has not yet been included in any of the recognized standards such as NFPA-76 or UL 96. There are many reasons given why the DAS is not part of an accepted standard but perhaps the most valid reason is that there is no standard that provides for such a revolutionary concept. All standards provide for stroke collection; the DAS facilitates stroke prevention. The demands on system design are, therefore, significantly different. To resolve that problem and provide a stroke prevention system that does qualify under UL 96, LEC has developed an Ionizer (the main component of the DAS) that also qualifies as an air

terminal. Further, it is a far more effective air terminal if used alone. This paper describes the LEC Spline Ball Ionizer® (SBI) and the Spline Ball Terminal™ (SBT) families and how their use in a conventional lightning protection system can achieve strike prevention in a conventional setting.

LIGHTNING AS IT INFLUENCES A PROTECTION SYSTEM

Lightning is usually initiated by a downward moving channel of charge starting from the cloud and moving toward the earth in steps. These channels are termed "Step Leaders" because they move in steps. As these channels or leaders move toward the earth, the electrostatic field between them and earth-bound objects rises rapidly.

The primary question is "where will that step leader terminate?" To that end, a great deal of research has been accomplished and recorded. It seems that the stroke termination is a function of two definable factors in addition to random chance.

RANDOM CHANCE we are told determines the path the leader will take until that leader reaches the "Point of Discrimination". Refer to Figure 1.

THE POINT OF DISCRIMINATION is that point in the leader descent path where the strike point is determined; and is also the beginning point of the last step. It is, therefore, about one full step from earth. This distance is also referred to as the "striking distance".

THE STRIKING DISTANCE is the length of the path between the Point of Dis-

crimination and any potential strike terminus regardless of direction. It may also be considered the maximum distance between the tip of the leader and the stroke terminus. The Striking Distance and the step length are approximately the same value. Both are statistical quantities dependent on the intensity of the ensuing lightning strike. These values are estimated via Figure 2. Note that these steps and the striking distances vary from a low of approximately 20 meters to a high in excess of 200 meters. However the average is only about 20 meters for a negative stroke which is the most common. For a positive stroke, the average exceeds 45 meters.

Placing these data in perspective, we know that after the leader reaches the Point of Discrimination the strike point has been determined. Before that time, the path is random and indeterminate. Therefore, only the objects or facilities within the strike zone are at risk. As illustrated in Fig. 1, a tall tower can be just outside the strike zone and not take a strike while a blade of grass within the strike zone could be struck. Upward moving streamers tend to "compete" for the downward moving leader; the first to connect closes the circuit creating the flash channel.

Pertinent to this paper is the occasional horizontal paths taken by some leaders. When leaders approach a structure at some angle, the approaching leader creates a high electrostatic field between. This causes the potential to rise high enough to stimulate any discontinuity to pass into the streamer mode. That streamer may then "reach out" and collect the leader causing sharp changes in the leader path. Often 90 degree turns have been observed to be caused by this phenomena.

CONVENTIONAL COLLECTORS
(AIR TERMINALS)

Conventional collectors or air terminals are devices deployed to intercept an incoming step leader and divert the related energy to earth by some preferred path. Lightning rods are typical of these units and the most widely used.

These rods take on various configurations from pointed to blunt and some times offer several secondary points. The usual application calls for the rods to be mounted in such a way that they will collect a stroke entering their cone of protection. Refer to Figure 3. In practice we find that the so called "Cone of Protection" assumption is never 100 percent effective. Cones of even 10 degrees have been used with varying degrees of success. It appears that the smaller volume of the assumed cone of protection, the more effective it is in collecting the stroke leader if the height is not significant. Because the cone of protection theory has proven ineffective, the utility industry moved to the "Rolling Sphere" concept also illustrated. This reduced the assumed "protected volume" significantly and appears to more accurately describe the protected volume, but is still not 100% true.

The foregoing limitation can best be understood from Figure 4. Industry standards are based on the premise that the collecting volume is described as a cone of 45 degrees around the vertical centerline of the air terminal for a full 360 degrees in azimuth. However, it appears that Figure 5 more closely approximates the air terminal's collection capability. This is a function of the inability of the air terminal to propagate effective streamers as the angle from the vertical increases. This also explains why tall structures are often struck below the top.

HYBRIDS (DISSIPATING AIR TERMINALS)

As used herein, a hybrid air terminal is one that primarily functions as an Ionizer, but when saturated, "fails" as an air terminal. In addition, when properly designed, properly deployed and used in some quantity, they will function as a DAS® and conceivably approach 100 percent effectiveness as a stroke prevention system.

The LEC Spline Ball Ionizer® (SBI) and the Spline Ball Terminal™ (SBT) were developed as an optimized hybrid air terminal. Figures 6 and 7 illustrate the two configurations. Both the SBI and SBT provide the required point spacing to maximize the ionization current. At the same time they provide a point oriented for at least every 5 degrees in azimuth for the full 360 degrees and a full 120 degrees in elevation. As a result, there is no direction from which a leader can approach that would not have a collective point oriented directly toward it and many backup points close by.

Both the SBI and SBT have been reviewed by Underwriters Lab and have been listed as Air Terminals, usable as such in any UL 96 based lightning protection system where UL listed terminals are specified.

USING THE SBI AND SBT IN STANDARDS BASED SYSTEMS

Standards such as NFPA-78, UL96A, NAV FAC DM4, Army 385-100 are based on the use of a single point lightning rod known as the air terminal or some other form of stroke collector. However, since UL has listed the SBI and SBT, these assemblies can be used in place of the single point terminal. In most cases they can be used as a direct replacement. The SBT is designed to fit into the conventional lightning rod mounting plate.

Figure 8 illustrates a typical NFPA-78 building protection system that has been converted to a Hybrid Stroke Pre-

tection System. Model SBT-24 hybrids are used in the required locations around the periphery. The Model SBI-48 hybrids are used in the required locations down the middle of the building.

In addition to the standard demands, location and separation distance between SBT or SBI's are a function of two factors:

1. The percentage of strokes to be eliminated (an energy related factor), and
2. The potential strike zone physics.

All are traced off against cost. Of particular concern to this paper is the criteria for the location and spacing of the SBT for successful operation as an air terminal.

As general criteria:

1. For a system that must satisfy UL 96A and/or other standards, the SBT-24 is 24 inches high and may be used as described by the following:
 - a. Space each SBT 25 feet apart, but no more than 2 ft. from the edge of the facility.
 - b. Space each row of SBT's no more than 50 ft. apart.
 - c. Interconnect rows at no more than 50 ft. intervals
 - d. Ground each row at least every 100 ft.

2. For a non-standard, Collector-Diverter Concept based on the SBT, the following rationale may be applied:

NOTE: A non-standard system is one based on the premise that a standard per se does not need to be satisfied. It also follows that since the numbers of SBT's required are reduced, the dissipation capability is reduced and the major protection mode may be that of a collector-diverter concept instead of a DAS.

The object of a Collector-Diverter system is to provide an efficient collector and a safe diversionary path. The diversionary path parameters are defined by UL 96A and 1.d above.

The collector efficiency is related to its ability to produce streamers that will propagate toward the downward moving leader as it approaches the Point of Discrimination. As illustrated in Figure 1, the Strike Zone for that leader is a discrete volume dependent entirely on the energy in the leader. High energy leaders have strike distances of up to 180 meters for the common negative polarity and as short as about 15 meters. Positive stroke distances are much longer. From these data it is evident that to provide a 100 percent effective collection function, the SBT must be within the strike zone of the lowest energy leader and it must be the most prominent streamer generator within that zone.

The design problem is related to the site situation as well as the facility. Since the potential between the leader tip and the closest streamer generator (point or sharp edge) will be highest, it will be the stroke terminus. This premise is true only if there are no other streamer generating objects close enough to compete with it.

Based on the foregoing, and the desire to collect the weakest stroke, it would appear that a separation distance equal to the strike distance would be the maximum safe separation. Therefore, a spacing of no more than 15 meters or approximately 50 ft. should be safe. However, a 40 ft. separation would offer a margin of safety.

A properly completed standards based system which is composed of the LEC Spline Ball Ionizer® hybrid system

and will provide us with two modes of protection:

1. A stroke prevention mode that reduces the risk of a strike to the protected facility in proportion to the size of that facility, the size and number of SBI/SBT's used.

NOTE: When the SBT/SBI based system is used and the number of units are in the order of 100 or more, the risk of a strike should be less than one chance in 1000. That is equal to a DAS.

2. A Stroke Collector-Diverter System that is far superior to any system now in use because it collects strokes entering the "protected" area from any direction and angle.

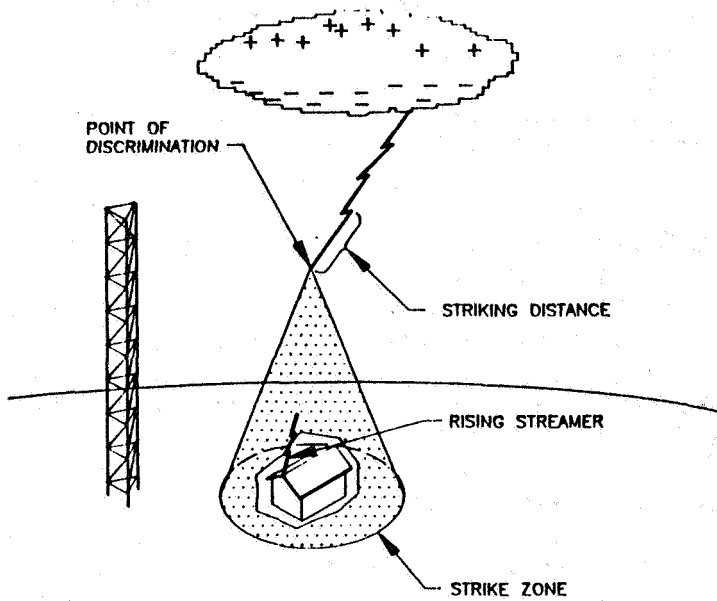

FIGURE 1, THE STROKE PATH FACTORS

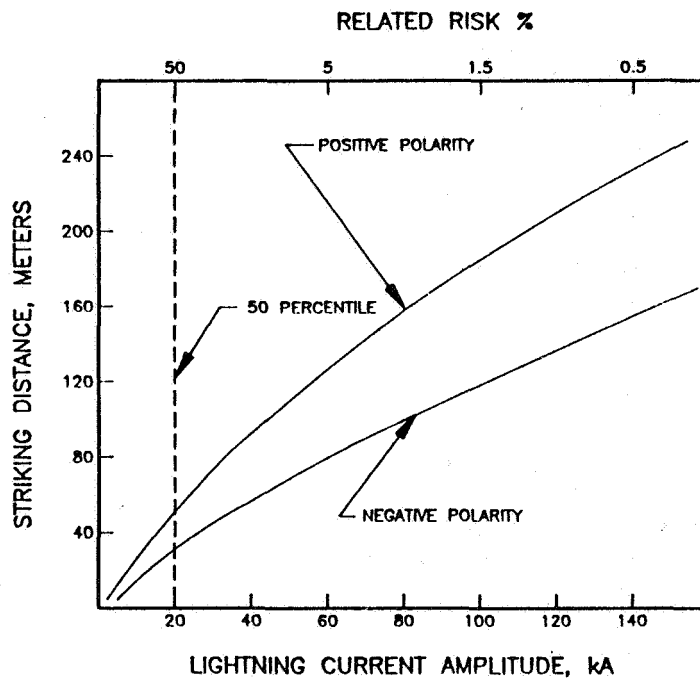

FIGURE 2, STRIKING DISTANCES OF NEGATIVE AND POSITIVE LIGHTNING STROKES

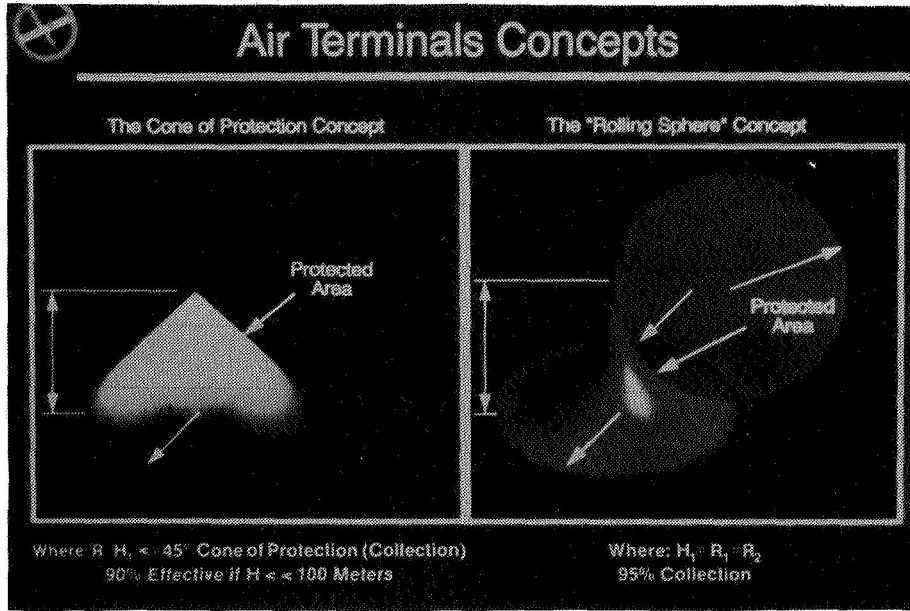

FIGURE 3.

STROKE COLLECTION EFFICIENCY CONVENTIONAL AIR TERMINAL

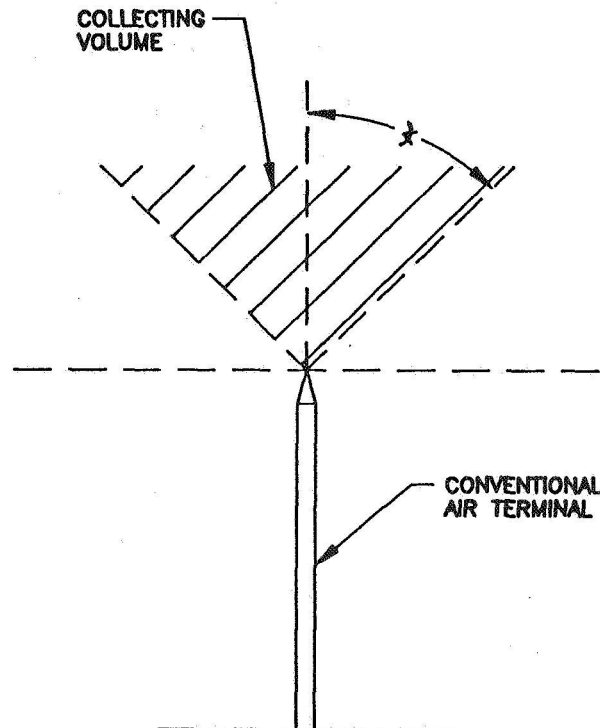

FIGURE 4.

STROKE COLLECTION EFFICIENCY CONVENTIONAL AIR TERMINAL

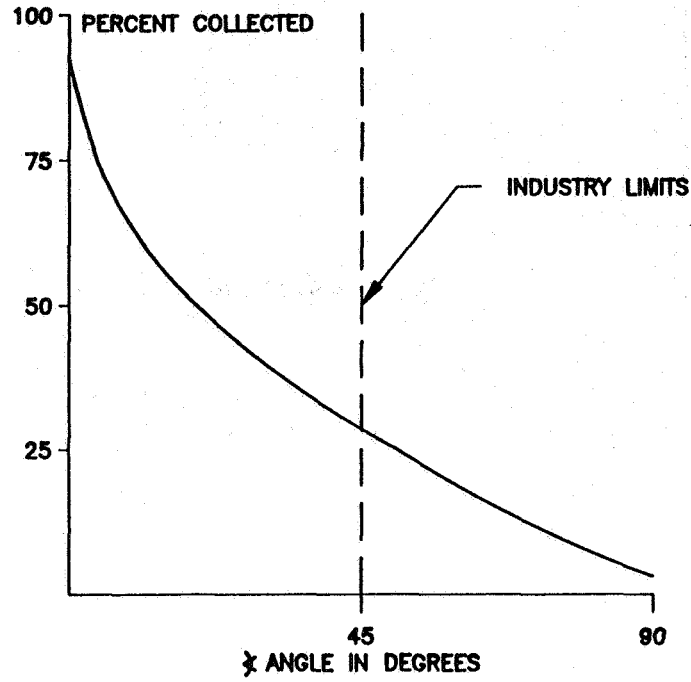

FIGURE 5.

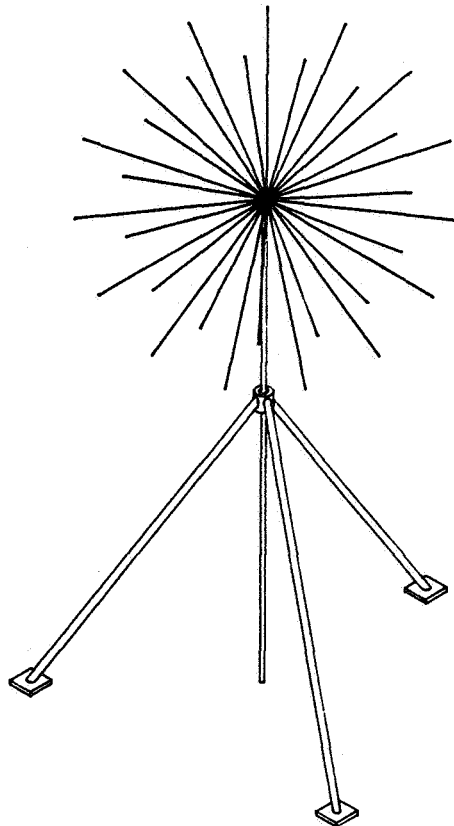

FIGURE 6: SBI ON TRIPOD

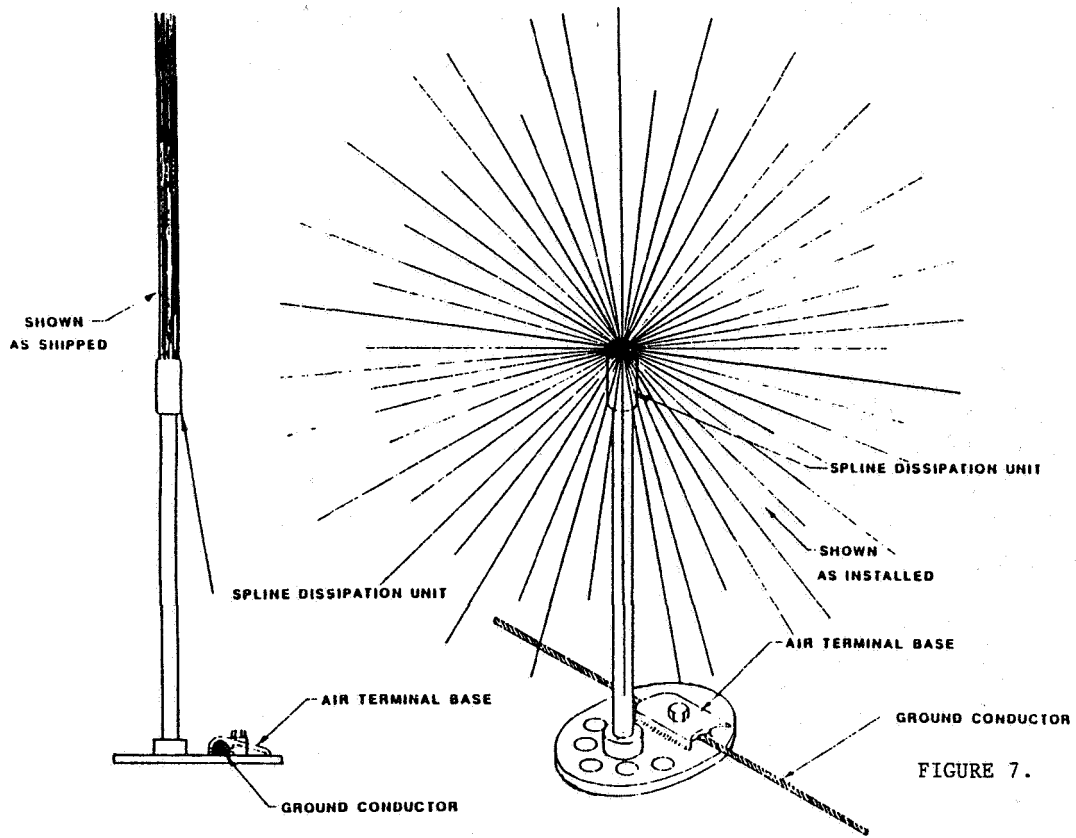

FIGURE 7.

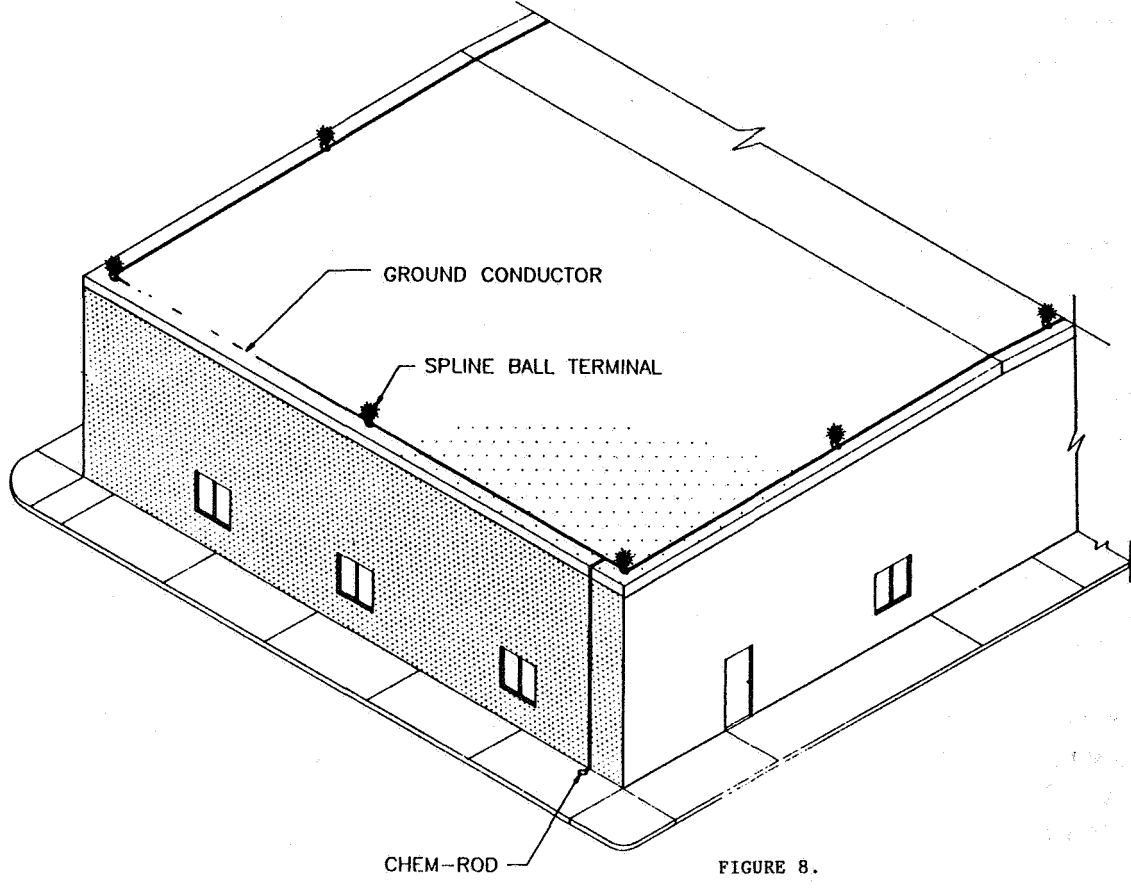

FIGURE 8.