

NASA Technical Memorandum 105318

11-28  
63161  
PB

# Overview of Rocket Engine Control

(NASA-TM-105318) OVERVIEW OF ROCKET ENGINE  
CONTROL (NASA) 13 p CSCL 214

N92-13274

Unclas  
65/20 0053161

**Carl F. Lorenzo and Jeffrey L. Musgrave**  
*Lewis Research Center*  
*Cleveland, Ohio*

Prepared for the  
Ninth Symposium on Space Nuclear Power Systems  
sponsored by the University of New Mexico  
Albuquerque, New Mexico, January 12-16, 1992

The NASA logo, consisting of the word "NASA" in a bold, sans-serif font.



# OVERVIEW OF ROCKET ENGINE CONTROL

Carl F. Lorenzo and Jeffrey L. Musgrave  
National Aeronautics and Space Administration  
Lewis Research Center MS 77-1  
Cleveland, OH 44135

## Abstract

This paper broadly covers the issues of Chemical Rocket Engine Control. The basic feedback information and control variables used in expendable and reusable rocket engines, such as the Space Shuttle Main Engine are discussed. The deficiencies of current approaches are considered and a brief introduction to Intelligent Control Systems for rocket engines (and vehicles) is presented.

## INTRODUCTION

The purpose of this paper is to give a broad overview of Chemical Rocket Engine (CRE) control as background for Nuclear Thermal Rocket Engine control. The paper will discuss the fundamental (underlying) physical issues in CRE control. A brief discussion of modern CREs and their control will follow. This will include a discussion of the Space Shuttle Main Engine (SSME). Recent advanced control approaches for the SSME will be presented along with the benefits which ensue. Current research into Intelligent Control Systems for the SSME which allows high levels of adaptability to engine degradations will be discussed. Finally the connections of current chemical rocket engine controls research to nuclear rocket controls will be explored.

## FUNDAMENTALS OF CHEMICAL ROCKET ENGINE CONTROL

The fundamentals of CRE control are best explained by starting with a simplified configuration (Figure 1). This pressure fed rocket engine supplies propellants through appropriate feedlines, control valves and injector elements to a main combustion chamber by pressurizing the supply tanks. The chamber requires the propellants to be delivered in a predetermined ratio (mixture ratio), defined as

$$MR = \frac{\dot{w}_{ox}}{\dot{w}_{fuel}} \quad (1)$$

and at a flow rate level related to the desired thrust. The fundamental function of a rocket engine control is to control thrust (inferred by chamber pressure) and the mixture ratio. The mixture ratio is important since for any propellant combination and pressure level, it sets the combustion temperature and hence the performance and the maximum material temperature. It is also important in terms of propellant utilization.

The basic dynamic equations are found in (Lee et al. 1953). The chamber pressure ( $P_c$ ) to total weight flow ( $\dot{w}_T$ ) transfer function is given by

where ( $c^*/A_T g$ ) is a proportionality constant,  $\sigma$  is the combustion delay and  $\tau$  is the chamber fill time ( $\tau \sim c^* A_T g V_c / RT_c$ ) where  $c^*$  is the characteristic exhaust velocity,  $A_T$ ,  $T_c$ , and  $V_c$  represent the throat area, combustion temperature, and

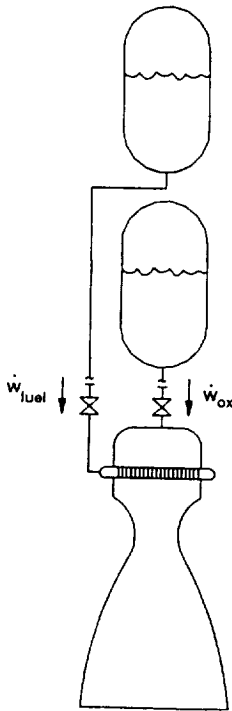

FIGURE 1. Pressure Fed Bi-Propellant Rocket Engine Schematic.

$$\frac{P_c(s)}{\dot{w}_T(s)} = \left( \frac{c^*}{A_T g} \right) \left( \frac{e^{-\sigma s}}{\tau s + 1} \right) \quad (2)$$

main chamber volume respectively. In linear form the injectors are flow resistors so that

$$\dot{w}_T(s) = \dot{w}_{fuel}(s) + \dot{w}_{ox}(s) = k_1(P_{i_{fuel}}(s) - P_c(s)) + k_2(P_{i_{ox}}(s) - P_c(s)) \quad (3)$$

where  $P_i$  is the injector pressure. The feedline can be represented in lumped parameter form (continuity and momentum equations) or distributed hyperbolic form (wave equation). In this configuration there are two inputs, namely the valve areas (positions) which control the individual propellant flows and hence the chamber pressure and mixture ratio.

A classical control for this simplified configuration is shown in Figure 2. The following observations are made. Chamber pressure responds to total weight flow. Therefore the chamber pressure flow loop would usually (but not necessarily) go with the propellant having the higher flow rate say  $O_2$  in an  $H_2 - O_2$  engine. Also the two loops tend to be interactive and to minimize excursions of the error signals, one loop is tuned to be the "fast" loop and the other slower. Experience shows that the mixture ratio should be the fast loop. This minimizes excursions in MR away from the set point which in turn keeps the gas and metal temperatures at the design conditions. The chamber pressure is the "slower" loop and its bandwidth is set by thrust response requirements. The type of control shown here would normally require three measurements

$P_c$ ,  $\dot{w}_{fuel}$ , and  $\dot{w}_{ox}$  with two control inputs (valve areas)  $A_{fuel}$  and  $A_{ox}$ . These basic ideas dominate CRE control design for much more complex cycles.

### MODERN CHEMICAL ROCKET ENGINES

Turbine driven pumps supply the propellants in most modern rocket vehicles. Numerous cycles are proposed, studied, and used in regard to the method that the turbines are powered. The various engine cycles each have their benefits and problems and a discussion of these is well beyond the scope of this paper.

Two representative cycles will be considered. The first of these is the Gas Generator Cycle (Figure 3). The fundamental feature of this cycle is that small amounts of propellant are taken from the main propellant feedlines to be burned in a small auxiliary combustor (gas generator). The generated gases power the turbopumps, and may be used to cool the nozzle and are expelled. The most likely mode of control for this cycle would be to regulate chamber pressure by controlling the gas generator pressure. This would control the speed of both turbopumps and hence the total propellant delivered to the main combustion chamber. Either the oxidizer valve or fuel valve (or both depending on cycle design) could be used to control mixture ratio as the fast loop. From a high level perspective, this control philosophy is very much the same as that detailed in the previous section. In the small, the control designer must assure that the local mixture ratio of the gas generator is controlled to assure gas generator and turbine integrity. Also the flow/power balance between the two turbopumps, that is the propellant delivered by each turbopumps at a given gas generator conditions together with the main chamber cooling requirements will likely determine which main propellant valve will be used to control main chamber mixture ratio.

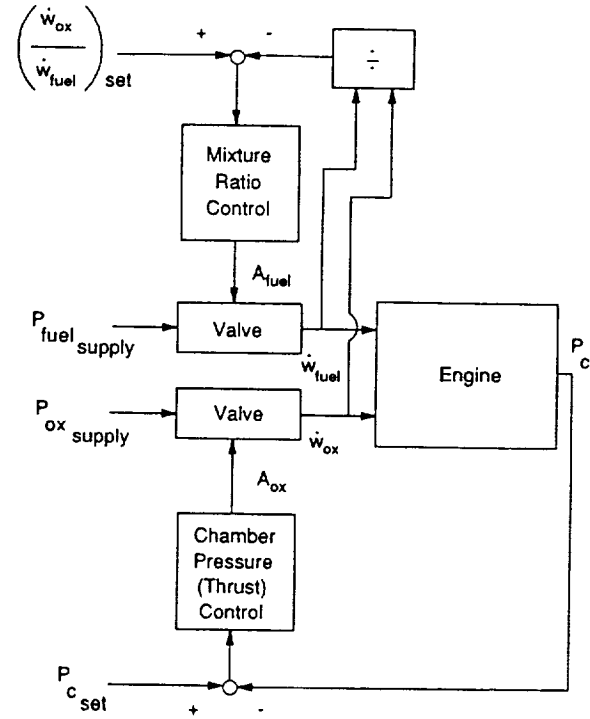

FIGURE 2. Classical Control for Bi-Propellant Rocket Engine.

The second cycle considered is the Expander Cycle (Figure 4). Here, one of the propellants (usually fuel) is circulated as a coolant through the combustion chamber and nozzle. This heated fuel is used to power the turbopumps and then returned to the main chamber where it is injected and burned to create thrust. Note in this cycle most of the fuel is circulated through the turbine. From a controls point of view, this cycle is very similar to the previous cycle. However, overall propellant delivery is set by pump speed which in turn is set by the turbine bypass valve. The oxidizer valve provides control over mixture ratio.

Generally speaking, classical control can be used to design for adequate  $P_c$  and MR control provided loop speeds (bandwidths) are properly accounted. Sensing requirements for  $P_c$  and MR performance are minimal, usually being chamber pressure and propellant mass flows.

This discussion does not include treatment of startup or shutdown. Startup is usually a scheduled process based on empirical knowledge of initial ignition, propellant arrival times, and related parameters. Shutdown is also a critical part of the process which must be accurately executed to realize the required mission delta velocity requirement.

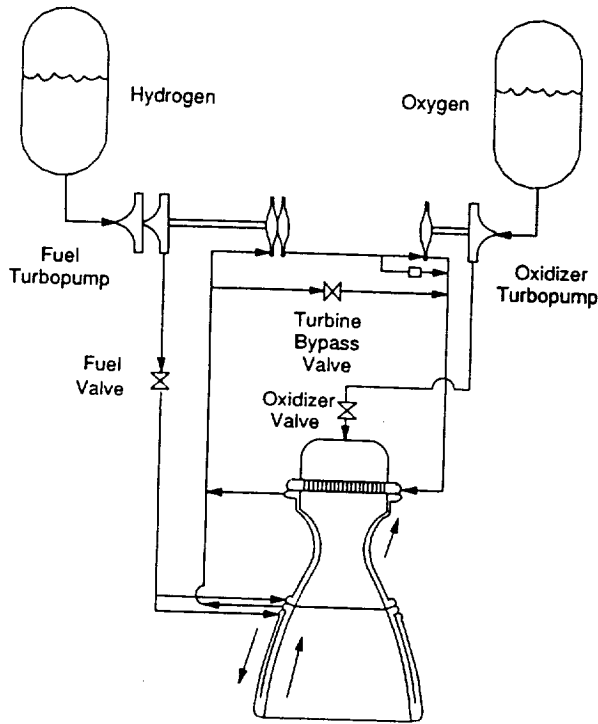

FIGURE 4. Full Expander Cycle Rocket Engine Schematic.

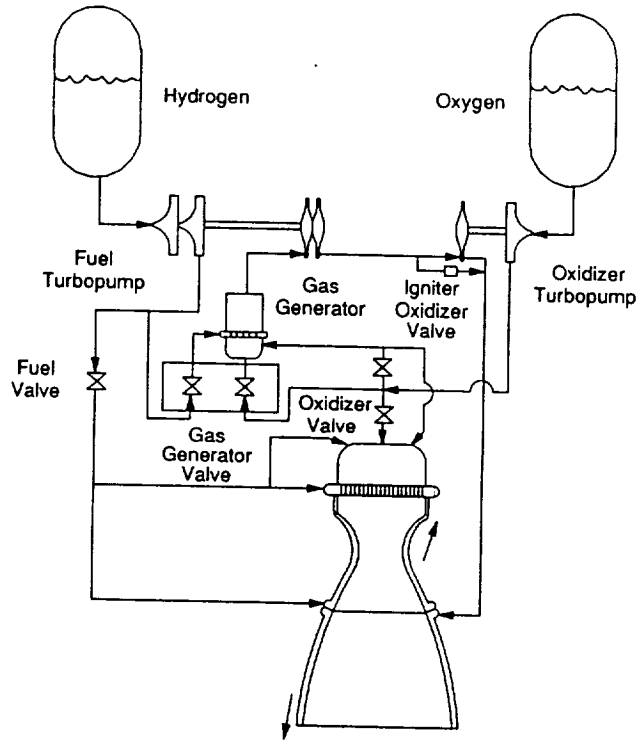

FIGURE 3. Gas Generator Cycle Rocket Engine Schematic.

Many variants of these cycles are possible, and the selection of a cycle for any particular vehicle involves a broad set of considerations such as mission, reliability, manned or unmanned, and maintenance times. However, the high level control philosophy is similar in all cases.

### SPACE SHUTTLE MAIN ENGINE CONTROL

The SSME is the first large scale reusable rocket engine developed from a long line of expendable liquid rocket propulsion technology. A two stage combustion process provides the necessary fuel and lox supply pressures to reach the 20684 kPa (3000 psia) chamber pressure resulting in 2091 kN (470,000 lbs) of rated (vacuum) thrust. A propellant flow schematic of the SSME is shown in Figure 5. Hydrogen used to cool the Main Combustion Chamber drives the Low Pressure Fuel Pump (fuel supply) while bleed flow from the High Pressure Lox Pump drives the Low Pressure Lox Pump (lox supply). The fuel and lox preburners acting as the first stage of the combustion process drive the High Pressure Turbopumps which supply coolant flow and lox for the main combustor respectively. The fuel rich gas from the preburners is burned again as primary fuel in the main chamber.

Engine control is accomplished through five valves shown in Figure 5, that is Main Oxidizer Valve (MOV), Main Fuel Valve (MFV), Coolant Control Valve (CCV), Oxidizer Preburner Oxidizer Valve (OPOV), and Fuel Preburner Oxidizer Valve (FPOV). In the actual SSME controller (Baseline control), only FPOV and OPOV are used as closed loop control valves. To analytically explore the benefits of enhanced controllability (Musgrave 1991) added the Oxidizer Preburner Fuel Valve (OPFV) and considered the remaining

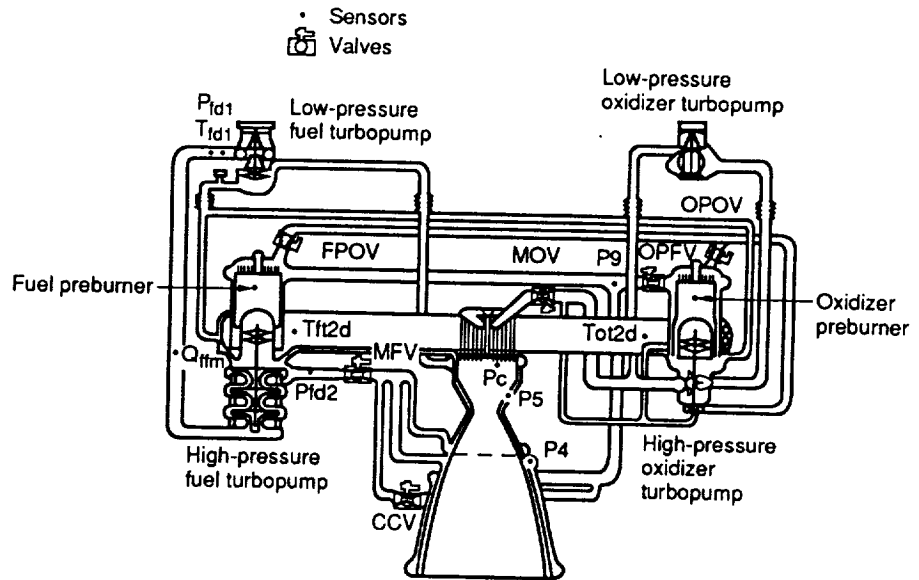

Figure 5. Space Shuttle main engine flow schematic modified by addition of OPFV.

valves to also be closed loop control valves. This actuator configuration is used in the multivariable control (MVC) comparison with the SSME Baseline control which follows the discussion of the baseline controller.

A number of measurement locations are shown in Figure 5 which represent a subset of the SSME ground test sensor suite. Note that the measurements shown are not necessarily Baseline engine control sensors. The discharge pressure and temperature of the Low Pressure Fuel Turbopump ( $P_{fd1}$  and  $T_{fd1}$  respectively) as well as volumetric fuel flow ( $Q_{fm}$ ), and  $P_c$  are used for estimating MR in the existing SSME Baseline controller. The discharge pressure of the High Pressure Fuel Turbopump ( $P_{fd2}$ ), the discharge temperatures of the High Pressure Fuel and Lox Turbines ( $T_{ft2d}$  and  $T_{ot2d}$  respectively), the pressure of the Fixed Nozzle Heat Exchanger ( $P_4$ ), the pressure of the Main Chamber Heat Exchanger ( $P_3$ ), and the fuel supply pressure of the preburners ( $P_9$ ) are used in conjunction with  $P_c$  form the sensor suite for the MVC control to be discussed below.

Engine startup and shutdown are accomplished through open loop scheduling based on extensive computer simulation and test experience. The startup process for a chemical rocket engine is extremely complex and definitive dynamic models have not been created to describe this behavior. Thus, closed loop control has not been attempted in this domain and scheduled valve openings and ignition timing are employed. Closed loop control of the SSME is done via Proportional-Integral (PI) control. A multivariable control approach has been demonstrated in digital computer simulation.

### Baseline Controller

The actual SSME controller (Baseline) design philosophy with PI control of  $P_c$  and of MR is similar to that discussed for the cycles of Figures 3 or 4. Setpoint control of  $P_c$  provides throttling while setpoint control of MR maintains performance and temperature in the main combustion chamber. Regulation of lox flow into the lox preburner and fuel preburner via OPOV and FPOV respectively, adjusts the High Pressure Pump discharge pressures which determine  $P_c$  and MR in the main chamber. Lox flow into the lox preburner has an impact on both  $P_c$  and MR while lox flow into the fuel preburner has a larger affect on MR only which allows for independent control of both parameters. The CCV is open loop scheduled based on commanded  $P_c$ , MOV and MFV are full open, and OPFV is not available on flight hardware making direct control of preburner O/F impossible. Proportional-Integral control has wide acceptance due to the simplicity of design (two parameters), ease of implementation, and speed of computation.

A typical throttle down transient maneuver is shown in Figure 6. The dashed line in Figure 6a represents commanded  $P_c$  while the dotted line is the closed loop response for the Baseline control. The Baseline controller

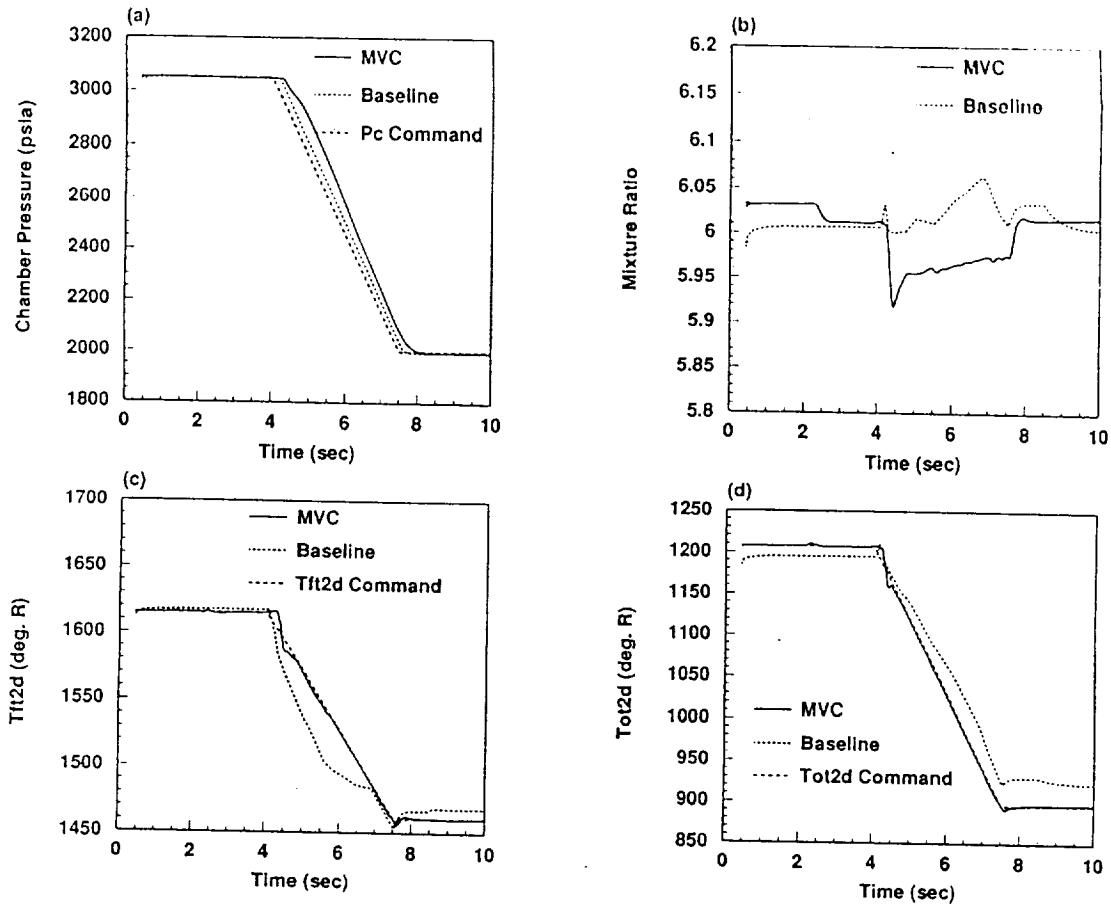

Figure 6. Comparison of Baseline and MVC Responses for the Throttle-Down Transient.

achieves excellent tracking of commanded  $P_c$  while minimizing MR excursions from the design point ( $MR = 6.011$ ) as shown by the dotted line in Figure 6b. The "uncontrolled" turbine discharge temperatures are included in Figures 6c and 6d for the purpose of comparison with the multivariable control later.

Control of  $P_c$  and MR only indirectly manage the operation of the four turbopumps which are important life limiting components in the SSME (Cikaneck 1987). That is, preburner mixture ratios (temperature) are not directly regulated. This fact may be important relative to the engines not achieving their design life-times. Turbine discharge temperature redlines are used by the Baseline controller to shutdown the engine. Figure 7 shows the closed loop engine response resulting from a change in the High Pressure Fuel Turbine efficiency during mainstage operation. Here, a step decrease of 10% in High Pressure Fuel Turbine efficiency occurs at  $T = 4$  sec while setpoints on  $P_c$  and MR are kept constant at design chamber pressure and mixture ratio. The dotted line (Baseline controller) in Figure 7a shows a slight spike in  $P_c$  while MR experiences a large increase before returning to setpoint resulting in a temperature spike in the main combustion chamber which is not shown here. The dotted line in Figure 7c shows the discharge temperature of the High Pressure Fuel Turbine rapidly approaching the redline cutoff while Figure 7d shows a rapid drop in High Pressure Oxidizer Turbine discharge temperature. In the next section, the benefits of multivariable control for rocket engines will be discussed in the context of these two examples.

### Multivariable Controller

Multivariable control (MVC) methods generally rely on linear state space models of the process to be controlled. A perturbation model of a simplified (39 state) nonlinear dynamic engine model at rated power was used for control design (Musgrave 1991). The linear models of the SSME change very little from the 65% to the 109% power (thrust) level, therefore gain-scheduling was not required.

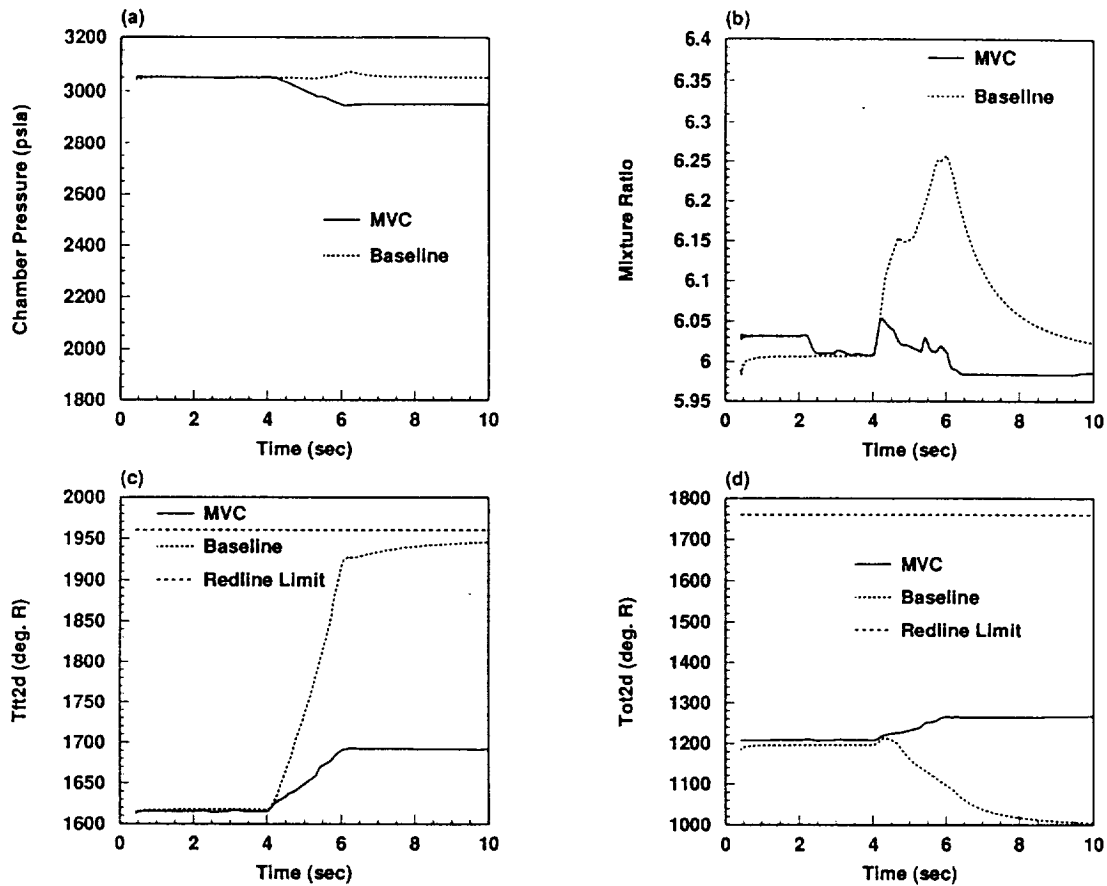

FIGURE 7. Comparison of Baseline and MVC Responses for a 10% Drop in Fuel Turbine Efficiency.

MVC allows the integration of multiple objectives of  $P_c$ ,  $Mr$ ,  $Tft2d$ , and  $Tot2d$  command following while decoupling each of the loops from the others using all six valves in Figure 5 as control valves. Figure 6 shows a multivariable design running at the same sampling rate as the Baseline control (50 hz). The solid line of Figure 6a represents the closed loop MVC response of  $P_c$  to reference commands (dashed line). The Baseline controller (dotted line) achieves slightly tighter  $P_c$  control than does MVC, however both are satisfactory. Control of  $MR$  (solid line) in Figure 6b compares favorably to the Baseline controller with excursions below the setpoint (cool side). The solid lines of Figures 6c and 6d demonstrate the command following capability of the MVC for  $Tft2d$  and  $Tot2d$  (solid lines) to reference commands (dashed lines).

The benefit of MVC is demonstrated for 10% decrease in High Pressure Fuel Turbine efficiency. In all cases for the MVC of Figure 7 as with Baseline, reference commands for  $P_c$ ,  $MR$ ,  $Tft2d$  and  $Tot2d$  are kept constant at their respective 100% power values. In Figure 7a, we see the controller automatically allowing a slight decrease (3%) in delivered chamber pressure while maintaining mixture ratio (solid line in Figure 7b) thereby avoiding temperature excursions in the main chamber. The dramatic increase (21.9%) of  $Tft2d$  from Baseline in Figure 7c is reduced by the MVC to only a 6.25% increase in temperature. This action will preserve the turbine blade life and avoid an unnecessary redline shutdown. Finally, Figure 7d shows only a slight change in  $Tot2d$  for the MVC (solid line) compared to the dramatic decrease of the Baseline control (dotted lines). Consequently, the MVC is capable of avoiding a potential redline cutoff which could compromise the mission and/or result in further damage to engine components.



## NEW DIRECTIONS

### Rocket Engine Intelligent Control

The SSME (Figure 5) is the first rocket engine designed with a philosophy of reusability. The harsh environment encountered in this engine has not allowed realization of the 55 mission design life. Numerous durability problems have been documented for the SSME (Cikanek 1987). These facts together with a desire to space-base some newer rocket engines motivates a technology thrust (Merrill and Lorenzo 1988, and Lorenzo and Merrill 1990) toward Reusable Rocket Engine Intelligent Control. The basic concept of rocket engine Intelligent Control is that using advanced sensors (condition monitoring instruments) and on-board diagnostic/prognostic and coordination intelligence an engine with an Intelligent Control System (ICS) can detect and accommodate various sensor, actuator and engine hardware failures. The key functionalities of an ICS are: life extending control, adaptive control, real-time engine diagnostics and prognostics, component condition monitoring, real-time identification, and sensor/actuator fault tolerance. Artificial intelligence techniques are considered for implementing coordination, diagnostics, prognostics, and control reconfiguration functionalities.

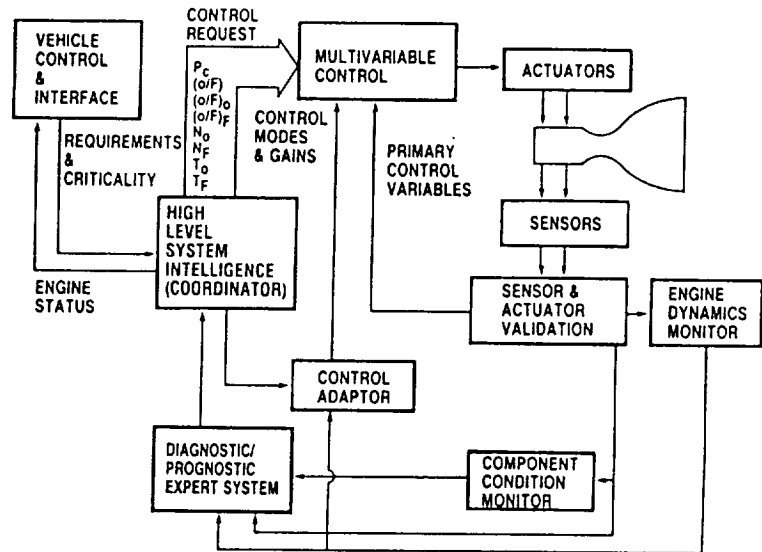

FIGURE 8. REUSEABLE SPACE PROPULSION INTELLIGENT CONTROL SYSTEM FRAMEWORK.

A framework for an ICS is shown in Figure 8. The framework provides a rational, top-down basis for the incorporation of system intelligence through the hierarchical integration of the control functional elements. This hierarchy integrates functionalities at the execution level such as the high-speed, closed-loop multivariable controller, engine diagnostics and adaptive reconfiguration with a top level coordination function. The top level coordination function serves to interface the current engine capability with the other engines in the propulsion system, the vehicle/mission requirements, and the crew. It modifies controller input commands and selects various control reconfiguration modes to resolve any conflicts between objectives. A practical baseline framework expanding these ideas for an SSME based Intelligent Control has been proposed (Nemeth 1990). An advanced framework for SSME Intelligent Control is given (Nemeth et al. 1991). The promise of intelligent control is an engine system with greater durability and operability in the face of impending or actual component failure.

### Life Extending Control

The concept of Life Extending Control (LEC) compliments that of Intelligent Control discussed above. In LEC the object is to minimize damage accumulation at critical points of the (engine) structure by the way in which the control moves the system through transients (or by the choice of operating domain). Such a concept must also maintain required dynamic performance. In contrast to Intelligent Control, LEC represents what can be done to enhance system durability through the direct control level. LEC is an interdisciplinary thrust between controls and materials/structural science (in particular, fatigue fracture mechanics).

Two broad classes of LEC have been conceptualized by (Lorenzo and Merrill 1991). These are Implicit LEC which uses current technology cyclic based fracture/fatigue damage laws and the Continuous Life Prediction approach which assumes development of continuous differential forms of the damage laws. Only the Implicit LEC concept will be discussed here in order to expose the basic ideas.

The implicit approach to LEC recognizes that current fracture/fatigue science can not predict the differential damage on less than a full cycle of strain. The implicit approach (see Figure 9) selects a sequence of typical command transients (and disturbances) that are representative of those the system would experience in service. Two

performance measures are defined:  $J_p$ , an objective function that maximizes dynamic performance (possibly by minimizing quadratic state and control excursions) and  $J_D$ , a damage measure which uses the best (current) fatigue/fracture theory available to calculate the damage accumulated over the sequence of command transients. An overall performance measure can be defined as  $J = J_p + a J_D$  where  $a$  represents the relative importance between performance and life extension. The implicit approach then selects a "best" control algorithm which is applied for the full sequence of command transients. The dynamic performance and damage accumulation over the sequence are optimized (relative to the selected measures) against the control algorithm parameters. The expectation is to find an algorithm such that the loss in dynamic performance is small ( $J_{p,z,min} - J_{p,o,min}$  in Figure 10), for a significant reduction in accumulated damage over the sequence of transients ( $J_{D,o,min} - J_{D,z,min}$  is large and life is extended). Here the subscript "o" refers to optimizing for dynamic performance only. An actual operating gain set (point q in Figure 10) is then chosen which satisfies the desired weighting between performance and damage (J).

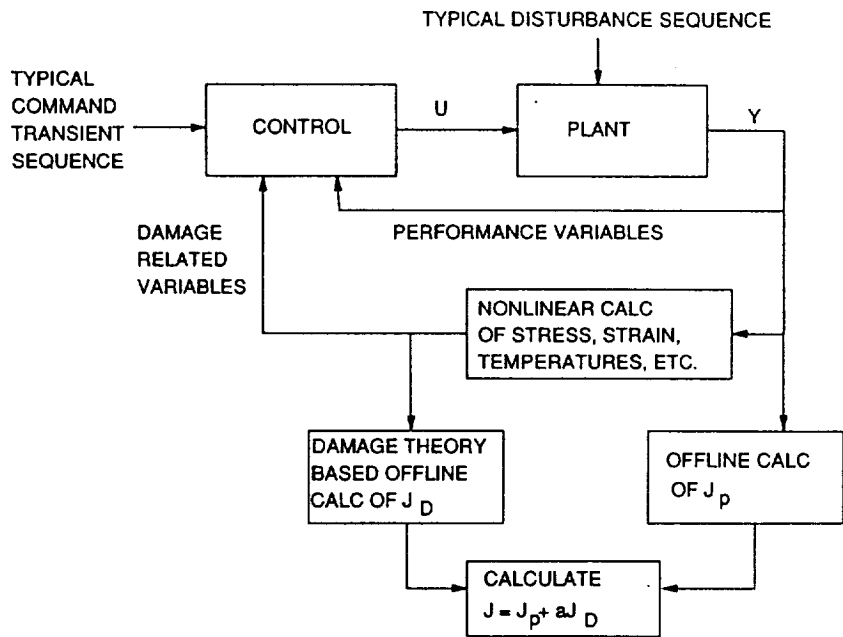

FIGURE 9. Implicit Life Extending Control Approach.

The mechanics of the implicit approach are detailed as follows. During the design process, two types of feedback variables are considered: (1) the performance variables normally used to manage dynamic performance and (2) nonlinear functions of the performance variables representative of the damage variables (stresses, strains, temperature, and various rates). Various control algorithms are then examined within this feedback structure. That is, the sequence of selected performance and disturbance transients are applied to a simulated system with a trial control and performance J (or  $J_p$  and  $J_D$  separately) is calculated. A family of algorithms can be developed which are parameterized by the relative tradeoff parameter  $a$ . The final control can be selected from this set of algorithms with confidence that an effective control and a

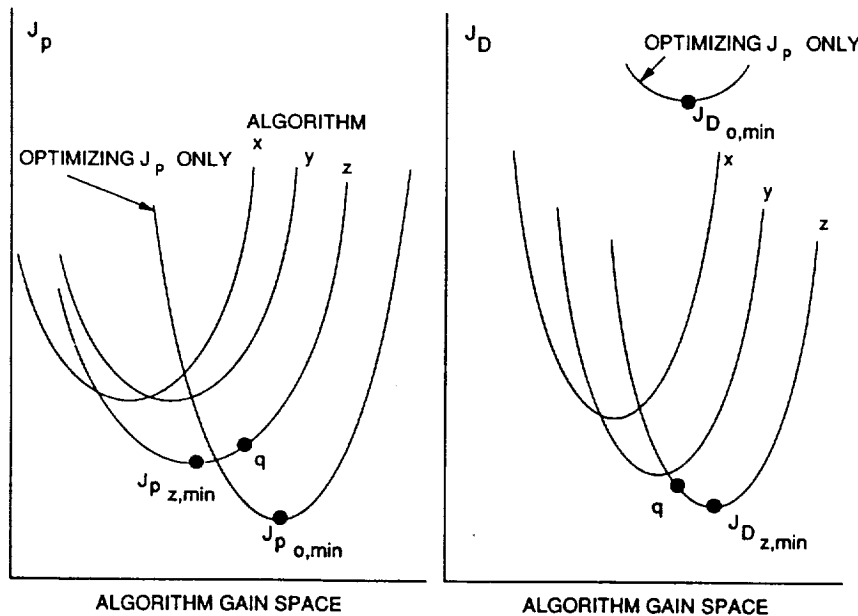

FIGURE 10. Effect of Various Life Extending Control Algorithms on Performance ( $J_p$ ) and Damage ( $J_D$ ).

The final control can be selected from this set of algorithms with confidence that an effective control and a

desirable performance/life tradeoff have been established. It is expected that as LEC technology is developed it will find broad application in high performance aerospace systems and elsewhere.

## EXTENSIONS TO NUCLEAR PROPULSION

While the Nuclear Thermal Rocket engine is conceptually similar to a chemical rocket engine, it is significantly different in several important ways. One potential Nuclear Rocket Engine cycle is shown in Figure 11. Both systems create thrust by heating a working fluid and expanding it through a convergent-divergent nozzle to supersonic velocities. Additionally, turbomachinery provides the necessary supply pressures for the working fluid. The fundamental difference is the heat source in the nuclear rocket results from the reactor core instead of a chemical combustion process. Specific Impulse (defined as  $I_{sp} = \text{Thrust} / \dot{w}_T$ ) for a rocket engine can be expressed as  $I_{sp} = K\sqrt{T}$ . In a chemical rocket the temperature is set by the propellant combination. In a nuclear thermal rocket the temperature is set by the reactor conditions. Thus  $I_{sp}$  is fixed for the chemical rocket but variable for a nuclear thermal rocket limited by core material temperatures.

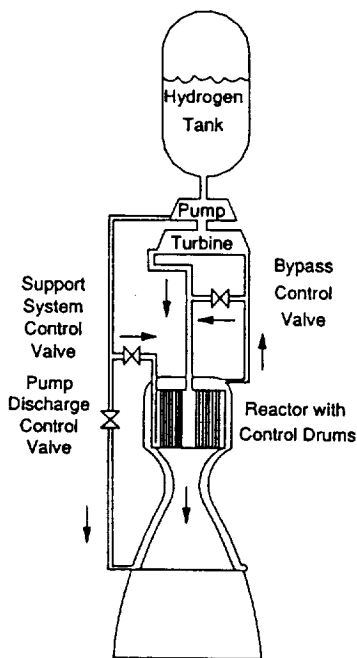

FIGURE 11. Nuclear Thermal Rocket Engine Flow Schematic.

Various studies of nuclear rocket control have been performed (Sanders et al. 1962, Arpasi and Hart 1967, and Hart and Arpasi 1967). The basic control objective of a nuclear rocket is to control thrust level via flow through the turbine and temperature ( $I_{sp}$ ) via core reaction rates (control drums). Temperature control is similar to mixture ratio control in chemical rockets. However, the fundamental dynamics of the heat addition are quite different. An increase of working fluid (Hydrogen for example) into the reactor core thermally reduces core temperature through heat transfer while simultaneously increasing heat generation by increasing the neutron flux (Crouch 1965). Control of this phenomenon will require anticipatory (lead) action by the reactor control system for good transient performance. Many other issues such as startup, shutdown, and idle mode need also be considered.

Many of the technologies being developed and demonstrated for chemical rocket engine control such as Multivariable Control, Intelligent Control and Life Extending Control will be applicable to nuclear rocket engines in the development of durable, reliable and fault tolerant propulsion systems.

## SUMMARY

This paper provided an overview of chemical rocket propulsion control and new technology developments in this area. It is expected that many of these new technologies will find application in the Nuclear Rocket Engine.

## Acknowledgments

The authors wish to gratefully acknowledge the technical input from Carl Aukerman, Dale Arpasi, and Albert Powers.

## References

- Arpasi, D. J. and C. E. Hart (1967) Controls Analysis of Nuclear Rocket Engine at Power Range Operating Conditions, NASA TN D-3978, LeRC, Cleveland, OH., May 1967.
- Cikanek, H. A. (1987) "Characteristics of Space Shuttle Main Engine Failures," in 23th AIAA/SAE/ASME Joint Propulsion Conference, Paper No. 87-1939, San Diego, CA., 29 June - 2 July 1987.
- Crouch, H. F. (1965) *Nuclear Space Propulsion*, Astronuclear Press, Granada Hills, CA., pp. 199-233.
- Hart, C. E., and D. J. Arpasi (1967) Frequency Response and Transfer Functions of a Nuclear Rocket Engine System obtained from Analog Computer Simulation, NASA TN D-3979, LeRC, Cleveland, OH., May 1967.
- Lee, Y. C., M. R. Gore and C. C. Ross (1953) "Stability and Control of Liquid Propellant Rocket Systems," *American Rocket Society Journal*, March-April 1953, pp. 75-81.
- Lorenzo, C. F. and W. C. Merrill (1990) "An Intelligent Control System for Rocket Engines: Needs, Vision and Issues," in Proc. of American Control Conference, San Diego, CA., 23-25 May 1990.
- Lorenzo, C. F. and W. C. Merrill (1991) "Life Extending Control: A Concept Paper," in Proc. of American Control Conference, Boston, MA., 26-28 June 1991.
- Merrill, W. C. and C. F. Lorenzo (1988) "A Reusable Rocket Engine Intelligent Control," in 24th AIAA/SAE/ASME Joint Propulsion Conference, Paper No. 88-3114, Boston, Mass., 11-13 July 1988.
- Musgrave, J. L. (1991) "Linear Quadratic Servo Control of a Reusable Rocket Engine," in 27th AIAA/SAE/ASME Joint Propulsion Conference, Paper No. 91-1999, Sacramento, CA., 24-27 June 1991.
- Nemeth, E. (1990) Reusable Rocket Engine Intelligent Control System Framework Design (Phase I), NASA Contractor Report CR187043 for NASA LeRC by Rocketdyne Div. Rockwell International Corp., Canoga Park, CA., 6 April 1990.
- Nemeth, E., R. Anderson, J. Ols, and M. Olasasky (1991) Reusable Rocket Engine Intelligent Control System Framework Design (Phase II), RI/RD91-158 for NASA LeRC by Rocketdyne Div. Rockwell International Corp., Canoga Park, CA., 21 June 1991.
- Sanders, J. C., H. J. Heppler, and C. E. Hart (1962) Problems in Dynamics and Control of Nuclear Rockets, NASA SP 20, LeRC, Cleveland, OH., December 1962.

# REPORT DOCUMENTATION PAGE

*Form Approved*  
*OMB No. 0704-0188*

Public reporting burden for this collection of information is estimated to average 1 hour per response, including the time for reviewing instructions, searching existing data sources, gathering and maintaining the data needed, and completing and reviewing the collection of information. Send comments regarding this burden estimate or any other aspect of this collection of information, including suggestions for reducing this burden, to Washington Headquarters Services, Directorate for Information Operations and Reports, 1215 Jefferson Davis Highway, Suite 1204, Arlington, VA 22202-4302, and to the Office of Management and Budget, Paperwork Reduction Project (0704-0188), Washington, DC 20503.

<b>1. AGENCY USE ONLY (Leave blank)</b>		<b>2. REPORT DATE</b>	<b>3. REPORT TYPE AND DATES COVERED</b> Technical Memorandum	
<b>4. TITLE AND SUBTITLE</b> Overview of Rocket Engine Control			<b>5. FUNDING NUMBERS</b>  WU-505-62-50	
<b>6. AUTHOR(S)</b> Carl F. Lorenzo and Jeffrey L. Musgrave				
<b>7. PERFORMING ORGANIZATION NAME(S) AND ADDRESS(ES)</b> National Aeronautics and Space Administration Lewis Research Center Cleveland, Ohio 44135-3191			<b>8. PERFORMING ORGANIZATION REPORT NUMBER</b>  E-6673	
<b>9. SPONSORING/MONITORING AGENCY NAMES(S) AND ADDRESS(ES)</b> National Aeronautics and Space Administration Washington, D.C. 20546-0001			<b>10. SPONSORING/MONITORING AGENCY REPORT NUMBER</b>  NASA TM-105318	
<b>11. SUPPLEMENTARY NOTES</b> Prepared for the Ninth Symposium on Space Nuclear Power Systems sponsored by the University of New Mexico, Albuquerque, New Mexico, January 12-16, 1992. Responsible person, Carl F. Lorenzo, (216) 433-3733.				
<b>12a. DISTRIBUTION/AVAILABILITY STATEMENT</b>  Unclassified - Unlimited Subject Category 20			<b>12b. DISTRIBUTION CODE</b>	
<b>13. ABSTRACT (Maximum 200 words)</b>  This paper broadly covers the issues of Chemical Rocket Engine Control. The basic feedback information and control variables used in expendable and reusable rocket engines, such as the Space Shuttle Main Engine are discussed. The deficiencies of current approaches are considered and a brief introduction to Intelligent Control Systems for rocket engines (and vehicles) is presented.				
<b>14. SUBJECT TERMS</b> Rocket engine control; Nuclear rocket engines; Nuclear propulsion			<b>15. NUMBER OF PAGES</b> 12	
			<b>16. PRICE CODE</b> A03	
<b>17. SECURITY CLASSIFICATION OF REPORT</b> Unclassified	<b>18. SECURITY CLASSIFICATION OF THIS PAGE</b> Unclassified	<b>19. SECURITY CLASSIFICATION OF ABSTRACT</b> Unclassified	<b>20. LIMITATION OF ABSTRACT</b>	

