

Aircraft Ground Test and Subscale Model Results of Axial Thrust Loss Caused by Thrust Vectoring Using Turning Vanes

Steven A. Johnson

JANUARY 1992

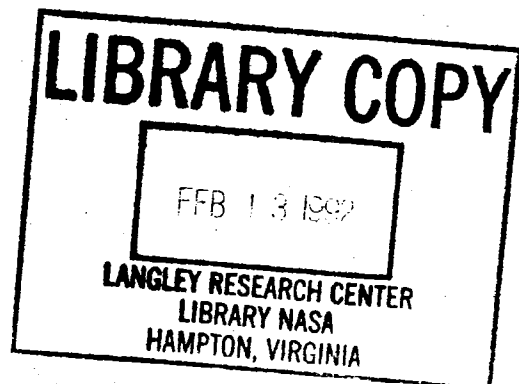

FOR REFERENCE

NOT TO BE TAKEN FROM THIS ROOM

NASA

NASA Technical Memorandum 4341

Aircraft Ground Test and Subscale
Model Results of Axial Thrust
Loss Caused by Thrust Vectoring
Using Turning Vanes

Steven A. Johnson
Dryden Flight Research Facility
Edwards, California



National Aeronautics and
Space Administration

Office of Management

Scientific and Technical
Information Program

1992

CONTENTS

ABSTRACT	1
INTRODUCTION	1
NOMENCLATURE	2
EQUIPMENT AND PROCEDURES	2
Airplane Description	2
Thrust Stand Test	6
Thrust Stand Procedure	7
Cold-Jet Model Description	8
Cold-Jet Procedure	10
RESULTS AND DISCUSSION	10
Cold-Jet Test Results	10
Full-Scale Aircraft Results	14
Comparison of Single- and Dual-Vane Results	15
Comparison of F/A-18 High Alpha Research Vehicle and Subscale Model Results	16
Single-Vane 3 Deflections	16
Dual-Symmetric-Vane 2 and 3 Deflections	19
CONCLUDING REMARKS	21
REFERENCES	22

FIGURES

1	The F/A-18 high alpha research vehicle with the thrust vectoring control system installed.	3
2	The F/A-18 high alpha research vehicle thrust vectoring system.	4
3	Schematic of jet turning angle and axial thrust loss.	5
4	The F/A-18 high alpha research vehicle during single-engine thrust vectoring testing with maximum afterburner, vane 1 = -10° , and vanes 2 and 3 = 20°	6
5	Typical time history of commanded vane deflections and the corresponding effect on axial thrust for the F/A-18 high alpha research vehicle ground test.	8
6	Effect of engine thrust on true vane deflection at 15, 20, and 25° commanded deflection.	9
7	Vane attachment for the 14.25 percent scale model used in the NASA Langley cold-jet test setup.	11
8	Comparison of axial thrust loss resulting from geometric turning of the thrust vector with losses from vane flow divergence, pressure, and friction effects using NASA Langley subscale model results.	12
9	Effects of nozzle pressure ratio on axial gross thrust loss as a function of dual-vane deflection angle using NASA Langley subscale model.	13
10	Effects of nozzle throat area on axial gross thrust loss as a function of dual-vane deflection angle using NASA Langley subscale model.	13
11	Effects of nozzle pressure ratio on axial gross thrust loss as a function of dual-vane deflection angle for the F/A-18 high alpha research vehicle thrust vectoring test.	14
12	Effects of nozzle throat area on axial gross thrust loss as a function of dual-vane deflection angle for the F/A-18 high alpha research vehicle thrust vectoring test.	15
13	Effects of single- and dual-vane deflection on axial gross thrust loss for F/A-18 high alpha research vehicle thrust vectoring for engine condition 2.	16
14	Comparison of the NASA Langley subscale model and the F/A-18 high alpha research vehicle thrust loss as a function of single-vane deflection angle for engine condition 1.	17
15	Comparison of the NASA Langley subscale model and the F/A-18 high alpha research vehicle thrust loss as a function of single-vane deflection angle for engine condition 2.	17
16	Comparison of the NASA Langley subscale model and the F/A-18 high alpha research vehicle thrust loss as a function of single-vane deflection angle for engine condition 3.	18

17	Comparison of the NASA Langley subscale model and the F/A-18 high alpha re- search vehicle thrust loss as a function of dual-vane deflection angle for engine condition 1.	19
18	Comparison of the NASA Langley subscale model and the F/A-18 high alpha re- search vehicle thrust loss as a function of dual-vane deflection angle for engine condition 2.	20
19	Comparison of the NASA Langley subscale model and the F/A-18 high alpha re- search vehicle thrust loss as a function of dual-vane deflection angle for engine condition 3.	20

TABLES

1	Throttle setting configurations for the full-scale F/A-18 high alpha research vehicle F404-GE-404 engine tests.	7
2	Single-vane 3 F/A-18 high alpha research vehicle and NASA Langley cold-jet axial thrust loss comparisons for selected vane-deflection angles.	18
3	Dual-vane 2 and 3 F/A-18 high alpha research vehicle and NASA Langley cold-jet axial thrust loss comparisons for selected vane-deflection angles.	21

ABSTRACT

The NASA Dryden Flight Research Center F/A-18 high alpha research vehicle was modified to incorporate three independently controlled turning vanes located aft of the primary nozzle of each engine to vector thrust for pitch and yaw control. Ground-measured axial thrust losses were compared with the results from a 14.25 percent cold-jet model for single- and dual-vanes inserted up to 25° into the engine exhaust. Data are presented for nozzle pressure ratios of 2.0 and 3.0 and nozzle exit areas of 253 and 348 in². The findings of this study indicate that subscale static nozzle test results properly predict trends but underpredict the full-scale results by approximately 1 to 4.5 percent in thrust loss.

INTRODUCTION

Interest in high-agility aircraft has led to many experiments designed to incorporate thrust vectoring into current and next generation aircraft (refs. 1–5). Using multiaxis thrust vectoring to direct the thrust force vector away from the usual axial direction has the potential for providing substantial airplane performance gains (ref. 6). Most past studies have been performed with subscale static (no external flow) nozzles using room temperature and high-pressure air to simulate the jet-exhaust flow. Little full-scale thrust vectoring data exists to use as criteria for evaluating the validity of the static nozzle testing results.

Two aircraft with multiaxis thrust vectoring capability are rapidly approaching flight status. Both the Navy X-31A aircraft (ref. 7) and the NASA F/A-18 high alpha research vehicle thrust vectoring control system (ref. 8) employ axisymmetric nozzles with postexit turning vanes. Simple, externally mounted, postexit turning vanes allow a thrust vectoring installation with a minimum amount of engine and aircraft modification; however, turning-vane configurations incur large axial thrust losses to achieve vectored thrust (ref. 9). These losses result from the turning of the gross thrust vector, the pressure and friction drags associated with the thrust vectoring hardware, and the divergence of the exhaust flow.

Early design data were required during development of the axisymmetric nozzle with turning vanes for the NASA F/A-18 high alpha research vehicle thrust vectoring control system. A 14.25 percent static nozzle test was performed at the NASA Langley Research Center 16-ft Transonic Tunnel Cold-Jet Facility to evaluate the thrust vectoring effectiveness of the turning vanes. Axial thrust loss caused by vane deflection was also investigated during the test. These data were incorporated into the F/A-18 high alpha research vehicle dynamic aircraft simulation for thrust vectoring control system development and performance modeling (ref. 10).

The NASA Dryden Flight Research Facility conducted a thrust vectoring ground test using the F/A-18 high alpha research vehicle as part of a flight qualification ground test. During the test, axial thrust loss was measured on the Air Force Flight Test Center horizontal test stand. This data were used to investigate the effect of different scales, exhaust gas temperatures, and velocities that exist between the aircraft and the subscale model tests. In addition, the data were used to validate the F/A-18 high alpha research vehicle thrust vectoring performance models.

This paper describes the full-scale results of axial thrust loss caused by thrust vectoring with turning vanes for vane-deflection angles of up to 25°, nozzle pressure ratios of 2.0 and 3.0, and nozzle throat

areas of 253 and 348 in². The results were compared with similar test conditions obtained from the NASA Langley Research Center subscale static nozzle test results. The effects of single- and dual-vane-deflection angle, nozzle pressure ratio, and nozzle exit area on axial thrust loss are also presented.

NOMENCLATURE

AB	afterburner
A8	nozzle throat area, in ²
GE	General Electric, Lynn, Massachusetts
HARV	high alpha research vehicle
mil power	military power
NPR	nozzle pressure ratio
PLA	power lever angle, deg
TVCS	thrust vectoring control system
vane 1	upper vane
vane 2	outboard vane
vane 3	inboard vane

EQUIPMENT AND PROCEDURES

Airplane Description

The high alpha research vehicle (HARV) is a preproduction, single-seat, F/A-18 aircraft previously used for high-angle-of-attack and spin testing (fig. 1). A thrust vectoring system and extensive instrumentation were added to the HARV for high-angle-of-attack flight research and thrust vectoring control evaluation (ref. 8). The aircraft thrust vectoring flight test envelope is Mach 0.2 to 0.7 and altitude of 15,000 to 35,000 ft.

The F/A-18 HARV aircraft is powered by two F404-GE-400 engines (General Electric, Lynn, Massachusetts). This engine is a 16,000 lbf thrust class, low bypass, twin-spool turbofan with afterburner (AB). The engine incorporates a three-stage fan and a seven-stage, high-pressure compressor. Each engine is driven by a single-stage turbine (ref. 11). During flight, power lever angle (PLA) ranges from 31° at flight idle to 130° at full power with AB. Full nonafterburning military (mil) power occurs at 87° PLA. With installation of the thrust vectoring control system (TVCS), the divergent portion of the nozzle and the external nozzle flaps are removed from the engines. The convergent part of the nozzle remains on the engine. The convergent nozzle exit area in the mil power setting is typically 220 in², and the maximum AB nozzle area is typically 348 in² for the thrust vectoring envelope of the aircraft. The nozzle area for sea level static operation is typically 220 in² for mil power and 410 in² in maximum AB.



EC 910010-006

Figure 1. The F/A-18 high alpha research vehicle with the thrust vectoring control system installed.

The TVCS modification included adding six thrust vectoring vanes. Three vanes were located about the centerline of each engine (fig. 2). These double-curvature vanes are limited to a deflection range of from -10° out of the jet exhaust to 25° into the jet exhaust. The location and geometry of the turning vanes were a result of design tradeoffs between thrust vectoring performance and possible interference with aerodynamic surfaces or the vanes themselves. The final TVCS design does not represent a production prototype but is strictly an experimental installation.

The F/A-18 HARV vane configuration can generate both pitch and yaw forces. Root mean square of the pitch force and the yaw force is defined as the resultant vectoring force. The overall jet turning angle is defined as the angle between the resultant vectoring force and the axial thrust. Figure 3 shows a geometric vector representation of the overall jet turning angle. Axial thrust loss for the vectored exhaust is defined as the loss of thrust in the axial direction when compared to the undeflected thrust. The remaining axial gross thrust, expressed in percent, is the ratio of the axial force and the undeflected thrust multiplied by 100.

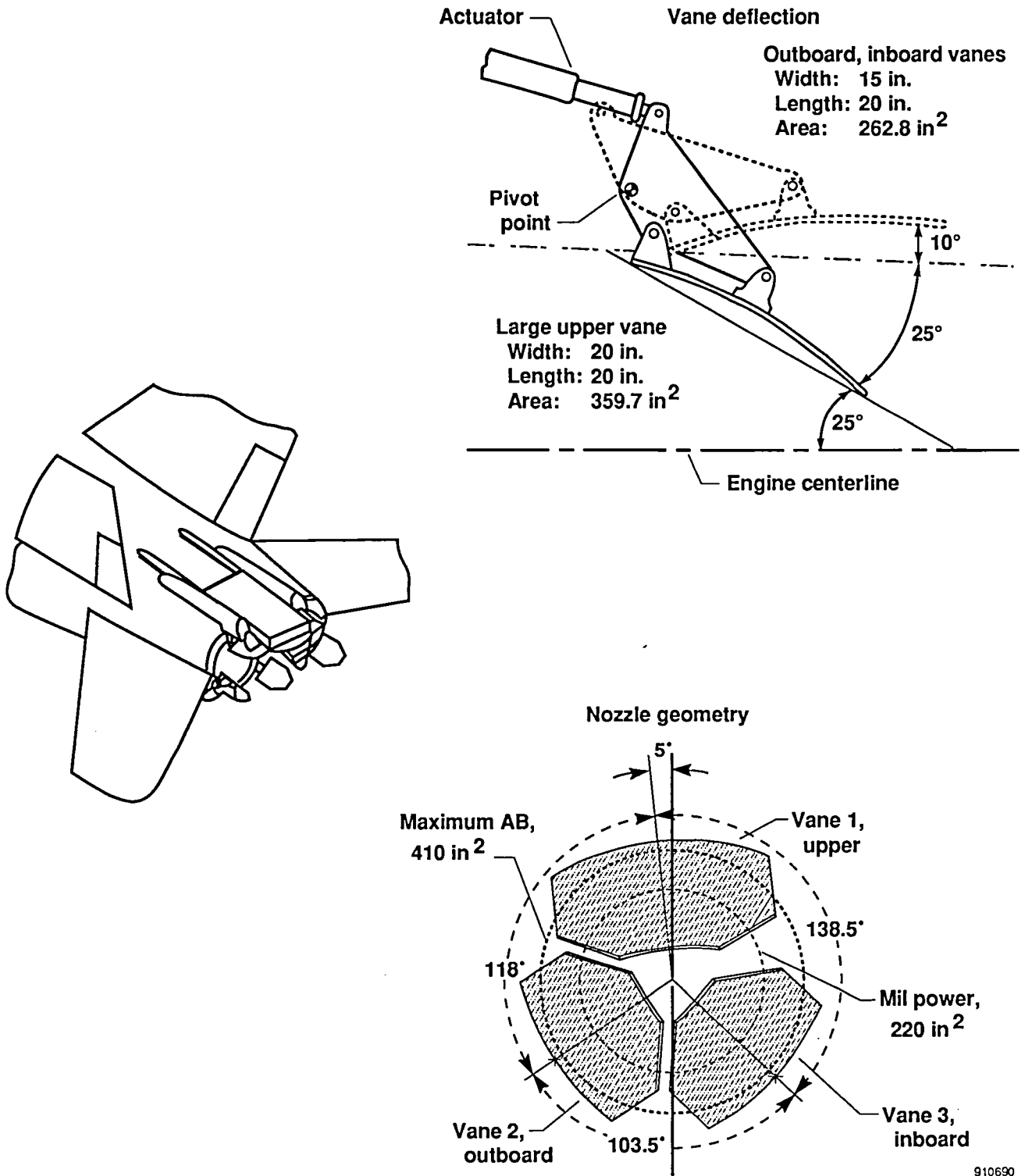

910690

Figure 2. The F/A-18 high alpha research vehicle thrust vectoring system.

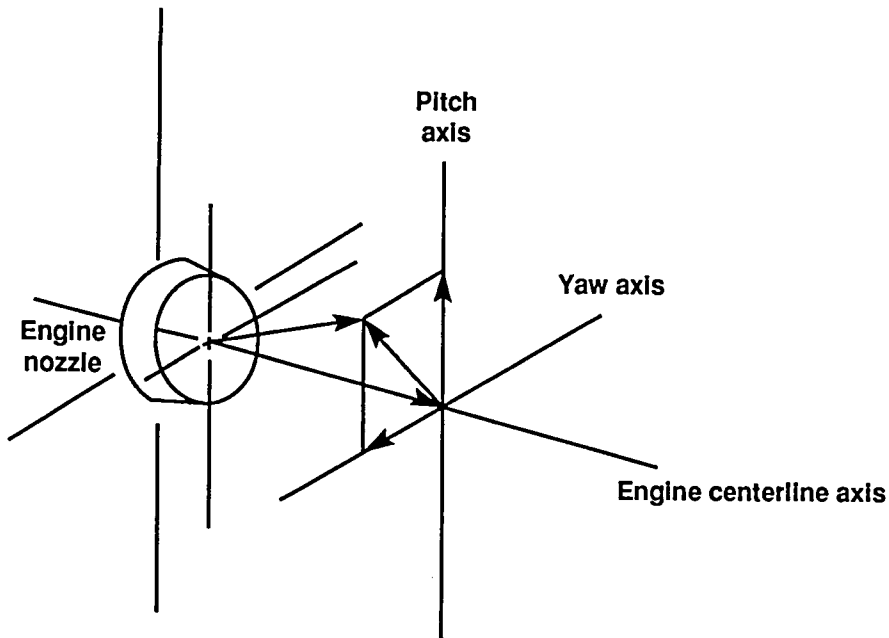
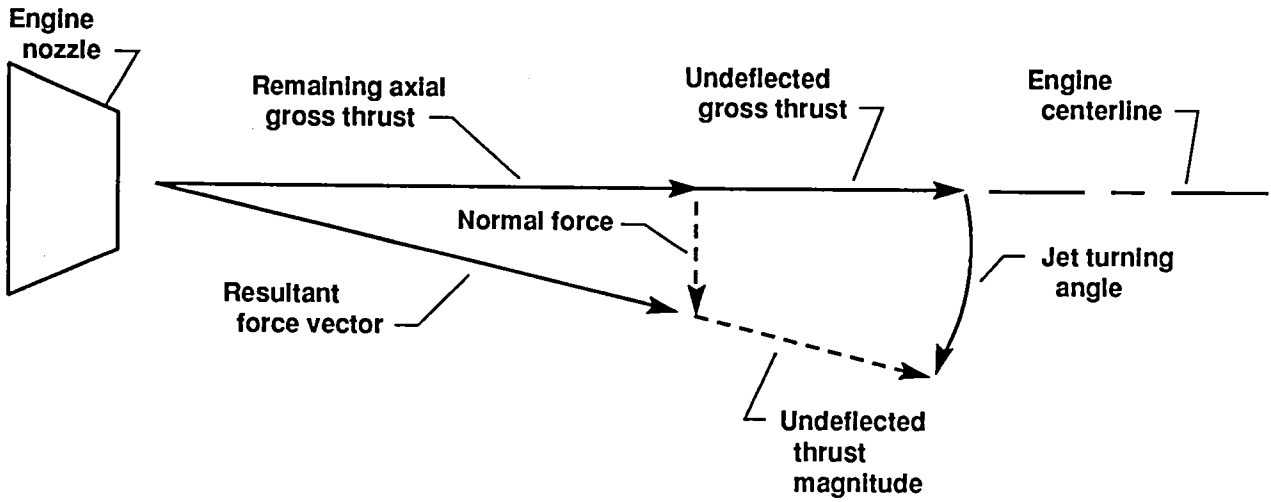

910691

Figure 3. Schematic of jet turning angle and axial thrust loss.

Thrust Stand Test

As part of the functional evaluation of the thrust vectoring system, a ground test was performed using the F/A-18 HARV with the engines and thrust vectoring system operating. The portion of the test described in this technical memorandum had the left engine and left vane set in use.

Axial thrust loss caused by thrust vectoring exhaust gas of the F/A-18 HARV was measured on the Air Force Fight Test Center horizontal test stand. The parameters recorded for this full-scale static ground test included a load cell to measure the axial thrust, the engine pressures, the engine temperatures, and the throttle and nozzle position. Engine data were acquired at 40 samples/sec. The test stand axial load measurement data were recorded at a rate of 1 sample/sec. The load measurement has an accuracy of approximately 0.7 percent over the range of thrust values acquired during this test. In addition, test day ambient pressures, temperatures, and winds were recorded.

The F/A-18 HARV was tied to the test stand using specially designed equipment. This equipment was composed of locking wheel chocks as well as fore and aft tie-down chains attached to the test stand axial load measurement table. With this tie-down arrangement, minimum aircraft movement occurred during thrust vectoring, and all axial forces generated by the aircraft were imparted to the thrust measuring table. Vertical and lateral forces needed to measure pitch and yaw vectoring were unavailable. Figure 4 shows the F/A-18 HARV and the tie-down equipment during testing at maximum AB. In addition, the photograph shows the inboard and outboard vanes of the left engine deflected to 20° into the jet exhaust and the upper vane at -10° out of the jet exhaust.



EC91 0075-038

Figure 4. The F/A-18 high alpha research vehicle during single-engine thrust vectoring testing with maximum afterburner, vane 1 = -10° , and vanes 2 and 3 = 20° .

Axial thrust loss caused by thrust vectoring with turning vanes was measured at three throttle settings during the test. Table 1 summarizes the key engine parameters for each throttle setting. The throttle settings were chosen to most closely match the test conditions performed in the NASA Langley Research Center (NASA Langley) cold-jet test. At the test day conditions, the throttle could be varied to achieve a nozzle pressure ratio (NPR) of 2.0 to 3.0, and the nozzle throat area (A8) could vary from 220 to 410 in². The NPR and A8 were impossible to vary independently by adjusting the throttle on the F404-GE-400 engine because the two engine parameters are coupled (ref. 11).

Table 1. Throttle setting configurations for the full-scale F/A-18 high alpha research vehicle F404-GE-404 engine tests.

F-404 engine condition			
Engine condition	Throttle, deg	NPR	A8, in ²
1	submilitary power, 61	2.1	253
2	military power, 87	3.0	258
3	midafterburning, 110	2.9	348

Thrust Stand Procedure

Data were gathered for more than 50 configurations during this series of full-scale F/A-18 HARV thrust vectoring tests. This test data included two principle A8 configurations, two NPR's, and a variety of vane-deflection configurations. The procedure for each test condition was to first establish the proper throttle position. After the engines were allowed to stabilize for a minimum of 30 sec, the test vanes were inserted into the exhaust flow in 5° increments. Typically, the test vanes were held at a constant insertion angle for 10 sec. The vanes were then retracted to the -10° position to cool for 15 sec before being reinserted to the next higher angular increment. A typical time history of axial thrust and commanded vane deflection as a function of time is shown in figure 5. Engine data and test stand thrust measurements were averaged over the 10 sec vane-deflection time. The F/A-18 HARV thrust 1 sec before a vane insertion event was compared with the time averaged axial thrust during the vane insertion. This method minimized the effects of any test conditions where the engine had not reached full-thrust stabilization at the start of the test.

For vane angles greater than 10°, the true vane-deflection angle was less than the commanded vane-deflection angle because of structural deformation. Corrections were applied to the commanded vane-deflection angle according to deflection data obtained during a laboratory structural proof test. The corrections applied are presented in figure 6. The NASA Langley cold-jet vane attachment was assumed to be rigid for all practical purposes.

The instrumentation required for a direct measurement of NPR was not available for this test. As a result, NPR was calculated by using the manufacturer's computer simulation of the F404-GE-400 engine. The computer model is a full aerothermal, steady-state, performance program. This model was derived from test data and represents the operation of an average F404-GE-400 engine. The simulation provides the values for a number of internal flow parameters including nozzle discharge total pressure. Engine pressures and temperatures from the ground test were used to match identical internal flow parameters

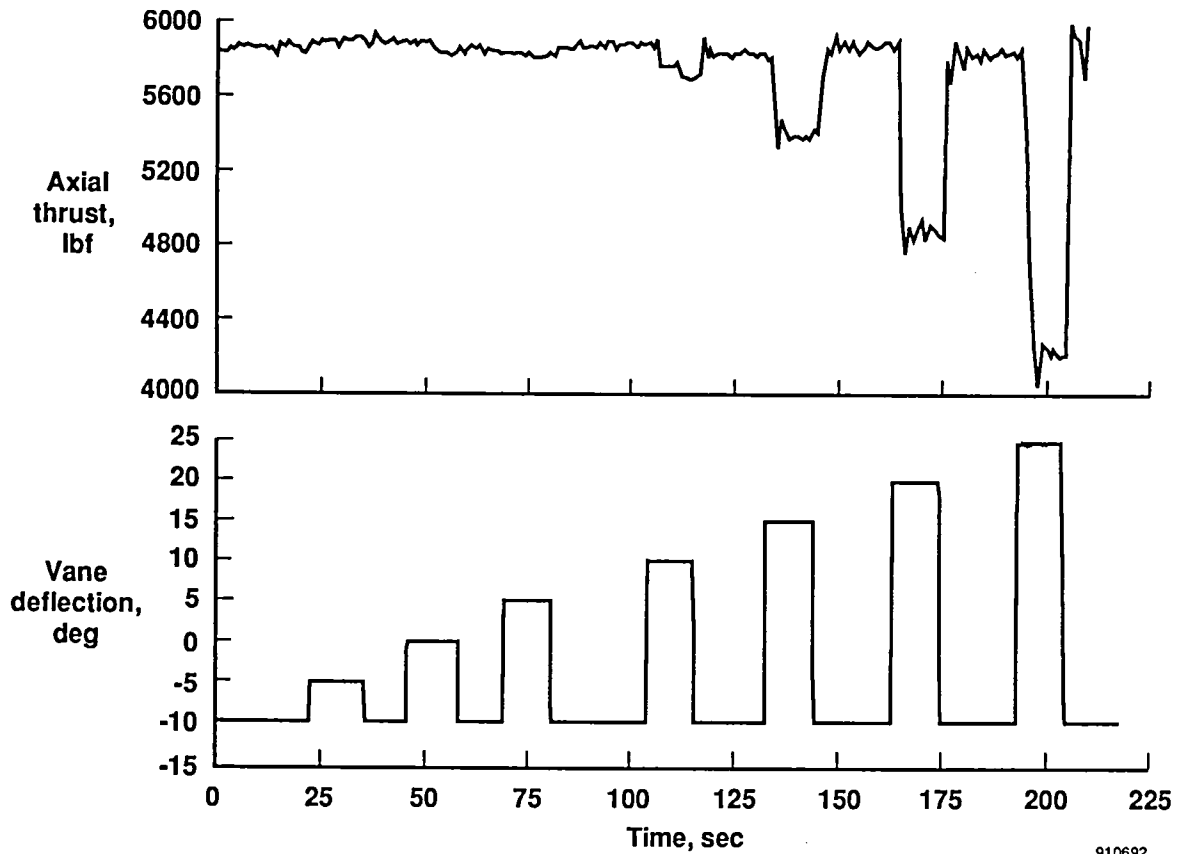

910692

Figure 5. Typical time history of commanded vane deflections and the corresponding effect on axial thrust for the F/A-18 high alpha research vehicle ground test.

of the computer simulation thus adding to the accuracy of the simulation output. The computed nozzle discharge total pressure was divided by test day ambient pressure to calculate NPR.

The full-scale engine NPR, A8 test conditions, and true vane-deflection angles did not perfectly match the NASA Langley test conditions. For example, from table 1, engine condition 1 had an NPR of 2.1 and an A8 of 253 in². The closest NASA Langley test conditions were an NPR of 2.0 and an A8 of 220 in². To compare the NASA Langley data to the full-scale aircraft test data, the NASA Langley data were linearly interpolated with respect to engine test condition and the true aircraft vane-deflection angle.

Cold-Jet Model Description

Early information on the thrust vectoring capability of the F/A-18 HARV vane configuration was required for performance modeling and control law development. To obtain this early information, a 14.25 percent scale model was tested in the NASA Langley 16-ft Transonic Tunnel Cold-Jet Facility. The cold-jet standard instrumentation included a force and moment balance and several pressure transducers. The total and static pressures were used to determine the NPR.

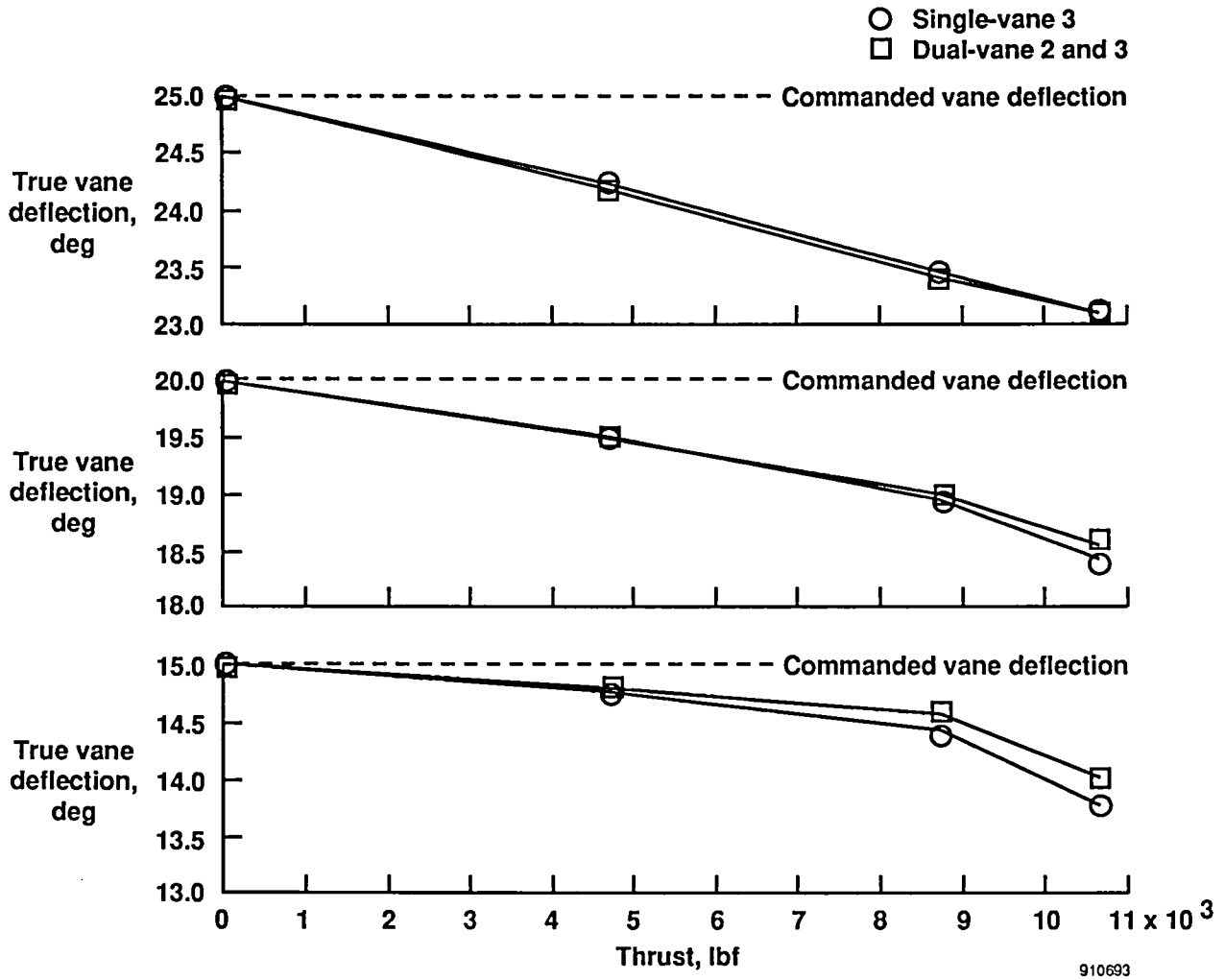

Figure 6. Effect of engine thrust on true vane deflection at 15, 20, and 25° commanded deflection.

Figure 7 illustrates the single nozzle and the attachment for the top vane; the inboard and outboard vanes have similar attachments. The single nozzle was a model of the left engine nozzle. The external flow around the model nozzle was not tested, so no attempt was made to model the external geometry of the nozzle. The size of the axisymmetric nozzles used in the cold-jet test corresponds to the typical flight mil power and maximum afterburning power nozzle sizes, 220 in² and 348 in², respectively. The vanes in this test accurately reproduced the shape and geometry of the flight hardware at 14.25 percent of full-scale. The vanes were individually positioned manually using protractors. As a result, the accuracy of any particular vane-deflection angle setting was within $\pm 1/2^\circ$.

Cold-Jet Procedure

The detailed procedure involved in running the NASA Langley 16-ft Transonic Tunnel Cold-Jet Test Facility has been presented by other authors (ref. 9). The unique aspects of the thrust vectoring concept with turning vanes and its effect on the procedure will be discussed briefly. Measurements obtained from the force and moment balance were used to calculate the exhaust plume deflection angles and axial thrust loss. The NPR values were selected on the basis of expected flight NPR values with the F/A-18 HARV TVCS. Data for NPR values of 2, 3, 4, 5, and 6 were obtained at each vane setting. The NPR values were repeatable to within 0.007 tolerance with the test instrumentation.

Two nozzles were used during the investigation. One nozzle had a 4.467-in² throat area or a 220-in² full-scale equivalent, and the other had a 7.067-in² throat area or a 348-in² full-scale equivalent. The vanes were set at deflection angles ranging from 10° out of the exhaust flow to 30° into the exhaust flow. Generally, the vane deflections were incremented in 5° steps between test conditions. More than 300 configurations were cold-jet tested. For example, two A8, five NPR, and varied vane configurations were tested. These configurations also included vanes off, one vane deflected, two vanes deflected, three vanes deflected, and no vanes deflected setups.

RESULTS AND DISCUSSION

Axial thrust loss comparisons are presented for single-engine operation for two different vane-deflection combinations at various NPR's and A8's. The first vane combination studied was symmetric-vane 2 and 3 deflections with vane 1 fixed in the stowed, -10° position. The second vane combination studied was single-vane 3 deflections with vanes 1 and 2 fixed at the stowed, -10° position. During the full-scale aircraft test, other single- and dual-vane deflections showed the same trends as those observed with the single-vane 3 and symmetric-vane 2 and 3 deflections. As a result, only the single-vane 3 and symmetric-vane 2 and 3 data are presented.

Cold-Jet Test Results

Axial thrust loss because of thrust vectoring with turning vanes is caused by the turning of the gross thrust vector, the pressure and friction drags associated with the thrust vectoring hardware, and the exhaust flow divergence. Thrust vectoring performance results from the NASA Langley cold-jet test were used to illustrate the contribution of the geometric turning of the gross thrust vector to the total axial gross thrust loss. Figure 8 shows results of the NASA Langley subscale model and compares the axial thrust losses caused by the jet turning angle with the total axial gross thrust loss as a function of

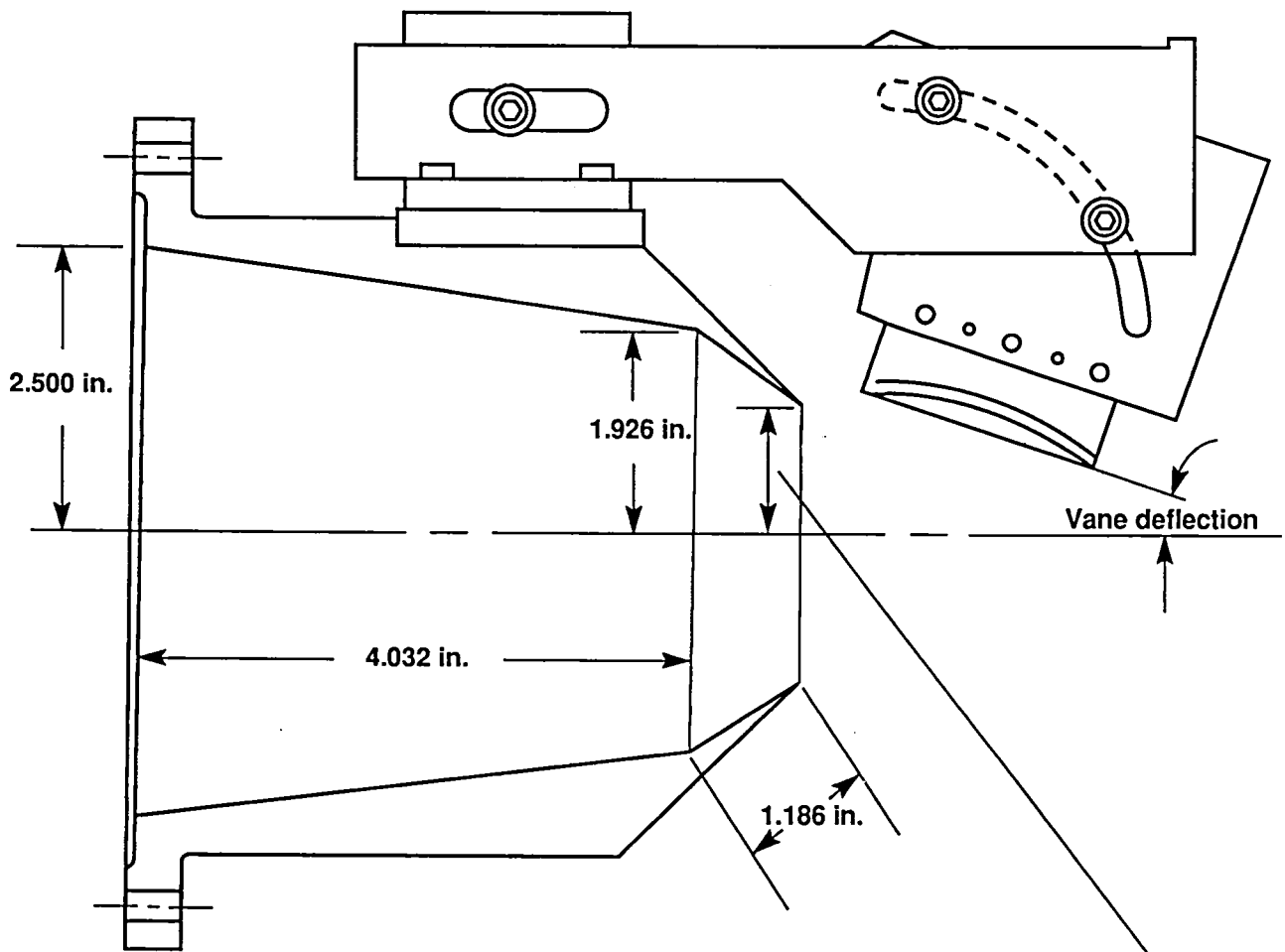

	Nozzle radius, in.	Nozzle area, in ²
Mil power	1.192	4.467
Maximum afterburner	1.500	7.067

910694

Figure 7. Vane attachment for the 14.25 percent scale model used in the NASA Langley cold-jet test setup.

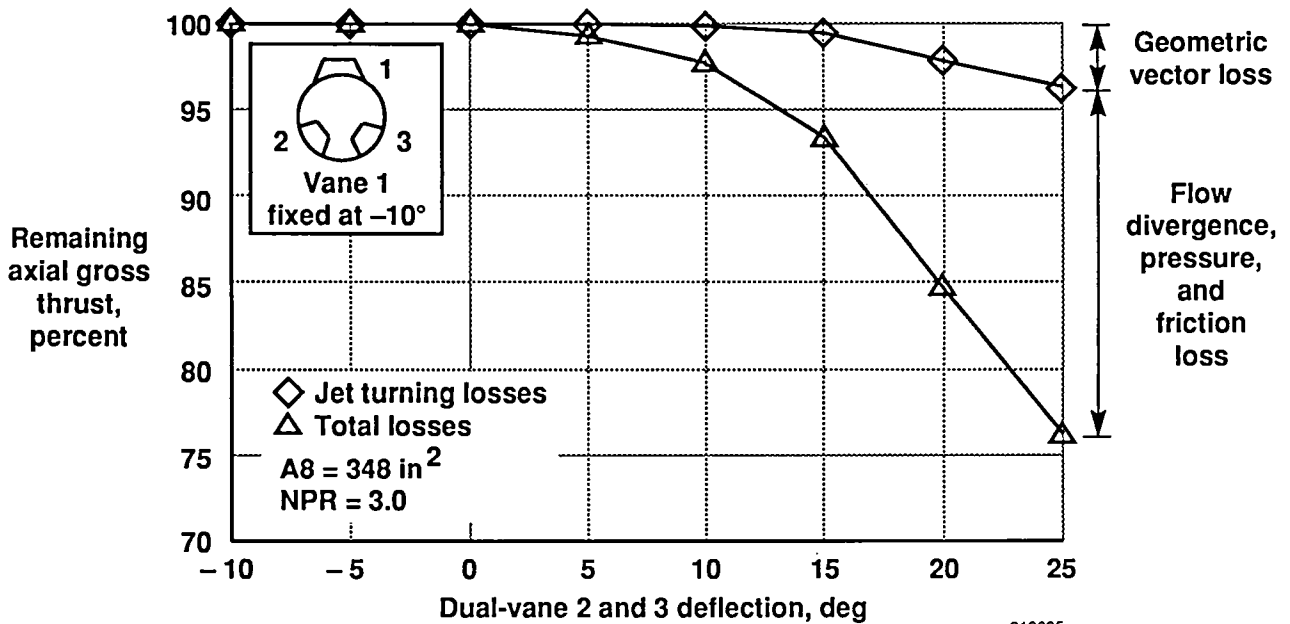

910695

Figure 8. Comparison of axial thrust loss resulting from geometric turning of the thrust vector with losses from vane flow divergence, pressure, and friction effects using NASA Langley subscale model results.

dual-vane deflection. Axial thrust loss caused by the jet turning angle was a small component of the total thrust loss. At a dual-vane 2 and 3 deflection of 25° , the geometric turning of the gross thrust vector resulted in a 4 percent axial thrust loss as compared to the total axial thrust loss of 24 percent.

To gain some insight into the predicted effect NPR and A8 have on axial thrust loss caused by vane deflection, the basic cold-jet data were plotted for symmetric-vane 2 and 3 deflection at two NPR's and A8's. Figure 9 shows axial thrust loss in terms of percent of remaining axial thrust for NPR's of 2.0 and 3.0 with the A8 held constant at 220 in^2 . The NPR = 3.0 results differed from NPR = 2.0 results by less than 1 percent between vane deflections of 0 to 15° . When the vanes were further deflected, the difference increased slightly. At 25° , an NPR = 3.0 resulted in an axial thrust loss of 27.9 percent. This thrust loss was 2.6 percent more than the NPR = 2.0 results. This slight increase was attributed to the larger plume size with greater NPR. The increased plume size caused more flow to interact with the turning vanes, greater geometric turning of the thrust vector, and larger thrust losses because of friction drag and flow divergence around the vanes.

Figure 10 shows axial thrust loss in terms of percent remaining axial thrust for A8's of 220 and 348 in^2 with the NPR held constant at 3.0. The $A8 = 348\text{-in}^2$ results showed more axial thrust loss than the $A8 = 220\text{-in}^2$ results between vane deflections of 0 to 20° . This increase in thrust loss resulted from more flow interacting with the turning vanes because of the larger plume size with increased A8. At vane 2 and 3 deflections of 25° , this trend reversed. At this configuration, the mil power nozzle resulted in 4 percent more axial thrust loss than the maximum AB nozzle. In part, such reversals resulted from greater geometric turning of the thrust vector with the mil power nozzle. With a large nozzle throat area, the stowed vane (that is, vane 1 at -10°) reduced the turning of the thrust vector at large vane-deflection angles (ref. 10). Such reductions resulted in less axial thrust loss caused by the jet turning angle.

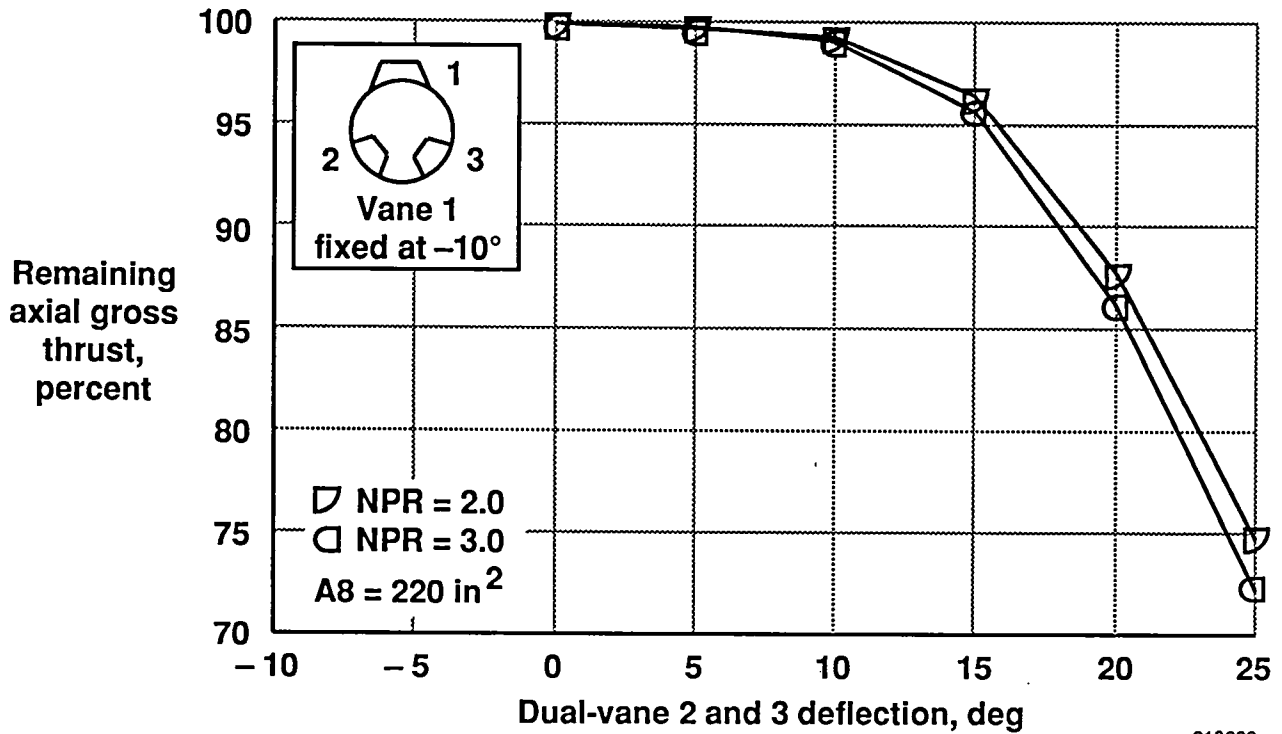

910696

Figure 9. Effects of nozzle pressure ratio on axial gross thrust loss as a function of dual-vane deflection angle using NASA Langley subscale model.

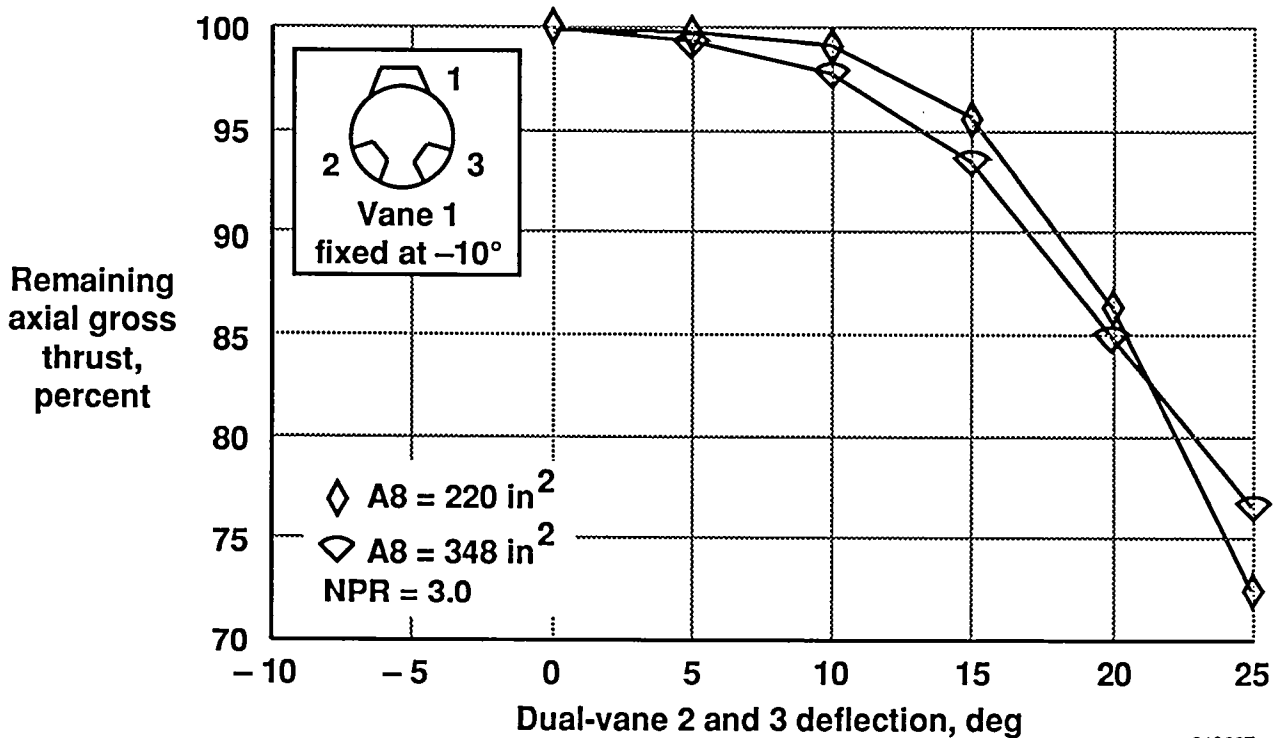

910697

Figure 10. Effects of nozzle throat area on axial gross thrust loss as a function of dual-vane deflection angle using NASA Langley subscale model.

Full-Scale Aircraft Results

Data are presented from the full-scale F/A-18 HARV test at similar vane deflection, NPR, and A8 conditions as those measured in the NASA Langley cold-jet test. There were, however, some notable differences between the full-scale F/A-18 HARV and NASA Langley cold-jet tests. One difference was in scale effects. The static nozzle and vane systems were 14.25 percent scale of the F/A-18 HARV hardware. Another difference was in exhaust temperature. In this case, the NASA Langley 16-ft Transonic Tunnel Cold-Jet Facility employed a high-pressure air system which provided a continuous flow of clean, dry air at a controlled temperature of approximately 540 °R. The F404-GE-400 engine exhaust temperature varies with throttle position. The nozzle exit temperatures were approximately 1300, 1670, and 2470 °R for throttle settings of 61, 87, and 110°, respectively. Finally, the exit velocity of the gas at the nozzle throat exit differs. The NASA Langley cold-jet test had a constant gas exit velocity of 1040 ft/sec. On the other hand, F404-GE-400 engine exhaust velocity varies with gas temperature. The exit velocities were approximately 1590, 1800, and 2175 ft/sec for 61, 87, and 110° throttle settings, respectively. The temperatures and velocities were estimated using the manufacturer's computer simulation of the F404-GE-400 engine.

The effects NPR and A8 had on axial thrust loss caused by symmetric-vane 2 and 3 deflection for the F/A-18 HARV thrust vectoring test are shown in figures 11 and 12. Figure 11 shows axial thrust loss in terms of percent of remaining axial thrust for NPR's of 2.1 and 3.0 with A8 held relatively constant at 253 and 258 in², respectively. The NPR = 3.0 results differed from the NPR = 2.1 results by less than 1 percent across the commanded vane-deflection range from 0 to 25°. The thrust loss was

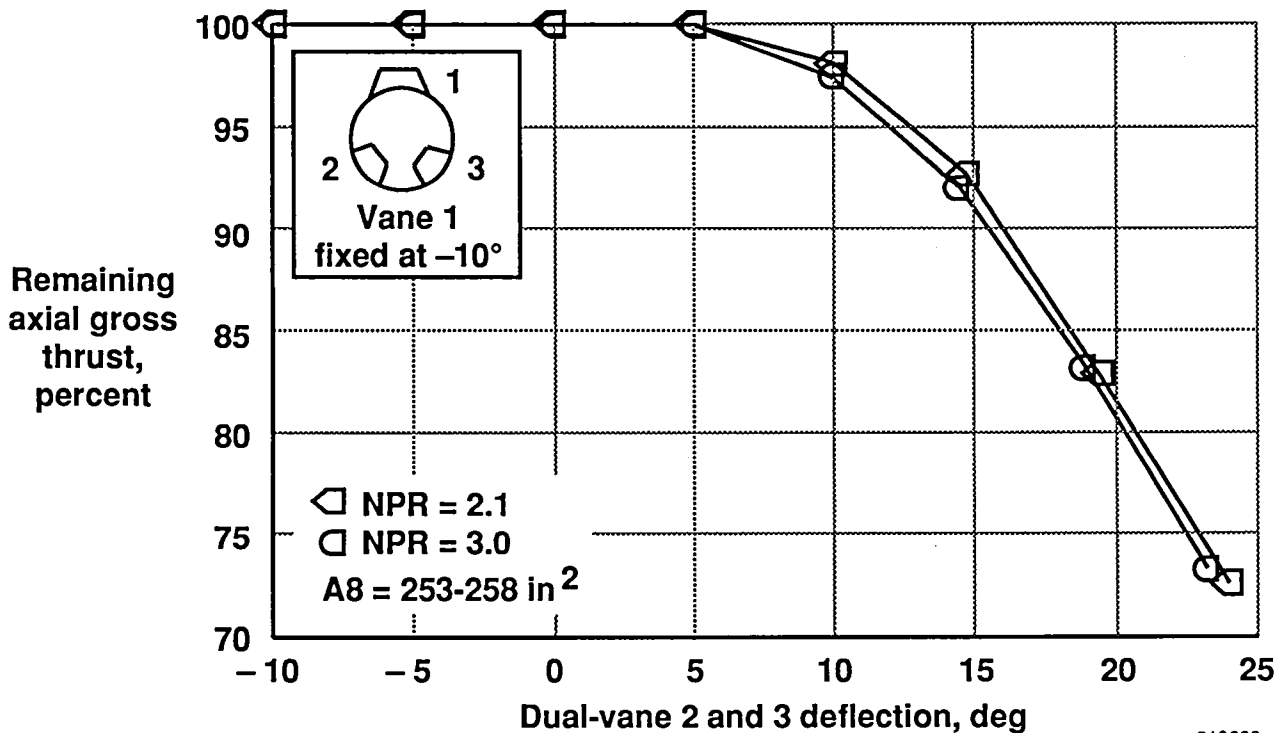

910698

Figure 11. Effects of nozzle pressure ratio on axial gross thrust loss as a function of dual-vane deflection angle for the F/A-18 high alpha research vehicle thrust vectoring test.

slightly greater for an NPR of 3.0 than for an NPR of 2.1. This trend is consistent with the NASA Langley cold-jet test results presented in figure 9.

Figure 12 shows axial thrust loss in terms of percent of remaining axial thrust for A8's of 258 and 348 in² with the NPR held relatively constant at 3.0 and 2.9, respectively. The A8 = 348 in² results showed more axial thrust loss than the A8 = 258 in² results between commanded vane deflections of 0 to 20°. This increase in thrust loss was probably a result of more flow interacting with the turning vanes because of the larger plume size with increased A8. At commanded dual-vane deflections of 25°, that is, 23° true vane deflection, this trend reversed. At this configuration, the mil power nozzle resulted in 4 percent more axial thrust loss than the maximum AB nozzle. This trend is consistent with the NASA Langley cold-jet test results presented in figure 10.

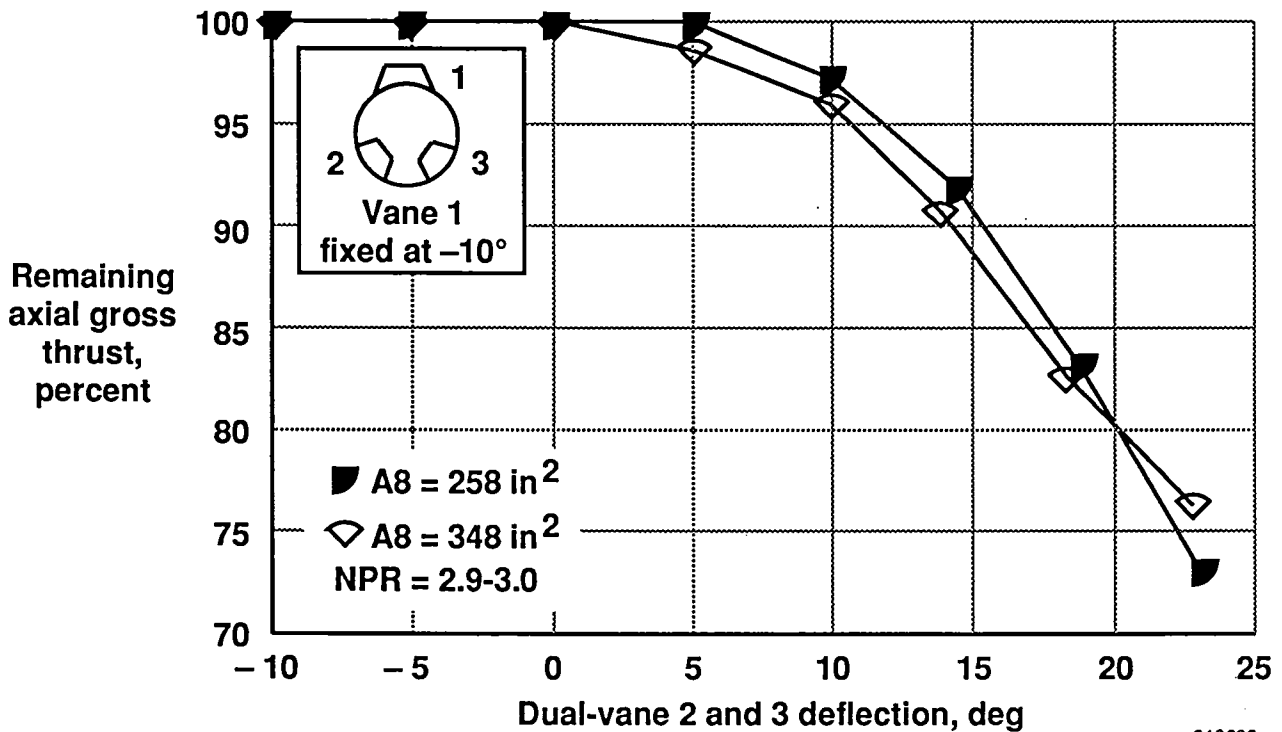
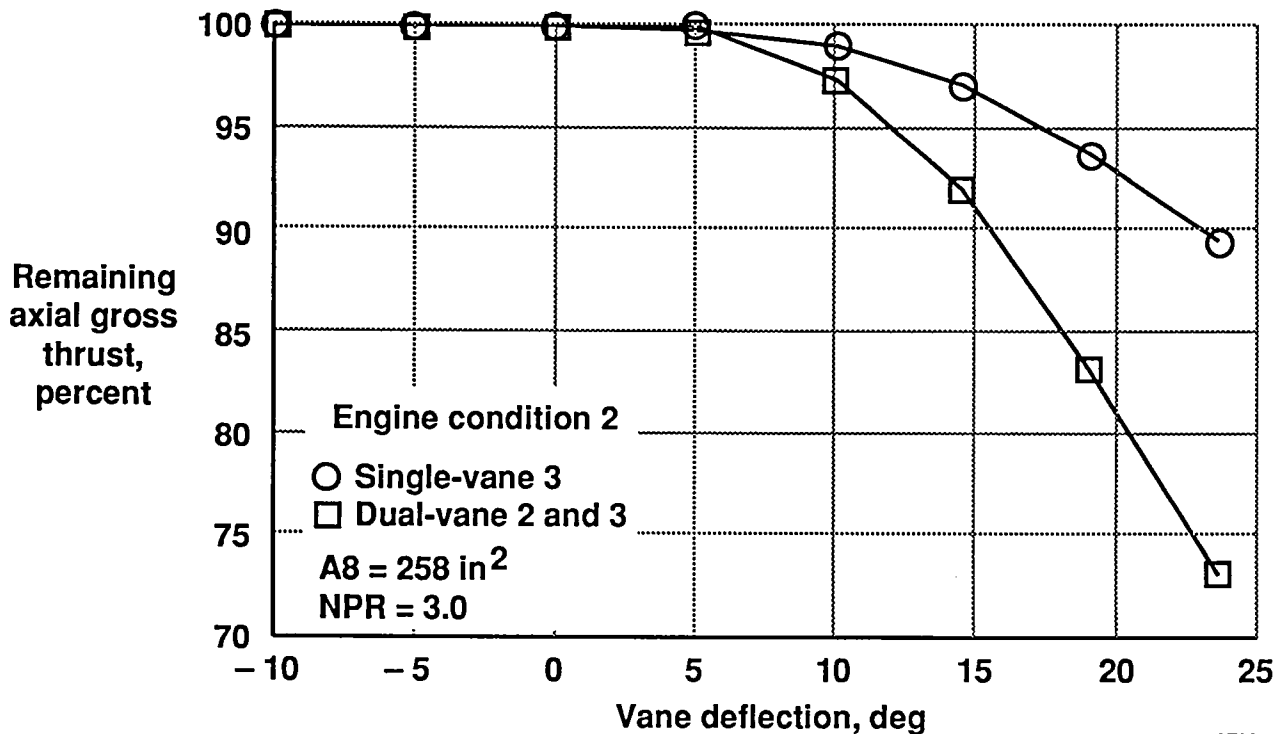

Figure 12. Effects of nozzle throat area on axial gross thrust loss as a function of dual-vane deflection angle for the F/A-18 high alpha research vehicle thrust vectoring test.

Comparison of Single- and Dual-Vane Results

The effects of single- and dual-vane deflections on axial thrust loss for the F/A-18 HARV thrust vectoring test are shown in figure 13. In addition, figure 13 shows axial thrust loss in terms of percent of remaining axial thrust for a single-vane 3 deflection and a symmetric-vane 2 and 3 deflection at engine condition 2. The vanes do not become effective until the deflections increase to above 5°. At vane deflections beyond 5°, the differences in thrust loss between the single- and dual-vanes became greater as the vane-deflection angle increased. As the vanes approached the commanded 25° of deflection, that is, 23° true vane deflection, the dual vanes resulted in substantially more than double the thrust loss of the single vane.



910700

Figure 13. Effects of single- and dual-vane deflection on axial gross thrust loss for F/A-18 high alpha research vehicle thrust vectoring for engine condition 2.

Comparison of F/A-18 High Alpha Research Vehicle and Subscale Model Results

Insight into the validity of using subscale static nozzles to predict thrust vectoring performance was determined by comparing the NASA Langley cold-jet axial thrust loss caused by vane deflection with the F/A-18 HARV results for similar test conditions. Figures 14 through 19 present axial thrust loss caused by thrust vectoring with turning vanes for single-vane 3 and symmetric-vane 2 and 3 deflections with variations of NPR and A8. The NASA Langley cold-jet axial thrust loss data exists for deflection ranges of 10 to 25° for the single-vane deflections and 0 to 25° for the dual-vane deflections. The NASA Langley results are the cold-jet test data which were linearly interpolated with respect to A8, NPR, and true aircraft vane-deflection angle.

Single-Vane 3 Deflections

Figures 14 to 16 show comparison of the NASA Langley cold-jet and the F/A-18 HARV results of axial thrust loss caused by single-vane 3 deflections for three engine conditions. For all three engine conditions, the vanes did not become effective until the vane 3 deflections were increased to above 5°. As vane deflection increased from 10° to the commanded 25°, the full-scale F/A-18 HARV results showed consistently more axial gross thrust loss than the subscale model results. Table 2 highlights the thrust loss comparisons for the commanded vane-deflection angles of 15 and 25°. The differences in percent of thrust loss between the NASA Langley cold-jet and the F/A-18 HARV cold-jet results ranged from 0.89 to 3.25 percent.

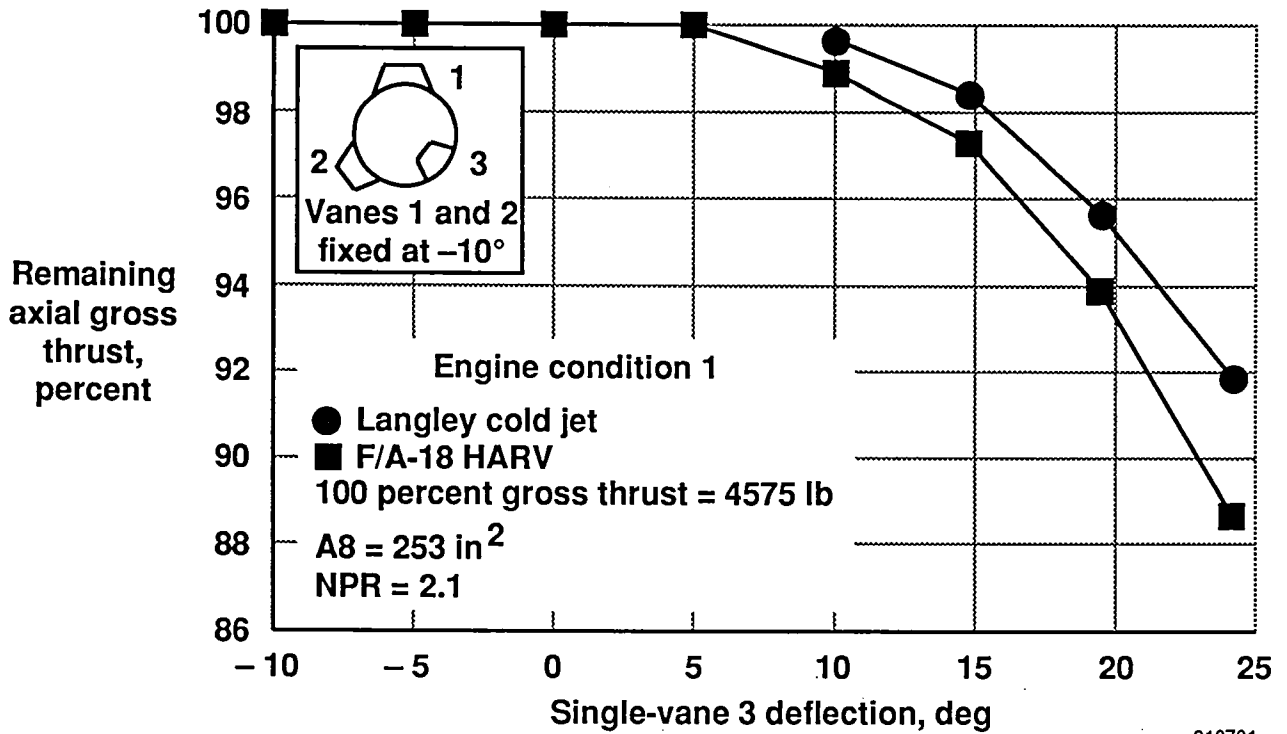

910701

Figure 14. Comparison of the NASA Langley subscale model and the F/A-18 high alpha research vehicle thrust loss as a function of single-vane deflection angle for engine condition 1.

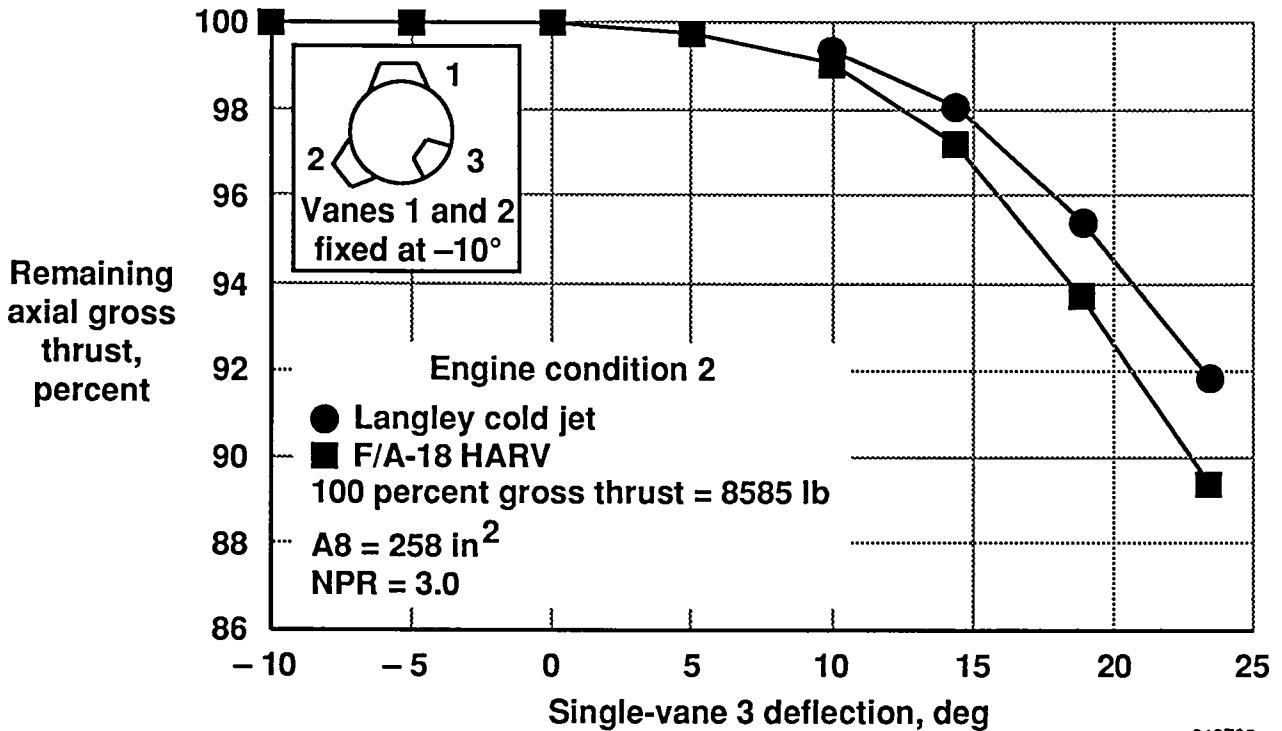

910702

Figure 15. Comparison of the NASA Langley subscale model and the F/A-18 high alpha research vehicle thrust loss as a function of single-vane deflection angle for engine condition 2.

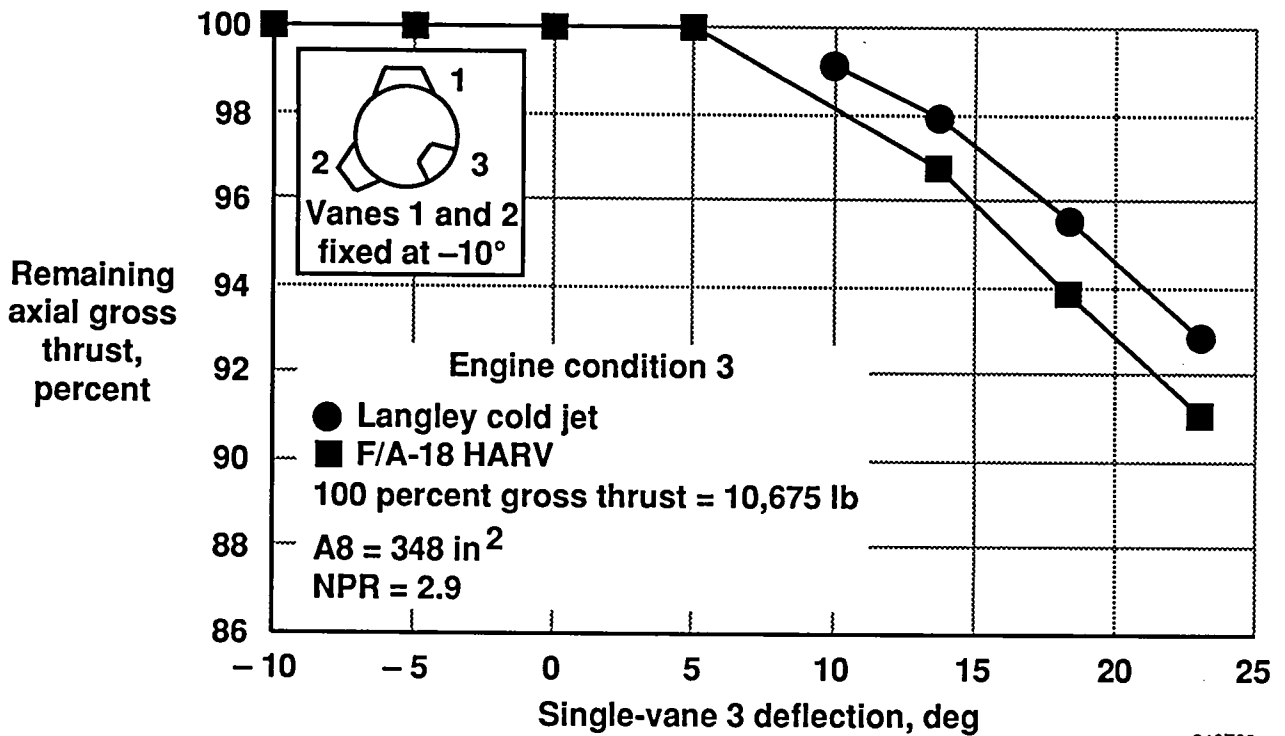

Figure 16. Comparison of the NASA Langley subscale model and the F/A-18 high alpha research vehicle thrust loss as a function of single-vane deflection angle for engine condition 3.

Table 2. Single-vane 3 F/A-18 high alpha research vehicle and NASA Langley cold-jet axial thrust loss comparisons for selected vane-deflection angles.

Vane deflection	PLA, deg	NPR	A8, in ²	F/A-18 HARV thrust loss, percent	Cold-jet thrust loss, percent	Difference, percent thrust
0.00	61	2.1	253	0.00	---	---
14.77	↓	↓	↓	2.73	1.58	1.15
24.22	↓	↓	↓	11.37	8.12	3.25
0.00	87	3.0	258	0.00	---	---
14.44	↓	↓	↓	2.81	1.92	0.89
23.45	↓	↓	↓	10.60	8.13	2.47
0.00	110	2.9	348	0.00	---	---
13.77	↓	↓	↓	3.24	2.08	1.16
23.08	↓	↓	↓	8.90	7.12	1.78

Dual-Symmetric-Vane 2 and 3 Deflections

Figures 17 to 19 show comparison of the NASA Langley cold-jet and the F/A-18 HARV results of axial thrust loss caused by symmetric-vane 2 and 3 deflections for the same three engine conditions. For all three engine conditions, the vanes did not become effective until the dual-vane deflections were increased to between 0 and 5°. As the commanded vane deflections were increased from 10 to 25°, again, the full-scale F/A-18 HARV results showed consistently more axial gross thrust loss than the subscale model results. Table 3 highlights the thrust loss comparisons for commanded dual-vane deflection angles of 0, 15, and 25°. For the dual-vane deflections, the differences in percent of thrust loss between the NASA Langley cold-jet and the F/A-18 HARV results were as high as 5.16 percent. As the vane-deflection angles increased, these differences became greater. The different scales, exhaust gas temperatures, and exhaust gas velocities which exist between the F/A-18 HARV and static nozzle tests performed at the NASA Langley 16-ft Transonic Tunnel Cold Jet Facility were the most probable causes of underprediction of the magnitude of the axial gross thrust loss.

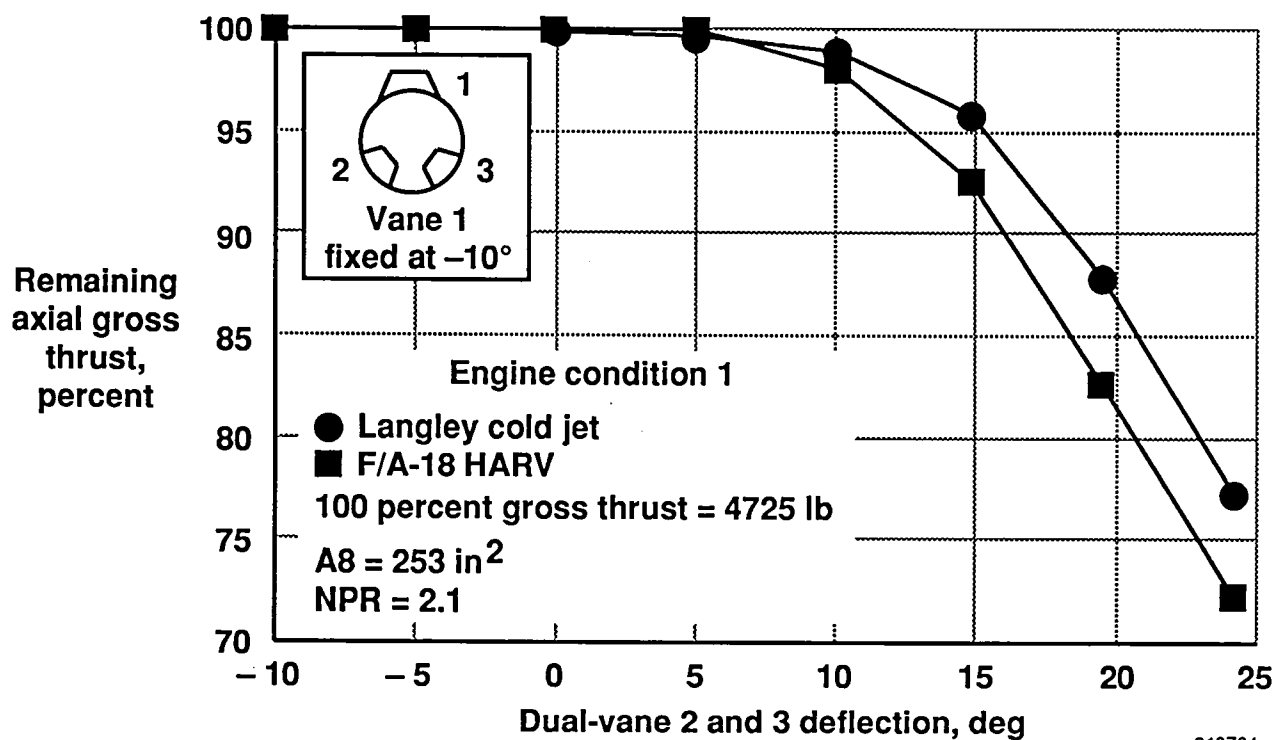

910704

Figure 17. Comparison of the NASA Langley subscale model and the F/A-18 high alpha research vehicle thrust loss as a function of dual-vane deflection angle for engine condition 1.

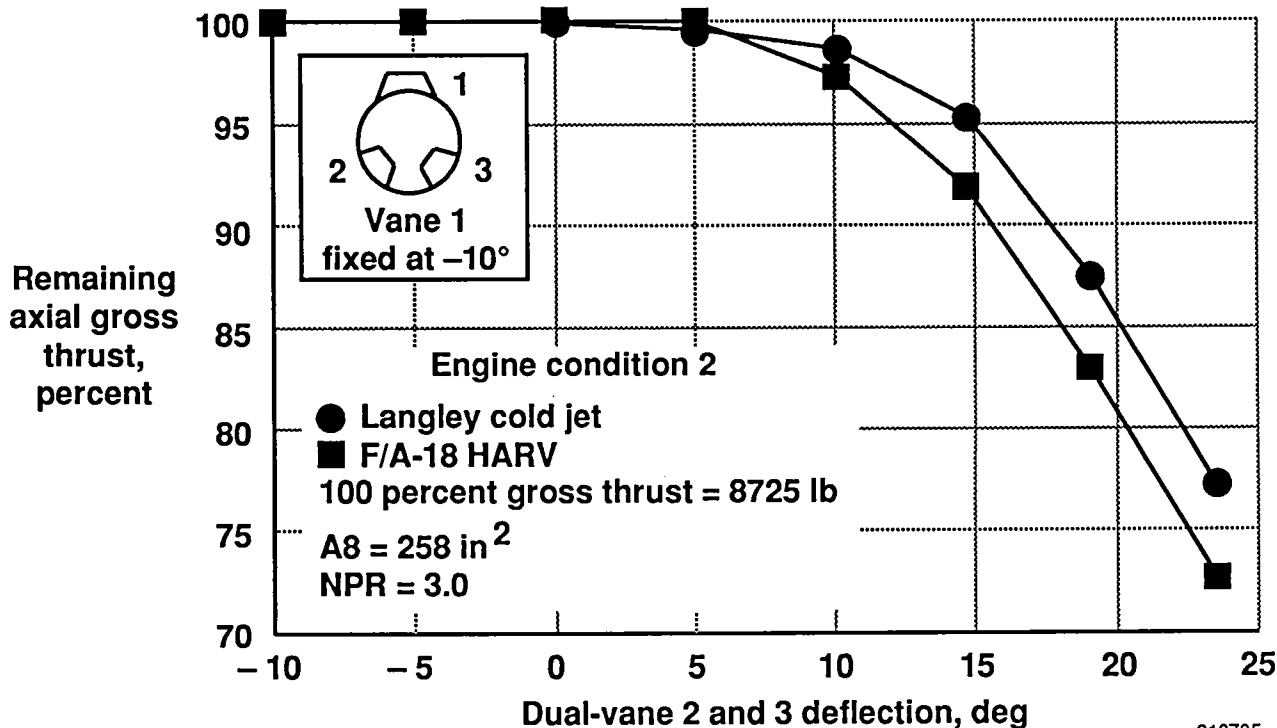

Figure 18. Comparison of the NASA Langley subscale model and the F/A-18 high alpha research vehicle thrust loss as a function of dual-vane deflection angle for engine condition 2.

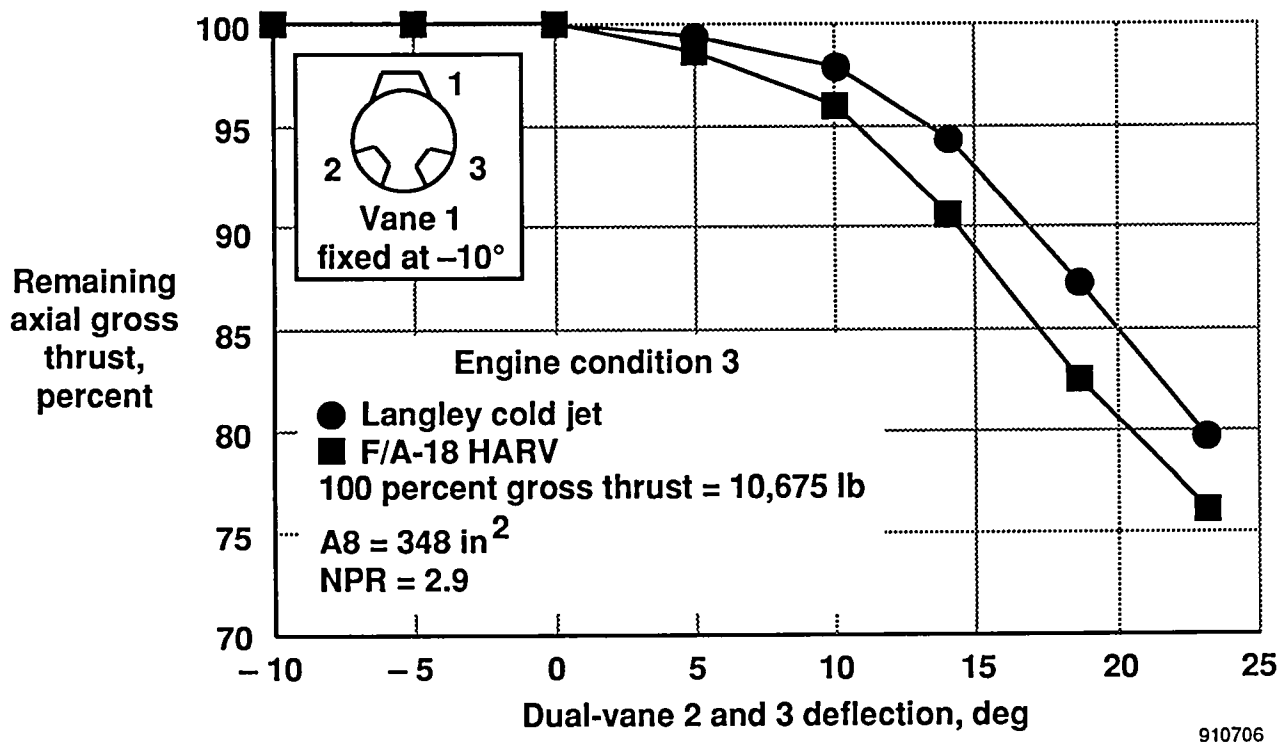

Figure 19. Comparison of the NASA Langley subscale model and the F/A-18 high alpha research vehicle thrust loss as a function of dual-vane deflection angle for engine condition 3.

Table 3. Dual-vane 2 and 3 F/A-18 high alpha research vehicle and NASA Langley cold-jet axial thrust loss comparisons for selected vane-deflection angles.

Vane deflection	PLA, deg	NPR	A8, in ²	F/A-18 HARV thrust loss, percent	Cold-jet thrust loss, percent	Difference, percent thrust
0.00	61	2.1	253	0.00	0.06	0.06
14.81	↓	↓	↓	7.41	4.12	3.29
24.17	↓	↓	↓	27.94	22.78	5.16
0.00	87	3.0	258	0.00	0.10	0.10
14.57	↓	↓	↓	8.10	4.72	3.38
23.40	↓	↓	↓	27.20	22.66	4.54
0.00	110	2.9	348	0.00	0.01	0.01
14.02	↓	↓	↓	9.41	5.69	3.72
23.08	↓	↓	↓	23.89	20.34	3.55

CONCLUDING REMARKS

A ground test was conducted to determine the amount of axial gross thrust loss caused by thrust vectoring with turning vanes installed on the NASA Dryden Flight Research Facility F/A-18 high alpha research vehicle. A comparison of these results was made for similar test conditions obtained from a NASA Langley Research Center 14.25 percent, subscale, static nozzle test. This comparison revealed the following findings:

1. The model accurately predicted thrust loss characteristics.
 - The model and aircraft indicated a slight increase in thrust loss with increased nozzle pressure ratio.
 - The model and aircraft indicated an increase in thrust loss with the larger nozzle throat area up to 20° dual-vane deflection. Above 20° dual-vane deflection, both model and aircraft showed an increase in thrust loss with the smaller nozzle throat area.
2. The model consistently underpredicted the magnitude of thrust loss by approximately 1 to 4.5 percent in axial thrust.
3. The dual-vane losses were more than double the single-vane losses.

These full-scale F/A-18 high alpha research vehicle thrust vectoring results helped to validate the thrust vectoring performance predictions generated with small static (no external flow) nozzles using room temperature and high-pressure air to simulate the jet-exhaust flow. The different scales, exhaust gas temperatures, and exhaust gas velocities which exist between the F/A-18 high alpha research vehicle and the static nozzle tests performed at the NASA Langley Research Center 16-ft Transonic Tunnel Cold Jet Facility were the most probable causes of underprediction of the magnitude of the axial gross thrust loss.

REFERENCES

1. Berrier, Bobby L., *Results from NASA Langley Experimental Studies of Multiaxis Thrust Vectoring Nozzles*, SAE TP-881481, Oct. 1988.
2. Capone, Francis J., "Performance Characteristics of Nonaxisymmetric Nozzles Installed on the F-18 Airplane," AIAA 79-0101, Jan. 1979.
3. Capone, Francis J. and Mary L. Mason, *Multiaxis Aircraft Control Power From Thrust Vectoring at High Angles of Attack*, NASA TM-87741, 1986.
4. Mason, Mary L. and Bobby L. Berrier, *Static Performance of Nonaxisymmetric Nozzles With Yaw Thrust-Vectoring Vanes*, NASA TP-2813, 1988.
5. Sappington, Jeffrey W. and Robert L. Thompson, "F-14A Yaw Vane Technology Demonstration Program," *31st Symposium Proceedings*, Society of Experimental Test Pilots, Sept. 1987, pp. 187-200.
6. Herbst, W.B., "Future Fighter Technologies," *J. Aircraft*, vol. 17, no. 8, 1988, pp. 561-566.
7. Seeck, Dietrich and Ken Dyson, "An Introduction to the X-31," *33d Symposium Proceedings*, Society of Experimental Test Pilots, Sept. 1989, pp. 112-121.
8. Gilbert, William P., Luat T. Nguyen, and Joseph Gera, "Control Research in the NASA High-Alpha Technology Program," *AGARD Fluid Dynamics Panel Symposium on Aerodynamics of Combat Aircraft Control and of Ground Effects*, Oct. 1989, pp. 3-1 to 3-18.
9. Berrier, Bobby L. and Mary L. Mason, *Static Performance of an Axisymmetric Nozzle With Post-Exit Vanes for Multiaxis Thrust Vectoring*, NASA TP-2800, 1988.
10. Bowers, Albion H., et al., *Multiaxis Thrust Vectoring Using Axisymmetric Nozzles and Postexit Vanes on an F/A-18 Configuration Vehicle*, NASA TM-101741, 1991.
11. *F404-400 Training Guide*, SEI-477, G.E. Aircraft Engines, 1989.

REPORT DOCUMENTATION PAGE

Form Approved
OMB No. 0704-0188

Public reporting burden for this collection of information is estimated to average 1 hour per response, including the time for reviewing instructions, searching existing data sources, gathering and maintaining the data needed, and completing and reviewing the collection of information. Send comments regarding this burden estimate or any other aspect of this collection of information, including suggestions for reducing this burden, to Washington Headquarters Services, Directorate for Information Operations and Reports, 1215 Jefferson Davis Highway, Suite 1204, Arlington, VA 22202-4302, and to the Office of Management and Budget, Paperwork Reduction Project (0704-0188), Washington, DC 20503.

1. AGENCY USE ONLY (Leave blank)		2. REPORT DATE January 1992	3. REPORT TYPE AND DATES COVERED Technical Memorandum	
4. TITLE AND SUBTITLE Aircraft Ground Test and Subscale Model Results of Axial Thrust Loss Caused by Thrust Vectoring Using Turning Vanes			5. FUNDING NUMBERS RTOP 505-68	
6. AUTHOR(S) Steven A. Johnson				
7. PERFORMING ORGANIZATION NAME(S) AND ADDRESS(ES) NASA Dryden Flight Research Facility P.O. Box 273 Edwards, California 93523-0273			8. PERFORMING ORGANIZATION REPORT NUMBER H-1743	
9. SPONSORING/MONITORING AGENCY NAME(S) AND ADDRESS(ES) National Aeronautics and Space Administration Washington, DC 20546-0001			10. SPONSORING/MONITORING AGENCY REPORT NUMBER NASA TM-4341	
11. SUPPLEMENTARY NOTES				
12a. DISTRIBUTION/AVAILABILITY STATEMENT Unclassified — Unlimited Subject Category 05			12b. DISTRIBUTION CODE	
13. ABSTRACT (Maximum 200 words) The NASA Dryden Flight Research Center F/A-18 high alpha research vehicle was modified to incorporate three independently controlled turning vanes located aft of the primary nozzle of each engine to vector thrust for pitch and yaw control. Ground-measured axial thrust losses were compared with the results from a 14.25 percent cold-jet model for single- and dual-vanes inserted up to 25° into the engine exhaust. Data are presented for nozzle pressure ratios of 2.0 and 3.0 and nozzle exit areas of 253 and 348 in ² . The results of this study indicate that subscale static nozzle test results properly predict trends but underpredict the full-scale results by approximately 1 to 4.5 percent in thrust loss.				
14. SUBJECT TERMS Axial thrust loss; Cold-jet nozzle; F/A-18 high alpha research vehicle; Jet exhaust turning vanes; Thrust vectoring			15. NUMBER OF PAGES 32	
			16. PRICE CODE A03	
17. SECURITY CLASSIFICATION OF REPORT Unclassified	18. SECURITY CLASSIFICATION OF THIS PAGE Unclassified	19. SECURITY CLASSIFICATION OF ABSTRACT Unclassified	20. LIMITATION OF ABSTRACT Unlimited	

**National Aeronautics and
Space Administration
Code NTT-4**

**Washington, D.C.
20546-0001**

Official Business
Penalty for Private Use, \$300

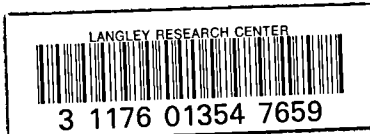

**BULK RATE
POSTAGE & FEES PAID
NASA
Permit No. G-27**



**POSTMASTER: If Undeliverable (Section 158
Postal Manual) Do Not Return**
