

JOHNSON SPACE CENTER'S REGENERATIVE LIFE SUPPORT SYSTEMS TEST BED

Donald L. Henninger, Terry O. Tri, Daniel J. Barta, and Randal S. Stahl
 Life Support Systems Branch/EC3, National Aeronautics and Space Administration, Lyndon B.
 Johnson Space Center, Houston, TX 77058.

ABSTRACT

The Regenerative Life Support Systems (RLSS) Test Bed at NASA's Johnson Space Center is an atmospherically closed, controlled environment facility for the evaluation of regenerative life support systems using higher plants in conjunction with physicochemical life support systems. When completed, the facility will be comprised of two large scale plant growth chambers, each with approximately 10 m² growing area. One of the two chambers, the Variable Pressure Growth Chamber (VPGC), will be capable of operating at lower atmospheric pressures to evaluate a range of environments that may be used in Lunar or Martian habitats; the other chamber, the Ambient Pressure Growth Chamber (APGC) will operate at ambient atmospheric pressure. The root zone in each chamber will be configurable for hydroponic or solid media systems. Research will focus on 1) *in situ* resource utilization for CELSS systems, in which simulated lunar soils will be used in selected crop growth studies; 2) integration of biological and physicochemical air and water revitalization systems; 3) effect of atmospheric pressure on system performance; and 4) monitoring and control strategies.

INTRODUCTION

In the latter half of 1989, the Crew and Thermal Systems Division at NASA, Johnson Space Center, initiated an effort to define, conceptualize, design, fabricate, and test an advanced regenerative life support systems (RLSS) test facility. This facility was designed to integrate, on a large scale, biological and physicochemical life support subsystems, including those providing air and water revitalization, food production, and waste regeneration. Higher plants were chosen to be used over algae-based systems because of their productivity, nutritive value and ease in food processing (1.5, 8, 9.5). Candidate physicochemical subsystems for air and water regeneration included those developed for the Extended Duration Orbiter and Space Station Freedom. The ultimate goal for this continuing effort is to develop RLSS approaches which could be integrated into a human-rated test facility capable of sustaining a multiple-person crew for extended durations.

Chosen as the initial building block of the test bed was one of CTSD's several vacuum chambers, which had been used since early in the space program to vacuum test various hardware systems. The chamber had an attached airlock and was considered ideal for conducting reduced-pressure plant growth experiments. During the first phase of the test bed development, the selected vacuum chamber was outfitted with automated plant growth systems (Figure 1). Ambient pressure operations were targeted for this first phase, with reduced pressure capabilities to be added in the second phase of buildup. This chamber was termed the variable pressure growth chamber (VPGC). Also included in the second phase was outfitting of a second plant growth chamber of comparable dimensions to be operated only at ambient pressures. This chamber was termed the ambient pressure growth chamber (APGC). In the third phase, incorporation of physicochemical life support subsystems was planned, along with integration of a human metabolic simulator.

The RLSS test bed was designed to support the growth of higher plants under a range of environmental conditions, including reduced atmospheric pressure (Table 1). The plant root zone in each chamber will be configurable for hydroponic or solid media systems. *In situ* resource utilization for RLSS systems will be investigated, with emphasis on use of lunar soils for crop growth (6).

(NASA-TM-107943) JOHNSON SPACE CENTER'S
 REGENERATIVE LIFE SUPPORT SYSTEMS TEST BED
 (NASA) 11 p

N92-28157

unclas
 G3/54 0106535

Table 1. Requirements for operating ranges of selected environmental parameters.

Subsystem and parameter	Range of Operation	Units
<u>Ventilation and thermal control</u>		
Air temperature	16-35	°C
Relative humidity	60-95	%
<u>Atmospheric control</u>		
Air velocity	0.1-1.0	m s ⁻¹
Oxygen	18.5-23.0	%
Carbon dioxide	350-2000	μL L ⁻¹
Chamber operating pressure	70-101*	kPa
<u>Radiation</u>		
Photosynthetically active radiation	0-500	μmol m ⁻² s ⁻¹
Photoperiod	0-24	h
<u>Nutrient Delivery</u>		
Solid substrate configuration		
Irrigation rate	45†	ml sec ⁻¹ m ⁻²
Irrigation lines	45†	number m ⁻²
Hydroponic configuration		
pH	4.5-8.0	pH
Conductivity	50-300	mS m ⁻¹
Flow rate	4-8	L min ⁻¹ m ⁻²
Plant density	6-2000	plants m ⁻²

* VPGC only. APGC will operate at ambient pressures only.

† Under current configuration.

DESIGN

Chamber Outfitting

The VPGC was constructed by outfitting a vacuum test chamber with subsystems necessary to support plant growth (Figure 1). It was originally used for testing life support subsystems under varied temperature, humidity and atmospheric pressure conditions (1). Its vacuum operation was limited to 34.5 kPa (5 psia). The 2.7-m-wide (8.9 ft) by 2.4-m-tall (7.9 ft) chamber is divided into two compartments, a 3.0-m-long (9.8 ft) airlock and a 4.2-m-long (13.8 ft) main compartment. The main compartment, which encloses a volume of 27 m³ (962 ft³), was outfitted for plant growth. The airlock will support chamber entry during reduced pressure tests and will eventually be outfitted for habitation by human subjects. The chamber interior is insulated with a 2.5 cm (1 in) layer closed cell foam. The APGC has the similar internal dimensions. It was constructed using modular wall panels having an insulation factor of R-9. The two plant growth chambers are joined by an entry room. The layout of the test bed facility is illustrated in Figure 2.

The total growing area within the VPGC and APGC is 10.5 and 11.4 m² (113 and 123 ft²), respectively. The interior of each chamber is divided into eight distinct growing areas (Figure 3). Each growing area is equipped with an adjustable plant growth tray, an array of fluorescent lamps, a ventilation panel equipped with adjustable louvers and various environmental sensors.

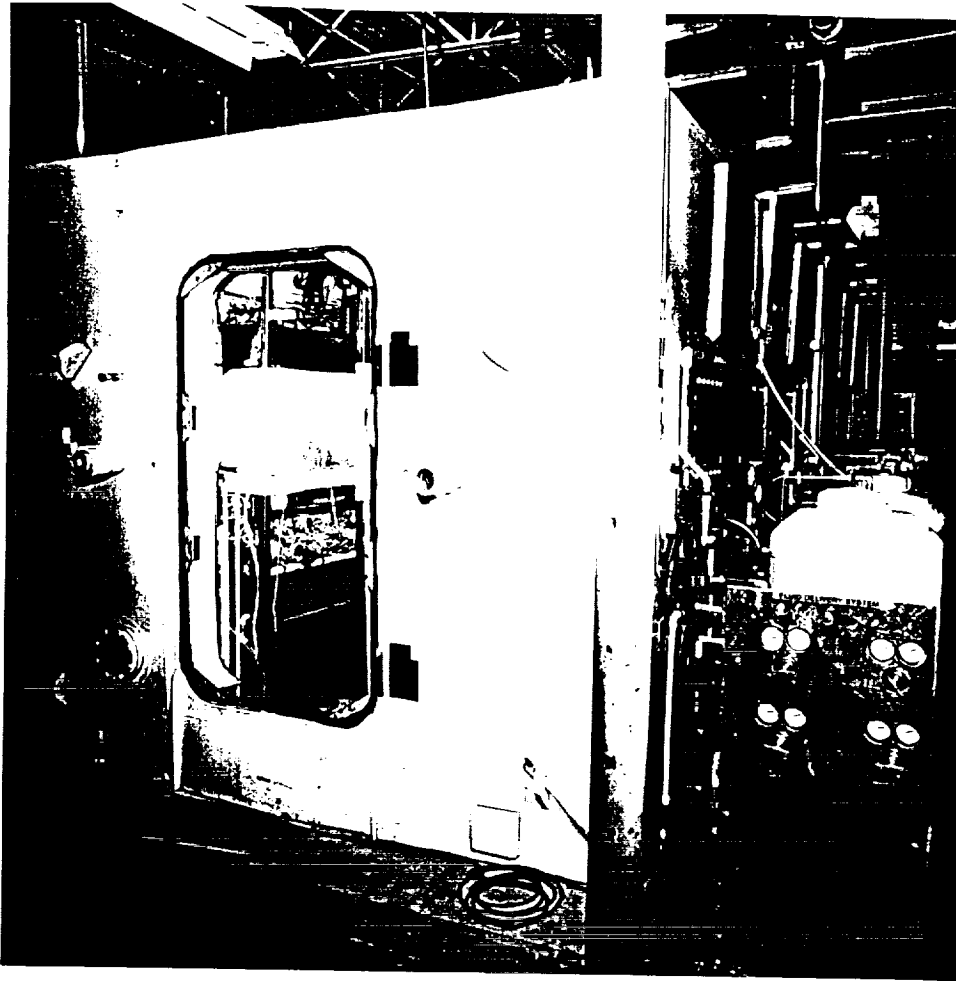

Figure 1. The Variable Pressure Growth Chamber (VPGC), configured during phase 1 buildup for operation at ambient atmospheric pressure. Fluid delivery systems are to the right of the chamber. The bulkhead on the end wall has been removed to expose the chamber's interior.

The growing areas are stacked in pairs, the upper growing area is directly above the lower. A narrow aisle divides each chamber into two unique sides, each with two pairs of growing areas. The atmospheric conditioning for each side is provided by a separate atmospheric conditioning column centrally located between each pair of growing areas.

The materials used inside both growth chambers were selected to pose no hazards to higher plants or humans. Properties of materials, such as off-gassing, corrosion, and leaching, were considered (4,9).

During planned and contingency manned operations inside the chambers, communications between personnel in the chamber and in the control room are essential for reasons of safety and operational efficiency. Communications systems are present consisting of a head sets and microphones, located both inside the chamber and in the control room, which allow the occupant in the chamber to converse with test operations personnel stationed in the control room. In addition, video cameras mounted within the chambers provide a visual and audio record of activities. Provisions are present for time-lapse video and time-lapse photography of crop growth.

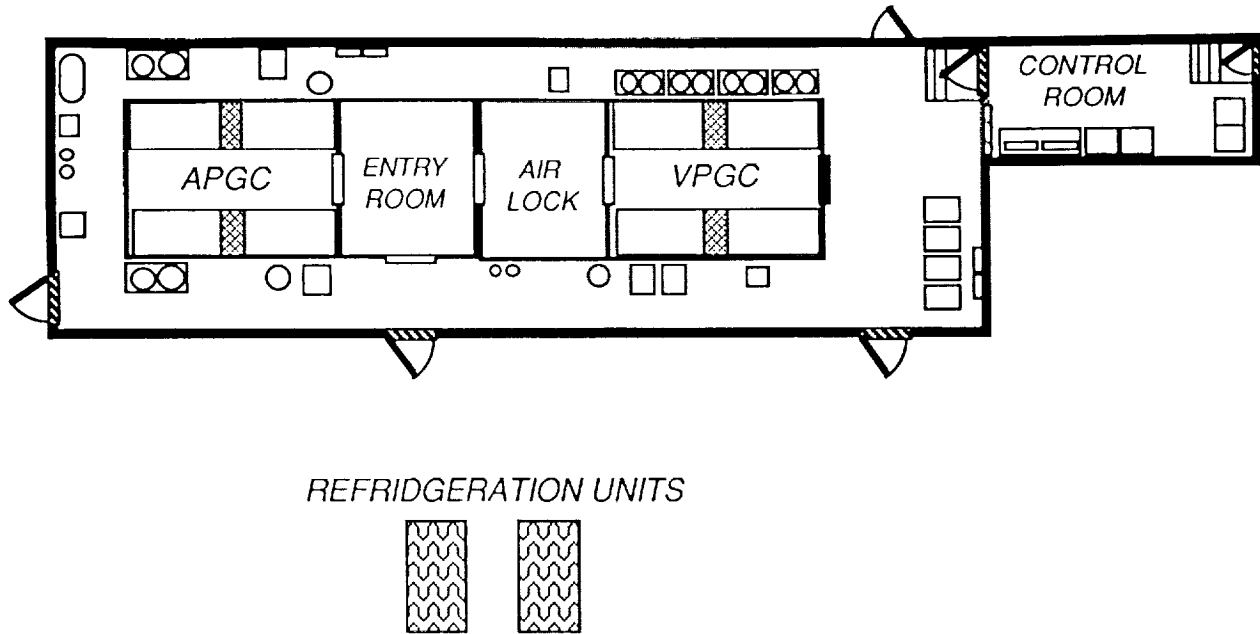

Figure 2. Regenerative Life Support Systems (RLSS) Test Bed Facility layout, with ambient pressure growth chamber (APGC) and variable pressure plant growth chamber (VPGC).

Photosynthetic Lighting Systems

The banks of lamps above each growing area contain ten 1.8 m (72 in) 1500 mA cool-white fluorescent lamps. These provide a maximum photosynthetic photon flux (PPF) of $500 \mu\text{mol m}^{-2} \text{s}^{-1}$ 10 cm below the lamp bank. A 3 mm (.125 in) thick polycarbonate sheet (Lexan™) is mounted beneath the fluorescent lamps to absorb longwave radiation. This barrier also aids in channeling air across the bulbs for cooling to increase bulb output efficiency. The ballasts are mounted outside the chambers.

Thermal Control and Ventilation Systems

The atmospheric conditioning columns, centrally located on each side of each chamber, deliver conditioned air to ventilation panels in the back of each growing area (Figure 4). The air stream passes through adjustable louvers which direct air uniformly across the plant canopy. Air returns to the atmospheric conditioning system by passing through the lamp banks. A coarse polyester filter on the inlets keep large particulates from entering the lamp banks. Baffles installed in the lamp banks channel air flow to improve bulb cooling. The air stream is cooled by an A-frame condensing heat exchanger to the desired dewpoint. Condensed moisture is directed to a tank outside the chamber where it is quantified for measurements of evapotranspiration. Downstream of the heat exchangers are electric heaters that reheat the cooled, dehumidified air to the desired drybulb temperature. A centrifugal blower located at the base of each column circulates air through the closed system at approximately three exchanges per minute. Primary sources of heat within the chamber include the lamps, the blowers, the electric heating elements and latent heat within atmospheric moisture. Chiller units outside each chamber circulate a chilled mixture of H₂O and ethylene glycol through the heat exchangers. The flow of brine through the heat exchanger is modulated by the dewpoint temperature controller.

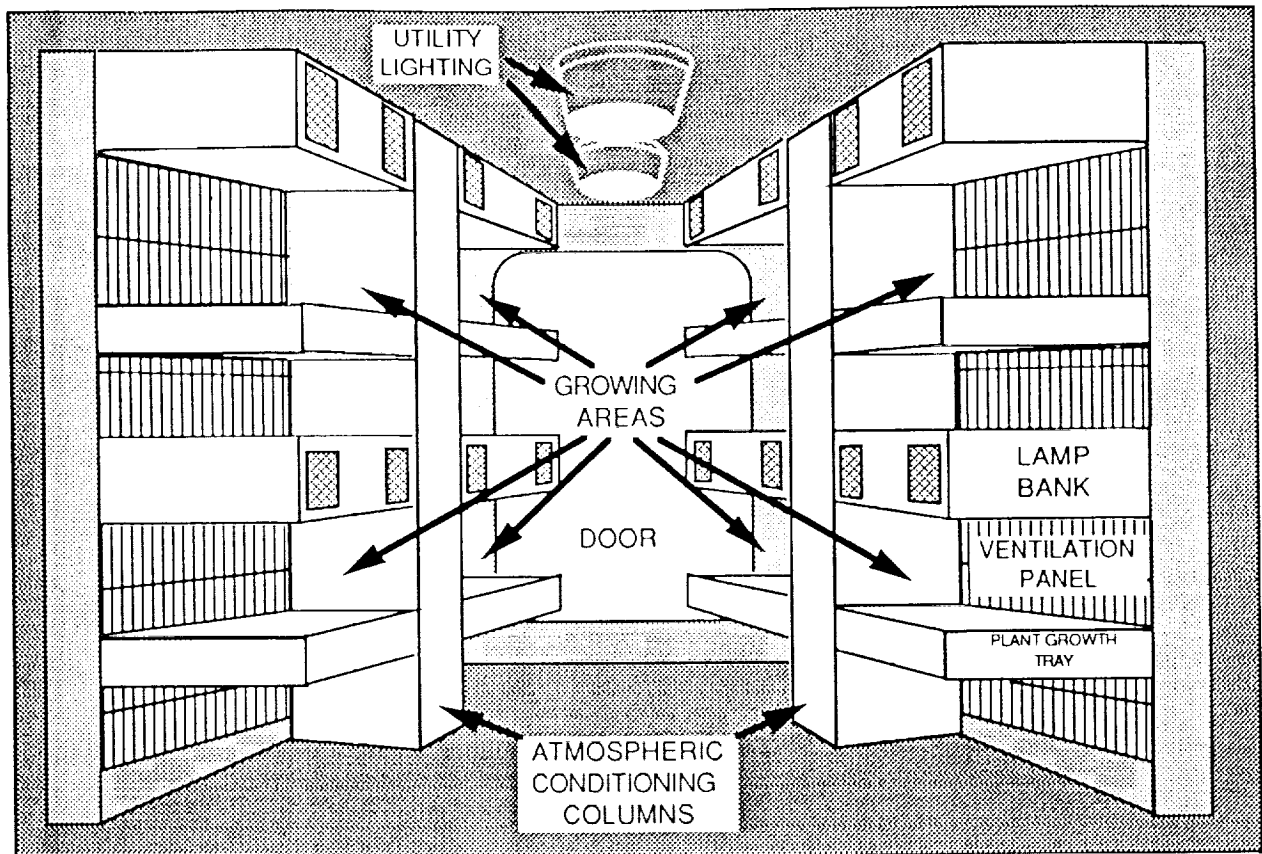

Figure 3. Internal Configuration of the growth chambers.

Gas and Pressure Systems

Both growth chambers were designed to achieve a high degree of atmospheric closure. Gas leakage was minimized by use of standard vacuum chamber sealing methods at all penetrations and by locating the ventilation systems within the chambers.

During ambient pressure operations, the VPGC is connected to an air volume compensation device which allows the controlled volume of air within the chamber to expand and contract in response to variations in internal or external pressure (3). Pressure differences between internal chamber pressure and external ambient pressure may result from changes in chamber temperature (11) or from changes in barometric pressure due to weather. The volume compensation device allows the closed chamber atmospheric pressure to equalize with the external ambient pressure environment, thus reducing atmospheric leakage attributable to pressure differentials across the chamber seals. It consists of a heat-sealed urethane-coated nylon bladder which represents approximately one tenth of the VPGC's internal volume. The bladder is freely suspended in a rigid support frame by flexible support straps. It is plumbed directly to the chamber and behaves as an expandable dead air space. It is also plumbed to a breathing air pressurization system which allows the bladder to be inflated to a specific level for optimum performance.

The VPGC is currently operable at ambient atmospheric pressure. Designs are in work to provide vacuum pumping systems which will enable the chamber to operate at 70.3 kPa (10.2 psia). Testing of regenerative life support systems using higher plants at modified atmospheric pressures is important because the baseline atmospheric pressure for a lunar or Mars outpost has not yet been determined and because little is known concerning long term response of these

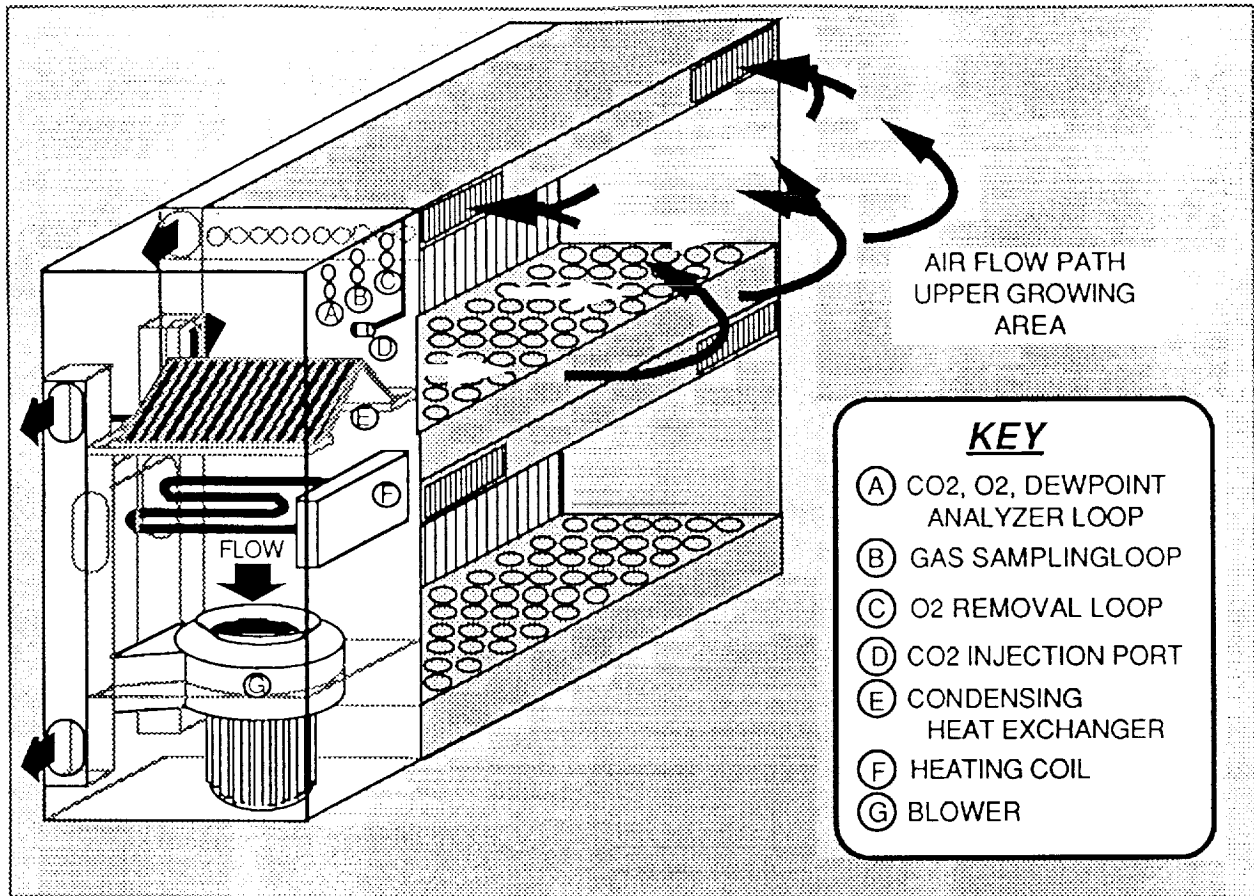

Figure 4. Schematic of atmospheric conditioning column with pair of plant growth areas.

systems at reduced pressures. Modifications for reduced pressure operation are scheduled to be completed during the later half of 1992.

Gas composition within both chambers is maintained through active injection of carbon dioxide (CO_2) and removal of oxygen (O_2). Samples of chamber atmosphere are pulled continuously from a point within each atmospheric conditioning column and pass through a series of gas analyzers before returning to the chamber. The sample lines are insulated and heated with heating tape to prevent condensation of water vapor. The air stream passes through a chilled mirror digital humidity analyzer (EG&G, model 911 Dew All™), a cold trap to remove water vapor, a paramagnetic oxygen analyzer (Beckman Industrial, model 755), and finally, an infrared gas analyzer (Beckman Industrial, model 880) to measure CO_2 concentration. A separate set of analyzers is used for each side of each chamber, adding a degree of redundancy. Carbon dioxide concentrations are maintained above a minimum level by pulsed injection of CO_2 gas from a bottle supply. Oxygen concentrations are maintained below a maximum level by activation of a molecular sieve O_2 removal system (DeVilbiss, model PVO2D). Oxygen is collected in a set of 0.9 m^3 (240 gallon) storage tanks for later analysis or is vented to the atmosphere.

Additional sample lines connect each chamber to a gas chromatograph-mass spectrometer (GC/MS) system (Hewlett Packard, models 5880A & 5987A). The GC/MS system is calibrated for measurement of volatile organics having molecular weights between 33 and 300 atomic mass units. A pump circulates the chamber atmosphere through the sample lines prior to analysis. A second gas chromatograph for measurement of ethylene will be installed later in 1992. Lastly,



Figure 5. View of growing tray in the variable pressure growth chamber (VPGC) configured for solid support substrates.

each chamber is fitted with a system to sense ammonia vapor. If elevated levels of ammonia are detected, an alarm is initiated.

The APGC is currently being outfitted with a dual-function fluid delivery system, capable of supporting both solid support substrate and hydroponic cultural systems (Figure 6). When configured for hydroponic operation, the nutrient solution will be continuously recirculated through the system at rates from 4 to 8 liters $\text{min}^{-1} \text{m}^{-2}$ of growing area, depending on the position of the bypass valve. A small percentage of nutrient solution pumped from the supply tank to the hydroponic growth trays will be diverted to a sensor loop containing redundant pH and electrical conductivity sensors. Nutrient solution concentrates will be injected into the supply tank to maintain the desired electrical conductivity of the solution. Similarly, acid or base stock solutions will be injected to maintain the desired pH setpoint. Dissolved oxygen sensors in nutrient supply and return plumbing will be used to characterize dissolved oxygen levels. An oil-free diaphragm pump will draw air from the chamber to aerate the solution in the supply tank. Nutrient solution draining from the hydroponic trays into the catchment trays within the chamber will be removed by air-operated double-diaphragm pumps and pumped back into the supply tank. The level of the nutrient solution within the supply tank will be maintained at a prescribed level by automatic additions of heat-exchanger condensate or deionized water.

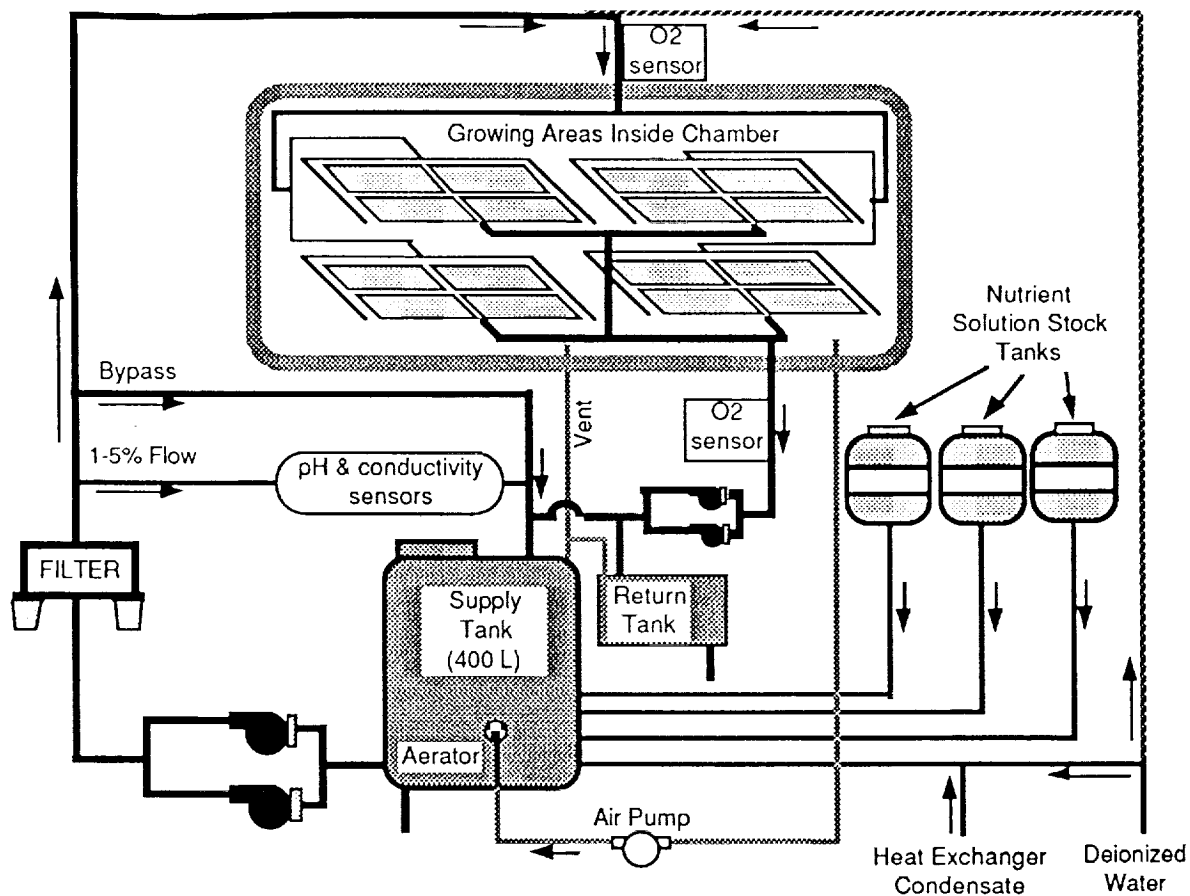

Figure 6. Schematic of fluid delivery system for each side of the ambient pressure growth chamber (APGC).

Nutrient Delivery Systems

During the first phase of buildup, the VPGC was outfitted with a fluid delivery system designed to irrigate pots filled with solid support substrates. A separate fluid delivery and return system services each pair of upper and lower growing areas. Each growing area is configured with an array of sixty pots, as shown in Figure 5. Each pot is connected to an individual fluid delivery line. The fluid delivery lines are connected to a fluid distribution manifold via flow regulators (Pepco, Quadra-bubbler) which provide uniform flow to each pot. A centrifugal pump is operated to supply fluid from 208 liter (55 gal) tanks located outside the chamber. The system provides the capability for automatic delivery of preselected quantities of water or nutrient solution at timed intervals so that autonomous operation of the chamber is possible. Excess fluid drains from the pots into a catchment tray and is directed into the fluid return system. An air-operated double-diaphragm pump draws the excess fluid from the catchment trays of each zone and delivers it to fluid return tanks, where it can be quantified and sampled for elemental or microbiological composition.

Each growing area will have four individual hydroponic trays seated inside a single catchment tray (Figure 7). Each individual tray measures 43 cm (17 in) by 82 cm (32.5 in) and provides 0.36 m² (3.8 ft²) of crop growth area. The depth of the hydroponic tray and the design of its top will vary depending on the particular crop grown. Figure 7 illustrates a hydroponic tray designed for wheat, lettuce and certain other crops. The trays are 6.3 cm (2.5 in) deep and hold a

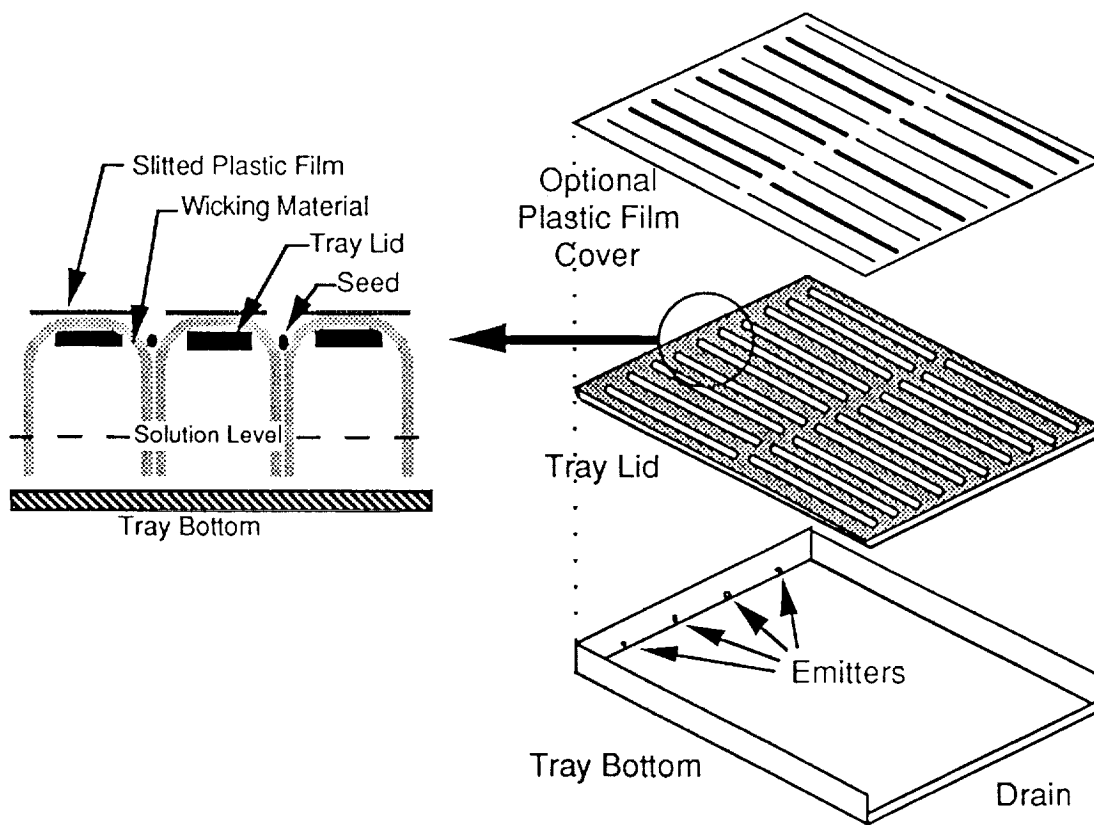

Figure 7. Diagram of the hydroponic tray system planned for use in the ambient pressure growth chamber (APGC).

2.5 cm (1 in) deep layer of nutrient solution. The tray tops support capillary wicks which will accommodate seeding densities as high as 2000 plants m^{-2} .

When the APGC's fluid delivery system is configured for operation with solid substrates, the system will function identically to the fluid delivery system currently used in the VPGC, as described earlier. Solution returning from the chamber will be diverted to a fluid return tank for quantification and sampling.

Computer Data Acquisition and Control Systems

The data acquisition and recording system (DARS) for each chamber is performed by individual Hewlett Packard model 9836 computer systems and attached data acquisition and control units (Hewlett Packard, model 3497A). Each of the two DARS systems monitor environmental conditions and control states, provide tabular and graphical summaries, and perform storage functions. Environmental conditions are screened for out-of-tolerance values. Action is taken based on the severity of the event, which is classified as an "alarm", a "warning" or an "alert". An automatic dialing system contacts key personnel if an "alarm" condition exists, and appropriate, prescribed control actions are taken to correct the problem. A "warning" initiates notification of

key personnel, but corrective action is not taken. An "alert" provides a printed statement of the condition and takes no other action. Primary control of individual subsystems is provided by independent local controllers specific to each supporting subsystem. These subsystem controllers are backed up by the computer system, which can override the local controllers in the event of out-of-tolerance conditions.

SUMMARY

As phased buildup activities progress, the RLSS Test Bed at NASA's Johnson Space Center will continue to provide additional unique capabilities for supporting ongoing RLSS research and development efforts. Data produced by the test bed will be highly beneficial in supporting requirements definition and design of a future NASA human-rated RLSS test facility, which will be essential for eventual development of flight-rated lunar outpost or Martian base regenerative life support hardware.

REFERENCES

1. Anonymous. Crew and Thermal Systems Division vacuum laboratories, user guide. Systems Test Branch Publication STB-F-365 A., NASA Johnson Space Center.
- 1.5 Hoff, J.E., J.M. Howe and C.A. Mitchell. 1982. Nutritional and cultural aspects of plant species selection for a controlled ecological life support system. NASA Contractor Report 166324.
2. Hossner, L.R., D.W. Ming, D.L. Henninger and E.R. Allen. 1991 Lunar outpost agriculture. *Endeavour*, New Series, 15(2):79-85.
3. Hand, D.W. 1973. Techniques for measuring CO₂ assimilation in controlled environment enclosures. *Acta Hort.* 32:133-147.
4. Langhans, R.W. 1987. Construction materials and access. In: (MacElroy, D.T. Smernoff, and J.D. Rummel, eds) *Design, development and use of a ground-based plant growth module*. NASA conference publication 2479, NASA ARC, Moffet Field, CA.
5. MacElroy, D.T. Smernoff, and J.D. Rummel. 1987. *Design, development and use of a ground-based plant growth module*. NASA conference publication 2479, NASA ARC, Moffet Field, CA.
6. Ming, D.W. and D.L. Henninger. 1989 *Lunar Base Agriculture: Soils for plant growth*. American Society of Agronomy, Crop Science Society of America and Soil Science Society of America, Madison, WI.
7. Prince, R.P., and W.M. Knott. 1989. CELSS Breadboard Project at the Kennedy Space Center. In: (D.W. Ming and D.L. Henninger, eds) *Lunar Base Agriculture: Soils for plant growth*. American Society of Agronomy, Crop Science Society of America and Soil Science Society of America, Madison, WI. Pgs 155-163.
8. Salisbury, F.B. 1991. Lunar farming: Achieving maximum yield for the exploration of space. *HortScience* 26(7), 827-833.
9. Tibbitts, T.W. 1978. Air contaminants. In: (Langhans, R.W., ed) *A growth chamber manual*. Comstock, Cornell University Press, Ithaca, NY. Pgs 101-106.

9.5. Tibbitts, T.W. and D.K. Alford. 1982. Use of higher plants in regenerative life support systems. NASA Conference Publication 2231.

10. Tri, T.O., M.F. Brown, M.K. Ewert, S.L. Foerg and M.K. McKinley. 1991. Regenerative life support systems (RLSS) test bed development at NASA-Johnson Space Center. In: Regenerative Life Support Systems and Processes, SP-873, Society of Automotive Engineers, Warrendale, PA.

11. Wheeler, R.F., J.H. Drese, and J.C. Sager. 1991. Atmospheric leakage and condensate production in NASA's biomass production chamber. Effect of diurnal temperature cycles. NASA technical memorandum 103819, NASA-KSC, Florida.