

**NASA
Technical
Memorandum**

NASA TM - 103560

11.15
P-568

**NATIONAL LAUNCH SYSTEM CYCLE I LOADS AND
MODELS DATA BOOK**

By F. Bugg, J. Brunty, G. Ernsberger, D. McGhee,
L. Gagliano, F. Harrington, D. Meyer, and E. Blades

**Structures and Dynamics Laboratory
Science and Engineering Directorate**

June 1992

(NASA-TM-103560) NATIONAL LAUNCH SYSTEM
CYCLE I LOADS AND MODELS DATA BOOK (NASA)
568 p

N92-30215

Unclas
G3/15 0110802



National Aeronautics and
Space Administration

George C. Marshall Space Flight Center

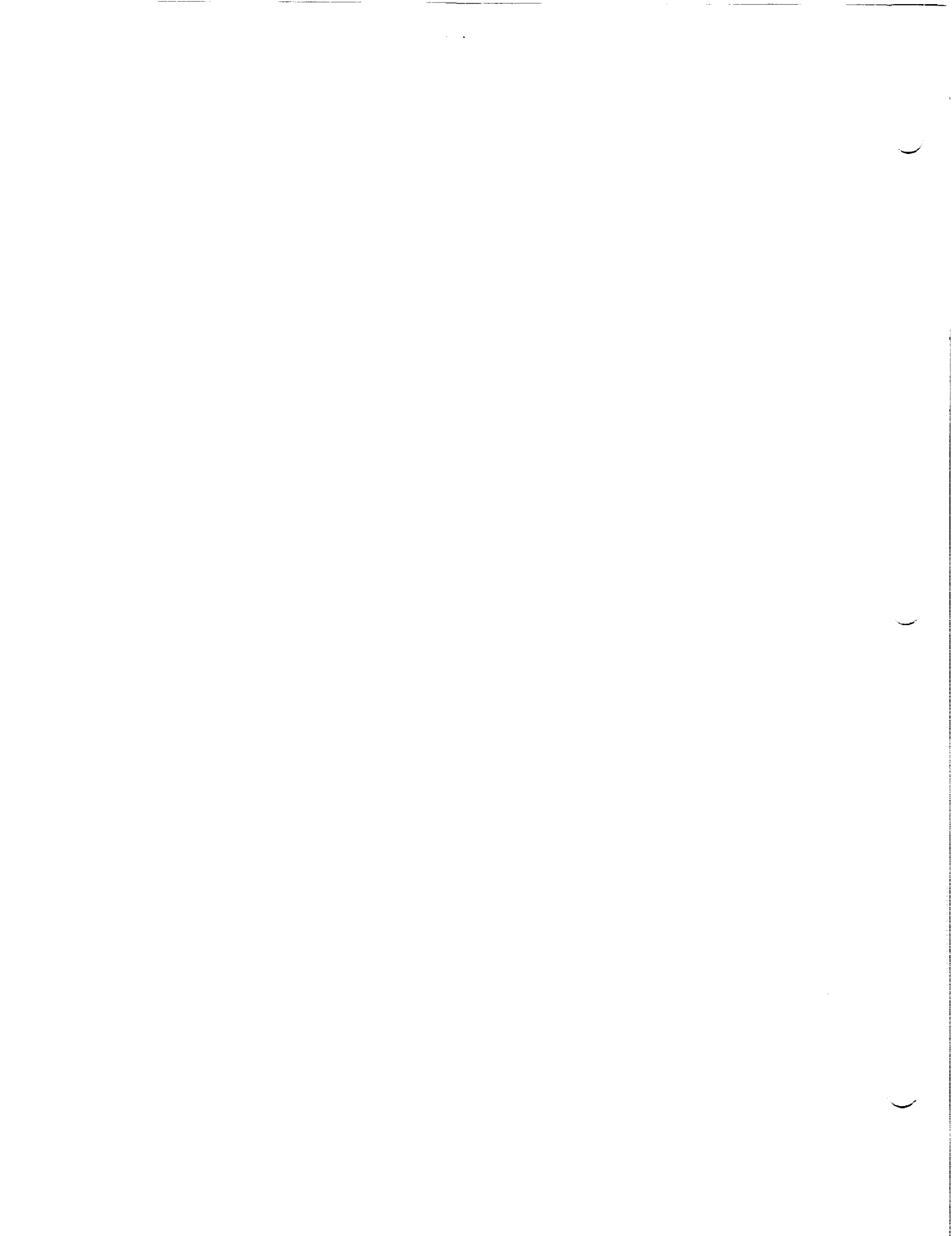

REPORT DOCUMENTATION PAGE			Form Approved OMB No. 0704-0188	
Public reporting burden for this collection of information is estimated to average 1 hour per response, including the time for reviewing instructions, searching existing data sources, gathering and maintaining the data needed, and completing and reviewing the collection of information. Send comments regarding this burden estimate or any other aspect of this collection of information, including suggestions for reducing this burden, to Washington Headquarters Services, Directorate for Information Operations and Reports, 1215 Jefferson Davis Highway, Suite 1204, Arlington, VA 22202-4302, and to the Office of Management and Budget, Paperwork Reduction Project (0704-0188), Washington, DC 20503.				
1. AGENCY USE ONLY (Leave blank)	2. REPORT DATE June 1992	3. REPORT TYPE AND DATES COVERED Technical Memorandum		
4. TITLE AND SUBTITLE National Launch System Cycle 1 Loads and Models Data Book			5. FUNDING NUMBERS	
6. AUTHOR(S) F. Bugg, J. Brunty, G. Ernsberger, D. McGhee, L. Gagliano, F. Harrington, D. Meyer, and E. Blades				
7. PERFORMING ORGANIZATION NAME(S) AND ADDRESS(ES) George C. Marshall Space Flight Center Marshall Space Flight Center, Alabama 35812			8. PERFORMING ORGANIZATION REPORT NUMBER	
9. SPONSORING/MONITORING AGENCY NAME(S) AND ADDRESS(ES) National Aeronautics and Space Administration Washington, DC 20546			10. SPONSORING/MONITORING AGENCY REPORT NUMBER NASA TM-103560	
11. SUPPLEMENTARY NOTES Prepared by Structures and Dynamics Laboratory, Science and Engineering Directorate				
12a. DISTRIBUTION/AVAILABILITY STATEMENT Unclassified-Unlimited			12b. DISTRIBUTION CODE	
13. ABSTRACT (Maximum 200 words) This document contains preliminary cycle 1 loads for the National Launch System NLS 1 and NLS 2 vehicles. The loads provided and recommended as design loads represent the maximum loads expected during prelaunch and flight regimes, i.e., limit loads, except that propellant tank ullage pressure has not been included. Ullage pressure should be added to the loads book values for cases where the addition results in higher loads. The loads must be multiplied by the appropriate factors of safety to determine the ultimate loads for which the structure must be capable.				
14. SUBJECT TERMS NLS, National Launch System Design Loads, Prelaunch, Lift-Off, Assent			15. NUMBER OF PAGES 504	
			16. PRICE CODE NTIS	
17. SECURITY CLASSIFICATION OF REPORT Unclassified	18. SECURITY CLASSIFICATION OF THIS PAGE Unclassified	19. SECURITY CLASSIFICATION OF ABSTRACT Unclassified	20. LIMITATION OF ABSTRACT Unlimited	

TABLE OF CONTENTS

	Page
I. INTRODUCTION	1
II. CONFIGURATION DESCRIPTIONS	2
III. COMMON CORE DESIGN LOADS SUMMARY	3
A. NLS 1 and NLS 2 Overall Line Loads.....	3
B. Interface Design Loads Summary.....	13
C. NLS 2 Modified Titan IV Shroud Design Loads.....	15
D. Comparison With Cycle 0 Baseline Loads	17
IV. STRUCTURAL DYNAMICS AND LOADS MODELS.....	21
A. Data Sources	21
1. Reference Configuration Drawings.....	21
2. Mass Properties	21
B. FORTRAN/NASTRAN Model Bulk Data	21
C. Prelaunch and Lift-Off Model Modes and Frequencies	23
V. LOADING EVENTS.....	23
A. On-Pad (Ground Winds, STME Buildup/Shutdown).....	23
1. Methodology/Assumptions	23
2. Input Data Requirements and Sources	24
a. Ground Winds Criteria	24
b. Forcing Functions/STME's.....	24
3. Loads Results for NLS 2	24
a. Interface Loads/Accelerations	25
b. Distributed Body Loads	25
4. Loads Results for NLS 1	25
a. Interface Loads/Accelerations	26
b. Core Vehicle Distributed Body Loads	27
5. On-Pad Prelaunch Loads Summary	27
B. Lift-Off.....	27
1. Methodology/Assumptions	28
2. Input Data Requirements and Sources	28
a. Ground Winds Criteria	28
b. Forcing Functions.....	29
3. Loads Results for NLS 2	29
a. Interface Loads/Accelerations.....	30
b. Distributed Body Loads	30
4. Loads Results for NLS 1	30
a. Interface Loads/Accelerations.....	31
b. Core Vehicle Distributed Body Loads	31
5. Lift-Off Loads Summary.....	31

TABLE OF CONTENTS (Continued)

	Page
C. Ascent	32
1. Methodology/Assumptions	32
2. Input Data Requirements and Sources	34
a. Vehicle Aerodynamics	34
b. Winds Criteria	35
c. Control System Data.....	35
d. Trajectory Data.....	35
e. Engine-Out Conditions.....	36
3. Loads Results for NLS 2	36
a. Interface Loads	36
b. Distributed Body Loads	36
4. Loads Results for NLS 1	37
a. Interface Loads	37
b. Core Vehicle Distributed Body Loads	38
5. Maximum/Minimum Loads Summary.....	38
REFERENCES.....	40
APPENDIX	43

LIST OF ILLUSTRATIONS

Figure	Title	Page
1.	NLS 1 and NLS 2 reference vehicle	2
2.	NLS 1 with STME out N_x max/min versus X-station.....	3
3.	NLS 1 without STME out N_x max/min versus X-station	4
4.	NLS 2 with STME out N_x max/min versus X-station.....	4
5.	NLS 2 without STME out N_x max/min versus X-station	5
6.	NLS 1 core without STME out N_x event comparison versus X-station.....	5
7.	NLS 2 with STME out N_x event comparison versus X-station.....	6
8.	NLS 2 without STME out N_x event comparison versus X-station	6
9.	NLS 1 and NLS 2 with STME out N_x event comparison versus X-station	7
10.	NLS 1 and NLS 2 without STME out N_x event comparison versus X-station	7
11.	Overall NLS 1 and NLS 2 N_x line load comparison versus X-station.....	8
12.	NLS 1 and NLS 2 maximum composite shear versus X-station	8
13.	MLP locations for holddown pad loads.....	14
14.	NLS 2 core ascent engine out overall max V_{eq} versus X-station.....	15
15.	NLS 2 core ascent engine out overall max P_{eq} versus X-station.....	16
16.	NLS 2 core ascent overall maximum P_{eq} versus X-station	16
17.	NLS 2 core ascent overall maximum V_{eq} versus X-station	17
18.	NLS 1 core prelaunch cycle 1 and cycle 0 static N_x comparison versus X-station	17
19.	NLS 2 core prelaunch cycle 1 and cycle 0 static N_x comparison versus X-station	18
20.	NLS 1 core prelaunch cycle 1 and cycle 0 N_x comparison versus X-station.....	18
21.	NLS 2 core prelaunch cycle 1 and cycle 0 N_x comparison versus X-station.....	19
22.	NLS 2 core max-q cycle 1 and cycle 0 N_x comparison versus X-station	19

LIST OF ILLUSTRATIONS (Continued)

Figure	Title	Page
23.	NLS 1 core max-q cycle 1 and cycle 0 N_x comparison versus X-station	20
24.	Thrust structure model representation	22
25.	NLS 2 overall vehicle model	22
26.	CCS attach point locations and directions	26
27.	ASRB attach point locations and directions	33

LIST OF TABLES

Table	Title	Page
1.	NLS 1 maximum line loads N_x (lb/in)	9
2.	NLS 2 maximum line loads N_x (lb/in)	10
3.	NLS overall maximum line loads N_x (lb/in)	11
4.	NLS overall max/min shear loads (lb)	12
5.	NLS 1 interface loads summary	13
6.	NLS 2 interface loads summary	13
7.	ASRB to launch pad loads summary	14

DEFINITION OF SYMBOLS

ASRB	Advanced Solid Rocket Booster
ASRM	Advanced Solid Rocket Motor
CCS	Common Core Stage
CTV	Cargo Transfer Vehicle
FORMA	FORTRAN Matrix Analysis Computer Code
FPM	Forward Propulsion Module
FRF	Flight Readiness Firing
F_x	Force in the X-Direction
F_y	Force in the Y-Direction
F_z	Force in the Z-Direction
HLLV	Heavy Lift Launch Vehicle
KSC	Kennedy Space Center
K_v	Uncertainty factor
LH ₂	Liquid Hydrogen
lox	Liquid Oxygen
MLP	Mobile Launch Platform
M_y	Moment About Y-Axis
M_z	Moment About Z-Axis
NASTRAN	NASA Structural Analysis Finite Element Computer Code
NLS 1	National Launch System 100 klb Payload Launch Vehicle
NLS 2	National Launch System 50 klb Payload Launch Vehicle
NSTS	National Space Transportation System
N_x	Load in the X-Direction Per Inch of Vehicle Circumference
N_v	Combined Load in the Y-Z Plane Per Inch of Vehicle Circumference
P	Axial Load
P_{eq}	Total Axial Load, Including Moment Effects
Q	Dynamic Pressure
R	Radius
RSS	Root Sum Squared
SRB	Solid Rocket Booster
STME	Space Transportation Main Engine
STS	Space Transportation System
V	Y-Z Load
V_{eq}	Total Y-Z Load, Including the Effect of Torsion
VAB	Vehicle Assembly Building

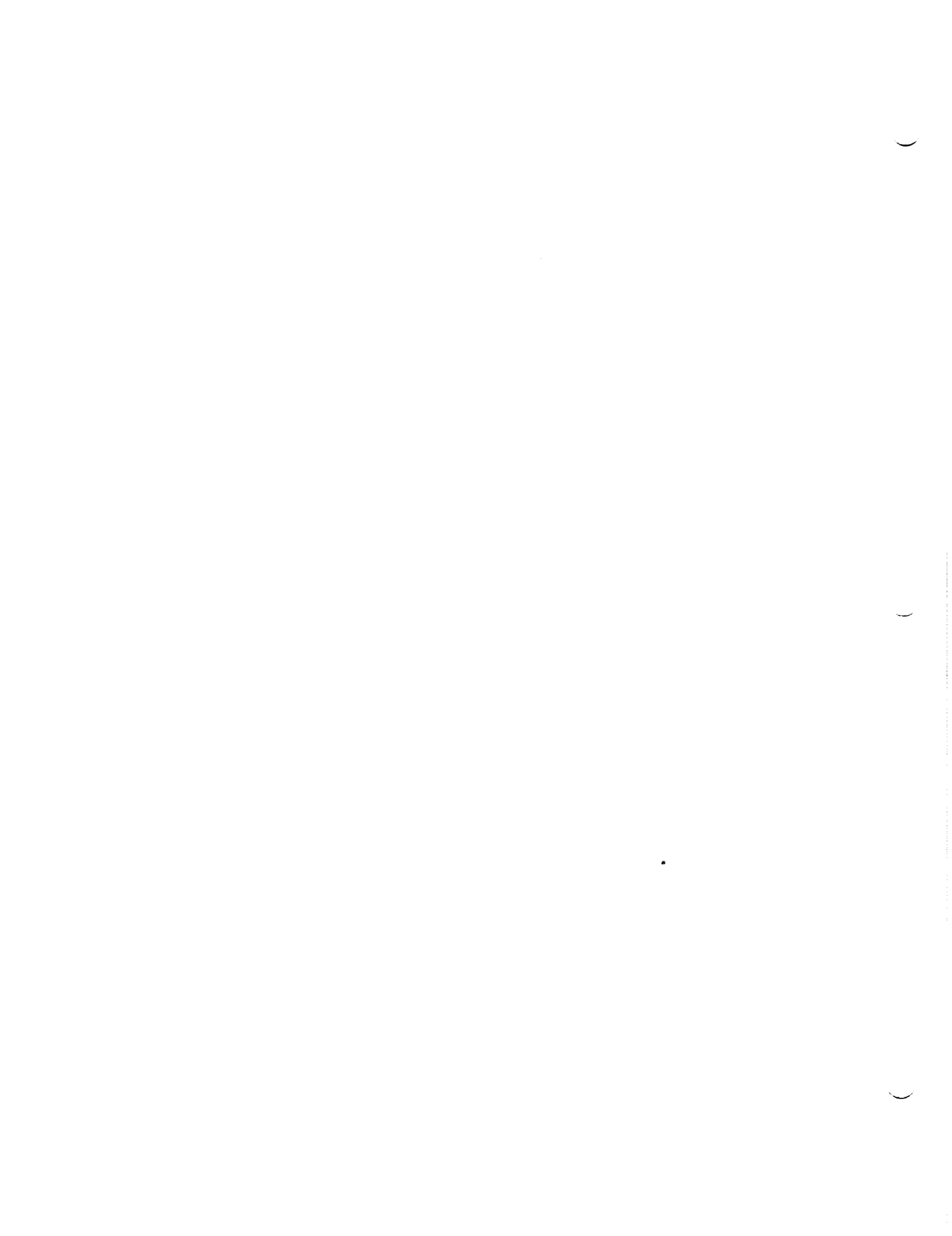

TECHNICAL MEMORANDUM

NATIONAL LAUNCH SYSTEM LOADS AND MODELS DATA BOOK

I. INTRODUCTION

The National Launch System (NLS) Reference Launch Vehicles Definition document was published in May 1991¹ and contained the basic design criteria and guidelines for a series of launch vehicles designated NLS 1 (heavy lift launch vehicle or HLLV) and NLS 2 (stage 1.5). The use of existing National Space Transportation System (NSTS) hardware, tooling, and methodology was emphasized as a means of minimizing the overall cost.

The design reference missions require that NLS 1 and NLS 2 launch vehicles be capable of placing nominal 100-kip (1 kip = 1,000 lb) and 50-kip payloads, respectively, in low-Earth orbit (LEO). The payloads may be composed of single or multiple payload elements. Both vehicles were to be capable of accomplishing their design reference missions with one liquid booster engine inoperative. In this study, it was assumed that the nominal vehicle was one which had all engines burning.

The NSTS advanced solid rocket boosters (ASRB's) with a lift-off thrust of approximately 3,350 kips thrust (sea level) and space transportation main engines (STME's) with a 580-kip vacuum thrust were selected as the basic propulsion systems for the two configurations. The NSTS external tank (ET) was defined to be the basis for modification to upgrade to a common core stage (CCS). The modifications were to be those required to permit the CCS to support a payload/payload shroud at the forward end of the liquid oxygen (lox) tank, a thrust structure, and up to six STME's positioned at the aft end of the liquid hydrogen (LH₂) tank.

The NLS 2 payload shroud was further defined to be a Titan IV derived structure to make use of currently available tooling.

The cargo transfer vehicle (CTV) is provided for additional orbital transfer capability for NLS 1 payloads. A forward propulsion module (FPM) would also be provided in conjunction with the CTV for final payload positioning.

A payload adapter would be provided for both configurations for mounting the payloads, and a transition section would provide a transition from the nominal 220-in payload shroud diameter to the 331-in CCS.

A modified NSTS mobile launch platform (MLP) or a platform constructed specifically for the NLS would be used to carry the launch vehicle from the vehicle assembly building (VAB) to the launch site.

Using the guidelines contained in reference 1, an analysis of the vehicle loads and dynamic response characteristics was performed. The ultimate use of the resulting data was to provide sufficient definition to the structural loading so as to facilitate detailed design of the overall structure during the next design cycle (cycle 2).

II. CONFIGURATION DESCRIPTIONS

The NLS 1 vehicle was composed of two ASRB's, CCS, CTV, FPM, payload shroud, payload adapter, transition section, and a nominal payload of 100 kips. The aft end of the CCS accommodates four liquid STME's rated at a nominal vacuum thrust level of 580 kips. The NLS 1 vehicle is propelled by the four liquid STME's and the two ASRB's. The NLS 1 vehicle was assumed to be constrained in three directions at each of eight holddown locations on the two ASRM's.

The NLS 2 vehicle was composed of the CCS, a Titan IV derived payload shroud, payload adapter, transition section, and a nominal payload of 50 kips. The NLS 2 vehicle is propelled by six STME's with four engines to be jettisoned in flight and two engines remaining to position the vehicle in the proper orbit. The launch vehicle was assumed to be constrained in three directions at each of four holddown locations at the base of the CCS thrust structure.

For purposes of interpreting the results of this analysis, a compressive load is defined as a positive value, and a tension load is defined by a negative value. An exception to this convention is the notation for the on-pad interface loads. When interpreting on-pad interface loads, a compressive load is defined as a negative value, and a tension load is defined as a positive value. All accelerations are shown in terms of absolute value. A diagram depicting the sign convention used in this analysis is shown in figure 1.

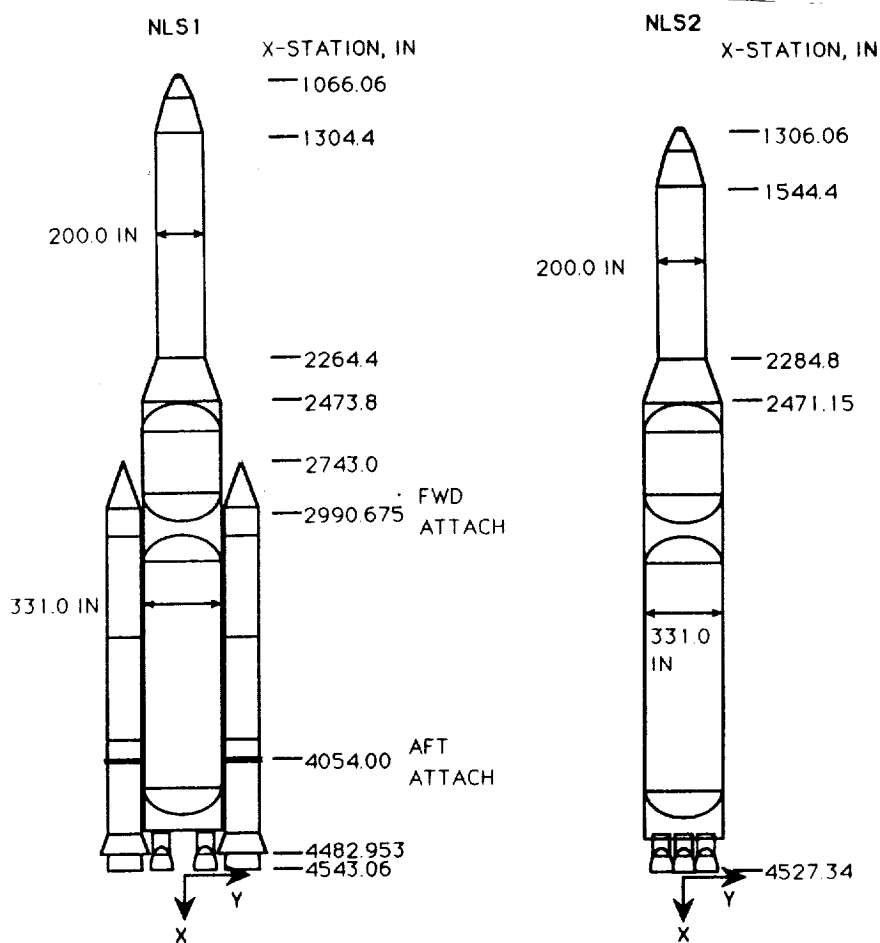

Figure 1. NLS 1 and NLS 2 reference vehicle.

III. COMMON CORE DESIGN LOADS SUMMARY

This section contains the recommended design loads for the CCS and shroud. In section A, the overall CCS line loads for both vehicles during all events are compared. Section B contains the overall maximum interface loads for the NLS 1 vehicle for all events. The shroud design loads are in section C. Finally, the cycle 1 line loads are compared to cycle 0 line loads in section D. It is recommended that the cycle 1 line loads in conjunction with the interface loads and transverse shears be used for the CCS design.

A. NLS 1 and NLS 2 Overall Line Loads

Comparisons of the prelaunch buildup and shutdown (BUSD) line loads, lift-off line loads, and ascent CCS line loads for both NLS 1 and NLS 2 vehicles were made. This was accomplished by superimposing plots of the line loads for the various conditions in figures 2 through 5. The data is plotted versus the X-station of the CCS. Several comparisons were made using the line load data, since the line load data were separated for nominal and engine out. Shown in figures 2 through 5 are the plots of the prelaunch and lift-off comparisons. NLS 1 maximum and minimum line loads during prelaunch events of buildup and shutdown envelope those of lift-off. This can be observed in figures 2 and 5. Similarly, figures 4 and 5 show that the highest line loads occur during the NLS 2 lift-off event.

The ascent line loads are added to prelaunch and lift-off line loads in figures 6 through 8 for both the nominal vehicle and engine-out condition. Note that the ascent analysis for the NLS 1 vehicle for STME out condition was not analyzed because the dominating thrust for the NLS 1 vehicle is produced by the ASRB's, and other engines (STME's) would be throttled up to 100-percent thrust for the engine out condition. Therefore, the "engine out" case is essentially the same as the "nominal" case for the NLS 1 ascent. The max-q ascent line loads envelope the prelaunch and lift-off line loads for all forward sections of the NLS 1 and NLS 2 vehicles. The lift-off line loads for the NLS 1 and NLS 2 vehicles envelope sections of the aft structure.

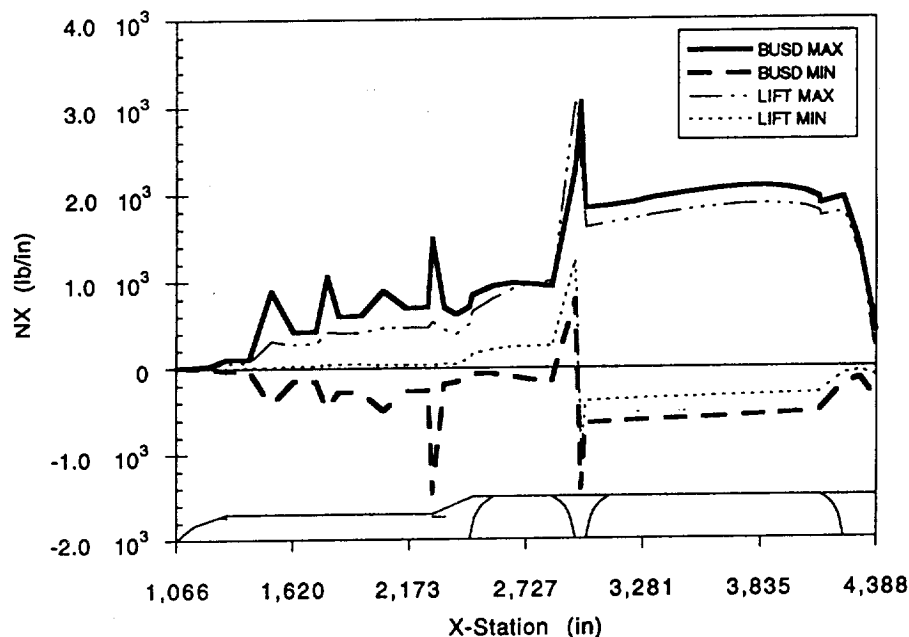

Figure 2. NLS 1 with STME out N_x max/min versus X-station.

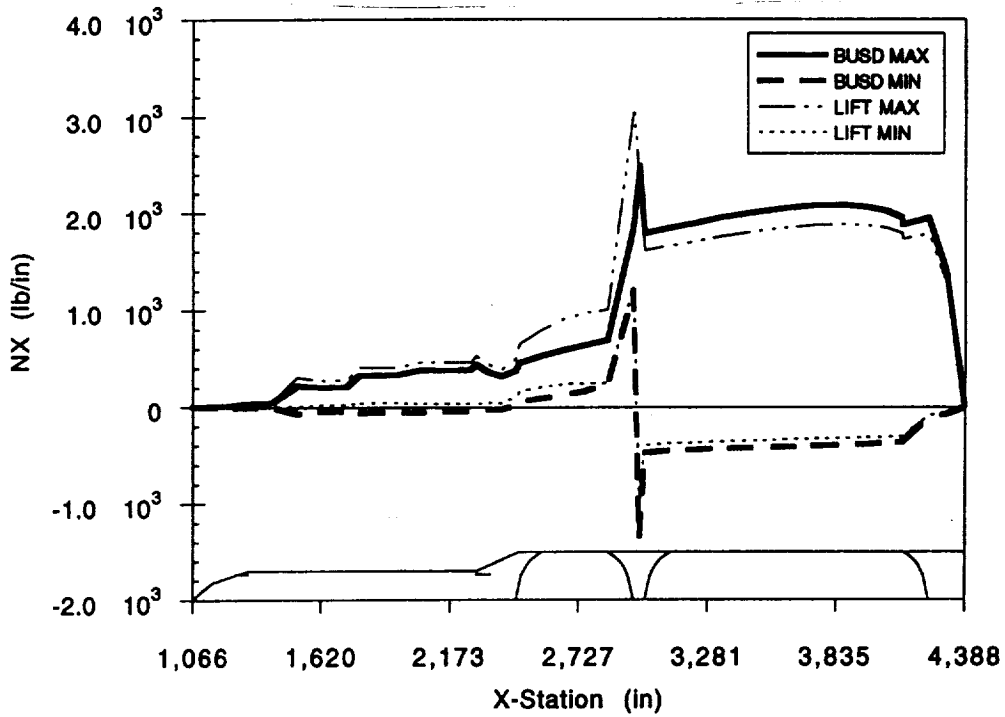

Figure 3. NLS 1 without STME out N_x max/min versus X-station.

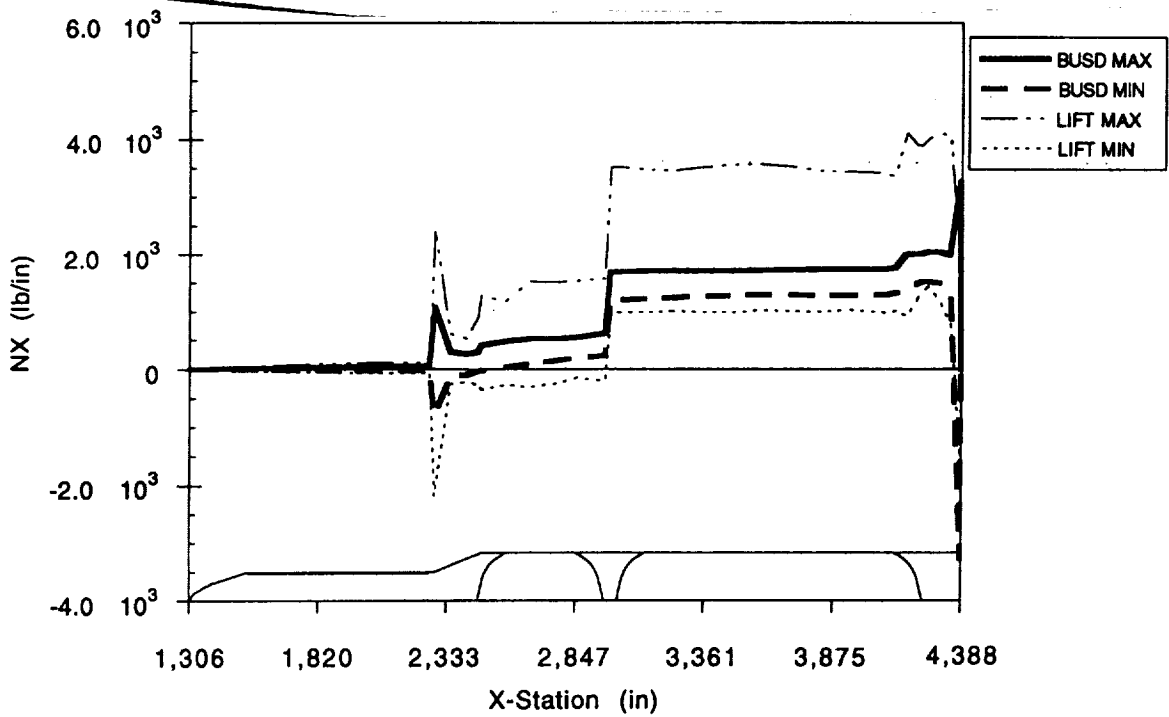

Figure 4. NLS 2 with STME out N_x max/min versus X-station.

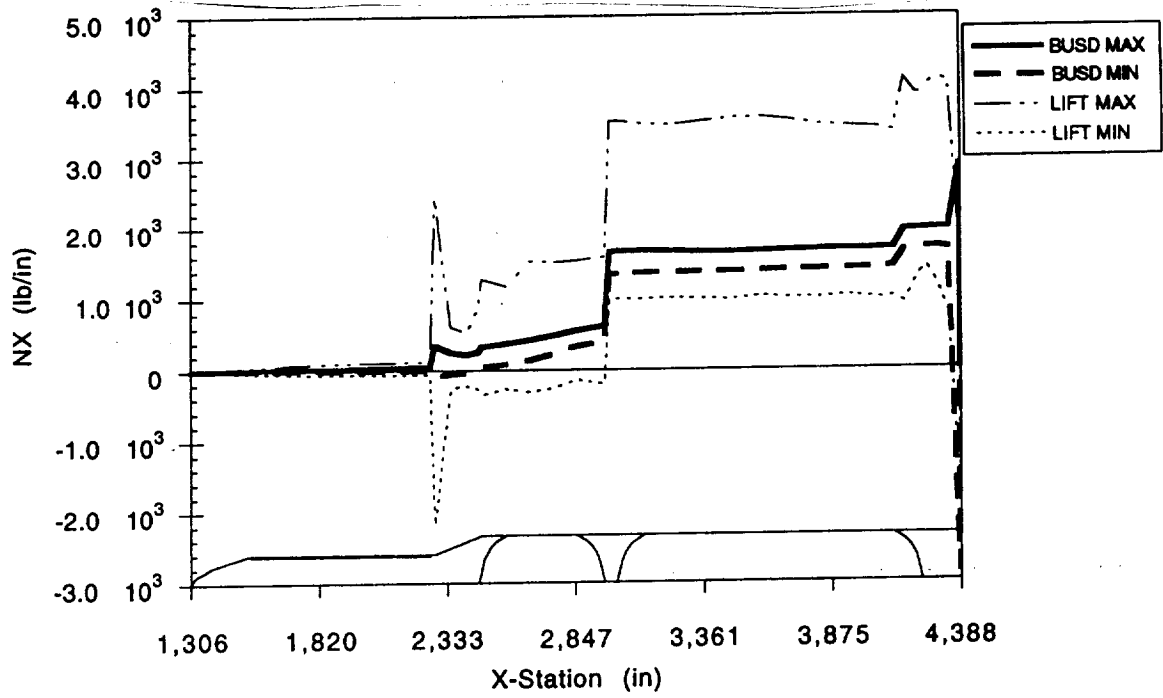

Figure 5. NLS 2 without STME out N_x max/min versus X-station.

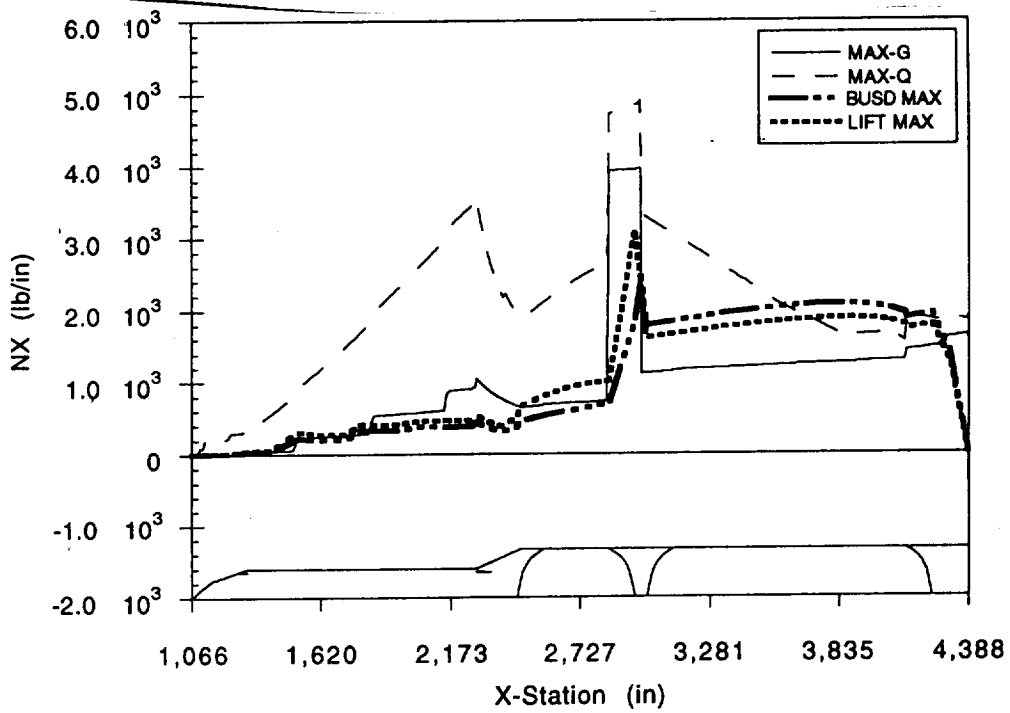

Figure 6. NLS 1 core without STME out N_x event comparison versus X-station.

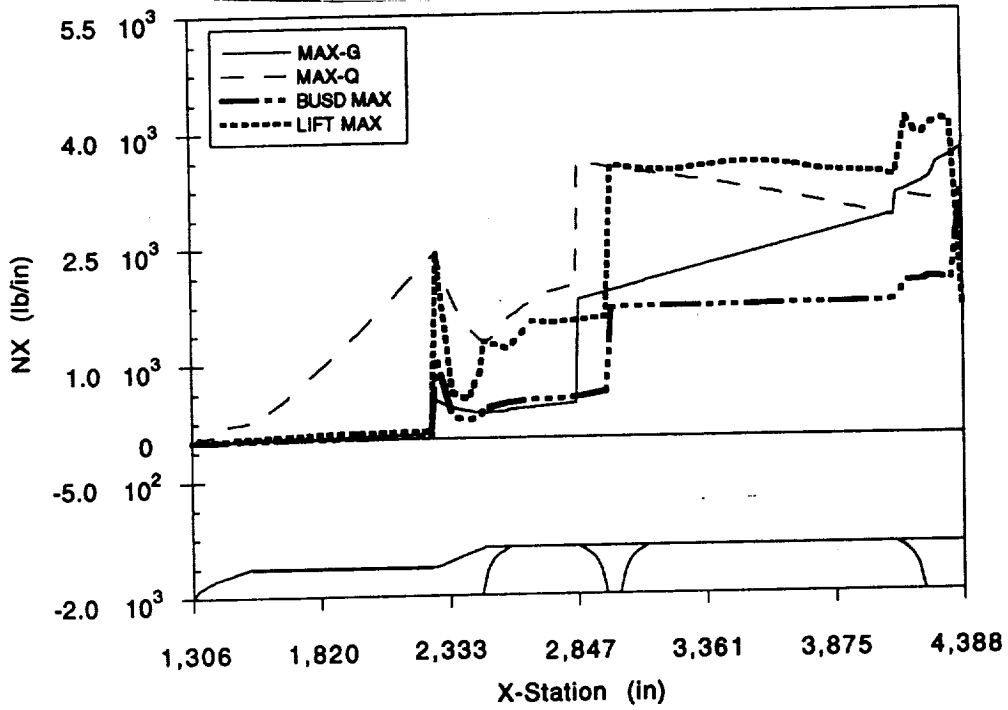

Figure 7. NLS 2 with STME out N_x event comparison versus X-station.

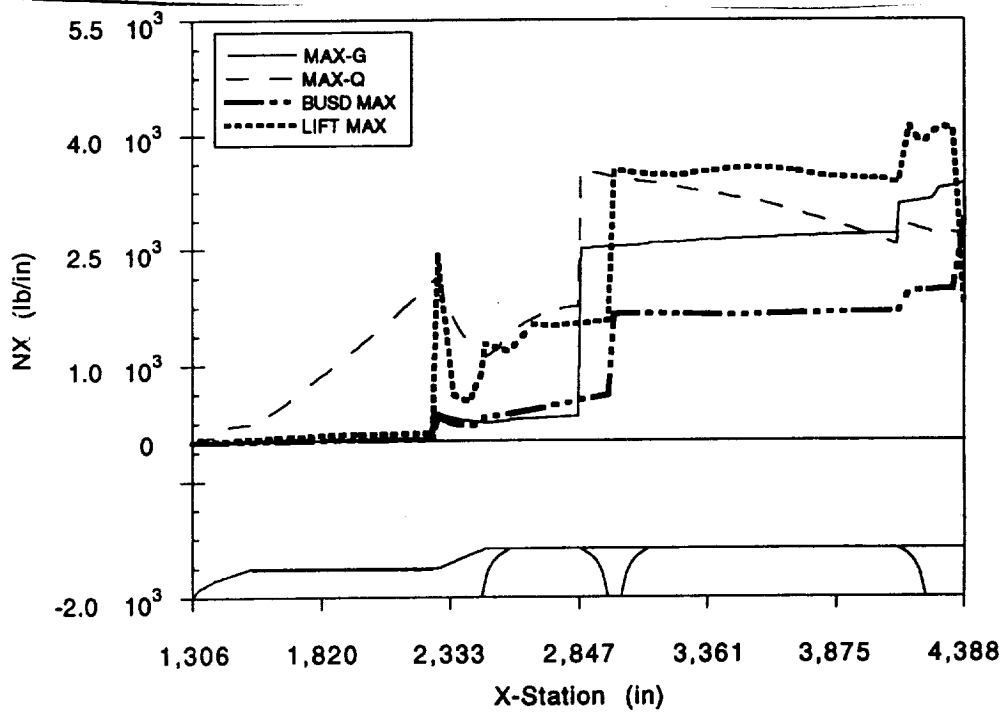

Figure 8. NLS 2 without STME out N_x event comparison versus X-station.

Next, the overall maximum line loads are plotted in figures 9 through 11. These values are tabulated in tables 1 through 3. The NLS 1 maximum line load values and the flight events which produced these maximums are given in table 1. NLS 2 maximum line load values are provided in table 2. The overall maximum line loads for both vehicles are tabulated in table 3 including the overall maximum design line loads for the CCS. This table further indicates the vehicle configuration and flight events corresponding to the maximum loading. Note that the NLS 1 vehicle "nominal" is the same as "engine out" for ascent flight events, therefore this condition was not analyzed. The CCS forward section has the highest line loads during max-q (NLS 1), while the CCS mid- to aft-section line loads are enveloped by lift-off and the static 180-day wind load case (NLS 2). The highest line load for the very aft section occurred during static 180-day wind load for the NLS 2 vehicle.

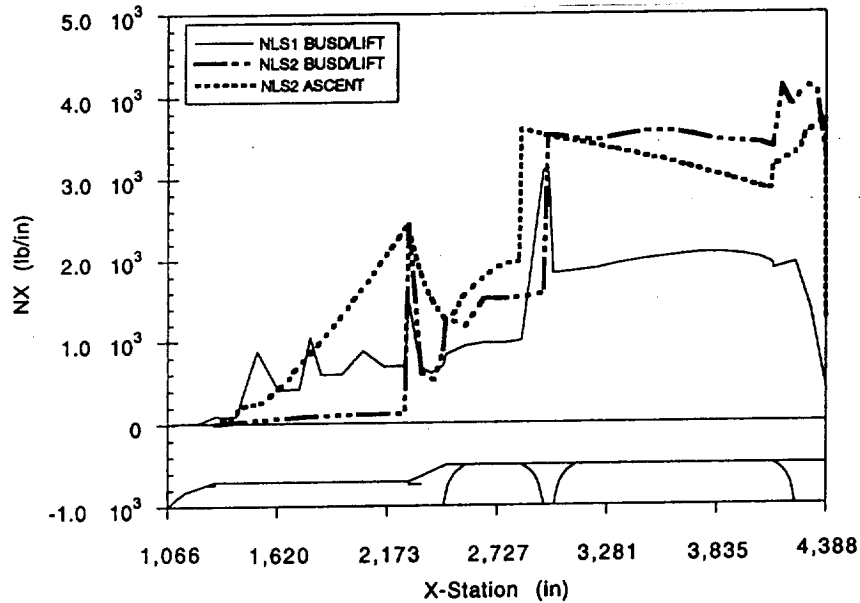

Figure 9. NLS 1 and NLS 2 with STME out N_x event comparison versus X-station.

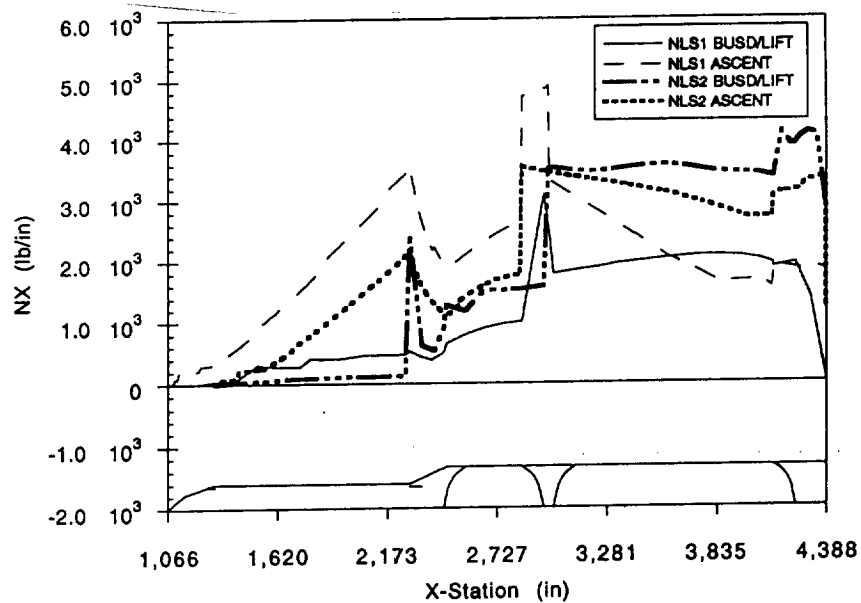

Figure 10. NLS 1 and NLS 2 without STME out N_x event comparison versus X-station.

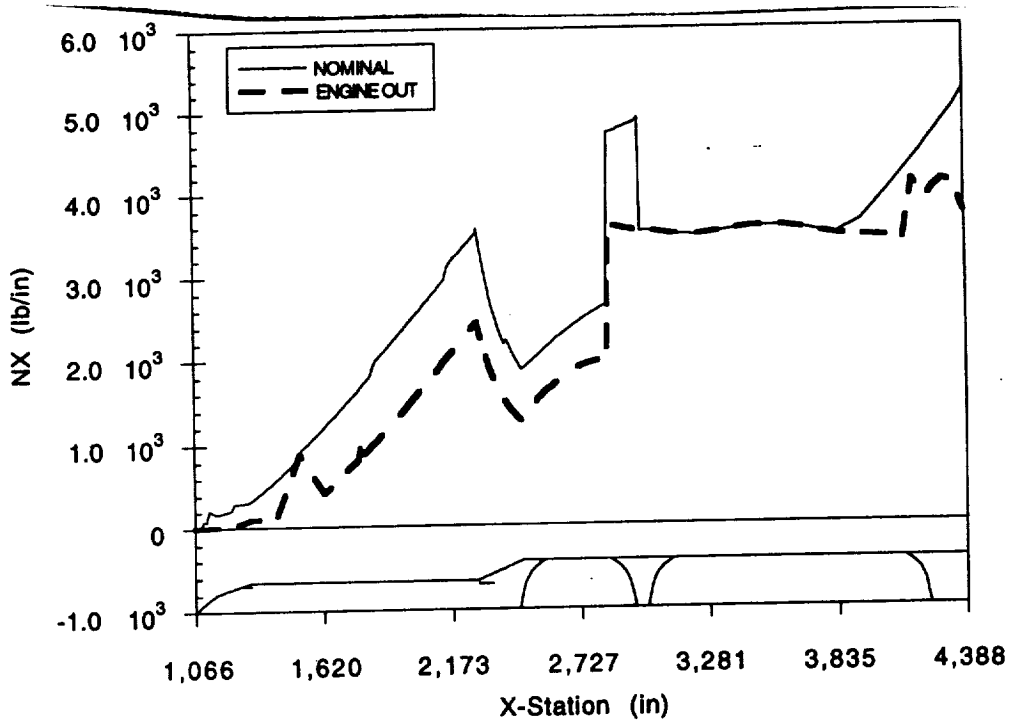

Figure 11. Overall NLS 1 and NLS 2 N_x line load comparison versus X-station.

The overall maximum and minimum design shear loads are provided in table 4 and are illustrated in figure 12.

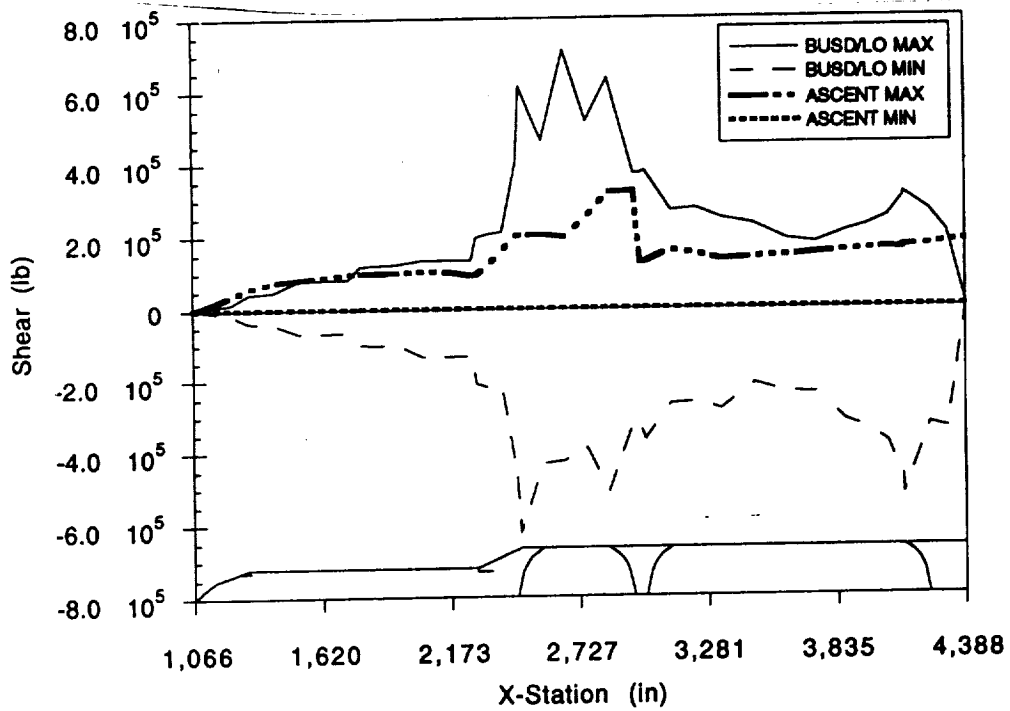

Figure 12. NLS 1 and NLS 2 maximum composite shear versus X-station.

Table 1. NLS 1 maximum line loads N_x (lb/in).

X-Station (in)	Max Value	Flight Condition
1,066.06	0	
1,110.6	84	MAX-Q
1,155.1	176	MAX-Q
1,229.75	292	MAX-Q
1,304.4	329	MAX-Q
1,411	578	MAX-Q
1,518	929	MAX-Q
1,625	1,120	MAX-Q
1,732	1,540	MAX-Q
1,784.4	1,700	MAX-Q
1,839	1,910	MAX-Q
1,946	2,290	MAX-Q
2,050.8	2,640	MAX-Q
2,160	3,100	MAX-Q
2,264.4	3,450	MAX-Q
2,284.8	3,570	MAX-Q
2,340.68	2,740	MAX-Q
2,396.57	2,180	MAX-Q
2,459.17	1,940	MAX-Q
2,473.8	1,870	MAX-Q
2,569.8	2,110	MAX-Q
2,664.13	2,320	MAX-Q
2,758.47	2,510	MAX-Q
2,852.8	4,730	MAX-Q
2,963.42	4,850	MAX-Q
2,990.67	3,320	MAX-Q
3,012.52	3,280	MAX-Q
3,123.15	3,050	MAX-Q
3,233.63	2,810	MAX-Q
3,337.35	2,600	MAX-Q
3,480.57	2,300	MAX-Q
3,623.8	2,046	BUILDUP/SHUTDOWN
3,747.4	2,073	BUILDUP/SHUTDOWN
3,871	2,077	BUILDUP/SHUTDOWN
3,964.5	2,058	BUILDUP/SHUTDOWN
4,054	2,014	BUILDUP/SHUTDOWN
4,118.65	1,944	BUILDUP/SHUTDOWN
4,122.65	1,910	MAX-Q
4,233.27	1,947	BUILDUP/SHUTDOWN
4,309.4	1,890	MAX-Q
4,385.5	1,900	MAX-Q

Table 2. NLS 2 maximum line loads N_x (lb/in).

X-Station (in)	Max Value	Flight Condition
1,306.1	0	
1,395.1	84.6	MAX-Q*
1,444.9	214	MAX-Q*
1,494.6	238	MAX-Q*
1,544.4	261	MAX-Q*
1,624.4	430	MAX-Q*
1,704.4	633	MAX-Q*
1,784.4	850	MAX-Q*
1,864.4	1,090	MAX-Q*
1,944.4	1,310	MAX-Q*
2,024.4	1,580	MAX-Q*
2,104.4	1,850	MAX-Q*
2,184.4	2,100	MAX-Q*
2,264.4	2,380	MAX-Q*
2,284.8	2,440	LIFT-OFF*
2,347.8	1,800	MAX-Q*
2,410.8	1,470	MAX-Q*
2,459.2	1,300	MAX-Q*
2,471.1	1,278	LIFT-OFF*
2,569.8	1,580	MAX-Q*
2,664.1	1,790	MAX-Q*
2,758.5	1,930	MAX-Q*
2,852.8	3,600	MAX-Q*
2,963.4	3,530	MAX-Q*
2,985.7	3,520	MAX-Q*
3,012.5	3,531	LIFT-OFF*
3,123.1	3,483	LIFT-OFF*
3,240	3,469	LIFT-OFF*
3,356.9	3,521	LIFT-OFF*
3,473.7	3,566	LIFT-OFF*
3,590.6	3,573	LIFT-OFF*
3,707.4	3,536	LIFT-OFF*
3,824.3	3,463	LIFT-OFF*
3,941.1	3,633.6	Static/180
4,058	3,995.2	Static/180
4,090.3	4,100.8	Static/180
4,122.6	4,207.6	Static/180
4,166.6	4,359.9	Static/180
4,210.3	4,514	Static/180
4,227.4	4,583.8	Static/180
4,254	4,683.2	Static/180
4,297.8	4,841.8	Static/180
4,341.6	5,002.7	Static/180
4,385.5	5,212.7	Static/180

* Engine out

Table 3. NLS overall maximum line loads N_x (lb/in).

X-Station (in)	Max Value	Vehicle	Flight Condition
1,066.1	0		
1,114.1	84	NLS 1	MAX-Q
1,155.1	176	NLS 1	MAX-Q
1,234.1	292	NLS 1	MAX-Q
1,304.4	329	NLS 1	MAX-Q
1,414.1	578	NLS 1	MAX-Q
1,522.1	929	NLS 1	MAX-Q
1,630.1	1,220	NLS 1	MAX-Q
1,738.1	1,540	NLS 1	MAX-Q
1,786.1	1,700	NLS 1	MAX-Q
1,834.1	1,910	NLS 1	MAX-Q
1,942.1	2,290	NLS 1	MAX-Q
2,050.1	2,640	NLS 1	MAX-Q
2,158.1	3,100	NLS 1	MAX-Q
2,264.4	3,450	NLS 1	MAX-Q
2,284.4	3,570	NLS 1	MAX-Q
2,338.1	2,740	NLS 1	MAX-Q
2,398.1	2,180	NLS 1	MAX-Q
2,459.4	1,940	NLS 1	MAX-Q
2,473.8	1,870	NLS 1	MAX-Q
2,569.8	2,110	NLS 1	MAX-Q
2,662.1	2,320	NLS 1	MAX-Q
2,758.1	2,510	NLS 1	MAX-Q
2,852.8	4,730	NLS 1	MAX-Q
2,963.2	4,850	NLS 1	MAX-Q
3,012.5	3,531	NLS 2	LIFT-OFF*
3,123.1	3,483	NLS 2	LIFT-OFF*
3,240	3,469	NLS 2	LIFT-OFF*
3,356.9	3,521	NLS 2	LIFT-OFF*
3,473.7	3,566	NLS 2	LIFT-OFF*
3,590.6	3,573	NLS 2	LIFT-OFF*
3,707.4	3,536	NLS 2	LIFT-OFF*
3,824.3	3,463	NLS 2	LIFT-OFF*
3,941.1	3,633.6	NLS 2	Static/180
4,058	3,995.2	NLS 2	Static/180
4,090.3	4,100.8	NLS 2	Static/180
4,122.6	4,207.6	NLS 2	Static/180
4,166.6	4,359.9	NLS 2	Static/180
4,210.3	4,514	NLS 2	Static/180
4,227.4	4,583.8	NLS 2	Static/180
4,254	4,683.2	NLS 2	Static/180
4,297.8	4,841.8	NLS 2	Static/180
4,341.6	5,002.7	NLS 2	Static/180
4,385.5	5,212.7	NLS 2	Static/180

* Engine out

Table 4. NLS overall max/min shear loads (lb).

X-Station (in)	Max Value	Vehicle	Flight Condition		X-Station (in)	Min Value	Vehicle	Flight Condition
1,066.06	384.8	NLS 1	MAX-Q	S H R O U D	1,066.06	-235.7	NLS 1	BUSD
1,110.6	7,490	NLS 1	MAX-Q		1,110.6	-3,069	NLS 1	BUSD
1,155.1	18,700	NLS 1	MAX-Q		1,155.1	-7,452	NLS 1	BUSD
1,229.75	37,800	NLS 1	MAX-Q		1,229.75	-3,540	NLS 1	BUSD
1,304.4	57,800	NLS 1	MAX-Q		1,304.4	-37,510	NLS 1	BUSD
1,411	75,700	NLS 1	MAX-Q		1,411	-40,660	NLS 1	BUSD
1,518	81,600	NLS 1	MAX-Q		1,518	-67,650	NLS 1	BUSD
1,625	88,300	NLS 1	MAX-Q		1,625	-67,660	NLS 1	BUSD
1,732	95,600	NLS 1	MAX-Q		1,732	-65,200	NLS 1	BUSD
1,784.4	116,700	NLS 1	BUSD		1,784.4	-99,170	NLS 1	BUSD
1,839	120,400	NLS 1	BUSD		1,839	-100,900	NLS 1	BUSD
1,946	122,500	NLS 1	BUSD		1,946	-100,300	NLS 1	BUSD
2,050.8	133,700	NLS 1	BUSD		2,050.8	-134,500	NLS 1	BUSD
2,160	133,700	NLS 1	BUSD		2,160	-134,500	NLS 1	BUSD
2,264.4	133,000	NLS 1	BUSD		2,264.4	-133,700	NLS 1	BUSD
2,284.8	195,300	NLS 2	LIFT-OFF		2,284.8	-211,100	NLS 2	LIFT-OFF
2,340.68	204,800	NLS 2	LIFT-OFF		2,340.68	-222,400	NLS 2	LIFT-OFF
2,396.57	209,400	NLS 2	LIFT-OFF		2,396.57	-228,000	NLS 2	LIFT-OFF
2,459.17	404,600	NLS 2	LIFT-OFF		2,459.17	-468,400	NLS 2	LIFT-OFF
2,473.8	612,500	NLS 2	LIFT-OFF		2,473.8	-625,100	NLS 2	LIFT-OFF
2,569.8	461,400	NLS 2	LIFT-OFF	2,569.8	-433,600	NLS 2	LIFT-OFF	
2,664.13	711,300	NLS 2	LIFT-OFF	2,664.13	-425,700	NLS 2	LIFT-OFF	
2,758.47	515,000	NLS 2	LIFT-OFF	2,758.47	-390,400	NLS 2	LIFT-OFF	
2,852.8	634,100	NLS 2	LIFT-OFF	2,852.8	-511,500	NLS 2	LIFT-OFF	
2,963.42	370,800	NLS 2	LIFT-OFF	2,963.42	-312,800	NLS 2	LIFT-OFF	
2,990.67	370,500	NLS 2	LIFT-OFF	2,990.67	-334,500	NLS 1	BUSD	
3,012.52	375,900	NLS 2	LIFT-OFF	3,012.52	-367,100	NLS 2	LIFT-OFF	
3,123.15	267,800	NLS 2	LIFT-OFF	3,123.15	-269,300	NLS 1	BUSD	
3,233.63	272,800	NLS 2	LIFT-OFF	3,233.63	-265,400	NLS 2	LIFT-OFF	
3,337.35	245,800	NLS 2	LIFT-OFF	3,337.35	-285,000	NLS 2	LIFT-OFF	
3,480.57	227,500	NLS 2	LIFT-OFF	3,480.57	-214,600	NLS 1	BUSD	
3,623.8	185,000	NLS 2	LIFT-OFF	3,623.8	-238,800	NLS 2	LIFT-OFF	
3,747.4	175,800	NLS 1	BUSD	3,747.4	-242,300	NLS 2	LIFT-OFF	
3,871	204,900	NLS 1	BUSD	3,871	-317,900	NLS 2	LIFT-OFF	
3,964.5	222,000	NLS 1	BUSD	3,964.5	-339,600	NLS 2	LIFT-OFF	
4,054	246,700	NLS 1	BUSD	4,054	-379,400	NLS 2	LIFT-OFF	
4,118.65	298,100	NLS 2	LIFT-OFF	4,118.65	-473,800	NLS 2	LIFT-OFF	
4,122.65	312,500	NLS 2	LIFT-OFF	4,122.65	-522,500	NLS 2	LIFT-OFF	
4,233.27	263,000	NLS 2	LIFT-OFF	4,233.27	-329,300	NLS 2	LIFT-OFF	
4,341.57	213,591	NLS 2	Static/180	4,309.4	-341,600	NLS 2	LIFT-OFF	
4,385.5	215,157	NLS 2	Static/180	4,385.5	-12,430	NLS 1	BUSD	

B. Interface Design Loads Summary

The overall maximum interface loads for the NLS 1 and NLS 2 vehicles are given in this section. Table 5 contains the overall maximum and minimum interface loads between the NLS 1 vehicle and the ASRB's. The locations and load directions for the interface loads and members are shown in figures 1 and 27. The NSTS limits are exceeded at the forward ASRB/CCS interface in the x and y directions and at the aft ASRB/CCS interface in the aft ASRB/CCS interface in the y direction. Table 6 contains the overall maximum and minimum interface loads between the NLS 2 and launch pad. These values along with the overall maximum line loads and overall max/min shear loadings comprise the CCS design loads.

Table 5. NLS 1 interface loads summary.

Member	Max Load (kips)	Min Load (kips)	NSTS Upper Limit	NSTS Lower Limit	Flight Condition
FTB1	59	-128	212	-190	Prelaunch
FTB2	64	-129	214	-206	Prelaunch
FTB3	211	-147	212	-95	Lift-off/Pre
FTB4	142	-229	86	-219	Pre/Lift-off
FTB5	419	-1,332	178	-1,672	Prelaunch
FTB6	254	-1,348	156	-1,672	Ascent/Pre
FTB7	85	-71	247	-233	Prelaunch
FTB8	80	-71	263	-224	Prelaunch
FTB9U	104	-113	295	-256	Pre/Lift-off
FTB10U	111	-102	277	-293	Lift-off/Pre
FTBA	121	-122	127	-267	Pre/Lift-off
FTBB	115	-126	277	-121	Lift-off/Pre
P(08)	66	-21	271	264	Ascent
P(09)	67	-24	358	-291	Ascent
P(10)	41	-38	233	-274	Ascent
P(11)	66	-21	265	-299	Ascent
P(12)	67	-24	296	-274	Ascent
P(13)	41	-38	244	-258	Ascent
MTBLS	9,235	-9,000	11,800	-11,800	Ascent
MTBRS	8,994	-9,238	11,800	-11,800	Ascent

Table 6. NLS 2 interface loads summary.

Pad Number	Max Load (kips)	Y-dir	Z-dir	Min Load (kips)	Y-dir	Z-dir
	X-dir			X-dir		
M1	320	95	30	-975	-65	-65
M2	709	68	21	-587	-81	-35
M3	718	38	21	-597	-65	-61
M4	284	46	59	-942	-44	-28

The overall maximum and minimum ASRB to launch pad loads are provided in table 7. These values should be checked against current ASRB aft skirt design. The pad locations are shown in figure 13.

Table 7. ASRB to launch pad loads summary.

Pad Number	Max Load (kips)			Min Loads (kips)		
	X-dir	Y-dir	Z-dir	X-dir	Y-dir	Z-dir
M1	1,243	219	190	-1,015	-301	-227
M2	1,452	394	304	-1,274	-261	-326
M3	237	124	207	-697	-92	-6
M4	894	135	317	-1,008	-163	-299
M5	1,243	300	189	-1,021	-221	-225
M6	1,453	265	212	-1,296	-394	-318
M7	490	91	213	-697	-124	-164
M8	181	163	307	-957	-96	-108

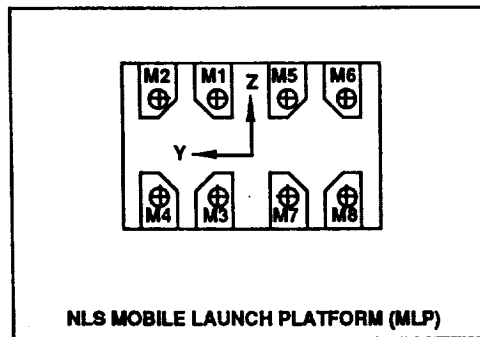

Figure 13. MLP locations for holddown pad loads.

The maximum LO₂ and LH₂ slosh mass accelerations were computed for both prelaunch (buildup and shutdown) and lift-off. From these values, a maximum aft bulk head pressure was computed using the ullage pressures of 20 lb/in² gauge for LO₂ and 32 lb/in² gauge for LH₂. The maximum aft bulk head pressures are:

Tank	Pressure	Vehicle	Event
LO ₂	54.0 lb/in ²	NLS 2	Prelaunch
LH ₂	49.3 lb/in ²	NLS 2	Lift-off

The overall payload accelerations for the NLS 1 and NLS 2 vehicles are provided in the tables below:

NLS 1 30/40/30K Payload Maximum Accelerations

Direction	Value (±G's)	Flight Condition
X	5.1	Buildup/Shutdown*
Y	2.3	Buildup/Shutdown*
Z	2.7	Buildup/Shutdown*

* Engine Out case

NLS 2 50K Payload Maximum Accelerations

<u>Direction</u>	<u>Value (\pmG's)</u>	<u>Flight Condition</u>
X	6.2	Lift-off
Y	3.2	Lift-off
Z	2.5	Lift-off

C. NLS 2 Modified Titan IV Shroud Design Loads

As may be noted from figures 14 through 17, the Titan IV shroud capability as expressed as both a P_{eq} and V_{eq} load was considerably exceeded. Titan IV shroud capability was taken from reference 19. A substantial reduction in $q-\alpha$ and/or $q-\beta$ is needed to maintain an adequate structural margin.

The $q-\alpha$ and $q-\beta$ terms are the products of dynamic pressure and angle-of-attack and dynamic pressure and angle-of-sideslip, respectively.

In order to understand the problems with the Titan IV shroud, the P_{eq} results were used to develop the shroud capability in terms of the maximum allowable $q-\alpha$ or $q-\beta$. The results showed that even with the use of a load relief control system, the nominal vehicle would exceed the allowable limits. It is therefore recommended that the shroud be structurally reinforced or redesigned to meet the ascent loads environment.

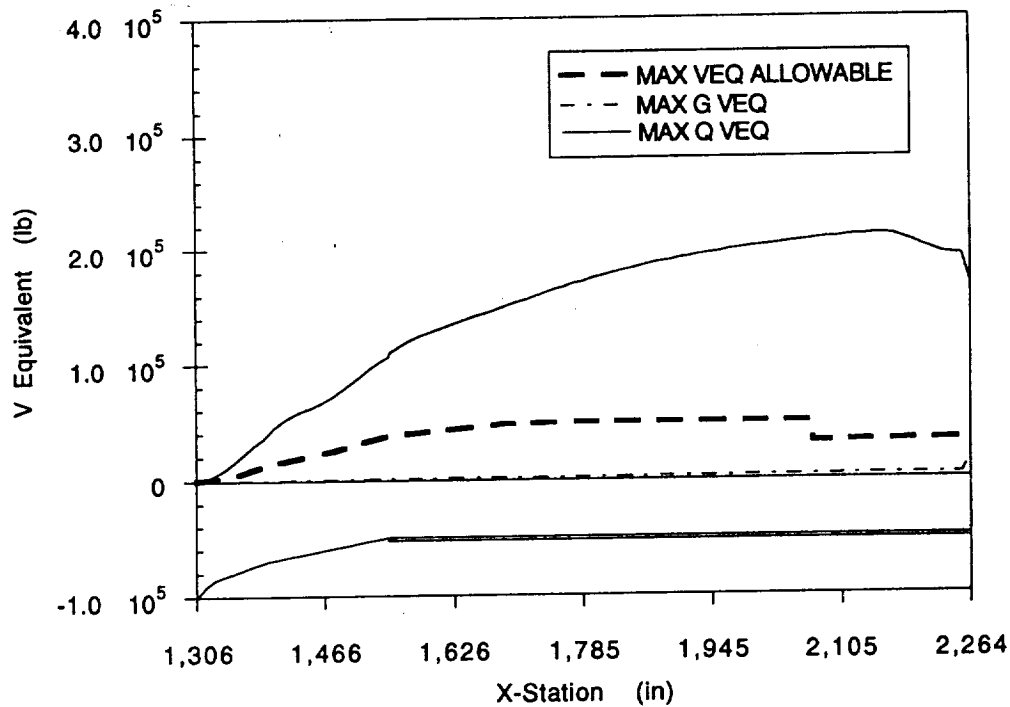

Figure 14. NLS 2 core ascent engine out overall max V_{eq} versus X-station.

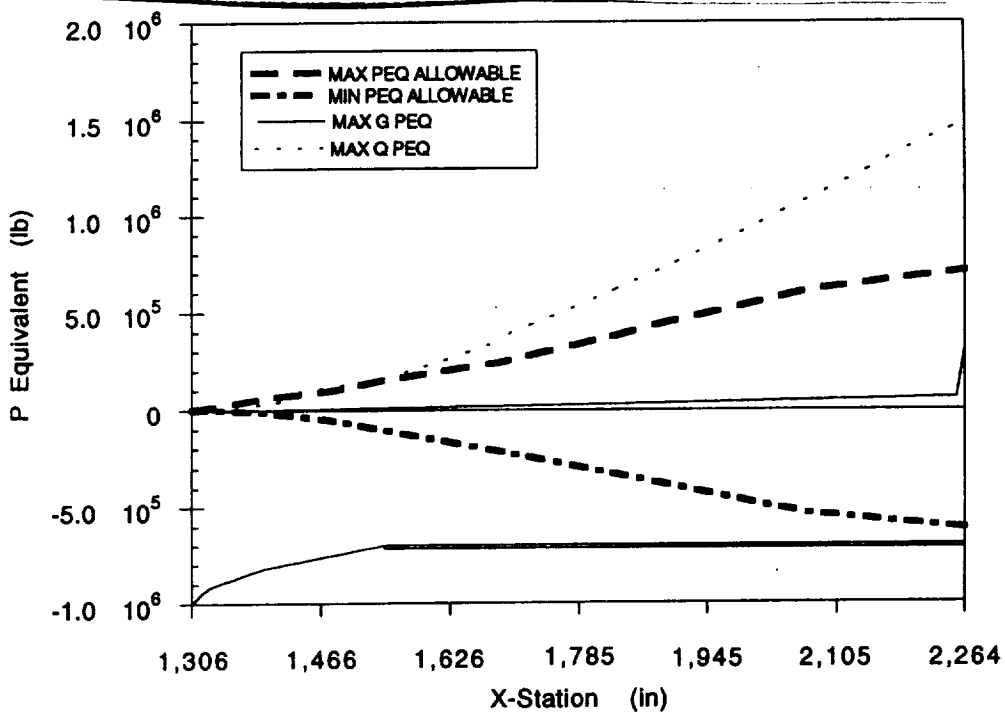

Figure 15. NLS 2 core ascent engine out overall max P_{eq} versus X-station.

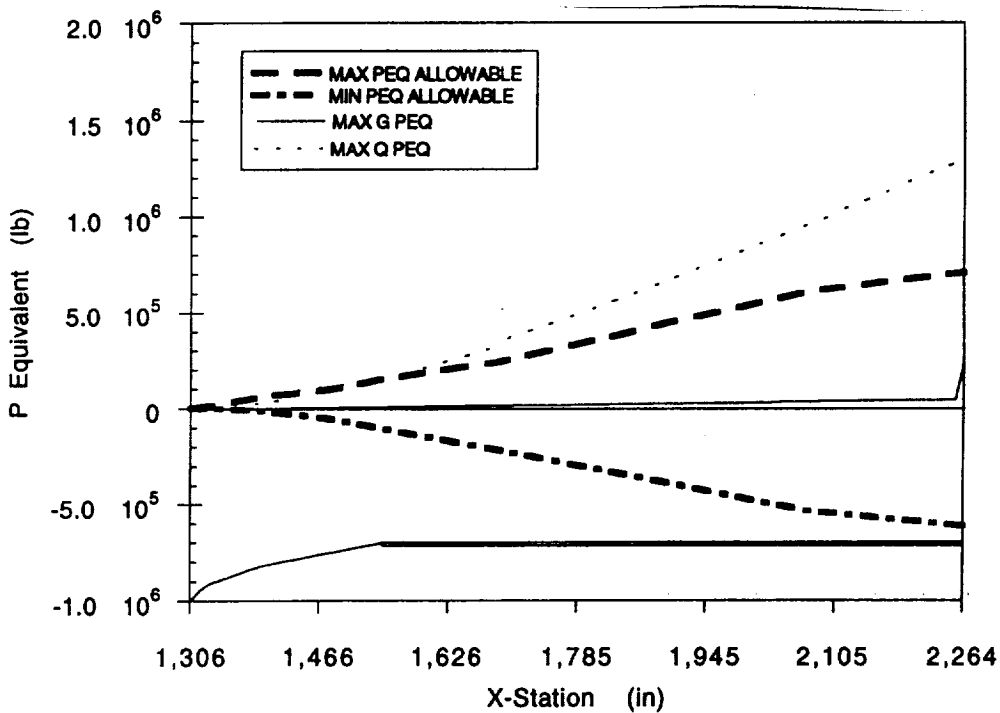

Figure 16. NLS 2 core ascent overall maximum P_{eq} versus X-station.

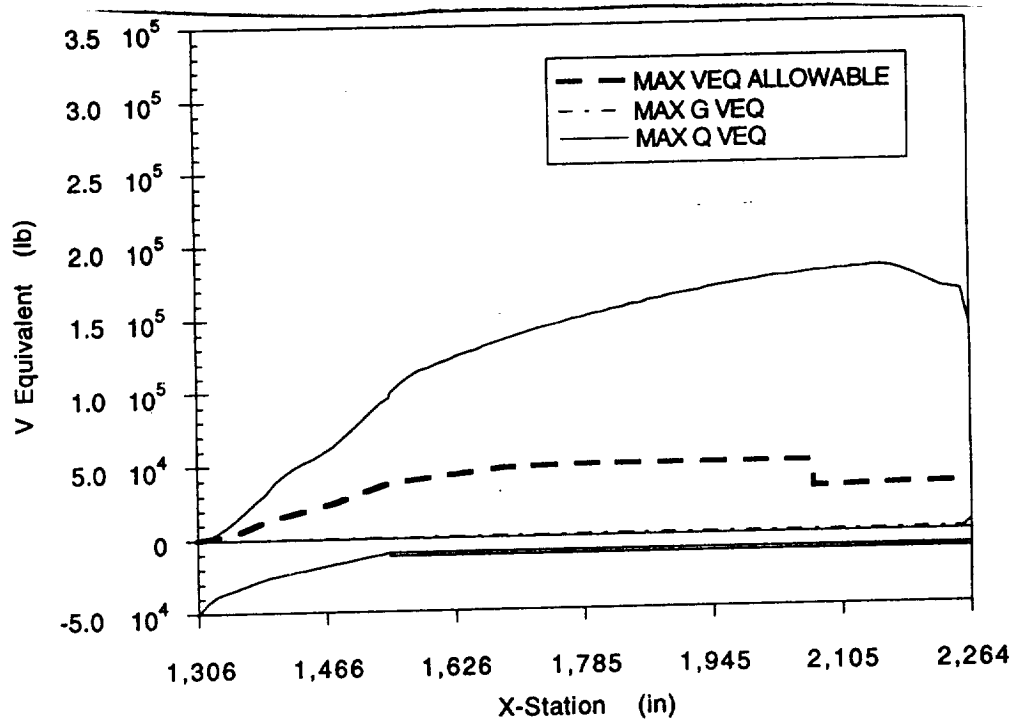

Figure 17. NLS 2 core ascent overall maximum V_{eq} versus X-station.

D. Comparison With Cycle 0 Baseline Loads

The cycle 1 results, obtained in this analysis, were compared to those results obtained in cycle 0 for like regimes of the NLS 1 and NLS 2 models. Figures 18 through 23 contain the comparisons between cycle 1 and cycle 0. The cycle 0 design case was rerun to eliminate tank pressures and is presented herein as a limit rather than ultimate load.

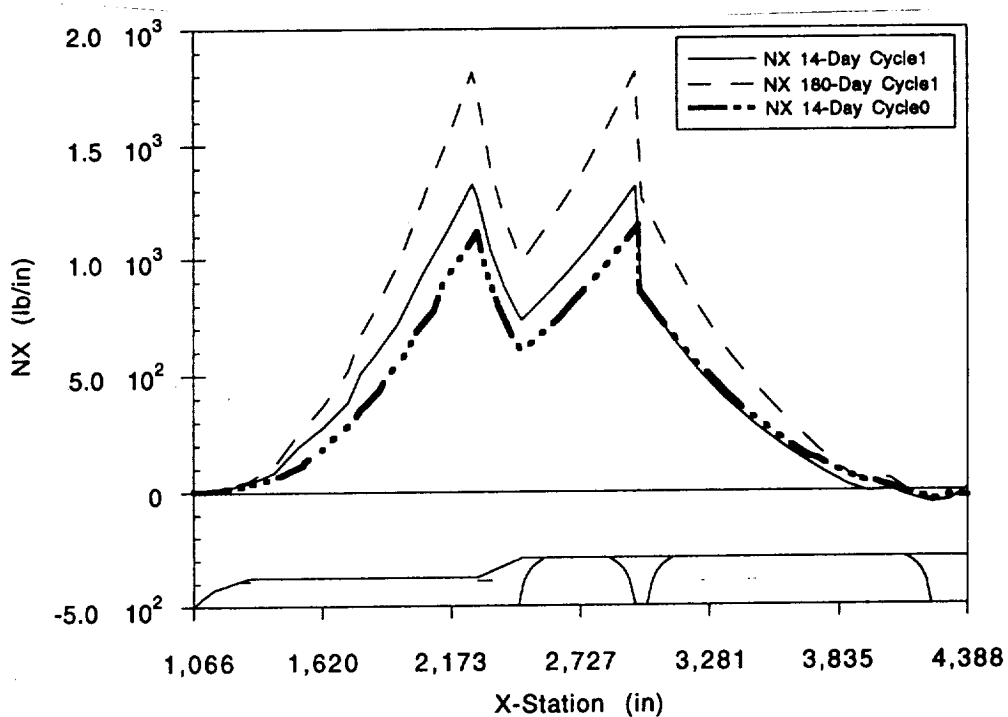

Figure 18. NLS 1 core prelaunch cycle 1 and cycle 0 static N_x comparison versus X-station.

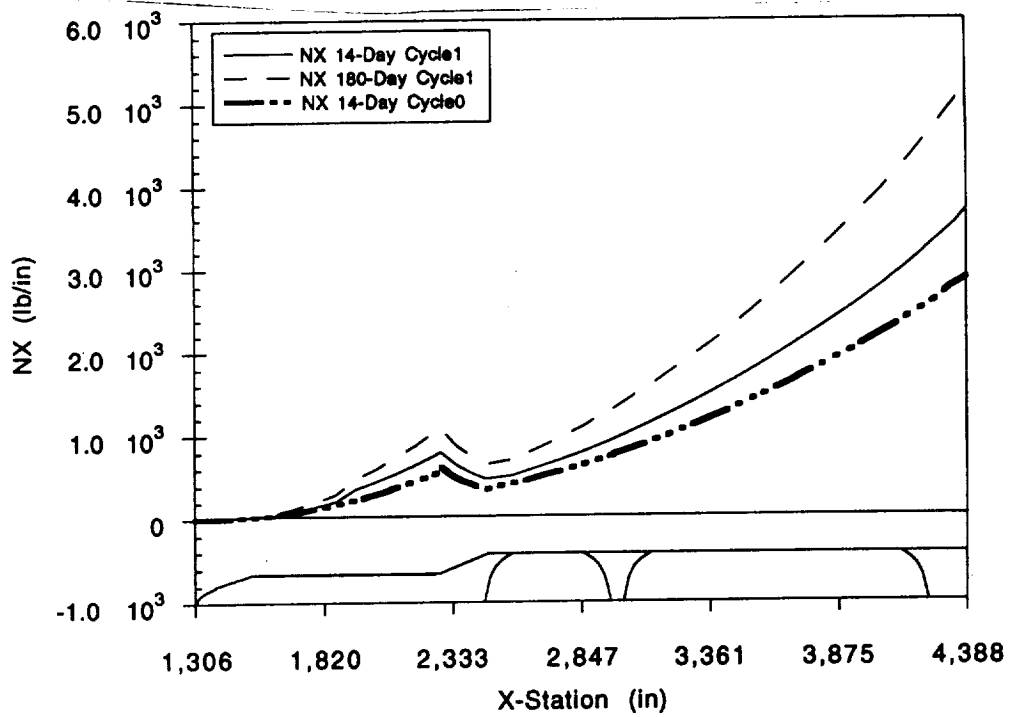

Figure 19. NLS 2 core prelaunch cycle 1 and cycle 0 static N_x comparison versus X-station.

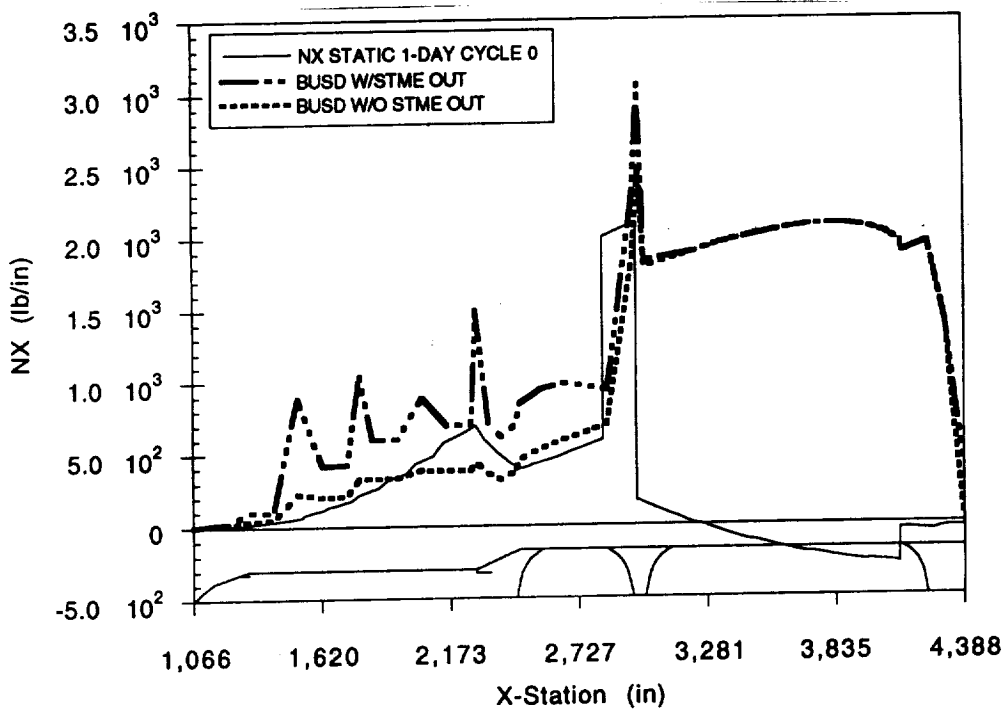

Figure 20. NLS 1 core prelaunch cycle 1 and cycle 0 N_x comparison versus X-station.

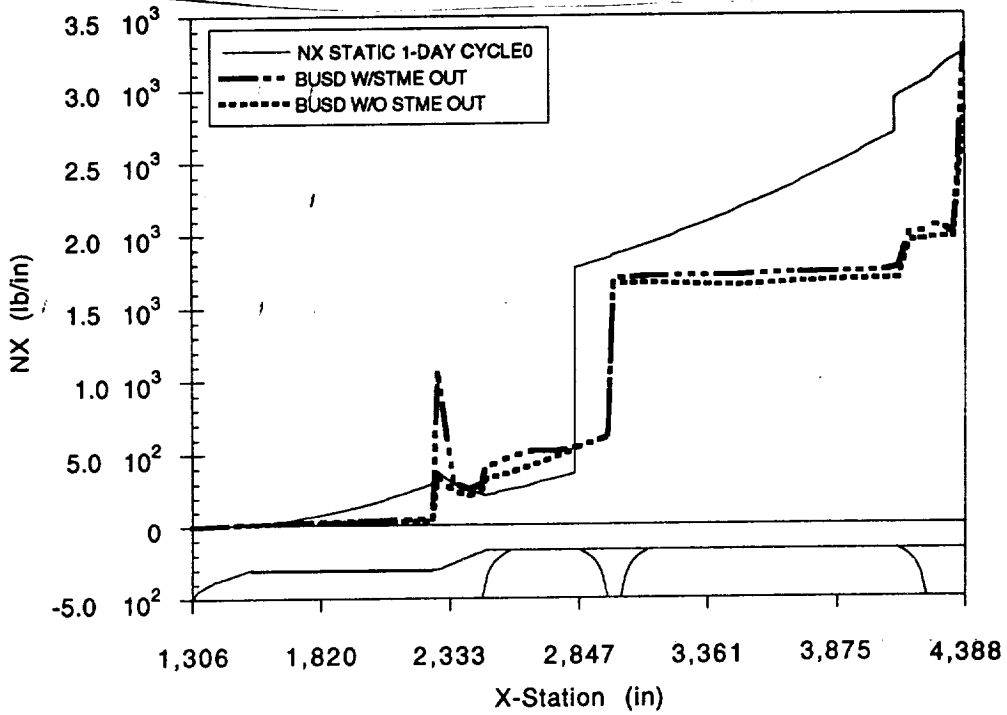

Figure 21. NLS 2 core prelaunch cycle 1 and cycle 0 N_x comparison versus X-station.

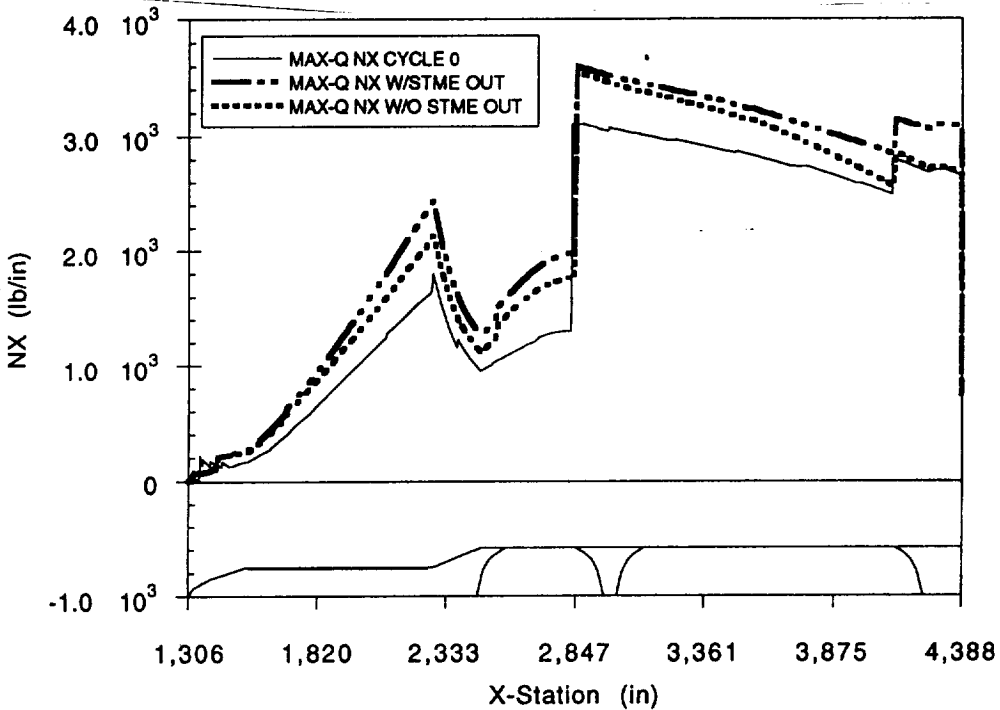

Figure 22. NLS core 2 max-q cycle 1 and cycle 0 N_x comparison versus X-station.

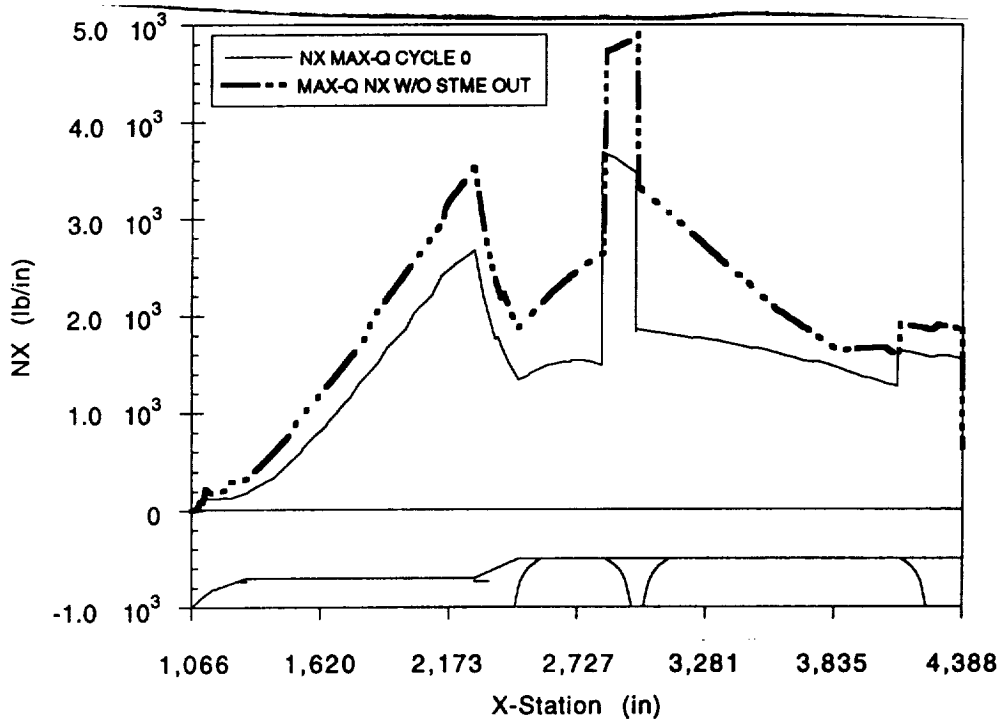

Figure 23. NLS 1 core max-q cycle 1 and cycle 0 N_x comparison versus X-station.

The following exceedances were noted for the max-q, buildup/shutdown, and prelaunch static regimes:

1. NLS 1 max-q results for cycle 1 runs envelope that of cycle 0 results.
2. NLS 1 prelaunch results from buildup and shutdown cases with engine out envelope those of cycle 0 except at the aft end of the LO₂ tank.
3. NLS 1 prelaunch static results for cycle 1 14-day winds envelope those of cycle 0 14-day winds for the LO₂ tank and above. The 180-day winds data obtained in cycle 1 exceed the other values throughout the entire vehicle.
4. NLS 2 max-q results for cycle 1 exceed those of cycle 0 throughout the vehicle except for the vehicle nose cap area.
5. NLS 2 prelaunch results for cycle 0 data exceed that of the cycle 1 except in an area extending from the payload adapter to the aft portion of the LO₂ tank.
6. NLS 2 prelaunch static results for 14-day winds show that cycle 1 exceeds those obtained in cycle 0 throughout the entire vehicle. The cycle 1 data for 180-day winds encompass both of these cases.

In general, the results obtained in cycle 1 encompass those from cycle 0. The exceedance noted for the NLS 1 model in cycle 0 is probably due to the lumping of the majority of the x-direction fuel weight at the bottom of the LO₂ tank for cycle 1 which shifted the cycle 1 results back. The only areas where cycle 0 exceeded those of cycle 1 were for the dynamic prelaunch cases in NLS 2 and a small area of exceedance in the nose cap area of the NLS 2 vehicle for the max-q results.

IV. STRUCTURAL DYNAMICS AND LOADS MODELS

A. Data Sources

1. Reference Configuration Drawings

The vehicle geometry of reference 1 was developed into detailed drawings and sketches of the NLS 1 and NLS 2 configurations in reference 2. All analyses herein are based on these vehicle locations. Figure 1 illustrates the NLS 1 and NLS 2 vehicle configurations.

2. Mass Properties

The NLS 1 and NLS 2 mass properties of reference 1 were incorporated in a set of detailed mass properties versus flight time for the NLS configurations in reference 4.

B. FORTRAN/NASTRAN Model Bulk Data

The NLS 1 and NLS 2 prelaunch and lift-off analyses were performed using various in-house developed finite element models and by also utilizing pre-existing finite element models. Ascent loads were developed utilizing a rigid-body approach with a combination of discrete and distributed aerodynamic and mass properties.

The prelaunch and lift-off finite element models were developed using NASTRAN and FORMA. The various models are as follows:

1. An in-house CCS vehicle flexible body (beam) model used for NLS 1 (HLLV) and NLS 2 (stage 1.5).
2. An NSTS mobile launch platform (MLP) flexible body model.
3. NSTS ASRB flexible body model used for boosters (nominal temperature only).

In order to accomplish the vehicle modeling and analysis in a minimum amount of time and to facilitate the start of the cycle 2 design stage, a number of assumptions and simplifications were made:

1. Lumped mass representation for payloads, FPM, and CTV.
 - (a) NLS 1 payload was assumed to be three lumped masses (two 30-klb masses and one 40-klb mass) rigidly mounted to the payload shroud with their c.g. at center of shroud.
 - (b) NLS 2 payload assumed a lumped mass rigidly mounted to payload adapter with the c.g. located at station X-1,997.58 inches.
2. NSTS external tank (ET) stiffness assumed for CCS.
3. Titan IV stiffness properties used for NLS 2 shroud flexible model.
4. NLS 1 ASRB/CCS vehicle interfaces assumed same as NSTS.

5. Slosh mass properties were approximated using single spring-mass systems to represent both the LO_2 and LH_2 fluid in the axial direction. The spring-mass systems were modeled using reference 18.

The NLS 2 model required that the thrust structure be modeled more accurately to appropriately represent the load paths in the vehicle. Reference 2 was used as a basis in modeling the thrust structure area. The thrust structure was tied into the stick vehicle model through rigid links. Figure 24 shows a close-up view of the thrust structure while figure 25 displays the overall representation of the NLS 2 vehicle.

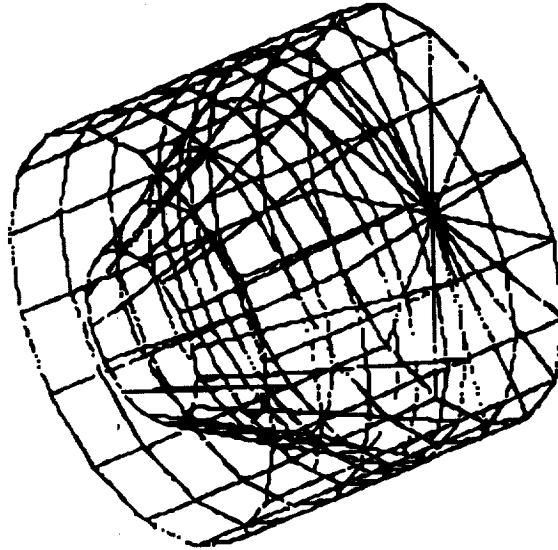

Figure 24. Thrust structure model representation.

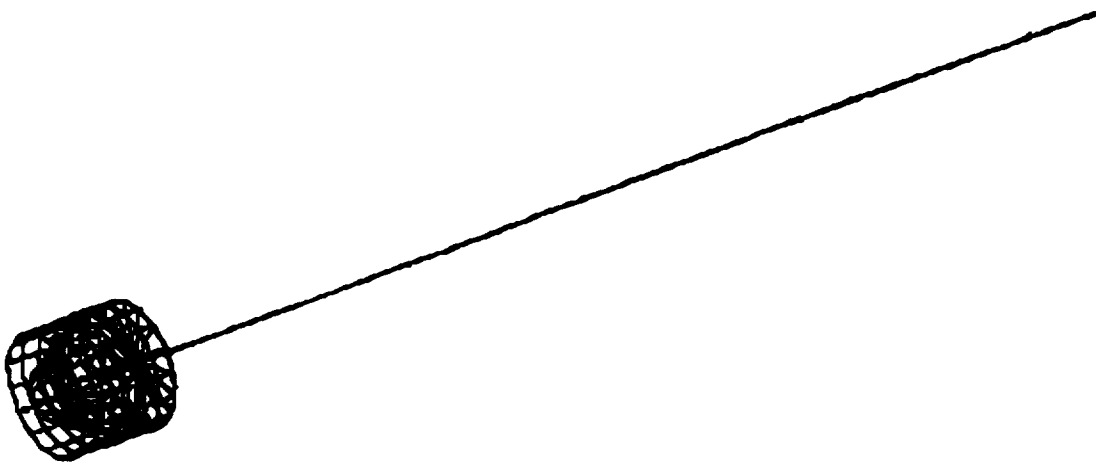

Figure 25. NLS 2 overall vehicle model.

Detailed mass properties are provided for the core stage in the appendix. Copies of the NASTRAN bulk data decks can also be found in the appendix.

C. Prelaunch and Lift-Off Model Modes and Frequencies

The mass and stiffness matrices for the prelaunch and lift-off configurations were reduced using standard reduction techniques and coupled together to give standard Craig-Bampton models.¹⁵ These models were then analyzed to determine the vehicle characteristics as a function of mode shapes and frequencies of the uncoupled system of equations.

The vehicle prelaunch and lift-off frequencies, respectively, for the predominant selected modes below a cutoff frequency of 20 Hz are provided in tabulated form in the appendix.

V. LOADING EVENTS

The prelaunch (on pad) and lift-off loading conditions were selected to include requirements defined and implied in reference 1. All conditions which were known or suspected to define limit loads were assessed in the various analyses. These analyses included ground wind loads for appropriate on-pad stay times defined by reference 1. The loading conditions analyzed are defined and developed in the following paragraphs.

A. On-Pad (Ground Winds, STME Buildup/Shutdown)

Prelaunch loads include ground winds for appropriate on-pad stay times. For a free-standing launch vehicle, the wind loading is the only forcing function acting on the vehicle other than gravity. Additional prelaunch cases include STME thrust buildup and shutdown in a simulated flight readiness firing (FRF) or on-pad abort and one STME engine out prior to launch commit resulting in an on-pad abort.

1. Methodology/Assumptions

The methodology used for prelaunch analysis was essentially the same as that used in the lift-off analysis with the exception of releasing the vehicle from the launch pad. The vehicle dynamic responses were computed by integrating the uncoupled equations of motion with the appropriate forcing functions. The resulting response time histories were then used in conjunction with appropriate load transformation equation matrices to provide the load time histories. Maximum and minimum values of the vehicle responses including loads and body accelerations were stored on magnetic disk for later processing. Reference 16 describes the methodology in more detail and will not be repeated here for brevity.

The following assumptions were made in the analysis:

1. Simultaneous ignition command to all STME's.
2. One STME engine-out analysis performed for worst engine at worst time.
3. Vehicle parameter dispersions were utilized in a 2- σ worst-on-worst combination.
4. An uncertainty factor K_v of 1.5 was applied to the dynamic response loads to account for the lack of design/model maturity.
5. Damping of all flexible body modes was assumed to be 1 percent of critical in the analyses.

2. Input Data Requirements and Sources

a. Ground Winds Criteria

All ground wind speeds were selected from reference 5 to satisfy the requirements of reference 1. The following wind speeds and corresponding probability levels were selected to meet the pad stay time requirements. All wind speeds were taken at the 99-percent probability level. The following wind criteria were selected to satisfy design requirements:

1. 180-day exposure—74.5 knot peak ground wind speed (unpressurized vehicle).
2. 14-day exposure—60.4 knot peak ground wind speed (unpressurized vehicle).
3. One-day exposure—47.0 knot peak ground wind speed (pressurized vehicle).

All wind speeds were referenced to the Kennedy Space Center (KSC) 60-foot pad light pole reference level. The wind loading was divided into two parts—the drag load and the vortex shedding load. The drag load was assumed to act parallel to the wind vector, and the vortex shedding was assumed to act normally to the wind vector. The wind loads were computed using a drag coefficient C_d of 1.0 for a simple cylinder (NLS 2) and a C_d of 1.5 for the multicylinder arrangement (NLS 1). An uncertainty factor of K_v of 1.5 was applied to the design wind loads to account for vortex shedding.

b. Forcing Functions/STME's

Forcing functions, which are the applied forces on the vehicles, were developed using the data provided in reference 14. Variations in the STME thrust profiles in conjunction with the ground winds provided the forcing functions used to assess the FRF and on-pad abort loads. A simultaneous ignition command was assumed applied to all STME's for the rebound analysis (FRF or on-pad abort). The STME thrust time history profiles are provided in the appendix. A total of 17 prelaunch forcing function cases for NLS 1 and 8 prelaunch forcing function cases for NLS 2 were developed using the STME thrust and applied wind data. Tables in the appendix give full details of each forcing function and which parameters were varied. These parameters include STME thrust levels, STME thrust misalignment, wind directions and speeds, and time of STME out conditions.

3. Loads Results for NLS 2

The NLS 2 vehicle was analyzed for prelaunch using the eight forcing functions listed in the appendix along with the static on-pad wind conditions listed in section 2.a. Results from the analyses include accelerations of the payload c.g. and the slosh masses of LO_2 and LH_2 . Shear and moment body loads of the NLS 2 vehicle were also recovered along with the vehicle line loads (N_x). The line load is defined as:

$$N_x = F_x / (2\pi R) \pm (M_y^2 + M_z^2)^{1/2} / (\pi R^2) \text{ (lb/in) ,}$$

where R is the radius of the vehicle, M_y and M_z are the moments of the vehicle, and F_x is the axial shear. Interface loads of the CCS to the pad were also computed.

a. Interface Loads/Accelerations

The NLS 2 holddown pad loads were computed for the CCS-to-pad interface. The composite maximum and minimum pad forces are tabulated and are given in the appendix. The largest values occur during the rebound of an abort condition with one STME out. The values for the maximum loaded hold-down location are:

$$F_x = -975 \text{ kips (compression)}$$

$$F_y = 95 \text{ kips}$$

$$F_z = 59 \text{ kips}$$

Composite maximum and minimum net c.g. accelerations for the 50-kips payload and the slosh masses of LO₂ and LH₂ were also computed and are tabulated in the appendix. Maximum acceleration values for the 50-kips payload occurred during rebound with an STME out condition. The maximum values are: 3.95 g's in the x direction and 0.9 g's in both the y and z directions. All tabulated composite results in the appendix are separated according to nominal and engine-out conditions.

b. Distributed Body Loads

The distributed body loads for NLS 2 CCS have been computed. The distributed body loads include the shear, moment, and line loads. Composite maximum and minimum values of the distributed loads are tabulated and plotted versus the NLS 2 CCS axial (X) stations in the appendix. The tables and plots of the distributed loads are for nominal and engine-out conditions. Distributed loads for on-pad static cases were also computed. These include the 180-day and 14-day winds. The distributed loads for these cases are tabulated and are given in the appendix.

The peak loads for the NLS 2 occur during the event of STME out and the static wind case with 180-day winds. For the on-pad conditions analyzed, the maximum distributed loads for the CCS are:

$$\text{max. shear} = 215.0 \text{ kips (180-day winds)}$$

$$\text{max. moment} = 302.4 \text{ million in-lb (180-day winds)}$$

These values occur at the station X-4,385.5, i.e., the base of the NLS 2 vehicle. Line loads for the NLS 2 vehicle are in the appendix in both tables and plotted versus X-station. The peak line load value for NLS 2 occurs at station X-4,385.5 and has a value of 3,276 lb/in. The line loads are recommended for the cycle 1 design.

4. Loads Results for NLS 1

The NLS 1 vehicle was analyzed for prelaunch using the 17 forcing functions listed in the appendix. Results from the analyses include net c.g. accelerations of the three payloads, the CTV, the FPM, and the slosh masses of LO₂ and LH₂. Distributed body loads of the CCS were also recovered which include axial and transverse shear, torsion, and moments. Line loads (N_x) for the CCS were also recovered. Line loads were computed as defined in section A.3. All results were computed nominal and engine-out conditions. Interface loads of the ASRB's to pad and ASRB's to CCS were also computed.

a. Interface Loads/Accelerations

Composite maximum and minimum interface loads of the ASRB to pad and ASRB to CCS are tabulated in the appendix. The interfaces are tabulated for nominal and engine-out conditions. The maximum holddown pad loads occurred during a rebound case with an STME out condition. Values for the maximum loaded aft skirt holddown location are:

$$F_x = -1,296 \text{ kips (compression)}$$

$$F_y = 264 \text{ kips}$$

$$F_z = 326 \text{ kips}$$

NLS 1 prelaunch composite maximum and minimum interface loads for the CCS to ASRB are tabulated in the appendix. Figure 26 illustrates the attach point locations and the interface load component directions. Some of the interface loads are higher than design values given for NSTS. NSTS design loads are exceeded in the x and y directions at the forward ASRB/CCS attach and in the y direction at the aft attach. Once again, the highest values occurred during a rebound case with STME out condition.

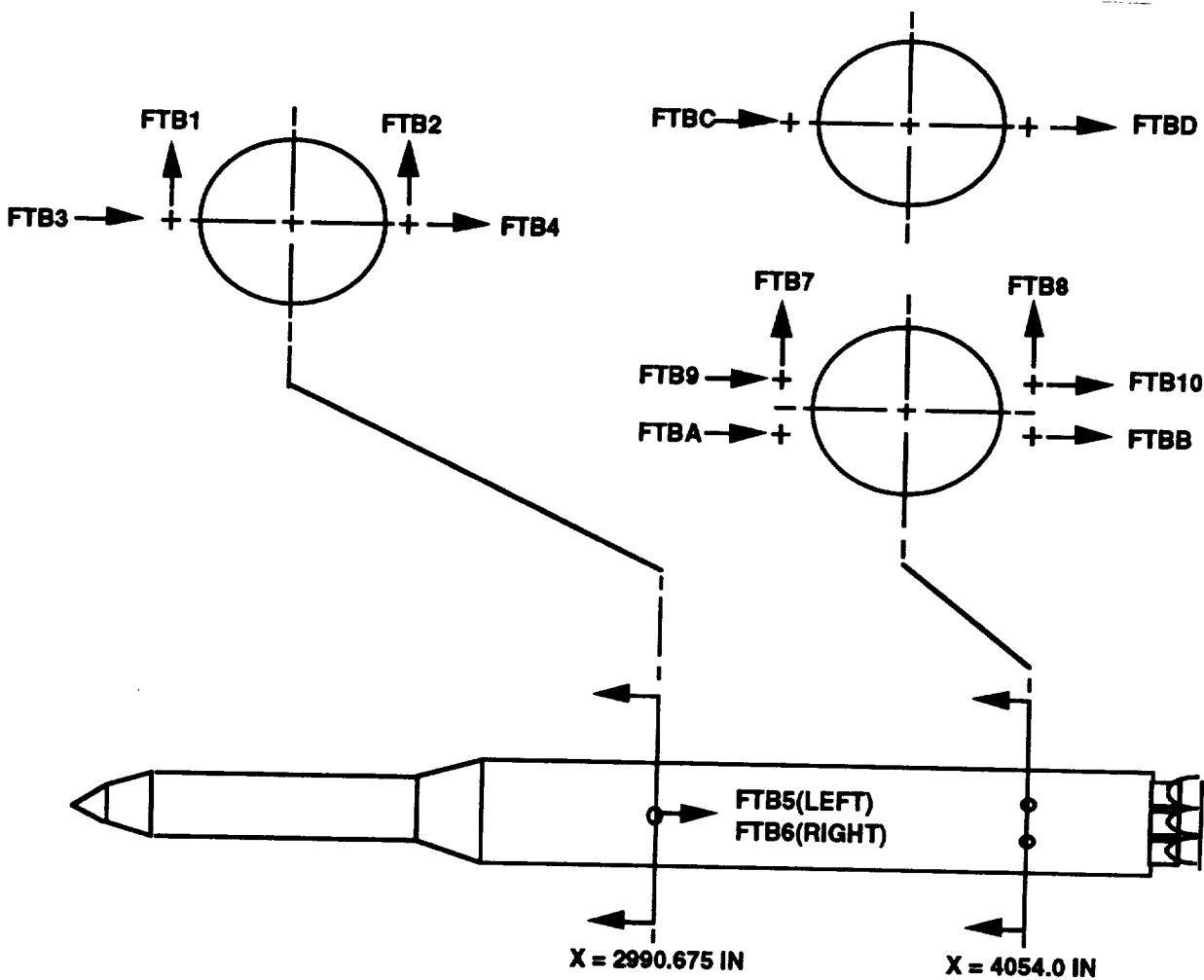

Figure 26. NLS 1 interface loads and directions.

The composite maximum and minimum net c.g. accelerations of the three payloads, along with the CTV, FPM, and slosh masses for LO₂ and LH₂, are provided in tabular form in the appendix. Of the three payloads, the forward 30-kip payload received the highest accelerations during a rebound condition with an STME out. Maximum accelerations for the CTV, FPM, and the forward payload were as follows:

	<u>X-dir</u>	<u>Y-dir</u>	<u>Z-dir</u>
CTV	3.8 g's	1.3 g's	1.8 g's
FPM	5.6 g's	4.7 g's	5.0 g's
30 k Payload	5.1 g's	1.7 g's	1.8 g's

b. Core Vehicle Distributed Body Loads

The distributed body loads for NLS 1 CCS have been computed. These include the axial and transverse shears, torsion and bending moments, and the line loads. Composite maximum and minimum values of the distributed loads are tabulated and plotted versus the NLS 1 CCS X-station in the appendix. The composites are separated according to nominal and engine-out conditions. The static shear and moment values for the CCS were also computed and are tabulated in the appendix. The peak distributed load for the NLS 1 vehicle occurs during a rebound condition with an STME out. The maximum transverse shear and moment recovered are:

Shear = 521 kips (z-dir, station X-2,473.8)
 Moment = 113 million in-lb (y-dir, station X-2,758.47).

Line loads for the NLS 1 vehicle are in the appendix in tables and plotted versus X-station. Peak line load values for NLS 1 occur at station X-2,990.67 and have the value of 3,056 lb/in. The line loads are recommended for the cycle 1 design.

5. On-Pad Prelaunch Loads Summary

The overall peak dynamic loads occur during the on-pad event of rebound (FRF) with an STME out abort condition. Only the NLS 2 vehicle has higher bending moments during the static 180-day wind load case (302.4 million in-lb). Some of the NLS 1 vehicle interface loads for the CCS to ASRB's were higher than NSTS allowables. The interface loads which are higher need to be considered for local interface design of the CCS. It is recommended that the N_x line loads be used for design of the CCS.

The NLS 1 vehicle experienced the highest payload accelerations of the on-pad conditions analyzed.

B. Lift-Off

In this section, the methodology and assumptions used to perform the lift-off analysis along with the forcing function cases that were derived will be described. Results from the analyses will be presented next, followed by a summary of the results for both NLS 1 and NLS 2 vehicles.

1. Methodology/Assumptions

A point-by-point release lift-off analysis was performed on both the NLS 1 and NLS 2 vehicles. The analysis used a power series approximation of the pad-to-vehicle interface forces. This allowed the equations of motion of the pad and vehicle to be solved separately with unknown coefficients at the end of each time step. The unknown coefficients were then obtained by enforcing the interface compatibility conditions between the two structures. Once the unknown coefficients were determined, the total response for that time step was computed. A check during each time step of the interface forces allows the analyst to simulate a point-by-point fly-away analysis by modifying the compatibility equations for those points that are released and go from a state of compression to tension. Reference 16 describes the methodology in more detail and, for brevity, will not be repeated here. The resulting response time histories were used in conjunction with appropriate load transformation equation matrices to provide the load time histories. Maximum and minimum values of the vehicle responses were stored on magnetic disk for later processing.

The following loading conditions were examined during the lift-off analysis:

1. STME thrust buildup.
2. One STME engine out.
3. Cryogenic loading (NLS 1).
4. ASRB thrust buildup.
5. ASRB overpressure loads.

The following assumptions were made in the analysis:

1. Simultaneous ignition command to all STME's.
2. Point-by-point fly-away from the MLP with no slow release mechanism.
3. Holddown bolts blown at 100-percent STME thrust level. Some cases were run with bolts blown at 90-percent thrust.
4. STME engine-out analysis performed for worst engine at worst time.
5. No vehicle flight control system (i.e., no engine gimbaling during lift-off transient).
6. Vehicle parameter dispersions were utilized in a 2- σ worst-on-worst combination.
7. An uncertainty factor K_v of 1.5 was applied to the dynamic response loads to account for the lack of design/model maturity.

2. Input Data Requirements and Sources

a. Ground Winds Criteria

The following conditions were examined in the lift-off analysis for the fully loaded vehicle with ground wind/wind shear and no gust.

1. One hour exposure, vehicle pressurized.
2. One STME engine out.

All ground wind-speed speeds were selected from reference 5 to satisfy the requirements of reference 1. The wind-speed speed for a 1-hour exposure time was 34.4 knots (peak) at the 95-percent probability level, as measured at the KSC 60-ft pad light pole reference level.

b. Forcing Functions

Forcing functions were developed using the data provided in references 12, 13, and 14. Variations in the applied thrust profiles (ASRB's and STME's) in conjunction with the ground winds provided the forcing functions used to assess the lift-off loads. A simultaneous ignition command was assumed applied to all STME's and ASRB's for the lift-off analysis. The STME thrust time history profiles are provided in the appendix. ASRB thrust and pressure profiles from reference 12 are also provided in the appendix. ASRB overpressure forces per model node number are plotted and given in the appendix (only applies to NLS 1).

A total of 17 lift-off forcing function cases for NLS 1 and 9 lift-off forcing function cases for NLS 2 were developed using the STME thrust, ASRB thrust/pressure (NLS 1), and applied wind data. Tables in the appendix give full details of each forcing function and which force parameters were varied. The parameters were varied $\pm 2\sigma$ with the various combinations. These parameters include:

1. ASRB ignition timing.
2. ASRB thrust rise rate.
3. ASRB thrust level.
4. ASRB ignition interval.
5. ASRB thrust mismatch.
6. ASRB ignition overpressure.
7. ASRB growth.
8. STME thrust levels.
9. STME thrust misalignment.
10. Ground wind directions.
11. Time of STME out conditions.
12. Cryogenic loading.

Cryogenic loading for the NLS 1 vehicle was included in the applied loading as statically applied forces superimposed at the CCS to ASRB interfaces.

3. Loads Results for NLS 2

The NLS 2 vehicle lift-off loads were assessed using the forcing functions described in section B.2.b. Results from the analyses include the payload c.g. accelerations and the LO₂ and LH₂ slosh mass accelerations. Vehicle shears and moments and interface loads of the CCS to the pad were also recovered. Line loads (N_x), as defined in section A.3, were also computed.

a. Interface Loads/Accelerations

The composite maximum and minimum interface loads for the CCS to pad interface are tabulated in the appendix. The peak values for one holddown location are:

$$F_x = -746.0 \text{ kips (compression)}$$

$$F_y = 65.3 \text{ kips}$$

$$F_z = 28.0 \text{ kips}$$

Composite maximum and minimum accelerations for the 50-kip payload and the slosh masses of LO₂ and LH₂ are also tabulated in the appendix. The peak values for the payload are as follows:

	X-dir	Y-dir	Z-dir
50 k Payload	±6.2 g's	±3.2 g's	±2.5 g's

All tabulated composite results in the appendix are separated according to with and without STME out conditions. There was no difference between the maximum payload accelerations for the nominal and STME out conditions.

b. Distributed Body Loads

The distributed body loads for CCS were computed and include shears, moments, and line loads. Composite maximum and minimum values of the distributed loads were tabulated and plotted versus the CCS X-station in the appendix. The tables and plots of the distributed loads are for the nominal and STME out conditions.

The peak distributed loads for NLS 2 are approximately the same for both the nominal and STME out events. The maximum distributed loads for the CCS were:

$$\text{Maximum shear} = 711 \text{ kips}$$

$$\text{Maximum moment} = 142 \text{ million in-lb.}$$

These values occur at the station X-4,385.5, i.e., the base of the NLS 2 vehicle. Vehicle line loads are contained in the appendix in both tabular and plotted form. The peak line load value occurred at station X-4,297.8 and had a value of 4,113 lb/in.

4. **Loads Results for NLS 1**

The NLS 1 vehicle was analyzed for lift-off using the forcing functions described in section B.2.b. Results from the analyses include net c.g. accelerations of the three payloads, the CTV, the FPM, and the slosh masses of LO₂ and LH₂. Distributed body loads of the CCS were also recovered including axial and transverse shears, torsion, and moments. Line loads (N_x) for the CCS were also recovered. Line load computation is defined in section A.3. All results were computed for the nominal and STME out conditions. Interface loads of the ASRB's to pad and ASRB's to CCS were also computed. Only one STME out condition was assessed in this analysis cycle due to time constraints.

a. Interface Loads/Accelerations

Composite maximum and minimum interface loads of the ASRB to pad and ASRB to CCS are tabulated in the appendix. The interface loads are tabulated for both the nominal and STME out conditions. Because only one STME out condition was analyzed, the composite maximum and minimum holddown pad loads are essentially the same as those for the nominal case. Values for the maximum loaded aft skirt holddown location are:

$$F_x = -833.3 \text{ kips (compression)}$$

$$F_y = 127 \text{ kips}$$

$$F_z = 277 \text{ kips.}$$

NLS 1 lift-off composite maximum and minimum interface loads for the CCS to ASRB are tabulated in the appendix. Some of the interface loads are higher than design values given for NSTS. NSTS design loads are exceeded in the x and y directions at the forward ASRB/CCS attachment and in the y direction at the aft attach. Once again, the highest values occurred during the nominal and the STME out conditions.

The composite maximum and minimum net c.g. accelerations of the three payloads, along with the CTV, FPM, and LO₂ and LH₂ slosh masses, are provided in tabular form in the appendix. Of the three payloads, the forward 30-kip payload experienced the highest accelerations. The maximum accelerations of the CTV, FPM, and the forward payload were:

	<u>X-dir</u>	<u>Y-dir</u>	<u>Z-dir</u>
CTV	±1.9 g's	±0.2 g's	±0.4 g's
FPM	±1.9 g's	±1.4 g's	±1.4 g's
30 k Payload	±1.8 g's	±0.9 g's	±0.93 g's

b. Core Vehicle Distributed Body Loads

The distributed body loads for the NLS 1 CCS were computed and include the axial and transverse shears, torsion and bending moments, as well as the line loads. Composite maximum and minimum values of the distributed loads are tabulated and plotted versus the CCS X-station in the appendix. The composite loads were presented separately for the nominal and STME out conditions.

Line loads for the NLS 1 vehicle are given in the appendix in tables and are plotted versus X-station. The peak line load value of 3,096 lb/in occurred at station X-2,963.42.

5. Lift-Off Loads Summary

The NLS 2 vehicle results exhibited the largest CCS distributed body loads. The shear, moment, and line body loads were all higher than those contained in the NLS 1 data. No significant differences were observed for the NLS 1 vehicle loads between the nominal and STME out conditions since only one STME out condition was analyzed. It is assumed that analysis of additional STME out cases would likely result in higher body and interface loadings for the NLS 1 vehicle.

The NLS 2 vehicle experienced the maximum payload accelerations as seen from the results.

C. Ascent

1. Methodology/Assumptions

The ascent loads environment was assessed using the squatcheloid approach and a rigid-body model. The time histories of vehicle wind responses were generated by applying the wind shear and gust to the wind envelope at the altitude of interest. The vehicle responses to the design winds were generated by the controls group at discrete altitude intervals (i.e., 8, 10, or 12 km) and at 12 clockwise intervals. The resulting responses were assessed at the point of maximum aerodynamic loading.

The point of maximum aerodynamic loading was determined from experience to be the point at which the RSS value of q -alpha and q -beta were at a relative maximum or minimum. Q -alpha (q - α) is the dynamic pressure (q) and angle-of-attack (α) product and q -beta (q - β) is the dynamic pressure and angle-of-sideslip (β) product. Summary tables of the q , q - α , q - β , Mach number, altitude, and translational and rotational accelerations were generated by the controls group for each altitude region.

The resulting data for each point in the table were plotted as q - α versus q - β , and the resulting figure is approximately elliptical and is called a squatcheloid (i.e., a squashed ellipsoid). Each point on the squatcheloid represents the maximum loading due to a head, tail, quartering, etc., wind at the discrete altitude (or Mach number) being examined. An incremental value q - α/q - β of 500 lb/ft² was added proportionately to all squatcheloids to account for parameter effects on the control trajectories.

Time consistent loads were then computed for each squatcheloid using a combination of discrete and distributed airloads acting on the body. For all squatcheloid cases, a detailed assessment of core vehicle loads was performed to include normal and axial shears, moments, line loads, and P -equivalent loads. Loads were developed for the attach members and attach fittings for the NLS 1 configuration. The interface locations and designations are shown in figure 26, and the attach member loads designations are shown in figure 27. The NLS 1 core stage loads were developed for the point of maximum combined bending load, while the NLS 2 approach assumed all vehicle loads to lie in the plane of the wind.

The various combined loads presented in the results were computed as follows:

$$P_{eq} = P\text{-equivalent load}$$

$$= P \pm \frac{2M}{R}$$

$$N_v = \text{line load for combined normal shear and torsion}$$

$$= \frac{V}{2\pi R} \pm \frac{T}{\pi R^2}$$

where,

$$V = \text{normal shear load}$$

$$T = \text{torsional moment}$$

$$V_{eq} = \text{shear-equivalent load} = 2P \pm \frac{V}{R}$$

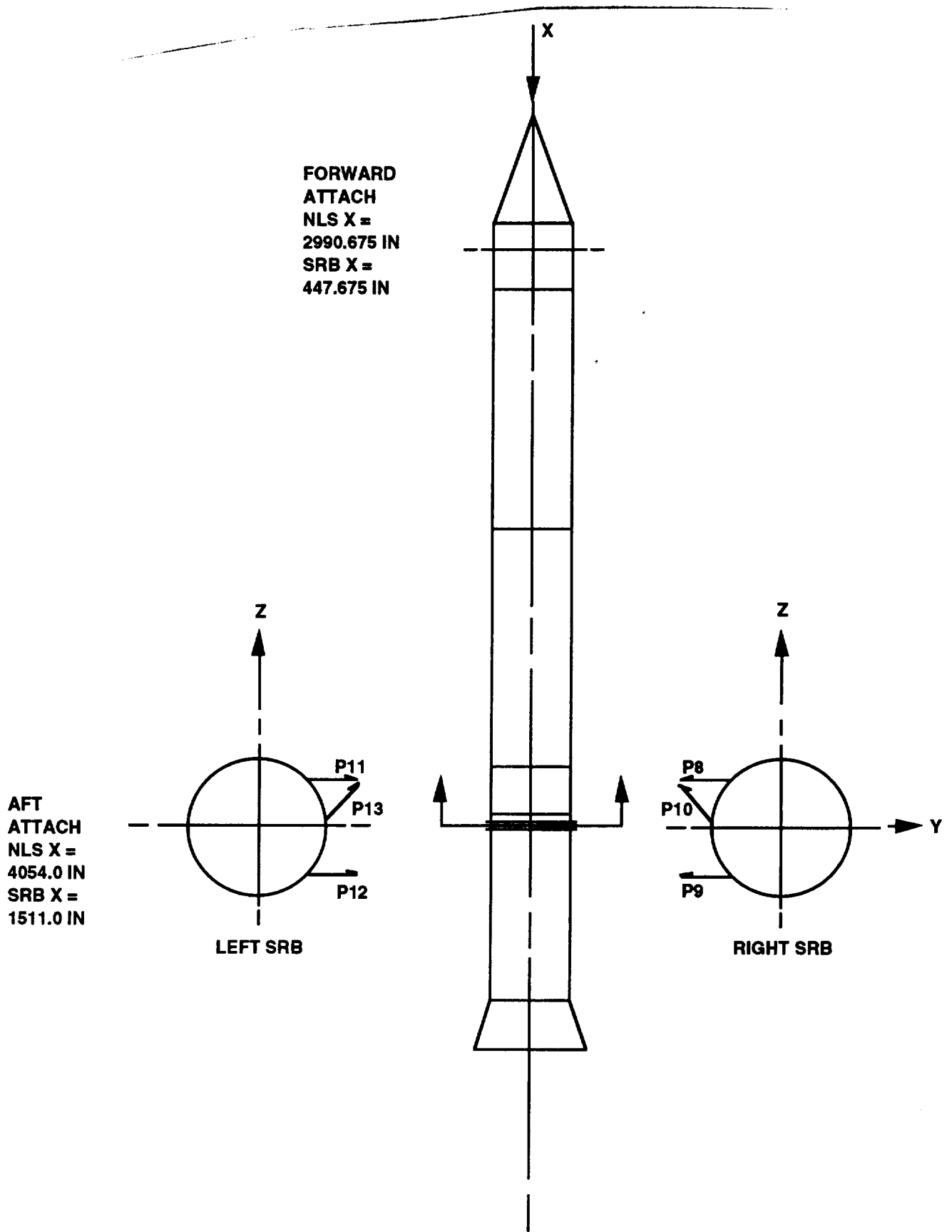

Figure 27. ASRB interface loads locations and directions.

N_x line loads were defined in section A.3. The flight conditions analyzed included the following conditions:

1. Maximum dynamic pressure (max-q)
2. Maximum acceleration (max-g)
3. ASRB separation (NLS 1 only)
4. STME engine-out cases (NLS 1 and NLS 2).

The following assumptions were utilized in the analysis:

1. ASRB separation loads were computed assuming a 200-kip variation on the tailoff thrust (i.e., one engine at zero thrust and one engine at 200-kips thrust).
2. Uncertainty factor of $k_v = 1.05$ was applied to axial loads to account for thrust oscillations during max-g flight regimes.
3. Vehicle parameter dispersions were utilized in a 3- σ RSS combination including (a) ± 25 percent on aerodynamic data and (b) ± 3 percent on STME and ASRB thrust levels.

For purposes of this analysis, the vehicle mass and c.g. were assumed to be the nominal values. Elastic body loads were not included in the analysis. Conservatism in the wind criteria and the large uncertainty represented by the aerodynamic tolerances should envelope the dynamic loads.

2. Input Data Requirements and Sources

a. Vehicle Aerodynamics

Vehicle aerodynamic data were furnished by the aerodynamics group as separate data bases for the two configurations.^{9 10 11} For the NLS 1 configuration, data were provided as discrete or point loads and as distributed loads. The discrete loads were provided over the range of interest (Mach 0.6 to 5.0) for the left and right ASRM's and the CCS. The loads on each body were further broken down into smaller increments for key vehicle segments such as the nose cap assembly, shroud, etc. The discrete data included normal and side force, axial force, and pitching, yawing, and rolling moment coefficient data. A base force increment for each body was also provided as a function of altitude.

Distributed aerodynamic coefficient data were provided for the core stage as a function of x/D at four selected Mach numbers—Mach 0.9, 1.25, 1.46, and 2.0. The data base included separate data for the side force and normal force distributions due to the interference effects of the ASRM's on the side force distributions. Other Mach regimes were obtained by extrapolation or interpolation. The base force increment was applied to the CCS base as a discrete load. Since the ASRM's were already designed, this study assumed that only the core stage required a detailed loads assessment. The boosters were modeled using discrete aerodynamic loads data.

For the NLS 2 configuration, discrete and distributed aerodynamic data bases were provided over the same Mach ranges as for NLS 1. The discrete data contained the normal force, axial force, and pitching moment coefficient data as well as a base force increment. The distributed data included distributed normal force and axial force data. The same base force increment data were applied in a discrete

fashion to the base region. All loads were assumed to lie in the plane of the wind to simplify the loads calculation.

b. Winds Criteria

All high altitude wind-speed speeds were selected from reference 6. The following criteria were selected to satisfy design requirements:

1. 95-percent annual wind speed envelope
2. 99-percent scalar shears and gust reduced 15 percent.

The wind speed was varied at 12 clockwise azimuth increments and at constant altitude levels ranging from 3 to 15 km.

c. Control System Data

The squatcheloid data were developed using a rigid body vehicle model and a simple altitude and altitude rate (i.e., no load relief) control system. A few squatcheloids were generated for a load relief control system and were assessed to give an indication of the load reduction which could be achieved.

A simplified engine mixing logic was assumed for the analysis. All engines were assumed to act equally in pitch and yaw for both configurations. Roll control was assumed as follows for purposes of the loads analysis:

1. NLS 1 roll control provided by ASRB's
2. NLS 2 roll control provided by two center engines.

The A-factor approach was used to obtain the RSS control response trajectory. The data variations were scaled proportionately to the A-factor and were applied in the direction indicated to maximize the vehicle loads. The trajectory variation amounted to a delta load of 500 lb/ft² in the worst direction. This delta was added to the squatcheloid data prior to the loads computation. Vehicle distributed loads were assessed for nominal aerodynamic distribution with a ± 25 -percent aerodynamic variation included.

d. Trajectory Data

The design reference trajectories of references 7 and 8 were utilized by the control group to develop the control system response trajectories required in the analysis. The basic trajectories selected for loads assessment included the following conditions:

1. NLS 1 vehicle with one STME engine out at lift-off and 100-kip payload to orbit.
2. NLS 1 vehicle with no STME engine out and 100-kip payload to orbit.
3. NLS 2 vehicle with one STME engine out at lift-off and 50-kip payload to orbit.
4. NLS 2 vehicle with no STME engine out.

For the NLS 1 nominal trajectory, the maximum acceleration (max-g) was limited to 4.0 g's. The dynamic pressure was also constrained to the STME engine-out case maximum value in shaping the trajectory. The NLS 2 nominal trajectory maximum acceleration (max-g) was limited to 4.5 g's, and the dynamic pressure was constrained to NLS 2 engine-out trajectory maximum value.

e. Engine-Out Conditions

Since the NLS vehicles are designed to perform their missions with one liquid engine out, a separate analysis was performed to assess the resulting loads. Both the NLS 1 and NLS 2 configurations used throttling of the liquid engines to reduce the maximum dynamic pressure during the atmospheric portion of flight. The nominal throttle setting of the STME's was established at the 75-percent power level. In the event of an engine out, the remaining STME's would be throttled up to 100-percent power level. Throttling was also used during vacuum flight to maintain the maximum acceleration requirements.

For the NLS 1 configuration, it was assumed that the thrust level would be approximately the same for engine-out condition due to throttling up. Therefore, the control responses were assumed to be the same as for all engines burning.

For the NLS 2 configuration, two basic engine-out conditions were examined:

1. Engine out at lift-off
2. One engine out during max-q.

The engine out at lift-off case was characterized by engine No. 2 thrust going to zero at 1 second after ignition. The engine out during the max-q flight regime was simulated by phasing the wind gust and the time of engine out so that vehicle loads were maximized. This configuration was bounded by engine No. 5 out during head and cross wind cases and by engine No. 4 out during the tail wind case. These combinations represented the worst case scenarios for an engine failure occurring at the time of maximum wind gust.

3. Loads Results for NLS 2

a. Interface Loads

There were no interfaces to be considered in the NLS 2 loads other than the interfaces between the payloads and payload adapter. These data are presented as c.g. acceleration loads in a later section.

b. Distributed Body Loads

For nominal vehicle (no engine out), distributed body loads were calculated for nine squatcheloids generated at the altitudes described in section C.1 plus two maximum acceleration (max-g) cases.

Distributed loads were calculated using six squatcheloids for the STME engine out at lift-off condition. Distributed loads were also calculated for eight individual load cases for the engine out at max-q and for two cases at max-g.

The following body loads were computed for each load case:

1. N_x line loads
2. N_v line shears
3. P-equivalent loads
4. V-equivalent loads
5. Axial (X), Y, and Z direction shears
6. Y and Z direction bending moments.

These loads were computed for each station along the vehicle for each point on the given squatcheloids. The maximums and minimums for each load were then recovered case and station consistently. The plots showing the maximum and minimum loads for each squatcheloid, or altitude, versus X-station are shown in the appendix for the nominal (no engine out) vehicle and for one STME engine out. These plots show the maximum absolute or minimum absolute load for each station plotted with its correct sign. Thus, the shear diagrams may not necessarily show at what axial (X) station the shear changes sign.

The N_x , N_v , P-equivalent, and V-equivalent loads were computed by the formulas in section C.1 and by assuming the structure could be represented as a thin-walled cylinder.

4. Loads Results for NLS 1

a. Interface Loads

For the nominal case (i.e., all engines burning), interface and member loads were computed for the CCS/ASRM interfaces as shown in the appendix. The NLS 1 interfaces are assumed to be similar to the STS interfaces, although the aft strut geometry differs slightly from STS due to the larger diameter ASRM's. These loads included max-q, max-g, and separation of the ASRM from the CCS. These loads represent the overall maximums for all squatcheloid cases and all wind angles. Perturbation cases were generated for the max-q condition and included aerodynamic, thrust, and angular acceleration variations. These cases were combined to provide the load increase or decrease as an RSS increment. The load increments did not significantly increase any of the interface or member loads. Therefore, all ascent loads are presented as nominal values. However, the max-g and separation loads include angular acceleration variations.

All loads were compared to NSTS derived loads and were found to be generally less than the NSTS limits, except for the forward attach axial (X) loads FTB5 and FTB6. The forward attach loads exceeded the NSTS derived data at ASRM separation by 40 to 60 percent. This loading represents the bolt tension load in the forward attach joint and not an overload of the major structure.

The resulting interface loads were merged with the prelaunch and lift-off loads in section III.B and are contained in four tables in the appendix. The ascent loads were generally enveloped by the prelaunch and lift-off events. It is recommended that the NLS interface load increases be combined with the NSTS derived attach fitting and member loads for use in the cycle 2 design.

b. Core Vehicle Distributed Body Loads

Distributed body loads were calculated for 10 squatcheloids, or altitudes, as described in section C.1 plus 2 maximum acceleration (max-g) cases. The same body loads were computed for each load case as shown in section C.3.a.

These loads were computed for each station along the vehicle for each point on the given squatcheloids. The maximums and minimums for each load were then recovered case and station consistently. The plots showing the maximum and minimum loads for each squatcheloid, or altitude, versus axial (X) station are shown in the appendix. These plots show the maximum absolute or minimum absolute for each station plotted with its correct sign. Thus, the shear diagrams may not necessarily show at what X station the shear changes sign.

The N_x , N_y , P-equivalent, and V-equivalent loads were computed by the formulas discussed in section C.4.b assuming a thin-walled cylinder.

5. Maximum/Minimum Loads Summary

The NLS 2 distributed body loads discussed in section C.3.b were searched for the overall maximums and minimums. The results are contained in the appendix as plots of the maximum envelope values with separate curves for max-q and max-g. As noted previously, the Titan shroud capability was exceeded. Figures 14 through 17 show the shroud P-equivalent and V-equivalent loads versus the Titan IV allowables.

NLS 2 component accelerations were searched for the payloads and the results are:

	<u>X-dir</u>	<u>Y-dir</u>	<u>Z-dir</u>	<u>Flight Condition</u>
Payload	-2.1 g's	±1.3 g's	±1.3 g's	max-q
	-4.7 g's	±0.2 g's	±0.2 g's	max-g

The results for the NLS 1 ascent interface and member loads are tabulated in the appendix for the max-q loads and for the combined max-q, max-g, and separation loads. The load results are presented as maximum and minimum (max/min) summaries with general information identifying the squatcheloid case (i.e., altitude) and clock angle at which the extreme values occurred. Separate tables compare the max/min loads with the NSTS derived limits and compute an allowable vehicle margin where:

$$M_A = \text{margin allowable} = \frac{L - L_A}{L_A} 100 \text{ percent}$$

and where,

L = maximum or minimum limit load

L_A = NSTS derived allowable load limit .

All of the loads were generally lower than the NSTS design loads except the separation load exceedances in interface loads FT05 and FT06 (axial loads) as previously noted. These interface loads were in turn enveloped by the lift-off loads. Therefore, any solution to the lift-off exceedance will probably accommodate the separation overload.

The NLS 1 distributed body loads discussed in section C.4.b were then searched for the overall maximums and minimums. Figures 6 through 10 show plots of the maximums with separate curves for max-q and max-g.

NLS 1 component accelerations were searched for the payloads, FPM, and CTV and the results are as follows:

	X-dir	Y-dir	Z-dir	Flight Condition
CTV	-2.3 g's	±0.8 g's	±0.7 g's	max-q
	-4.2 g's	±0.1 g's	±0.1 g's	max-g
FPM	-2.3 g's	±1.3 g's	±1.2 g's	max-q
	-4.2 g's	±0.2 g's	±0.2 g's	max-g
Payload	-2.5 g's	±1.3 g's	±1.2 g's	max-q
	-4.2 g's	±0.2 g's	±0.2 g's	max-g

Since no elastic transient analysis was performed for NLS 1 or for NLS 2, an allowance was included for bending and thrust oscillation in the acceleration results.

REFERENCES

1. National Launch System (NLS) Reference Launch Vehicles Definition Document, May 1991.
2. Working drawings and sketches of the NLS 1 and NLS 2 configurations.
3. ED53-31-91, "National Launch System (NLS) Reference Document Coordinate System and External Configuration," July 1, 1991.
4. NLS 1 and NLS 2 Mass Properties Versus Flight Time. Working papers from EL42 including magnetic disk files, 1991.
5. "Terrestrial Environment (Climatic) Criteria for Use in Aerospace Vehicle Development," NASA TM 82473, 1982 Revision.
6. "The Documentation of the Natural Environment Currently in Use for NLS Design, ES44-243-91, December 3, 1991.
7. "National Launch System Heavy Lift Launch Vehicle (HLLV) Nominal and Engine-Out Reference Mission Trajectories," EP55-91-99, August 29, 1991.
8. "National Launch System Stage 1.5 Vehicle Ascent Trajectory Performance Analyses for Engine-Out and Nominal Trajectories," EP55-91-102, August 7, 1991.
9. "Aerodynamic Data Base for the One and One-Half Stage (1.5-RV10603) and the Heavy Lift Launch Vehicle (HLV-RV10607) Configurations for the National Launch System," ED35-25-91, July 1, 1991.
10. "Distributed Loads on the National Launch System One and One-Half Stage Launch Vehicle," ED35-88-91, September 18, 1991.
11. "Distributed Loads on the National Launch System Heavy Lift Launch Vehicle Core Element," ED35-134-91, December 31, 1991.
12. "ASRM Lift-Off Cases to Support Cycle 1 NLS Lift-Off Loads Analysis," EP55-91-143, November 25, 1991.
13. "NLS Cycle 1 Ignition Overpressure Environments," ED33-103-91, October 2, 1991.
14. EP55 working papers, STME thrust data for NLS Cycle 1 loads analysis.
15. Craig, R.R. Jr., and Bampton, M.C.C.: "Coupling of Substructures for Dynamic Analysis." AIAA Journal, vol. 6, July 1968, pp. 1313-1319.
16. "A Transient Response Method for Linear Coupled Substructures," NASA TP 2926, December 1989.
17. "National Launch System (NLS) Cycle 1 Ascent Control Squatcheloids," ED13-07-92, February 1992.

18. "Longitudinal Mass-Spring Modeling of Launch Vehicles," NASA TN D-5371, August 1969.
19. McDonnell Douglas: "Prime Item Development Specification for Titan IV Payload Fairing Configuration Item No. DA200-1." Rev. A, October 2, 1989.



APPENDIX

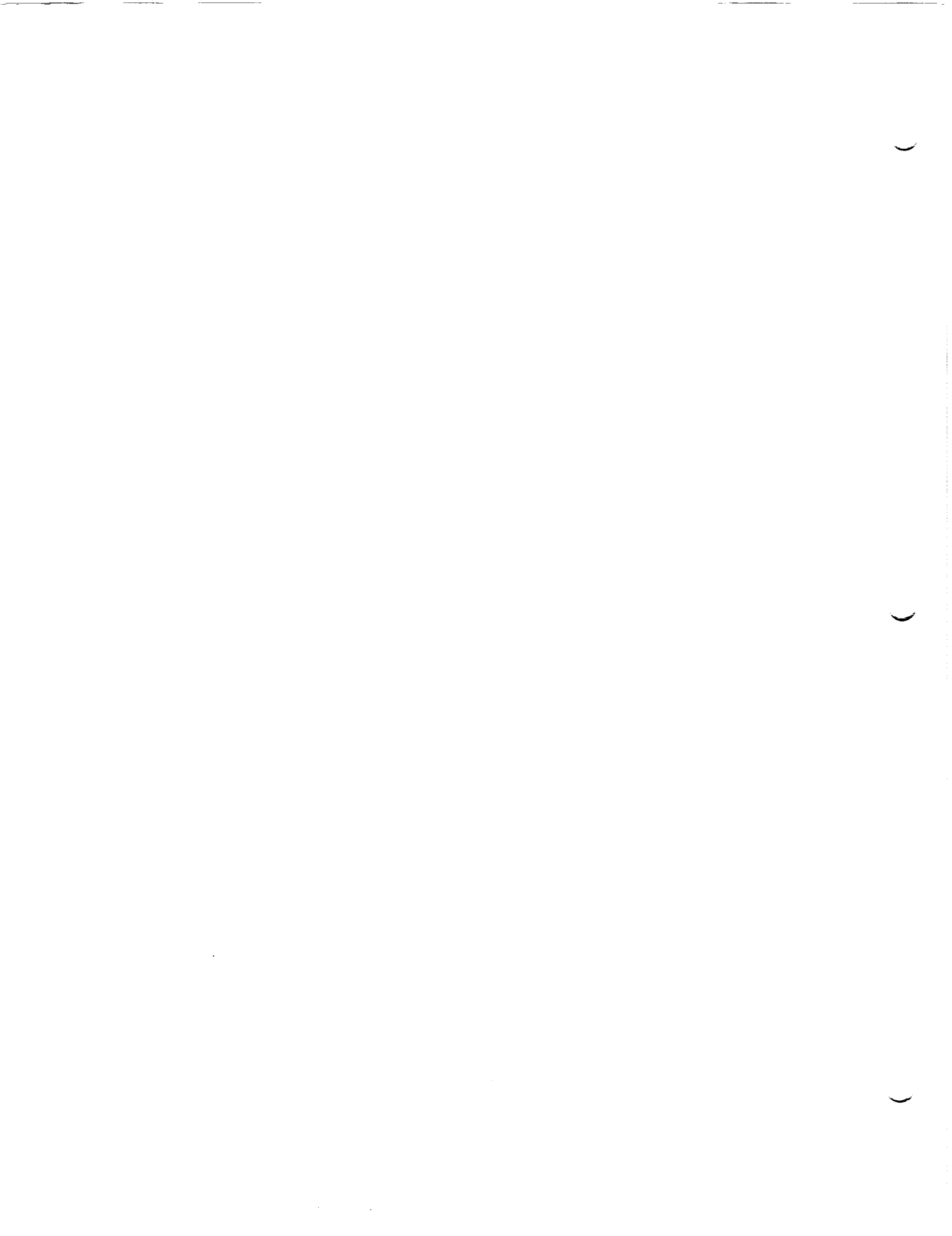

APPENDIX
LIST OF TABLES

Title	Page No.
MATH MODEL DATA	
NLS 1 Mass Properties.....	A-1
NLS 2 Mass Properties.....	A-2
NLS 1 Map.....	A-3
NLS 1 Bulk Data.....	A-7
NLS 2 Map.....	A-13
NLS 2 Bulk Data.....	A-21
NLS 1 Frequencies.....	A-39
NLS 2 Frequencies.....	A-40
FORCING FUNCTION DATA	
ASRB Thrust and Pressure Case Description.....	A-41
NLS 1 Buildup/Shutdown Forcing Function Cases.....	A-42
NLS 1 Lift-Off Forcing Function Cases.....	A-44
NLS 2 Buildup/Shutdown Forcing Function Cases.....	A-47
NLS 2 Lift-Off Forcing Function Cases.....	A-48
NLS 1 PRELAUNCH DATA	
NLS 1 Buildup/Shutdown Pad Forces With STME Out.....	A-76
NLS 1 Buildup/Shutdown Pad Forces Without STME Out.....	A-77
NLS 1 Buildup/Shutdown Accelerations.....	A-78
NLS 1 Buildup/Shutdown Interface Loads.....	A-79
NLS 1 14-Day and 180-Day Static Forces.....	A-80
NLS 1 Composite Shear Buildup/Shutdown Loads With STME Out.....	A-85
NLS 1 Composite Moment Buildup/Shutdown Loads With STME Out.....	A-86
NLS 1 Composite Line Buildup/Shutdown Loads With STME Out.....	A-87
NLS 1 Composite Shear Buildup/Shutdown Loads Without STME Out.....	A-96
NLS 1 Composite Moment Buildup/Shutdown Loads Without STME Out.....	A-97
NLS 1 Composite Line Buildup/Shutdown Loads Without STME Out.....	A-98
NLS 2 PRELAUNCH DATA	
NLS 2 Buildup/Shutdown Pad Forces With STME Out.....	A-107
NLS 2 Buildup/Shutdown Pad Forces Without STME Out.....	A-108
NLS 2 Buildup/Shutdown Accelerations.....	A-109
NLS 2 14-Day and 180-Day Static Forces.....	A-110
NLS 2 Composite Shear Buildup/Shutdown Loads With STME Out.....	A-113
NLS 2 Composite Moment Buildup/Shutdown Loads With STME Out.....	A-114
NLS 2 Composite Line Buildup/Shutdown Loads With STME Out.....	A-115
NLS 2 Composite Shear Buildup/Shutdown Loads Without STME Out.....	A-124
NLS 2 Composite Moment Buildup/Shutdown Loads Without STME Out.....	A-125
NLS 2 Composite Line Buildup/Shutdown Loads Without STME Out.....	A-126

LIST OF TABLES (Continued)

Title	Page No.
NLS 1 LIFT-OFF DATA	
NLS 1 Lift-Off Pad Forces With STME Out.....	A-135
NLS 1 Lift-Off Pad Forces Without STME Out.....	A-136
NLS 1 Lift-Off Accelerations	A-137
NLS 1 Lift-Off Interface Loads	A-138
NLS 1 Composite Shear Lift-Off Loads With STME Out.....	A-139
NLS 1 Composite Moment Lift-Off Loads With STME Out.....	A-140
NLS 1 Composite Line Lift-Off Loads With STME Out	A-141
NLS 1 Composite Shear Lift-Off Loads Without STME Out	A-150
NLS 1 Composite Moment Lift-Off Loads Without STME Out.....	A-151
NLS 1 Composite Line Lift-Off Loads Without STME Out.....	A-152
NLS 2 LIFT-OFF DATA	
NLS 2 Lift-Off Pad Forces With STME Out.....	A-161
NLS 2 Lift-Off Pad Forces Without STME Out.....	A-162
NLS 2 Lift-Off Accelerations	A-163
NLS 2 Composite Shear Lift-Off Loads With STME Out.....	A-164
NLS 2 Composite Moment Lift-Off Loads With STME Out.....	A-165
NLS 2 Composite Line Lift-Off Loads With STME Out	A-166
NLS 2 Composite Shear Lift-Off Loads Without STME Out	A-175
NLS 2 Composite Moment Lift-Off Loads Without STME Out.....	A-176
NLS 2 Composite Line Lift-Off Loads Without STME Out.....	A-177
INTERFACE LOADS SUMMARY	
NLS 1 Loads Summary	A-197

APPENDIX

LIST OF FIGURES

Title	Page No.
FORCING FUNCTION DATA	
Ignition and shutdown STME thrust versus time.....	A-49
ASRM thrust data A1 thrust and head pressure versus time.....	A-50
ASRM thrust data A2 thrust and head pressure versus time.....	A-51
ASRM thrust data A3 thrust and head pressure versus time.....	A-52
ASRM thrust data A4 thrust and head pressure versus time.....	A-53
ASRM thrust data A5 thrust and head pressure versus time.....	A-54
ASRM thrust data A6 thrust and head pressure versus time.....	A-55
ASRM thrust data A11 thrust and head pressure versus time.....	A-56
ASRM thrust data A12 thrust and head pressure versus time.....	A-57
ASRM thrust data A13 thrust and head pressure versus time.....	A-58
ASRM thrust data A14 thrust and head pressure versus time.....	A-59
ASRM thrust data A15 thrust and head pressure versus time.....	A-60
ASRM thrust data A20 thrust and head pressure versus time.....	A-61
ASRM thrust data A21 thrust and head pressure versus time.....	A-62
Overpressure forces versus time node 3 Z-dir	A-63
Overpressure forces versus time node 6 Z-dir	A-64
Overpressure forces versus time node 11 Z-dir	A-65
Overpressure forces versus time node 17 Z-dir	A-66
Overpressure forces versus time node 23 Z-dir	A-67
Overpressure forces versus time node 28 Z-dir	A-68
Overpressure forces versus time node 33 Z-dir	A-69
Over pressure forces versus time node 37 Z-dir	A-70
Overpressure forces versus time Node 40 Z-dir.....	A-71
Overpressure forces versus time ASRB Sta-2873 Z-dir	A-72
Overpressure forces versus time ASRB Sta-3394.48 Z-dir	A-73
Overpressure forces versus time ASRB Sta-3928.46 Z-dir	A-74
Overpressure forces versus time ASRB Sta-4373 Z-dir	A-75
NLS 1 PRELAUNCH DATA STATIC LOADS	
Static Y-dir shear load versus X-station.....	A-81
Static Z-dir shear loads versus X-station.....	A-82
Static Y-dir moment versus X-station.....	A-83
Static Z-dir moment versus X-station	A-84
WITH STME OUT	
Composite axial shear loads.....	A-88
Composite Y-dir shear loads versus X-station.....	A-89
Composite Z-dir shear loads versus X-station	A-90
Composite X-dir torsion versus X-station.....	A-91
Composite Y-dir moment versus X-station.....	A-92
Composite Z-dir moment versus X-station	A-93

LIST OF FIGURES (Continued)

Title	Page No.
Composite Nx+ loads versus X-station.....	A-94
Composite Nx- loads versus X-station.....	A-95
 WITHOUT STME OUT	
Composite axial shear loads versus X-station.....	A-99
Composite Y-dir shear loads versus X-station.....	A-100
Composite Z-dir shear loads versus X-station.....	A-101
Composite X-dir torsion versus X-station.....	A-102
Composite Y-dir moment versus X-station.....	A-103
Composite Z-dir moment versus X-station.....	A-104
Composite Nx+ loads versus X-station.....	A-105
Composite Nx- loads versus X-station.....	A-106
 NLS 2 PRELAUNCH DATA STATIC LOADS	
Static transverse shear loads versus X-station.....	A-111
Static bending moment versus X-station.....	A-112
 WITH STME OUT	
Composite axial shear loads versus X-station.....	A-116
Composite Y-dir shear loads versus X-station.....	A-117
Composite Z-dir shear loads versus X-station.....	A-118
Composite X-dir torsion versus X-station.....	A-119
Composite Y-dir moment versus X-station.....	A-120
Composite Z-dir moment versus X-station.....	A-121
Composite Nx+ loads versus X-station.....	A-122
Composite Nx- loads versus X-station.....	A-123
 WITHOUT STME OUT	
Composite axial shear loads versus X-station.....	A-127
Composite Y-dir shear loads versus X-station.....	A-128
Composite Z-dir shear loads versus X-station.....	A-129
Composite X-dir torsion versus X-station.....	A-130
Composite Y-dir moment versus X-station.....	A-131
Composite Z-dir moment versus X-station.....	A-132
Composite Nx+ loads versus X-station.....	A-133
Composite Nx- loads versus X-station.....	A-134
 NSL 1 LIFT-OFF DATA WITH STME OUT	
Composite axial shear loads versus X-station.....	A-142
Composite Y-dir shear loads versus X-station.....	A-143
Composite Z-dir shear loads versus X-station.....	A-144

LIST OF FIGURES (Continued)

Title	Page No.
Composite X-dir torsion versus X-station.....	A-145
Composite Y-dir moment versus X-station.....	A-146
Composite Z-dir moment versus X-station.....	A-147
Composite Nx+ loads versus X-station.....	A-148
Composite Nx- loads versus X-station.....	A-149
 WITHOUT STME OUT	
Composite axial shear loads versus X-station.....	A-153
Composite Y-dir shear loads versus X-station.....	A-154
Composite Z-dir shear loads versus X-station.....	A-155
Composite X-dir torsion versus X-station.....	A-156
Composite Y-dir moment versus X-station.....	A-157
Composite Z-dir moment versus X-station.....	A-158
Composite Nx+ loads versus X-station.....	A-159
Composite Nx- loads versus X-station.....	A-160
 NLS 2 LIFT-OFF DATA WITH STME OUT	
Composite axial shear loads versus X-station.....	A-167
Composite Y-dir shear loads versus X-station.....	A-168
Composite Z-dir shear loads versus X-station.....	A-169
Composite X-dir torsion versus X-station.....	A-170
Composite Y-dir moment versus X-station.....	A-171
Composite Z-dir moment versus X-station.....	A-172
Composite Nx+ loads versus X-station.....	A-173
Composite Nx- loads versus X-station.....	A-174
 WITHOUT STME OUT	
Composite axial shear loads versus X-station.....	A-178
Composite Y-dir shear loads versus X-station.....	A-179
Composite Z-dir shear loads versus X-station.....	A-180
Composite X-dir torsion versus X-station.....	A-181
Composite Y-dir moment versus X-station.....	A-182
Composite Z-dir moment versus X-station.....	A-183
Composite Nx+ loads versus X-station.....	A-184
Composite Nx- loads versus X-station.....	A-185
 NLS 1 AND NLS 2 PRELAUNCH AND LIFT-OFF LINE LOAD COMPARISONS	
NLS 1 Nx max-min comparison versus X-station with STME out.....	A-186
NLS 1 Nx max-min comparison versus X-station without STME out.....	A-187
NLS 2 Nx max-min comparison versus X-station with STME out.....	A-188
NLS 2 Nx max-min comparison versus X-station without STME out.....	A-189
NLS 1 and NLS 2 Nx comparison versus X-station with STME out.....	A-190
NLS 1 and NLS 2 Nx comparison versus X-station without STME out.....	A-191

LIST OF FIGURES (Continued)

Title	Page No.
ASCENT LINE LOAD COMPARISON	
NLS 1 AND NLS 2 OVERALL LINE LOAD COMPARISON	
NLS 1 Nx event comparison without STME out.....	A-192
NLS 2 Nx event comparison with STME out.....	A-193
NLS 2 Nx event comparison without STME out.....	A-194
NLS 1 and NLS 2 Nx event comparison with STME out.....	A-195
NLS 1 and NLS 2 Nx event comparison without STME out.....	A-196
NLS 1 AND NLS 2 COMPARISON WITH CYCLE 0 BASELINE LOADS	
NLS 1 prelaunch Nx cycle comparison.....	A-198
NLS 2 prelaunch Nx cycle comparison.....	A-199
NLS 1 max-q Nx cycle comparison.....	A-200
NLS 2 max-q Nx cycle comparison.....	A-201
NLS 1 static Nx cycle comparison.....	A-202
NLS 2 static Nx cycle comparison.....	A-203
NLS 1 SQUATCHELOIDS	
NLS 1 nominal 3-km winds with no load relief.....	A-204
NLS 1 nominal 4-km winds with no load relief.....	A-205
NLS 1 nominal 5-km winds with no load relief.....	A-206
NLS 1 nominal 6-km winds with no load relief.....	A-207
NLS 1 nominal 8-km winds with no load relief.....	A-208
NLS 1 nominal 10-km winds with no load relief.....	A-209
NLS 1 nominal 11-km winds with no load relief.....	A-210
NLS 1 nominal 12-km winds with no load relief.....	A-211
NLS 1 nominal 13-km winds with no load relief.....	A-212
NLS 1 nominal 15-km winds with no load relief.....	A-213
NLS 2 SQUATCHELOIDS	
NLS 2 nominal 3-km winds with no load relief.....	A-214
NLS 2 nominal 6-km winds with no load relief.....	A-215
NLS 2 nominal 8-km winds with no load relief.....	A-216
NLS 2 nominal 9-km winds with no load relief.....	A-217
NLS 2 nominal 10-km winds with no load relief.....	A-218
NLS 2 nominal 11-km winds with no load relief.....	A-219
NLS 2 nominal 12-km winds with no load relief.....	A-220
NLS 2 nominal 13-km winds with no load relief.....	A-221
NLS 2 nominal 14-km winds with no load relief.....	A-222
NLS 2 ENGINE OUT AT LIFT-OFF SQUATCHELOID	
NLS 2 engine out at lift-off 6-km winds with no load relief.....	A-223
NLS 2 engine out at lift-off 8-km winds with no load relief.....	A-224

LIST OF FIGURES (Continued)

Title	Page No.
NLS 2 engine out at lift-off 10-km winds with no load relief.....	A-225
NLS 2 engine out at lift-off 12-km winds with no load relief.....	A-226
NLS 2 engine out at lift-off 13-km winds with no load relief.....	A-227
NLS 2 engine out at lift-off 14-km winds with no load relief.....	A-228
 NLS 1 CORE – ASCENT	
Overall maximum N_x versus X-station.....	A-229
Overall maximum N_v versus X-station.....	A-230
Overall maximum P equivalent versus X-station.....	A-231
Overall maximum V equivalent versus X-station.....	A-232
Overall maximum axial shear versus X-station.....	A-233
Overall maximum shear – Y direction versus X-station.....	A-234
Overall maximum shear – Z direction versus X-station.....	A-235
Overall maximum moment – Y direction versus X-station.....	A-236
Overall maximum moment – Z direction versus X-station.....	A-237
 NLS 1 CORE – 3 km	
N_x versus X-station.....	A-238
N_v versus X-station.....	A-239
Axial shear versus X-station.....	A-240
Y direction shear versus X-station.....	A-241
Z direction shear versus X-station.....	A-242
Y direction moment versus X-station.....	A-243
Z direction moment versus X-station.....	A-244
 NLS 1 CORE – 4 km	
N_x versus X-station.....	A-245
N_v versus X-station.....	A-246
Axial shear versus X-station.....	A-247
Y direction shear versus X-station.....	A-248
Z direction shear versus X-station.....	A-249
Y direction moment versus X-station.....	A-250
Z direction moment versus X-station.....	A-251
 NLS 1 CORE – 5 km	
N_x versus X-station.....	A-252
N_v versus X-station.....	A-253
Axial shear versus X-station.....	A-254
Y direction shear versus X-station.....	A-255
Z direction shear versus X-station.....	A-256
Y direction moment versus X-station.....	A-257
Z direction moment versus X-station.....	A-258

LIST OF FIGURES (Continued)

Title	Page No.
NLS 1 CORE – 6 km	
Nx versus X-station.....	A-259
Nv versus X-station.....	A-260
Axial shear versus X-station	A-261
Y direction shear versus X-station	A-262
Z direction shear versus X-station.....	A-263
Y direction moment versus X-station.....	A-264
Z direction moment versus X-station.....	A-265
NLS 1 CORE – 8 km	
Nx versus X-station.....	A-266
Nv versus X-station.....	A-267
Axial shear versus X-station	A-268
Y direction shear versus X-station	A-269
Z direction shear versus X-station.....	A-270
Y direction moment versus X-station.....	A-271
Z direction moment versus X-station.....	A-272
NLS 1 CORE – 10 km	
Nx versus X-station.....	A-273
Nv versus X-station.....	A-274
Axial shear versus X-station	A-275
Y direction shear versus X-station	A-276
Z direction shear versus X-station.....	A-277
Y direction moment versus X-station.....	A-278
Z direction moment versus X-station.....	A-279
NLS 1 CORE – 11 km	
Nx versus X-station.....	A-280
Nv versus X-station.....	A-281
Axial shear versus X-station	A-282
Y direction shear versus X-station	A-283
Z direction shear versus X-station.....	A-284
Y direction moment versus X-station.....	A-285
Z direction moment versus X-station.....	A-286
NLS 1 CORE – 12 km	
Nx versus X-station.....	A-287
Nv versus X-station.....	A-288
Axial shear versus X-station	A-289
Y direction shear versus X-station	A-290

LIST OF FIGURES (Continued)

Title	Page No.
Z direction shear versus X-station.....	A-291
Y direction moment versus X-station.....	A-292
Z direction moment versus X-station.....	A-293
 NLS 1 CORE – 13 km	
Nx versus X-station.....	A-294
Nv versus X-station.....	A-295
Axial shear versus X-station	A-296
Y direction shear versus X-station	A-297
Z direction shear versus X-station.....	A-298
Y direction moment versus X-station.....	A-299
Z direction moment versus X-station.....	A-300
 NLS 1 CORE – 15 km	
Nx versus X-station.....	A-301
Nv versus X-station.....	A-302
Axial shear versus X-station	A-303
Y direction shear versus X-station	A-304
Z direction shear versus X-station.....	A-305
Y direction moment versus X-station.....	A-306
Z direction moment versus X-station.....	A-307
 NLS 1 CORE – MAX-G FIRST STAGE	
Nx versus X-station.....	A-308
Nv versus X-station.....	A-309
Axial shear versus X-station	A-310
Y direction shear versus X-station	A-311
Z direction shear versus X-station.....	A-312
Y direction moment versus X-station.....	A-313
Z direction moment versus X-station.....	A-314
 NLS 1 CORE – MAX-G SECOND STAGE	
Nx versus X-station.....	A-315
Nv versus X-station.....	A-316
Axial shear versus X-station	A-317
Y direction shear versus X-station	A-318
Z direction shear versus X-station.....	A-319
Y direction moment versus X-station.....	A-320
Z direction moment versus X-station.....	A-321

LIST OF FIGURES (Continued)

Title	Page No.
NLS 2 CORE – SHROUD LOADS VERSUS TITAN IV ALLOWABLES	
Ascent – overall maximum P equivalent.....	A-322
Ascent – overall maximum V equivalent.....	A-323
Ascent engine out – overall maximum P equivalent.....	A-324
Ascent engine out – overall maximum V equivalent.....	A-325
NLS 2 CORE – ASCENT	
Overall maximum Nx versus X-station.....	A-326
Overall maximum Nv versus X-station.....	A-327
Overall maximum P equivalent versus X-station.....	A-328
Overall maximum V equivalent versus X-station.....	A-329
Overall maximum axial shear versus X-station.....	A-330
Overall maximum shear – Y direction versus X-station.....	A-331
Overall maximum shear – Z direction versus X-station.....	A-332
Overall maximum moment – Y direction versus X-station.....	A-333
Overall maximum moment – Z direction versus X-station.....	A-334
NLS 2 CORE – 3 km	
Nx versus X-station.....	A-335
Nv versus X-station.....	A-336
Axial shear versus X-station.....	A-337
Y direction shear versus X-station.....	A-338
Z direction shear versus X-station.....	A-339
Y direction moment versus X-station.....	A-340
Z direction moment versus X-station.....	A-341
P equivalent (shroud) versus X-station.....	A-342
V equivalent (shroud) versus X-station.....	A-343
NLS CORE – 6 km	
Nx versus X-station.....	A-344
Nv versus X-station.....	A-345
Axial shear versus X-station.....	A-346
Y direction shear versus X-station.....	A-347
Z direction shear versus X-station.....	A-348
Y direction moment versus X-station.....	A-349
Z direction moment versus X-station.....	A-350
P equivalent (shroud) versus X-station.....	A-351
V equivalent (shroud) versus X-station.....	A-352
NLS 2 CORE – 8 km	
Nx versus X-station.....	A-353
Nv versus X-station.....	A-354

LIST OF FIGURES (Continued)

Title	Page No.
Axial shear versus X-station	A-355
Y direction shear versus X-station	A-356
Z direction shear versus X-station.....	A-357
Y direction moment versus X-station.....	A-358
Z direction moment versus X-station.....	A-359
P equivalent (shroud) versus X-station	A-360
V equivalent (shroud) versus X-station.....	A-361
 NLS 2 CORE – 9 km	
Nx versus X-station.....	A.362
Nv versus X-station.....	A-363
Axial shear versus X-station	A-364
Y direction shear versus X-station	A-365
Z direction shear versus X-station.....	A-366
Y direction moment versus X-station.....	A-367
Z direction moment versus X-station.....	A-368
P equivalent (shroud) versus X-station	A-369
V equivalent (shroud) versus X-station.....	A-370
 NLS 2 CORE – 10 km	
Nx versus X-station.....	A-371
Nv versus X-station.....	A-372
Axial shear versus X-station	A-373
Y direction shear versus X-station	A-374
Z direction shear versus X-station.....	A-375
Y direction moment versus X-station.....	A-376
Z direction moment versus X-station.....	A-377
P equivalent (shroud) versus X-station	A-378
V equivalent (shroud) versus X-station.....	A-379
 NLS 2 CORE – 11 km	
Nx versus X-station.....	A-380
Nv versus X-station.....	A-381
Axial shear versus X-station	A-382
Y direction shear versus X-station	A-383
Z direction shear versus X-station.....	A-384
Y direction moment versus X-station.....	A-385
Z direction moment versus X-station.....	A-386
P equivalent (shroud) versus X-station	A-387
V equivalent (shroud) versus X-station.....	A-388

LIST OF FIGURES (Continued)

Title	Page No.
NLS 2 CORE – 12 km	
Nx versus X-station.....	A-389
Nv versus X-station.....	A-390
Axial shear versus X-station	A-391
Y direction shear versus X-station	A-392
Z direction shear versus X-station.....	A-393
Y direction moment versus X-station.....	A-394
Z direction moment versus X-station.....	A-395
P equivalent (shroud) versus X-station	A-396
V equivalent (shroud) versus X-station.....	A-397
NLS 2 CORE – 13 KM	
Nx versus X-station.....	A-398
Nv versus X-station.....	A-399
Axial shear versus X-station	A-400
Y direction shear versus X-station	A-401
Z direction shear versus X-station.....	A-402
Y direction moment versus X-station.....	A-403
Z direction moment versus X-station.....	A-404
P equivalent (shroud) versus X-station	A-405
V equivalent (shroud) versus X-station.....	A-406
NLS 2 CORE – 14 km	
Nx versus X-station.....	A-407
Nv versus X-station.....	A-408
Axial shear versus X-station	A-409
Y direction shear versus X-station	A-410
Z direction shear versus X-station.....	A-411
Y direction moment versus X-station.....	A-412
Z direction moment versus X-station.....	A-413
P equivalent (shroud) versus X-station	A-414
V equivalent (shroud) versus X-station.....	A-415
NLS 2 CORE – MAX-G FIRST STAGE	
Nx versus X-station.....	A-416
Nv versus X-station.....	A-417
Axial shear versus X-station	A-418
Y direction shear versus X-station	A-419
Z direction shear versus X-station.....	A-420
Y direction moment versus X-station.....	A-421
Z direction moment versus X-station.....	A-422
P equivalent (shroud) versus X-station	A-423
V equivalent (shroud) versus X-station.....	A-424

LIST OF FIGURES (Continued)

Title	Page No.
NLS 2 CORE – MAX-G SECOND STAGE	
Nx versus X-station.....	A-425
Nv versus X-station.....	A-426
Axial shear versus X-station	A-427
Y direction shear versus X-station	A-428
Z direction shear versus X-station.....	A-429
Y direction moment versus X-station.....	A-430
Z direction moment versus X-station.....	A-431
P equivalent (shroud) versus X-station	A-432
V equivalent (shroud) versus X-station.....	A-433
NLS 2 CORE – ASCENT ENGINE OUT	
Overall maximum Nx versus X-station.....	A-434
Overall maximum Nv versus X-station.....	A-435
Overall maximum P equivalent versus X-station.....	A-436
Overall maximum V equivalent versus X-station	A-437
Overall maximum axial shear versus X-station	A-438
Overall maximum shear – Y direction versus X-station	A-439
Overall maximum shear – Z direction versus X-station	A-440
Overall maximum moment – Y direction versus X-station	A-441
Overall maximum moment – Z direction versus X-station.....	A-442
NLS 2 CORE – 6 km ENGINE OUT	
Nx versus X-station.....	A-443
Nv versus X-station.....	A-444
Axial shear versus X-station	A-445
Y direction shear versus X-station	A-446
Z direction shear versus X-station.....	A-447
Y direction moment versus X-station.....	A-448
Z direction moment versus X-station.....	A-449
P equivalent (shroud) versus X-station	A-450
V equivalent (shroud) versus X-station.....	A-451
NLS 2 CORE – 8 km ENGINE OUT	
Nx versus X-station.....	A-452
Nv versus X-station.....	A-453
Axial shear versus X-station	A-454
Y direction shear versus X-station	A-455
Z direction shear versus X-station.....	A-456
Y direction moment versus X-station.....	A-457
Z direction moment versus X-station.....	A-458
P equivalent (shroud) versus X-station	A-459
V equivalent (shroud) versus X-station.....	A-460

LIST OF FIGURES (Continued)

Title	Page No.
NLS 2 CORE – 10 km ENGINE OUT	
Nx versus X-station.....	A-461
Nv versus X-station.....	A-462
Axial shear versus X-station	A-463
Y direction shear versus X-station	A-464
Z direction shear versus X-station.....	A-465
Y direction moment versus X-station.....	A-466
Z direction moment versus X-station.....	A-467
P equivalent (shroud) versus X-station	A-468
V equivalent (shroud) versus X-station.....	A-469
NLS 2 CORE – 12 km ENGINE OUT	
Nx versus X-station.....	A-470
Nv versus X-station.....	A-471
Axial shear versus X-station	A-472
Y direction shear versus X-station	A-473
Z direction shear versus X-station.....	A-474
Y direction moment versus X-station.....	A-475
Z direction moment versus X-station.....	A-476
P equivalent (shroud) versus X-station	A-477
V equivalent (shroud) versus X-station.....	A-478
NLS 2 CORE – 13 km ENGINE OUT	
Nx versus X-station.....	A-479
Nv versus X-station.....	A-480
Axial shear versus X-station	A-481
Y direction shear versus X-station	A-482
Z direction shear versus X-station.....	A-483
Y direction moment versus X-station.....	A-484
Z direction moment versus X-station.....	A-485
P equivalent (shroud) versus X-station	A-486
V equivalent (shroud) versus X-station.....	A-487
NLS 2 CORE – 14 km ENGINE OUT	
Nx versus X-station.....	A-488
Nv versus X-station.....	A-489
Axial shear versus X-station	A-490
Y direction shear versus X-station	A-491
Z direction shear versus X-station.....	A-492
Y direction moment versus X-station.....	A-493
Z direction moment versus X-station.....	A-494
P equivalent (shroud) versus X-station	A-495
V equivalent (shroud) versus X-station.....	A-496

MATH MODEL DATA

1

2

3

NLS1 CORE STICK MODEL MASS PROPERTIES

NODE	DESCRIPTION	X - STATION	Structural Wt. (lbs)	Propellant Wt. (lbs)	Payload Wt (lbs)	Total Wt. per Node Fueled	Total Wt. per Node Unfueled
1	Nose Cone	1066.06	20.00			20.00	20.00
2	Nose Cone	1110.60	277.80			277.80	277.80
3	Nose Cone	1155.10	507.70			507.70	507.70
4	Nose Cone	1229.75	995.50			995.50	995.50
45	Forward propulsion module	1274.00	3429.00			3429.00	3429.00
5	Shroud	1304.40	1430.17			1430.17	1430.17
6	Shroud	1411.00	1430.17			1430.17	1430.17
7	Payload #1 and Shroud	1518.00	1430.17		30000.00	31430.17	31430.17
8	Shroud	1625.00	1430.17			1430.17	1430.17
9	Shroud	1732.00	1430.17			1430.17	1430.17
90	Payload #2 and Shroud	1784.40	1430.17		40000.00	41430.17	41430.17
10	Shroud	1839.00	1430.17			1430.17	1430.17
11	Shroud	1946.00	1430.17			1430.17	1430.17
12	Payload #3 and Shroud	2050.80	1430.17		30000.00	31430.17	31430.17
13	Shroud	2160.00	1430.17			1430.17	1430.17
14	Shroud	2264.40	1430.17			1430.17	1430.17
15	Shroud + Adapter	2284.80	8565.17			8565.17	8565.17
16	Transition Section	2340.68	1128.00			1128.00	1128.00
17	Cargo Transfer Vehicle	2342.00	21554.00			21554.00	21554.00
18	Transition Section	2396.57	1128.00			1128.00	1128.00
19	Transition Section and Top of LO2	2459.75	3135.86	205549.33		208685.19	3135.86
20	LO2 Tank & Prop.	2473.80	2007.86	205549.33		207557.19	2007.86
21	LO2 Tank & Prop.	2569.80	2007.86	205549.33		207557.19	2007.86
22	LO2 Tank & Prop.	2664.13	2007.86	205549.33		207557.19	2007.86
23	LO2 Tank & Prop. top Inner Skirt	2758.47	2007.86	205549.33		207557.19	2007.86
24	Bottom LO2 Tank + Inner Skirt	2852.80	5327.86	205549.33		210877.19	5327.86
25	Inner Skirt	2963.43	5327.86	205549.33		210877.19	5327.86
26	Inner Skirt + top LH2 Tank+Prop	2985.68	3320.00	583.33		3903.33	3320.00
27	Bottom of Inner Skirt + LH2	3012.53	6127.92	20099.03		26226.95	6127.92
28	LH2 + Prop.	3123.15	6127.92	20099.03		26226.95	6127.92
29	LH2 + Prop.	3233.63	2807.92	20099.03		22906.95	2807.92
30	LH2 + Prop.	3337.35	2807.92	20099.03		22906.95	2807.92
31	LH2 + Prop.	3480.58	2807.92	20099.03		22906.95	2807.92
32	LH2 + Prop.	3623.80	2807.92	20099.03		22906.95	2807.92
33	LH2 + Prop.	3747.40	2807.92	20099.03		22906.95	2807.92
34	LH2 + Prop.	3871.00	2807.92	20099.03		22906.95	2807.92
35	LH2 + Prop.	3964.50	2807.92	20099.03		22906.95	2807.92
36	LH2 + Prop.+ top aft skirt	4058.00	2807.92	20099.03		22906.95	2807.92
37	LH2 + Prop+ aft skirt	4118.65	3469.26	20099.03		23568.28	3469.26
38	Bottom LH2 +Prop+ aft skirt	4122.65	3469.26	20099.03		23568.28	3469.26
39	aft skirt	4233.28	3469.26	20099.03		23568.28	3469.26
40	aft end of structure	4309.40	25013.00	4187.50		29200.50	25013.00
41	engine	4385.50	25013.00	4187.50		29200.50	25013.00
42	engine	4388.28	8004.00			8004.00	8004.00
43	engine	4388.28	8004.00			8004.00	8004.00
44	engine	4388.28	8004.00			8004.00	8004.00
	6 attach pts (50 lb each)	n/a	300.00			300.00	300.00
TOTALS			205949.00	1709091.00	100000.00	2015040.00	305949.00

NLS2 CORE STICK MODEL MASS PROPERTIES

NODE	DESCRIPTION	X-STATION	STRUCTURAL WT. (LBS)	PROPELLANT WT. (LBS)	PAYLOAD WT (LBS)	TOTAL WT PER NODE FUELED	TOTAL WT PER NODE UNFUELED
1	Nose Cone	1306.06	20.0			20.0	20.0
2	Nose Cone	1395.10	300.0			300.0	300.0
3	Nose Cone	1444.87	548.0			548.0	548.0
4	Nose Cone	1494.64	1076.0			1076.0	1076.0
5	Shroud	1544.40	720.0			720.0	720.0
6	Shroud	1624.40	720.0			720.0	720.0
7	Shroud	1704.40	720.0			720.0	720.0
8	Shroud	1784.40	720.0			720.0	720.0
9	Shroud	1864.40	720.0			720.0	720.0
10	Shroud	1944.40	720.0			720.0	720.0
999	Payload C.G.	1997.58		50000.0		50000.0	50000.0
11	Shroud	2024.40	720.0			720.0	720.0
12	Shroud	2104.40	720.0			720.0	720.0
13	Shroud	2184.40	720.0			720.0	720.0
14	Shroud	2264.40	720.0			720.0	720.0
15	Shroud & Payload Adapter	2284.80	5078.0			5078.0	5078.0
16	Transition Section	2347.80	1128.0			1128.0	1128.0
17	Transition Section	2410.80	1128.0			1128.0	1128.0
18	Transition Section & Top of LO2	2459.18	3135.9	204977.9		208113.8	3135.9
19	LO2 Tank & Prop.	2471.15	2007.9	204977.9		206985.8	2007.9
20	LO2 Tank & Prop.	2569.80	2007.9	204977.9		206985.8	2007.9
21	LO2 Tank & Prop.	2664.13	2007.9	204977.9		206985.8	2007.9
22	LO2 Tank & Prop.	2758.47	2007.9	204977.9		206985.8	2007.9
23	LO2 Tank & Prop. top Inner Skirt	2852.80	4824.9	204977.9		209802.8	4824.9
24	Bottom LO2 Tank & Inner Skirt	2963.43	4824.9	204977.9		209802.8	4824.9
25	Inner Skirt	2985.68	2817.0	583.3		3400.3	2817.0
26	Inner Skirt & top LH2 Tank & Prop.	3012.53	5624.9	20032.2		25657.1	5624.9
27	Bottom of Inner Skirt & LH2	3123.15	5624.9	20032.2		25657.1	5624.9
28	LH2 & Prop.	3240.01	2807.9	20032.2		22840.1	2807.9
29	LH2 & Prop.	3356.86	2807.9	20032.2		22840.1	2807.9
30	LH2 & Prop.	3473.72	2807.9	20032.2		22840.1	2807.9
31	LH2 & Prop.	3590.58	2807.9	20032.2		22840.1	2807.9
32	LH2 & Prop.	3707.43	2807.9	20032.2		22840.1	2807.9
33	LH2 & Prop.	3824.29	2807.9	20032.2		22840.1	2807.9
34	LH2 & Prop.	3941.14	2807.9	20032.2		22840.1	2807.9
35	LH2 & Prop.	4058.00	2807.9	20032.2		22840.1	2807.9
36	LH2 & Prop. & top aft skirt	4090.33	3469.3	20032.2		23501.5	3469.3
37	LH2 & Prop. & aft skirt	4122.65	3469.3	20032.2		23501.5	3469.3
38	Bottom LH2 & Prop. & aft skirt	4233.28	3469.3	20032.2		23501.5	3469.3
803	STME Engine	4385.50	8004.0	729.1		8733.1	8004.0
807	STME Engine	4385.50	8004.0	729.1		8733.1	8004.0
811	STME Engine	4385.50	8004.0	729.1		8733.1	8004.0
815	STME Engine	4385.50	8004.0	729.1		8733.1	8004.0
851	STME Engine	4385.50	8004.0	729.1		8733.1	8004.0
859	STME Engine	4385.50	8004.0	729.1		8733.1	8004.0
	Thrust Structure		69668.3	4000.0		73668.3	69668.3
	TOTALS		201925.5	170422.0	50000.0	1956147.5	251925.5

```

*****
* J. A. BRUNTY * MARSHALL SPACE FLIGHT CENTER *
* * * SYSTEMS DYNAMICS DIVISION * MAP NAME HLLV
* * * CYCLE I STUDY * MODEL NO. BASELINE *
*****
DOFS = 608 BND DOFS = 14 INT DOFS = 594

```

NODE	DESCRIPTION	X COORD			Y COORD			Z COORD			ROW/COL OF MATRIX					
		X	Y	Z	X	Y	Z	X	Y	Z	X	Y	Z	RX	RY	RZ
1	HLLV	1066.060	0.000	0.000	0.000	0.000	0.000	1	2	3	4	5	6			
2	HLLV	1110.600	0.000	0.000	0.000	0.000	0.000	7	8	9	10	11	12			
3	HLLV	1155.100	0.000	0.000	0.000	0.000	0.000	13	14	15	16	17	18			
4	HLLV	1229.750	0.000	0.000	0.000	0.000	0.000	19	20	21	22	23	24			
45	FORWARD PROP MOD	1274.000	0.000	0.000	0.000	0.000	0.000	25	26	27	28	29	30			
5	HLLV	1304.400	0.000	0.000	0.000	0.000	0.000	31	32	33	34	35	36			
6	HLLV	1411.000	0.000	0.000	0.000	0.000	0.000	37	38	39	40	41	42			
7	PAYLOAD #1 30K	1518.000	0.000	0.000	0.000	0.000	0.000	43	44	45	46	47	48			
8	HLLV	1625.000	0.000	0.000	0.000	0.000	0.000	49	50	51	52	53	54			
9	HLLV	1732.000	0.000	0.000	0.000	0.000	0.000	55	56	57	58	59	60			
90	PAYLOAD #2 40K	1784.400	0.000	0.000	0.000	0.000	0.000	61	62	63	64	65	66			
10	HLLV	1839.000	0.000	0.000	0.000	0.000	0.000	67	68	69	70	71	72			
11	HLLV	1946.000	0.000	0.000	0.000	0.000	0.000	73	74	75	76	77	78			
12	PAYLOAD #3 30K	2050.800	0.000	0.000	0.000	0.000	0.000	79	80	81	82	83	84			
13	HLLV	2160.000	0.000	0.000	0.000	0.000	0.000	85	86	87	88	89	90			
14	HLLV	2264.400	0.000	0.000	0.000	0.000	0.000	91	92	93	94	95	96			
46	CTV	2342.000	0.000	0.000	0.000	0.000	0.000	97	98	99	100	101	102			
15	HLLV	2284.800	0.000	0.000	0.000	0.000	0.000	103	104	105	106	107	108			
16	HLLV	2340.680	0.000	0.000	0.000	0.000	0.000	109	110	111	112	113	114			
17	HLLV	2396.570	0.000	0.000	0.000	0.000	0.000	115	116	117	118	119	120			
18	HLLV	2459.170	0.000	0.000	0.000	0.000	0.000	121	122	123	124	125	126			
19	HLLV	2473.800	0.000	0.000	0.000	0.000	0.000	127	128	129	130	131	132			
20	HLLV	2569.800	0.000	0.000	0.000	0.000	0.000	133	134	135	136	137	138			
21	HLLV	2664.130	0.000	0.000	0.000	0.000	0.000	139	140	141	142	143	144			
22	HLLV	2758.470	0.000	0.000	0.000	0.000	0.000	145	146	147	148	149	150			
23	HLLV	2852.800	0.000	0.000	0.000	0.000	0.000	151	152	153	154	155	156			
70	FWD ATTACH ASRM +Y	2990.675	165.600	0.000	0.000	0.000	0.000	595	596	597	0	0	0			
24	HLLV	2963.420	0.000	0.000	0.000	0.000	0.000	157	158	159	160	161	162			
60	HLLV	2990.670	165.600	0.000	0.000	0.000	0.000	163	164	165	166	167	168			
80	LO2 SLOSH	2963.420	0.001	0.000	0.000	0.000	0.000	169	0	0	0	0	0			

25	HLLV	2990.670	0.000	0.000	170	171	172	173	174	175
26	HLLV	3012.520	0.000	0.000	176	177	178	179	180	181
61	HLLV	2990.670	-165.600	0.000	182	183	184	185	186	187
27	HLLV	3123.150	0.000	0.000	188	189	190	191	192	193
71	FWD ATTACH ASRM -Y	2990.675	-165.600	0.000	598	599	600	0	0	0
28	HLLV	3233.630	0.000	0.000	194	195	196	197	198	199
29	HLLV	3337.350	0.000	0.000	200	201	202	203	204	205
30	HLLV	3480.570	0.000	0.000	206	207	208	209	210	211
31	HLLV	3623.800	0.000	0.000	212	213	214	215	216	217
32	HLLV	3747.400	0.000	0.000	218	219	220	221	222	223
33	HLLV	3871.000	0.000	0.000	224	225	226	227	228	229
72	AFT ATTACH +Y (UPR)	4054.000	161.751	57.000	0	601	602	0	0	0
74	AFT ATTACH +Y (LWR)	4054.000	161.751	-57.000	0	603	604	0	0	0
34	HLLV	3964.500	0.000	0.000	230	231	232	233	234	235
62	HLLV	4054.000	161.750	57.000	236	237	238	239	240	241
64	HLLV	4054.000	161.750	-57.000	242	243	244	245	246	247
35	HLLV	4054.000	0.000	0.000	248	249	250	251	252	253
36	HLLV	4118.650	0.000	0.000	254	255	256	257	258	259
63	HLLV	4054.000	-161.750	57.000	260	261	262	263	264	265
65	HLLV	4054.000	-161.750	-57.000	266	267	268	269	270	271
37	HLLV	4122.650	0.000	0.000	272	273	274	275	276	277
73	AFT ATTACH -Y (UPR)	4054.000	-161.751	57.000	0	605	606	0	0	0
75	AFT ATTACH -Y (LWR)	4054.000	-161.751	-57.000	0	607	608	0	0	0
38	HLLV	4233.270	0.000	0.000	278	279	280	281	282	283
81	LH2 SLOSH	4233.270	0.001	0.000	284	0	0	0	0	0
39	HLLV	4309.400	0.000	0.000	285	286	287	288	289	290
43	HLLV	4388.280	-117.097	117.097	291	292	293	294	295	296
40	HLLV	4385.500	0.000	0.000	297	298	299	300	301	302
41	HLLV	4388.280	-117.097	-117.097	303	304	305	306	307	308
42	HLLV	4388.280	117.097	-117.097	309	310	311	312	313	314
44	HLLV	4388.280	117.097	117.097	315	316	317	318	319	320
999999	CANTILEVER MODES	0.000	0.000	0.000	321	322	323	324	325	326
999999	CANTILEVER MODES	0.000	0.000	0.000	327	328	329	330	331	332
999999	CANTILEVER MODES	0.000	0.000	0.000	333	334	335	336	337	338
999999	CANTILEVER MODES	0.000	0.000	0.000	339	340	341	342	343	344
999999	CANTILEVER MODES	0.000	0.000	0.000	345	346	347	348	349	350
999999	CANTILEVER MODES	0.000	0.000	0.000	351	352	353	354	355	356
999999	CANTILEVER MODES	0.000	0.000	0.000	357	358	359	360	361	362
999999	CANTILEVER MODES	0.000	0.000	0.000	363	364	365	366	367	368
999999	CANTILEVER MODES	0.000	0.000	0.000	369	370	371	372	373	374

999999	CANTILEVER MODES	0.000	0.000	0.000	0.000	375	376	377	378	379	380
999999	CANTILEVER MODES	0.000	0.000	0.000	0.000	381	382	383	384	385	386
999999	CANTILEVER MODES	0.000	0.000	0.000	0.000	387	388	389	390	391	392
999999	CANTILEVER MODES	0.000	0.000	0.000	0.000	393	394	395	396	397	398
999999	CANTILEVER MODES	0.000	0.000	0.000	0.000	399	400	401	402	403	404
999999	CANTILEVER MODES	0.000	0.000	0.000	0.000	405	406	407	408	409	0
1903	FRUSTUM (302)	2873.000	240.350	0.000	0.000	0	410	411	0	0	0
1904	FWD PRESS PT. 20409	3074.980	315.100	0.000	0.000	412	0	0	0	0	0
1904	FWD PRESS PT. 20413	3074.980	240.350	-74.750	0.000	413	0	0	0	0	0
1904	FWD PRESS PT. 20405	3074.980	240.350	74.750	0.000	414	0	0	0	0	0
1904	FWD PRESS PT. 20401	3074.980	165.600	0.000	0.000	415	0	0	0	0	0
1909	STA. X = 851.48 UPR	3394.480	240.350	74.750	0.000	0	0	416	0	0	0
1907	STA. X = 851.48 INB	3394.480	165.600	0.000	0.000	0	417	0	0	0	0
1911	STA. X =1385.46 INB	3928.460	315.100	0.000	0.000	0	418	0	0	0	0
1913	STA. X =1385.46 UPR	3928.460	240.350	74.750	0.000	0	0	419	0	0	0
1917	STA. X =1830.00 UPR	4373.000	240.350	73.620	0.000	0	0	420	0	0	0
1915	STA. X =1830.00 INB	4373.000	166.730	0.000	0.000	0	421	0	0	0	0
1922	AFT PRESS PT. 51613	4416.520	240.350	-51.750	0.000	422	0	0	0	0	0
1922	AFT PRESS PT. 51609	4416.520	292.100	0.000	0.000	423	0	0	0	0	0
1922	AFT PRESS PT. 51605	4416.520	240.350	51.750	0.000	424	0	0	0	0	0
1922	AFT PRESS PT. 51601	4416.520	188.600	0.000	0.000	425	0	0	0	0	0
1919	NOZZLE MOTOR 51600	4406.060	240.354	0.000	0.000	426	427	428	0	0	0
1919	NOZZLE FLEX 51599	4406.060	240.355	0.000	0.000	429	430	431	0	0	0
1920	NOZZLE C.G.	4417.260	240.350	0.000	0.000	0	432	433	0	0	0
1940	SRB LAUNCH PAD POST 4	4482.953	304.300	-93.184	0.000	434	435	436	437	438	439
1941	SRB LAUNCH PAD POST 3	4482.953	196.700	-93.184	0.000	440	441	442	443	444	445
1942	SRB LAUNCH PAD POST 1	4482.953	196.700	93.184	0.000	446	447	448	449	450	451
1943	SRB LAUNCH PAD POST 2	4482.953	304.300	93.184	0.000	452	453	454	455	456	457
999999	CANTILEVER MODES	0.000	0.000	0.000	0.000	458	459	460	461	462	463
999999	CANTILEVER MODES	0.000	0.000	0.000	0.000	464	465	466	467	468	469
999999	CANTILEVER MODES	0.000	0.000	0.000	0.000	470	471	472	473	474	475
999999	CANTILEVER MODES	0.000	0.000	0.000	0.000	476	477	478	479	480	481
999999	CANTILEVER MODES	0.000	0.000	0.000	0.000	482	483	484	485	486	487
999999	CANTILEVER MODES	0.000	0.000	0.000	0.000	488	489	490	491	492	493
999999	CANTILEVER MODES	0.000	0.000	0.000	0.000	494	495	496	497	498	499
999999	CANTILEVER MODES	0.000	0.000	0.000	0.000	500	501	502	503	504	505
999999	CANTILEVER MODES	0.000	0.000	0.000	0.000	506	507	508	509	510	511
999999	CANTILEVER MODES	0.000	0.000	0.000	0.000	512	513	514	515	516	517
999999	CANTILEVER MODES	0.000	0.000	0.000	0.000	518	519	520	521	522	523
999999	CANTILEVER MODES	0.000	0.000	0.000	0.000	524	525	526	527	528	529

Item ID	Description	530	531	532	533	534	535
9999999	CANTILEVER MODES	0.000	0.000	0.000	0.000	0.000	0.000
9999999	CANTILEVER MODES	0.000	0.000	0.000	0.000	0.000	0.000
9999999	CANTILEVER MODES	0.000	0.000	0.000	0.000	0.000	0.000
1953	FRUSTUM	2873.000	-240.351	-240.351	0.000	0.000	0.000
1954	FWD PRESS PT. 20409	3074.980	-315.100	-315.100	0.001	0.000	0.000
1954	FWD PRESS PT. 20413	3074.980	-240.351	-240.351	-74.750	0.000	0.000
1954	FWD PRESS PT. 20405	3074.980	-240.351	-240.351	74.750	0.000	0.000
1954	FWD PRESS PT. 20401	3074.980	-165.600	-165.600	0.001	0.000	0.000
1959	STA. X = 851.48 UPR	3394.480	-240.351	-240.351	74.750	0.000	0.000
1957	STA. X = 851.48 INB	3394.480	-165.600	-165.600	0.000	0.000	0.000
1961	STA. X =1385.46 INB	3928.460	-315.100	-315.100	0.000	0.000	0.000
1963	STA. X =1385.46 UPR	3928.460	-240.351	-240.351	74.750	0.000	0.000
1967	STA. X =1823.85 UPR	4373.000	-240.351	-240.351	73.620	0.000	0.000
1965	STA. X =1823.85 INB	4373.000	-166.730	-166.730	0.000	0.000	0.000
1972	AFT PRESS PT. 51613	4416.520	-240.351	-240.351	-51.750	0.000	0.000
1972	AFT PRESS PT. 51609	4416.520	-292.100	-292.100	0.001	0.000	0.000
1972	AFT PRESS PT. 51605	4416.520	-240.351	-240.351	51.750	0.000	0.000
1972	AFT PRESS PT. 51601	4416.520	-188.600	-188.600	0.001	0.000	0.000
1969	NOZZLE MOTOR 51600	4406.060	-240.351	-240.351	0.000	0.000	0.000
1969	NOZZLE FLEX 51599	4406.060	-240.352	-240.352	0.000	0.000	0.000
1970	NOZZLE C.G.	4417.260	-240.353	-240.353	0.000	0.000	0.000
1990	SRB LAUNCH PAD POST 8	4482.953	-304.300	-304.300	-93.184	571	572
1991	SRB LAUNCH PAD POST 7	4482.953	-196.700	-196.700	-93.184	577	578
1992	SRB LAUNCH PAD POST 5	4482.953	-196.700	-196.700	93.184	583	584
1993	SRB LAUNCH PAD POST 6	4482.953	-304.300	-304.300	93.184	589	590

0000000000000000

\$
 \$ HLLV MODEL 9/11/91
 \$

CELAS2	301	1.73E+6	60	1	70	1	
CELAS2	302	2.34E+6	60	2	70	2	
CELAS2	303	1.12E+4	60	3	70	3	
CELAS2	304	1.73E+6	61	1	71	1	
CELAS2	305	2.34E+6	61	2	71	2	
CELAS2	306	1.12E+4	61	3	71	3	
CELAS2	307	8.08E+5	62	2	72	2	
CELAS2	308	7.65E+4	62	3	72	3	
CELAS2	309	8.08E+5	63	2	73	2	
CELAS2	310	7.65E+4	63	3	73	3	
CELAS2	311	8.08E+5	64	2	74	2	
CELAS2	312	7.65E+4	64	3	74	3	
CELAS2	313	8.08E+5	65	2	75	2	
CELAS2	314	7.65E+4	65	3	75	3	
\$CELAS2	315	9.99E+9	90	1	89	1	
\$CELAS2	316	9.99E+9	90	2	89	2	
\$CELAS2	317	9.99E+9	90	3	89	3	
\$CELAS2	318	9.99E+9	90	4	89	4	
\$CELAS2	319	9.99E+9	90	5	89	5	
\$CELAS2	320	9.99E+9	90	6	89	6	
CELAS2	321	1.12E+6	24	1	80	1	
CELAS2	322	5.13E+5	38	1	81	1	
CBAR	101	100	1	2	99		2
CBAR	102	101	2	3	99		2
CBAR	103	102	3	4	99		2
CBAR	104	103	4	5	99		2
CBAR	105	1001	5	6	99		2
CBAR	106	1001	6	7	99		2
CBAR	107	1001	7	8	99		2
CBAR	108	1001	8	9	99		2
CBAR	109	1001	9	90	99		2
CBAR	110	1001	90	10	99		2
CBAR	111	1001	10	11	99		2
CBAR	112	1001	11	12	99		2
CBAR	113	1001	12	13	99		2
CBAR	114	1001	13	14	99		2
CBAR	115	1002	14	15	99		2
CBAR	116	1002	15	16	99		2
CBAR	117	1002	16	17	99		2
CBAR	118	1002	17	18	99		2
CBAR	119	1002	18	19	99		2
CBAR	120	1003	19	20	99		2
CBAR	121	1004	20	21	99		2
CBAR	122	1004	21	22	99		2
CBAR	123	1003	22	23	99		2
CBAR	124	1002	23	24	99		2
CBAR	125	1005	24	25	99		2
CBAR	126	1006	25	26	99		2
CBAR	127	1012	26	27	99		2
CBAR	128	1012	27	28	99		2
CBAR	129	1012	28	29	99		2
CBAR	130	1013	29	30	99		2
CBAR	131	1013	30	31	99		2
CBAR	132	1014	31	32	99		2

CBAR	133	1014	32	33	99	2
CBAR	134	1015	33	34	99	2
CBAR	135	1015	34	35	99	2
CBAR	136	1015	35	36	99	2
CBAR	137	1015	36	37	99	2
CBAR	138	1015	37	38	99	2
CBAR	139	1015	38	39	99	2
CBAR	140	1015	39	40	99	2
CBAR	141	1020	40	41	1	2
CBAR	142	1020	40	42	1	2
CBAR	143	1020	40	43	1	2
CBAR	144	1020	40	44	1	2
CBAR	200	1020	25	60	1	2
CBAR	201	1020	25	61	1	2
CBAR	202	1020	35	62	1	2
CBAR	203	1020	35	63	1	2
CBAR	204	1020	35	64	1	2
CBAR	205	1020	35	65	1	2
CBAR	301	1020	5	45	99	2
CBAR	302	1020	15	46	99	2

\$

\$ STRUCTURE WTS.

\$

CONM2	3001	1	20.000	AA1
+A1	3.6+06			
CONM2	3002	2	277.80	AA2
+A2	3.6+06			
CONM2	3003	3	507.70	AA3
+A3	3.6+06			
CONM2	3004	4	995.50	AA4
+A4	3.6+06			
CONM2	3005	5	1734.3	AA5
+A5	1.25+07			
CONM2	3006	6	1734.3	AA6
+A6	1.25+07			
\$CONM2	3007	7	1734.3	AA7
CONM2	3008	8	1734.3	AA8
+A8	1.25+07			
CONM2	3009	9	1734.3	AA9
+A9	1.25+07			
\$CONM2	3090	90	1734.3	AA90
CONM2	3010	10	1734.3	AA10
+A10	1.25+07			
CONM2	3011	11	1734.3	AA11
+A11	1.25+07			
\$CONM2	3012	12	1734.3	AA12
CONM2	3013	13	1734.3	AA13
+A13	1.25+07			
CONM2	3014	14	1734.3	AA14
+A14	1.25+07			
CONM2	3015	15	8869.3	AA15
+A15	9.31+07			
CONM2	3016	16	1128.0	AA16
+A16	2.31+07			
CONM2	3017	17	1128.0	AA17
+A17	2.31+07			

\$

\$ LH2 AND LO2 LUMPED MASSES FOR THE X-DIR (AXIAL SLOSH)

\$
 CONM1 3080 80 1048918.
 CONM1 3081 81 210858.9

\$ LO2 TANK MASSES IN Y,Z DIRECTIONS WITH PARTIAL X-DIR

\$
 CONM1 3018 18 58839.8 208685.2 A18
 +18 208685.2 6.77+07
 CONM1 3019 19 57711.7 207557.2 A19
 +19 207557.2 4.46+07
 CONM1 3020 20 57711.7 207557.2 A20
 +20 207557.2 4.46+07
 CONM1 3021 21 57711.7 207557.2 A21
 +21 207557.2 4.46+07
 CONM1 3022 22 57711.7 207557.2 A22
 +22 207557.2 4.46+07
 CONM1 3023 23 61031.8 210877.2 A23
 +23 210877.2 11.2+07
 CONM1 3024 24 61031.8 210877.2 A24
 +24 210877.2 11.2+07

\$ INNER TANK

CONM2 3025 25 3903.33 AA25
 +A25 6.72+07

\$ LH2 TANK MASSES IN Y,Z DIRECTIONS WITH PARTIAL X-DIR

\$
 CONM1 3026 26 10007.0 26226.9 A26
 +26 26226.9 1.4+08
 CONM1 3027 27 10007.0 26226.9 A27
 +27 26226.9 1.4+08
 CONM1 3028 28 6687.0 22906.9 A28
 +28 22906.9 7.28+07
 CONM1 3029 29 6687.0 22906.9 A29
 +29 22906.9 7.28+07
 CONM1 3030 30 6687.0 22906.9 A30
 +30 22906.9 7.28+07
 CONM1 3031 31 6687.0 22906.9 A31
 +31 22906.9 7.28+07
 CONM1 3032 32 6687.0 22906.9 A32
 +32 22906.9 7.28+07
 CONM1 3033 33 6687.0 22906.9 A33
 +33 22906.9 7.28+07
 CONM1 3034 34 6687.0 22906.9 A34
 +34 22906.9 7.28+07
 CONM1 3035 35 6687.0 22906.9 A35
 +35 22906.9 7.28+07
 CONM1 3036 36 7348.4 23568.3 A36
 +36 23568.3 9.46+07
 CONM1 3037 37 7348.4 23568.3 A37
 +37 23568.3 9.46+07
 CONM1 3038 38 7348.4 23568.3 A38
 +38 23568.3 9.46+07

\$ ENGINES AND AFT STRUCTURE
 \$

CONM2	3039	39		29200.5					AB39
+B39	2.18+07								
CONM2	3040	40		29200.5					AB40
+B40	2.18+07								
CONM2	3041	41		8004.0					AB1
+B1	7.06+6		1.95+7			1.98+7			
CONM2	3042	42		8004.0					AB2
+B2	7.06+6		1.95+7			1.98+7			
CONM2	3043	43		8004.0					AE3
+B3	7.06+6		1.95+7			1.98+7			
CONM2	3044	44		8004.0					AB4
+B4	7.06+6		1.95+7			1.98+7			
CONM2	3060	60		50.					
CONM2	3061	61		50.					
CONM2	3062	62		50.					
CONM2	3063	63		50.					
CONM2	3064	64		50.					
CONM2	3065	65		50.					
CONM2	3070	70		1.0					
CONM2	3071	71		1.0					
CONM2	3072	72		1.0					
CONM2	3073	73		1.0					
CONM2	3074	74		1.0					
CONM2	3075	75		1.0					
\$									
\$	FORWARD PROPULSION MODULE (FPM)								
\$									
CONM2	3045	45		3429.0					AB5
+B5	3.09+6		3.09+6			3.09+6			
\$									
\$	CARGO TRANSFER VEHICLE (CTV)								
\$									
CONM2	3046	46		17905.0					AB6
+B6	4.02+7		2.8+09			2.8+09			
\$									
\$	PAYLOAD WT.								
\$									
CONM2	3007	7		31734.3					AB7
+B7	9.39+7		6.66+8			6.75+8			
CONM2	3090	90		41734.3					AB90
+B90	9.39+7		6.66+8			6.75+8			
CONM2	3012	12		31734.3					AB12
+B12	9.39+7		6.66+8			6.75+8			
EIGR	40	FEER	0.1			15	1.-4		+EIG1
+EIG1	MAX								
EIGR	42	INV	0.0	100.	60	8	1.-5		+EIG2
+EIG2	MAX								
EIGR	41	GIV				12	1.-4		+EIGR
+EIGR	MAX								
GRID	1		1066.06	0.0	0.0				
GRID	2		1110.6	0.0	0.0				
GRID	3		1155.10	0.0	0.0				
GRID	4		1229.75	0.0	0.0				
GRID	5		1304.4	0.0	0.0				
GRID	6		1411.0	0.0	0.0				
GRID	7		1518.0	0.0	0.0				
GRID	8		1625.0	0.0	0.0				

GRID	9	1732.0	0.0	0.0
GRID	10	1839.0	0.0	0.0
GRID	11	1946.0	0.0	0.0
GRID	12	2050.8	0.0	0.0
GRID	13	2160.0	0.0	0.0
GRID	14	2264.4	0.0	0.0
GRID	15	2284.8	0.0	0.0
GRID	16	2340.68	0.0	0.0
GRID	17	2396.57	0.0	0.0
GRID	18	2459.1750.0		0.0
GRID	19	2473.8	0.0	0.0
GRID	20	2569.8	0.0	0.0
GRID	21	2664.1330.0		0.0
GRID	22	2758.4670.0		0.0
GRID	23	2852.8	0.0	0.0
GRID	24	2963.4250.0		0.0
GRID	25	2990.6750.0		0.0
GRID	26	3012.5250.0		0.0
GRID	27	3123.15	0.0	0.0
GRID	28	3233.6250.0		0.0
GRID	29	3337.35	0.0	0.0
GRID	30	3480.5750.0		0.0
GRID	31	3623.8	0.0	0.0
GRID	32	3747.4	0.0	0.0
GRID	33	3871.0	0.0	0.0
GRID	34	3964.5	0.0	0.0
GRID	35	4054.0	0.0	0.0
GRID	36	4118.65	0.0	0.0
GRID	37	4122.65	0.0	0.0
GRID	38	4233.2750.0		0.0
GRID	39	4309.4	0.0	0.0
GRID	40	4385.5	0.0	0.0
GRID	41	4388.28	-117.097	-117.097
GRID	42	4388.28	117.097	-117.097
GRID	43	4388.28	-117.097	117.097
GRID	44	4388.28	117.097	117.097
GRID	45	1274.00	0.0	0.0
GRID	46	2342.00	0.0	0.0
GRID	60	2990.675	165.60	0.0
GRID	61	2990.675	-165.60	0.0
GRID	62	4054.0	161.75	57.0
GRID	63	4054.0	-161.75	57.0
GRID	64	4054.0	161.75	-57.0
GRID	65	4054.0	-161.75	-57.0
GRID	70	2990.675	165.60	0.0
GRID	71	2990.675	-165.60	0.0
GRID	72	4054.0	161.75	57.0
GRID	73	4054.0	-161.75	57.0
GRID	74	4054.0	161.75	-57.0
GRID	75	4054.0	-161.75	-57.0
GRID	80	2963.4250.0		0.0
GRID	81	4233.2750.0		0.0
\$GRID	89	1888.14	0.0	0.0
GRID	90	1784.4	0.0	0.0
GRID	99	4687.06	1.0	0.0

123456

\$

\$ ALUMINUM MATERIAL

```

$
MAT1      2001      9.9+6                .33      0.0
PARAM     GRDPNT    0
$PARAM    AUTOSPC  1
PARAM     WTMASS   2.591E-3
$
$  CONE BAR PROPERTIES
$
PBAR      100      2001      17.9      3433.0  3433.0  6866.0
PBAR      101      2001      30.7      32566.  32566.  65132.
PBAR      102      2001      36.0      60000.  60000.  .12E+6
PBAR      103      2001      50.6      .214E+6 .214E+6 .43E+6
$
$  SHROUD BAR PROPERTIES
$
PBAR      1001     2001      170.5     1.05E+6 .656E+6 1.71E+6
$
$  LO2 TANK BAR PROPERTIES
$
PBAR      1002     2001      254.65    4.18E+6 2.79E+6 7.08E+6
PBAR      1003     2001      237.18    3.79E+6 2.69E+6 5.91E+6
PBAR      1004     2001      216.425   3.33E+6 2.60E+6 6.42E+6
PBAR      1005     2001      263.83    4.51E+6 2.72E+6 4.99E+6
PBAR      1006     2001      263.79    4.66E+6 2.41E+6 4.99E+6
$
$  LH2 TANK BAR PROPERTIES
$
PBAR      1012     2001      145.06    1.99E+6 1.99E+6 2.54E+6
PBAR      1013     2001      196.984   2.68E+6 2.71E+6 2.43E+6
PBAR      1014     2001      225.198   3.07E+6 3.09E+6 2.34E+6
PBAR      1015     2001      213.168   2.97E+6 2.87E+6 2.31E+6
PBAR      1020     2001      50.0      9.99E+9 9.99E+9 9.99E+9
$SPC1     100      123      42        43        44        45
SPC1      100      456      70        71        72        73
SPC1      100      456      74        75
SPC1      100      1        72        73        74        75
SPC1      100      23456    80        81
$SPC1     100      3        74        75
$$$$$$$$$$$$$FIXED SRB'S $$$$$$$$$$$$$$$$
$SPC1     100      123      70        71
$SPC1     100      2        72        73        74        75
$SPC1     100      3        72        73
$
$  AXIS DIRECTION INDICATORS
$
$
GRID      50000      0.0      0.0      0.0      123456
GRID      50001      10.0     0.0      0.0      123456
GRID      50002      0.0      10.0     0.0      123456
GRID      50003      0.0      0.0      10.0     123456
PLOTTEL   55001      50000    50001
PLOTTEL   55002      50000    50002
PLOTTEL   55003      50000    50003

```

```

*****
*FRED HARRINGTON * MARSHALL SPACE FLIGHT CENTER *
* * * * * SYSTEMS DYNAMICS DIVISION *
* * * * * STAGE 1.5,FULL, LIFTOFF MODEL *
* * * * * 12/03/91 *
*****
DOFS = 1388 BND DOFS = 0 INT DOFS = 0

```

NODE	DESCRIPTION	X COORD			Y COORD			Z COORD			ROW/COL OF MATRIX					
		X	Y	Z	X	Y	Z	X	Y	Z	X	Y	Z	RX	RY	RZ
809	FULL1*5	4385.500	0.000	-165.463	0.000	0.000	-165.463	1	2	3	4	5	6			
810	FULL1*5	4385.500	-63.320	-152.868	-63.320	-152.868	-152.868	7	8	9	10	11	12			
811	FULL1*5	4385.500	-117.000	-117.000	-117.000	-117.000	-117.000	13	14	15	16	17	18			
808	FULL1*5	4385.500	63.320	-152.868	63.320	-152.868	-152.868	19	20	21	22	23	24			
807	FULL1*5	4385.500	117.000	-117.000	117.000	-117.000	-117.000	25	26	27	28	29	30			
812	FULL1*5	4385.500	-152.868	-63.320	-152.868	-63.320	-63.320	31	32	33	34	35	36			
813	FULL1*5	4385.500	-165.463	0.000	-165.463	0.000	0.000	37	38	39	40	41	42			
806	FULL1*5	4385.500	152.868	-63.320	152.868	-63.320	-63.320	43	44	45	46	47	48			
814	FULL1*5	4385.500	-152.868	63.320	-152.868	63.320	63.320	49	50	51	52	53	54			
805	FULL1*5	4385.500	165.463	0.000	165.463	0.000	0.000	55	56	57	58	59	60			
815	FULL1*5	4385.500	-117.000	117.000	-117.000	117.000	117.000	61	62	63	64	65	66			
804	FULL1*5	4385.500	152.868	63.320	152.868	63.320	63.320	67	68	69	70	71	72			
816	FULL1*5	4385.500	-63.320	152.868	-63.320	152.868	152.868	73	74	75	76	77	78			
803	FULL1*5	4385.500	117.000	117.000	117.000	117.000	117.000	79	80	81	82	83	84			
801	FULL1*5	4385.500	0.000	165.463	0.000	165.463	165.463	85	86	87	88	89	90			
802	FULL1*5	4385.500	63.320	152.868	63.320	152.868	152.868	91	92	93	94	95	96			
860	FULL1*5	4385.500	-26.405	-63.748	-26.405	-63.748	-63.748	97	98	99	100	101	102			
710	FULL1*5	4341.570	-63.320	-152.868	-63.320	-152.868	-152.868	103	104	105	106	107	108			
859	FULL1*5	4385.500	0.000	-69.000	0.000	-69.000	-69.000	109	110	111	112	113	114			
709	FULL1*5	4341.570	0.000	-165.463	0.000	-165.463	-165.463	115	116	117	118	119	120			
858	FULL1*5	4385.500	26.405	-63.748	26.405	-63.748	-63.748	121	122	123	124	125	126			
708	FULL1*5	4341.570	63.320	-152.868	63.320	-152.868	-152.868	127	128	129	130	131	132			
861	FULL1*5	4385.500	-48.791	-48.791	-48.791	-48.791	-48.791	133	134	135	136	137	138			
711	FULL1*5	4341.570	-117.000	-117.000	-117.000	-117.000	-117.000	139	140	141	142	143	144			
862	FULL1*5	4385.500	-63.748	-26.405	-63.748	-26.405	-26.405	145	146	147	148	149	150			
712	FULL1*5	4341.570	-152.868	-63.320	-152.868	-63.320	-63.320	151	152	153	154	155	156			
863	FULL1*5	4385.500	-69.000	0.000	-69.000	0.000	0.000	157	158	159	160	161	162			
864	FULL1*5	4385.500	-63.748	26.405	-63.748	26.405	26.405	163	164	165	166	167	168			
865	FULL1*5	4385.500	-48.791	48.791	-48.791	48.791	48.791	169	170	171	172	173	174			

866 FULL1*5	4385.500	-26.405	63.748	175	176	177	178	179	180
857 FULL1*5	4385.500	48.791	-48.791	181	182	183	184	185	186
707 FULL1*5	4341.570	117.000	-117.000	187	188	189	190	191	192
856 FULL1*5	4385.500	63.748	-26.405	193	194	195	196	197	198
706 FULL1*5	4341.570	152.868	-63.320	199	200	201	202	203	204
855 FULL1*5	4385.500	69.000	0.000	205	206	207	208	209	210
713 FULL1*5	4341.570	-165.463	0.000	211	212	213	214	215	216
714 FULL1*5	4341.570	-152.868	63.320	217	218	219	220	221	222
705 FULL1*5	4341.570	165.463	0.000	223	224	225	226	227	228
715 FULL1*5	4341.570	-117.000	117.000	229	230	231	232	233	234
704 FULL1*5	4341.570	152.868	63.320	235	236	237	238	239	240
716 FULL1*5	4341.570	-63.320	152.868	241	242	243	244	245	246
703 FULL1*5	4341.570	117.000	117.000	247	248	249	250	251	252
701 FULL1*5	4341.570	0.000	165.463	253	254	255	256	257	258
702 FULL1*5	4341.570	63.320	152.868	259	260	261	262	263	264
854 FULL1*5	4385.500	63.748	26.405	265	266	267	268	269	270
853 FULL1*5	4385.500	48.791	48.791	271	272	273	274	275	276
852 FULL1*5	4385.500	26.405	63.748	277	278	279	280	281	282
851 FULL1*5	4385.500	0.000	69.000	283	284	285	286	287	288
761 FULL1*5	4341.570	-65.894	-65.894	289	290	291	292	293	294
611 FULL1*5	4297.820	-117.000	-117.000	295	296	297	298	299	300
760 FULL1*5	4341.570	-35.662	-86.095	301	302	303	304	305	306
610 FULL1*5	4297.820	-63.320	-152.868	307	308	309	310	311	312
759 FULL1*5	4341.570	0.000	-93.188	313	314	315	316	317	318
609 FULL1*5	4297.820	0.000	-165.463	319	320	321	322	323	324
758 FULL1*5	4341.570	35.662	-86.095	325	326	327	328	329	330
608 FULL1*5	4297.820	63.320	-152.868	331	332	333	334	335	336
757 FULL1*5	4341.570	65.894	-65.894	337	338	339	340	341	342
607 FULL1*5	4297.820	117.000	-117.000	343	344	345	346	347	348
762 FULL1*5	4341.570	-86.095	-35.662	349	350	351	352	353	354
612 FULL1*5	4297.820	-152.868	-63.320	355	356	357	358	359	360
763 FULL1*5	4341.570	-93.188	0.000	361	362	363	364	365	366
613 FULL1*5	4297.820	-165.463	0.000	367	368	369	370	371	372
764 FULL1*5	4341.570	-86.095	35.662	373	374	375	376	377	378
765 FULL1*5	4341.570	-65.894	65.894	379	380	381	382	383	384
766 FULL1*5	4341.570	-35.662	86.095	385	386	387	388	389	390
756 FULL1*5	4341.570	86.095	-35.662	391	392	393	394	395	396
606 FULL1*5	4297.820	152.868	-63.320	397	398	399	400	401	402
755 FULL1*5	4341.570	93.188	0.000	403	404	405	406	407	408

605 FULL1*5	4297.820	165.463	0.000	409	410	411	412	413	414
754 FULL1*5	4341.570	86.095	35.662	415	416	417	418	419	420
614 FULL1*5	4297.820	-152.868	63.320	421	422	423	424	425	426
615 FULL1*5	4297.820	-117.000	117.000	427	428	429	430	431	432
604 FULL1*5	4297.820	152.868	63.320	433	434	435	436	437	438
616 FULL1*5	4297.820	-63.320	152.868	439	440	441	442	443	444
603 FULL1*5	4297.820	117.000	117.000	445	446	447	448	449	450
601 FULL1*5	4297.820	0.000	165.463	451	452	453	454	455	456
602 FULL1*5	4297.820	63.320	152.868	457	458	459	460	461	462
753 FULL1*5	4341.570	65.894	65.894	463	464	465	466	467	468
752 FULL1*5	4341.570	35.662	86.095	469	470	471	472	473	474
751 FULL1*5	4341.570	0.000	93.188	475	476	477	478	479	480
662 FULL1*5	4297.820	-108.352	-44.881	481	482	483	484	485	486
512 FULL1*5	4254.070	-152.868	-63.320	487	488	489	490	491	492
661 FULL1*5	4297.820	-82.929	-82.929	493	494	495	496	497	498
511 FULL1*5	4254.070	-117.000	-117.000	499	500	501	502	503	504
660 FULL1*5	4297.820	-44.881	-108.352	505	506	507	508	509	510
510 FULL1*5	4254.070	-63.320	-152.868	511	512	513	514	515	516
659 FULL1*5	4297.820	0.000	-117.280	517	518	519	520	521	522
509 FULL1*5	4254.070	0.000	-165.463	523	524	525	526	527	528
658 FULL1*5	4297.820	44.881	-108.352	529	530	531	532	533	534
508 FULL1*5	4254.070	63.320	-152.868	535	536	537	538	539	540
657 FULL1*5	4297.820	82.929	-82.929	541	542	543	544	545	546
507 FULL1*5	4254.070	117.000	-117.000	547	548	549	550	551	552
656 FULL1*5	4297.820	108.352	-44.881	553	554	555	556	557	558
506 FULL1*5	4254.070	152.868	-63.320	559	560	561	562	563	564
663 FULL1*5	4297.820	-117.280	0.000	565	566	567	568	569	570
513 FULL1*5	4254.070	-165.463	0.000	571	572	573	574	575	576
664 FULL1*5	4297.820	-108.352	44.881	577	578	579	580	581	582
514 FULL1*5	4254.070	-152.868	63.320	583	584	585	586	587	588
665 FULL1*5	4297.820	-82.929	82.929	589	590	591	592	593	594
666 FULL1*5	4297.820	-44.881	108.352	595	596	597	598	599	600
655 FULL1*5	4297.820	117.280	0.000	601	602	603	604	605	606
505 FULL1*5	4254.070	165.463	0.000	607	608	609	610	611	612
654 FULL1*5	4297.820	108.352	44.881	613	614	615	616	617	618
504 FULL1*5	4254.070	152.868	63.320	619	620	621	622	623	624
653 FULL1*5	4297.820	82.929	82.929	625	626	627	628	629	630
515 FULL1*5	4254.070	-117.000	117.000	631	632	633	634	635	636
516 FULL1*5	4254.070	-63.320	152.868	637	638	639	640	641	642

503 FULL1*5	4254.070	117.000	117.000	643	644	645	646	647	648
501 FULL1*5	4254.070	0.000	165.463	649	650	651	652	653	654
502 FULL1*5	4254.070	63.320	152.868	655	656	657	658	659	660
652 FULL1*5	4297.820	44.881	108.352	661	662	663	664	665	666
651 FULL1*5	4297.820	0.000	117.280	667	668	669	670	671	672
563 FULL1*5	4254.070	-141.371	0.000	673	674	675	676	677	678
413 FULL1*5	4227.370	-165.463	0.000	679	680	681	682	683	684
562 FULL1*5	4254.070	-130.610	-54.100	685	686	687	688	689	690
412 FULL1*5	4227.370	-152.868	-63.320	691	692	693	694	695	696
561 FULL1*5	4254.070	-99.965	-99.965	697	698	699	700	701	702
411 FULL1*5	4227.370	-117.000	-117.000	703	704	705	706	707	708
560 FULL1*5	4254.070	-54.100	-130.610	709	710	711	712	713	714
410 FULL1*5	4227.370	-63.320	-152.868	715	716	717	718	719	720
559 FULL1*5	4254.070	0.000	-141.371	721	722	723	724	725	726
409 FULL1*5	4227.370	0.000	-165.463	727	728	729	730	731	732
558 FULL1*5	4254.070	54.100	-130.610	733	734	735	736	737	738
408 FULL1*5	4227.370	63.320	-152.868	739	740	741	742	743	744
557 FULL1*5	4254.070	99.965	-99.965	745	746	747	748	749	750
407 FULL1*5	4227.370	117.000	-117.000	751	752	753	754	755	756
556 FULL1*5	4254.070	130.610	-54.100	757	758	759	760	761	762
406 FULL1*5	4227.370	152.868	-63.320	763	764	765	766	767	768
555 FULL1*5	4254.070	141.371	0.000	769	770	771	772	773	774
405 FULL1*5	4227.370	165.463	0.000	775	776	777	778	779	780
564 FULL1*5	4254.070	-130.610	54.100	781	782	783	784	785	786
414 FULL1*5	4227.370	-152.868	63.320	787	788	789	790	791	792
565 FULL1*5	4254.070	-99.965	99.965	793	794	795	796	797	798
415 FULL1*5	4227.370	-117.000	117.000	799	800	801	802	803	804
566 FULL1*5	4254.070	-54.100	130.610	805	806	807	808	809	810
554 FULL1*5	4254.070	130.610	54.100	811	812	813	814	815	816
404 FULL1*5	4227.370	152.868	63.320	817	818	819	820	821	822
553 FULL1*5	4254.070	99.965	99.965	823	824	825	826	827	828
403 FULL1*5	4227.370	117.000	117.000	829	830	831	832	833	834
552 FULL1*5	4254.070	54.100	130.610	835	836	837	838	839	840
416 FULL1*5	4227.370	-63.320	152.868	841	842	843	844	845	846
401 FULL1*5	4227.370	0.000	165.463	847	848	849	850	851	852
402 FULL1*5	4227.370	63.320	152.868	853	854	855	856	857	858
551 FULL1*5	4254.070	0.000	141.371	859	860	861	862	863	864
314 FULL1*5	4210.320	-152.868	63.320	865	866	867	868	869	870
313 FULL1*5	4210.320	-165.463	0.000	871	872	873	874	875	876

312 FULL1*5	4210.320	-152.868	-63.320	877 878 879 880 881 882
311 FULL1*5	4210.320	-117.000	-117.000	883 884 885 886 887 888
310 FULL1*5	4210.320	-63.320	-152.868	889 890 891 892 893 894
309 FULL1*5	4210.320	0.000	-165.463	895 896 897 898 899 900
308 FULL1*5	4210.320	63.320	-152.868	901 902 903 904 905 906
307 FULL1*5	4210.320	117.000	-117.000	907 908 909 910 911 912
306 FULL1*5	4210.320	152.868	-63.320	913 914 915 916 917 918
305 FULL1*5	4210.320	165.463	0.000	919 920 921 922 923 924
304 FULL1*5	4210.320	152.868	63.320	925 926 927 928 929 930
315 FULL1*5	4210.320	-117.000	117.000	931 932 933 934 935 936
316 FULL1*5	4210.320	-63.320	152.868	937 938 939 940 941 942
303 FULL1*5	4210.320	117.000	117.000	943 944 945 946 947 948
302 FULL1*5	4210.320	63.320	152.868	949 950 951 952 953 954
301 FULL1*5	4210.320	0.000	165.463	955 956 957 958 959 960
215 FULL1*5	4166.570	-117.000	117.000	961 962 963 964 965 966
214 FULL1*5	4166.570	-152.868	63.320	967 968 969 970 971 972
213 FULL1*5	4166.570	-165.463	0.000	973 974 975 976 977 978
212 FULL1*5	4166.570	-152.868	-63.320	979 980 981 982 983 984
211 FULL1*5	4166.570	-117.000	-117.000	985 986 987 988 989 990
210 FULL1*5	4166.570	-63.320	-152.868	991 992 993 994 995 996
209 FULL1*5	4166.570	0.000	-165.463	997 998 999 1000 1001 1002
208 FULL1*5	4166.570	63.320	-152.868	1003 1004 1005 1006 1007 1008
207 FULL1*5	4166.570	117.000	-117.000	1009 1010 1011 1012 1013 1014
206 FULL1*5	4166.570	152.868	-63.320	1015 1016 1017 1018 1019 1020
205 FULL1*5	4166.570	165.463	0.000	1021 1022 1023 1024 1025 1026
204 FULL1*5	4166.570	152.868	63.320	1027 1028 1029 1030 1031 1032
203 FULL1*5	4166.570	117.000	117.000	1033 1034 1035 1036 1037 1038
216 FULL1*5	4166.570	-63.320	152.868	1039 1040 1041 1042 1043 1044
201 FULL1*5	4166.570	0.000	165.463	1045 1046 1047 1048 1049 1050
202 FULL1*5	4166.570	63.320	152.868	1051 1052 1053 1054 1055 1056
116 FULL1*5	4122.650	-63.320	152.868	1057 1058 1059 1060 1061 1062
115 FULL1*5	4122.650	-117.000	117.000	1063 1064 1065 1066 1067 1068
114 FULL1*5	4122.650	-152.868	63.320	1069 1070 1071 1072 1073 1074
113 FULL1*5	4122.650	-165.463	0.000	1075 1076 1077 1078 1079 1080
112 FULL1*5	4122.650	-152.868	-63.320	1081 1082 1083 1084 1085 1086
111 FULL1*5	4122.650	-117.000	-117.000	1087 1088 1089 1090 1091 1092
110 FULL1*5	4122.650	-63.320	-152.868	1093 1094 1095 1096 1097 1098
109 FULL1*5	4122.650	0.000	-165.463	1099 1100 1101 1102 1103 1104
108 FULL1*5	4122.650	63.320	-152.868	1105 1106 1107 1108 1109 1110

107	FULL1*5	4122.650	117.000	-117.000	1111111211131111411151116
106	FULL1*5	4122.650	152.868	-63.320	111711181119112011211122
105	FULL1*5	4122.650	165.463	0.000	112311241125112611271128
104	FULL1*5	4122.650	152.868	63.320	112911301131113211331134
103	FULL1*5	4122.650	117.000	117.000	113511361137113811391140
102	FULL1*5	4122.650	63.320	152.868	114111421143114411451146
101	FULL1*5	4122.650	0.000	165.463	114711481149115011511152
37	FULL1*5	4122.650	0.000	0.000	115311541155115611571158
38	FULL1*5	4233.270	0.000	0.000	115911601161116211631164
36	FULL1*5	4090.320	0.000	0.000	116511661167116811691170
81	FULL1*5	4233.270	0.000	0.000	1171 0 0 0 0
35	FULL1*5	4058.000	0.000	0.000	117211731174117511761177
34	FULL1*5	3941.140	0.000	0.000	117811791180118111821183
33	FULL1*5	3824.290	0.000	0.000	118411851186118711881189
32	FULL1*5	3707.430	0.000	0.000	119011911192119311941195
31	FULL1*5	3590.570	0.000	0.000	119611971198119912001201
30	FULL1*5	3473.720	0.000	0.000	120212031204120512061207
29	FULL1*5	3356.860	0.000	0.000	120812091210121112121213
28	FULL1*5	3240.010	0.000	0.000	121412151216121712181219
27	FULL1*5	3123.150	0.000	0.000	122012211222122312241225
26	FULL1*5	3012.520	0.000	0.000	122612271228122912301231
25	FULL1*5	2985.670	0.000	0.000	123212331234123512361237
80	FULL1*5	2963.420	0.000	0.000	1238 0 0 0 0
24	FULL1*5	2963.420	0.000	0.000	123912401241124212431244
23	FULL1*5	2852.800	0.000	0.000	124512461247124812491250
22	FULL1*5	2758.470	0.000	0.000	125112521253125412551256
21	FULL1*5	2664.130	0.000	0.000	125712581259126012611262
20	FULL1*5	2569.800	0.000	0.000	126312641265126612671268
19	FULL1*5	2471.150	0.000	0.000	126912701271127212731274
18	FULL1*5	2459.170	0.000	0.000	127512761277127812791280
17	FULL1*5	2410.800	0.000	0.000	128112821283128412851286
16	FULL1*5	2347.800	0.000	0.000	128712881289129012911292
15	FULL1*5	2284.800	0.000	0.000	129312941295129612971298
999	FULL1*5	1997.580	0.000	0.000	129913001301130213031304
14	FULL1*5	2264.400	0.000	0.000	130513061307130813091310
13	FULL1*5	2184.400	0.000	0.000	131113121313131413151316
12	FULL1*5	2104.400	0.000	0.000	131713181319132013211322
11	FULL1*5	2024.400	0.000	0.000	132313241325132613271328
10	FULL1*5	1944.400	0.000	0.000	132913301331133213331334

(

(

(

133513361337133813391340
134113421343134413451346
134713481349135013511352
135313541355135613571358
135913601361136213631364
136513661367136813691370
137113721373137413751376
137713781379138013811382
138313841385138613871388

0.000
0.000
0.000
0.000
0.000
0.000
0.000
0.000
0.000
0.000

0.000
0.000
0.000
0.000
0.000
0.000
0.000
0.000
0.000
0.000

1864.400
1784.400
1704.400
1624.400
1544.400
1494.640
1444.870
1395.100
1306.060

9 FULL1*5
8 FULL1*5
7 FULL1*5
6 FULL1*5
5 FULL1*5
4 FULL1*5
3 FULL1*5
2 FULL1*5
1 FULL1*5

00000000000000000000

NASTRAN BULK DATA DECK FOR NLS2

CELAS2	301	1.73E+6	24	1	80	1	
CELAS2	302	2.34E+6	38	1	81	1	
CBAR	101	1001	1	2	99		2
CBAR	102	1001	2	3	99		2
CBAR	103	1001	3	4	99		2
CBAR	104	1001	4	5	99		2
CBAR	105	1001	5	6	99		2
CBAR	106	1001	6	7	99		2
CBAR	107	1001	7	8	99		2
CBAR	108	1001	8	9	99		2
CBAR	109	1001	9	10	99		2
CBAR	110	1001	10	11	99		2
CBAR	111	1001	11	12	99		2
CBAR	112	1001	12	13	99		2
CBAR	113	1001	13	14	99		2
CBAR	114	1002	14	15	99		2
CBAR	115	1002	15	16	99		2
CBAR	116	1002	16	17	99		2
CBAR	117	1002	17	18	99		2
CBAR	118	1002	18	19	99		2
CBAR	119	1003	19	20	99		2
CBAR	120	1004	20	21	99		2
CBAR	121	1004	21	22	99		2
CBAR	122	1003	22	23	99		2
CBAR	123	1002	23	24	99		2
CBAR	124	1005	24	25	99		2
CBAR	125	1006	25	26	99		2
CBAR	126	1012	26	27	99		2
CBAR	127	1012	27	28	99		2
CBAR	128	1012	28	29	99		2
CBAR	129	1013	29	30	99		2
CBAR	130	1013	30	31	99		2
CBAR	131	1014	31	32	99		2
CBAR	999	1020	999	15	99		2
CBAR	132	1014	32	33	99		2
CBAR	133	1015	33	34	99		2
CBAR	134	1015	34	35	99		2
CBAR	135	1015	35	36	99		2
CBAR	136	1015	36	37	99		2
CBAR	137	1015	37	38	99		2
CBAR	149	1020	101	37	30		2
CBAR	150	1020	102	37	30		2
CBAR	151	1020	103	37	30		2
CBAR	152	1020	104	37	30		2
CBAR	153	1020	105	37	30		2
CBAR	154	1020	106	37	30		2
CBAR	155	1020	107	37	30		2
CBAR	156	1020	108	37	30		2
CBAR	157	1020	109	37	30		2
CBAR	158	1020	110	37	30		2
CBAR	159	1020	111	37	30		2

CBAR	160	1020	112	37	30	2
CBAR	161	1020	113	37	30	2
CBAR	162	1020	114	37	30	2
CBAR	163	1020	115	37	30	2
CBAR	164	1020	116	37	30	2
CBAR	201	2020	101	201	881	2
CBAR	202	2020	201	301	881	2
CBAR	203	2020	301	401	881	2
CBAR	204	2021	401	501	881	2
CBAR	205	2022	501	601	881	2
CBAR	206	2023	601	701	881	2
CBAR	207	2024	701	801	881	2
CBAR	208	2020	103	203	883	2
CBAR	209	2020	203	303	883	2
CBAR	210	2020	303	403	883	2
CBAR	211	2025	403	503	883	2
CBAR	212	2026	503	603	883	2
CBAR	213	2027	603	703	883	2
CBAR	214	2028	703	803	883	2
CBAR	215	2020	105	205	885	2
CBAR	216	2020	205	305	885	2
CBAR	217	2020	305	405	885	2
CBAR	218	2021	405	505	885	2
CBAR	219	2022	505	605	885	2
CBAR	220	2023	605	705	885	2
CBAR	221	2024	705	805	885	2
CBAR	222	2020	107	207	887	2
CBAR	223	2020	207	307	887	2
CBAR	224	2020	307	407	887	2
CBAR	225	2025	407	507	887	2
CBAR	226	2026	507	607	887	2
CBAR	227	2027	607	707	887	2
CBAR	228	2028	707	807	887	2
CBAR	229	2020	109	209	889	2
CBAR	230	2020	209	309	889	2
CBAR	231	2020	309	409	889	2
CBAR	232	2021	409	509	889	2
CBAR	233	2022	509	609	889	2
CBAR	234	2023	609	709	889	2
CBAR	235	2024	709	809	889	2
CBAR	236	2020	111	211	891	2
CBAR	237	2020	211	311	891	2
CBAR	238	2020	311	411	891	2
CBAR	239	2025	411	511	891	2
CBAR	240	2026	511	611	891	2
CBAR	241	2027	611	711	891	2
CBAR	242	2028	711	811	891	2
CBAR	243	2020	113	213	893	2
CBAR	244	2020	213	313	893	2
CBAR	245	2020	313	413	893	2
CBAR	246	2021	413	513	893	2
CBAR	247	2022	513	613	893	2
CBAR	248	2023	613	713	893	2
CBAR	249	2024	713	813	893	2

CBAR	250	2020	115	215	895	2
CBAR	251	2020	215	315	895	2
CBAR	252	2020	315	415	895	2
CBAR	253	2025	415	515	895	2
CBAR	254	2026	515	615	895	2
CBAR	255	2027	615	715	895	2
CBAR	256	2028	715	815	895	2
\$						
\$ INNER CONE STRUCTURE BEAMS						
\$						
CBAR	257	2031	301	551	881	2
CBAR	258	2032	551	651	881	2
CBAR	259	2033	651	751	881	2
CBAR	260	2034	751	851	881	2
CBAR	261	2031	309	559	889	2
CBAR	262	2032	559	659	889	2
CBAR	263	2033	659	759	889	2
CBAR	264	2034	759	859	889	2
\$						
\$ RINGS FOR THRUST STRUCTURE						
\$						
CBAR	265	1101	201	202	102	2
CBAR	266	1101	202	203	103	2
CBAR	267	1101	203	204	104	2
CBAR	268	1101	204	205	105	2
CBAR	269	1101	205	206	106	2
CBAR	270	1101	206	207	107	2
CBAR	271	1101	207	208	108	2
CBAR	272	1101	208	209	109	2
CBAR	273	1101	209	210	110	2
CBAR	274	1101	210	211	111	2
CBAR	275	1101	211	212	112	2
CBAR	276	1101	212	213	113	2
CBAR	277	1101	213	214	114	2
CBAR	278	1101	214	215	115	2
CBAR	279	1101	215	216	116	2
CBAR	280	1101	216	201	101	2
CBAR	281	1103	301	302	102	2
CBAR	282	1103	302	303	103	2
CBAR	283	1103	303	304	104	2
CBAR	284	1103	304	305	105	2
CBAR	285	1103	305	306	106	2
CBAR	286	1103	306	307	107	2
CBAR	287	1103	307	308	108	2
CBAR	288	1103	308	309	109	2
CBAR	289	1103	309	310	110	2
CBAR	290	1103	310	311	111	2
CBAR	291	1103	311	312	112	2
CBAR	292	1103	312	313	113	2
CBAR	293	1103	313	314	114	2
CBAR	294	1103	314	315	115	2
CBAR	295	1103	315	316	116	2
CBAR	296	1103	316	301	101	2
CBAR	297	1102	401	402	102	2

CBAR	298	1102	402	403	103	2
CBAR	299	1102	403	404	104	2
CBAR	300	1102	404	405	105	2
CBAR	301	1102	405	406	106	2
CBAR	302	1102	406	407	107	2
CBAR	303	1102	407	408	108	2
CBAR	304	1102	408	409	109	2
CBAR	305	1102	409	410	110	2
CBAR	306	1102	410	411	111	2
CBAR	307	1102	411	412	112	2
CBAR	308	1102	412	413	113	2
CBAR	309	1102	413	414	114	2
CBAR	310	1102	414	415	115	2
CBAR	311	1102	415	416	116	2
CBAR	312	1102	416	401	101	2
CBAR	313	1101	501	502	102	2
CBAR	314	1101	502	503	103	2
CBAR	315	1101	503	504	104	2
CBAR	316	1101	504	505	105	2
CBAR	317	1101	505	506	106	2
CBAR	318	1101	506	507	107	2
CBAR	319	1101	507	508	108	2
CBAR	320	1101	508	509	109	2
CBAR	321	1101	509	510	110	2
CBAR	322	1101	510	511	111	2
CBAR	323	1101	511	512	112	2
CBAR	324	1101	512	513	113	2
CBAR	325	1101	513	514	114	2
CBAR	326	1101	514	515	115	2
CBAR	327	1101	515	516	116	2
CBAR	328	1101	516	501	101	2
CBAR	329	1101	601	602	102	2
CBAR	330	1101	602	603	103	2
CBAR	331	1101	603	604	104	2
CBAR	332	1101	604	605	105	2
CBAR	333	1101	605	606	106	2
CBAR	334	1101	606	607	107	2
CBAR	335	1101	607	608	108	2
CBAR	336	1101	608	609	109	2
CBAR	337	1101	609	610	110	2
CBAR	338	1101	610	611	111	2
CBAR	339	1101	611	612	112	2
CBAR	340	1101	612	613	113	2
CBAR	341	1101	613	614	114	2
CBAR	342	1101	614	615	115	2
CBAR	343	1101	615	616	116	2
CBAR	344	1101	616	601	101	2
CBAR	345	1101	701	702	102	2
CBAR	346	1101	702	703	103	2
CBAR	347	1101	703	704	104	2
CBAR	348	1101	704	705	105	2
CBAR	349	1101	705	706	106	2
CBAR	350	1101	706	707	107	2
CBAR	351	1101	707	708	108	2

CBAR	352	1101	708	709	109	2
CBAR	353	1101	709	710	110	2
CBAR	354	1101	710	711	111	2
CBAR	355	1101	711	712	112	2
CBAR	356	1101	712	713	113	2
CBAR	357	1101	713	714	114	2
CBAR	358	1101	714	715	115	2
CBAR	359	1101	715	716	116	2
CBAR	360	1101	716	701	101	2
CBAR	361	1111	801	802	102	2
CBAR	362	1111	802	803	103	2
CBAR	363	1111	803	804	104	2
CBAR	364	1111	804	805	105	2
CBAR	365	1111	805	806	106	2
CBAR	366	1111	806	807	107	2
CBAR	367	1111	807	808	108	2
CBAR	368	1111	808	809	109	2
CBAR	369	1111	809	810	110	2
CBAR	370	1111	810	811	111	2
CBAR	371	1111	811	812	112	2
CBAR	372	1111	812	813	113	2
CBAR	373	1111	813	814	114	2
CBAR	374	1111	814	815	115	2
CBAR	375	1111	815	816	116	2
CBAR	376	1111	816	801	101	2
CBAR	377	1105	551	552	302	2
CBAR	378	1105	552	553	303	2
CBAR	379	1105	553	554	304	2
CBAR	380	1105	554	555	305	2
CBAR	381	1105	555	556	306	2
CBAR	382	1105	556	557	307	2
CBAR	383	1105	557	558	308	2
CBAR	384	1105	558	559	309	2
CBAR	385	1105	559	560	310	2
CBAR	386	1105	560	561	311	2
CBAR	387	1105	561	562	312	2
CBAR	388	1105	562	563	313	2
CBAR	389	1105	563	564	314	2
CBAR	390	1105	564	565	315	2
CBAR	391	1105	565	566	316	2
CBAR	392	1105	566	551	301	2
CBAR	393	2020	651	652	302	2
CBAR	394	2020	652	653	303	2
CBAR	395	2020	653	654	304	2
CBAR	396	2020	654	655	305	2
CBAR	397	2020	655	656	306	2
CBAR	398	2020	656	657	307	2
CBAR	399	2020	657	658	308	2
CBAR	400	2020	658	659	309	2
CBAR	401	2020	659	660	310	2
CBAR	402	2020	660	661	311	2
CBAR	403	2020	661	662	312	2
CBAR	404	2020	662	663	313	2
CBAR	405	2020	663	664	314	2

CBAR	406	2020	664	665	315	2
CBAR	407	2020	665	666	316	2
CBAR	408	2020	666	651	301	2
CBAR	409	1105	751	752	302	2
CBAR	410	1105	752	753	303	2
CBAR	411	1105	753	754	304	2
CBAR	412	1105	754	755	305	2
CBAR	413	1105	755	756	306	2
CBAR	414	1105	756	757	307	2
CBAR	415	1105	757	758	308	2
CBAR	416	1105	758	759	309	2
CBAR	417	1105	759	760	310	2
CBAR	418	1105	760	761	311	2
CBAR	419	1105	761	762	312	2
CBAR	420	1105	762	763	313	2
CBAR	421	1105	763	764	314	2
CBAR	422	1105	764	765	315	2
CBAR	423	1105	765	766	316	2
CBAR	424	1105	766	751	301	2
CBAR	425	1104	851	852	302	2
CBAR	426	1104	852	853	303	2
CBAR	427	1104	853	854	304	2
CBAR	428	1104	854	855	305	2
CBAR	429	1104	855	856	306	2
CBAR	430	1104	856	857	307	2
CBAR	431	1104	857	858	308	2
CBAR	432	1104	858	859	309	2
CBAR	433	1104	859	860	310	2
CBAR	434	1104	860	861	311	2
CBAR	435	1104	861	862	312	2
CBAR	436	1104	862	863	313	2
CBAR	437	1104	863	864	314	2
CBAR	438	1104	864	865	315	2
CBAR	439	1104	865	866	316	2
CBAR	440	1104	866	851	301	2
CBAR	441	1020	101	102	902	2
CBAR	442	1020	102	103	903	2
CBAR	443	1020	103	104	904	2
CBAR	444	1020	104	105	905	2
CBAR	445	1020	105	106	906	2
CBAR	446	1020	106	107	907	2
CBAR	447	1020	107	108	908	2
CBAR	448	1020	108	109	909	2
CBAR	449	1020	109	110	910	2
CBAR	450	1020	110	111	911	2
CBAR	451	1020	111	112	912	2
CBAR	452	1020	112	113	913	2
CBAR	453	1020	113	114	914	2
CBAR	454	1020	114	115	915	2
CBAR	455	1020	115	116	916	2
CBAR	456	1020	116	101	901	2

\$

\$ QUAD ELEMENTS

\$

CQUAD2	1001	9898	101	102	202	201
CQUAD2	1002	9898	201	202	302	301
CQUAD2	1003	9898	301	302	402	401
CQUAD2	1004	9898	401	402	502	501
CQUAD2	1005	9898	501	502	602	601
CQUAD2	1006	9898	601	602	702	701
CQUAD2	1007	9898	701	702	802	801
CQUAD2	1009	9898	102	103	203	202
CQUAD2	1010	9898	202	203	303	302
CQUAD2	1011	9898	302	303	403	402
CQUAD2	1012	9898	402	403	503	502
CQUAD2	1013	9898	502	503	603	602
CQUAD2	1014	9898	602	603	703	702
CQUAD2	1015	9898	702	703	803	802
CQUAD2	1017	9898	103	104	204	203
CQUAD2	1018	9898	203	204	304	303
CQUAD2	1019	9898	303	304	404	403
CQUAD2	1020	9898	403	404	504	503
CQUAD2	1021	9898	503	504	604	603
CQUAD2	1022	9898	603	604	704	703
CQUAD2	1023	9898	703	704	804	803
CQUAD2	1025	9898	104	105	205	204
CQUAD2	1026	9898	204	205	305	304
CQUAD2	1027	9898	304	305	405	404
CQUAD2	1028	9898	404	405	505	504
CQUAD2	1029	9898	504	505	605	604
CQUAD2	1030	9898	604	605	705	704
CQUAD2	1031	9898	704	705	805	804
CQUAD2	1033	9898	105	106	206	205
CQUAD2	1034	9898	205	206	306	305
CQUAD2	1035	9898	305	306	406	405
CQUAD2	1036	9898	405	406	506	505
CQUAD2	1037	9898	505	506	606	605
CQUAD2	1038	9898	605	606	706	705
CQUAD2	1039	9898	705	706	806	805
CQUAD2	1041	9898	106	107	207	206
CQUAD2	1042	9898	206	207	307	306
CQUAD2	1043	9898	306	307	407	406
CQUAD2	1044	9898	406	407	507	506
CQUAD2	1045	9898	506	507	607	606
CQUAD2	1046	9898	606	607	707	706
CQUAD2	1047	9898	706	707	807	806
CQUAD2	1049	9898	107	108	208	207
CQUAD2	1050	9898	207	208	308	307
CQUAD2	1051	9898	307	308	408	407
CQUAD2	1052	9898	407	408	508	507
CQUAD2	1053	9898	507	508	608	607
CQUAD2	1054	9898	607	608	708	707
CQUAD2	1055	9898	707	708	808	807
CQUAD2	1057	9898	108	109	209	208
CQUAD2	1058	9898	208	209	309	308
CQUAD2	1059	9898	308	309	409	408
CQUAD2	1060	9898	408	409	509	508
CQUAD2	1061	9898	508	509	609	608

CQUAD2	1062	9898	608	609	709	708
CQUAD2	1063	9898	708	709	809	808
CQUAD2	1065	9898	109	110	210	209
CQUAD2	1066	9898	209	210	310	309
CQUAD2	1067	9898	309	310	410	409
CQUAD2	1068	9898	409	410	510	509
CQUAD2	1069	9898	509	510	610	609
CQUAD2	1070	9898	609	610	710	709
CQUAD2	1071	9898	709	710	810	809
CQUAD2	1073	9898	110	111	211	210
CQUAD2	1074	9898	210	211	311	310
CQUAD2	1075	9898	310	311	411	410
CQUAD2	1076	9898	410	411	511	510
CQUAD2	1077	9898	510	511	611	610
CQUAD2	1078	9898	610	611	711	710
CQUAD2	1079	9898	710	711	811	810
CQUAD2	1081	9898	111	112	212	211
CQUAD2	1082	9898	211	212	312	311
CQUAD2	1083	9898	311	312	412	411
CQUAD2	1084	9898	411	412	512	511
CQUAD2	1085	9898	511	512	612	611
CQUAD2	1086	9898	611	612	712	711
CQUAD2	1087	9898	711	712	812	811
CQUAD2	1089	9898	112	113	213	212
CQUAD2	1090	9898	212	213	313	312
CQUAD2	1091	9898	312	313	413	412
CQUAD2	1092	9898	412	413	513	512
CQUAD2	1093	9898	512	513	613	612
CQUAD2	1094	9898	612	613	713	712
CQUAD2	1095	9898	712	713	813	812
CQUAD2	1097	9898	113	114	214	213
CQUAD2	1098	9898	213	214	314	313
CQUAD2	1099	9898	313	314	414	413
CQUAD2	1100	9898	413	414	514	513
CQUAD2	1101	9898	513	514	614	613
CQUAD2	1102	9898	613	614	714	713
CQUAD2	1103	9898	713	714	814	813
CQUAD2	1105	9898	114	115	215	214
CQUAD2	1106	9898	214	215	315	314
CQUAD2	1107	9898	314	315	415	414
CQUAD2	1108	9898	414	415	515	514
CQUAD2	1109	9898	514	515	615	614
CQUAD2	1110	9898	614	615	715	714
CQUAD2	1111	9898	714	715	815	814
CQUAD2	1113	9898	115	116	216	215
CQUAD2	1114	9898	215	216	316	315
CQUAD2	1115	9898	315	316	416	415
CQUAD2	1116	9898	415	416	516	515
CQUAD2	1117	9898	515	516	616	615
CQUAD2	1118	9898	615	616	716	715
CQUAD2	1119	9898	715	716	816	815
CQUAD2	1121	9898	116	101	201	216
CQUAD2	1122	9898	216	201	301	316
CQUAD2	1123	9898	316	301	401	416

CQUAD2	1124	9898	416	401	501	516
CQUAD2	1125	9898	516	501	601	616
CQUAD2	1126	9898	616	601	701	716
CQUAD2	1127	9898	716	701	801	816

\$

\$ CONE SECTION QUADS

\$

CQUAD2	1129	1100	301	302	552	551
CQUAD2	1130	1100	551	552	652	651
CQUAD2	1131	1100	651	652	752	751
CQUAD2	1132	1100	751	752	852	851
CQUAD2	1133	1100	302	303	553	552
CQUAD2	1134	1100	552	553	653	652
CQUAD2	1135	1100	652	653	753	752
CQUAD2	1136	1100	752	753	853	852
CQUAD2	1137	1100	303	304	554	553
CQUAD2	1138	1100	553	554	654	653
CQUAD2	1139	1100	653	654	754	753
CQUAD2	1140	1100	753	754	854	853
CQUAD2	1141	1100	304	305	555	554
CQUAD2	1142	1100	554	555	655	654
CQUAD2	1143	1100	654	655	755	754
CQUAD2	1144	1100	754	755	855	854
CQUAD2	1145	1100	305	306	556	555
CQUAD2	1146	1100	555	556	656	655
CQUAD2	1147	1100	655	656	756	755
CQUAD2	1148	1100	755	756	856	855
CQUAD2	1149	1100	306	307	557	556
CQUAD2	1150	1100	556	557	657	656
CQUAD2	1151	1100	656	657	757	756
CQUAD2	1152	1100	756	757	857	856
CQUAD2	1153	1100	307	308	558	557
CQUAD2	1154	1100	557	558	658	657
CQUAD2	1155	1100	657	658	758	757
CQUAD2	1156	1100	757	758	858	857
CQUAD2	1157	1100	308	309	559	558
CQUAD2	1158	1100	558	559	659	658
CQUAD2	1159	1100	658	659	759	758
CQUAD2	1160	1100	758	759	859	858
CQUAD2	1161	1100	309	310	560	559
CQUAD2	1162	1100	559	560	660	659
CQUAD2	1163	1100	659	660	760	759
CQUAD2	1164	1100	759	760	860	859
CQUAD2	1165	1100	310	311	561	560
CQUAD2	1166	1100	560	561	661	660
CQUAD2	1167	1100	660	661	761	760
CQUAD2	1168	1100	760	761	861	860
CQUAD2	1169	1100	311	312	562	561
CQUAD2	1170	1100	561	562	662	661
CQUAD2	1171	1100	661	662	762	761
CQUAD2	1172	1100	761	762	862	861
CQUAD2	1173	1100	312	313	563	562
CQUAD2	1174	1100	562	563	663	662
CQUAD2	1175	1100	662	663	763	762

CQUAD2	1176	1100	762	763	863	862
CQUAD2	1177	1100	313	314	564	563
CQUAD2	1178	1100	563	564	664	663
CQUAD2	1179	1100	663	664	764	763
CQUAD2	1180	1100	763	764	864	863
CQUAD2	1181	1100	314	315	565	564
CQUAD2	1182	1100	564	565	665	664
CQUAD2	1183	1100	664	665	765	764
CQUAD2	1184	1100	764	765	865	864
CQUAD2	1185	1100	315	316	566	565
CQUAD2	1186	1100	565	566	666	665
CQUAD2	1187	1100	665	666	766	765
CQUAD2	1188	1100	765	766	866	865

\$
 \$ LH2 AND LO2 LUMPED MASSES FOR THE X-DIR (AXIAL SLOSH)
 \$

CONM1	3050	80	1046002.
CONM1	3051	81	210158.

\$
 \$ NOSE CONE, SHROUD, PAYLOAD MASSES
 \$

CONM2	3999	999	50000.		+C999
+C999	1.732+09		2.207+09	2.207+09	
CONM2	3001	1	20.000		+C01
+C01	6.727+05				
CONM2	3002	2	300.00		+C02
+C02	4.256+06				
CONM2	3003	3	548.00		+C03
+C03	5.602+06				
CONM2	3004	4	1076.0		+C04
+C04	1.207+07				
CONM2	3005	5	720.00		+C05
+C05	1.045+08				
CONM2	3006	6	720.00		+C06
+C06	6.673+07				
CONM2	3007	7	720.00		+C07
+C07	3.822+07				
CONM2	3008	8	720.00		+C08
+C08	1.891+07				
CONM2	3009	9	720.00		+C09
+C09	8.828+06				
CONM2	3010	10	720.00		+C10
+C10	7.958+06				
CONM2	3011	11	720.00		+C11
+C11	1.630+07				
CONM2	3012	12	720.00		+C12
+C12	3.387+07				
CONM2	3013	13	720.00		+C13
+C13	6.064+07				
CONM2	3014	14	720.00		+C14
+C14	9.664+07				
CONM2	3015	15	5078.00		+C15
+C15	2.203+08				
CONM2	3016	16	1128.0		+C16

+C16	6.399+07				
CONM2	3017	17	1128.0		+C17
+C17	4.411+07				

\$

\$ LO2 TANK MASSES IN Y,Z DIRECTIONS WITH PARTIAL X-DIR

\$

CONM1	3018	18	58684.9	208113.8	A18
+18	208113.8			2.058+08	
CONM1	3019	19	57556.9	206985.8	A19
+19	206985.8			1.591+08	
CONM1	3020	20	57556.9	206985.8	A20
+20	206985.8			8.398+07	
CONM1	3021	21	57556.9	206985.8	A21
+21	206985.8			4.874+07	
CONM1	3022	22	57556.9	206985.8	A22
+22	206985.8			4.923+07	
CONM1	3023	23	60373.9	209802.8	A23
+23	209802.8			2.083+08	
CONM1	3024	24	60373.9	209802.8	A24
+24	209802.8			2.020+08	

\$

\$ PART OF THE MASS OF THE INNER TANK

\$

CONM2	3025	25	3400.3		
-------	------	----	--------	--	--

\$

\$ LH2 TANK MASSES IN Y,Z DIRECTIONS WITH PARTIAL X-DIR

\$

CONM1	3026	26	9491.1	25657.1	A26
+26	25657.1			1.192+09	
CONM1	3027	27	9491.1	25657.1	A27
+27	25657.1			8.243+08	
CONM1	3028	28	6674.1	22840.1	A28
+28	22840.1			4.847+08	
CONM1	3029	29	6674.1	22840.1	A29
+29	22840.1			2.718+08	
CONM1	3030	30	6674.1	22840.1	A30
+30	22840.1			1.354+08	
CONM1	3031	31	6674.1	22840.1	A31
+31	22840.1			7.583+07	
CONM1	3032	32	6674.1	22840.1	A32
+32	22840.1			9.289+07	
CONM1	3033	33	6674.1	22840.1	A33
+33	22840.1			1.866+08	
CONM1	3034	34	6674.1	22840.1	A34
+34	22840.1			3.571+08	
CONM1	3035	35	6674.1	22840.1	A35
+35	22840.1			6.042+08	
CONM1	3036	36	7335.5	23501.4	A36
+36	23501.4			7.064+08	
CONM1	3037	37	7335.5	23501.4	A37
+37	23501.4			7.924+08	
CONM1	3038	38	7335.5	23501.4	A38
+38	23501.4			1.142+09	

\$

CONM2	3042	803		8004.					+C42
+C42	4.059+07		1.953+07			1.953+07			
CONM2	3043	807		8004.					+C43
+C43	4.059+07		1.953+07			1.953+07			
CONM2	3044	811		8004.					+C44
+C44	4.059+07		1.953+07			1.953+07			
CONM2	3045	815		8004.					+C45
+C45	4.059+07		1.953+07			1.953+07			
CONM2	3046	851		8004.					+C46
+C46	4.059+07		1.953+07			1.953+07			
CONM2	3047	859		8004.					+C47
+C47	4.059+07		1.953+07			1.953+07			
EIGR	40	FEER	1.00			15		1.-4	+EIG1
+EIG1	MAX								
EIGR	41	INV	0.0	10.	60	15		1.-5	+EIG2
+EIG2	MAX								
EIGR	42	GIV				15		1.-4	+EIGR
+EIGR	MAX								
GRID	1		1306.06	0.0	0.0				
GRID	2		1395.10	0.0	0.0				
GRID	3		1444.87	0.0	0.0				
GRID	4		1494.64	0.0	0.0				
GRID	5		1544.40	0.0	0.0				
GRID	6		1624.4	0.0	0.0				
GRID	7		1704.4	0.0	0.0				
GRID	8		1784.4	0.0	0.0				
GRID	9		1864.4	0.0	0.0				
GRID	10		1944.4	0.0	0.0				
GRID	11		2024.4	0.0	0.0				
GRID	12		2104.4	0.0	0.0				
GRID	13		2184.4	0.0	0.0				
GRID	14		2264.40	0.0	0.0				
GRID	15		2284.80	0.0	0.0				
GRID	16		2347.8	0.0	0.0				
GRID	17		2410.8	0.0	0.0				
GRID	18		2459.1750.0		0.0				
GRID	19		2471.15	0.0	0.0				
GRID	20		2569.8	0.0	0.0				
GRID	21		2664.1330.0		0.0				
GRID	22		2758.4670.0		0.0				
GRID	23		2852.8	0.0	0.0				
GRID	24		2963.4250.0		0.0				
GRID	25		2985.6750.0		0.0				
GRID	26		3012.5250.0		0.0				
GRID	27		3123.15	0.0	0.0				
GRID	28		3240.0060.0		0.0				
GRID	29		3356.8630.0		0.0				
GRID	30		3473.7190.0		0.0				
GRID	31		3590.5750.0		0.0				
GRID	32		3707.4310.0		0.0				
GRID	33		3824.2880.0		0.0				
GRID	34		3941.1440.0		0.0				
GRID	35		4058.0	0.0	0.0				
GRID	36		4090.3250.0		0.0				

GRID	37	4122.65	0.0	0.0	
\$ THESE CARDS WHICH FOLLOW ARE THE OLD STICK METHOD					
\$					
GRID	38	4233.2750.0		0.0	
GRID	80	2963.4250.0		0.0	23456
GRID	81	4233.2750.0		0.0	23456
GRID	99	4687.06	1.0	0.0	123456
GRID	999	1997.58	0.0	0.0	
\$					
\$\$THE FOLLOWING CARDS DESCRIBE THE NEW THRUST STRUCTURE					
\$					
\$					
GRID	901	4000.0	0.0	165.463	123456
GRID	902	4000.0	63.32	152.868	123456
GRID	903	4000.0	117.0	117.0	123456
GRID	904	4000.0	152.868	63.32	123456
GRID	905	4000.0	165.463	0.0	123456
GRID	906	4000.0	152.868	-63.32	123456
GRID	907	4000.0	117.0	-117.0	123456
GRID	908	4000.0	63.32	-152.868	123456
GRID	909	4000.0	0.0	-165.463	123456
GRID	910	4000.0	-63.32	-152.868	123456
GRID	911	4000.0	-117.0	-117.0	123456
GRID	912	4000.0	-152.868	-63.32	123456
GRID	913	4000.0	-165.463	0.0	123456
GRID	914	4000.0	-152.868	63.32	123456
GRID	915	4000.0	-117.0	117.0	123456
GRID	916	4000.0	-63.32	152.868	123456
GRID	101	4122.65	0.0	165.463	
GRID	102	4122.65	63.32	152.868	
GRID	103	4122.65	117.0	117.0	
GRID	104	4122.65	152.868	63.32	
GRID	105	4122.65	165.463	0.0	
GRID	106	4122.65	152.868	-63.32	
GRID	107	4122.65	117.0	-117.0	
GRID	108	4122.65	63.32	-152.868	
GRID	109	4122.65	0.0	-165.463	
GRID	110	4122.65	-63.32	-152.868	
GRID	111	4122.65	-117.0	-117.0	
GRID	112	4122.65	-152.868	-63.32	
GRID	113	4122.65	-165.463	0.0	
GRID	114	4122.65	-152.868	63.32	
GRID	115	4122.65	-117.0	117.0	
GRID	116	4122.65	-63.32	152.868	
GRID	201	4166.5750.0		165.463	
GRID	202	4166.57563.32		152.868	
GRID	203	4166.575117.0		117.0	
GRID	204	4166.575152.868		63.32	
GRID	205	4166.575165.463		0.0	
GRID	206	4166.575152.868		-63.32	
GRID	207	4166.575117.0		-117.0	
GRID	208	4166.57563.32		-152.868	
GRID	209	4166.5750.0		-165.463	
GRID	210	4166.575-63.32		-152.868	

GRID	211	4166.575-117.0	-117.0
GRID	212	4166.575-152.868	-63.32
GRID	213	4166.575-165.463	0.0
GRID	214	4166.575-152.868	63.32
GRID	215	4166.575-117.0	117.0
GRID	216	4166.575-63.32	152.868
GRID	301	4210.3250.0	165.463
GRID	302	4210.32563.32	152.868
GRID	303	4210.325117.0	117.0
GRID	304	4210.325152.868	63.32
GRID	305	4210.325165.463	0.0
GRID	306	4210.325152.868	-63.32
GRID	307	4210.325117.0	-117.0
GRID	308	4210.32563.32	-152.868
GRID	309	4210.3250.0	-165.463
GRID	310	4210.325-63.32	-152.868
GRID	311	4210.325-117.0	-117.0
GRID	312	4210.325-152.868	-63.32
GRID	313	4210.325-165.463	0.0
GRID	314	4210.325-152.868	63.32
GRID	315	4210.325-117.0	117.0
GRID	316	4210.325-63.32	152.868
GRID	401	4227.37 0.0	165.463
GRID	402	4227.37 63.32	152.868
GRID	403	4227.37 117.0	117.0
GRID	404	4227.37 152.868	63.32
GRID	405	4227.37 165.463	0.0
GRID	406	4227.37 152.868	-63.32
GRID	407	4227.37 117.0	-117.0
GRID	408	4227.37 63.32	-152.868
GRID	409	4227.37 0.0	-165.463
GRID	410	4227.37 -63.32	-152.868
GRID	411	4227.37 -117.0	-117.0
GRID	412	4227.37 -152.868	-63.32
GRID	413	4227.37 -165.463	0.0
GRID	414	4227.37 -152.868	63.32
GRID	415	4227.37 -117.0	117.0
GRID	416	4227.37 -63.32	152.868
GRID	501	4254.0750.0	165.463
GRID	502	4254.07563.32	152.868
GRID	503	4254.075117.0	117.0
GRID	504	4254.075152.868	63.32
GRID	505	4254.075165.463	0.0
GRID	506	4254.075152.868	-63.32
GRID	507	4254.075117.0	-117.0
GRID	508	4254.07563.32	-152.868
GRID	509	4254.0750.0	-165.463
GRID	510	4254.075-63.32	-152.868
GRID	511	4254.075-117.0	-117.0
GRID	512	4254.075-152.868	-63.32
GRID	513	4254.075-165.463	0.0
GRID	514	4254.075-152.868	63.32
GRID	515	4254.075-117.0	117.0
GRID	516	4254.075-63.32	152.868

GRID	601	4297.8250.0	165.463
GRID	602	4297.82563.32	152.868
GRID	603	4297.825117.0	117.0
GRID	604	4297.825152.868	63.32
GRID	605	4297.825165.463	0.0
GRID	606	4297.825152.868	-63.32
GRID	607	4297.825117.0	-117.0
GRID	608	4297.82563.32	-152.868
GRID	609	4297.8250.0	-165.463
GRID	610	4297.825-63.32	-152.868
GRID	611	4297.825-117.0	-117.0
GRID	612	4297.825-152.868	-63.32
GRID	613	4297.825-165.463	0.0
GRID	614	4297.825-152.868	63.32
GRID	615	4297.825-117.0	117.0
GRID	616	4297.825-63.32	152.868
GRID	701	4341.5750.0	165.463
GRID	702	4341.57563.32	152.868
GRID	703	4341.575117.0	117.0
GRID	704	4341.575152.868	63.32
GRID	705	4341.575165.463	0.0
GRID	706	4341.575152.868	-63.32
GRID	707	4341.575117.0	-117.0
GRID	708	4341.57563.32	-152.868
GRID	709	4341.5750.0	-165.463
GRID	710	4341.575-63.32	-152.868
GRID	711	4341.575-117.0	-117.0
GRID	712	4341.575-152.868	-63.32
GRID	713	4341.575-165.463	0.0
GRID	714	4341.575-152.868	63.32
GRID	715	4341.575-117.0	117.0
GRID	716	4341.575-63.32	152.868
GRID	801	4385.5 0.0	165.463
GRID	802	4385.5 63.32	152.868
GRID	803	4385.5 117.0	117.0
GRID	804	4385.5 152.868	63.32
GRID	805	4385.5 165.463	0.0
GRID	806	4385.5 152.868	-63.32
GRID	807	4385.5 117.0	-117.0
GRID	808	4385.5 63.32	-152.868
GRID	809	4385.5 0.0	-165.463
GRID	810	4385.5 -63.32	-152.868
GRID	811	4385.5 -117.0	-117.0
GRID	812	4385.5 -152.868	-63.32
GRID	813	4385.5 -165.463	0.0
GRID	814	4385.5 -152.868	63.32
GRID	815	4385.5 -117.0	117.0
GRID	816	4385.5 -63.32	152.868
GRID	551	4254.0750.0	141.371
GRID	552	4254.07554.10	130.61
GRID	553	4254.07599.965	99.965
GRID	554	4254.075130.61	54.10
GRID	555	4254.075141.371	0.0
GRID	556	4254.075130.61	-54.10

GRID	557	4254.07599.965	-99.965
GRID	558	4254.07554.10	-130.61
GRID	559	4254.0750.0	-141.371
GRID	560	4254.075-54.10	-130.61
GRID	561	4254.075-99.965	-99.965
GRID	562	4254.075-130.61	-54.10
GRID	563	4254.075-141.3710.0	
GRID	564	4254.075-130.61	54.10
GRID	565	4254.075-99.965	99.965
GRID	566	4254.075-54.10	130.61
GRID	651	4297.8250.0	117.280
GRID	652	4297.82544.881	108.352
GRID	653	4297.82582.929	82.929
GRID	654	4297.825108.352	44.881
GRID	655	4297.825117.280	0.0
GRID	656	4297.825108.352	-44.881
GRID	657	4297.82582.929	-82.929
GRID	658	4297.82544.881	-108.352
GRID	659	4297.8250.0	-117.280
GRID	660	4297.825-44.881	-108.352
GRID	661	4297.825-82.929	-82.929
GRID	662	4297.825-108.352	-44.881
GRID	663	4297.825-117.2800.0	
GRID	664	4297.825-108.352	44.881
GRID	665	4297.825-82.929	82.929
GRID	666	4297.825-44.881	108.352
GRID	751	4341.5750.0	93.188
GRID	752	4341.57535.662	86.095
GRID	753	4341.57565.894	65.894
GRID	754	4341.57586.095	35.662
GRID	755	4341.57593.188	0.0
GRID	756	4341.57586.095	-35.662
GRID	757	4341.57565.894	-65.894
GRID	758	4341.57535.662	-86.095
GRID	759	4341.5750.0	-93.188
GRID	760	4341.575-35.662	-86.095
GRID	761	4341.575-65.894	-65.894
GRID	762	4341.575-86.095	-35.662
GRID	763	4341.575-93.188	0.0
GRID	764	4341.575-86.095	35.662
GRID	765	4341.575-65.894	65.894
GRID	766	4341.575-35.662	86.095
GRID	851	4385.5 0.0	69.000
GRID	852	4385.5 26.405	63.748
GRID	853	4385.5 48.791	48.791
GRID	854	4385.5 63.748	26.405
GRID	855	4385.5 69.000	0.0
GRID	856	4385.5 63.748	-26.405
GRID	857	4385.5 48.791	-48.791
GRID	858	4385.5 26.405	-63.748
GRID	859	4385.5 0.0	-69.000
GRID	860	4385.5 -26.405	-63.748
GRID	861	4385.5 -48.791	-48.791
GRID	862	4385.5 -63.748	-26.405

GRID	863	4385.5	-69.000	0.0
GRID	864	4385.5	-63.748	26.405
GRID	865	4385.5	-48.791	48.791
GRID	866	4385.5	-26.405	63.748

\$

\$ THE FOLLOWING GRIDS ARE FOR BAR ORIENTATION

\$

GRID	881	5000.0	0.0	200.0	123456		
GRID	883	5000.0	200.0	200.0	123456		
GRID	885	5000.0	200.0	0.0	123456		
GRID	887	5000.0	200.0	-200.0	123456		
GRID	889	5000.0	0.0	-200.0	123456		
GRID	891	5000.0	-200.0	-200.0	123456		
GRID	893	5000.0	-200.0	0.0	123456		
GRID	895	5000.0	-200.0	200.0	123456		
\$MAT1	2001	1.050+7	4.000+6	0.31250	5.000		
MAT1	2001	1.050+7	4.000+6	0.31250			
MAT1	2002	1.050+7	4.000+6	0.31250	0.208		
PARAM	GRDPNT	0					
PARAM	WTMASS	2.591E-3					
PBAR	1001	2001	149.517	4.18E+6	2.79E+6	4.99E+6	0.0
PBAR	1002	2001	254.65	4.18E+6	2.79E+6	7.08E+6	0.0
PBAR	1003	2001	237.18	3.79E+6	2.69E+6	5.91E+6	0.0
PBAR	1004	2001	216.425	3.33E+6	2.60E+6	6.42E+6	0.0
PBAR	1005	2001	263.83	4.51E+6	2.72E+6	4.99E+6	0.0
PBAR	1006	2001	263.79	4.66E+6	2.41E+6	4.99E+6	0.0
PBAR	1007	2001	363.79	7.12E+6	2.84E+6	4.99E+6	0.0
PBAR	1008	2001	273.83	4.84E+6	2.66E+6	4.99E+6	0.0
PBAR	1009	2001	209.16	2.99E+6	2.63E+6	4.99E+6	0.0
PBAR	1010	2001	179.04	2.53E+6	2.37E+6	4.99E+6	0.0
PBAR	1011	2001	147.87	2.03E+6	2.03E+6	2.65E+6	0.0
PBAR	1012	2001	145.06	1.99E+6	1.99E+6	2.54E+6	0.0
PBAR	1013	2001	196.984	2.68E+6	2.71E+6	2.43E+6	0.0
PBAR	1014	2001	225.198	3.07E+6	3.096E+6	2.34E+6	0.0
PBAR	1015	2001	213.168	2.97E+6	2.87E+6	2.31E+6	0.0
PBAR	1016	2001	50.0	2.97E+3	2.87E+3	2.31E+3	0.0
PBAR	1020	2001	200.	9.99E+9	9.99E+9	9.99E+9	0.0
PBAR	1111	2002	55.30	920.00	26128.0	27048.0	
PBAR	1101	2002	37.60	560.24	8360.00	8920.24	
PBAR	1102	2002	7.56	17.448	180.248	197.696	
PBAR	1103	2002	17.358	169.04	1596.0	1765.04	
PBAR	1104	2002	20.000	170.4	2712.0	2882.4	
PBAR	1105	2002	10.0	53.6	451.2	504.8	
PBAR	2020	2002	2.0	4.0	4.0	8.000	0.0
PBAR	2021	2002	7.984	1.5104	258.79	260.3	
PBAR	2022	2002	13.28	22.784	482.836	505.62	
PBAR	2023	2002	19.85	114.122	761.083	875.205	
PBAR	2024	2002	26.43	312.564	1039.9	1352.464	
PBAR	2025	2002	6.971	0.16597	219.94	220.106	
PBAR	2026	2002	9.879	4.5158	352.49	357.006	
PBAR	2027	2002	13.49	29.338	517.116	546.454	
PBAR	2028	2002	17.11	92.4519	682.078	774.530	
PBAR	2031	2002	6.564	29.3878	239.174	268.562	
PBAR	2032	2002	9.0399	25.5846	314.236	339.821	

PBAR	2033	2002	12.334	37.5201	464.362	501.882
PBAR	2034	2002	15.634	85.3905	614.791	700.182
PQUAD2	1100	2002	0.250	0.0		
PQUAD2	9898	2002	0.195	0.0		
SPC1	100	23456	80	81		
\$SPC1	100	123	801	805	809	813

\$
 \$ AXIS DIRECTION INDICATORS
 \$
 \$

GRID	50000		0.0	0.0	0.0	123456
GRID	50001		10.0	0.0	0.0	123456
GRID	50002		0.0	10.0	0.0	123456
GRID	50003		0.0	0.0	10.0	123456

ENDDATA

NLS1 FREQUENCIES (HZ)

FIXED FREQUENCIES (HZ)

MODE	FREQUENCY	MODE	FREQUENCY	MODE	FREQUENCY
1	0.19	28	6.47	54	14.57
2	0.45	29	6.47	55	14.70
3	0.80	30	6.69	56	14.77
4	0.82	31	6.80	57	14.82
5	1.44	32	7.12	58	14.82
6	1.48	33	7.96	59	15.14
7	2.17	34	8.03	60	15.14
8	2.31	35	8.04	61	15.21
9	2.56	36	8.09	62	15.24
10	2.56	37	8.48	63	15.65
11	2.56	38	8.70	64	15.65
12	2.56	39	8.92	65	15.77
13	2.59	40	9.80	66	15.77
14	2.91	41	9.83	67	16.25
15	3.30	42	10.00	68	16.41
16	3.30	43	10.09	69	17.80
17	3.90	44	10.70	70	17.80
18	4.00	45	10.78	71	17.82
19	4.02	46	10.92	72	17.83
20	4.08	47	11.01	73	18.17
21	4.27	48	11.07	74	18.17
22	4.36	49	11.70	75	18.18
23	5.83	50	11.72	76	18.34
24	6.04	51	11.95	77	19.77
25	6.05	52	14.24	78	19.77
26	6.25	53	14.57	79	20.17
27	6.46				

FREE-FREE FREQUENCIES (HZ)

MODE	FREQUENCY	MODE	FREQUENCY	MODE	FREQUENCY
1	0.00	29	4.46	58	14.28
2	0.00	30	4.70	59	14.28
3	0.00	31	6.23	60	14.30
4	0.00	32	6.45	61	14.80
5	0.00	33	6.46	62	14.80
6	0.00	34	6.69	63	14.82
7	0.61	35	6.76	64	14.84
8	0.64	36	6.80	65	15.26
9	1.35	37	7.09	66	15.26
10	1.49	38	7.55	67	15.26
11	1.83	39	7.96	68	15.27
12	2.42	40	8.00	69	15.44
13	2.50	41	8.03	70	15.44
14	2.51	42	8.06	71	17.55
15	2.56	43	8.48	72	17.80
16	2.57	44	9.82	73	17.81
17	2.57	46	10.34	74	17.81
18	2.60	47	10.71	75	17.82
19	2.92	48	10.73	76	18.06
20	3.17	49	10.81	77	18.31
21	3.24	50	10.87	78	18.50
22	3.32	51	10.94	79	18.85
23	3.35	52	11.69	80	18.85
24	3.35	53	11.70	81	19.77
25	3.99	54	12.70	82	19.77
26	4.04	55	13.31	83	19.85
27	4.30	56	13.81	84	20.13
28	4.44	57	13.81		

NLS2 FREQUENCIES (HZ)

FIXED FREQUENCIES

MODE	FREQUENCY
1	0.31
2	0.31
3	2.48
4	2.56
5	2.72
6	3.46
7	7.05
8	7.35
9	7.58
10	8.96
11	10.45
12	11.44
13	11.80
14	12.86
15	13.13
16	13.38
17	15.31
18	16.08
19	16.65
20	17.15
21	18.19

FREE-FREE FREQUENCIES

MODE	FREQUENCY
1	0.00
2	0.00
3	0.00
4	0.00
5	0.00
6	0.00
7	2.53
8	2.68
9	4.95
10	5.11
11	7.15
12	7.84
13	8.10
14	11.37
15	11.80
16	12.57
17	13.01
18	13.41
19	15.02
20	15.49
21	15.63
22	16.74
23	19.87

FORCING FUNCTION DATA

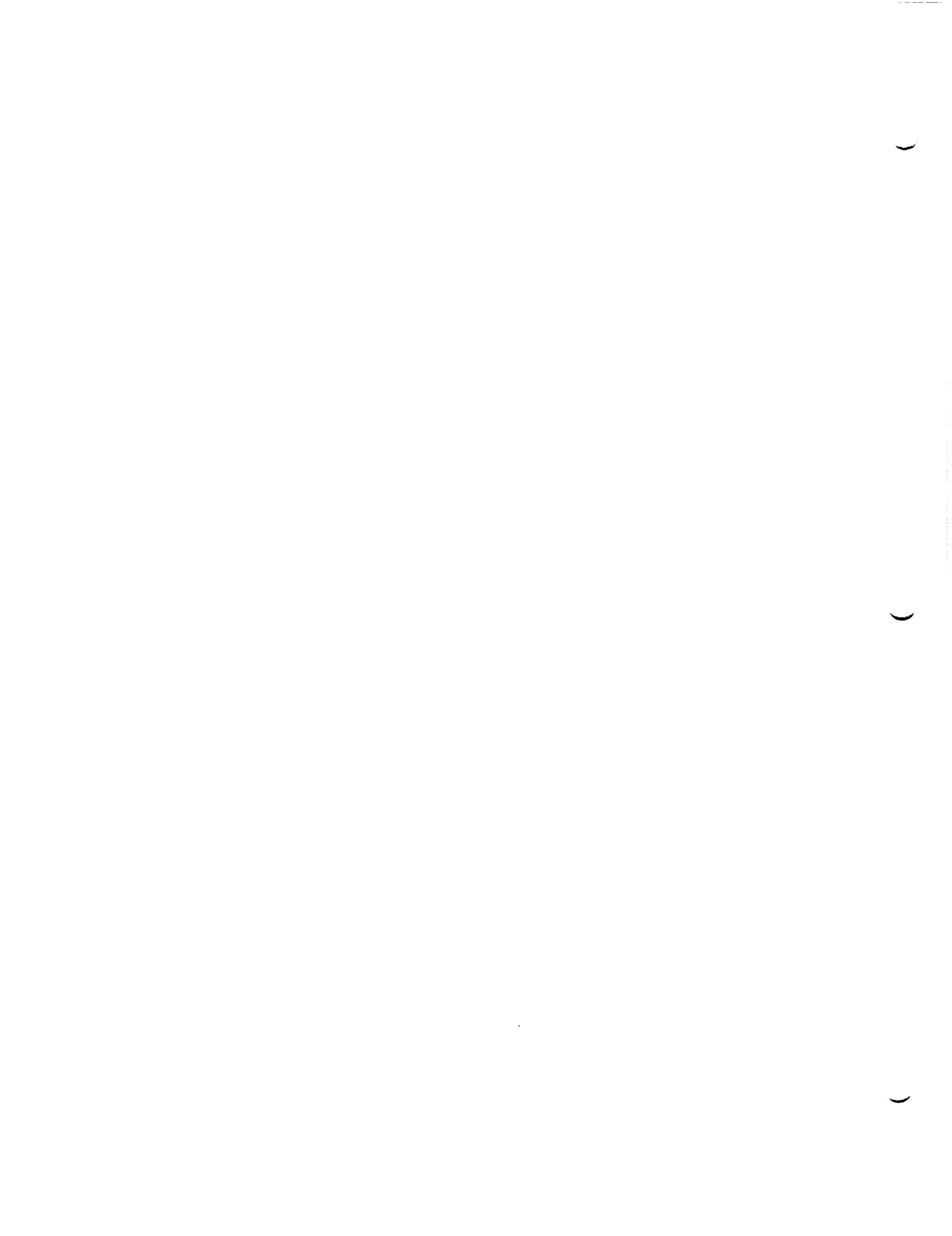

ASRB THRUST AND PRESSURE CASE DESCRIPTION

CASE	FILENAME	DESCRIPTION
A1	NNMNMOL NNMNMOR	Nominal pair of motors
A2	AV2L AV2R	Nominal pair of motors with plus 2 sigma ignition timing
A3	NMXNMOL NMXNMOR	Nominal pair of motors with plus 2 sigma thrust rise rate
A4	NNMMXOL NNMMXOR	Nominal pair of motors with plus 2 sigma steady-state thrust level
A5	LNMMNMOL LNMMNMOR	Nominal pair of motors with plus 2 sigma ignition interval
A6	NNMNM2L NNMNM2R	Nominal pair of motors with plus 2 sigma ignition thrust differential
A11	AVM2L AVM2R	Nominal pair of motors with minus 2 sigma ignition timing
A12	NMNNMOL NMNNMOR	Nominal pair of motors with minus 2 sigma thrust rise rate
A13	NNMMNOL NNMMNOR	Nominal pair of motors with minus 2 sigma steady-state thrust level
A14	ENMMNMOL ENMMNMOR	Nominal pair of motors with minus 2 sigma ignition interval
A15	NNMNM2L NNMNM2R	Nominal pair of motors with minus 2 sigma ignition thrust differential
A20	EMXMX2L EMXMX2R	Pair of motors with plus 2 sigma for all motor parameters
A21	LMNMN2L LMNMN2R	Pair of motors with minus 2 sigma for all motor parameters

NLS1 BUILDUP/SHUTDOWN LOAD CASES FOR CYCLE I DESIGN

CASE NAME --->	BUSD09	BUSD10	BUSD11	BUSD12	BUSD13	BUSD14	BUSD15	BUSD16	BUSD17
STME 1 IGNITION STAGGER (SECONDS)	0.0	0.0	0.0	0.0	0.0	0.0	0.0	0.0	0.0
STME 2 IGNITION STAGGER (SECONDS)	0.0	0.0	0.0	0.0	0.0	0.0	0.0	0.0	0.0
STME 3 IGNITION STAGGER (SECONDS)	0.0	0.0	0.0	0.0	0.0	0.0	0.0	0.0	0.0
STME 4 IGNITION STAGGER (SECONDS)	0.0	0.0	0.0	0.0	0.0	0.0	0.0	0.0	0.0
STME THRUST BUILD-UP DESCRIPTION	MAX	MAX	MAX	MAX*	MAX**	MAX*	MAX*	MAX*	MAX*
STME 1 IGNITION TIMING	0.0	0.0	0.0	0.0	0.0	0.0	0.0	0.0	0.0
STME 2 IGNITION TIMING	0.0	0.0	0.0	0.0	0.0	0.0	0.0	0.0	0.0
STME 3 IGNITION TIMING	0.0	0.0	0.0	0.0	0.0	0.0	0.0	0.0	0.0
STME 4 IGNITION TIMING	0.0	0.0	0.0	0.0	0.0	0.0	0.0	0.0	0.0
STME THRUST MISALIGNMENT	0.0°	+0.4° ABOUT Z	+0.4° ABOUT Y	0.0°	0.0°	0.0°	0.0°	+0.4° ABOUT Y	0.0°
STME IGNITION SIDELOADS MAGNITUDES	N/A	N/A	N/A	N/A	N/A	N/A	N/A	N/A	N/A
WIND DIRECTION (NO DISPERSIONS)	Z-DIR	Y-DIR	Z-DIR	NONE	NONE	NONE	Z-DIR	Z-DIR	NONE
SRB IGNITION TIMING	N/A	N/A	N/A	N/A	N/A	N/A	N/A	N/A	N/A
SRB THRUST RISE RATE	N/A	N/A	N/A	N/A	N/A	N/A	N/A	N/A	N/A
SRB THRUST LEVEL	N/A	N/A	N/A	N/A	N/A	N/A	N/A	N/A	N/A
SRB IGNITION INTERVAL	N/A	N/A	N/A	N/A	N/A	N/A	N/A	N/A	N/A
SRB THRUST MISMATCH	N/A	N/A	N/A	N/A	N/A	N/A	N/A	N/A	N/A
SRB THRUST MISALIGNMENT	N/A	N/A	N/A	N/A	N/A	N/A	N/A	N/A	N/A
SRB THRUST OFFSET	N/A	N/A	N/A	N/A	N/A	N/A	N/A	N/A	N/A
SRB IGNITION OVERPRESSURE	N/A	N/A	N/A	N/A	N/A	N/A	N/A	N/A	N/A
SRB IOP TIMING TOLERANCE (SECONDS)	N/A	N/A	N/A	N/A	N/A	N/A	N/A	N/A	N/A
SRB GROWTH	N/A	N/A	N/A	N/A	N/A	N/A	N/A	N/A	N/A
HOLDOWN BOLT TIMING	NONE	NONE	NONE	NONE	NONE	NONE	NONE	NONE	NONE
STRUCTURAL MISMATCH	NONE	NONE	NONE	NONE	NONE	NONE	NONE	NONE	NONE
STME OUT	+Z @ 4.75	+Y @ 4.75	+Z @ 4.75	N/A	N/A	+Z @ 4.75	+Z @ 4.75	+Z @ 4.75	+Y @ 4.75
TIME BETWEEN SRB IGNITION AND STME OUT	N/A	N/A	N/A	N/A	N/A	N/A	N/A	N/A	N/A

* - SHUTDOWN OCCURS @ 4.75 SEC.

** - SHUTDOWN OCCURS @ 4.75 SEC. WITH A .1 SEC. PLATEAU

NLS1 LIFTOFF LOAD CASES FOR CYCLE I DESIGN

CASE NAME --->	LC1009	LC1010	LC1011	LC1012	LC1013	LC1014	LC1015	LC1016
STME 1 IGNITION STAGGER (SECONDS)	0.0	0.0	0.0	0.0	0.0	0.0	0.0	0.0
STME 2 IGNITION STAGGER (SECONDS)	0.0	0.0	0.0	0.0	0.0	0.0	0.0	0.0
STME 3 IGNITION STAGGER (SECONDS)	0.0	0.0	0.0	0.0	0.0	0.0	0.0	0.0
STME 4 IGNITION STAGGER (SECONDS)	0.0	0.0	0.0	0.0	0.0	0.0	0.0	0.0
STME THRUST BUILD-UP DESCRIPTION	NOM	NOM	NOM	NOM	NOM	MAX	MAX	MAX
STME 1 IGNITION TIMING	0.0	0.0	0.0	0.0	0.0	0.0	0.0	0.0
STME 2 IGNITION TIMING	0.0	0.0	0.0	0.0	0.0	0.0	0.0	0.0
STME 3 IGNITION TIMING	0.0	0.0	0.0	0.0	0.0	0.0	0.0	0.0
STME 4 IGNITION TIMING	0.0	0.0	0.0	0.0	0.0	0.0	0.0	0.0
STME THRUST MISALIGNMENT	N/A	N/A	N/A	N/A	N/A	N/A	N/A	N/A
STME IGNITION SIDELOADS MAGNITUDES	N/A	N/A	N/A	N/A	N/A	N/A	N/A	N/A
WIND DIRECTION (NO DISPERSIONS)	NONE	NONE	NONE	NONE	NONE	NONE	+Z DIR	+Y DIR
SRB IGNITION TIMING	NOM	NOM	NOM	+2 SIGMA	-2 SIGMA	+2 SIGMA	+2 SIGMA	+2 SIGMA
SRB THRUST RISE RATE	NOM	NOM	NOM	+2 SIGMA	-2 SIGMA	+2 SIGMA	+2 SIGMA	+2 SIGMA
SRB THRUST LEVEL	-2 SIGMA	NOM	NOM	+2 SIGMA	-2 SIGMA	+2 SIGMA	+2 SIGMA	+2 SIGMA
SRB IGNITION INTERVAL	NOM	-2 SIGMA	NOM	+2 SIGMA	-2 SIGMA	+2 SIGMA	+2 SIGMA	+2 SIGMA
SRB THRUST MISMATCH	N/A	N/A	-2 SIGMA	+2 SIGMA	-2 SIGMA	+2 SIGMA	+2 SIGMA	+2 SIGMA
SRB THRUST MISALIGNMENT	N/A	N/A	N/A	N/A	N/A	N/A	N/A	N/A
SRB THRUST OFFSET	N/A	N/A	N/A	N/A	N/A	N/A	N/A	N/A
SRB IGNITION OVERPRESSURE	NOM	NOM	NOM	NOM	NOM	+2SIGMA	+2SIGMA	+2SIGMA
SRB IOP TIMING TOLERANCE (SECONDS)	N/A	N/A	N/A	N/A	N/A	N/A	N/A	N/A
SRB GROWTH	NOM	NOM	NOM	NOM	NOM	NOM	NOM	NOM
HOLDOWN BOLT TIMING	NONE	NONE	NONE	NONE	NONE	NONE	NONE	NONE
STRUCTURAL MISMATCH	NONE	NONE	NONE	NONE	NONE	NONE	NONE	NONE
STME OUT	N/A	N/A	N/A	N/A	N/A	N/A	N/A	N/A
TIME BETWEEN SRB IGNITION AND STME OUT	N/A	N/A	N/A	N/A	N/A	N/A	N/A	N/A

NLS1 LIFTOFF LOAD CASES FOR CYCLE I DESIGN

CASE NAME -->	LC1017	LC1018	LC1019	LC1020	LC1021	LC1022	LC1023	LC1024
STME 1 IGNITION STAGGER (SECONDS)	0.0							
STME 2 IGNITION STAGGER (SECONDS)	0.0							
STME 3 IGNITION STAGGER (SECONDS)	0.0							
STME 4 IGNITION STAGGER (SECONDS)	0.0							
STME THRUST BUILD-UP DESCRIPTION	MAX							
STME 1 IGNITION TIMING	0.0							
STME 2 IGNITION TIMING	0.0							
STME 3 IGNITION TIMING	0.0							
STME 4 IGNITION TIMING	0.0							
STME THRUST MISALIGNMENT	N/A							
STME IGNITION SIDELOADS MAGNITUDES	N/A							
WIND DIRECTION (NO DISPERSIONS)	+Z DIR							
SRB IGNITION TIMING	+2 SIGMA							
SRB THRUST RISE RATE	+2 SIGMA							
SRB THRUST LEVEL	+2 SIGMA							
SRB IGNITION INTERVAL	+2 SIGMA							
SRB THRUST MISMATCH	+2 SIGMA							
SRB THRUST MISALIGNMENT	N/A							
SRB THRUST OFFSET	N/A							
SRB IGNITION OVERPRESSURE	+2 SIGMA							
SRB JOP TIMING TOLERANCE (SECONDS)	N/A							
SRB GROWTH	NOM							
HOLDDOWN BOLT TIMING	NONE							
STRUCTURAL MISMATCH	NONE							
STME OUT	+Z ENGINE							
TIME BETWEEN SRB IGNITION AND STME OUT	0.0							

**NLS2 1.5 STAGE LAUNCH VEHICLE
BUILDUP/SHUTDOWN LOAD CASES FOR CYCLE I DESIGN**

CASE NAME --->	BUSD01	BUSD02	BUSD03	BUSD04	BUSD05	BUSD06	BUSD07	BUSD17
STME 1 IGNITION STAGGER (SECONDS)	0.0	0.0	0.0	0.0	0.0	0.0	0.0	0.0
STME 2 IGNITION STAGGER (SECONDS)	0.0	0.0	0.0	0.0	0.0	0.0	0.0	0.0
STME 3 IGNITION STAGGER (SECONDS)	0.0	0.0	0.0	0.0	0.0	0.0	0.0	0.0
STME 4 IGNITION STAGGER (SECONDS)	0.0	0.0	0.0	0.0	0.0	0.0	0.0	0.0
STME 5 IGNITION STAGGER (SECONDS)	0.0	0.0	0.0	0.0	0.0	0.0	0.0	0.0
STME 6 IGNITION STAGGER (SECONDS)	0.0	0.0	0.0	0.0	0.0	0.0	0.0	0.0
STME THRUST BUILD-UP DESCRIPTION	NDM	MIN	MAX	MAX	MAX	MAX	MAX	MAX
STME 1 IGNITION TIMING	0.0	0.0	0.0	0.0	0.0	0.0	0.0	0.0
STME 2 IGNITION TIMING	0.0	0.0	0.0	0.0	0.0	0.0	0.0	0.0
STME 3 IGNITION TIMING	0.0	0.0	0.0	0.0	0.0	0.0	0.0	0.0
STME 4 IGNITION TIMING	0.0	0.0	0.0	0.0	0.0	0.0	0.0	0.0
STME 5 IGNITION TIMING	0.0	0.0	0.0	0.0	0.0	0.0	0.0	0.0
STME 6 IGNITION TIMING	0.0	0.0	0.0	0.0	0.0	0.0	0.0	0.0
STME THRUST MISALIGNMENT	0.0°	0.0°	0.0°	0.0°	0.0°	+4° ABOUT Z	+4° ABOUT Y	0.0°
STME IGNITION SIDELOADS MAGNITUDES	N/A	N/A	N/A	N/A	N/A	N/A	N/A	N/A
WIND DIRECTION (NO DISPERSIONS)	NONE	NONE	NONE	Y-DIR	Z-DIR	Y-DIR	Z-DIR	NONE
HOLDOWN BOLT TIMING	NONE	NONE	NONE	NONE	NONE	NONE	NONE	NONE
STRUCTURAL MISMATCH	NONE	NONE	NONE	NONE	NONE	NONE	NONE	NONE
RELEASE TIMING	N/A	N/A	N/A	N/A	N/A	N/A	N/A	N/A
STME OUT	N/A	N/A	N/A	N/A	N/A	+Y @ 4.75	+Z @ 4.75	+Z @ 4.75

**NLS2 1.5 STAGE LAUNCH VEHICLE
LIFTOFF LOAD CASES FOR CYCLE I DESIGN**

CASE NAME ---->	LC1001	LC1002	LC1003	LC1004	LC1005	LC1006	LC1007	LC1017	LC1003A
STME 1 IGNITION STAGGER (SECONDS)	0.0	0.0	0.0	0.0	0.0	0.0	0.0	0.0	0.0
STME 2 IGNITION STAGGER (SECONDS)	0.0	0.0	0.0	0.0	0.0	0.0	0.0	0.0	0.0
STME 3 IGNITION STAGGER (SECONDS)	0.0	0.0	0.0	0.0	0.0	0.0	0.0	0.0	0.0
STME 4 IGNITION STAGGER (SECONDS)	0.0	0.0	0.0	0.0	0.0	0.0	0.0	0.0	0.0
STME 5 IGNITION STAGGER (SECONDS)	0.0	0.0	0.0	0.0	0.0	0.0	0.0	0.0	0.0
STME 6 IGNITION STAGGER (SECONDS)	0.0	0.0	0.0	0.0	0.0	0.0	0.0	0.0	0.0
STME THRUST BUILD-UP DESCRIPTION	NOM	MIN	MAX	MAX	MAX	MAX	MAX	MAX	MAX
STME 1 IGNITION TIMING	0.0	0.0	0.0	0.0	0.0	0.0	0.0	0.0	0.0
STME 2 IGNITION TIMING	0.0	0.0	0.0	0.0	0.0	0.0	0.0	0.0	0.0
STME 3 IGNITION TIMING	0.0	0.0	0.0	0.0	0.0	0.0	0.0	0.0	0.0
STME 4 IGNITION TIMING	0.0	0.0	0.0	0.0	0.0	0.0	0.0	0.0	0.0
STME 5 IGNITION TIMING	0.0	0.0	0.0	0.0	0.0	0.0	0.0	0.0	0.0
STME 6 IGNITION TIMING	0.0	0.0	0.0	0.0	0.0	0.0	0.0	0.0	0.0
STME THRUST MISALIGNMENT	0.0°	0.0°	0.0°	0.0°	0.0°	+4° ABOUT Z	+4° ABOUT Y	0.0°	0.0°
STME IGNITION SIDELOADS MAGNITUDE	N/A	N/A	N/A	N/A	N/A	N/A	N/A	N/A	N/A
WIND DIRECTION (NO DISPERSIONS)	NONE	NONE	NONE	Y-DIR	Z-DIR	Y-DIR	Z-DIR	NONE	NONE
HOLDOWN BOLT TIMING	NONE	NONE	NONE	NONE	NONE	NONE	NONE	NONE	NONE
STRUCTURAL MISMATCH	NONE	NONE	NONE	NONE	NONE	NONE	NONE	NONE	NONE
RELEASE TIMING	4.75 SEC	4.75 SEC	4.75 SEC	4.75 SEC	4.75 SEC	4.75 SEC	4.75 SEC	4.75 SEC	3.98 SEC
STME OUT	N/A	N/A	N/A	N/A	N/A	+Y @ 4.75	+Z @ 4.75	+Z @ 4.75	N/A

STME THRUST VS TIME
IGNITION AND SHUTDOWN CYCLE I LOADS

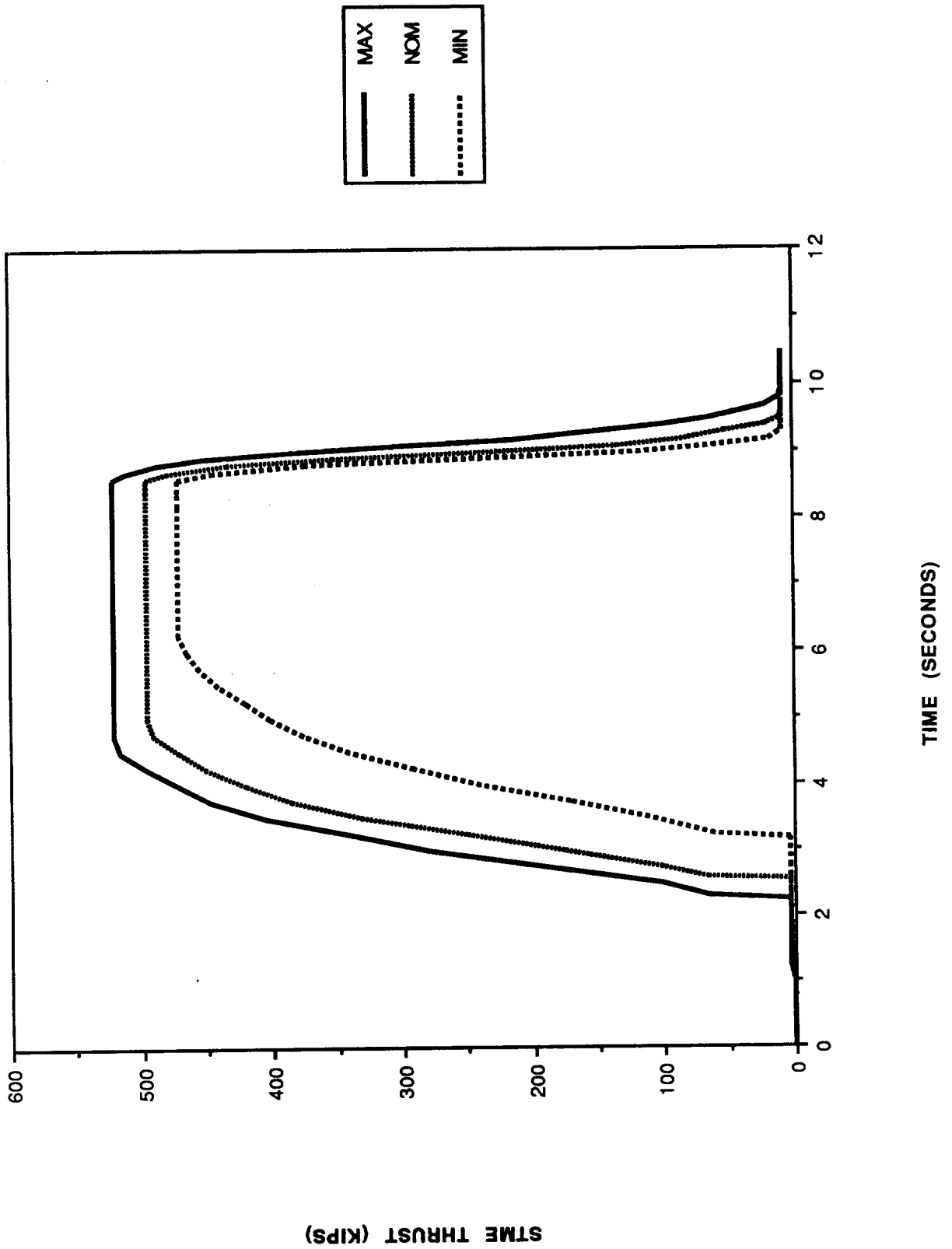

ASRM THRUST DATA A1 THRUST AND HEAD PRESSURE VS TIME

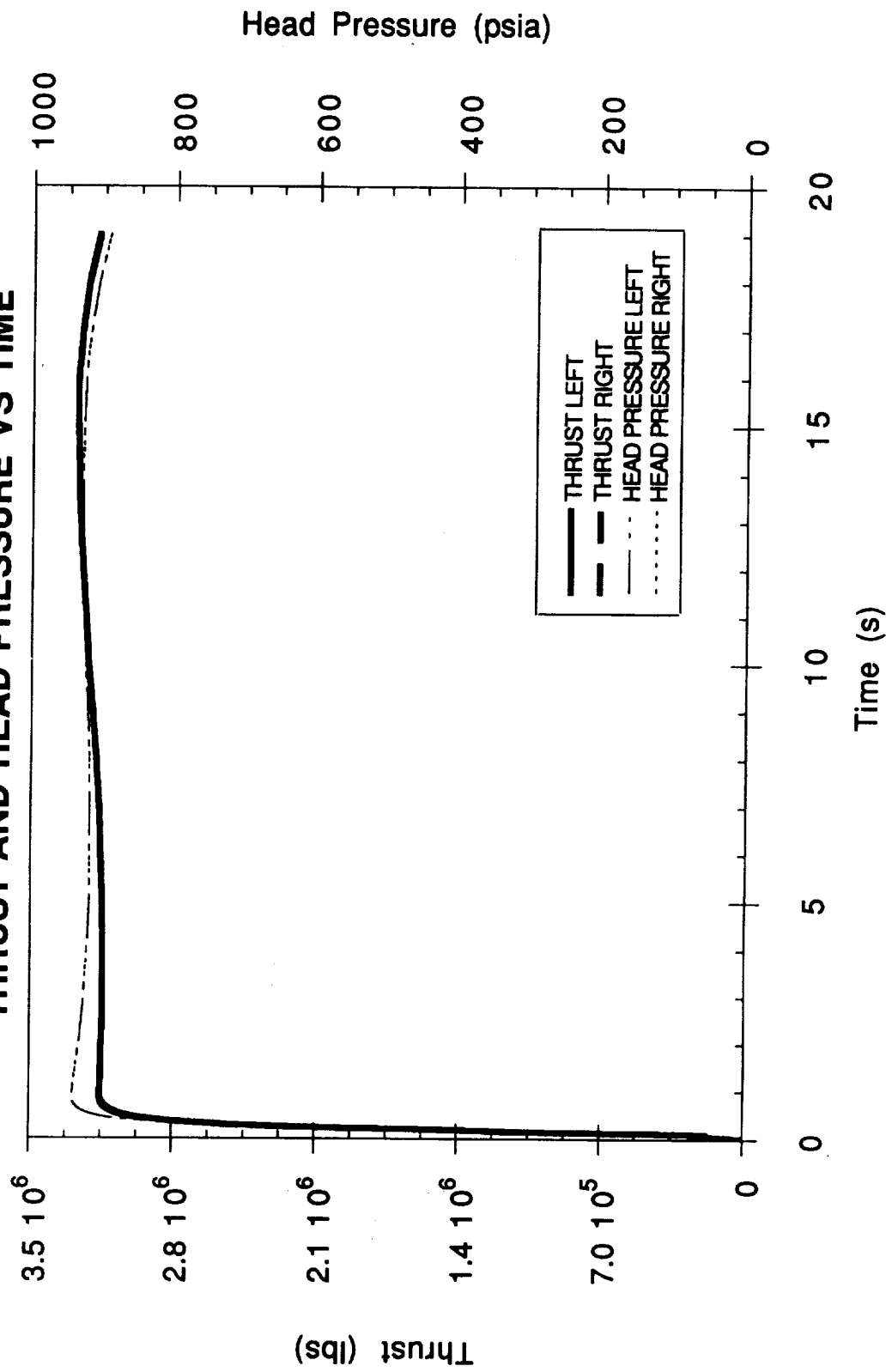

ASRM THRUST DATA A2 THRUST AND HEAD PRESSURE VS TIME

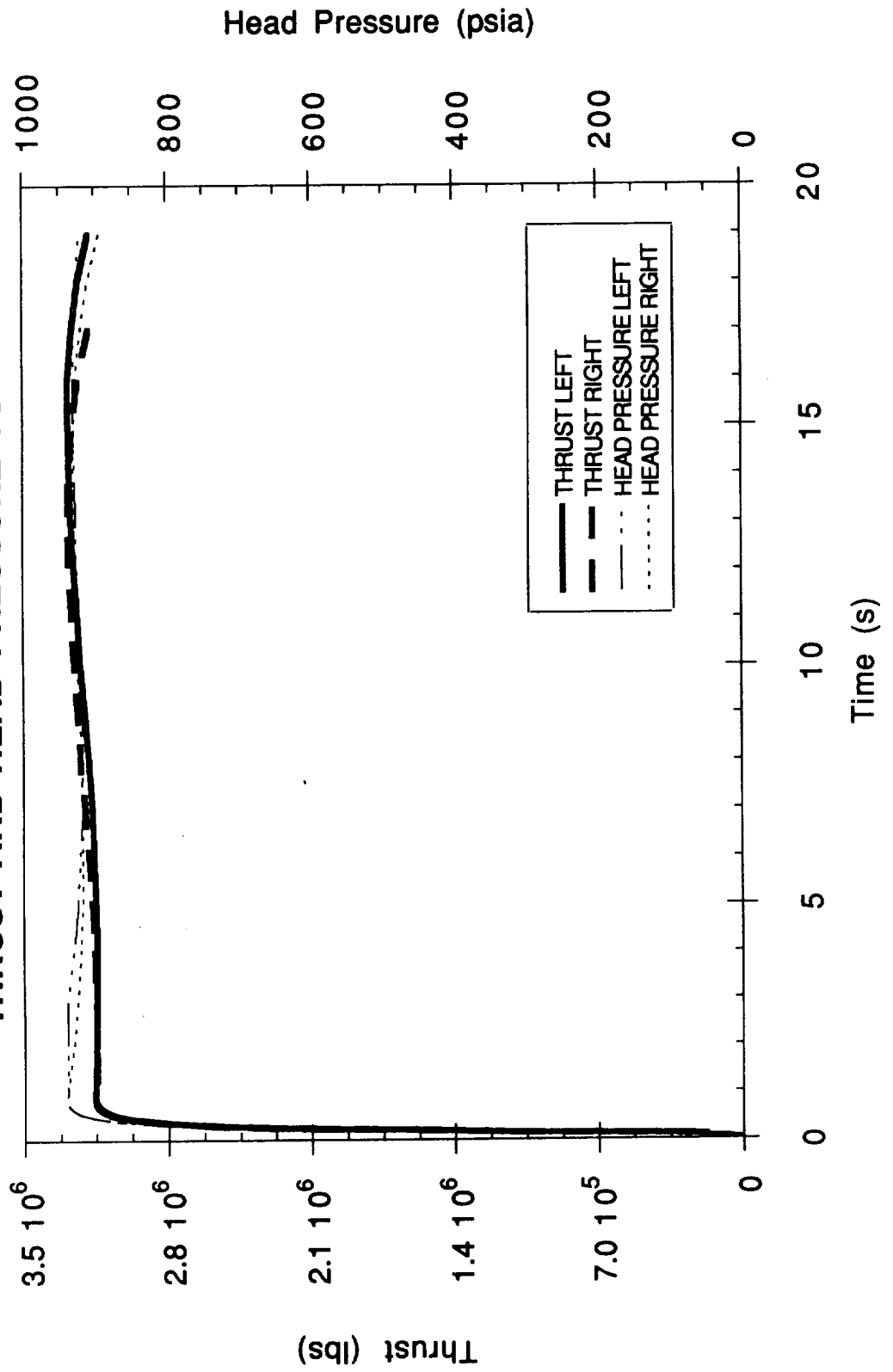

ASRM THRUST DATA A3 THRUST AND HEAD PRESSURE VS TIME

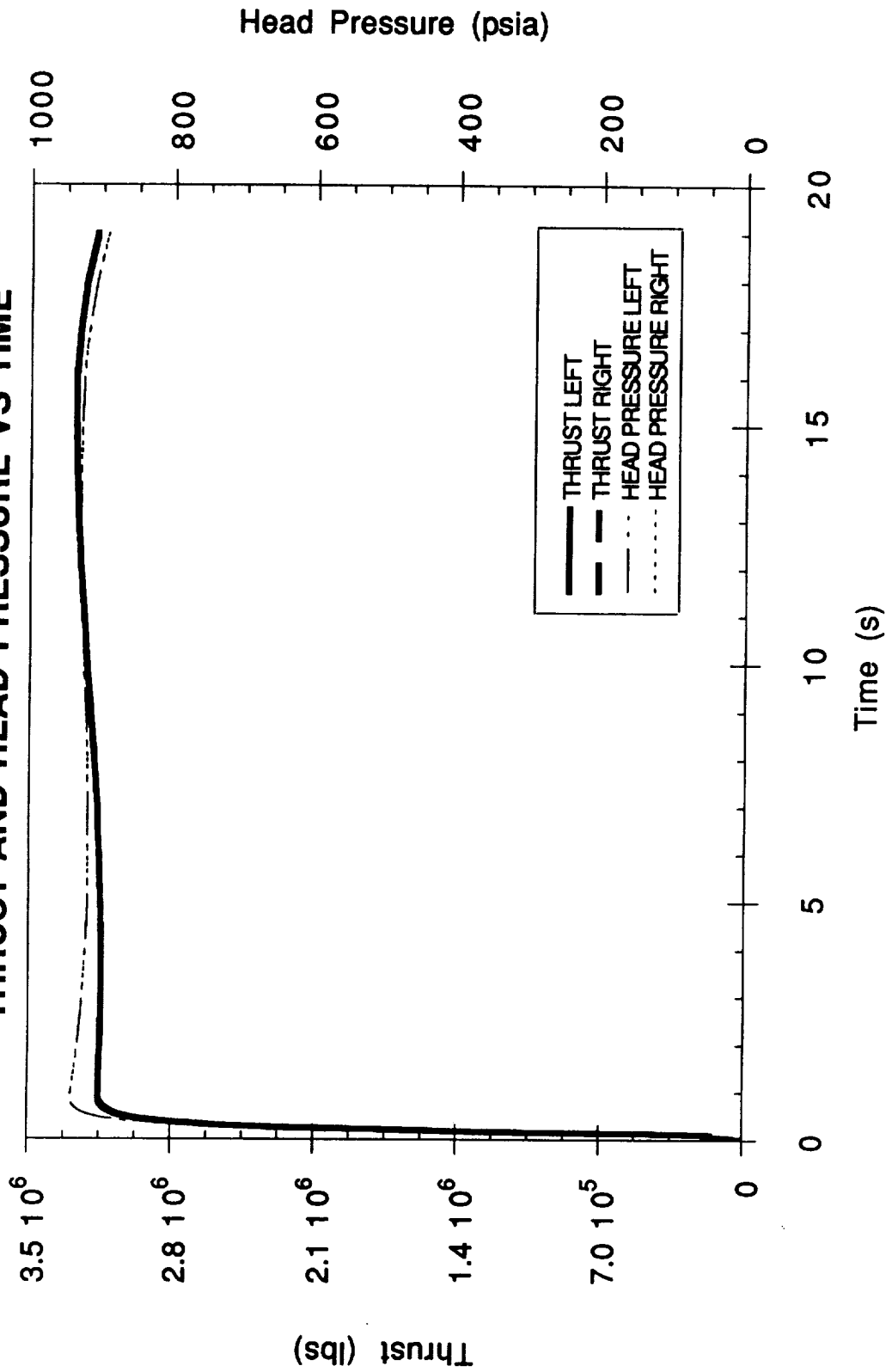

**ASRM THRUST DATA A4
THRUST AND HEAD PRESSURE VS TIME**

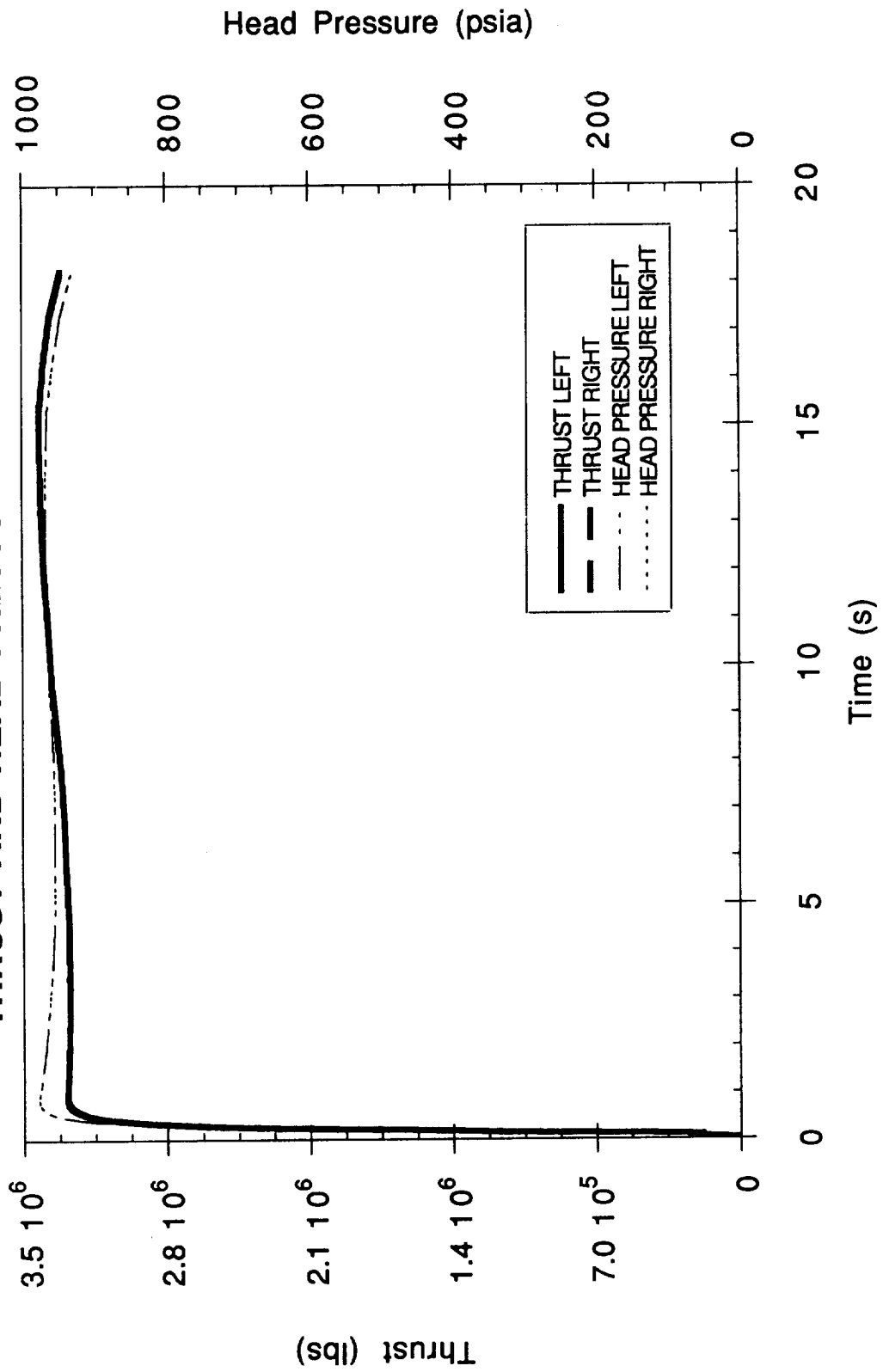

ASRM THRUST DATA A5 THRUST AND HEAD PRESSURE VS TIME

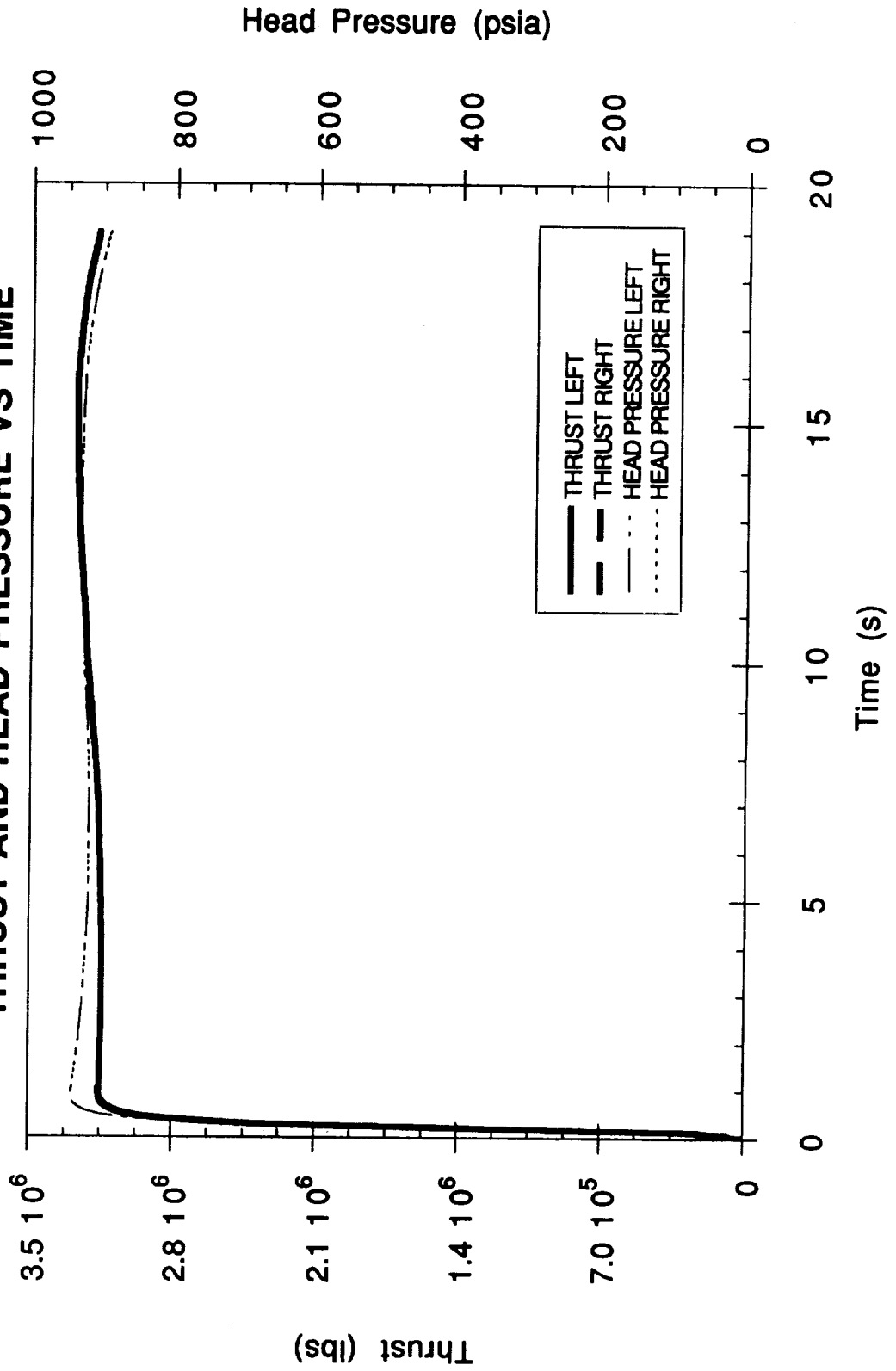

**ASRM THRUST DATA A6
THRUST AND HEAD PRESSURE VS TIME**

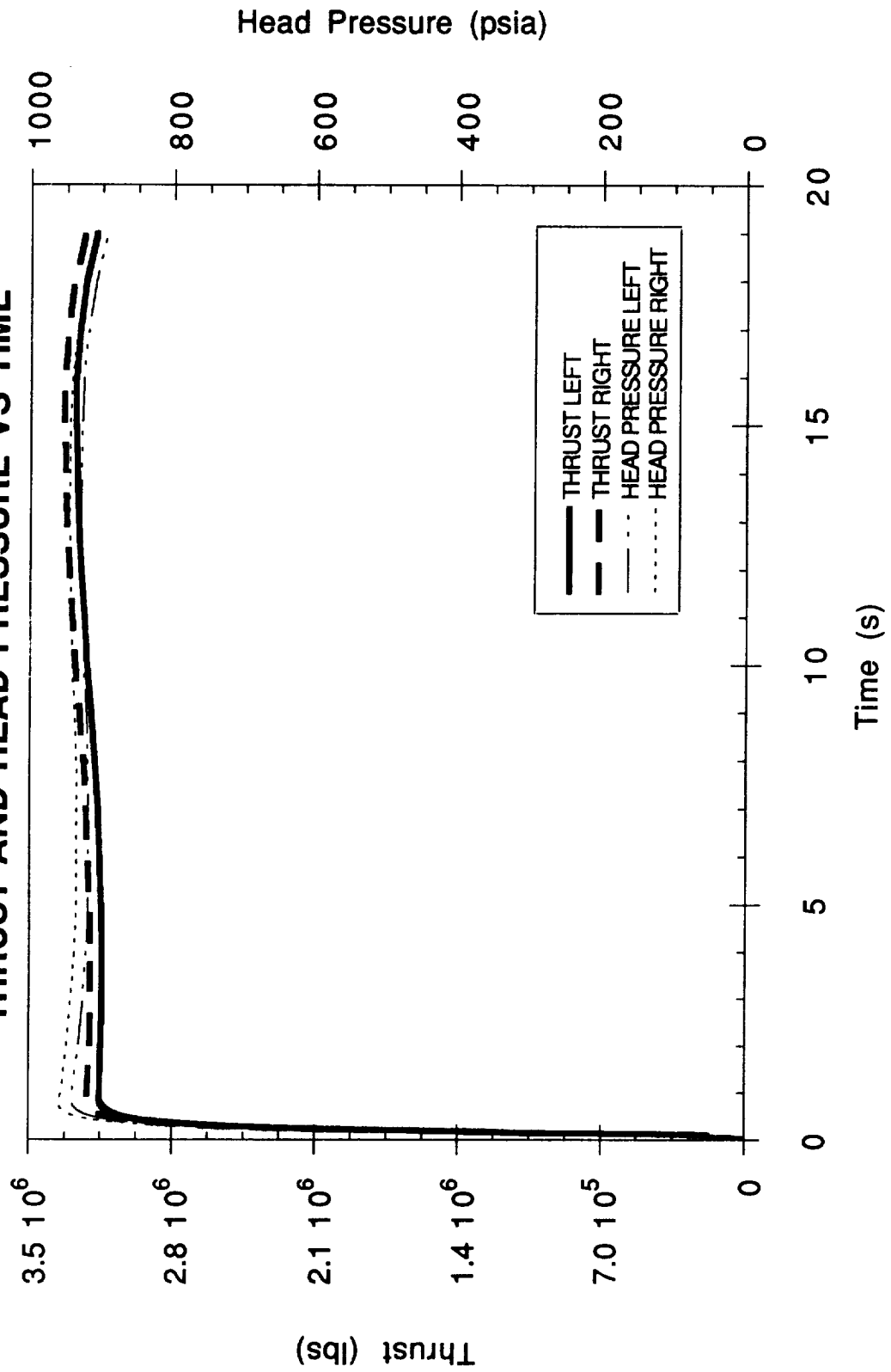

ASRM THRUST DATA A11 THRUST AND HEAD PRESSURE VS TIME

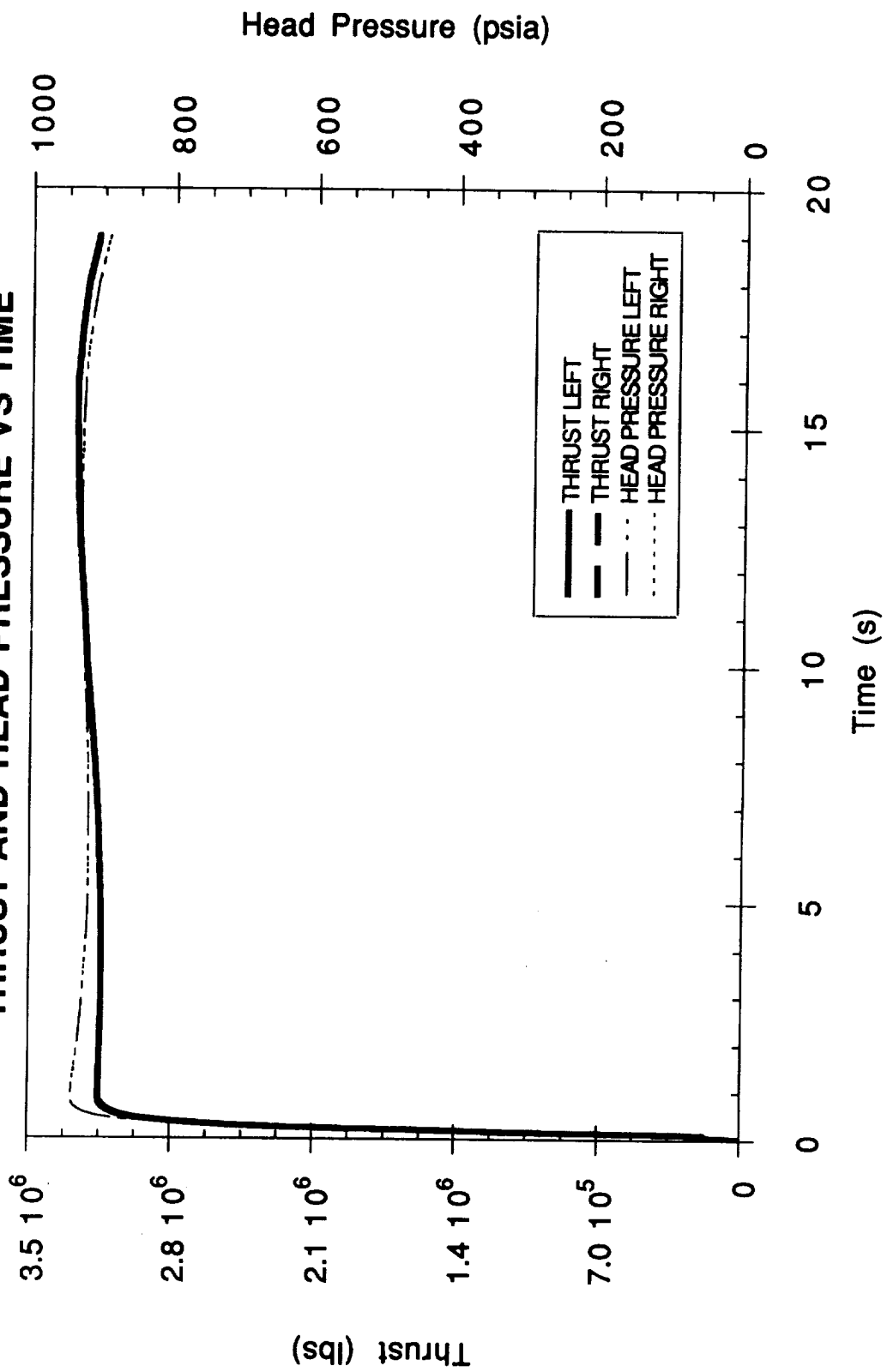

(

(

(

ASRM THRUST DATA A12 THRUST AND HEAD PRESSURE VS TIME

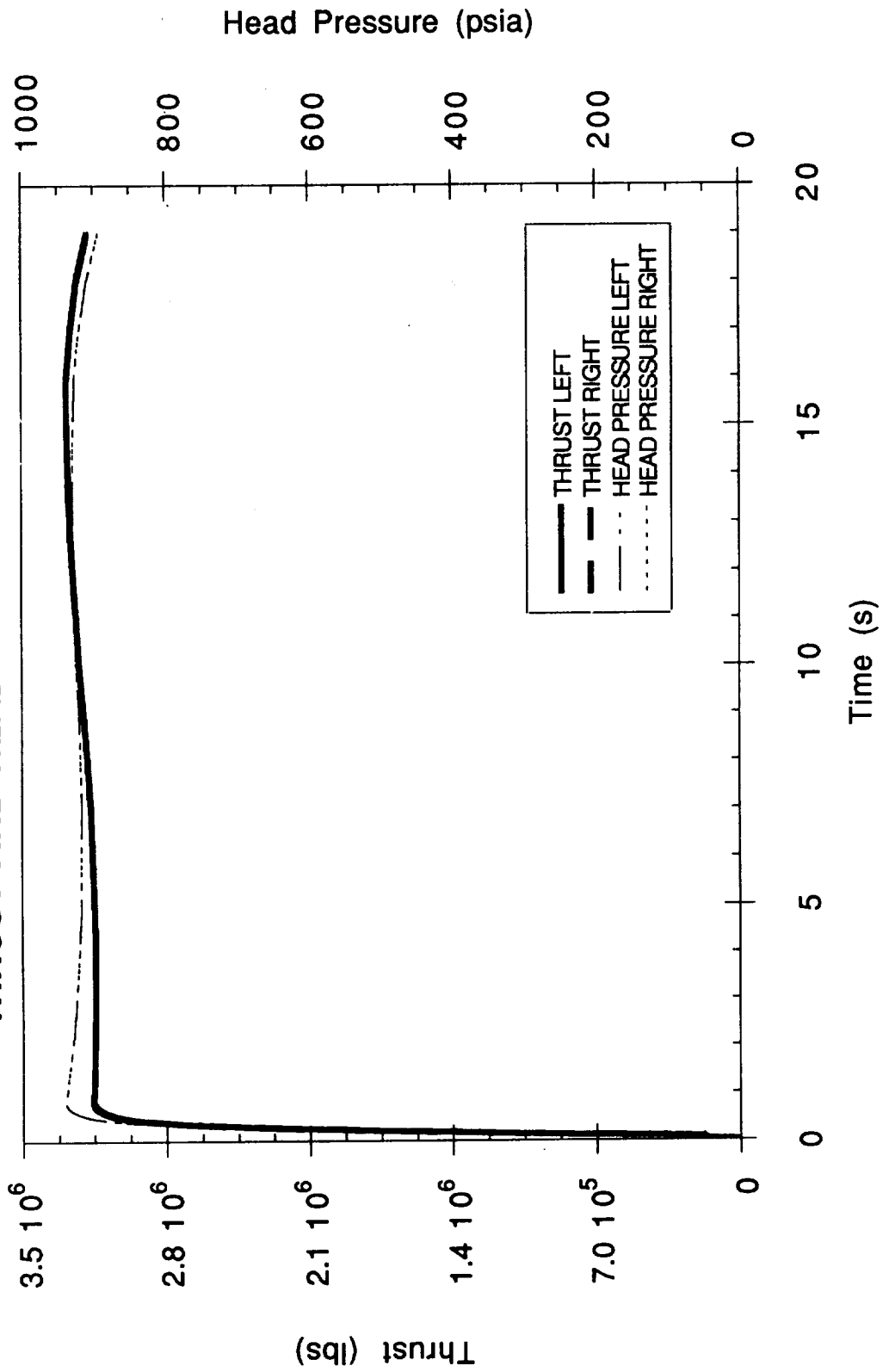

ASRM THRUST DATA A13 THRUST AND HEAD PRESSURE VS TIME

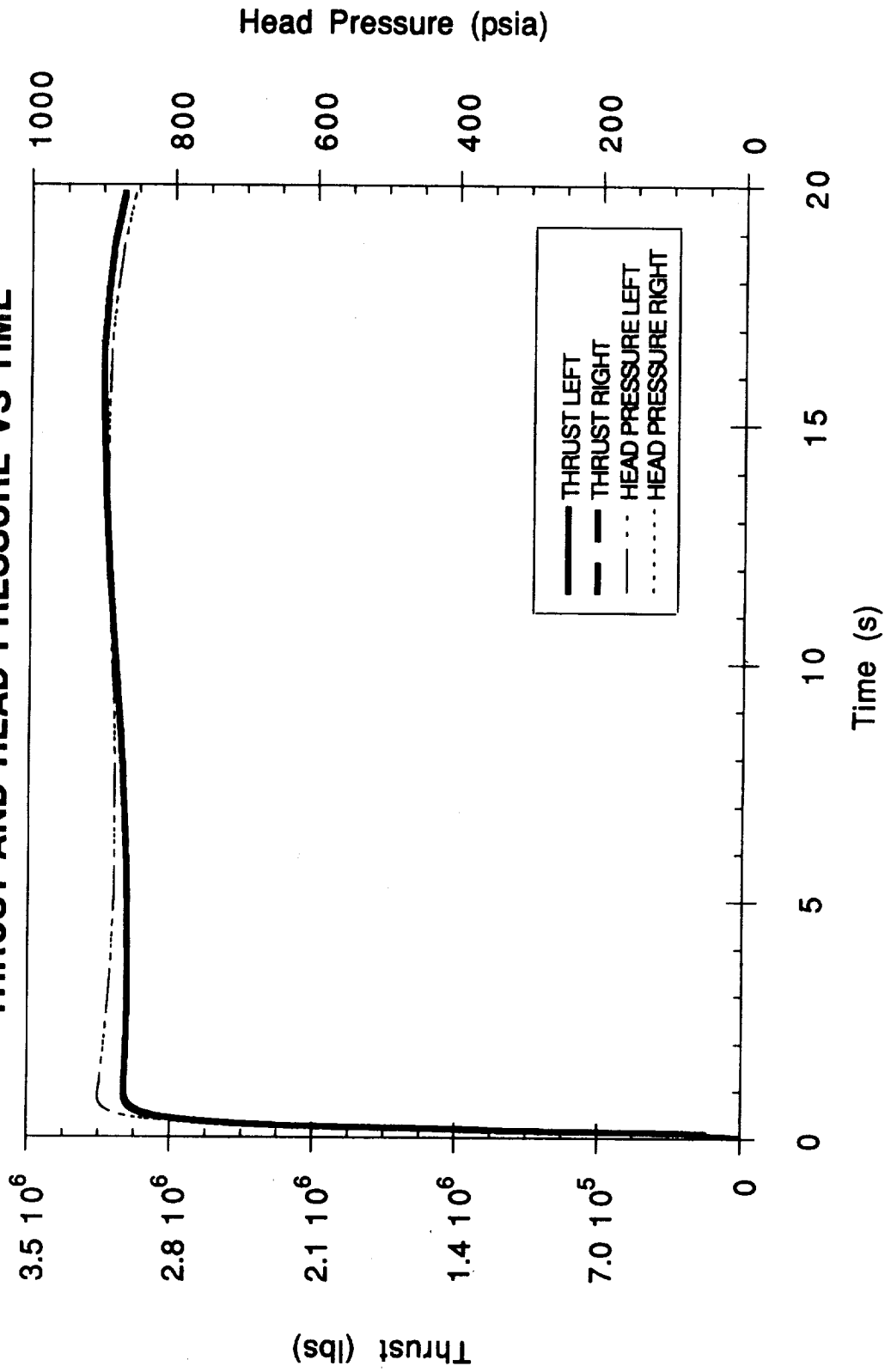

**ASRM THRUST DATA A14
THRUST AND HEAD PRESSURE VS TIME**

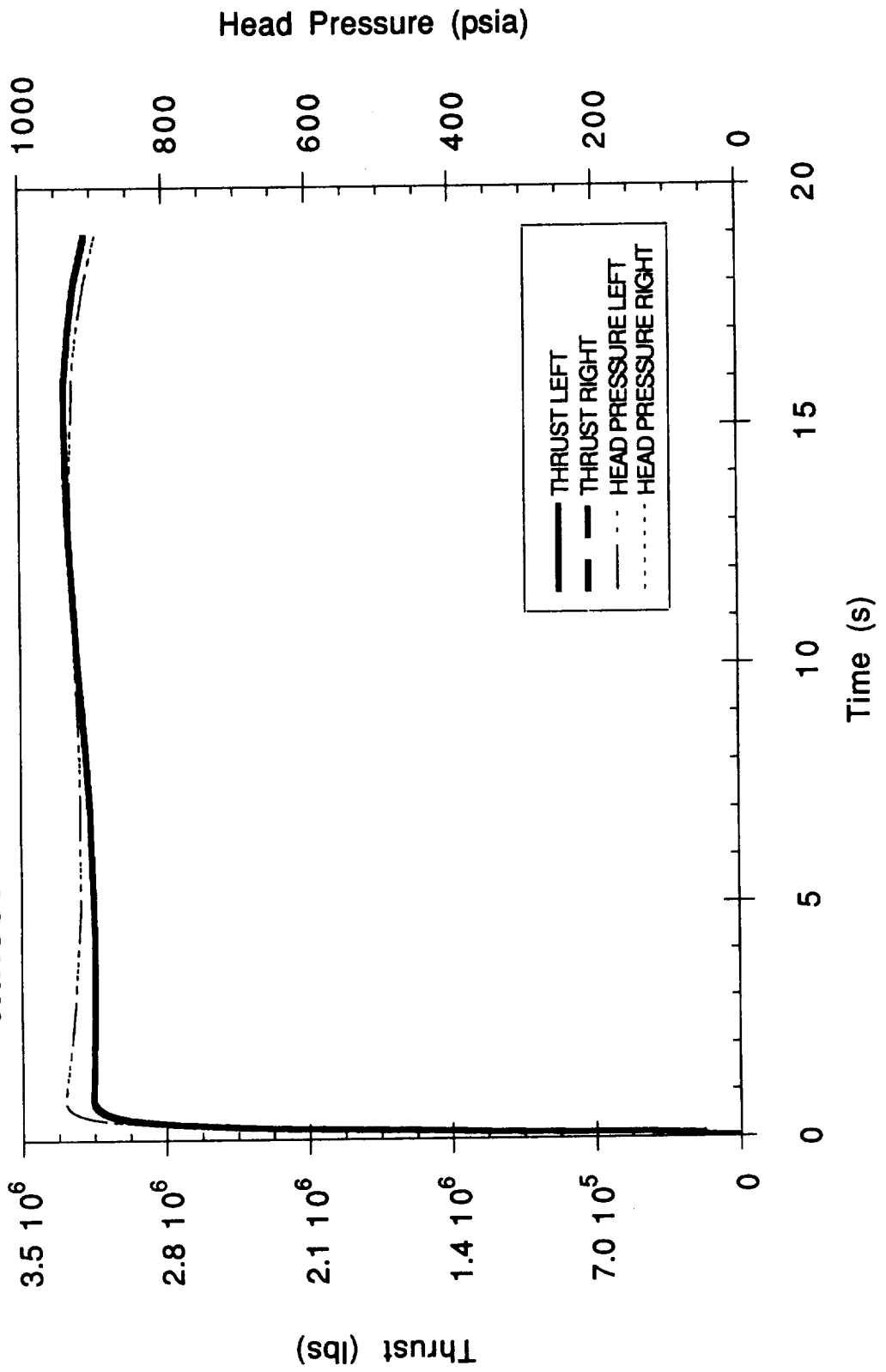

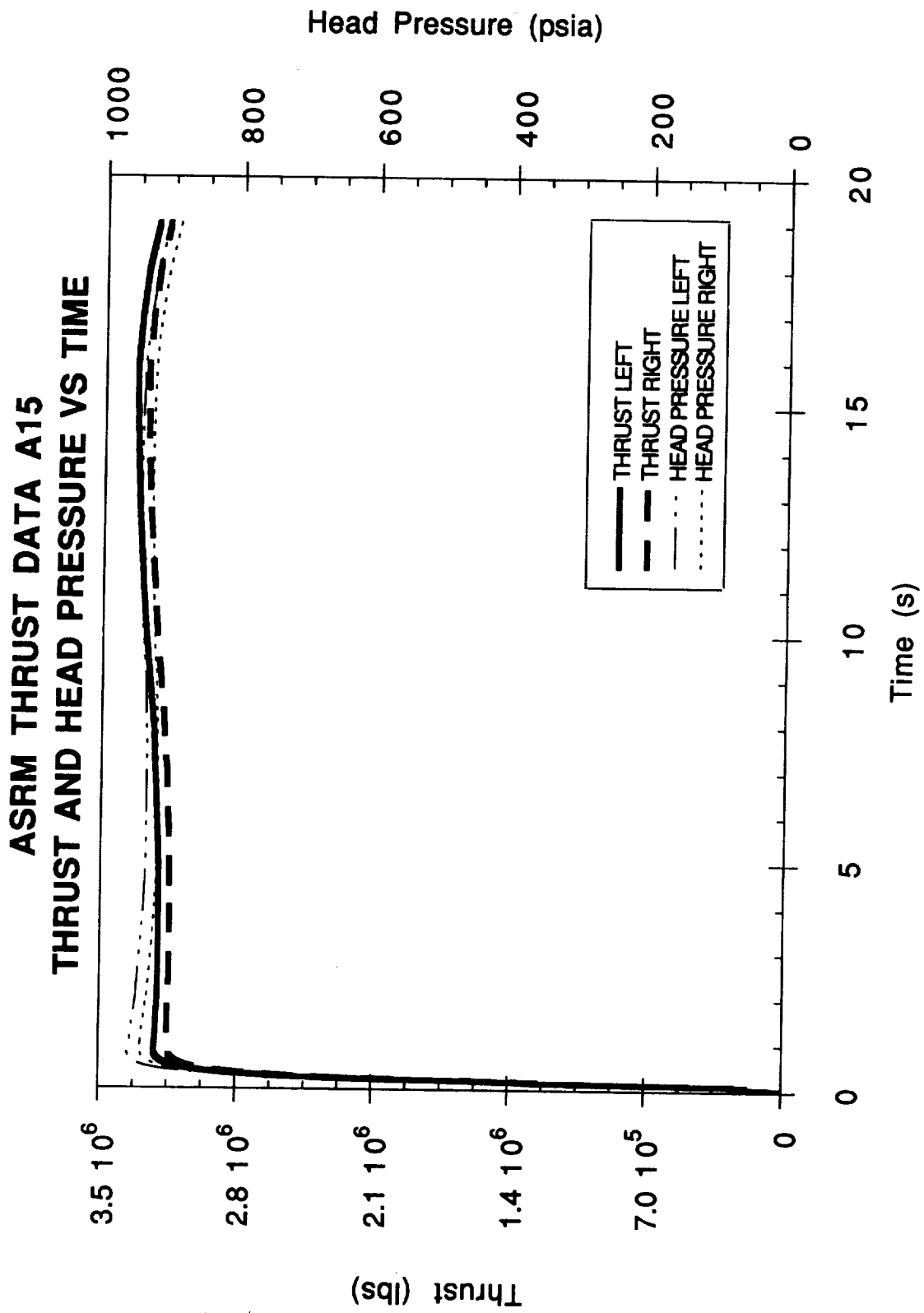

(

(

(

ASRM THRUST DATA A20 THRUST AND HEAD PRESSURE VS TIME

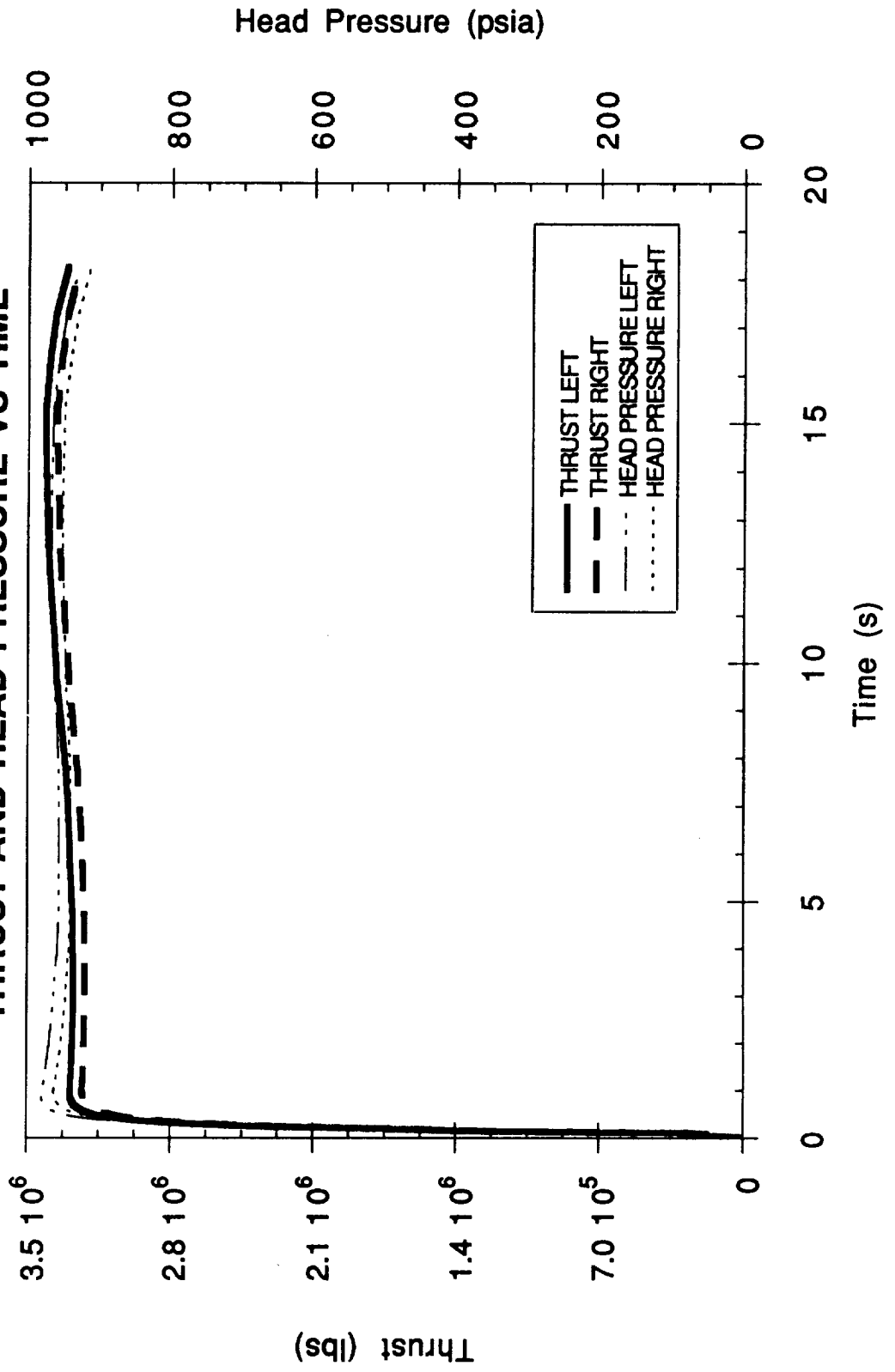

ASRM THRUST DATA A21 THRUST AND HEAD PRESSURE VS TIME

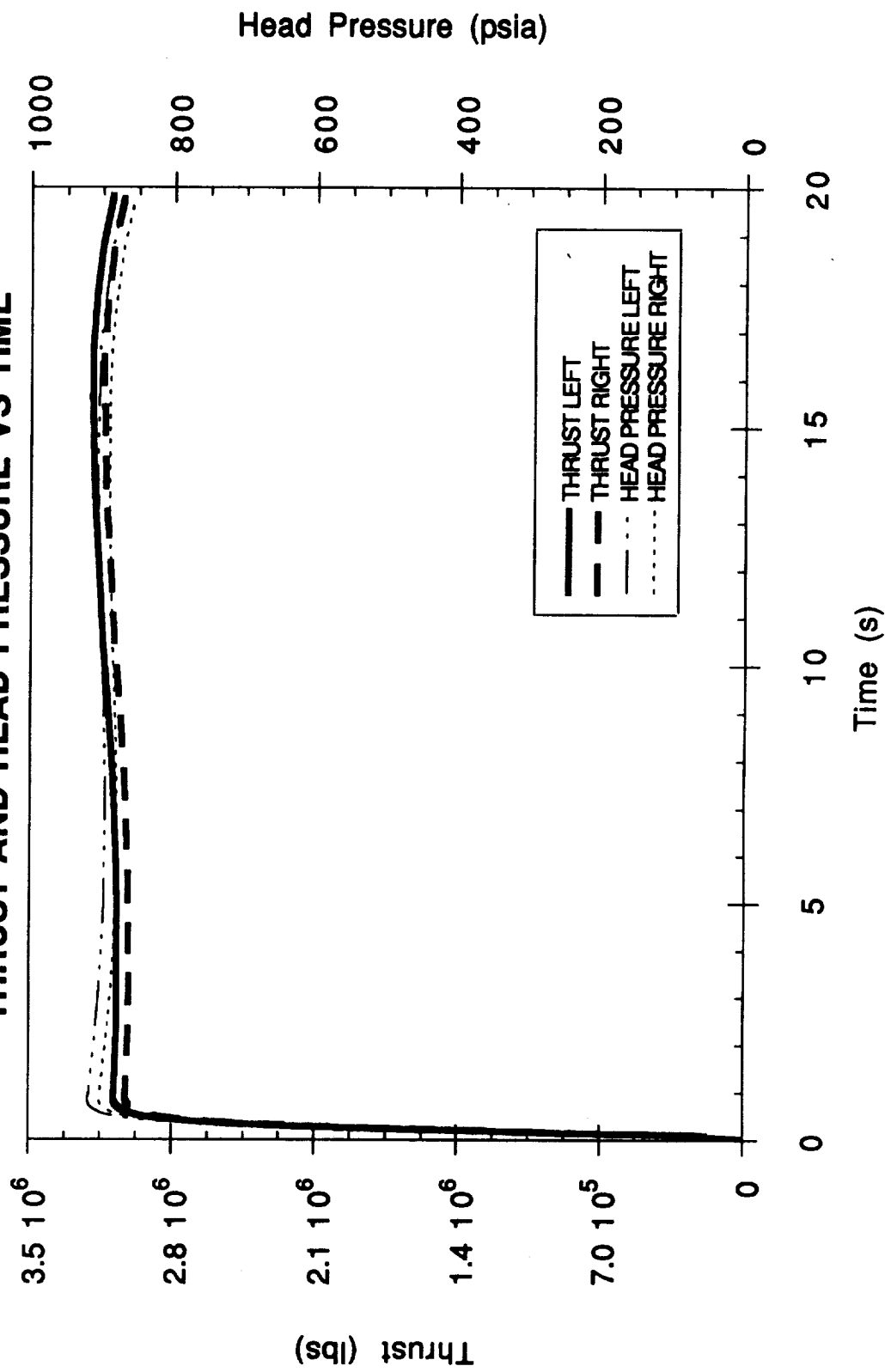

(

(

(

"OVERPRESSURE FORCES NOMINAL"

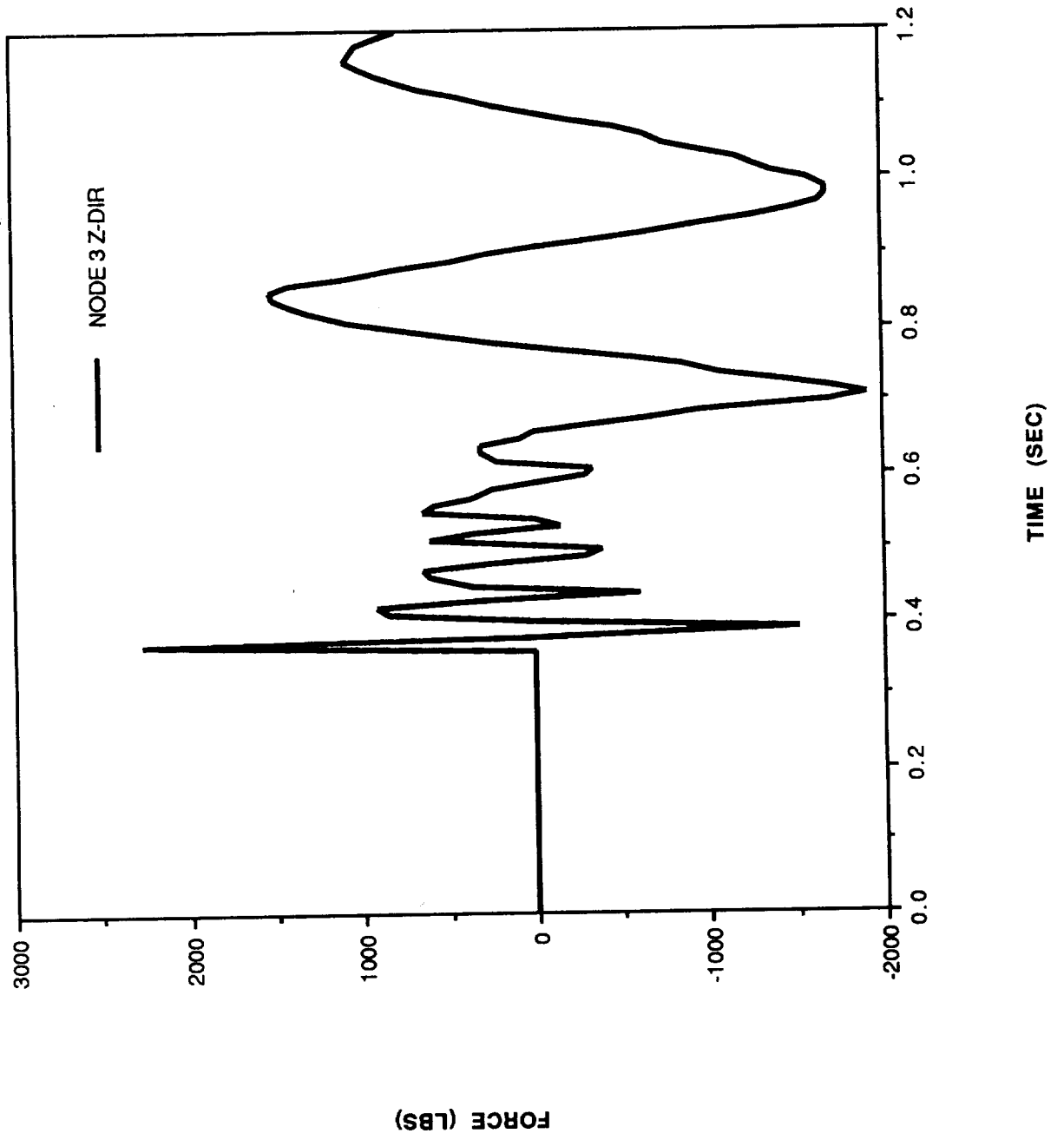

"OVERPRESSURE FORCES NOMINAL"

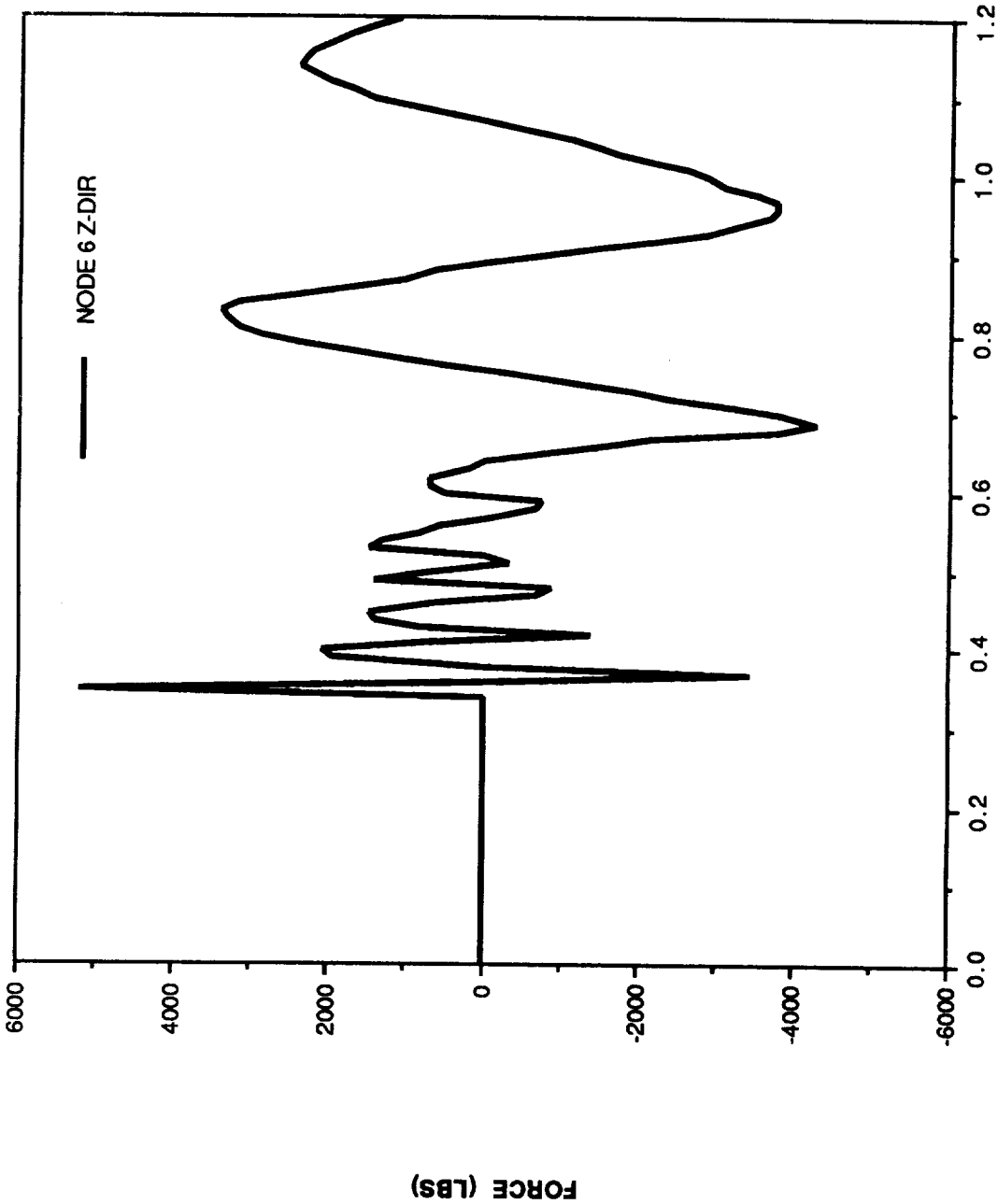

"OVERPRESSURE FORCES NOMINAL"

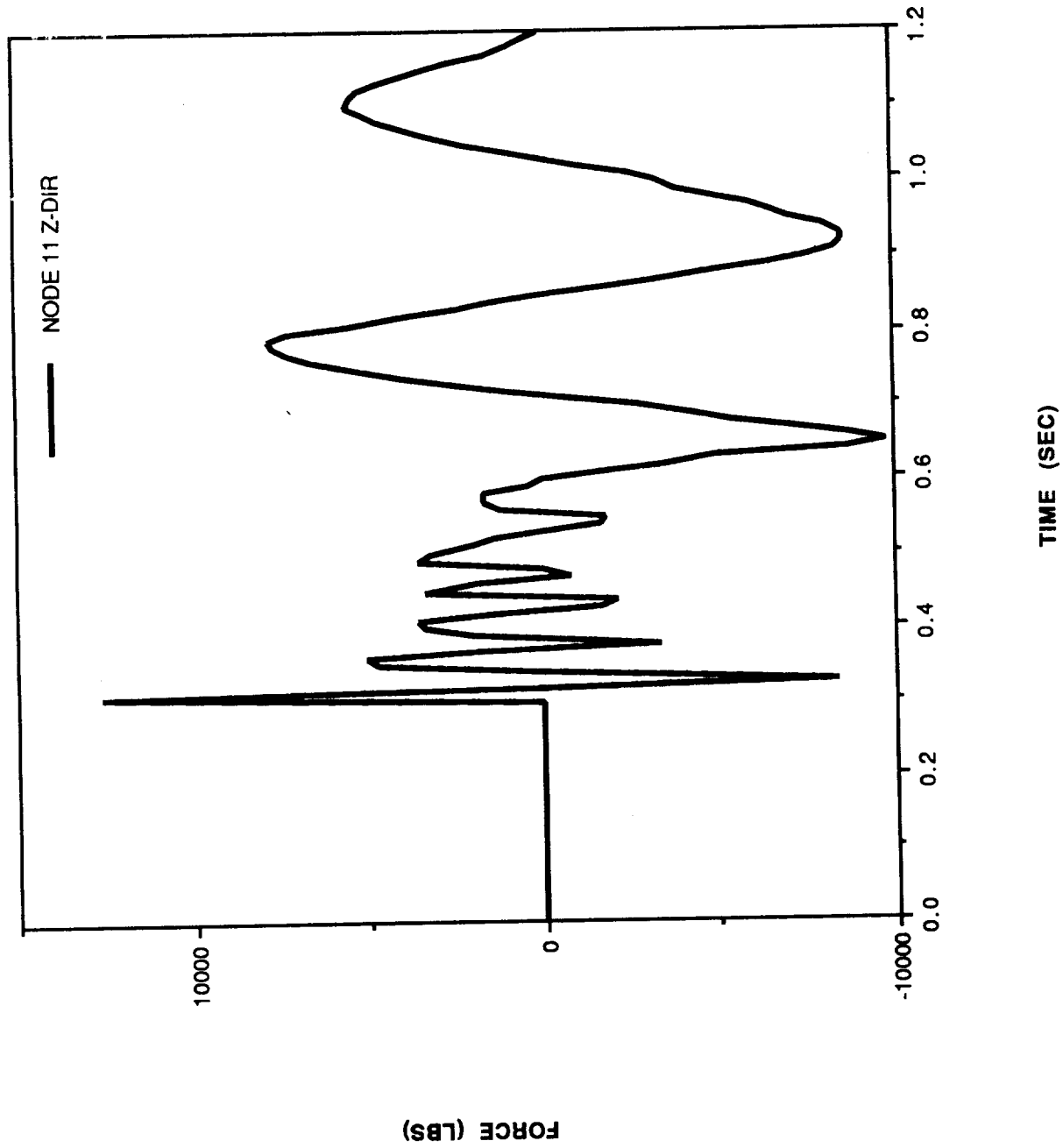

"OVERPRESSURE FORCES NOMINAL"

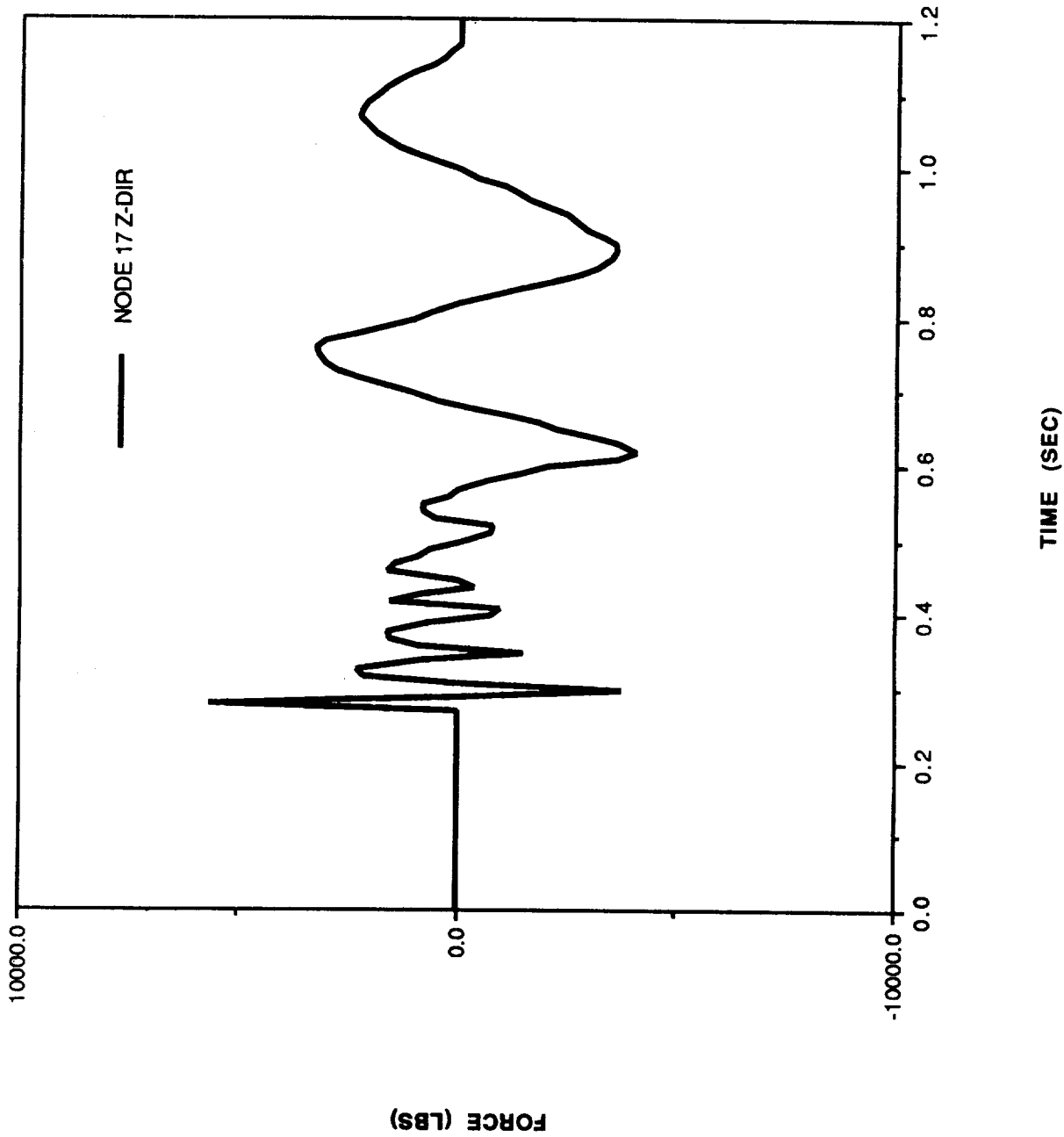

"OVERPRESSURE FORCES NOMINAL"

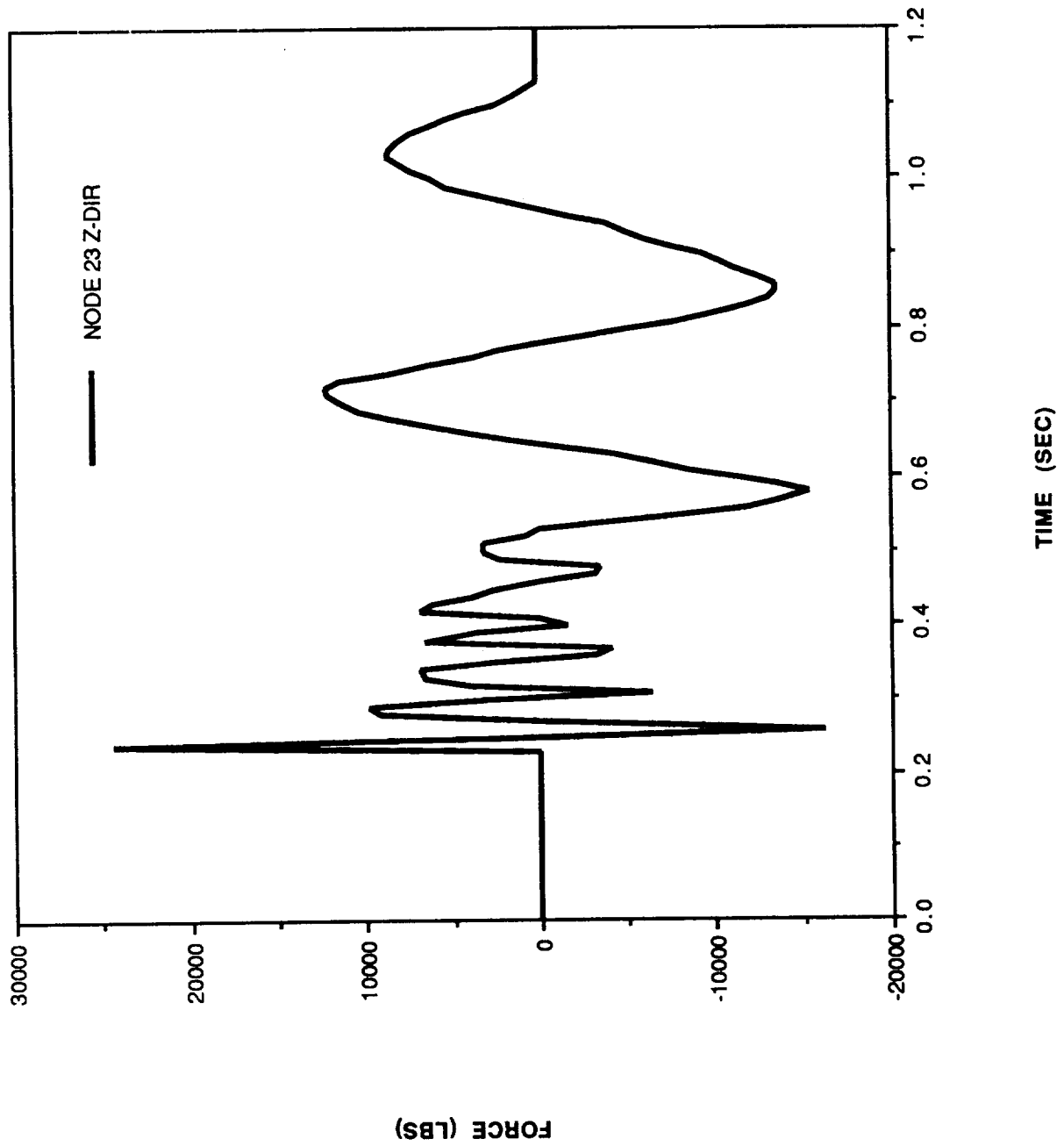

"OVERPRESSURE FORCES NOMINAL"

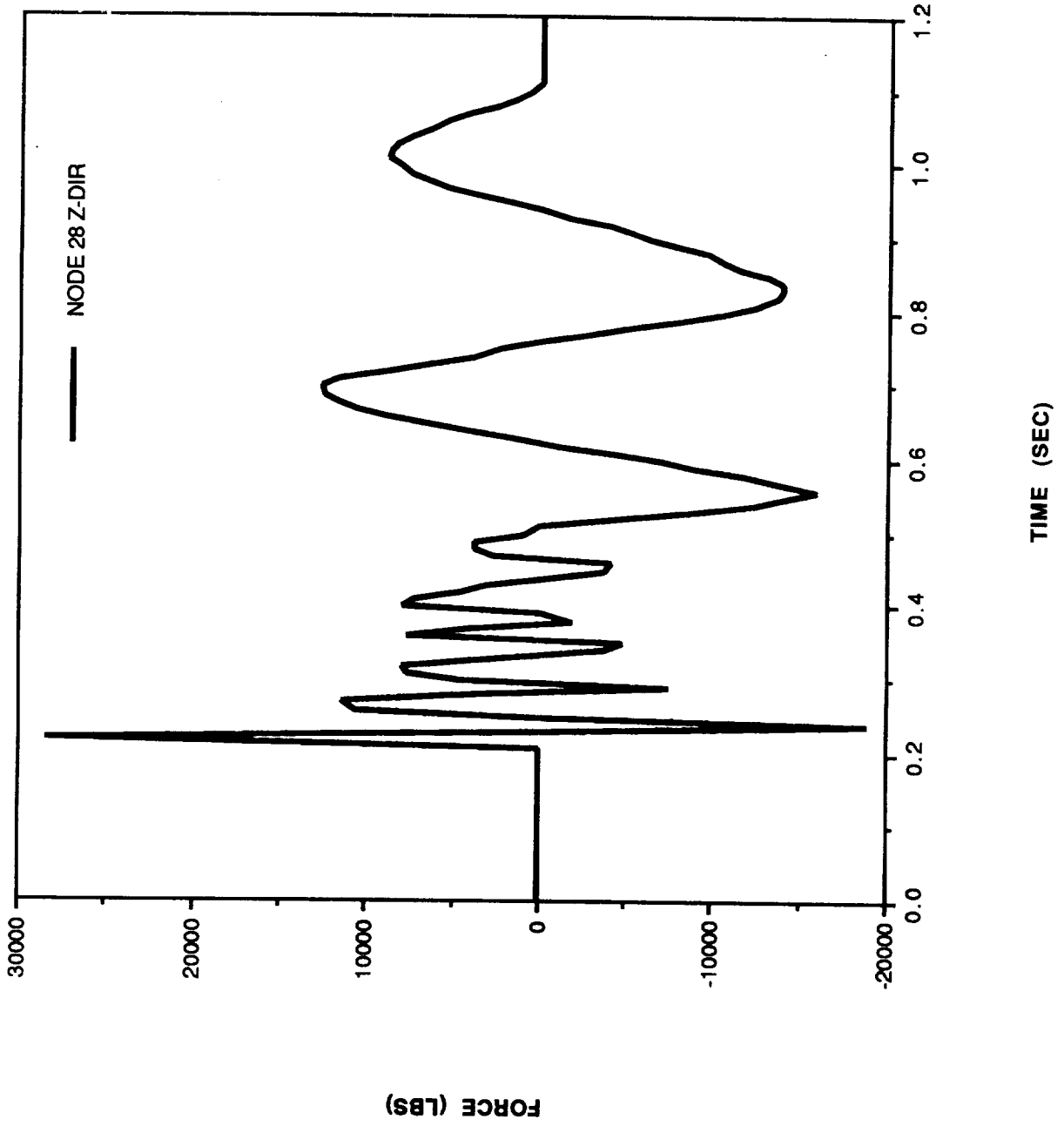

"OVERPRESSURE FORCES NOMINAL"

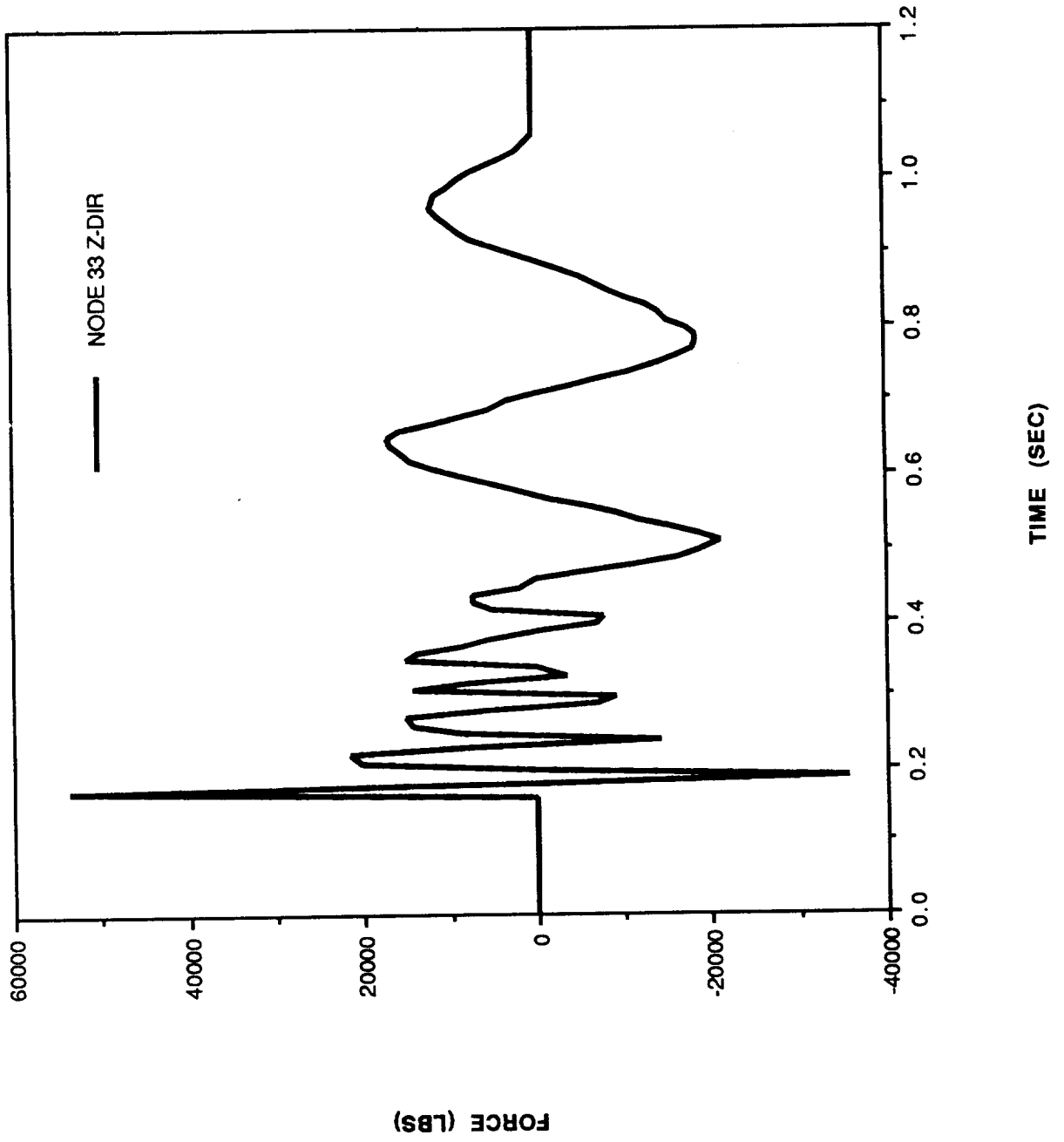

"OVERPRESSURE FORCES NOMINAL"

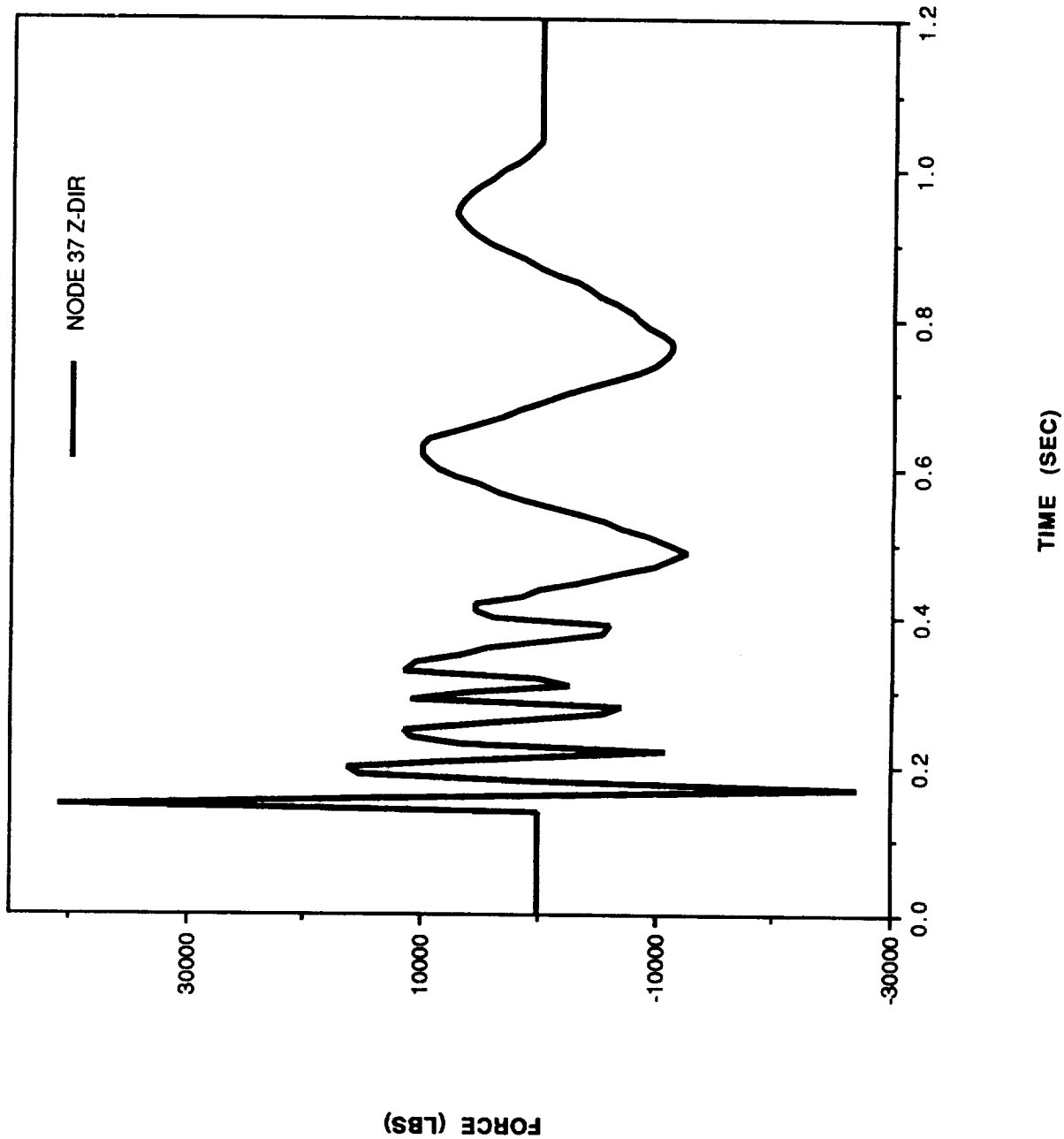

(

(

(

"OVERPRESSURE FORCES NOMINAL"

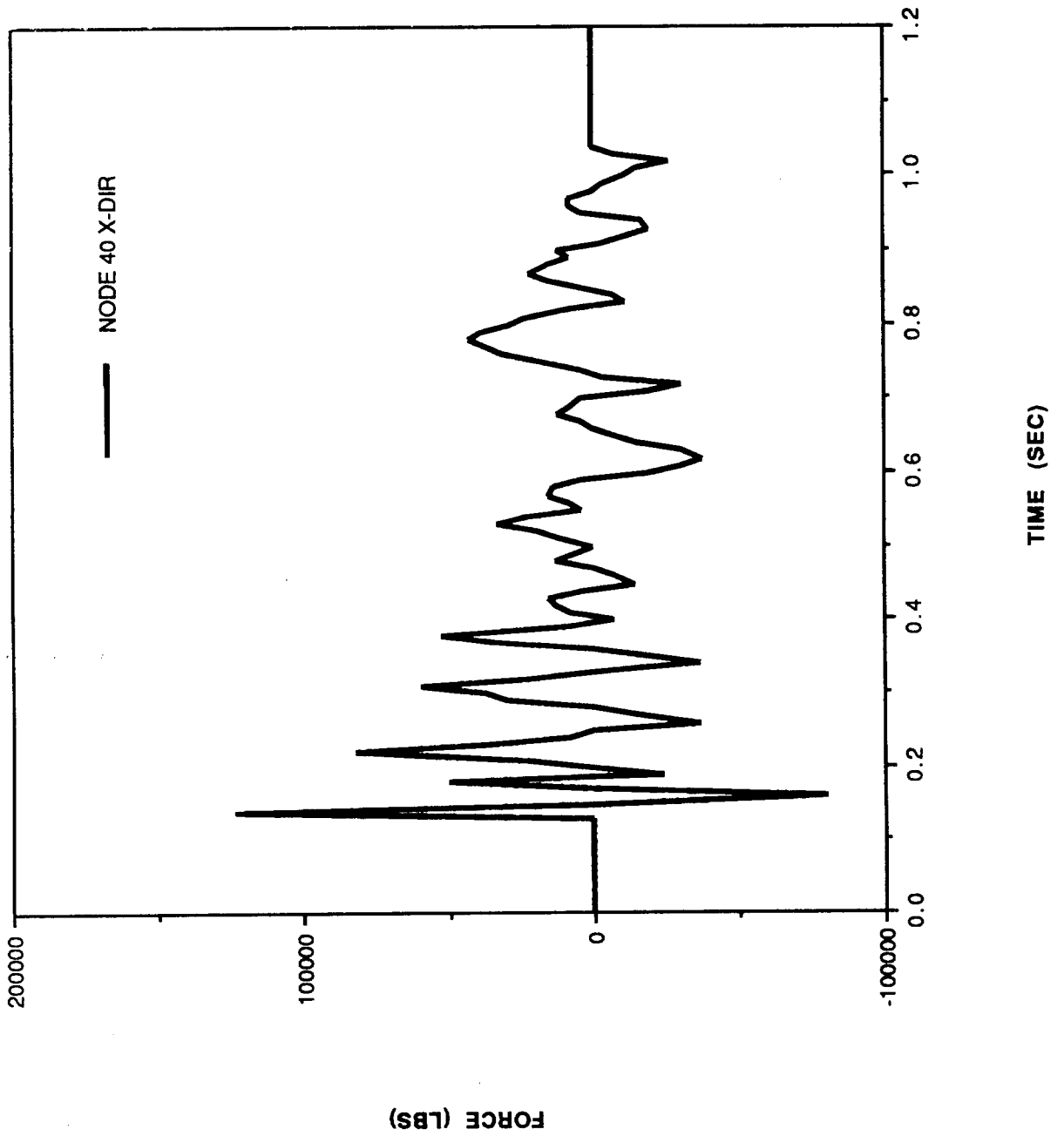

"OVERPRESSURE FORCES NOMINAL"

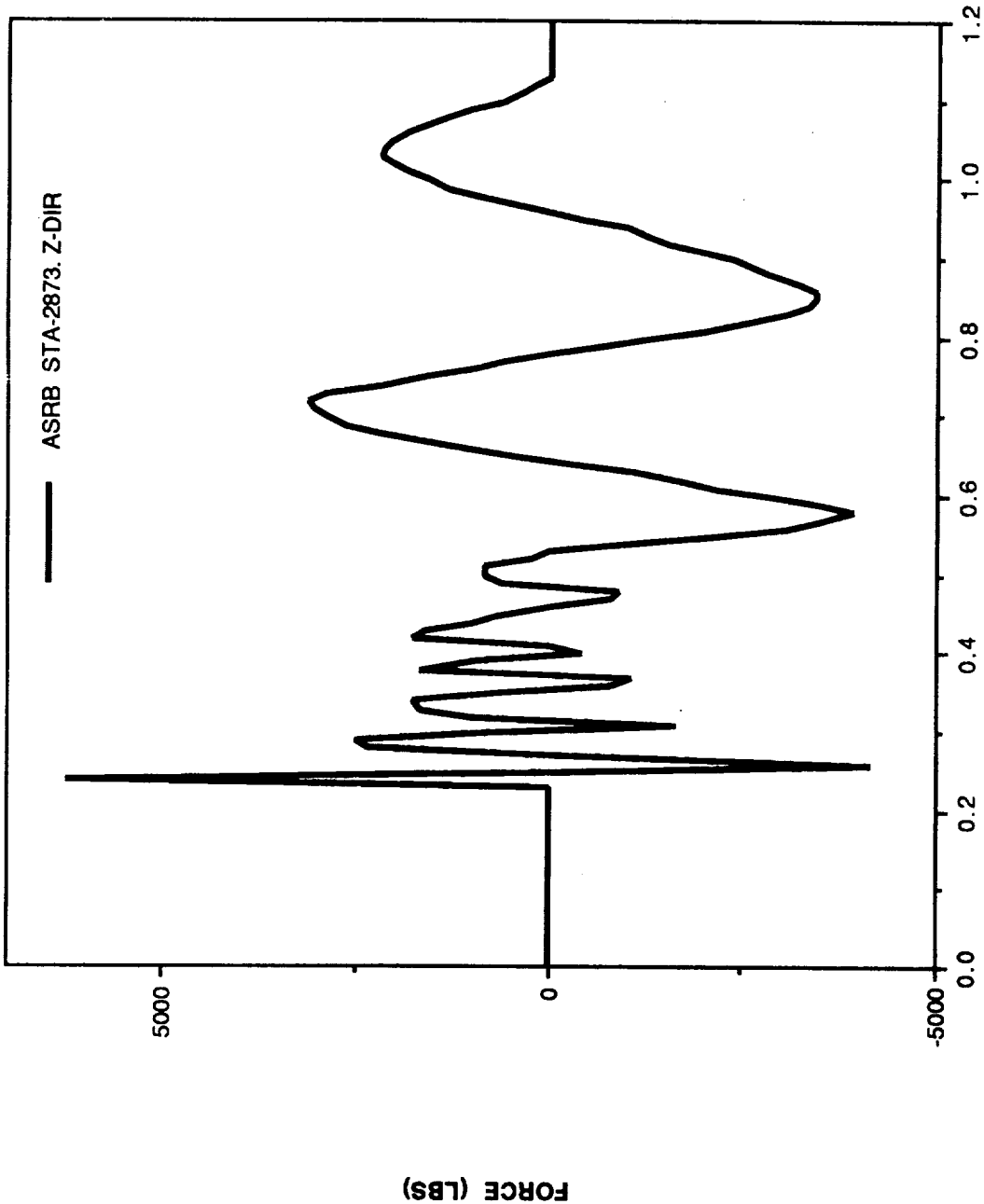

TIME (SEC)

FORCE (LBS)

ASRB STA-2873. Z-DIR

"OVERPRESSURE FORCES NOMINAL"

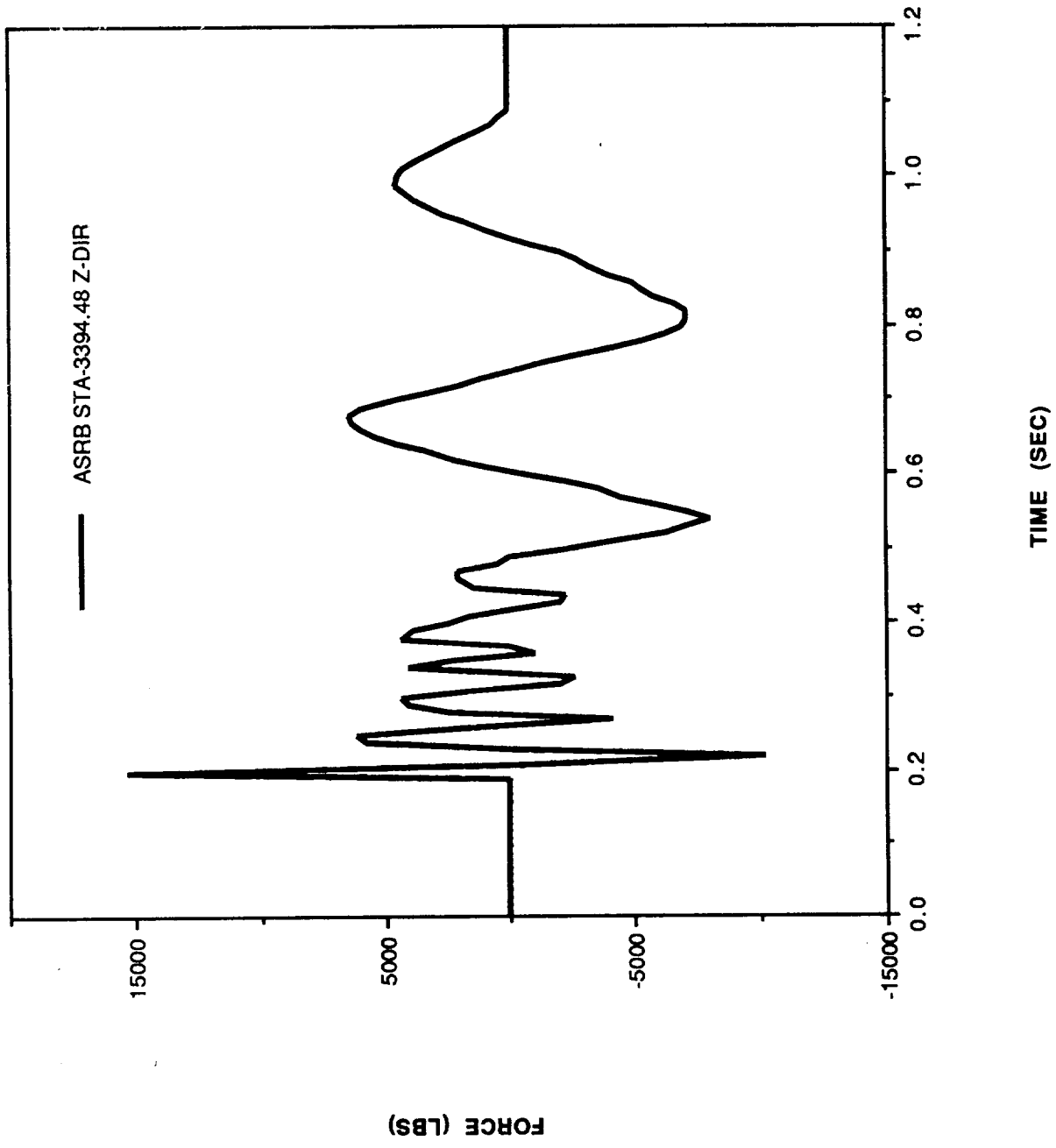

"OVERPRESSURE FORCES NOMINAL"

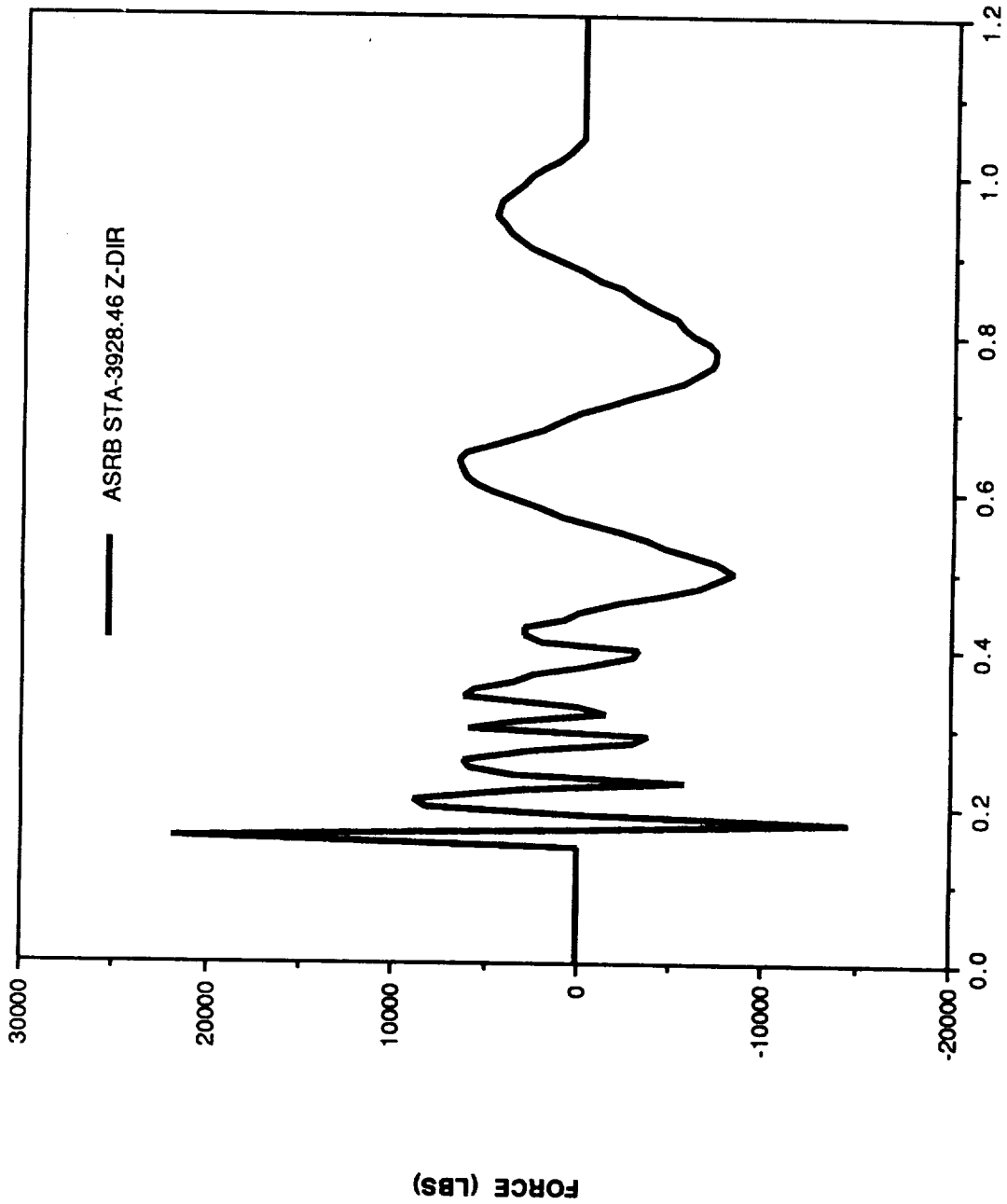

TIME (SEC)

"OVERPRESSURE FORCES NOMINAL"

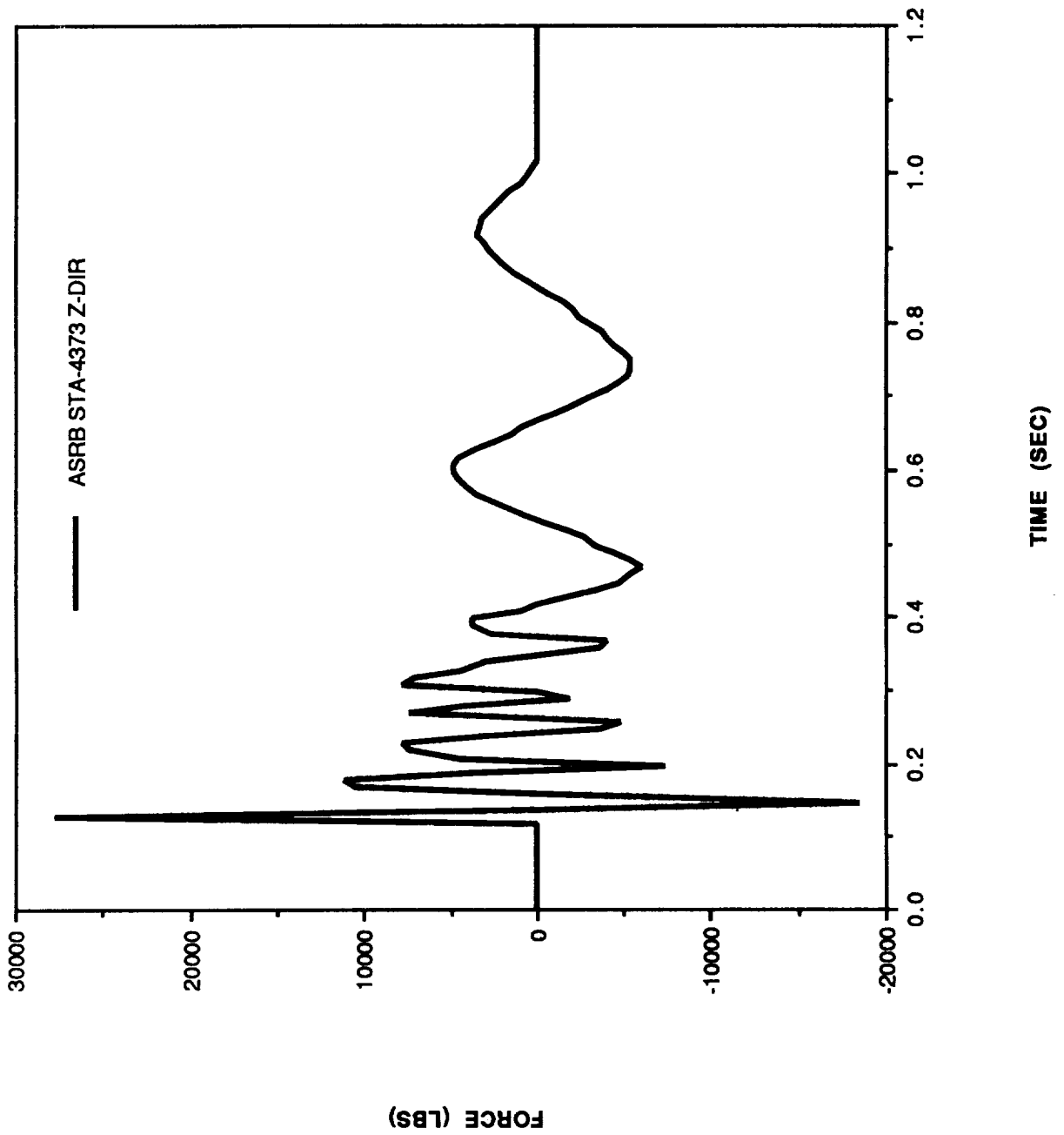

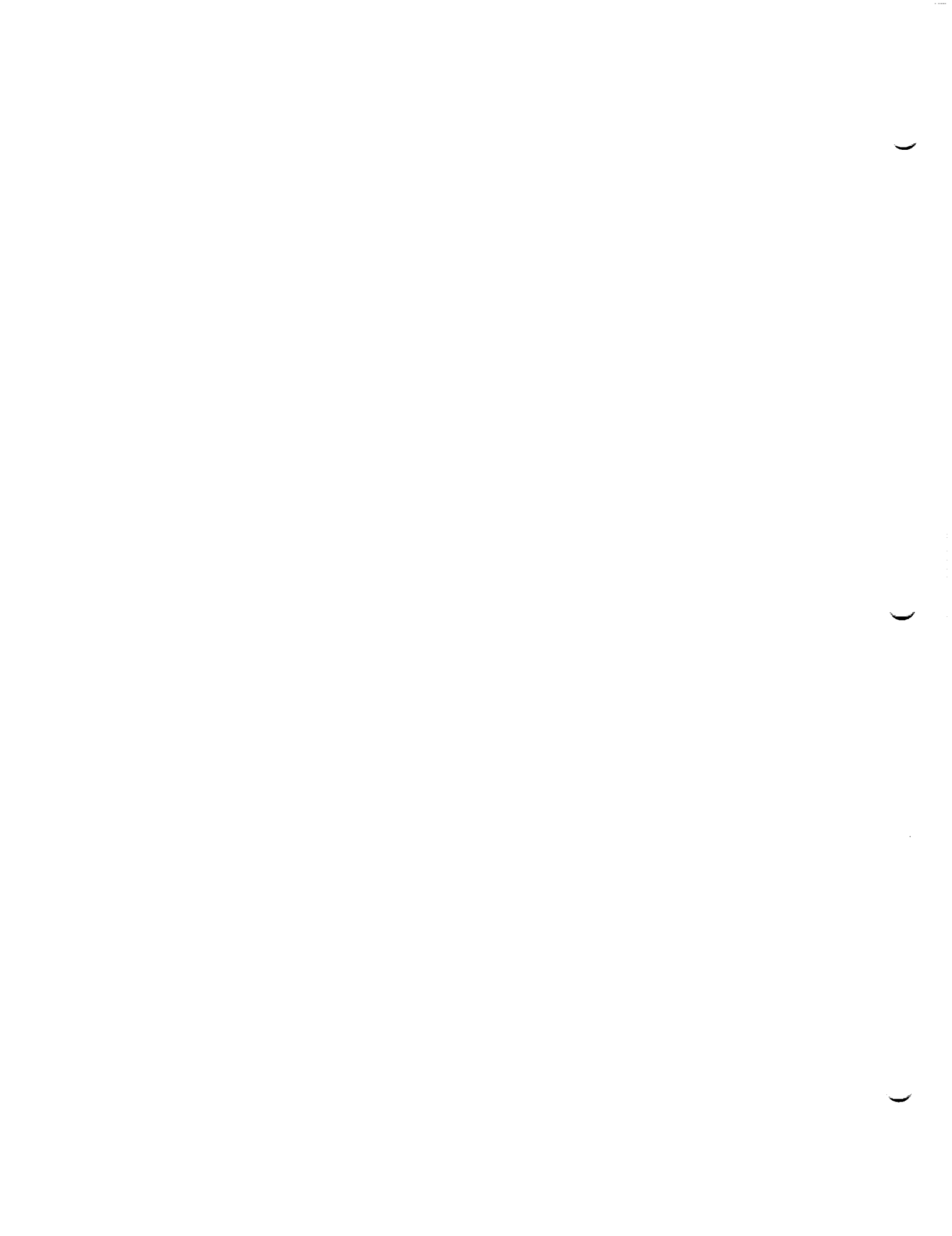

NLS 1
PRELAUNCH DATA

NLS1 WITH STME OUT BUILDUP/SHUTDOWN PAD FORCES (KIPS)

PAD NUMBER	MAXIMUM			MINIMUM		
	X-DIR	Y-DIR	Z-DIR	X-DIR	Y-DIR	Z-DIR
M1	-8.3	219.4	-20.8	-1015	-3.8	-227.1
M2	-340.1	-18.5	-88.5	-1274	-260.5	-325.8
M3	237	123.7	206.5	-696.5	-76.8	23
M4	268.3	82.9	316.5	-1008	-144.8	23.8
M5	-190	1.6	-86.6	-1021	-220.6	-224.7
M6	102.8	264.5	10	-1296	-19.4	-317.6
M7	272	66.5	212.7	-697.4	-123.9	18.1
M8	181.1	145.4	306.7	-957	-95.8	-6.5

NLS1 WITH OUT STME OUT BUILDUP/SHUTDOWN PAD FORCES (KIPS)

PAD NUMBER	MAXIMUM			MINIMUM		
	X-DIR	Y-DIR	Z-DIR	X-DIR	Y-DIR	Z-DIR
M1	-203.7	185.5	-60	-855.2	44.7	-188.9
M2	-354.8	-60.3	-115.1	-1070	-218.3	-312.5
M3	76.7	94.1	169.5	-542.8	-92	52.7
M4	16.2	36.4	302.7	-908.9	-120.2	85.2
M5	-274.1	-47.8	-87.5	-850.3	-182.9	-192
M6	-164	220.8	-48.2	-1074	41.8	-257.9
M7	65.6	27.9	197.7	-612	-99.5	56.7
M8	26.3	107.5	239.6	-730.9	-39.7	43.5

NLS1 Buildup/Shutdown Accelerations (G's)

	W/STME Out		W/O STME Out	
	Maximum	Minimum	Maximum	Minimum
Node 7 Payload 1 30K X-Dir	5.091	-3.338	2.872	-0.804
Node 7 Payload 1 30K Y-Dir	1.659	-1.639	0.1317	-0.1351
Node 7 Payload 1 30K Z-Dir	1.756	-1.763	0.0403	-0.045
Node 90 Payload 2 40K X-Dir	3.255	-2.057	2.351	0.0082
Node 90 Payload 2 40K Y-Dir	1.811	-1.799	0.0801	-0.08315
Node 90 Payload 2 40K Z-Dir	2.278	-2.264	0.02179	-0.02411
Node 12 Payload 3 30K X-Dir	3.882	-2.255	2.425	-0.25
Node 12 Payload 3 30K Y-Dir	2.306	-2.301	0.03563	-0.0373
Node 12 Payload 3 30K Z-Dir	2.66	-2.671	0.01366	-0.0153
Node 80 LO2 Slosh X-Dir	1.4923	0.4544	1.2088	0.7926
Node 81 LH2 Slosh X-Dir	2.686	2.659	1.7006	0.2734
Node 45 FPM X-Dir	5.566	-3.802	3.072	-1.01
Node 45 FPM Y-Dir	4.702	-4.674	0.1805	-0.184
Node 45 FPM Z-Dir	4.991	-5.013	0.06435	-0.06511
Node 46 CTV X-Dir	3.813	-1.559	2.112	-0.213
Node 46 CTV Y-Dir	1.341	-1.343	0.009897	-0.008607
Node 46 CTV Z-Dir	1.807	-1.819	0.009266	-0.01045

((

NLS1 Prelaunch Core Interface Loads (kips)

Location	With STME Out		Without STME Out		Allowable (Max)	Allowable (Min)
	Maximum	Minimum	Maximum	Minimum		
Fwd Attach +y	218.1	-1348	174.4	-1315	156	-1725
Fwd Attach +y	142.4	-205.8	16.83	-111.6	86	-219
Fwd Attach +y	64.26	-129.3	3.086	-68.9	204	-206
Fwd Attach -y	418.6	-1332	315.4	-1111	178	-1754
Fwd Attach -y	175	-147.4	92.32	-30.94	212	-95
Fwd Attach -y	59.36	-127.6	3.644	-68.6	207	-193
Aft Attach +y	86.38	-102	43.41	-35.07	186	-206
Aft Attach +y	79.48	-70.6	12.53	-7.795	245	-224
Aft Attach +y	91.58	-125.6	40.53	-32.02	253	-171
Aft Attach +y	12.27	-8.783	3.067	-3.877	245	-234
Aft Attach -y	103.7	-83.24	24.43	-47.53	216	-179
Aft Attach -y	84.39	-69.91	12.25	-7.619	247	-235
Aft Attach -y	120.5	-94.58	29.76	-47.92	98	-209
Aft Attach -y	11.78	-9.071	2.856	-4.587	247	-233

*upper aft attach

**lower aft attach

NLS1 GROUND WIND LOADS UNFUELED, UNPRESSURIZED, ON PAD WITH SIDE AND BROADSIDE WINDS

14-Day Wind		180-Day Wind						
X-Station (in)	Shear Forces Z-Direction (lbs)	Moment About Y-Axis (in-lbs)	Shear Forces Y-Direction (lbs)	Moment About Z-Axis (in-lbs)	Shear Forces Z-Direction (lbs)	Moment About Y-Axis (in-lbs)	Shear Forces Y-Direction (lbs)	Moment About Z-Axis (in-lbs)
1066.06	195.16	0	251.88	0	278.19	0	359.06	0
1110.6	886.25	-8692.4264	1066.81	-11218.7352	1263.61	-12390.5826	1521.06	-15992.5324
1155.1	2340.75	-48130.5514	2686.61	-58691.7802	3338.31	-68621.2276	3831.66	-83679.7024
1229.75	4699.75	-222867.5389	5252.01	-259247.2167	6705.01	-317826.0691	7492.96	-369713.1214
1304.4	8165.65	-573703.8764	8967.31	-651309.7632	11654.81	-818355.0656	12799.06	-929062.5854
1411	12343.55	-1444162.166	13437.61	-1607225.009	17626.21	-2060757.812	19188.46	-2293442.381
1518	16504.15	-2764922.016	17889.51	-3045049.279	23578.31	-3946762.282	25557.26	-4346607.601
1625	20639.15	-4530866.066	22314.11	-4959226.849	29499.31	-6469641.452	31892.86	-7081234.421
1732	23702.25	-6739255.116	25591.81	-7346836.619	33889.11	-9626067.622	36590.06	-10493770.44
1784.4	25749.15	-7981253.016	27782.11	-8687847.463	36824.61	-11401856.99	39731.06	-12411089.59
1839	28826.65	-9387156.606	31075.11	-10204750.67	41241.01	-13412480.69	44456.66	-14580405.46
1946	32837.35	-12471608.16	35366.71	-13529787.44	47001.51	-17825268.76	50620.56	-19337268.08
2050.8	36861.95	-15912962.44	39673.21	-17236218.65	52788.11	-22751027.01	56812.36	-24642302.77
2160	40851.65	-19938287.38	43942.31	-21568533.18	58530.41	-28515488.62	62956.86	-30846212.48
2264.4	43178.95	-24203199.64	46428.71	-26156110.34	61882.61	-34626063.43	66538.36	-37418908.67
2284.8	44732.55	-25084050.22	48025.21	-27103256.03	64121.91	-35888468.67	68839.56	-38776291.21
2340.68	47285.75	-27583705.11	50584.51	-29786904.76	67803.71	-39471601	72530.16	-42623045.82
2396.57	50376.35	-30226505.68	53675.11	-32614073.03	72263.31	-43261150.35	76989.76	-46676756.46
2459.17	52580.45	-33380065.19	55879.21	-35974134.91	75445.31	-47784833.56	80171.76	-51496315.44
2473.8	55913.85	-34149317.17	59212.61	-36791647.75	80260.61	-4888898.44	84987.06	-52669228.29
2569.8	61625.25	-39517046.77	64924.01	-42476058.31	88517.61	-56593617	93244.06	-60827986.05
2664.13	67247.45	-45330156.6	70542.91	-48600340.18	96654.81	-64943483.15	101376.46	-69623698.23
2758.47	74066.75	-51674281.04	75819.41	-55255358.31	106540.01	-74061897.93	109020.96	-79187553.47
2852.8	86534.75	-58660997.56	80263.81	-62407403.25	124638.01	-8411817.07	115466.76	-89471500.62
2963.42	97386.75	-68233471.61	82623.81	-71286185.91	140400.01	-97899273.74	118893.86	-102244433.6
2990.67	-143721.0031	-70887260.55	25542.90794	42541399.74	-208171.5533	-101725174	37072.30167	61870279.89
3012.52	-132770.0031	-67746956.9	27678.10794	41983287.2	-192180.5533	-9716625.57	40177.70167	61060250.1
3123.15	-114389.0031	-53058612.8	31214.90794	38921258.12	-165363.5533	-75915690.96	45327.30167	56615390.96
3233.63	-96725.00307	-40420917.09	34604.00794	35472635.09	-139602.5533	-57646325.58	50269.90167	51607630.67
3337.35	-76614.00307	-30388601.03	38462.20794	31883507.38	-110218.5533	-43166748.75	55907.10167	4639336.47
3480.57	-53606.00307	-19415945.26	42875.70794	26374949.96	-76531.55333	-27381247.55	62369.00167	38386621.37
3623.8	-32501.00307	-11737959.18	46917.10794	20233862.31	-45560.55333	-16419633.16	68299.70167	29453509.26
3747.4	-13271.00307	-7720836.704	50577.10794	14434907.77	-17271.55333	-10788348.77	73683.70167	21011666.14
3871	3365.996931	-6080542.229	53723.90794	8183577.227	7257.446668	-8653584.778	78323.10167	11904360.61
3964.5	17198.99693	-6395264.08	56325.60794	3160391.834	27695.44667	-9322156.041	82166.90167	4581150.603
4054	-43561.91927	-7934575.394	-8127.331459	-1880750.077	-64773.66978	-11810898.52	-12084.68992	-2772787.096
4118.65	-38458.31927	-5118297.601	-7173.101459	-1355318.098	-57210.76978	-7623280.767	-10670.68992	-1991511.893
4122.65	-30001.41927	-4964464.342	-5595.001459	-1326625.692	-44660.76978	-7394437.688	-8328.789917	-1948829.133
4233.27	-16365.41927	-1645707.835	-3051.801459	-707706.6309	-24392.76978	-2454063.335	-4548.589917	-1027498.392
4309.4	-5423.419275	-399808.8053	-1011.001459	-475372.9859	-8090.769776	-597041.7722	-1508.189917	-681214.2421
4385.5	-3.71927485	12913.06214	-0.20145911	-398435.7748	-5.3697761	18665.80778	-0.28991746	-566440.9894

Fwd Attach

Aft Attach

**NLS1 CORE PRELAUNCH
STATIC Y-DIR SHEAR LOADS VS X-STATION**

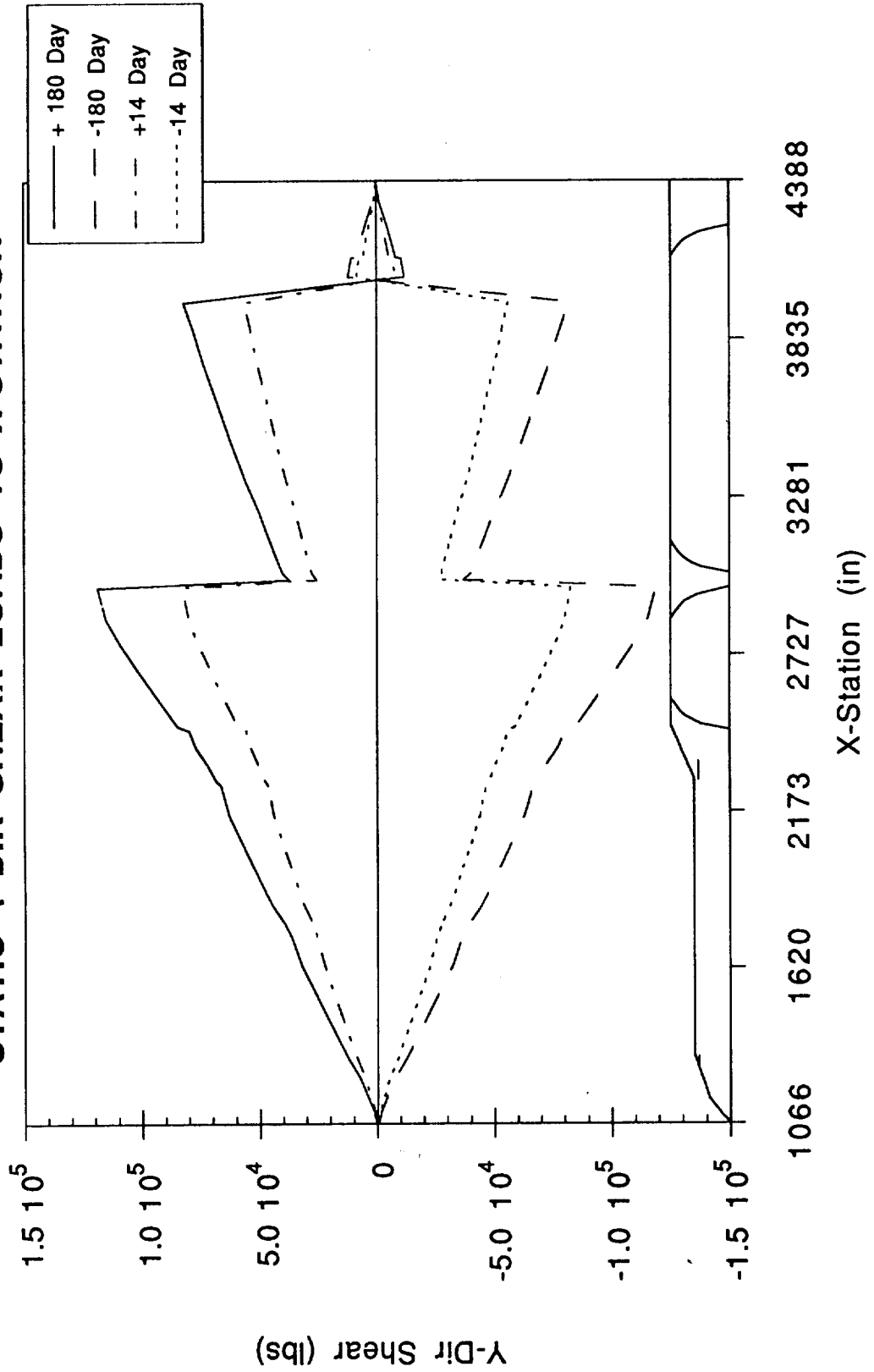

NLS1 CORE PRELAUNCH STATIC Z-DIR SHEAR LOADS VS X-STATION

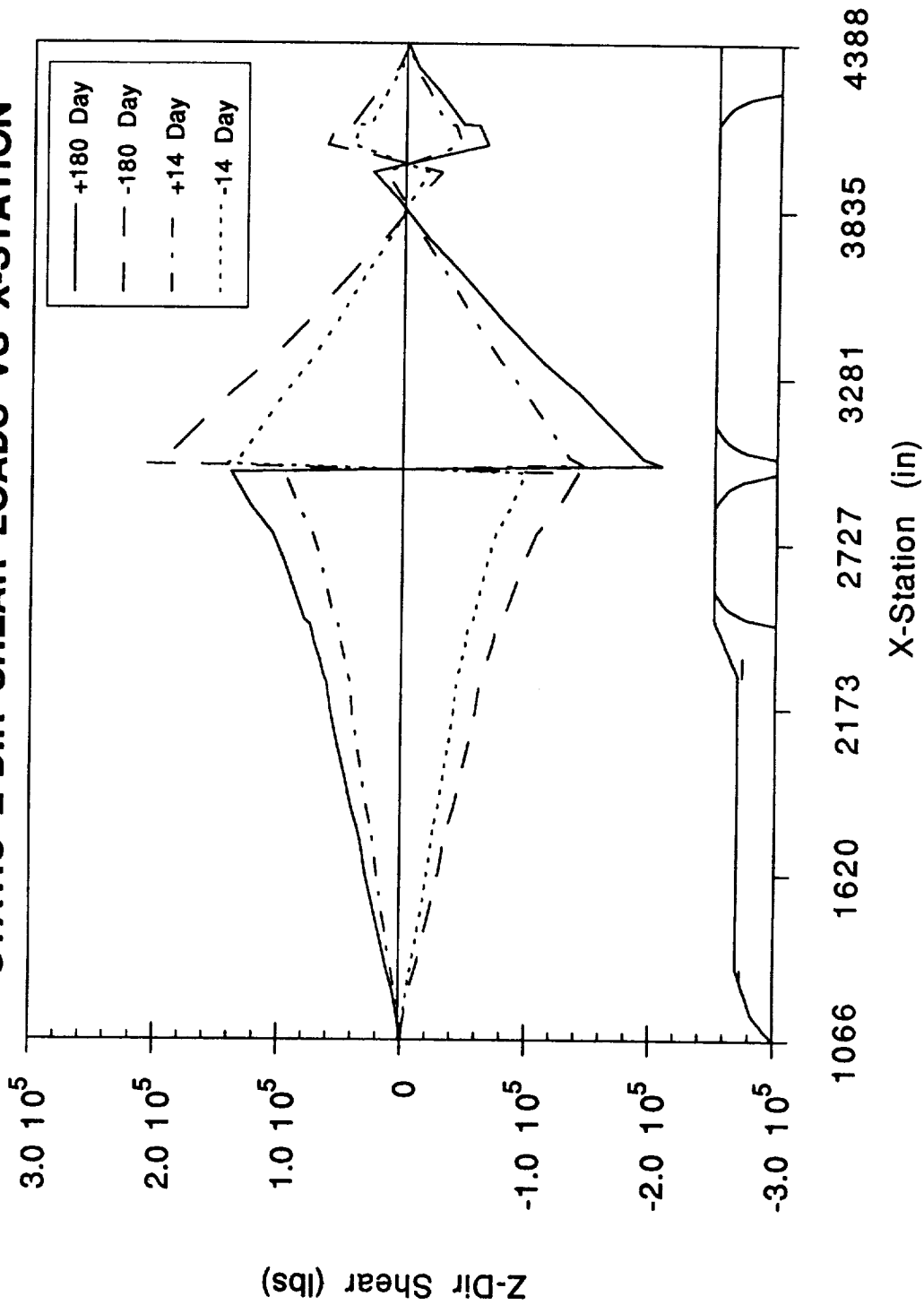

(

(

(

NLS1 CORE PRELAUNCH STATIC Y-DIR MOMENT VS X-STATION

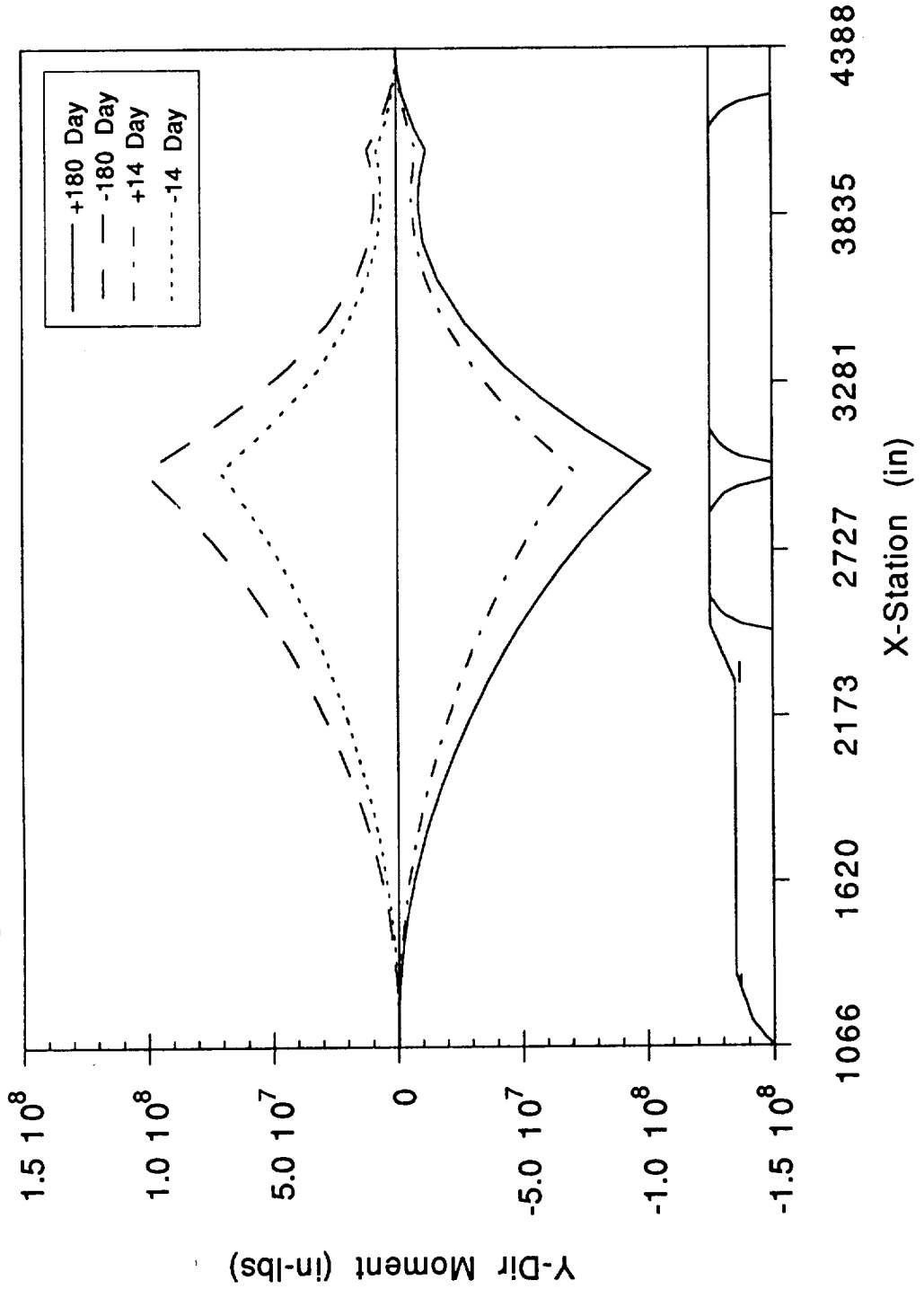

**NLS1 CORE PRELAUNCH
STATIC Z-DIR MOMENT VS X-STATION**

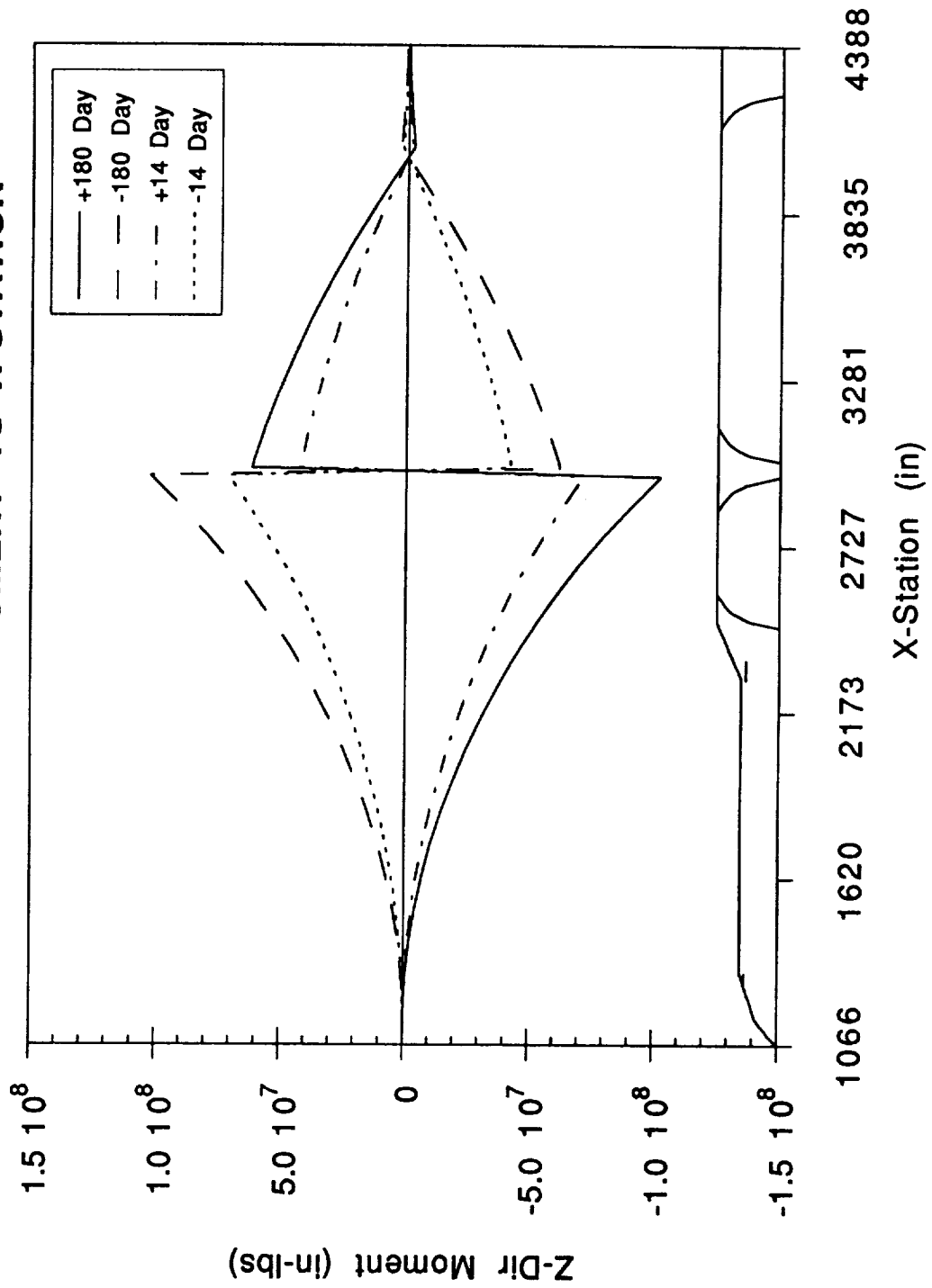

**NLS1 COMPOSITE SHEAR BODY LOADS W/STME OUT (LBS)
BUILD-UP AND SHUT-DOWN**

X-Station (in)	X-Dir.		Y-Dir.		Z-Dir.	
	Maximum	Minimum	Maximum	Minimum	Maximum	Minimum
1066.06	118.4	-73.7	384.8	-231.7	343.8	-235.7
1110.6	1762	-1097	3547	-2999	3422	-3069
1155.1	4757	-2957	8712	-7248	8534	-7452
1229.75	10560	-6535	16260	-13080	16200	-13540
1304.4	40380	-24810	41570	-35830	43080	-37510
1411	50010	-30550	47040	-38370	49020	-40660
1518	219500	-128700	65480	-54420	78930	-67650
1625	227300	-132500	69080	-55130	81670	-67660
1732	233700	-134900	69860	-53800	81220	-65200
1784.4	371700	-173600	109200	-92230	116700	-99170
1839	376900	-174500	110600	-93660	120400	-100900
1946	381300	-174100	111700	-92640	122500	-100300
2050.8	455500	-144100	112700	-90880	133700	-134500
2160	460900	-142100	116400	-91770	133700	-134500
2264.4	465800	-139700	119200	-91750	133000	-133700
2284.8	548400	-138300	114000	-83810	139100	-123400
2340.68	551400	-138800	115300	-83460	141400	-122900
2396.57	554000	-139200	116700	-82900	143500	-122400
2459.17	676800	-142100	238300	-202100	311400	-273600
2473.8	801400	-154900	405500	-366500	521900	-480700
2569.8	912900	-144600	402000	-358600	460400	-415000
2664.13	1005000	-123900	284200	-280500	321300	-298500
2758.47	1059000	-103700	299800	-297500	427100	-374700
2852.8	1070000	-68050	290500	-237000	314000	-312800
2963.42	2435000	880900	331000	-276700	262100	-262400
2990.67	1949000	-685700	245600	-239200	263300	-334500
3012.52	1955000	-673400	232100	-224900	249800	-317700
3123.15	1954000	-659500	202000	-193800	205600	-269300
3233.63	1955000	-649200	175400	-166300	175900	-233300
3337.35	1960000	-638000	167600	-160700	178000	-228600
3480.57	1967000	-625900	163000	-156200	170300	-214600
3623.8	1973000	-613000	147300	-141100	179500	-216600
3747.4	1978000	-599500	170400	-158700	175800	-206300
3871	1984000	-585300	166500	-155000	204900	-229300
3964.5	1990000	-570800	156100	-152400	222000	-241200
4054	1996000	-555500	246700	-251400	230200	-256200
4118.65	2003000	-538800	218400	-222200	209400	-232400
4122.65	2009000	-522300	249600	-252400	229800	-248900
4233.27	2197000	-210200	246500	-247800	231600	-244700
4309.4	2224000	-131100	202700	-203000	191900	-199100
4385.5	6980	-21410	12490	-12430	1999	-2142

NLS1 COMPOSITE MOMENT BODY LOADS W/STME OUT (IN-LBS)

BUILD-UP AND SHUT-DOWN

X-Station (in)	X-Dir.		Y-Dir.		Z-Dir.	
	Maximum	Minimum	Maximum	Minimum	Maximum	Minimum
1066.06	44860	-44780	0	0	0	0
1110.6	61030	-60800	15310	-10500	17140	-10320
1155.1	73650	-73260	167600	-147100	175000	-143800
1229.75	82830	-82260	804700	-703400	825300	-684800
1304.4	140400	-135300	2608000	-2297000	2602000	-2215000
1411	191500	-184200	7196000	-6212000	7034000	-5999000
1518	563200	-540200	23960000	-23410000	23380000	-22410000
1625	608400	-583300	28960000	-25840000	26810000	-23690000
1732	649400	-622400	35040000	-30410000	30730000	-26120000
1784.4	943700	-901500	45160000	-39670000	35850000	-30380000
1839	980200	-936000	44550000	-38140000	36040000	-29630000
1946	1011000	-965200	43520000	-35060000	36650000	-28480000
2050.8	1214000	-1198000	44810000	-39110000	39470000	-30190000
2160	1250000	-1234000	40880000	-41450000	43010000	-32060000
2264.4	1286000	-1269000	50290000	-50150000	50790000	-36990000
2284.8	1674000	-1643000	62130000	-62730000	59080000	-43500000
2340.68	1741000	-1707000	66500000	-67080000	65350000	-48090000
2396.57	1807000	-1772000	71630000	-71540000	71730000	-52690000
2459.17	2001000	-1958000	80300000	-76860000	78970000	-57810000
2473.8	2128000	-2081000	81090000	-76290000	79070000	-57390000
2569.8	2252000	-2201000	80380000	-66040000	70960000	-45540000
2664.13	2372000	-2318000	92760000	-80540000	87750000	-58080000
2758.47	2489000	-2431000	113800000	-78520000	105300000	-71060000
2852.8	2774000	-2708000	111800000	-70830000	103500000	-64320000
2963.42	3047000	-2975000	111000000	-69550000	103600000	-62180000
2990.67	2752000	-2712000	108600000	-67980000	85750000	-108100000
3012.52	2940000	-2954000	103900000	-67120000	85440000	-107500000
3123.15	3139000	-3183000	79130000	-63680000	83720000	-104200000
3233.63	3271000	-3296000	74670000	-70690000	82050000	-100900000
3337.35	3394000	-3403000	74720000	-74520000	80710000	-98830000
3480.57	3505000	-3500000	78260000	-74710000	84830000	-98340000
3623.8	3604000	-3587000	87560000	-84330000	87290000	-99300000
3747.4	3692000	-3665000	93310000	-88290000	88590000	-99040000
3871	3769000	-3734000	95360000	-92960000	89530000	-97740000
3964.5	3837000	-3795000	95950000	-96750000	95520000	-100700000
4054	3649000	-3448000	103900000	-106300000	107500000	-107600000
4118.65	3470000	-3280000	101900000	-104100000	100600000	-101700000
4122.65	3290000	-3111000	101600000	-103800000	100200000	-101300000
4233.27	3068000	-2903000	90180000	-91770000	89460000	-90890000
4309.4	3011000	-2850000	80880000	-81800000	83930000	-85290000
4385.5	217000	-219900	1438000	-1366000	11310000	-11760000

NLS1 COMPOSITE LINE BODY LOADS W/STME OUT BUILD-UP AND SHUT-DOWN

X-Station (in)	NX+ (lbs/in)		NX- (lbs/in)		PEQ+ (lbs)		PEQ- (lbs)	
	Maximum	Minimum	Maximum	Minimum	Maximum	Minimum	Maximum	Minimum
1066.06	0	0	0	0	0	0	0	0
1110.6	9.68	-3.318	9.68	-3.318	9.68	-3.318	2129	-729.6
1155.1	15.23	-5.231	15.23	-5.231	15.23	-5.231	5741	-1972
1229.75	25.25	-8.747	25.25	-8.747	25.25	-8.747	12690	-4397
1304.4	98.3	-23.17	98.3	-23.17	98.3	-23.17	37410	-24870
1411	94.62	-33.52	94.62	-33.52	94.62	-33.52	59450	-21060
1518	885.7	-63.06	885.7	-63.06	885.7	-63.06	171700	-273300
1625	414.6	-157.7	414.6	-157.7	414.6	-157.7	260500	-99070
1732	423.4	-162.8	423.4	-162.8	423.4	-162.8	266000	-102300
1784.4	1054	-168	1054	-168	1054	-168	269400	-296700
1839	596.5	-282.2	596.5	-282.2	596.5	-282.2	374800	-177300
1946	601.1	-283.8	601.1	-283.8	601.1	-283.8	377700	-178300
2050.8	885.7	-143.4	885.7	-143.4	885.7	-143.4	380700	-313100
2160	690.9	-273.3	690.9	-273.3	690.9	-273.3	434100	-171700
2264.4	699.3	-268.7	699.3	-268.7	699.3	-268.7	439400	-168800
2284.8	1492	-112.2	1492	-112.2	1492	-112.2	376500	-973600
2340.68	691.7	-197.6	691.7	-197.6	691.7	-197.6	538300	-153800
2396.57	609.8	-172.8	609.8	-172.8	609.8	-172.8	541600	-153400
2459.17	699.1	-111.2	699.1	-111.2	699.1	-111.2	706800	-112400
2473.8	837.8	-82.21	837.8	-82.21	837.8	-82.21	871200	-85480
2569.8	940.4	-76.17	940.4	-76.17	940.4	-76.17	977800	-79210
2664.13	976.4	-107.8	976.4	-107.8	976.4	-107.8	1015000	-112100
2758.47	960.3	-154.3	960.3	-154.3	960.3	-154.3	998600	-160500
2852.8	930.2	-159.8	930.2	-159.8	930.2	-159.8	967200	-166200
2963.42	2278	775.9	2278	775.9	2278	775.9	2369000	806800
2990.67	3056	-490	3056	-490	3056	-490	1871000	-1471000
3012.52	1831	-647.9	1831	-647.9	1831	-647.9	1904000	-673700
3123.15	1861	-634.1	1861	-634.1	1861	-634.1	1935000	-659400
3233.63	1893	-623.7	1893	-623.7	1893	-623.7	1968000	-648600
3337.35	1949	-612.4	1949	-612.4	1949	-612.4	2027000	-636800
3480.57	2003	-600.3	2003	-600.3	2003	-600.3	2083000	-624300
3623.8	2046	-587.6	2046	-587.6	2046	-587.6	2127000	-611000
3747.4	2073	-574.4	2073	-574.4	2073	-574.4	2155000	-597300
3871	2077	-560.8	2077	-560.8	2077	-560.8	2160000	-583200
3964.5	2058	-547.1	2058	-547.1	2058	-547.1	2140000	-569000
4054	2014	-533	2014	-533	2014	-533	2094000	-554200
4118.65	1944	-517.8	1944	-517.8	1944	-517.8	2022000	-538400
4122.65	1873	-502.7	1873	-502.7	1873	-502.7	1948000	-522800
4233.27	1947	-209.7	1947	-209.7	1947	-209.7	2024000	-218100
4309.4	1381	-141.6	1381	-141.6	1381	-141.6	1436000	-147200
4385.5	400.1	0.0007267	-0.0006737	-400.1	-0.0006737	-400.1	-0.7006	-416000

NLS1 CORE BUILDUP/SHUTDOWN W/STME OUT COMPOSITE AXIAL SHEAR LOADS VS X-STATION

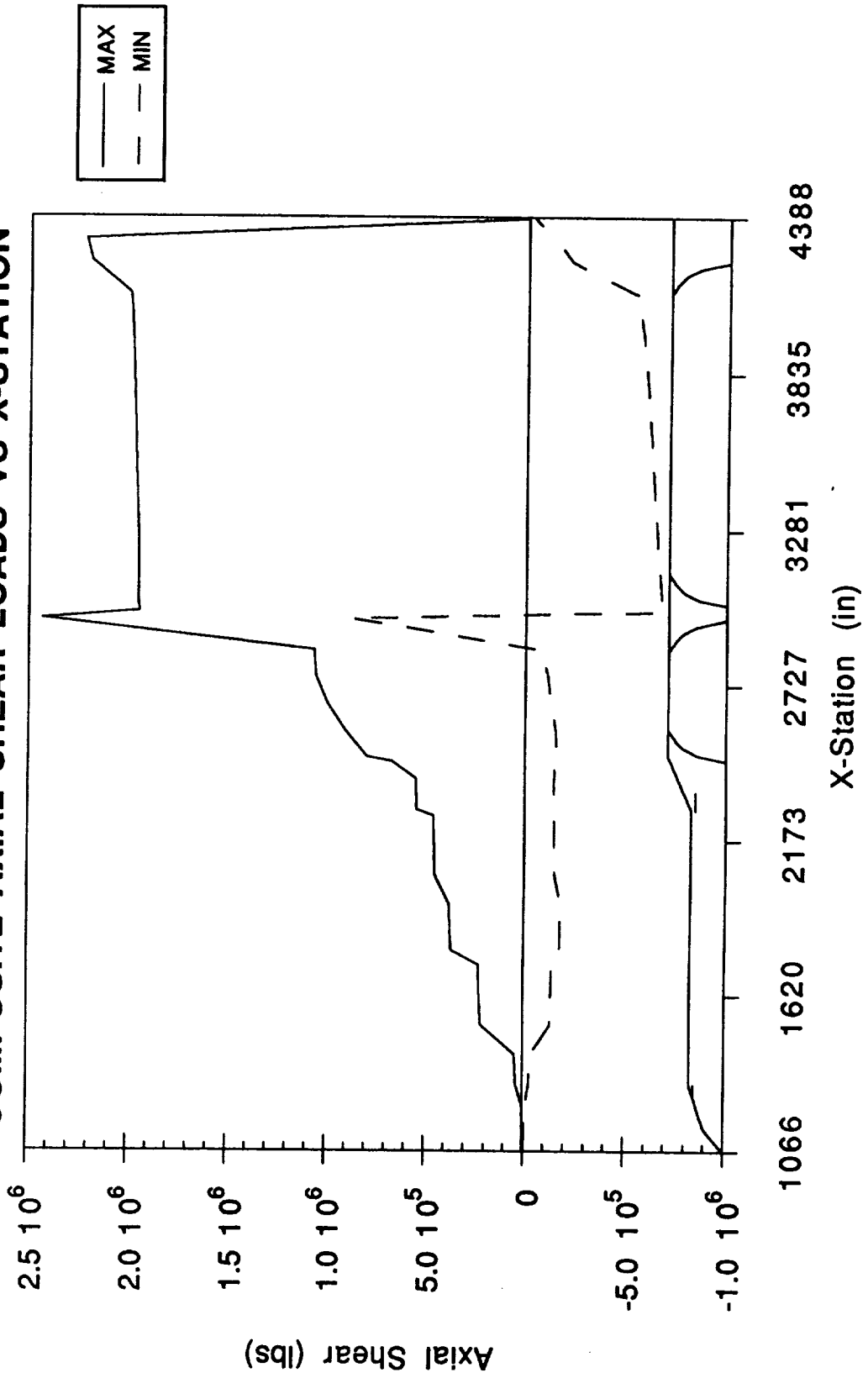

**NLS1 CORE BUILDUP/SHUTDOWN W/STME OUT
COMPOSITE Y-DIR SHEAR LOADS VS X-STATION**

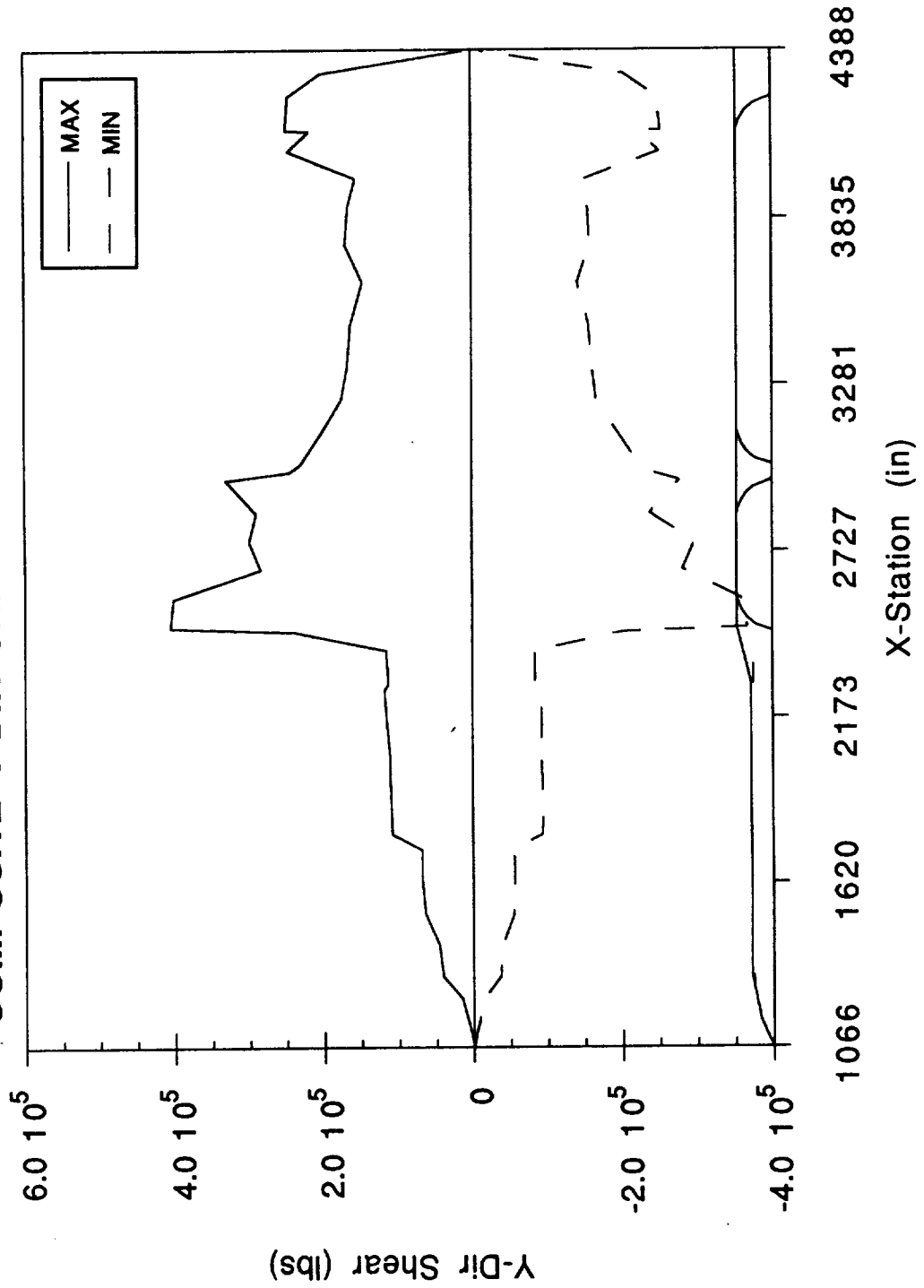

NLS1 CORE BUILDUP/SHUTDOWN W/STME OUT COMPOSITE Z-DIR SHEAR LOADS VS X-STATION

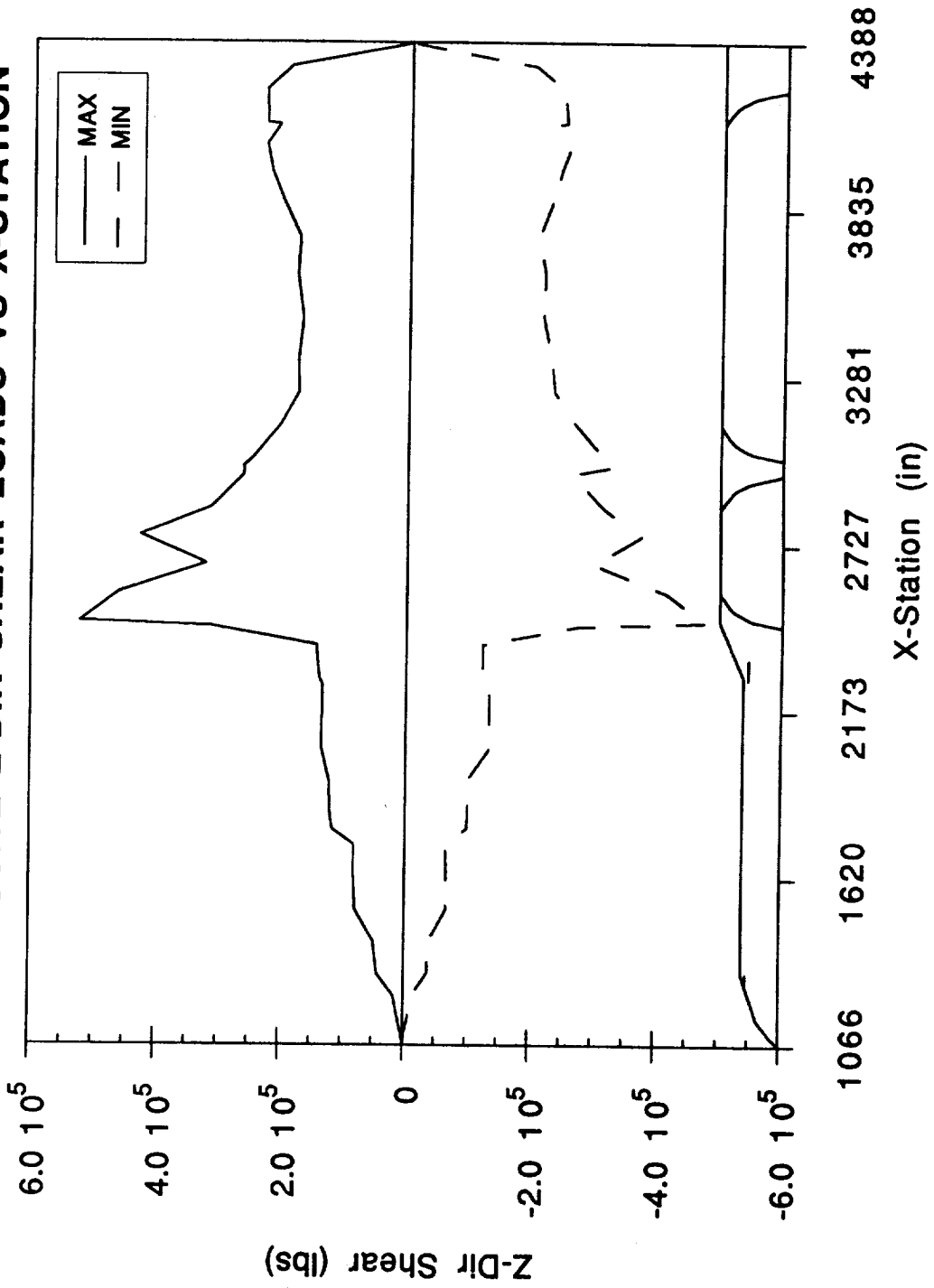

(((

**NLS1 CORE BUILDUP/SHUTDOWN W/STME OUT
COMPOSITE X-DIR TORSION VS X-STATION**

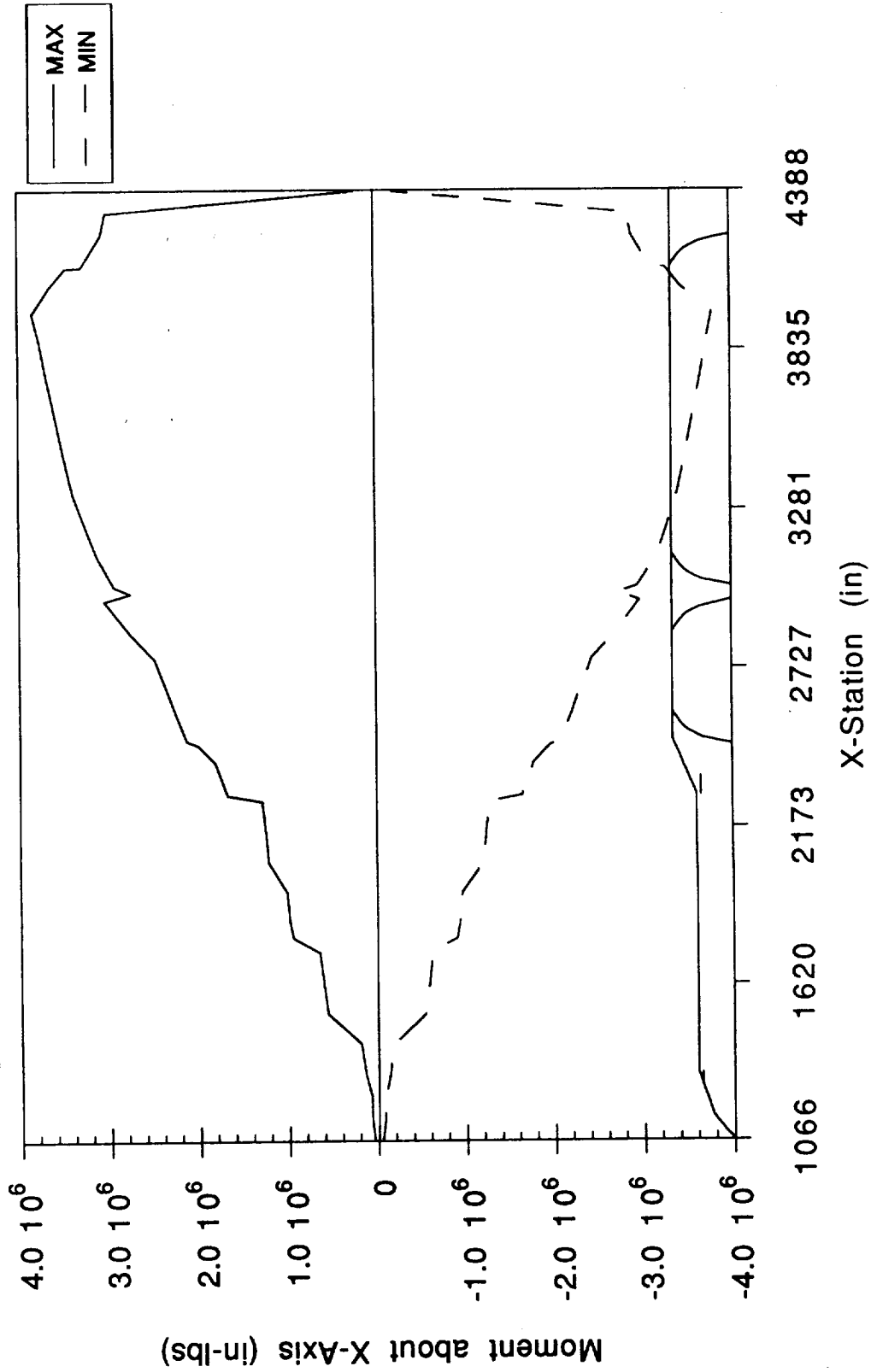

NLS1 CORE BUILDUP/SHUTDOWN W/STME OUT COMPOSITE Y-DIR MOMENT VS X-STATION

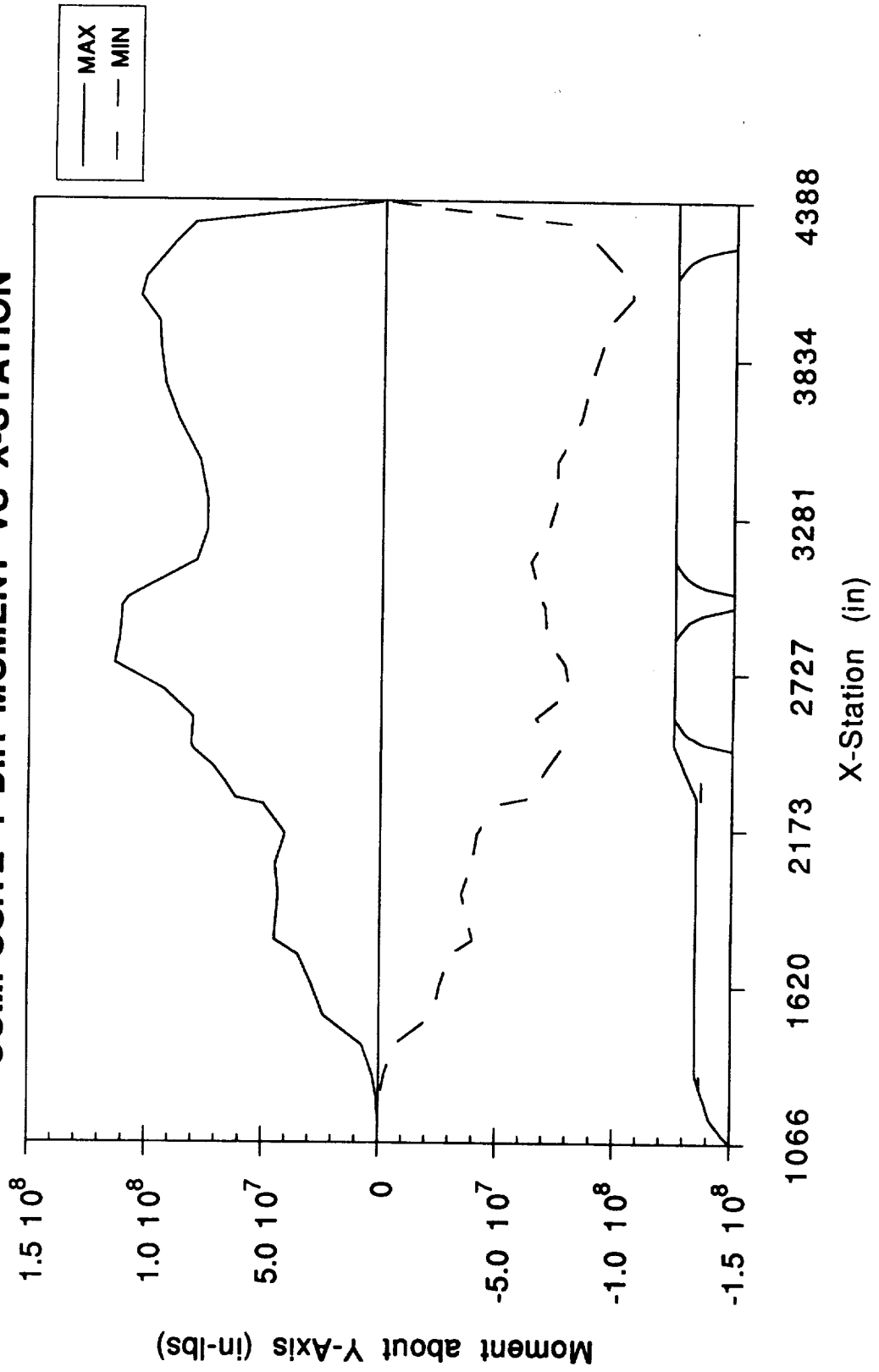

(((

**NLS1 CORE BUILDUP/SHUTDOWN W/STME OUT
COMPOSITE Z-DIR MOMENT VS X-STATION**

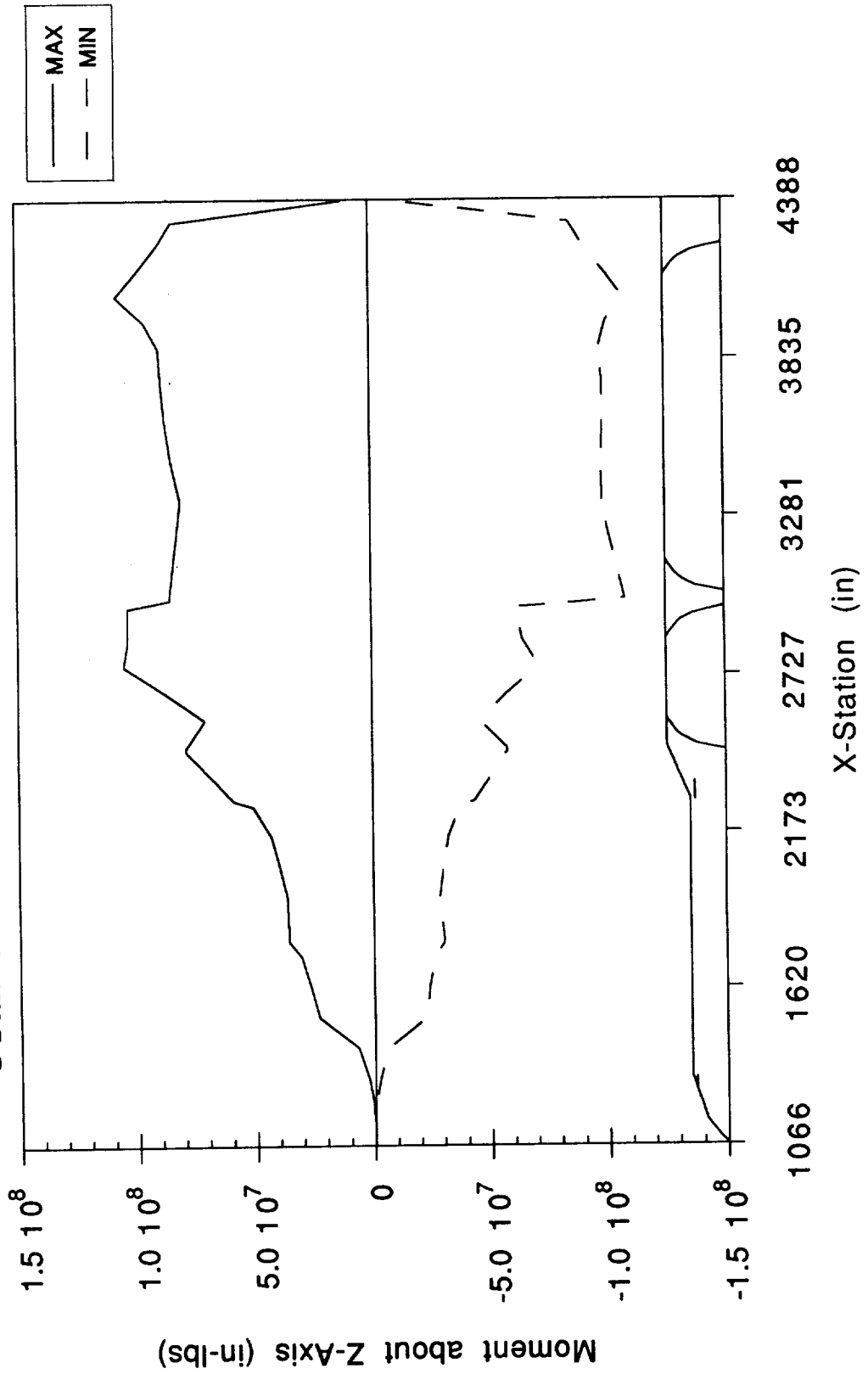

**NLS1 CORE BUILDUP/SHUTDOWN W/STME OUT
COMPOSITE NX+ LOADS VS X-STATION**

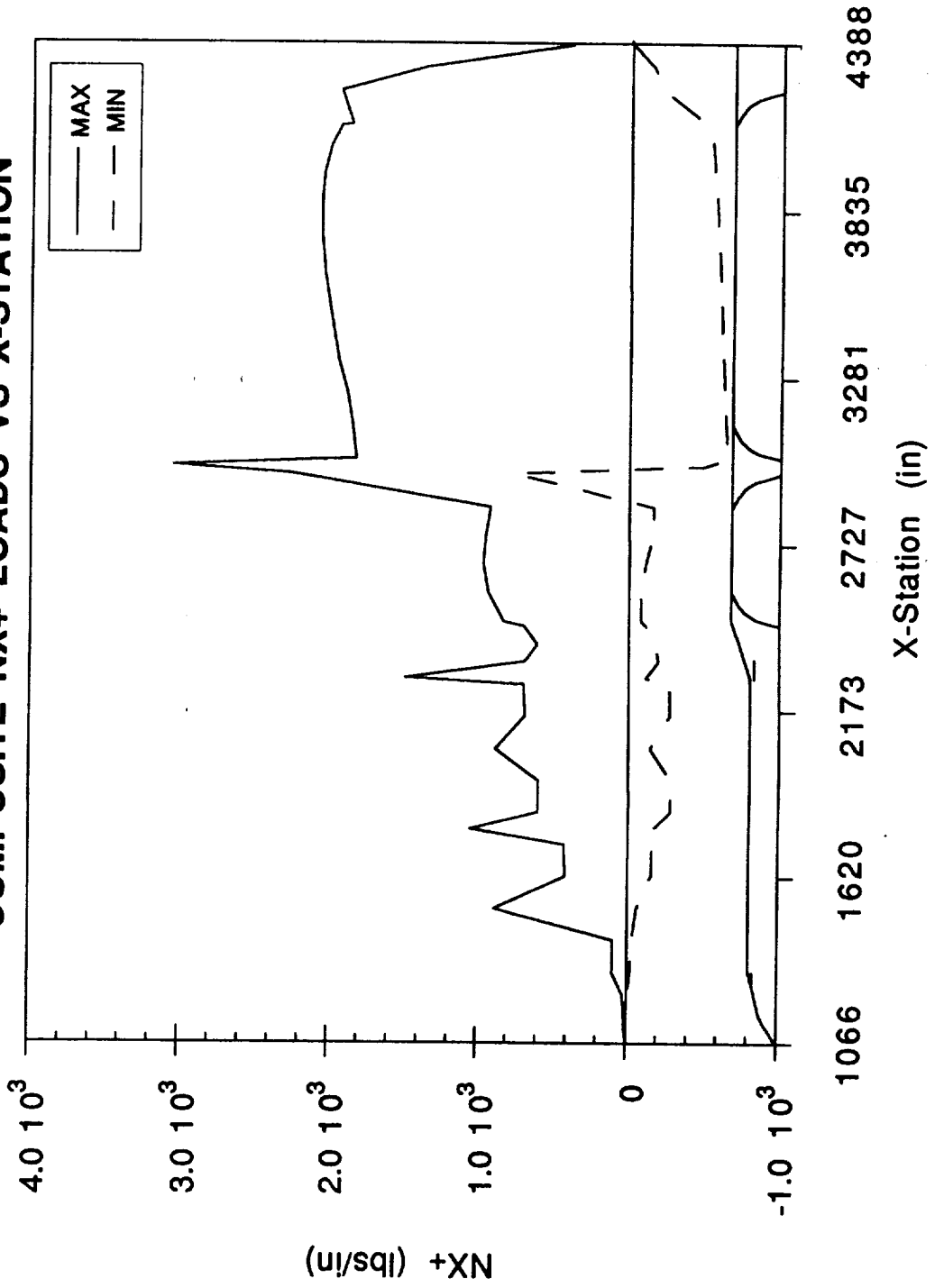

**NLS1 CORE BUILDUP/SHUTDOWN W/STME OUT
COMPOSITE NX- LOADS VS X-STATION**

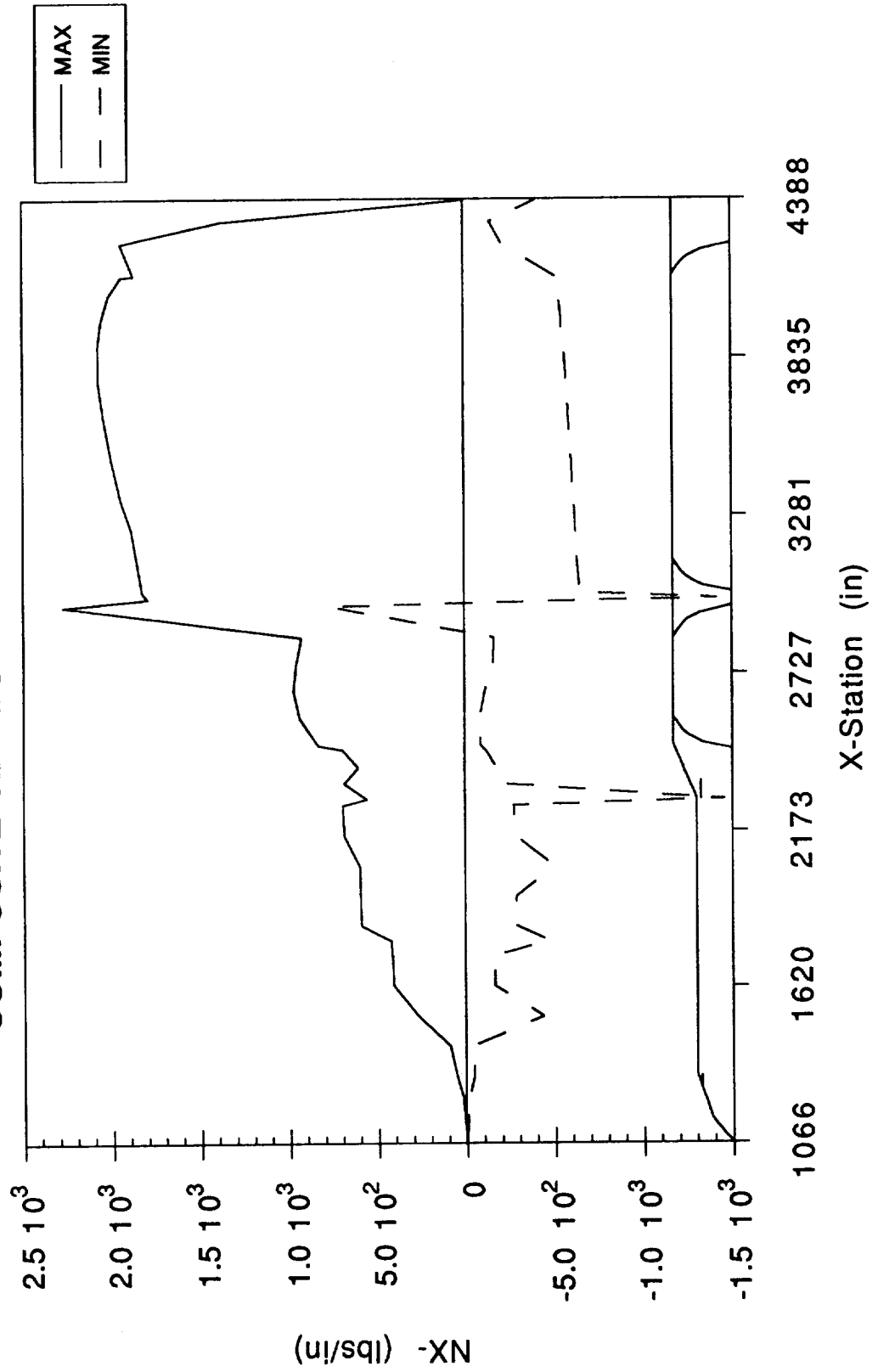

NLS1 COMPOSITE SHEAR BODY LOADS W/O STME OUT (LBS)

BUILD-UP AND SHUT-DOWN

X-Station (in)	X-Dir.		Y-Dir.		Z-Dir.	
	Maximum	Minimum	Maximum	Minimum	Maximum	Minimum
1066.06	66.22	-17.1	24.25	-4.45	19.17	-1.682
1110.6	985.6	-254.5	335.4	-63.76	264.4	-23.76
1155.1	2660	-686.2	857.6	-167.6	674.6	-61.78
1229.75	5902	-1515	1734	-356.2	1357	-128.8
1304.4	22540	-5748	5761	-1278	4479	-448.9
1411	27890	-7071	6733	-1544	5202	-535.4
1518	121700	-29570	19280	-5724	14170	-1802
1625	126000	-30420	19750	-5916	14500	-1856
1732	129400	-30880	20130	-6072	14790	-1897
1784.4	201400	-38020	28810	-9418	21650	-2777
1839	204100	-38110	29170	-9540	21950	-2808
1946	206200	-37790	29520	-9629	22250	-2828
2050.8	235200	-32780	35330	-10750	27010	-3004
2160	236800	-32770	35580	-10780	27190	-3006
2264.4	238400	-32310	35760	-10800	27320	-3004
2284.8	274200	-28460	37860	-10890	28770	-2955
2340.68	276300	-28020	37940	-10900	28830	-2953
2396.57	278200	-27390	38000	-10890	28870	-2950
2459.17	373100	14230	44290	-9322	35620	-2877
2473.8	470800	52360	49820	-8039	42630	-3171
2569.8	548200	88450	51250	-6329	47650	-3658
2664.13	609200	122300	51200	-4695	50480	-3817
2758.47	662500	168500	54870	-6058	50970	-3681
2852.8	717800	243600	62670	-11960	53300	-3096
2963.42	1907000	1243000	74330	-18890	64100	-3491
2990.67	1833000	-509700	24210	-7031	3378	-73310
3012.52	1859000	-496600	25920	-7868	3246	-70980
3123.15	1916000	-477300	28280	-8718	3068	-66390
3233.63	1968000	-463300	30860	-9423	2879	-60480
3337.35	2027000	-453100	33800	-10050	2661	-53400
3480.57	2083000	-443400	36910	-10480	2433	-45780
3623.8	2127000	-433500	39800	-10670	2479	-38680
3747.4	2155000	-423700	42180	-10620	2513	-32320
3871	2160000	-414000	43870	-10320	2532	-26790
3964.5	2140000	-404400	44970	-9814	2993	-22590
4054	2094000	-394800	19060	-14960	7906	-21580
4118.65	2022000	-384700	19010	-12910	9890	-17670
4122.65	1948000	-374700	18900	-10860	11950	-13790
4233.27	2024000	-119400	17000	-8764	11950	-10480
4309.4	1436000	-80520	12860	-6047	9816	-6822
4385.5	0.0493	0.004476	1.201	-0.6032	1.053	-0.3609

NLS1 COMPOSITE MOMENT BODY LOADS W/O STME OUT (IN-LBS)

BUILD-UP AND SHUT-DOWN

X-Station (in)	X-Dir.		Y-Dir.		Y-Dir.		Z-Dir.	
	Maximum	Minimum	Maximum	Minimum	Maximum	Minimum	Maximum	Minimum
1066.06	352.6	-367	0.01801	-0.0004282	0.06722	-0.001604		
1110.6	700.2	-671.6	854	-74.78	1080	-198.2		
1155.1	1055	-972.6	12620	-1132	16010	-3035		
1229.75	1422	-1274	62980	-5743	80020	-15550		
1304.4	3001	-2631	234000	-22230	298200	-61580		
1411	4260	-3723	711400	-70000	912200	-197800		
1518	13640	-11910	2030000	-193500	2593000	-497300		
1625	14850	-13000	3540000	-382800	4656000	-1110000		
1732	16030	-14080	5087000	-580300	6769000	-1743000		
1784.4	24730	-22370	5763000	-738000	7851000	-2186000		
1839	25870	-23510	6945000	-874300	9423000	-2700000		
1946	26970	-24670	9294000	-1158000	12540000	-3721000		
2050.8	35330	-33440	11900000	-1479000	15830000	-4830000		
2160	36470	-34580	14830000	-1806000	19690000	-6003000		
2264.4	37590	-35680	17650000	-2118000	23400000	-7129000		
2284.8	49590	-47470	19040000	-2214000	25270000	-7606000		
2340.68	51660	-49500	20620000	-2379000	27380000	-8215000		
2396.57	53730	-51510	22210000	-2544000	29500000	-8824000		
2459.17	59780	-57320	24000000	-2728000	31880000	-9506000		
2473.8	63760	-61140	24500000	-2764000	32530000	-9641000		
2569.8	67720	-64860	28370000	-2957000	37290000	-10360000		
2664.13	71650	-68490	32540000	-3124000	42010000	-10760000		
2758.47	75560	-72020	36920000	-3286000	46470000	-10760000		
2852.8	85310	-80650	41520000	-3435000	50530000	-10280000		
2963.42	94980	-89080	47200000	-3578000	54860000	-9232000		
2990.67	412600	-415600	48900000	-3607000	12540000	-39230000		
3012.52	406300	-412300	47380000	-3547000	12400000	-38700000		
3123.15	400000	-408900	40050000	-3252000	11550000	-35840000		
3233.63	396800	-407400	33260000	-2980000	10600000	-32950000		
3337.35	393500	-405900	27510000	-2745000	9640000	-30300000		
3480.57	390100	-404700	20560000	-2452000	8227000	-26280000		
3623.8	386700	-403600	14710000	-2195000	6758000	-21860000		
3747.4	383300	-402300	10590000	-2014000	5474000	-17690000		
3871	379900	-400800	7319000	-1889000	4208000	-13250000		
3964.5	376500	-398800	5492000	-2142000	3290000	-9702000		
4054	92870	-90880	4223000	-4120000	3392000	-6151000		
4118.65	86120	-84330	2829000	-3618000	2425000	-4919000		
4122.65	79380	-77790	2758000	-3578000	2374000	-4843000		
4233.27	72420	-71010	1234000	-2257000	1172000	-2752000		
4309.4	70790	-69410	436200	-1347000	505100	-1458000		
4385.5	0.0004588	-3.942	2140	-907.5	3067	-2000		

NLS1 COMPOSITE LINE BODY LOADS W/O STME OUT

BUILD-UP AND SHUT-DOWN

X-Station (in)	NX+ (lbs/in)		NX- (lbs/in)		PEQ+ (lbs)		PEQ- (lbs)	
	Maximum	Minimum	Maximum	Minimum	Maximum	Minimum	Maximum	Minimum
1066.06	0	0	0	0	0	0	0	0
1110.6	4.482	-1.157	4.482	-1.157	4.482	-1.157	985.6	-254.5
1155.1	7.057	-1.82	7.057	-1.82	7.057	-1.82	2660	-686.2
1229.75	11.74	-3.015	11.74	-3.015	11.74	-3.015	5902	-1515
1304.4	38.08	-9.131	35.83	-11.31	35.83	-11.31	22510	-7103
1411	44.39	-11.25	44.39	-11.25	44.39	-11.25	27890	-7071
1518	220	-46.97	193.5	-73.23	193.5	-73.23	121600	-46010
1625	200.5	-48.42	200.5	-48.42	200.5	-48.42	126000	-30420
1732	205.9	-49.15	205.9	-49.15	205.9	-49.15	129400	-30880
1784.4	325.1	-60.45	320.5	-65.12	320.5	-65.12	201300	-40910
1839	324.8	-60.66	324.8	-60.66	324.8	-60.66	204100	-38110
1946	328.2	-60.14	328.2	-60.14	328.2	-60.14	206200	-37790
2050.8	381.8	-52	374.3	-59.52	374.3	-59.52	235200	-37400
2160	376.9	-52.15	376.9	-52.15	376.9	-52.15	236800	-32770
2264.4	379.4	-51.42	379.4	-51.42	379.4	-51.42	238400	-32310
2284.8	434.7	-42.32	410.1	-67.02	410.1	-67.02	274100	-44790
2340.68	355	-36	355	-36	355	-36	276300	-28020
2396.57	313.2	-30.84	313.2	-30.84	313.2	-30.84	278200	-27390
2459.17	369	14.08	369	14.08	369	14.08	373100	14230
2473.8	452.7	50.35	452.7	50.35	452.7	50.35	470800	52360
2569.8	527.2	85.06	527.2	85.06	527.2	85.06	548200	88450
2664.13	585.8	117.6	585.8	117.6	585.8	117.6	609200	122300
2758.47	637.1	162	637.1	162	637.1	162	662500	168500
2852.8	690.3	234.2	690.3	234.2	690.3	234.2	717800	243600
2963.42	1834	1195	1834	1195	1834	1195	1907000	1243000
2990.67	2487	-490	1746	-1364	1746	-1364	1815000	-1418000
3012.52	1788	-477.6	1788	-477.6	1788	-477.6	1859000	-496600
3123.15	1843	-459	1843	-459	1843	-459	1916000	-477300
3233.63	1893	-445.5	1893	-445.5	1893	-445.5	1968000	-463300
3337.35	1949	-435.7	1949	-435.7	1949	-435.7	2027000	-453100
3480.57	2003	-426.4	2003	-426.4	2003	-426.4	2083000	-443400
3623.8	2046	-416.9	2046	-416.9	2046	-416.9	2127000	-433500
3747.4	2073	-407.5	2073	-407.5	2073	-407.5	2155000	-423700
3871	2077	-398.1	2077	-398.1	2077	-398.1	2160000	-414000
3964.5	2058	-388.9	2058	-388.9	2058	-388.9	2140000	-404400
4054	2014	-379.6	2014	-379.6	2014	-379.6	2094000	-394800
4118.65	1944	-370	1944	-370	1944	-370	2022000	-384700
4122.65	1873	-360.3	1873	-360.3	1873	-360.3	1948000	-374700
4233.27	1947	-114.8	1947	-114.8	1947	-114.8	2024000	-119400
4309.4	1381	-77.43	1381	-77.43	1381	-77.43	1436000	-80520
4385.5	7.035	0.0007267	-0.0006737	-7.035	-0.0006737	-7.035	-0.7006	-7315

**NLS1 CORE BUILDUP/SHUTDOWN W/O STME OUT
COMPOSITE AXIAL SHEAR LOADS VS X-STATION**

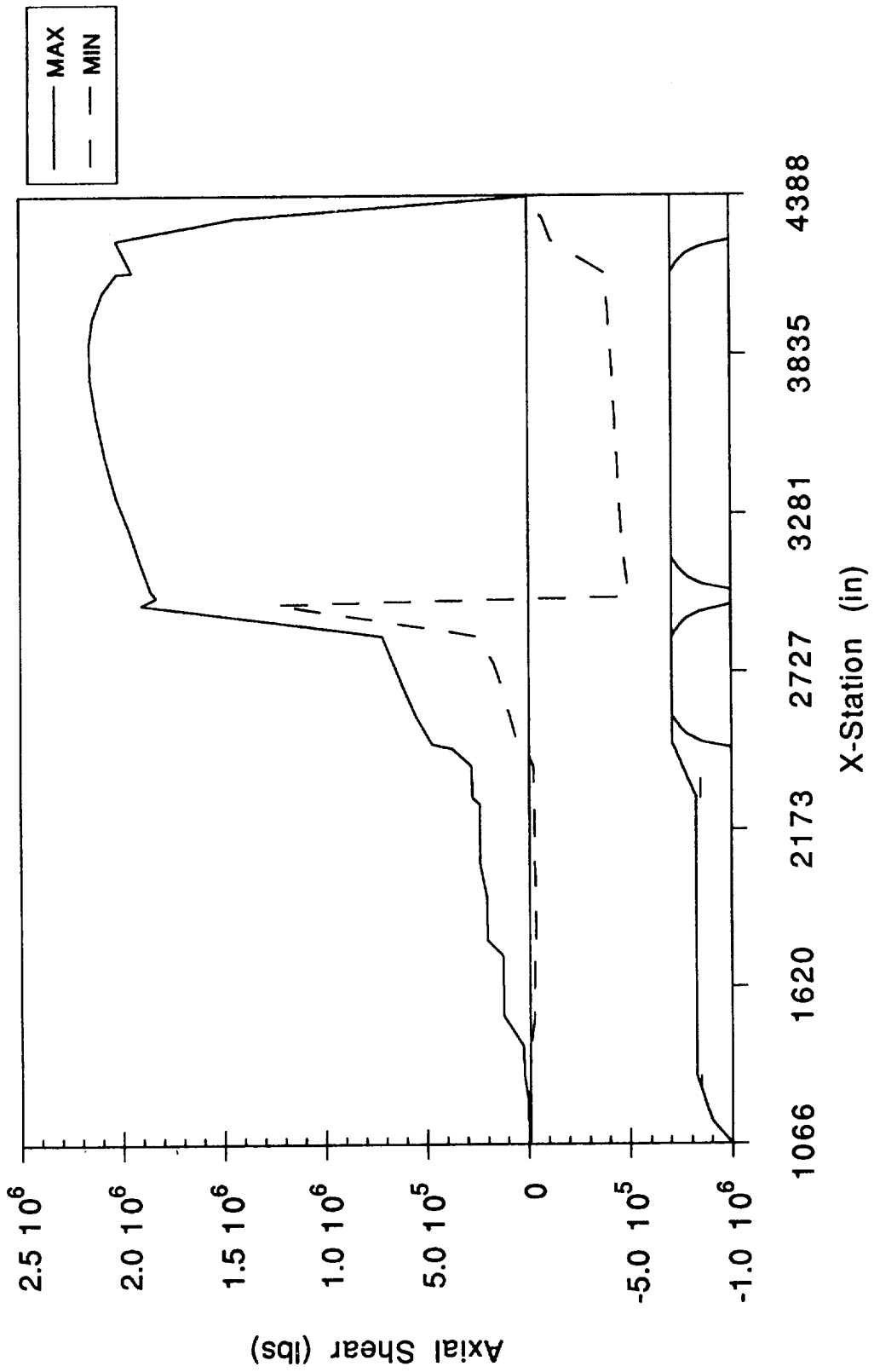

NLS1 CORE BUILDUP/SHUTDOWN W/O STME OUT COMPOSITE Y-DIR SHEAR LOADS VS X-STATION

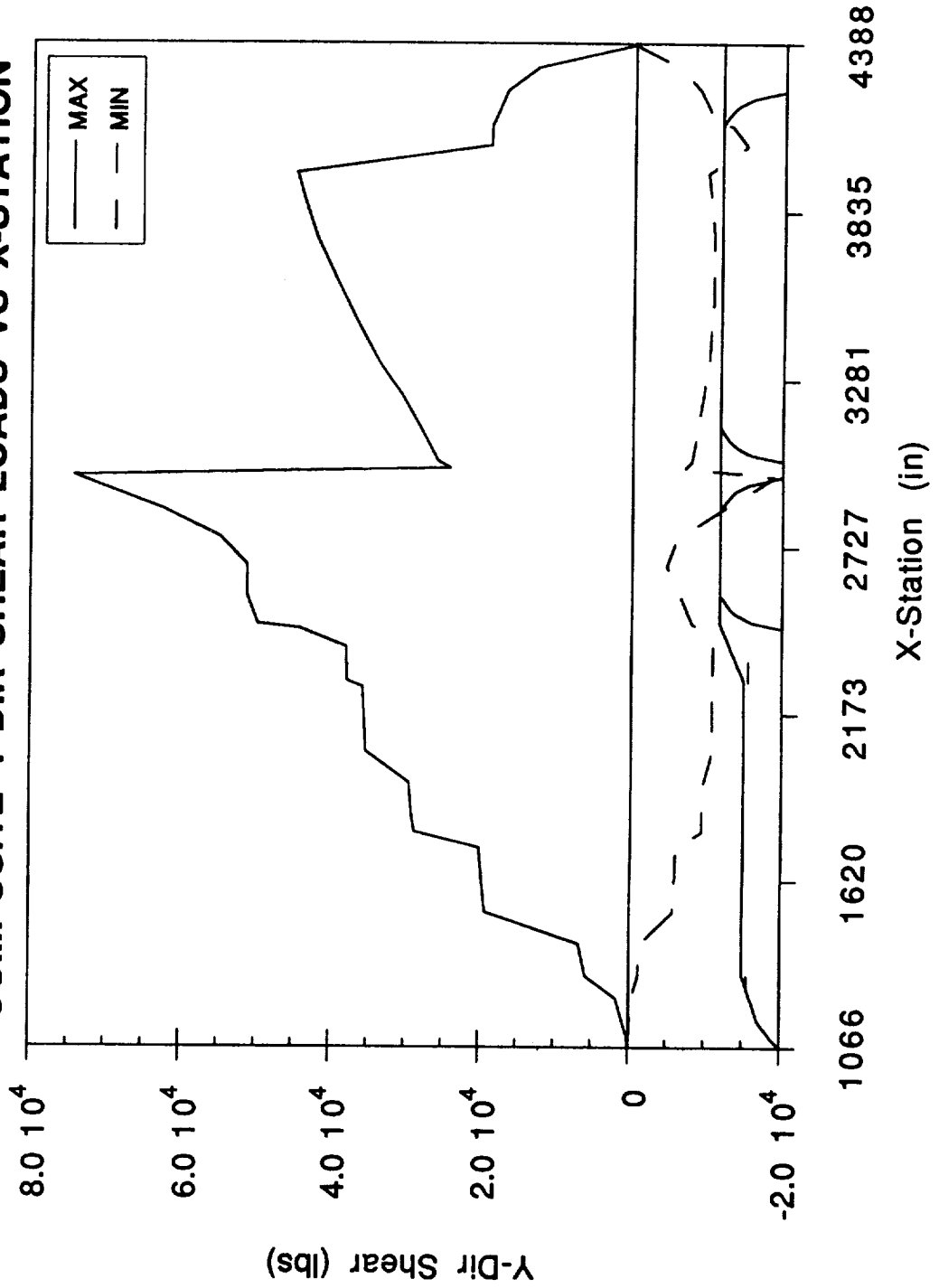

(((

**NLS1 CORE BUILDUP/SHUTDOWN W/O STME OUT
COMPOSITE Z-DIR SHEAR LOADS VS X-STATION**

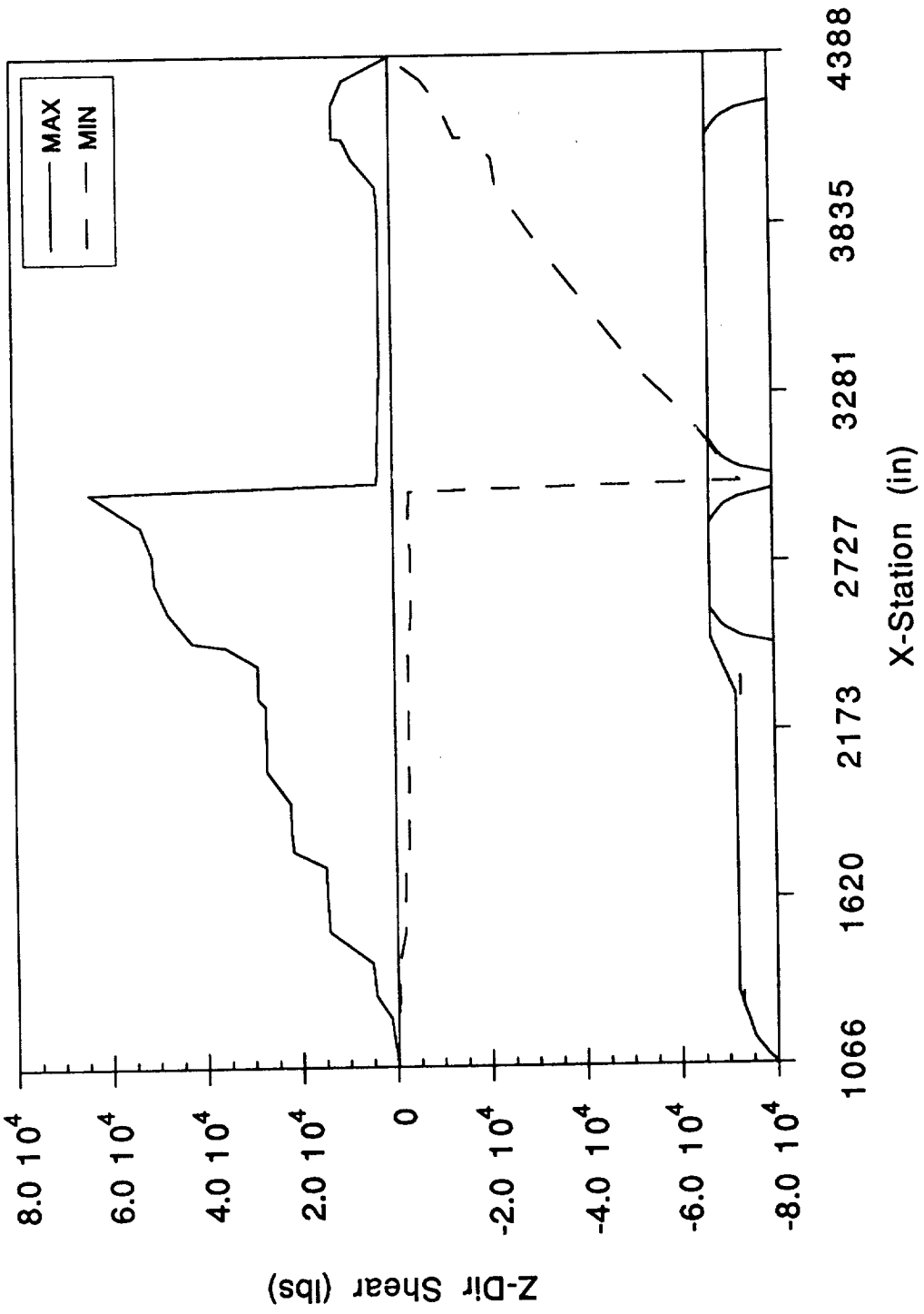

NLS1 CORE BUILDUP/SHUTDOWN W/O STME OUT COMPOSITE X-DIR TORSION VS X-STATION

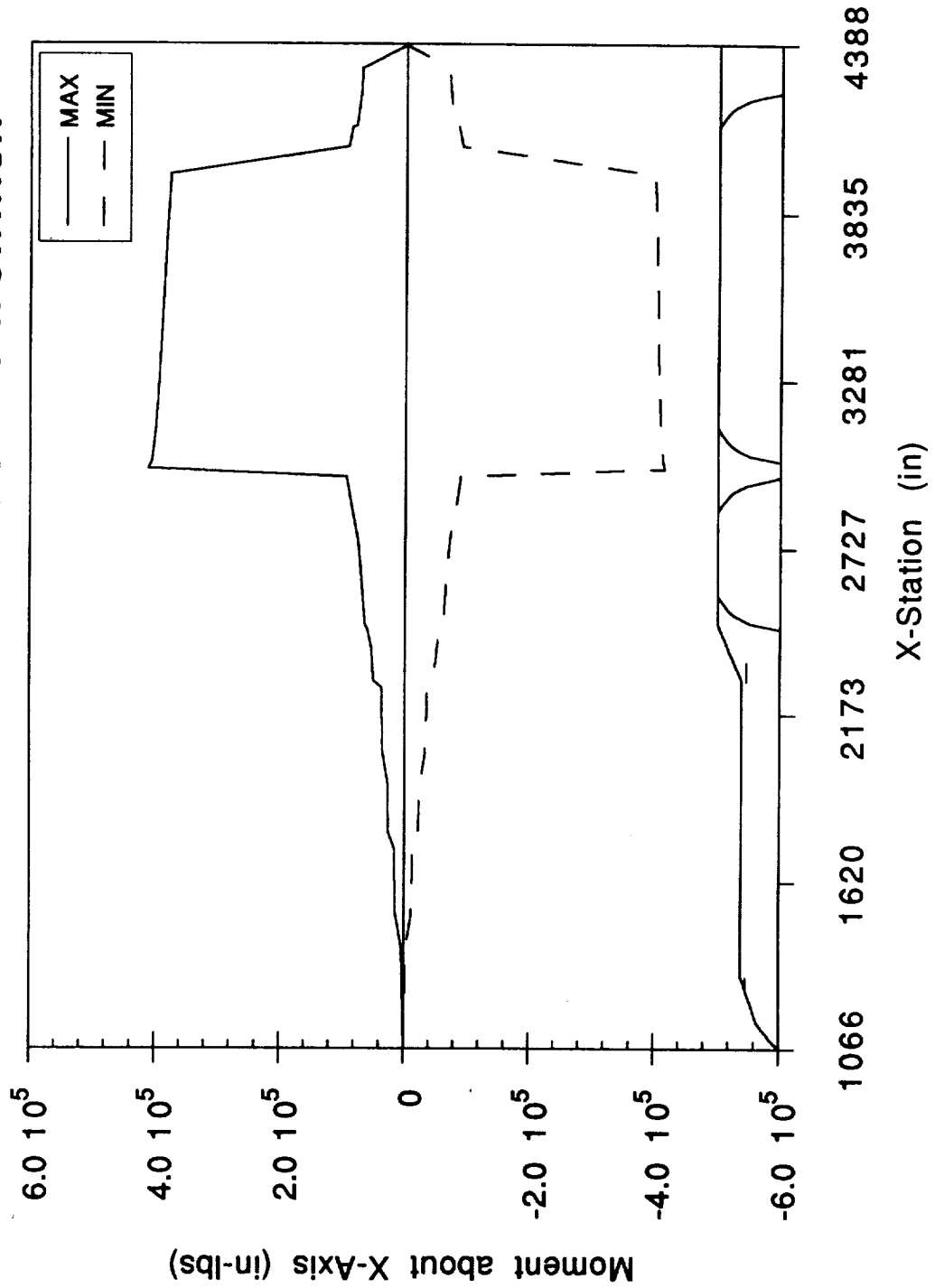

((

**NLS1 CORE BUILDUP/SHUTDOWN W/O STME OUT
COMPOSITE Y-DIR MOMENT VS X-STATION**

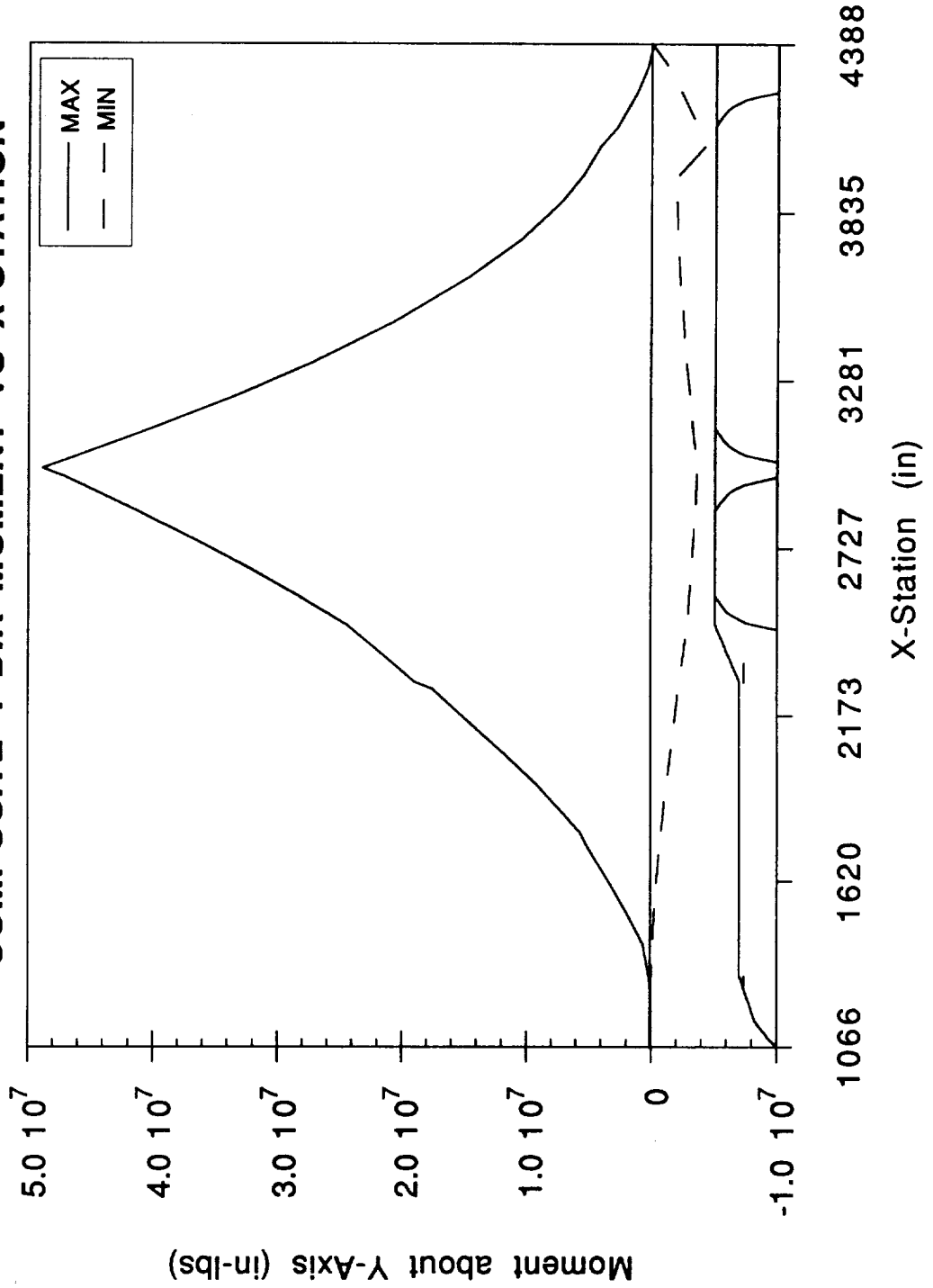

NLS1 CORE BUILDUP/SHUTDOWN W/O STME OUT COMPOSITE Z-DIR MOMENT VS X-STATION

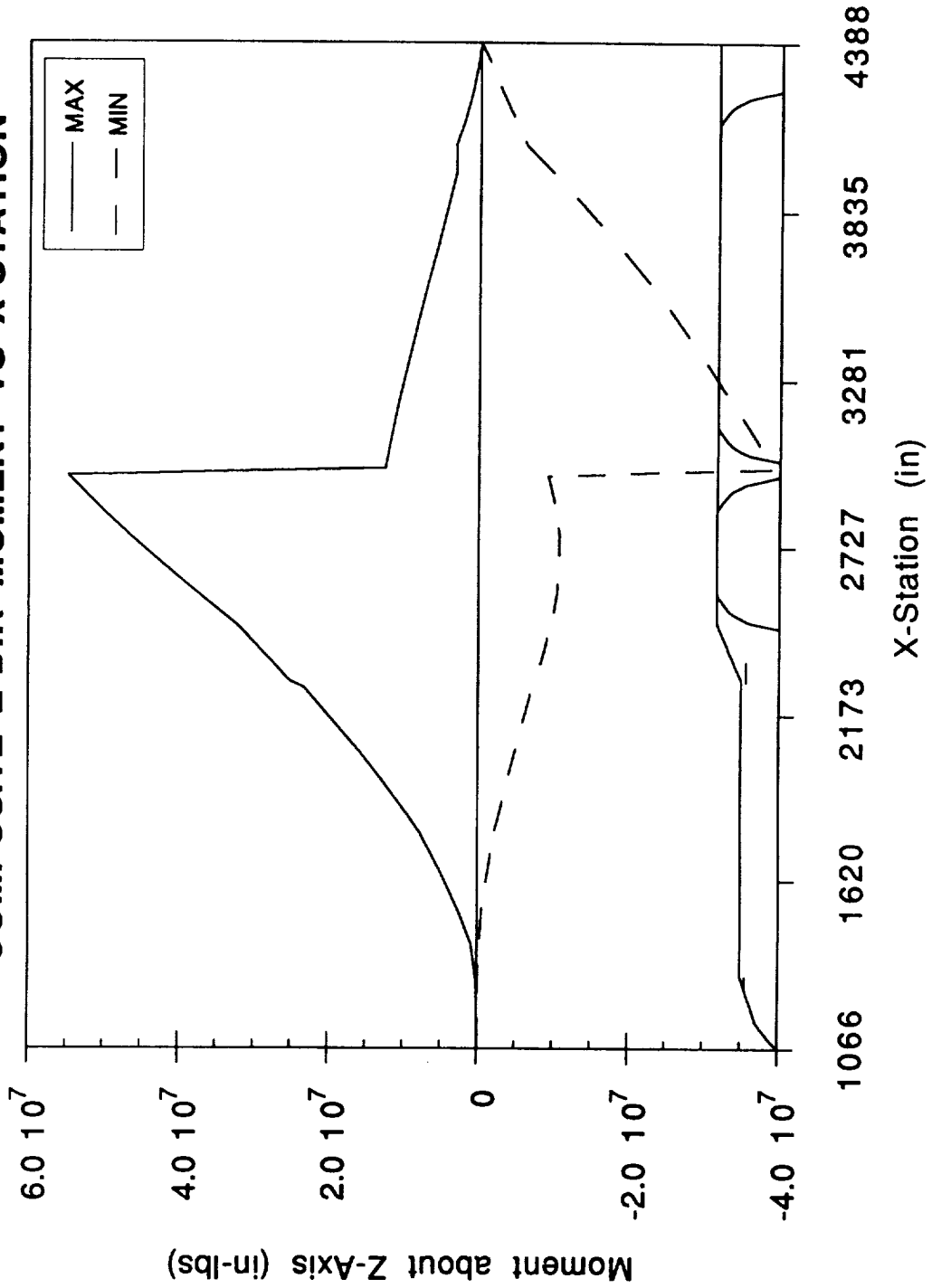

(

(

(

**NLS1 CORE BUILDUP/SHUTDOWN W/O STME OUT
COMPOSITE NX+ LOADS VS X-STATION**

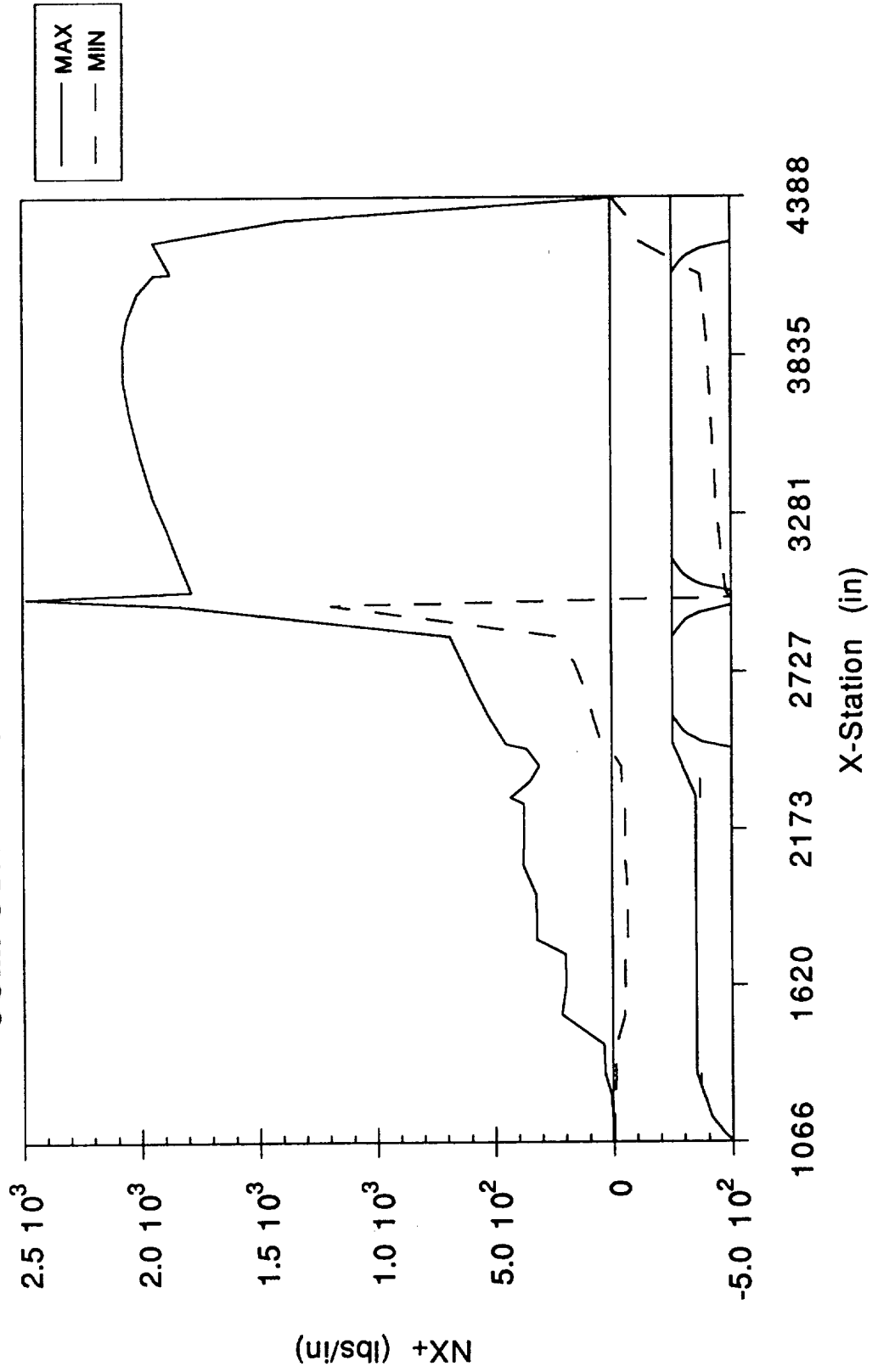

NLS1 CORE BUILDUP/SHUTDOWN W/O STME OUT COMPOSITE NX- LOADS VS X-STATION

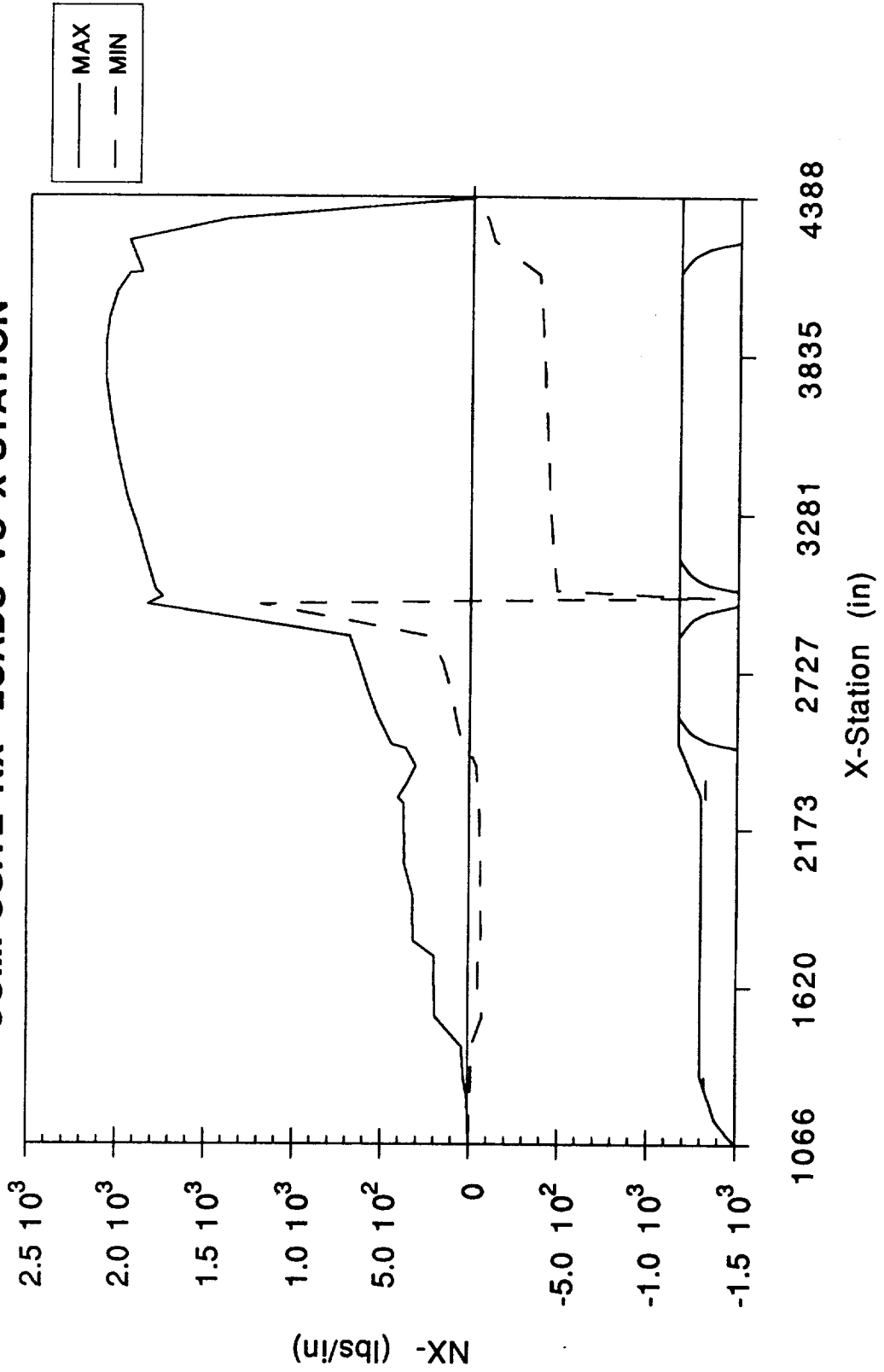

(

(

(

NLS 2

PRELAUNCH DATA

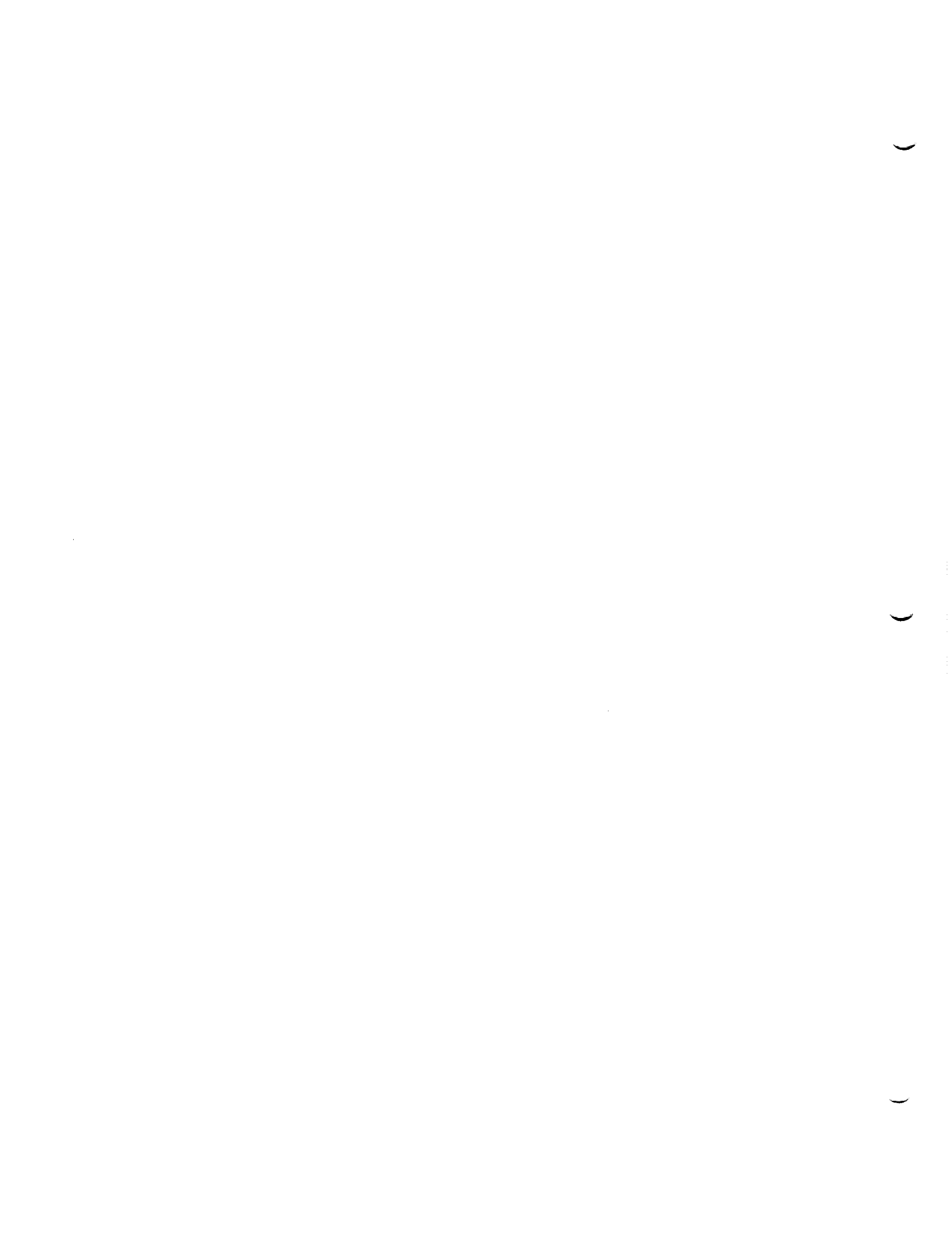

NLS2 WITH STME OUT BUILDUP/SHUTDOWN PAD FORCES (KIPS)

PAD NUMBER	MAXIMUM			MINIMUM		
	X-DIR	Y-DIR	Z-DIR	X-DIR	Y-DIR	Z-DIR
M1	319.8	95.1	30.3	-975.2	-64.6	-43.7
M2	709.3	67.6	21.1	-587.2	-80.9	-35.1
M3	717.5	38	21	-596.8	-65.1	-39.3
M4	283.9	46.3	59	-942.1	-44.2	-27.7

NLS2 WITH OUT STME OUT BUILDUP/SHUTDOWN PAD FORCES (KIPS)

PAD NUMBER	MAXIMUM			MINIMUM		
	X-DIR	Y-DIR	Z-DIR	X-DIR	Y-DIR	Z-DIR
M1	319.8	24.9	15.9	-913.2	-62.8	-40.4
M2	708.6	54.7	5.1	-498.9	-76.5	-18.1
M3	717.5	33.7	12.2	-512.9	-63.8	-39.3
M4	283.9	37.9	3.3	-885.3	-39.8	-26.7

NLS2 LV Buildup/Shutdown Accelerations (G's)

	W/ STME Out		W/O STME Out	
	Maximum	Minimum	Maximum	Minimum
Node 999 Payload 50K X-Dir	3.953	-2.314	3.185	-1.113
Node 999 Payload 50K Y-Dir	0.8961	-0.8975	0.1402	-0.1661
Node 999 Payload 50K Z-Dir	0.8559	-0.7633	0.07746	-0.08507
Node 80 LO2 Slosh X-Dir	1.1613	0.7755	1.1012	0.8905
Node 81 LH2 Slosh X-Dir	1.8847	0.3323	1.4066	0.3892

NLS2 GROUND WIND LOADS UNFUELED, UNPRESSURIZED, ON PAD WITH SIDE AND BROADSIDE WINDS

14-Day Wind				180-Day Wind				
X-Station (in)	Shear Forces		Moment About		Shear Forces		Moment About	
	Z-Direction (lbs)	Y-Direction (lbs)	Y-Axis (in-lbs)	Z-Axis (in-lbs)	Z-Direction (lbs)	Y-Direction (lbs)	Y-Axis (in-lbs)	Z-Axis (in-lbs)
1306.6	540.27	540.27	0	0	765.01	765.01	0	0
1395.1	1978.99	1978.99	-48105.39	-48105.39	2803.23	2803.23	-68116.25	-68116.25
1444.87	3410.32	3410.32	-146599.61	-146599.61	4832.25	4832.25	-207632.85	-207632.85
1494.67	5096.66	5096.66	-316331.05	-316331.05	7224.11	7224.11	-448133.69	-448133.69
1544.4	7581.17	7581.17	-569940.8	-569940.8	10750.42	10750.42	-807605.03	-807605.03
1624.4	10684.37	10684.37	-1176434.51	-1176434.51	15158.34	15158.34	-1667637.98	-1667637.98
1704.4	13771.93	13771.93	-2031184.29	-2031184.29	19548.13	19548.13	-2880304.74	-2880304.74
1784.4	16843.58	16843.58	-3132939.18	-3132939.18	23919.42	23919.42	-4444155.01	-4444155.01
1864.4	19899.18	19899.18	-4480426.14	-4480426.14	28272.02	28272.02	-6357708.69	-6357708.69
1944.4	22938.4	22938.4	-6072360.91	-6072360.91	32605.53	32605.53	-8619470.71	-8619470.71
2024.4	25960.95	25960.95	-7907432.93	-7907432.93	36919.6	36919.6	-11227913.89	-11227913.89
2104.4	28974.08	28974.08	-9984308.67	-9984308.67	41224.6	41224.6	-14181482.88	-14181482.88
2184.8	31962.45	31962.45	-12313824.19	-12313824.19	45498.59	45498.59	-17495941.41	-17495941.41
2264.4	33845.27	33845.27	-14858034.5	-14858034.5	48193.52	48193.52	-21117630.07	-21117630.07
2284.8	35557.48	35557.48	-15548477.73	-15548477.73	50646.1	50646.1	-22100778.19	-22100778.19
2347.8	38488.22	38488.22	-17788597.93	-17788597.93	54846.93	54846.93	-25291483.37	-25291483.37
2410.8	41438.38	41438.38	-20213354.46	-20213354.46	59079.05	59079.05	-28746840.94	-28746840.94
2459.175	43173.79	43173.79	-22217935.06	-22217935.06	61569.96	61569.96	-31604790.61	-31604790.61
2471.15	46505.79	46505.79	-22734940.97	-22734940.97	66355.88	66355.88	-32342090.98	-32342090.98
2569.8	52294.11	52294.11	-27322735.66	-27322735.66	74678.12	74678.12	-38888098.85	-38888098.85
2664.133	57907.78	57907.78	-32255794.45	-32255794.45	82760.59	82760.59	-45932710.33	-45932710.33
2758.467	63476.78	63476.78	-37718465.35	-37718465.35	90790.03	90790.03	-53739848.6	-53739848.6
2852.8	69472.25	69472.25	-43706419	-43706419	99447.79	99447.79	-62304345.29	-62304345.29
2963.425	73331.19	73331.19	-51391785.25	-51391785.25	105027.11	105027.11	-73305757.88	-73305757.88
2985.675	74749.88	74749.88	-53023404.01	-53023404.01	107080.05	107080.05	-75642611.19	-75642611.19
3012.525	78701.7	78701.7	-55030437.95	-55030437.95	112803.64	112803.64	-78517710.73	-78517710.73
3123.15	85187.1	85187.1	-63736812.31	-63736812.31	122210.03	122210.03	-90996614.52	-90996614.52
3240.006	91771.49	91771.49	-73691435.2	-73691435.2	131779.17	131779.17	-105277591.3	-105277591.3
3356.863	96269.77	96269.77	-84415575.26	-84415575.26	141243.73	141243.73	-120676911.1	-120676911.1
3473.719	104681.42	104681.42	-95898987.09	-95898987.09	150603	150603	-137182089.3	-137182089.3
3590.575	111004.52	111004.52	-108131638.4	-108131638.4	159854.46	159854.46	-154780954.1	-154780954.1
3707.431	117229.23	117229.23	-121103182.2	-121103182.2	168985.1	168985.1	-173460907.3	-173460907.3
3824.288	123352.38	123352.38	-134802237.7	-134802237.7	177990.72	177990.72	-193207999	-193207999
3941.144	129373.49	129373.49	-149216702.5	-149216702.5	186870.69	186870.69	-214007282.7	-214007282.7
4058	133163.85	133163.85	-164334770.1	-164334770.1	192473.26	192473.26	-235844243.7	-235844243.7
4090.325	134788.96	134788.96	-168639291.3	-168639291.3	194879.36	194879.36	-242065941.8	-242065941.8
4122.65	136693.04	136693.04	-172996344.2	-172996344.2	197701.38	197701.38	-248365417.1	-248365417.1
4166.57	138866.56	138866.56	-178999902.1	-178999902.1	200926.43	200926.43	-257048461.8	-257048461.8
4210.32	140364.31	140364.31	-185075313.6	-185075313.6	203151.02	203151.02	-265838993.2	-265838993.2
4227.37	141436.27	141436.27	-187468524.9	-187468524.9	204744.55	204744.55	-269302718.1	-269302718.1
4254.07	143153.13	143153.13	-191244872.9	-191244872.9	207298.97	207298.97	-274769377.8	-274769377.8
4297.82	145270.41	145270.41	-197507821.6	-197507821.6	210452.75	210452.75	-283838727.9	-283838727.9
4341.57	147374.65	147374.65	-203863401.3	-203863401.3	213591.28	213591.28	-293046035.8	-293046035.8
4385.5	148423.12	148423.12	-210337569.2	-210337569.2	215156.5	215156.5	-302429100.7	-302429100.7

NLS2 PRELAUNCH STATIC TRANSVERSE SHEAR VS X-STATION

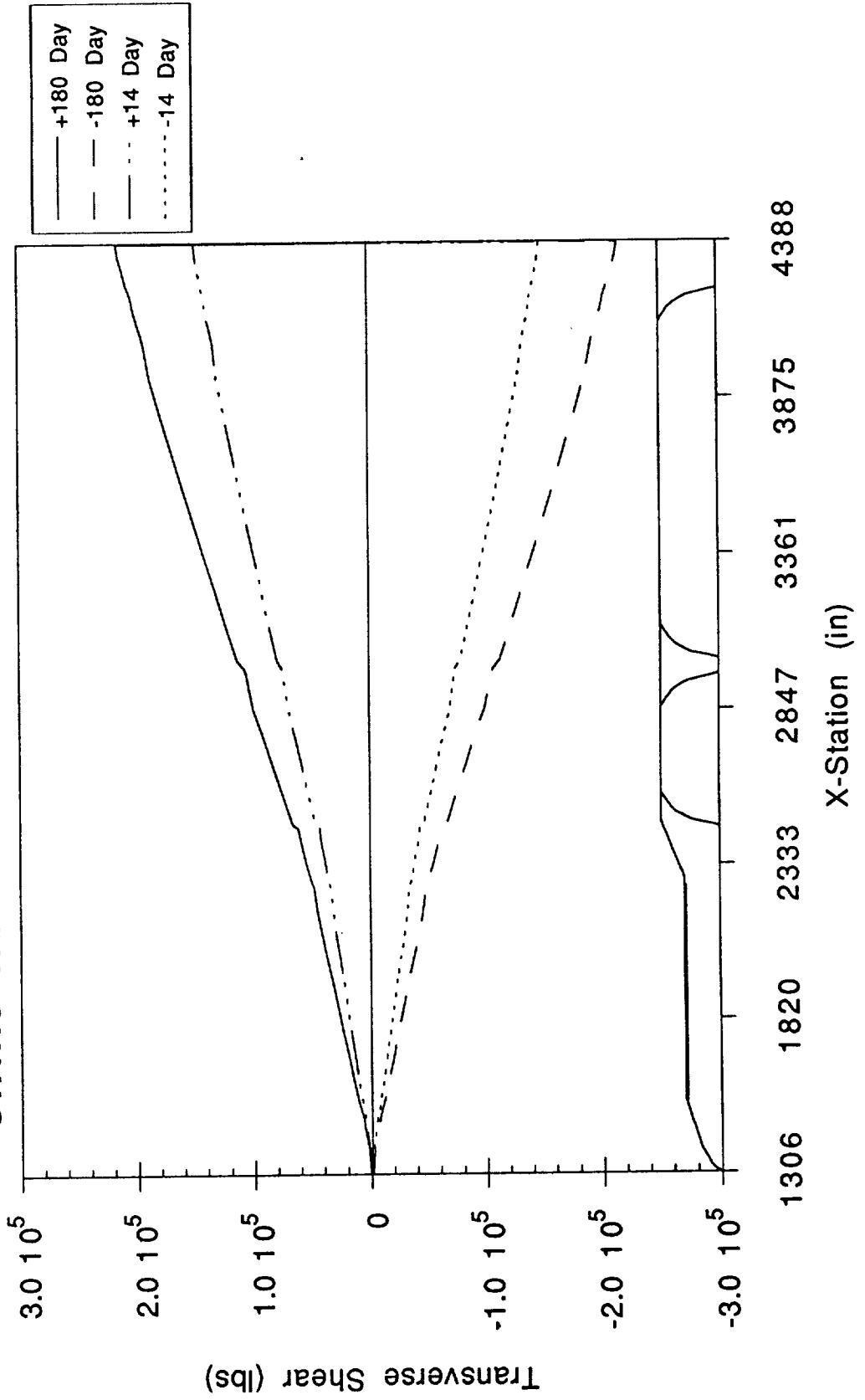

NLS2 PRELAUNCH STATIC BENDING MOMENT VS X-STATION

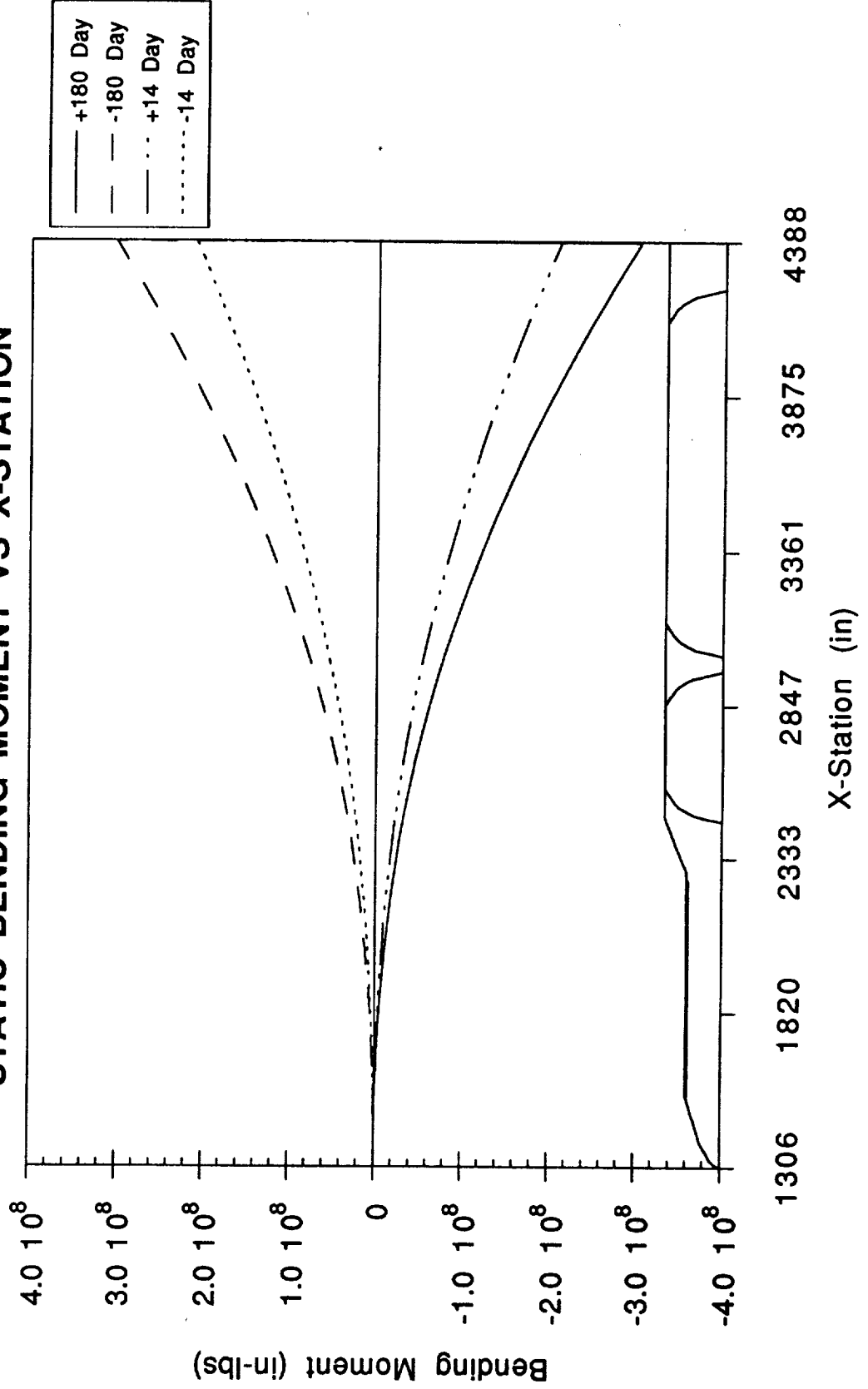

(((

NLS2 COMPOSITE SHEAR BODY LOADS W/STME OUT (LBS)

BUILD-UP AND SHUT-DOWN

X-Station (in)	X-Dir.		Y-Dir.		Z-Dir.	
	Maximum	Minimum	Maximum	Minimum	Maximum	Minimum
1306.1	80.93	-50.79	152.2	-100.1	94.72	-124.1
1395.1	1295	-812.2	2169	-1359	1426	-1666
1444.9	3508	-2198	5582	-3413	3766	-4154
1494.6	7832	-4889	11750	-6962	8177	-8404
1544.4	10690	-6647	15520	-9015	11010	-10830
1624.4	13490	-8312	18720	-10570	13650	-12610
1704.4	16200	-9858	21360	-11640	16040	-13810
1784.4	18800	-11270	23460	-12330	18140	-14540
1864.4	21290	-12510	25040	-13040	19870	-14910
1944.4	23640	-13580	26170	-13510	21210	-15030
2024.4	25860	-14460	26900	-13780	22160	-14990
2104.4	27920	-15130	27340	-13880	22740	-14880
2184.4	29820	-15580	27860	-13860	23080	-14750
2264.4	31550	-15810	41720	-42590	42720	-37360
2284.8	227000	-95910	42200	-42430	43230	-37720
2347.8	227800	-95300	42400	-42290	43500	-38130
2410.8	228000	-94230	123400	-66500	133000	-81930
2459.2	283600	-33800	240700	-119700	244800	-135200
2471.1	403400	-28100	199600	-110000	180700	-62900
2569.8	497000	24740	151100	-66730	167800	-98360
2664.1	540400	88040	185900	-92540	162800	-116600
2758.5	539700	140600	121200	-119500	133700	-116700
2852.8	569800	190000	8820	-86750	139500	-80750
2963.4	635700	238100	89030	-86910	139800	-82020
2985.7	1755000	1240000	91560	-85190	142200	-90370
3012.5	1767000	1246000	95610	-73200	145300	-85760
3123.1	1778000	1268000	99110	-58620	148000	-52540
3240	1781000	1289000	102700	-52240	150700	-60640
3356.9	1781000	1313000	106500	-63570	153200	-78410
3473.7	1785000	1332000	109600	-69200	154600	-101100
3590.6	1793000	1339000	112200	-77460	154700	-95600
3707.4	1802000	1337000	114600	-92820	154000	-108000
3824.3	1805000	1334000	116600	-101500	153700	-115700
3941.1	1806000	1332000	117900	-110500	152300	-128500
4058	1812000	1340000	118900	-121100	150200	-142500
4090.3	1822000	1353000	136400	-135200	147500	-158700
4122.6	1836000	1373000	167300	-190300	170300	-209100
4166.6	2053000	1542000	135000	-178600	142300	-186800
4210.3	2076000	1577000	119800	-174400	139900	-177000
4227.4	2084000	1589000	118600	-147600	138000	-148300
4254	2118000	1640000	119000	-135600	135900	-140600
4297.8	2108000	1644000	119400	-121600	134000	-131700
4341.6	2047000	1557000	0.5038	-0.01113	0.9783	0.3295
4385.5	0.6514	-0.2226				

NLS2 COMPOSITE MOMENT BODY LOADS W/STME OUT (IN-LBS)

BUILD-UP AND SHUT-DOWN

X-Station (in)	X-Dir.		Y-Dir.		Y-Dir.		Z-Dir.	
	Maximum	Minimum	Maximum	Minimum	Maximum	Minimum	Maximum	Minimum
1306.1	3794	-3893	0.002345	0.0001585	0.001641	-0.004091		
1395.1	27790	-28510	8434	-11050	13550	-8912		
1444.9	59310	-60860	79400	-93940	121500	-76570		
1494.6	127000	-130300	266800	-300700	399300	-246400		
1544.4	707700	-726100	673700	-718900	984000	-592900		
1624.4	1050000	-1077000	1554000	-1585000	2226000	-1314000		
1704.4	1223000	-1253000	2643000	-2594000	3723000	-2159000		
1784.4	1295000	-1326000	3927000	-3699000	5432000	-3090000		
1864.4	1324000	-1353000	5378000	-4862000	7308000	-4072000		
1944.4	1344000	-1371000	6967000	-6053000	9312000	-5075000		
2024.4	1377000	-1393000	8665000	-7251000	11410000	-6073000		
2104.4	1423000	-1413000	10440000	-8445000	13560000	-7131000		
2184.4	1466000	-1396000	12260000	-9630000	15740000	-8242000		
2264.4	1469000	-1289000	14100000	-10810000	17950000	-9350000		
2284.8	3916000	-3349000	20050000	-17090000	17250000	-18910000		
2347.8	3960000	-3339000	21600000	-19100000	19660000	-21580000		
2410.8	3954000	-3276000	23100000	-21100000	22130000	-24240000		
2459.2	3794000	-2786000	24230000	-22630000	24020000	-26270000		
2471.1	3650000	-2403000	24500000	-22660000	23990000	-26500000		
2569.8	3487000	-2090000	33670000	-28650000	25970000	-28170000		
2664.1	3356000	-1987000	43060000	-31540000	31580000	-27850000		
2758.5	3200000	-2014000	54060000	-24900000	38190000	-23440000		
2852.8	2561000	-2124000	65970000	-22980000	45650000	-23760000		
2963.4	2916000	-2227000	79280000	-21570000	53920000	-25410000		
2985.7	2916000	-2227000	82020000	-22260000	55720000	-25450000		
3012.5	7964000	-6422000	85330000	-23100000	57860000	-25500000		
3123.1	5194000	-3198000	99100000	-26510000	66920000	-25550000		
3240	5896000	-3386000	113900000	-30040000	76950000	-25580000		
3356.9	5026000	-3474000	128900000	-33470000	87780000	-25860000		
3473.7	4693000	-3509000	144100000	-36800000	98980000	-26630000		
3590.6	4153000	-3525000	159900000	-40020000	110500000	-27420000		
3707.4	4267000	-3542000	176500000	-43150000	122500000	-27820000		
3824.3	5546000	-3580000	194400000	-47440000	134700000	-28090000		
3941.1	8628000	-5505000	212400000	-51850000	147100000	-30800000		
4058	7694000	-4054000	230200000	-56050000	159700000	-33600000		
4090.3	8941000	-5963000	235000000	-57150000	163300000	-34480000		
4122.6	13510000	-6534000	239800000	-58190000	166900000	-35500000		
4166.6	14420000	-7162000	246900000	-59780000	172300000	-37370000		
4210.3	13620000	-7793000	252800000	-60990000	177300000	-39720000		
4227.4	13420000	-7897000	255100000	-61450000	179300000	-40680000		
4254	12450000	-7754000	258600000	-62200000	182400000	-42230000		
4297.8	12850000	-6831000	264400000	-63310000	187500000	-44740000		
4341.6	13450000	-7003000	270200000	-64320000	192900000	-47210000		
4385.5	8.434	-33.72	4184000	-4283000	4654000	-4381000		

NLS2 COMPOSITE LINE BODY LOADS W/STME OUT BUILD-UP AND SHUT-DOWN

X-Station (in)	NX+ (lbs/in)		NX- (lbs/in)		PEQ+ (lbs)		PEQ- (lbs)	
	Maximum	Minimum	Maximum	Minimum	Maximum	Minimum	Maximum	Minimum
1306.1	0	0	0	0	0	0	0	0
1395.1	5.887	-3.693	5.887	-3.693	1295	-812.2	1295	-812.2
1444.9	9.305	-5.83	9.305	-5.83	3508	-2198	3508	-2198
1494.6	15.58	-9.727	15.58	-9.727	7832	-4889	7832	-4889
1544.4	17.02	-10.58	17.02	-10.58	10690	-6647	10690	-6647
1624.4	21.47	-13.23	21.47	-13.23	13490	-8312	13490	-8312
1704.4	25.78	-15.69	25.78	-15.69	16200	-9858	16200	-9858
1784.4	29.92	-17.93	29.92	-17.93	18800	-11270	18800	-11270
1864.4	33.88	-19.92	33.88	-19.92	21290	-12510	21290	-12510
1944.4	37.63	-21.62	37.63	-21.62	23640	-13580	23640	-13580
2024.4	41.15	-23.01	41.15	-23.01	25860	-14460	25860	-14460
2104.4	44.43	-24.08	44.43	-24.08	27920	-15130	27920	-15130
2184.4	47.45	-24.8	47.45	-24.8	29820	-15580	29820	-15580
2264.4	50.21	-25.17	50.21	-25.17	31550	-15810	31550	-15810
2284.8	1072	-109.5	251.6	-809.3	673900	-68810	158100	-508500
2347.8	302.8	-126.7	302.8	-126.7	227800	-95300	227800	-95300
2410.8	260.4	-107.6	260.4	-107.6	228000	-94230	228000	-94230
2459.2	292.1	-34.82	292.1	-34.82	283600	-33800	283600	-33800
2471.1	405.6	-28.25	405.6	-28.25	403400	-28100	403400	-28100
2569.8	477.9	23.79	477.9	23.79	497000	24740	497000	24740
2664.1	519.7	84.66	519.7	84.66	540400	88040	540400	88040
2758.5	519	135.2	519	135.2	539700	140600	539700	140600
2852.8	548	182.7	548	182.7	569800	190000	569800	190000
2963.4	611.3	228.9	611.3	228.9	635700	238100	635700	238100
2985.7	1688	1192	1688	1192	1755000	1240000	1755000	1240000
3012.5	1699	1198	1699	1198	1767000	1246000	1767000	1246000
3123.1	1710	1219	1710	1219	1778000	1268000	1778000	1268000
3240	1713	1240	1713	1240	1781000	1289000	1781000	1289000
3356.9	1713	1263	1713	1263	1781000	1313000	1781000	1313000
3473.7	1716	1280	1716	1280	1785000	1332000	1785000	1332000
3590.6	1724	1288	1724	1288	1793000	1339000	1793000	1339000
3707.4	1733	1286	1733	1286	1802000	1337000	1802000	1337000
3824.3	1736	1283	1736	1283	1805000	1334000	1805000	1334000
3941.1	1737	1281	1737	1281	1806000	1332000	1806000	1332000
4058	1743	1288	1743	1288	1812000	1340000	1812000	1340000
4090.3	1752	1301	1752	1301	1822000	1353000	1822000	1353000
4122.6	1765	1321	1765	1321	1836000	1373000	1836000	1373000
4166.6	2000	1534	1984	1494	2080000	1595000	2033000	1368000
4210.3	2008	1529	1984	1494	2088000	1590000	2063000	1553000
4227.4	2008	1537	2001	1518	2088000	1599000	2080000	1579000
4254	2051	1600	2024	1521	2132000	1664000	2105000	1582000
4297.8	2045	1618	2013	1502	2126000	1682000	2094000	1561000
4341.6	1995	1567	1967	1392	2075000	1630000	2046000	1448000
4385.5	3276	0.2145	-0.214	-3276	3407000	223.1	-222.5	-3407000

NLS2 BUILDUP/SHUTDOWN W/STME OUT COMPOSITE AXIAL SHEAR LOADS VS X-STATION

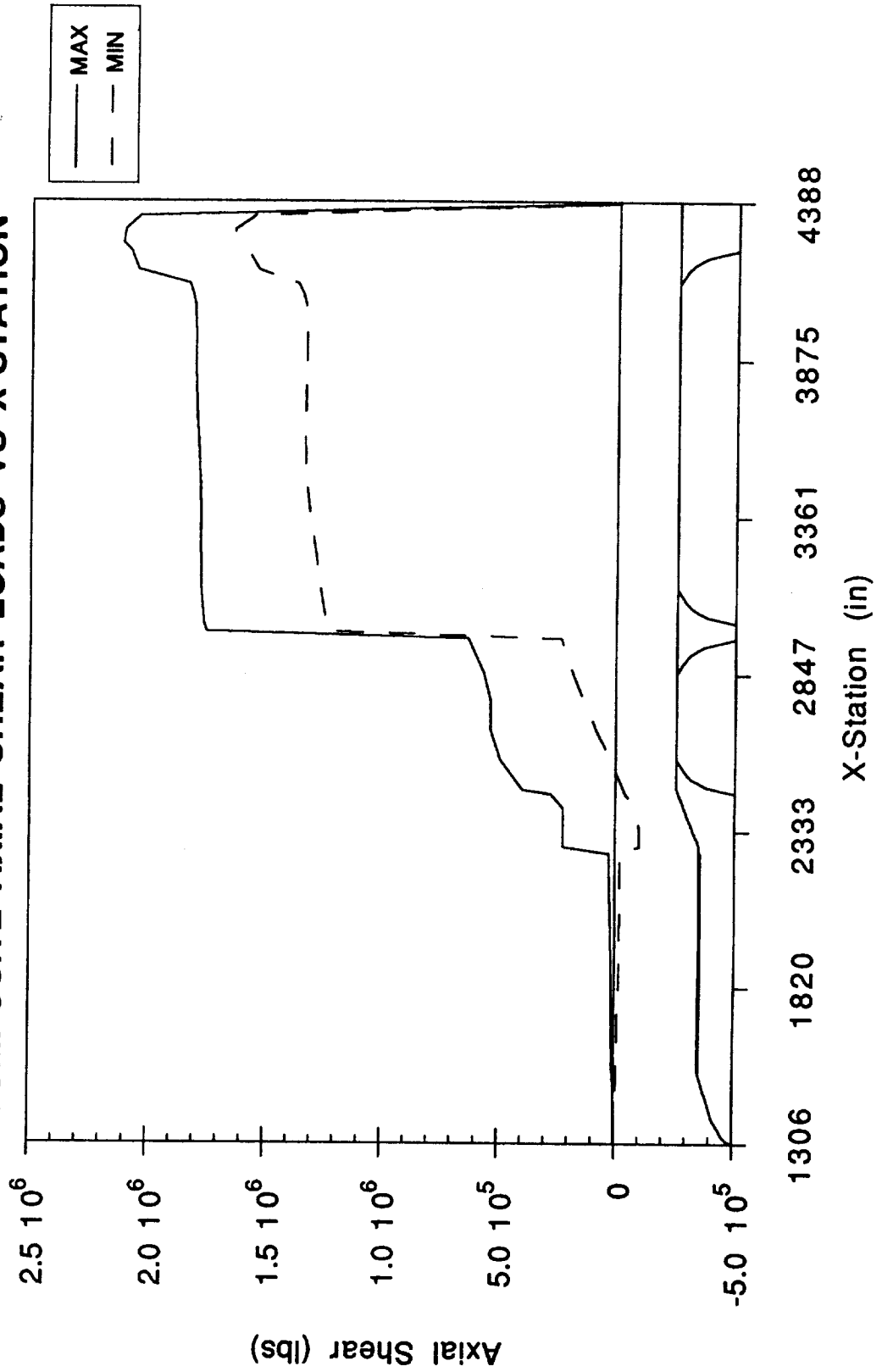

(((

**NLS2 BUILDUP/SHUTDOWN W/STME OUT
COMPOSITE Y-DIR SHEAR LOADS VS X-STATION**

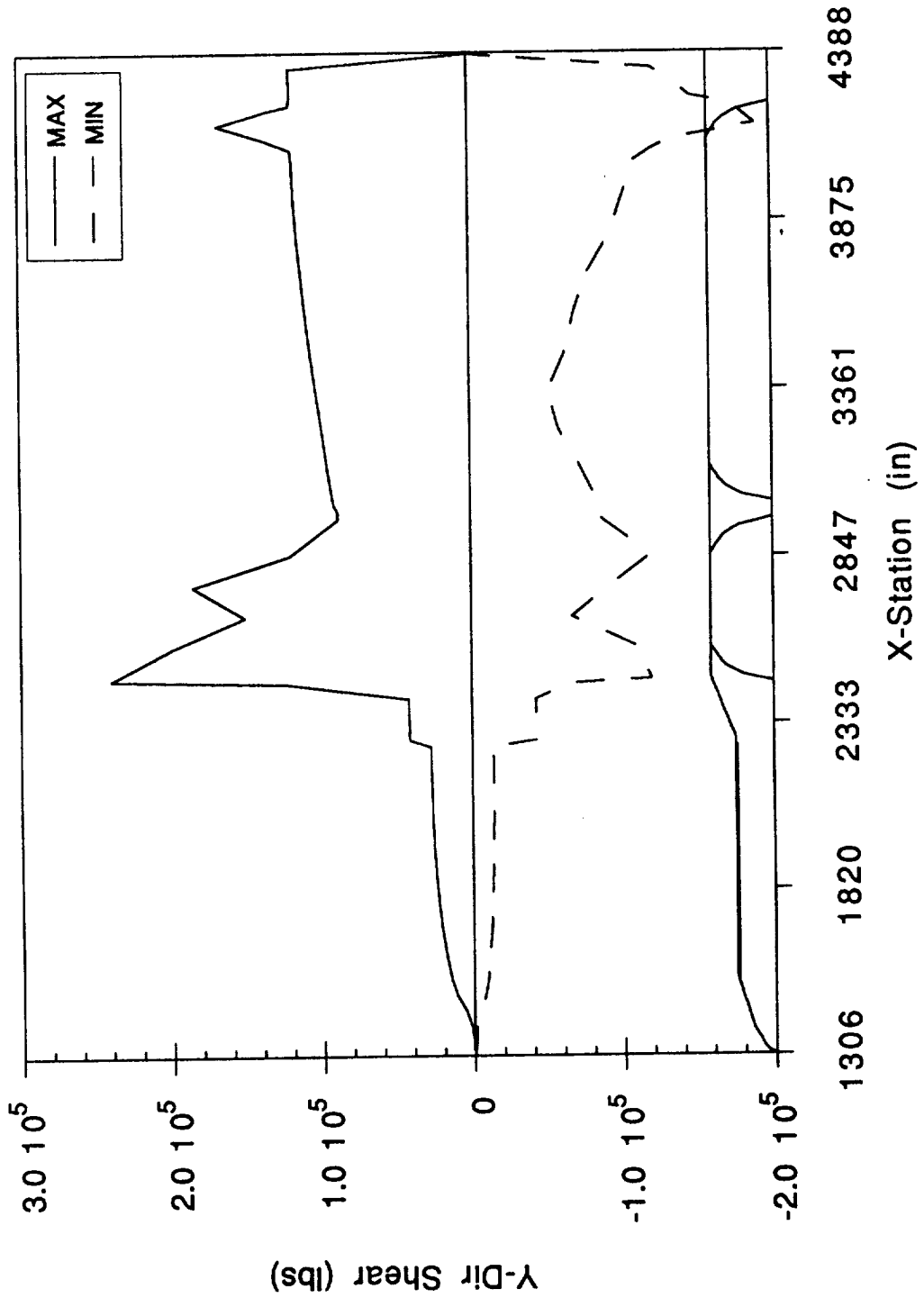

NLS2 BUILDUP/SHUTDOWN W/STME OUT COMPOSITE Z-DIR SHEAR LOADS VS X-STATION

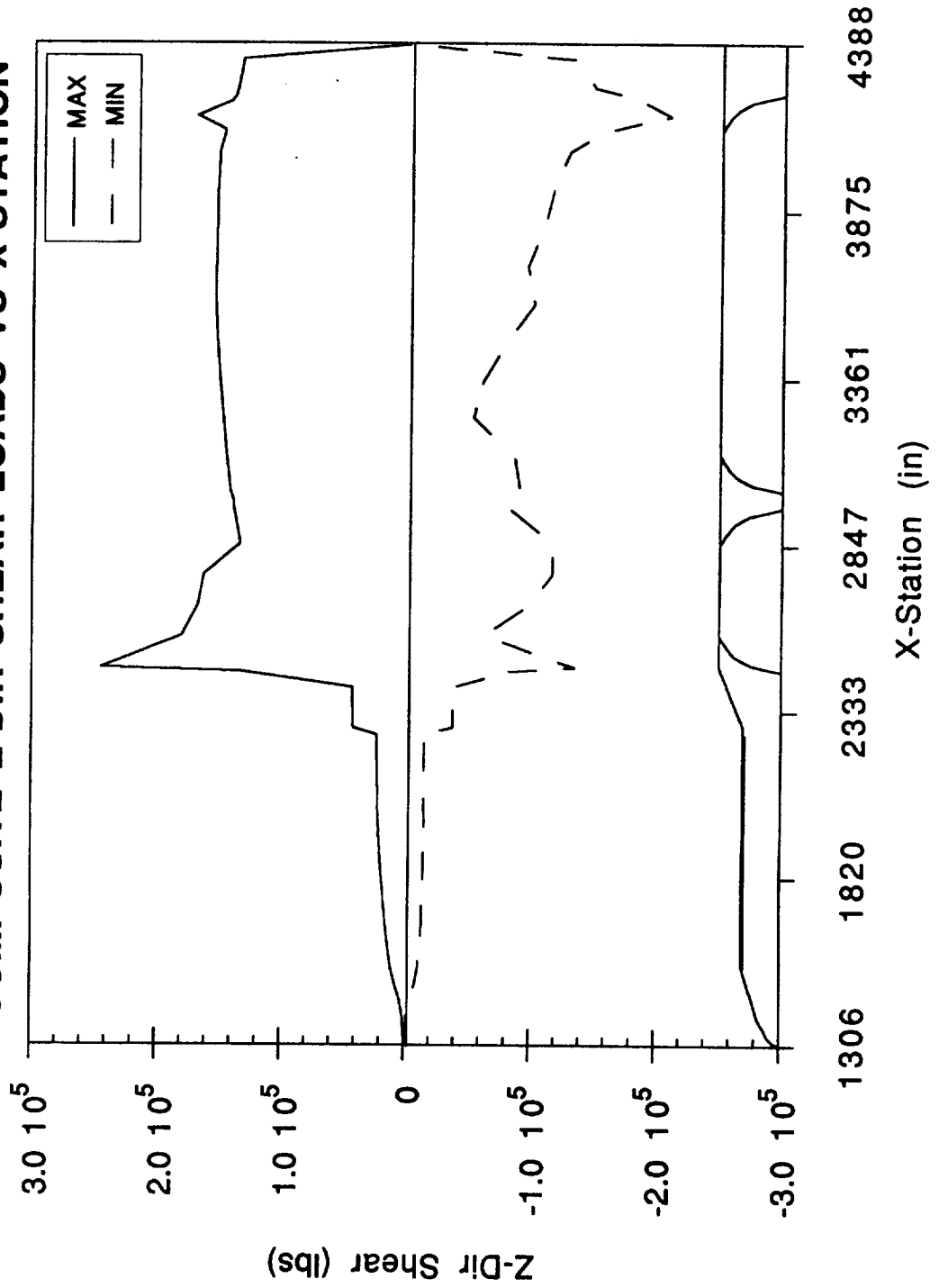

((

**NLS2 BUILDUP/SHUTDOWN W/STME OUT
COMPOSITE X-DIR TORSION VS X-STATION**

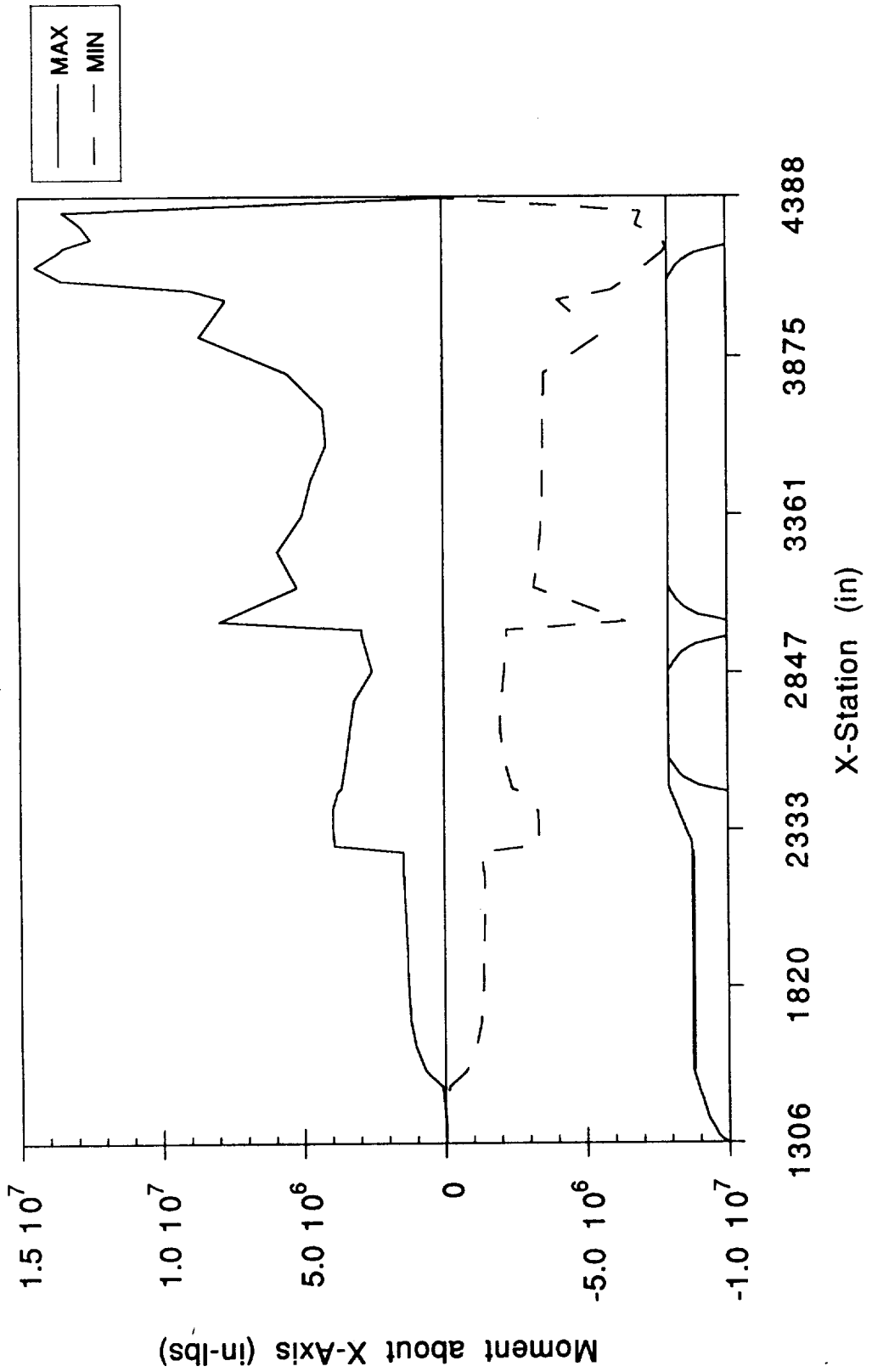

NLS2 BUILDUP/SHUTDOWN W/STME OUT COMPOSITE Y-DIR MOMENT VS X-STATION

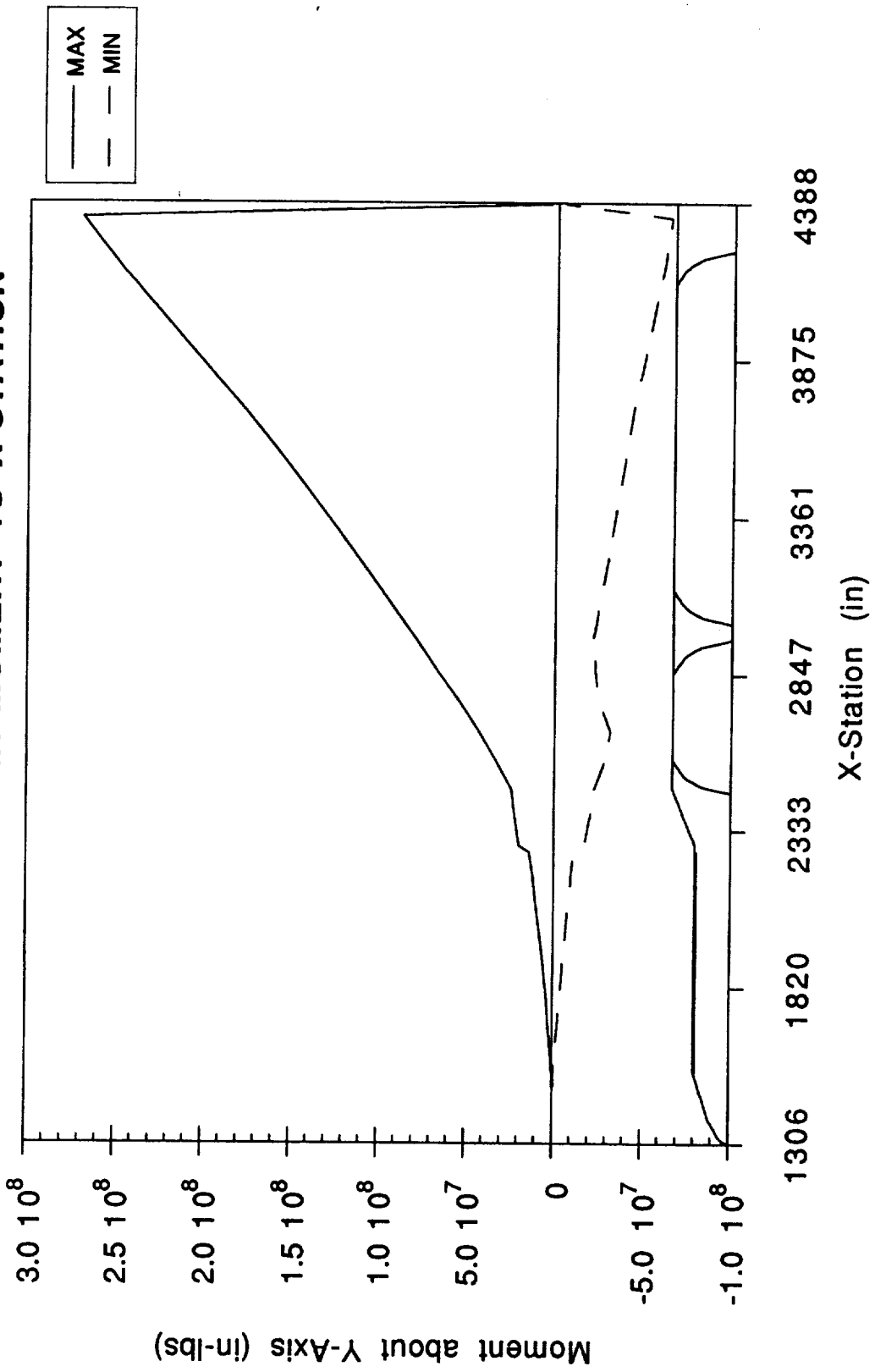

((

**NLS2 BUILDUP/SHUTDOWN W/STME OUT
COMPOSITE Z-DIR MOMENT VS X-STATION**

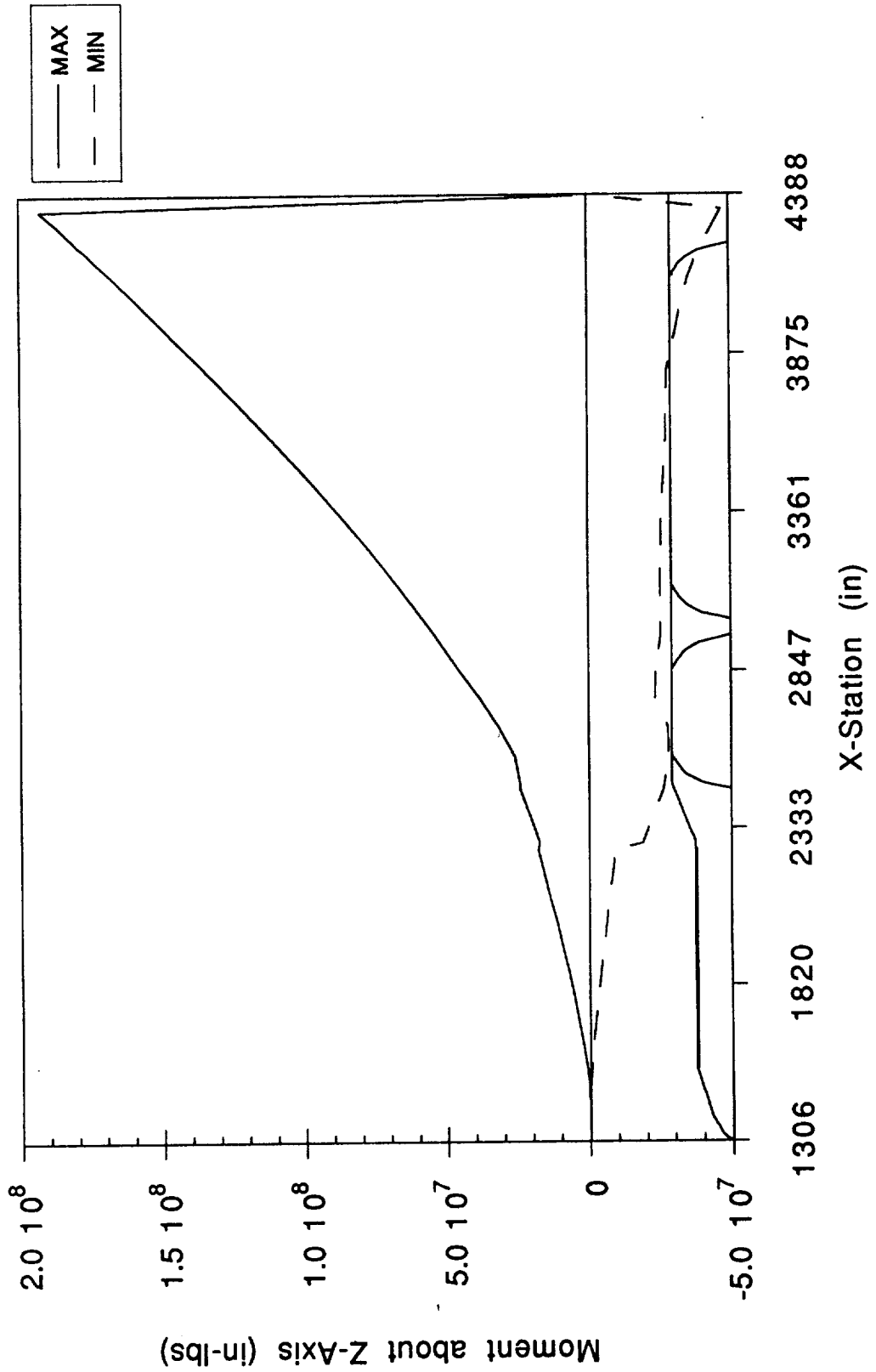

NLS2 BUILDUP/SHUTDOWN W/STME OUT COMPOSITE NX+ LOADS VS X-STATION

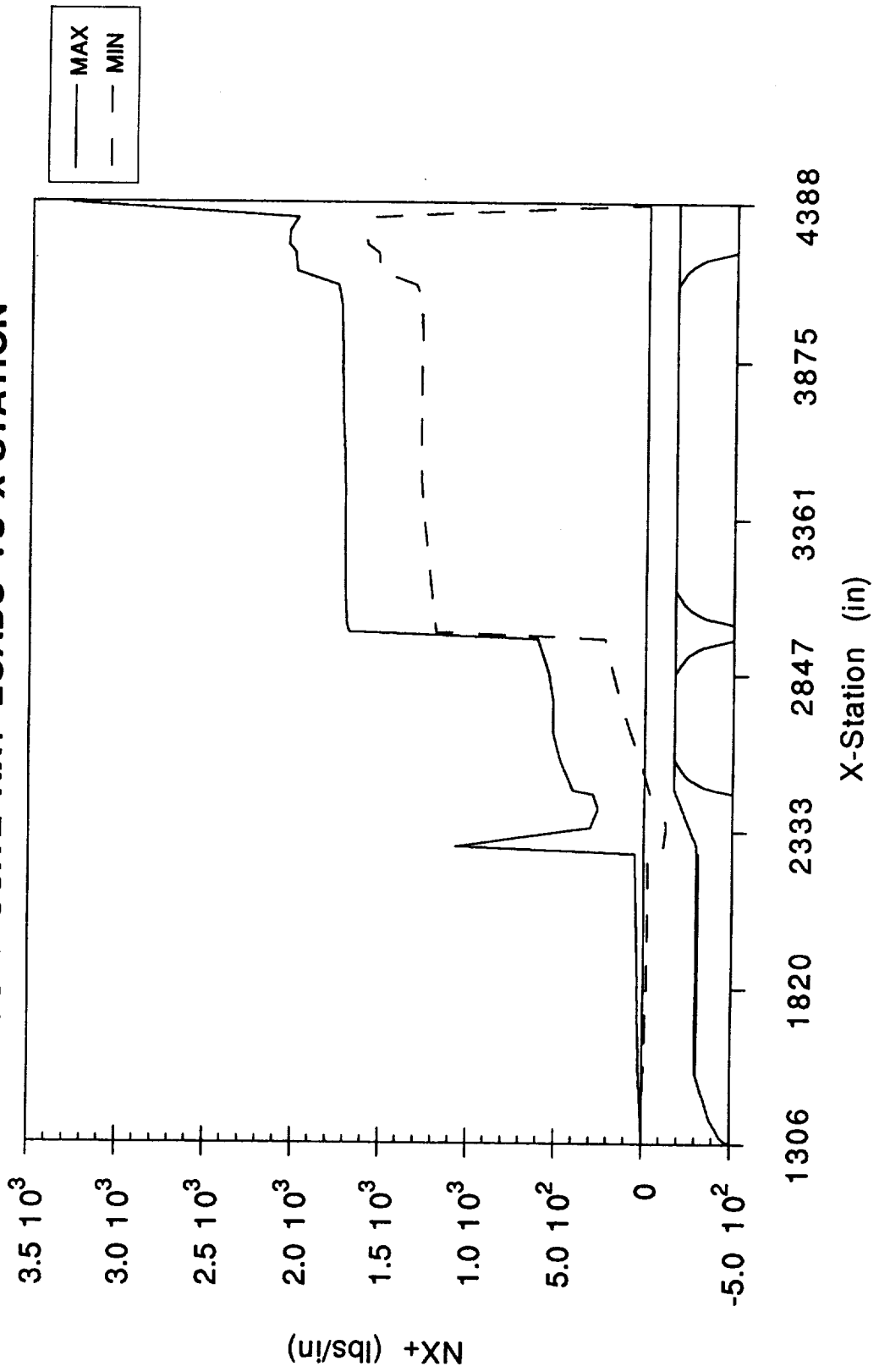

(((

**NLS2 BUILDUP/SHUTDOWN W/STME OUT
COMPOSITE NX- LOADS VS X-STATION**

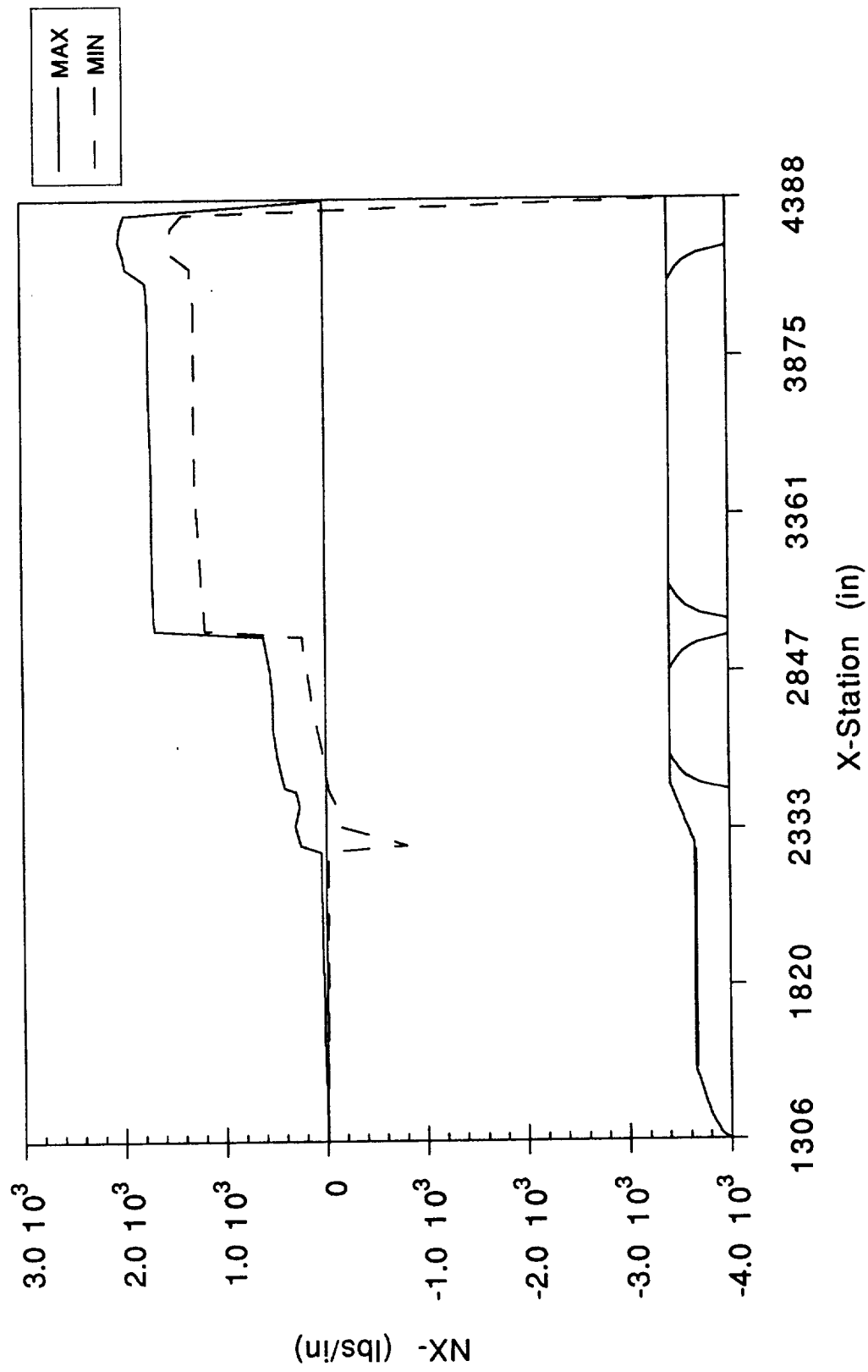

**NLS2 COMPOSITE SHEAR BODY LOADS W/O STME OUT (LBS)
BUILD-UP AND SHUT-DOWN**

X-Station (in)	X-Dir.		Y-Dir.		Z-Dir.	
	Maximum	Minimum	Maximum	Minimum	Maximum	Minimum
1306.1	64.33	-16.61	79.43	-29.89	76.47	-12.38
1395.1	1029	-265.6	1138	-418.4	1113	-171.8
1444.9	2788	-718.3	2936	-1067	2893	-436.2
1494.6	6225	-1595	6200	-2221	6167	-903
1544.4	8499	-2165	8207	-2914	8208	-1181
1624.4	10720	-2696	9929	-3480	10010	-1404
1704.4	12870	-3179	11370	-3924	11560	-1576
1784.4	14930	-3605	12540	-4253	12880	-1702
1864.4	16900	-3965	13460	-4475	13950	-1787
1944.4	18770	-4252	14140	-4603	14790	-1838
2024.4	20520	-4459	14640	-4652	15410	-1863
2104.4	22150	-4580	15010	-4640	15860	-1868
2184.4	23650	-4611	15270	-4589	16190	-1861
2264.4	25020	-4548	15500	-4522	16490	-1849
2284.8	183600	-44580	31060	-6226	36010	-6335
2347.8	185200	-43370	31350	-6216	36390	-6376
2410.8	186500	-41830	31520	-6194	36620	-6409
2459.2	241300	13110	45020	-14450	59200	-12460
2471.1	322700	42580	56230	-29000	77650	-18200
2569.8	385200	76590	52440	-30430	82470	-19870
2664.1	438600	138300	65790	-18610	100500	-22860
2758.5	499800	229600	76140	-18500	113300	-25340
2852.8	569800	338600	69920	-16870	110800	-24880
2963.4	635700	413700	74520	-10190	118400	-25530
2985.7	1718000	1387000	74770	-10200	118600	-25550
3012.5	1730000	1396000	77380	-10200	120400	-25710
3123.1	1733000	1409000	81450	-9629	122900	-25360
3240	1727000	1416000	84370	-8267	125200	-24470
3356.9	1718000	1423000	87780	-6920	127700	-23600
3473.7	1713000	1430000	92330	-6411	130300	-23250
3590.6	1722000	1438000	97140	-7775	132200	-22900
3707.4	1736000	1446000	100200	-9473	132900	-21740
3824.3	1745000	1453000	101800	-9564	132700	-20230
3941.1	1751000	1460000	103800	-8628	132000	-19390
4058	1753000	1468000	106100	-7609	130300	-19000
4090.3	1755000	1478000	108000	-10190	128200	-18440
4122.6	1757000	1490000	109000	-12440	125600	-17540
4166.6	2026000	1735000	107500	-14810	120200	-14880
4210.3	2031000	1744000	103600	-14680	121700	-11680
4227.4	2032000	1747000	103600	-16330	122800	-10900
4254	2041000	1763000	104100	-15490	120900	-10560
4297.8	2048000	1775000	105100	-13740	118200	-11560
4341.6	2047000	1756000	109300	-12250	117300	-10040
4385.5	0.6509	-0.2014	0.4898	-0.009138	0.9523	0.3295

NLS2 COMPOSITE MOMENT BODY LOADS W/O STME OUT (IN-LBS)

BUILD-UP AND SHUT-DOWN

X-Station (in)	X-Dir.		Y-Dir.		Z-Dir.	
	Maximum	Minimum	Maximum	Minimum	Maximum	Minimum
1306.1	734.5	-1047	0.002345	0.0005961	0.0005827	-0.003786
1395.1	5379	-7666	6809	-1102	7072	-2661
1444.9	11480	-16370	62200	-9652	63710	-23490
1494.6	24580	-35080	206200	-31360	209800	-76600
1544.4	137100	-196300	513100	-76300	518400	-187100
1624.4	203700	-294800	1170000	-170700	1175000	-420300
1704.4	237300	-347500	1970000	-283100	1969000	-698700
1784.4	251400	-371300	2895000	-409100	2879000	-1013000
1864.4	256700	-381300	3924000	-545300	3882000	-1353000
1944.4	260200	-389400	5040000	-688200	4959000	-1711000
2024.4	265000	-403700	6223000	-835200	6091000	-2079000
2104.4	269800	-428900	7456000	-984200	7261000	-2451000
2184.4	268500	-465400	8724000	-1134000	8457000	-2822000
2264.4	256600	-509100	10020000	-1283000	9672000	-3190000
2284.8	586900	-1381000	14340000	-2442000	13410000	-2995000
2347.8	602000	-1396000	16610000	-2841000	15360000	-3314000
2410.8	612400	-1398000	18890000	-3242000	17320000	-3629000
2459.2	660300	-1472000	20660000	-3551000	18630000	-3870000
2471.1	697300	-1556000	21370000	-3685000	19350000	-3931000
2569.8	716400	-1600000	28930000	-5300000	24380000	-4385000
2664.1	727300	-1626000	36620000	-7148000	28550000	-4527000
2758.5	738000	-1652000	45740000	-9010000	34210000	-4825000
2852.8	782500	-1760000	55760000	-10790000	41170000	-4686000
2963.4	824800	-1864000	67340000	-13010000	48340000	-4915000
2985.7	824800	-1864000	69920000	-13480000	49890000	-4873000
3012.5	1071000	-2779000	73030000	-14040000	51760000	-4817000
3123.1	1237000	-2897000	86020000	-16350000	59710000	-4435000
3240	1332000	-3144000	100000000	-18750000	68500000	-4236000
3356.9	1383000	-3282000	114300000	-21060000	77560000	-4279000
3473.7	1408000	-3350000	129000000	-23400000	86950000	-4286000
3590.6	1421000	-3387000	144100000	-25940000	96880000	-4371000
3707.4	1436000	-3433000	159400000	-28580000	107200000	-4418000
3824.3	1464000	-3526000	174900000	-31110000	117800000	-4424000
3941.1	1512000	-3717000	190300000	-33460000	128500000	-4519000
4058	1679000	-4054000	205700000	-35720000	140100000	-4885000
4090.3	1738000	-4455000	209900000	-36330000	143500000	-5005000
4122.6	2266000	-4872000	214000000	-36920000	146900000	-5117000
4166.6	2809000	-5705000	220300000	-38060000	152300000	-5287000
4210.3	2605000	-5821000	225400000	-38690000	157000000	-5548000
4227.4	2610000	-5868000	227400000	-38870000	158700000	-5657000
4254	2527000	-6076000	230500000	-39230000	161500000	-5824000
4297.8	2732000	-6242000	235500000	-39910000	166400000	-6098000
4341.6	2850000	-6381000	240500000	-40200000	171200000	-6373000
4385.5	8.434	-33.25	209900	-210100	274900	-267000

**NLS2 COMPOSITE LINE BODY LOADS W/O STME OUT
BUILD-UP AND SHUT-DOWN**

X-Station (in)	NX+ (lbs/in)		NX- (lbs/in)		NX- (lbs/in)		PEQ+ (lbs)		PEQ- (lbs)		PEQ- (lbs)	
	Maximum	Minimum	Maximum	Minimum	Maximum	Minimum	Maximum	Minimum	Maximum	Minimum	Maximum	Minimum
1306.1	0	0	0	0	0	0	0	0	0	0	0	0
1395.1	4.679	-1.208	4.679	-1.208	1029	-265.6	1029	-265.6	1029	-265.6	1029	-265.6
1444.9	7.396	-1.905	7.396	-1.905	2788	-718.3	2788	-718.3	2788	-718.3	2788	-718.3
1494.6	12.38	-3.174	12.38	-3.174	6225	-1595	6225	-1595	6225	-1595	6225	-1595
1544.4	13.53	-3.445	13.53	-3.445	8499	-2165	8499	-2165	8499	-2165	8499	-2165
1624.4	17.06	-4.29	17.06	-4.29	10720	-2696	10720	-2696	10720	-2696	10720	-2696
1704.4	20.48	-5.059	20.48	-5.059	12870	-3179	12870	-3179	12870	-3179	12870	-3179
1784.4	23.77	-5.737	23.77	-5.737	14930	-3605	14930	-3605	14930	-3605	14930	-3605
1864.4	26.9	-6.31	26.9	-6.31	16900	-3965	16900	-3965	16900	-3965	16900	-3965
1944.4	29.87	-6.767	29.87	-6.767	18770	-4252	18770	-4252	18770	-4252	18770	-4252
2024.4	32.66	-7.097	32.66	-7.097	20520	-4459	20520	-4459	20520	-4459	20520	-4459
2104.4	35.25	-7.29	35.25	-7.29	22150	-4580	22150	-4580	22150	-4580	22150	-4580
2184.4	37.64	-7.339	37.64	-7.339	23650	-4611	23650	-4611	23650	-4611	23650	-4611
2264.4	39.81	-7.238	39.81	-7.238	25020	-4548	25020	-4548	25020	-4548	25020	-4548
2284.8	345	-47.38	251.6	-99.9	216800	-29770	216800	-29770	158100	-62770	158100	-62770
2347.8	246.3	-57.67	246.3	-57.67	185200	-43370	185200	-43370	185200	-43370	185200	-43370
2410.8	212.9	-47.76	212.9	-47.76	186500	-41830	186500	-41830	186500	-41830	186500	-41830
2459.2	248.5	13.5	248.5	13.5	241300	13110	241300	13110	241300	13110	241300	13110
2471.1	324.4	42.81	324.4	42.81	322700	42580	322700	42580	322700	42580	322700	42580
2569.8	370.4	73.65	370.4	73.65	385200	76590	385200	76590	385200	76590	385200	76590
2664.1	421.8	133	421.8	133	438600	138300	438600	138300	438600	138300	438600	138300
2758.5	480.7	220.8	480.7	220.8	499800	229600	499800	229600	499800	229600	499800	229600
2852.8	548	325.6	548	325.6	569800	338600	569800	338600	569800	338600	569800	338600
2963.4	611.3	397.9	611.3	397.9	635700	413700	635700	413700	635700	413700	635700	413700
2985.7	1652	1333	1652	1333	1718000	1387000	1718000	1387000	1718000	1387000	1718000	1387000
3012.5	1663	1343	1663	1343	1730000	1396000	1730000	1396000	1730000	1396000	1730000	1396000
3123.1	1667	1355	1667	1355	1733000	1409000	1733000	1409000	1733000	1409000	1733000	1409000
3240	1661	1362	1661	1362	1727000	1416000	1727000	1416000	1727000	1416000	1727000	1416000
3356.9	1652	1368	1652	1368	1718000	1423000	1718000	1423000	1718000	1423000	1718000	1423000
3473.7	1647	1375	1647	1375	1713000	1430000	1713000	1430000	1713000	1430000	1713000	1430000
3590.6	1656	1383	1656	1383	1722000	1438000	1722000	1438000	1722000	1438000	1722000	1438000
3707.4	1669	1390	1669	1390	1736000	1446000	1736000	1446000	1736000	1446000	1736000	1446000
3824.3	1678	1398	1678	1398	1745000	1453000	1745000	1453000	1745000	1453000	1745000	1453000
3941.1	1684	1404	1684	1404	1751000	1460000	1751000	1460000	1751000	1460000	1751000	1460000
4058	1686	1412	1686	1412	1753000	1468000	1753000	1468000	1753000	1468000	1753000	1468000
4090.3	1688	1422	1688	1422	1755000	1478000	1755000	1478000	1755000	1478000	1755000	1478000
4122.6	1690	1433	1690	1433	1757000	1490000	1757000	1490000	1757000	1490000	1757000	1490000
4166.6	1950	1670	1950	1670	2028000	1737000	2028000	1737000	2025000	1728000	2025000	1728000
4210.3	1953	1677	1953	1677	2031000	1744000	2031000	1744000	2030000	1744000	2030000	1744000
4227.4	1954	1680	1954	1680	2032000	1747000	2032000	1747000	2032000	1747000	2032000	1747000
4254	1963	1695	1963	1695	2042000	1763000	2042000	1763000	2041000	1762000	2041000	1762000
4297.8	1971	1708	1971	1708	2049000	1776000	2049000	1776000	2047000	1775000	2047000	1775000
4341.6	1969	1692	1969	1692	2047000	1759000	2047000	1759000	2046000	1752000	2046000	1752000
4385.5	2870	0.2145	-0.214	-2870	2985000	223.1	2985000	223.1	-222.5	-2985000	-222.5	-2985000

**NLS2 BUILDUP/SHUTDOWN W/O STME OUT
COMPOSITE AXIAL SHEAR LOADS VS X-STATION**

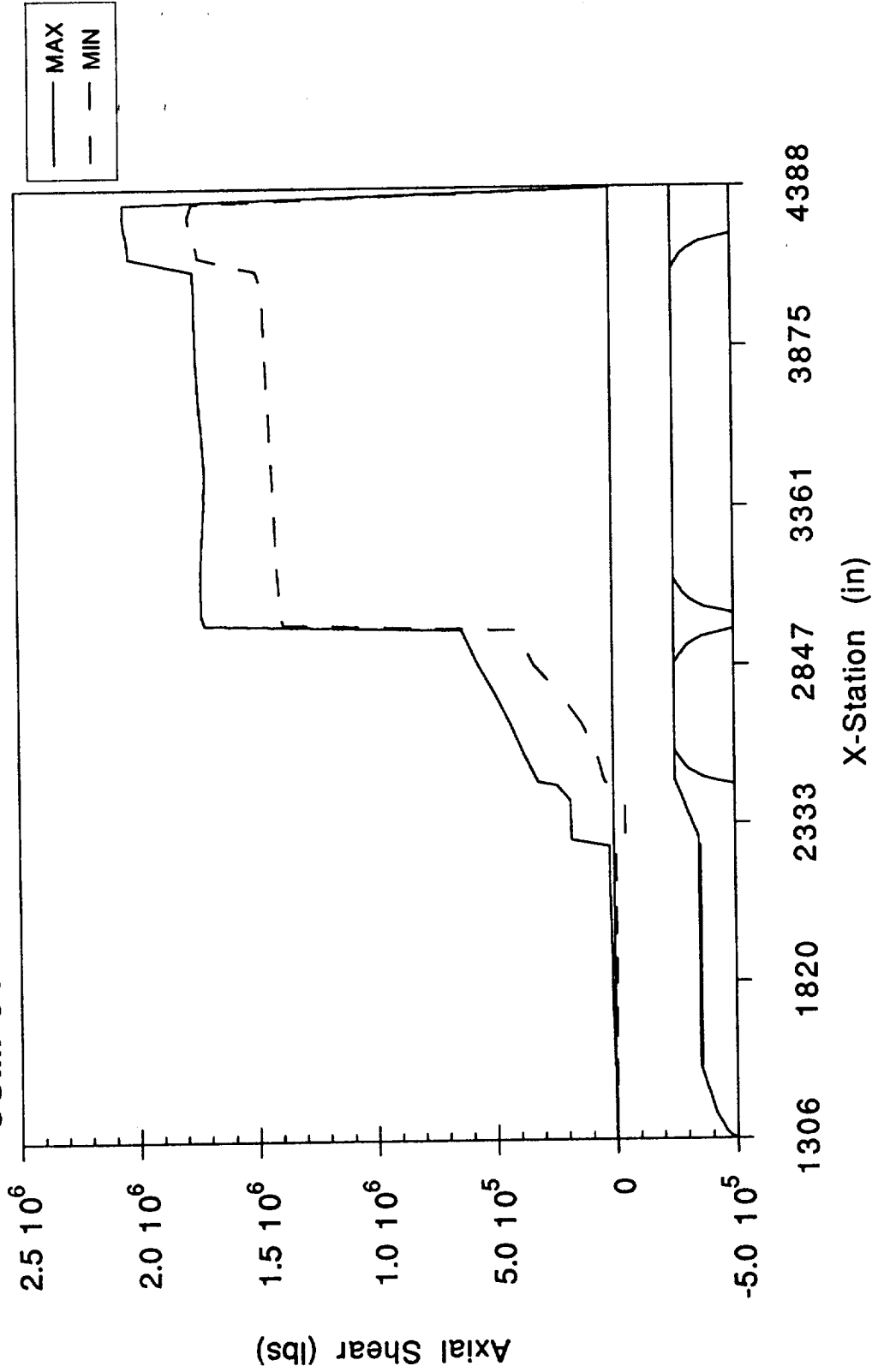

3-3

NLS2 BUILDUP/SHUTDOWN W/O STME OUT COMPOSITE Y-DIR SHEAR LOADS VS X-STATION

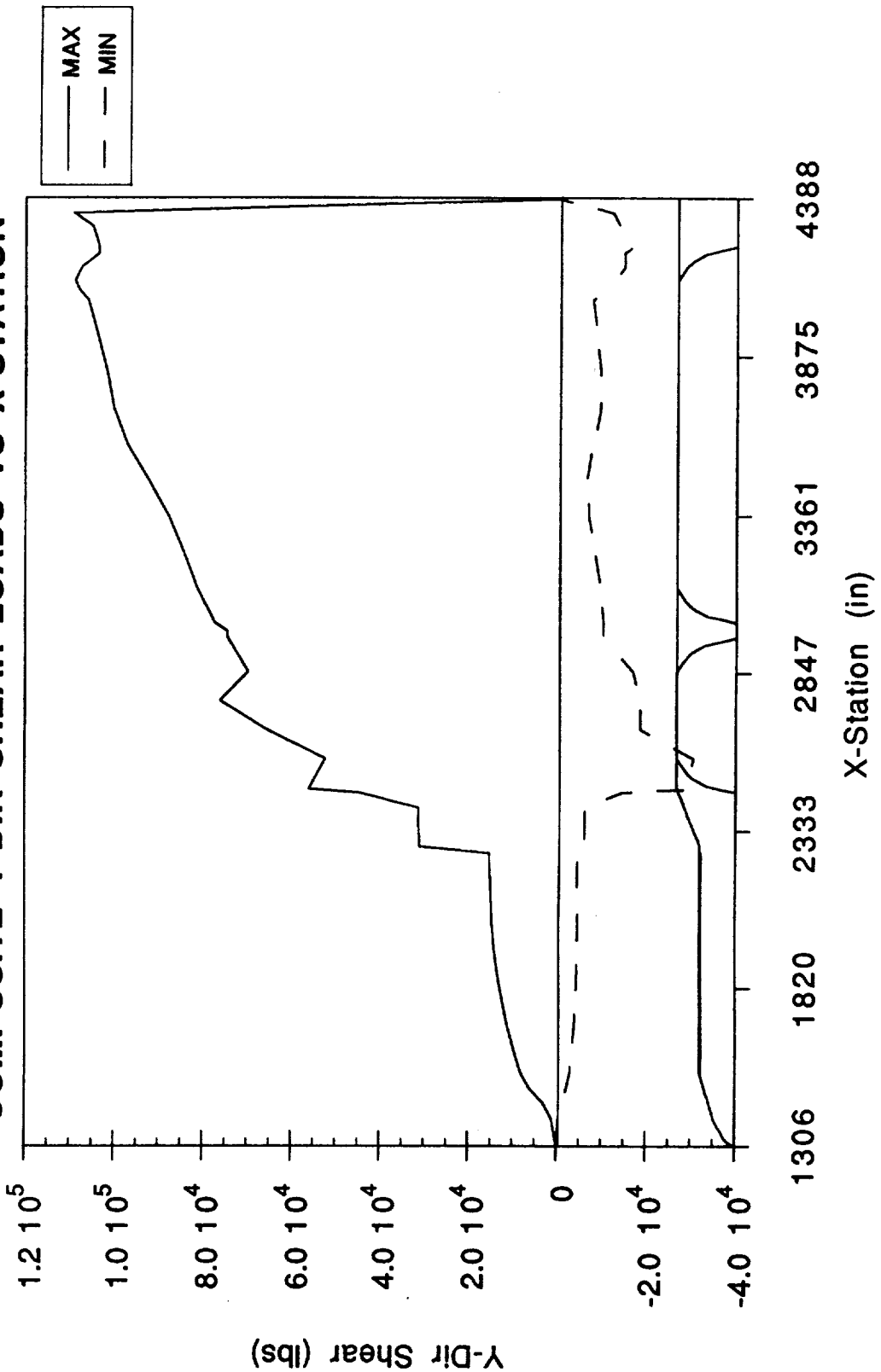

(

(

(

**NLS2 BUILDUP/SHUTDOWN W/O STME OUT
COMPOSITE Z-DIR SHEAR LOADS VS X-STATION**

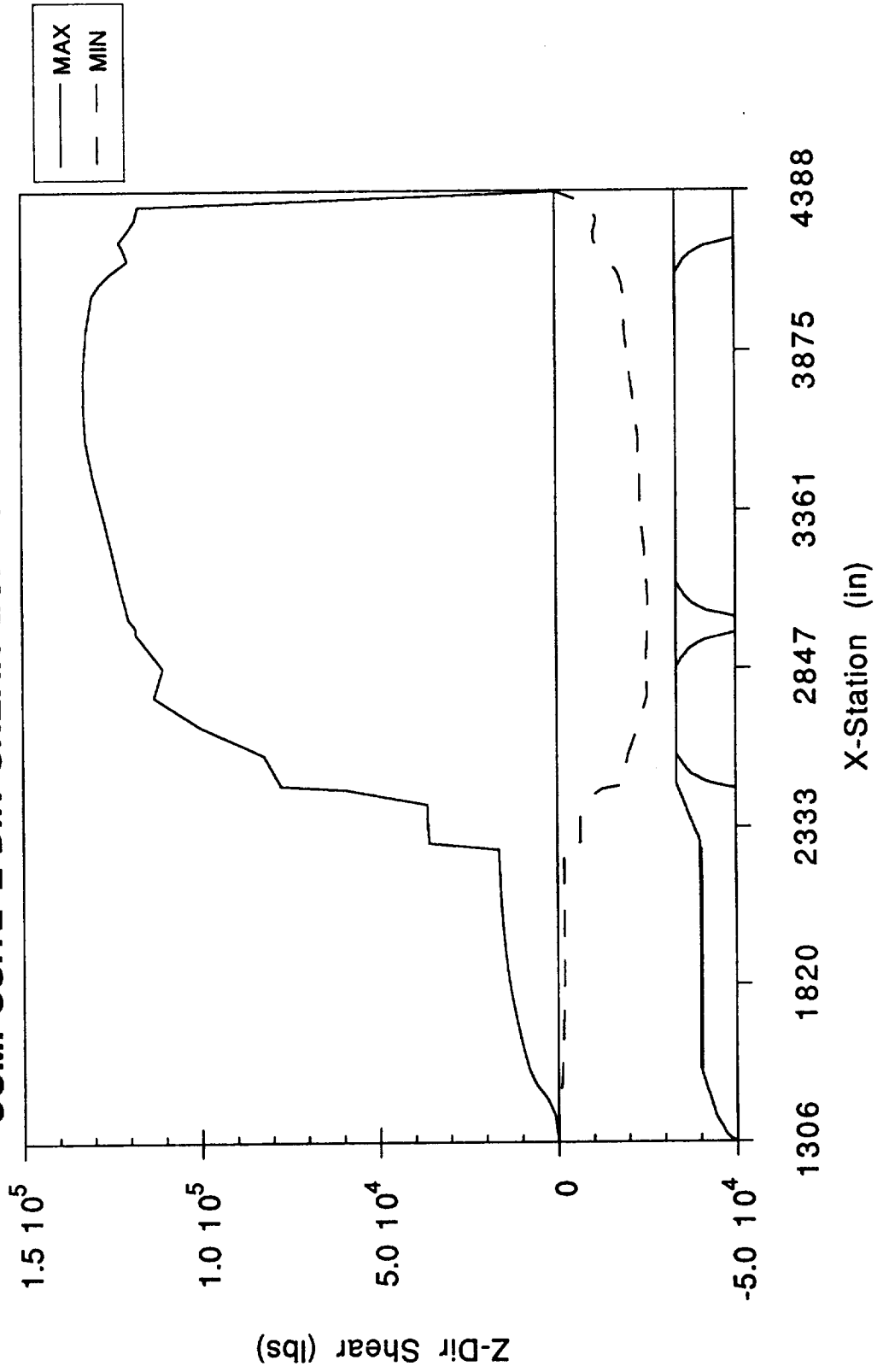

NLS2 BUILDUP/SHUTDOWN W/O STME OUT COMPOSITE X-DIR TORSION VS X-STATION

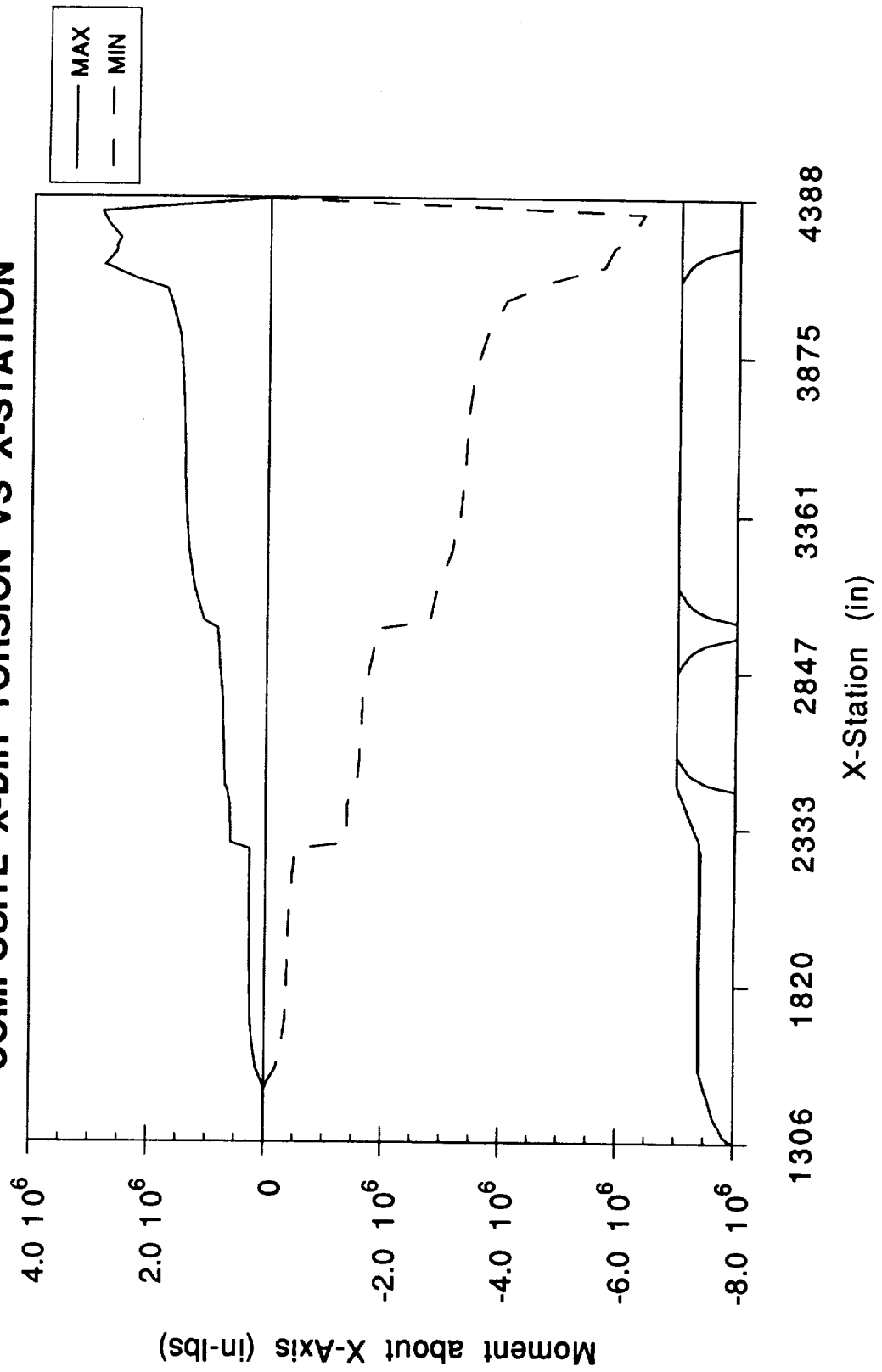

(((

**NLS2 BUILDUP/SHUTDOWN W/O STME OUT
COMPOSITE Y-DIR MOMENT VS X-STATION**

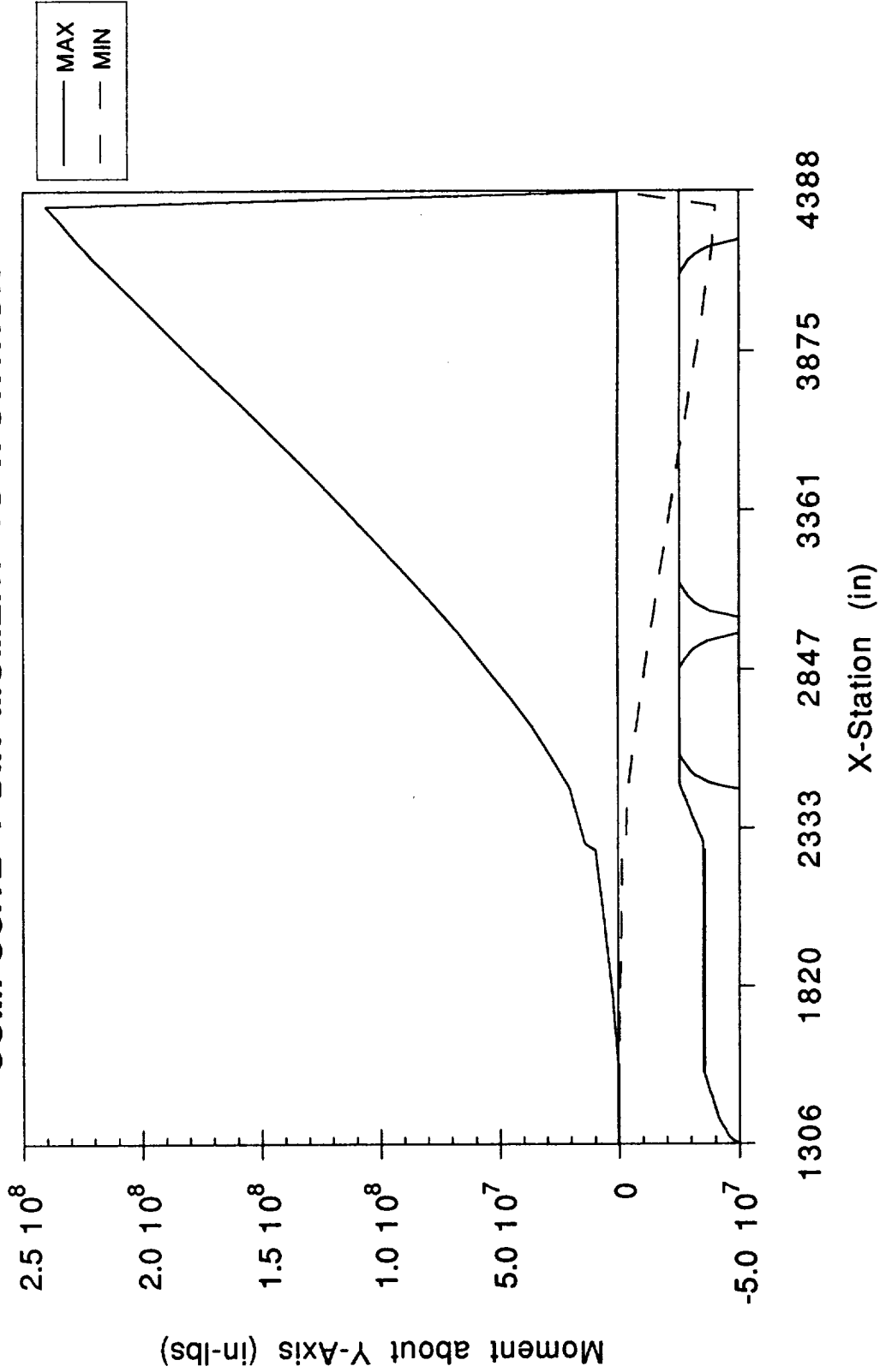

NLS2 BUILDUP/SHUTDOWN W/O STME OUT COMPOSITE Z-DIR MOMENT VS X-STATION

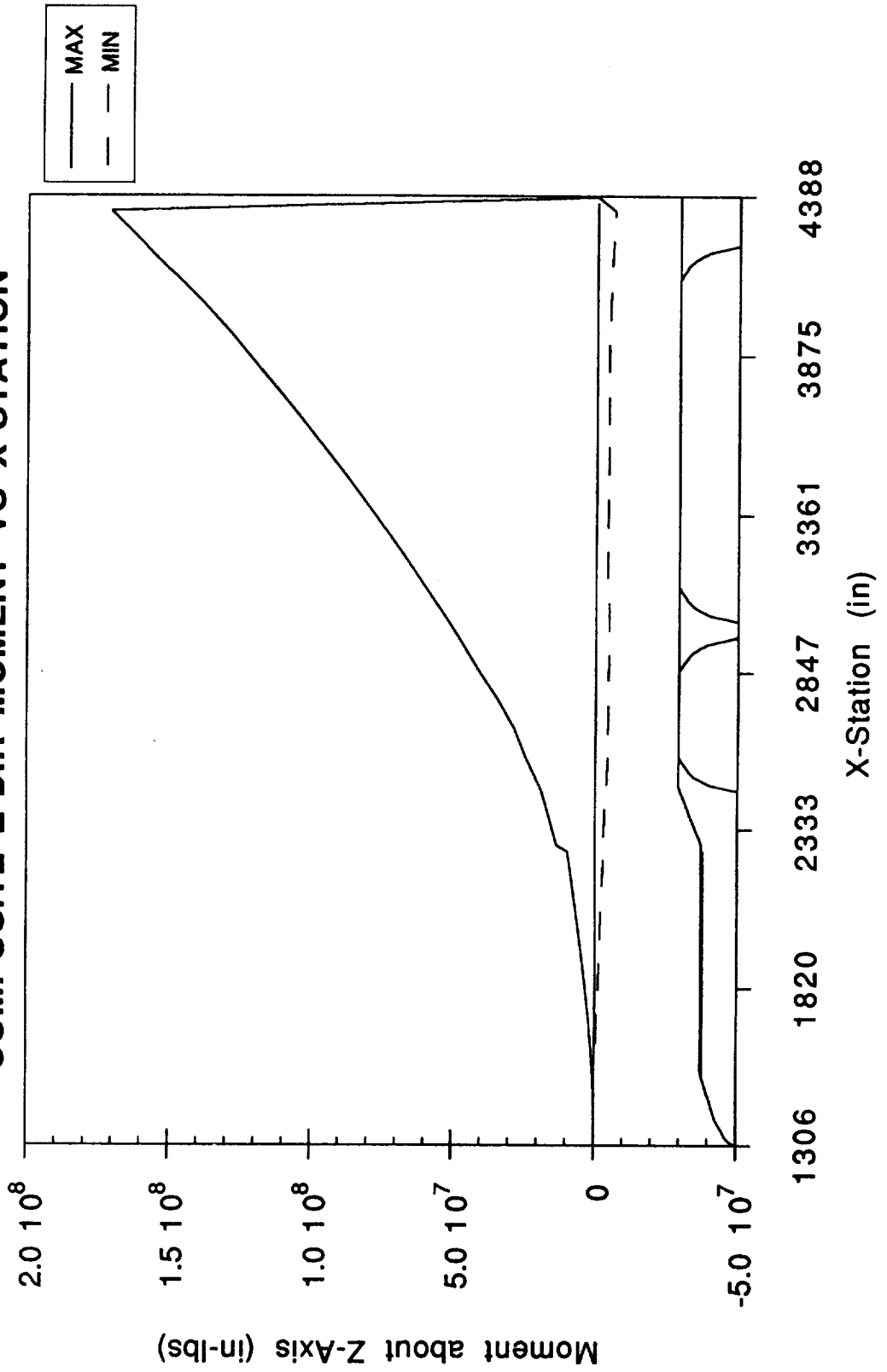

(((

**NLS2 BUILDUP/SHUTDOWN W/O STME OUT
COMPOSITE NX+ LOADS VS X-STATION**

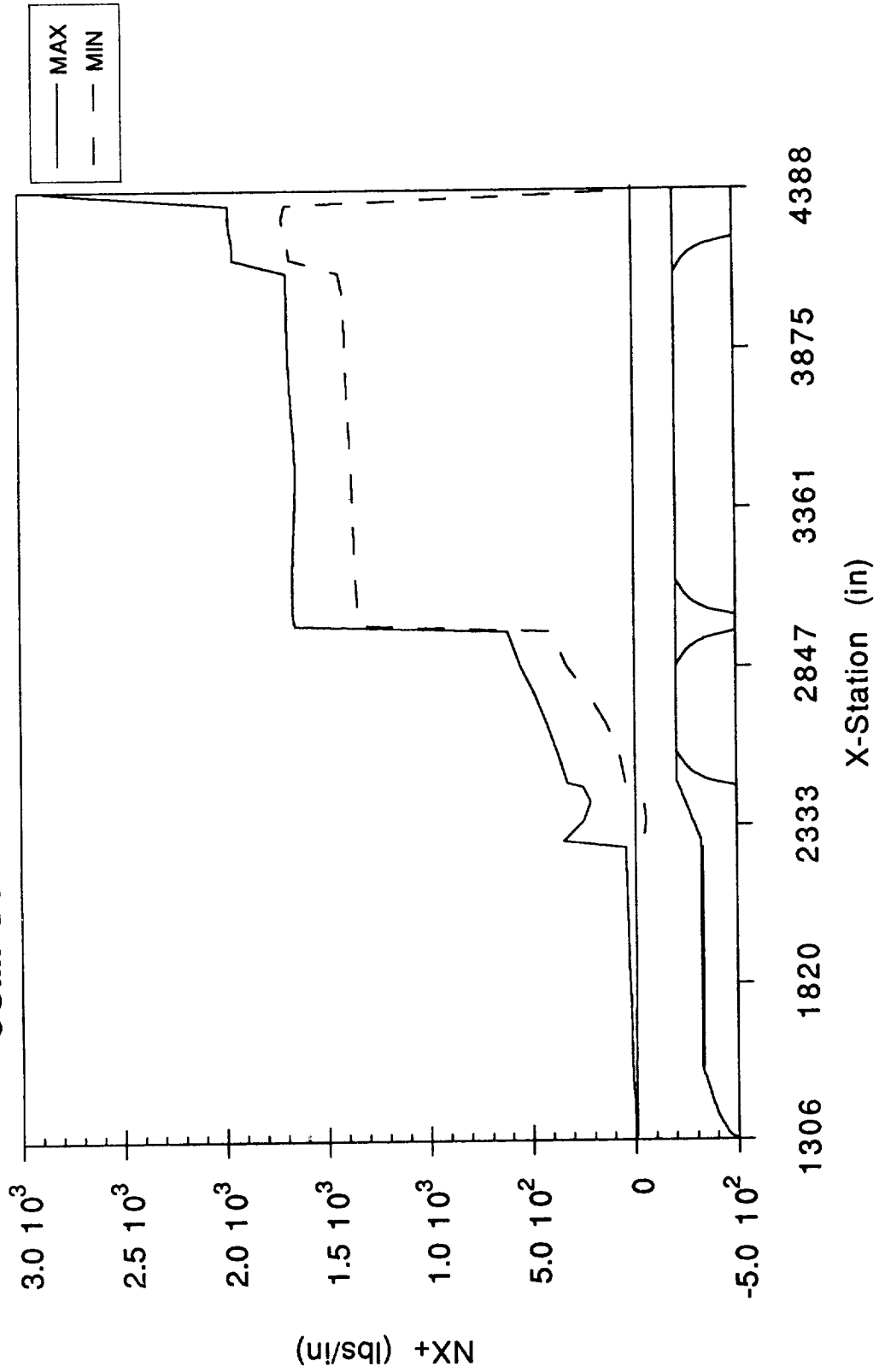

**NLS2 BUILDUP/SHUTDOWN W/O STME OUT
COMPOSITE NX- LOADS VS X-STATION**

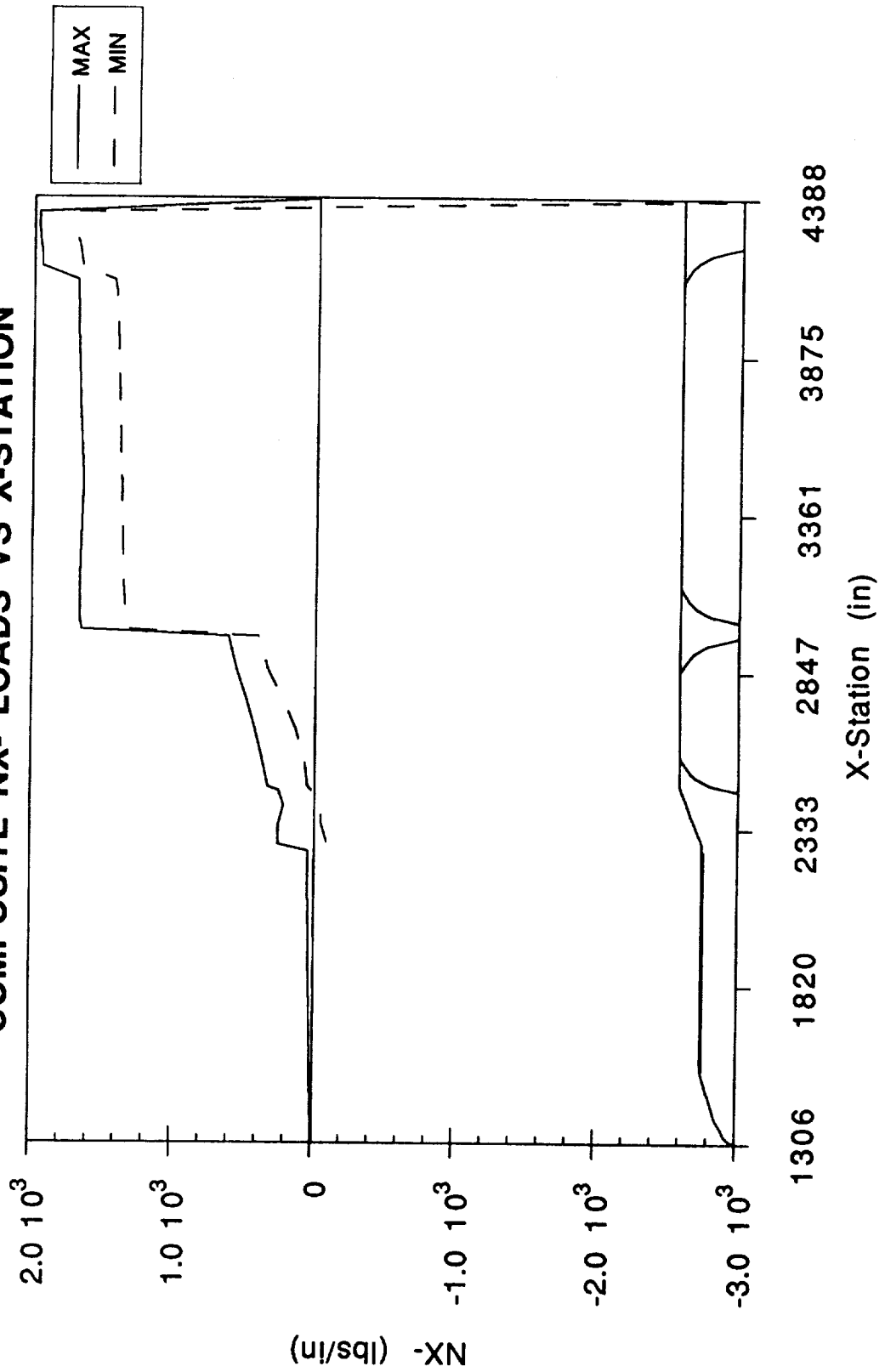

NLS 1
LIFTOFF DATA

1

2

3

NLS1 WITH STME OUT LIFTOFF PAD FORCES (KIPS)

PAD NUMBER	MAXIMUM			MINIMUM		
	X-DIR	Y-DIR	Z-DIR	X-DIR	Y-DIR	Z-DIR
M1	4.9	95.4	2.4	-495	-7.4	-154.8
M2	7.4	19.9	3.4	-833.3	-126.8	-276.9
M3	5.4	86.4	160.7	-511.1	0	-6.33
M4	6.4	35.2	271	-817.8	-111.4	-0.3
M5	3.5	16.6	2	-556.4	-99.8	-177.6
M6	7.5	112.8	4.3	-699.9	-9	-230.9
M7	5.2	10.2	183.4	-571.9	-92.5	-6.7
M8	6.5	97.9	224.7	-683.3	-13.5	-1.3

NLS1 WITH OUT STME OUT LIFTOFF PAD FORCES (KIPS)

PAD NUMBER	MAXIMUM			MINIMUM		
	X-DIR	Y-DIR	Z-DIR	X-DIR	Y-DIR	Z-DIR
M1	4.9	95.4	2.4	-495	-7.4	-154.8
M2	7.4	19.9	3.4	-833.3	-126.8	-276.9
M3	5.4	86.4	160.7	-511.1	0	-6.3
M4	6.4	35.2	271	-817.8	-111.4	-0.3
M5	3.5	16.6	2	-556.4	-99.8	-177.6
M6	7.5	112.8	4.3	-699.9	-9	-230.9
M7	5.2	10.2	183.4	-571.9	-92.5	-6.7
M8	4	97.9	224.7	-683.3	-13.5	-1.3

NLS1 Liftoff Accelerations (G's)

	W/STME Out		W/O STME Out	
	Maximum	Minimum	Maximum	Minimum
Node 7 Payload 1 30K X-Dir	1.819	-0.916	1.819	-0.916
Node 7 Payload 1 30K Y-Dir	0.879	-0.6014	0.879	-0.6014
Node 7 Payload 1 30K Z-Dir	0.9074	-0.927	0.902	-0.927
Node 90 Payload 2 40K X-Dir	1.6023	-0.687	1.6023	-0.687
Node 90 Payload 2 40K Y-Dir	0.5394	-0.333	0.5394	-0.333
Node 90 Payload 2 40K Z-Dir	0.6216	-0.5757	0.6216	-0.5757
Node 12 Payload 3 30K X-Dir	1.6855	-0.49	1.6855	-0.49
Node 12 Payload 3 30K Y-Dir	0.3054	-0.2446	0.3054	-0.2446
Node 12 Payload 3 30K Z-Dir	0.495	-0.4656	0.495	-0.4656
Node 80 LO2 Slosh X-Dir	1.2051	-0.23	1.2051	-0.23
Node 81 LH2 Slosh X-Dir	1.5274	-0.59	1.5274	-0.59
Node 45 FPM X-Dir	1.8837	-0.96	1.8837	-0.96
Node 45 FPM Y-Dir	1.391	-0.9517	1.391	-0.9517
Node 45 FPM Z-Dir	1.445	-1.679	1.434	-1.679
Node 46 CTV X-Dir	1.8615	-0.379	1.8615	-0.379
Node 46 CTV Y-Dir	0.2237	-0.1194	0.2237	-0.1194
Node 46 CTV Z-Dir	0.3612	-0.3424	0.3599	-0.3424

NLS1 Liftoff Core Interface Loads (kips)

Location	With STME Out		Without STME Out		Allowable (Max)	Allowable (Min)
	Maximum	Minimum	Maximum	Minimum		
Fwd Attach +y	94.43	-1163	94.43	-1163	156	-1725
Fwd Attach +y	118.9	-228.7	118.9	-228.7	86	-219
Fwd Attach +y	18.14	-16.64	18.14	-16.48	204	-172
Fwd Attach -y	237.8	-1129	237.8	-1129		
Fwd Attach -y	210.6	-120.8	210.6	-120.8		
Fwd Attach -y	16.21	-14.59	16.21	-14.32		
Aft Attach +y	111.4	-80.37	111.4	-80.37		
Aft Attach +y	48.3	-38.86	45.71	-38.86		
Aft Attach +y	115.1	-65.72	113.6	-65.72		
Aft Attach +y	6.073	-11.22	6.073	-11.09		
Aft Attach -y	79.63	-113.3	79.63	-113.3		
Aft Attach -y	48.62	-38.75	48.62	-38.75		
Aft Attach -y	64.18	-121.7	64.18	-120.5		
Aft Attach -y	5.933	-11.82	5.933	-11.76		

*upper aft attach

**lower aft attach

NLS1 COMPOSITE SHEAR BODY LOADS W/STME OUT (LBS)

LIFTOFF

X-Station (in)	X-Dir.		Y-Dir.		Z-Dir.	
	Maximum	Minimum	Maximum	Minimum	Maximum	Minimum
1066.06	92.67	7.684	39.73	-26.85	45.39	-39.46
1110.6	1379	114.4	543.9	-380.3	631.3	-554.5
1155.1	3720	308.7	1379	-990.6	1630	-1436
1229.75	8234	684.7	2779	-2071	3353	-2968
1304.4	31340	2615	9485	-7247	11430	-10220
1411	38670	3237	11220	-8649	13480	-12100
1518	165500	14190	35280	-29890	42320	-38050
1625	170900	14720	36240	-30920	43460	-39010
1732	174900	15190	36930	-31680	44150	-39530
1784.4	251900	25850	51220	-46200	56480	-48240
1839	254700	26360	51740	-46630	56810	-48940
1946	256900	27020	52090	-46760	56780	-49300
2050.8	287300	20920	56230	-48150	51740	-50820
2160	289500	21190	56570	-48350	51350	-50680
2264.4	292400	22590	56790	-48440	50930	-50400
2284.8	336200	34310	58520	-48930	45530	-46120
2340.68	338600	35010	58590	-48950	45450	-45950
2396.57	341400	36020	58590	-48930	45340	-45770
2459.17	507600	101600	57290	-40110	63530	-77710
2473.8	676500	165300	68600	-56980	108700	-122400
2569.8	828500	214900	73290	-75220	132400	-136000
2664.13	942000	242500	79530	-90050	145400	-130700
2758.47	1009000	250200	90810	-114700	127300	-104900
2852.8	1044000	257200	101600	-132500	93670	-97750
2963.42	3219000	1303000	115000	-152400	51750	-69340
2990.67	1653000	-421100	29300	-70980	65460	-65470
3012.52	1677000	-410200	30400	-69500	59220	-59710
3123.15	1728000	-396600	31380	-68070	48870	-50170
3233.63	1776000	-386300	32690	-65990	37550	-42660
3337.35	1829000	-375300	34660	-63660	43530	-39440
3480.57	1880000	-364200	37450	-59610	50420	-48000
3623.8	1921000	-353900	40480	-55030	57110	-60160
3747.4	1946000	-344600	43040	-53310	62460	-71200
3871	1955000	-337200	44580	-52100	65780	-72880
3964.5	1948000	-330400	45130	-51100	67630	-71810
4054	1915000	-323400	24990	-39520	64760	-60870
4118.65	1858000	-315900	23500	-57360	72440	-55010
4122.65	1799000	-308500	24660	-76380	87540	-49590
4233.27	1851000	-90230	22640	-81800	94350	-41800
4309.4	1317000	-61010	17350	-71000	84760	-29920
4385.5	0.02736	-81.7	0.09784	-116.7	88.08	-0.2868

NLS1 COMPOSITE MOMENT BODY LOADS W/STME OUT (IN-LBS)

LIFTOFF

X-Station (in)	X-Dir. Maximum	X-Dir. Minimum	Y-Dir. Maximum	Y-Dir. Minimum	Z-Dir. Maximum	Z-Dir. Minimum
1066.06	24950	-24730	0.01646	-0.02552	0.06142	-0.0006733
1110.6	30750	-29320	2022	-1757	1770	-1196
1155.1	34150	-31480	30100	-26430	25970	-18120
1229.75	35200	-31360	151800	-133600	128900	-92070
1304.4	39180	-34620	578300	-510600	477800	-357600
1411	47870	-39720	1796000	-1600000	1489000	-1130000
1518	109200	-103700	5166000	-4588000	4331000	-3051000
1625	115500	-113300	9557000	-8635000	7920000	-6177000
1732	119900	-121100	14120000	-12800000	11800000	-9400000
1784.4	147100	-172700	17860000	-16290000	14420000	-11810000
1839	149700	-178300	20840000	-18860000	17200000	-14240000
1946	150400	-181300	26790000	-23910000	22700000	-19130000
2050.8	162700	-189100	33440000	-29280000	28610000	-24500000
2160	165700	-192600	38940000	-33630000	34690000	-29440000
2264.4	167900	-194800	44180000	-37780000	40510000	-34140000
2284.8	198100	-222400	44780000	-37270000	42780000	-35220000
2340.68	204700	-227500	47020000	-38980000	45860000	-37600000
2396.57	216200	-232300	49380000	-40660000	48950000	-39970000
2459.17	253600	-255900	52020000	-43070000	52400000	-42630000
2473.8	278800	-282700	52010000	-43190000	52980000	-42980000
2569.8	301200	-312200	48430000	-40650000	55230000	-44880000
2664.13	320500	-339900	42970000	-35270000	55710000	-45250000
2758.47	336700	-364900	37900000	-38170000	57680000	-43630000
2852.8	367900	-422600	41980000	-46200000	60250000	-39970000
2963.42	389300	-473100	50750000	-51690000	65620000	-49700000
2990.67	696900	-1231000	51310000	-51250000	63480000	-42200000
3012.52	715600	-1242000	51380000	-51260000	62090000	-41560000
3123.15	699600	-1246000	50820000	-50300000	55160000	-38200000
3233.63	677000	-1246000	49130000	-48140000	49010000	-34730000
3337.35	643600	-1241000	46540000	-45070000	44000000	-31340000
3480.57	599900	-1233000	41670000	-39430000	37250000	-26380000
3623.8	607000	-1221000	35650000	-35690000	30360000	-21010000
3747.4	654600	-1208000	29660000	-32280000	26320000	-17670000
3871	693700	-1197000	23050000	-30510000	28680000	-13740000
3964.5	722700	-1188000	17750000	-31880000	29180000	-10140000
4054	459600	-539900	15610000	-33650000	27890000	-7952000
4118.65	431800	-520500	11750000	-30610000	25380000	-6554000
4122.65	408800	-501200	11530000	-30340000	25150000	-6462000
4233.27	381200	-470300	6060000	-21210000	16700000	-3767000
4309.4	373900	-461300	3106000	-14340000	10470000	-2065000
4385.5	349.9	-0.4949	187900	-710.1	352.6	-439100

NLS1 COMPOSITE LINE BODY LOADS W/STME OUT

LIFTOFF

X-Station (in)	NX+ (lbs/in)		NX- (lbs/in)		PEQ+ (lbs)		PEQ- (lbs)	
	Maximum	Minimum	Maximum	Minimum	Maximum	Minimum	Maximum	Minimum
1066.06	0	0	0	0	0	0	0	0
1110.6	6.272	0.5201	6.272	0.5201	6.272	0.5201	1379	114.4
1155.1	9.869	0.8188	9.869	0.8188	9.869	0.8188	3720	308.7
1229.75	16.38	1.362	16.38	1.362	16.38	1.362	8234	684.7
1304.4	51.05	4.169	49.5	2.828	49.5	2.828	31100	1777
1411	61.54	5.152	61.54	5.152	61.54	5.152	38670	3237
1518	307.9	22.63	260.1	6.425	260.1	6.425	163400	4037
1625	272	23.43	272	23.43	272	23.43	170900	14720
1732	278.3	24.18	278.3	24.18	278.3	24.18	174900	15190
1784.4	412.5	41.18	390.6	39.21	390.6	39.21	245400	24640
1839	405.4	41.95	405.4	41.95	405.4	41.95	254700	26360
1946	408.9	43.01	408.9	43.01	408.9	43.01	256900	27020
2050.8	460.6	35.53	454.5	30.87	454.5	30.87	285600	19390
2160	460.8	33.72	460.8	33.72	460.8	33.72	289500	21190
2264.4	465.4	35.95	465.4	35.95	465.4	35.95	292400	22590
2284.8	528	71.86	490.3	26.49	490.3	26.49	327700	17710
2340.68	435.1	44.99	435.1	44.99	435.1	44.99	338600	35010
2396.57	384.4	40.56	384.4	40.56	384.4	40.56	341400	36020
2459.17	502	100.4	502	100.4	502	100.4	507600	101600
2473.8	650.5	159	650.5	159	650.5	159	676500	165300
2569.8	796.7	206.6	796.7	206.6	796.7	206.6	828500	214900
2664.13	905.9	233.2	905.9	233.2	905.9	233.2	942000	242500
2758.47	970.4	240.6	970.4	240.6	970.4	240.6	1009000	250200
2852.8	1004	247.3	1004	247.3	1004	247.3	1044000	257200
2963.42	3096	1253	3096	1253	3096	1253	3219000	1303000
2990.67	2236	-404.9	1574	-982.7	1574	-982.7	1637000	-1022000
3012.52	1612	-394.5	1612	-394.5	1612	-394.5	1677000	-410200
3123.15	1662	-381.4	1662	-381.4	1662	-381.4	1728000	-396600
3233.63	1708	-371.5	1708	-371.5	1708	-371.5	1776000	-386300
3337.35	1759	-360.9	1759	-360.9	1759	-360.9	1829000	-375300
3480.57	1808	-350.2	1808	-350.2	1808	-350.2	1880000	-364200
3623.8	1847	-340.3	1847	-340.3	1847	-340.3	1921000	-353900
3747.4	1871	-331.4	1871	-331.4	1871	-331.4	1946000	-344600
3871	1880	-324.2	1880	-324.2	1880	-324.2	1955000	-337200
3964.5	1874	-317.7	1874	-317.7	1874	-317.7	1948000	-330400
4054	1842	-311	1842	-311	1842	-311	1915000	-323400
4118.65	1787	-303.8	1787	-303.8	1787	-303.8	1858000	-315900
4122.65	1730	-296.7	1730	-296.7	1730	-296.7	1799000	-308500
4233.27	1780	-86.77	1780	-86.77	1780	-86.77	1851000	-90230
4309.4	1266	-58.67	1266	-58.67	1266	-58.67	1317000	-61010
4385.5	113.8	-0.03237	-5.054E-06	-113.9	-5.054E-06	-113.9	-0.005256	-118500

NLS1 CORE LIFTOFF W/STME OUT COMPOSITE AXIAL SHEAR LOADS VS X-STATION

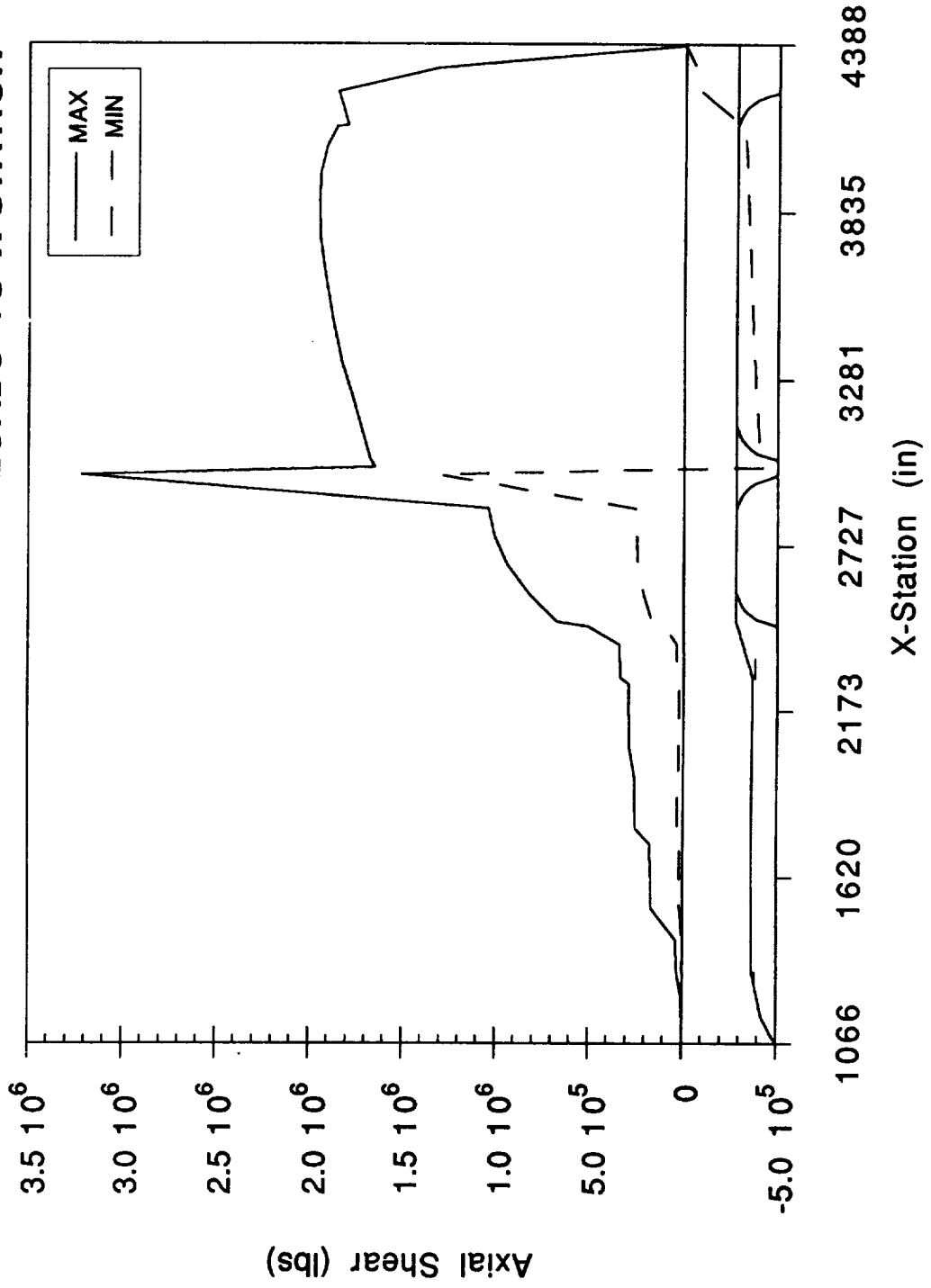

((

**NLS1 CORE LIFTOFF W/STME OUT
COMPOSITE Y-DIR SHEAR LOADS VS X-STATION**

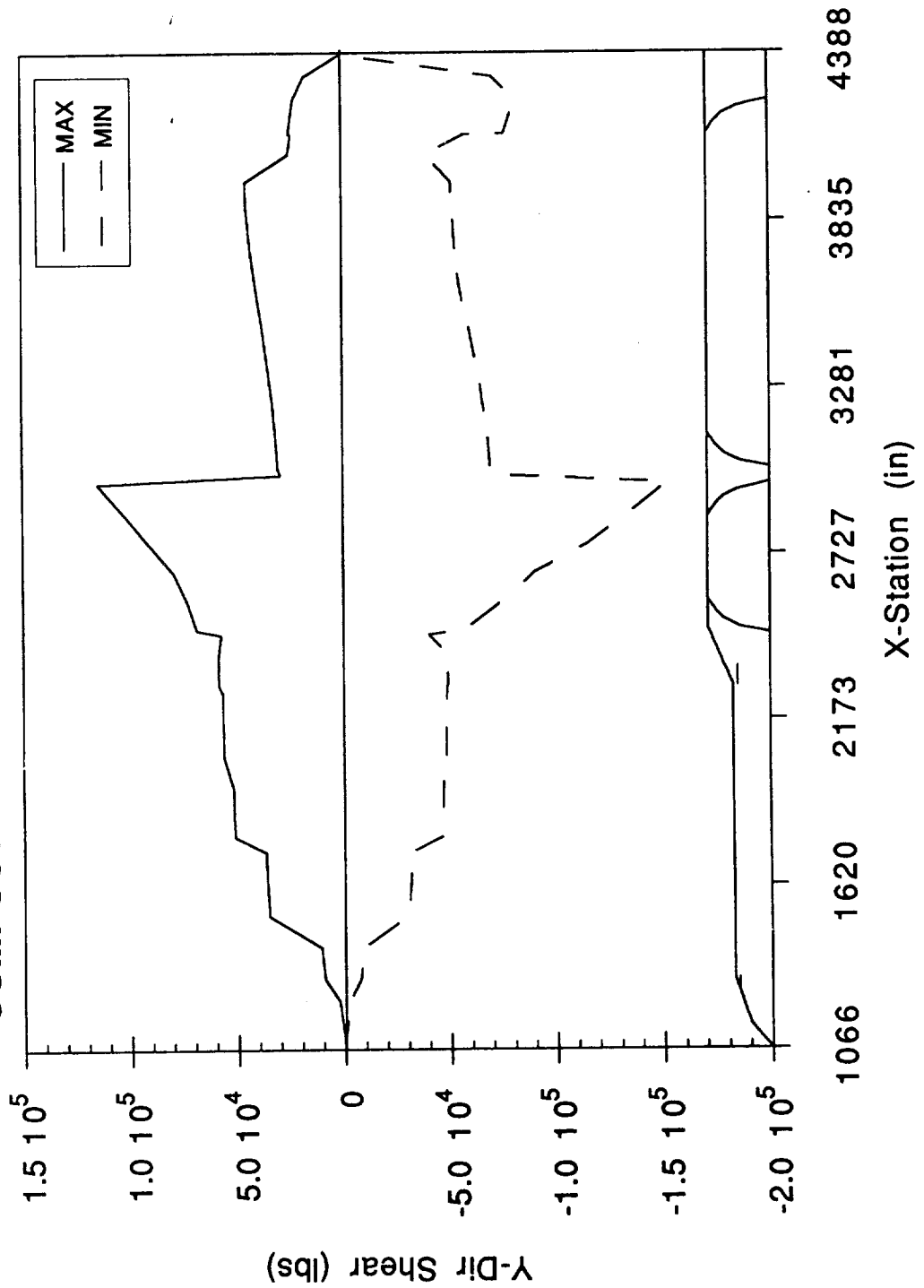

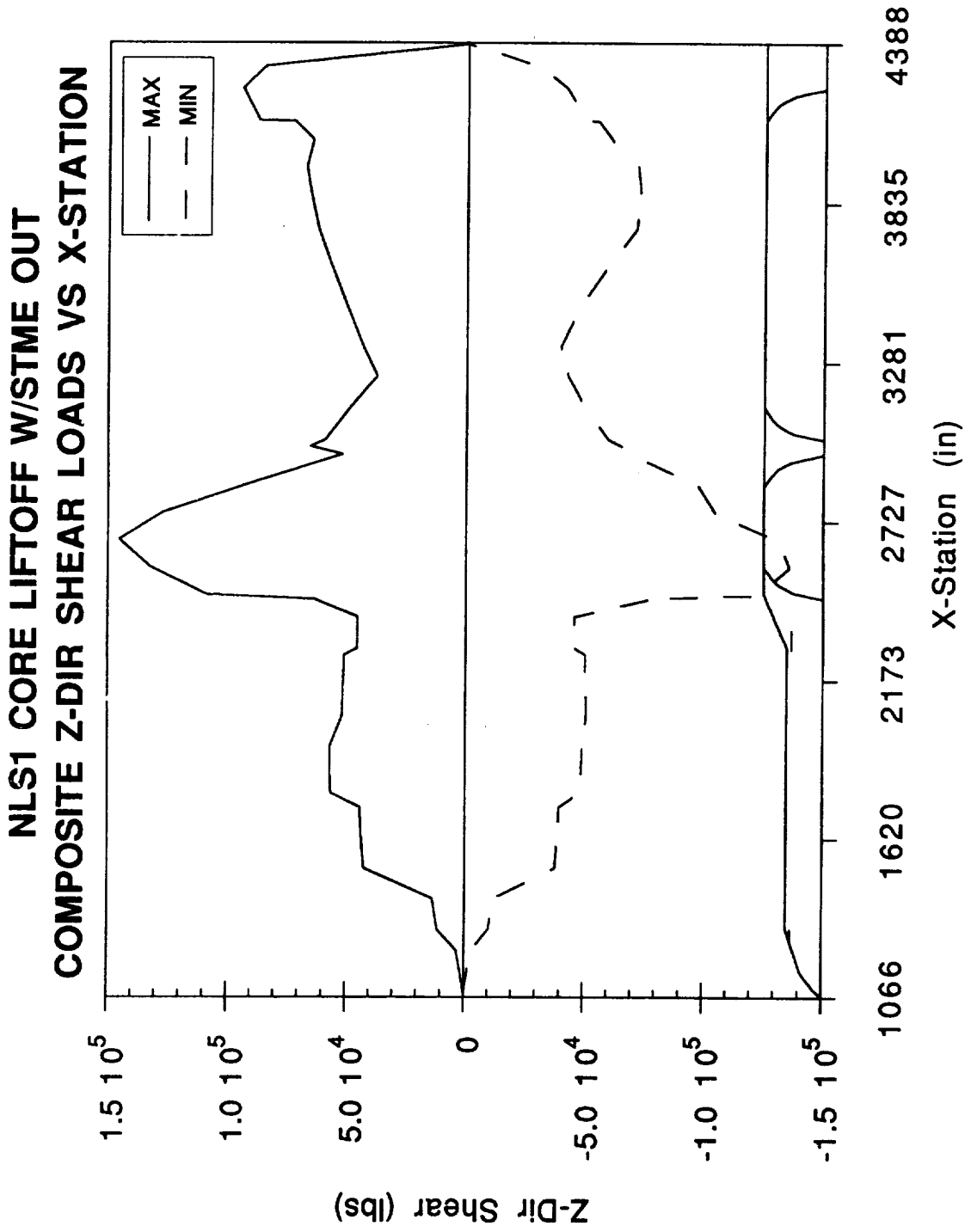

((

NLS1 CORE LIFTOFF W/STME OUT COMPOSITE X-DIR TORSION VS X-STATION

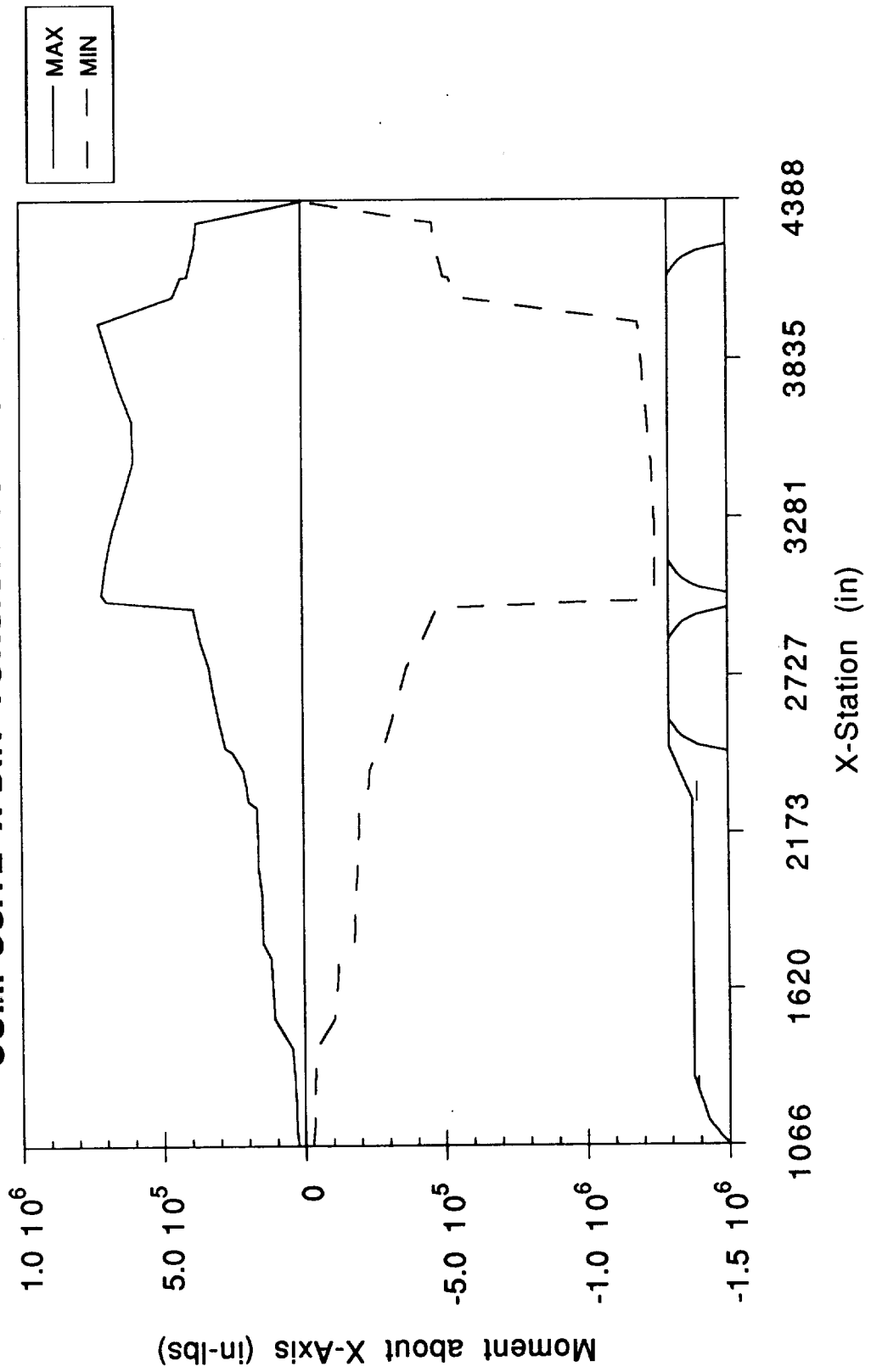

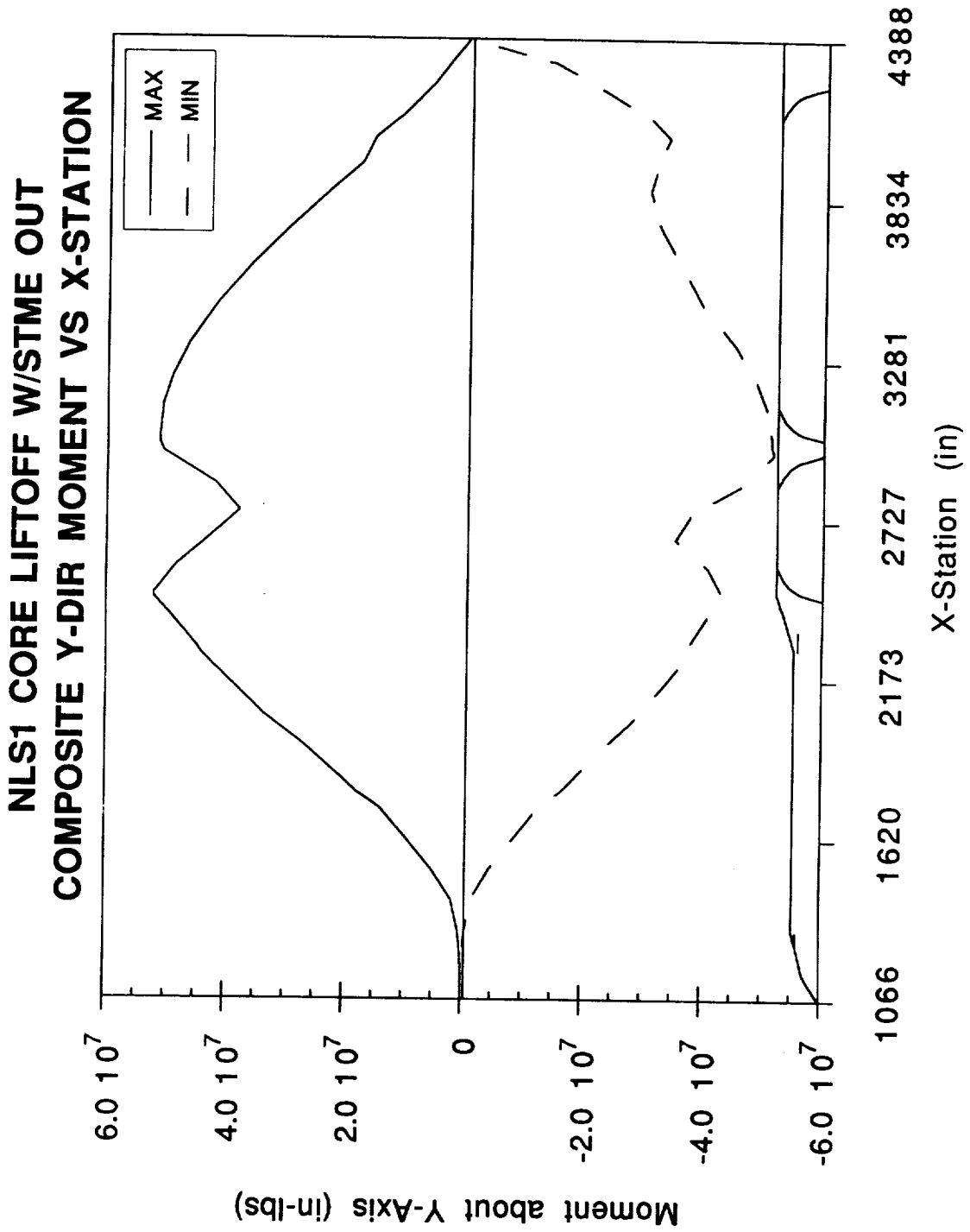

(((

NLS1 CORE LIFTOFF W/STME OUT COMPOSITE Z-DIR MOMENT VS X-STATION

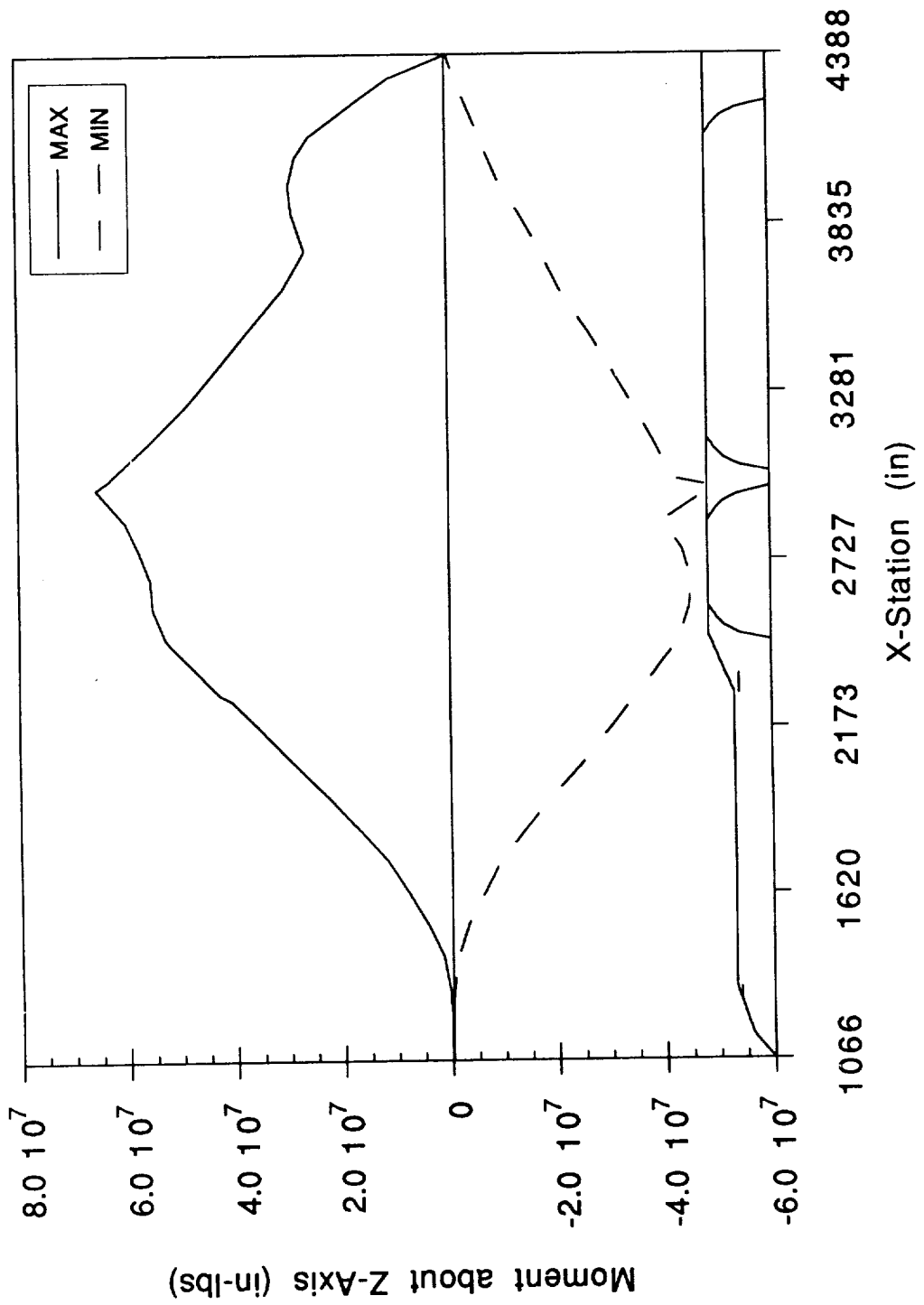

**NLS1 CORE LIFTOFF W/STME OUT
COMPOSITE NX+ LOADS VS X-STATION**

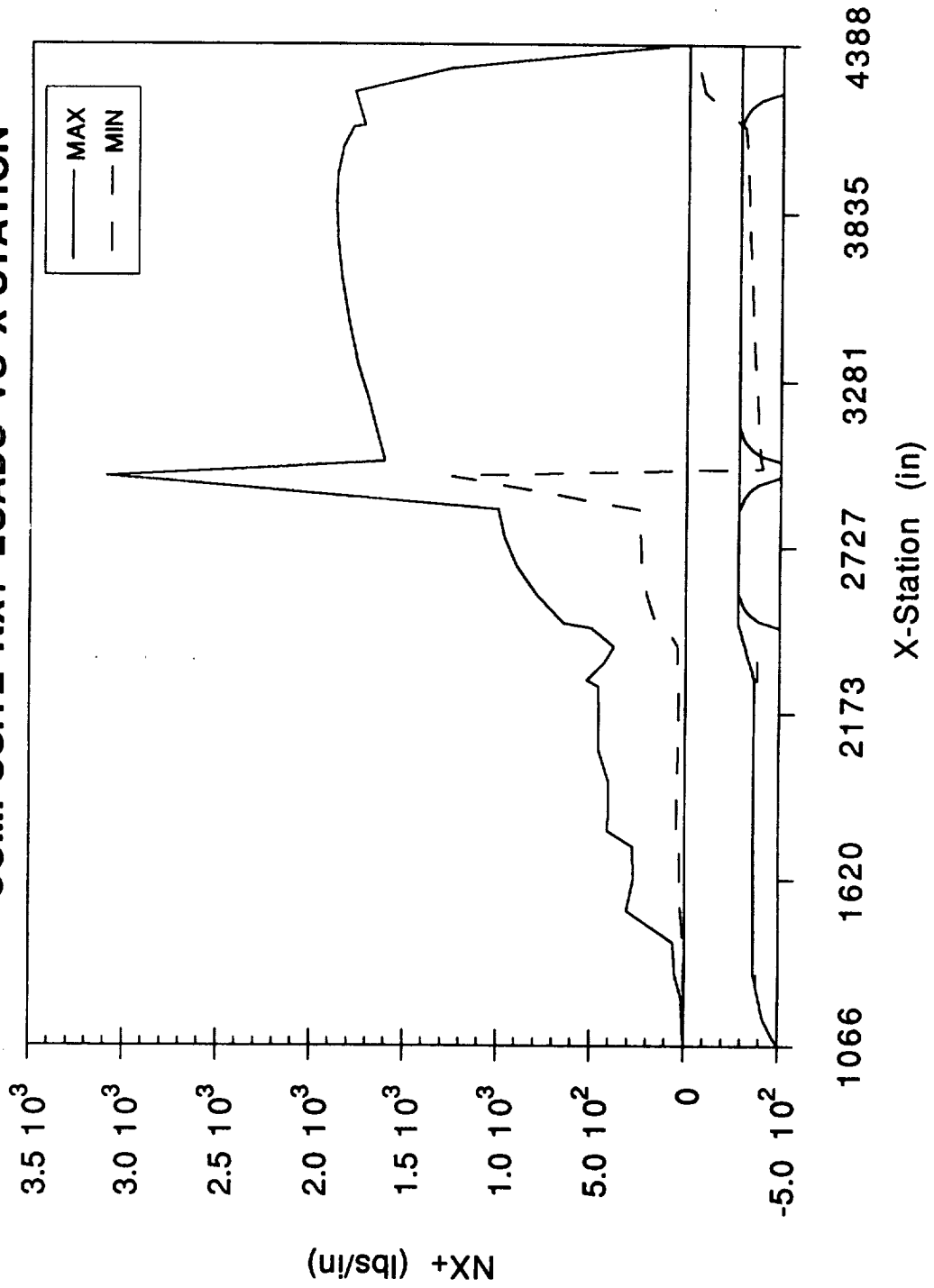

**NLS1 CORE LIFTOFF W/STME OUT
COMPOSITE NX- LOADS VS X-STATION**

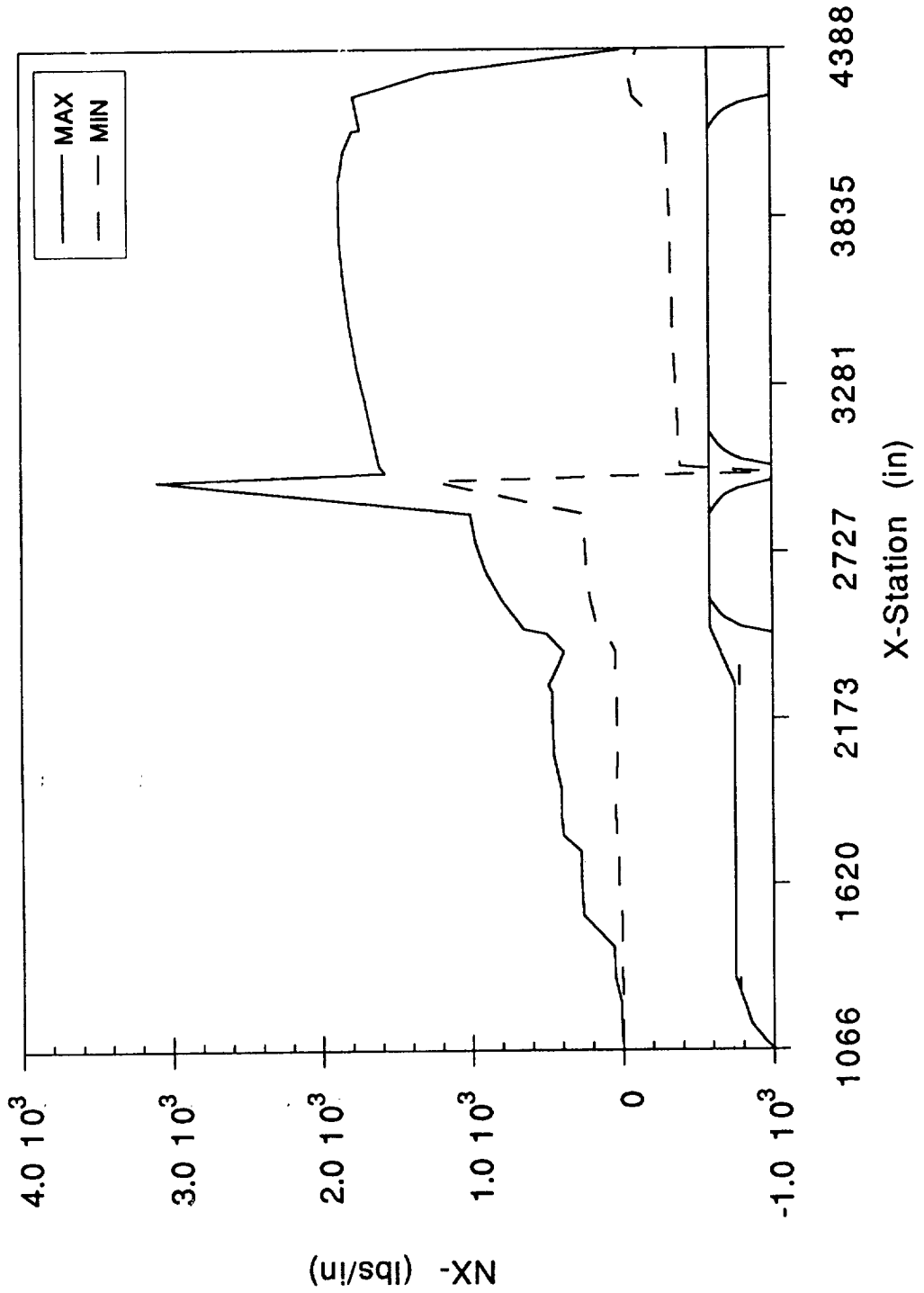

NLS1 COMPOSITE SHEAR BODY LOADS W/O STME OUT (LBS)

LIFTOFF

X-Station (in)	X-Dir.		X-Dir.		Y-Dir.		Y-Dir.		Z-Dir.	
	Maximum	Minimum	Maximum	Minimum	Maximum	Minimum	Maximum	Minimum	Maximum	Minimum
1066.06	92.67	7.684	39.73	-26.85	45.39	-39.46				
1110.6	1379	114.4	543.9	-380.3	629.3	-554.5				
1155.1	3720	308.7	1379	-990.6	1626	-1436				
1229.75	8234	684.7	2779	-2071	3349	-2968				
1304.4	31340	2615	9485	-7247	11430	-10190				
1411	38670	3237	11220	-8649	13480	-12060				
1518	165500	14190	35280	-29890	42320	-37810				
1625	170900	14720	36240	-30920	43460	-38760				
1732	174900	15190	36930	-31680	44150	-39270				
1784.4	251900	25850	51220	-46200	56480	-47740				
1839	254700	26360	51740	-46630	56810	-48420				
1946	256900	27020	52090	-46760	56780	-48780				
2050.8	287300	20920	56230	-48150	51740	-49690				
2160	289500	21190	56570	-48350	51350	-49500				
2264.4	292400	22590	56790	-48440	50930	-49180				
2284.8	336200	34310	58520	-48930	45530	-43980				
2340.68	338600	35010	58590	-48950	45450	-43780				
2396.57	341400	36020	58590	-48930	45340	-43560				
2459.17	507600	101600	57290	-40110	63530	-72390				
2473.8	676500	165300	68600	-56980	108700	-115700				
2569.8	828500	214900	73290	-75220	132400	-135000				
2664.13	942000	242500	79530	-90050	141200	-130700				
2758.47	1009000	250200	90810	-114700	126600	-104900				
2852.8	1044000	257200	101600	-132500	93670	-85800				
2963.42	3219000	1303000	115000	-152400	51750	-60220				
2990.67	1653000	-421100	29300	-70980	65460	-56600				
3012.52	1677000	-410200	30400	-69500	59220	-51950				
3123.15	1728000	-396600	31380	-68070	48870	-45830				
3233.63	1776000	-386300	32690	-65990	37550	-41990				
3337.35	1829000	-375300	34660	-63660	43500	-39430				
3480.57	1880000	-364200	37450	-59610	50420	-45960				
3623.8	1921000	-353900	40480	-55030	57110	-53070				
3747.4	1946000	-344600	43040	-53310	62460	-58230				
3871	1955000	-337200	44580	-52100	65780	-61610				
3964.5	1948000	-330400	45130	-51100	67630	-66460				
4054	1915000	-323400	24990	-39520	63460	-60870				
4118.65	1858000	-315900	23500	-34920	57700	-55010				
4122.65	1799000	-308500	24660	-31620	51870	-49590				
4233.27	1851000	-90230	22640	-27200	43430	-41800				
4309.4	1317000	-61010	17350	-19980	31340	-29920				
4385.5	0.02736	-81.7	0.09784	-116.7	88.08	-0.2868				

NLS1 COMPOSITE MOMENT BODY LOADS W/O STME OUT (IN-LBS)

LIFTOFF

X-Station (in)	X-Dir.		Y-Dir.		Y-Dir.		Z-Dir.	
	Maximum	Minimum	Maximum	Minimum	Maximum	Minimum	Maximum	Minimum
1066.06	24950	-24730	0.01646	-0.02484	0.06142	-0.0006733	0.06142	-0.0006733
1110.6	30750	-29320	2022	-1757	1770	-1196	1770	-1196
1155.1	34150	-31480	30000	-26430	25970	-18120	25970	-18120
1229.75	35200	-31360	151400	-133600	128900	-92070	128900	-92070
1304.4	39180	-34620	577800	-510600	477800	-357600	477800	-357600
1411	47870	-39720	1796000	-1597000	1489000	-1130000	1489000	-1130000
1518	109200	-103700	5166000	-4578000	4331000	-3051000	4331000	-3051000
1625	115500	-113300	9557000	-8587000	7920000	-6177000	7920000	-6177000
1732	119900	-121100	14120000	-12730000	11800000	-9400000	11800000	-9400000
1784.4	147100	-172700	17860000	-16230000	14420000	-11810000	14420000	-11810000
1839	149700	-178300	20840000	-18780000	17200000	-14240000	17200000	-14240000
1946	150400	-181300	26790000	-23790000	22700000	-19130000	22700000	-19130000
2050.8	162700	-189100	33440000	-29280000	28610000	-24500000	28610000	-24500000
2160	165700	-192600	38940000	-33500000	34690000	-29440000	34690000	-29440000
2264.4	167900	-194800	44180000	-37480000	40510000	-34140000	40510000	-34140000
2284.8	198100	-222400	44650000	-37270000	42780000	-35220000	42780000	-35220000
2340.68	204700	-227500	47020000	-38980000	45860000	-37600000	45860000	-37600000
2396.57	216200	-232300	49380000	-40660000	48950000	-39970000	48950000	-39970000
2459.17	253600	-255900	52020000	-42740000	52400000	-42630000	52400000	-42630000
2473.8	278800	-282700	52010000	-42800000	52980000	-42980000	52980000	-42980000
2569.8	301200	-312200	48430000	-39790000	55230000	-44880000	55230000	-44880000
2664.13	320500	-339900	42970000	-34390000	55710000	-45250000	55710000	-45250000
2758.47	336700	-364900	37900000	-37620000	57680000	-43630000	57680000	-43630000
2852.8	367900	-422600	41980000	-45740000	60250000	-39970000	60250000	-39970000
2963.42	389300	-473100	50750000	-50430000	65620000	-49700000	65620000	-49700000
2990.67	696900	-1231000	51310000	-49780000	63480000	-42200000	63480000	-42200000
3012.52	715600	-1242000	51380000	-49620000	62090000	-41560000	62090000	-41560000
3123.15	699600	-1246000	50820000	-47930000	55160000	-38200000	55160000	-38200000
3233.63	677000	-1246000	49130000	-45300000	49010000	-34730000	49010000	-34730000
3337.35	643600	-1241000	46540000	-42070000	44000000	-31340000	44000000	-31340000
3480.57	599900	-1233000	41670000	-36400000	37250000	-26380000	37250000	-26380000
3623.8	607000	-1221000	35650000	-30670000	30360000	-21010000	30360000	-21010000
3747.4	654600	-1208000	29660000	-26190000	24340000	-17670000	24340000	-17670000
3871	693700	-1197000	23050000	-21470000	18360000	-13740000	18360000	-13740000
3964.5	722700	-1188000	17750000	-17740000	13950000	-10140000	13950000	-10140000
4054	459600	-539900	15610000	-16220000	10110000	-7952000	10110000	-7952000
4118.65	431800	-520500	11750000	-12250000	7751000	-6554000	7751000	-6554000
4122.65	408800	-501200	11530000	-12030000	7617000	-6462000	7617000	-6462000
4233.27	381200	-470300	6060000	-6460000	4166000	-3767000	4166000	-3767000
4309.4	373900	-461300	3106000	-3204000	2117000	-2065000	2117000	-2065000
4385.5	349.9	-0.4949	187900	-710.1	352.6	-439100	352.6	-439100

NLS1 COMPOSITE LINE BODY LOADS W/O STME OUT

LIFTOFF

X-Station (in)	NX+ (lbs/in)		NX- (lbs/in)		NX- (lbs/in)		NX+ (lbs/in)		PEQ+ (lbs)		PEQ- (lbs)		
	Maximum	Minimum	Maximum	Minimum	Maximum	Minimum	Maximum	Minimum	Maximum	Minimum	Maximum	Minimum	
1066.06	0	0	0	0	0	0	0	0	0	0	0	0	
1110.6	6.272	0.5201	6.272	0.5201	6.272	0.5201	6.272	0.5201	6.272	1379	114.4	1379	114.4
1155.1	9.869	0.8188	9.869	0.8188	9.869	0.8188	9.869	0.8188	9.869	3720	308.7	3720	308.7
1229.75	16.38	1.362	16.38	1.362	16.38	1.362	16.38	1.362	16.38	8234	684.7	8234	684.7
1304.4	51.05	4.169	49.5	2.828	49.5	2.828	49.5	2.828	49.5	31100	1777	31100	1777
1411	61.54	5.152	61.54	5.152	61.54	5.152	61.54	5.152	61.54	38670	3237	38670	3237
1518	307.9	22.63	260.1	6.425	260.1	6.425	260.1	6.425	260.1	163400	4037	163400	4037
1625	272	23.43	272	23.43	272	23.43	272	23.43	272	170900	14720	170900	14720
1732	278.3	24.18	278.3	24.18	278.3	24.18	278.3	24.18	278.3	174900	15190	174900	15190
1784.4	412.5	41.18	390.6	39.21	390.6	39.21	390.6	39.21	390.6	245400	24640	245400	24640
1839	405.4	41.95	405.4	41.95	405.4	41.95	405.4	41.95	405.4	254700	26360	254700	26360
1946	408.9	43.01	408.9	43.01	408.9	43.01	408.9	43.01	408.9	256900	27020	256900	27020
2050.8	460.6	35.53	454.5	30.87	454.5	30.87	454.5	30.87	454.5	285600	19390	285600	19390
2160	460.8	33.72	460.8	33.72	460.8	33.72	460.8	33.72	460.8	289500	21190	289500	21190
2264.4	465.4	35.95	465.4	35.95	465.4	35.95	465.4	35.95	465.4	292400	22590	292400	22590
2284.8	528	71.86	490.3	26.49	490.3	26.49	490.3	26.49	490.3	327700	17710	327700	17710
2340.68	435.1	44.99	435.1	44.99	435.1	44.99	435.1	44.99	435.1	338600	35010	338600	35010
2396.57	384.4	40.56	384.4	40.56	384.4	40.56	384.4	40.56	384.4	341400	36020	341400	36020
2459.17	502	100.4	502	100.4	502	100.4	502	100.4	502	507600	101600	507600	101600
2473.8	650.5	159	650.5	159	650.5	159	650.5	159	650.5	676500	165300	676500	165300
2569.8	796.7	206.6	796.7	206.6	796.7	206.6	796.7	206.6	796.7	828500	214900	828500	214900
2664.13	905.9	233.2	905.9	233.2	905.9	233.2	905.9	233.2	905.9	942000	242500	942000	242500
2758.47	970.4	240.6	970.4	240.6	970.4	240.6	970.4	240.6	970.4	1009000	250200	1009000	250200
2852.8	1004	247.3	1004	247.3	1004	247.3	1004	247.3	1004	1044000	257200	1044000	257200
2963.42	3096	1253	3096	1253	3096	1253	3096	1253	3096	3219000	1303000	3219000	1303000
2990.67	2236	-404.9	1574	-982.7	1574	-982.7	1574	-982.7	1574	1637000	-1022000	1637000	-1022000
3012.52	1612	-394.5	1612	-394.5	1612	-394.5	1612	-394.5	1612	1677000	-410200	1677000	-410200
3123.15	1662	-381.4	1662	-381.4	1662	-381.4	1662	-381.4	1662	1728000	-396600	1728000	-396600
3233.63	1708	-371.5	1708	-371.5	1708	-371.5	1708	-371.5	1708	1776000	-386300	1776000	-386300
3337.35	1759	-360.9	1759	-360.9	1759	-360.9	1759	-360.9	1759	1829000	-375300	1829000	-375300
3480.57	1808	-350.2	1808	-350.2	1808	-350.2	1808	-350.2	1808	1880000	-364200	1880000	-364200
3623.8	1847	-340.3	1847	-340.3	1847	-340.3	1847	-340.3	1847	1921000	-353900	1921000	-353900
3747.4	1871	-331.4	1871	-331.4	1871	-331.4	1871	-331.4	1871	1946000	-344600	1946000	-344600
3871	1880	-324.2	1880	-324.2	1880	-324.2	1880	-324.2	1880	1955000	-337200	1955000	-337200
3964.5	1874	-317.7	1874	-317.7	1874	-317.7	1874	-317.7	1874	1948000	-330400	1948000	-330400
4054	1842	-311	1842	-311	1842	-311	1842	-311	1842	1915000	-323400	1915000	-323400
4118.65	1787	-303.8	1787	-303.8	1787	-303.8	1787	-303.8	1787	1858000	-315900	1858000	-315900
4122.65	1730	-296.7	1730	-296.7	1730	-296.7	1730	-296.7	1730	1799000	-308500	1799000	-308500
4233.27	1780	-86.77	1780	-86.77	1780	-86.77	1780	-86.77	1780	1851000	-90230	1851000	-90230
4309.4	1266	-58.67	1266	-58.67	1266	-58.67	1266	-58.67	1266	1317000	-61010	1317000	-61010
4385.5	13.89	-0.03237	-5.054E-06	-13.89	-5.054E-06	-13.89	-5.054E-06	-13.89	-5.054E-06	-0.005256	-14440	-0.005256	-14440

**NLS1 CORE LIFTOFF W/O STME OUT
COMPOSITE AXIAL SHEAR LOADS VS X-STATION**

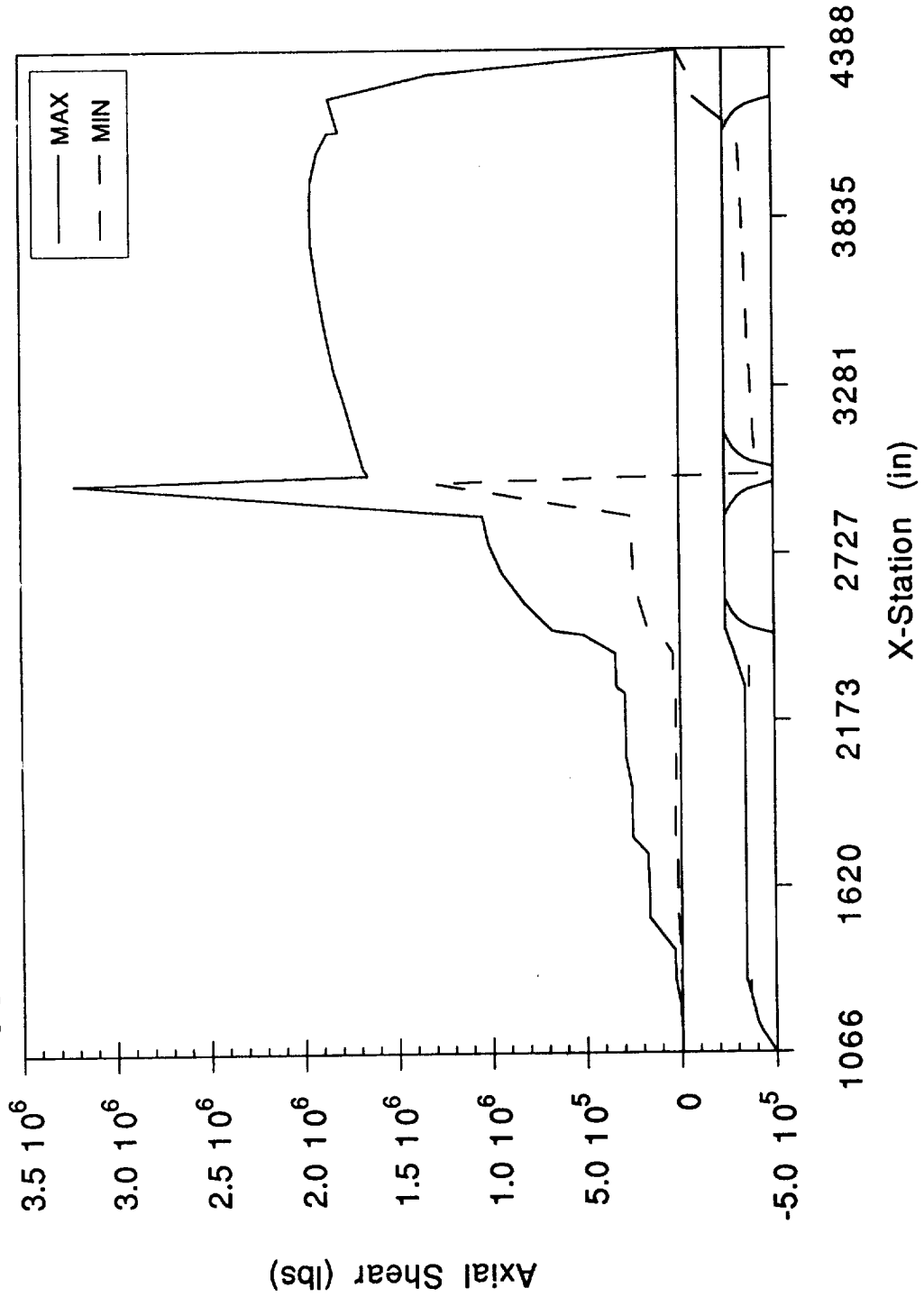

NLS1 CORE LIFTOFF W/O STME OUT COMPOSITE Y-DIR SHEAR LOADS VS X-STATION

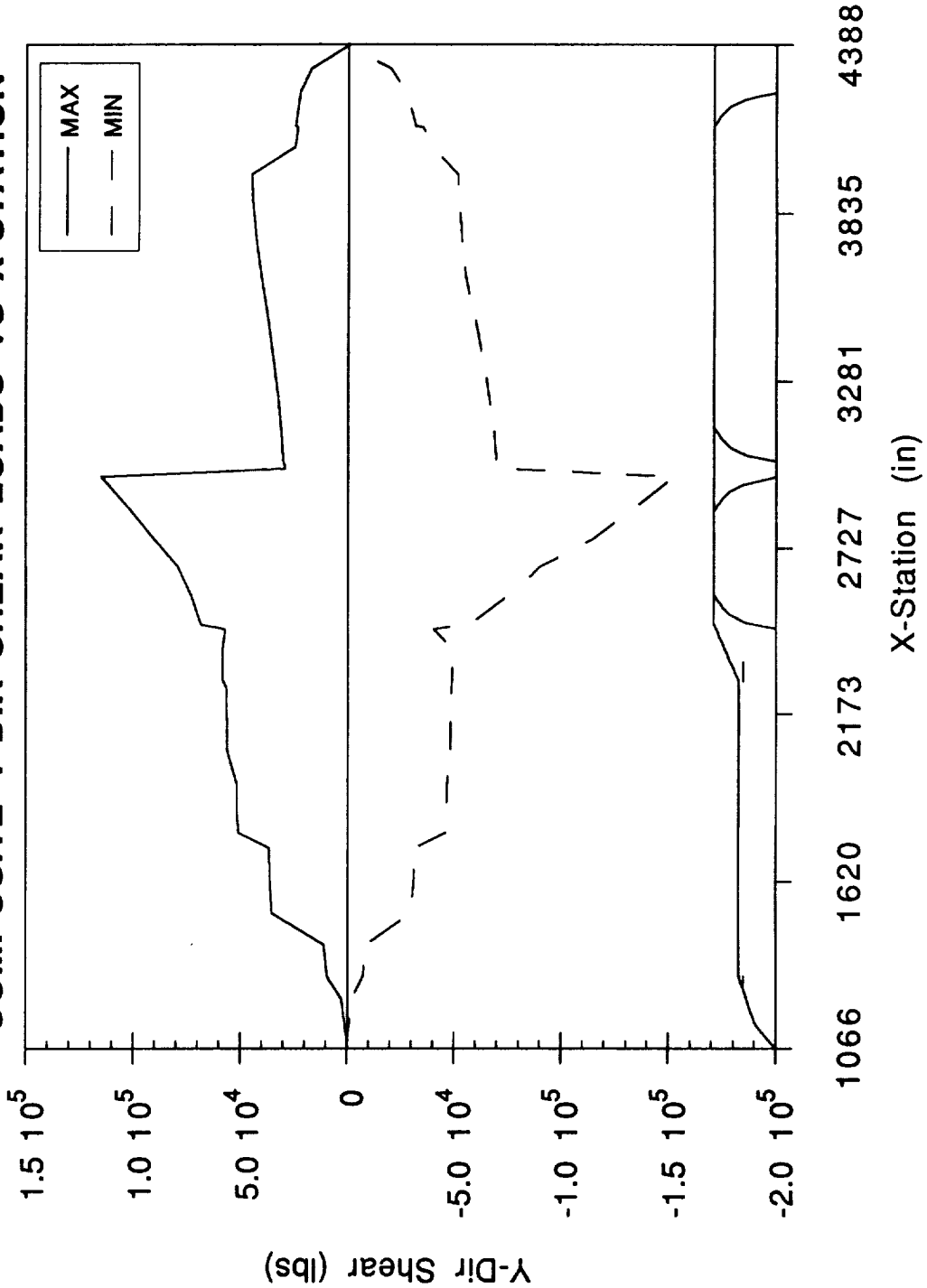

(((

**NLS1 CORE LIFTOFF W/O STME OUT
COMPOSITE Z-DIR SHEAR LOADS VS X-STATION**

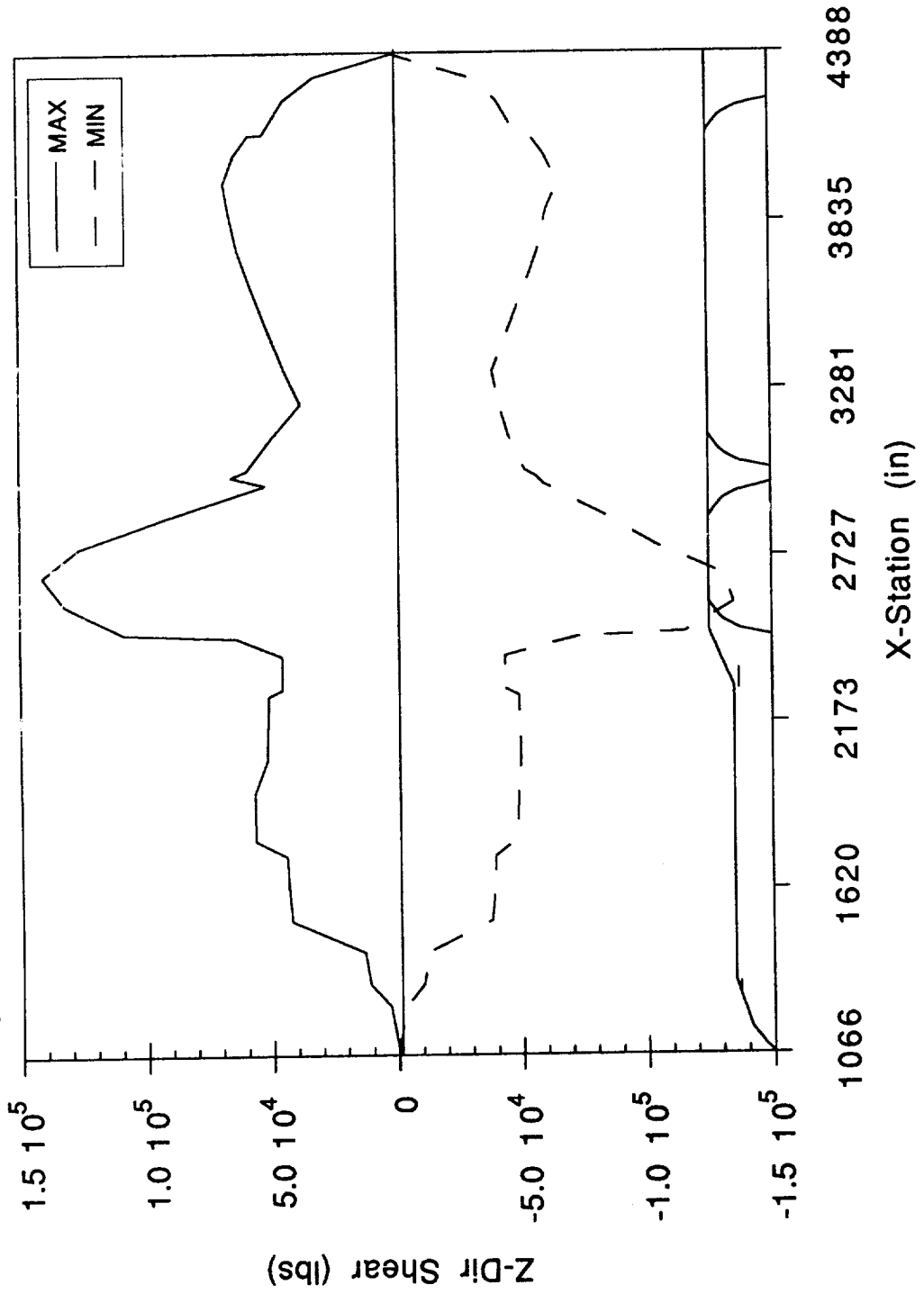

NLS1 CORE LIFTOFF W/O STME OUT COMPOSITE X-DIR TORSION VS X-STATION

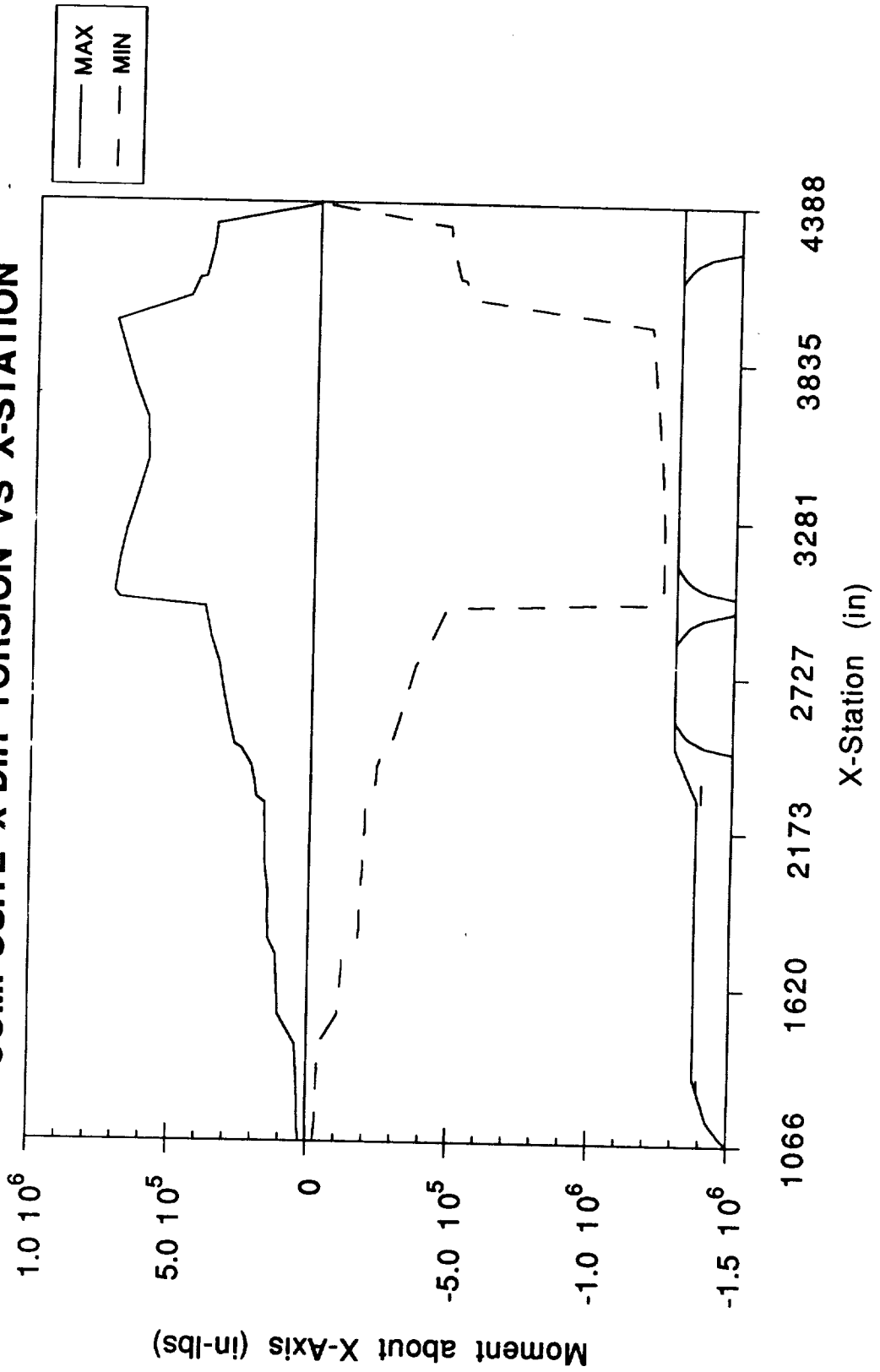

(((

**NLS1 CORE LIFTOFF W/O STME OUT
COMPOSITE Y-DIR MOMENT VS X-STATION**

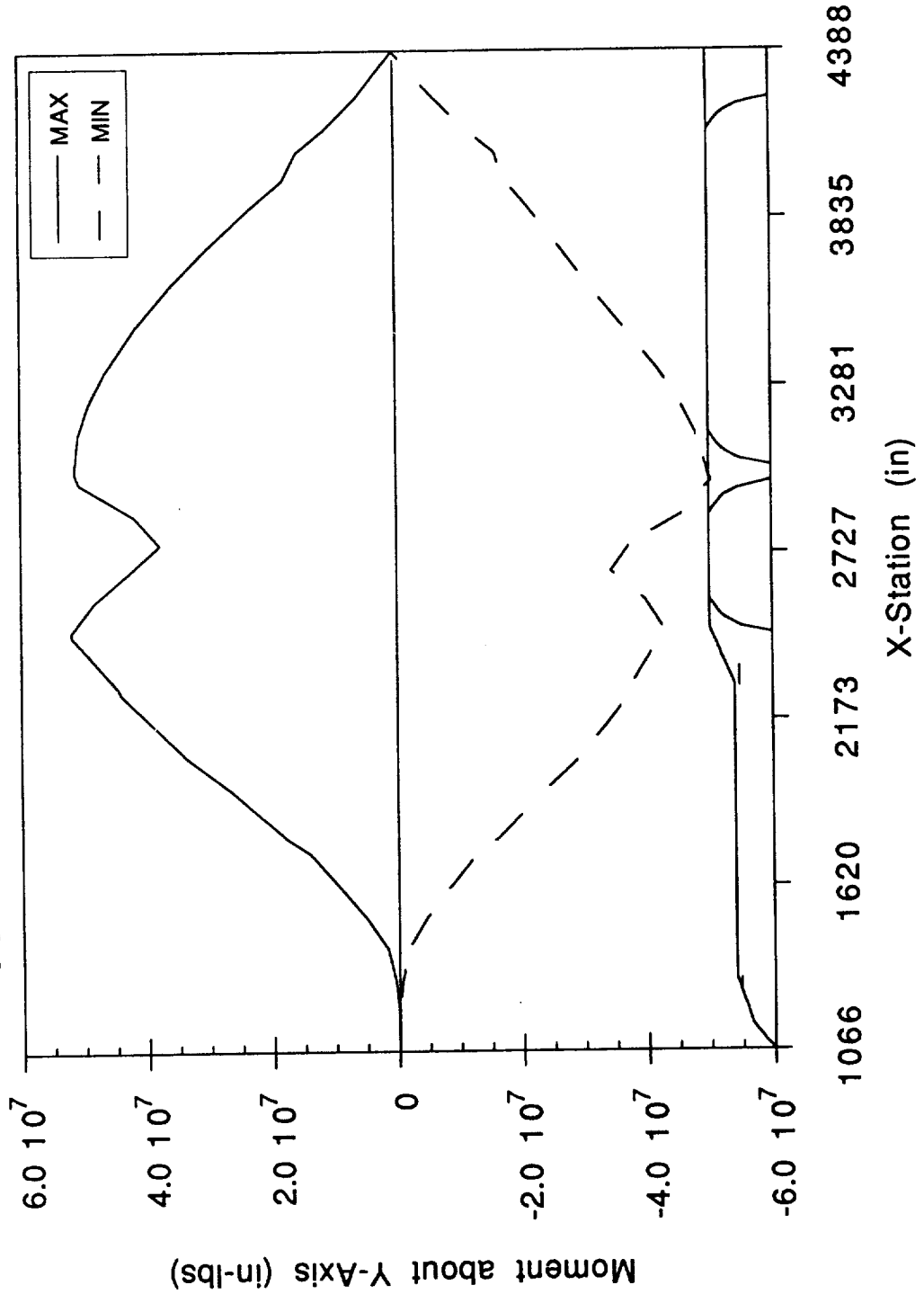

**NLS1 CORE LIFTOFF W/O STME OUT
COMPOSITE Z-DIR MOMENT VS X-STATION**

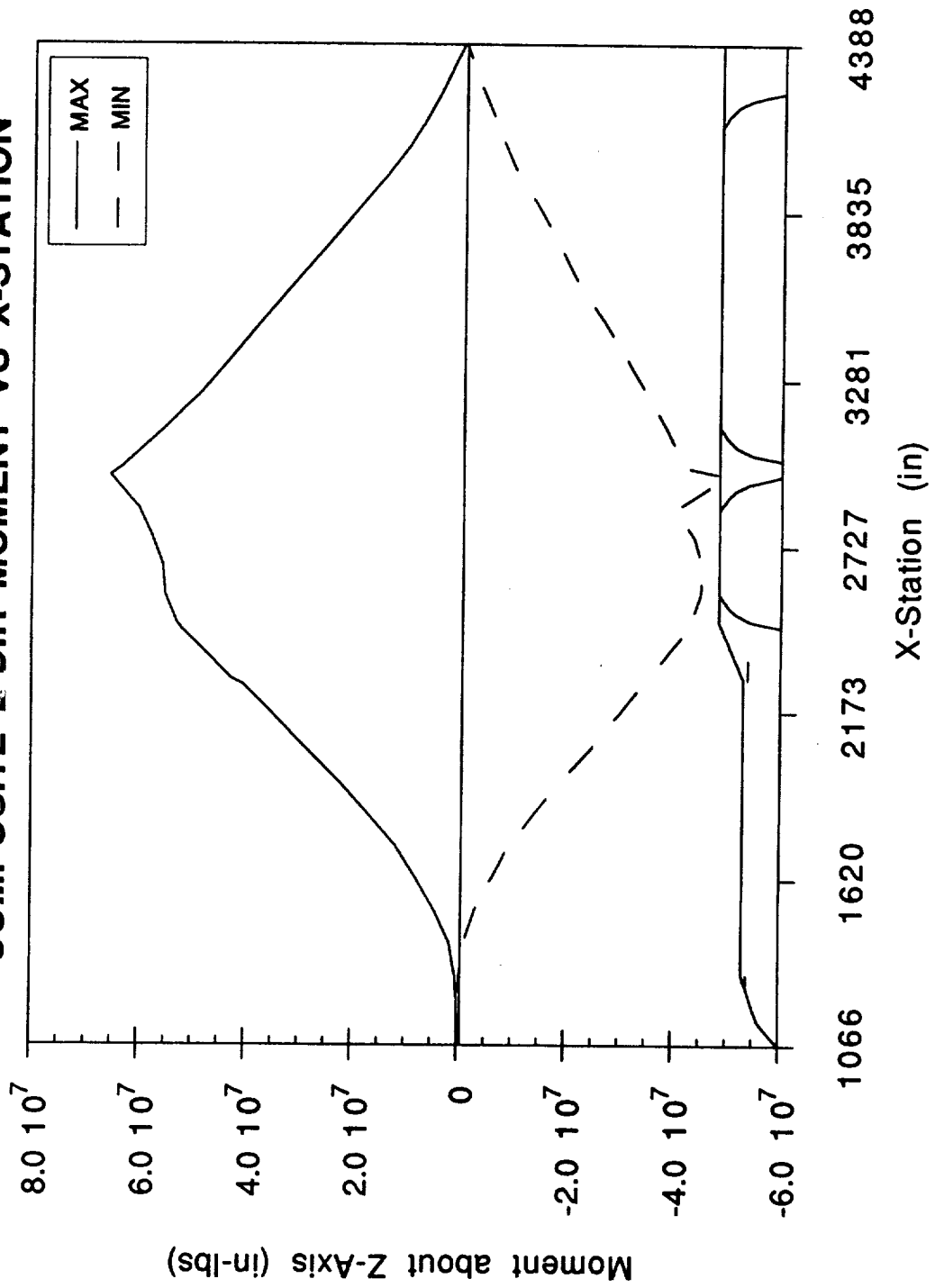

**NLS1 CORE LIFTOFF W/O STME OUT
COMPOSITE NX+ LOADS VS X-STATION**

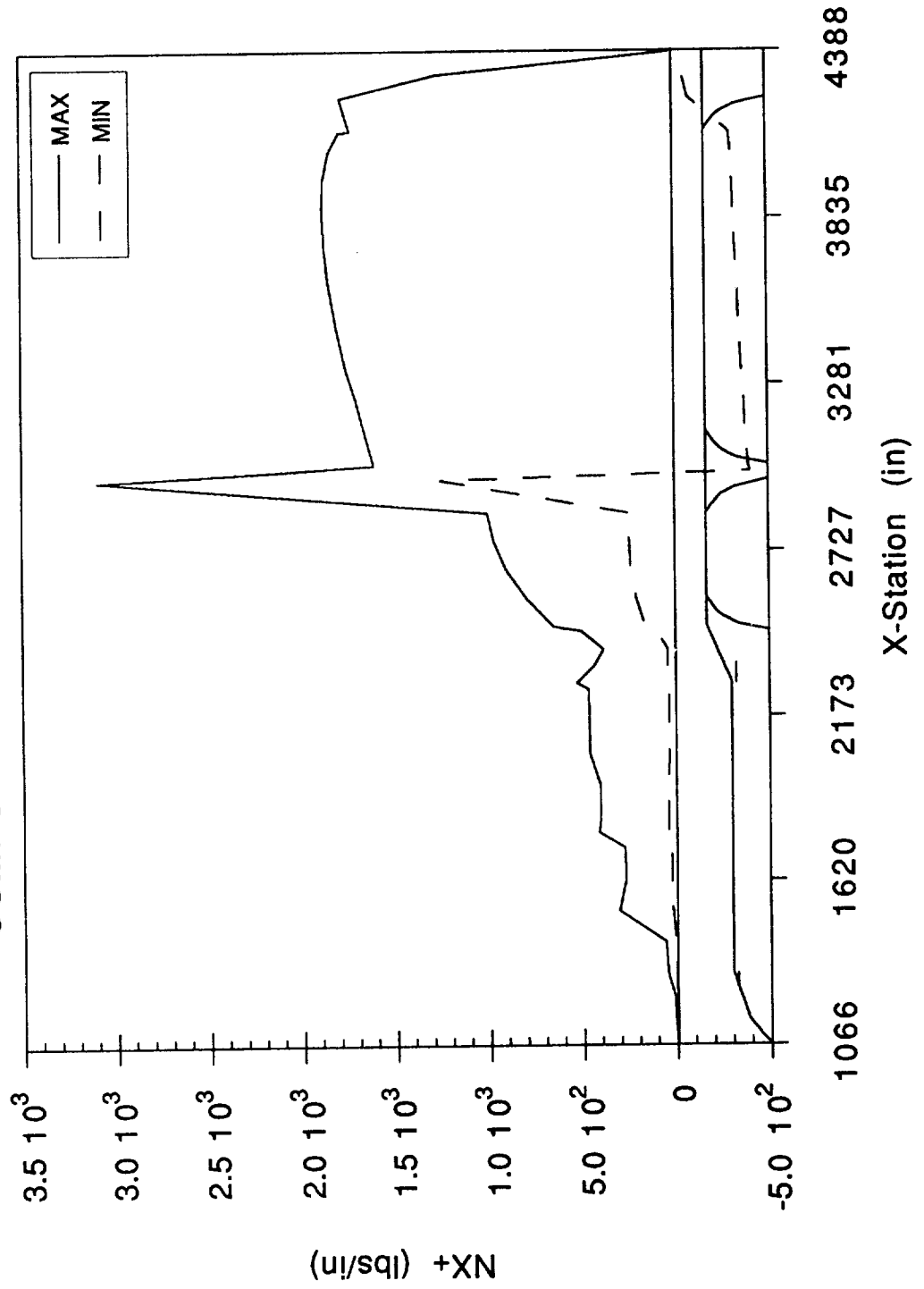

NLS1 CORE LIFTOFF W/O STME OUT COMPOSITE NX- LOADS VS X-STATION

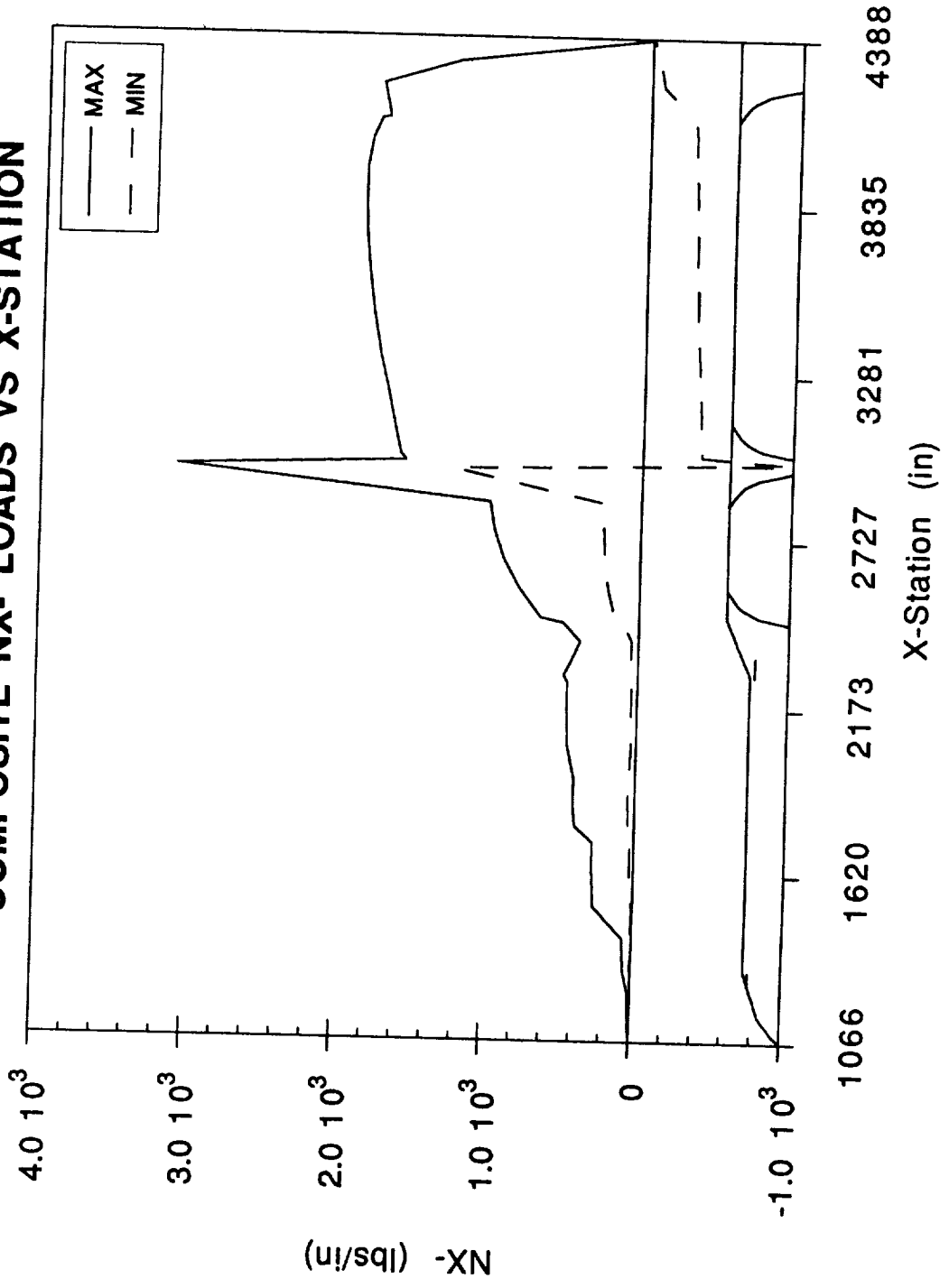

NLS 2

LIFTOFF DATA

)

)

)

NLS2 WITH STME OUT LIFTOFF PAD FORCES (KIPS)

PAD NUMBER	MAXIMUM			MINIMUM		
	X-DIR	Y-DIR	Z-DIR	X-DIR	Y-DIR	Z-DIR
M1	319.8	24.9	13.7	-745.6	-54.1	-27.3
M2	541.9	52.6	5.1	-478.9	-65.3	-11
M3	553.1	32.4	11.3	-502.5	-54.7	-27.8
M4	280.7	36.6	3.3	-721.2	-36	-17.6

NLS2 WITH OUT STME OUT LIFTOFF PAD FORCES (KIPS)

PAD NUMBER	MAXIMUM			MINIMUM		
	X-DIR	Y-DIR	Z-DIR	X-DIR	Y-DIR	Z-DIR
M1	319.8	24.9	13.5	-745.6	-54.1	-27.3
M2	541.2	52.6	5.1	-478.9	-60.8	-11
M3	553.1	32.4	11.3	-502.5	-54.7	-27.8
M4	280.7	36.6	3.3	-721.2	-31.6	-17.6

NLS2 LV Liftoff Accelerations (G's)

	W/STME Out		W/O STME Out	
	Maximum	Minimum	Maximum	Minimum
Node 999 Payload 50K X-Dir	5.263	-6.159	5.263	-6.157
Node 999 Payload 50K Y-Dir	3.234	-2.792	3.234	-2.792
Node 999 Payload 50K Z-Dir	2.414	-2.536	2.414	-2.499
Node 80 LO2 Slosh X-Dir	1.5582	-0.752	1.5539	-0.752
Node 81 LH2 Slosh X-Dir	5.665	-4.628	5.662	-4.628

NLS2 COMPOSITE SHEAR BODY LOADS W/STME OUT (LBS)

LIFTOFF

X-Station (in)	X-Dir.		Y-Dir.		Z-Dir.	
	Maximum	Minimum	Maximum	Minimum	Maximum	Minimum
1306.1	260.4	-158.7	300.7	-307.3	303.5	-188.8
1395.1	4164	-2538	4220	-4306	3530	-1870
1444.9	11260	-6856	10780	-10990	9020	-4412
1494.6	24980	-15180	22560	-22880	18820	-9172
1544.4	33880	-20540	29710	-30030	24890	-12020
1624.4	42130	-25410	35670	-35900	30460	-14360
1704.4	49600	-29690	40510	-40530	35340	-16290
1784.4	56170	-33290	44310	-44000	39550	-17960
1864.4	61720	-36110	47120	-46430	43090	-19410
1944.4	66190	-38100	49420	-47940	46010	-20720
2024.4	69530	-39230	52050	-48710	48390	-21910
2104.4	71880	-40250	54310	-48890	50340	-23110
2184.4	73310	-40510	56700	-48880	52070	-29990
2264.4	73710	-39980	59430	-49050	53860	-38440
2284.8	461400	-192200	159600	-139200	195300	-211100
2347.8	462100	-192900	161400	-138600	204800	-222400
2410.8	461800	-193200	162400	-137900	209400	-228000
2459.2	862900	-264100	404600	-468400	335200	-364600
2471.1	1271000	-352000	612500	-625100	500900	-376300
2569.8	1227000	-281300	461400	-433600	457100	-375000
2664.1	1586000	-324100	711300	-425700	565500	-328100
2758.5	1576000	-271500	492300	-390400	515000	-335200
2852.8	1600000	-152100	634100	-511500	474100	-447000
2963.4	1645000	-209700	370800	-312800	326200	-241800
2985.7	3657000	1011000	370500	-320800	328600	-244300
3012.5	3672000	1031000	375900	-367100	334100	-250200
3123.1	3622000	1031000	267800	-267900	207100	-211700
3240	3608000	1048000	272800	-265400	246500	-221800
3356.9	3661000	1032000	245800	-285000	190700	-196700
3473.7	3708000	1024000	227500	-202100	212500	-178700
3590.6	3715000	1071000	185000	-236700	145100	-238800
3707.4	3677000	1044000	151500	-225900	158800	-242300
3824.3	3601000	1038000	121200	-309700	125000	-268300
3941.1	3580000	1073000	156100	-309700	125000	-339600
4058	3562000	1035000	245600	-358000	139600	-379400
4090.3	3532000	1017000	298100	-473800	177200	-429400
4122.6	3506000	1054000	312500	-522500	212200	-458100
4166.6	4066000	1233000	297700	-319800	221300	-288100
4210.3	4058000	1360000	270400	-321500	202200	-273900
4227.4	4051000	1420000	263000	-329300	199700	-269500
4254	3968000	1692000	193800	-285400	192500	-345100
4297.8	4060000	1712000	162100	-341600	197000	-311100
4341.6	4091000	1169000	200600	-322800	200200	-267800
4385.5	3939	-0.1894	0.3714	-765.7	0.8306	-2389

NLS2 COMPOSITE MOMENT BODY LOADS W/STME OUT (IN-LBS)

LIFTOFF

X-Station (in)	X-Dir.		Y-Dir.		Z-Dir.	
	Maximum	Minimum	Maximum	Minimum	Maximum	Minimum
1306.1	1740	-1554	2.221	0.0005961	0.0006522	-6.266
1395.1	12740	-11380	27020	-16810	26770	-27360
1444.9	27190	-24280	198100	-109900	236800	-241700
1494.6	58180	-51950	647000	-316800	773200	-788500
1544.4	323800	-289100	1583000	-773200	1895000	-1927000
1624.4	478300	-426800	3561000	-1735000	4271000	-4330000
1704.4	554100	-494100	5977000	-2884000	7125000	-7201000
1784.4	584400	-520800	8805000	-4181000	10370000	-10440000
1864.4	595000	-530000	11970000	-5593000	13910000	-13960000
1944.4	601400	-535400	15420000	-7123000	17680000	-17680000
2024.4	607700	-540300	19100000	-8745000	21610000	-21510000
2104.4	607100	-545300	22970000	-10470000	25640000	-25410000
2184.4	582100	-554400	27000000	-12270000	29760000	-29320000
2264.4	512500	-536100	31160000	-14170000	33940000	-33220000
2284.8	1361000	-1381000	67400000	-50460000	68160000	-58650000
2347.8	1337000	-1396000	71370000	-52440000	77640000	-66930000
2410.8	1279000	-1398000	76310000	-59970000	87160000	-75110000
2459.2	1174000	-1438000	84440000	-63630000	94520000	-81320000
2471.1	1215000	-1493000	85430000	-63360000	94140000	-80590000
2569.8	1227000	-1511000	80880000	-76540000	95010000	-75800000
2664.1	1229000	-1517000	79970000	-73590000	84230000	-76230000
2758.5	1226000	-1517000	78140000	-56780000	91560000	-79440000
2852.8	1192000	-1531000	93740000	-64520000	102700000	-59460000
2963.4	1136000	-1625000	88860000	-63390000	101900000	-59700000
2985.7	1136000	-1625000	85430000	-63000000	94980000	-58330000
3012.5	3214000	-2904000	81390000	-63320000	86360000	-56740000
3123.1	1714000	-2563000	67810000	-61230000	65350000	-51890000
3240	2476000	-2789000	75440000	-63230000	74090000	-51680000
3356.9	1912000	-2915000	72440000	-69530000	73870000	-54040000
3473.7	1348000	-2978000	87250000	-70900000	88210000	-68350000
3590.6	1360000	-3014000	86570000	-74110000	89010000	-75640000
3707.4	1374000	-3057000	94240000	-75110000	94310000	-74340000
3824.3	1936000	-3144000	103400000	-71790000	90200000	-66960000
3941.1	2921000	-3310000	112500000	-66480000	94330000	-58880000
4058	4473000	-4632000	121500000	-57280000	97640000	-54770000
4090.3	4746000	-5031000	124000000	-54080000	101900000	-53100000
4122.6	4377000	-5066000	126400000	-53940000	106900000	-50590000
4166.6	4071000	-4960000	130100000	-50520000	111500000	-55160000
4210.3	4251000	-5051000	133200000	-47850000	109000000	-52790000
4227.4	4523000	-5090000	134400000	-45970000	106600000	-52690000
4254	5466000	-6479000	136200000	-53240000	98910000	-53420000
4297.8	7569000	-5543000	139100000	-79150000	102000000	-71620000
4341.6	8054000	-5889000	142300000	-95070000	105100000	-91920000
4385.5	49490	-24.93	14940000	-16520000	16830000	-19210000

NLS2 COMPOSITE LINE BODY LOADS W/STME OUT

LIFTOFF

X-Station (in)	NX+ (lbs/in) Maximum	NX+ (lbs/in) Minimum	NX- (lbs/in) Maximum	NX- (lbs/in) Minimum	PEQ+ (lbs) Maximum	PEQ+ (lbs) Minimum	PEQ- (lbs) Maximum	PEQ- (lbs) Minimum
1306.1	0	0	0	0	0	0	0	0
1395.1	18.93	-11.54	18.93	-11.54	4164	-2538	4164	-2538
1444.9	29.86	-18.19	29.86	-18.19	11260	-6856	11260	-6856
1494.6	49.7	-30.21	49.7	-30.21	24980	-15180	24980	-15180
1544.4	53.91	-32.69	53.91	-32.69	33880	-20540	33880	-20540
1624.4	67.05	-40.44	67.05	-40.44	42130	-25410	42130	-25410
1704.4	78.95	-47.26	78.95	-47.26	49600	-29690	49600	-29690
1784.4	89.39	-52.98	89.39	-52.98	56170	-33290	56170	-33290
1864.4	98.23	-57.47	98.23	-57.47	61720	-36110	61720	-36110
1944.4	105.3	-60.64	105.3	-60.64	66190	-38100	66190	-38100
2024.4	110.7	-62.44	110.7	-62.44	69530	-39230	69530	-39230
2104.4	114.4	-64.07	114.4	-64.07	71880	-40250	71880	-40250
2184.4	116.7	-64.47	116.7	-64.47	73310	-40510	73310	-40510
2264.4	117.3	-63.63	117.3	-63.63	73710	-39980	73710	-39980
2284.8	2440	-230.9	710.9	-2179	1533000	-145100	446700	-1369000
2347.8	614.4	-256.5	614.4	-256.5	462100	-192900	462100	-192900
2410.8	527.2	-220.6	527.2	-220.6	461800	-193200	461800	-193200
2459.2	888.9	-272	888.9	-272	862900	-264100	862900	-264100
2471.1	1278	-353.9	1278	-353.9	1271000	-352000	1271000	-352000
2569.8	1180	-270.5	1180	-270.5	1227000	-281300	1227000	-281300
2664.1	1525	-311.6	1525	-311.6	1586000	-324100	1586000	-324100
2758.5	1516	-261.1	1516	-261.1	1576000	-271500	1576000	-271500
2852.8	1538	-146.2	1538	-146.2	1600000	-152100	1600000	-152100
2963.4	1582	-201.7	1582	-201.7	1645000	-209700	1645000	-209700
2985.7	3517	972.6	3517	972.6	3657000	1011000	3657000	1011000
3012.5	3531	991	3531	991	3672000	1031000	3672000	1031000
3123.1	3483	991	3483	991	3622000	1031000	3622000	1031000
3240	3469	1008	3469	1008	3608000	1048000	3608000	1048000
3356.9	3521	992	3521	992	3661000	1032000	3661000	1032000
3473.7	3566	984.4	3566	984.4	3708000	1024000	3708000	1024000
3590.6	3573	1030	3573	1030	3715000	1071000	3715000	1071000
3707.4	3536	1004	3536	1004	3677000	1044000	3677000	1044000
3824.3	3463	998	3463	998	3601000	1038000	3601000	1038000
3941.1	3443	1032	3443	1032	3580000	1073000	3580000	1073000
4058	3425	995.5	3425	995.5	3562000	1035000	3562000	1035000
4090.3	3397	978	3397	978	3532000	1017000	3532000	1017000
4122.6	3372	1013	3372	1013	3506000	1054000	3506000	1054000
4166.6	4117	1188	3884	923.2	4281000	1236000	4039000	960000
4210.3	3904	1313	3900	1226	4060000	1365000	4056000	1275000
4227.4	3896	1369	3896	1327	4052000	1423000	4051000	1380000
4254	4013	1633	3806	1446	4173000	1698000	3958000	1504000
4297.8	4113	1671	3882	1186	4277000	1737000	4036000	1233000
4341.6	4071	1151	3912	773.1	4234000	1197000	4067000	804000
4385.5	1705	0.2368	0.177	-1705	1773000	246.2	184	-1773000

NLS2 LIFTOFF W/STME OUT
COMPOSITE AXIAL SHEAR LOADS VS X-STATION

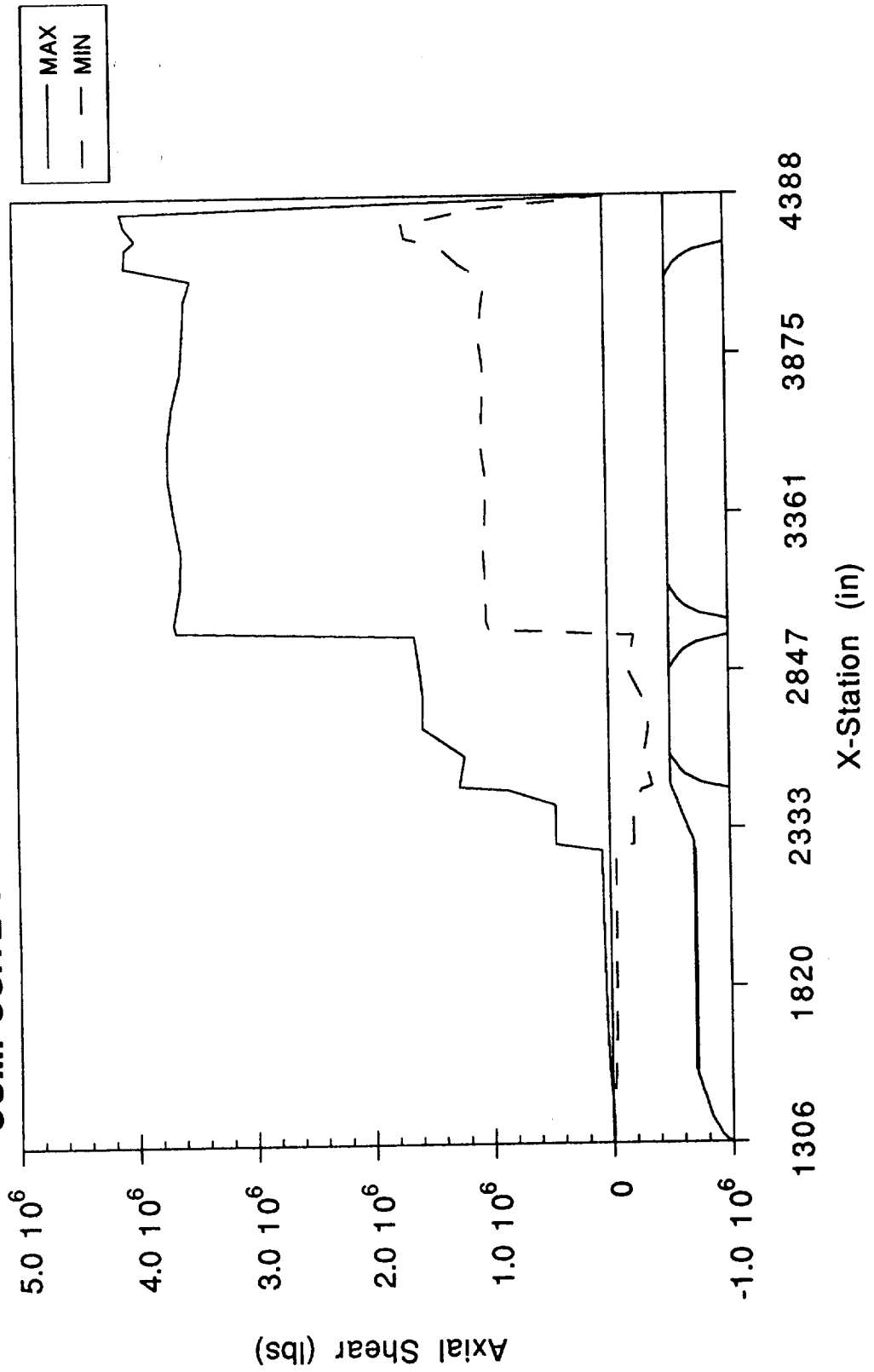

NLS2 LIFTOFF W/STME OUT COMPOSITE Y-DIR SHEAR LOADS VS X-STATION

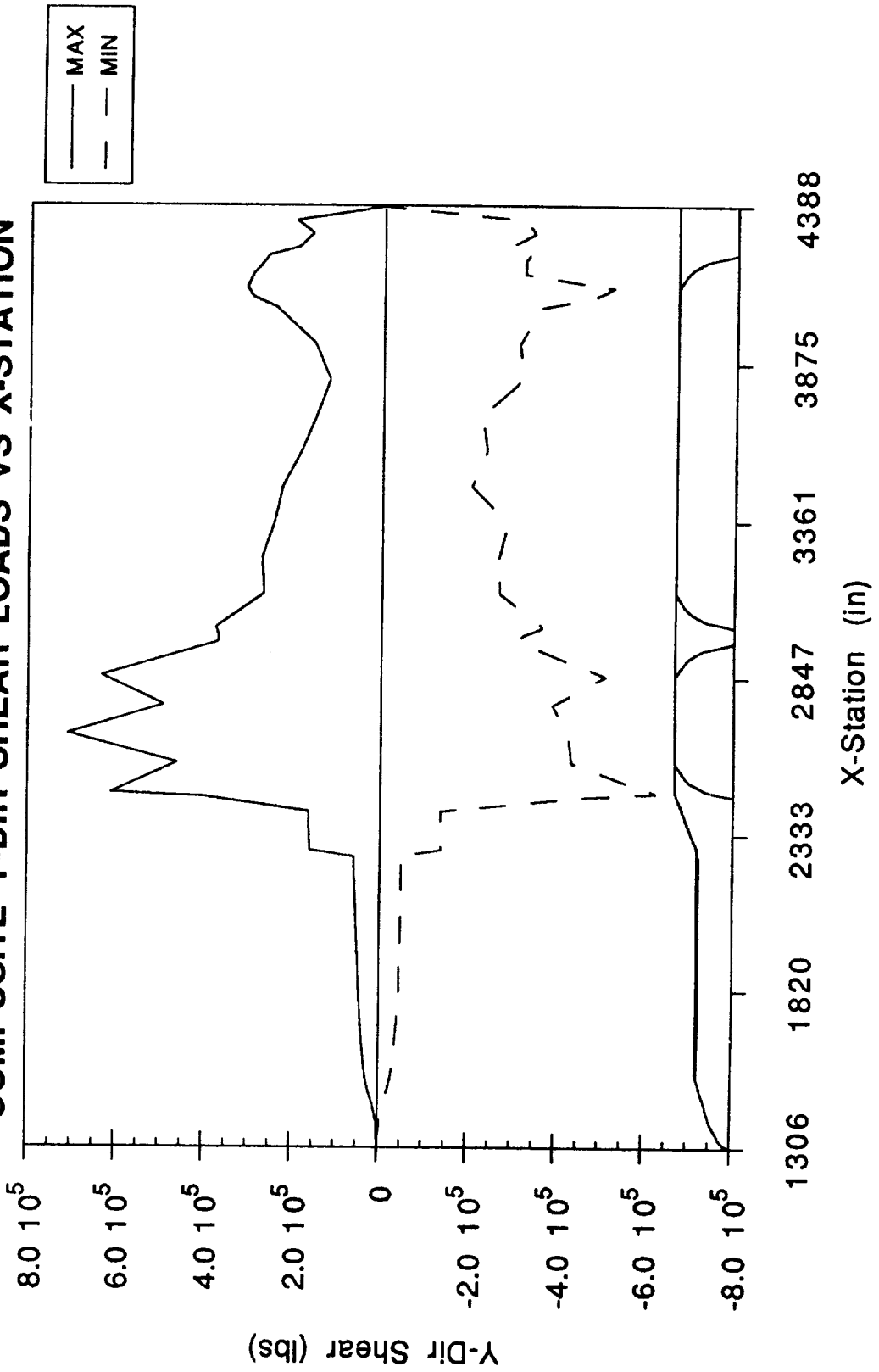

((

**NLS2 LIFTOFF W/STME OUT
COMPOSITE Z-DIR SHEAR LOADS VS X-STATION**

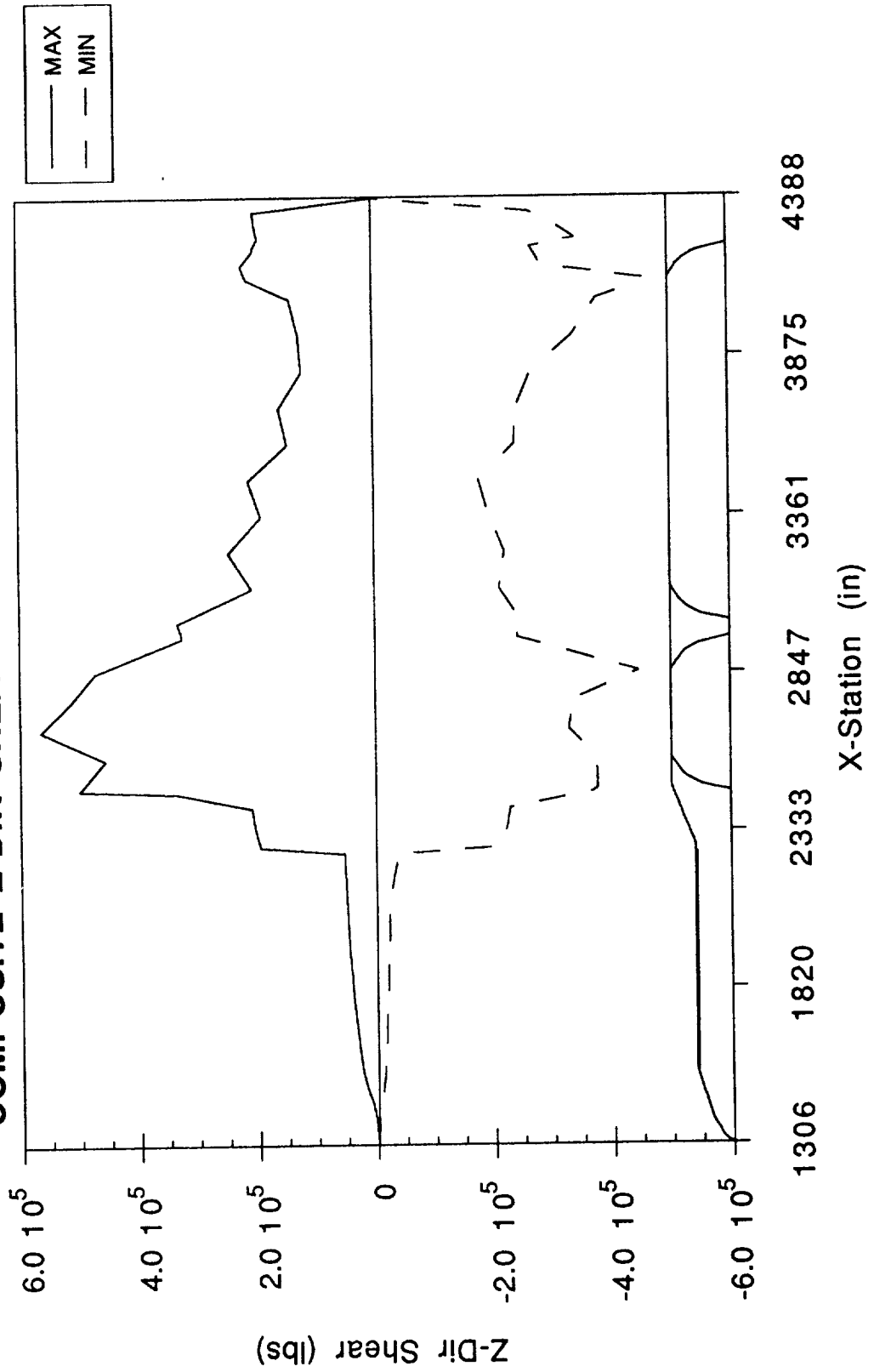

**NLS2 LIFTOFF W/STME OUT
COMPOSITE X-DIR TORSION VS X-STATION**

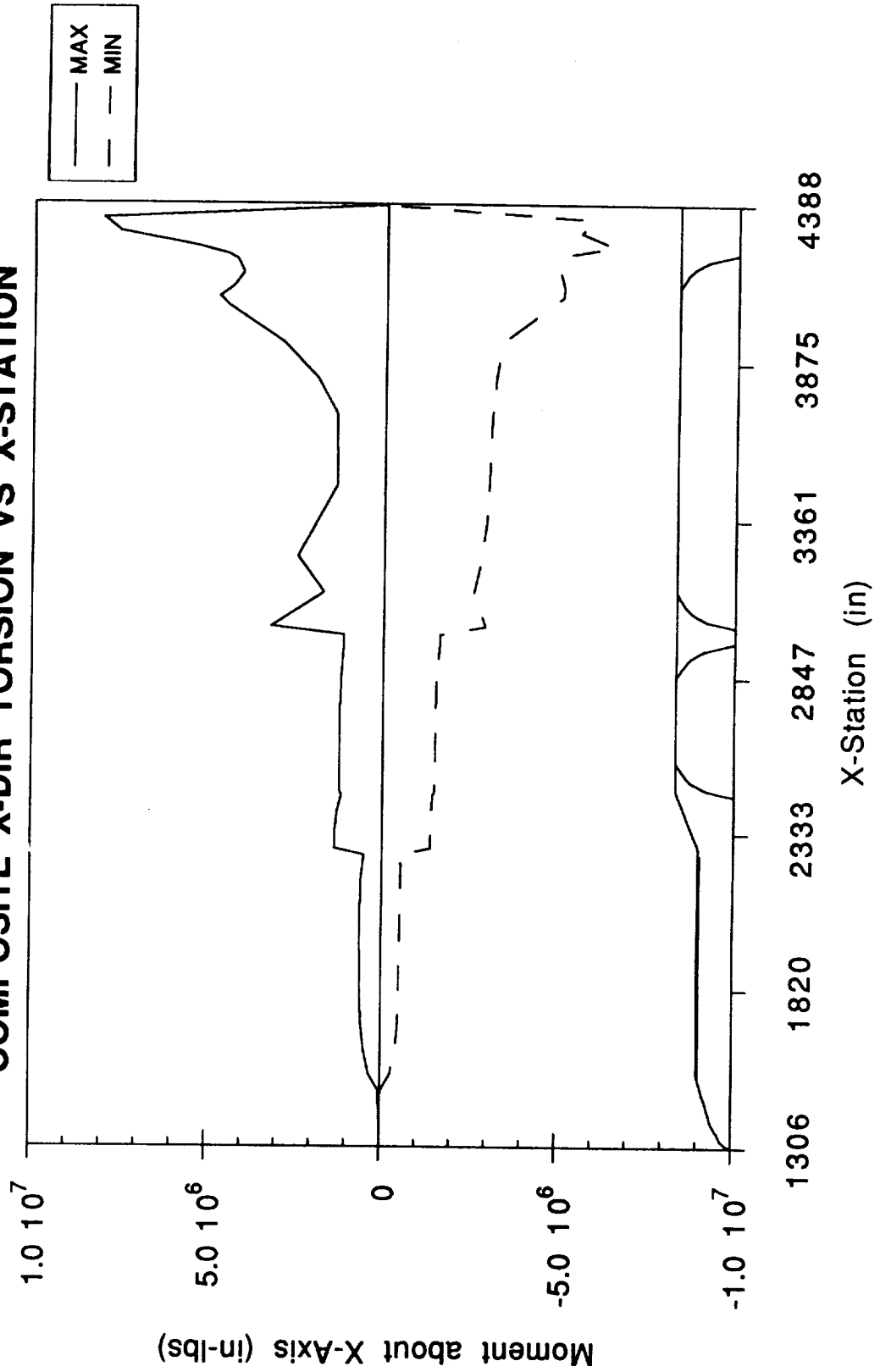

NLS2 LIFTOFF W/STME OUT
COMPOSITE Y-DIR MOMENT VS X-STATION

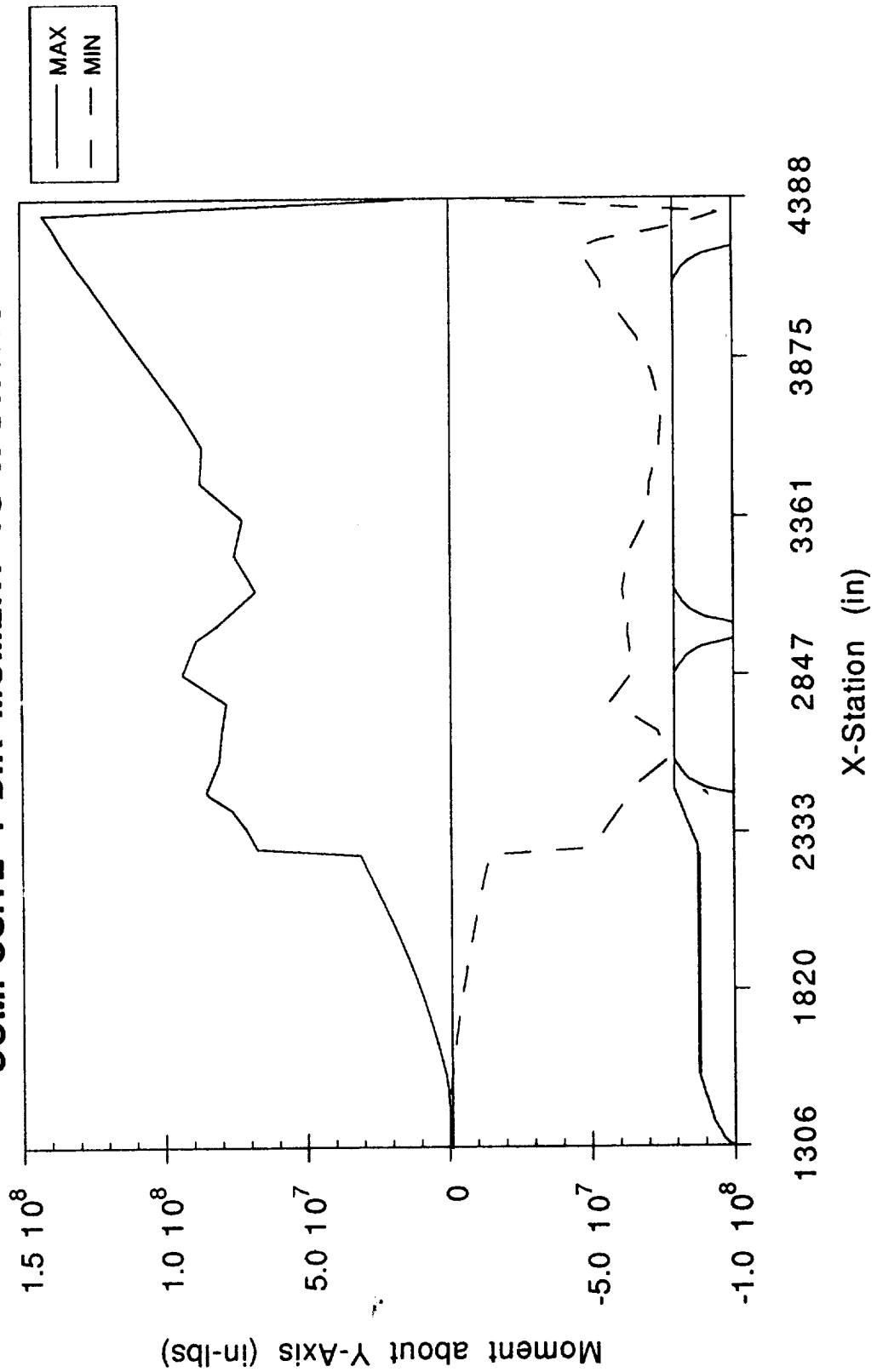

NLS2 LIFTOFF W/STME OUT COMPOSITE Z-DIR MOMENT VS X-STATION

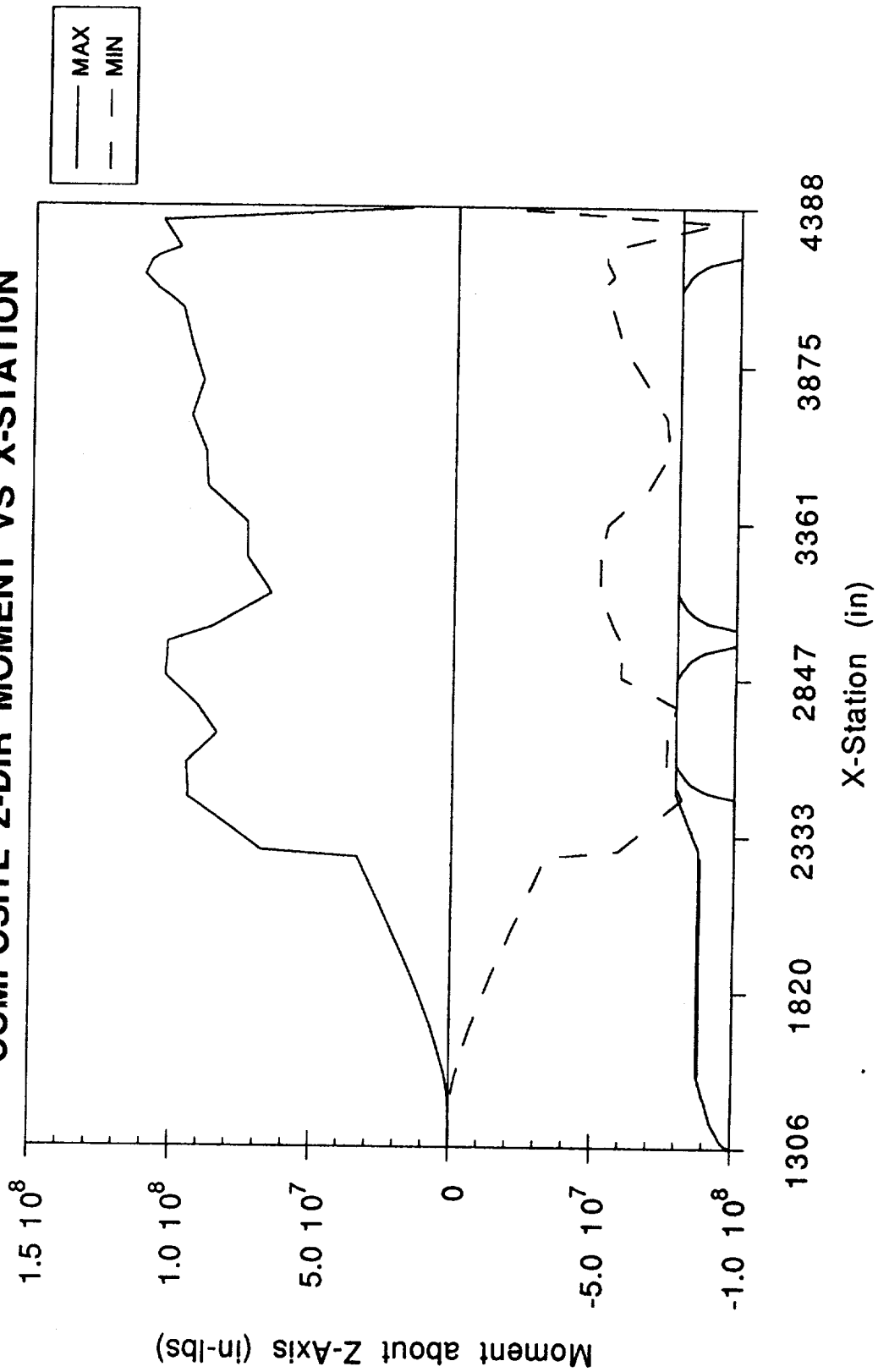

(. ()

**NLS2 LIFTOFF W/STME OUT
COMPOSITE NX+ SHEAR LOADS VS X-STATION**

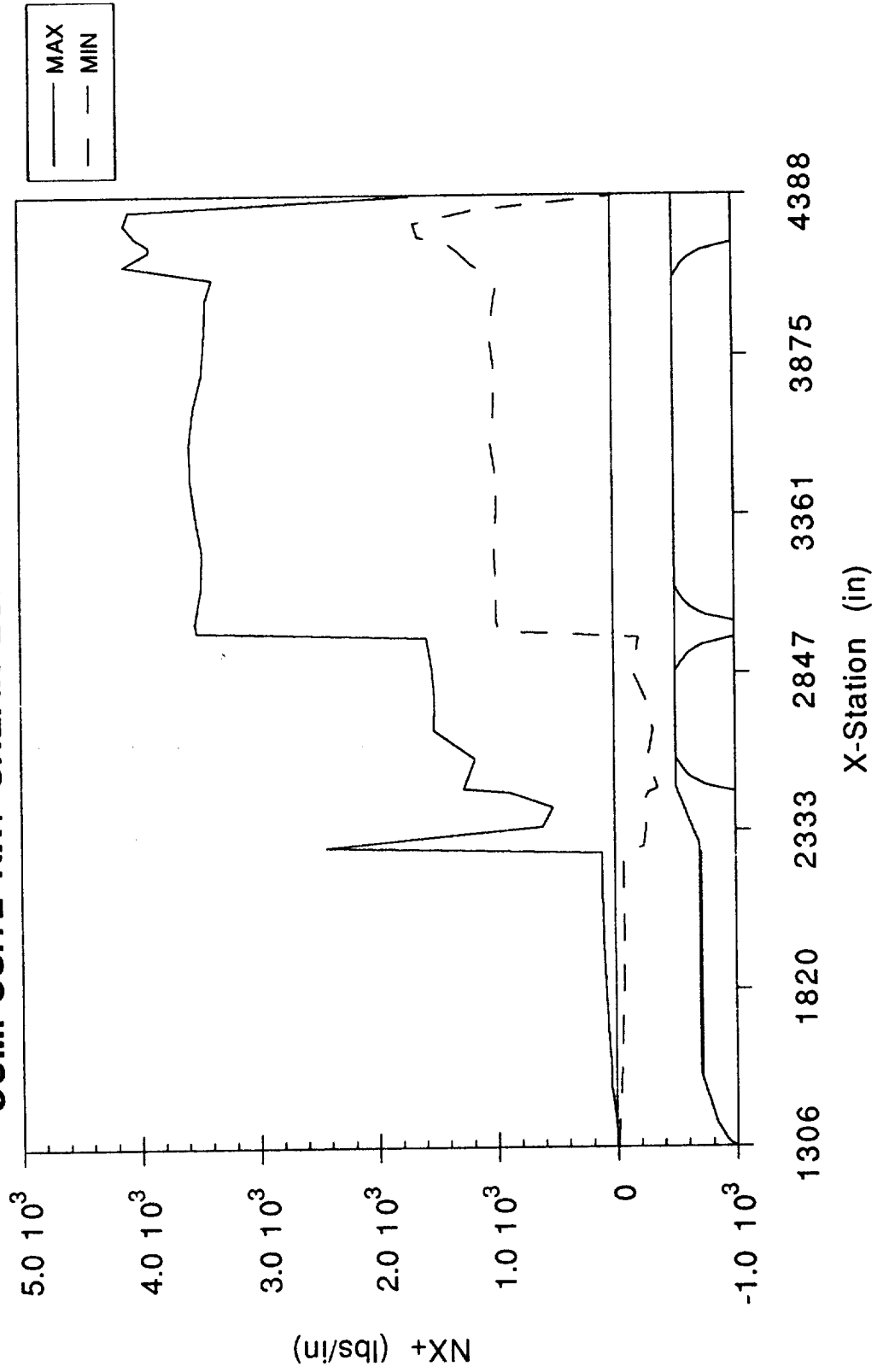

**NLS2 LIFTOFF W/STME OUT
COMPOSITE NX- SHEAR LOADS VS X-STATION**

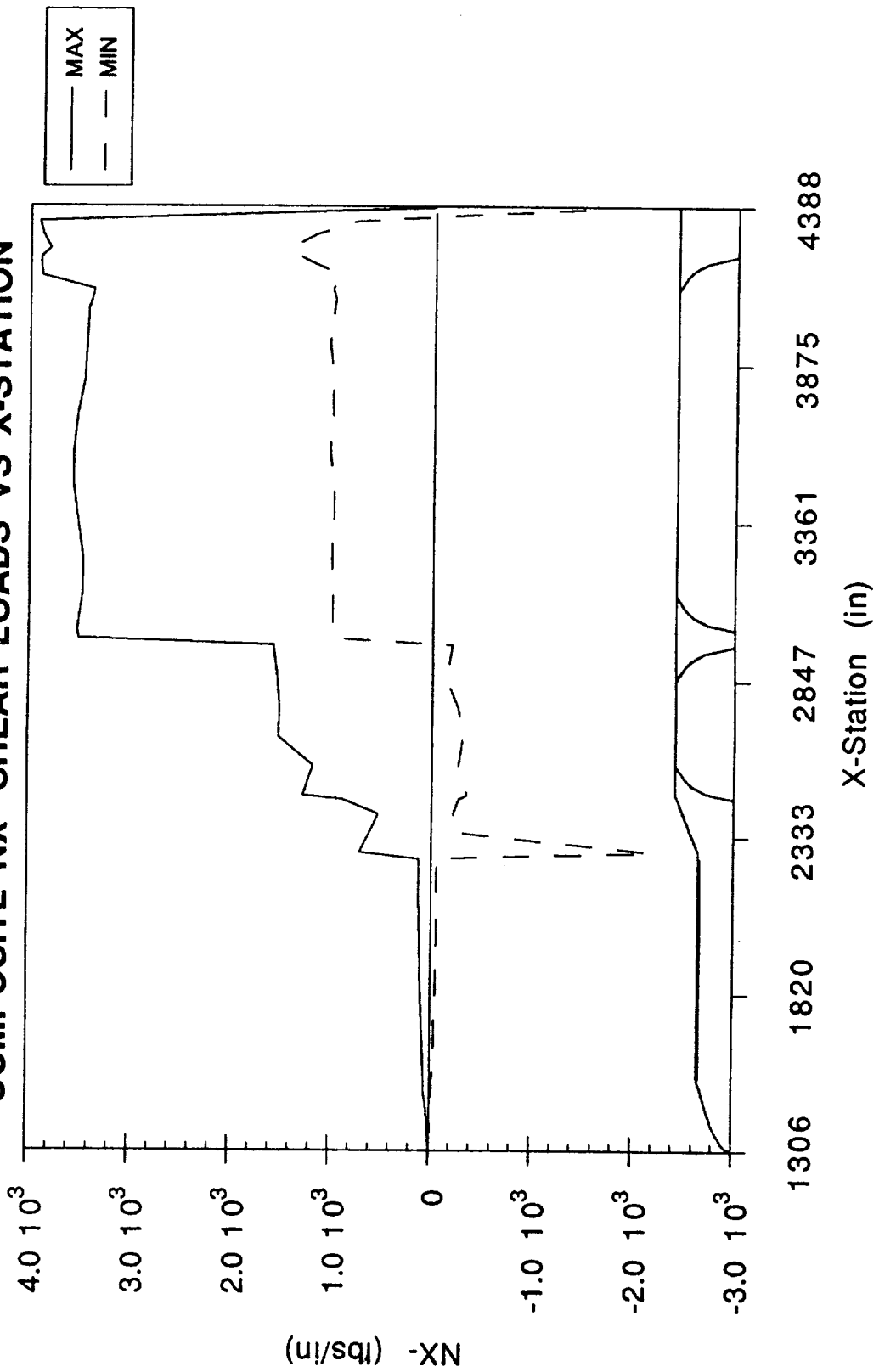

NLS2 COMPOSITE SHEAR BODY LOADS W/O STME OUT (LBS)

LIFTOFF

X-Station (in)	X-Dir.		X-Dir.		Y-Dir.		Y-Dir.		Z-Dir.	
	Maximum	Minimum	Maximum	Minimum	Maximum	Minimum	Maximum	Minimum	Maximum	Minimum
1306.1	260.2	-158.7	296.8	-307.3	303.4	-188.8				
1395.1	4161	-2537	4171	-4306	3483	-1870				
1444.9	11250	-6854	10690	-10990	8893	-4136				
1494.6	24970	-15180	22380	-22880	18540	-8581				
1544.4	33850	-20530	29470	-30030	24420	-11240				
1624.4	42100	-25400	35440	-35900	29660	-13400				
1704.4	49570	-29690	40310	-40530	34400	-15100				
1784.4	56130	-33280	44110	-44000	38500	-16470				
1864.4	61680	-36100	46930	-46430	41960	-17720				
1944.4	66140	-38080	49420	-47940	44820	-18810				
2024.4	69480	-39200	52050	-48710	47150	-19880				
2104.4	71880	-40220	54310	-48890	49080	-22860				
2184.4	73310	-40470	56700	-48880	50800	-29990				
2264.4	73710	-39940	59430	-49050	52600	-38440				
2284.8	461300	-192200	159600	-139200	195000	-211100				
2347.8	462000	-192900	161400	-138600	204500	-222400				
2410.8	461700	-193200	162400	-137900	209100	-228000				
2459.2	862900	-264000	404600	-465300	335200	-364600				
2471.1	1271000	-351900	612500	-621500	493500	-376300				
2569.8	1227000	-280900	461400	-429500	454300	-375000				
2664.1	1586000	-323600	711300	-415000	559300	-318200				
2758.5	1576000	-270900	492300	-387400	509400	-325500				
2852.8	1600000	-151200	634100	-502500	473100	-447000				
2963.4	1645000	-208700	370800	-312800	325200	-230700				
2985.7	3657000	1012000	370500	-320800	327700	-233300				
3012.5	3672000	1031000	375900	-367100	333200	-239500				
3123.1	3622000	1031000	267800	-267900	206400	-203100				
3240	3608000	1049000	272800	-265400	245900	-214500				
3356.9	3661000	1032000	245800	-285000	190400	-192000				
3473.7	3708000	1024000	227400	-202100	212400	-171800				
3590.6	3715000	1071000	184300	-236700	145100	-234500				
3707.4	3677000	1044000	150100	-225900	158800	-237500				
3824.3	3601000	1038000	121200	-317900	117600	-266200				
3941.1	3580000	1073000	156100	-309700	123000	-335800				
4058	3562000	1035000	245600	-358000	137000	-377100				
4090.3	3532000	1017000	298100	-473800	173500	-426100				
4122.6	3506000	1054000	312500	-522500	205100	-454300				
4166.6	4066000	1233000	297700	-319700	213200	-286800				
4210.3	4058000	1361000	270400	-317200	195400	-273900				
4227.4	4051000	1421000	263000	-325000	192600	-269500				
4254	3968000	1692000	193800	-276700	181300	-345100				
4297.8	4060000	1712000	162100	-333300	188200	-311100				
4341.6	4091000	1169000	200600	-311800	187800	-267800				
4385.5	3939	-0.1894	0.3714	-703.1	0.8306	-2389				

NLS2 COMPOSITE MOMENT BODY LOADS W/O STME OUT (IN-LBS)

LIFTOFF

X-Station (in)	X-Dir.		Y-Dir.		Y-Dir.		Z-Dir.	
	Maximum	Minimum	Maximum	Minimum	Maximum	Minimum	Maximum	Minimum
1306.1	1722	-1545	2.221	0.0005961	0.0006276	-6.266		
1395.1	12610	-11310	27020	-16810	26430	-27360		
1444.9	26920	-24140	195400	-109900	233800	-241700		
1494.6	57590	-51650	638100	-297400	765800	-788500		
1544.4	320600	-287500	1561000	-724200	1880000	-1927000		
1624.4	473500	-424400	3509000	-1623000	4237000	-4330000		
1704.4	548600	-491300	5860000	-2695000	7069000	-7201000		
1784.4	578600	-517800	8581000	-3903000	10290000	-10440000		
1864.4	589100	-527000	11650000	-5215000	13820000	-13960000		
1944.4	595400	-532400	15000000	-6602000	17580000	-17680000		
2024.4	601700	-537300	18590000	-8049000	21490000	-21510000		
2104.4	601100	-538400	22360000	-9577000	25490000	-25410000		
2184.4	576500	-547600	26290000	-11210000	29550000	-29320000		
2264.4	506400	-529900	30350000	-12890000	33700000	-33220000		
2284.8	1349000	-1381000	65380000	-47280000	68160000	-58650000		
2347.8	1325000	-1396000	69010000	-51570000	77640000	-66930000		
2410.8	1267000	-1398000	73610000	-55910000	87160000	-75110000		
2459.2	1152000	-1414000	81360000	-59190000	94520000	-81320000		
2471.1	1190000	-1424000	82380000	-58820000	94140000	-80590000		
2569.8	1201000	-1409000	77840000	-70990000	95010000	-75800000		
2664.1	1201000	-1411000	76970000	-67790000	84230000	-76230000		
2758.5	1197000	-1434000	74880000	-49490000	91560000	-79440000		
2852.8	1156000	-1531000	91260000	-56040000	102700000	-59460000		
2963.4	1094000	-1625000	86530000	-53870000	101900000	-59700000		
2985.7	1094000	-1625000	82990000	-53400000	94980000	-58330000		
3012.5	3194000	-2902000	78970000	-53720000	86360000	-56740000		
3123.1	1714000	-2563000	65770000	-51770000	65350000	-51890000		
3240	2474000	-2789000	73650000	-53640000	74090000	-51680000		
3356.9	1890000	-2915000	70580000	-59810000	73870000	-54040000		
3473.7	1348000	-2978000	85400000	-61010000	88210000	-68350000		
3590.6	1360000	-3014000	85210000	-64510000	89010000	-75640000		
3707.4	1374000	-3057000	94210000	-66060000	94310000	-74340000		
3824.3	1929000	-3144000	103300000	-63520000	90200000	-66960000		
3941.1	2912000	-3310000	112400000	-59120000	94330000	-58880000		
4058	4441000	-4628000	121500000	-51000000	97640000	-54770000		
4090.3	4733000	-5031000	124000000	-50460000	101900000	-53100000		
4122.6	4326000	-5066000	126400000	-50700000	106900000	-50590000		
4166.6	4007000	-4960000	130100000	-48350000	111500000	-55160000		
4210.3	4195000	-5051000	133200000	-46020000	109000000	-52790000		
4227.4	4470000	-5090000	134400000	-44280000	106600000	-52690000		
4254	5417000	-6479000	136200000	-53160000	98850000	-53420000		
4297.8	7504000	-5543000	139100000	-79100000	102000000	-71620000		
4341.6	7995000	-5889000	142300000	-95070000	105000000	-91810000		
4385.5	49490	-24.93	14940000	-16520000	16740000	-19210000		

NLS2 COMPOSITE LINE BODY LOADS W/O STME OUT

LIFTOFF

X-Station (in)	NX+ (lbs/in)		NX- (lbs/in)		NX- (lbs/in)		PEQ+ (lbs)		PEQ- (lbs)	
	Maximum	Minimum	Maximum	Minimum	Maximum	Minimum	Maximum	Minimum	Maximum	Minimum
1306.1	0	0	0	0	0	0	0	0	0	0
1395.1	18.92	-11.54	18.92	-11.54	18.92	-11.54	4161	-2537	4161	-2537
1444.9	29.84	-18.18	29.84	-18.18	29.84	-18.18	11250	-6854	11250	-6854
1494.6	49.67	-30.2	49.67	-30.2	49.67	-30.2	24970	-15180	24970	-15180
1544.4	53.88	-32.68	53.88	-32.68	53.88	-32.68	33850	-20530	33850	-20530
1624.4	67.01	-40.43	67.01	-40.43	67.01	-40.43	42100	-25400	42100	-25400
1704.4	78.89	-47.25	78.89	-47.25	78.89	-47.25	49570	-29690	49570	-29690
1784.4	89.33	-52.96	89.33	-52.96	89.33	-52.96	56130	-33280	56130	-33280
1864.4	98.16	-57.45	98.16	-57.45	98.16	-57.45	61680	-36100	61680	-36100
1944.4	105.3	-60.61	105.3	-60.61	105.3	-60.61	66140	-38080	66140	-38080
2024.4	110.6	-62.38	110.6	-62.38	110.6	-62.38	69480	-39200	69480	-39200
2104.4	114.4	-64.01	114.4	-64.01	114.4	-64.01	71880	-40220	71880	-40220
2184.4	116.7	-64.4	116.7	-64.4	116.7	-64.4	73310	-40470	73310	-40470
2264.4	117.3	-63.56	117.3	-63.56	117.3	-63.56	73710	-39940	73710	-39940
2284.8	2440	-194.2	710.8	-2179	710.8	-2179	1533000	-122000	446600	-1369000
2347.8	614.3	-256.5	614.3	-256.5	614.3	-256.5	462000	-192900	462000	-192900
2410.8	527.1	-220.6	527.1	-220.6	527.1	-220.6	461700	-193200	461700	-193200
2459.2	888.9	-271.9	888.9	-271.9	888.9	-271.9	862900	-264000	862900	-264000
2471.1	1278	-353.8	1278	-353.8	1278	-353.8	1271000	-351900	1271000	-351900
2569.8	1180	-270.1	1180	-270.1	1180	-270.1	1227000	-280900	1227000	-280900
2664.1	1525	-311.2	1525	-311.2	1525	-311.2	1586000	-323600	1586000	-323600
2758.5	1516	-260.5	1516	-260.5	1516	-260.5	1576000	-270900	1576000	-270900
2852.8	1538	-145.4	1538	-145.4	1538	-145.4	1600000	-151200	1600000	-151200
2963.4	1582	-200.7	1582	-200.7	1582	-200.7	1645000	-208700	1645000	-208700
2985.7	3517	973.2	3517	973.2	3517	973.2	3657000	1012000	3657000	1012000
3012.5	3531	991.7	3531	991.7	3531	991.7	3672000	1031000	3672000	1031000
3123.1	3483	991.5	3483	991.5	3483	991.5	3622000	1031000	3622000	1031000
3240	3469	1009	3469	1009	3469	1009	3608000	1049000	3608000	1049000
3356.9	3521	992.3	3521	992.3	3521	992.3	3661000	1032000	3661000	1032000
3473.7	3566	984.9	3566	984.9	3566	984.9	3708000	1024000	3708000	1024000
3590.6	3573	1030	3573	1030	3573	1030	3715000	1071000	3715000	1071000
3707.4	3536	1004	3536	1004	3536	1004	3677000	1044000	3677000	1044000
3824.3	3463	998.4	3463	998.4	3463	998.4	3601000	1038000	3601000	1038000
3941.1	3443	1032	3443	1032	3443	1032	3580000	1073000	3580000	1073000
4058	3425	995.7	3425	995.7	3425	995.7	3562000	1035000	3562000	1035000
4090.3	3397	978.2	3397	978.2	3397	978.2	3532000	1017000	3532000	1017000
4122.6	3372	1013	3372	1013	3372	1013	3506000	1054000	3506000	1054000
4166.6	4114	1188	3884	927.2	3884	927.2	4278000	1236000	4039000	964200
4210.3	3904	1313	3900	1227	3900	1227	4060000	1365000	4056000	1276000
4227.4	3896	1369	3896	1328	3896	1328	4052000	1423000	4051000	1381000
4254	4013	1633	3806	1447	3806	1447	4173000	1698000	3958000	1504000
4297.8	4113	1671	3882	1186	3882	1186	4277000	1737000	4036000	1233000
4341.6	4071	1151	3912	773.1	3912	773.1	4234000	1197000	4067000	804000
4385.5	1705	0.2368	0.177	-1705	0.177	-1705	1773000	246.2	184	-1773000

NLS2 LIFTOFF W/O STME OUT COMPOSITE AXIAL SHEAR LOADS VS X-STATION

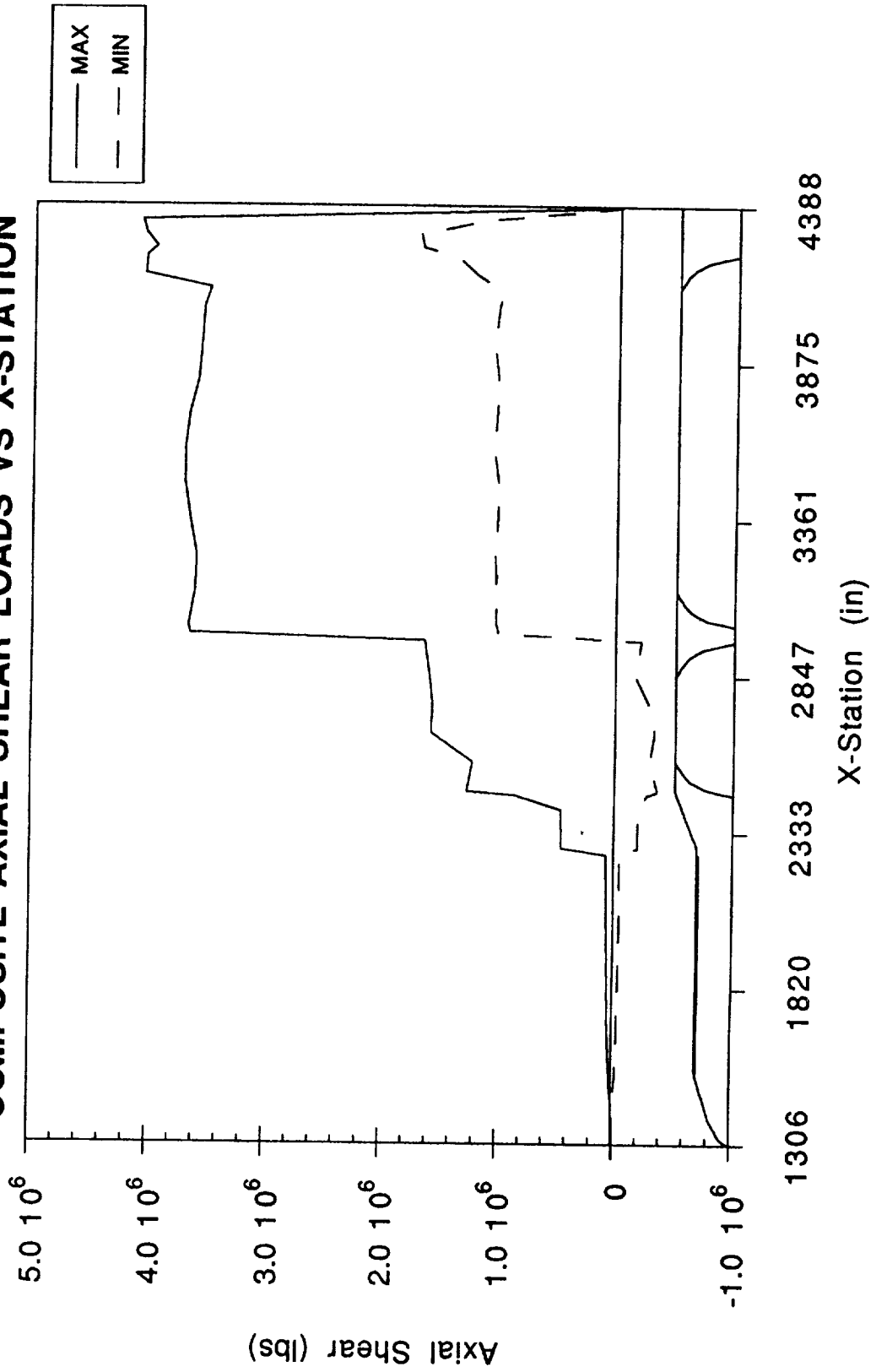

(

(

(

**NLS2 LIFTOFF W/O STME OUT
COMPOSITE Y-DIR SHEAR LOADS VS X-STATION**

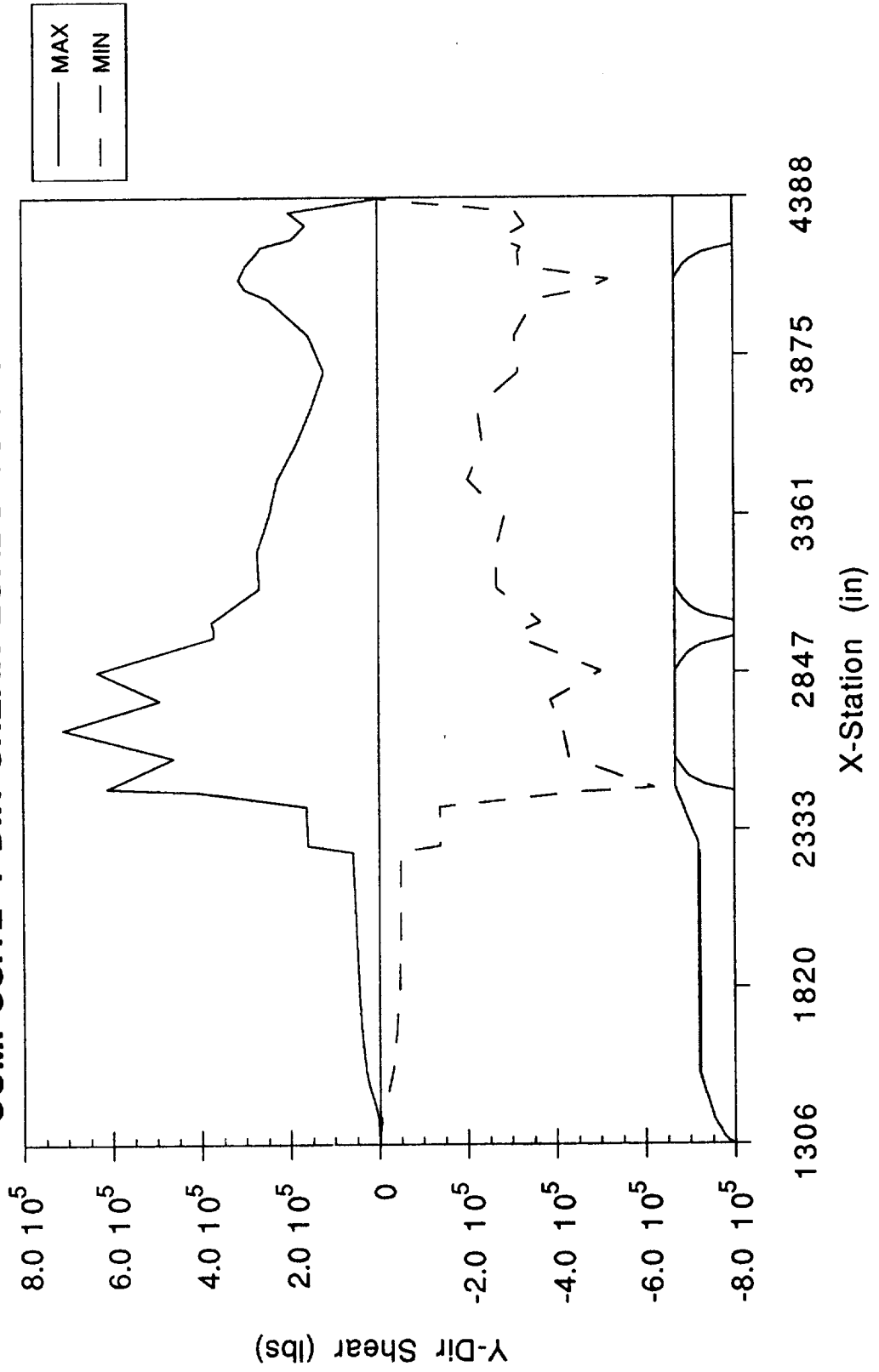

NLS2 LIFTOFF W/O STME OUT COMPOSITE Z-DIR SHEAR LOADS VS X-STATION

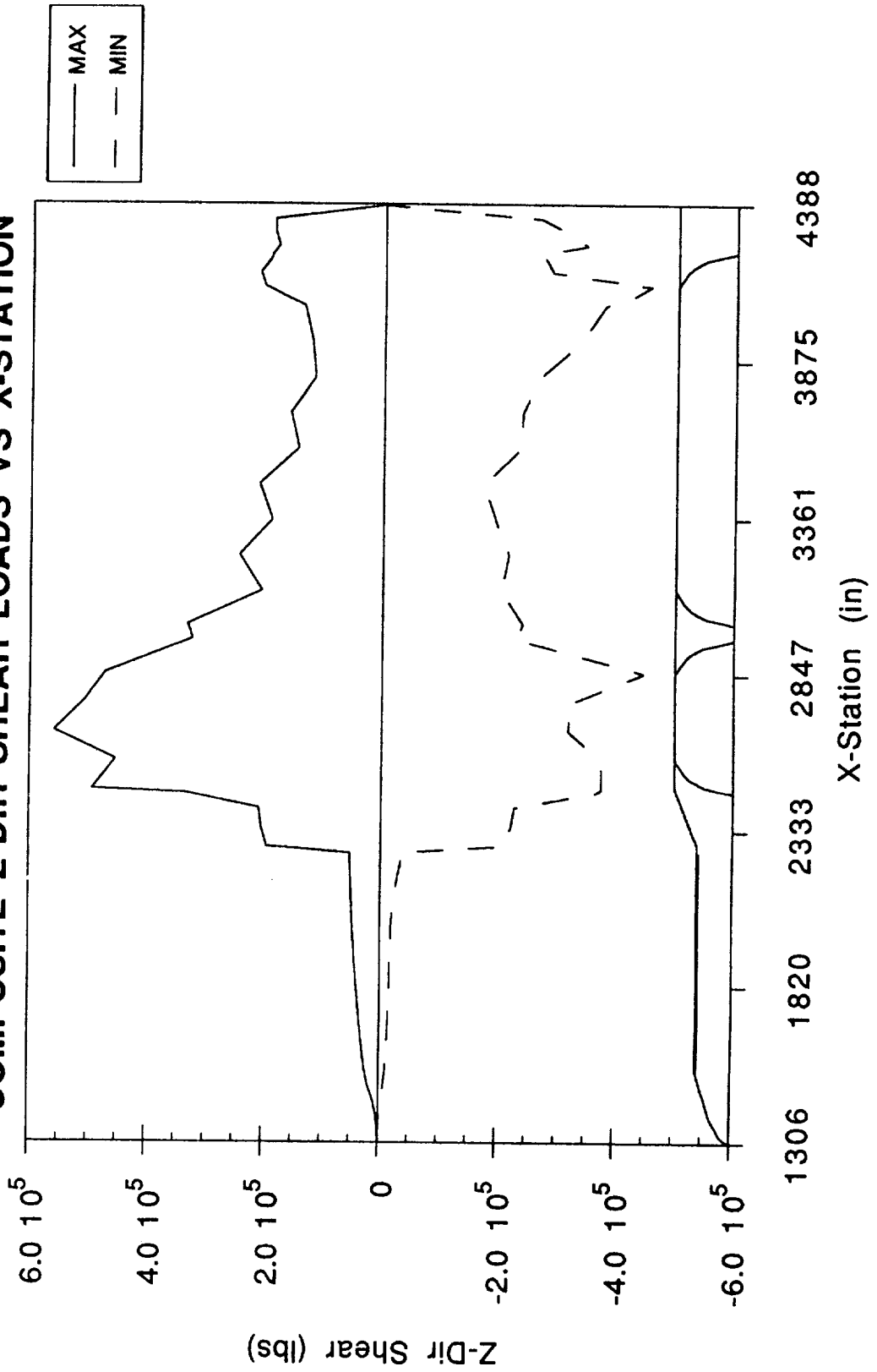

(((

NLS2 LIFTOFF W/O STME OUT COMPOSITE X-DIR TORSION VS X-STATION

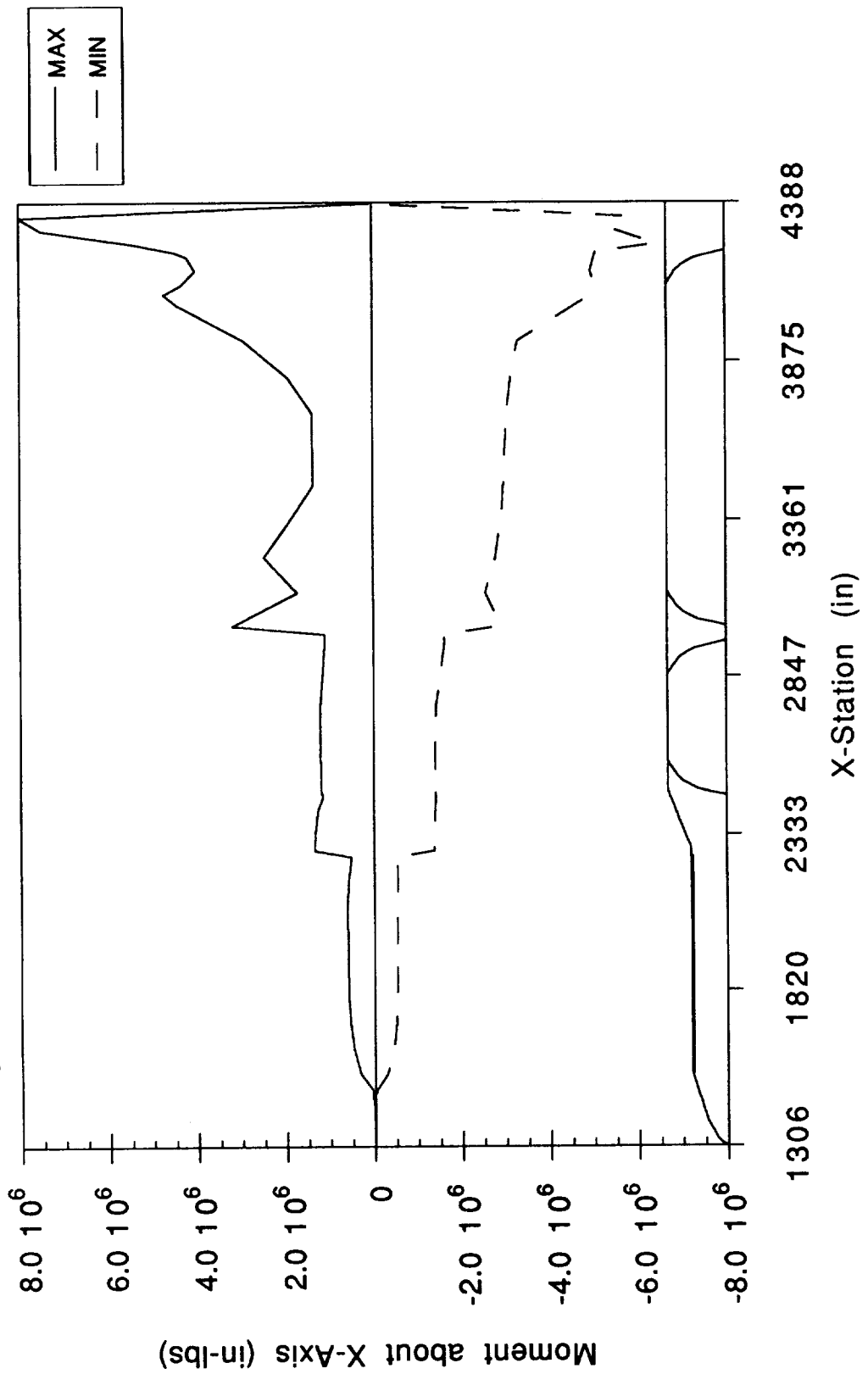

NLS2 LIFTOFF W/O STME OUT COMPOSITE Y-DIR MOMENT VS X-STATION

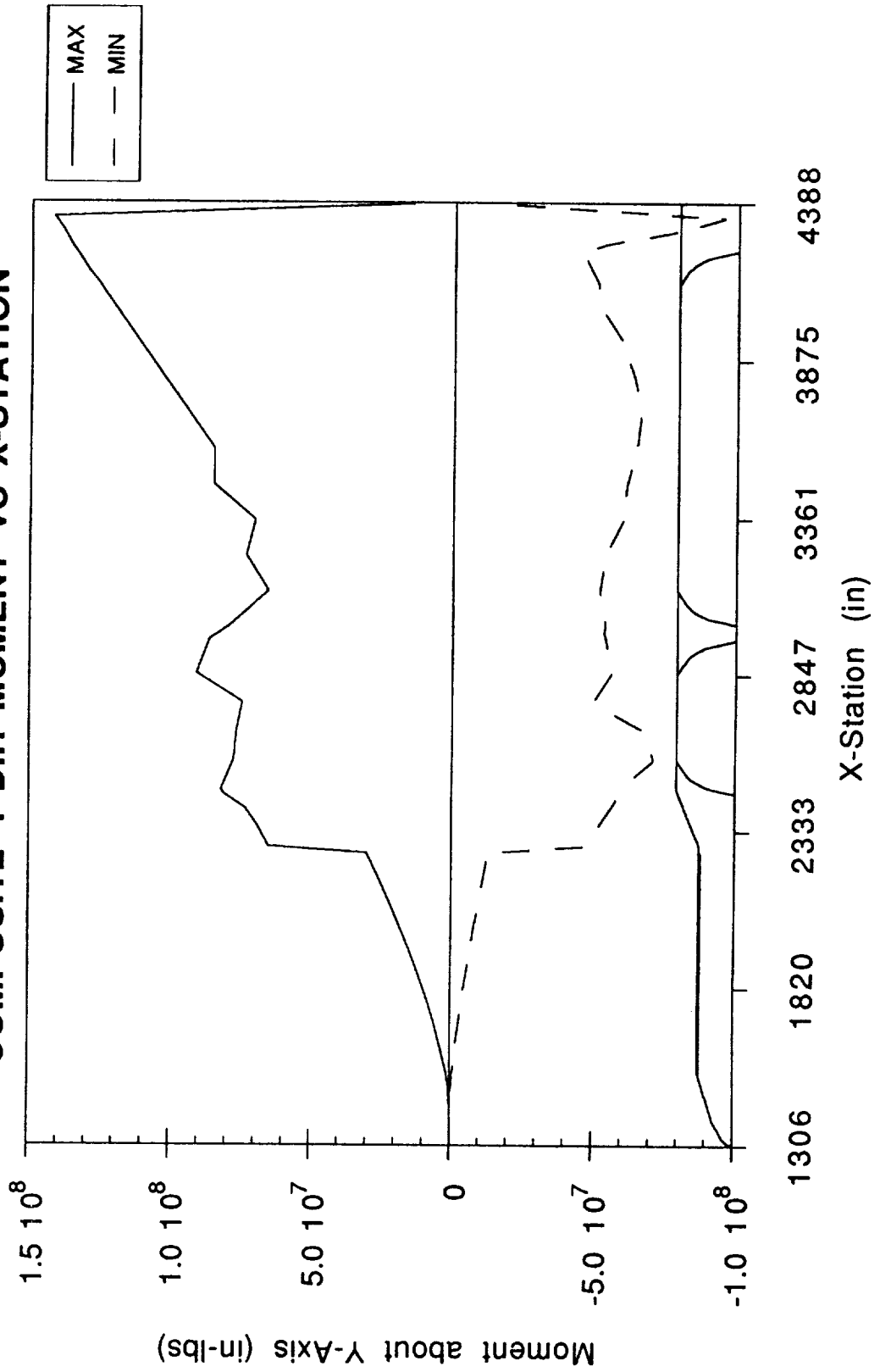

(((

NLS2 LIFTOFF W/O STME OUT COMPOSITE Z-DIR MOMENT VS X-STATION

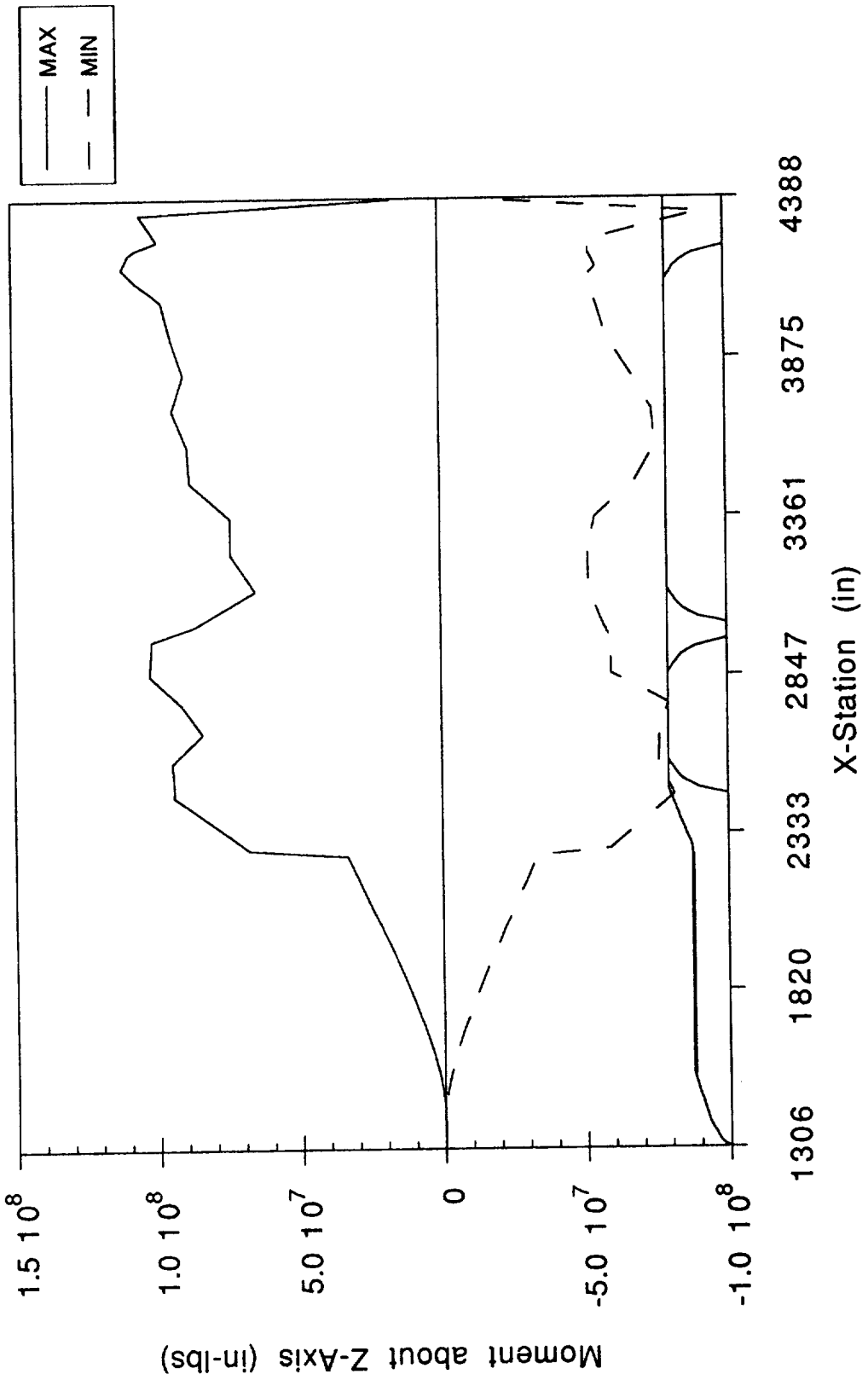

NLS2 LIFTOFF W/O STME OUT COMPOSITE NX+ LOADS VS X-STATION

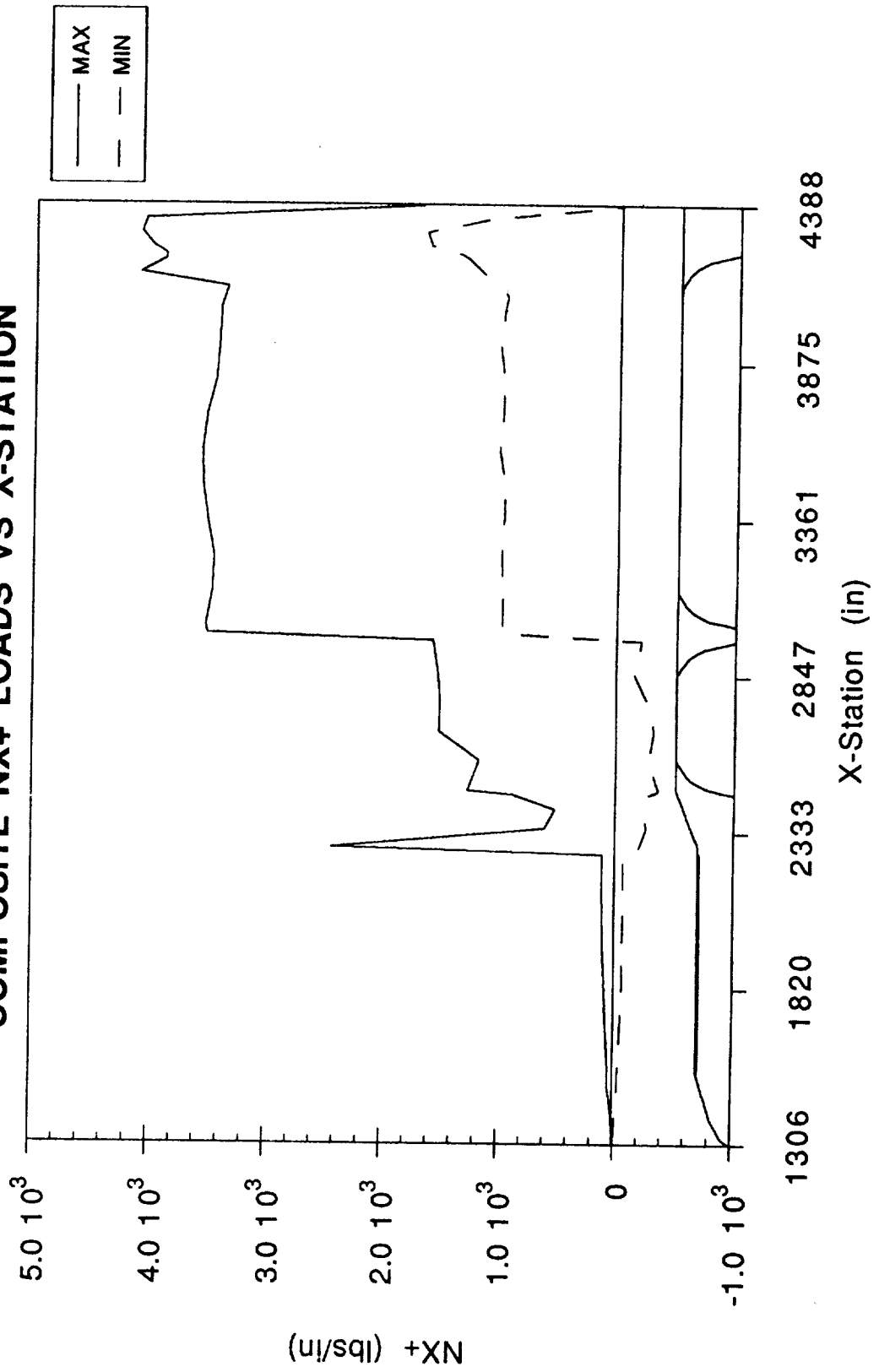

(((

**NLS2 LIFTOFF W/O STME OUT
COMPOSITE NX- LOADS VS X-STATION**

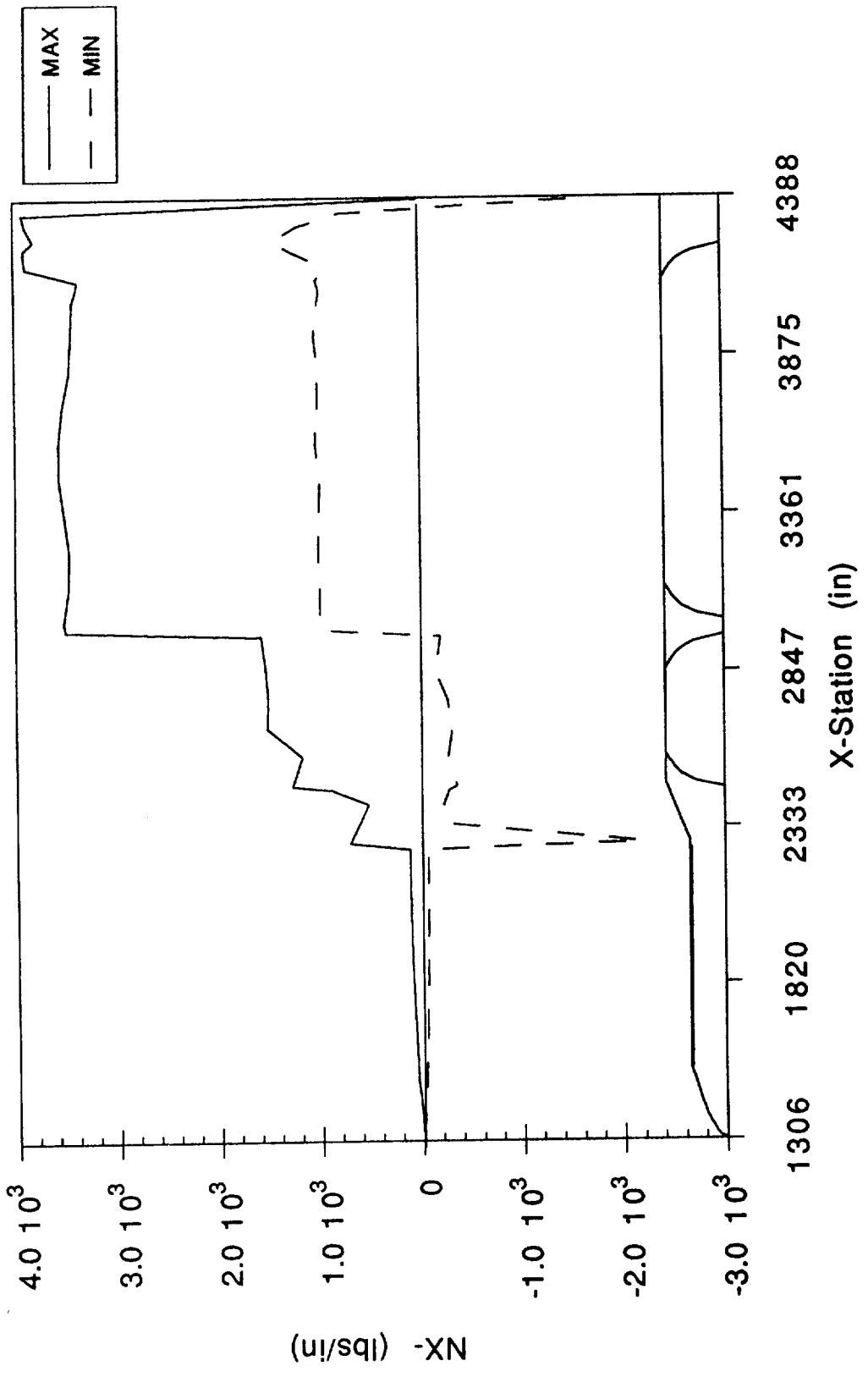

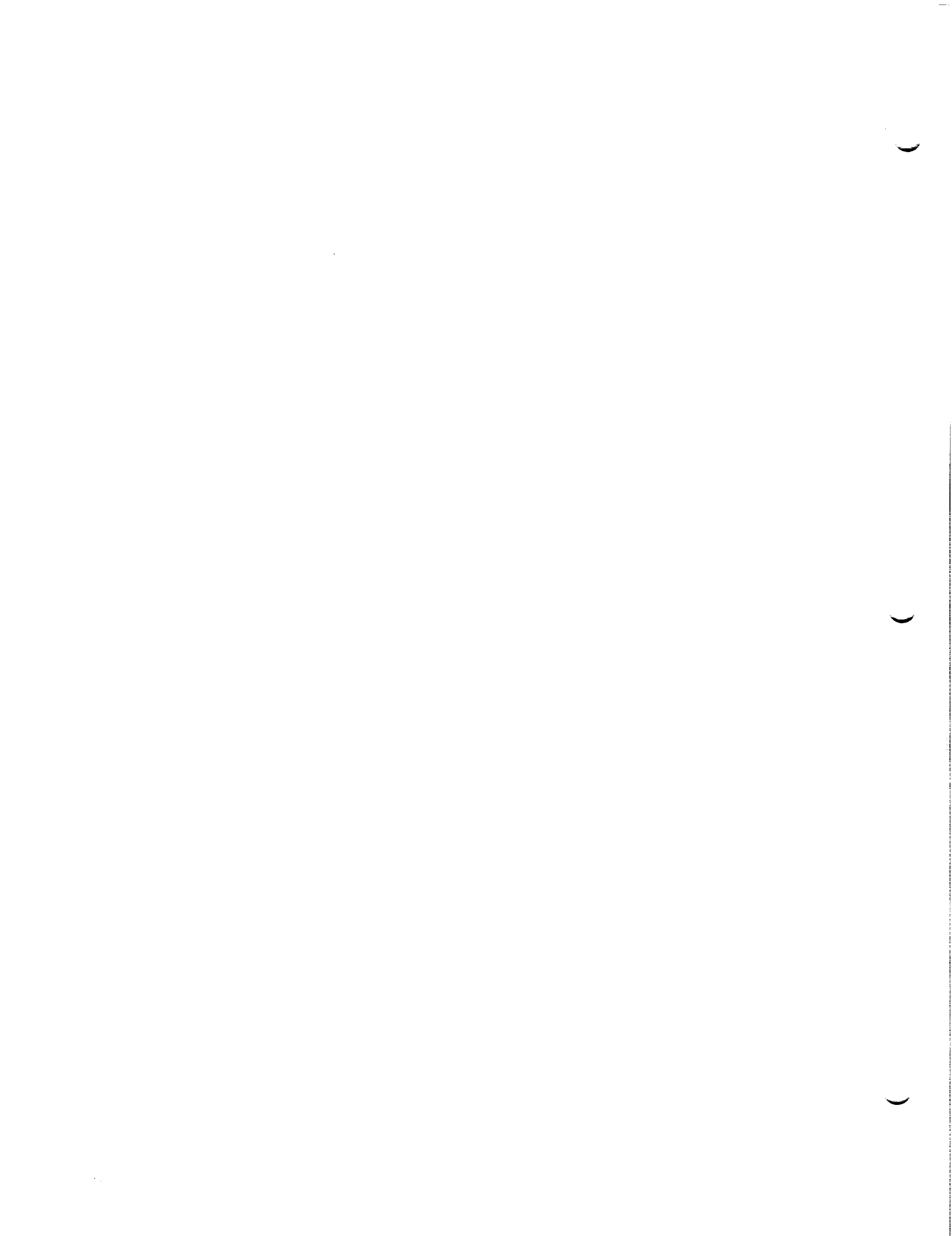

NLS 1 AND NLS 2
PRELAUNCH AND LIFTOFF
LINE LOAD COMPARISONS

**NLS1 W/STME OUT
NX MAX-MIN COMPARISON VS X-STATION**

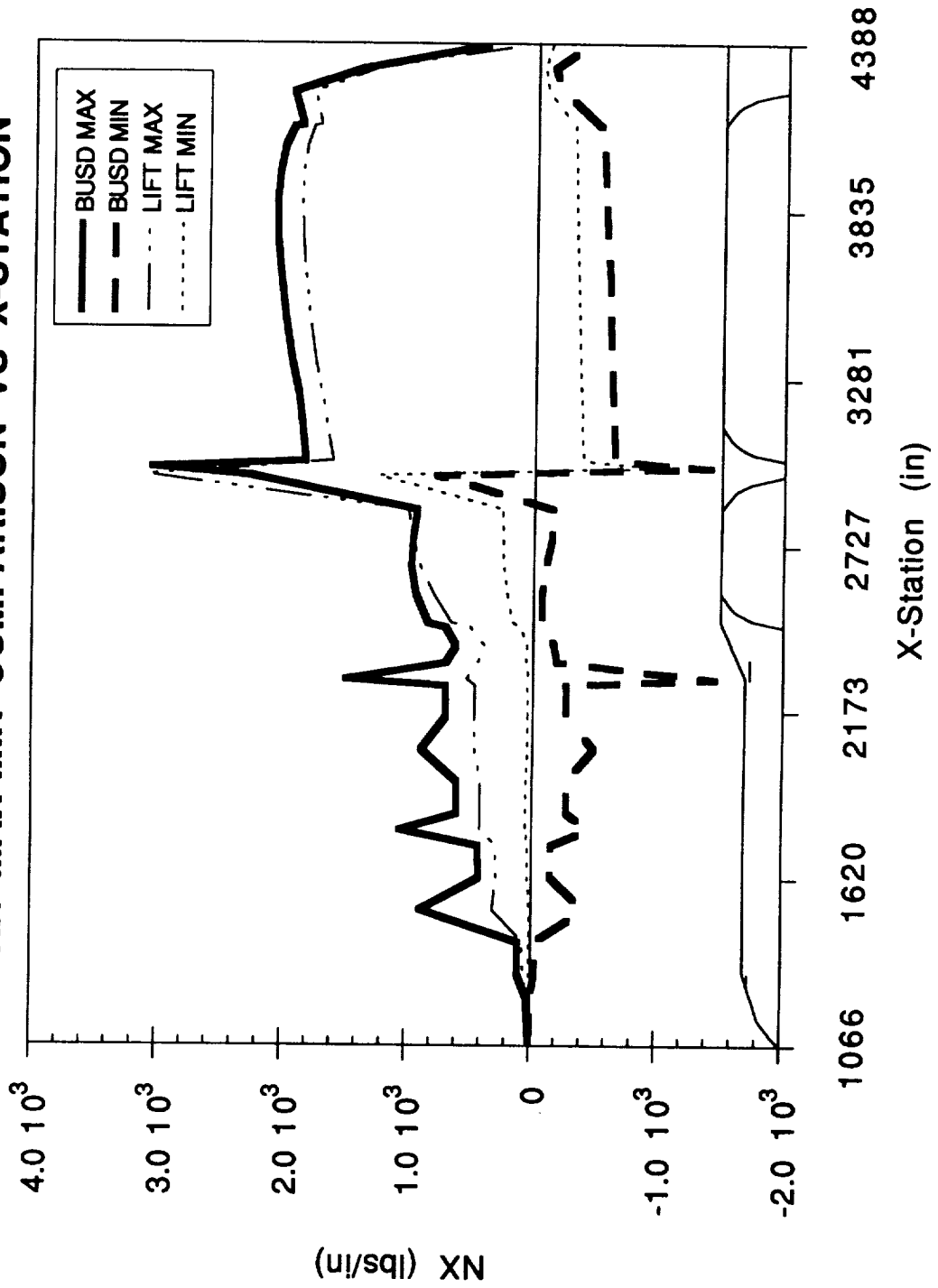

**NLS1 W/O STME OUT
NX MAX-MIN COMPARISON VS X-STATION**

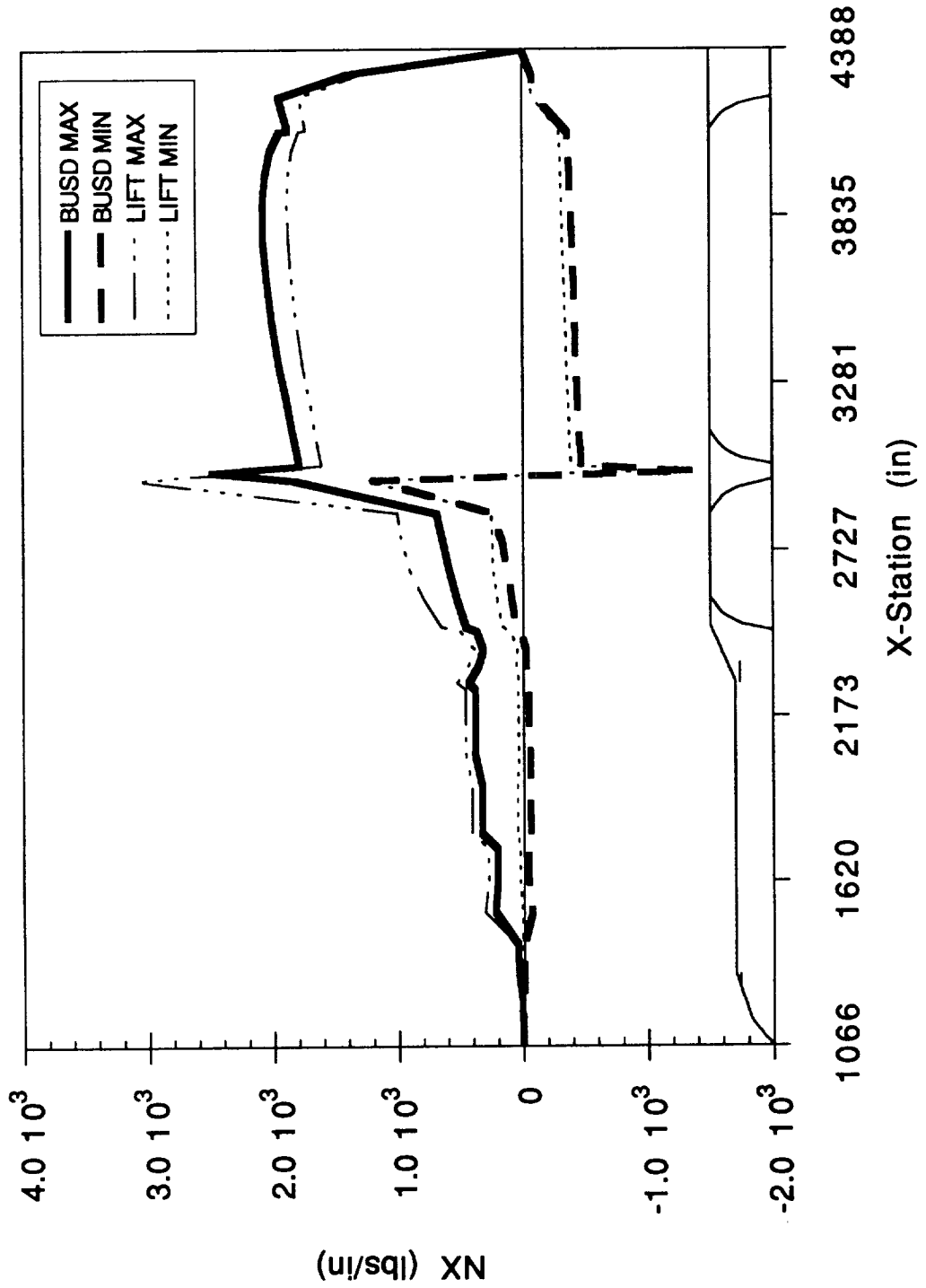

NLS2 W/STME OUT NX MAX-MIN COMPARISON VS X-STATION

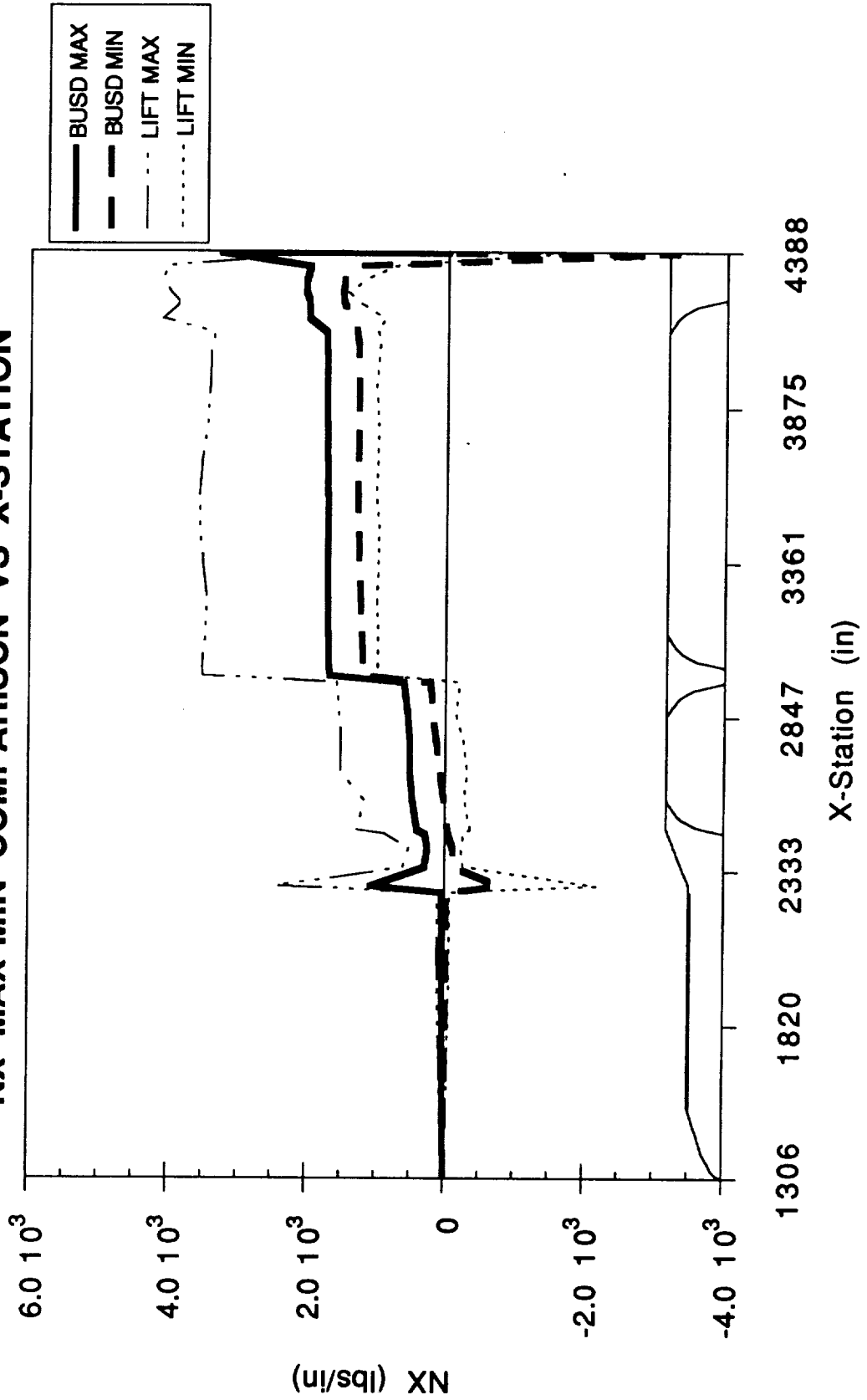

() ()

**NLS2 W/O STME OUT
NX MAX-MIN COMPARISON VS X-STATION**

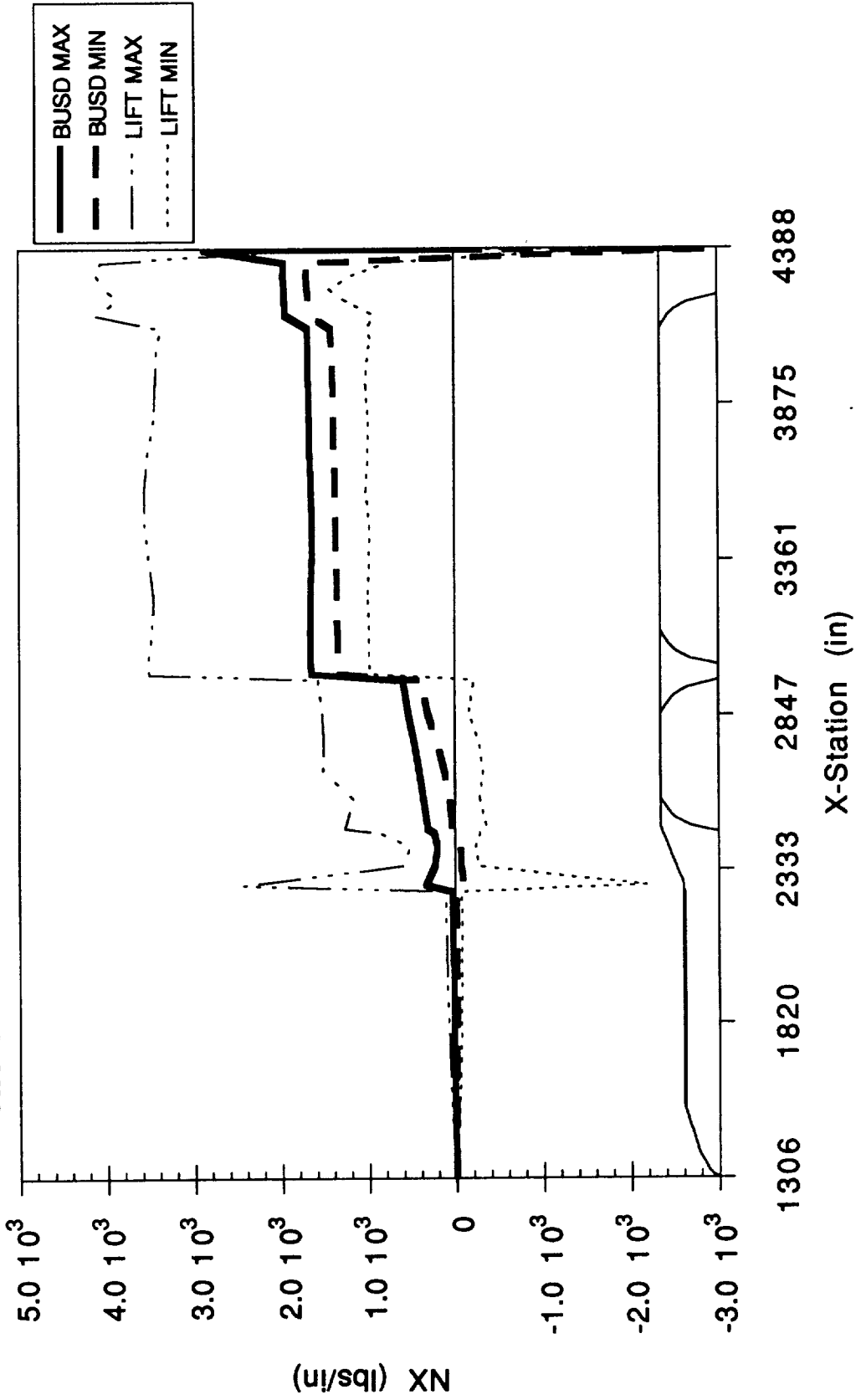

**NX COMPARISONS VS X-STATION
NLS1/NLS2 COMPOSITE W/STME OUT**

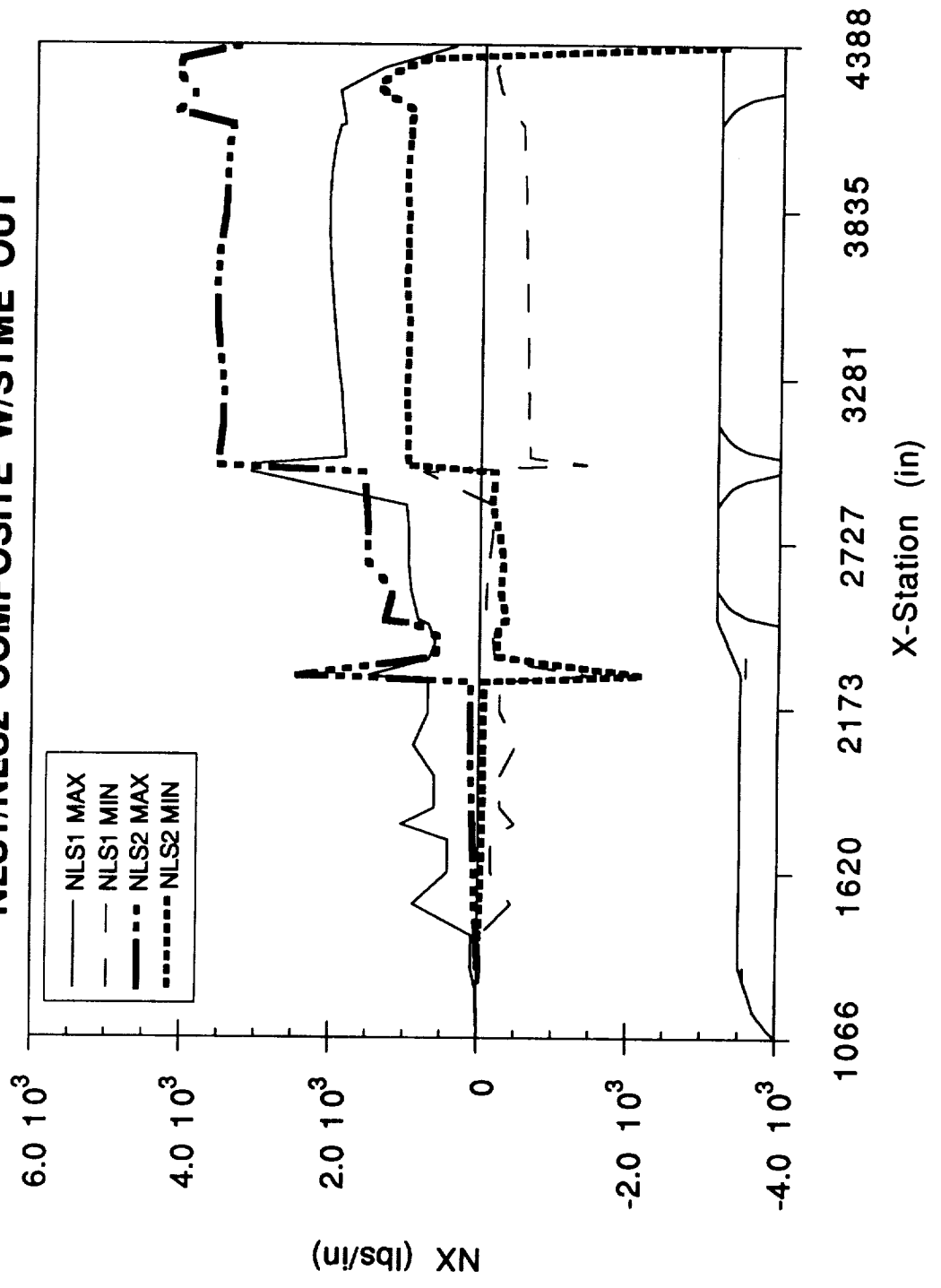

**NX COMPARISONS VS X-STATION
NLS1/NLS2 COMPOSITE W/O STME OUT**

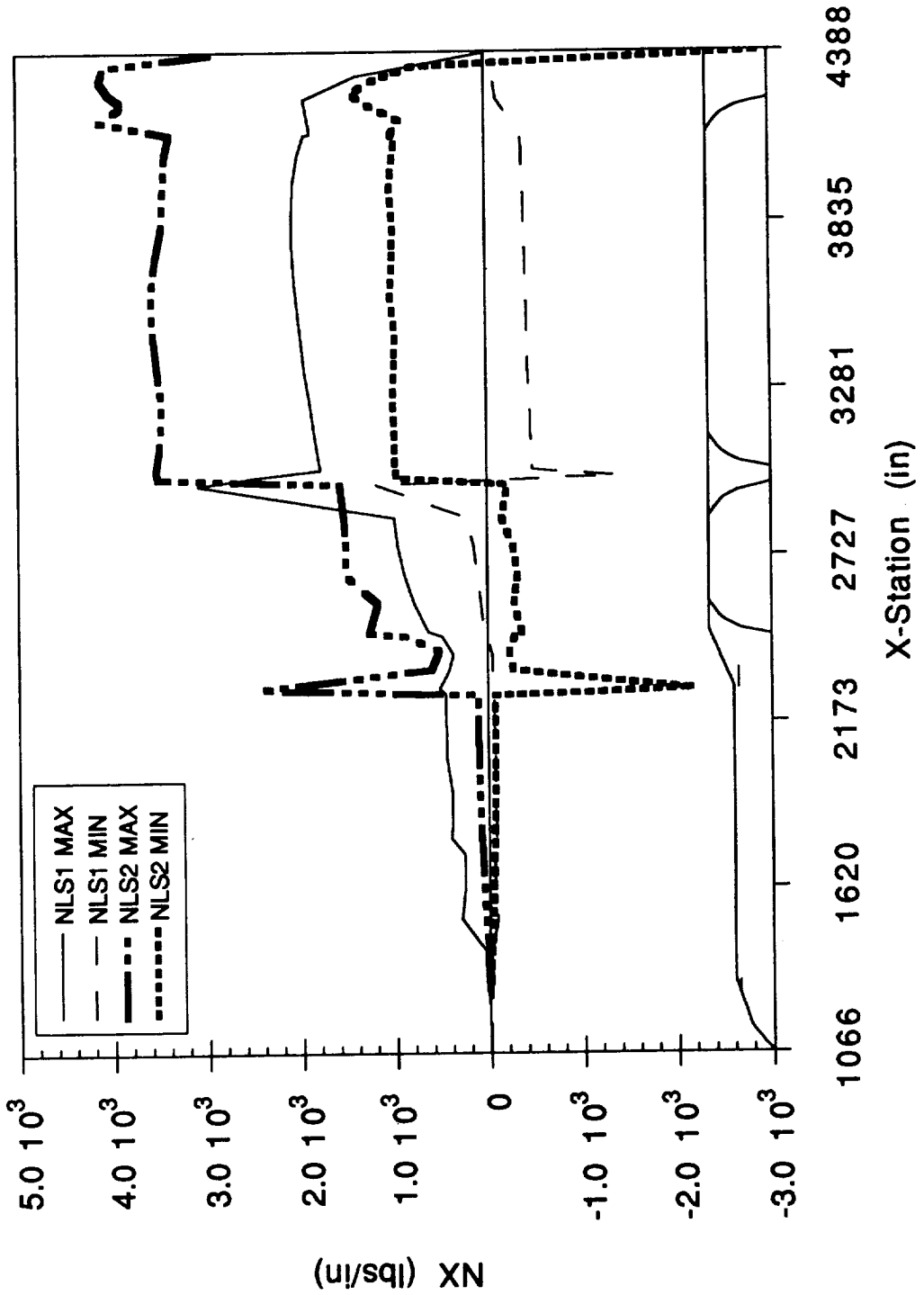

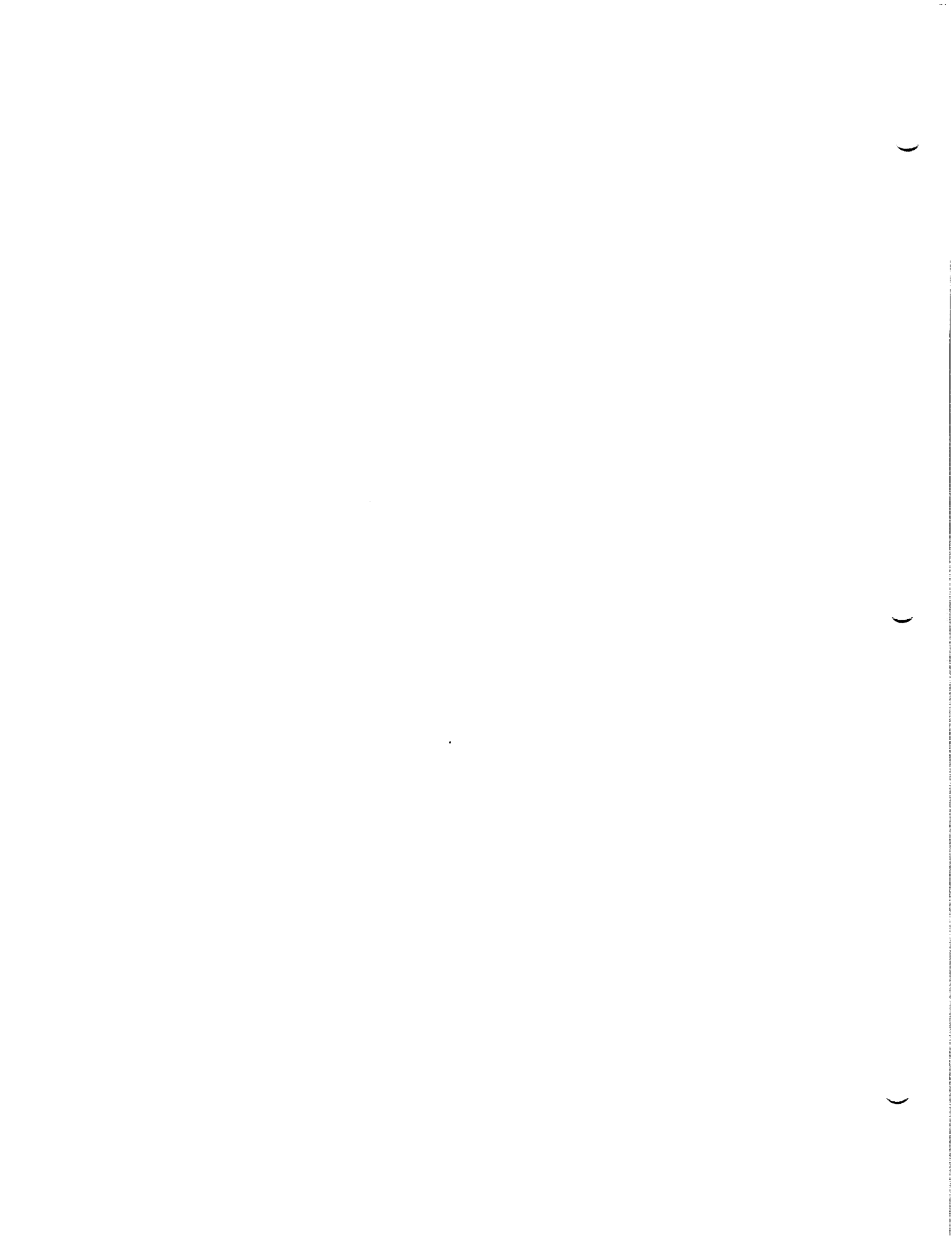

NLS 1 AND NLS 2
OVERALL
LINE LOAD COMPARISONS

**NLS1 W/O STME OUT
NX EVENT COMPARISON VS X-STATION**

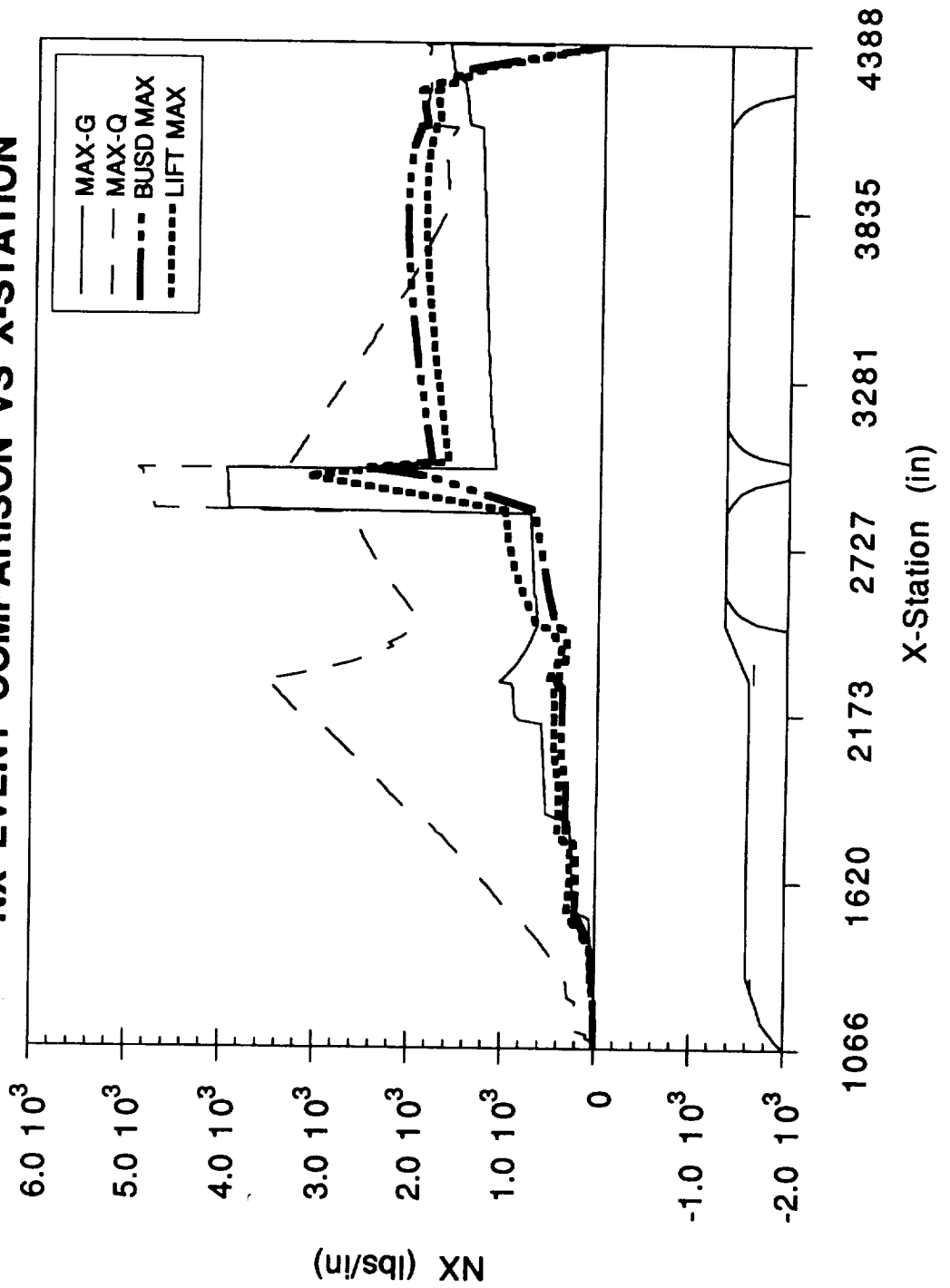

**NLS2 W/STME OUT
NX EVENT COMPARISON VS X-STATION**

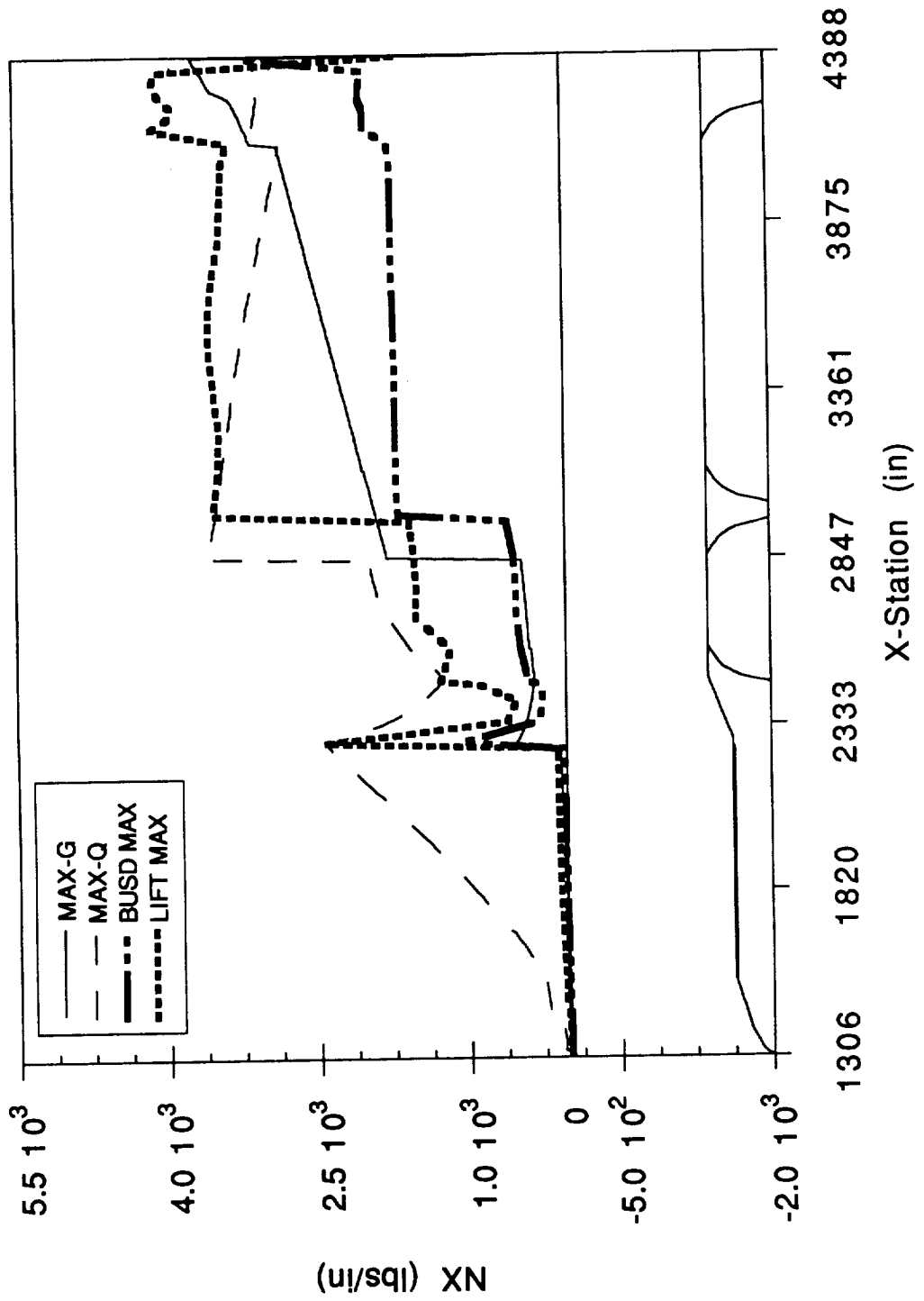

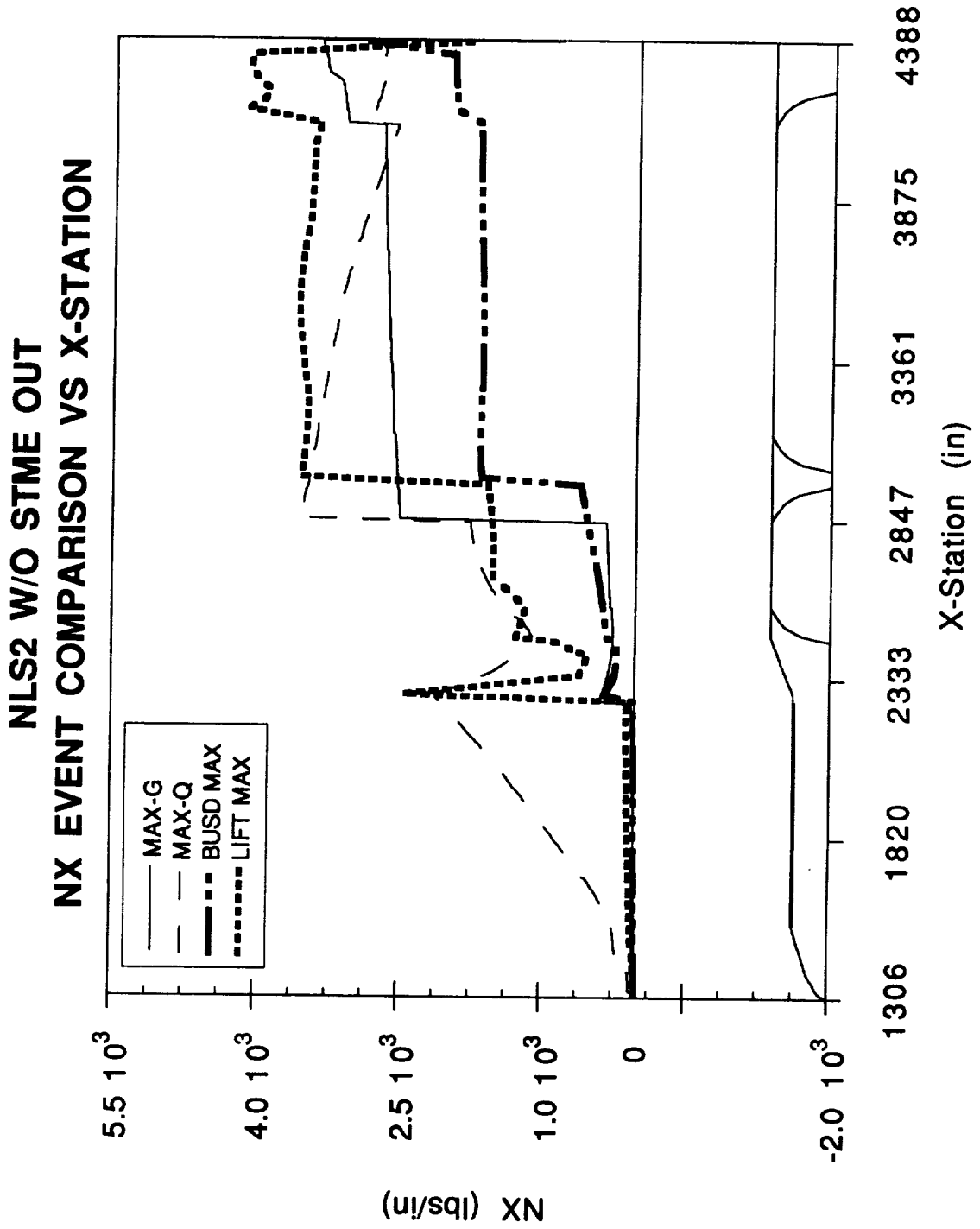

(((((

**NLS1 AND NLS2 W/STME OUT
NX EVENT COMPARISON VS X-STATION**

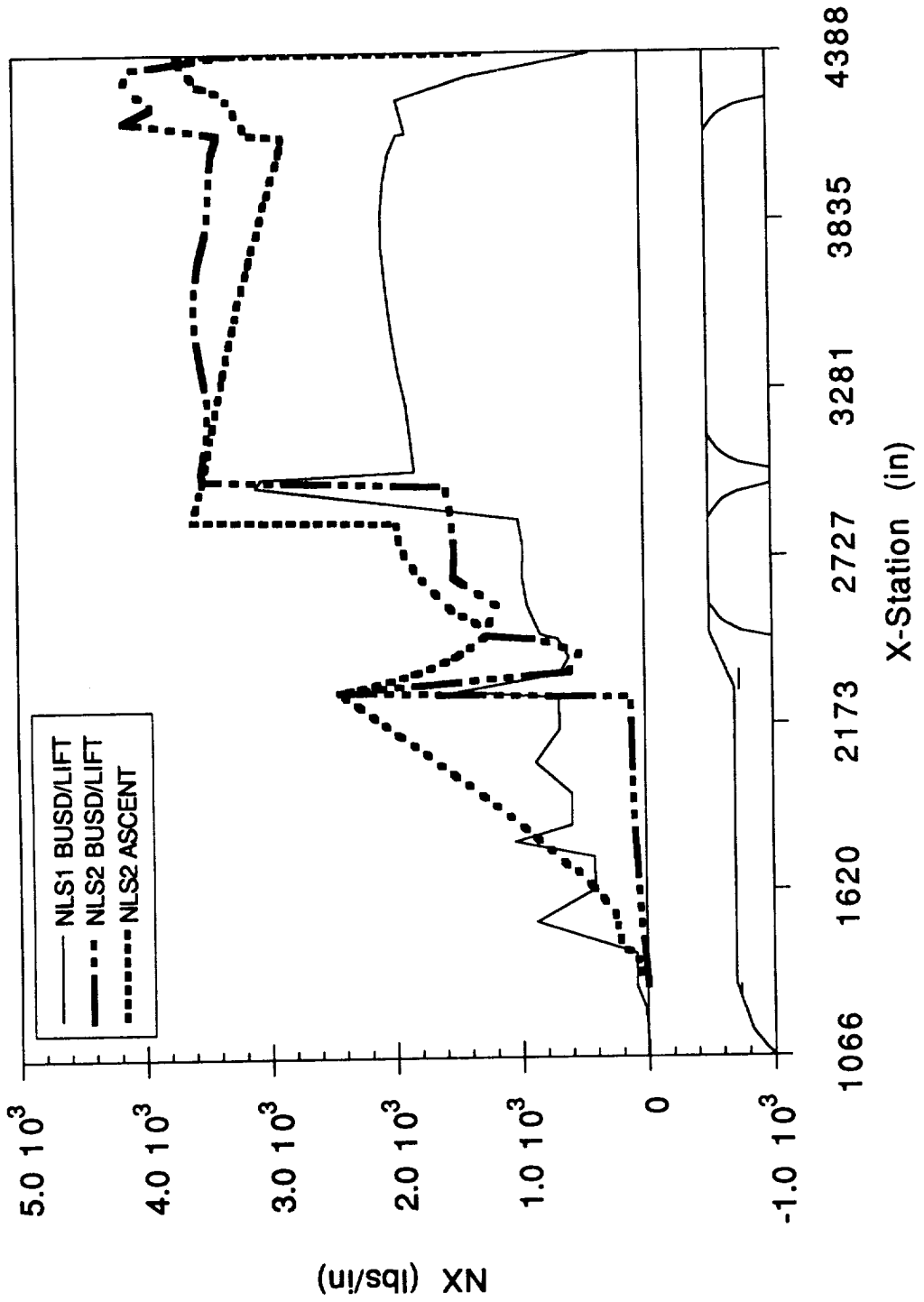

**NLS1 AND NLS2 W/O STME OUT
NX EVENT COMPARISON VS X-STATION**

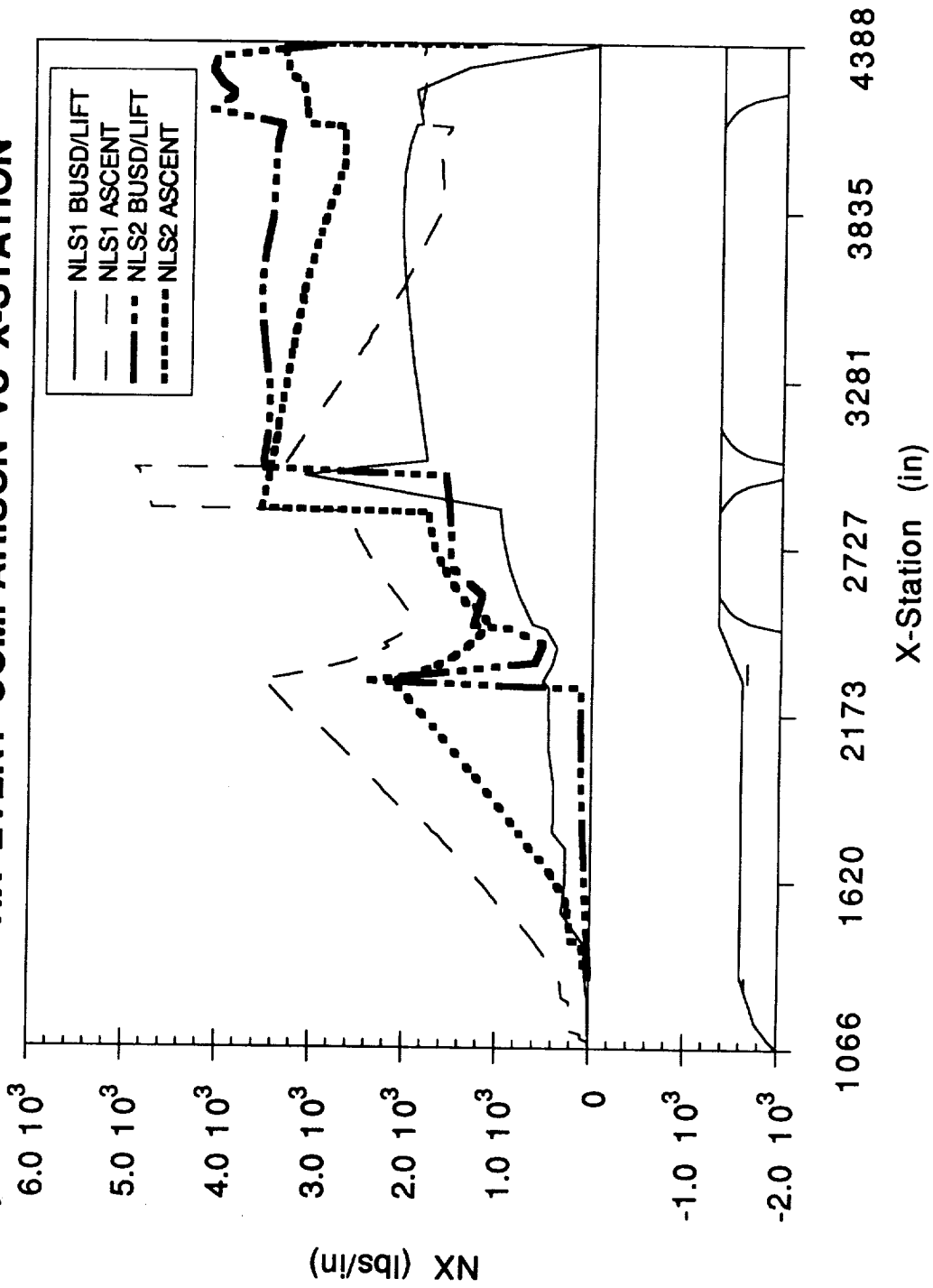

NLS1 INTERFACE LOADS SUMMARY

MEMBER	Maximum Load (Kips)	Minimum Load (Kips)	STS Hardware Upper Limit	STS Hardware Lower Limit	Flight Conditions
FTB1	59	-128	212	-190	Prelaunch/Prelaunch
FTB2	64	-129	214	-206	Prelaunch/Prelaunch
FTB3	211	-147	212	-95	Liftoff/Prelaunch
FTB4	142	-229	86	-219	Prelaunch/Liftoff
FTB5	419	-1332	178	-1672	Prelaunch/Prelaunch
FTB6	264	-1348	156	-1672	Ascent/Prelaunch
FTB7	85	-71	247	-233	Prelaunch/Prelaunch
FTB8	80	-71	263	-224	Prelaunch/Prelaunch
FTB9U	104	-113	295	-256	Prelaunch/Liftoff
FTB10U	111	-102	277	-293	Liftoff/Prelaunch
FTBA	121	-122	127	-267	Prelaunch/Liftoff
FTBB	115	-126	277	-121	Liftoff/Prelaunch
P (08)	66	-21	271	-264	Ascent/Ascent
P (09)	67	-24	358	-291	Ascent/Ascent
P (10)	41	-38	233	-274	Ascent/Ascent
P (11)	66	-21	265	-299	Ascent/Ascent
P (12)	67	-24	296	-274	Ascent/Ascent
P (13)	41	-38	244	-258	Ascent/Ascent
MTBLS	9235	-9000	11800	-11800	Ascent/Ascent
MTBRS	8994	-9238	11800	-11800	Ascent/Ascent

1

2

3

**NLS 1 and NLS 2
Cycle 1 and Cycle 0 Loads Comparisons**

NLS1 CORE PRELAUNCH CYCLE1 AND CYCLE0 NX COMPARISON VS X-STATION

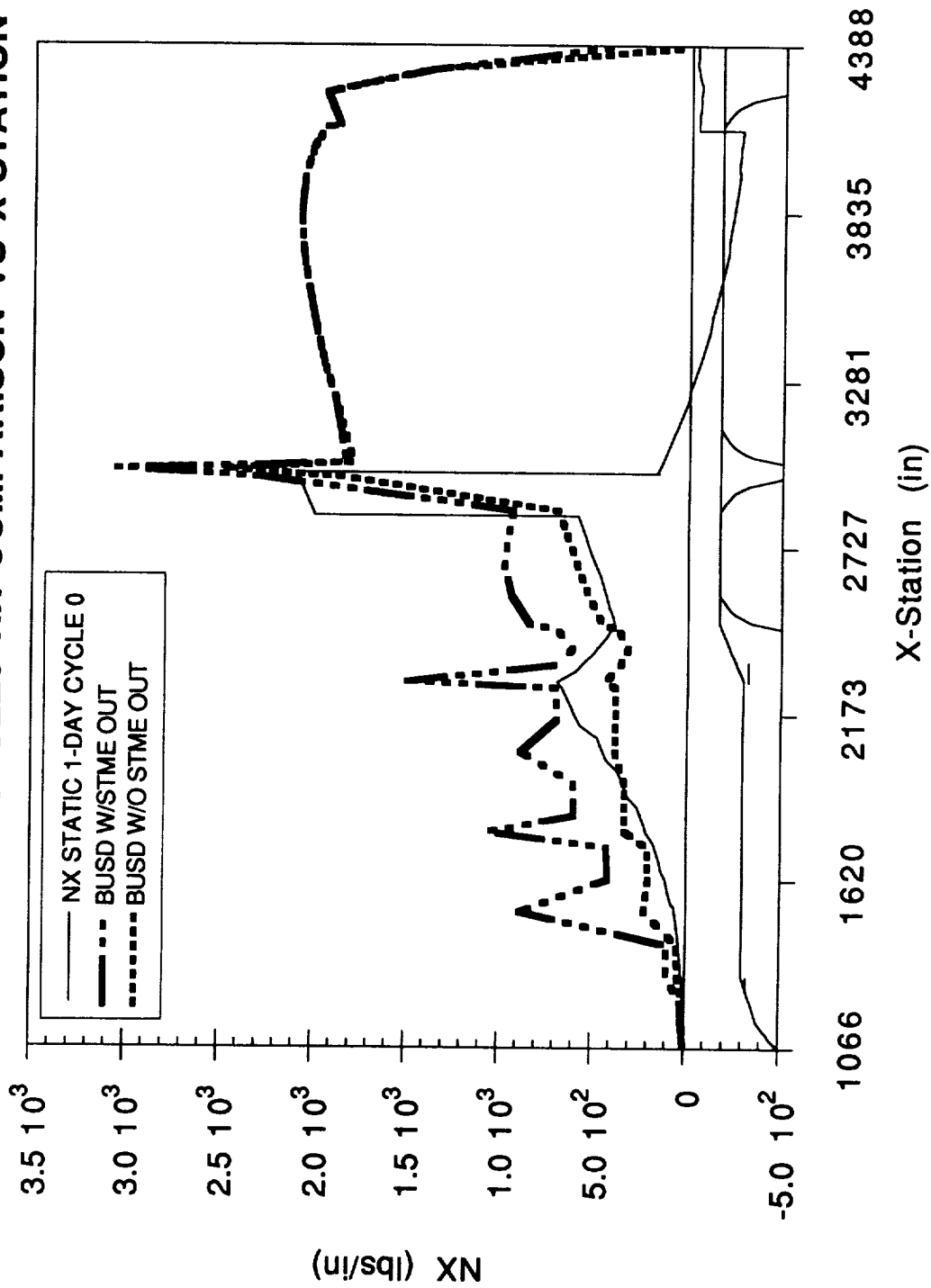

((

**NLS2 PRELAUNCH
CYCLE1 AND CYCLE0 NX COMPARISON VS X-STATION**

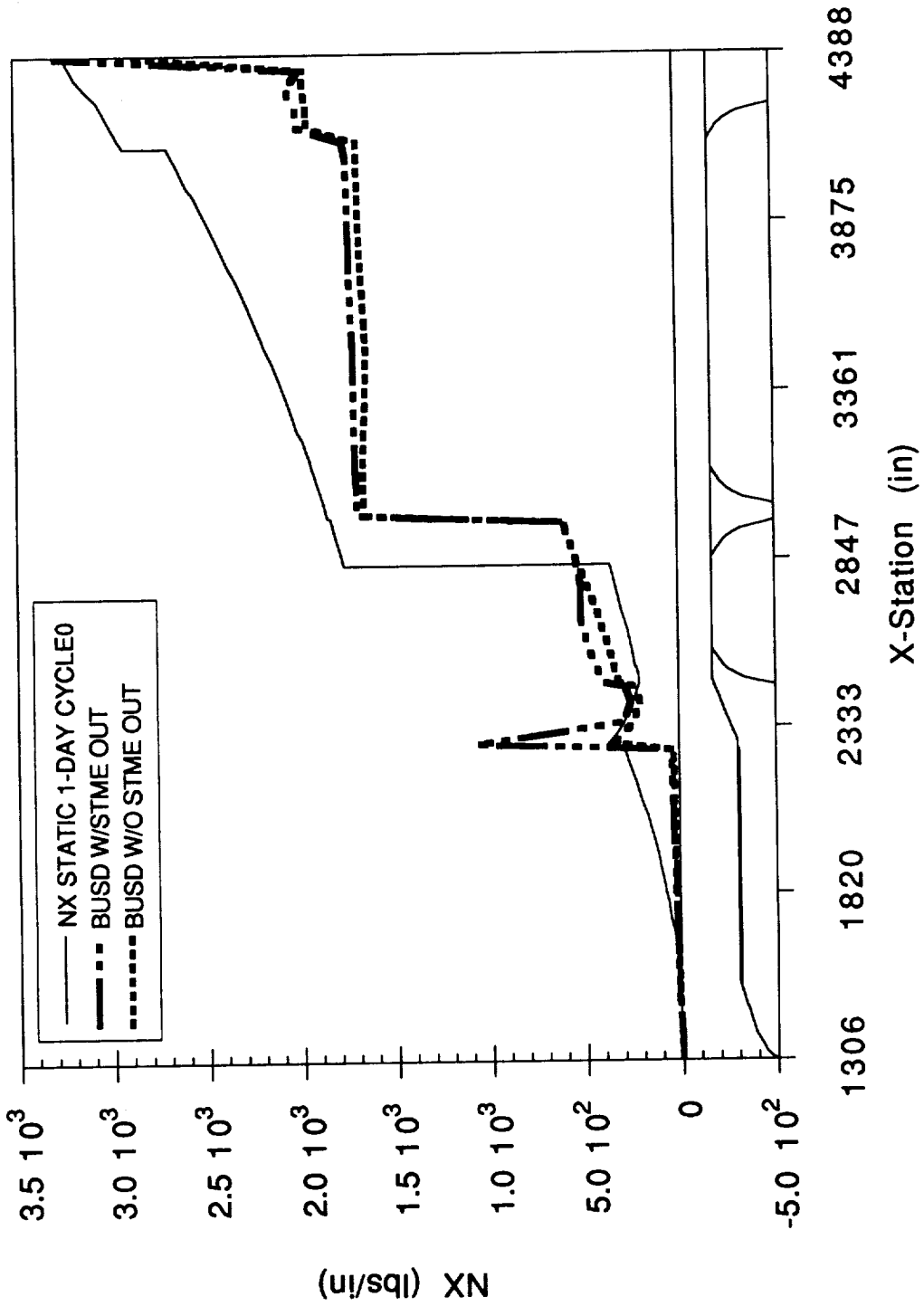

**NLS1 CORE MAX-Q
CYCLE1 AND CYCLE0 NX COMPARISON VS X-STATION**

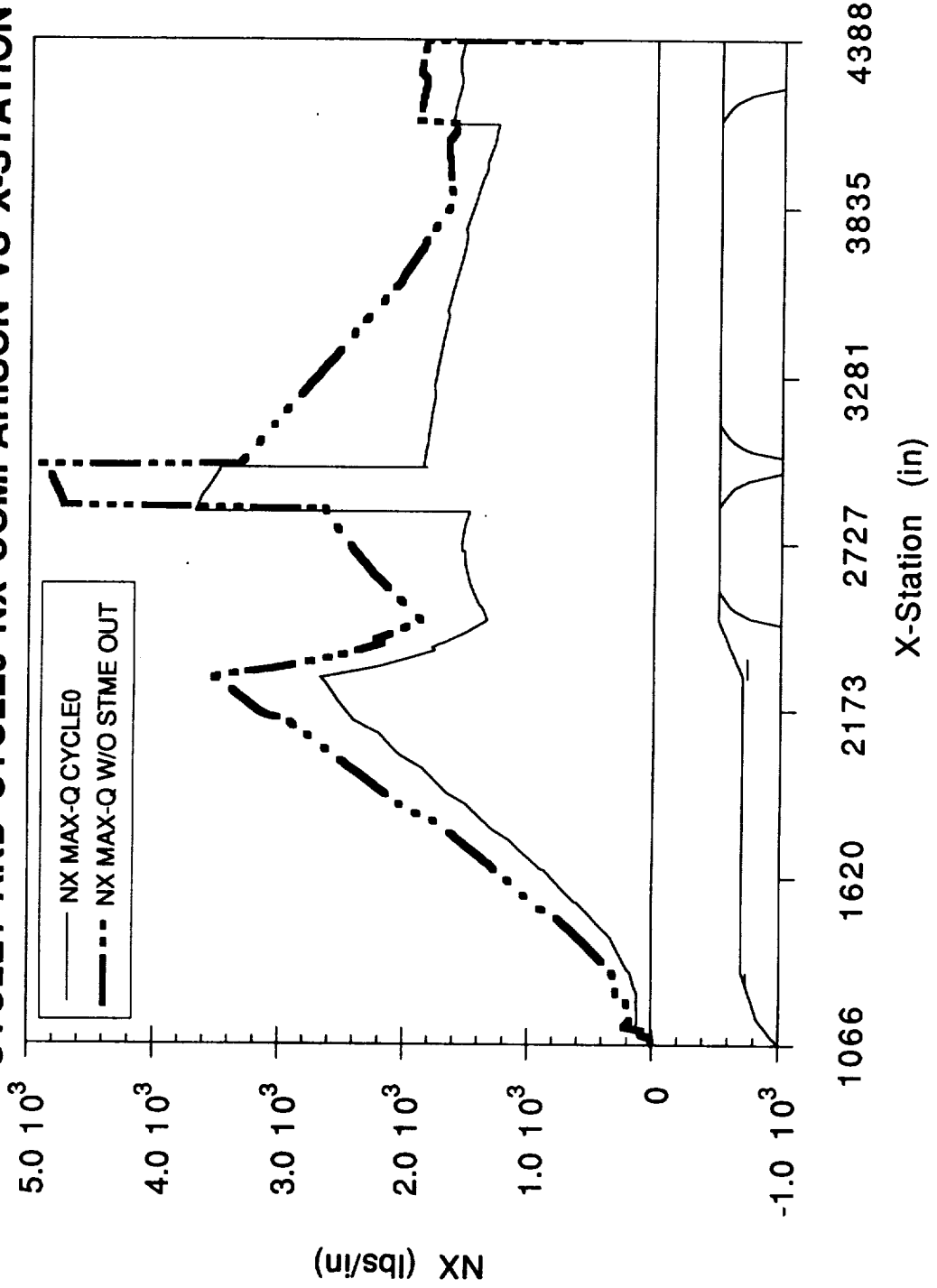

NLS2 MAX-Q
CYCLE1 AND CYCLE0 NX COMPARISON VS X-STATION

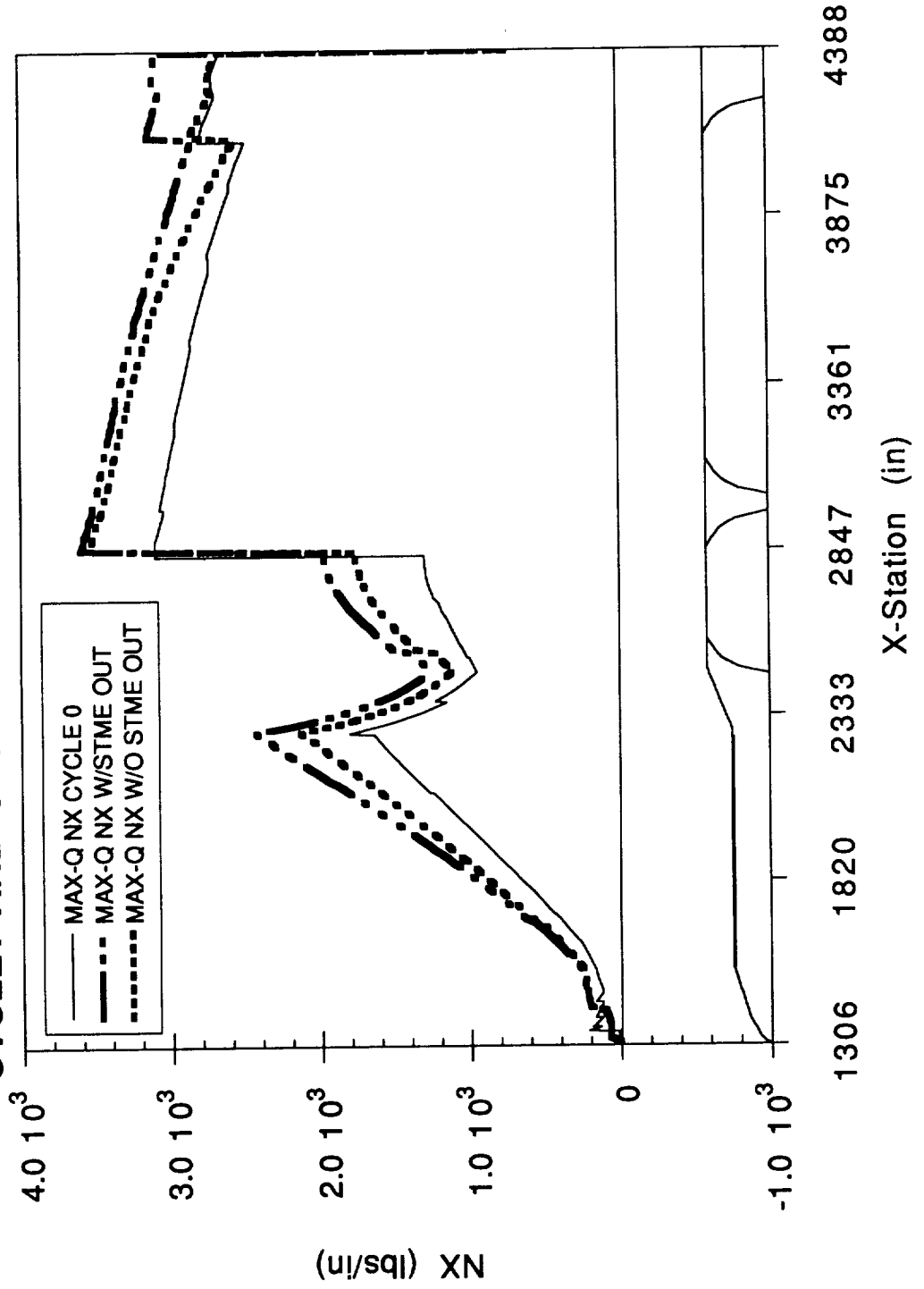

**NLS1 CORE PRELAUNCH
CYCLE1 AND CYCLE0 STATIC NX COMPARISON**

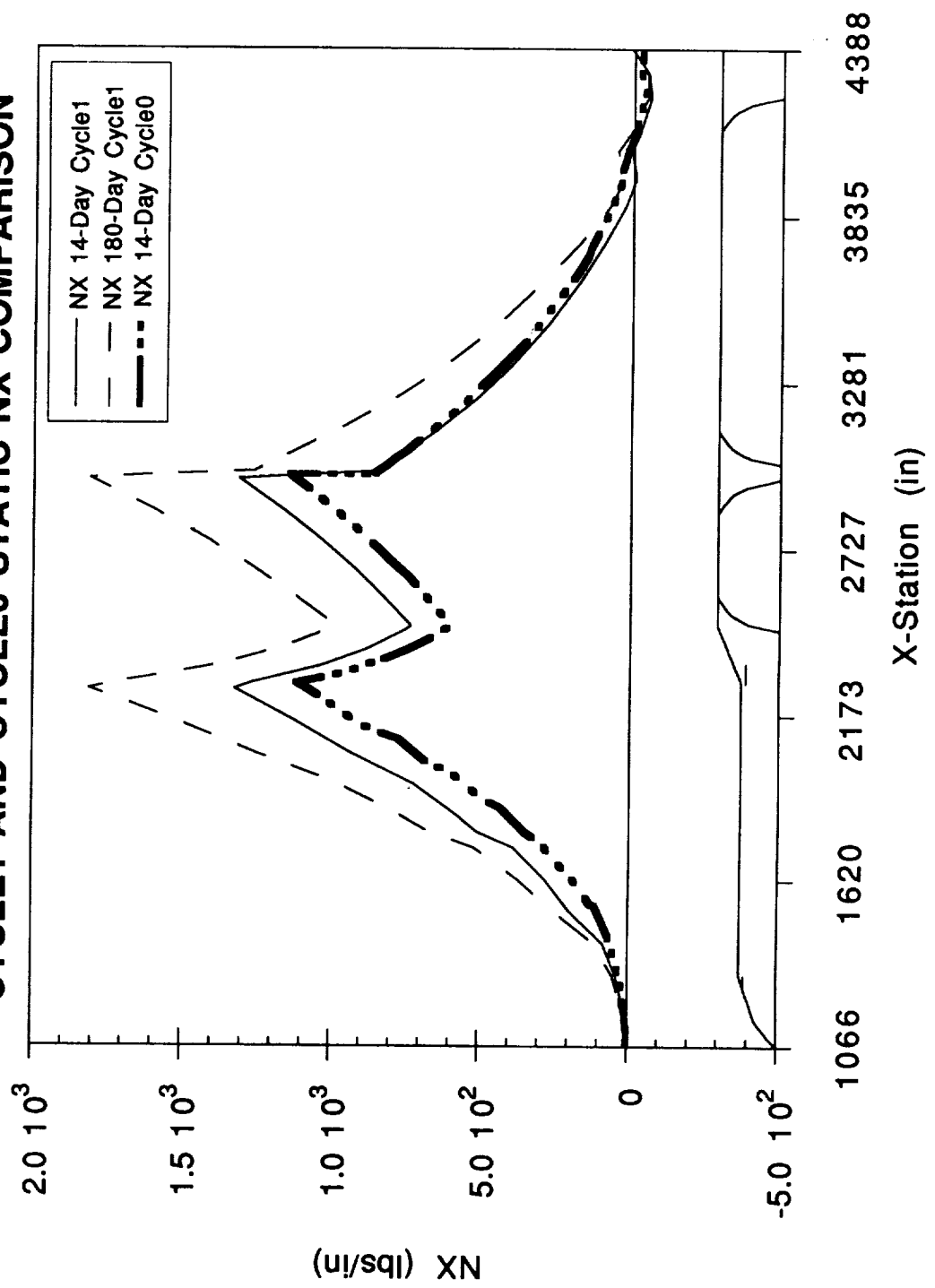

NLS2 PRELAUNCH CYCLE1 AND CYCLE0 STATIC NX COMPARISON

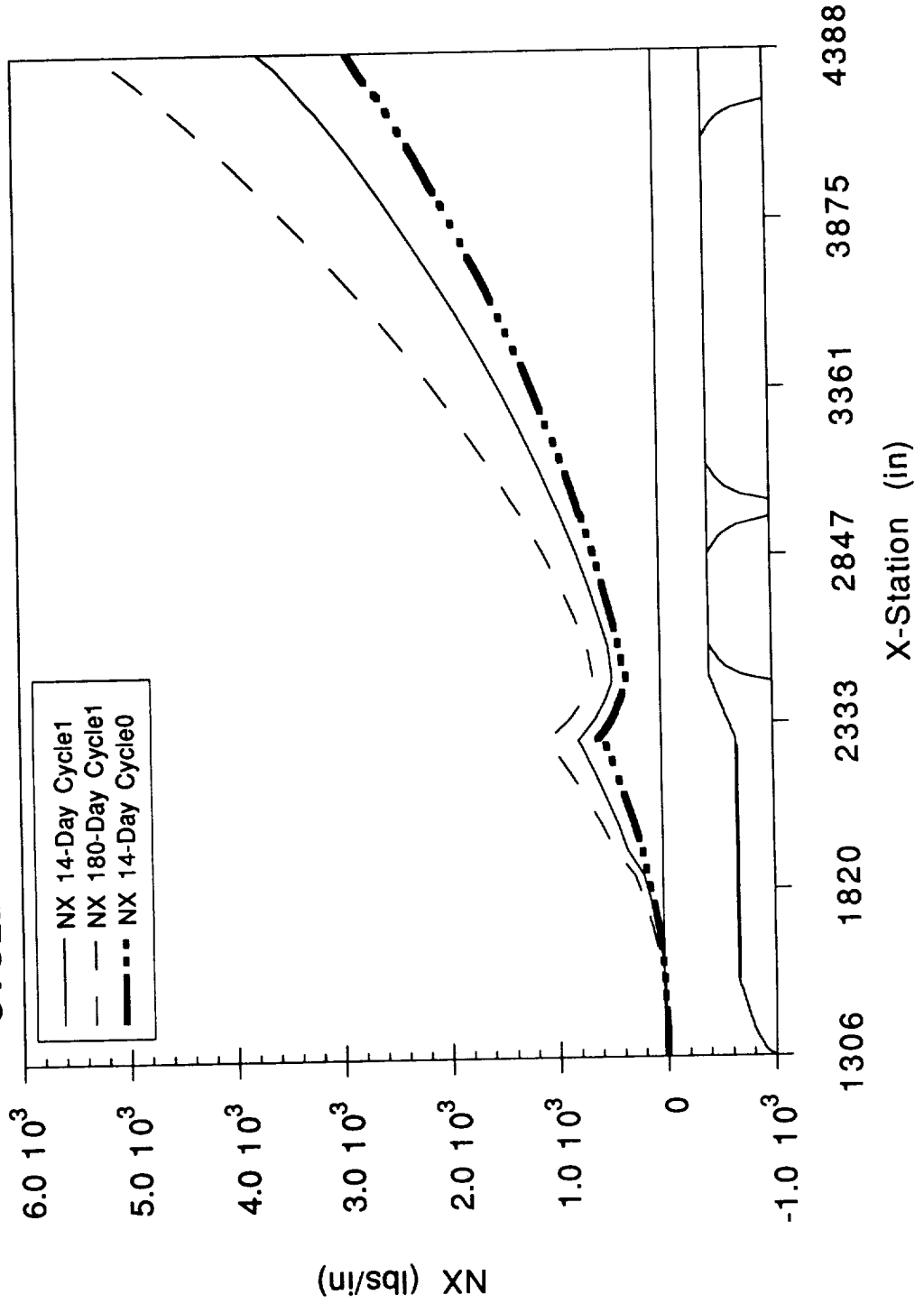

**NLS1 NOMINAL
3 km WINDS with NO LOAD RELIEF**

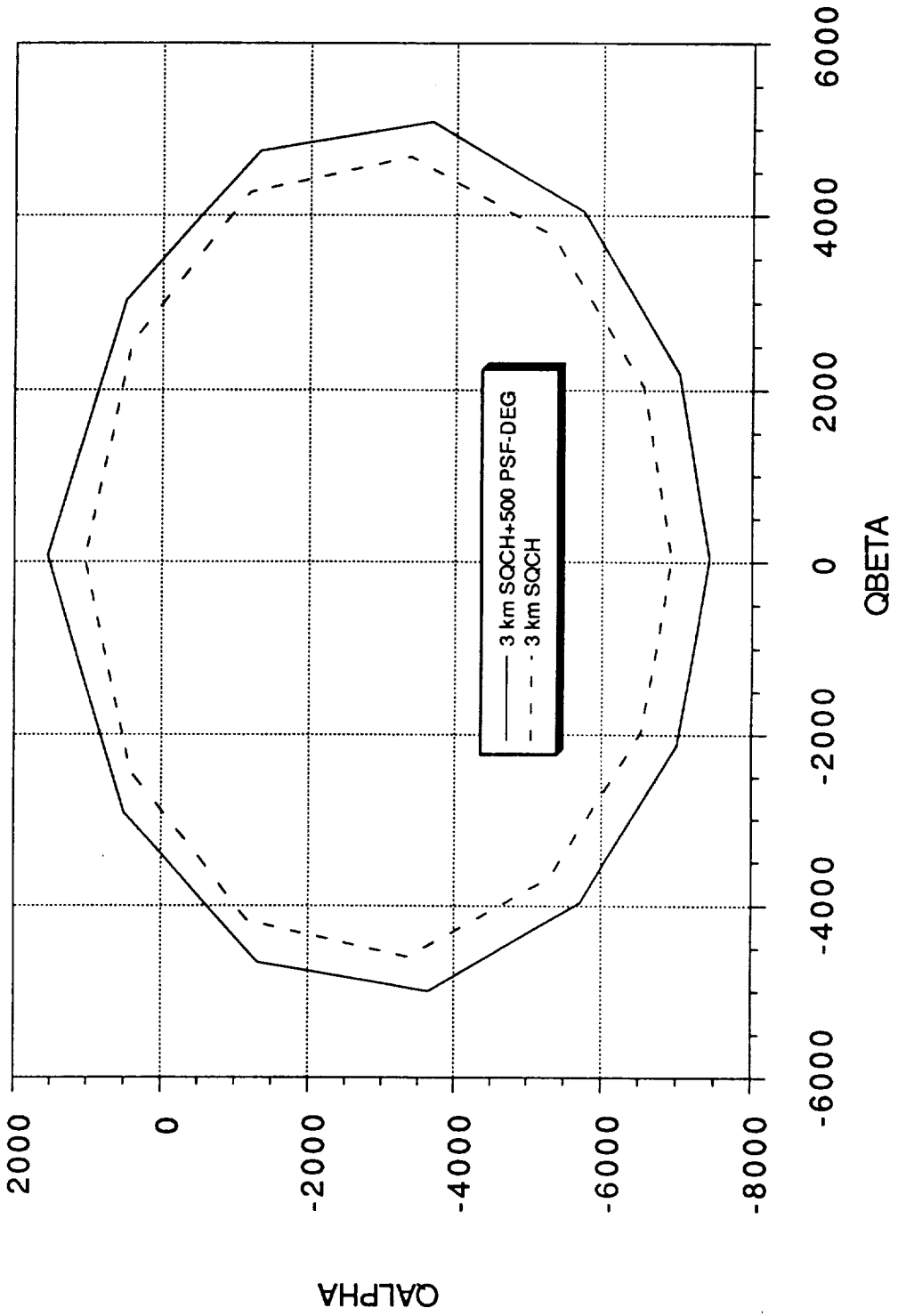

NLS1 NOMINAL
4 km Winds with No Load Relief

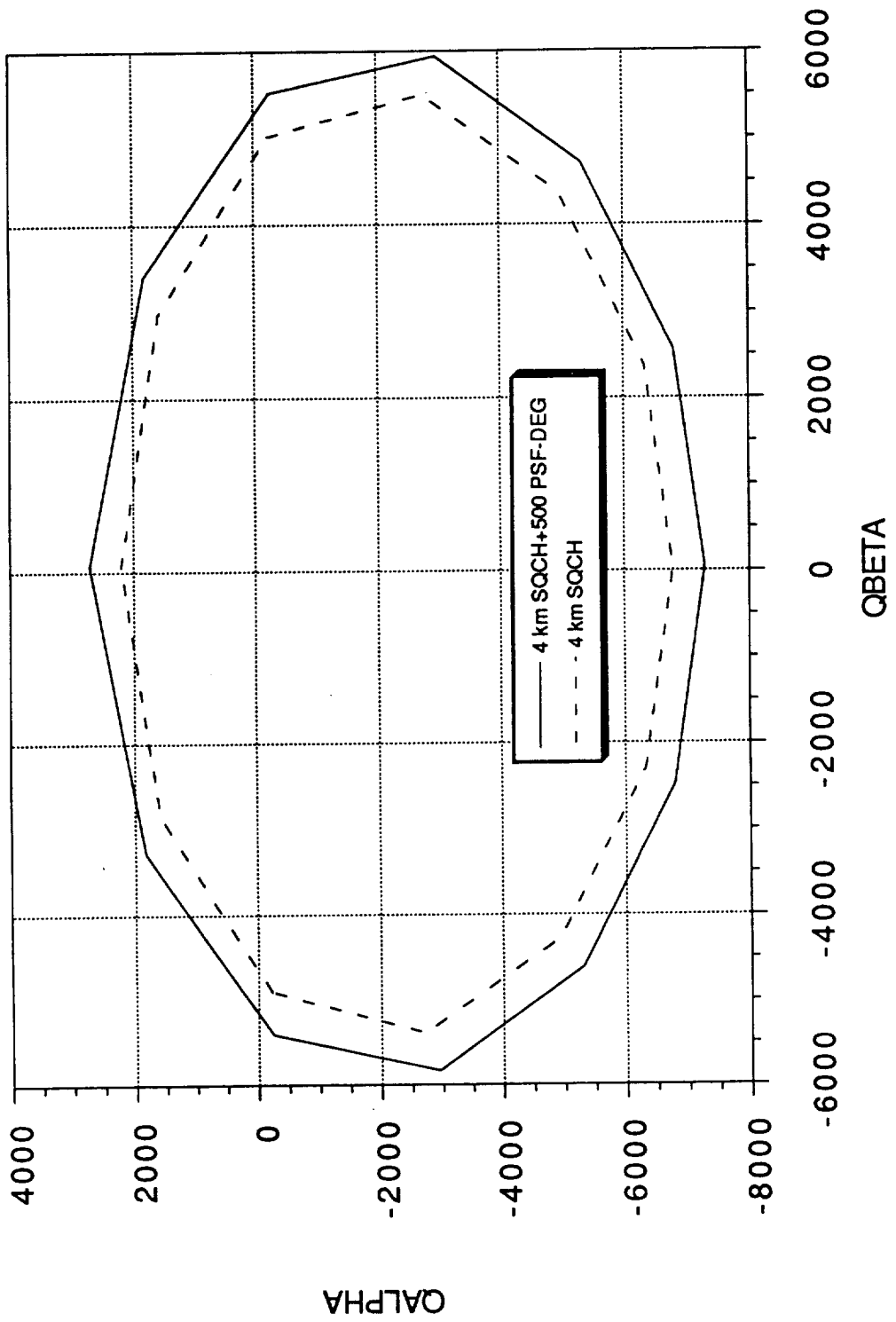

**NLS1 Nominal
5 km Winds with No Load Relief**

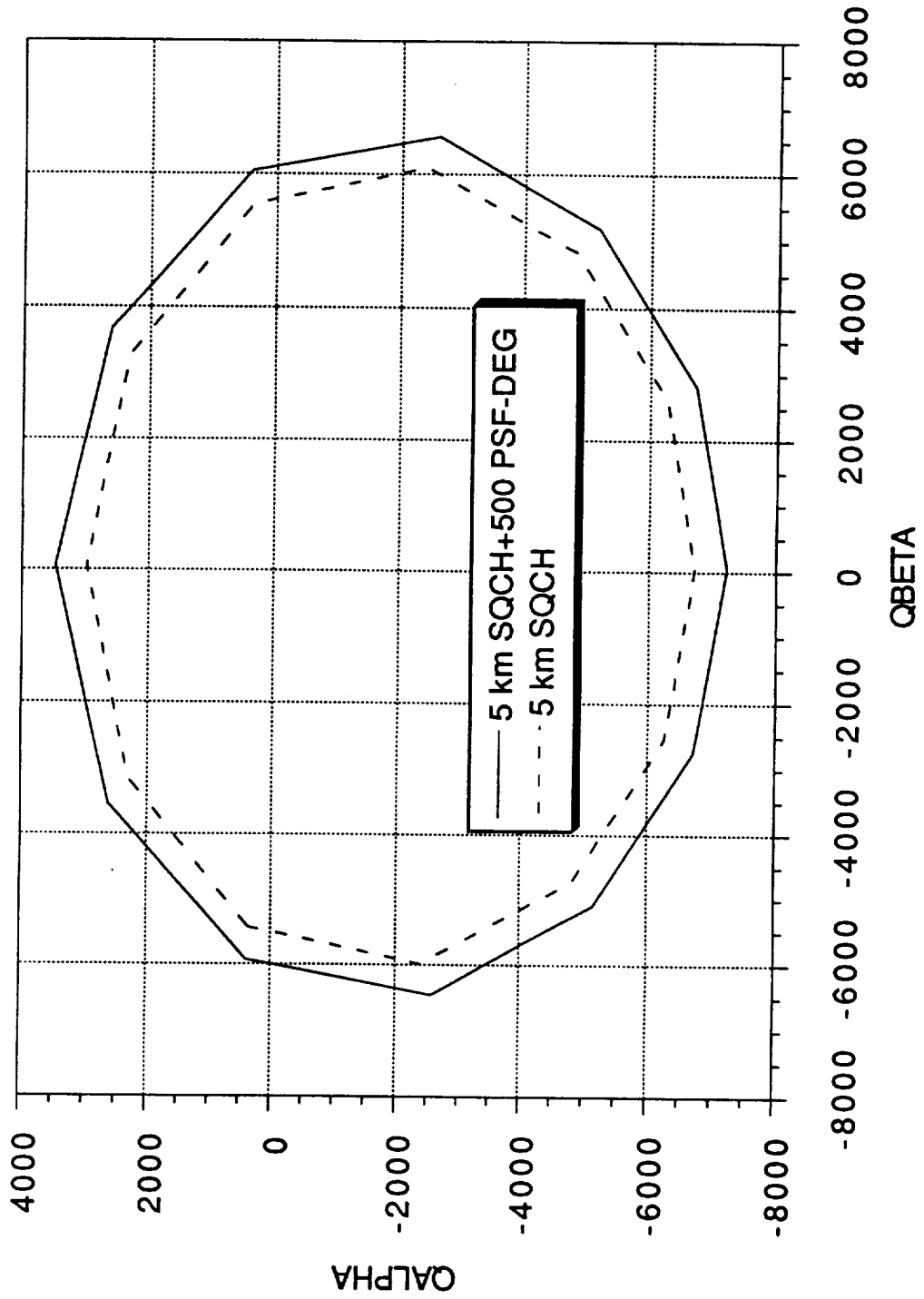

NLS1 Nominal 6 km Winds With No Load Relief

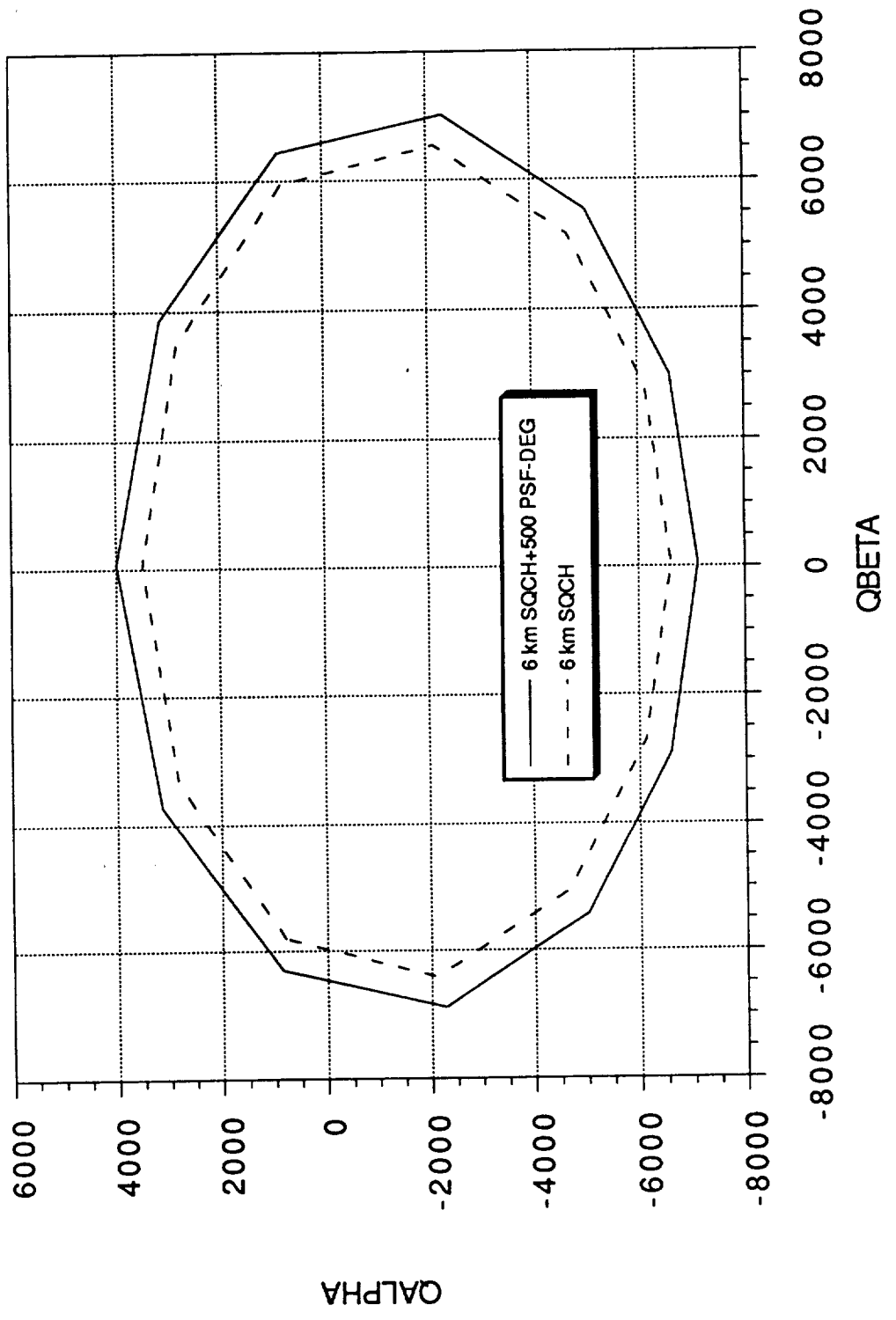

NLS1 Nominal 8 km Winds with No Load Relief

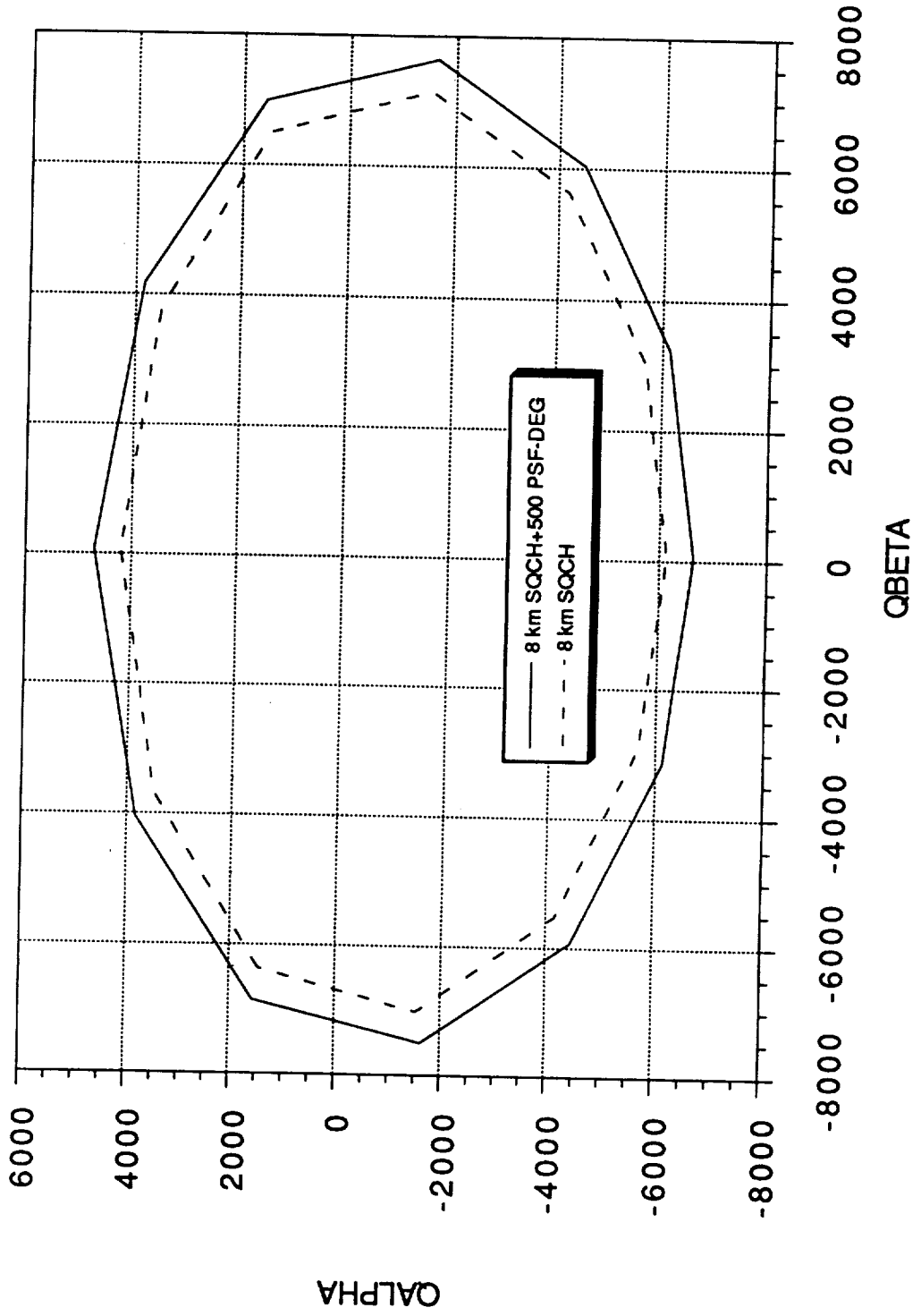

(((

NLS1 Nominal 10 km Winds with No Load Relief

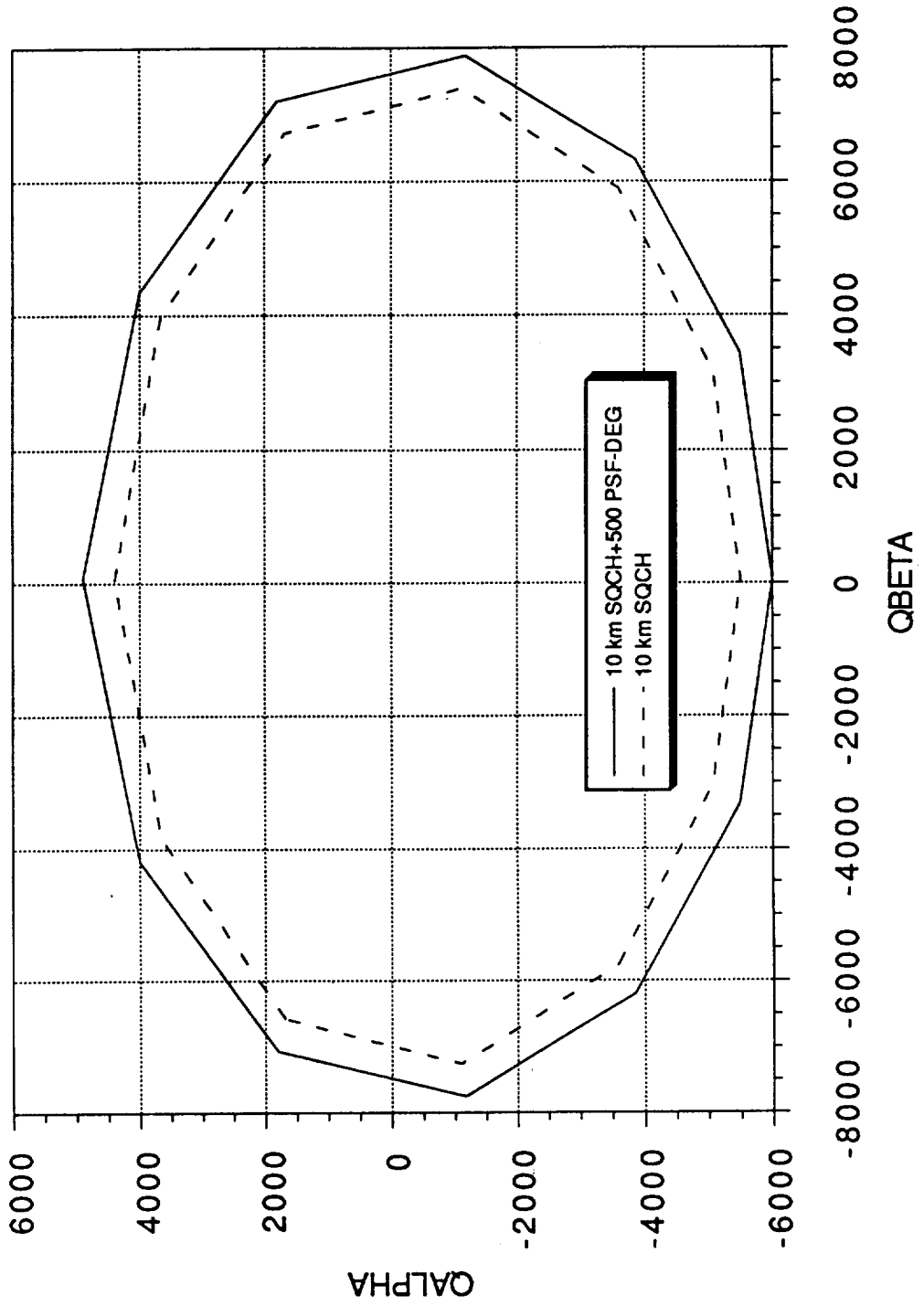

NLS1 Nominal 11 km Winds with No Load Relief

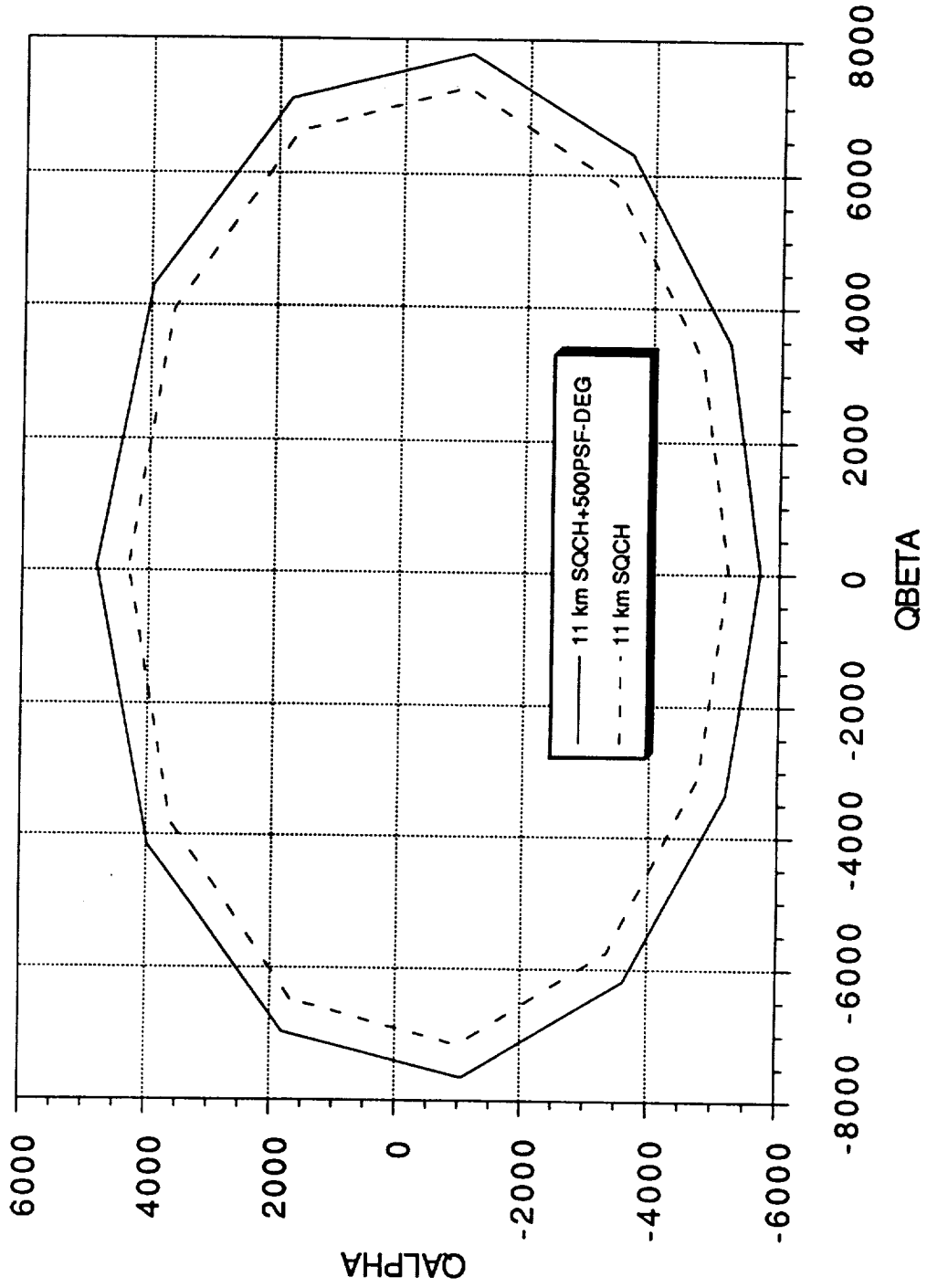

(((

NLS1 Nominal 12 km Winds with No Load Relief

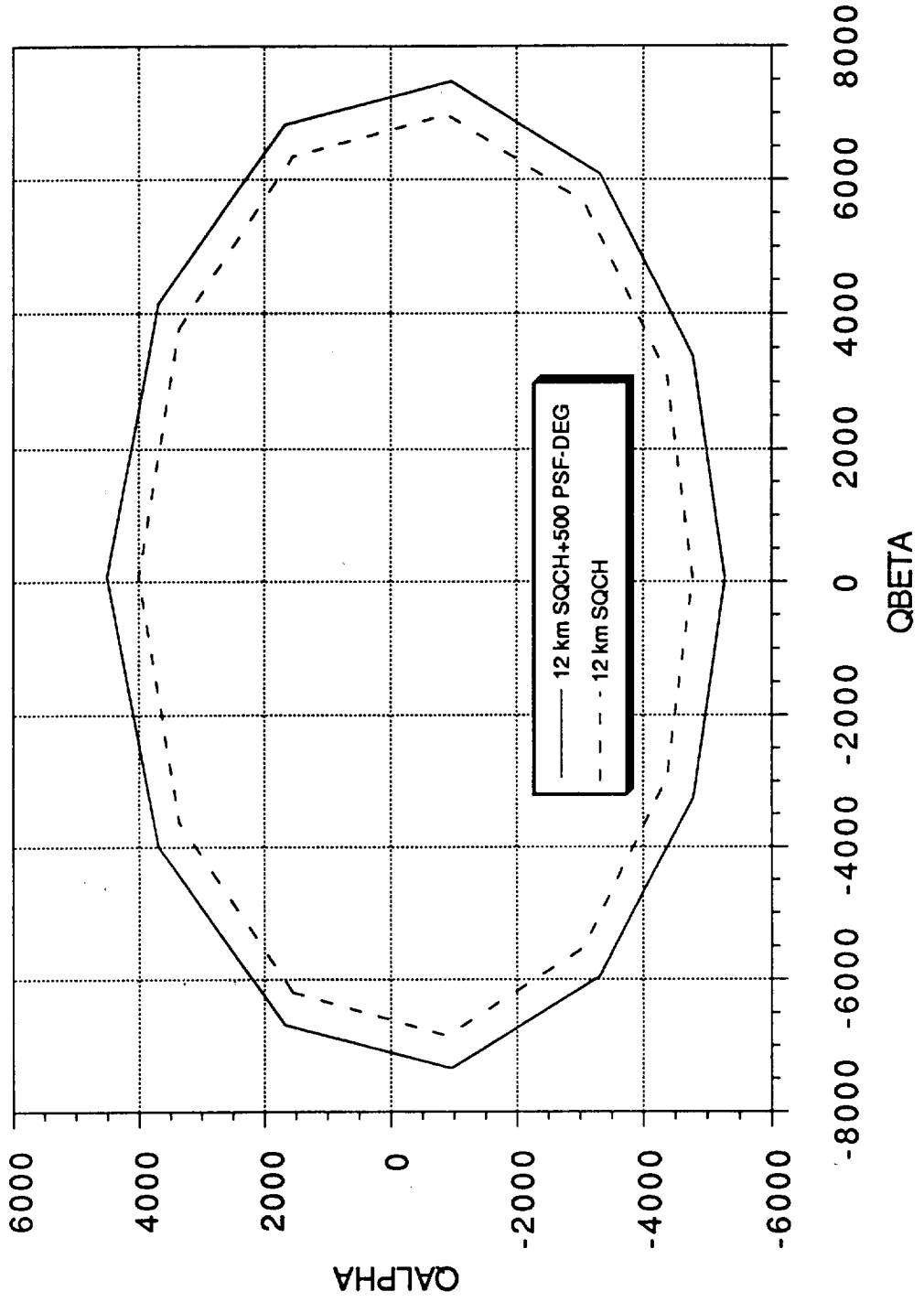

**NLS1 Nominal
13 km Winds with NO Load Relief**

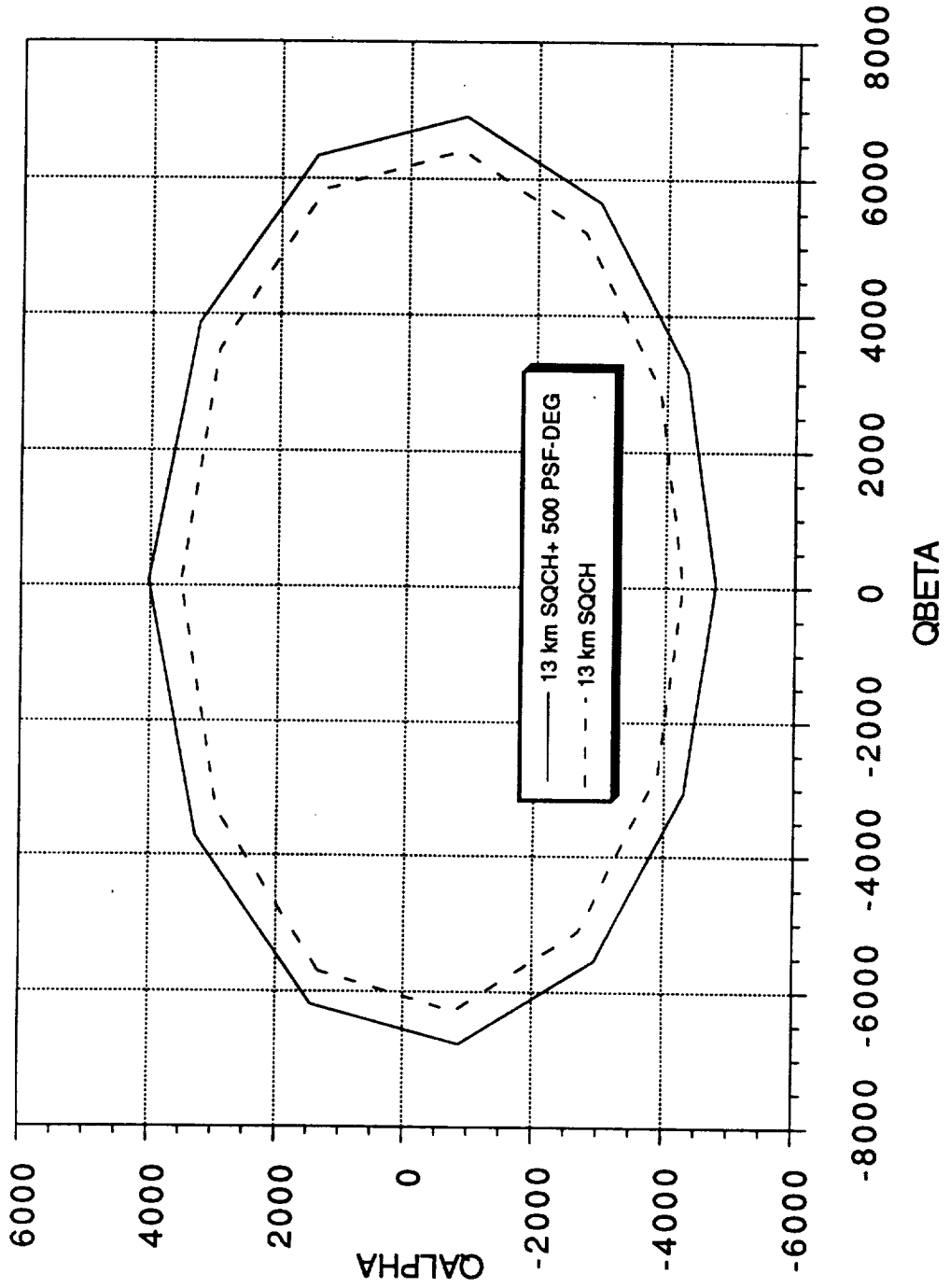

NLS1 Nominal 15 km Winds with No Load Relief

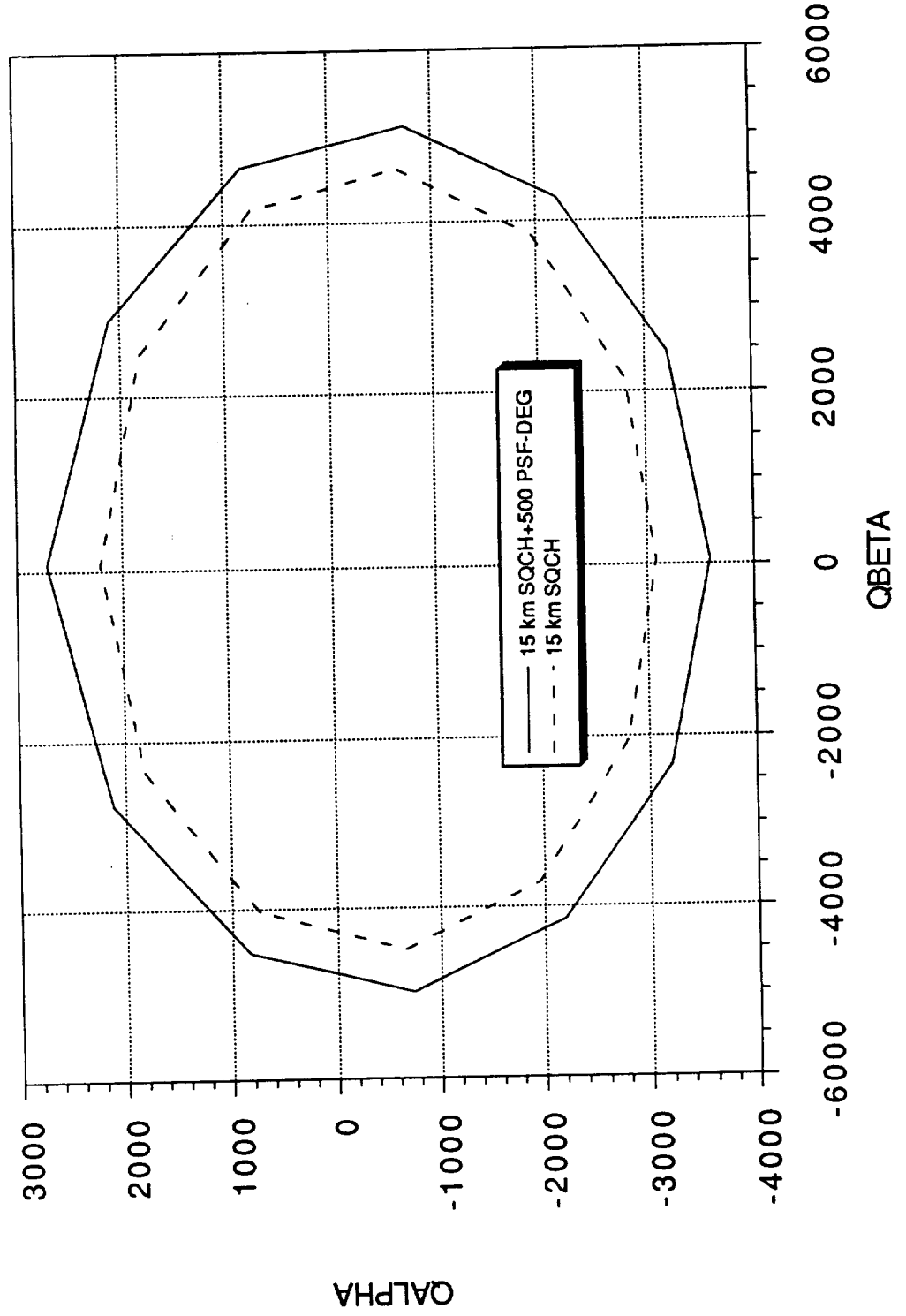

**NLS2 Nominal
3 Km Winds with No Load Relief**

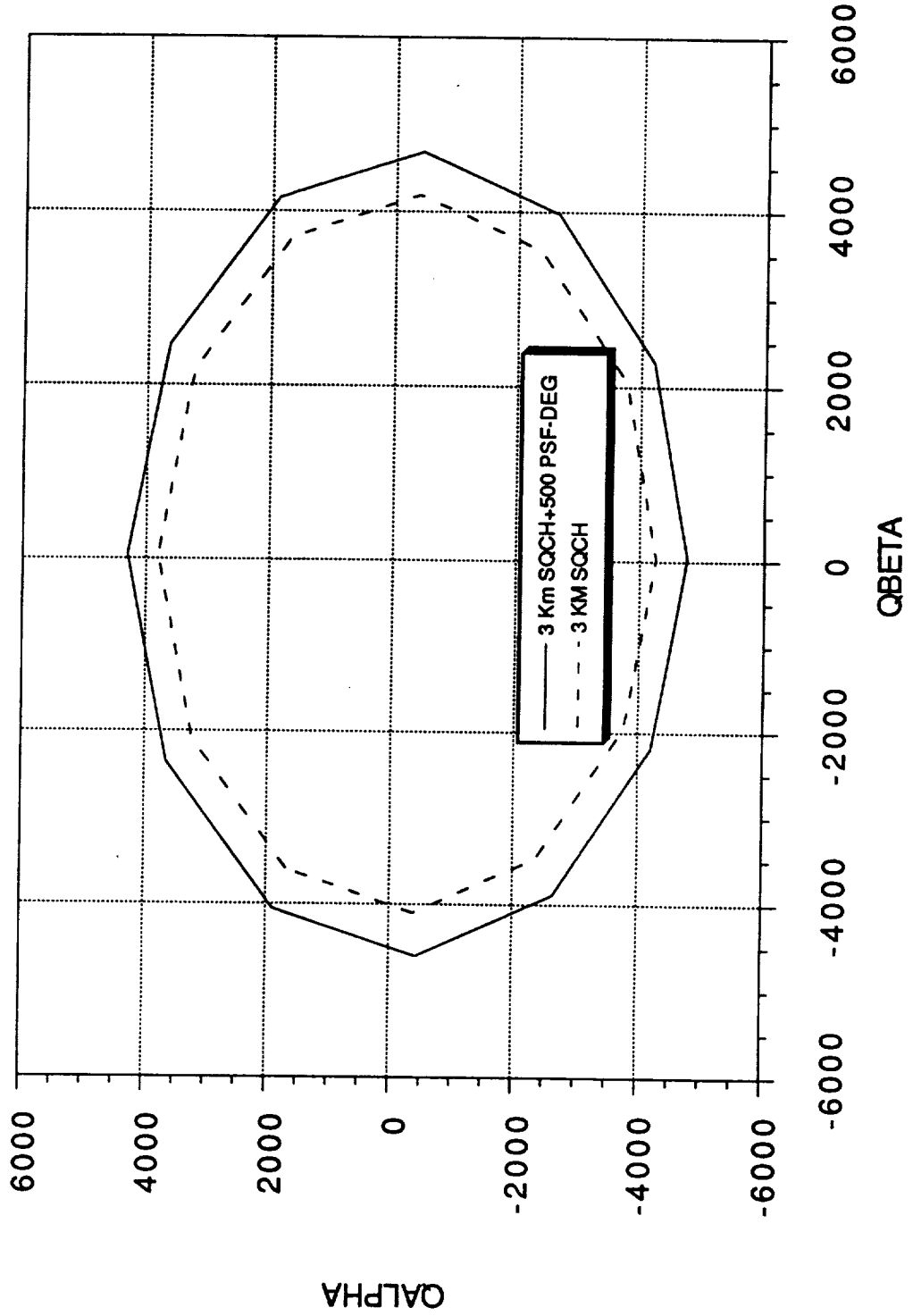

**NLS2 Nominal
6 Km Winds with No Load Relief**

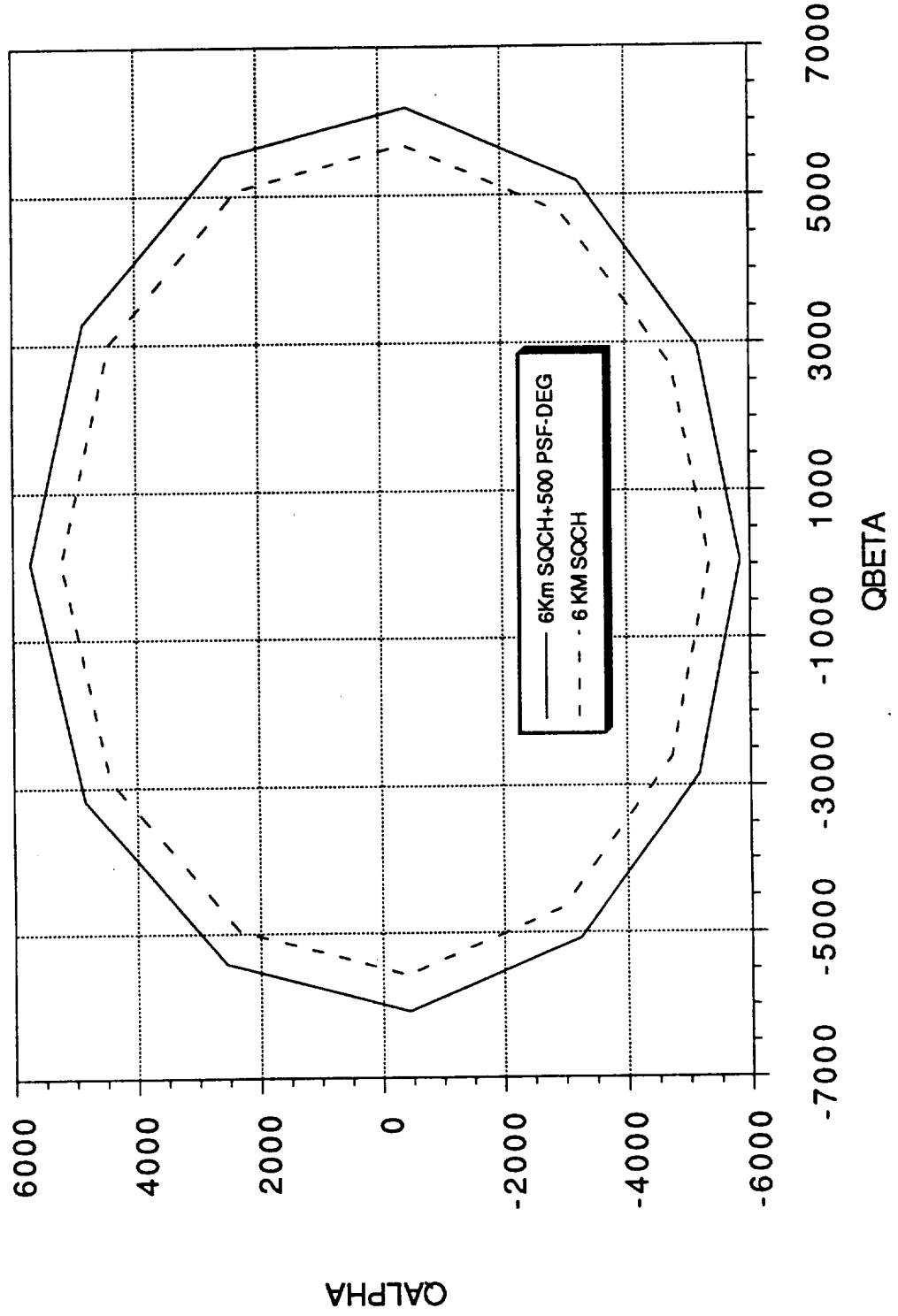

**NLS2 Nominal
8 Km Winds with No Load Relief**

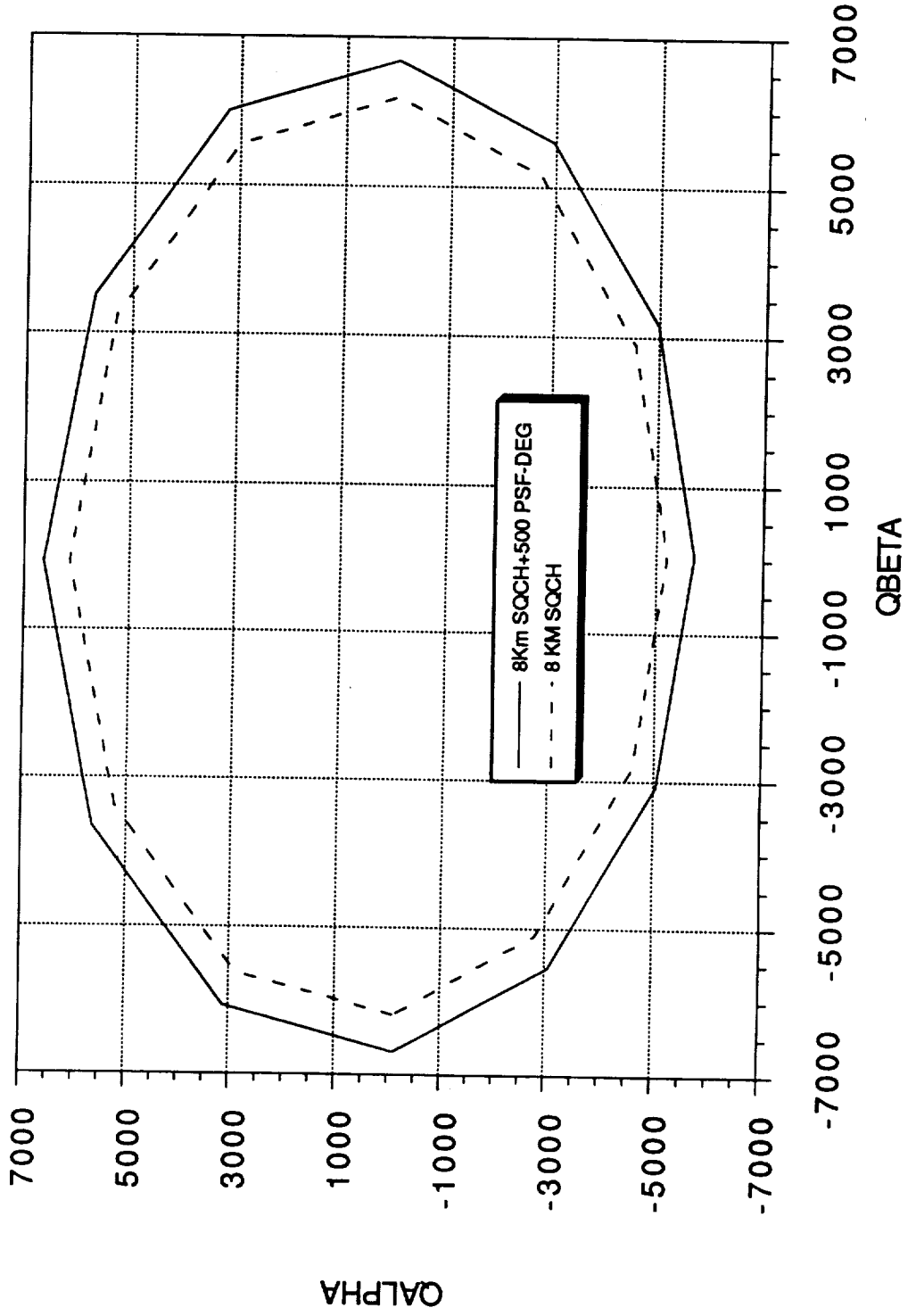

NLS2 Nominal 9 Km Winds with No Load Relief

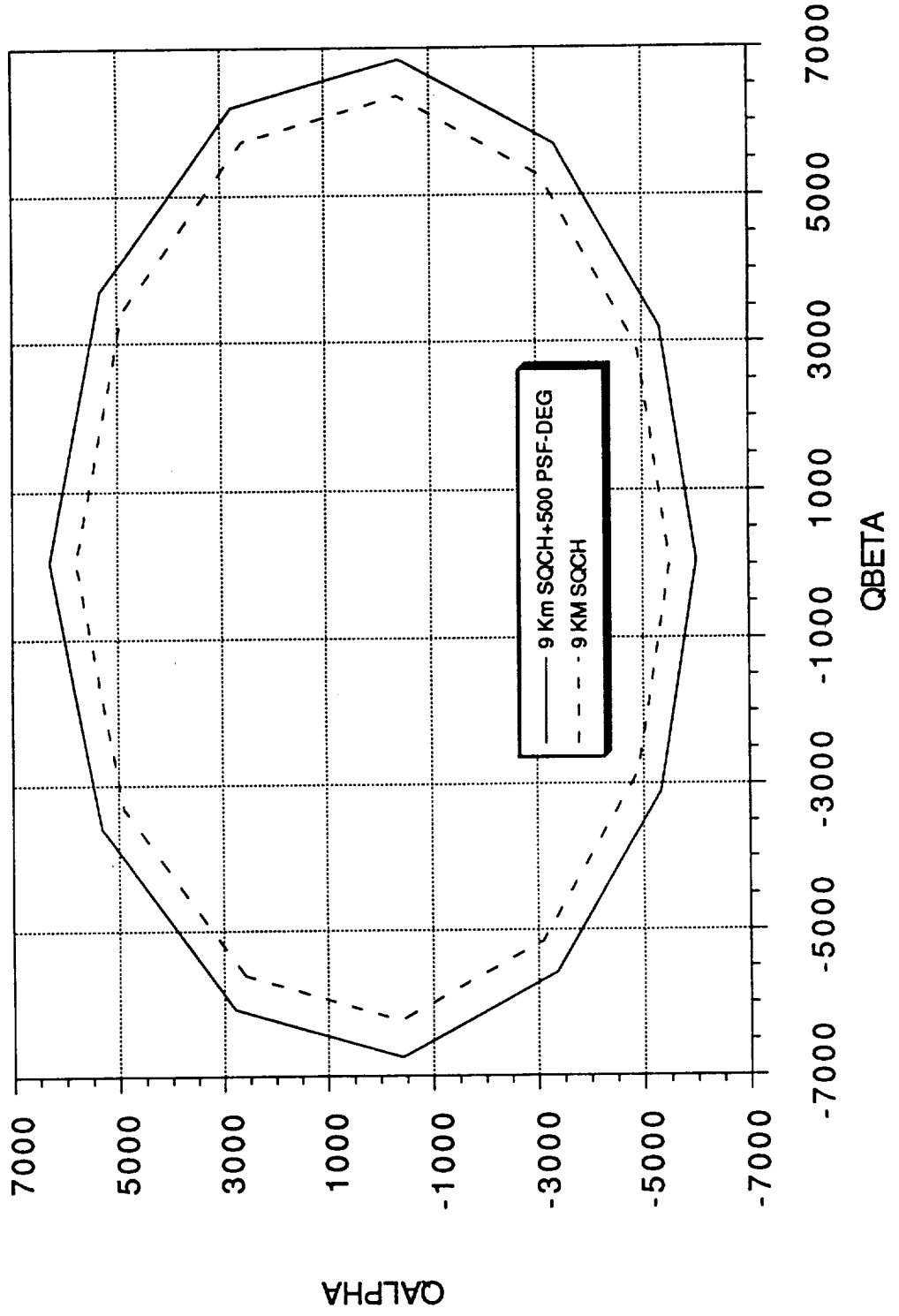

NLS2 Stage Nominal 10 Km Winds with No Load Relief

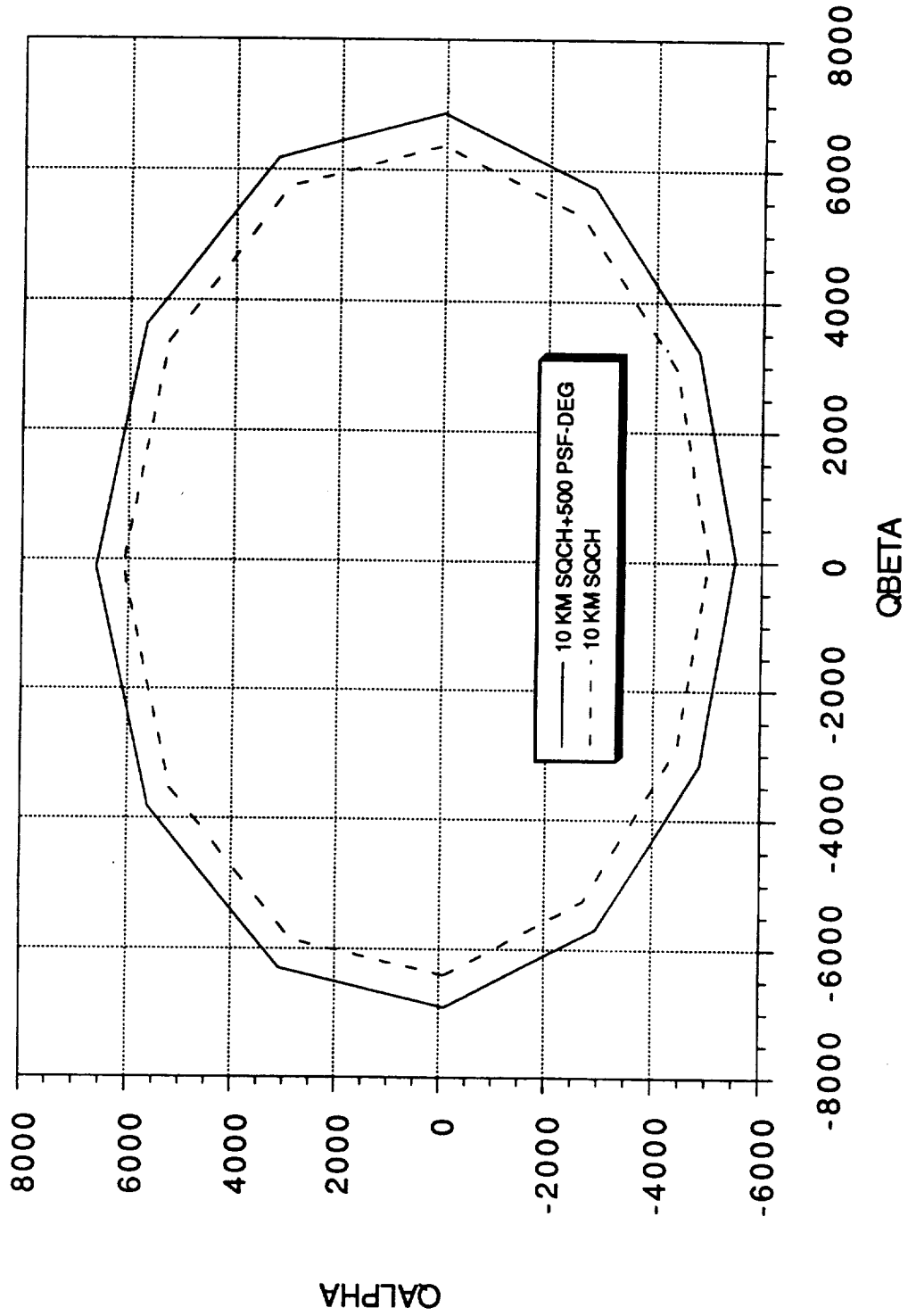

(((

**NLS2 Stage Nominal
11 Km Winds with No Load Relief**

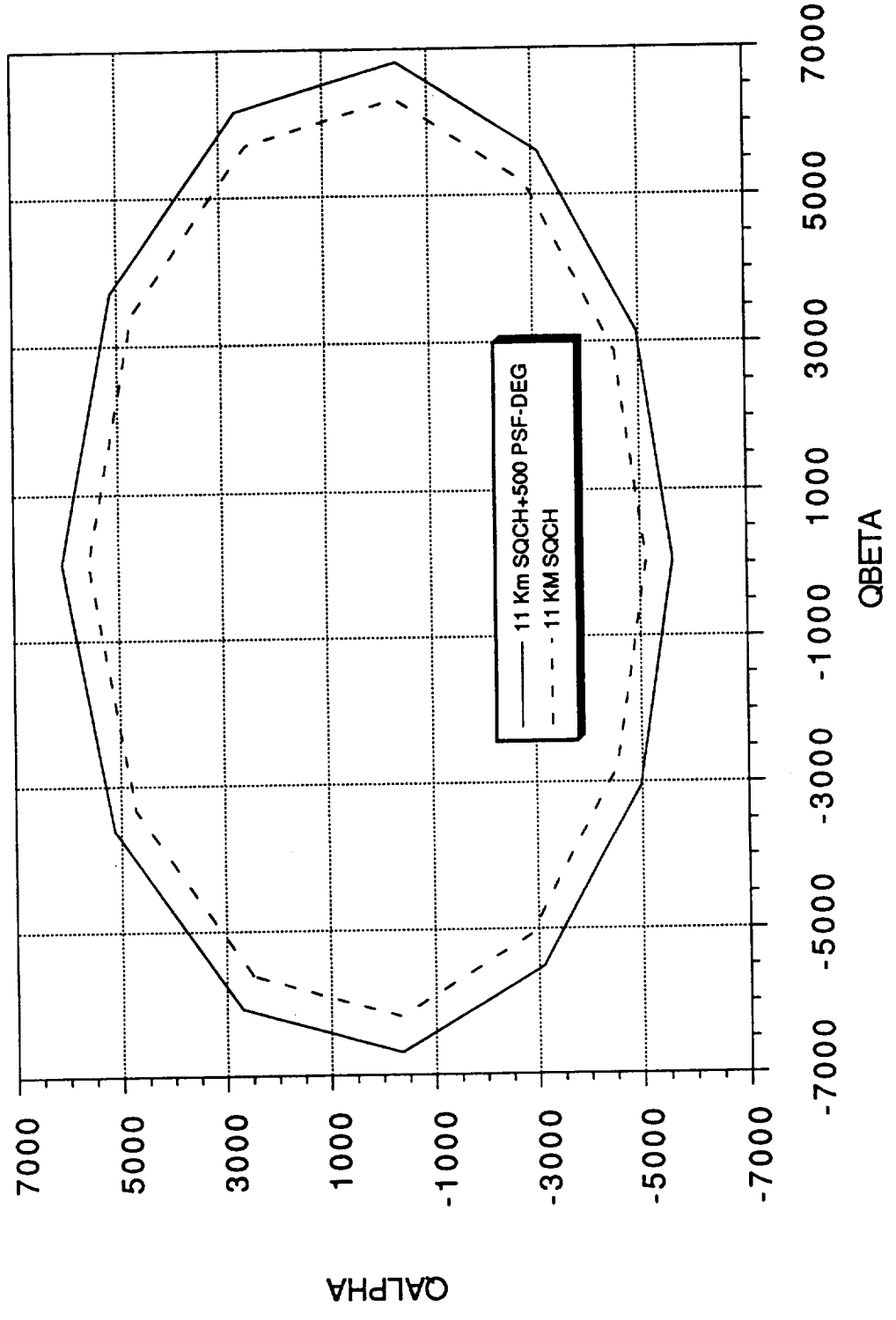

C-4

NLS2 Nominal 12 Km Winds with No Load Relief

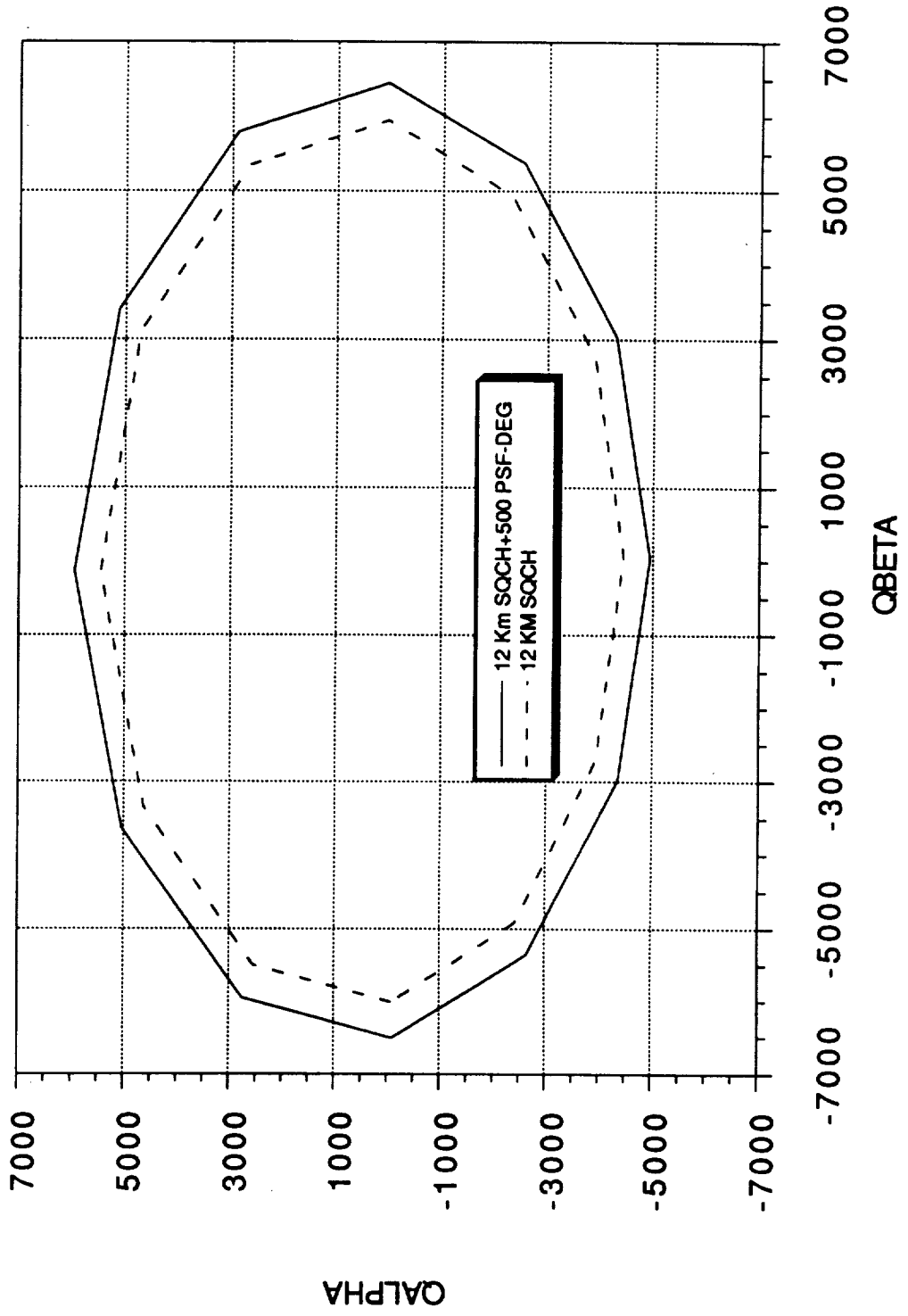

(((

**NLS2 Nominal
13 Km Winds with No Load Relief**

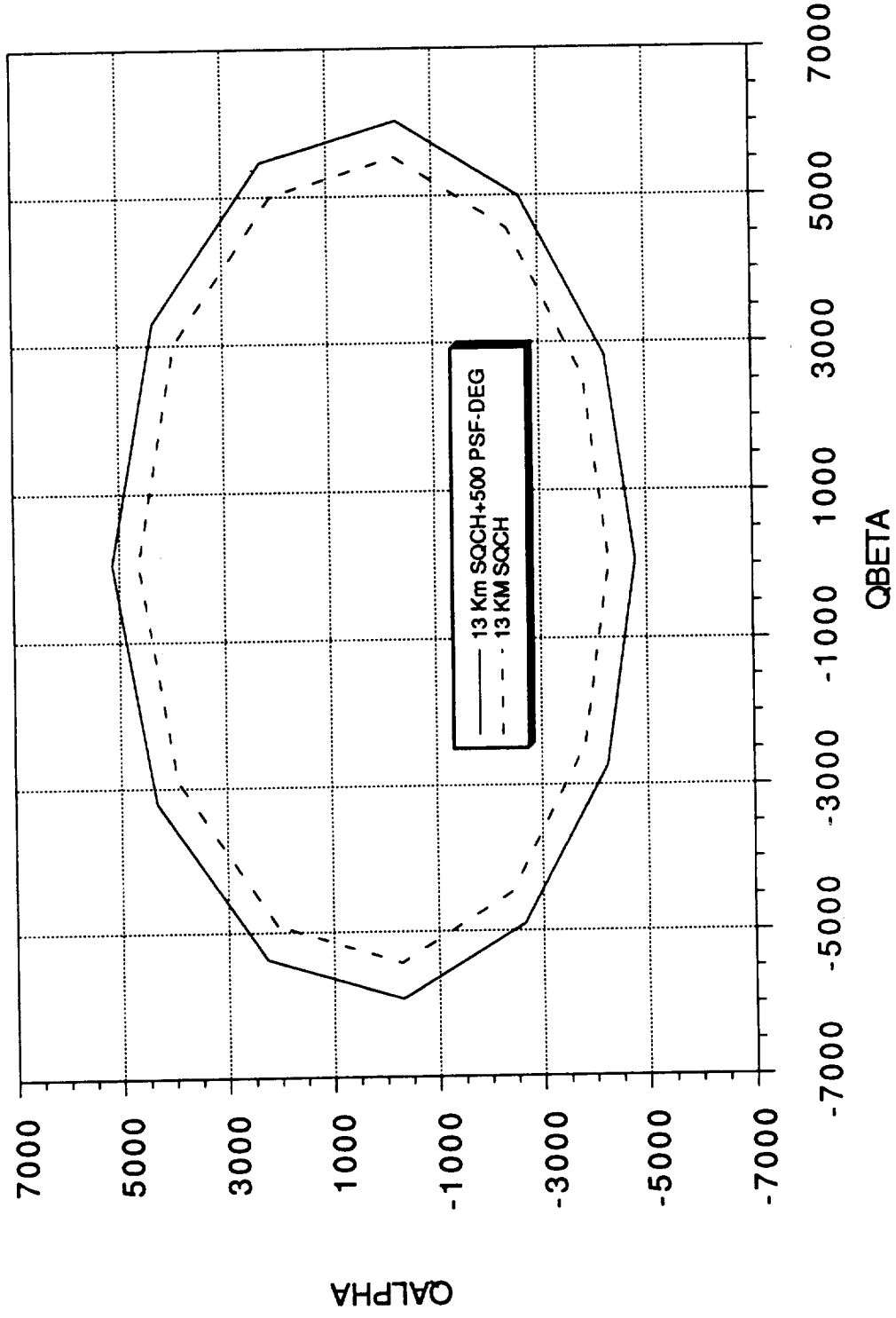

**NLS2 Nominal
14 Km Winds with No Load Relief**

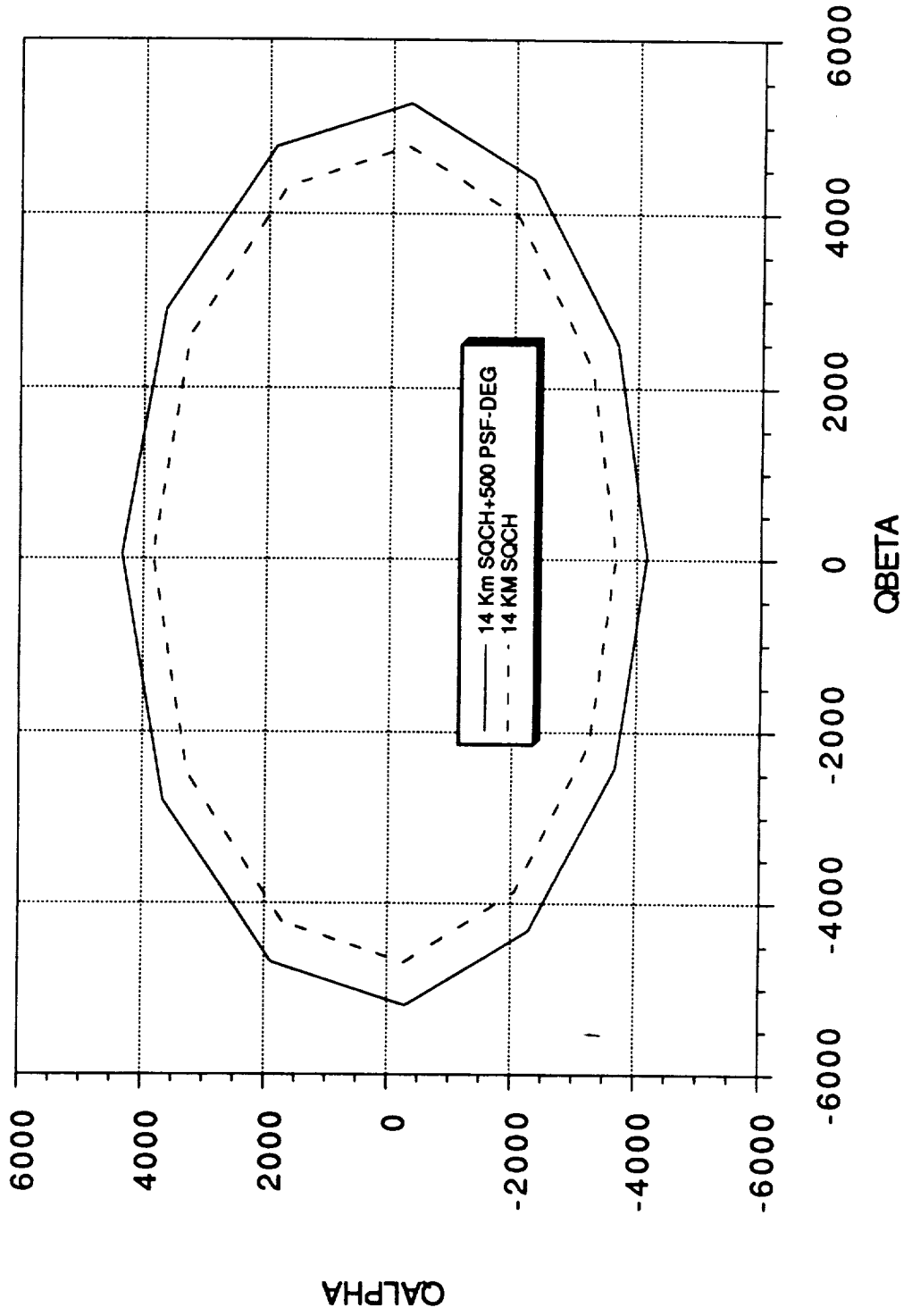

NLS2 Engine Out @ Liftoff 6 Km winds with No Load Relief

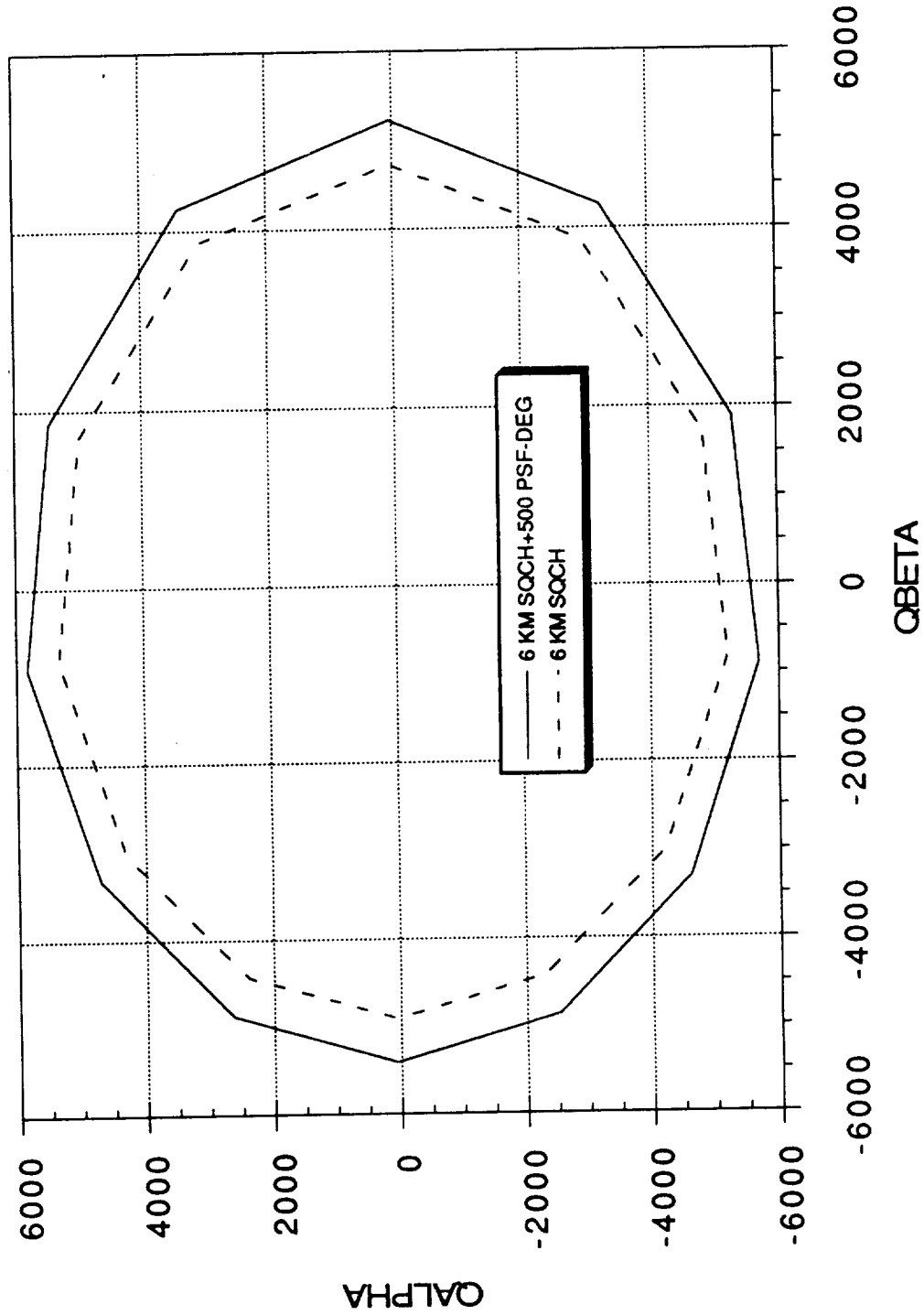

**NLS2 Engine Out @ Liftoff
8 Km winds with No Load Relief**

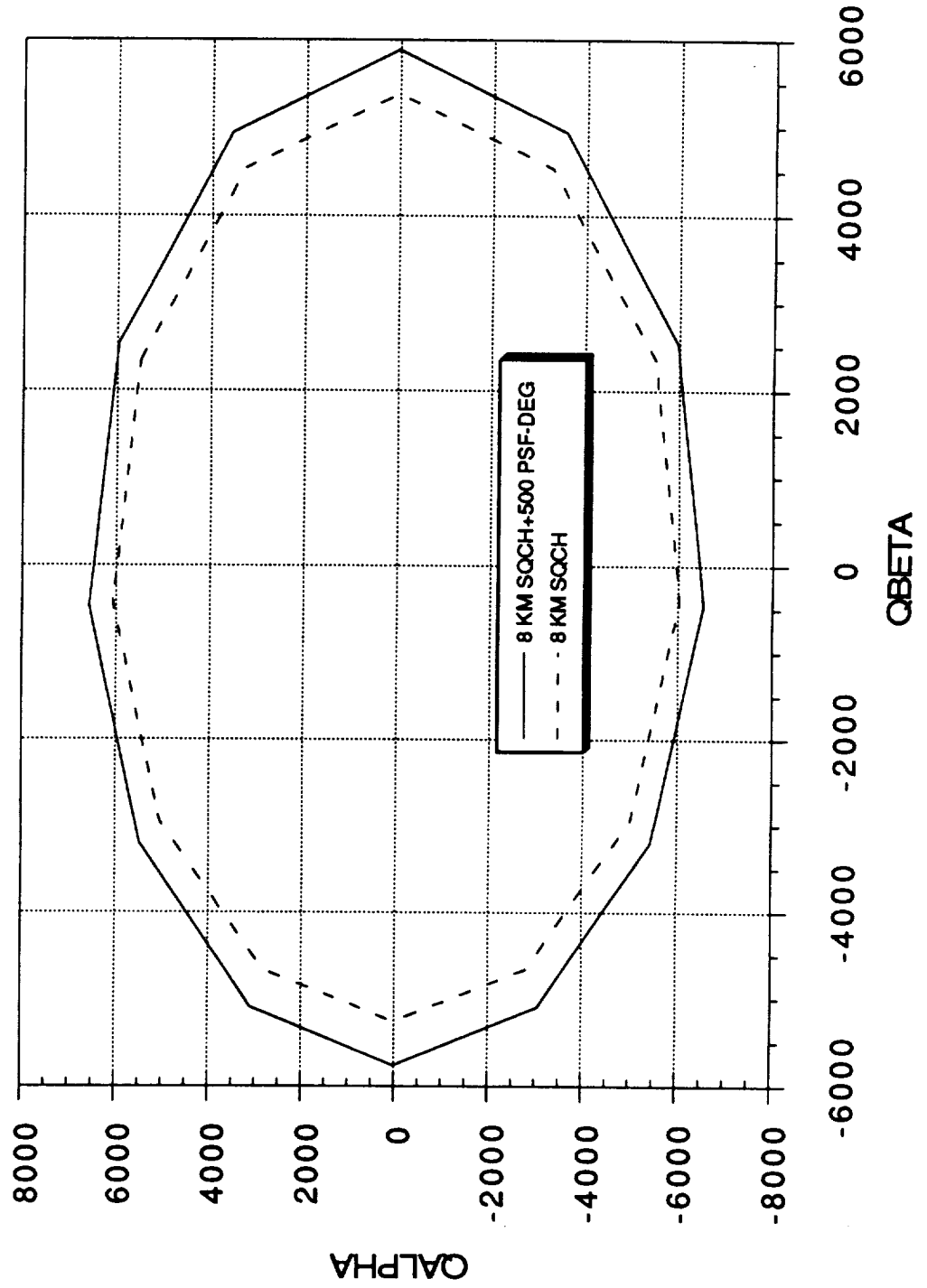

NLS2 Engine Out @ Liftoff 10 Km Winds with No Load Relief

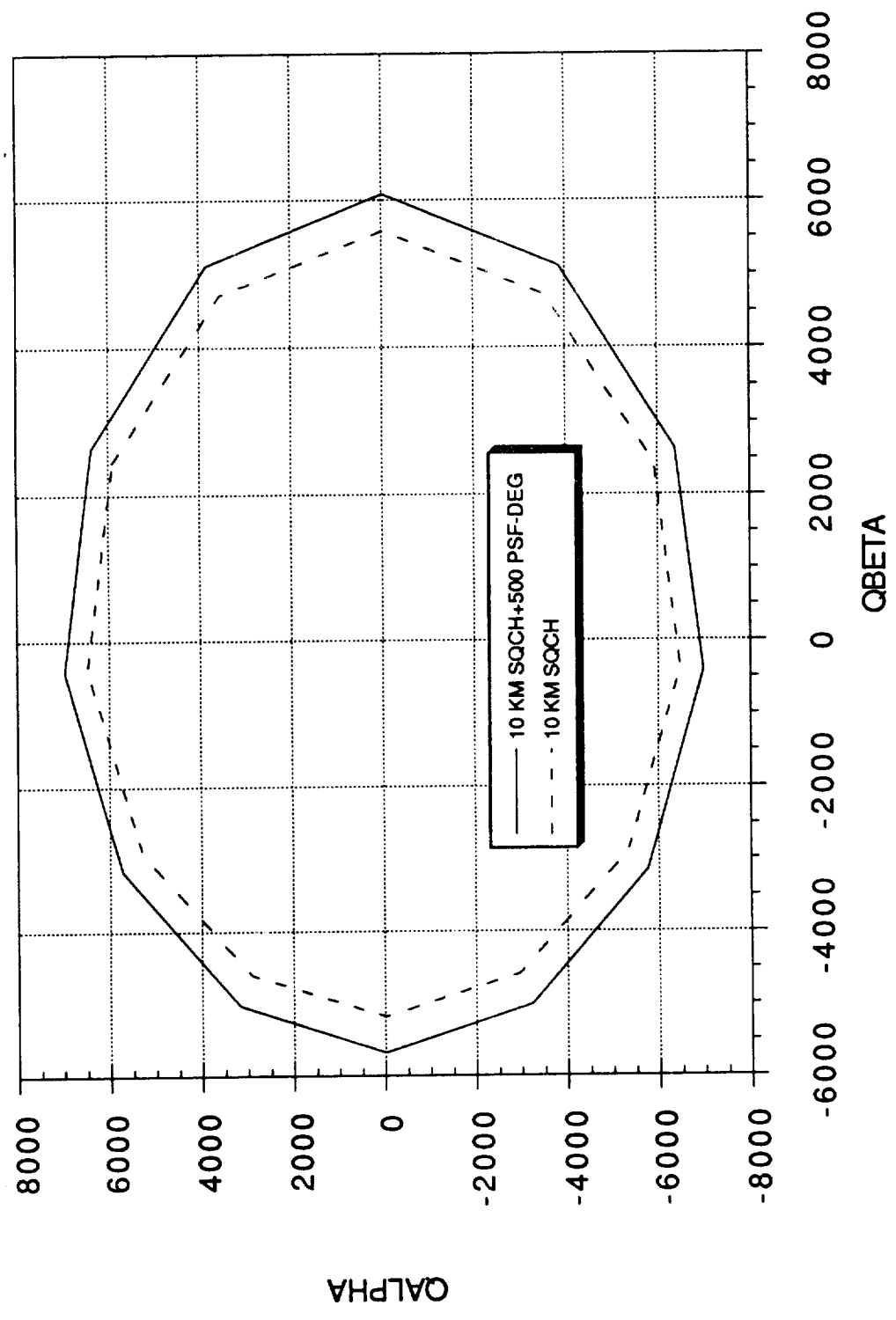

NLS2 Engine Out @ Liftoff 12 Km Winds with No Load Relief

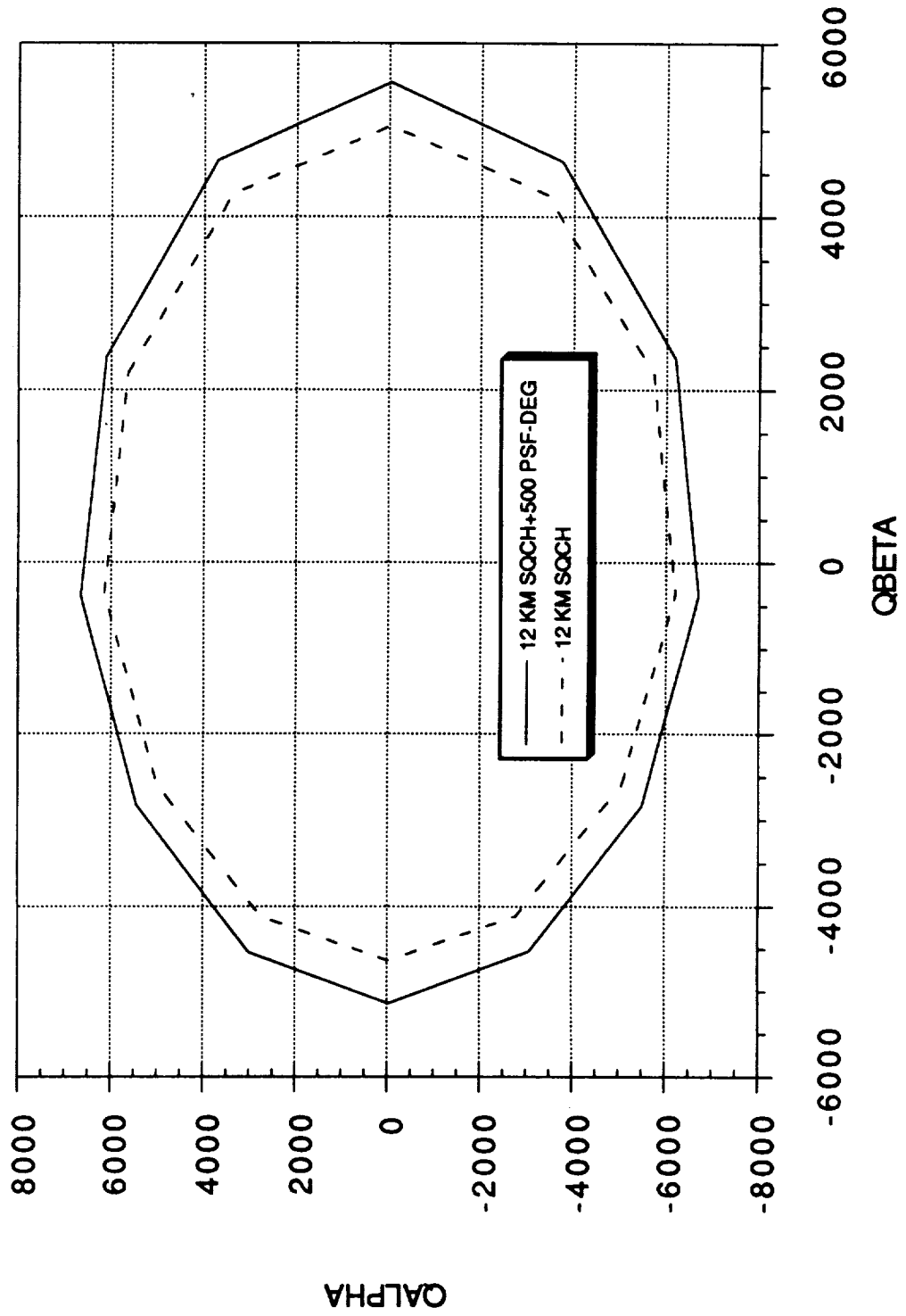

NLS2 Engine Out @ Liftoff 13 Km Winds with No Load Relief

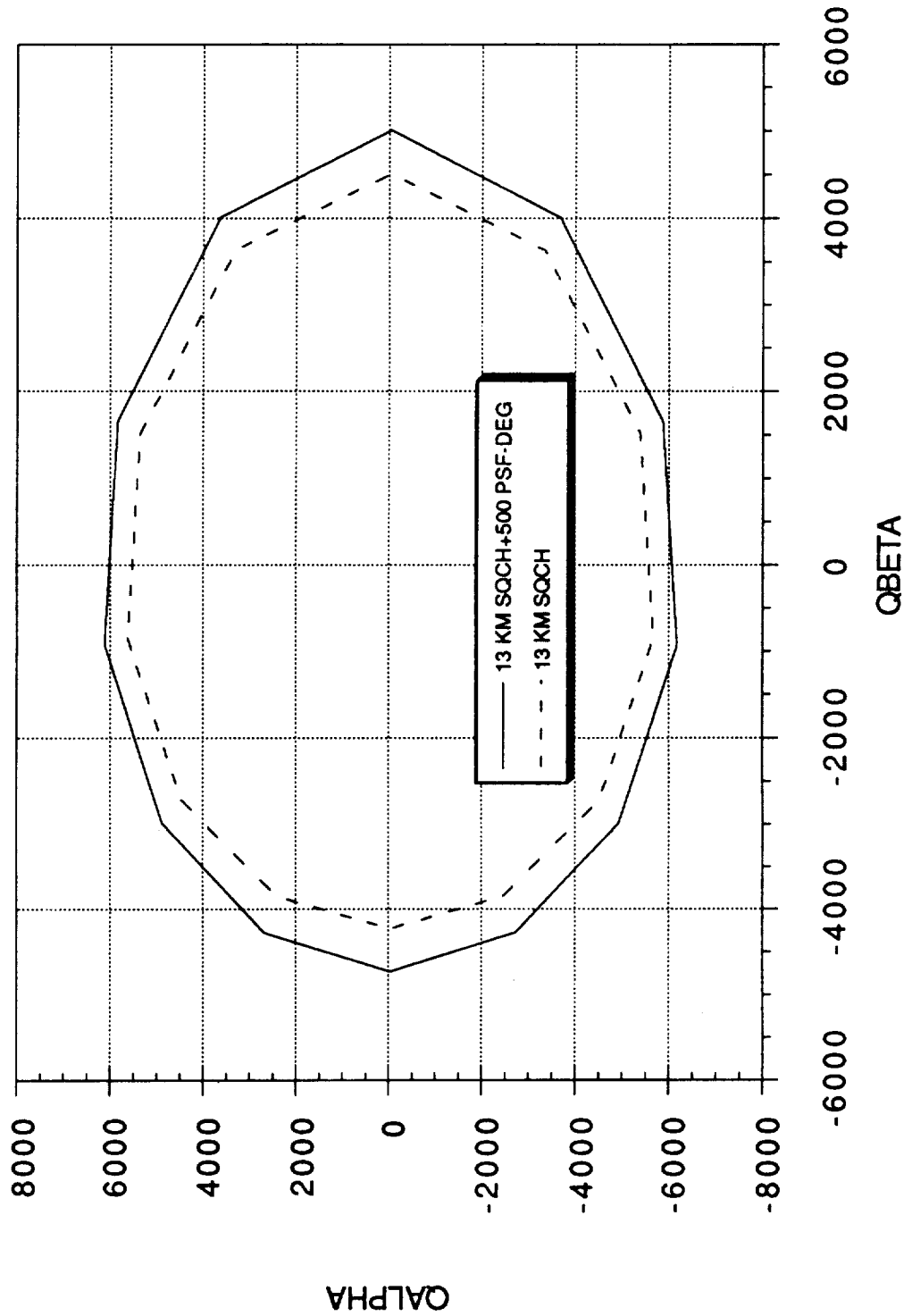

**NLS2 Engine Out @ Liftoff
14 Km Winds with No Load Relief**

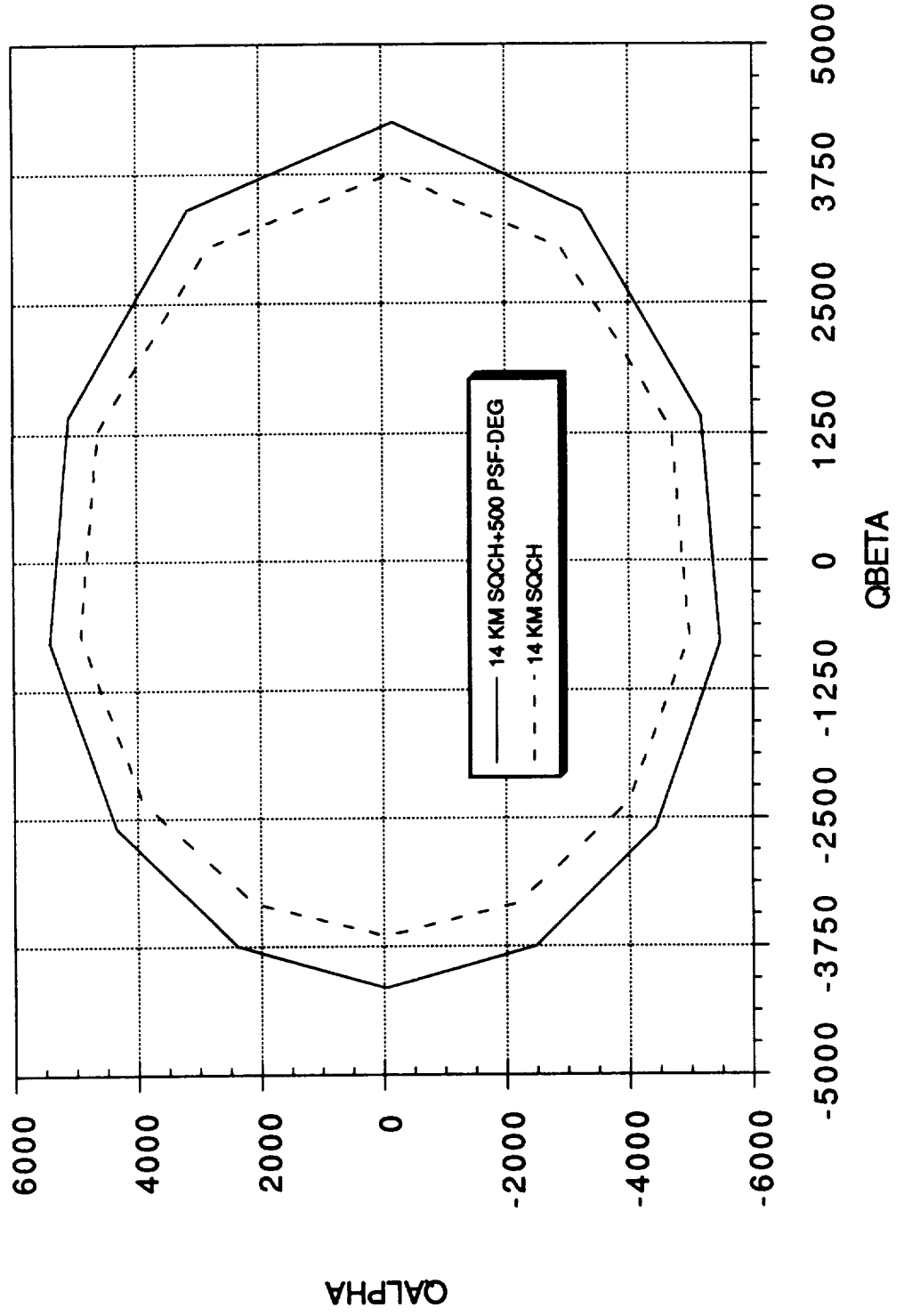

**NLS1 CORE - ASCENT
OVERALL MAXIMUM NX**

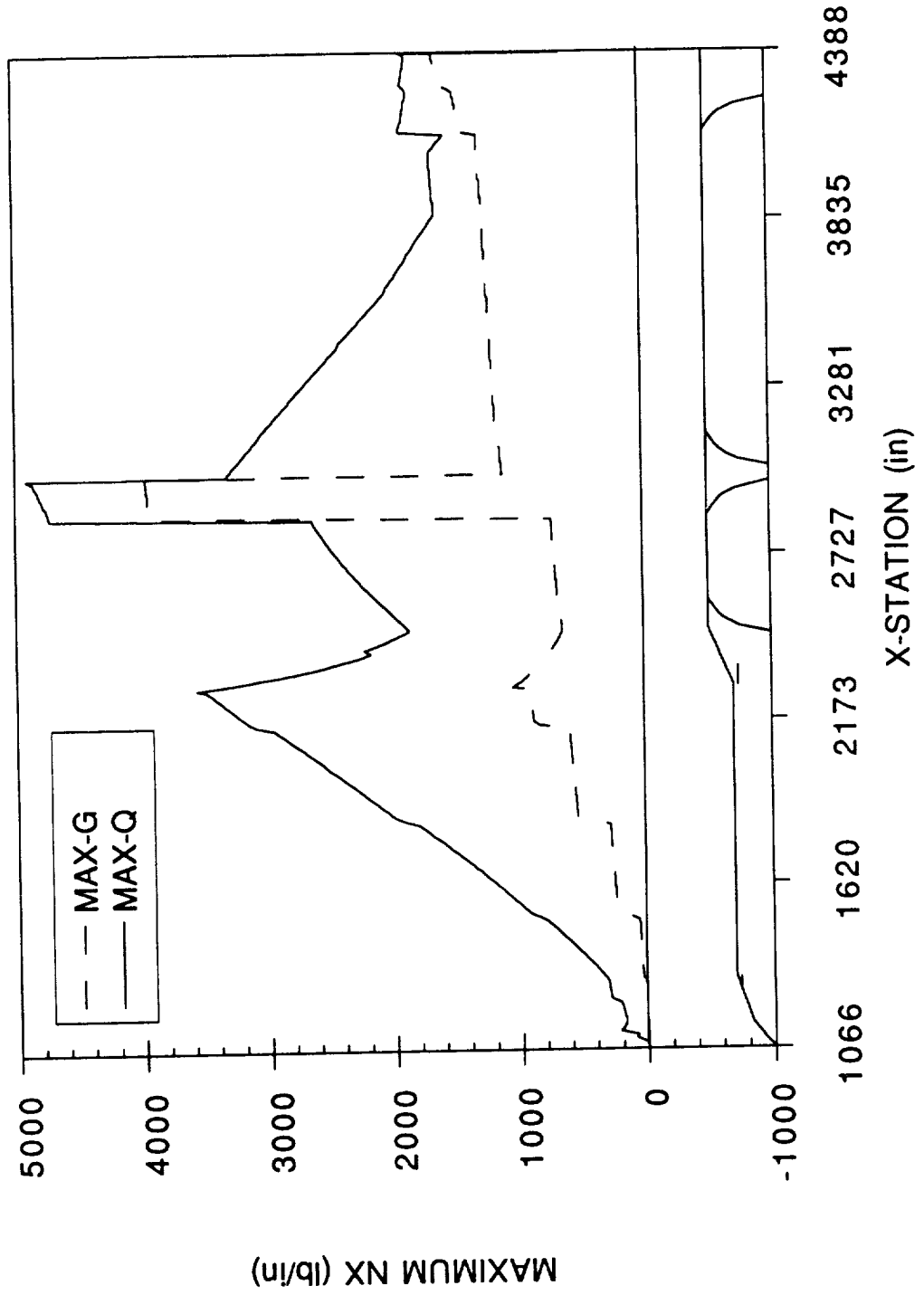

**NLS1 CORE - ASCENT
OVERALL MAXIMUM NV**

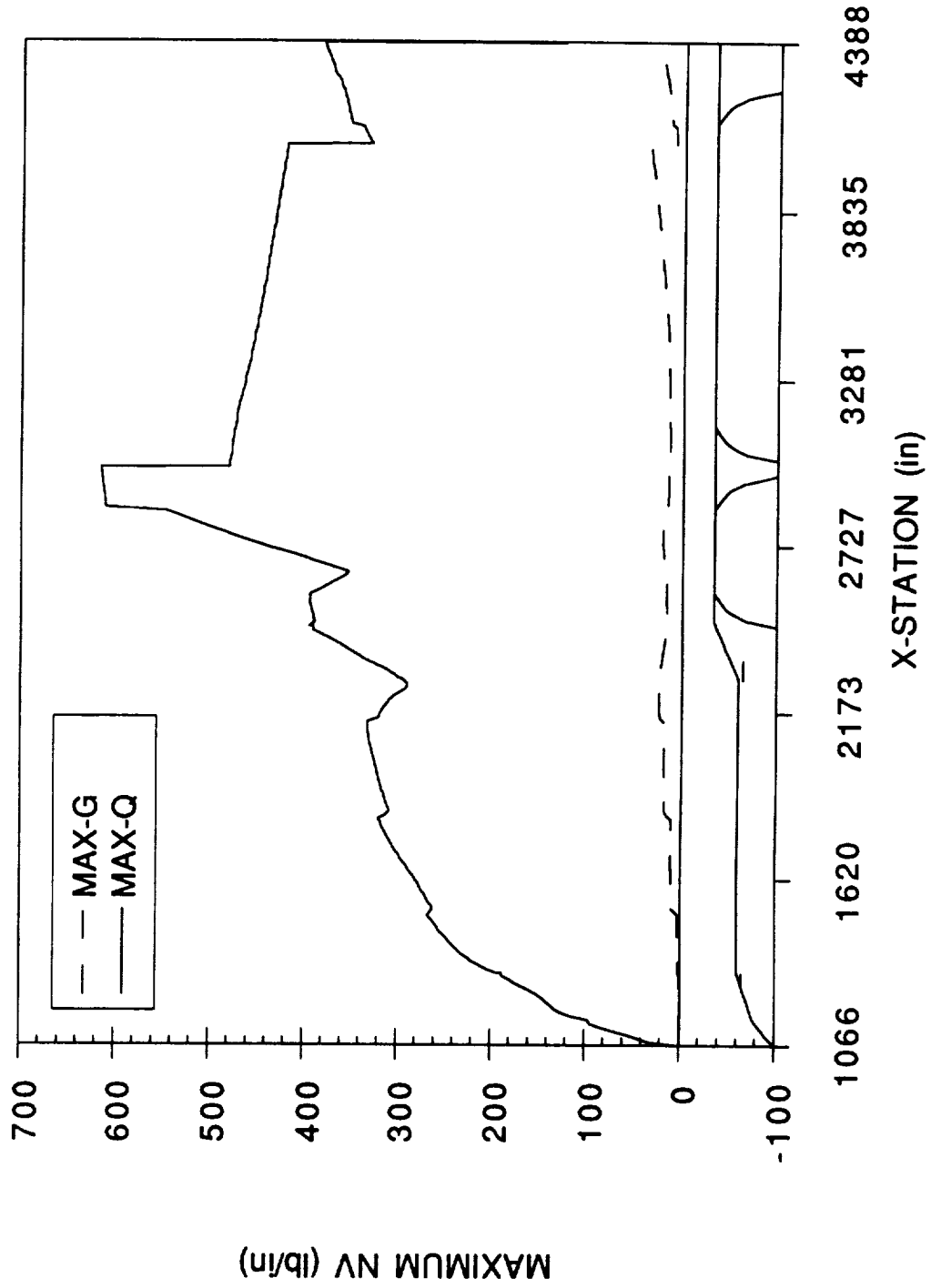

**NLS1 CORE - ASCENT
OVERALL MAXIMUM P EQUIVALENT**

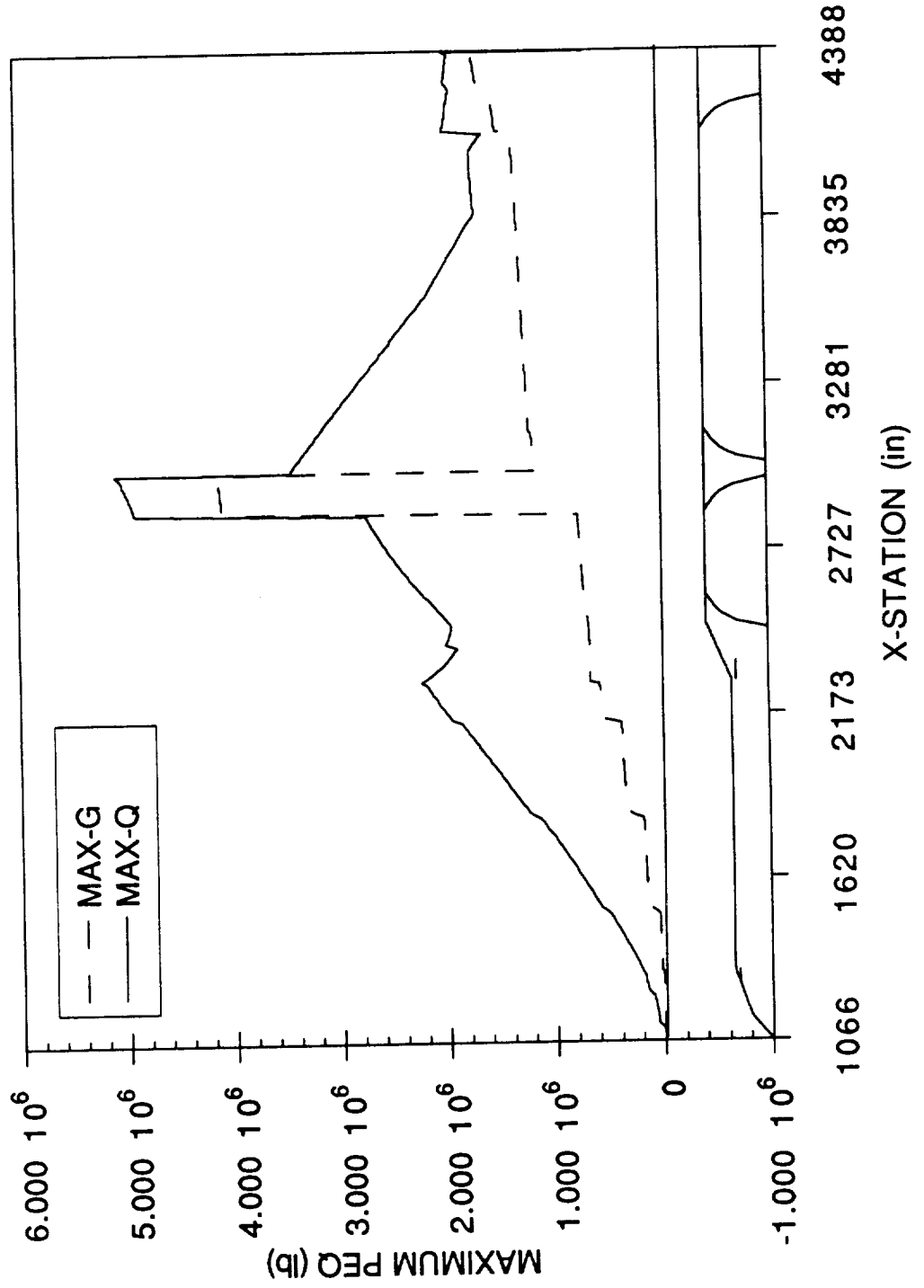

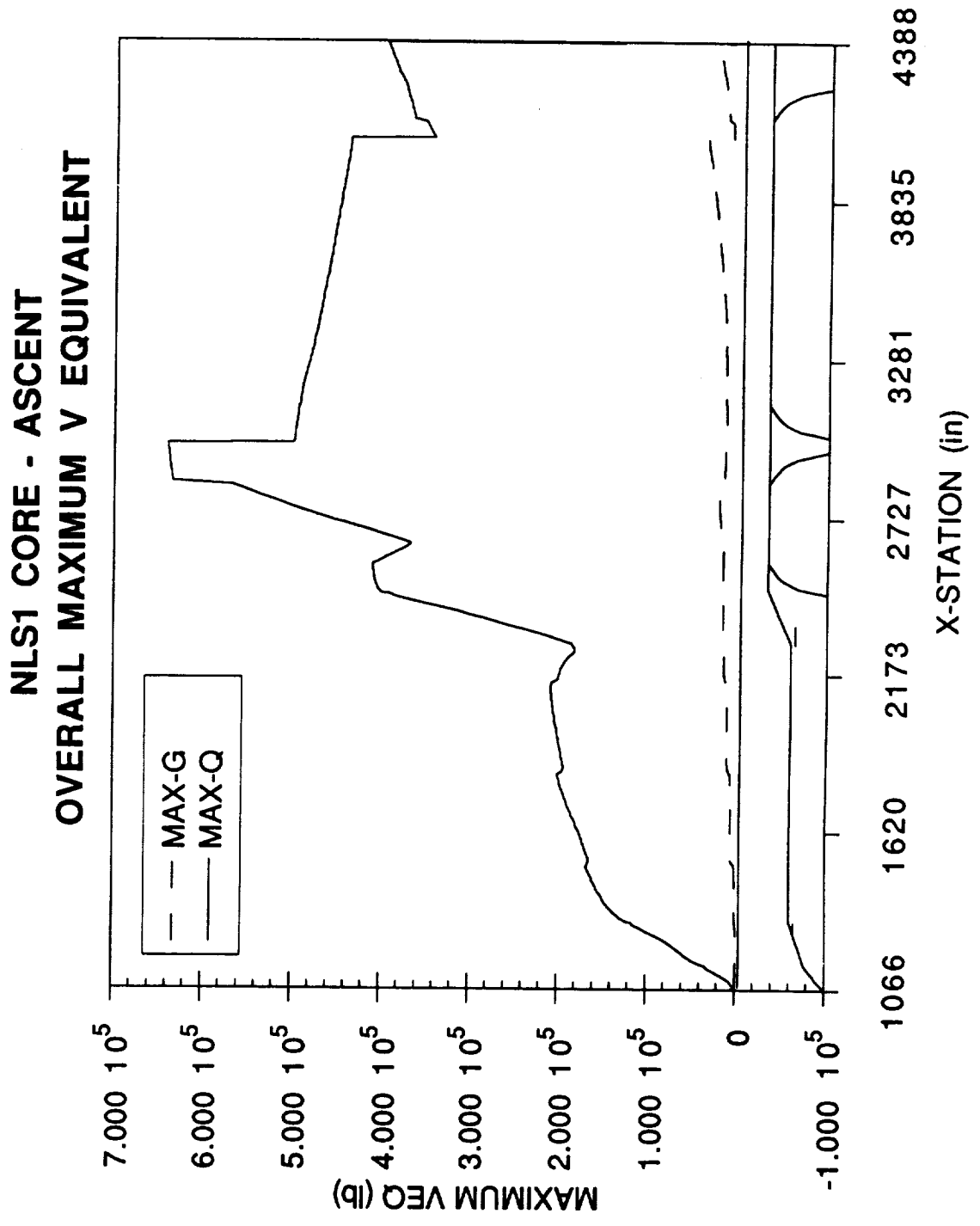

(

(

(

**NLS1 CORE - ASCENT
OVERALL MAXIMUM AXIAL SHEAR**

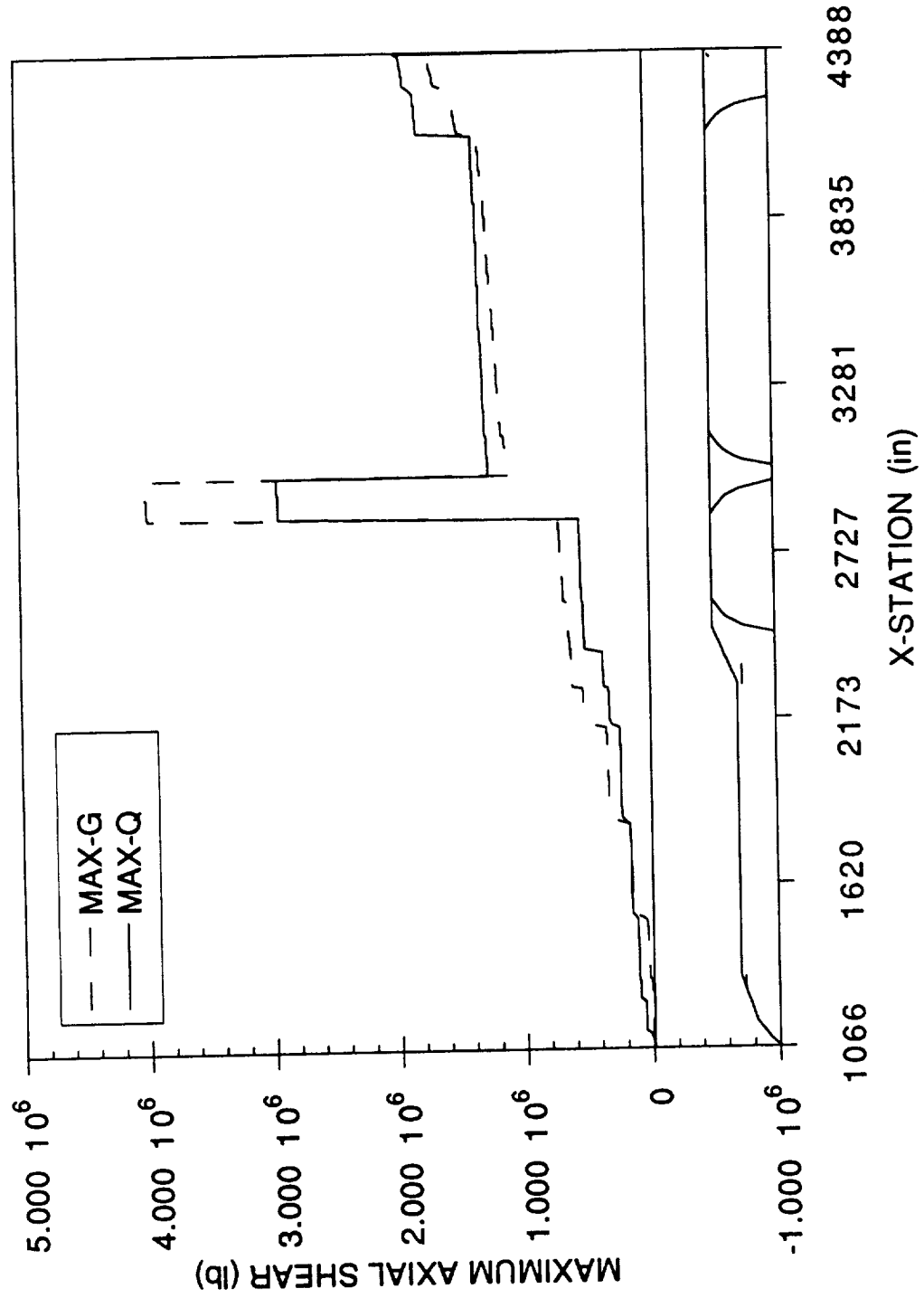

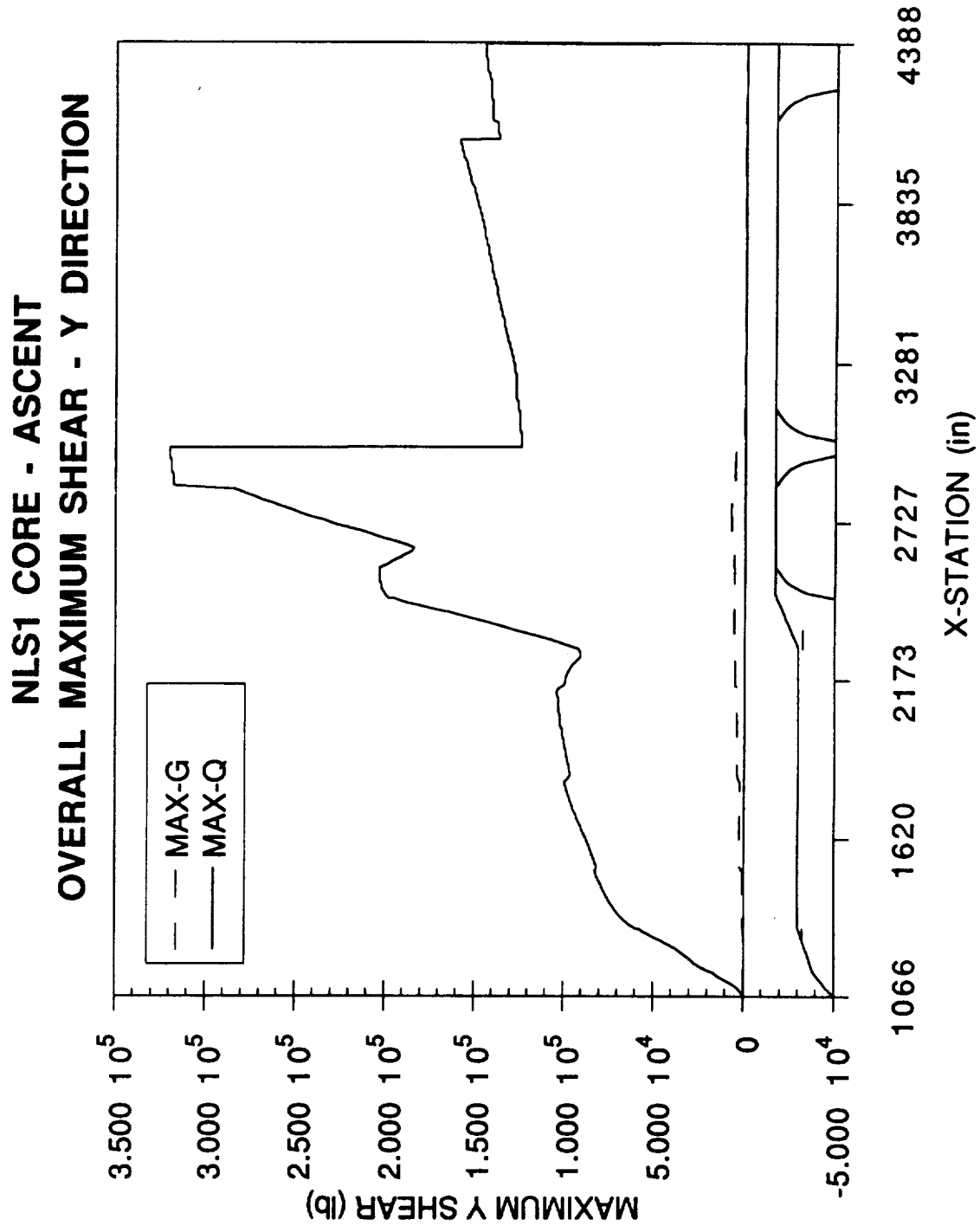

((

**NLS1 CORE - ASCENT
OVERALL MAXIMUM SHEAR - Z DIRECTION**

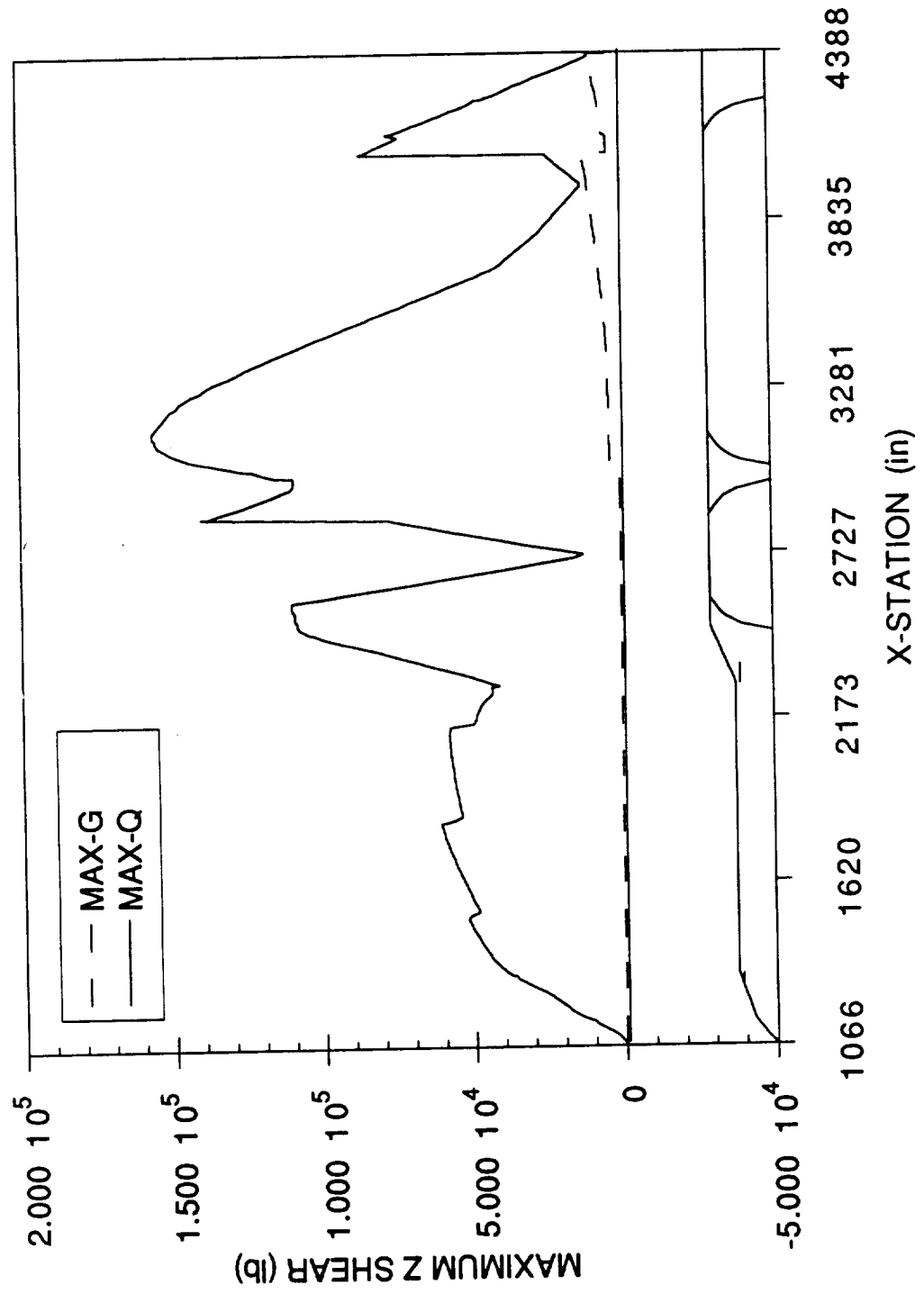

**NLS1 CORE - ASCENT
OVERALL MAXIMUM MOMENT - Y DIRECTION**

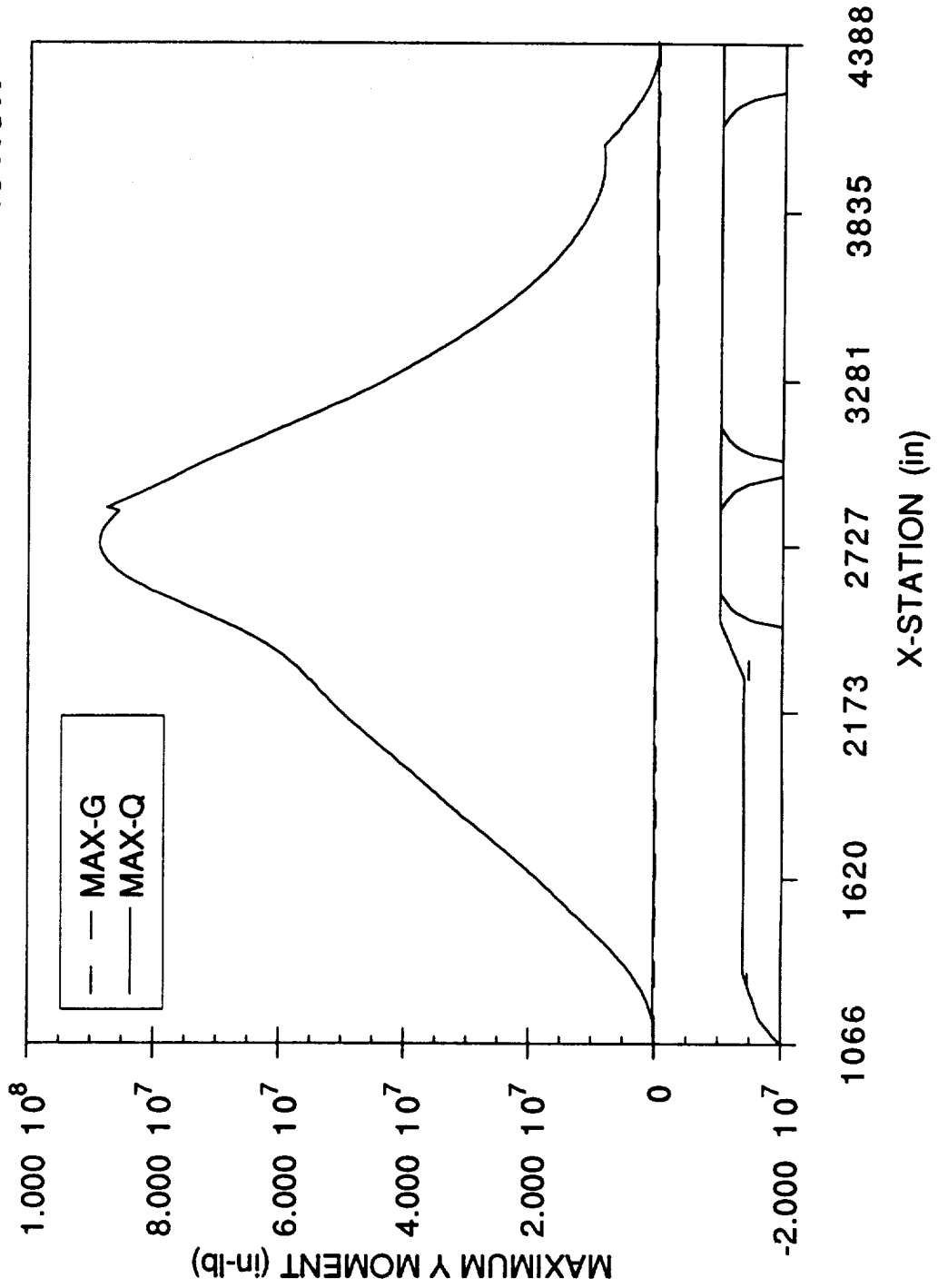

**NLS1 CORE - ASCENT
OVERALL MAXIMUM MOMENT - Z DIRECTION**

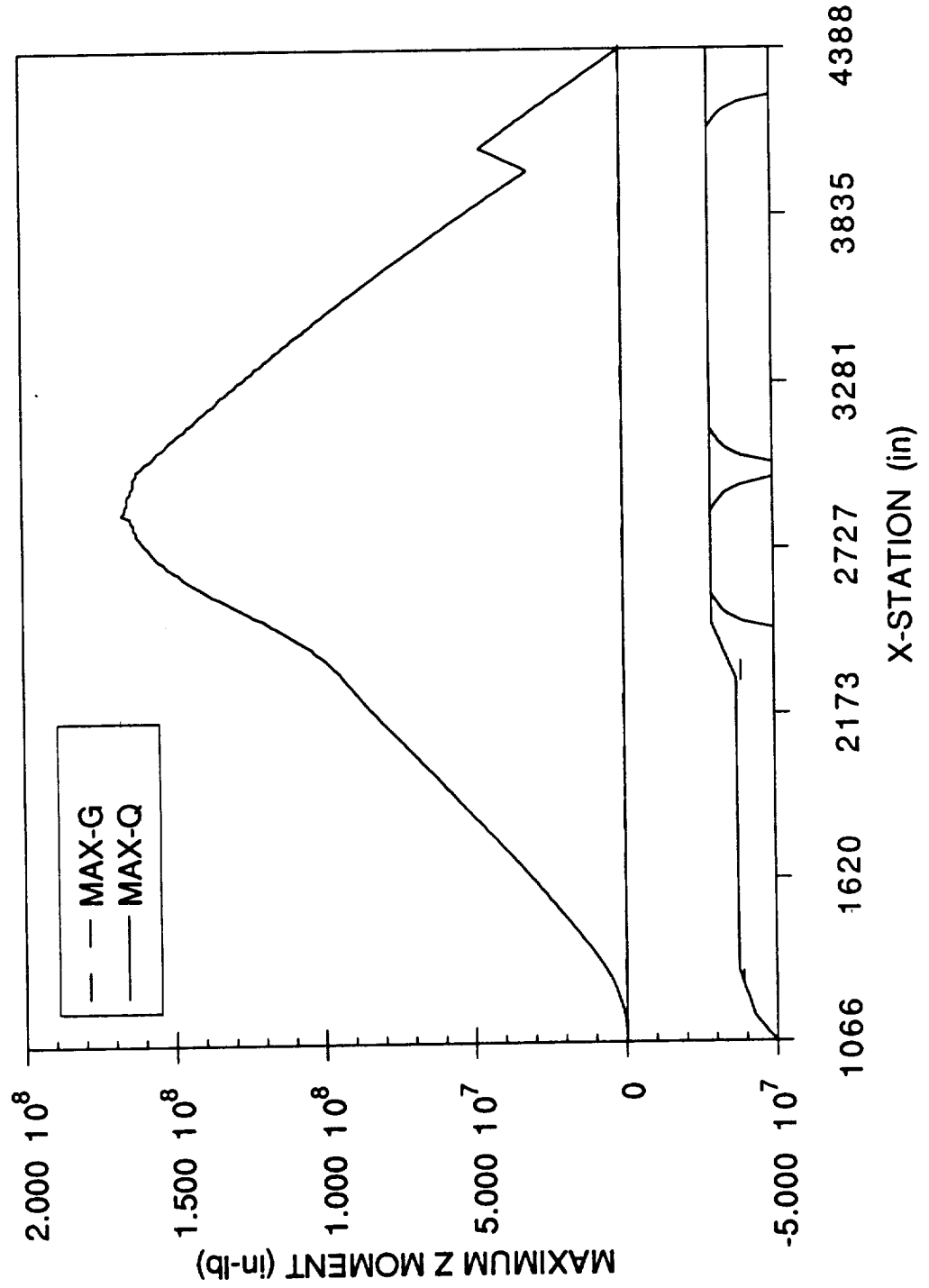

NLS1 CORE - 3 km NX vs X-STATION

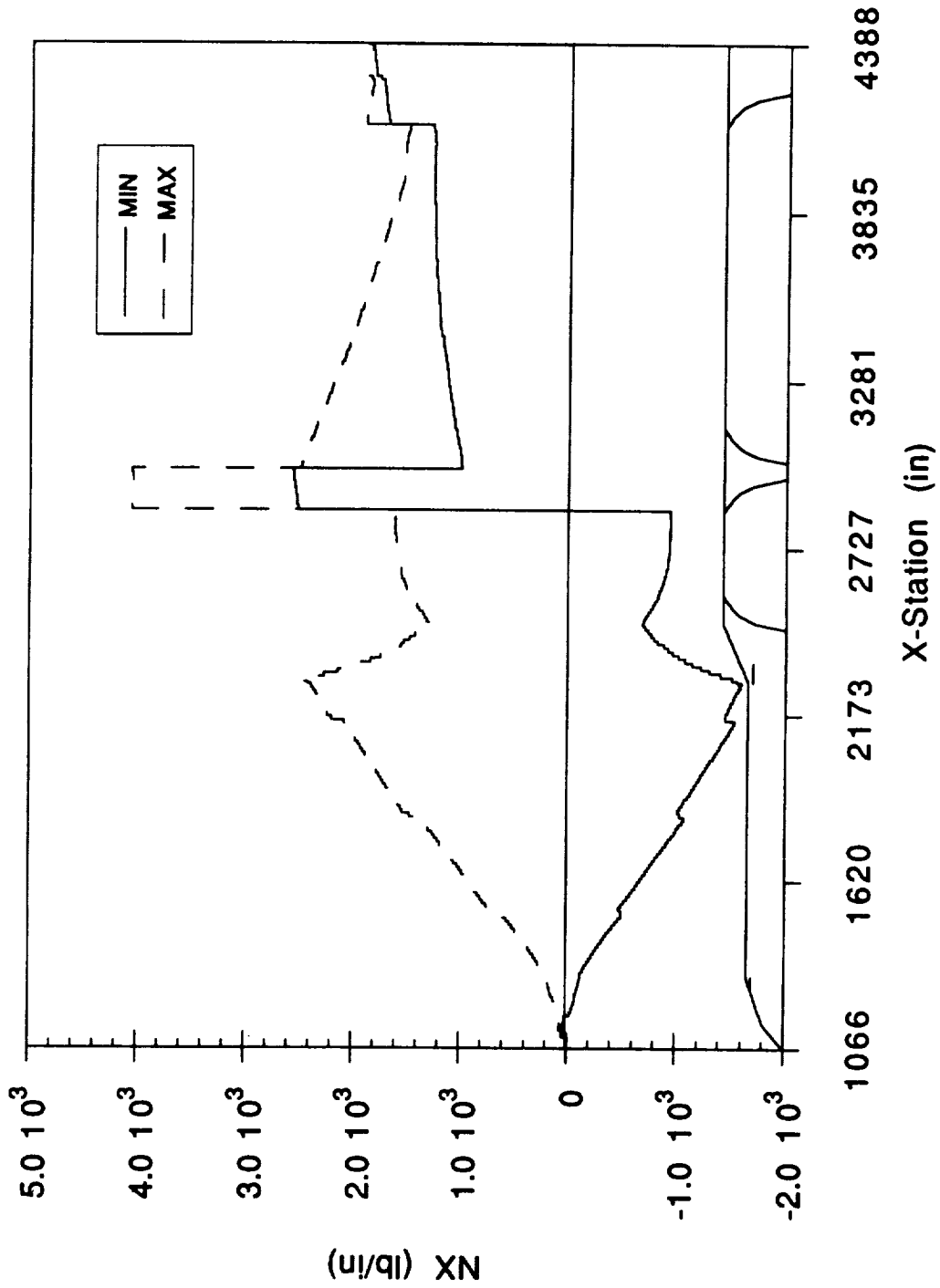

((

**NLS1 CORE - 3 km
NV vs X-STATION**

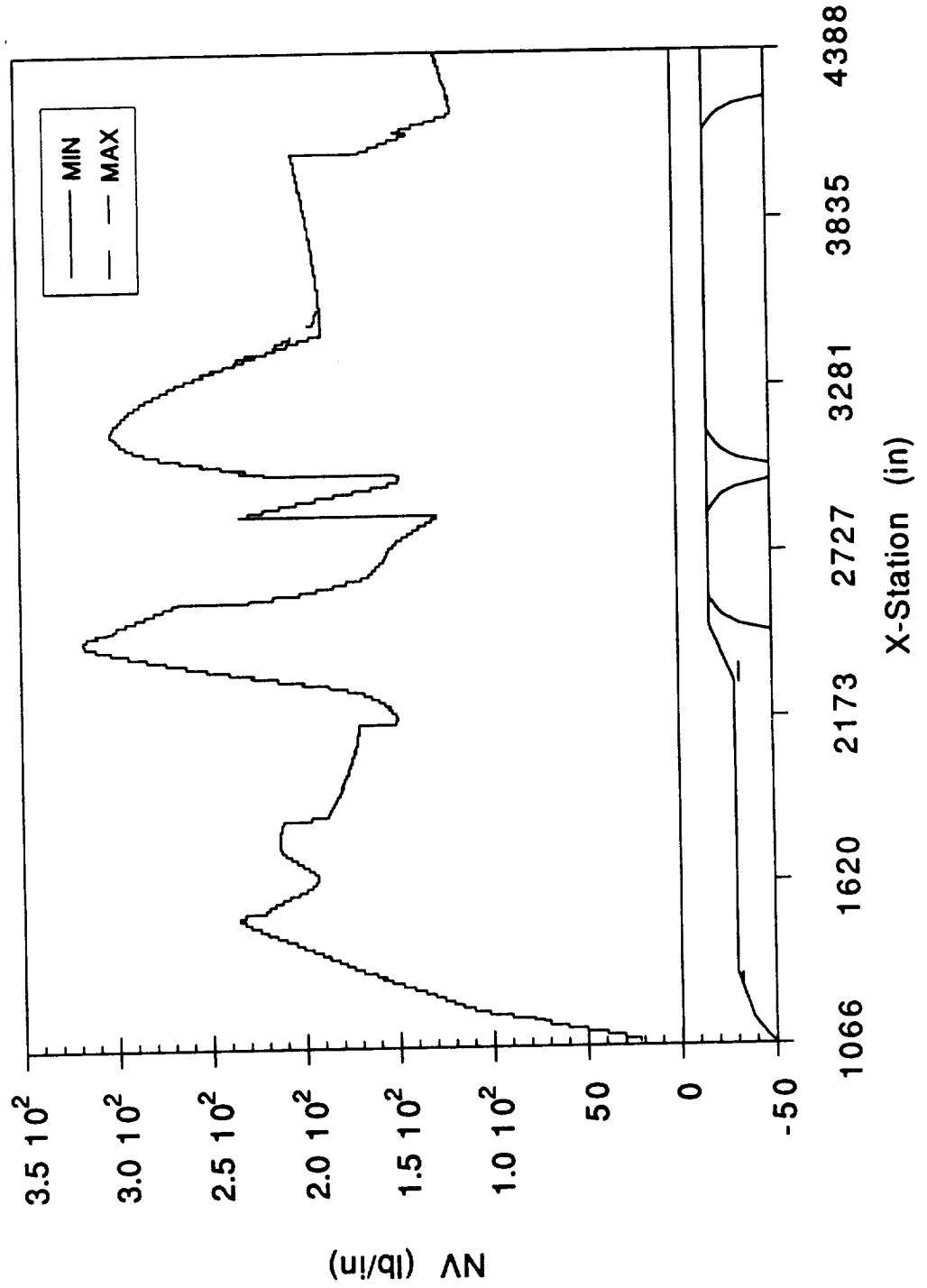

**NLS1 CORE - 3 km
AXIAL SHEAR VS X-STATION**

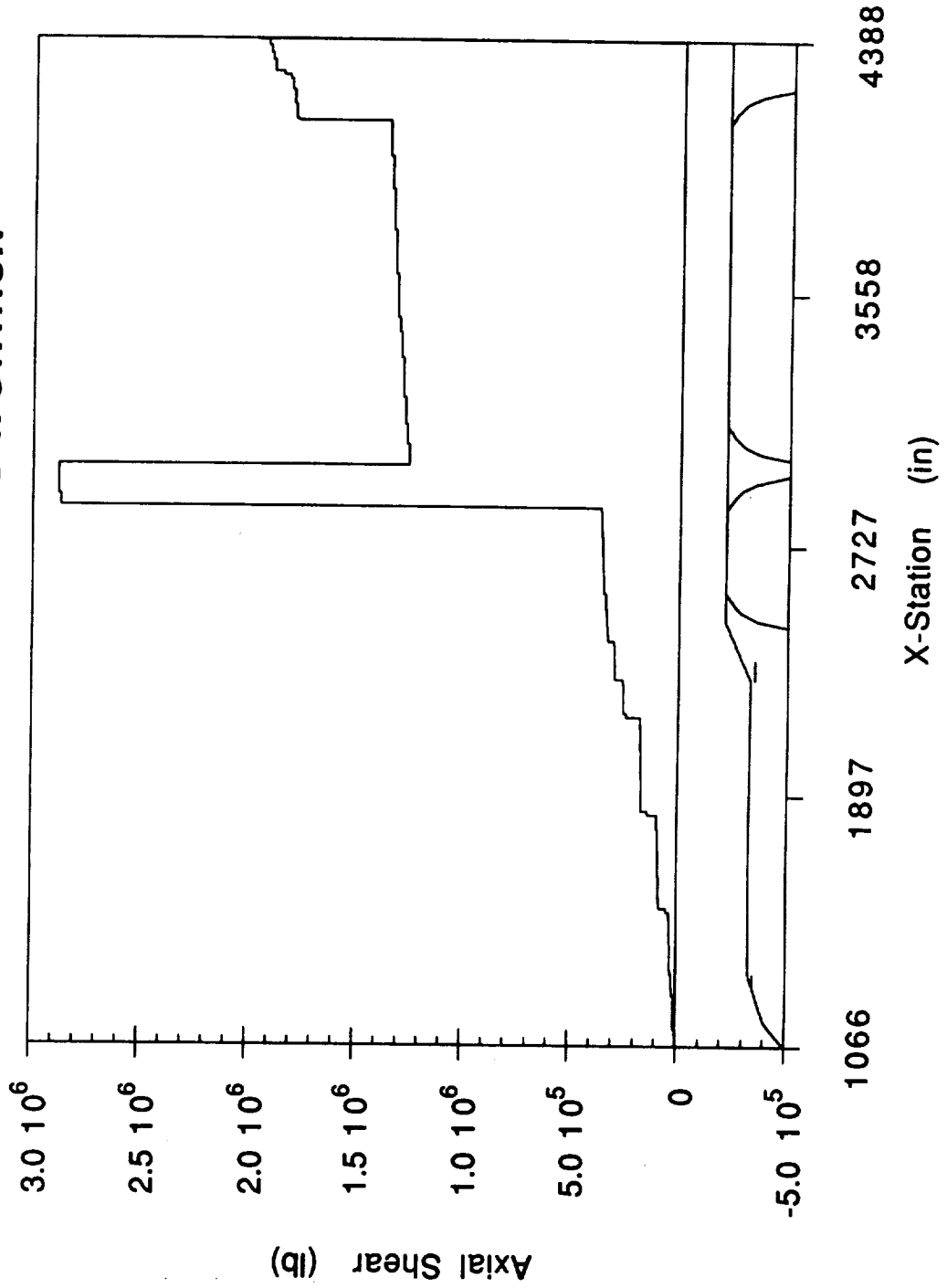

(((

**NLS1 CORE - 3 km
Y-DIR SHEAR vs X-STATION**

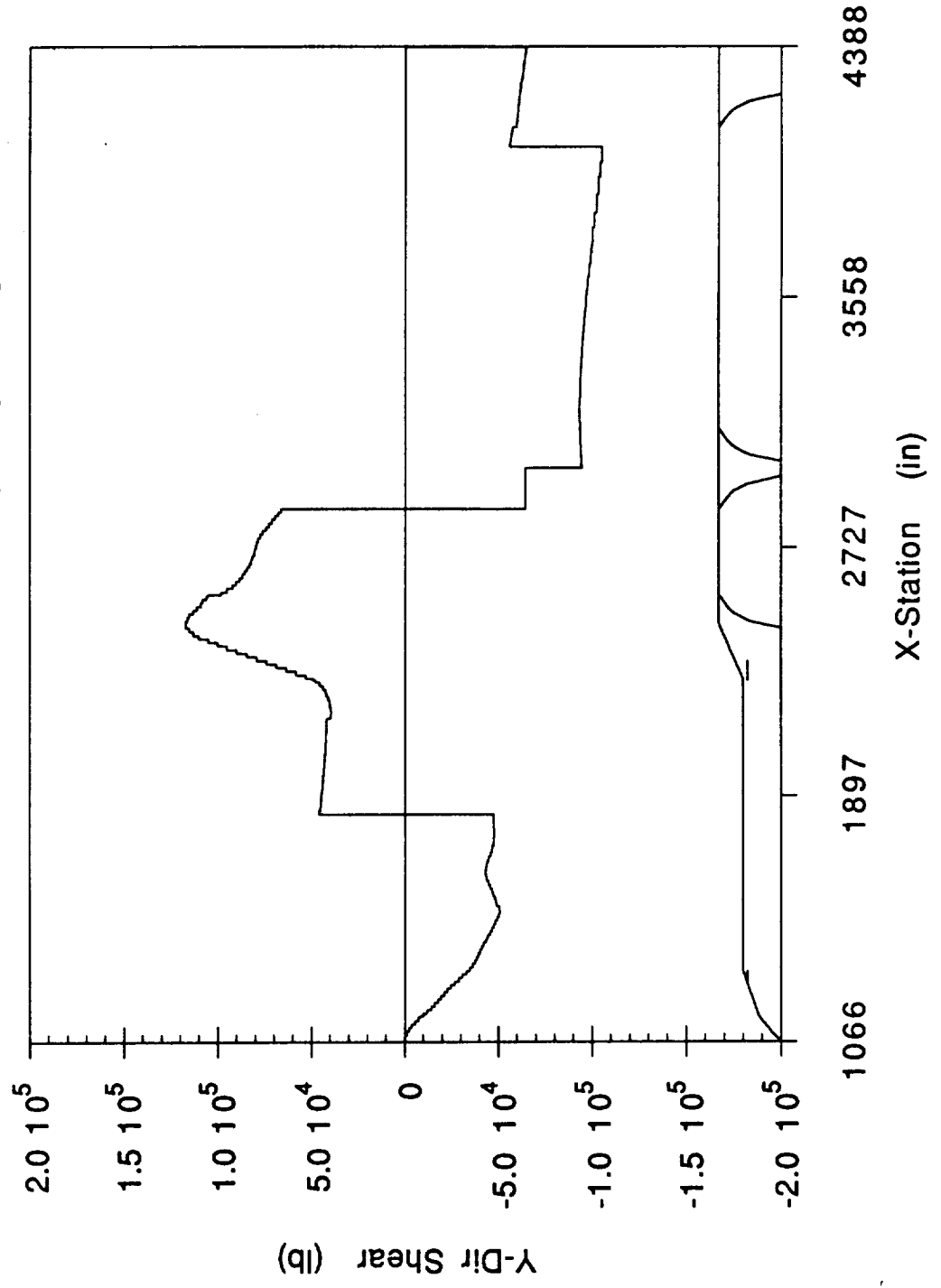

**NLS1 CORE - 3 km
Z-DIR SHEAR vs X-STATION**

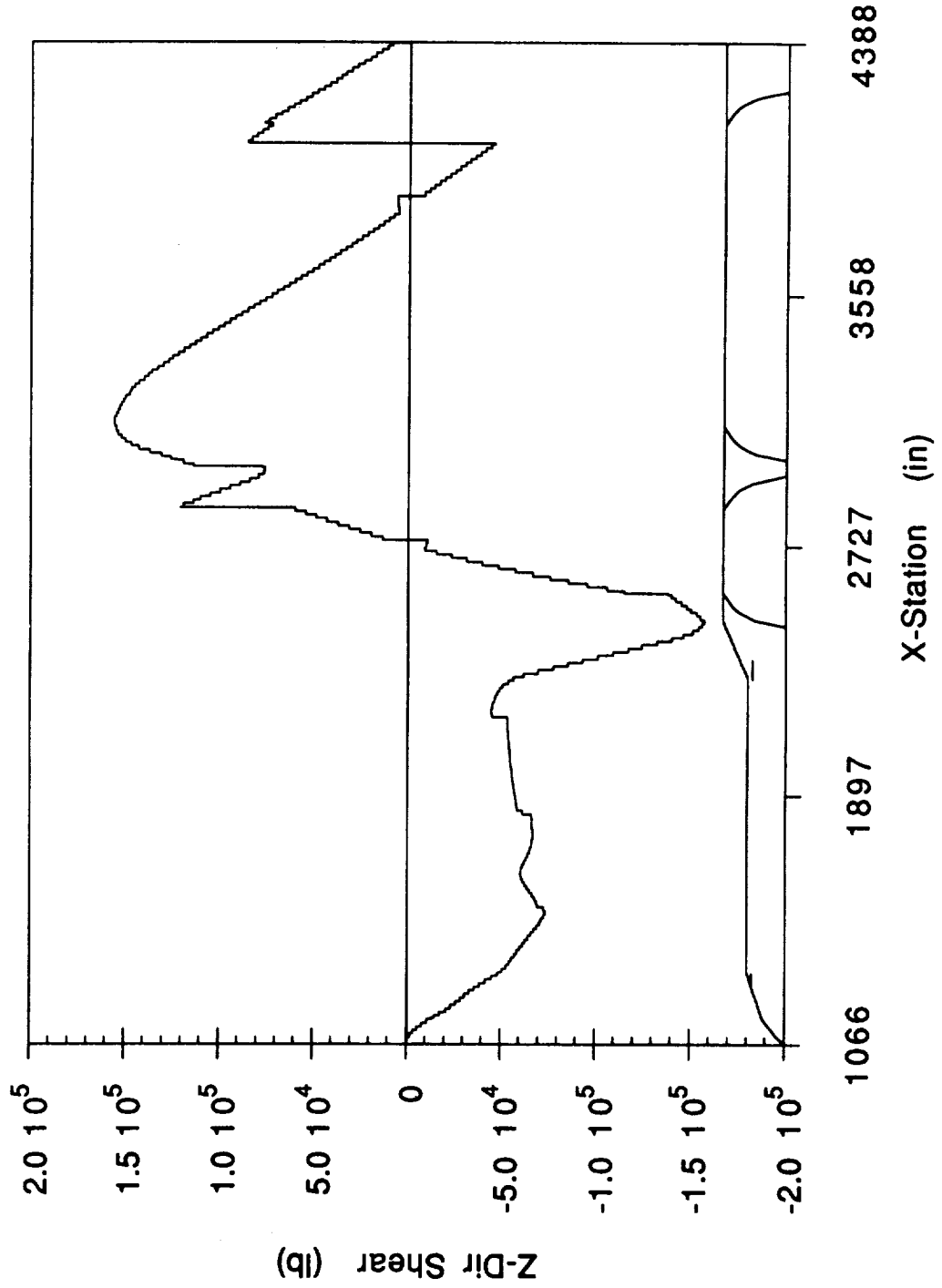

**NLS1 CORE - 3 km
Y-DIR MOMENT vs X-STATION**

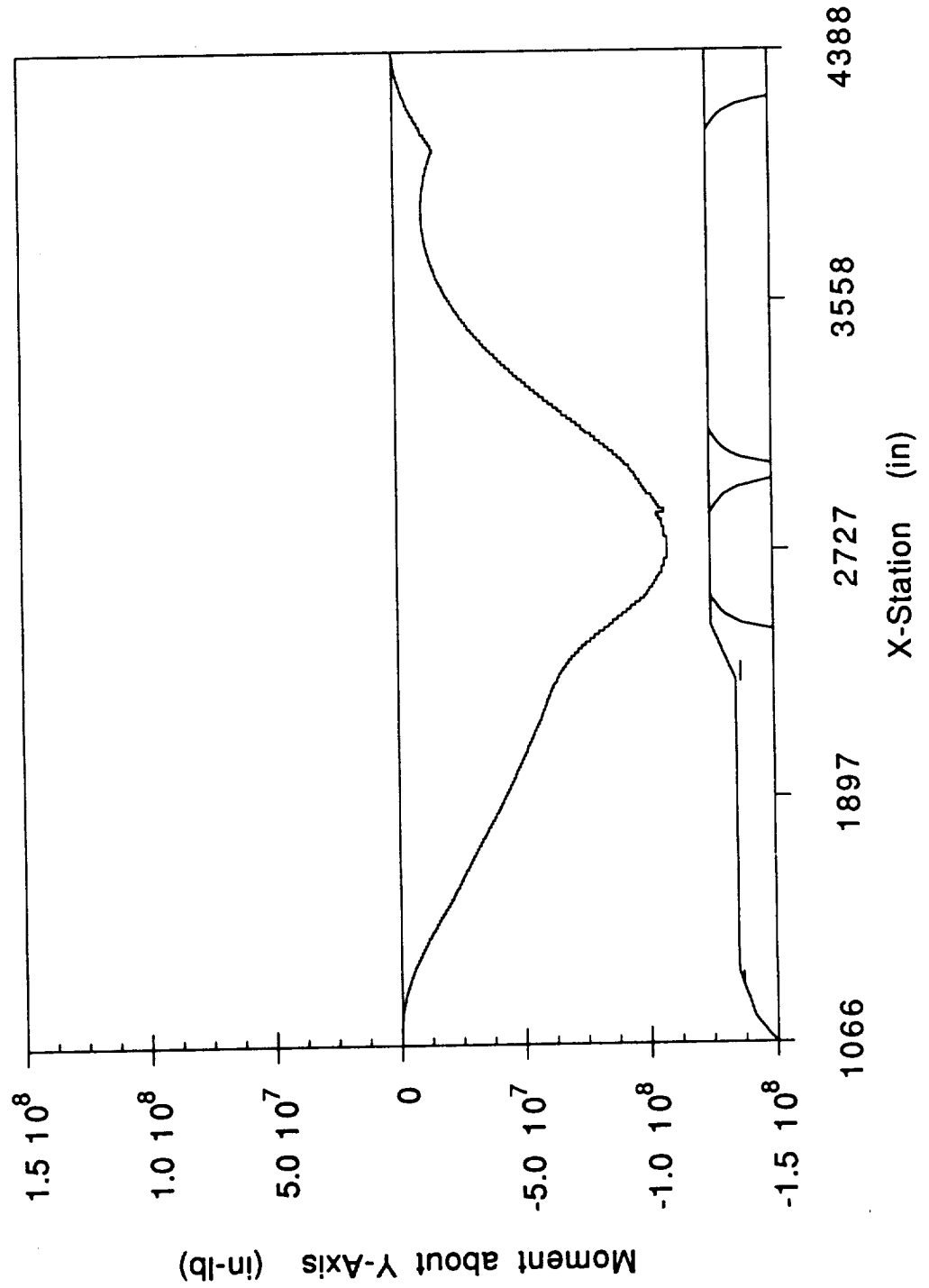

**NLS1 CORE - 3 km
Z-DIR MOMENT vs X-STATION**

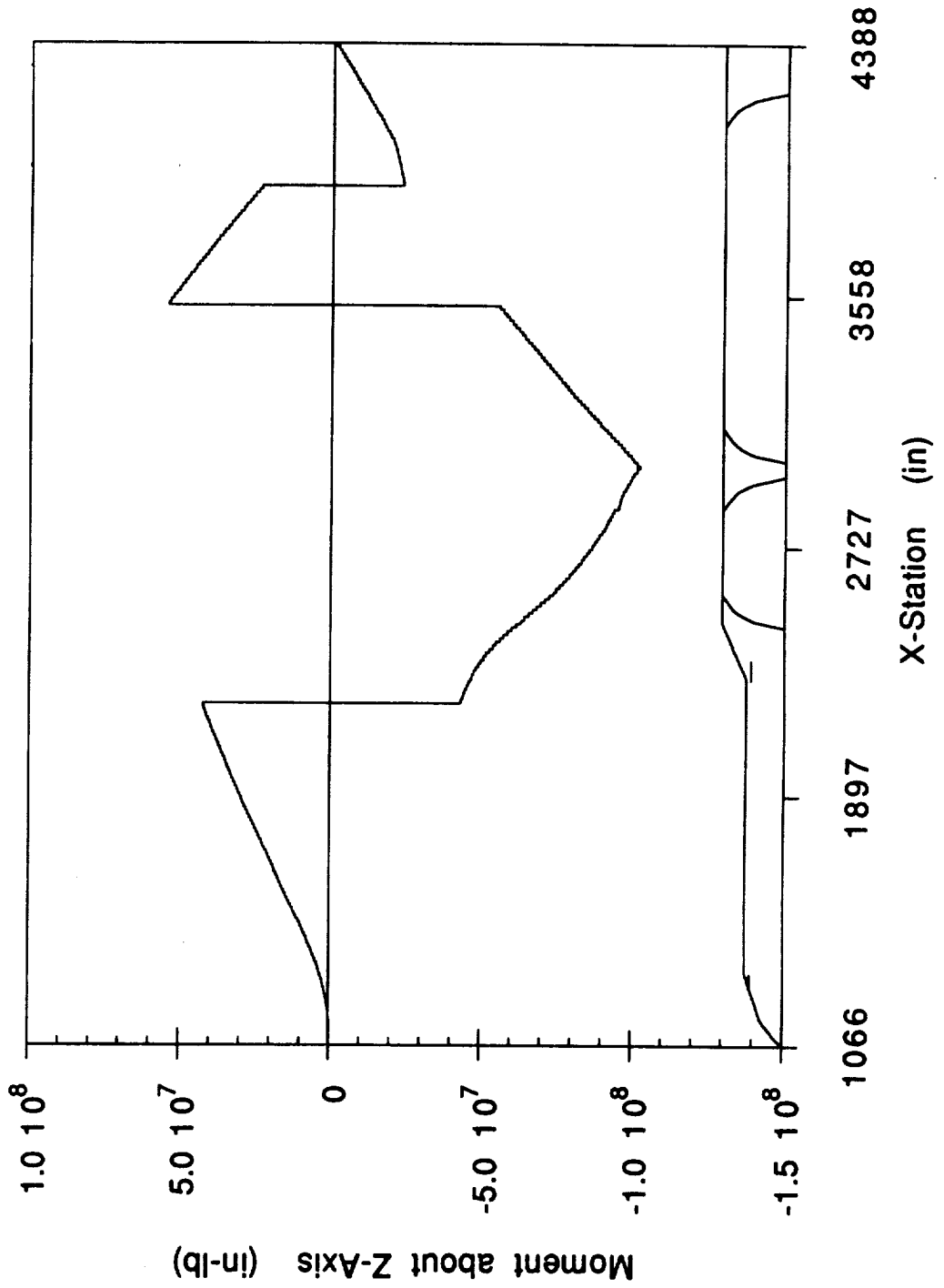

**NLS1 CORE - 4 km
NX vs X-STATION**

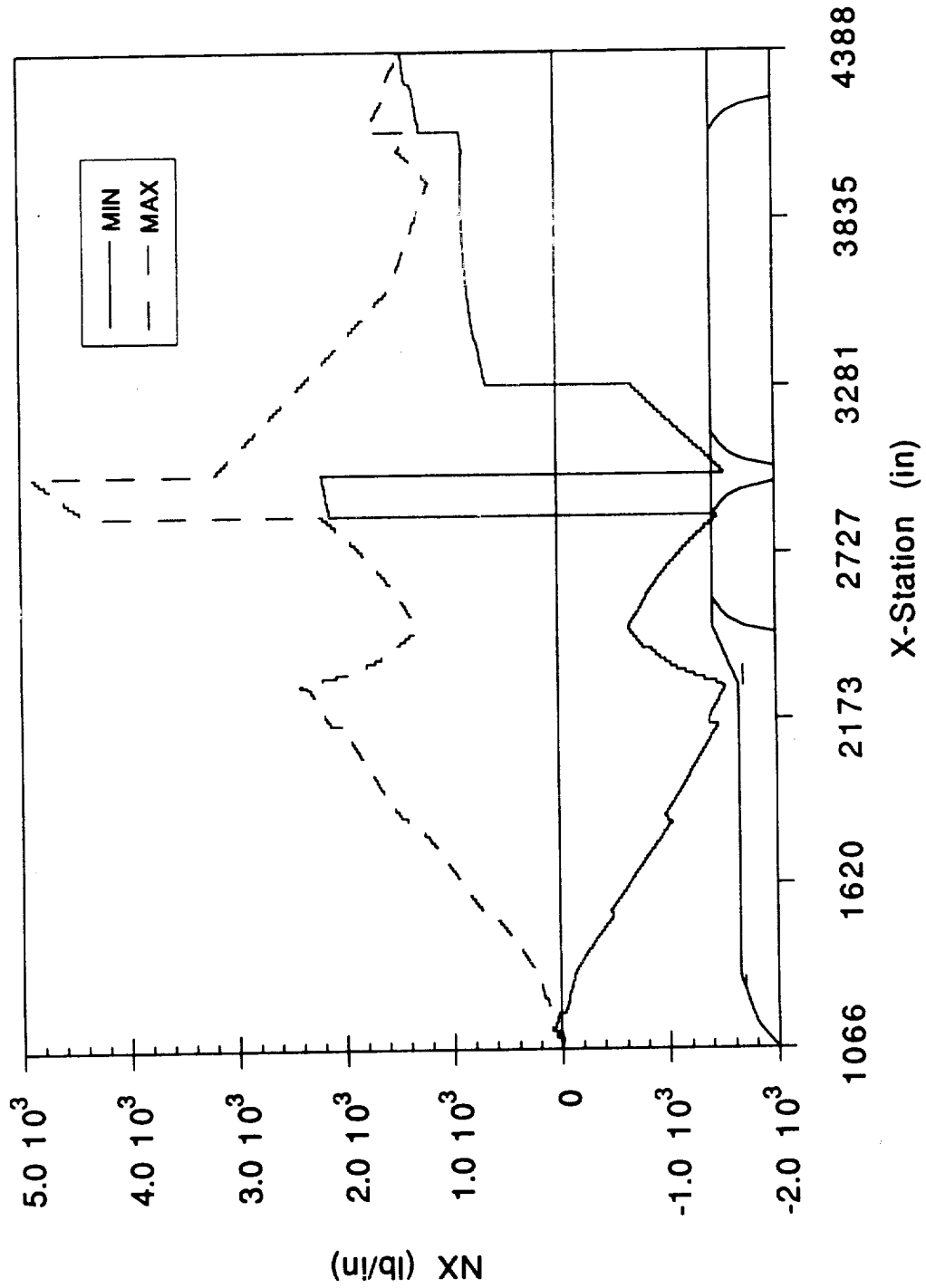

**NLS1 CORE - 4 km
NV vs X-STATION**

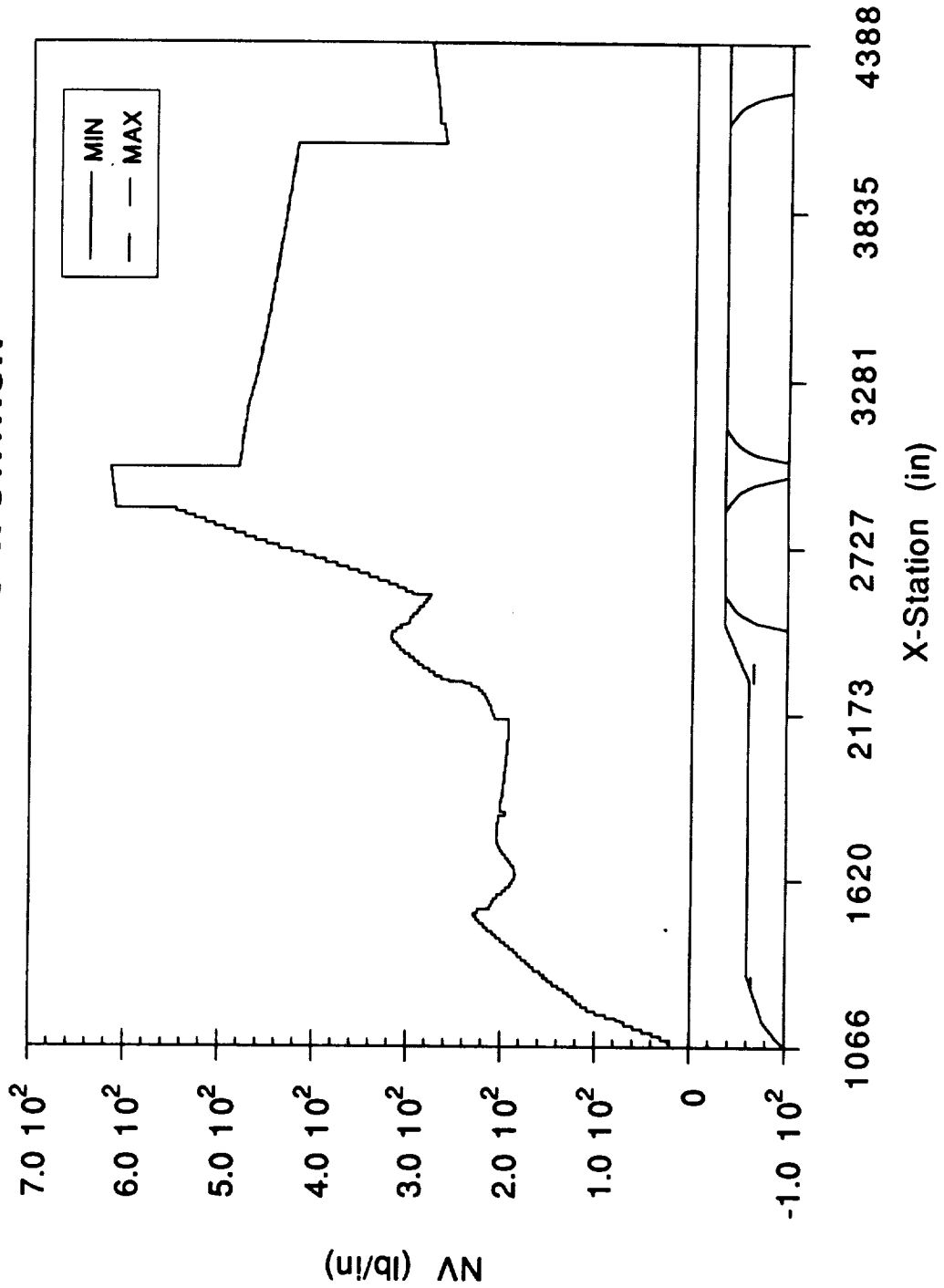

**NLS1 CORE - 4 km
AXIAL SHEAR vs X-STATION**

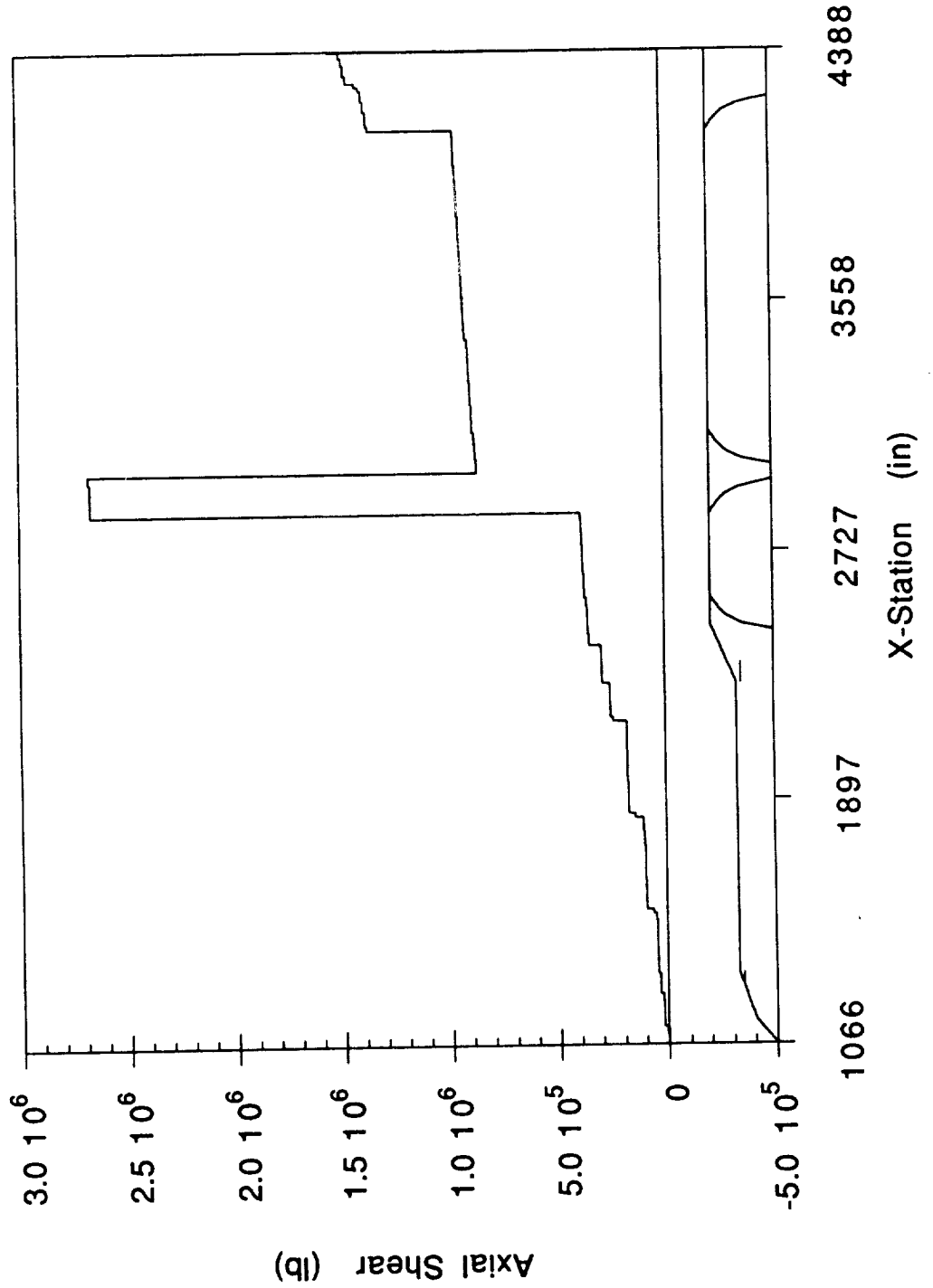

NLS1 CORE - 4 km Y-DIR SHEAR vs X-STATION

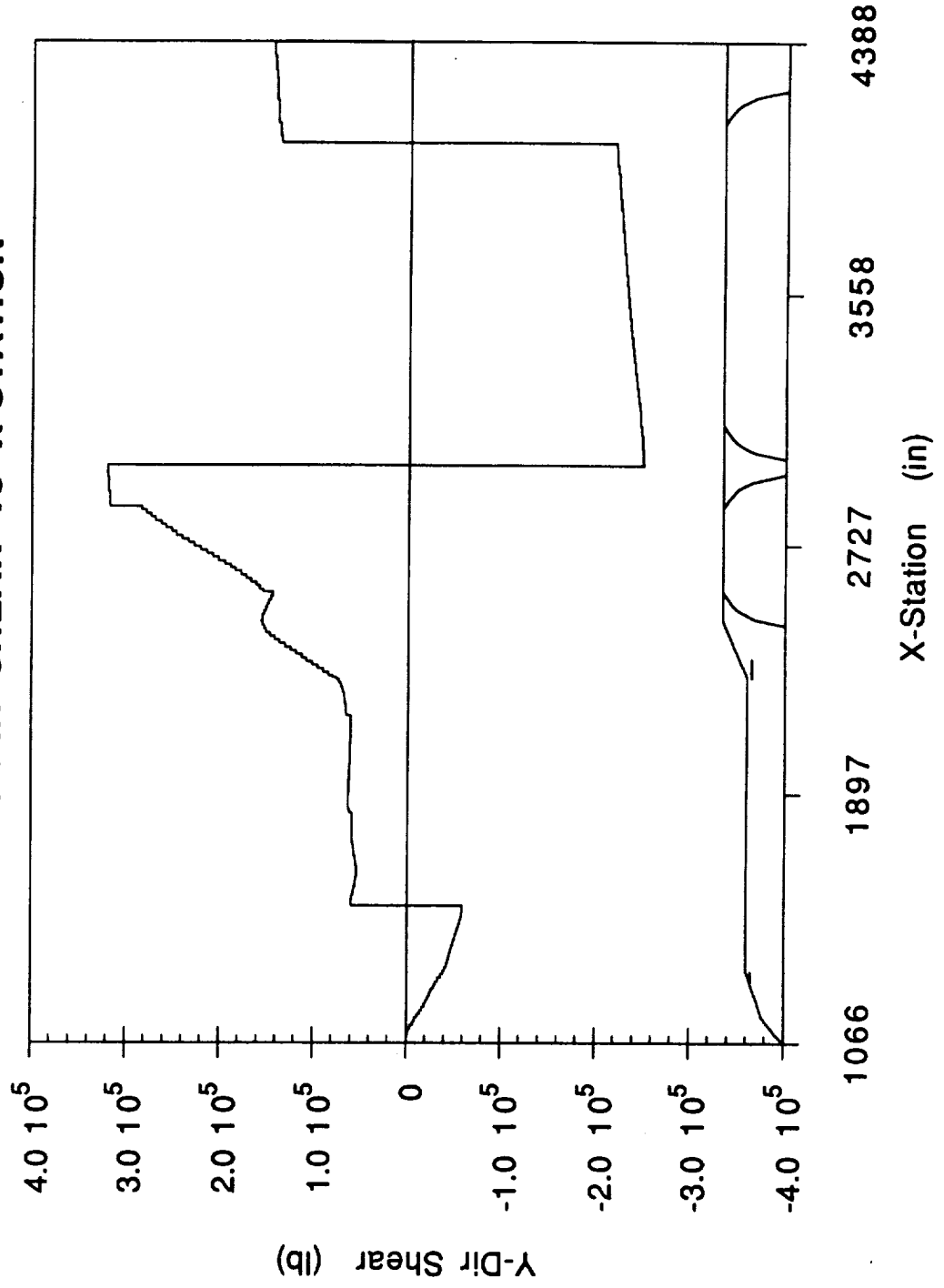

((

NLS1 CORE - 4 km
Z-DIR SHEAR vs X-STATION

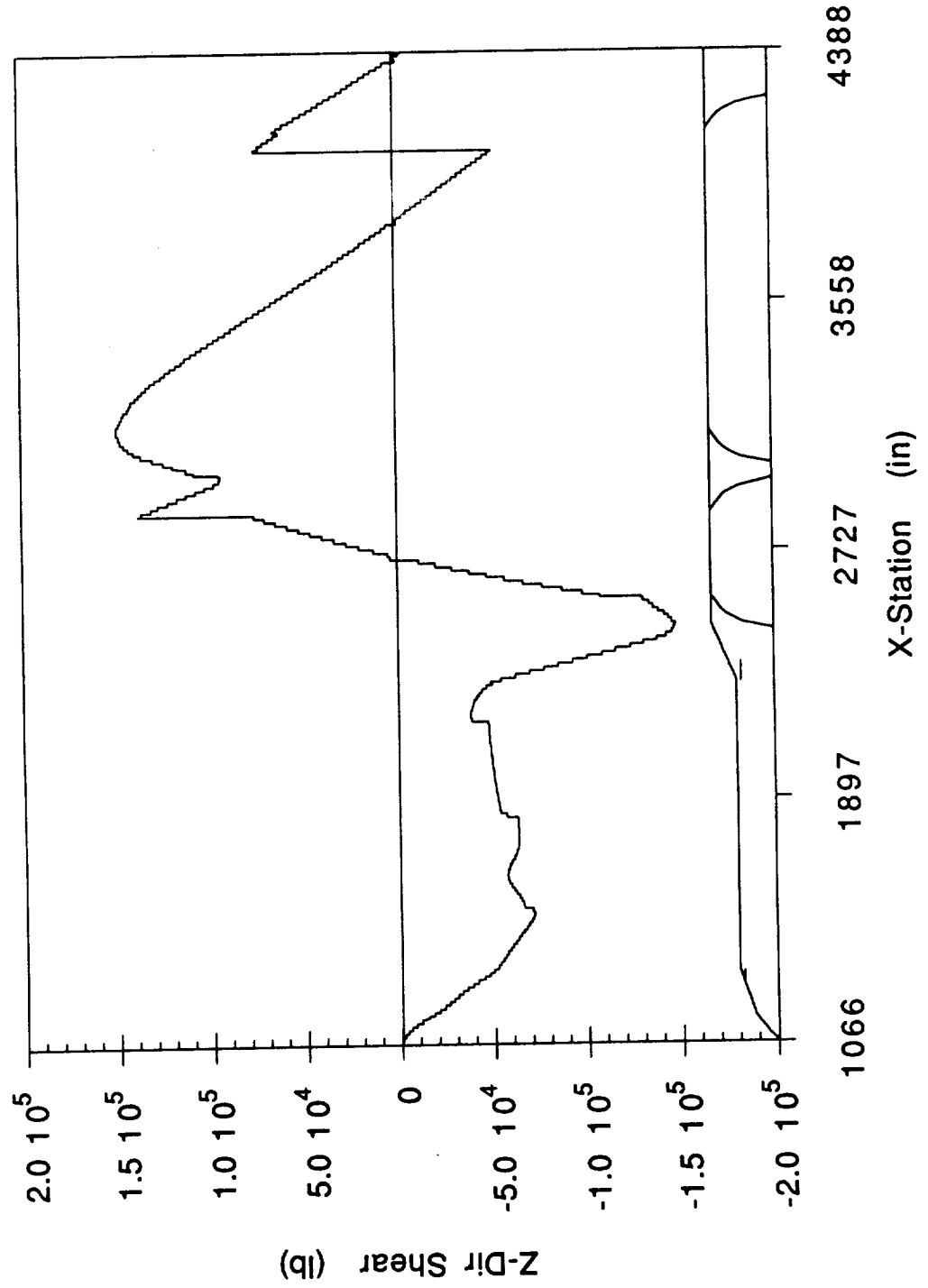

**NLS1 CORE - 4 km
Y-DIR MOMENT vs X-STATION**

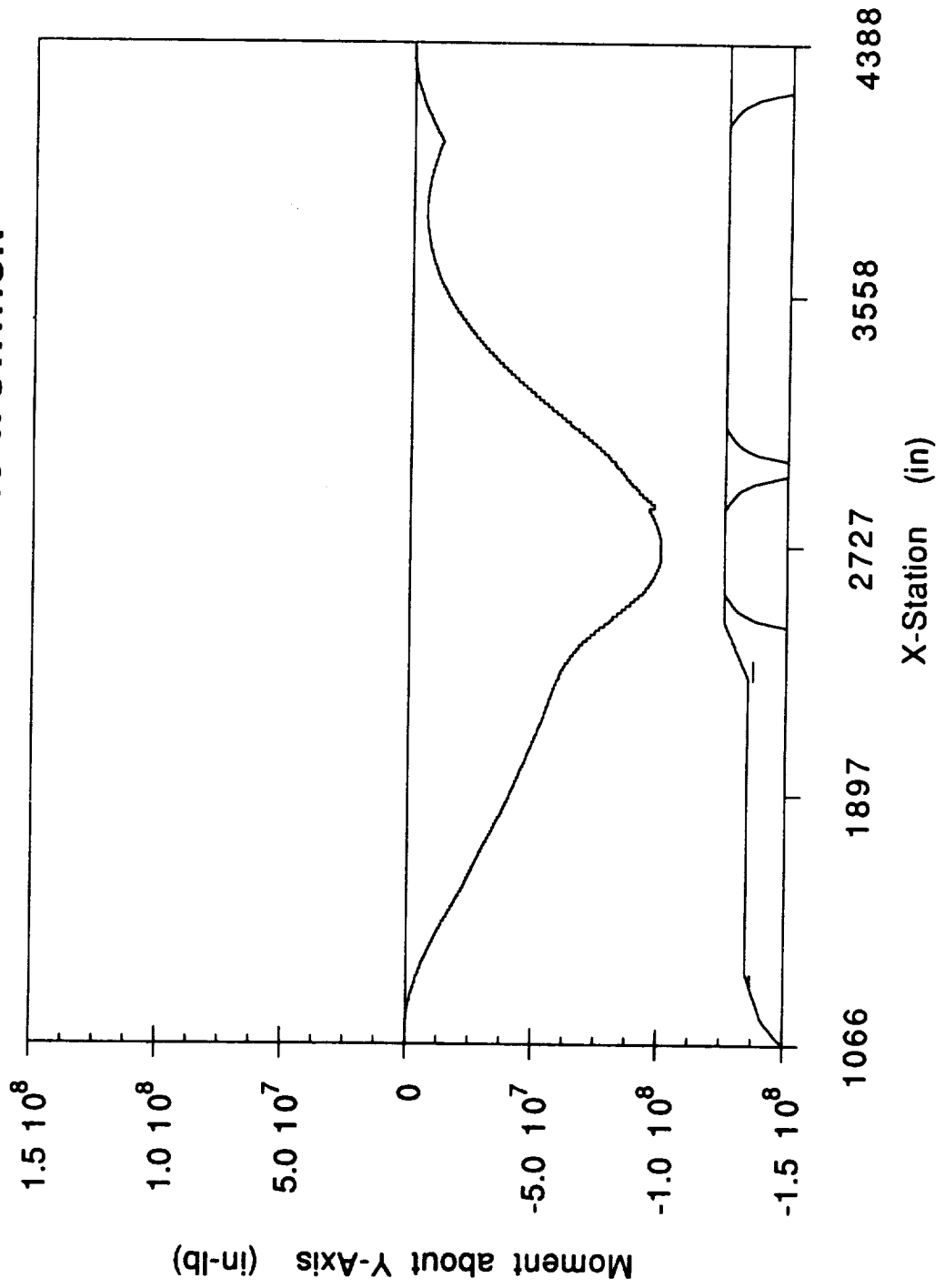

NLS1 CORE - 4 km
Z-DIR MOMENT vs X-STATION

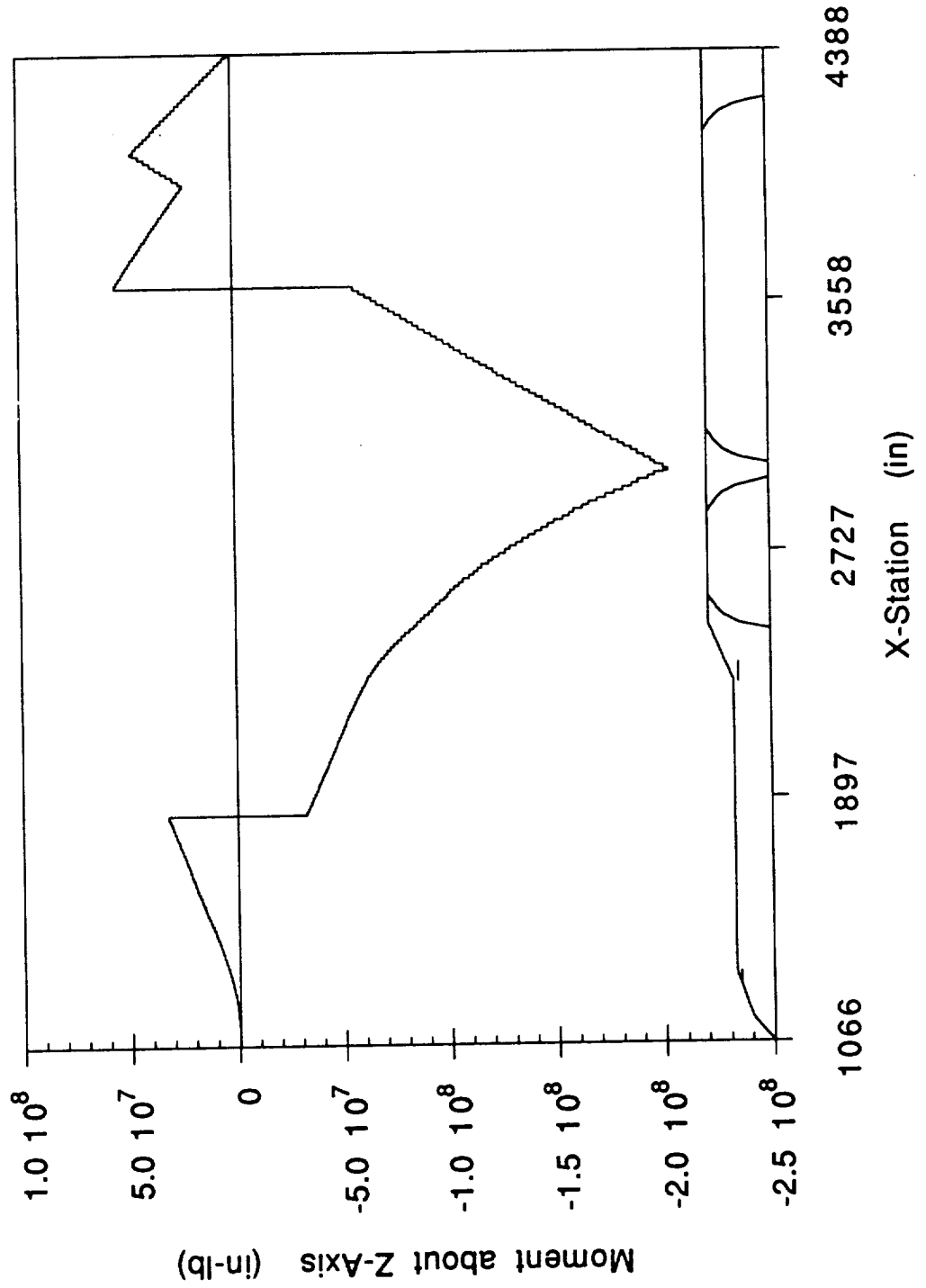

**NLS1 CORE - 5 km
NX vs X-STATION**

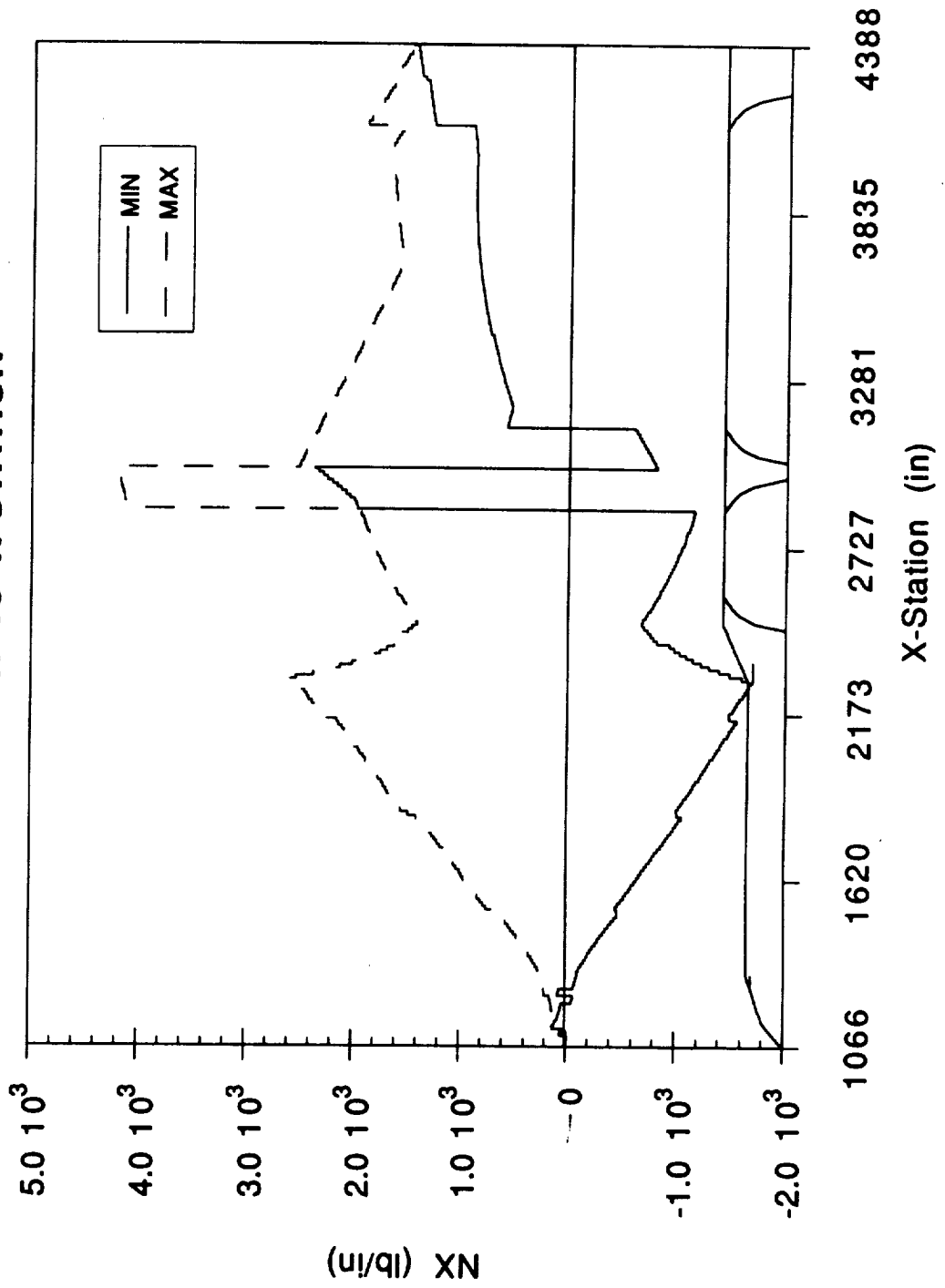

NLS1 CORE - 5 km
NV vs X-STATION

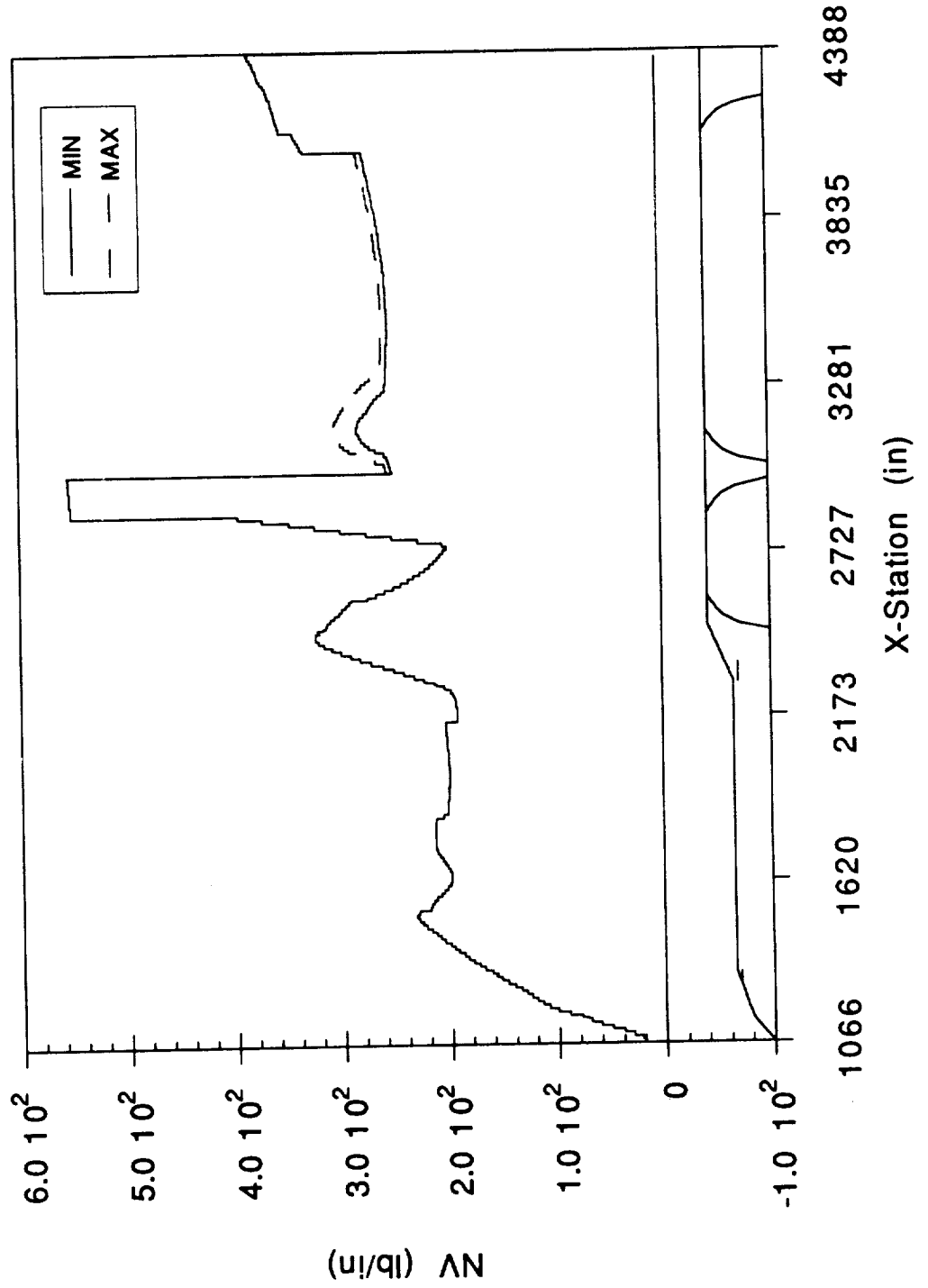

**NLS1 CORE - 5 km
AXIAL SHEAR vs X-STATION**

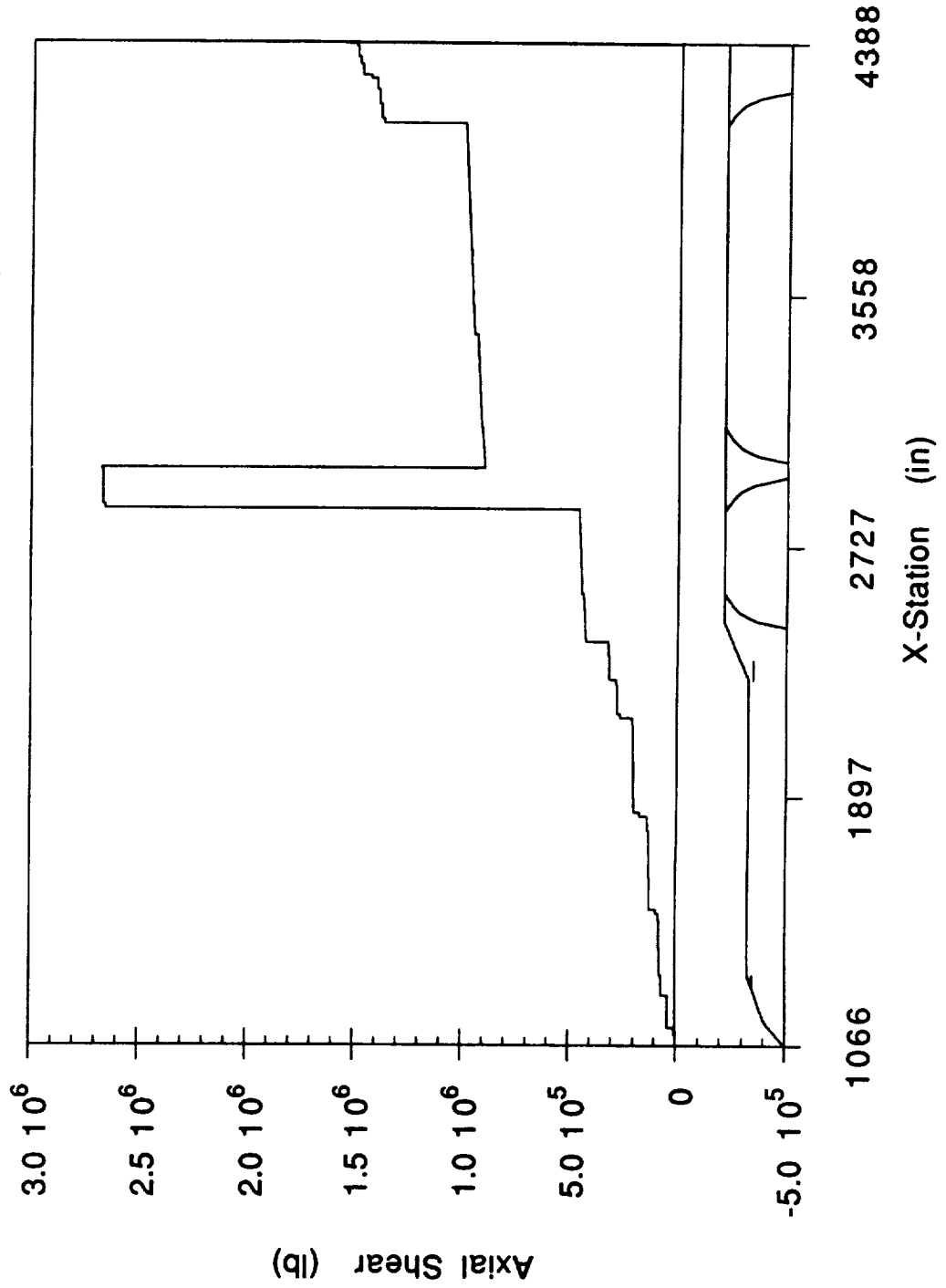

**NLS1 CORE - 5 km
Y-DIR SHEAR VS X-STATION**

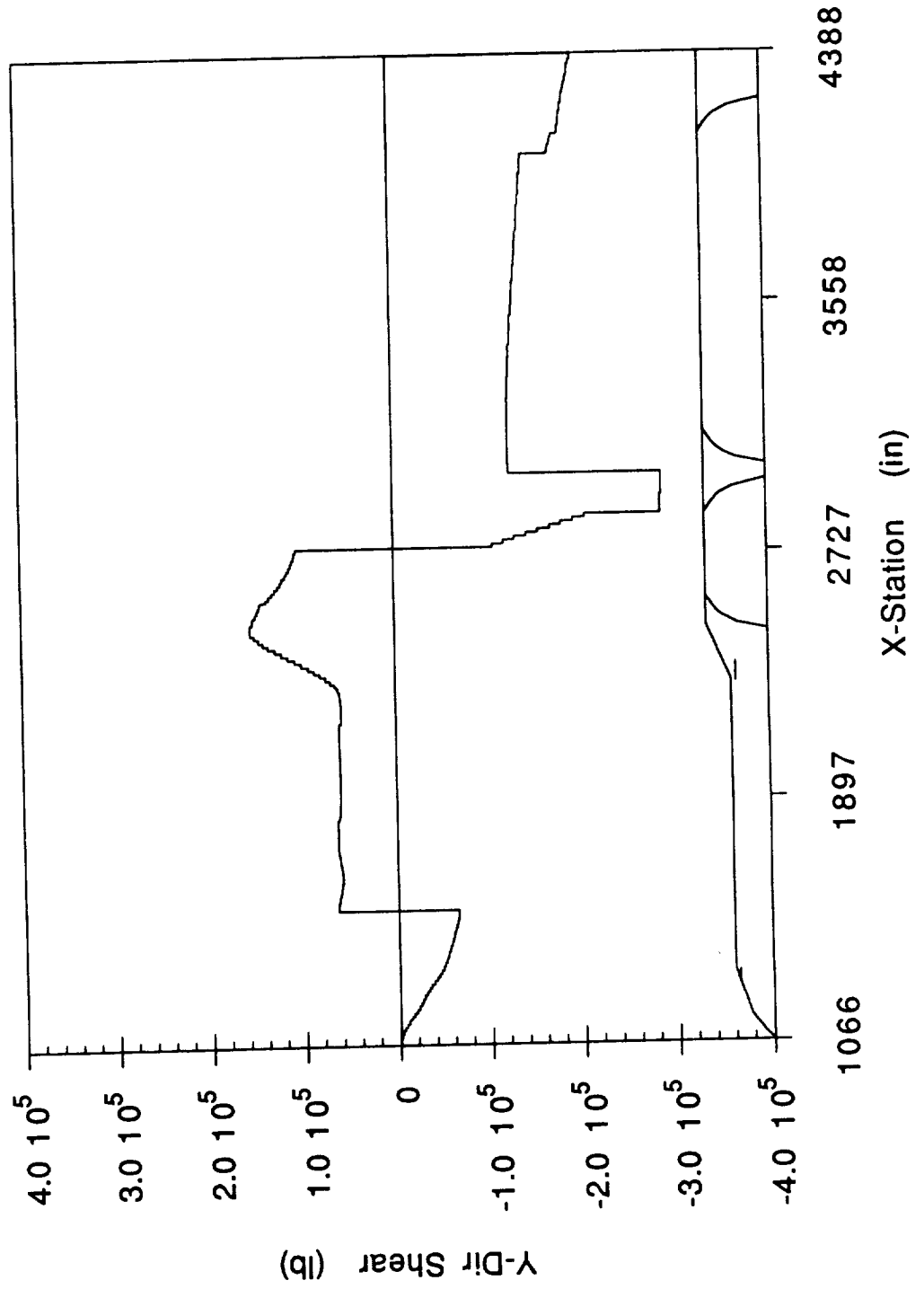

**NLS1 CORE - 5 km
Z-DIR SHEAR vs X-STATION**

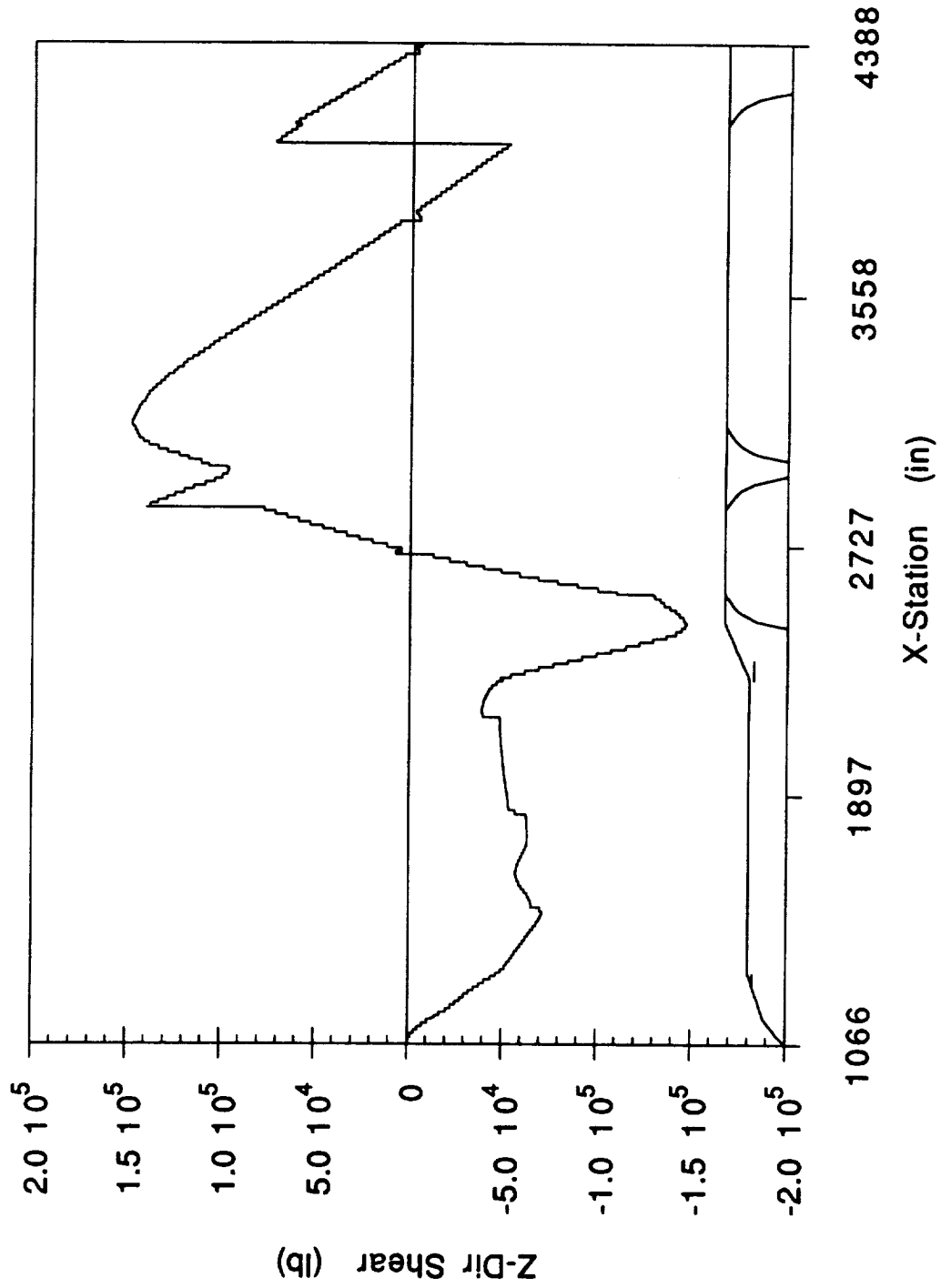

(((

**NLS1 CORE - 5 km
Y-DIR MOMENT vs X-STATION**

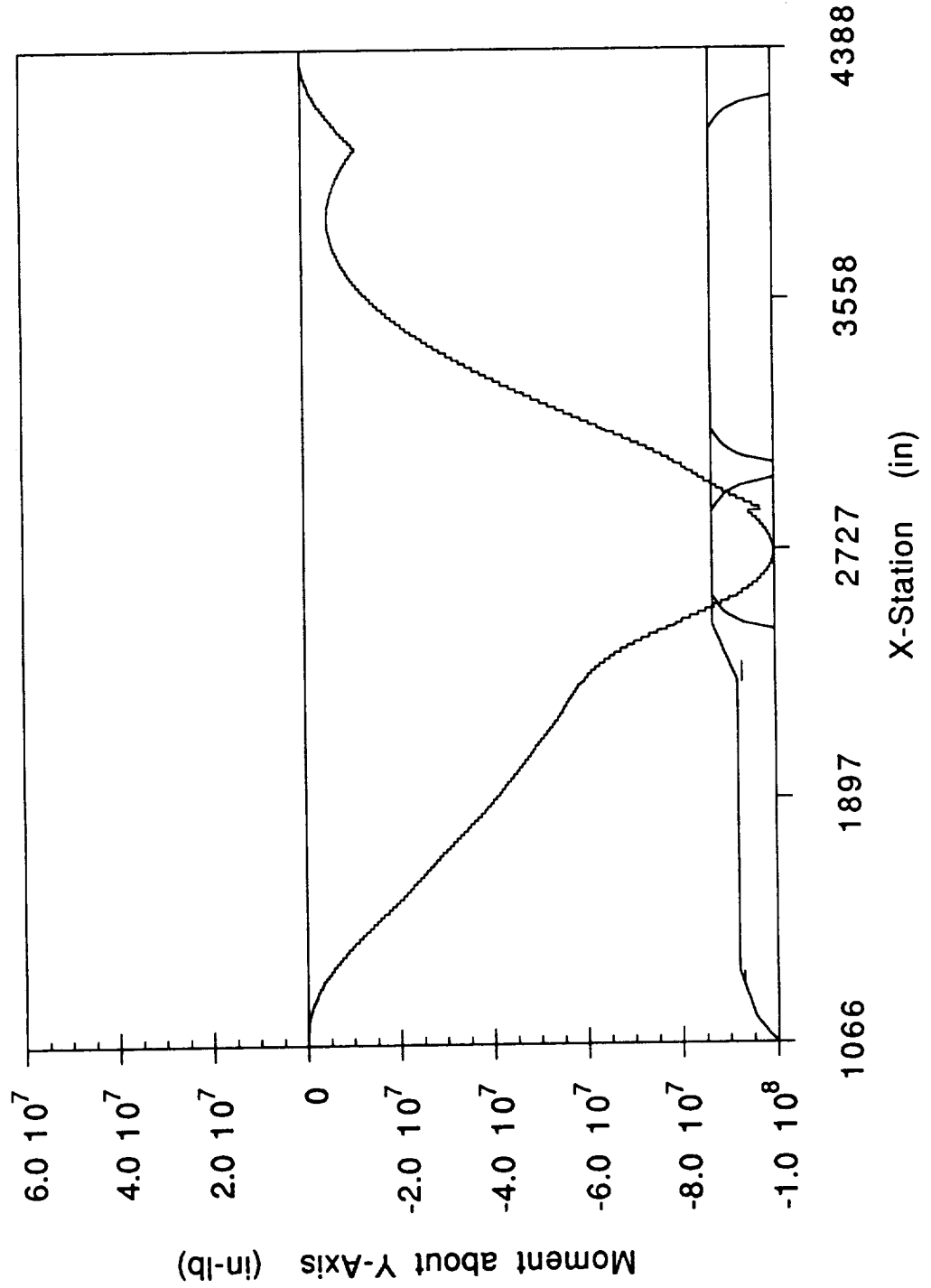

NLS1 CORE - 5 km Z-DIR MOMENT vs X-STATION

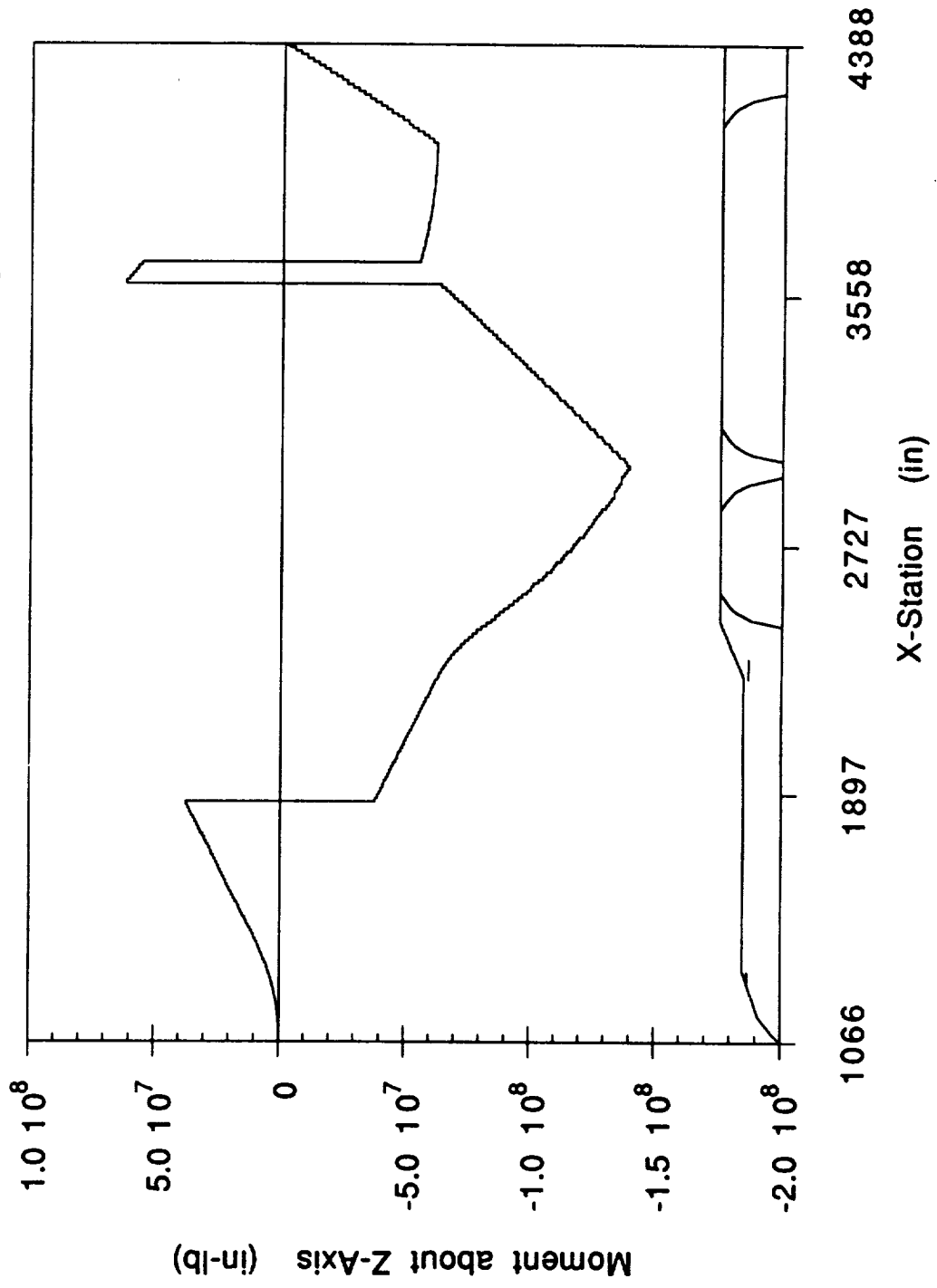

((

**NLS1 CORE - 6 km
NX vs X-STATION**

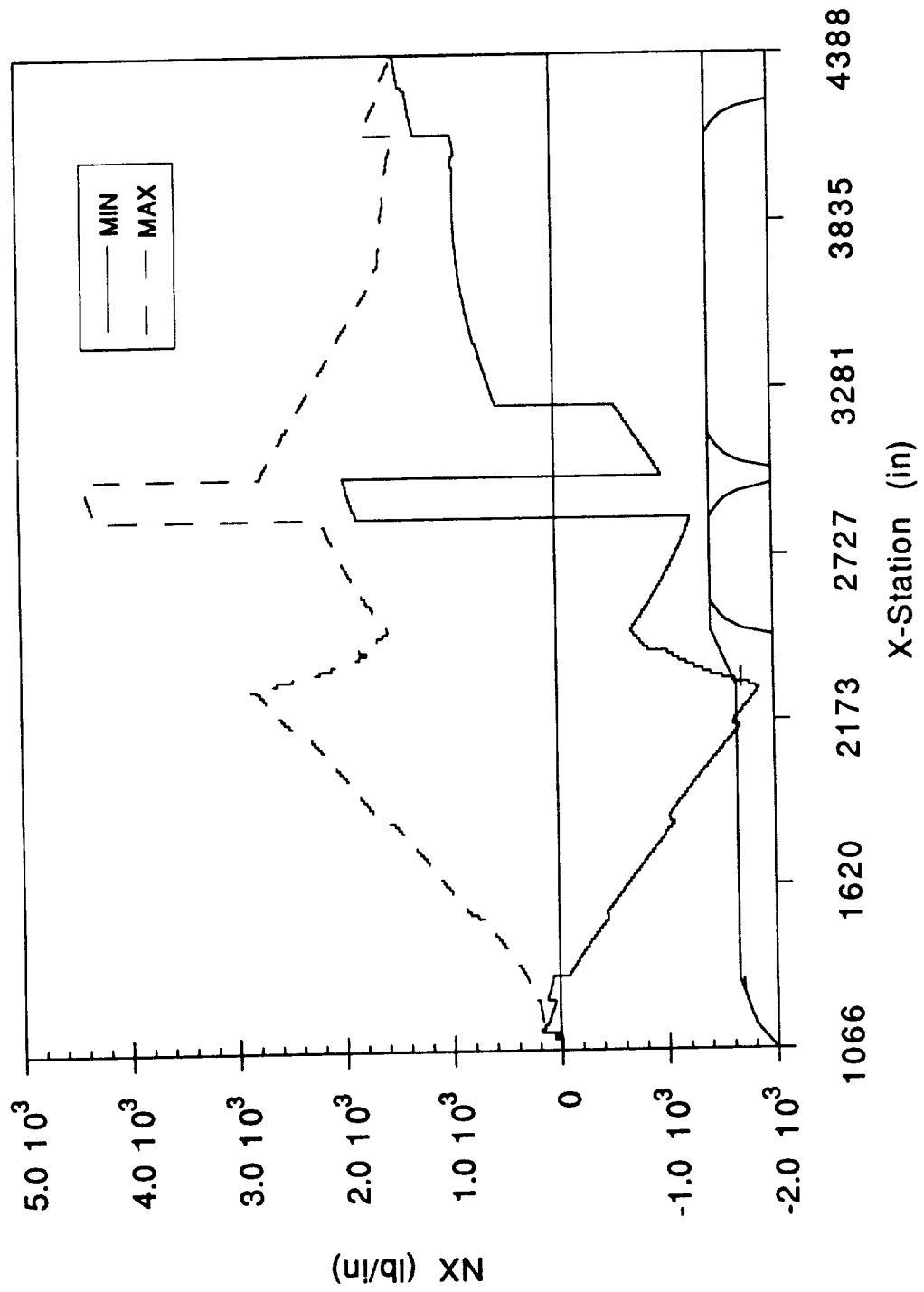

NLS1 CORE - 6 km NV vs X-STATION

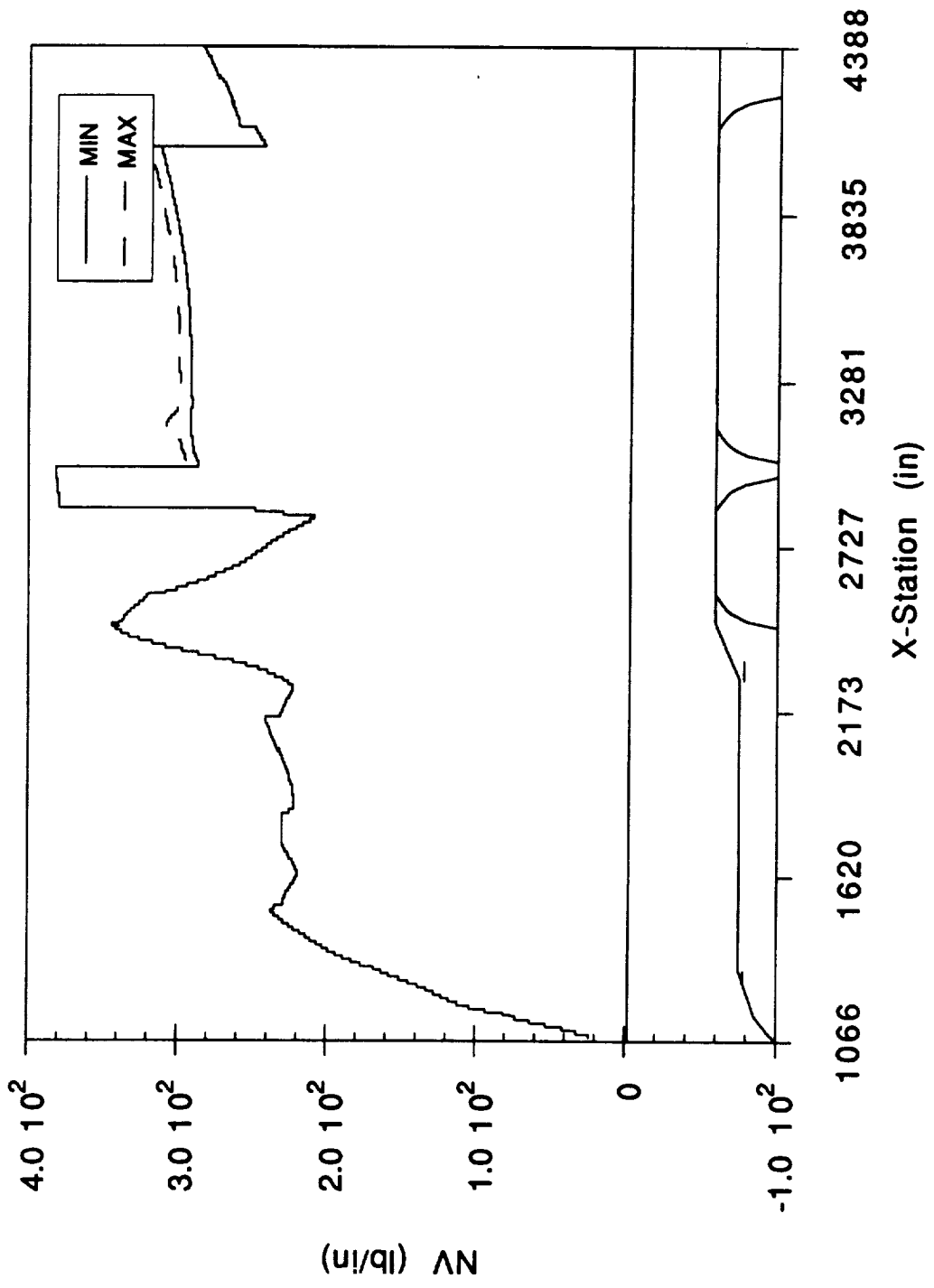

((

NLS1 CORE - 6 km
AXIAL SHEAR vs X-STATION

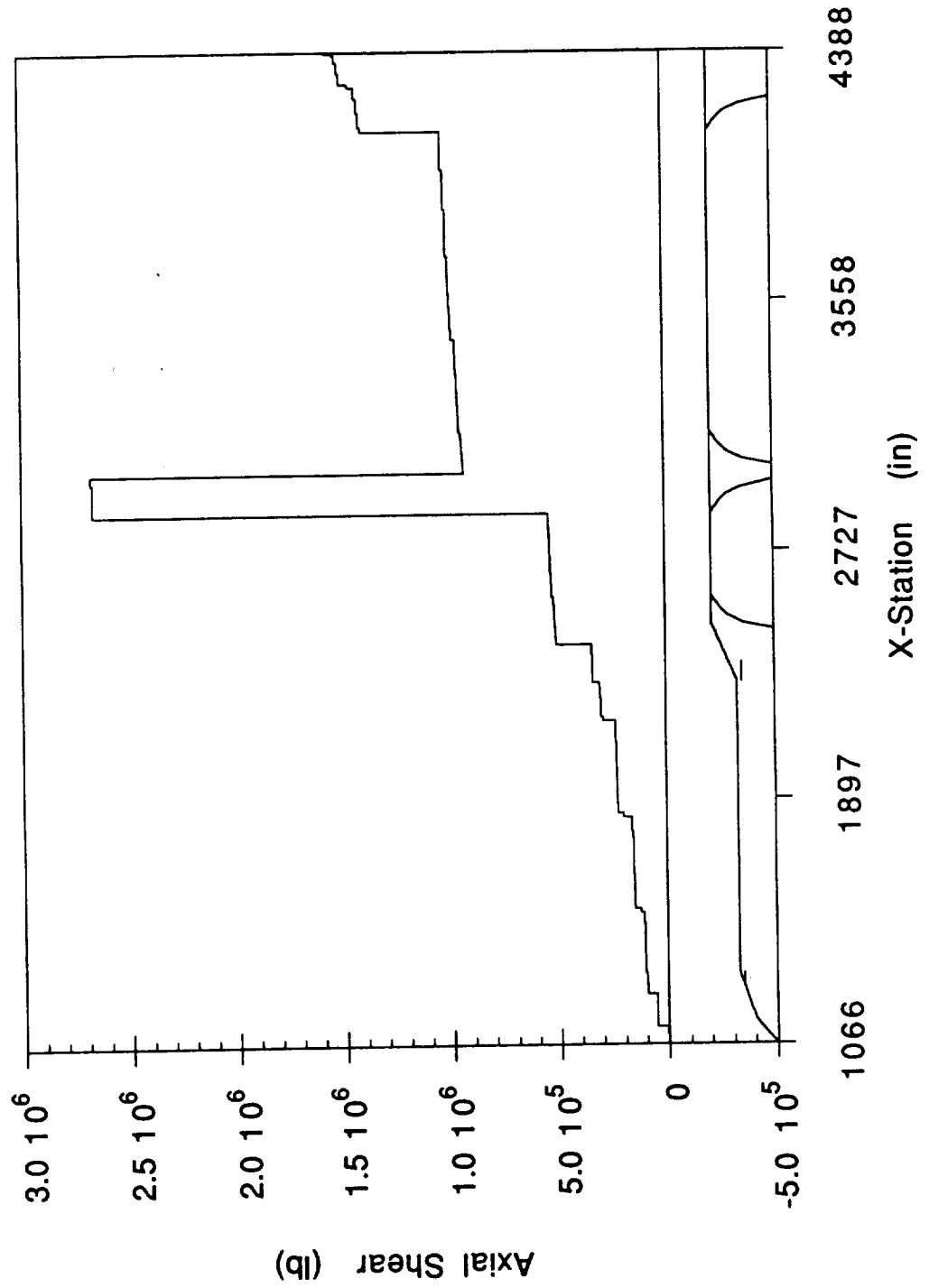

NLS1 CORE - 6 km Y-DIR SHEAR vs X-STATION

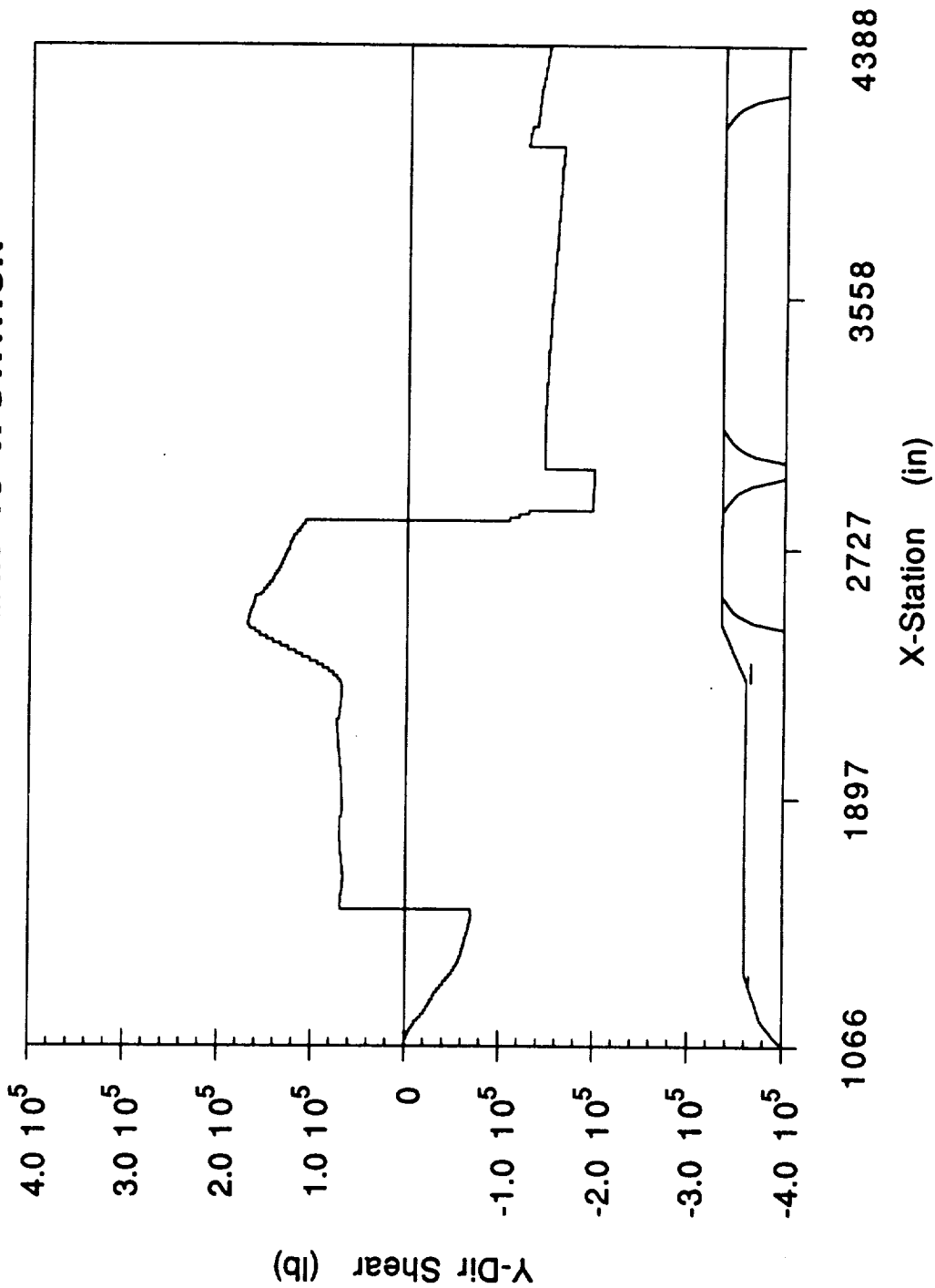

(

(

(

**NLS1 CORE - 6 km
Z-DIR SHEAR vs X-STATION**

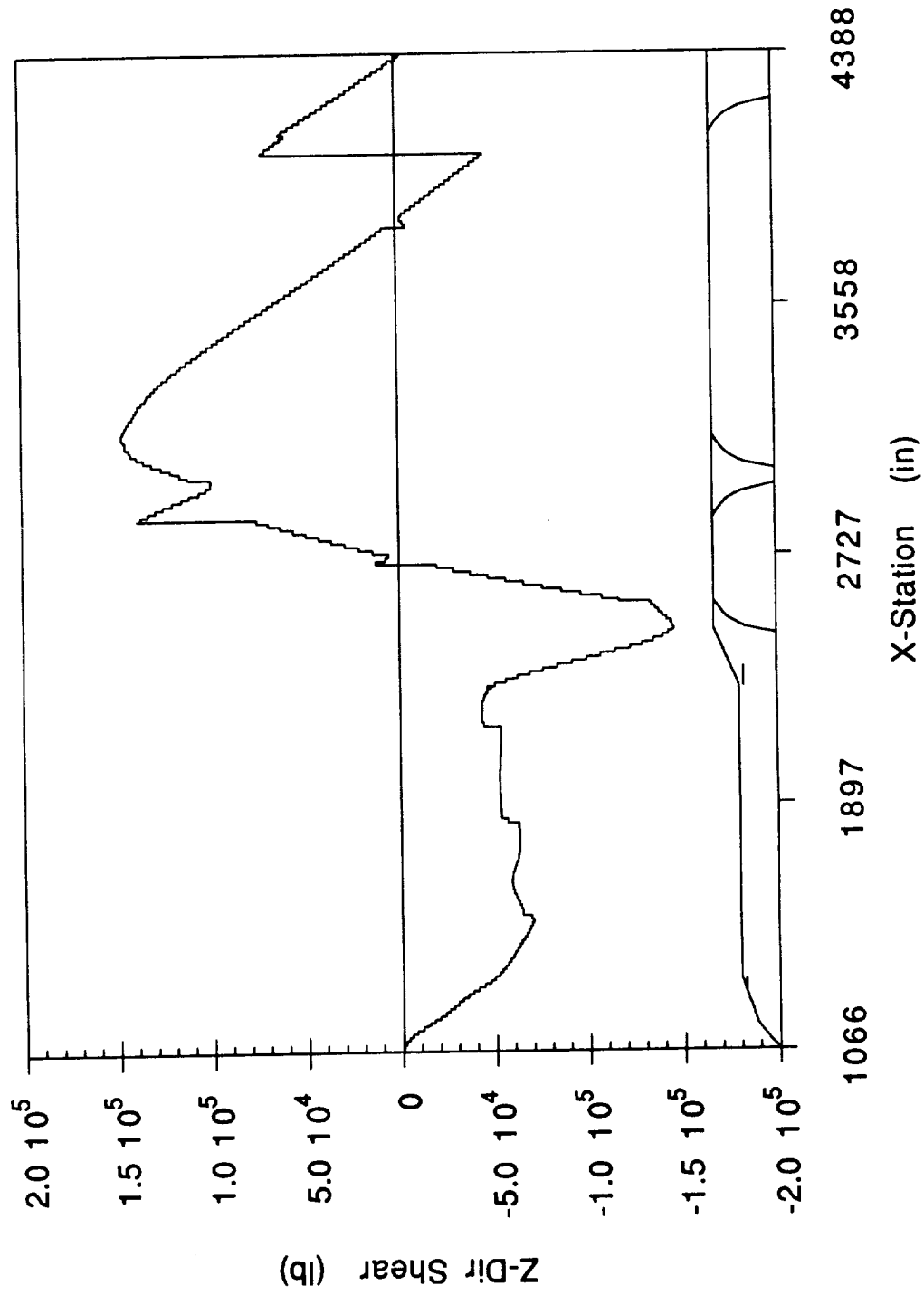

NLS1 CORE - 6 km Y-DIR MOMENT vs X-STATION

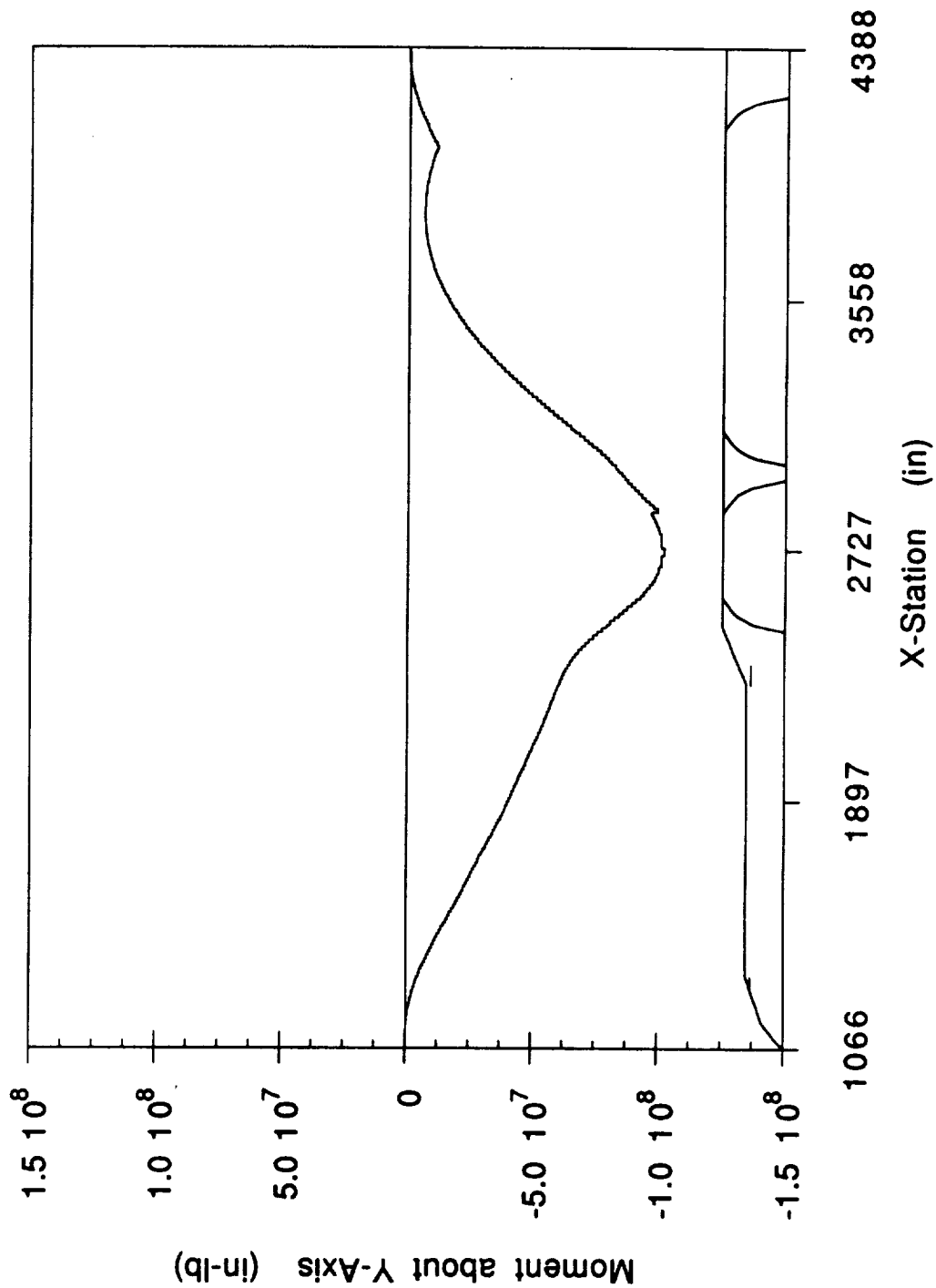

(

(

(

NLS1 CORE - 6 km
Z-DIR MOMENT vs X-STATION

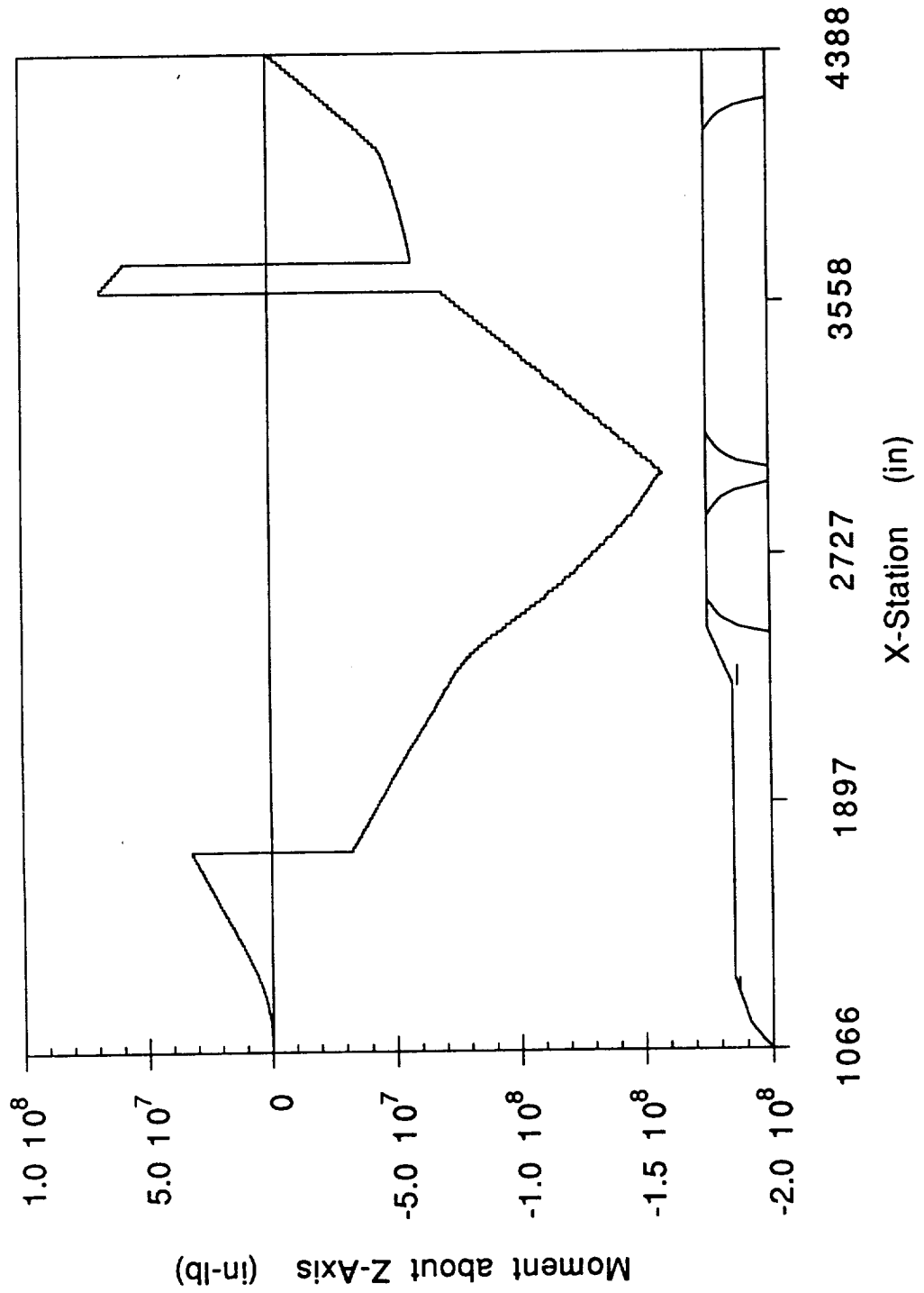

NLS1 CORE - 8 km NX vs X-STATION

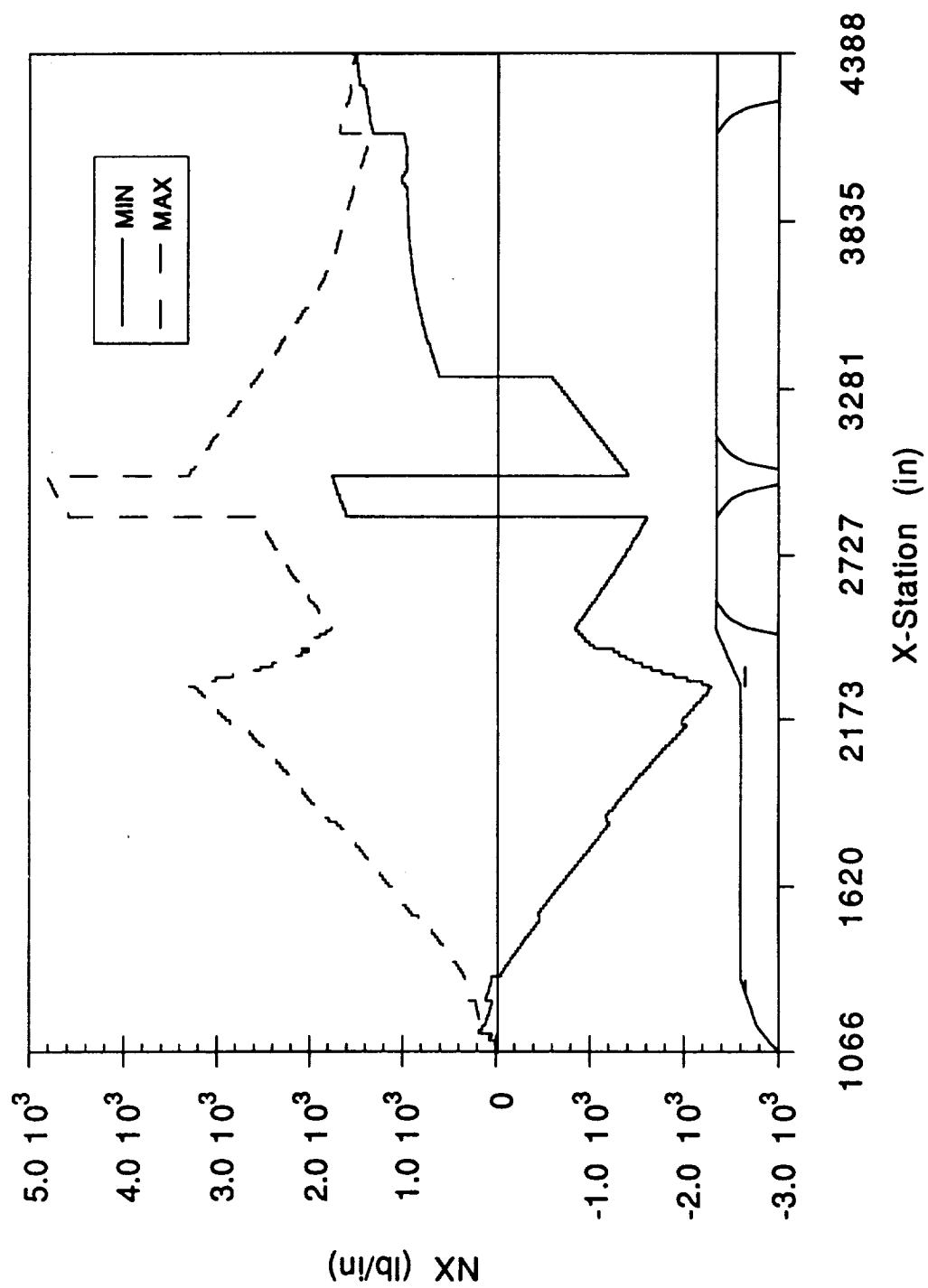

(((

**NLS1 CORE - 8 km
NV vs X-STATION**

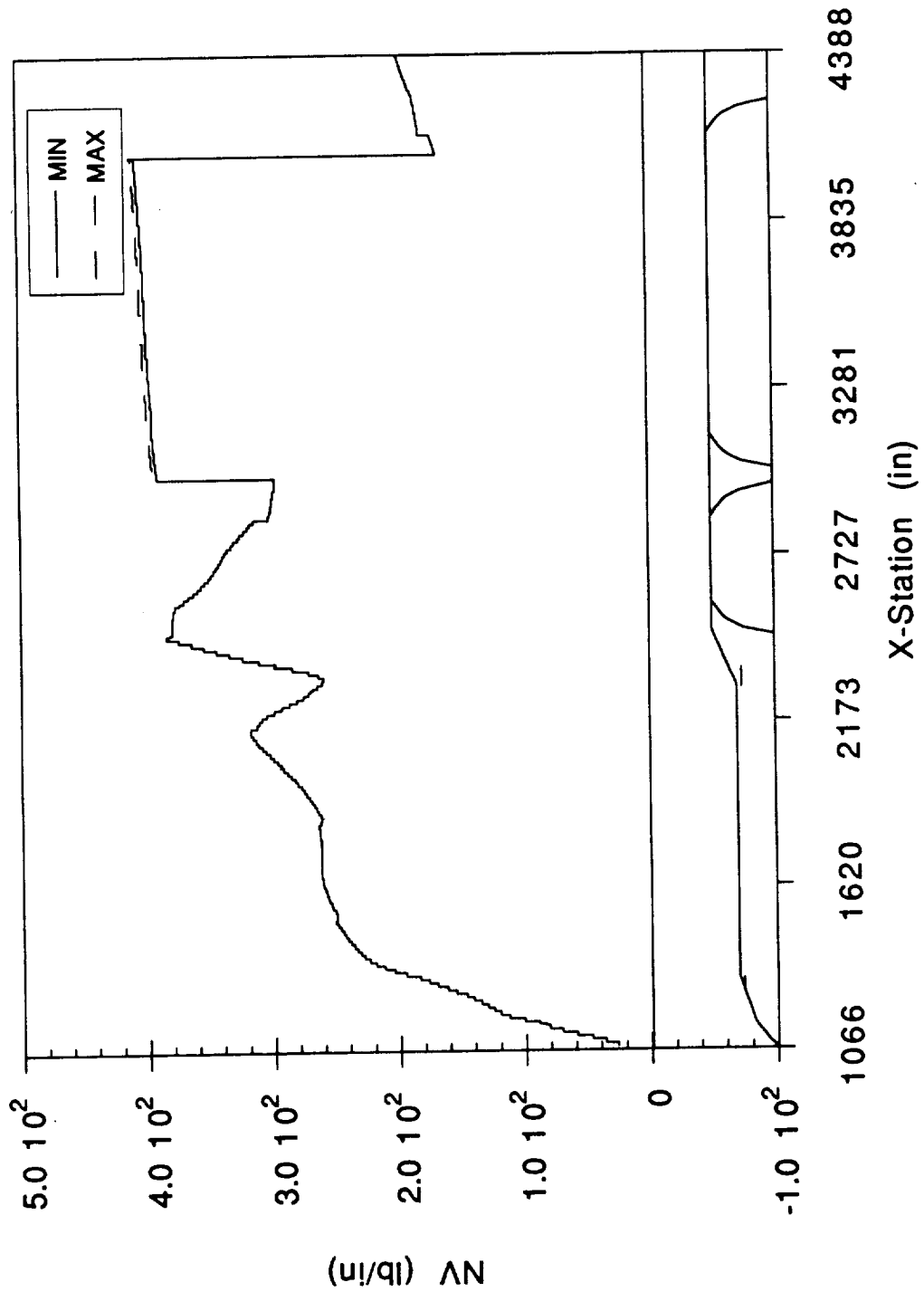

NLS1 CORE - 8 km AXIAL SHEAR VS X-STATION

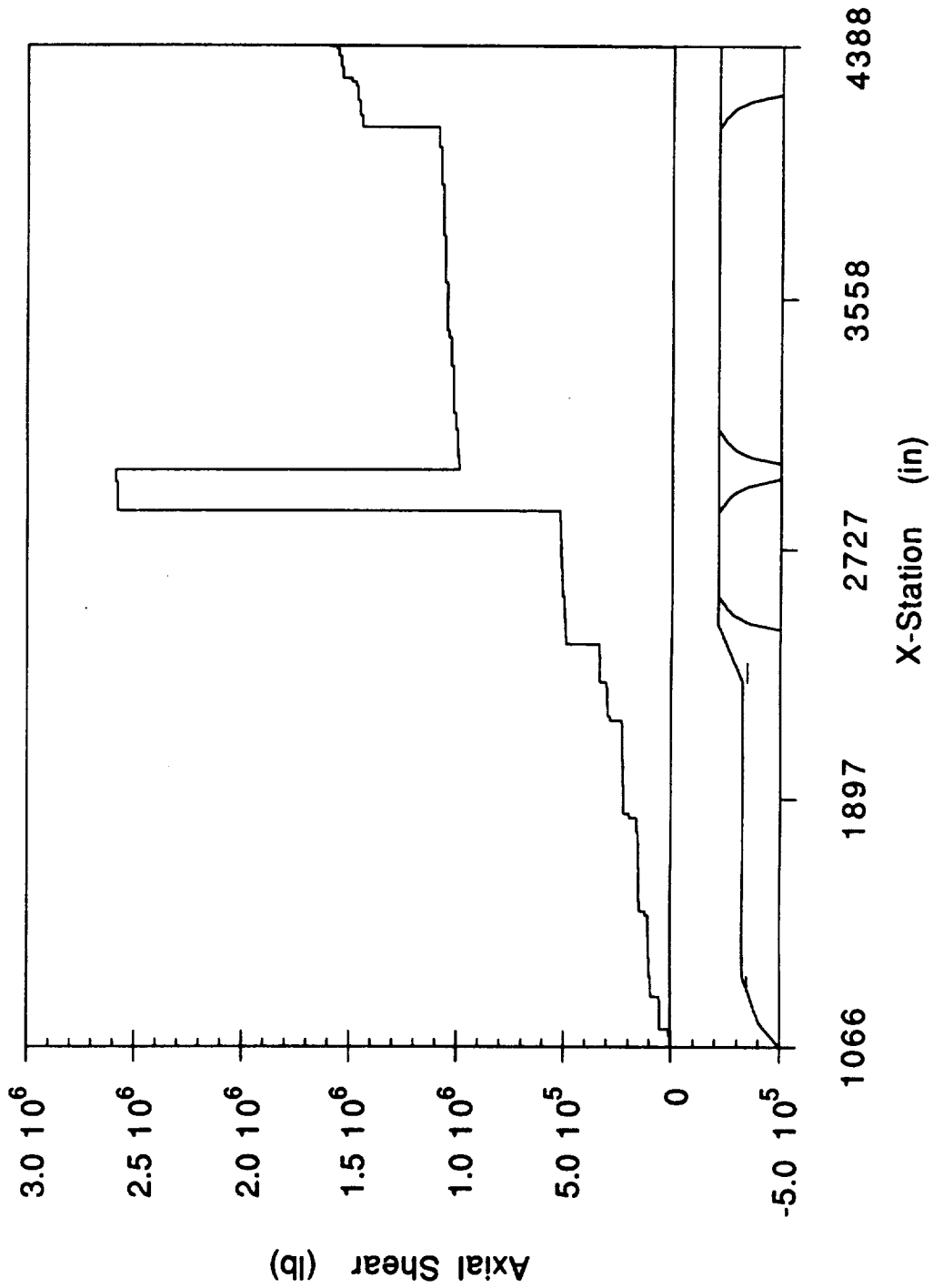

(((

**NLS1 CORE - 8 km
Y-DIR SHEAR vs X-STATION**

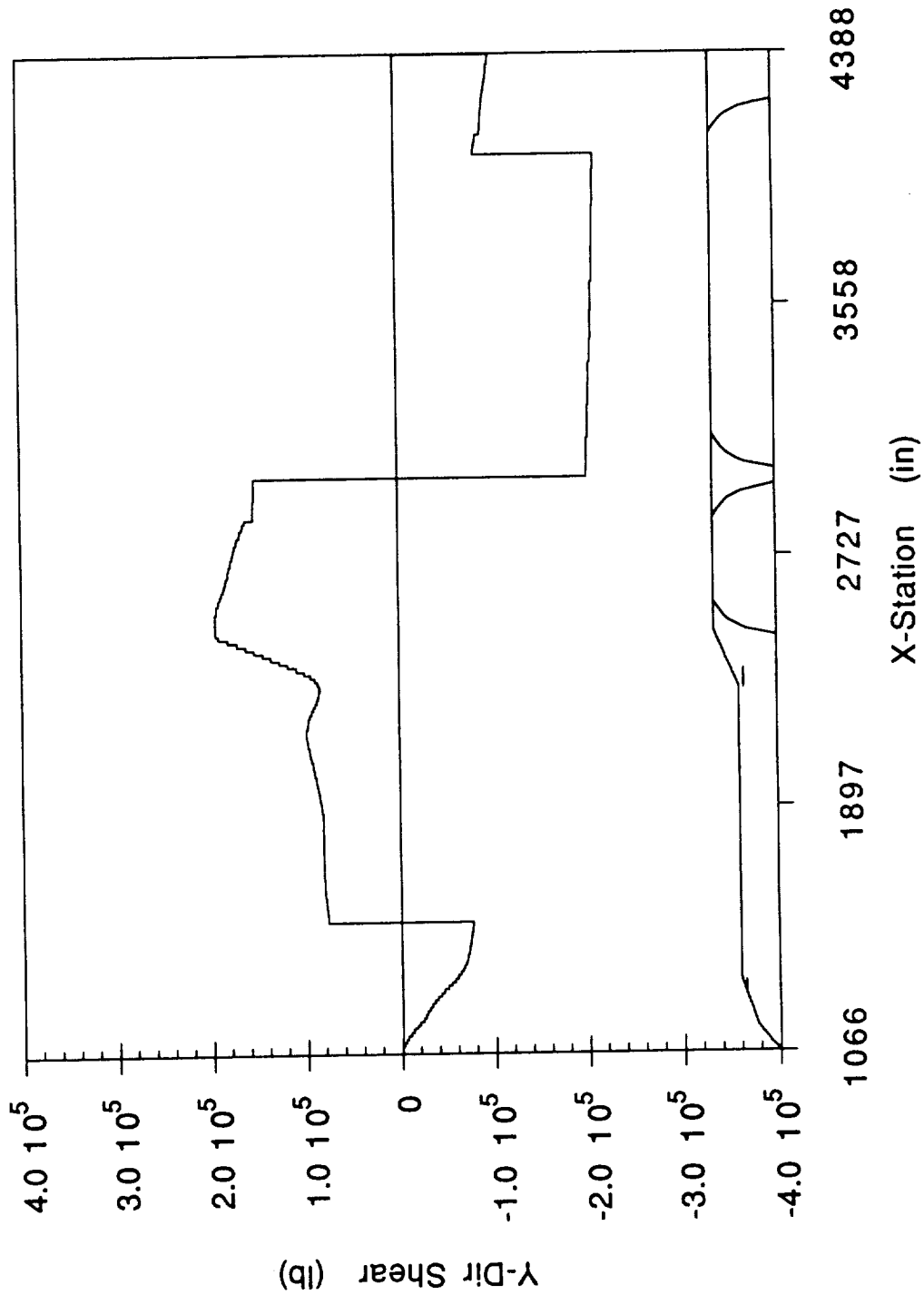

**NLS1 CORE - 8 km
Z-DIR SHEAR vs X-STATION**

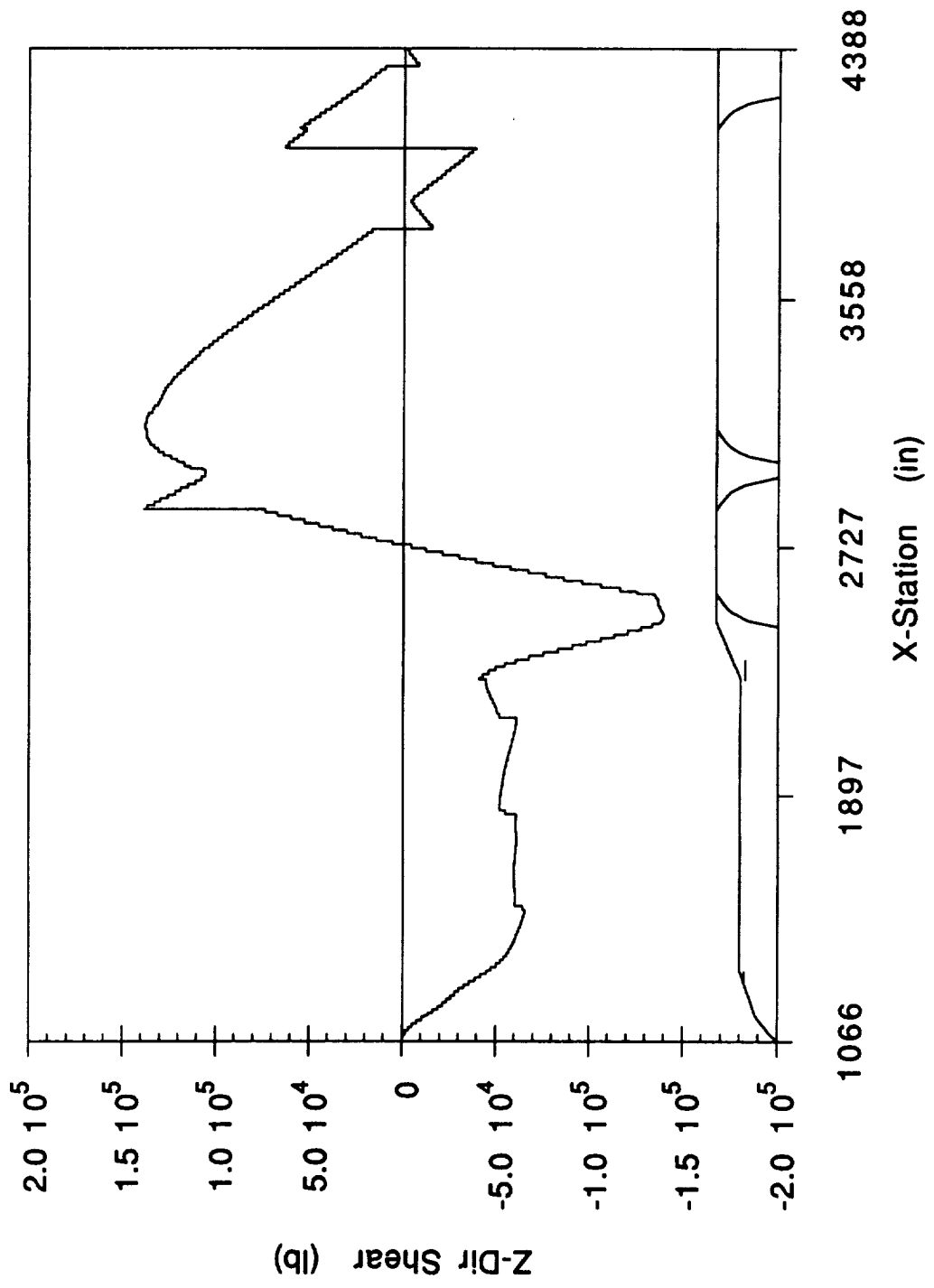

**NLS1 CORE - 8 km
Y-DIR MOMENT vs X-STATION**

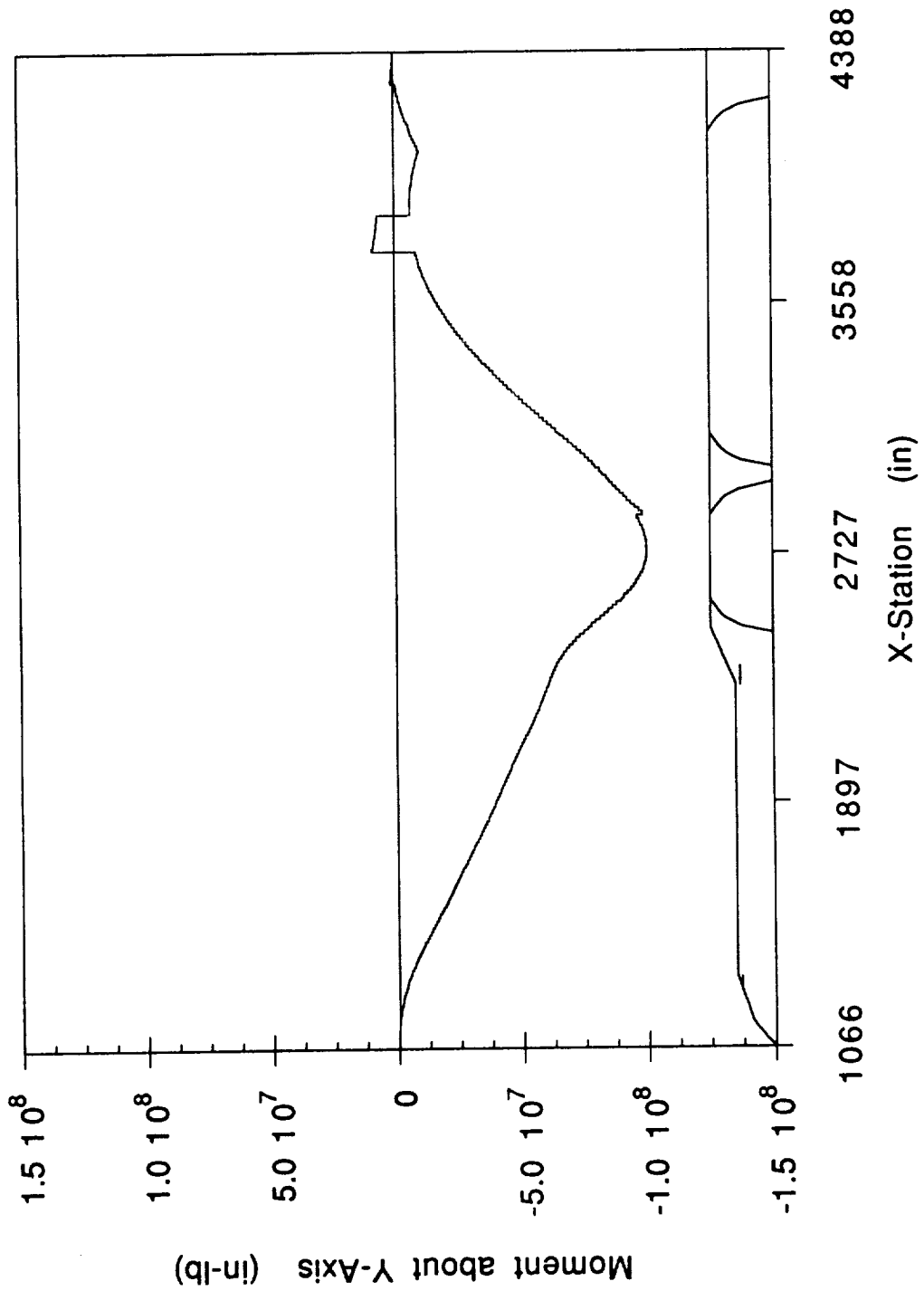

NLS1 CORE - 8 km Z-DIR MOMENT vs X-STATION

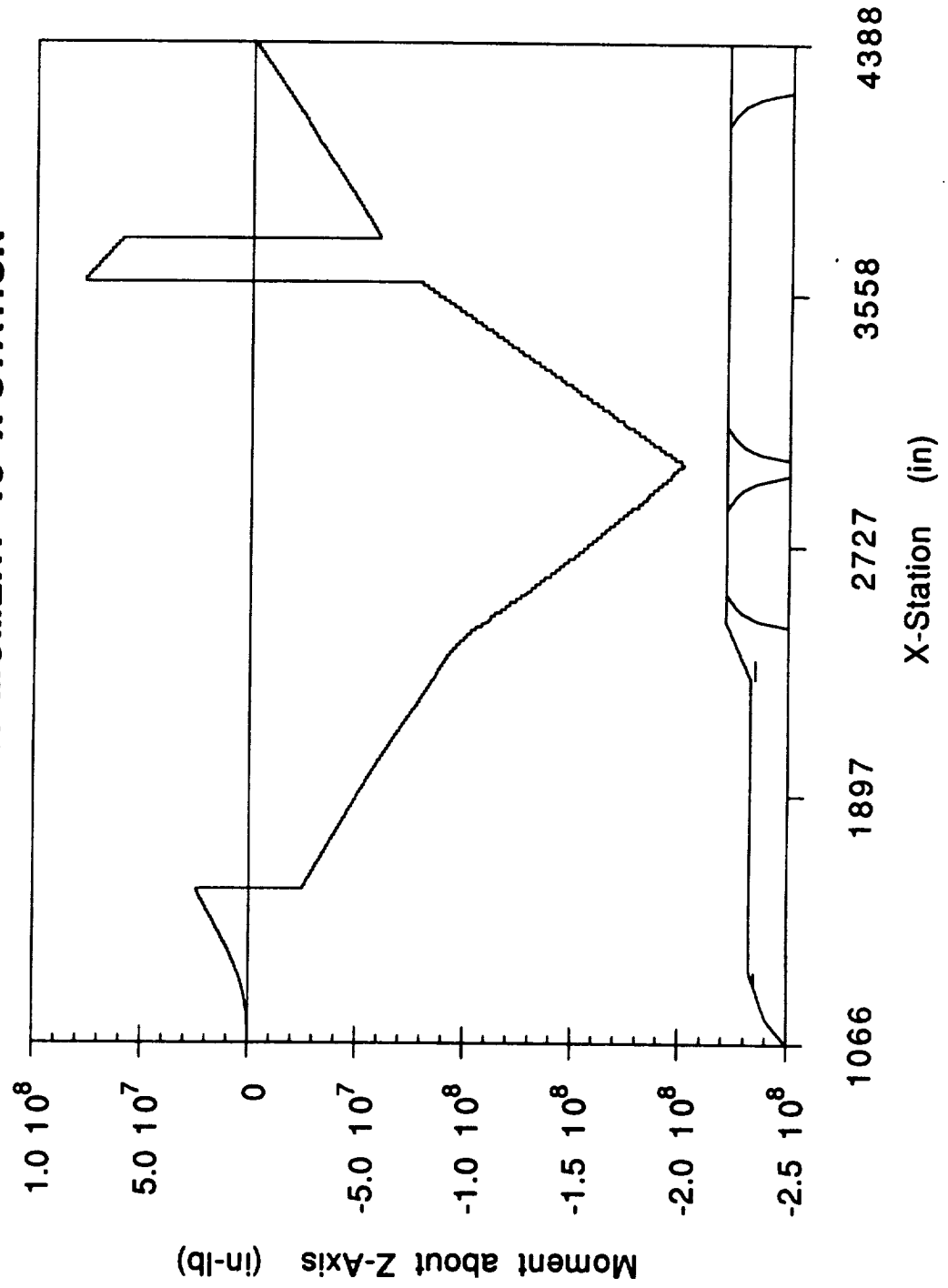

((

**NLS1 CORE - 10 km
NX vs X-STATION**

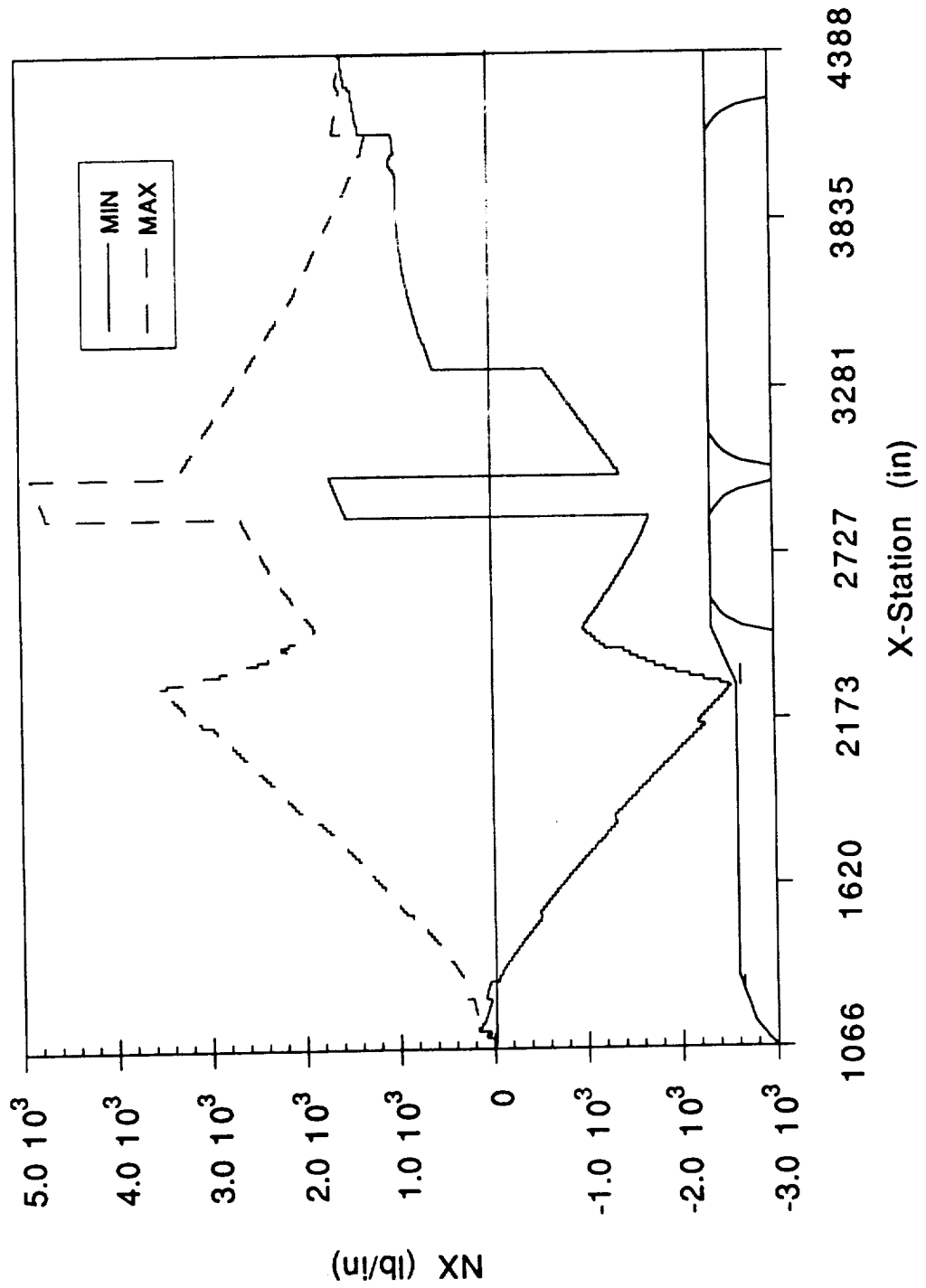

**NLS1 CORE - 10 km
NV vs X-STATION**

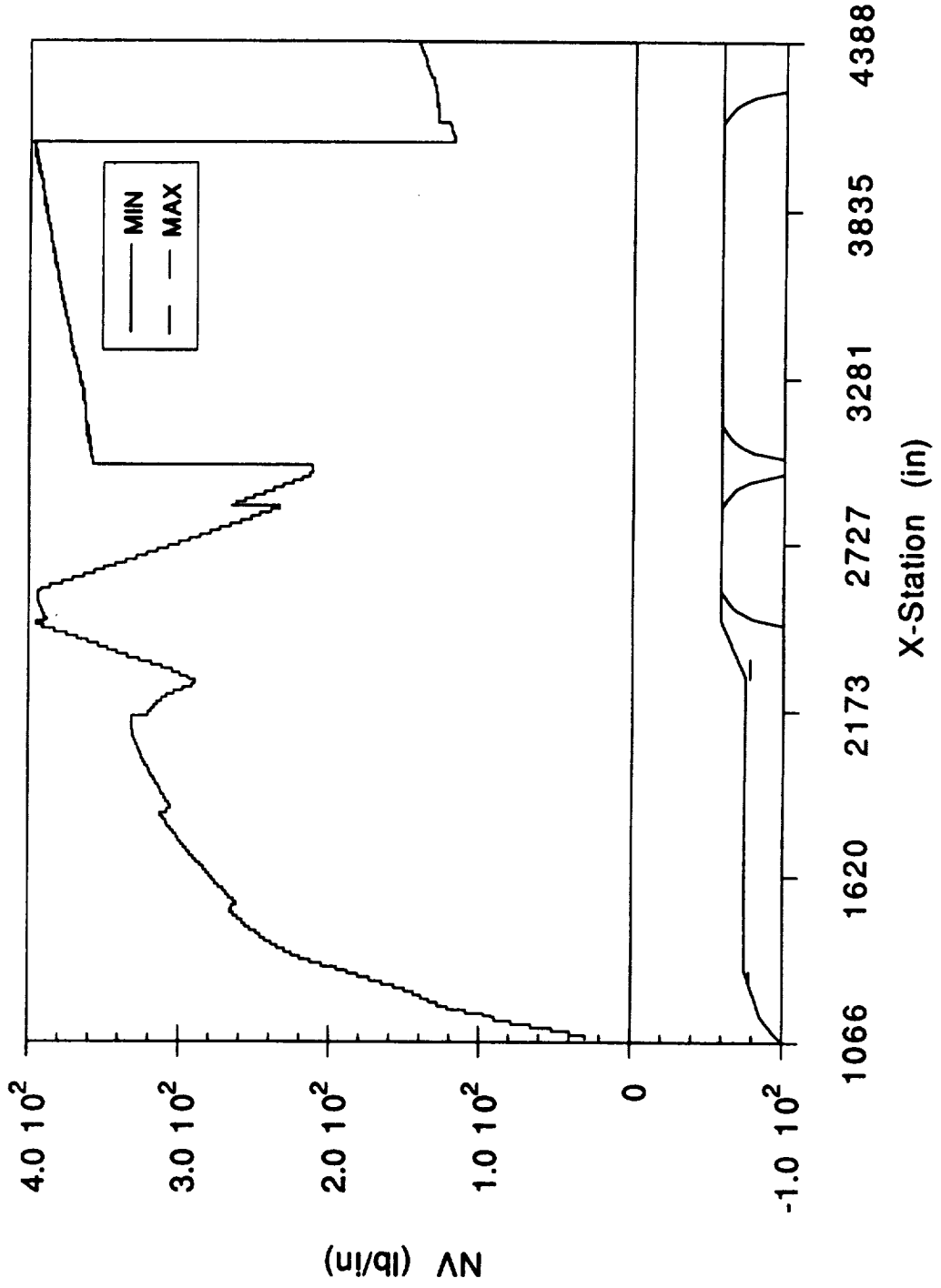

((

**NLS1 CORE - 10 km
AXIAL SHEAR VS X-STATION**

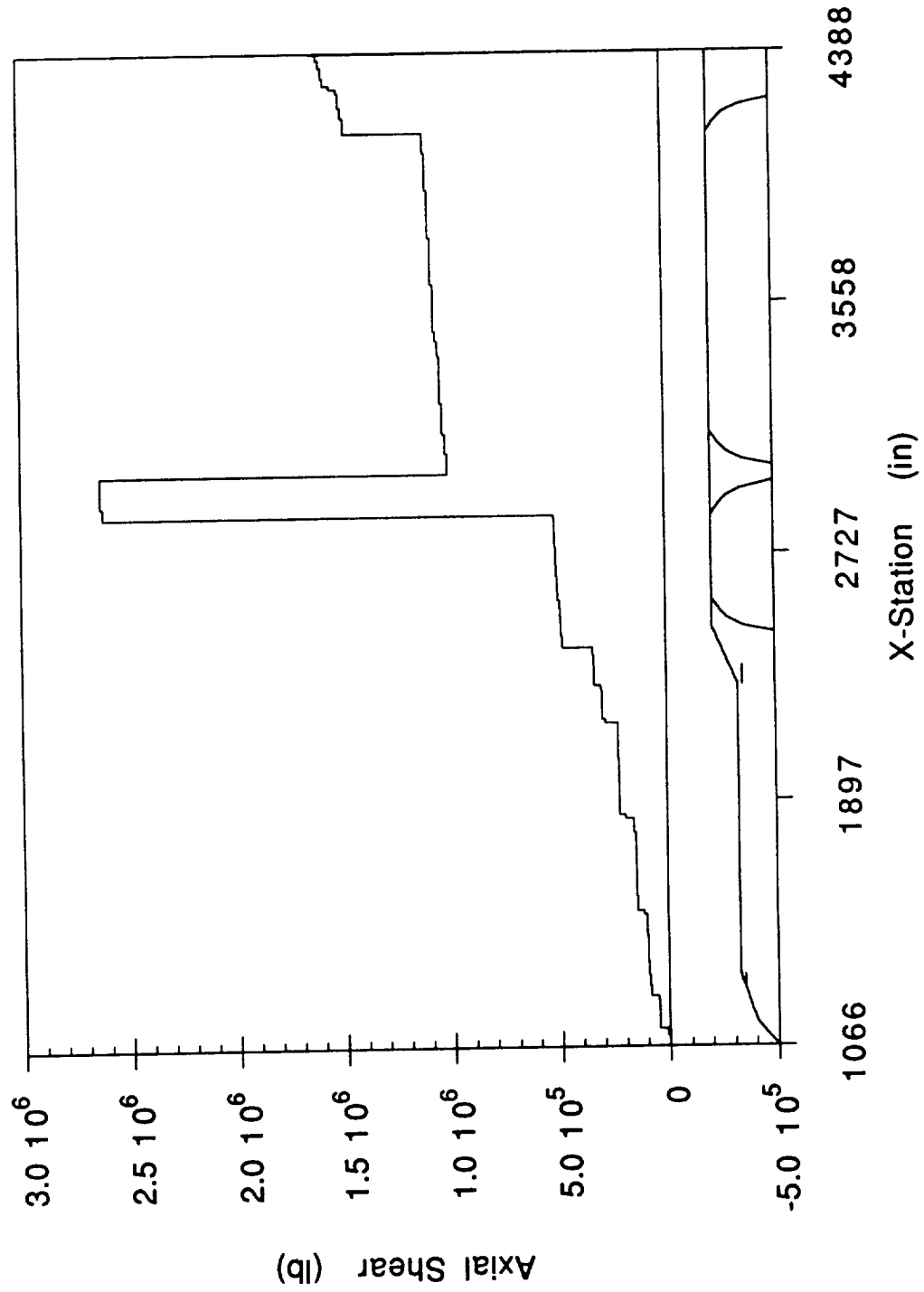

NLS1 CORE - 10 km Y-DIR SHEAR vs X-STATION

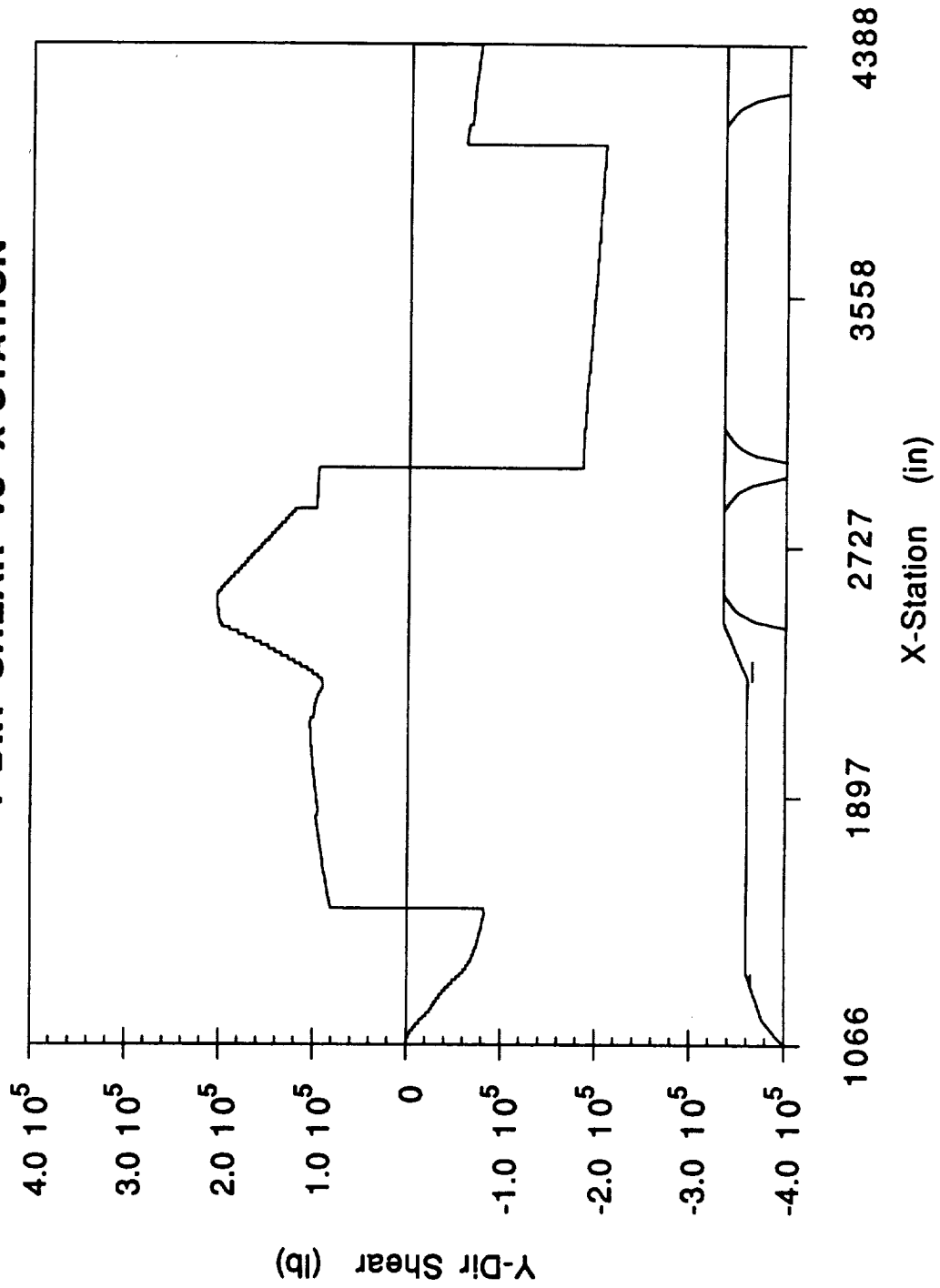

((

NLS1 CORE - 10 km
Z-DIR SHEAR vs X-STATION

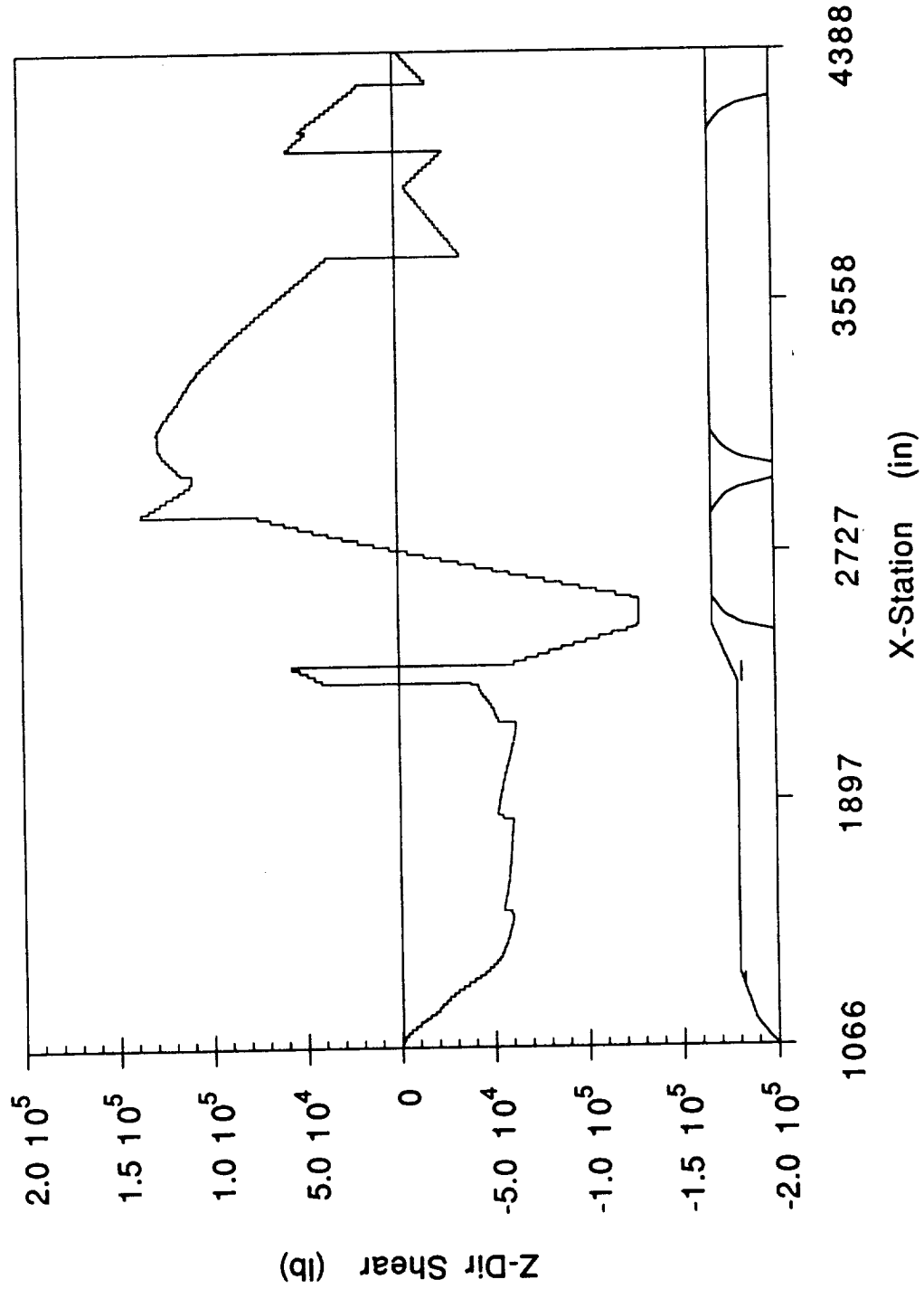

**NLS1 CORE - 10 km
Y-DIR MOMENT vs X-STATION**

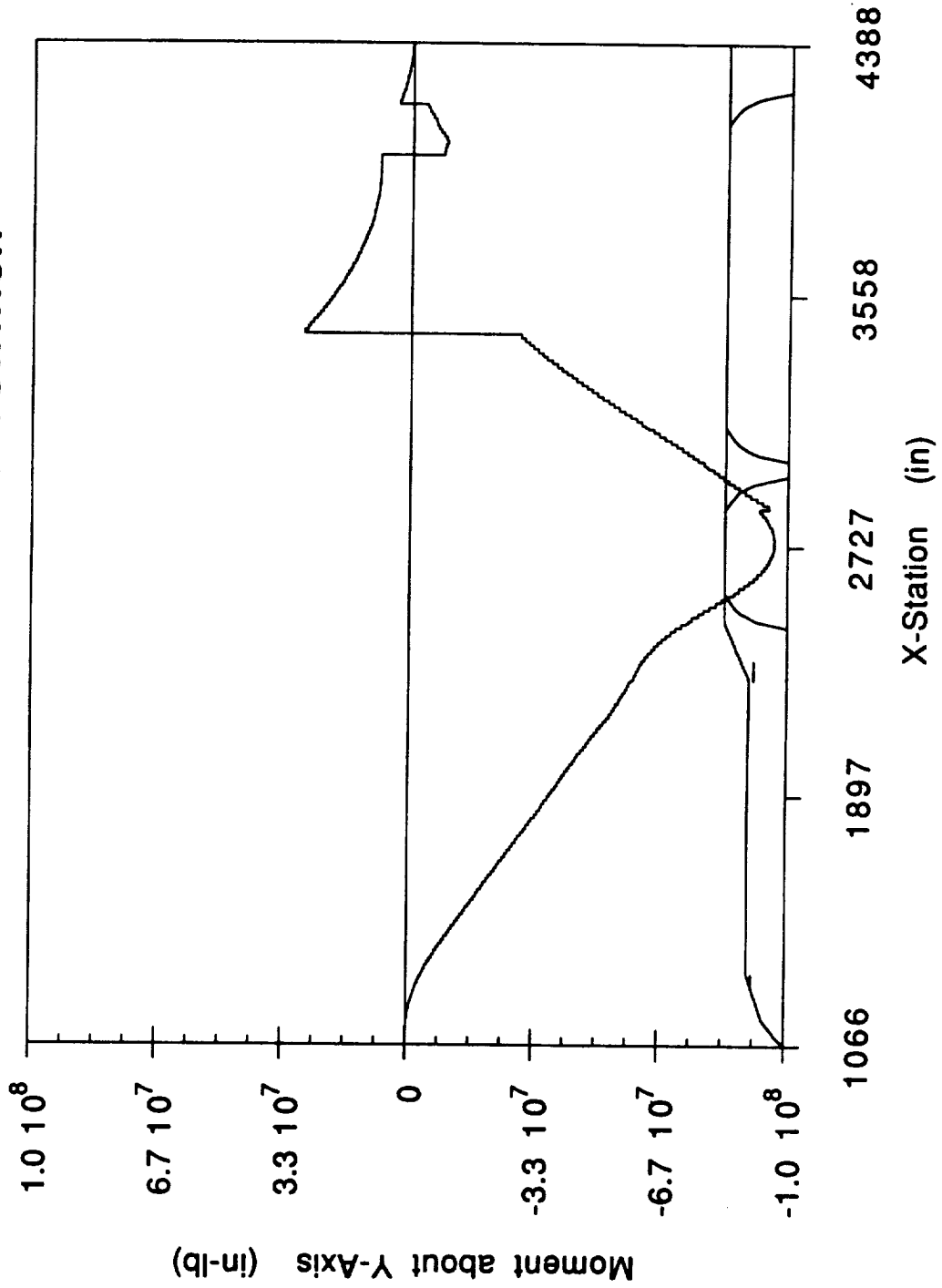

**NLS1 CORE - 10 km
Z-DIR MOMENT vs X-STATION**

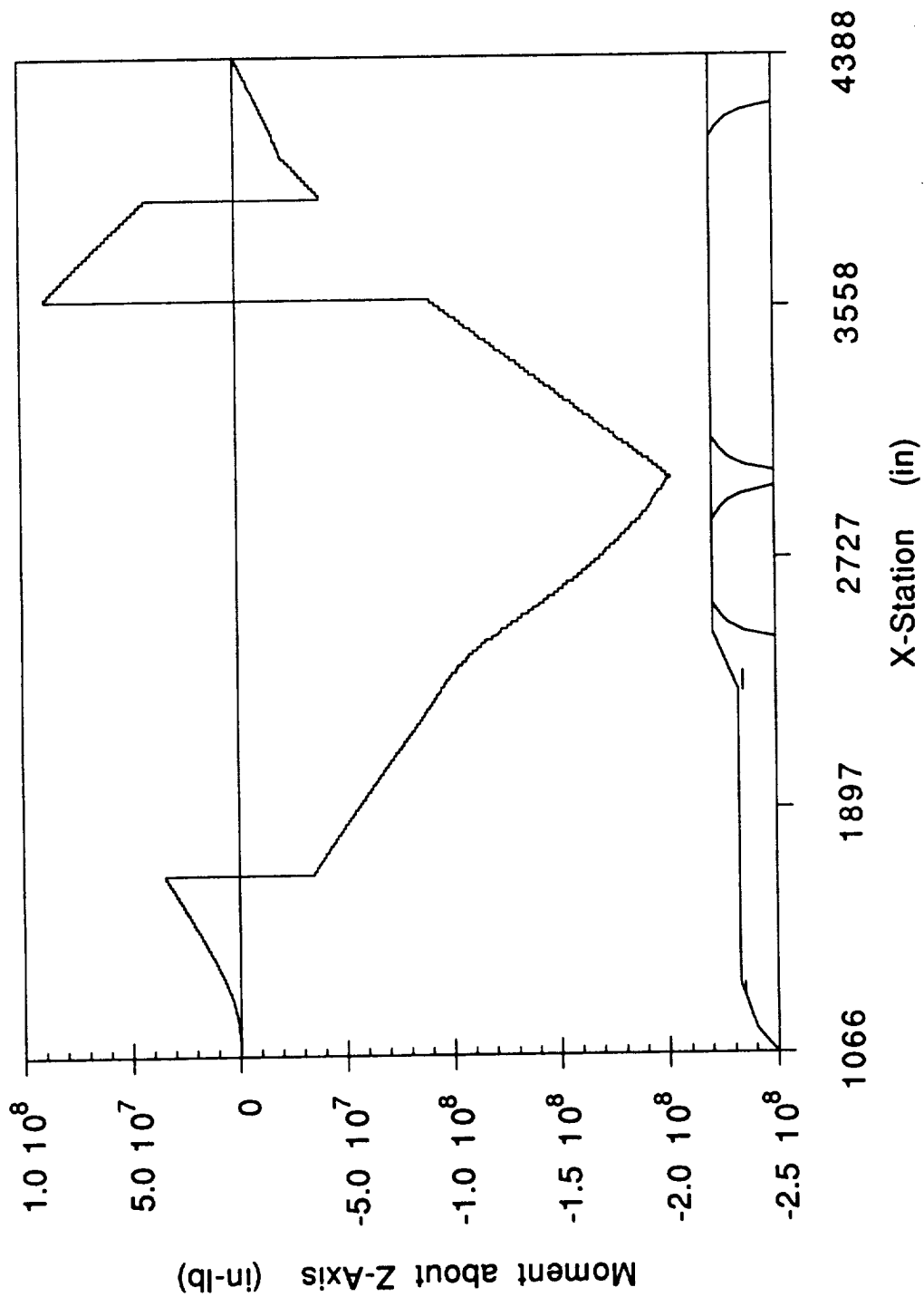

**NLS1 CORE - 11 km
NX vs X-STATION**

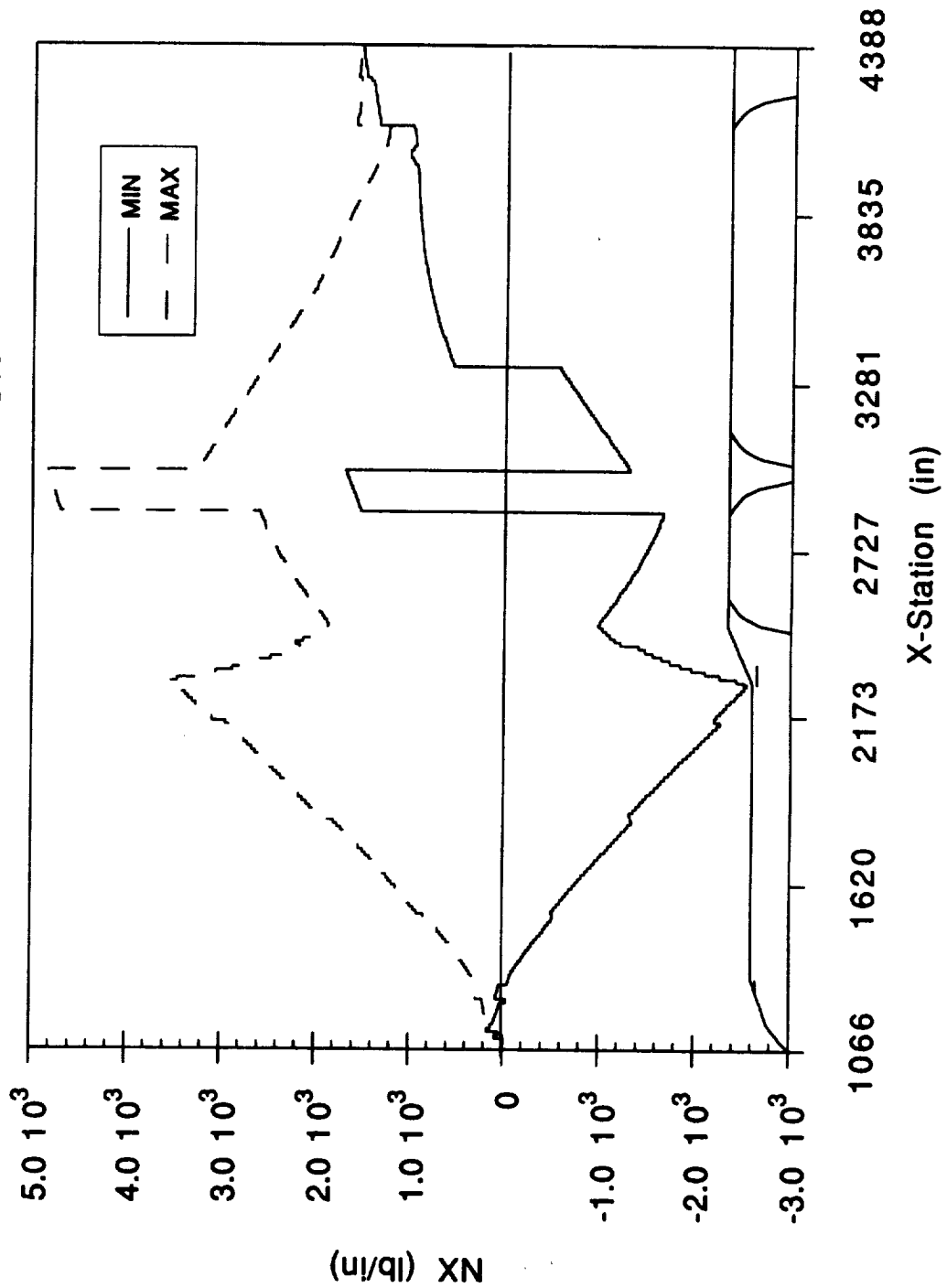

NLS1 CORE - 11 km NV vs X-STATION

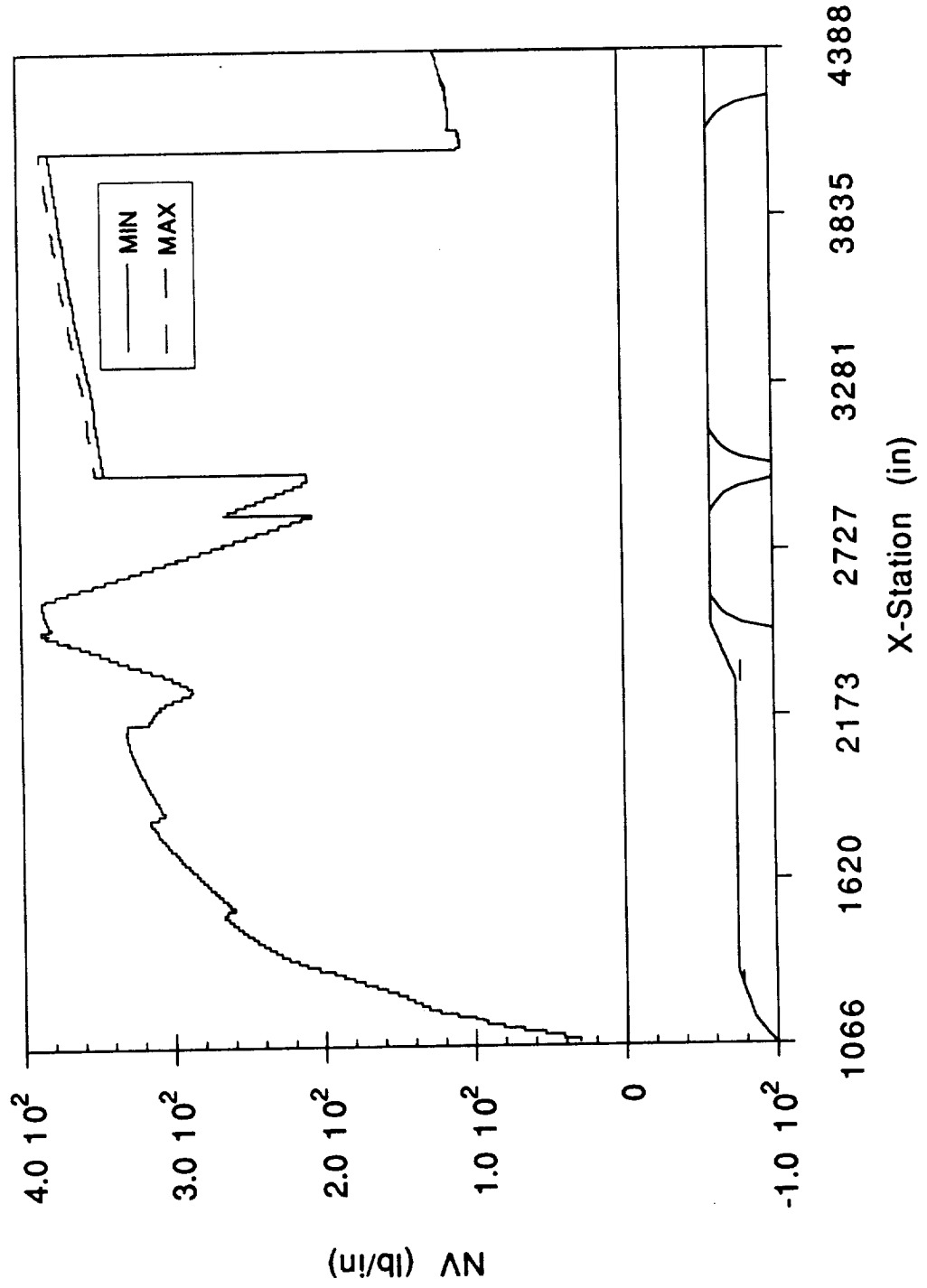

**NLS1 CORE - 11 km
AXIAL SHEAR vs X-STATION**

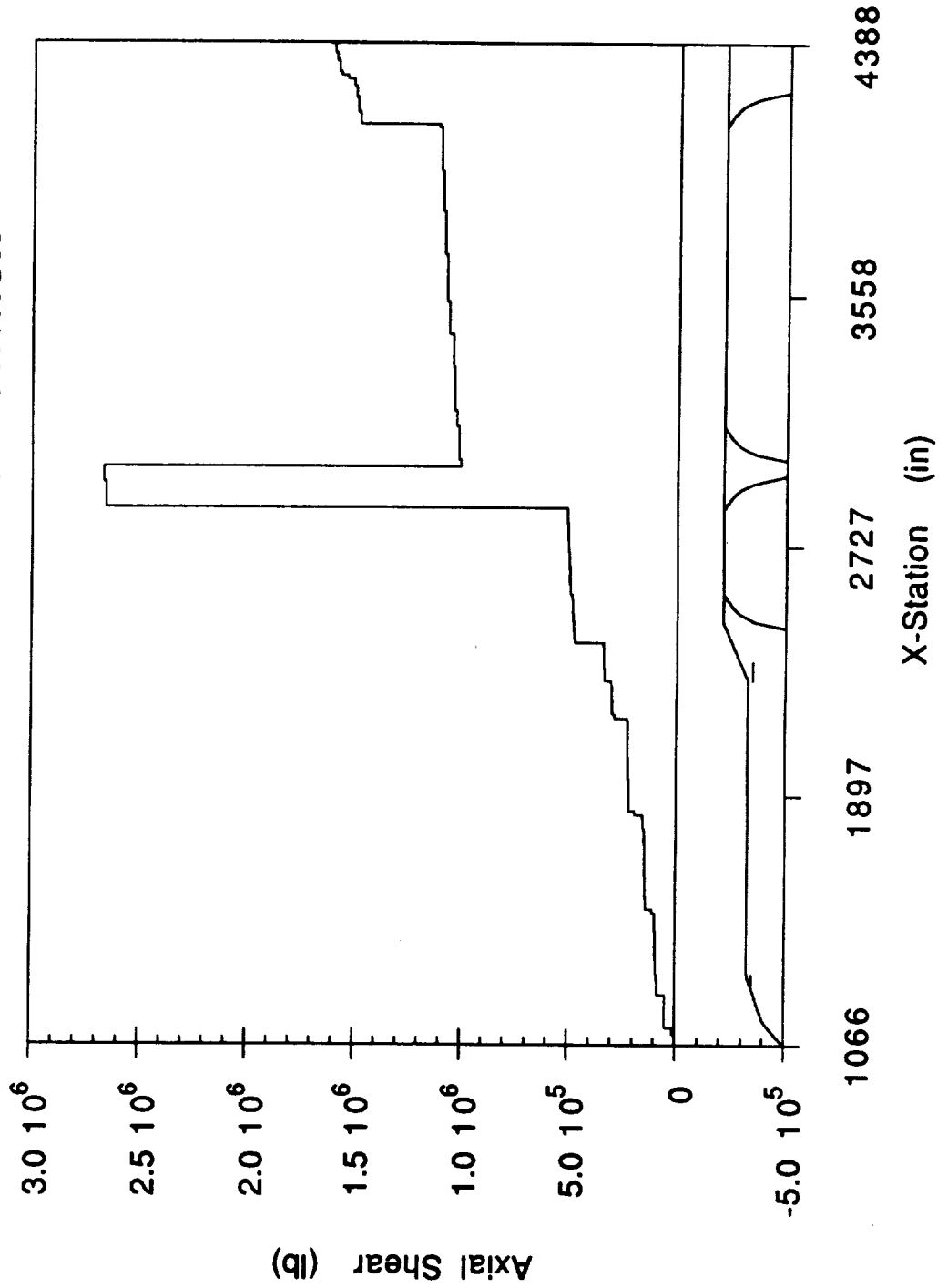

**NLS1 CORE - 11 km
Y-DIR SHEAR vs X-STATION**

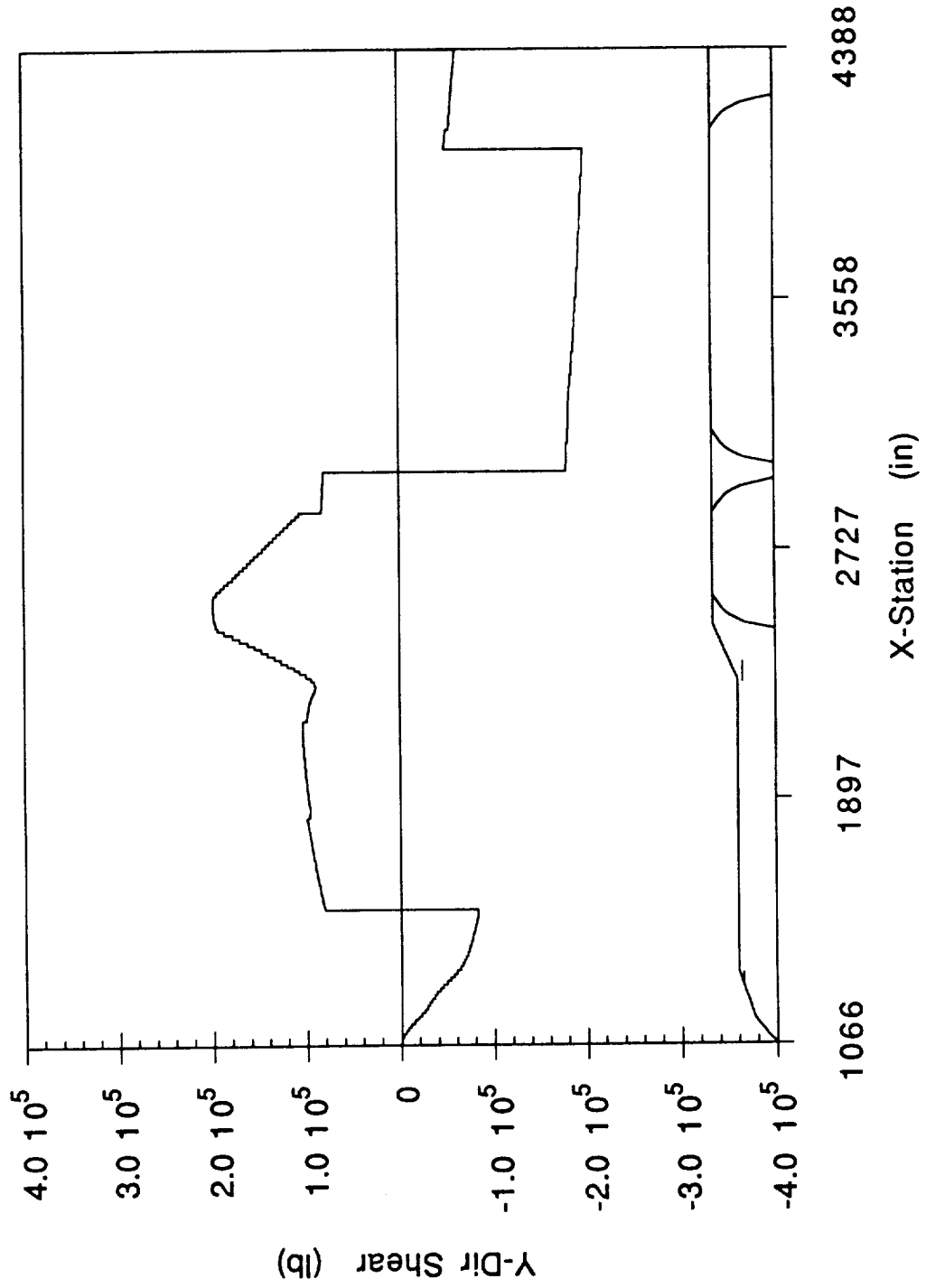

NLS1 CORE - 11 km Z-DIR SHEAR vs X-STATION

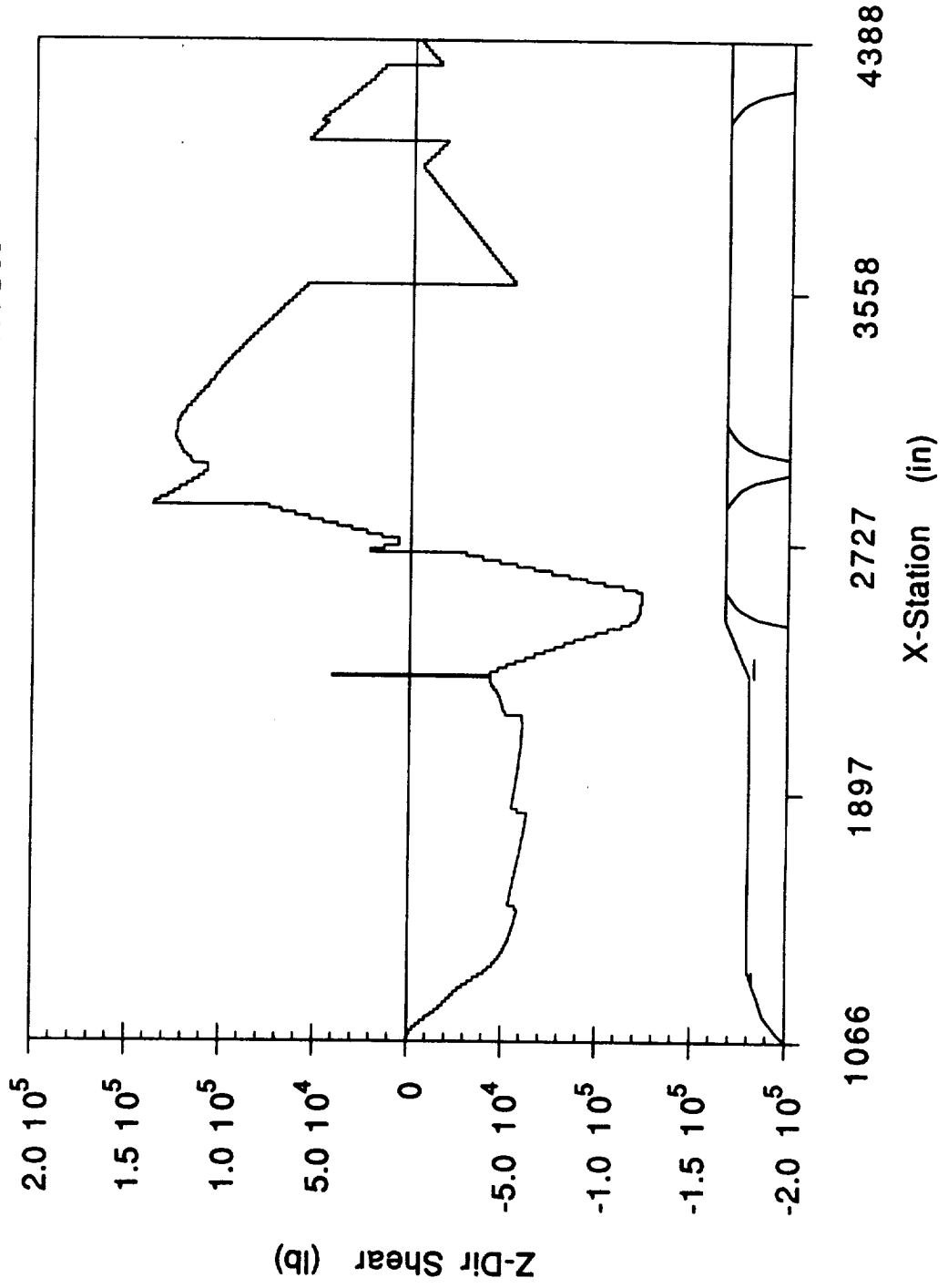

(((

**NLS1 CORE - 11 km
Y-DIR MOMENT vs X-STATION**

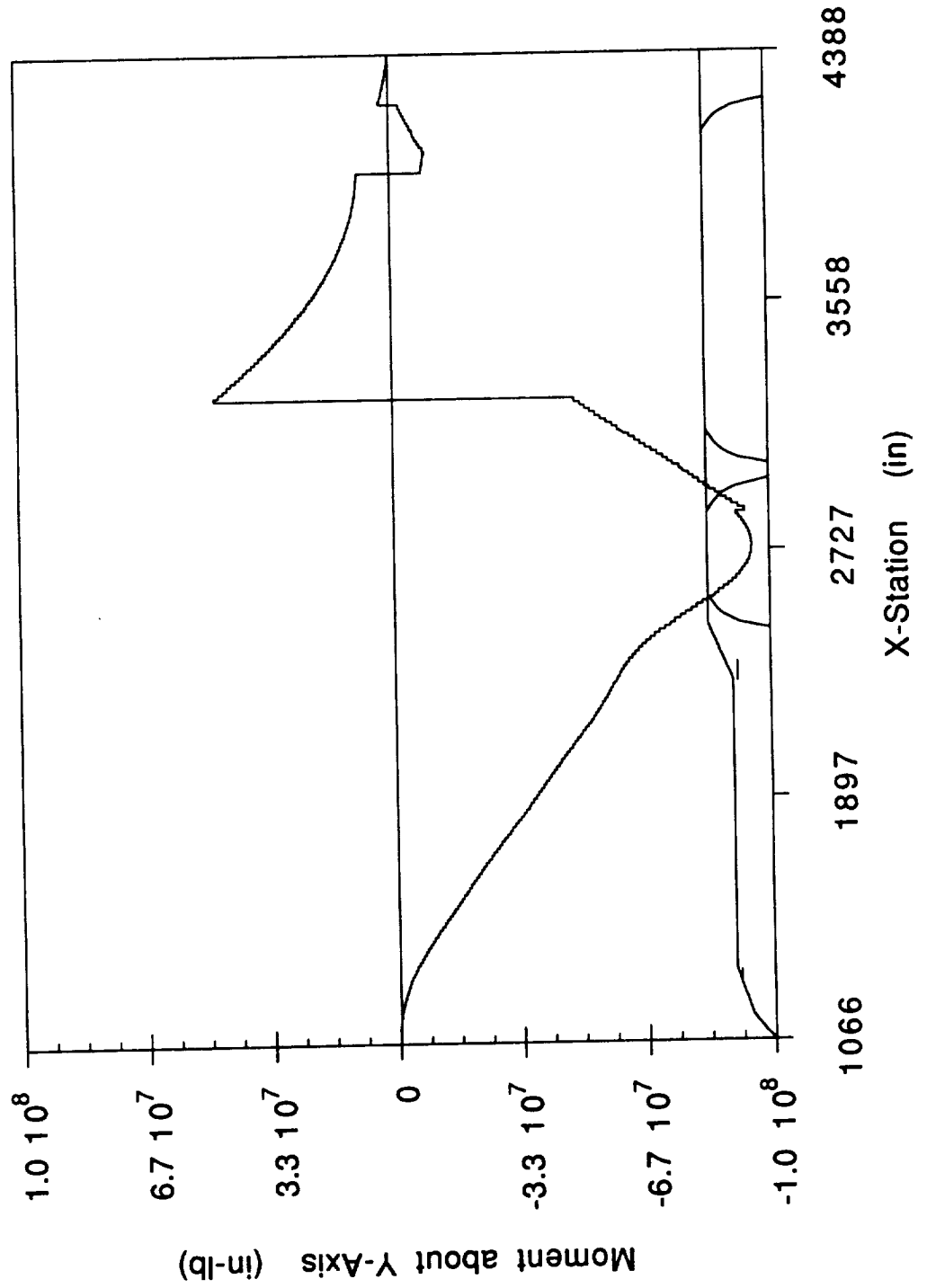

**NLS1 CORE - 11 km
Z-DIR MOMENT vs X-STATION**

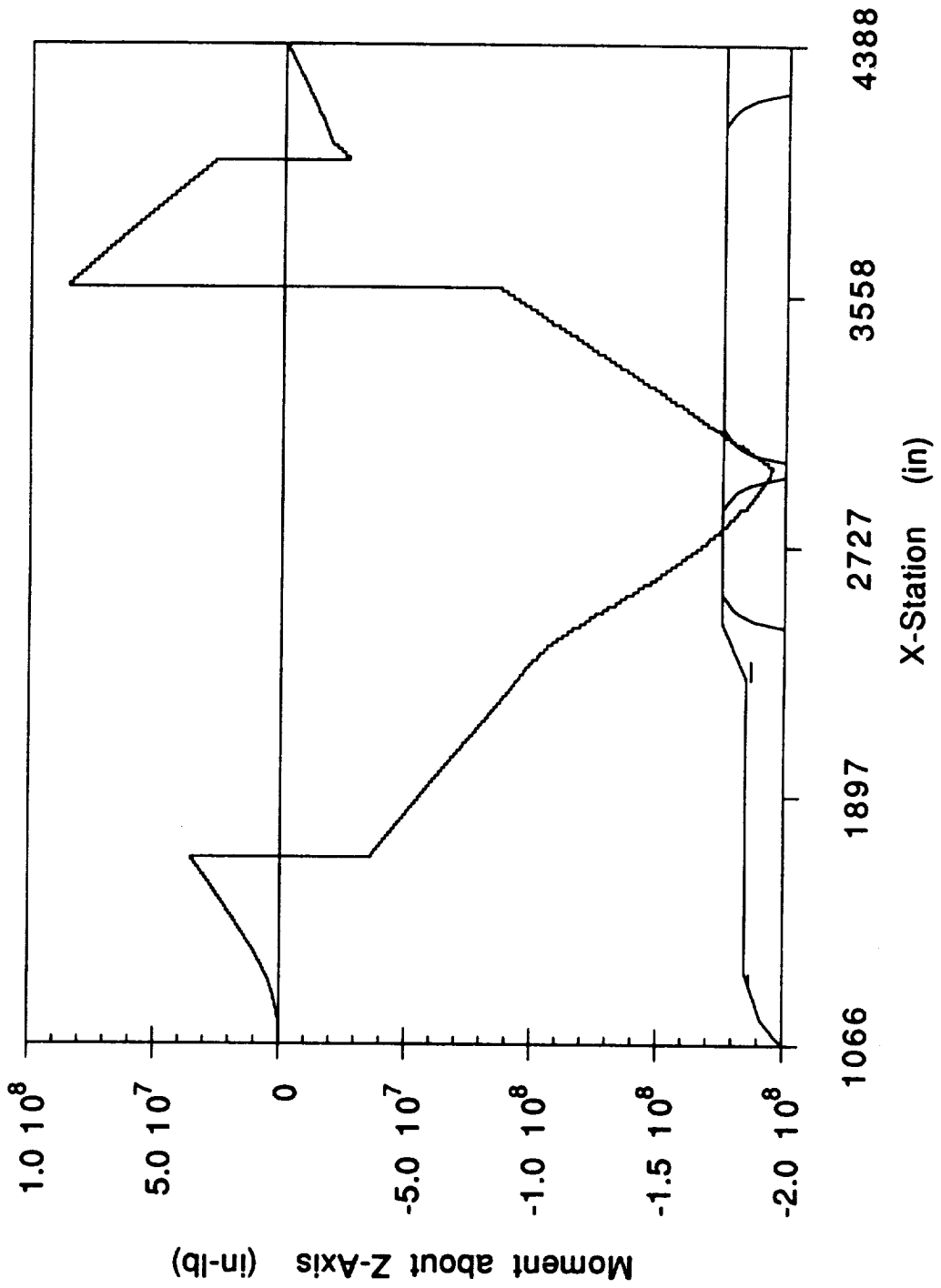

NLS1 CORE - 12 km NX vs X-STATION

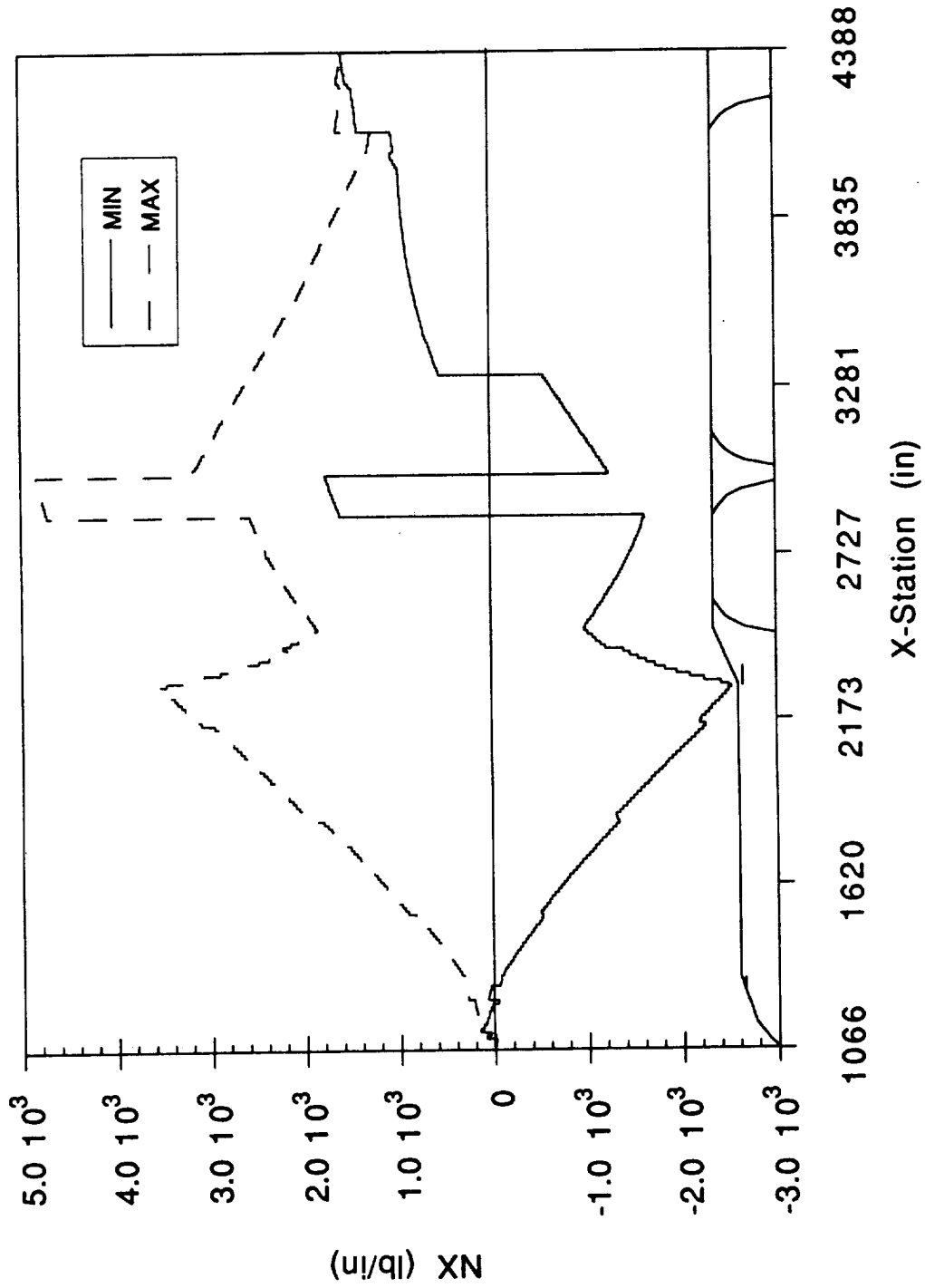

**NLS1 CORE - 12 km
NV vs X-STATION**

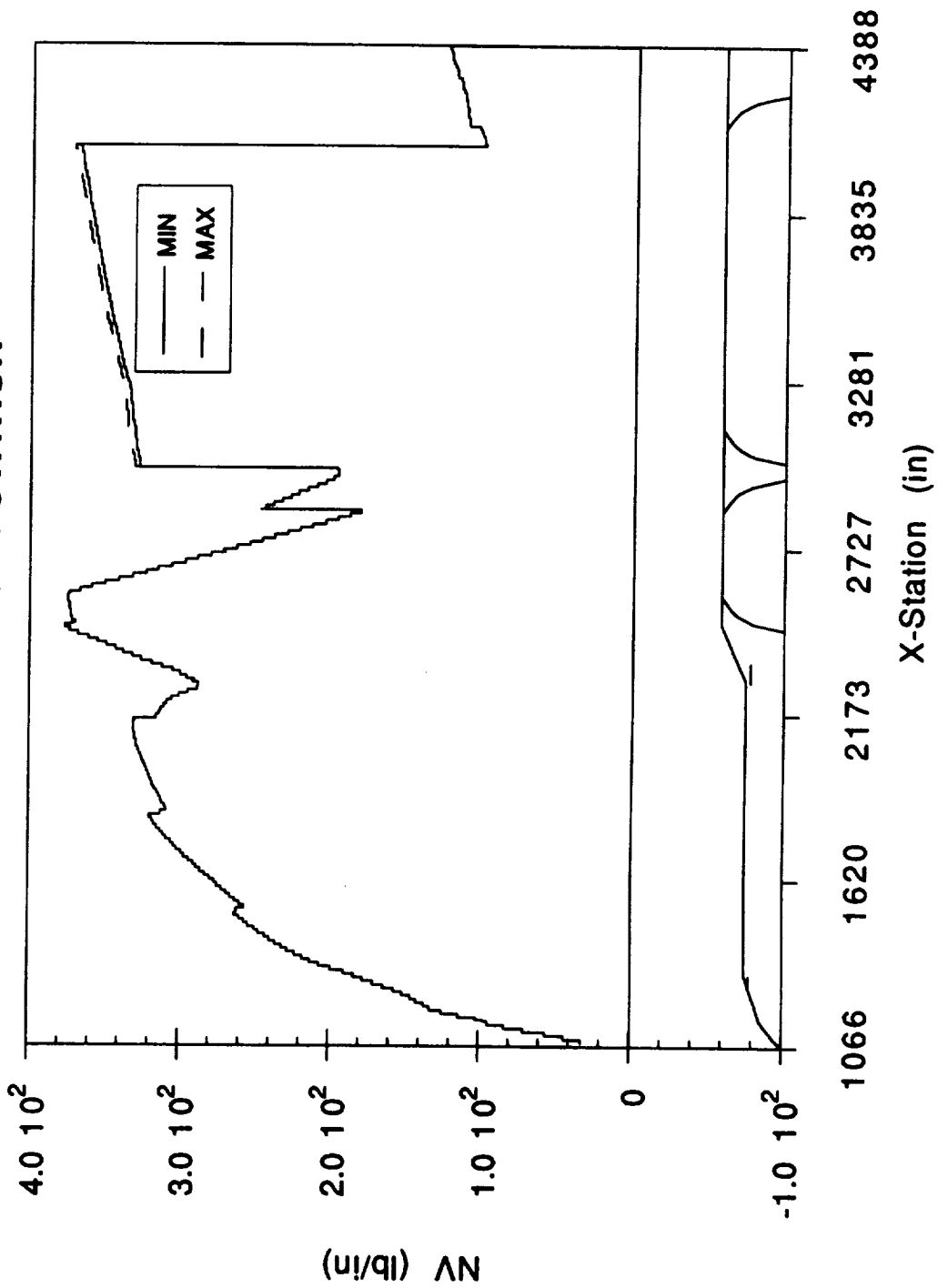

((

**NLS1 CORE - 12 km
AXIAL SHEAR vs X-STATION**

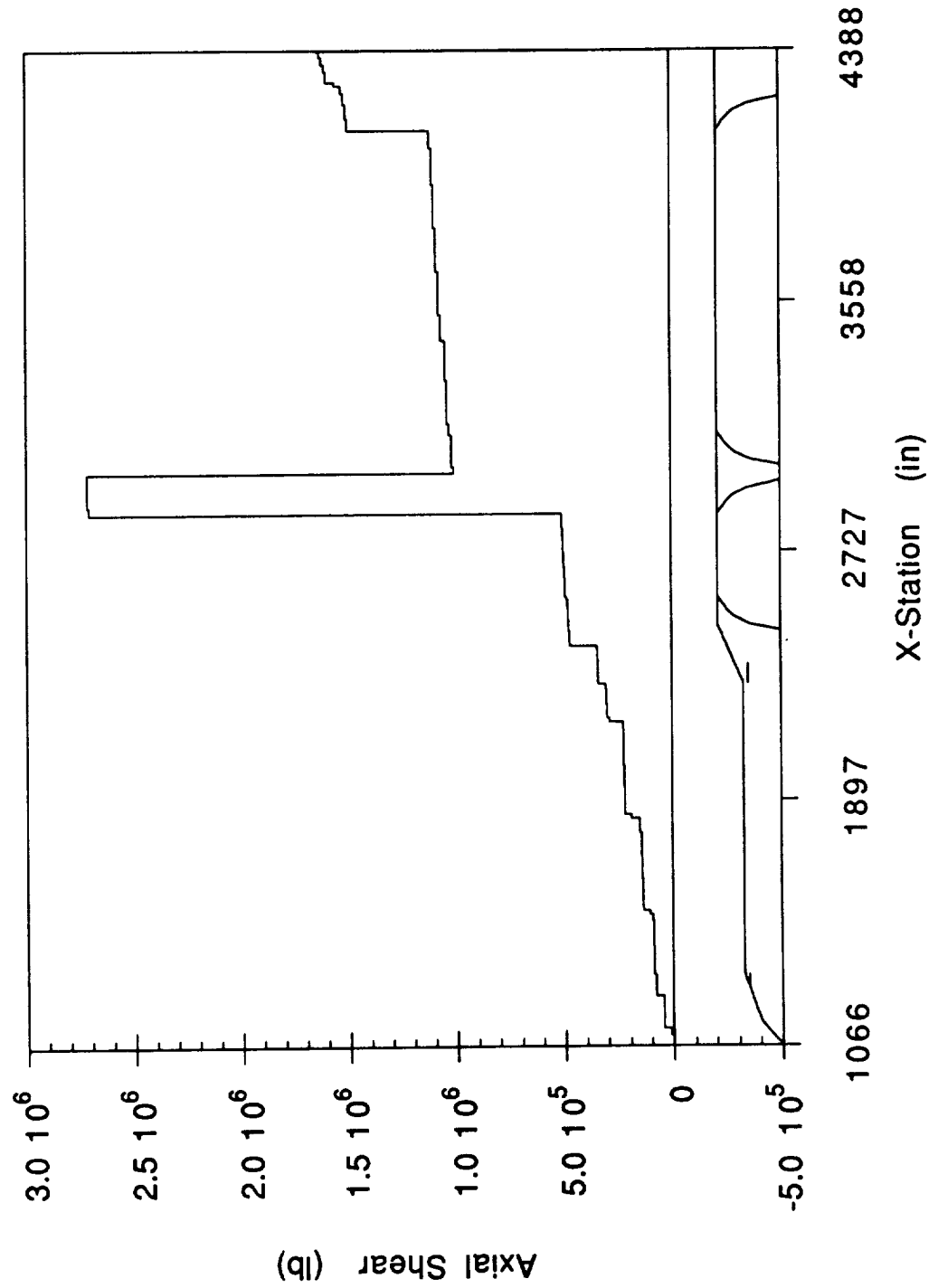

NLS1 CORE - 12km Y-DIR SHEAR vs X-STATION

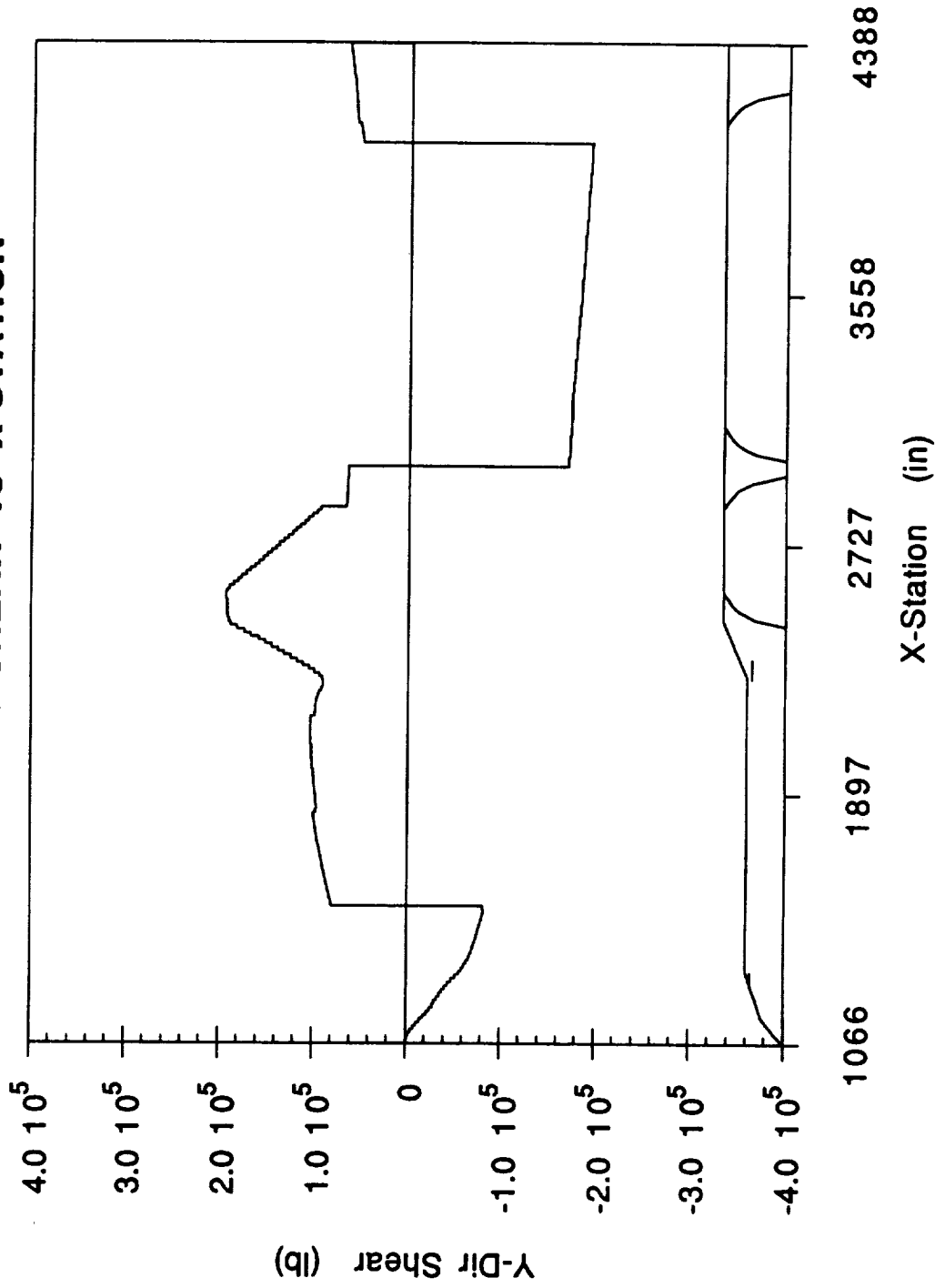

((

**NLS1 CORE - 12 km
Z-DIR SHEAR vs X-STATION**

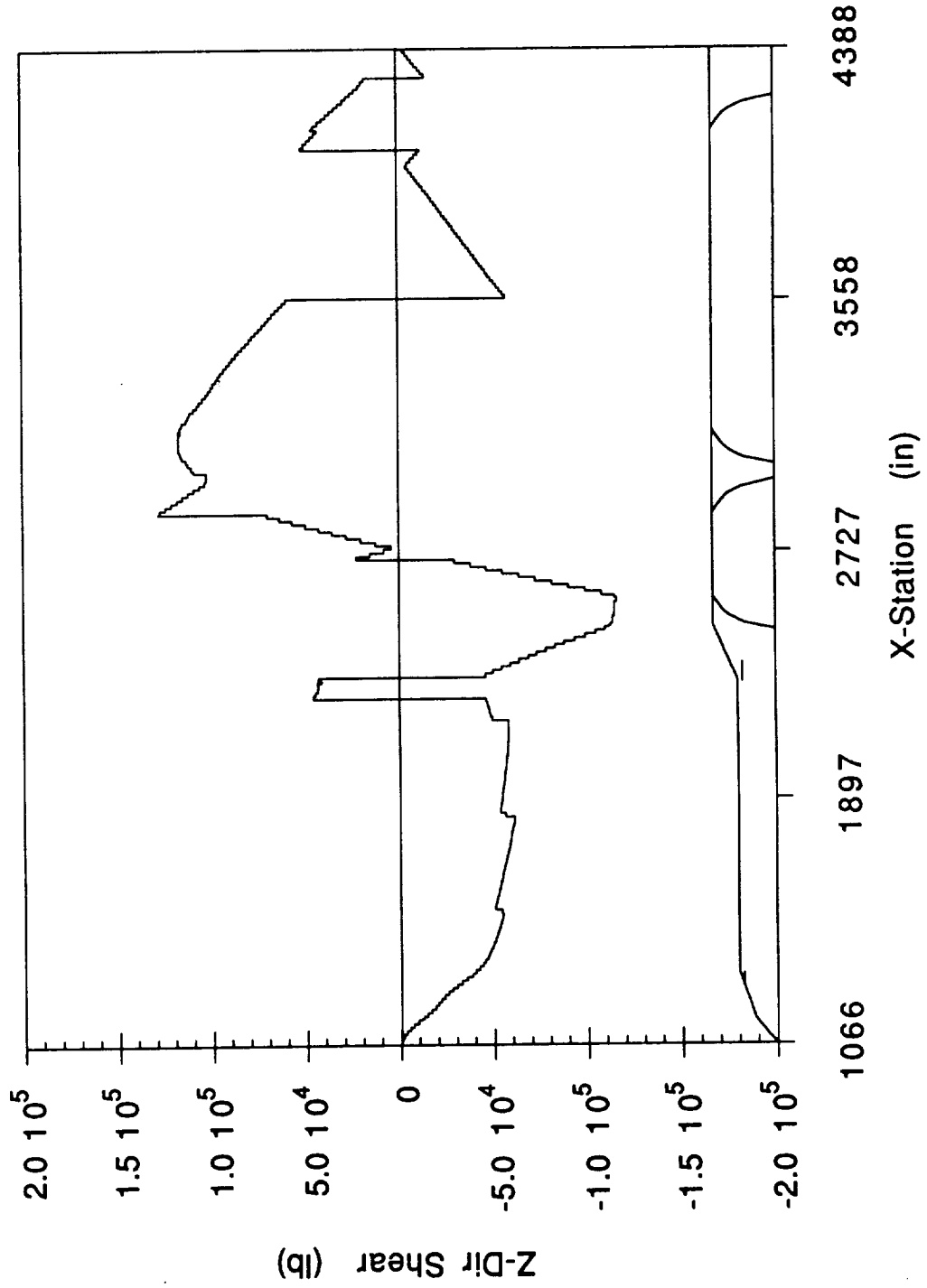

NLS1 CORE - 12 km Y-DIR MOMENT vs X-STATION

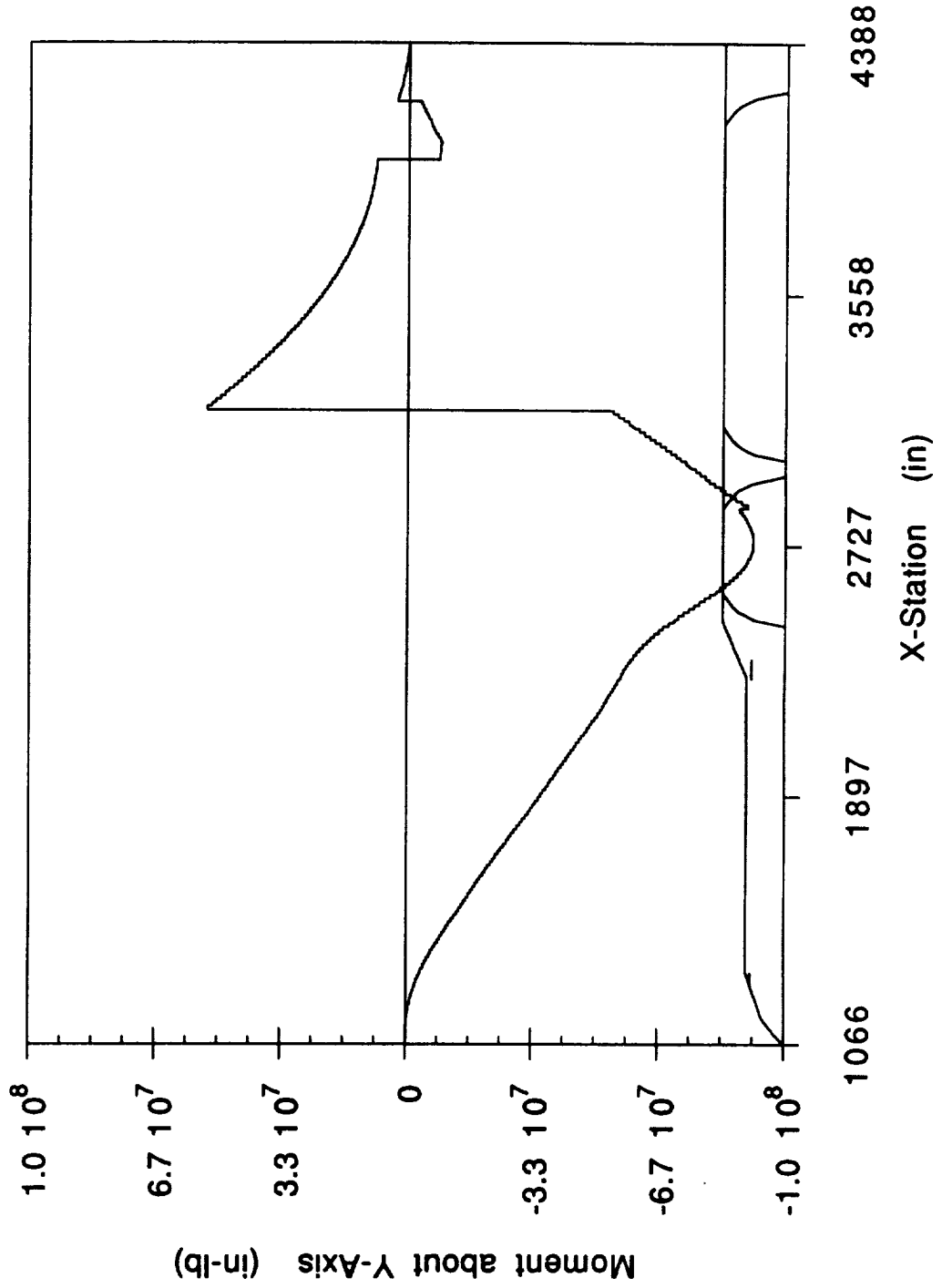

((

**NLS1 CORE - 12 km
Z-DIR MOMENT vs X-STATION**

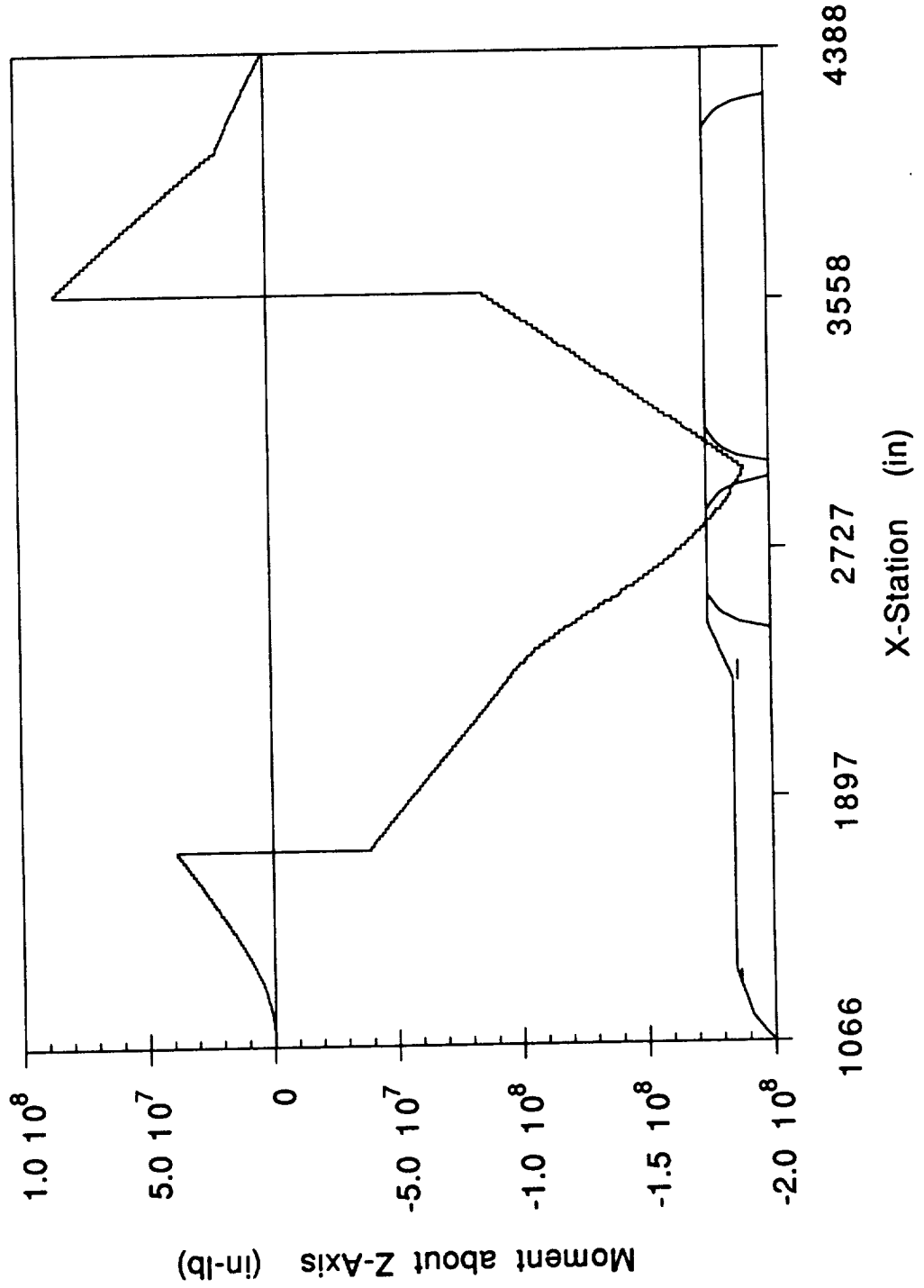

**NLS1 CORE - 13 km
NX vs X-STATION**

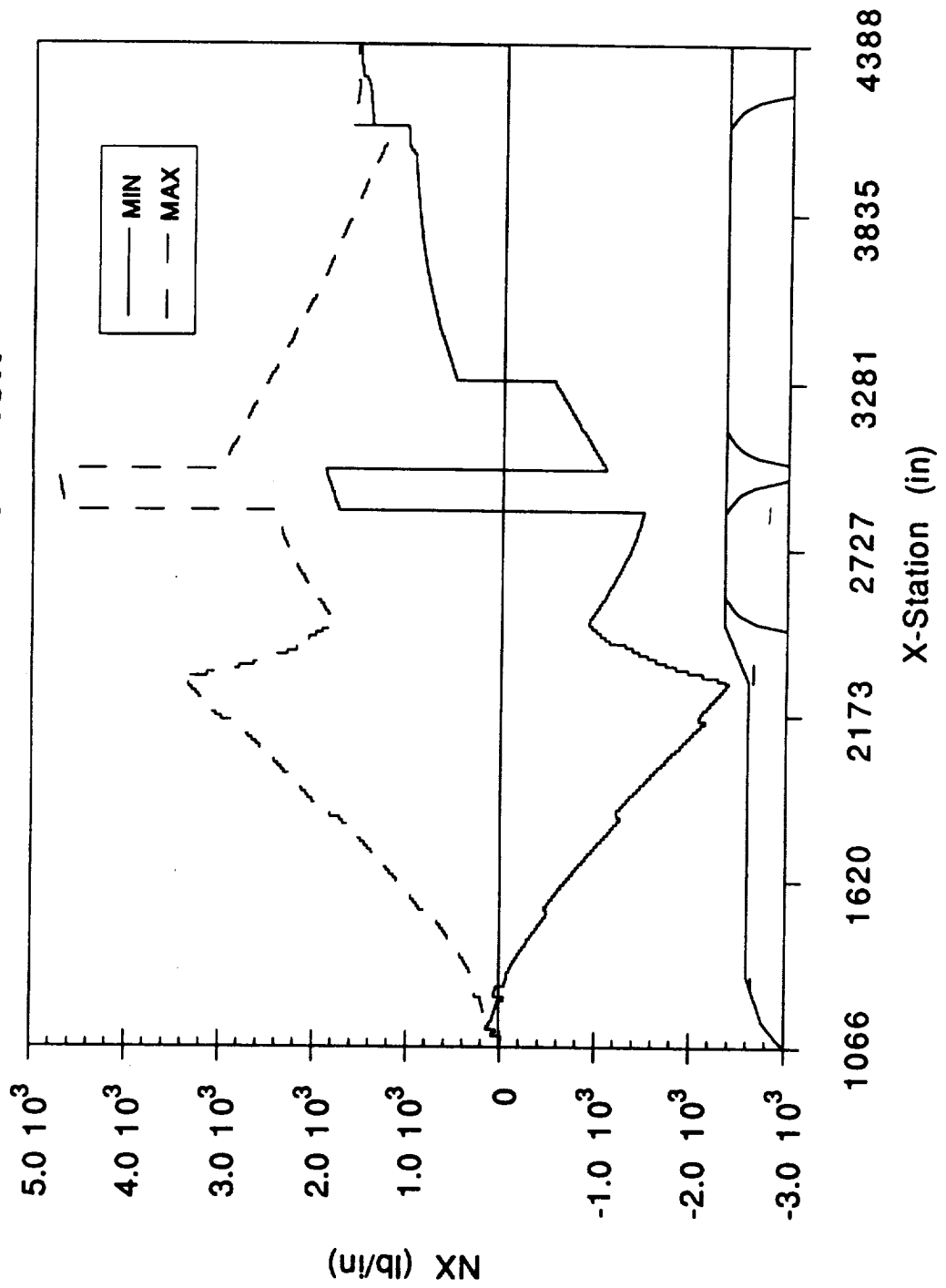

**NLS1 CORE - 13 km
NV vs X-STATION**

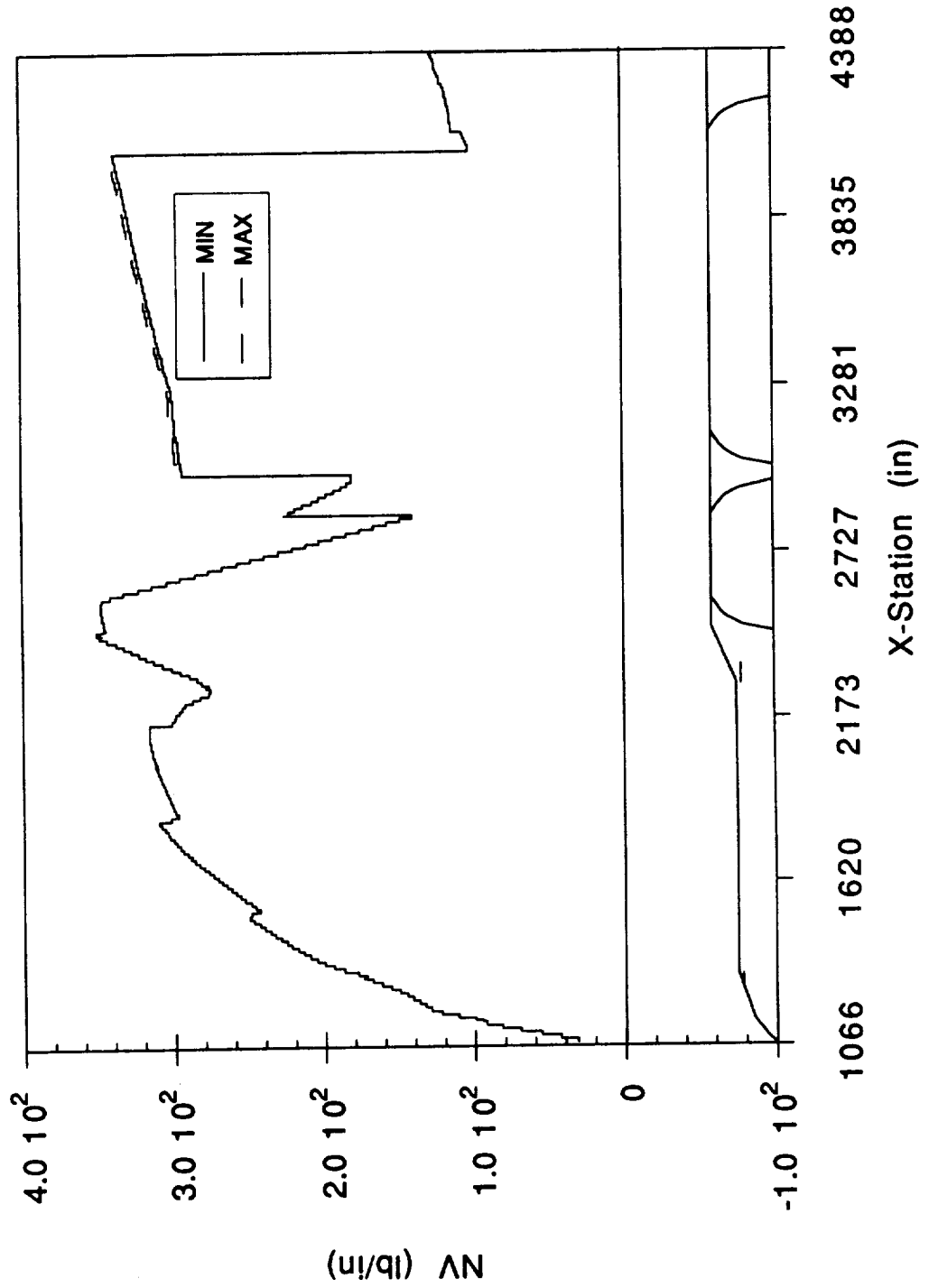

NLS1 CORE - 13 km AXIAL SHEAR vs X-STATION

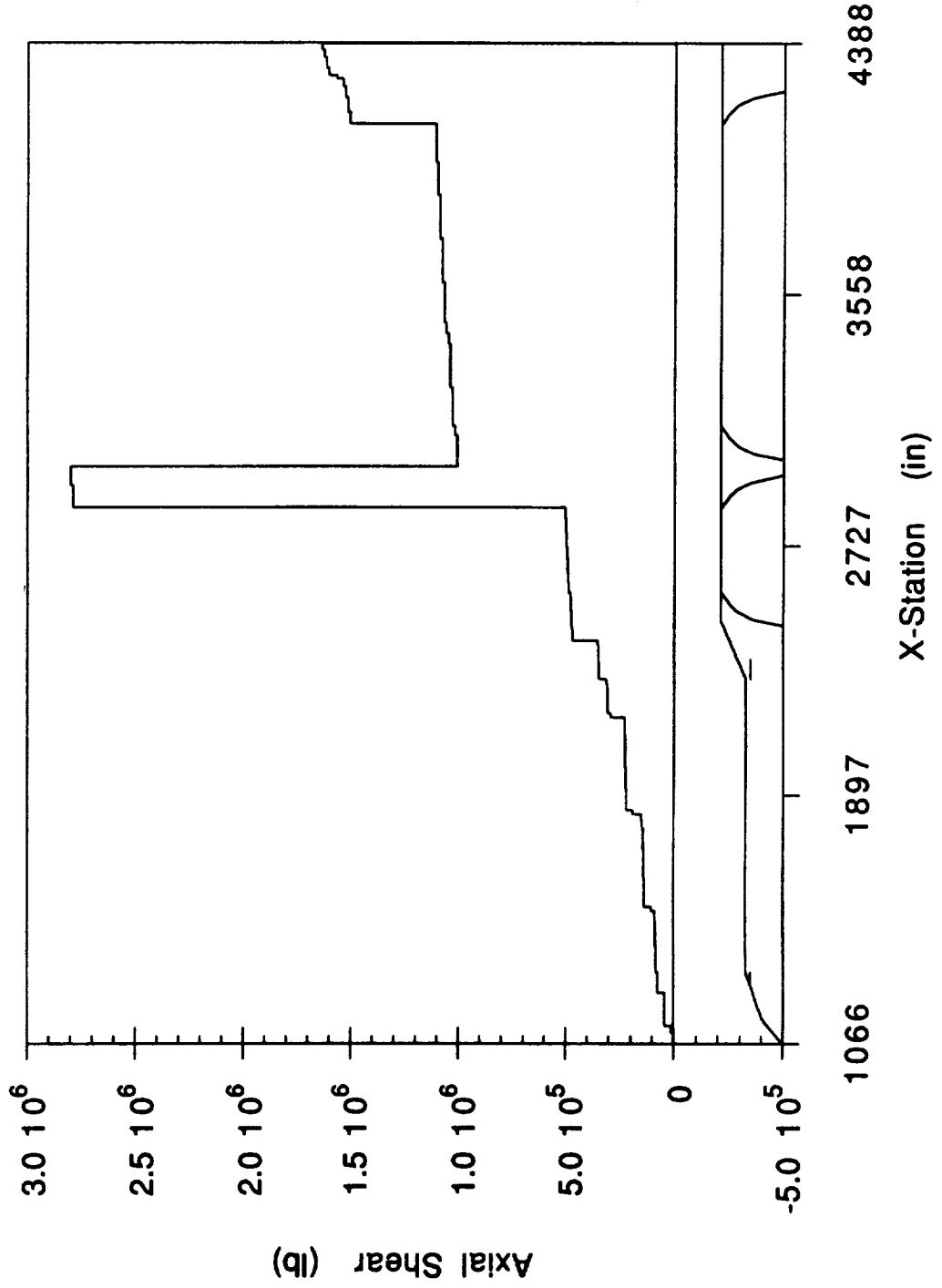

(

(

(

NLS1 CORE - 13 km
Y-DIR SHEAR VS X-STATION

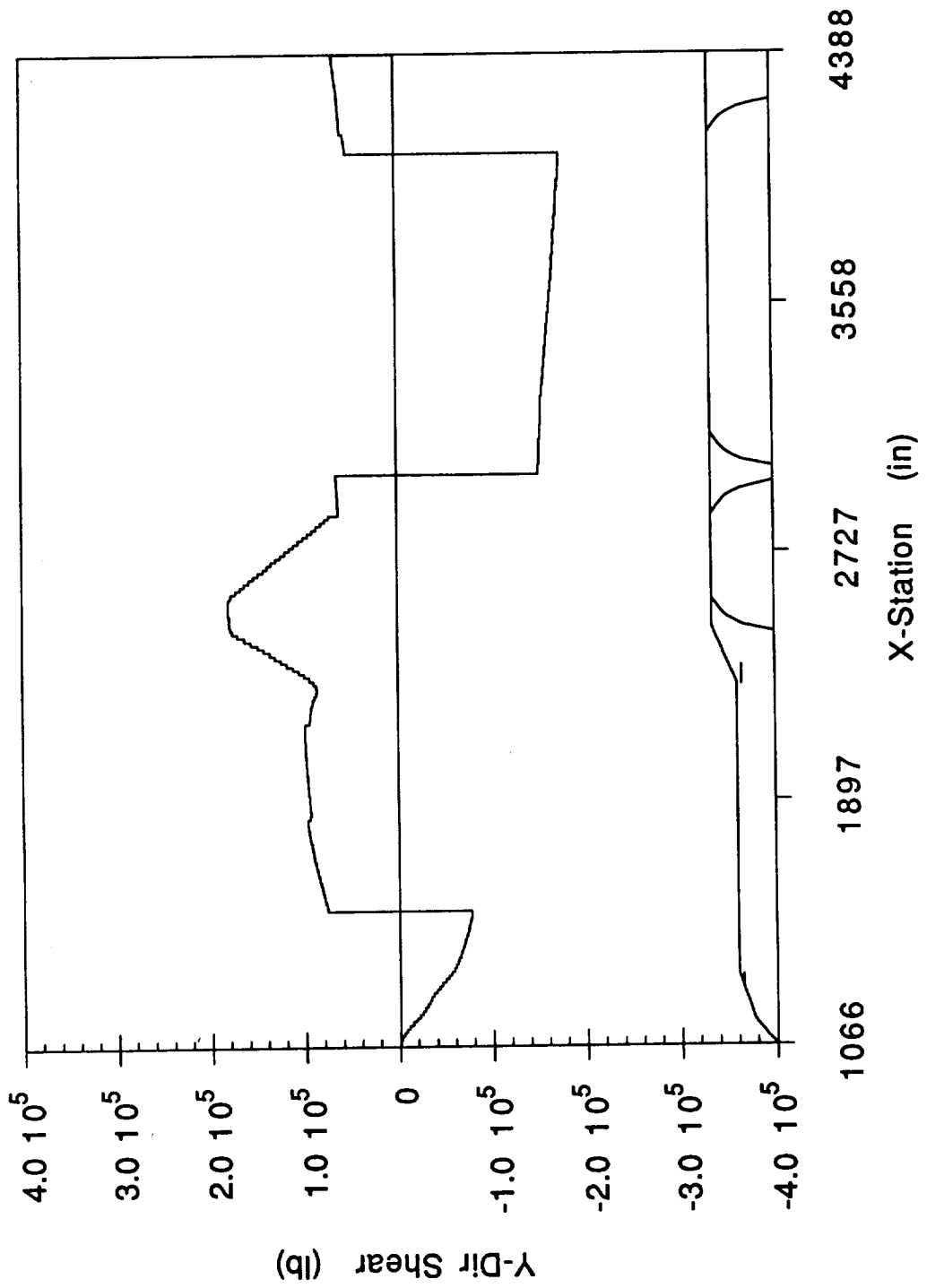

**NLS1 CORE - 13 km
Z-DIR SHEAR vs X-STATION**

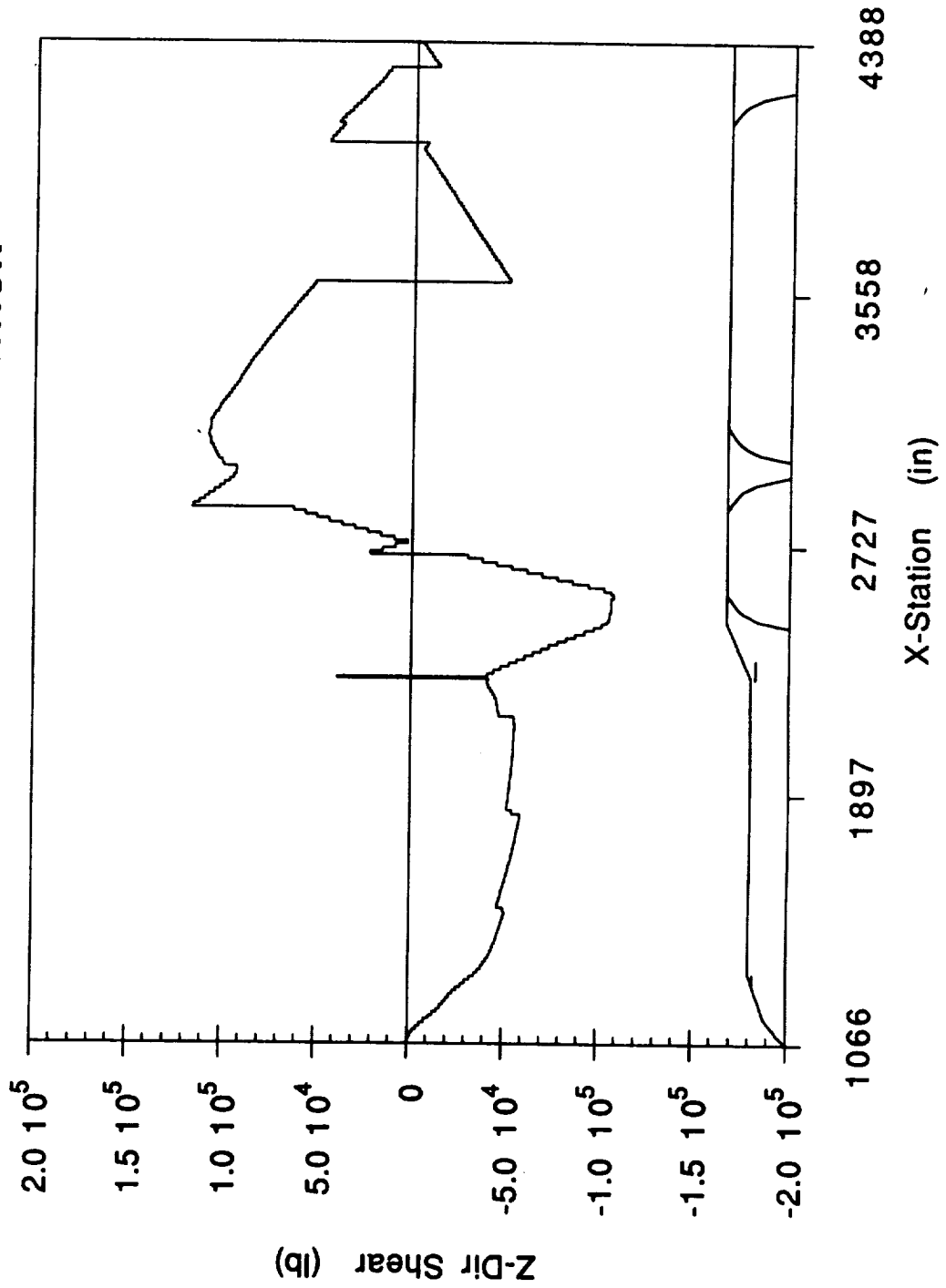

((

**NLS1 CORE - 13 km
Y-DIR MOMENT vs X-STATION**

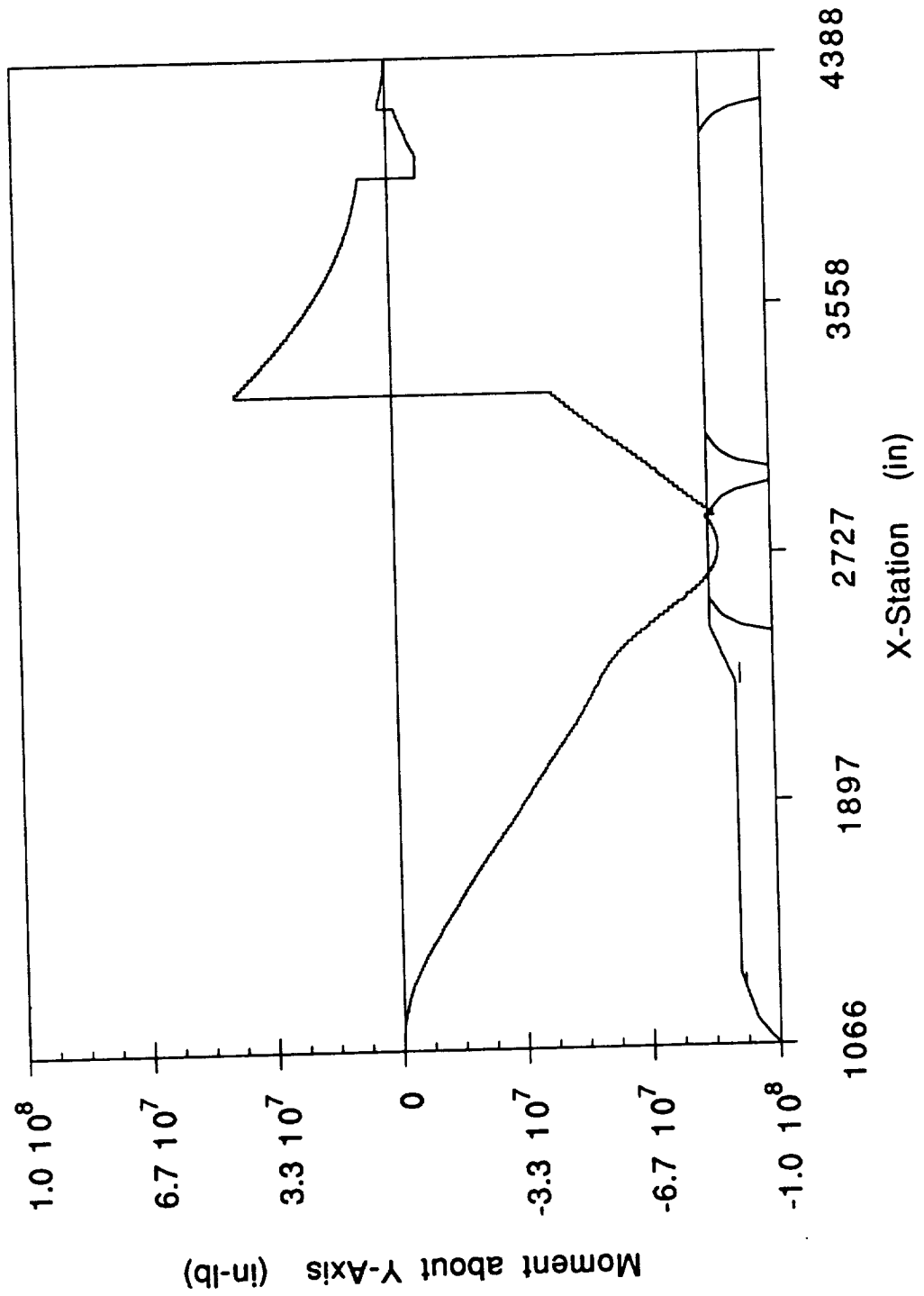

NLS1 CORE - 13 km Z-DIR MOMENT vs X-STATION

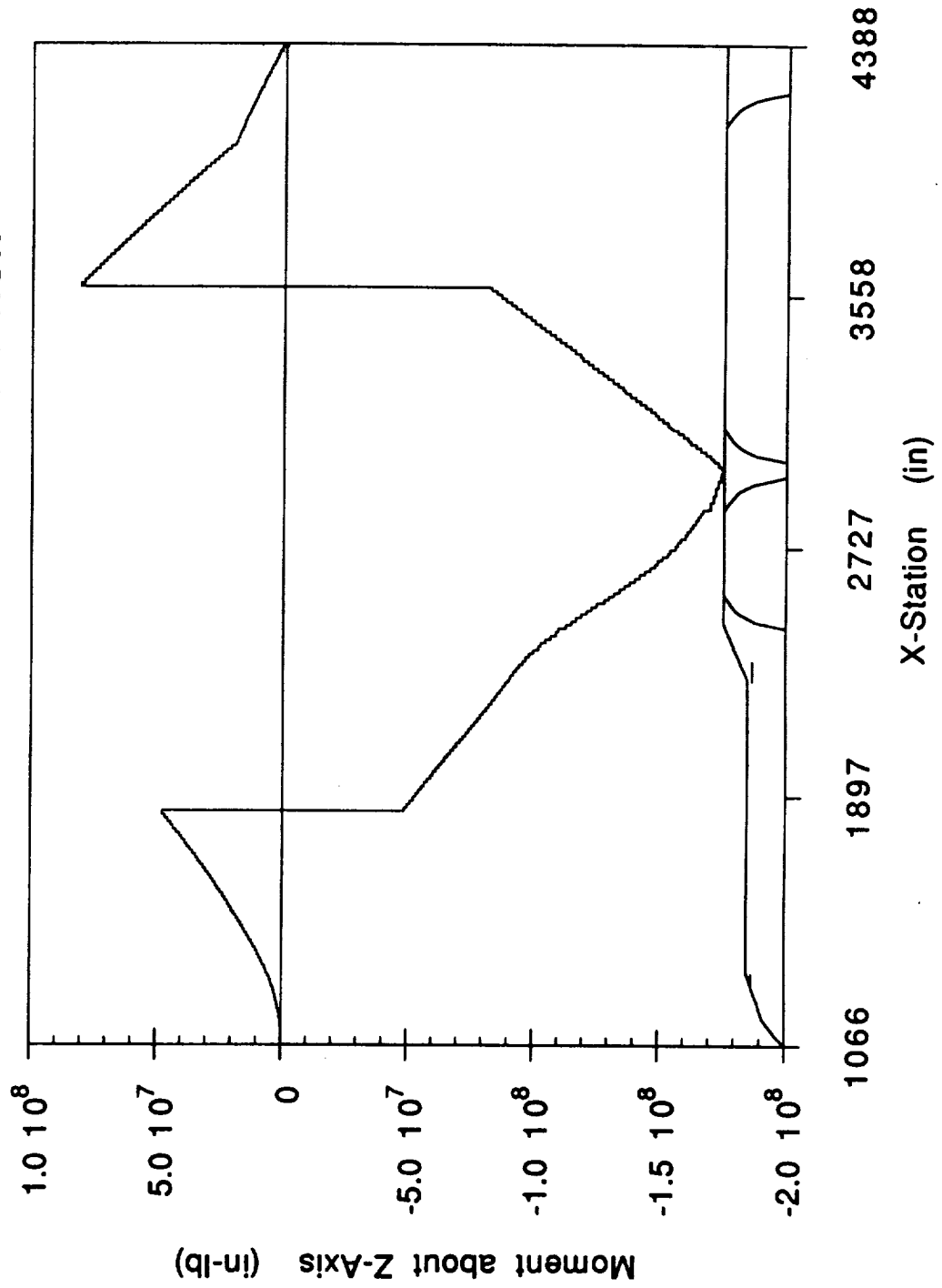

(((

**NLS1 CORE - 15 km
NX vs X-STATION**

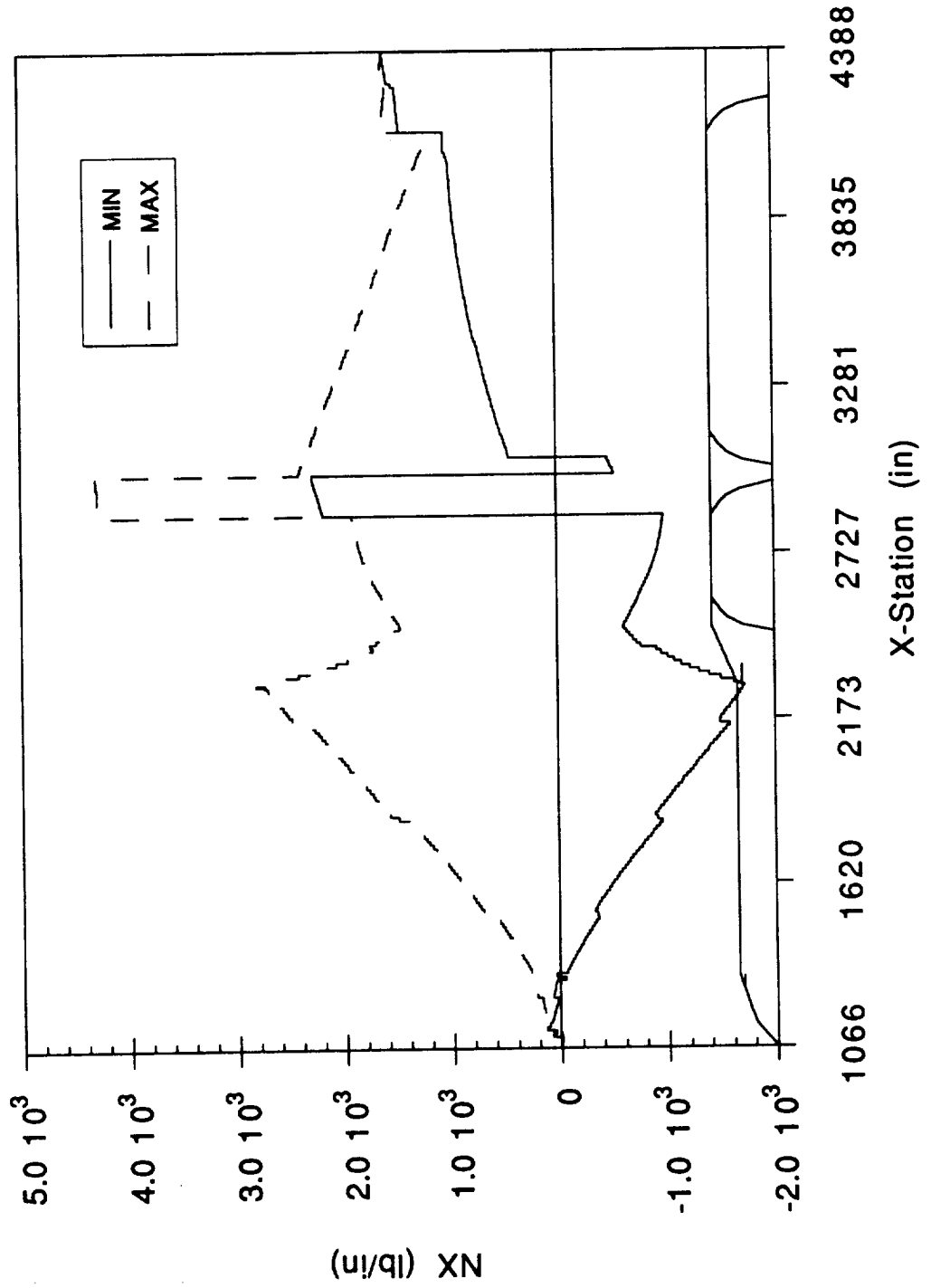

NLS1 CORE - 15 km NV vs X-STATION

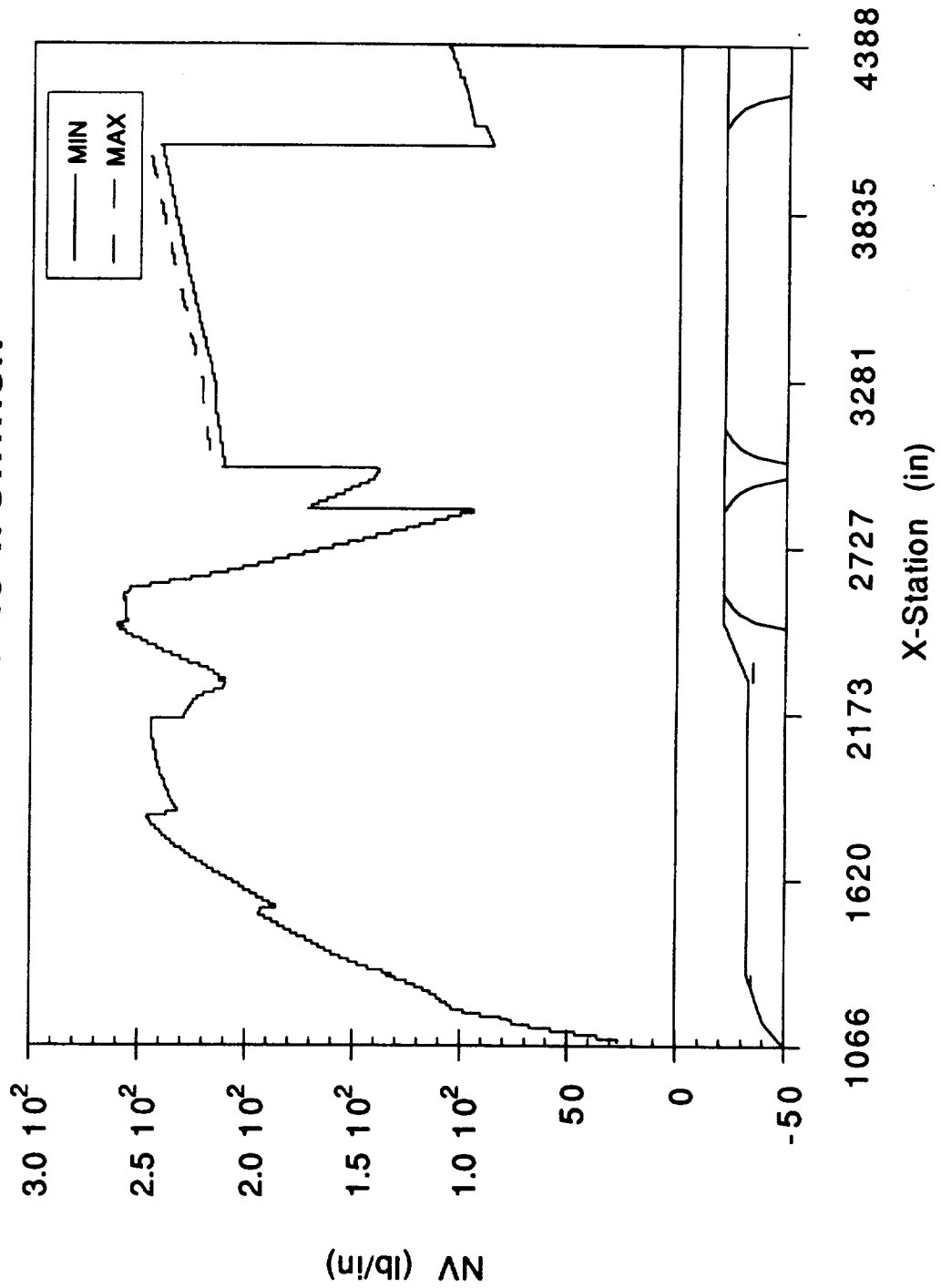

(

(

(

**NLS1 CORE - 15 km
AXIAL SHEAR VS X-STATION**

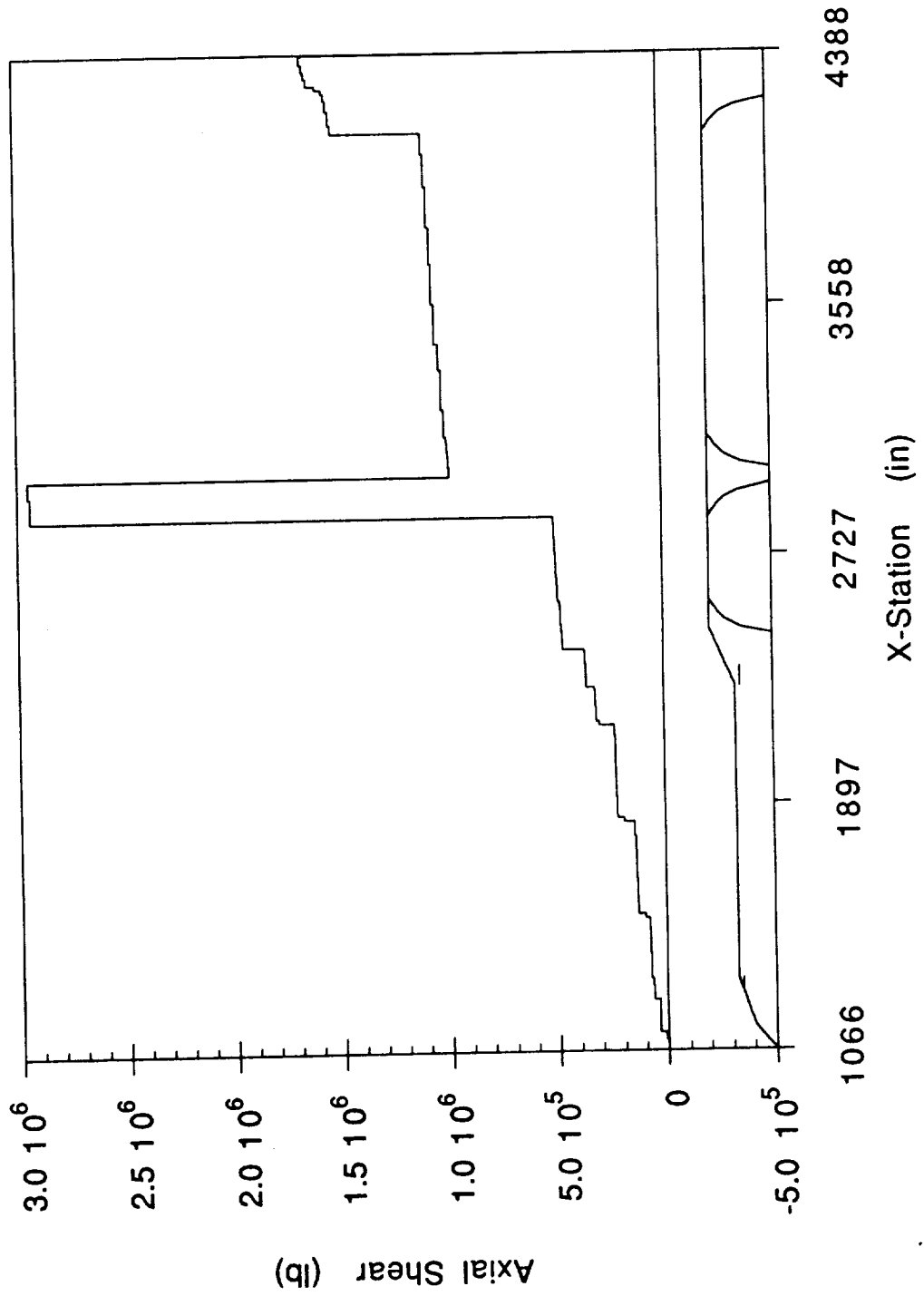

NLS1 CORE - 15 km Y-DIR SHEAR vs X-STATION

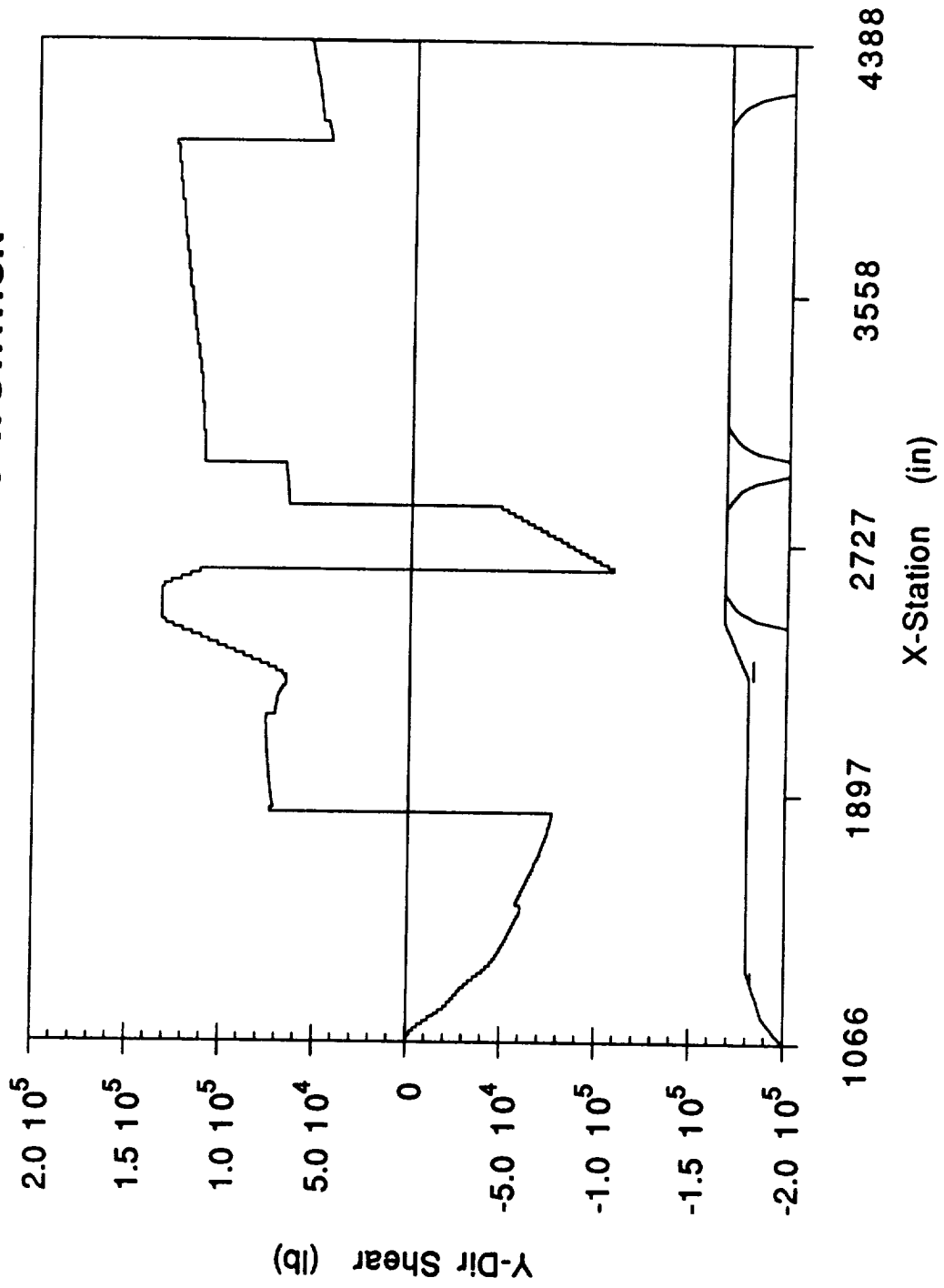

((

**NLS1 CORE - 15 km
Z-DIR SHEAR vs X-STATION**

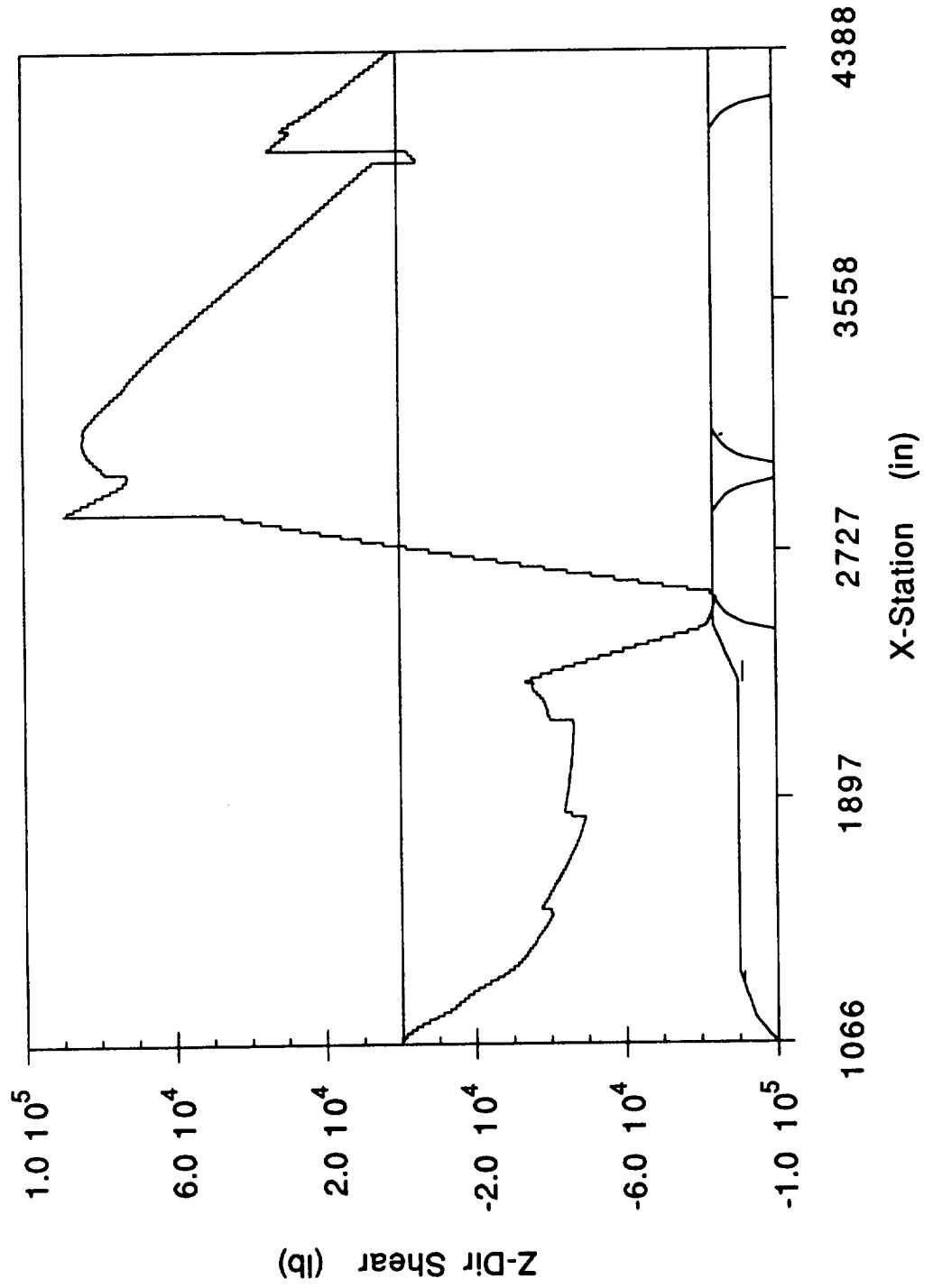

NLS1 CORE - 15 km
Y-DIR MOMENT vs X-STATION

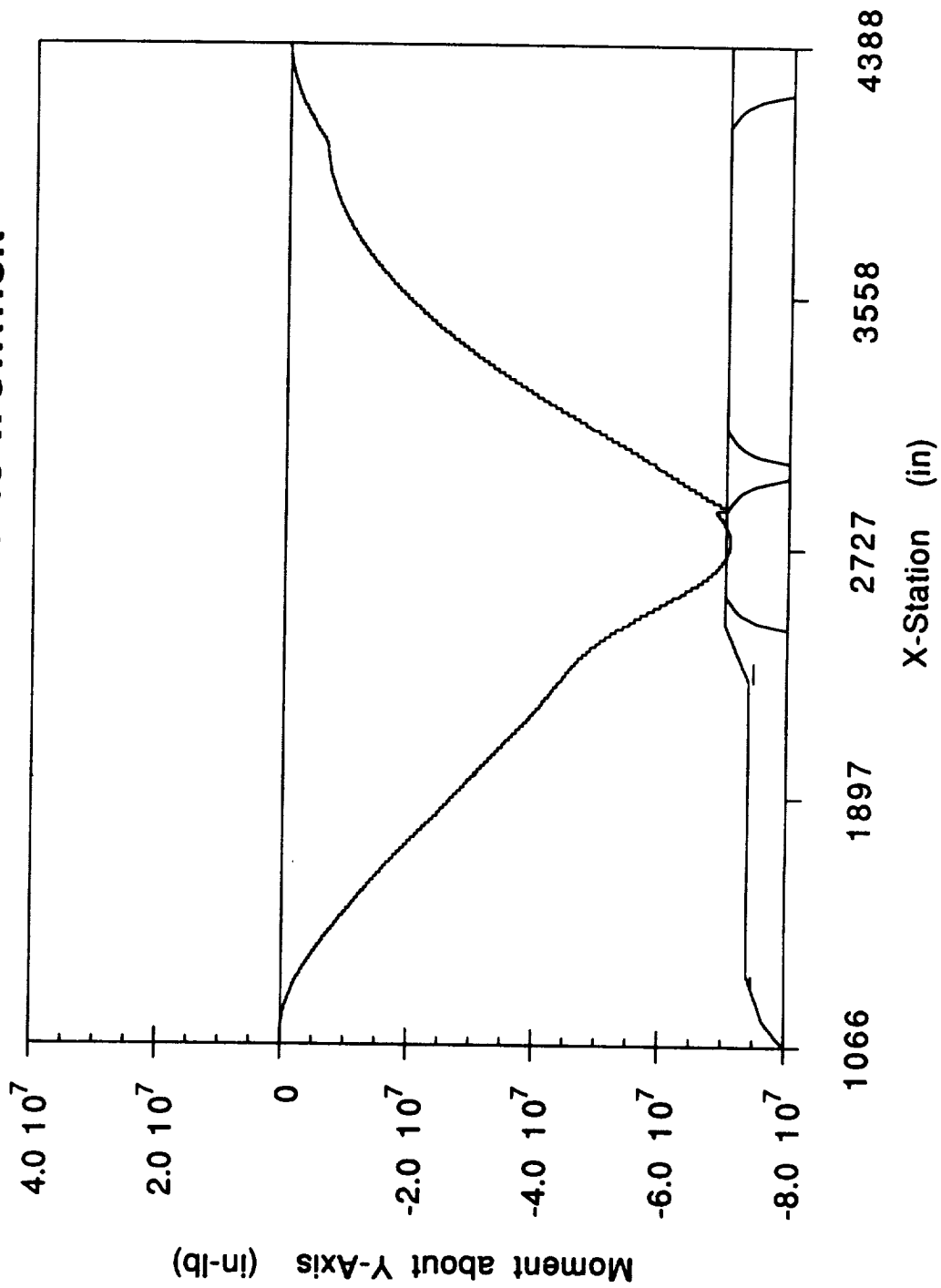

**NLS1 CORE - 15 km
Z-DIR MOMENT vs X-STATION**

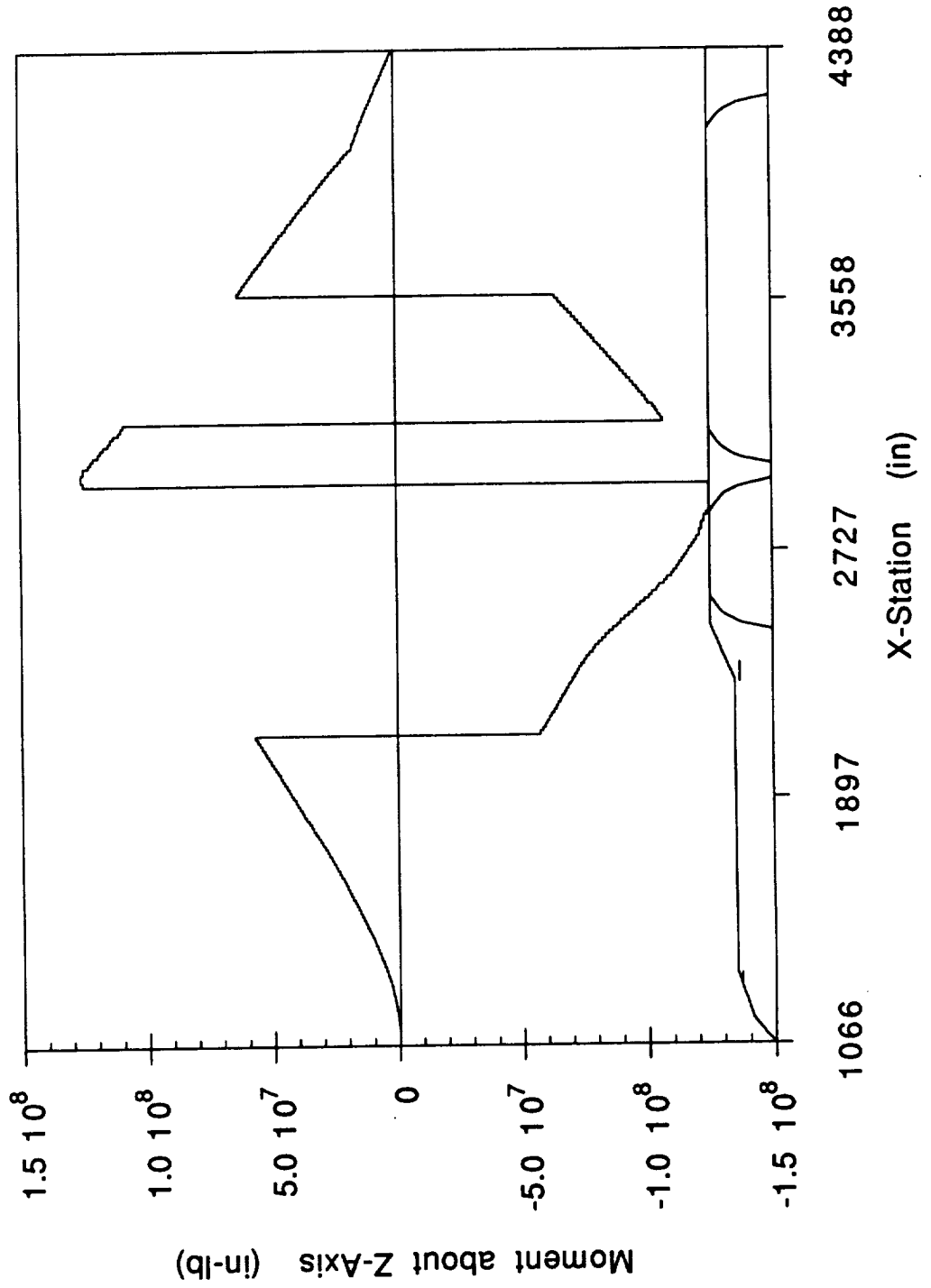

**NLS1 CORE MAX-G 1ST STAGE
NX vs X-STATION**

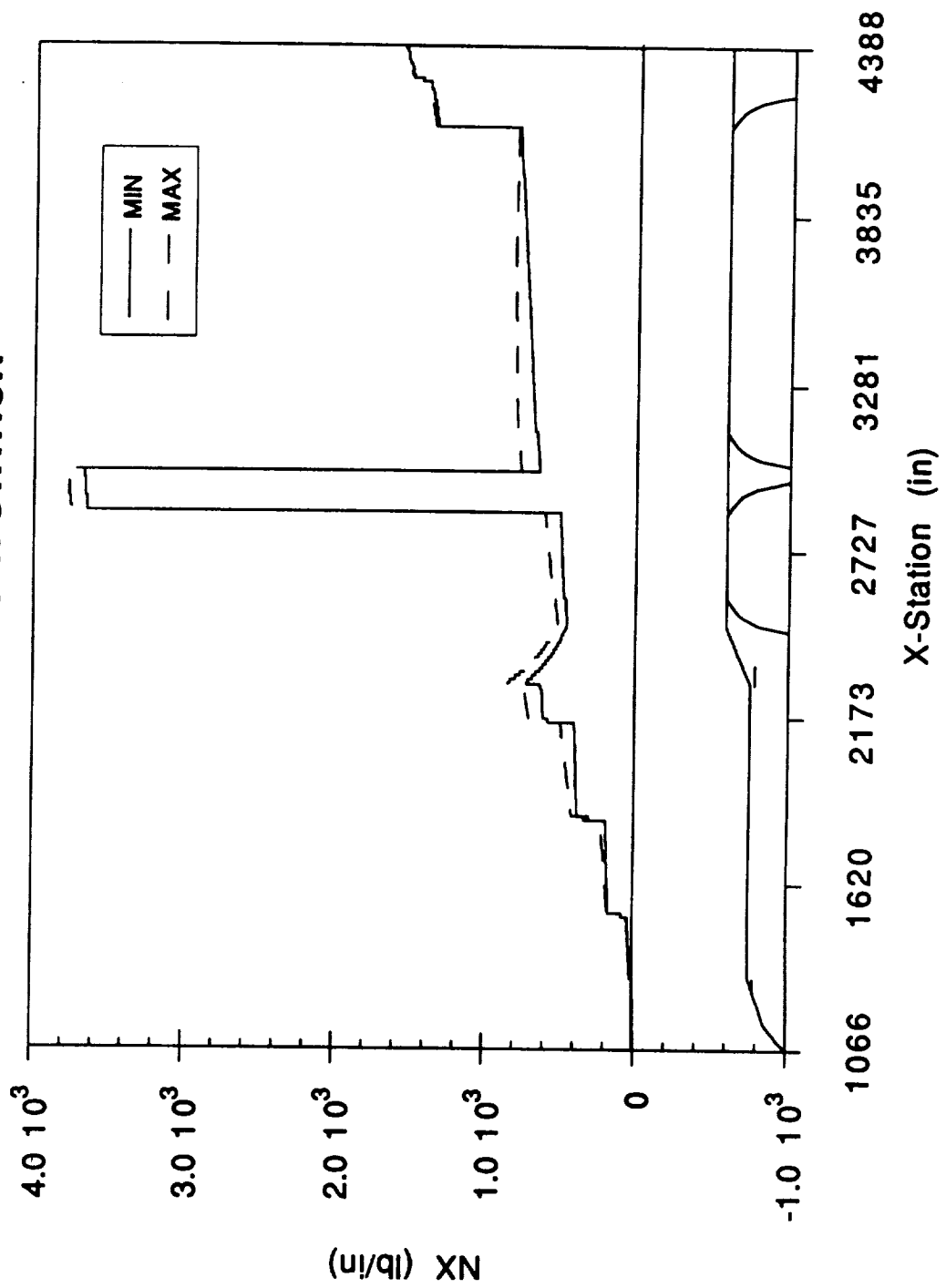

**NLS1 CORE MAX-G 1ST STAGE
NV vs X-STATION**

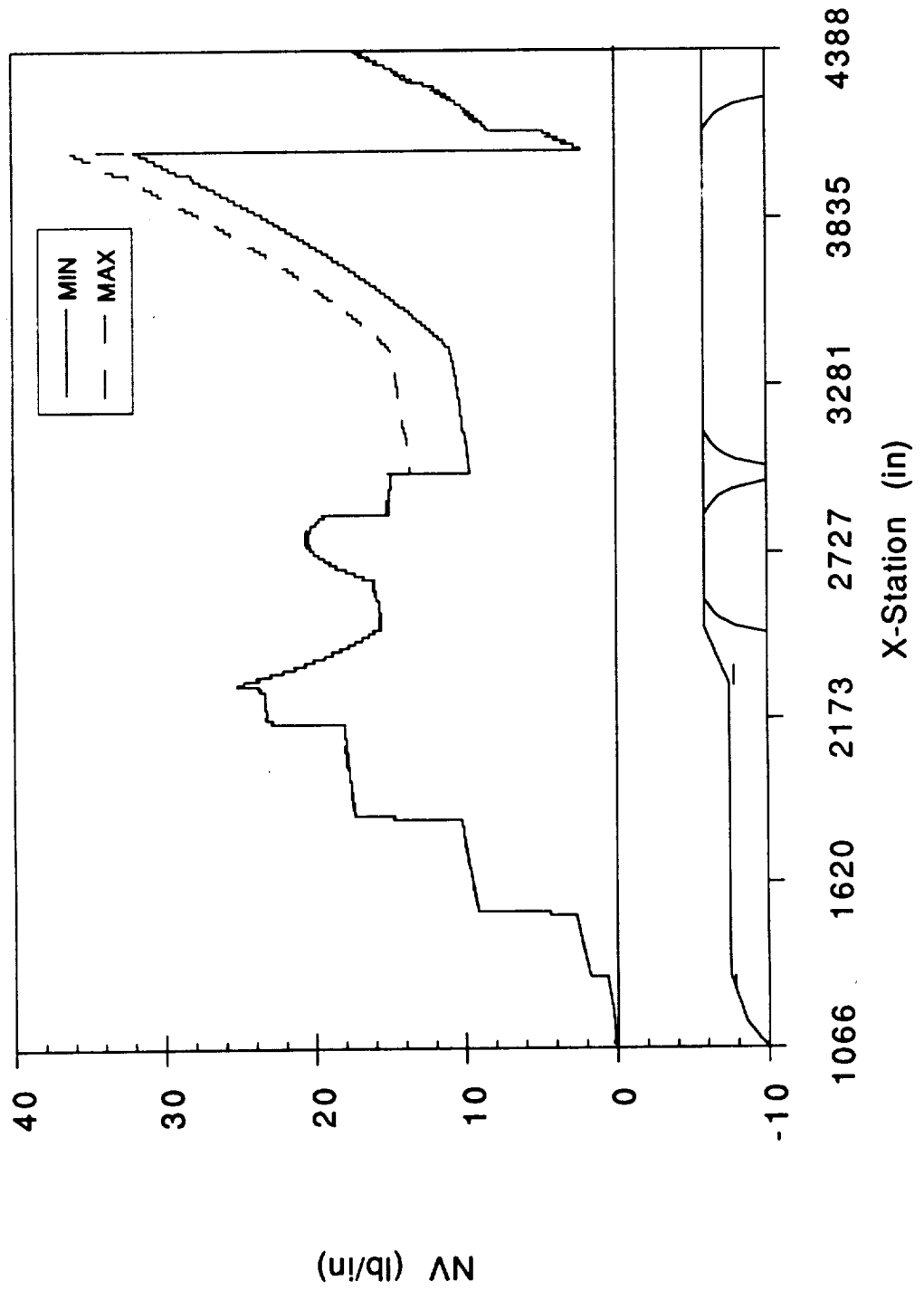

**NLS1 CORE - MAX G FIRST STAGE
AXIAL SHEAR vs X-STATION**

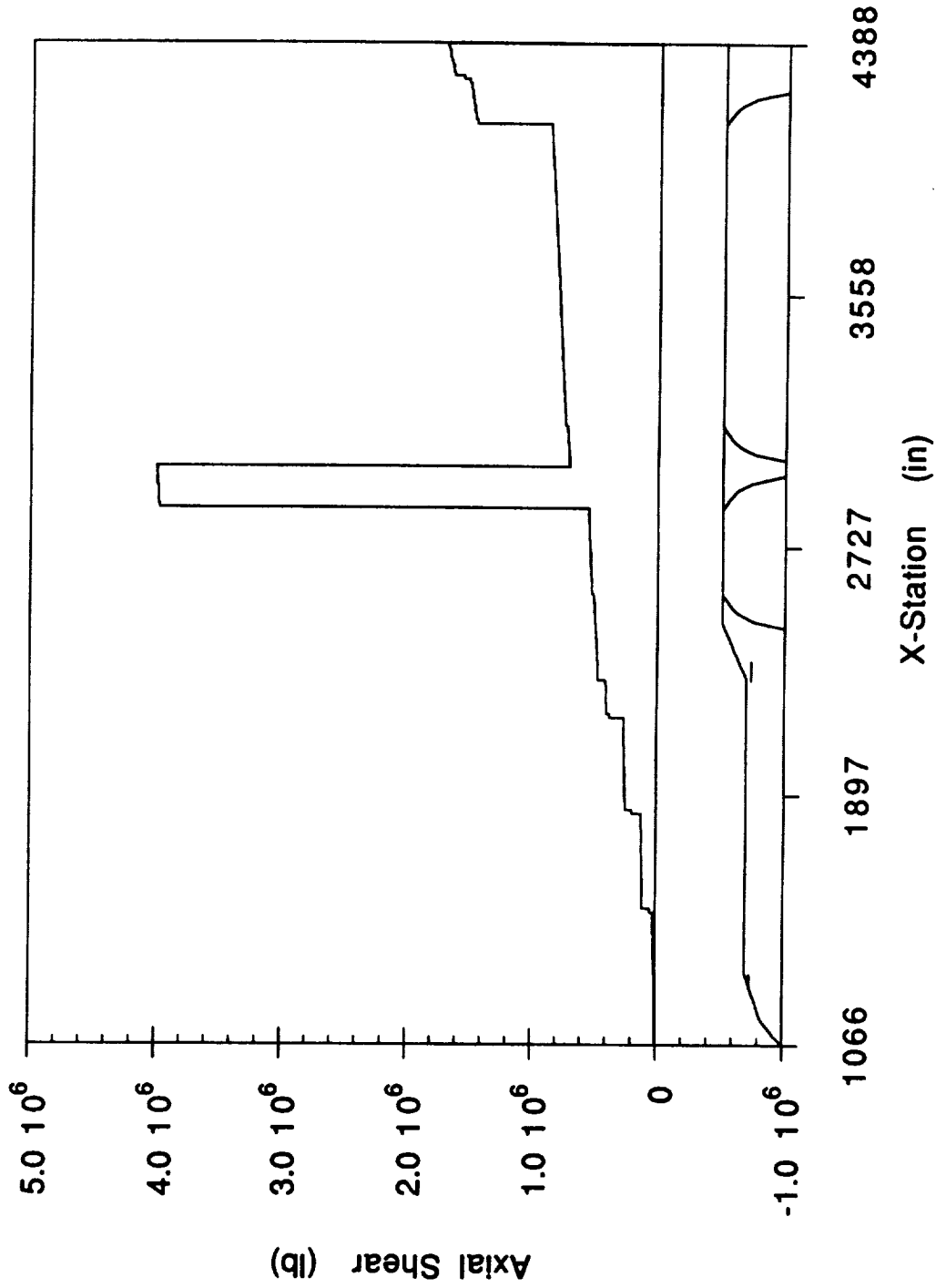

**NLS1 CORE - MAX G FIRST STAGE
Y-DIR SHEAR vs X-STATION**

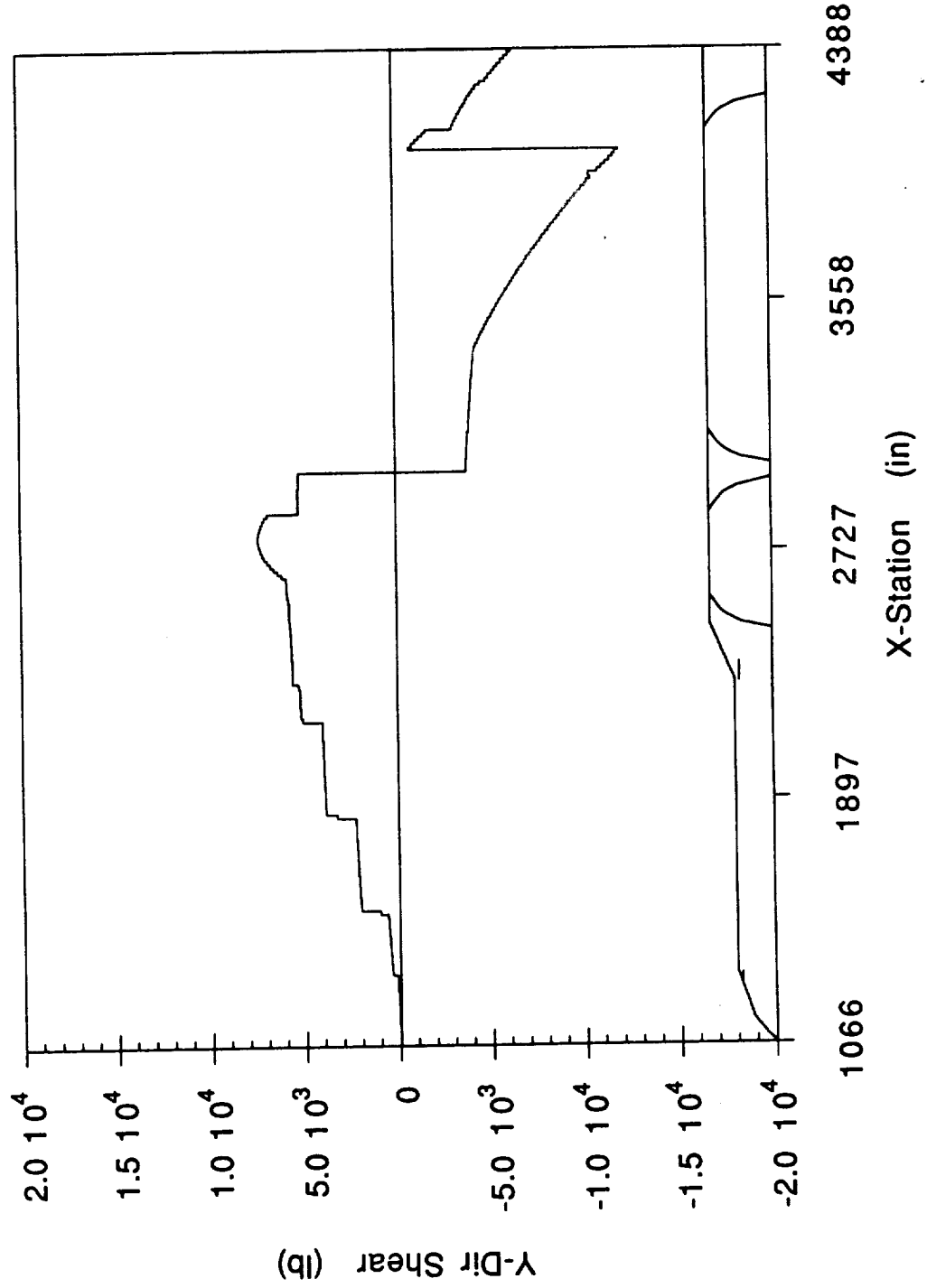

**NLS1 CORE - MAX G FIRST STAGE
Z-DIR SHEAR vs X-STATION**

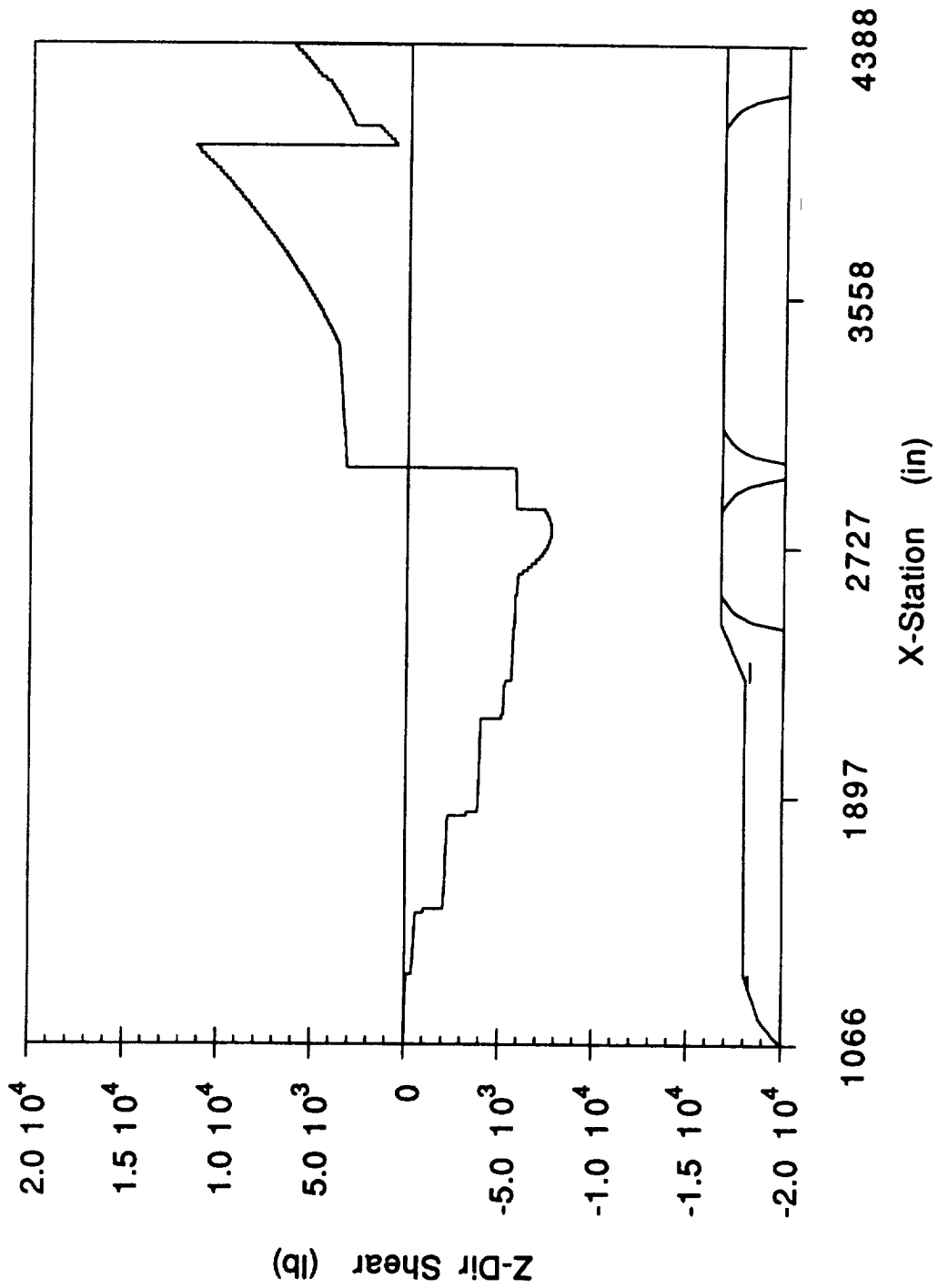

**NLS1 CORE - MAX G FIRST STAGE
Y-DIR MOMENT vs X-STATION**

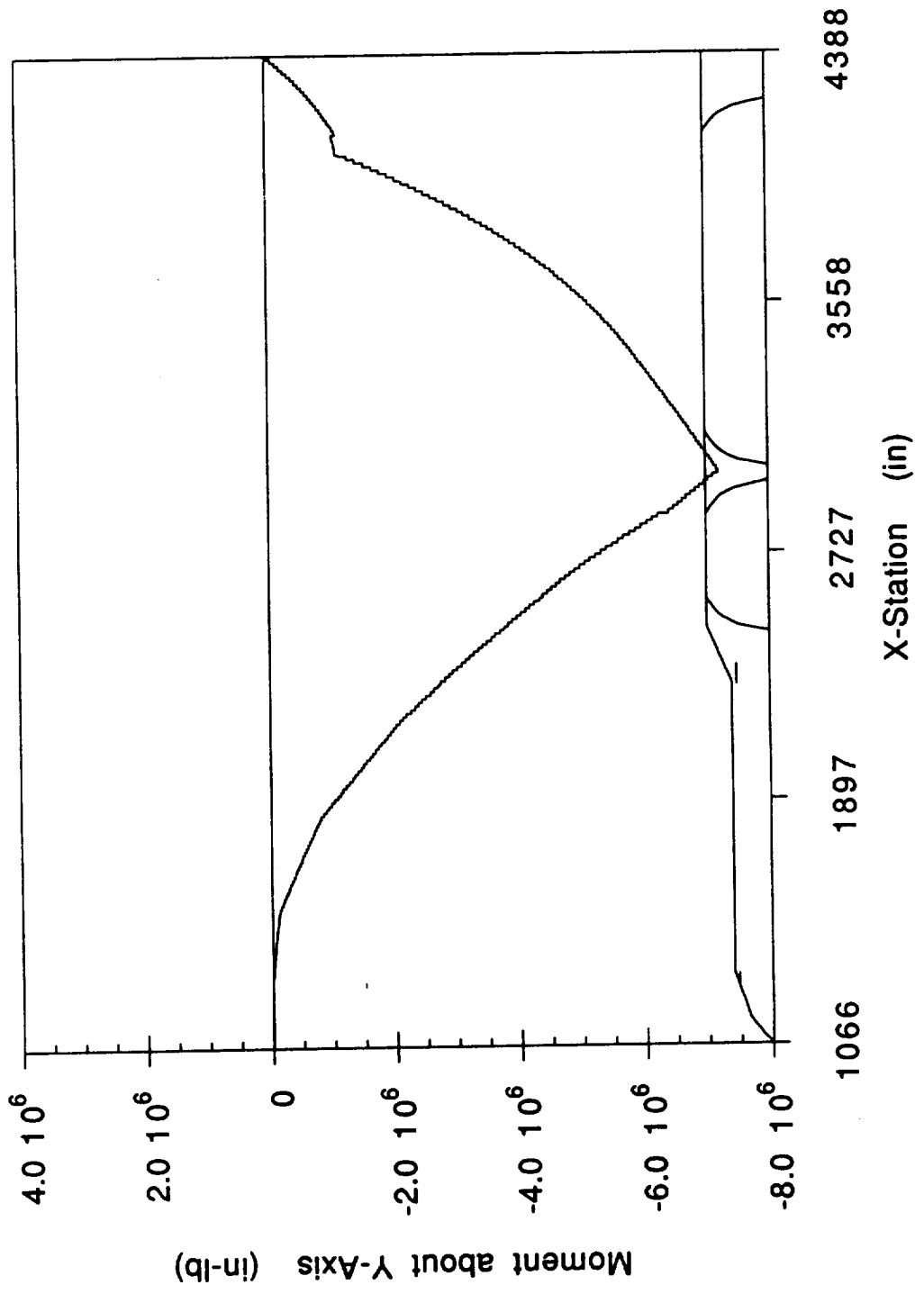

**NLS1 CORE - MAX G FIRST STAGE
Z-DIR MOMENT vs X-STATION**

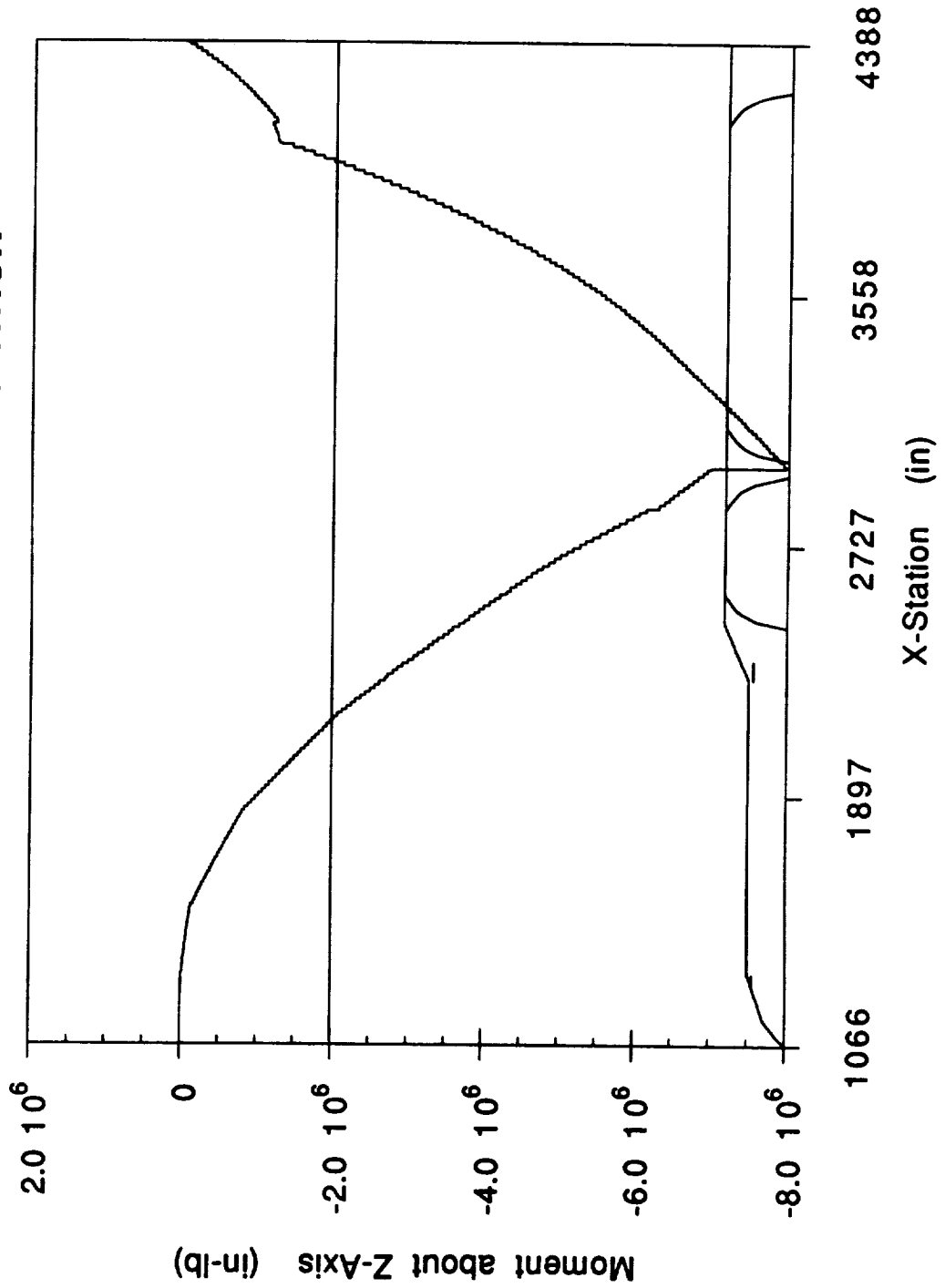

**NLS1 CORE MAX-G 2ND STAGE
NX vs X-STATION**

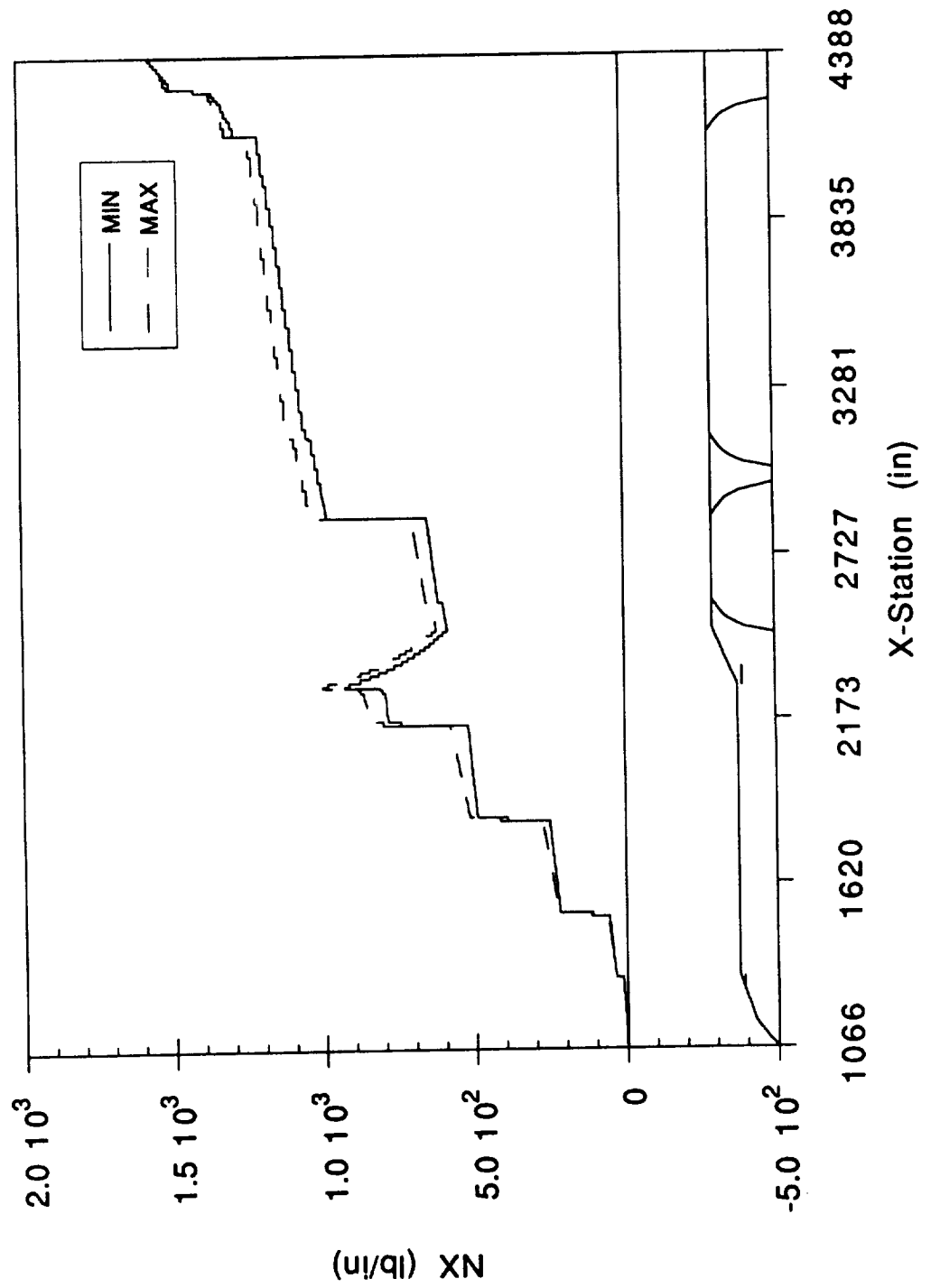

NLS1 CORE MAX-G 2ND STAGE NV vs X-STATION

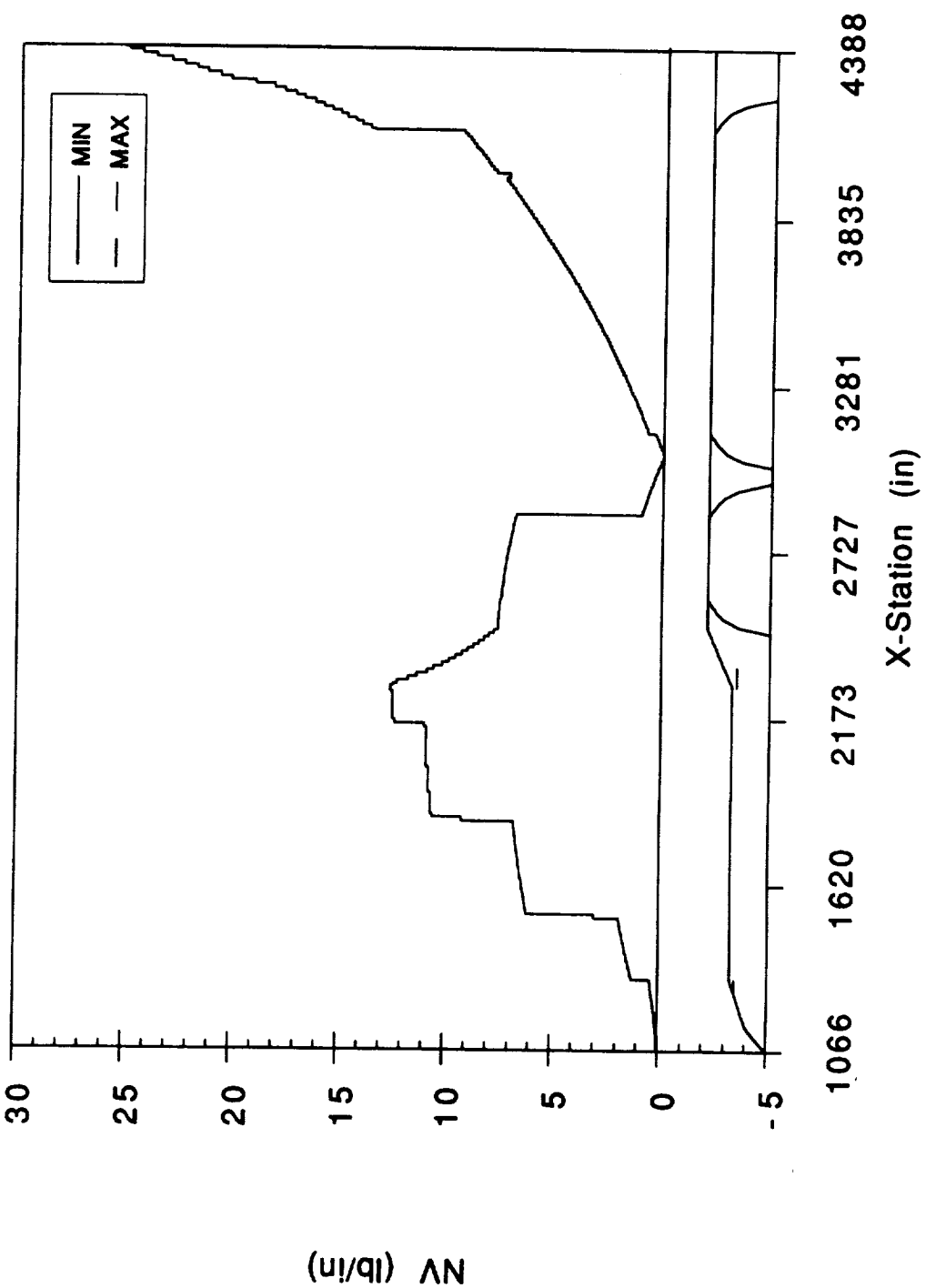

9-5

(((

**NLS1 CORE - MAX G SECOND STAGE
AXIAL SHEAR vs X-STATION**

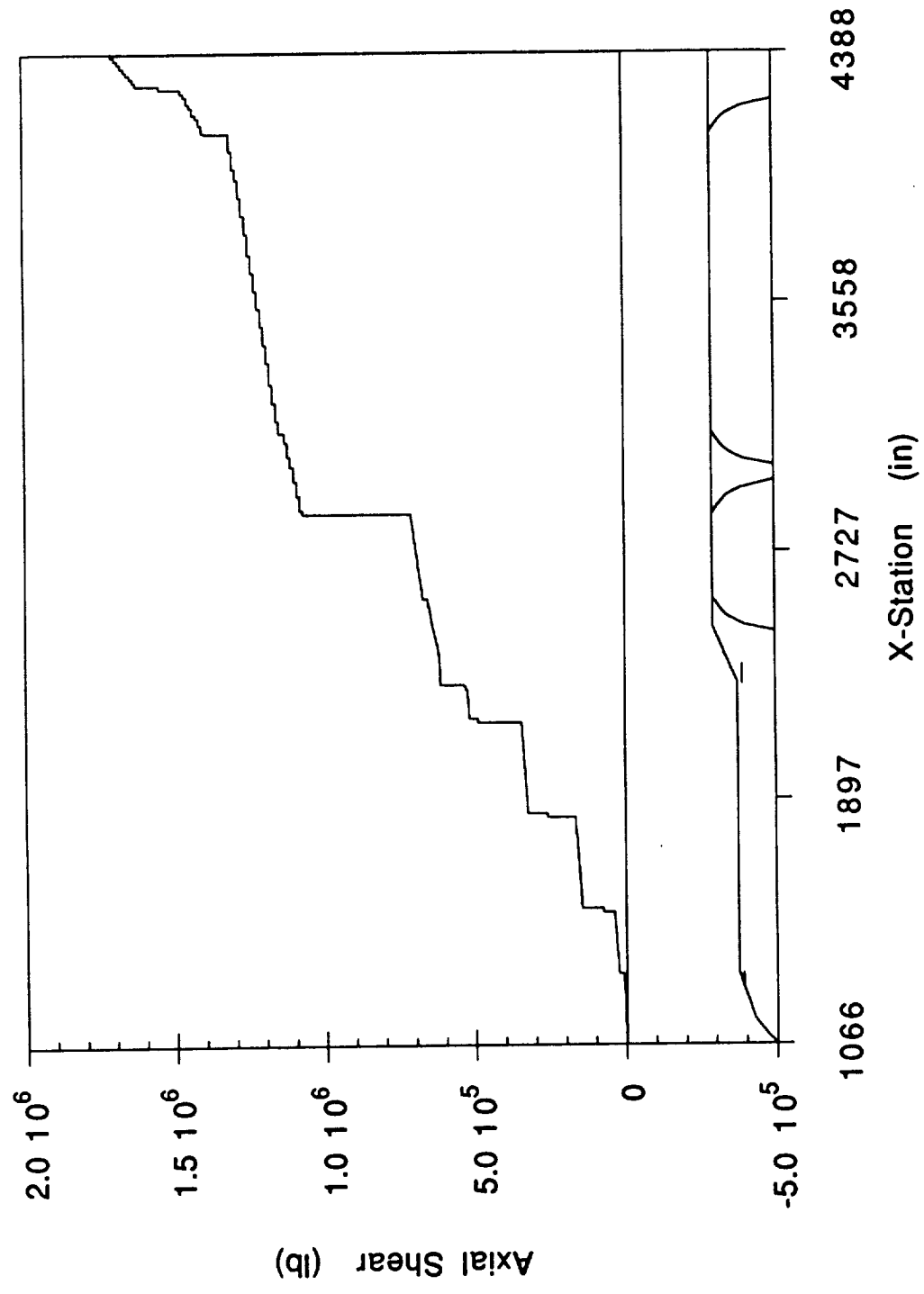

**NLS1 CORE - MAX G SECOND STAGE
Y-DIR SHEAR vs X-STATION**

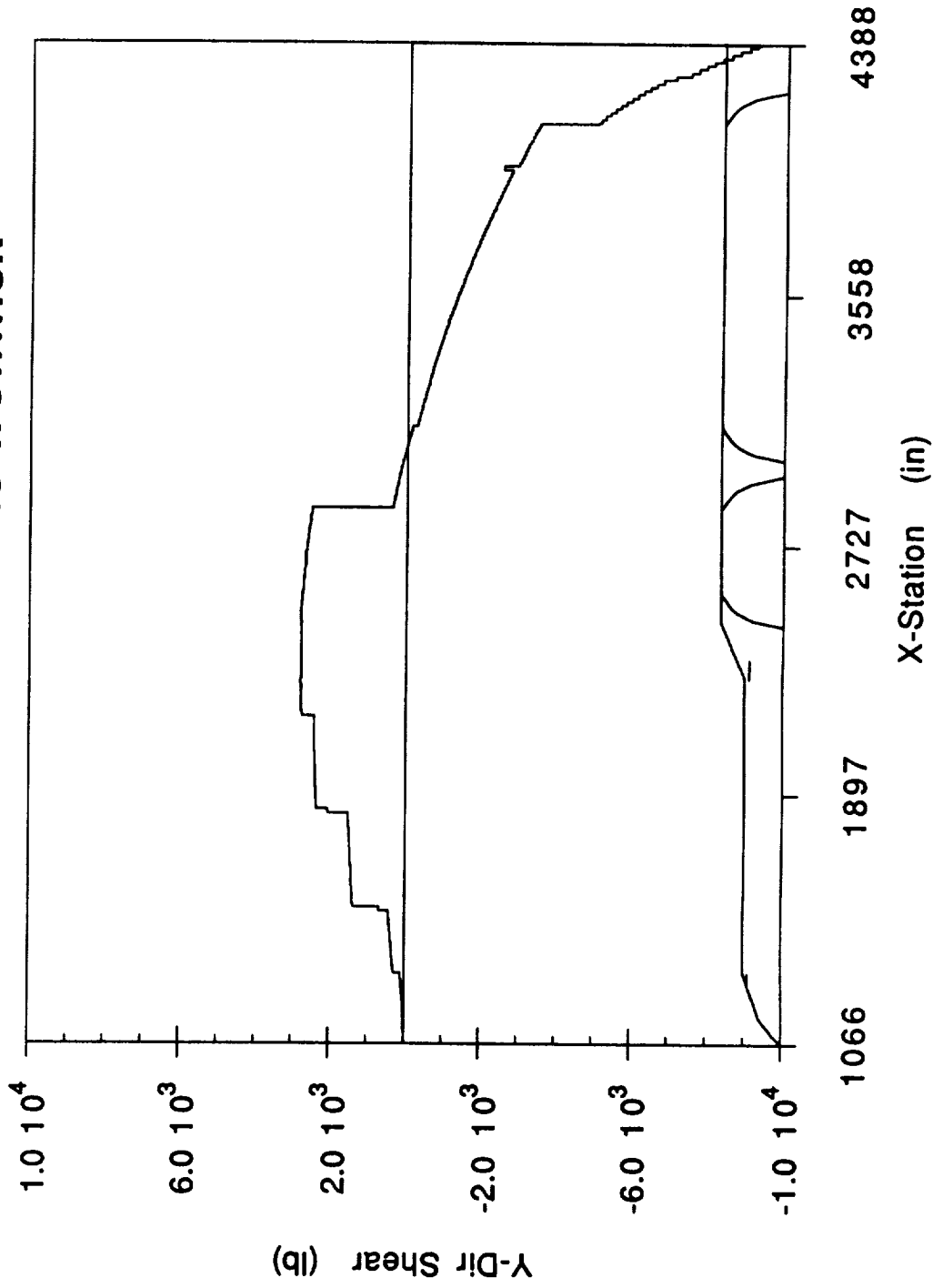

**NLS1 CORE - MAX G SECOND STAGE
Z-DIR SHEAR vs X-STATION**

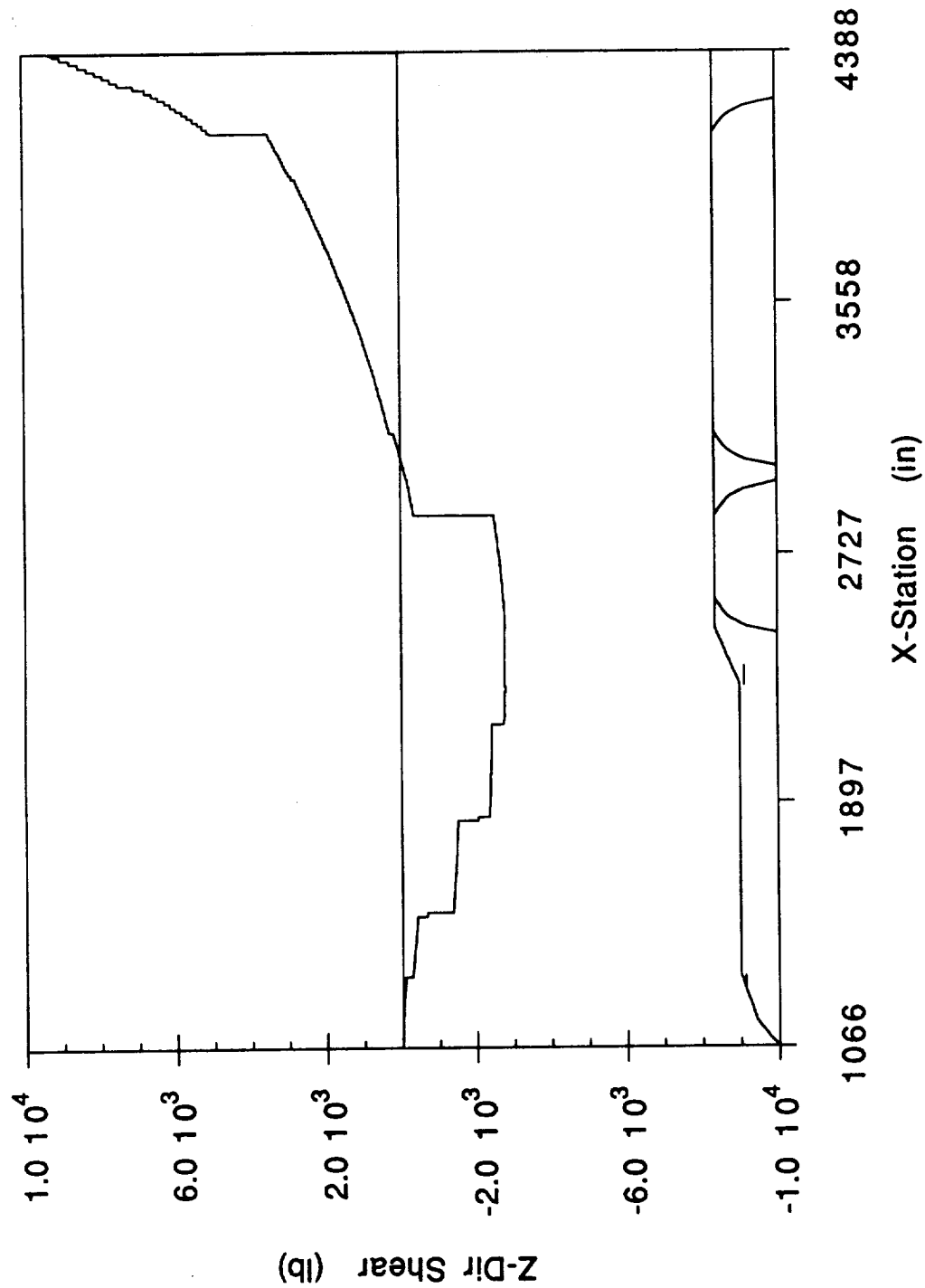

**NLS1 CORE - MAX G SECOND STAGE
Y-DIR MOMENT vs X-STATION**

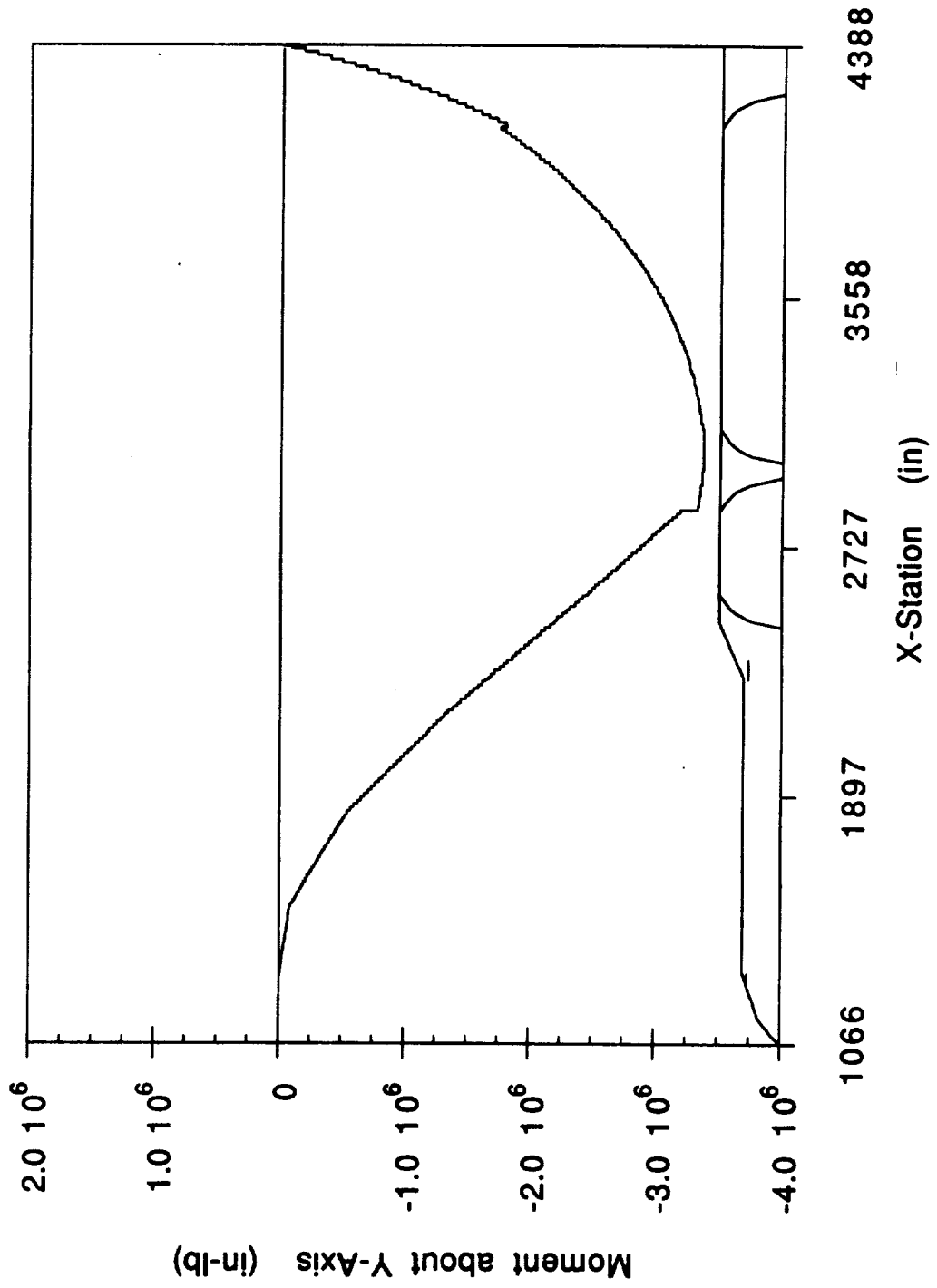

**NLS1 CORE - MAX G SECOND STAGE
Z-DIR MOMENT vs X-STATION**

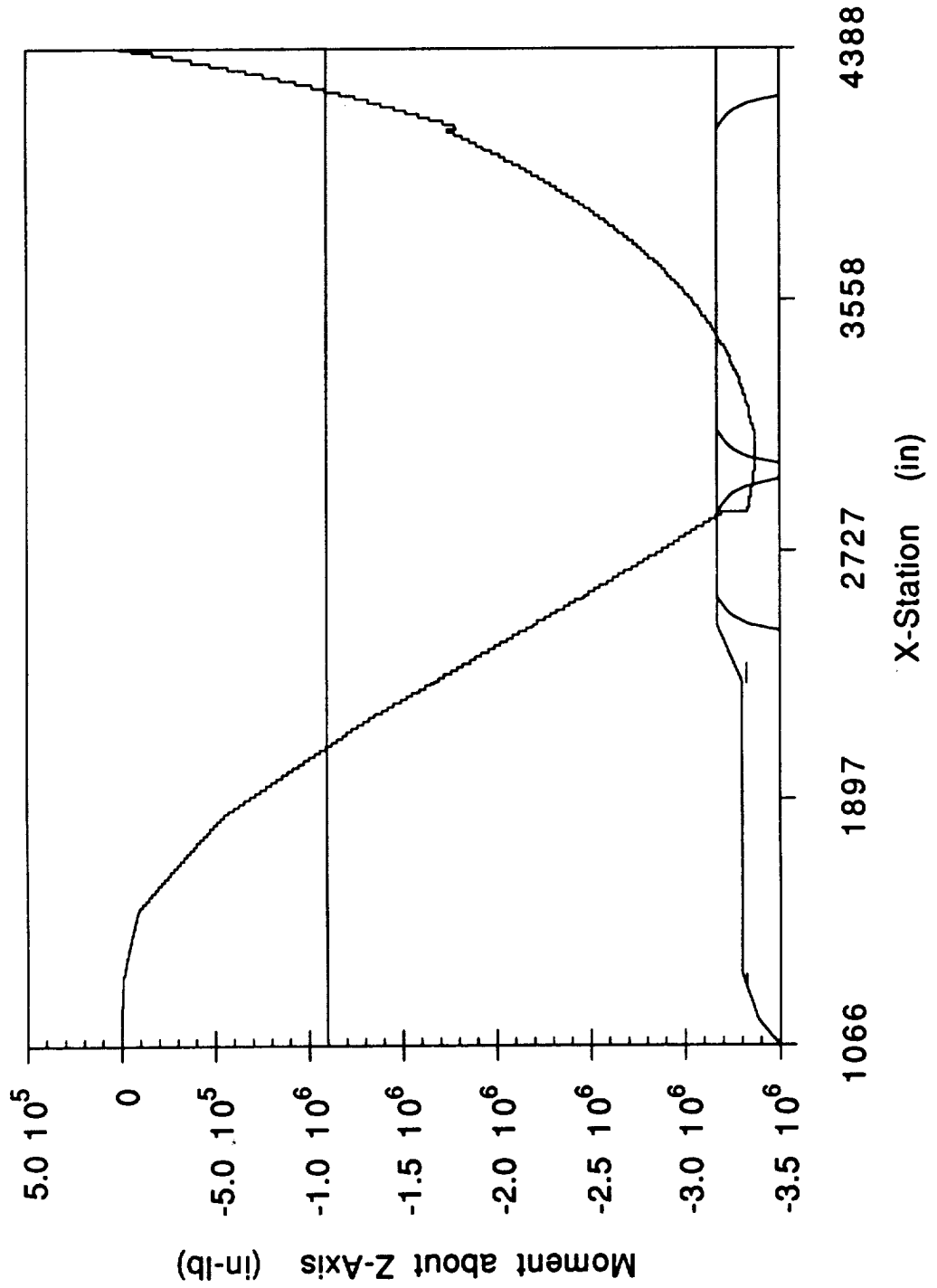

NLS2 CORE ASCENT OVERALL MAXIMUM P EQUIVALENT vs X-STATION

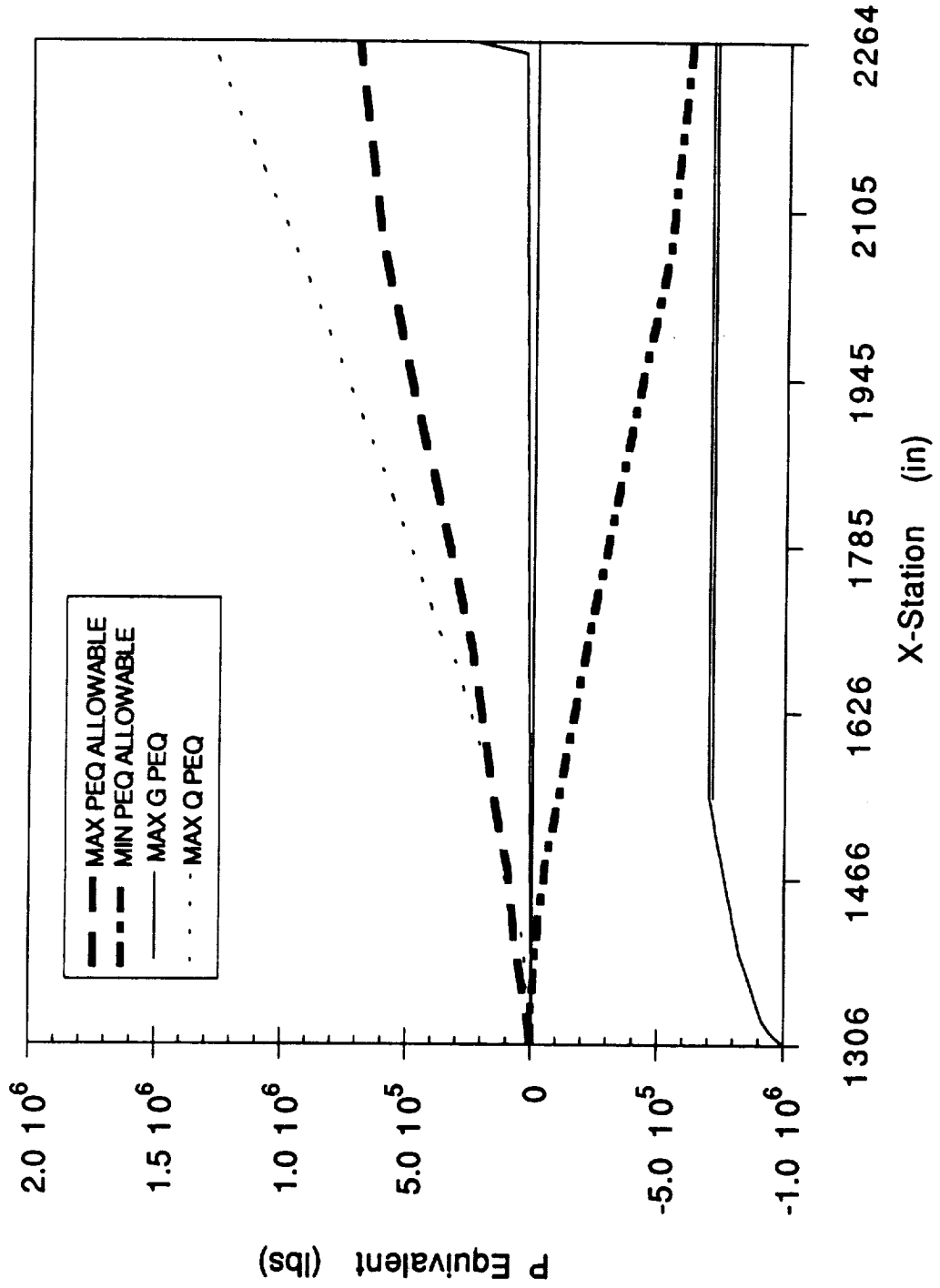

((

**NLS2 CORE ASCENT
OVERALL MAXIMUM V EQUIVALENT vs X-STATION**

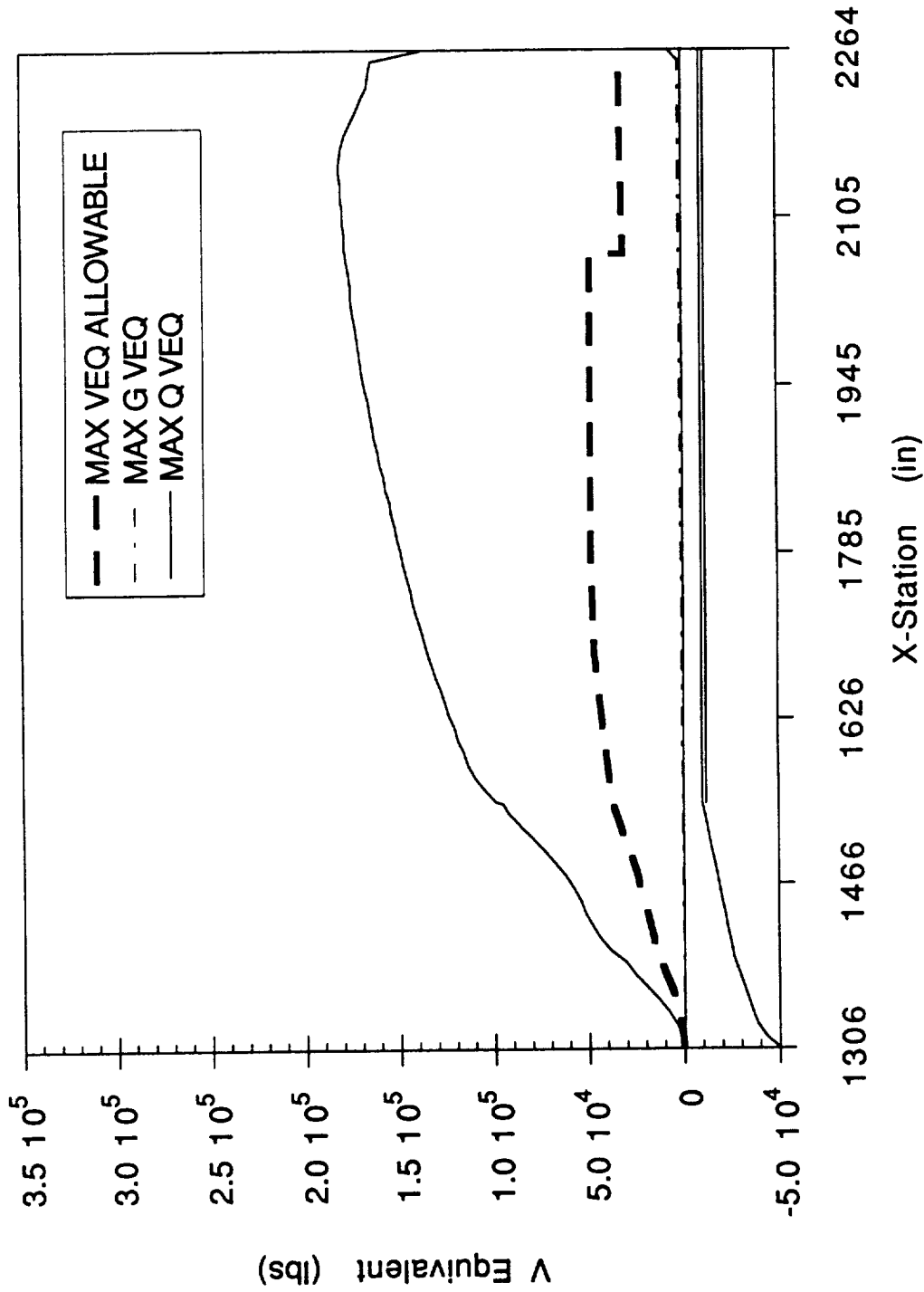

NLS2 CORE ASCENT ENGINE OUT OVERALL MAXIMUM P EQUIVALENT vs X-STATION

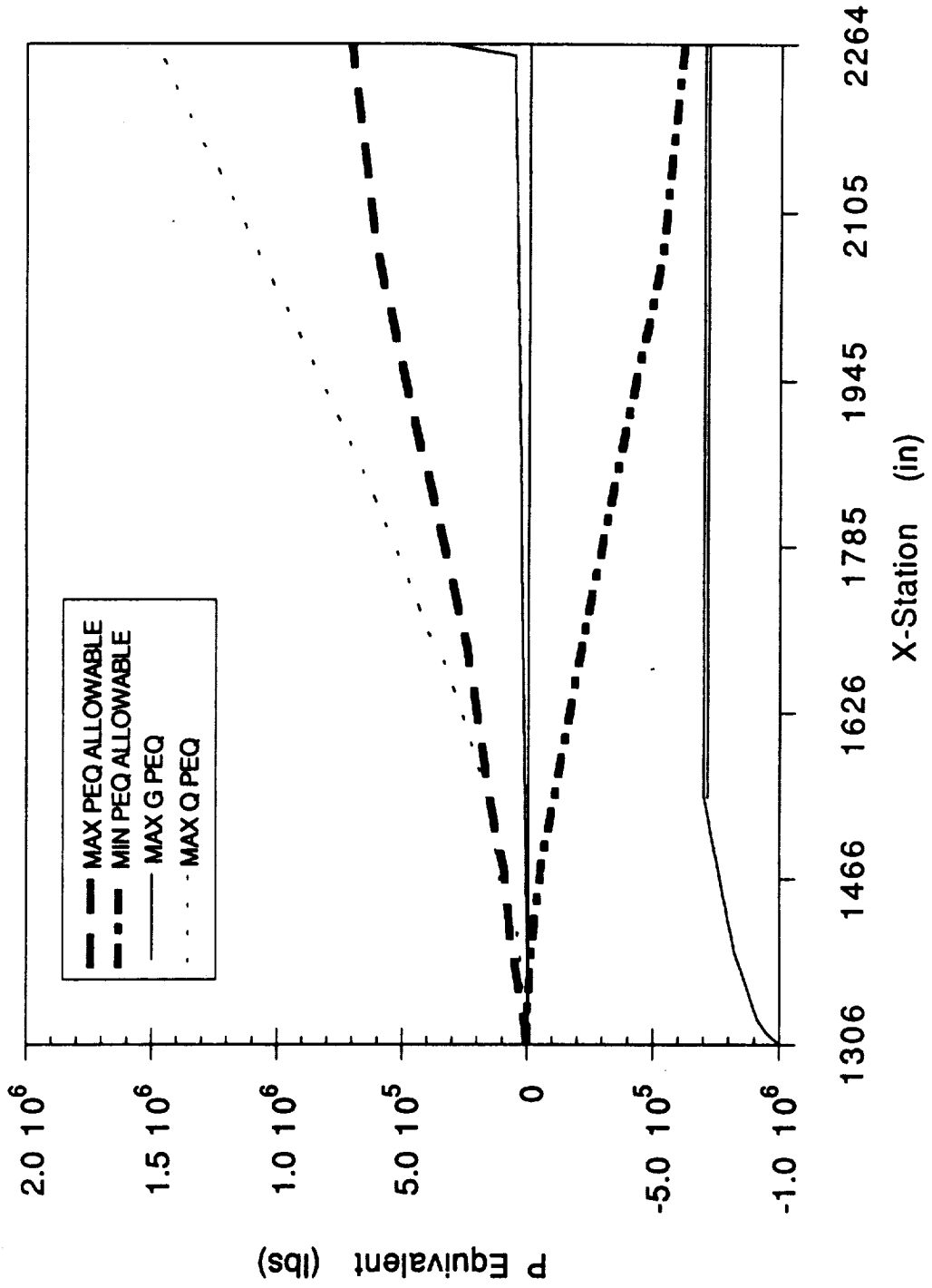

((

**NLS2 CORE ASCENT ENGINE OUT
OVERALL MAXIMUM V EQUIVALENT vs X-STATION**

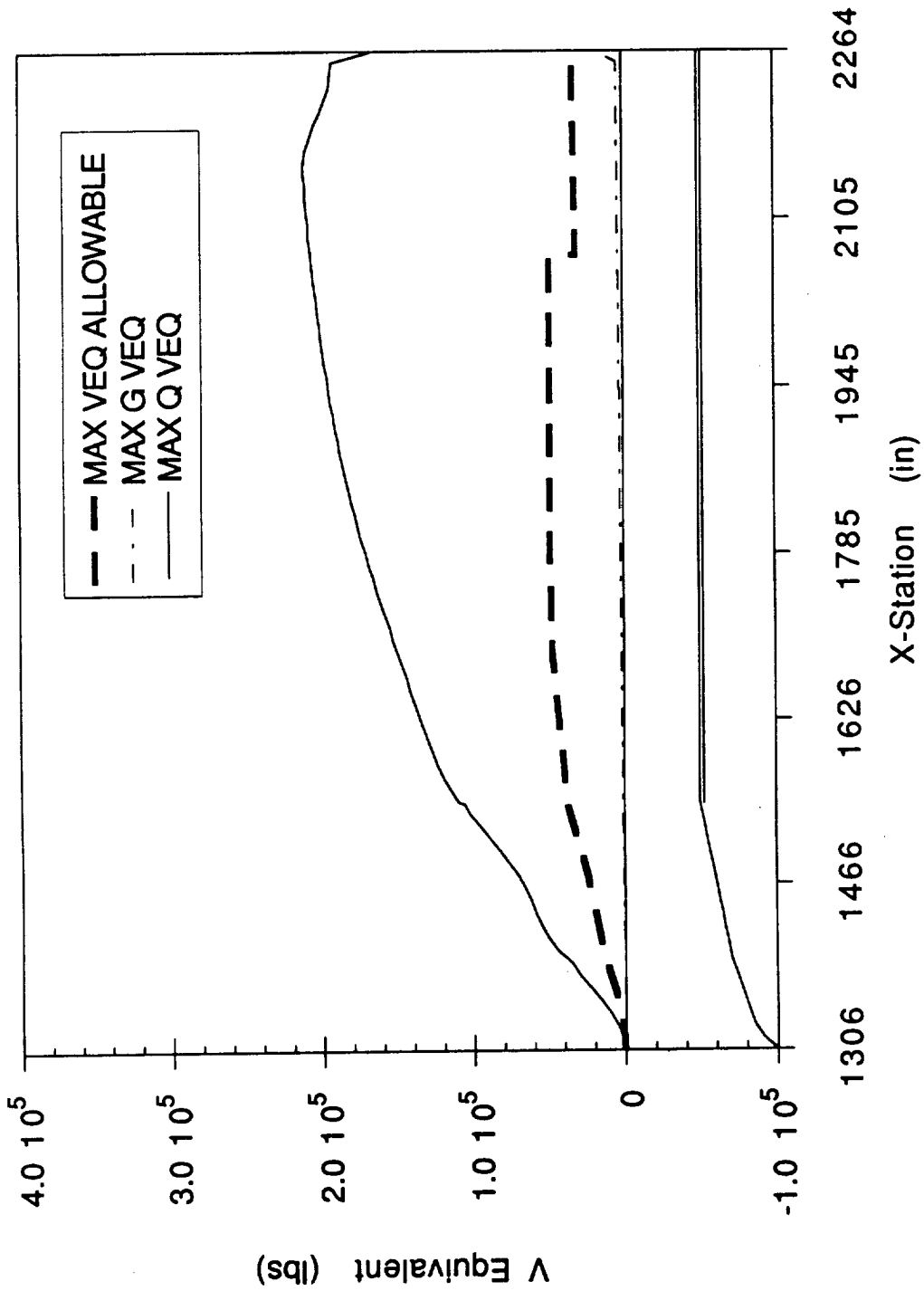

**NLS2 CORE - ASCENT
OVERALL MAXIMUM NX**

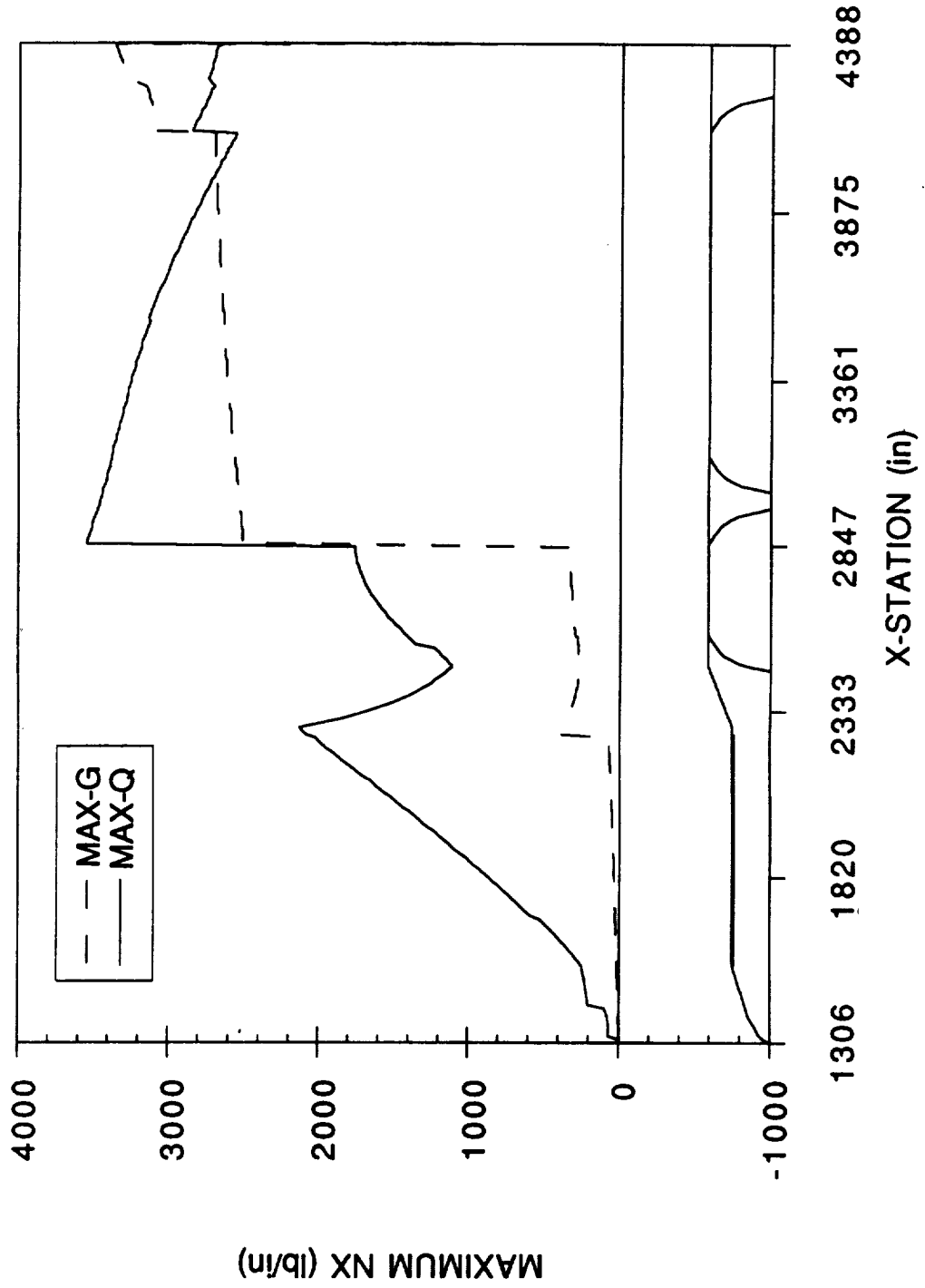

**NLS2 CORE - ASCENT
OVERALL MAXIMUM NV**

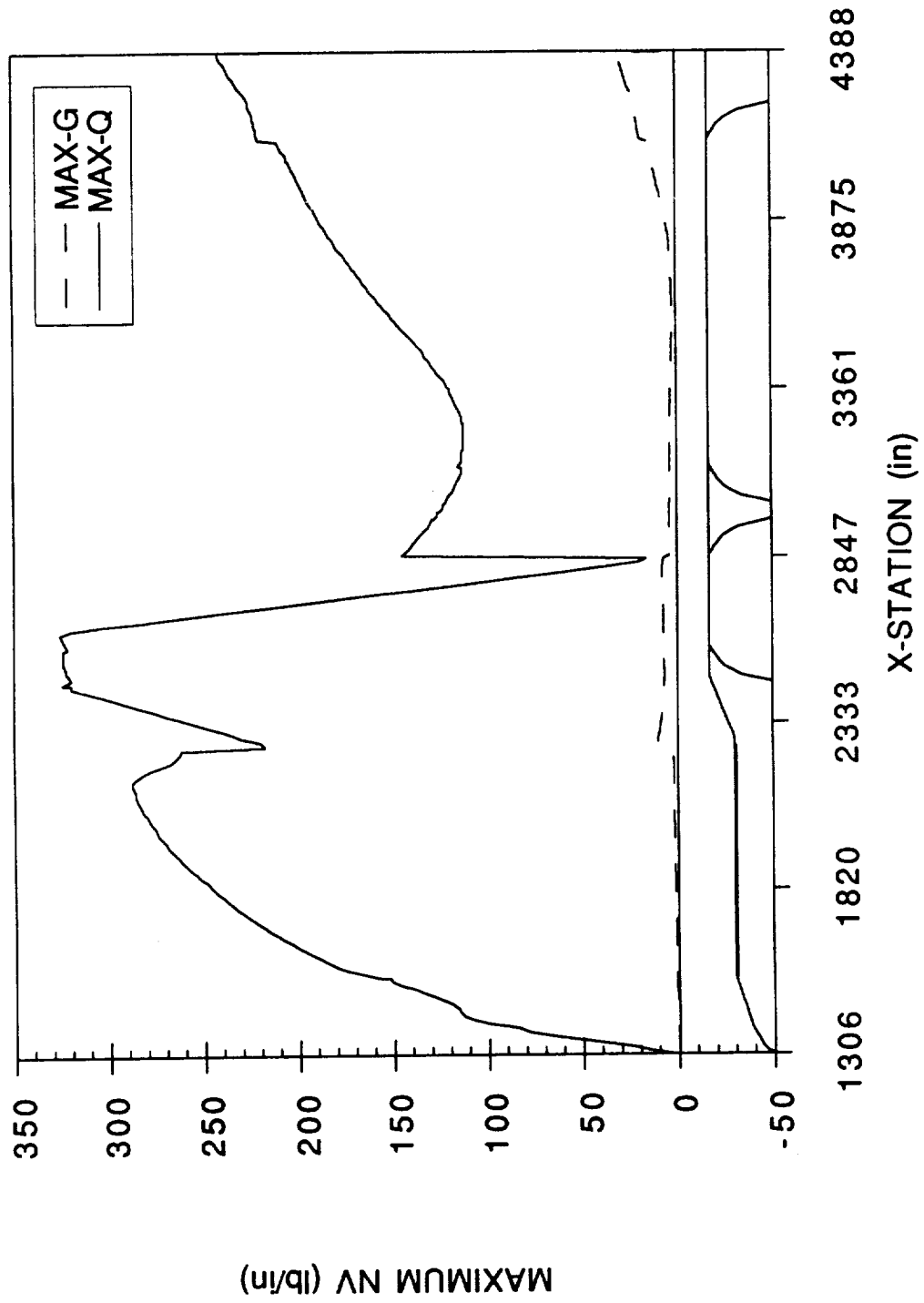

**NLS2 CORE - ASCENT
OVERALL MAXIMUM P EQUIVALENT**

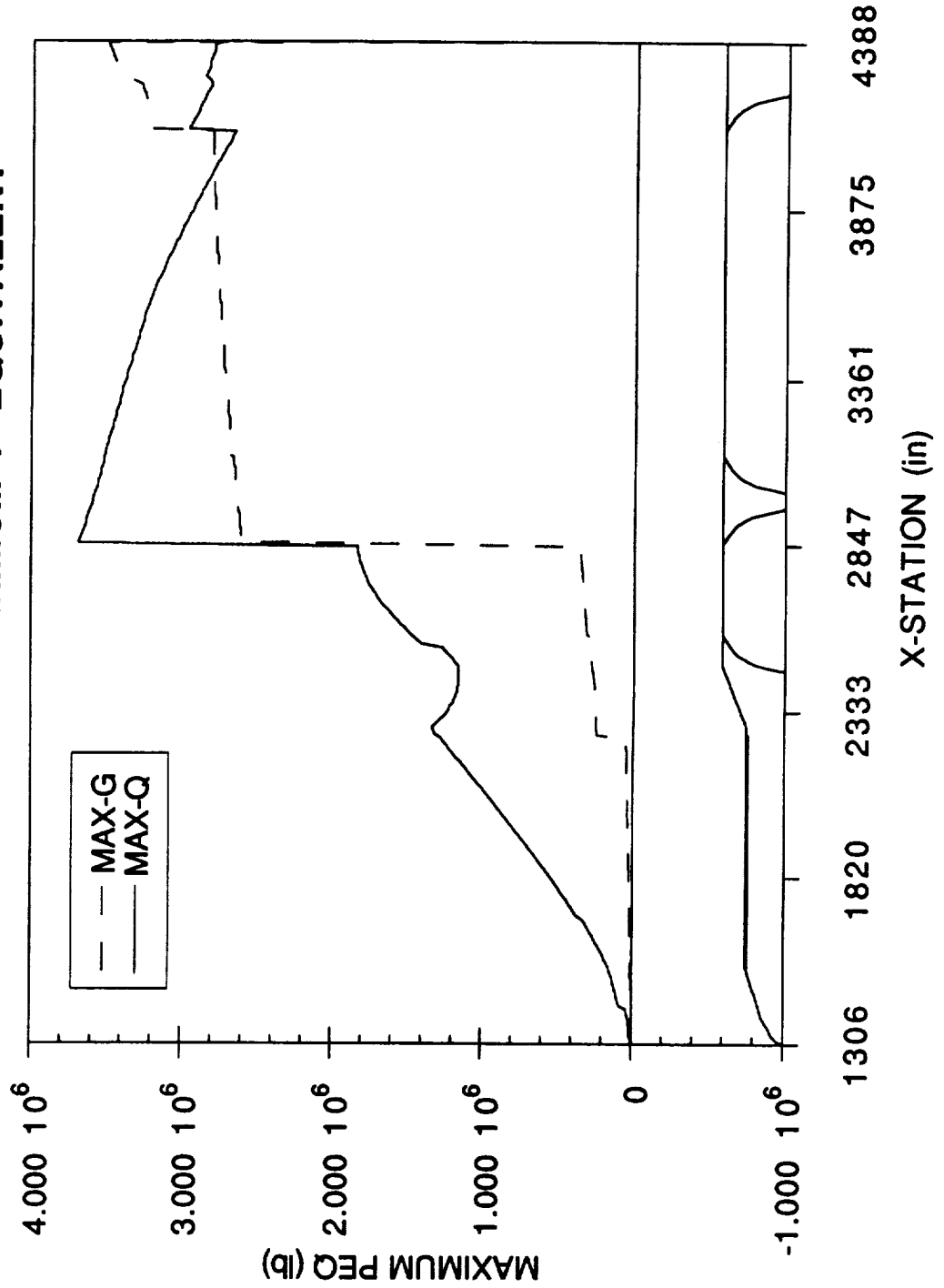

**NLS2 CORE - ASCENT
OVERALL MAXIMUM V EQUIVALENT**

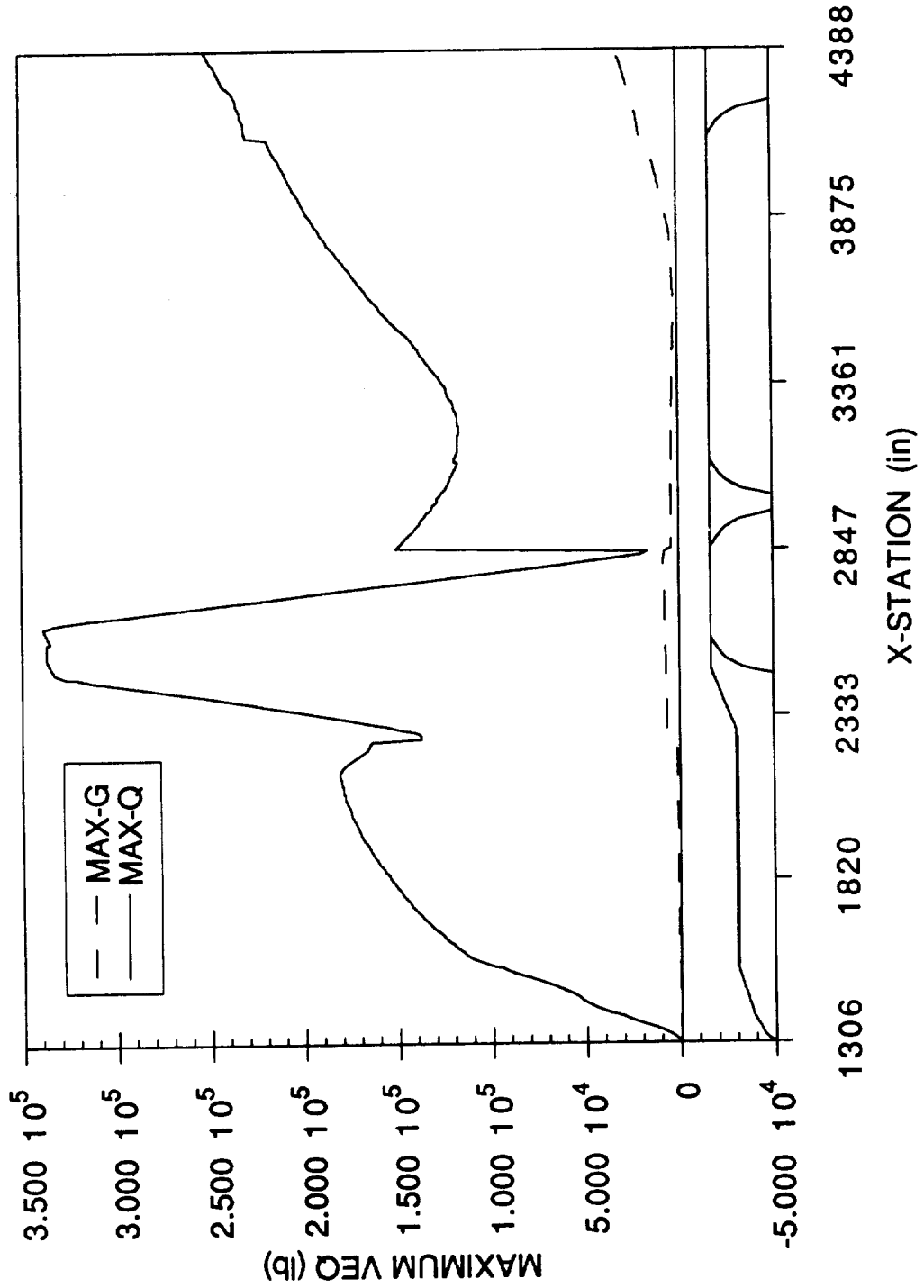

**NLS2 CORE - ASCENT
OVERALL MAXIMUM AXIAL SHEAR**

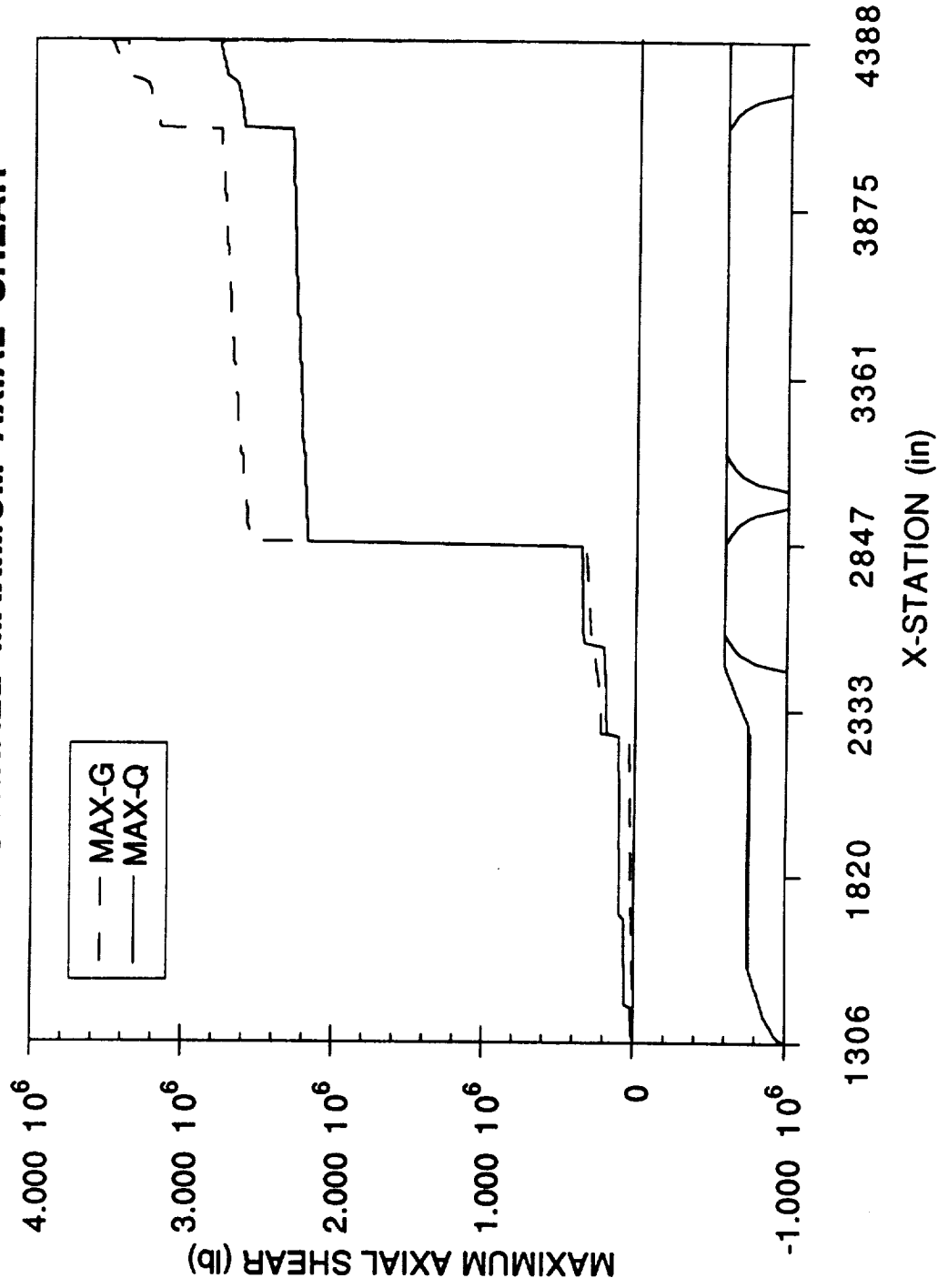

NLS2 CORE - ASCENT
OVERALL MAXIMUM SHEAR - Y DIRECTION

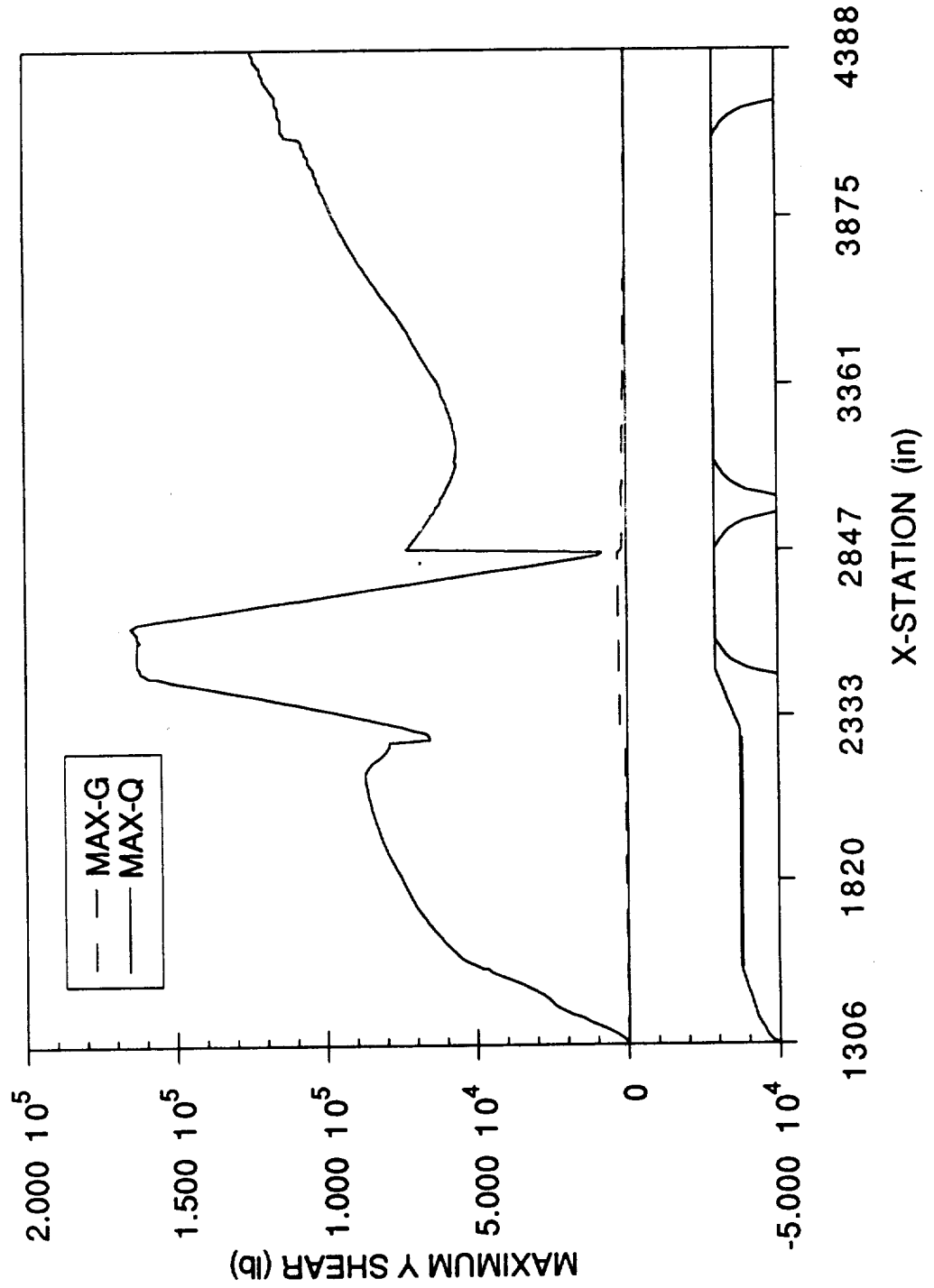

**NLS2 CORE - ASCENT
OVERALL MAXIMUM SHEAR - Z DIRECTION**

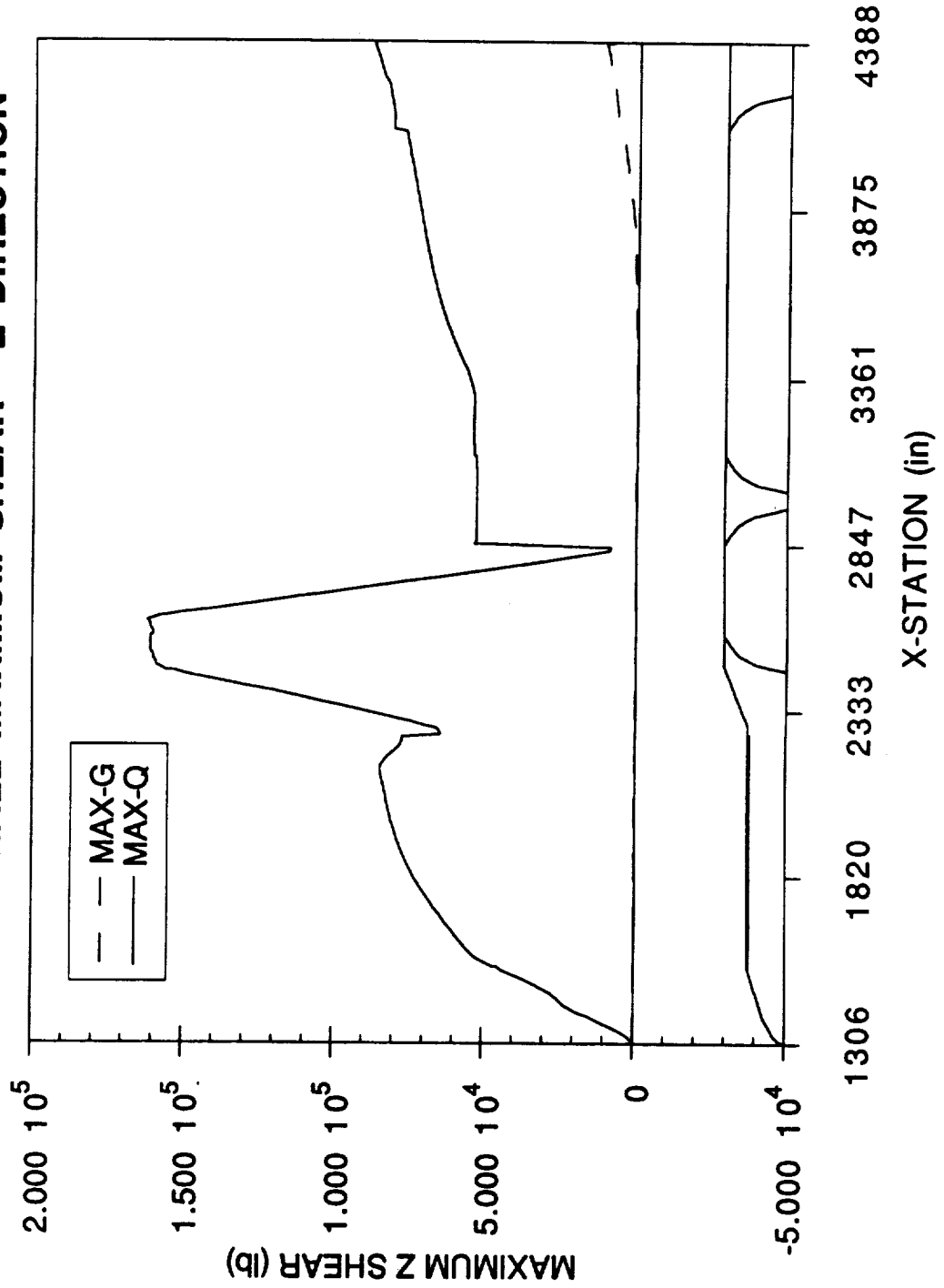

**NLS2 CORE - ASCENT
OVERALL MAXIMUM MOMENT - Y DIRECTION**

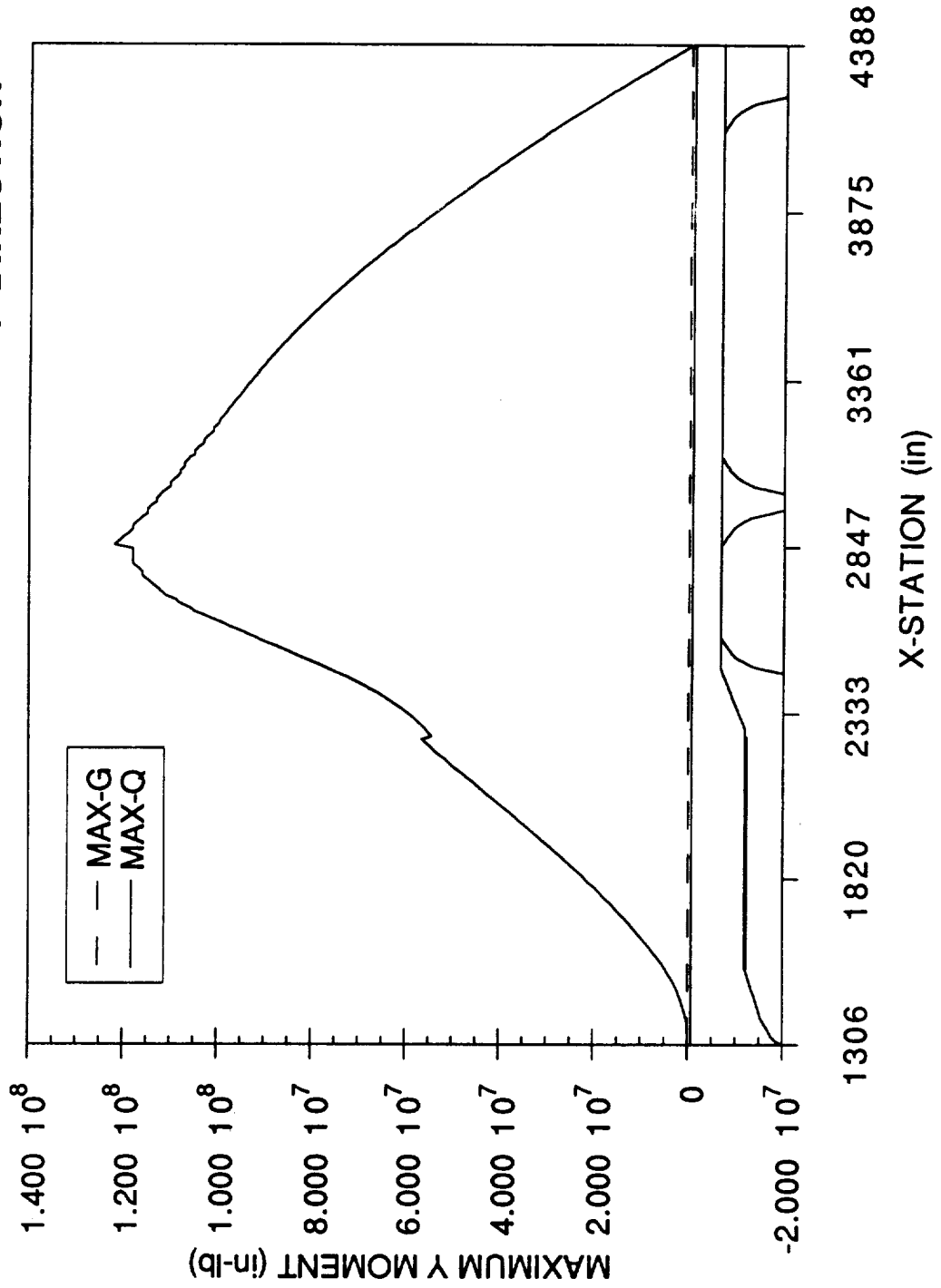

**NLS2 CORE - ASCENT
OVERALL MAXIMUM MOMENT - Z DIRECTION**

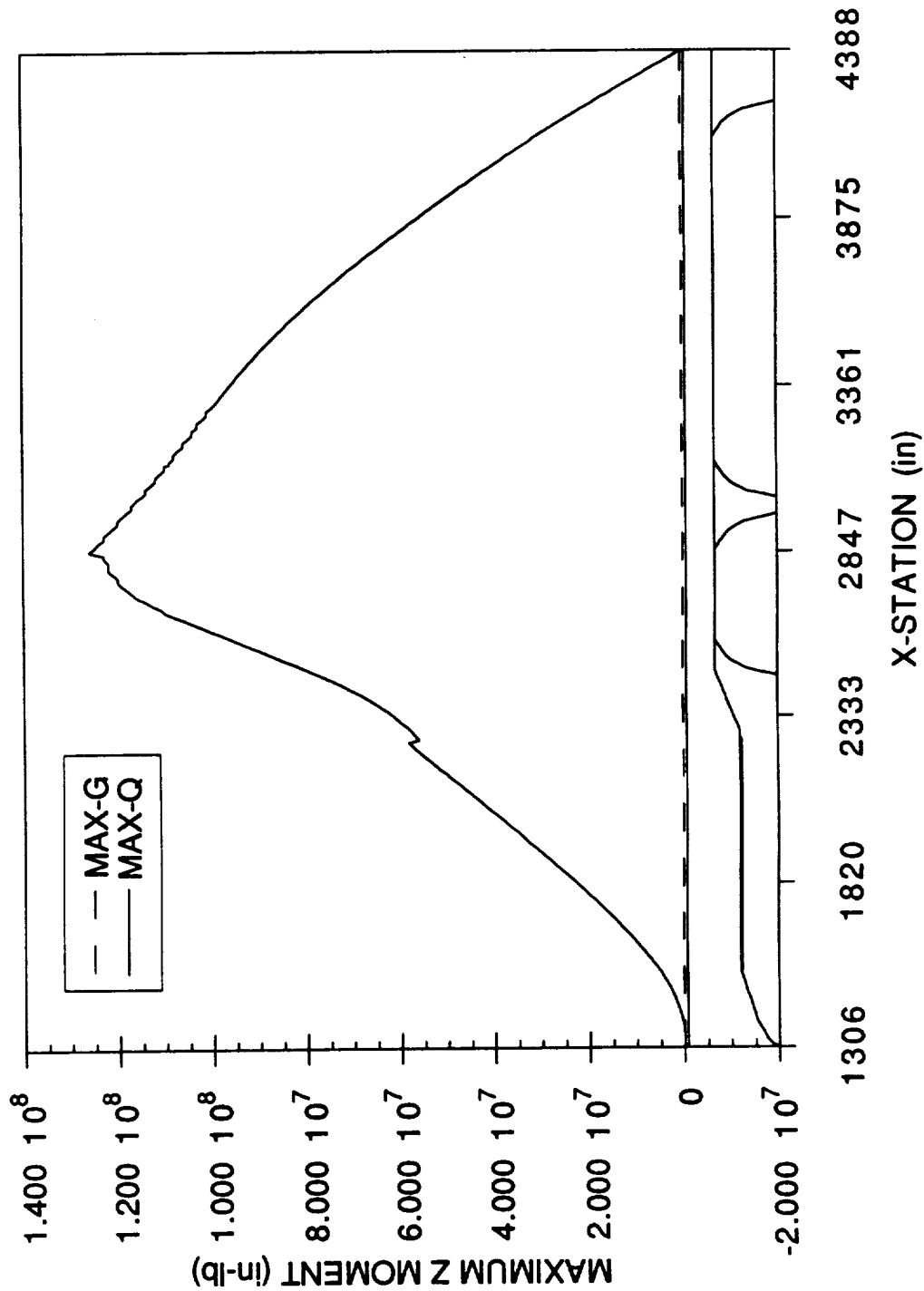

**NLS2 CORE - 3 km
NX vs X-STATION**

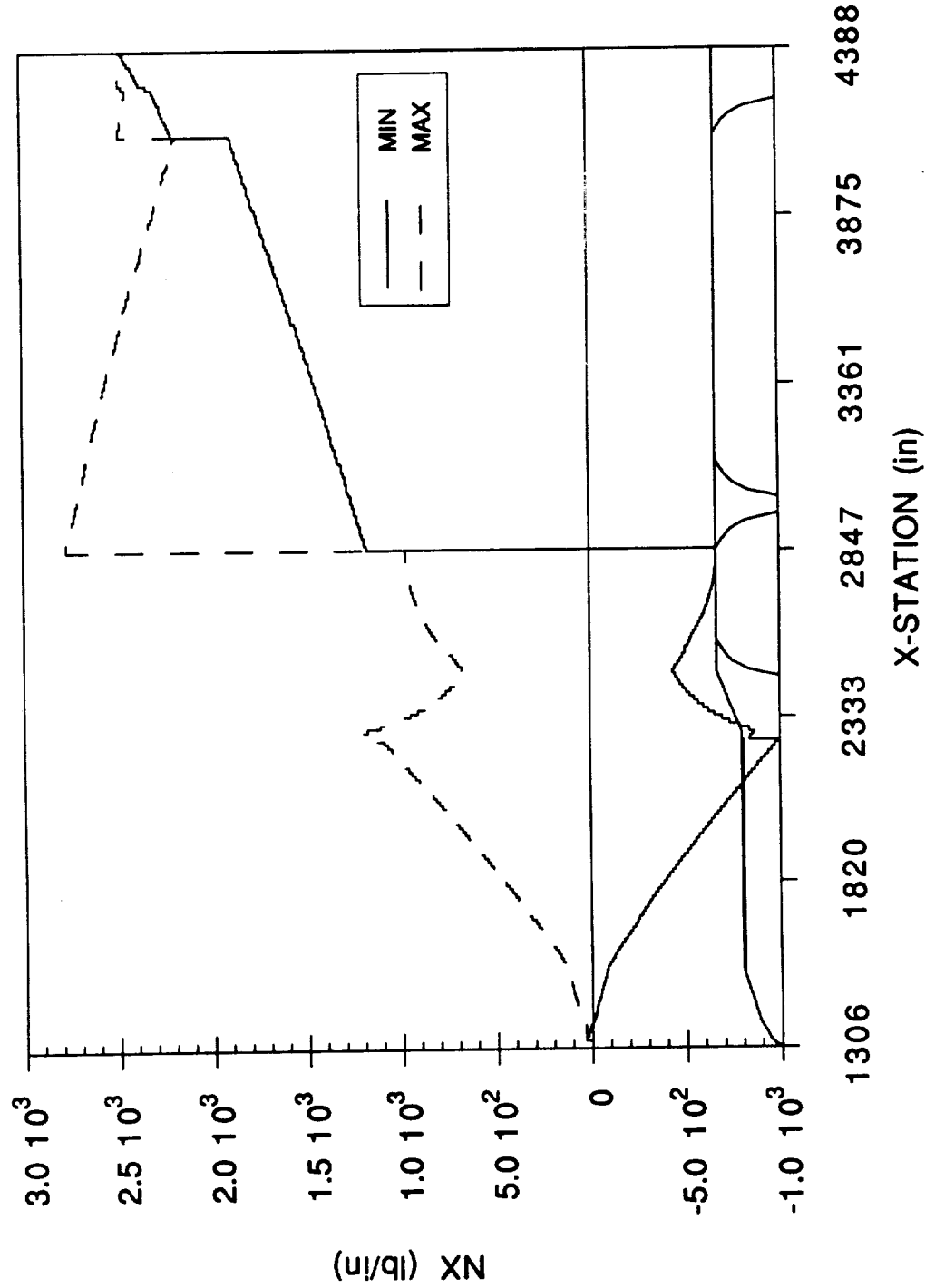

**NLS2 CORE - 3 km
NV vs X-STATION**

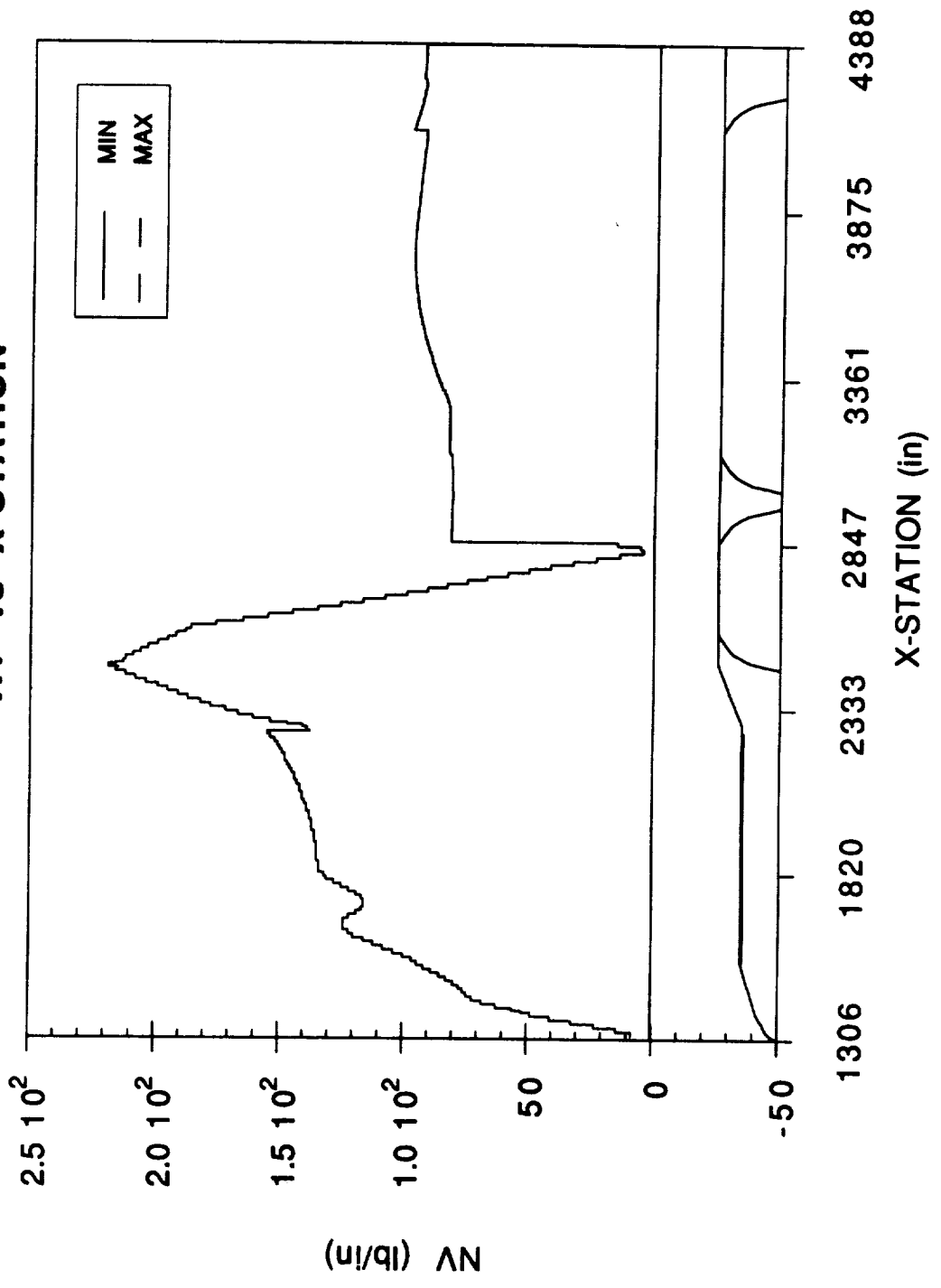

**NLS2 CORE - 3 km
AXIAL SHEAR vs X-STATION**

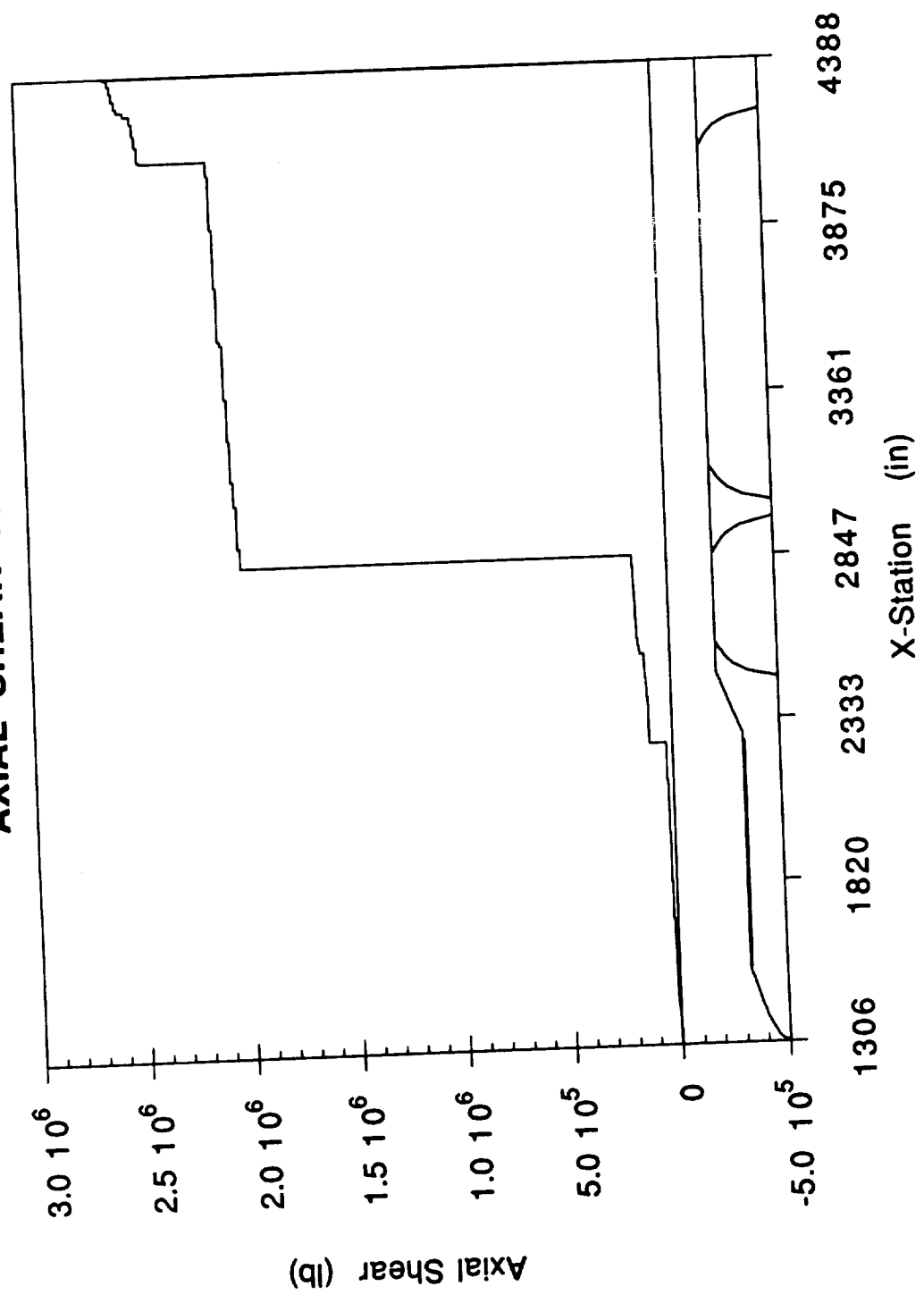

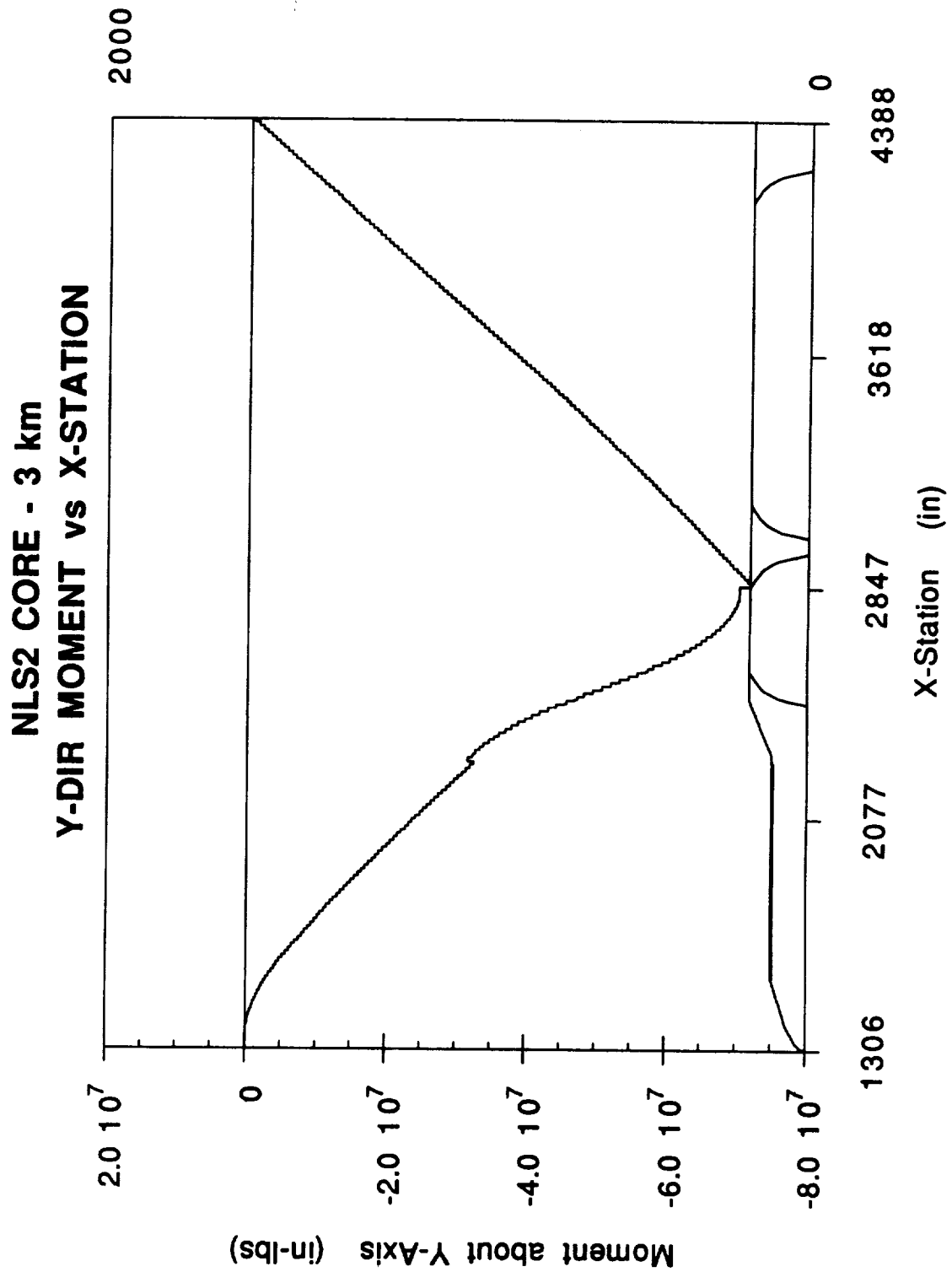

((

**NLS2 CORE - 3 km
Z-DIR MOMENT vs X-STATION**

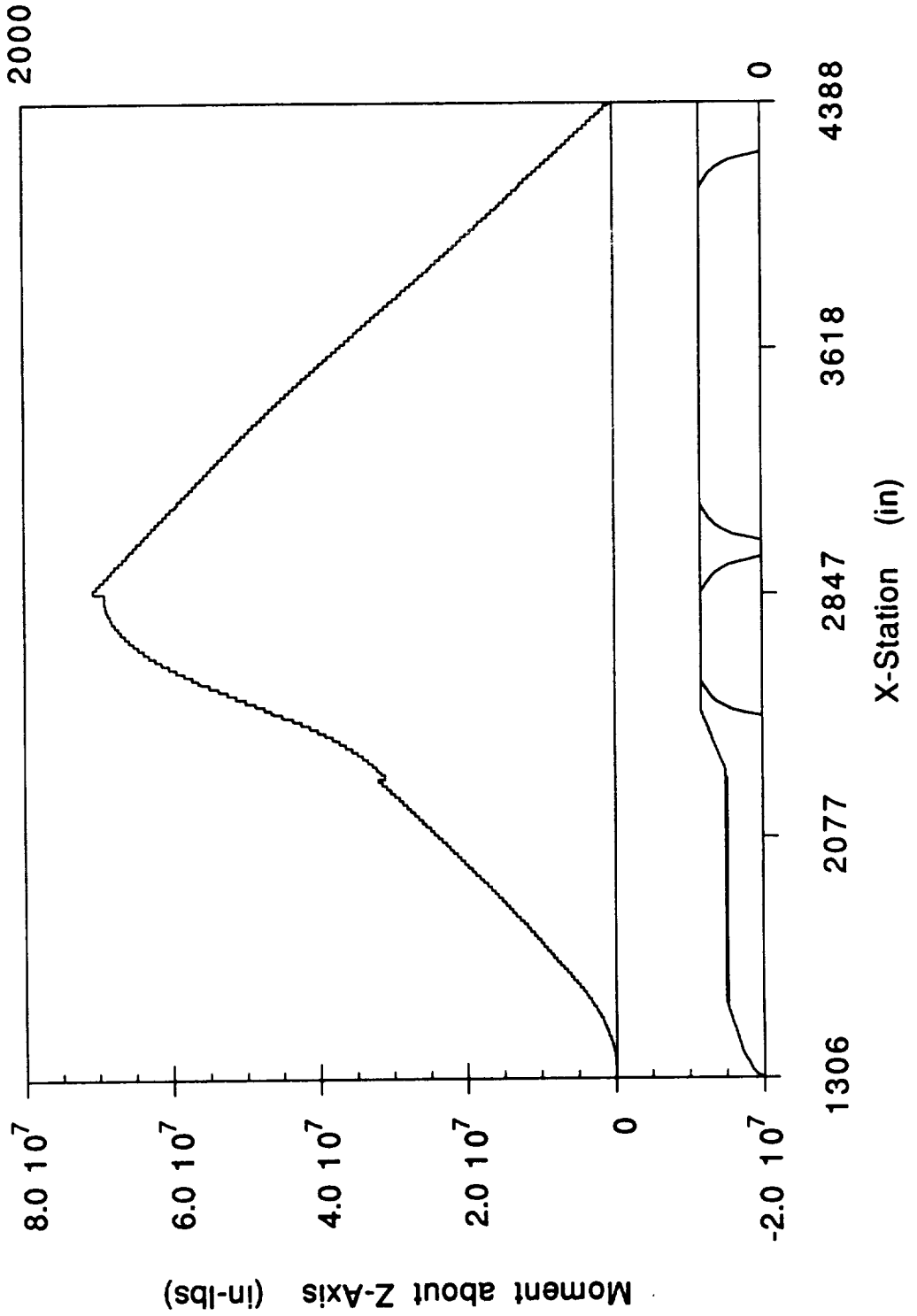

**NLS2 CORE - 3 km
Y-DIR MOMENT vs X-STATION**

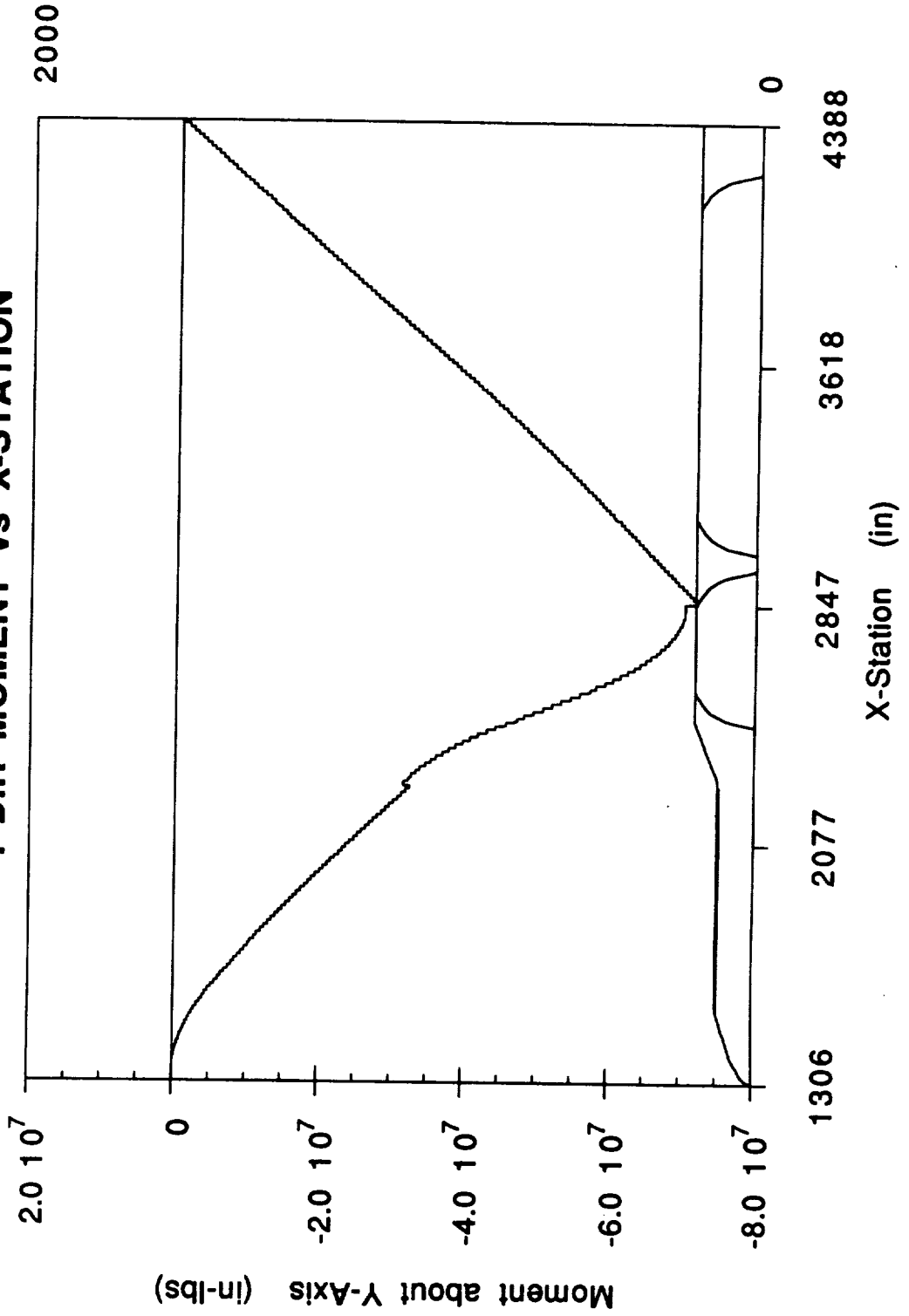

**NLS2 CORE - 3 km
Z-DIR MOMENT VS X-STATION**

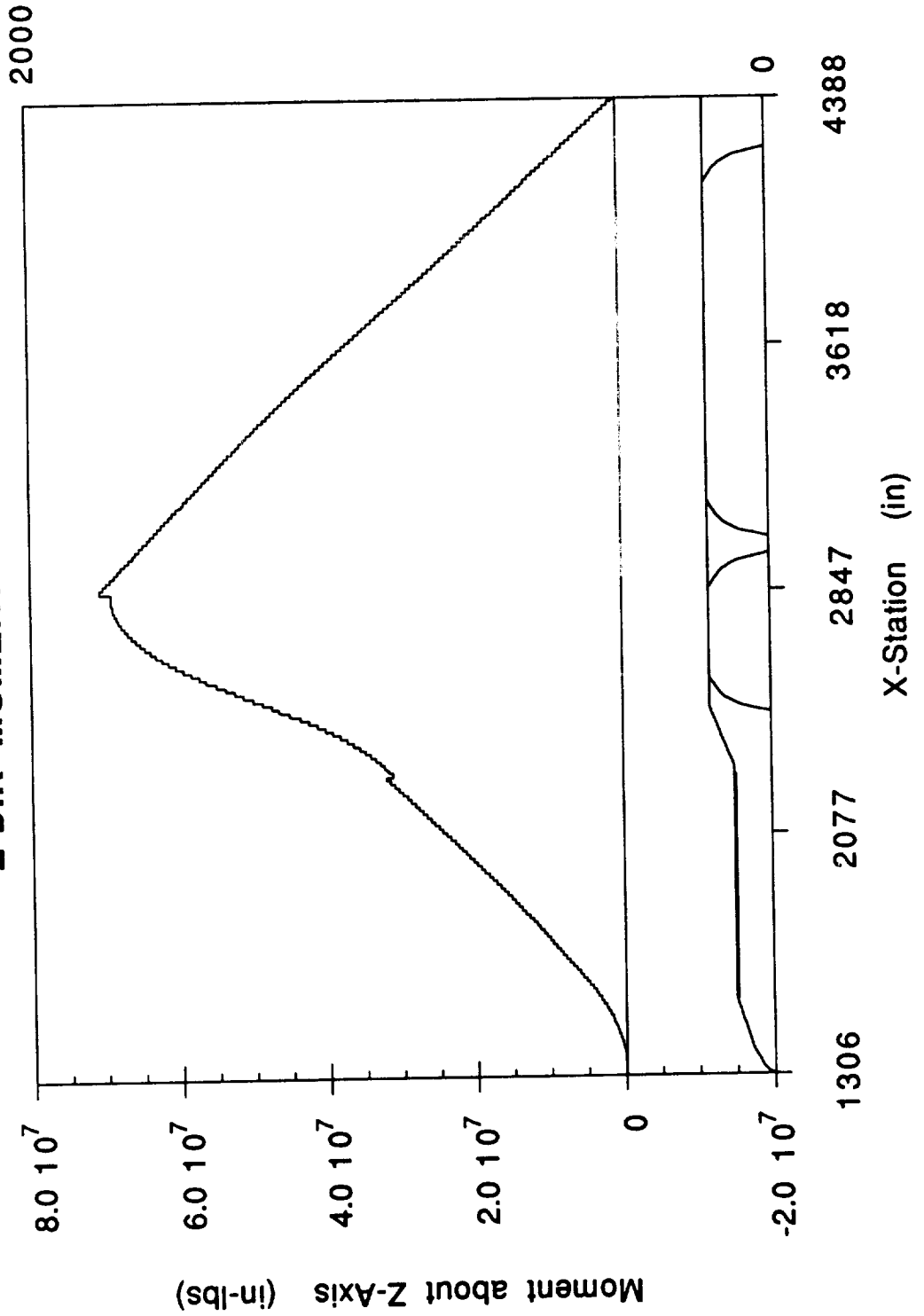

**NLS2 CORE 3 km
P EQUIVALENT vs X-STATION**

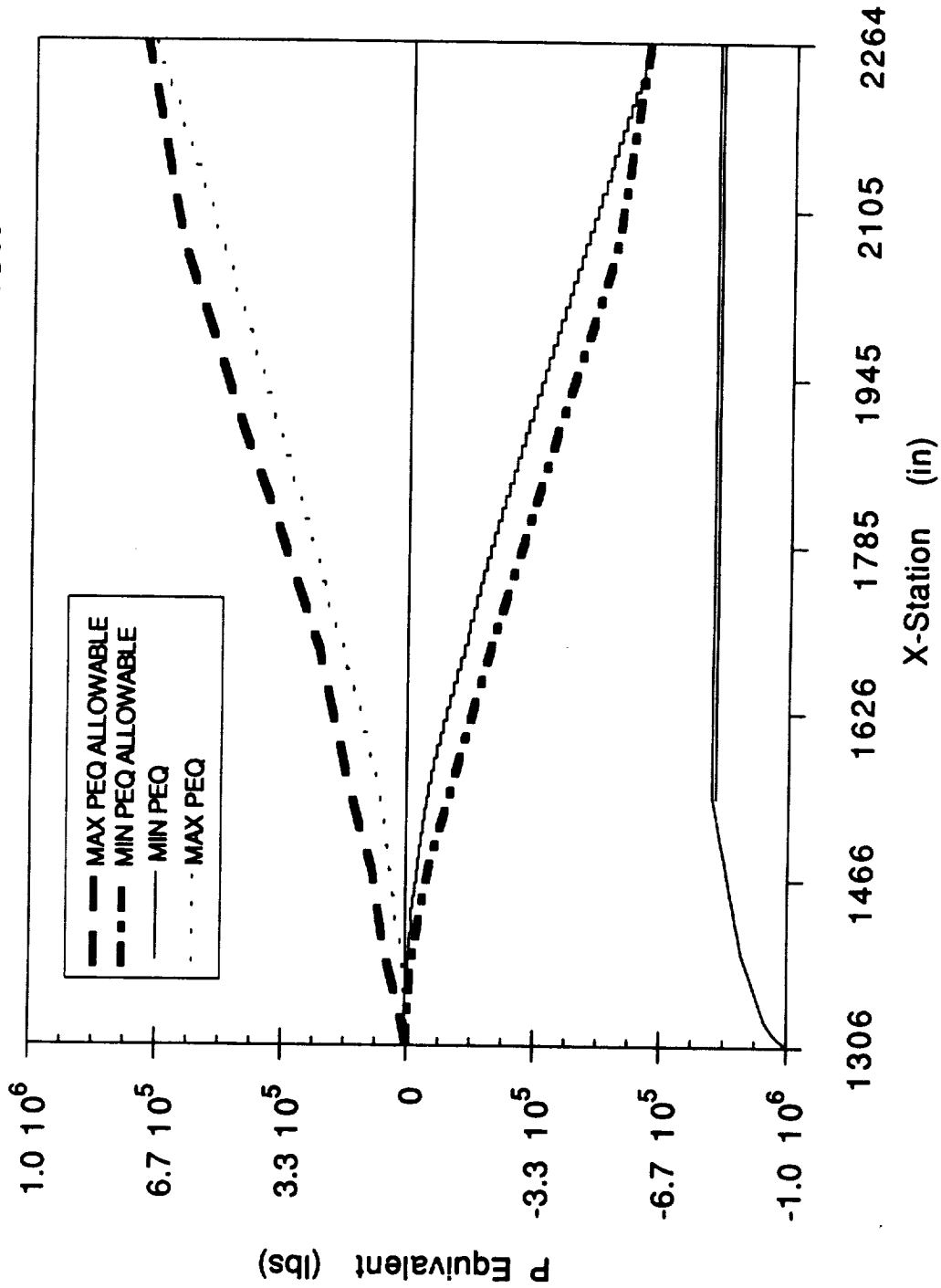

NLS2 CORE 3 km V EQUIVALENT vs X-STATION

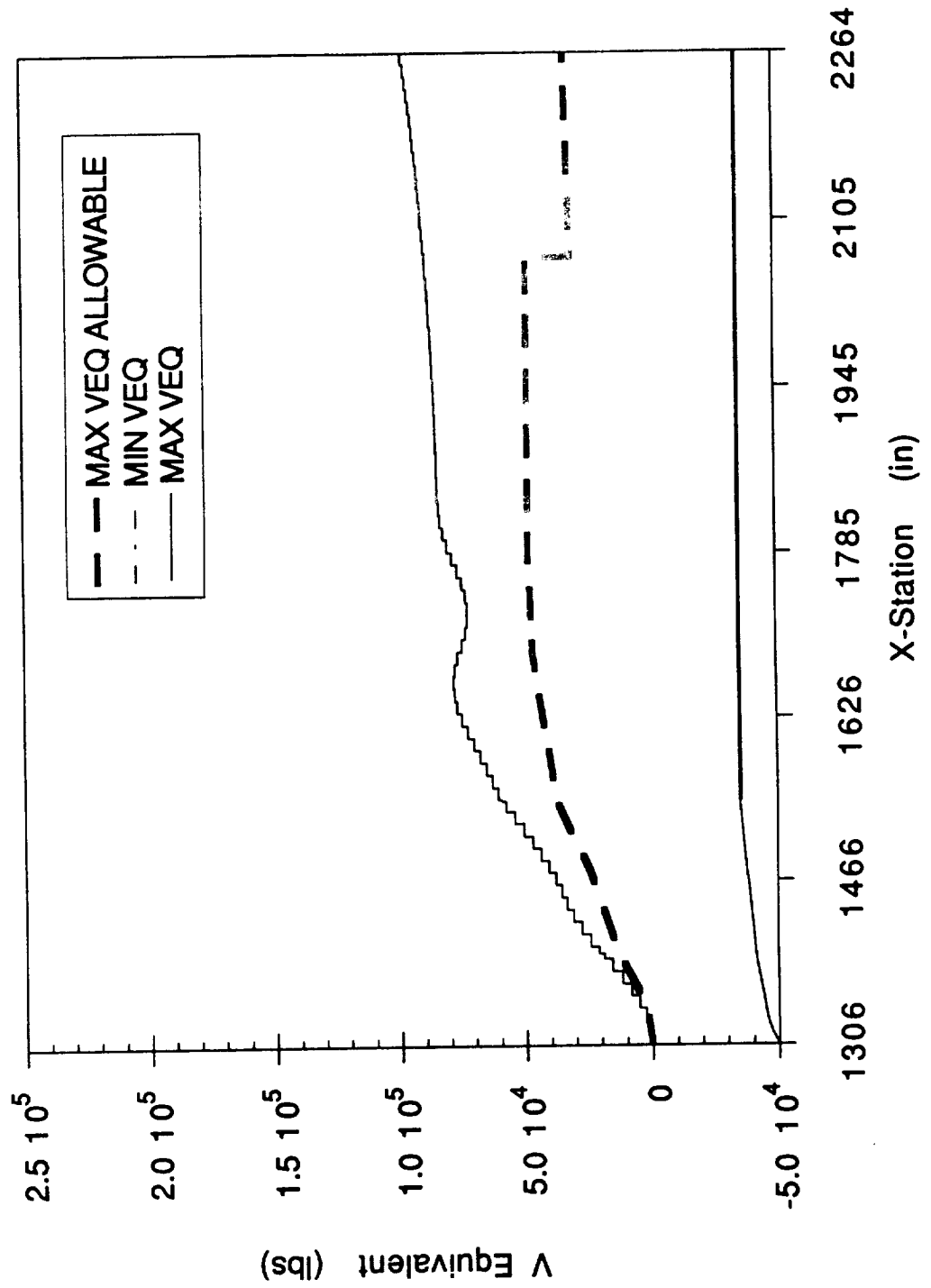

NLS2 CORE - 6 km NX vs X-STATION

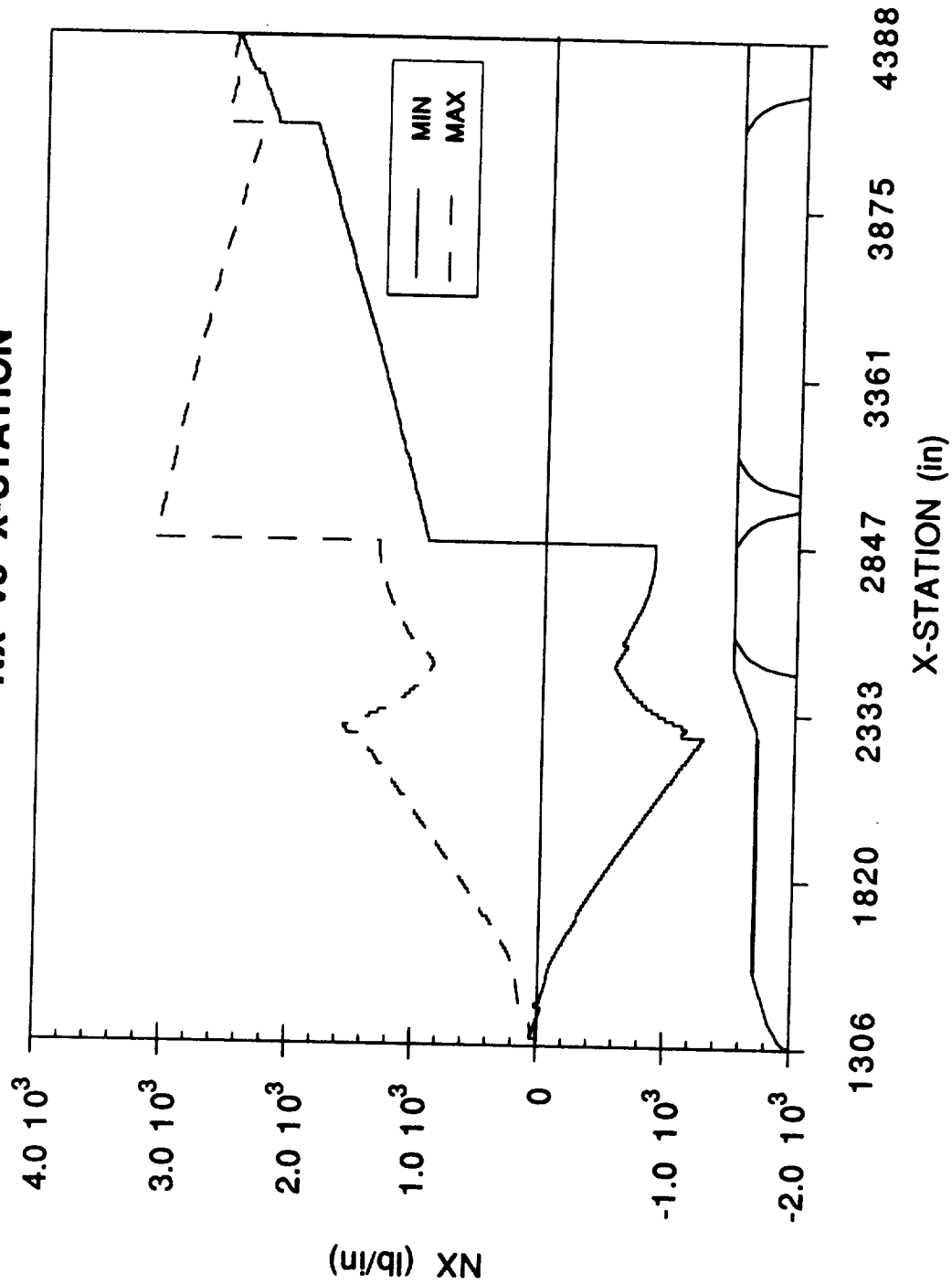

((

**NLS2 CORE - 6 km
NV vs X-STATION**

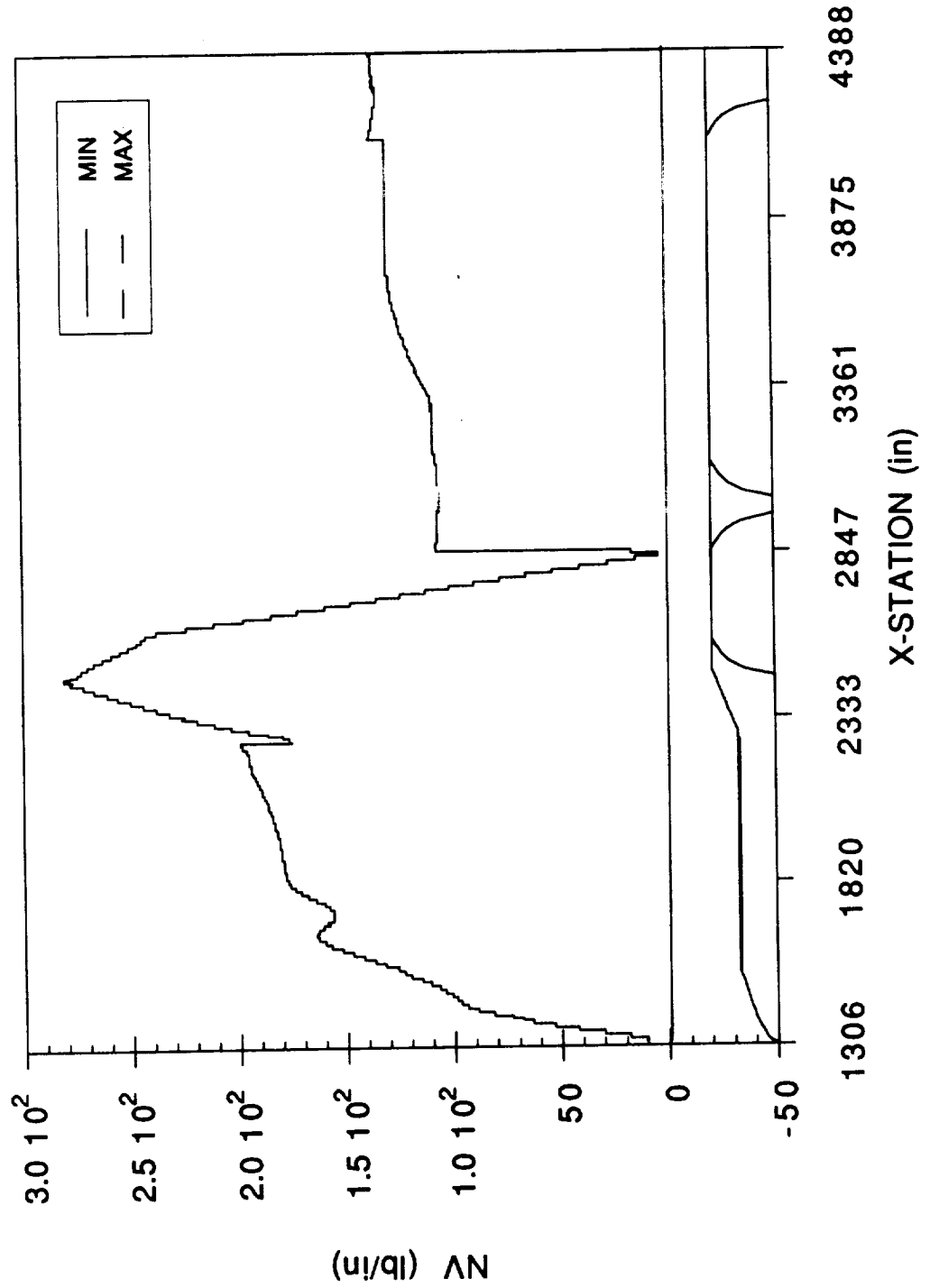

**NLS2 CORE - 6 km
AXIAL SHEAR vs X-STATION**

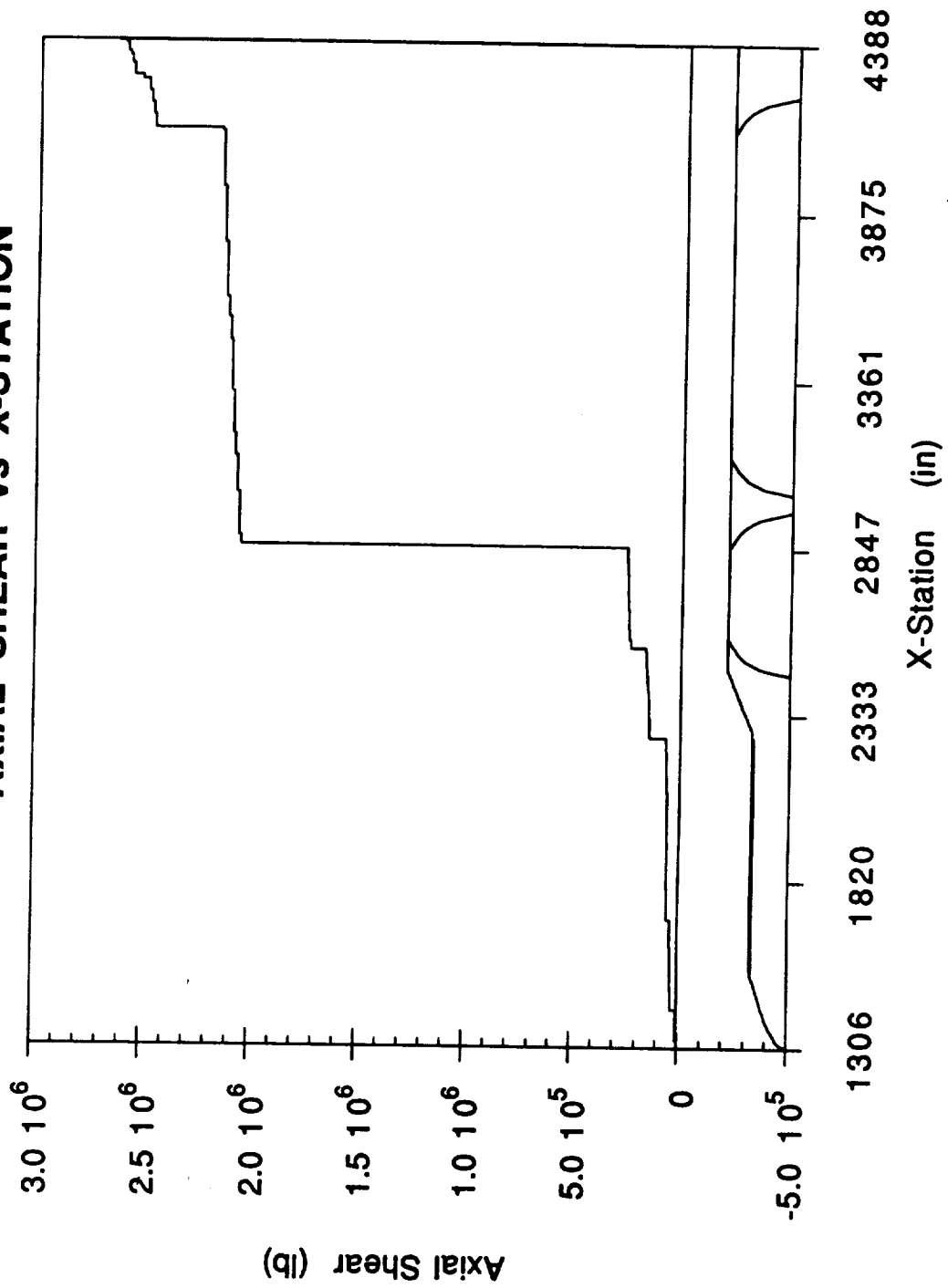

NLS2 CORE - 6 km
Y-DIR SHEAR vs X-STATION

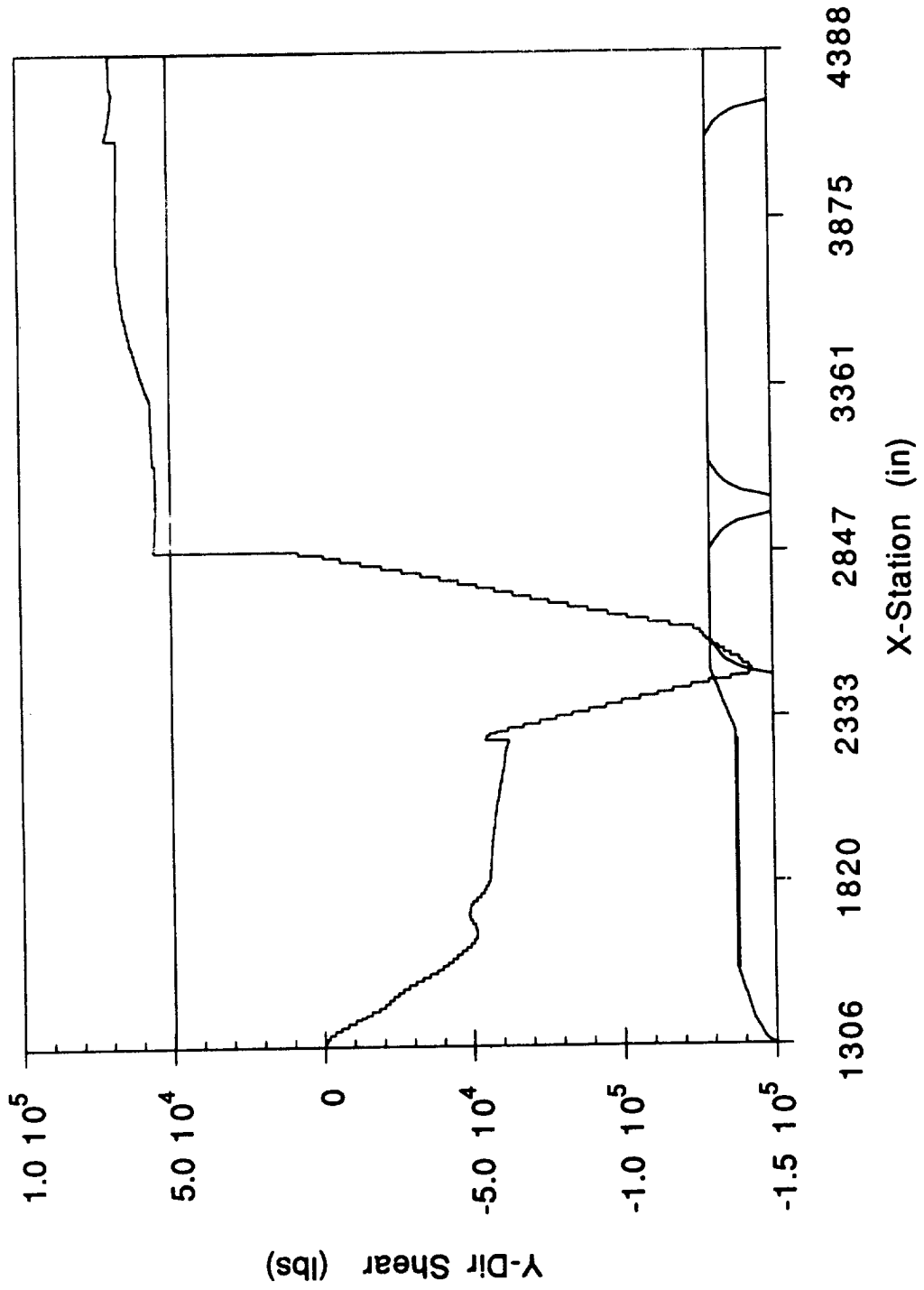

**NLS2 CORE - 6 km
Z-DIR SHEAR vs X-STATION**

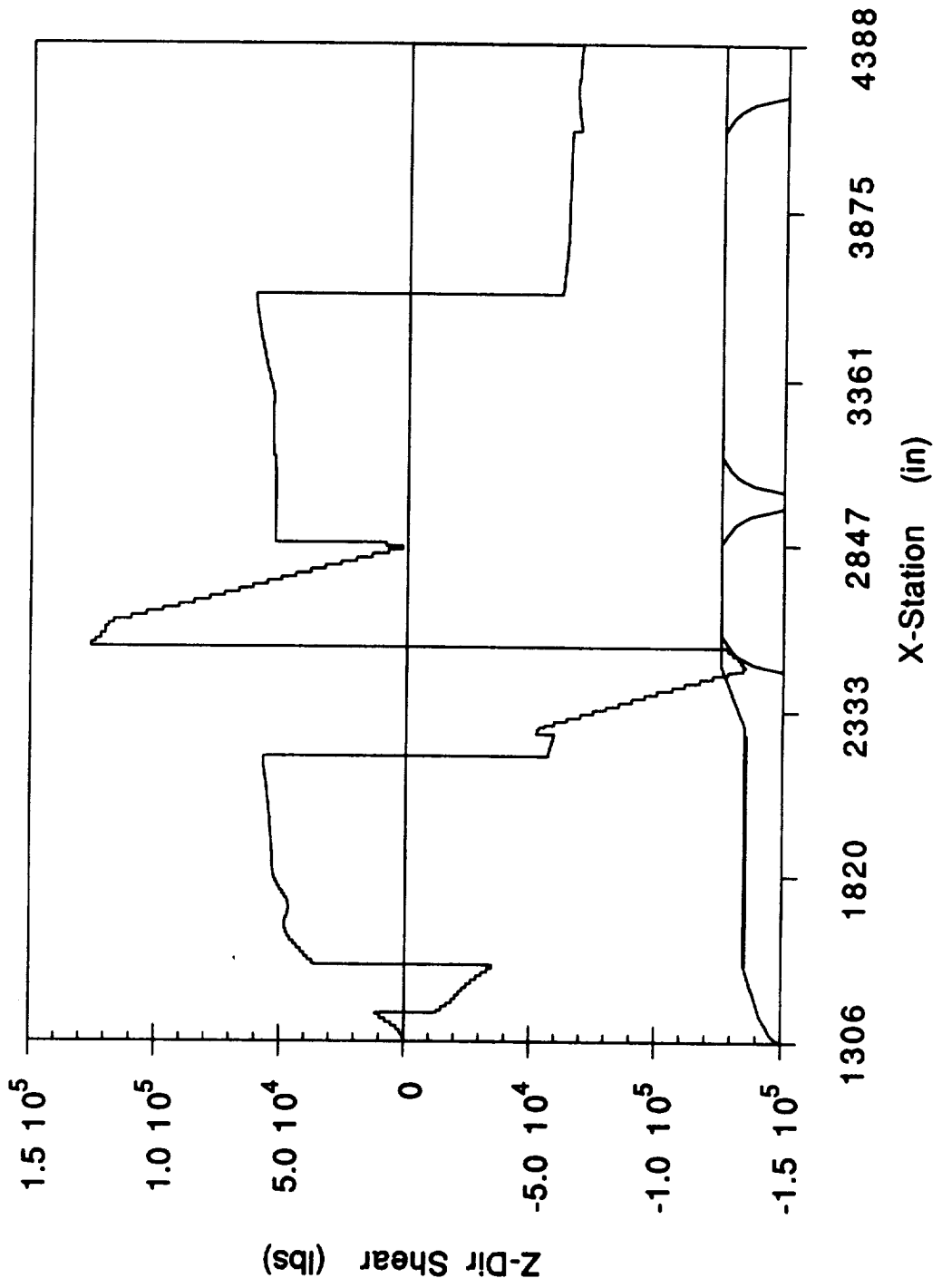

**NLS2 CORE - 6 km
Y-DIR MOMENT vs X-STATION**

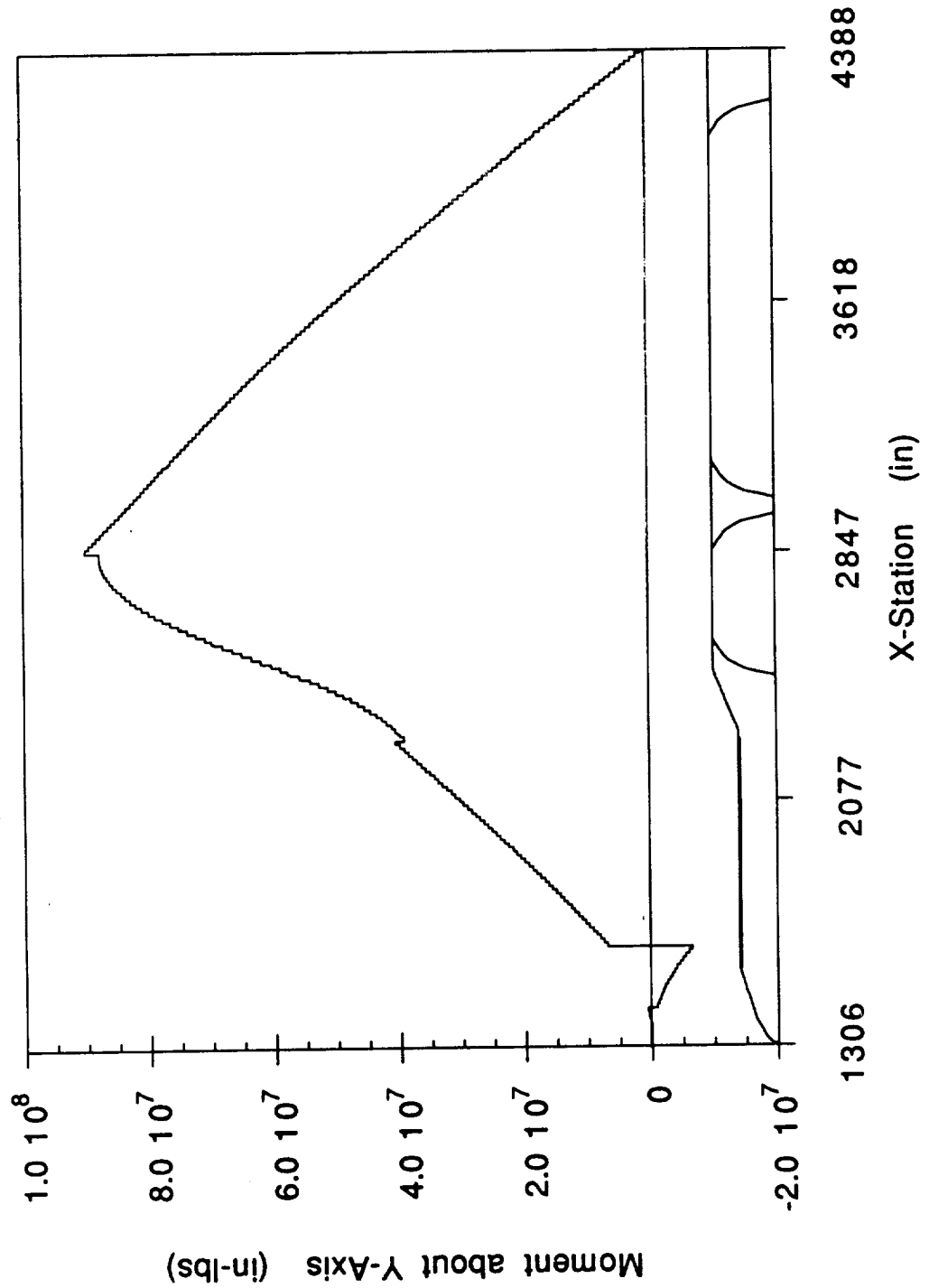

NLS2 CORE - 6 km Z-DIR MOMENT vs X-STATION

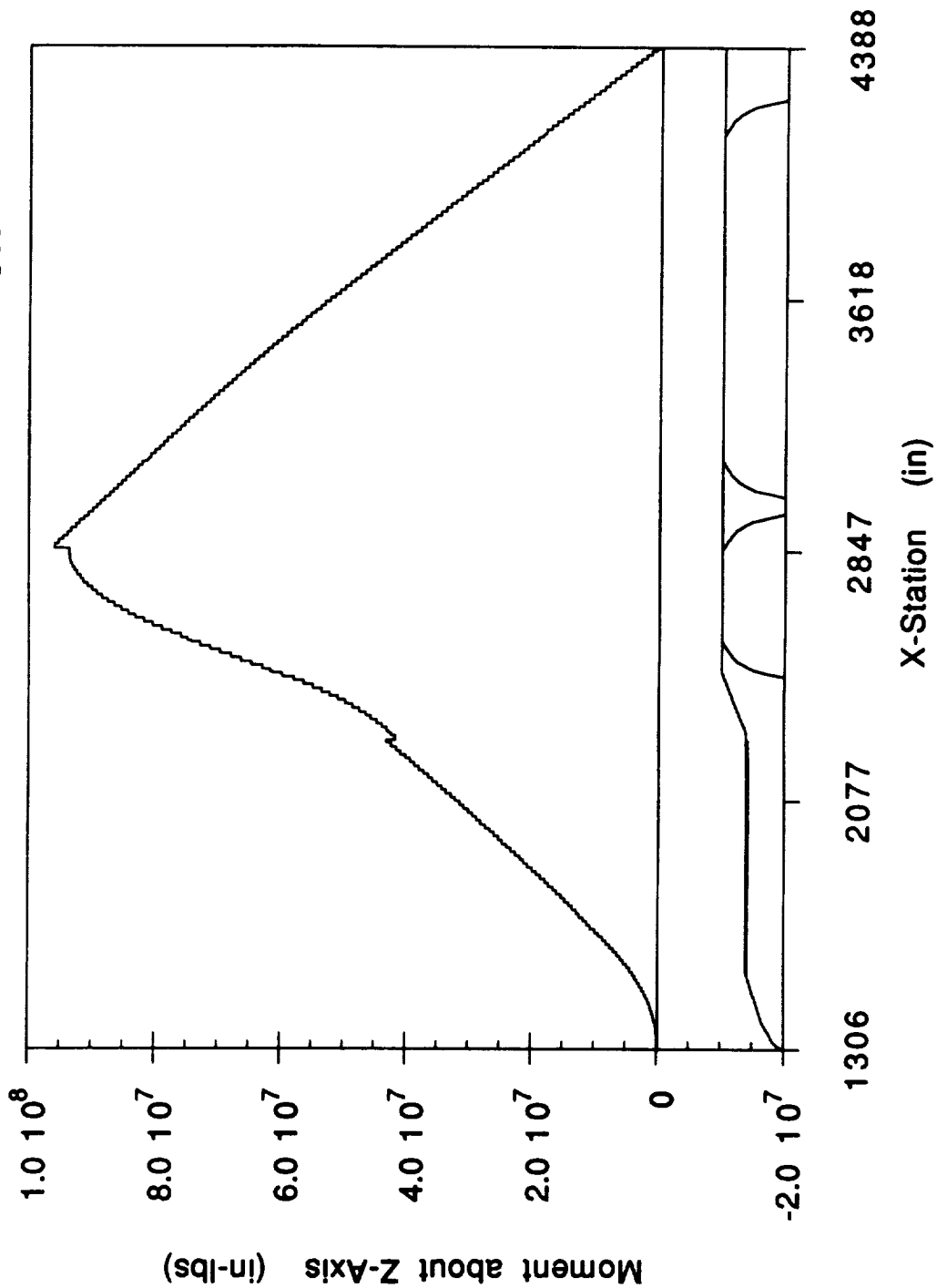

(((

**NLS2 CORE 6 km
P EQUIVALENT vs X-STATION**

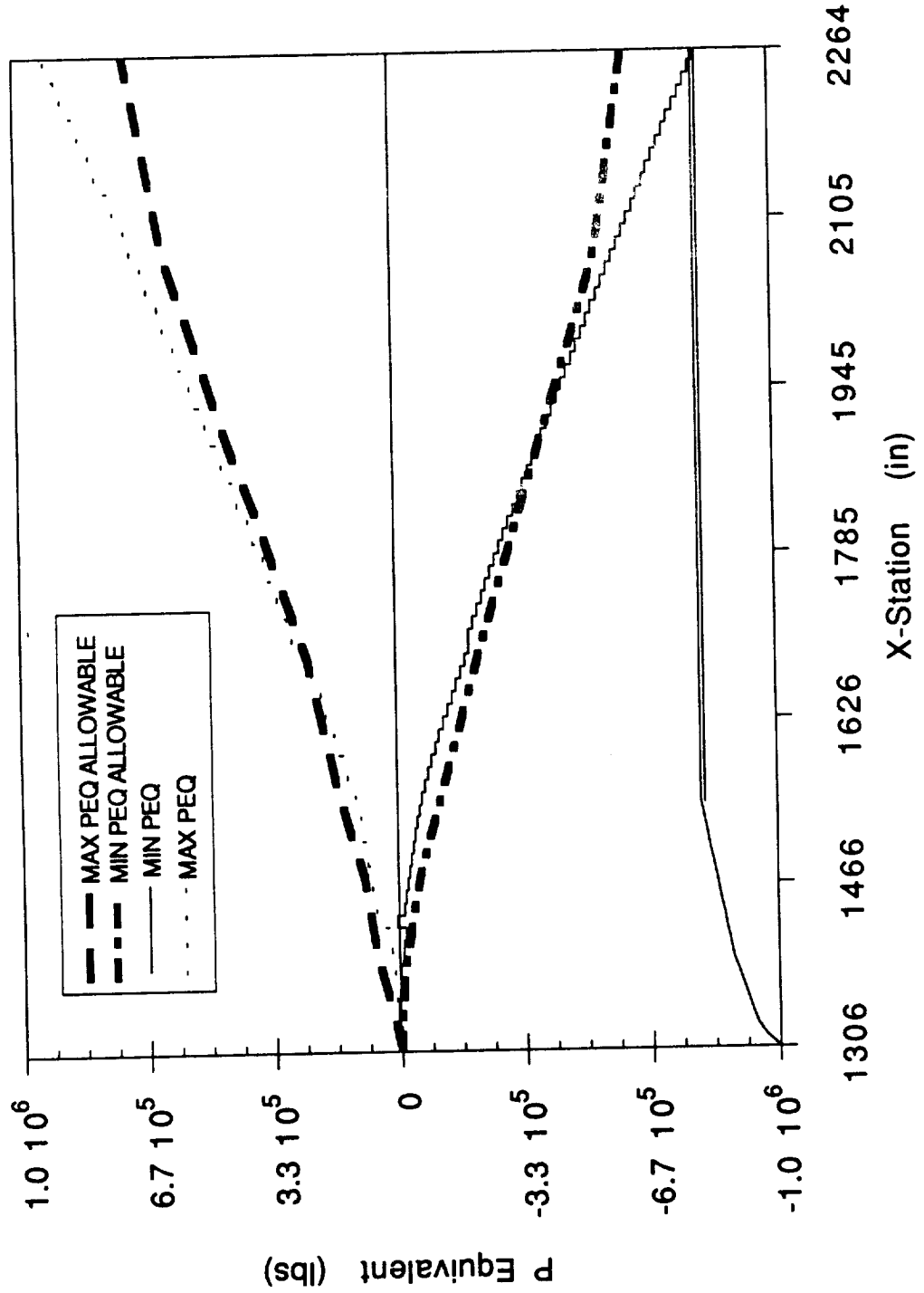

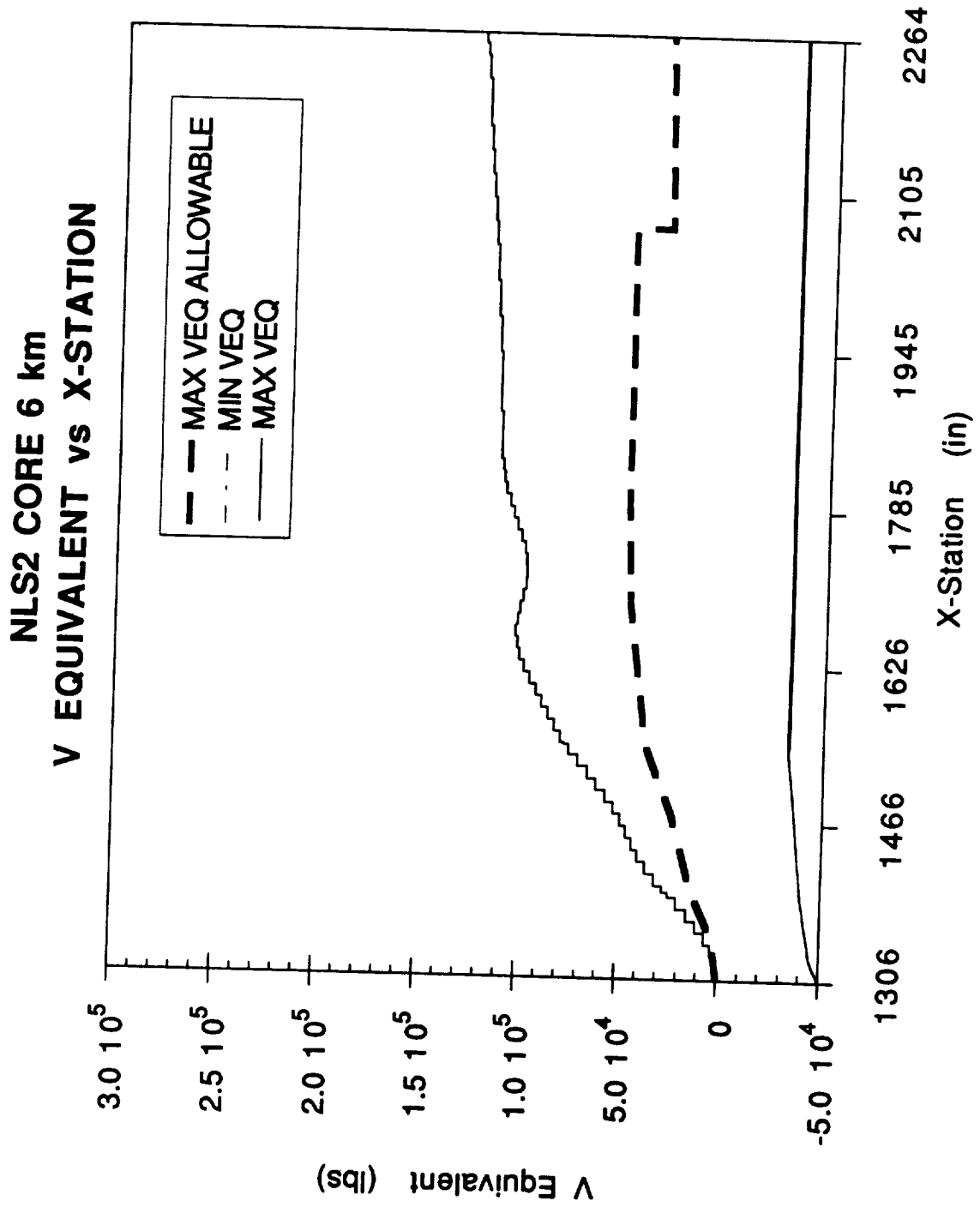

(((

**NLS2 CORE - 8km
NX vs X-STATION**

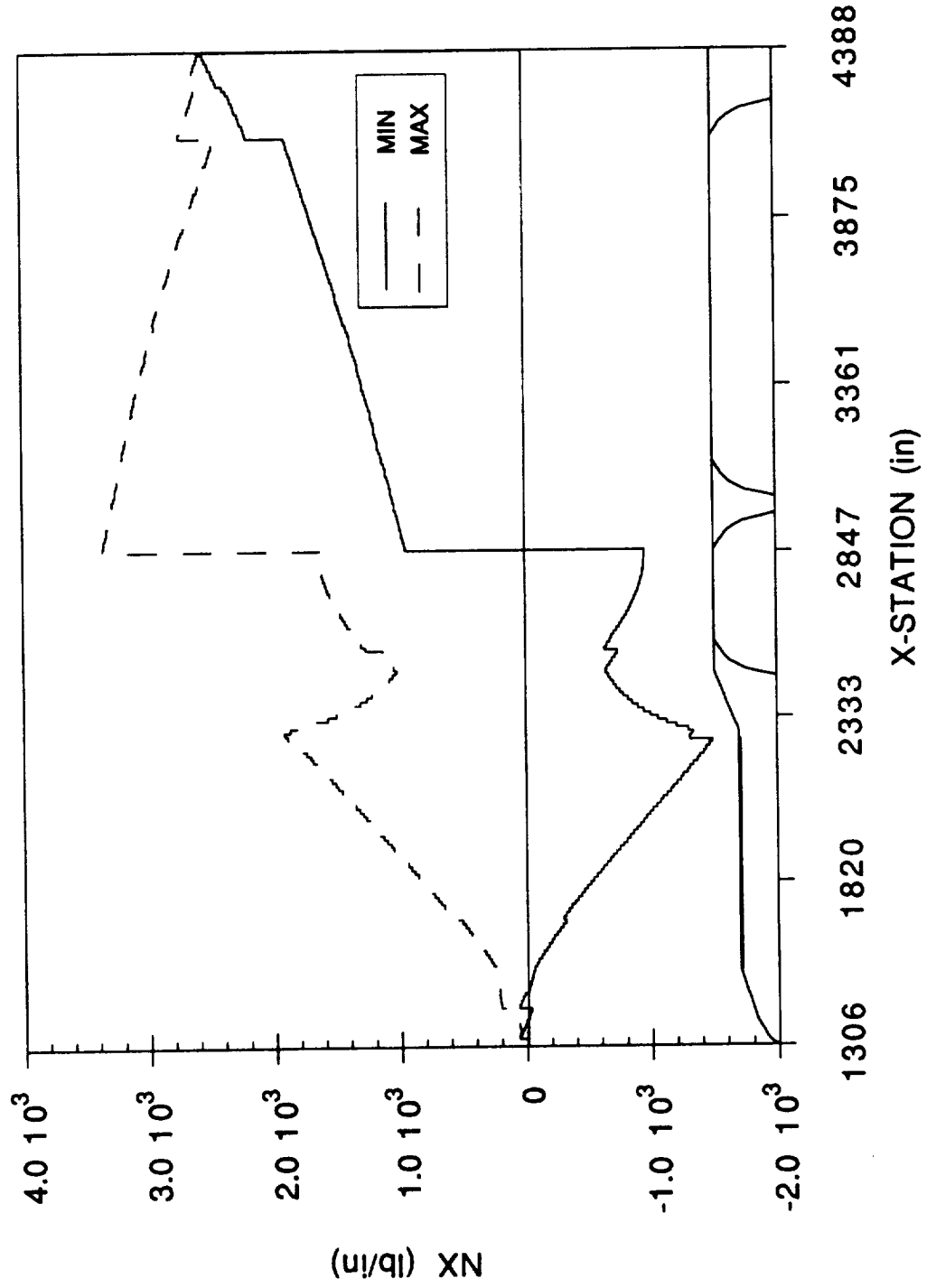

NLS2 CORE -8 km NV vs X-STATION

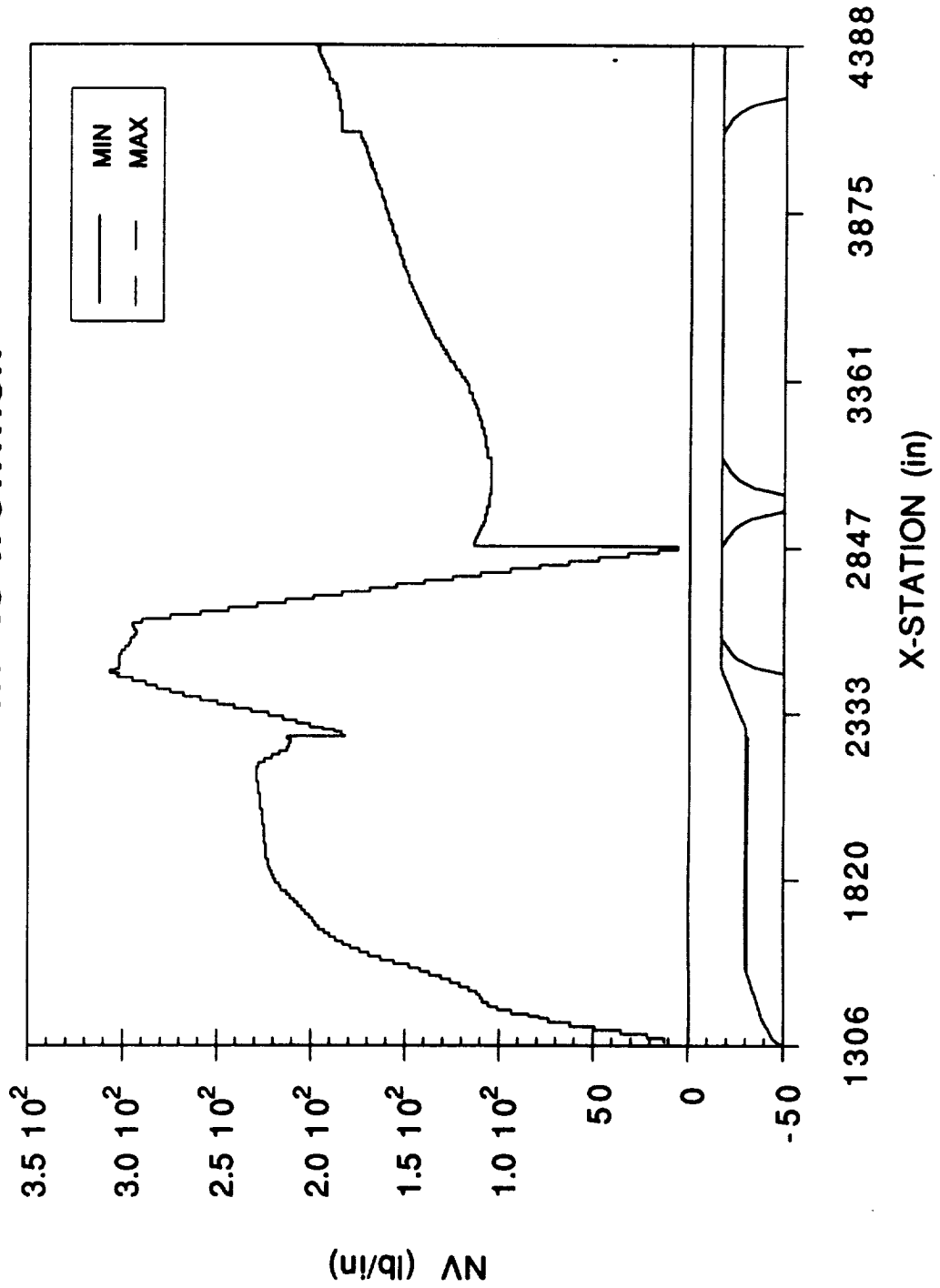

((

**NLS2 CORE - 8 km
AXIAL SHEAR vs X-STATION**

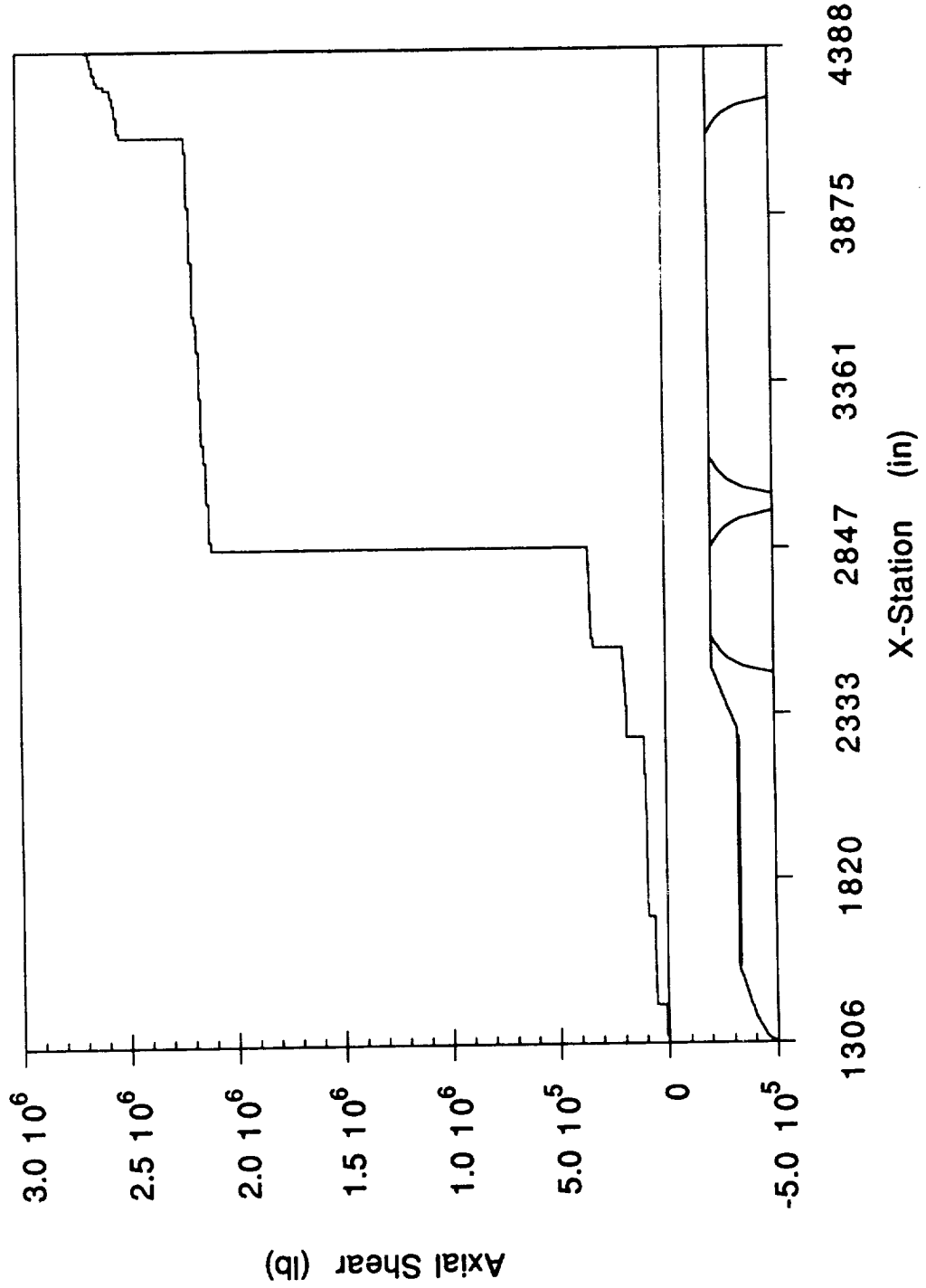

**NLS2 CORE - 8 km
Y-DIR SHEAR vs X-STATION**

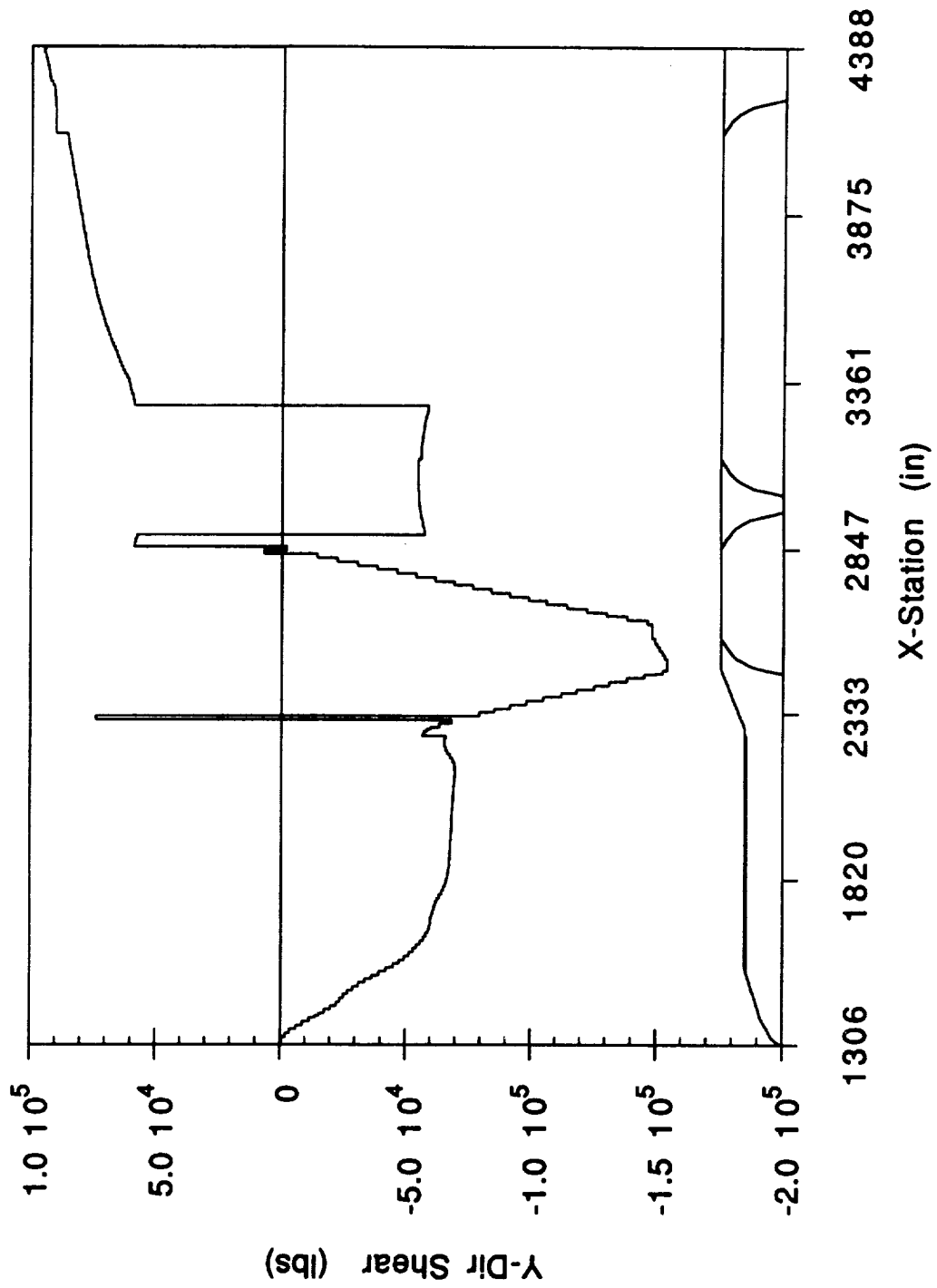

**NLS2 CORE - 8 km
Z-DIR SHEAR VS X-STATION**

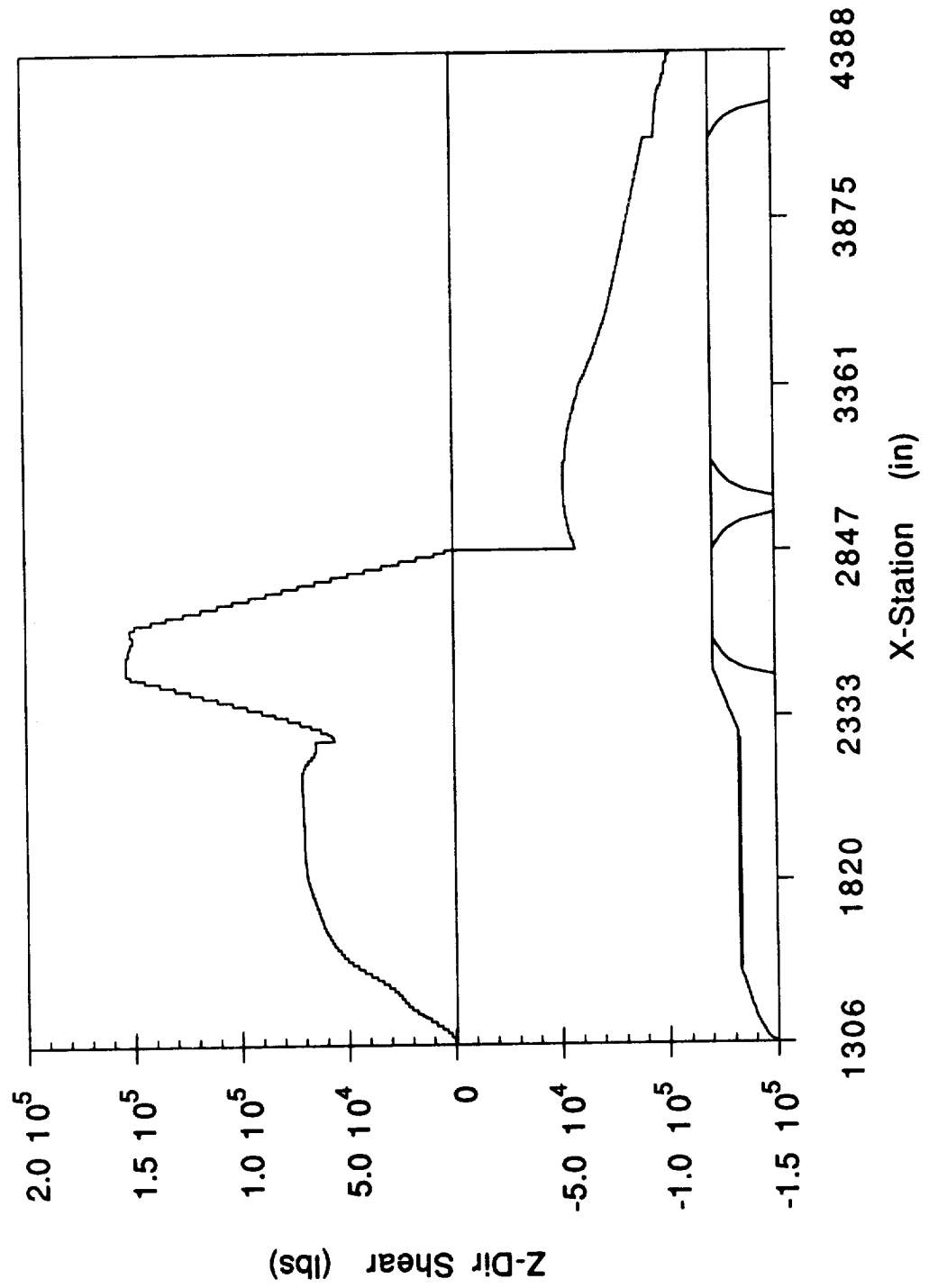

**NLS2 CORE - 8 km
Y-DIR MOMENT vs X-STATION**

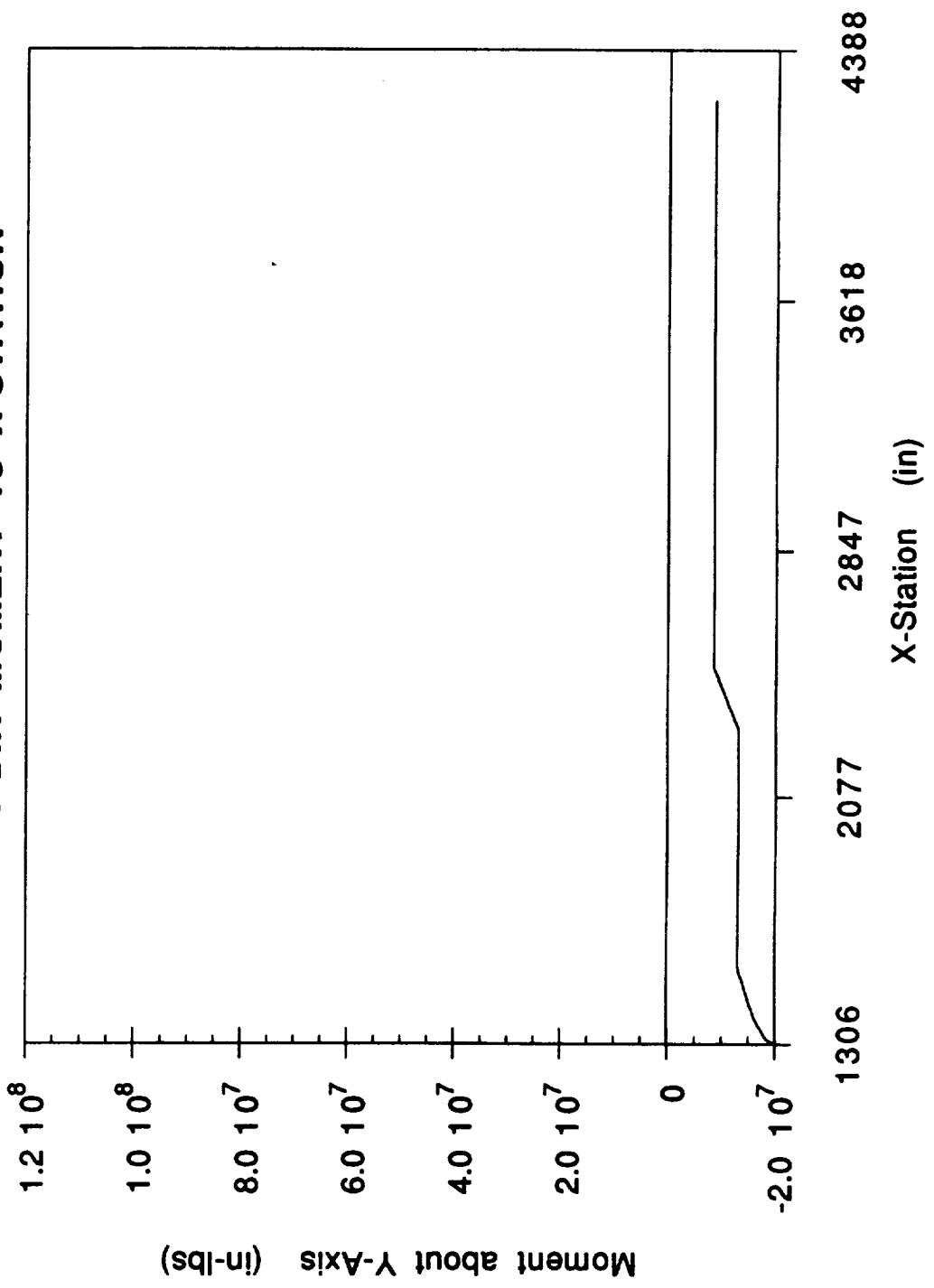

**NLS2 CORE - 8 km
Z-DIR MOMENT vs X-STATION**

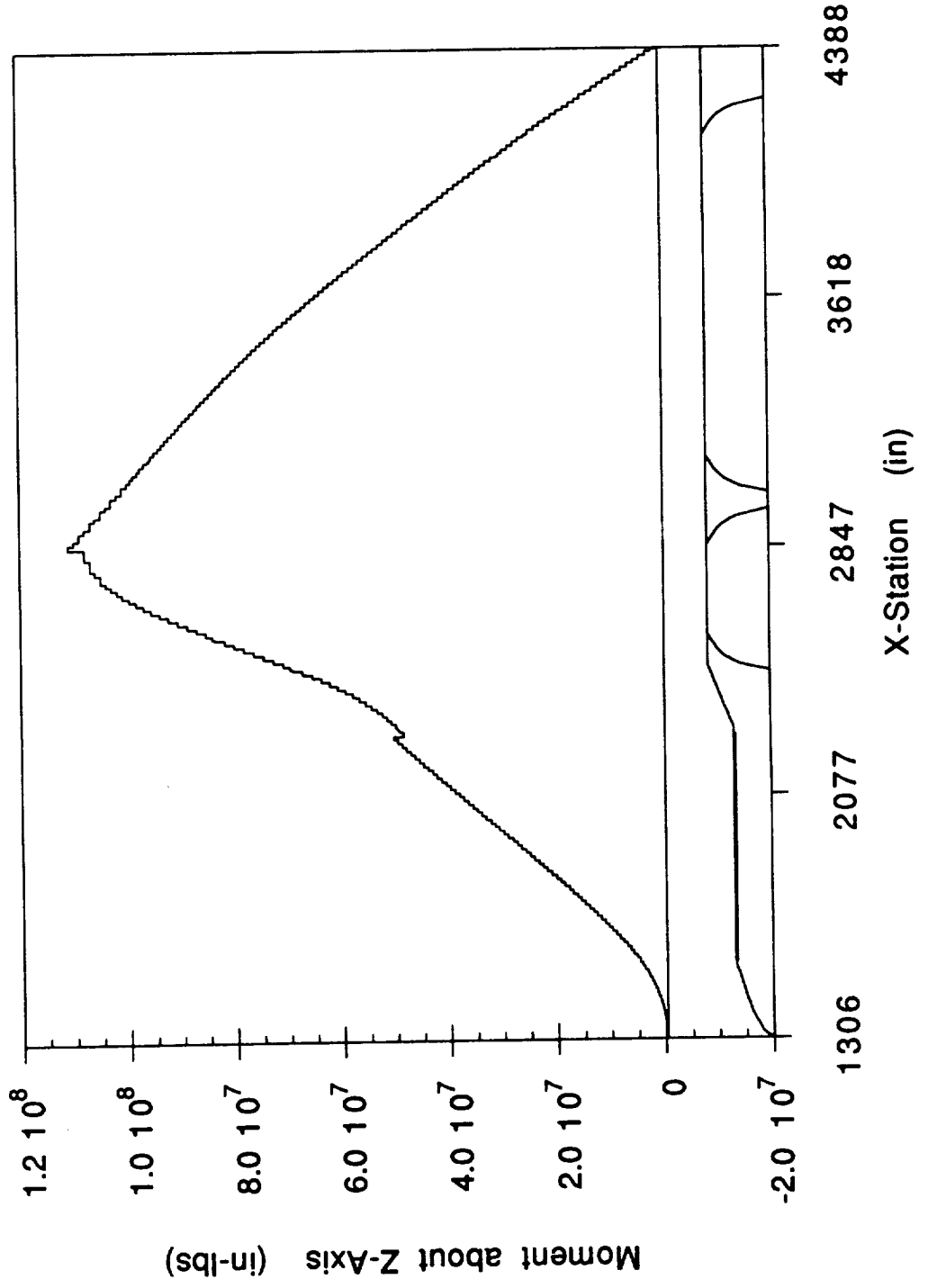

NLS2 CORE 8 km P EQUIVALENT vs X-STATION

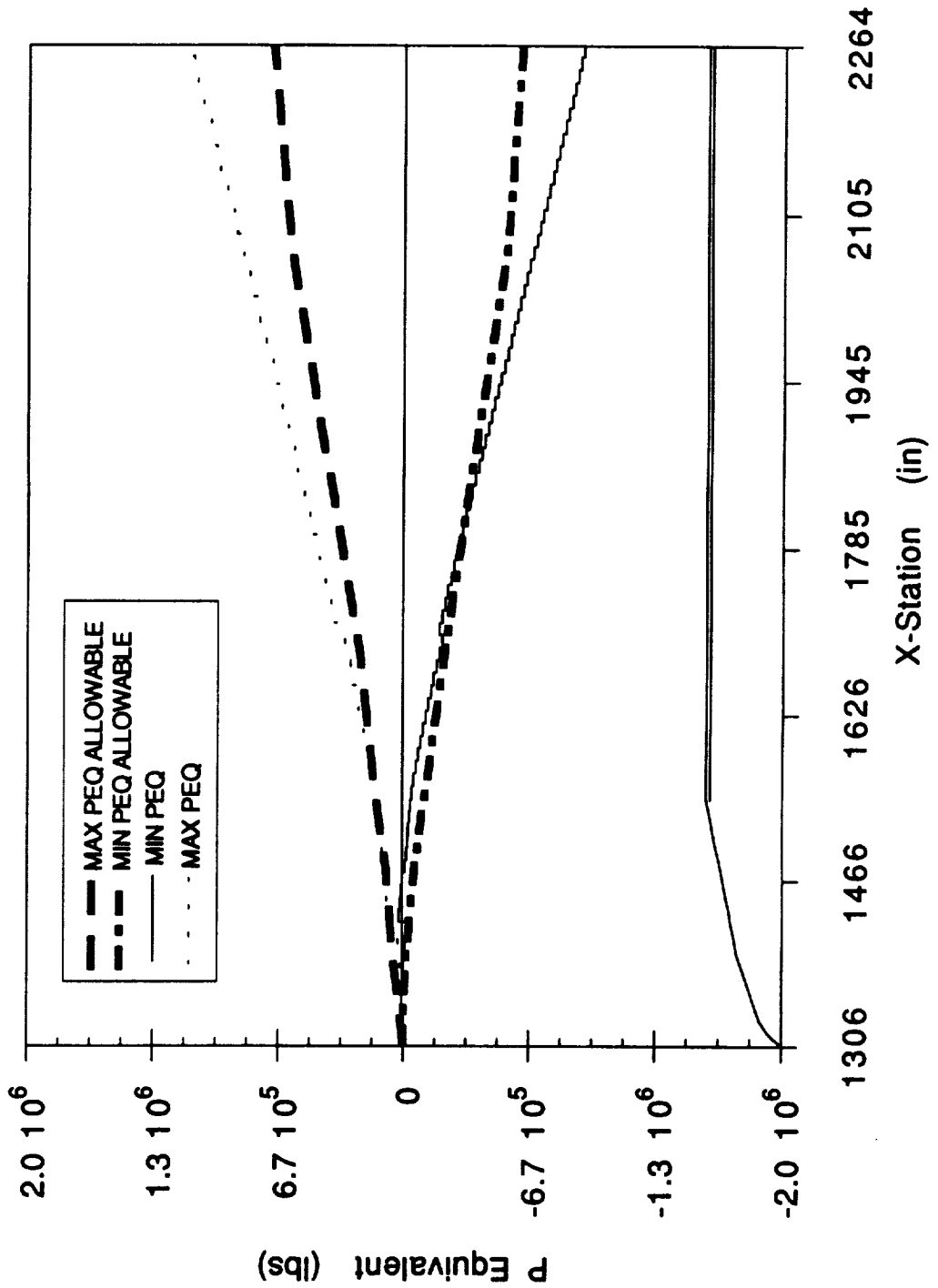

NLS2 CORE 8 km V EQUIVALENT vs X-STATION

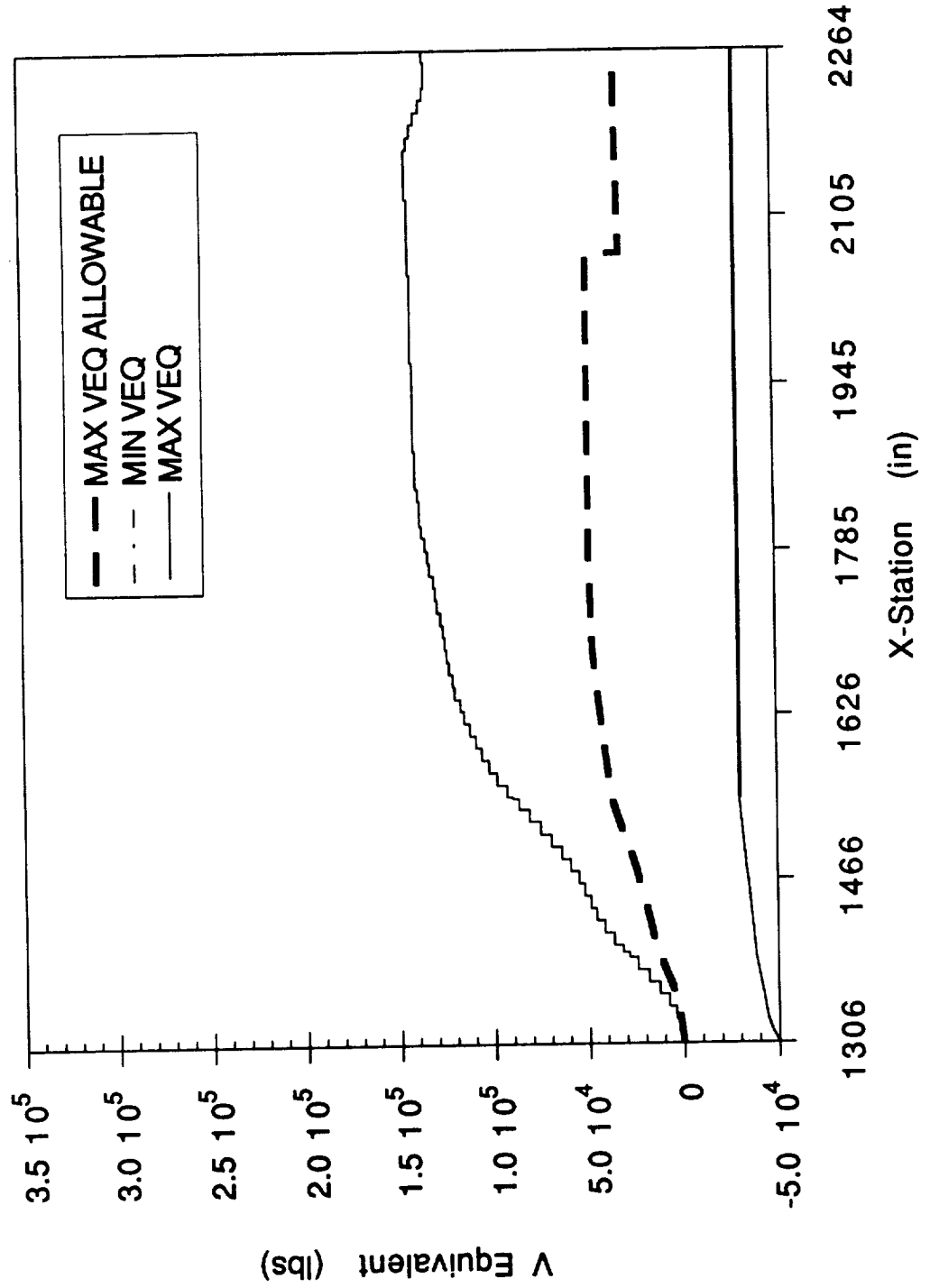

**NLS2 CORE - 9 km
NX vs X-STATION**

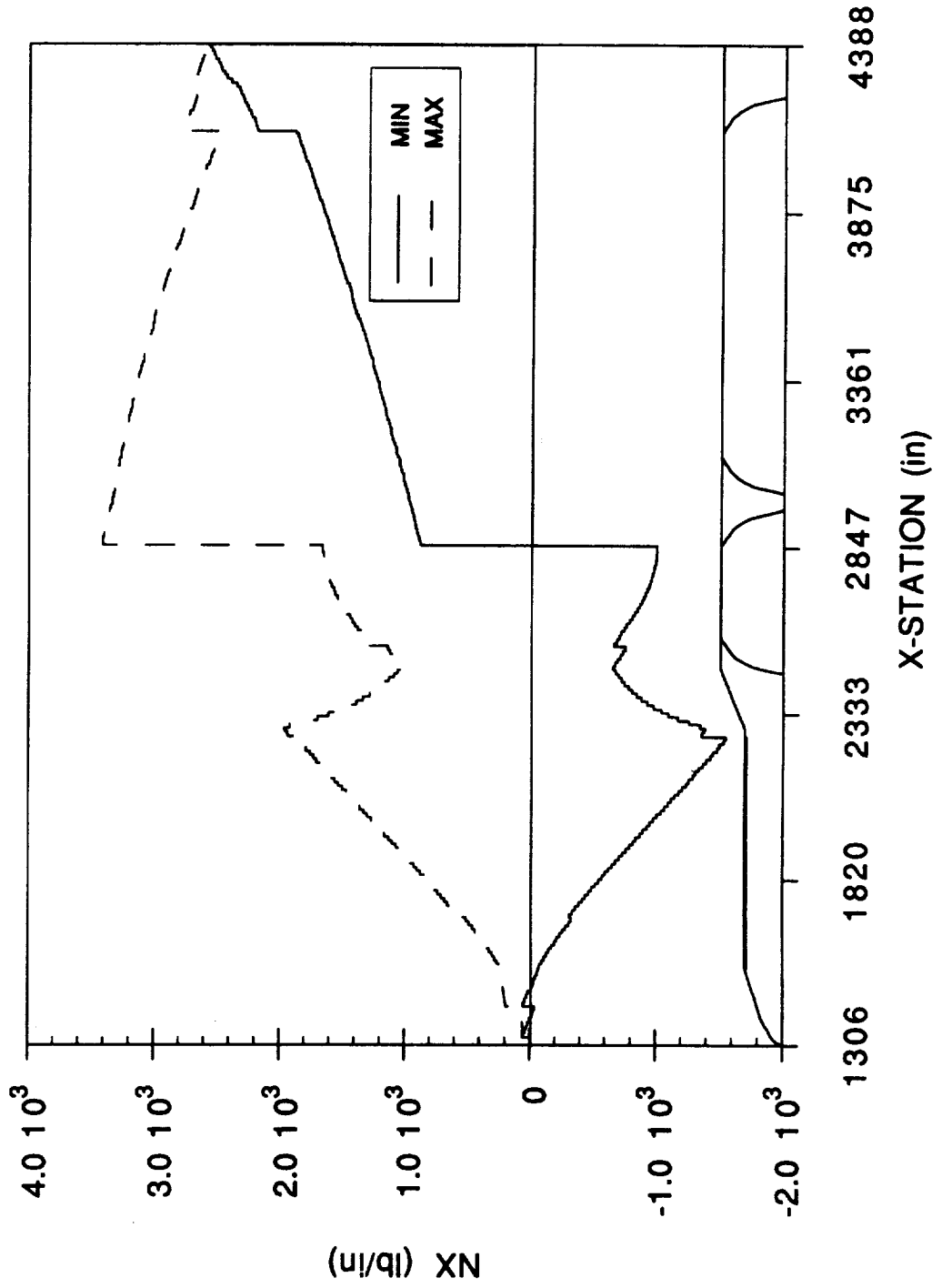

**NLS2 CORE - 9 km
NV vs X-STATION**

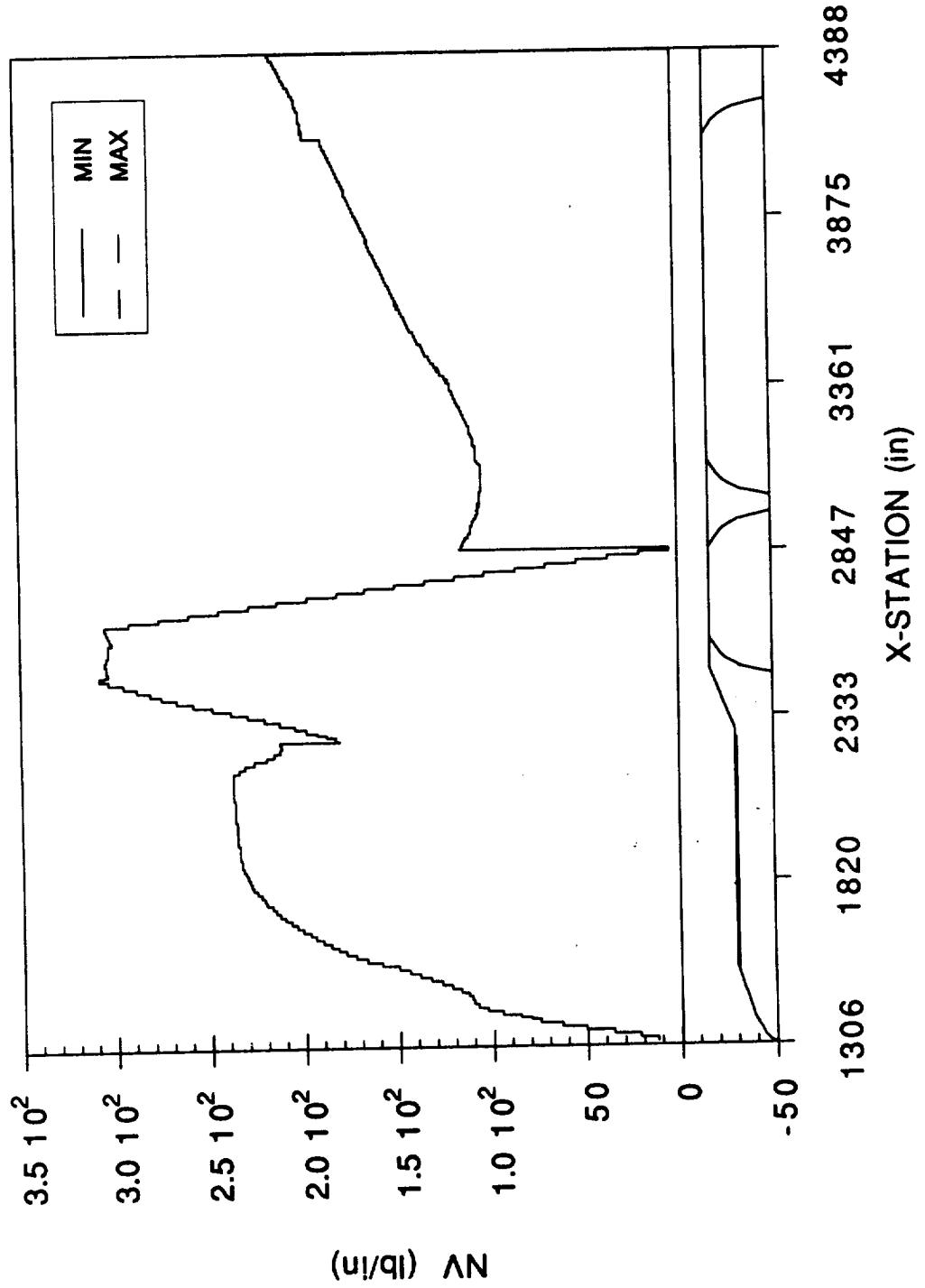

NLS2 CORE - 9 km AXIAL SHEAR vs X-STATION

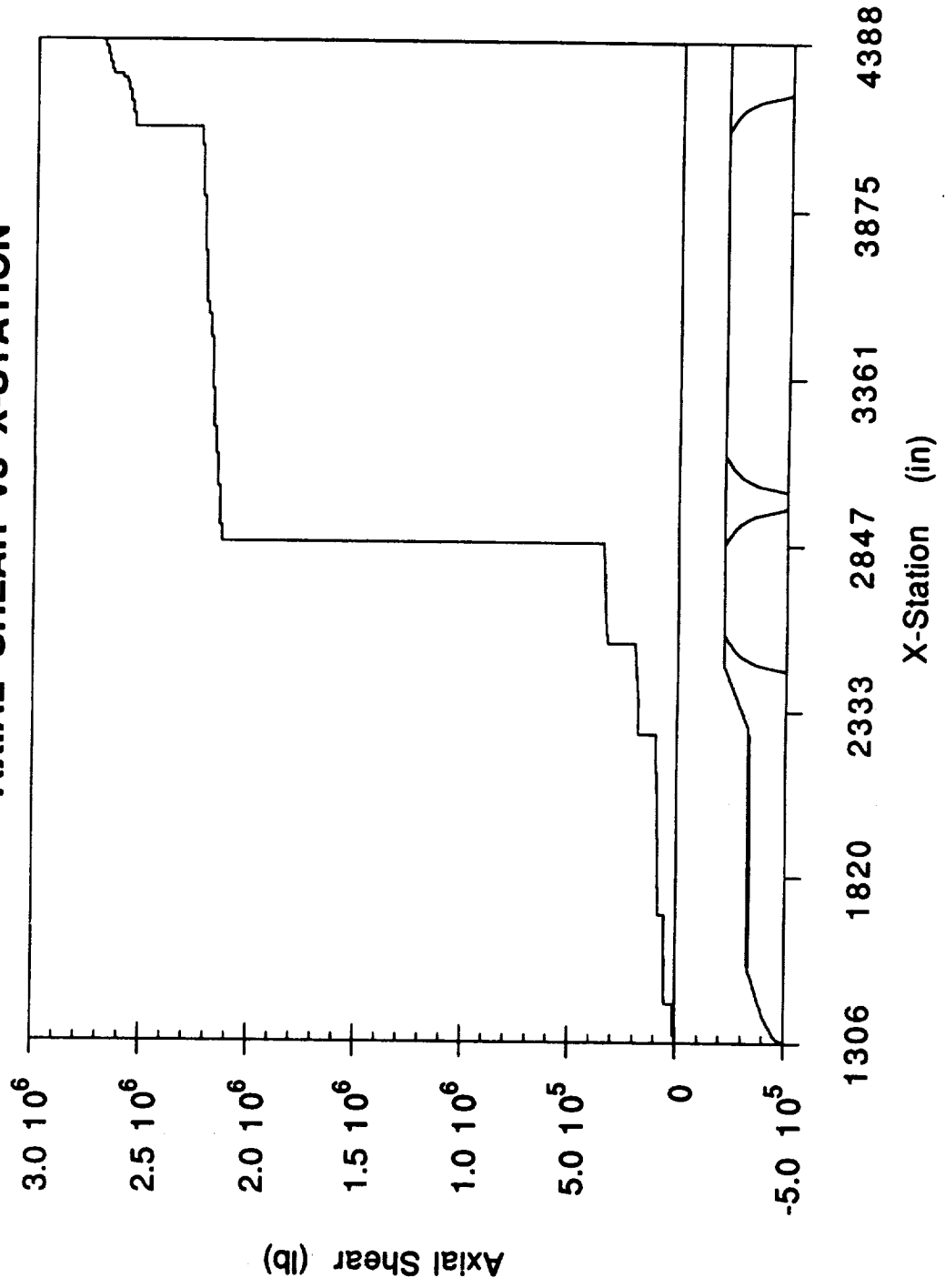

(((

**NLS2 CORE - 9 km
Y-DIR SHEAR vs X-STATION**

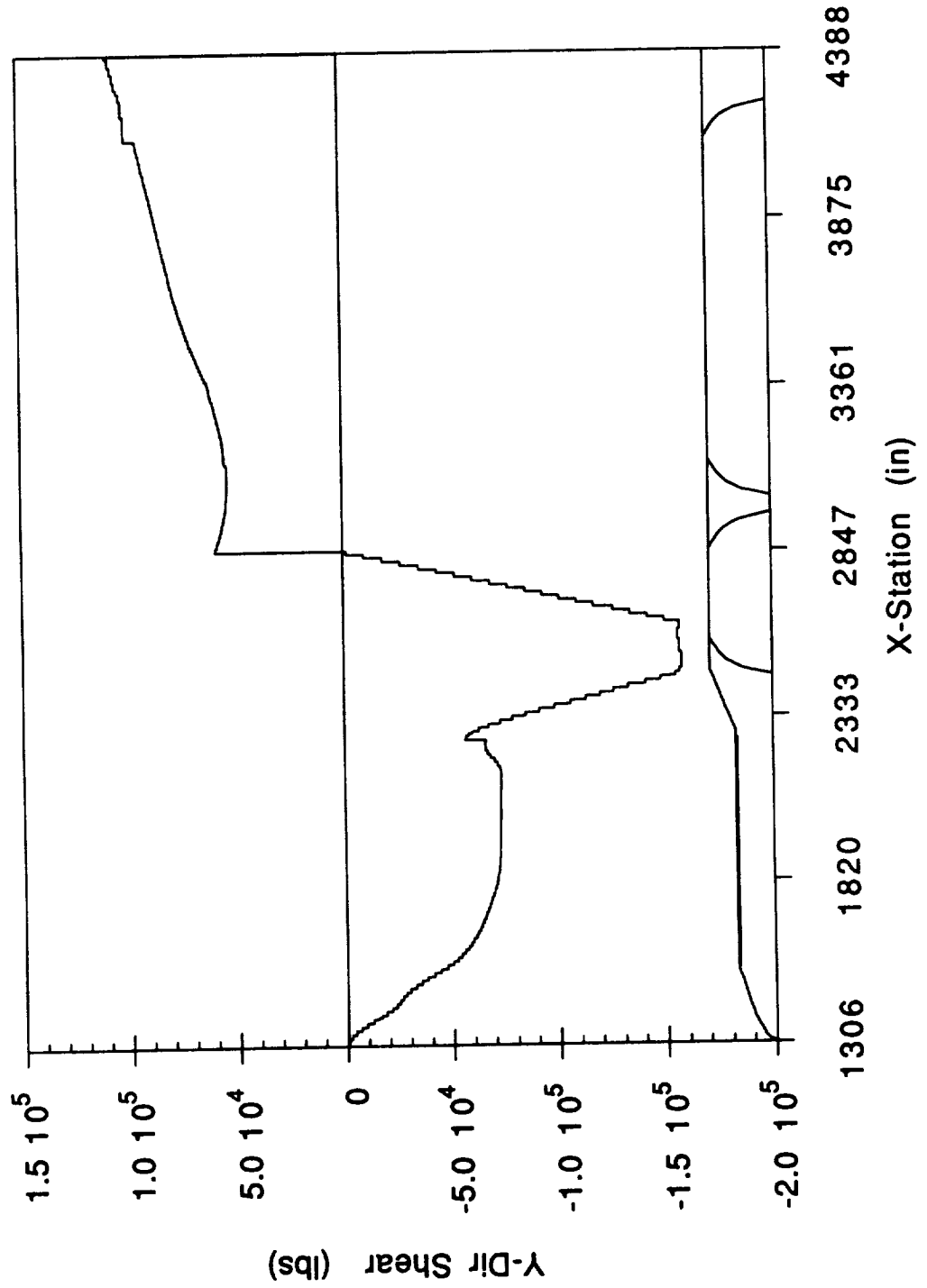

**NLS2 CORE - 9 km
Z-DIR SHEAR vs X-STATION**

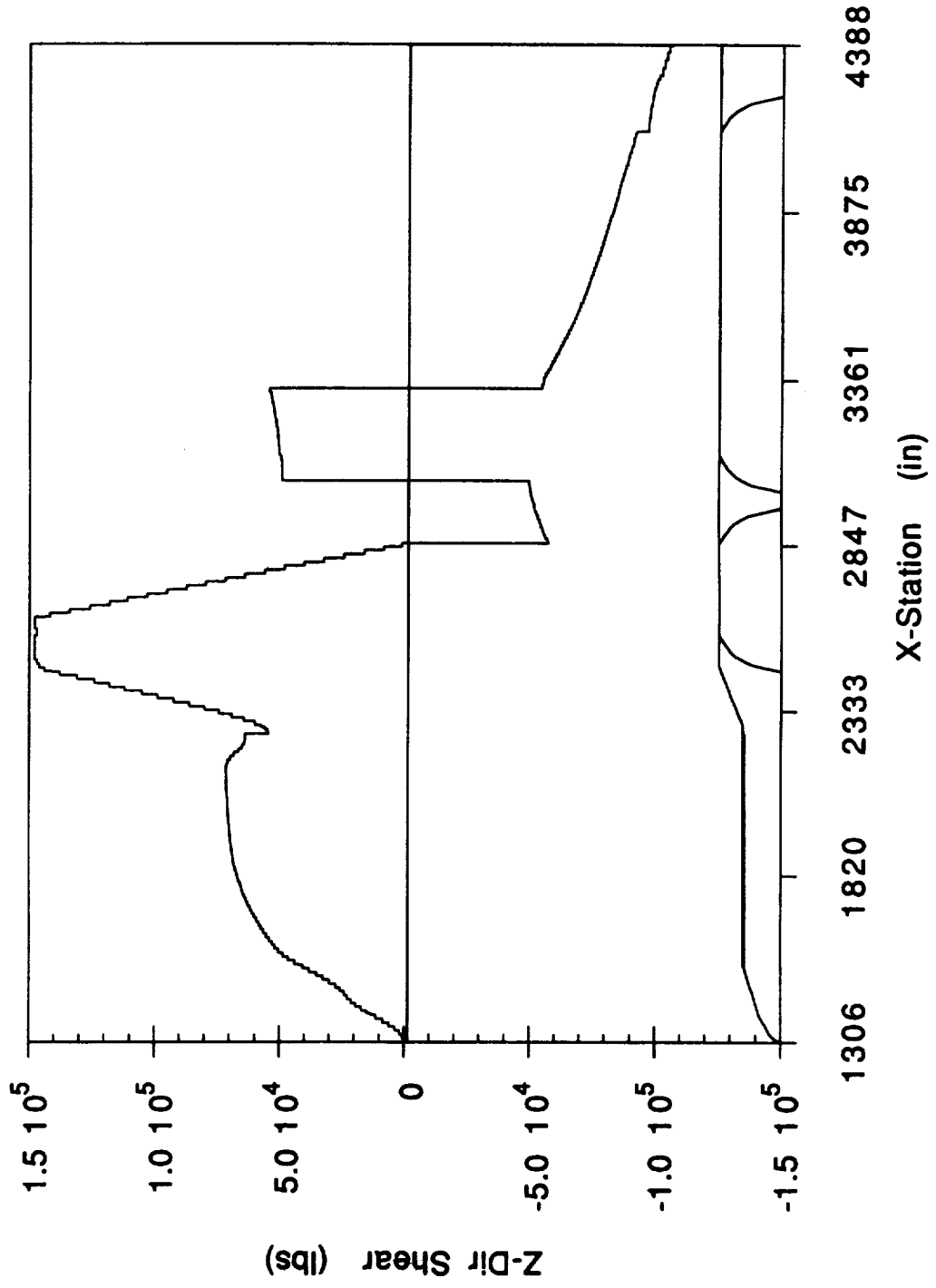

**NLS2 CORE - 9 km
Y-DIR MOMENT vs X-STATION**

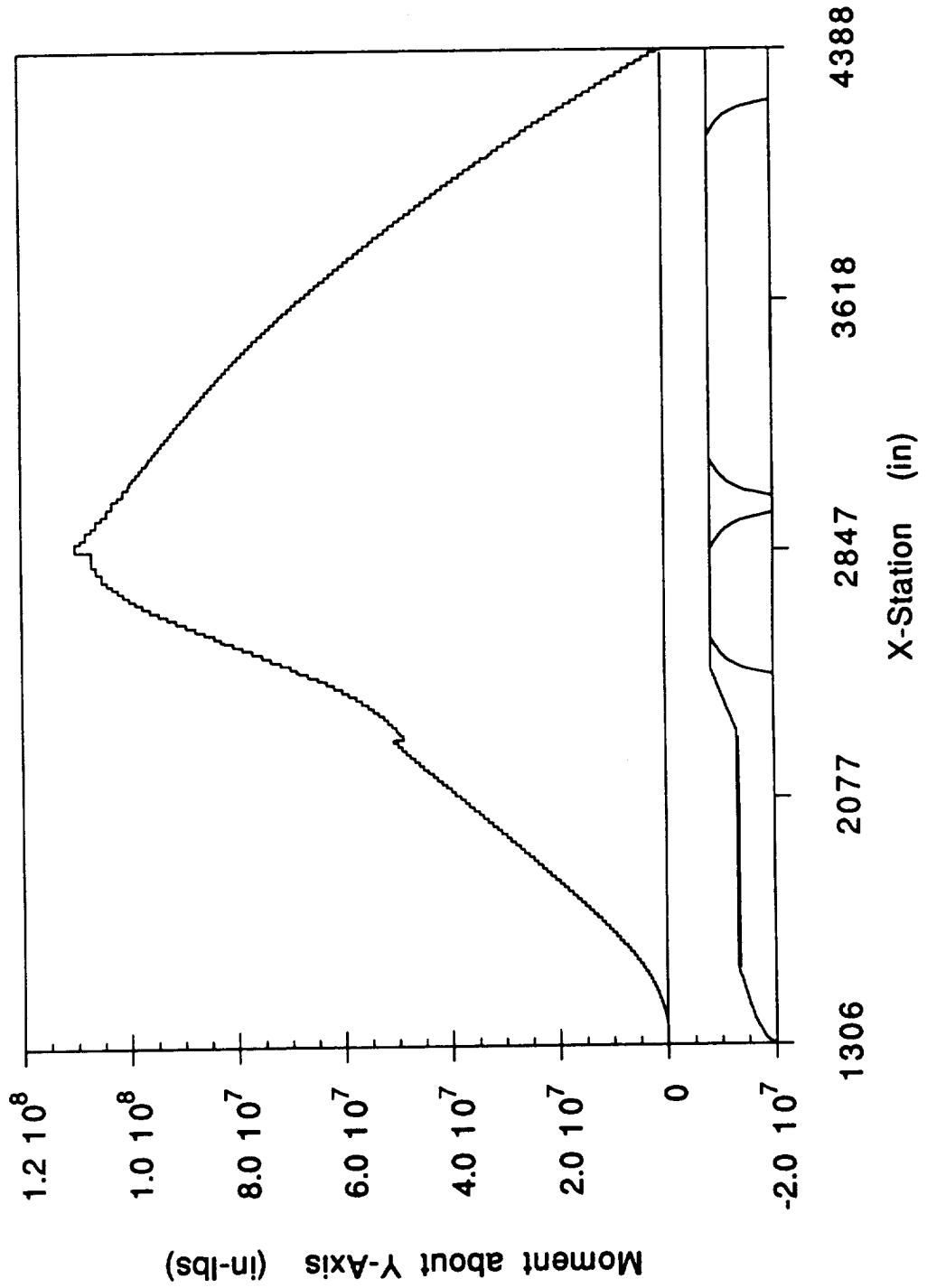

**NLS2 CORE - 9 km
Z-DIR MOMENT vs X-STATION**

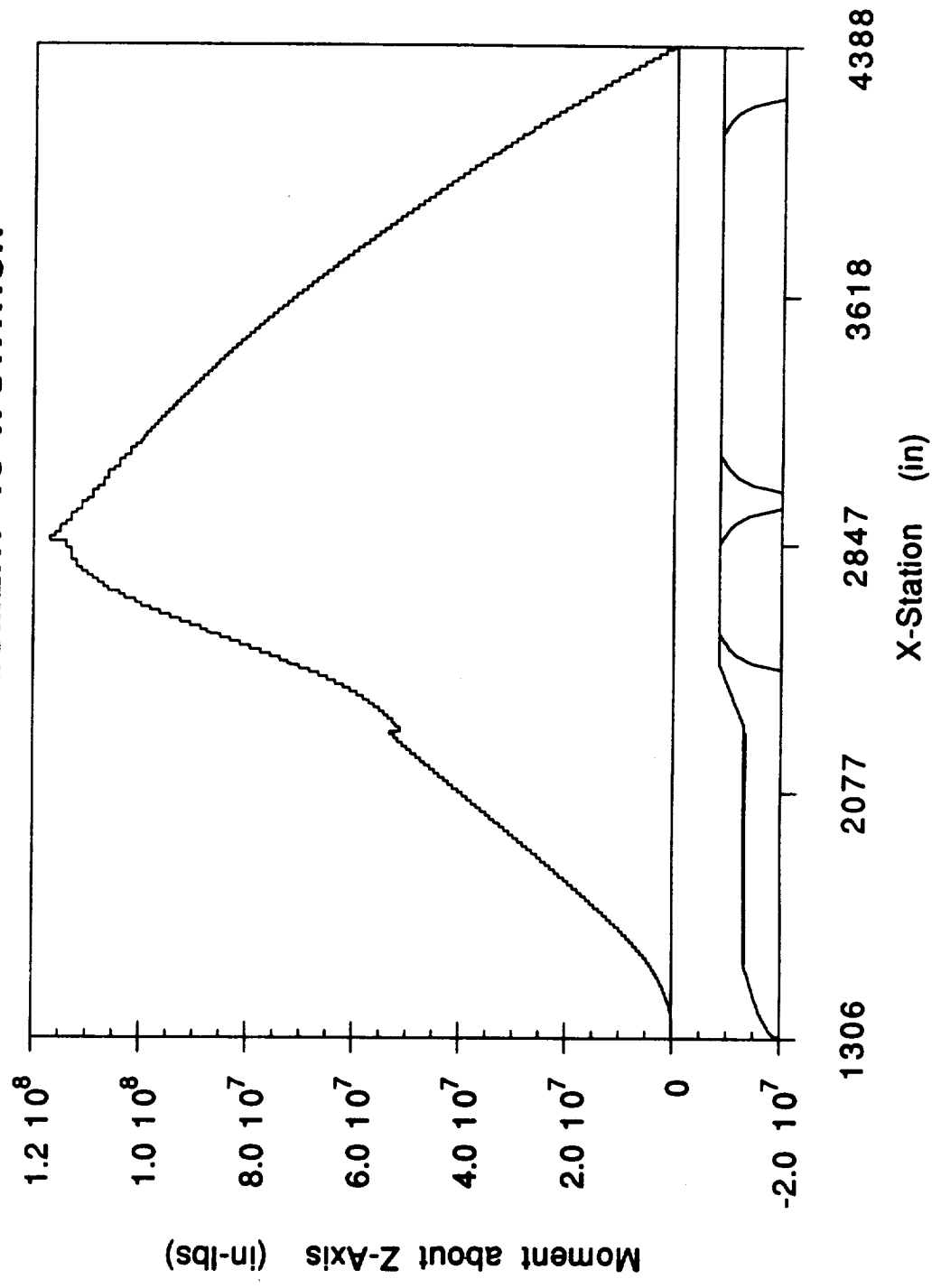

NLS2 CORE 9 km P EQUIVALENT vs X-STATION

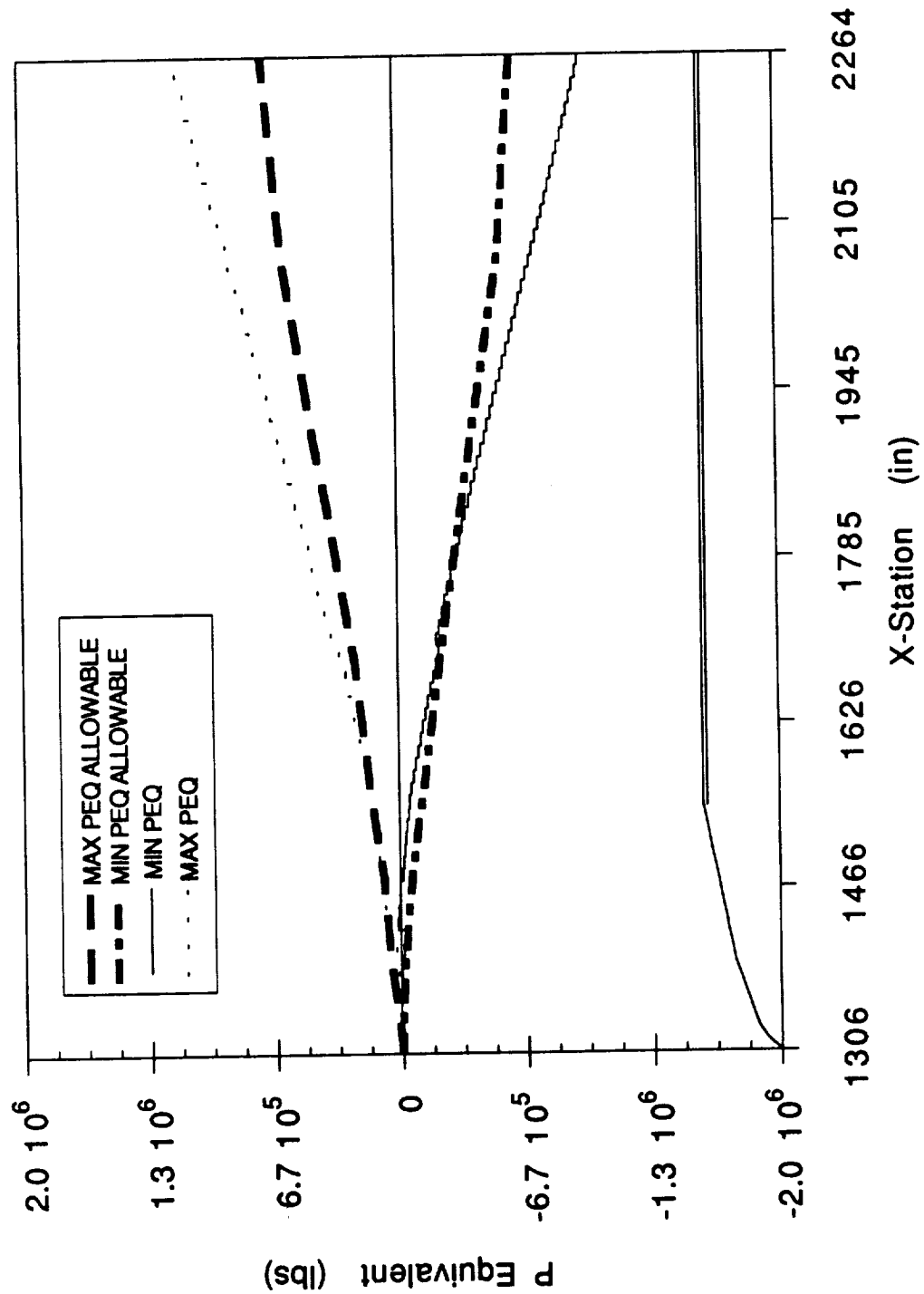

**NLS2 CORE 9 km
V EQUIVALENT vs X-STATION**

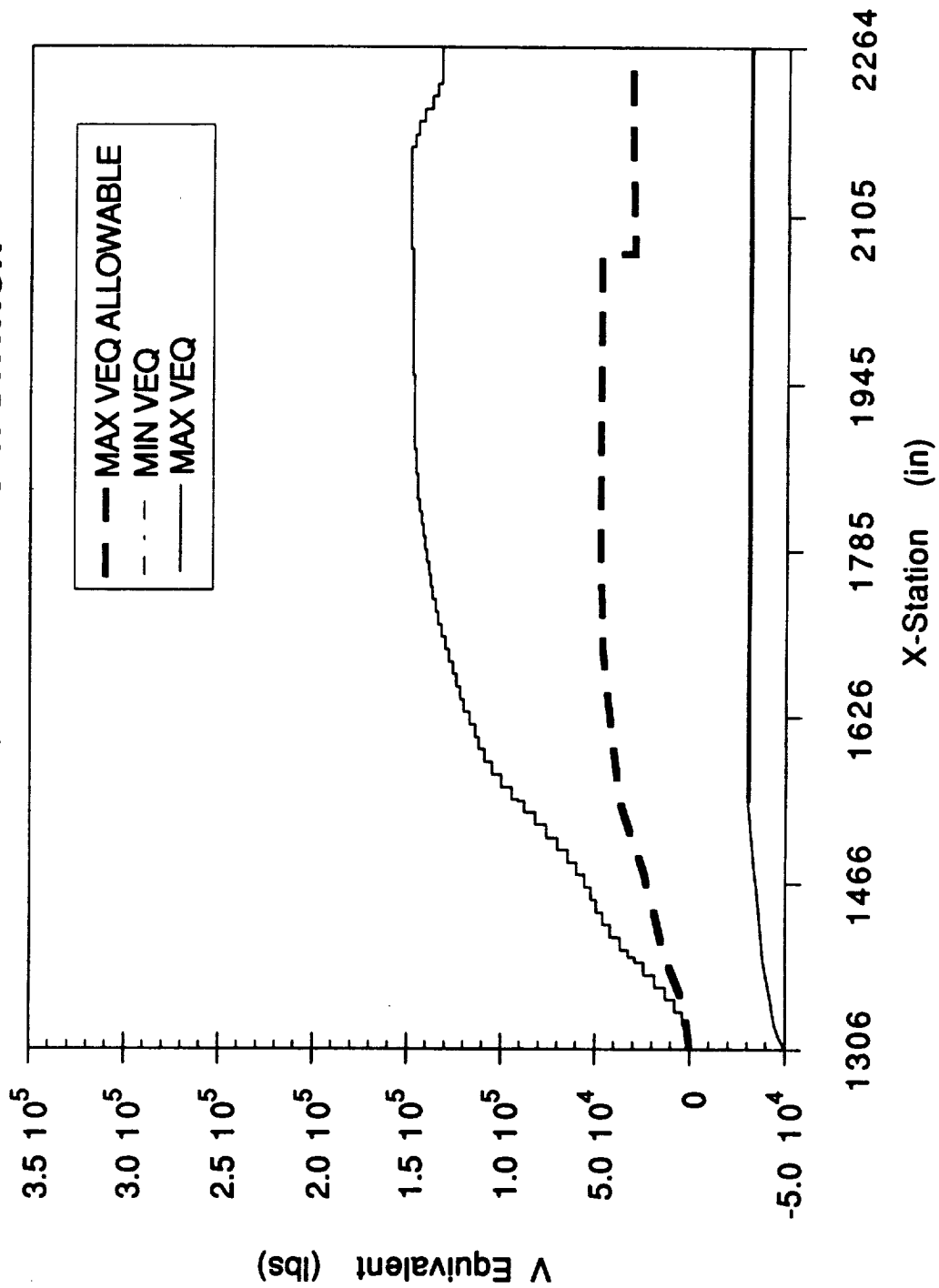

**NLS2 CORE - 10 km
NX vs X-STATION**

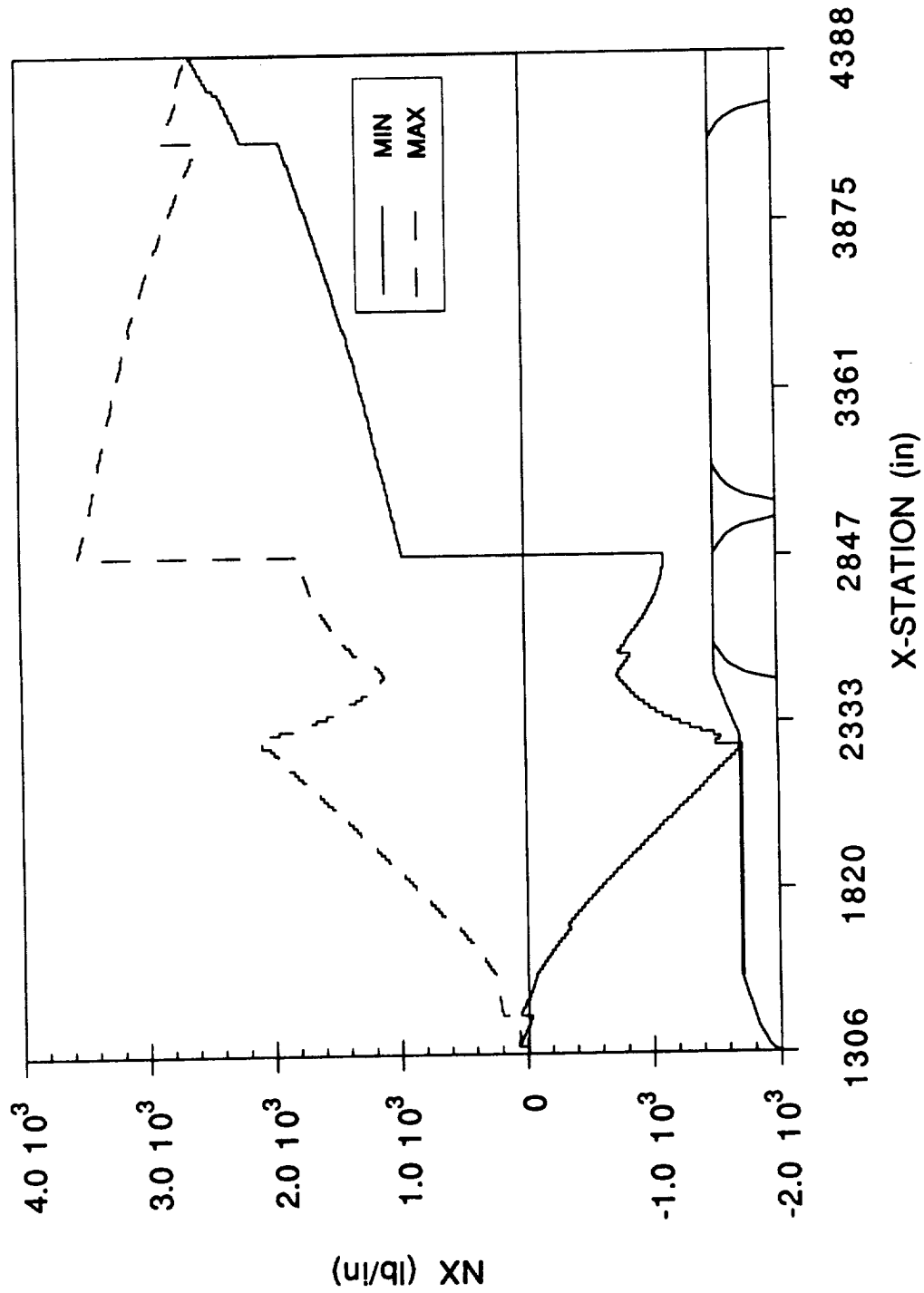

NLS2 CORE - 10 km NV vs X-STATION

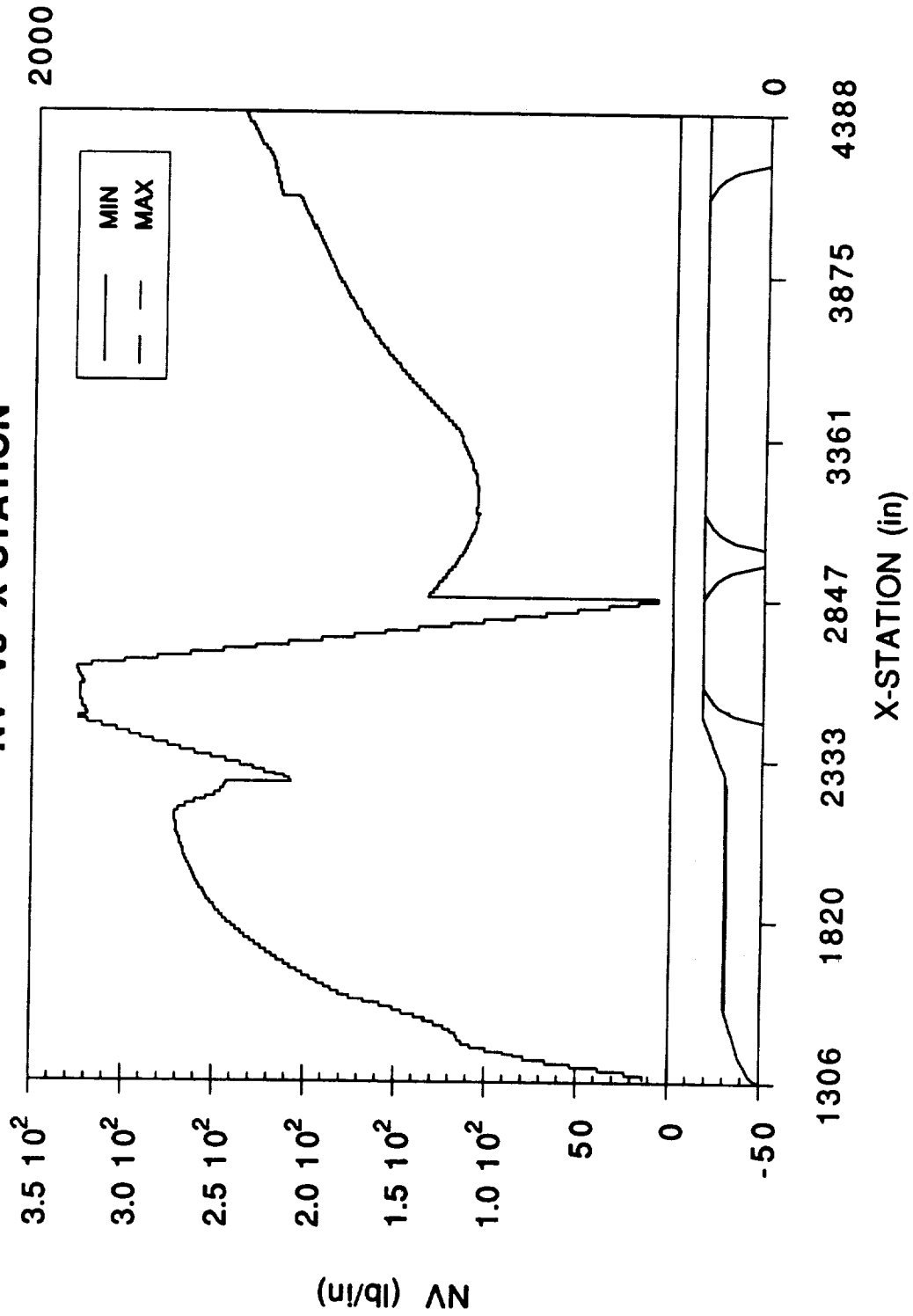

((

**NLS2 CORE - 10 km
AXIAL SHEAR vs X-STATION**

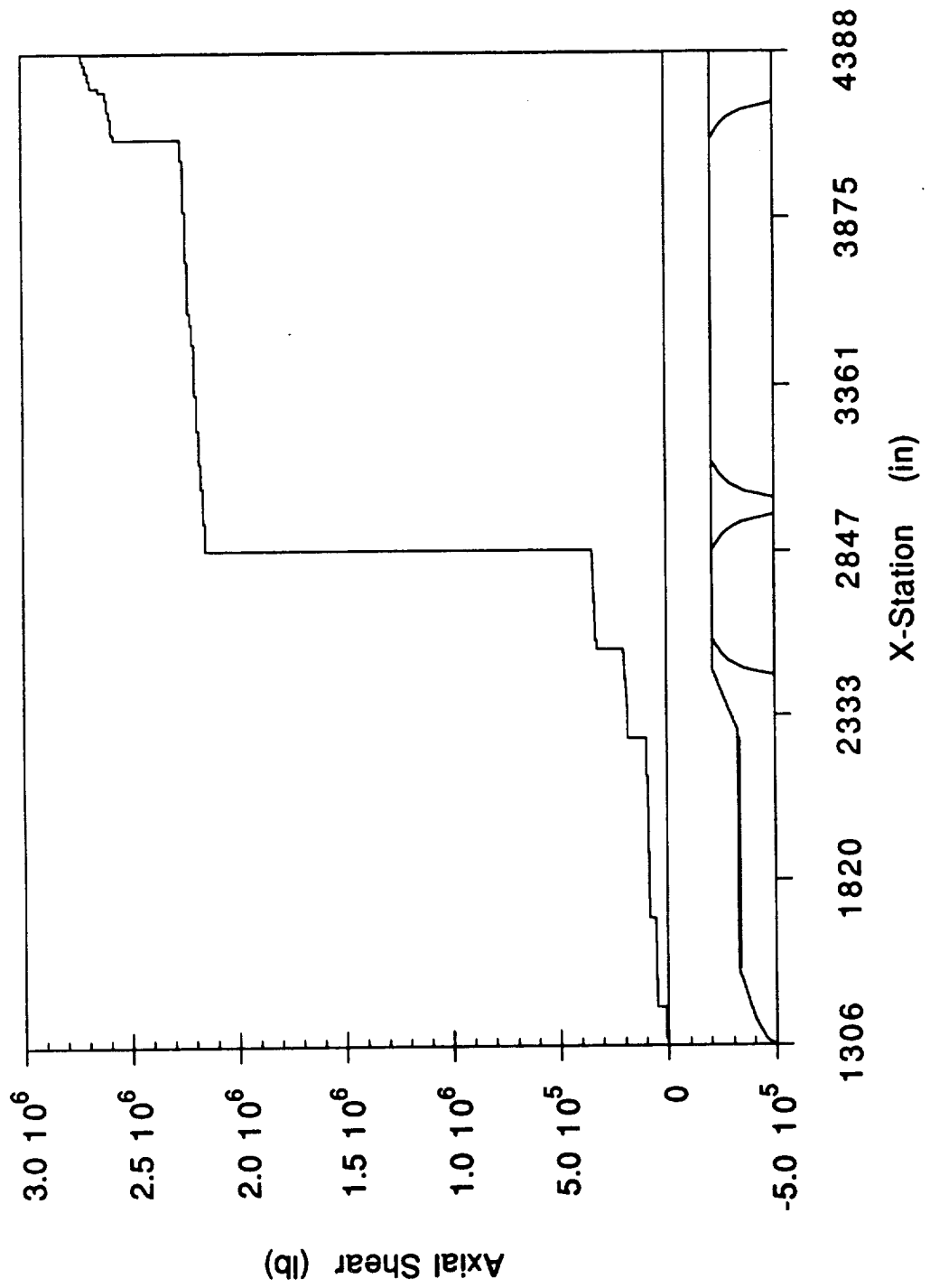

**NLS2 CORE - 10 km
Y-DIR SHEAR VS X-STATION**

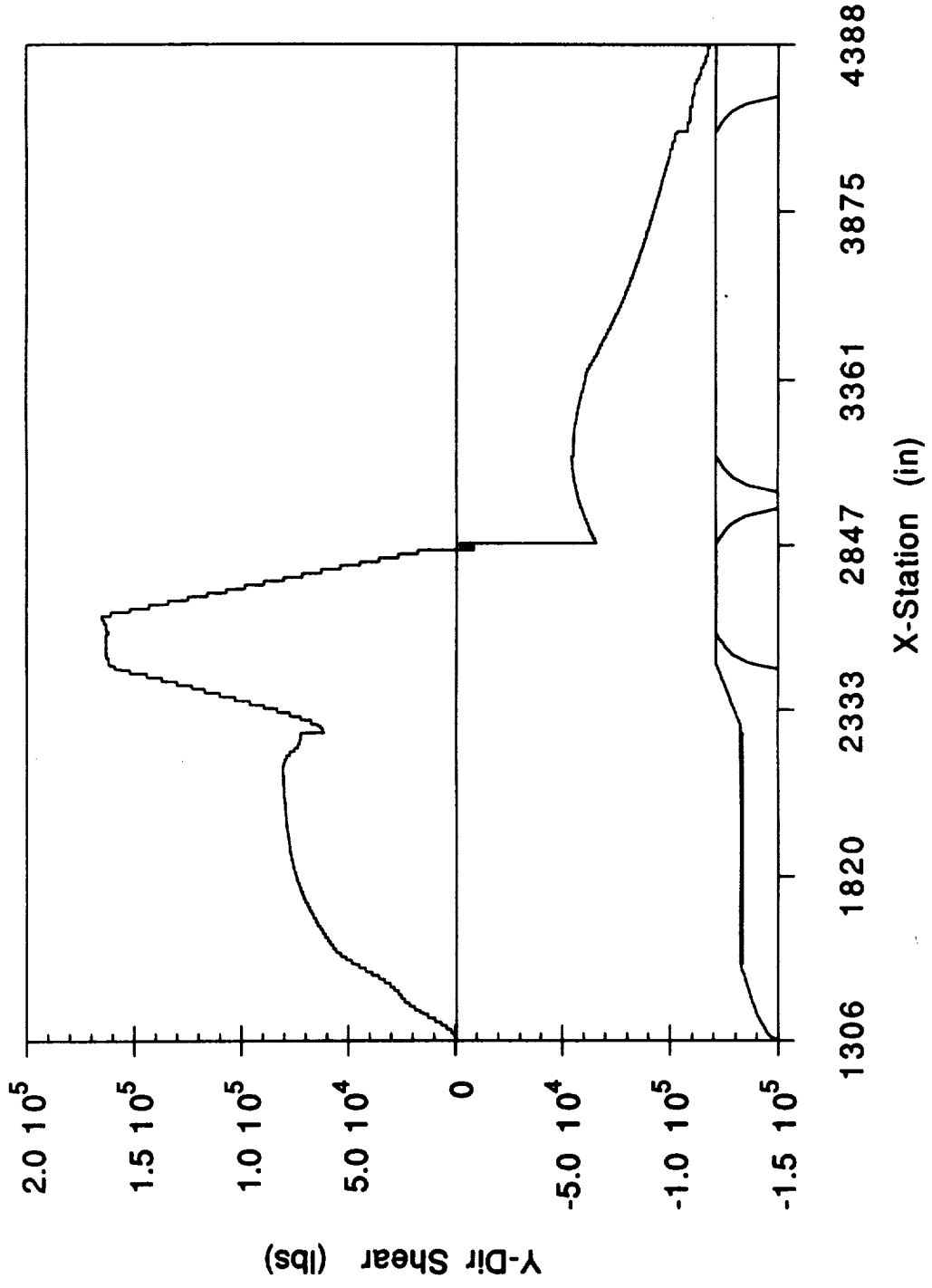

**NLS2 CORE - 10 km
Z-DIR SHEAR VS X-STATION**

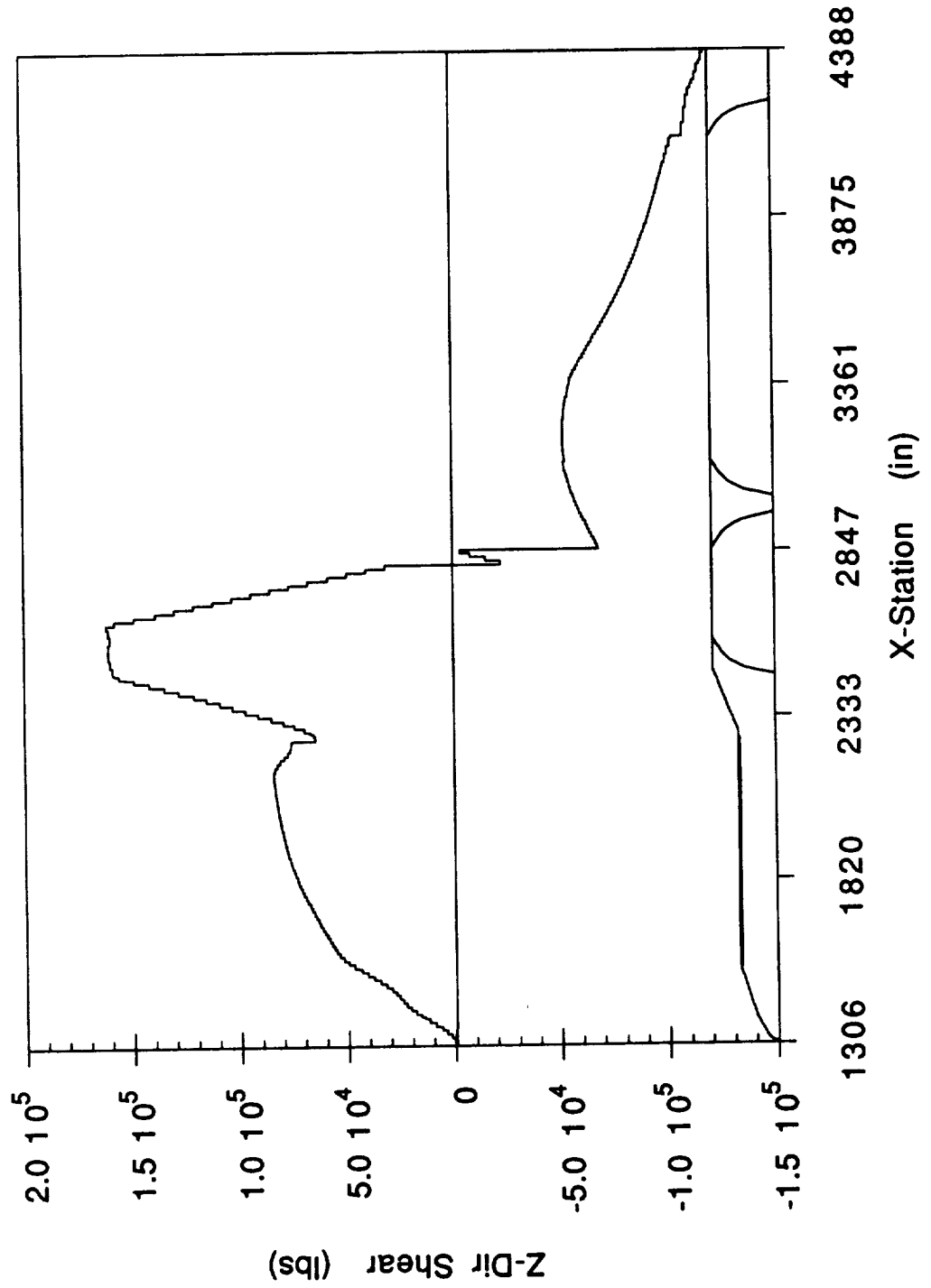

**NLS2 CORE - 10 km
Y-DIR MOMENT vs X-STATION**

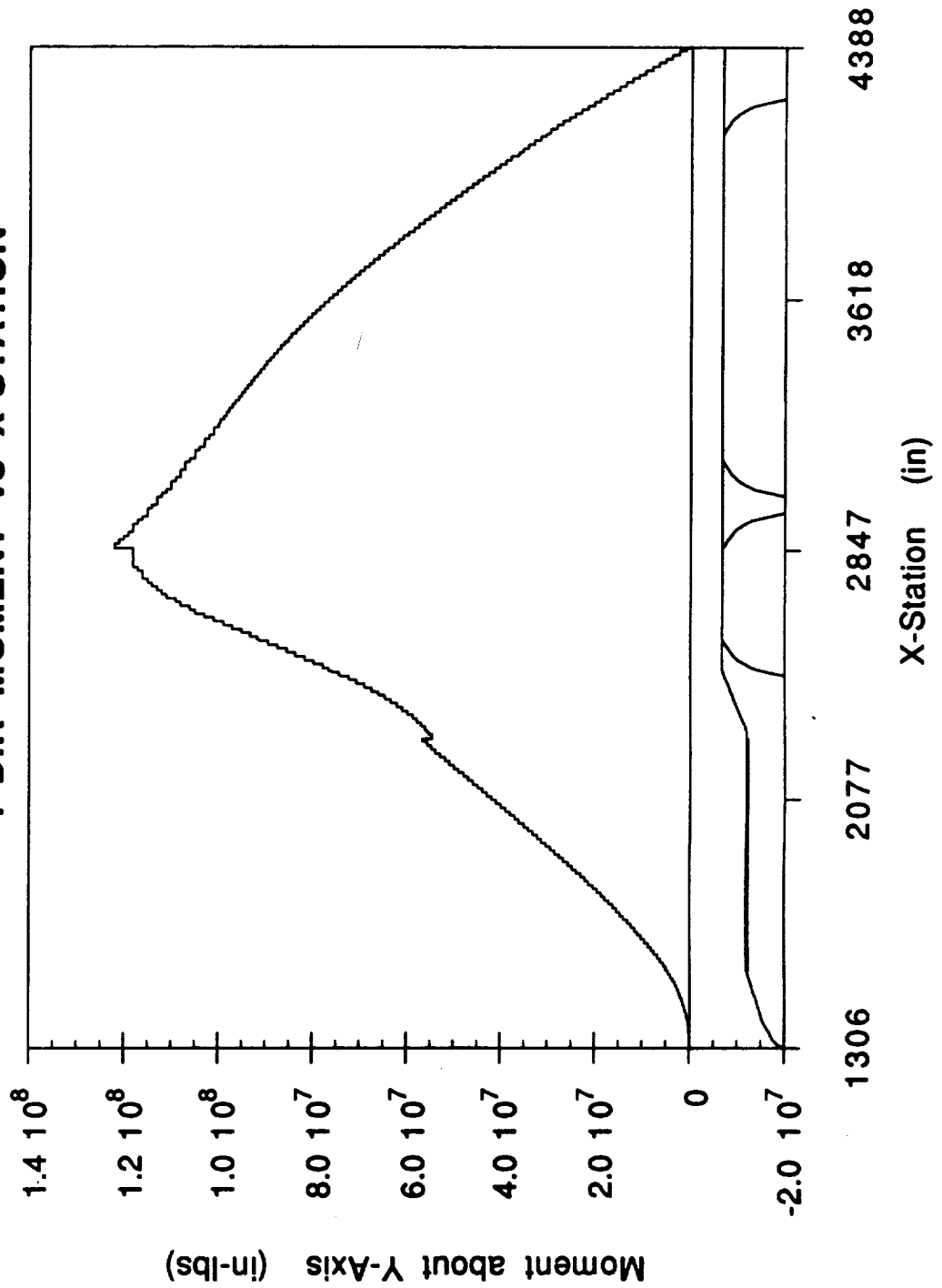

**NLS2 CORE - 10 km
Z-DIR MOMENT vs X-STATION**

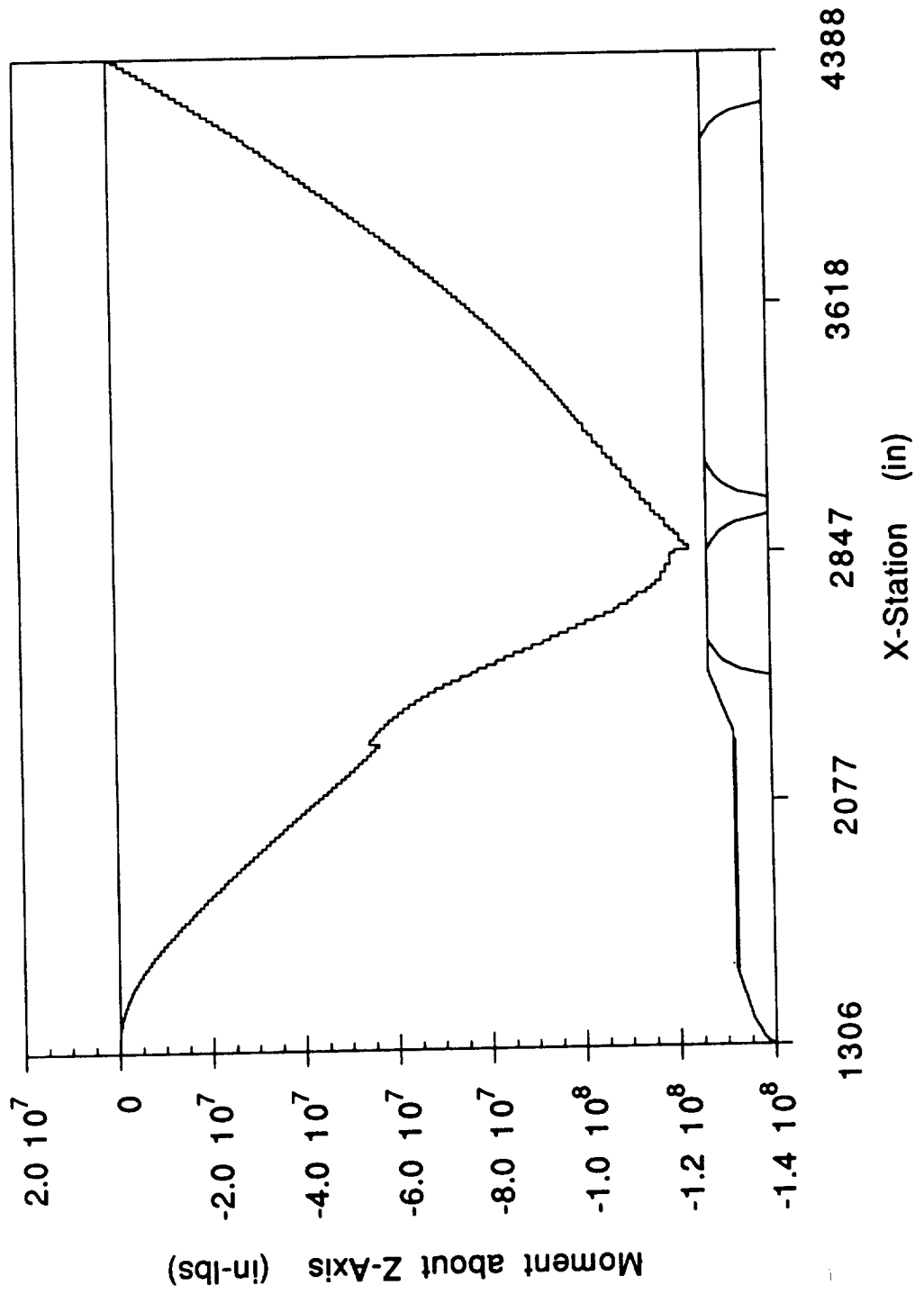

**NLS2 CORE 10 km
P EQUIVALENT vs X-STATION**

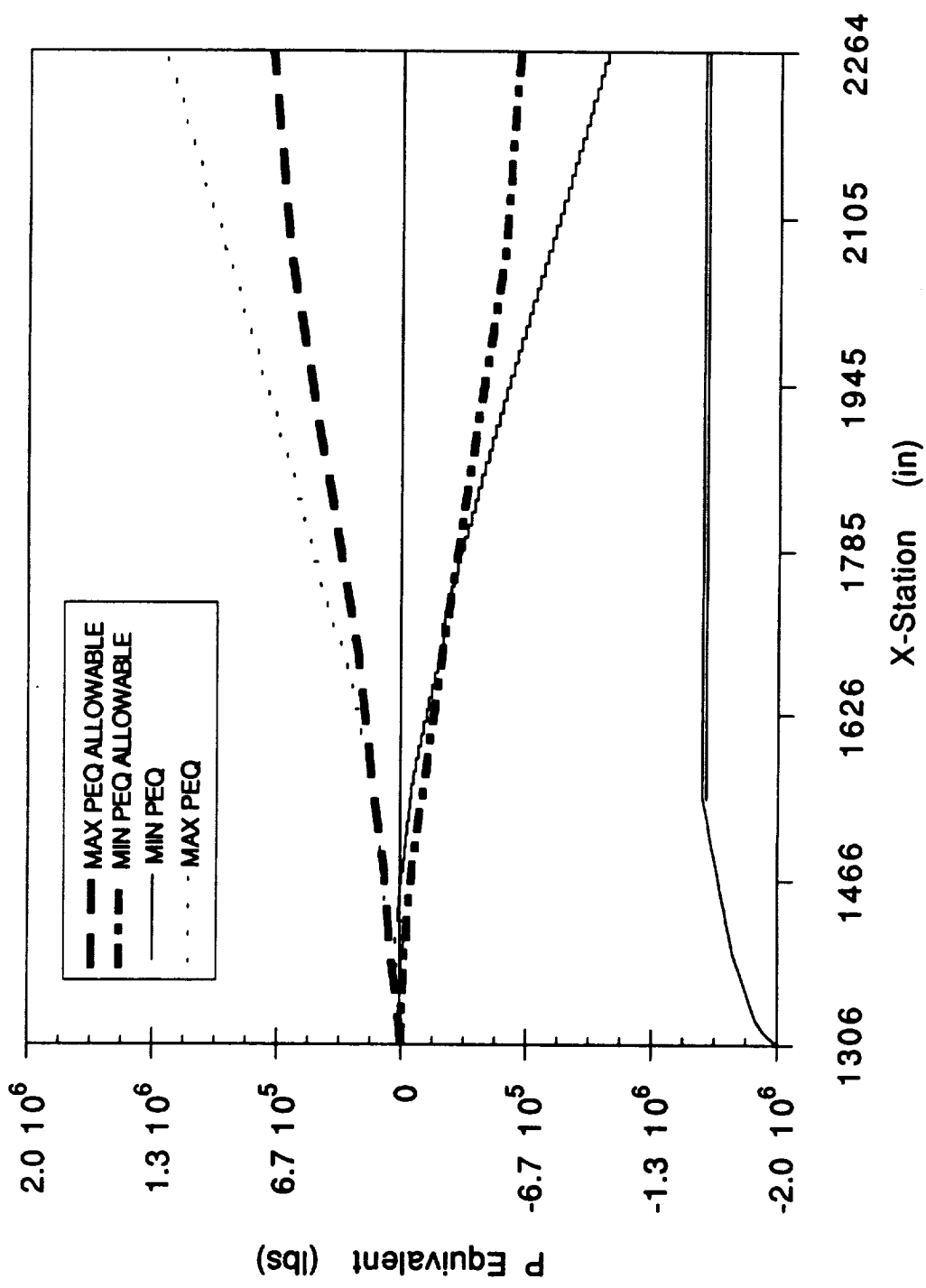

**NLS2 CORE 10 km
V EQUIVALENT vs X-STATION**

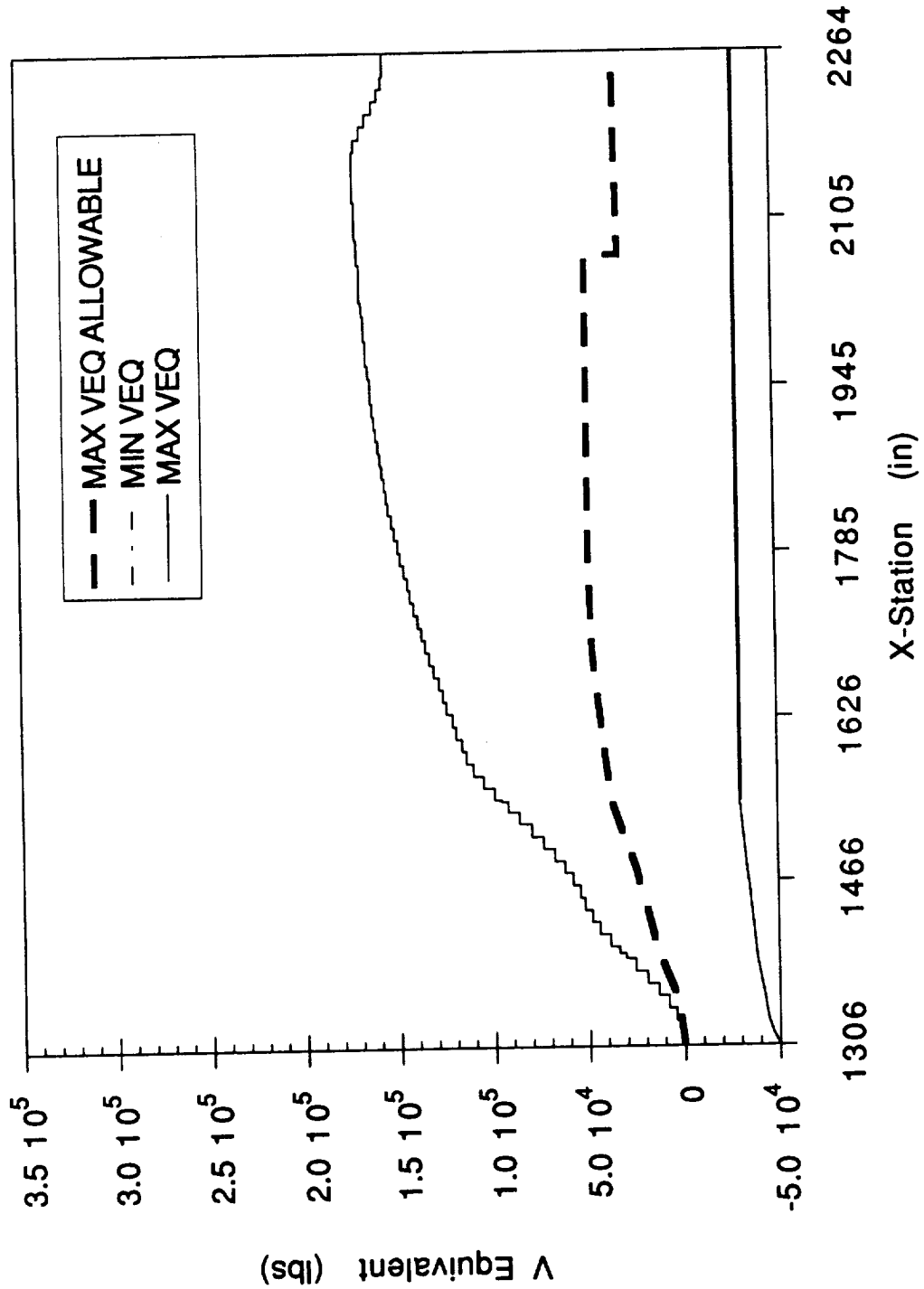

NLS2 CORE - 11 km NX vs X-STATION

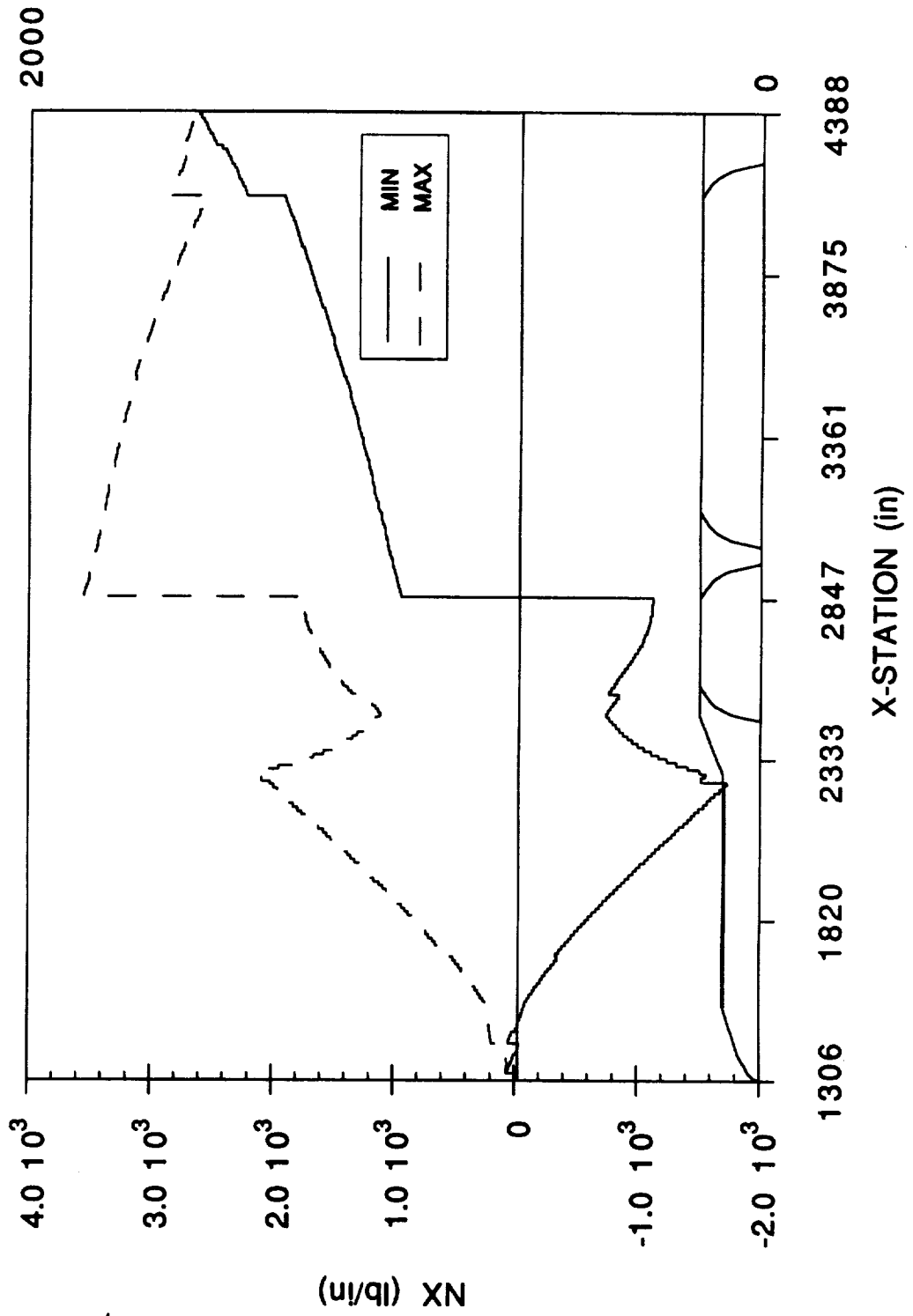

((

NLS2 CORE - 11 km
NV vs X-STATION

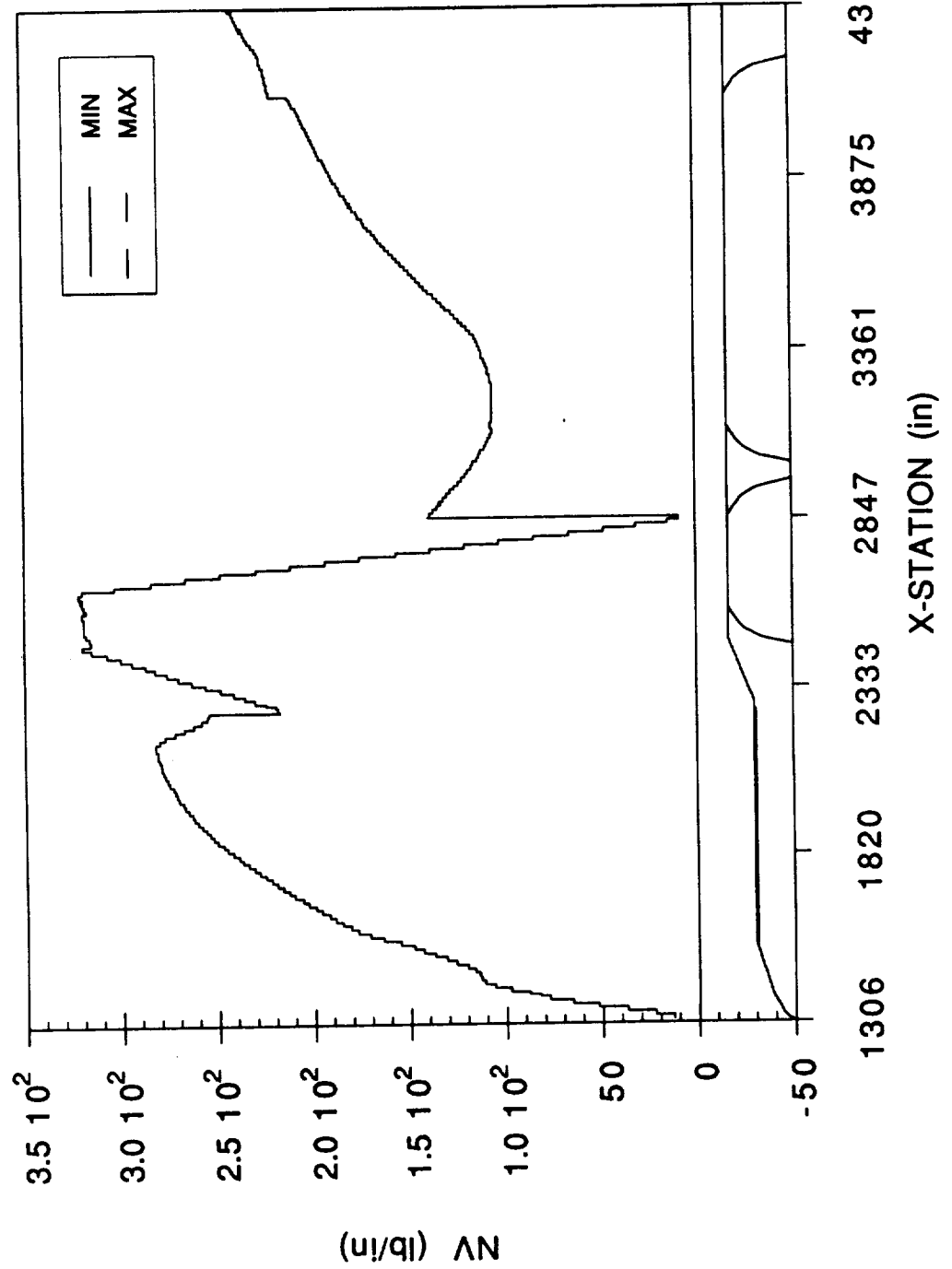

**NLS2 CORE - 11 km
AXIAL SHEAR vs X-STATION**

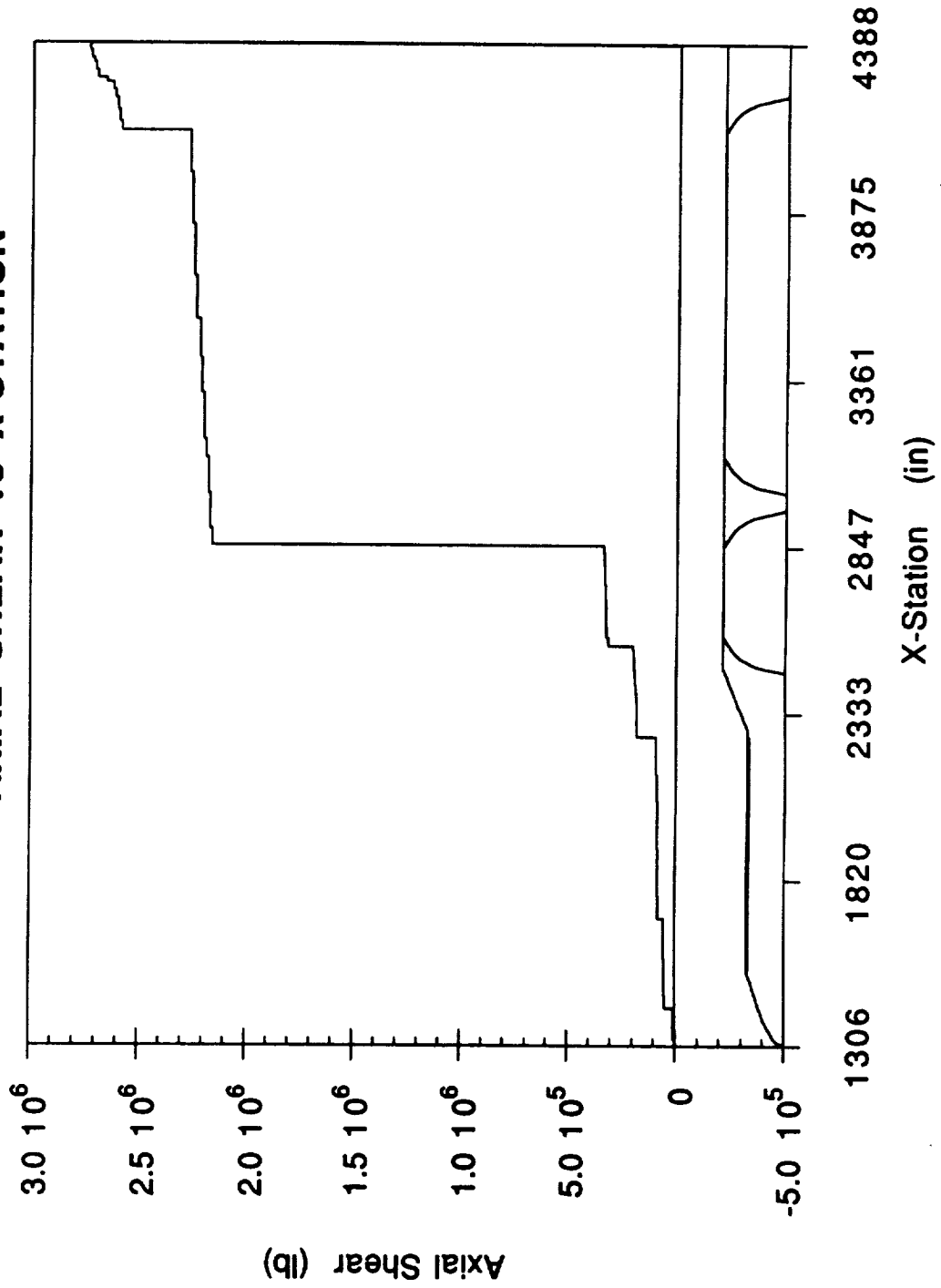

**NLS2 CORE - 11 km
Y-DIR SHEAR vs X-STATION**

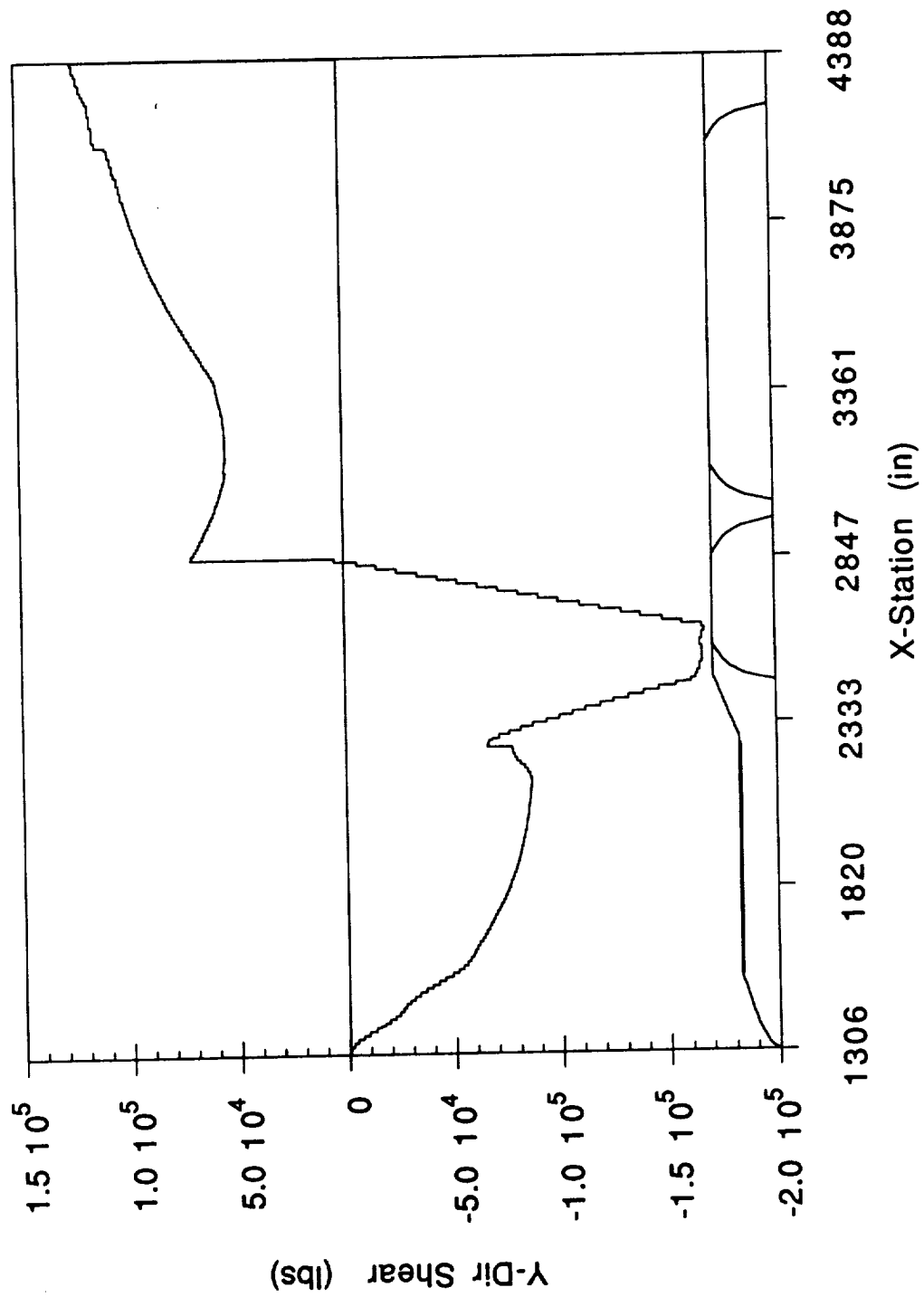

NLS2 CORE - 11 km
Z-DIR SHEAR vs X-STATION

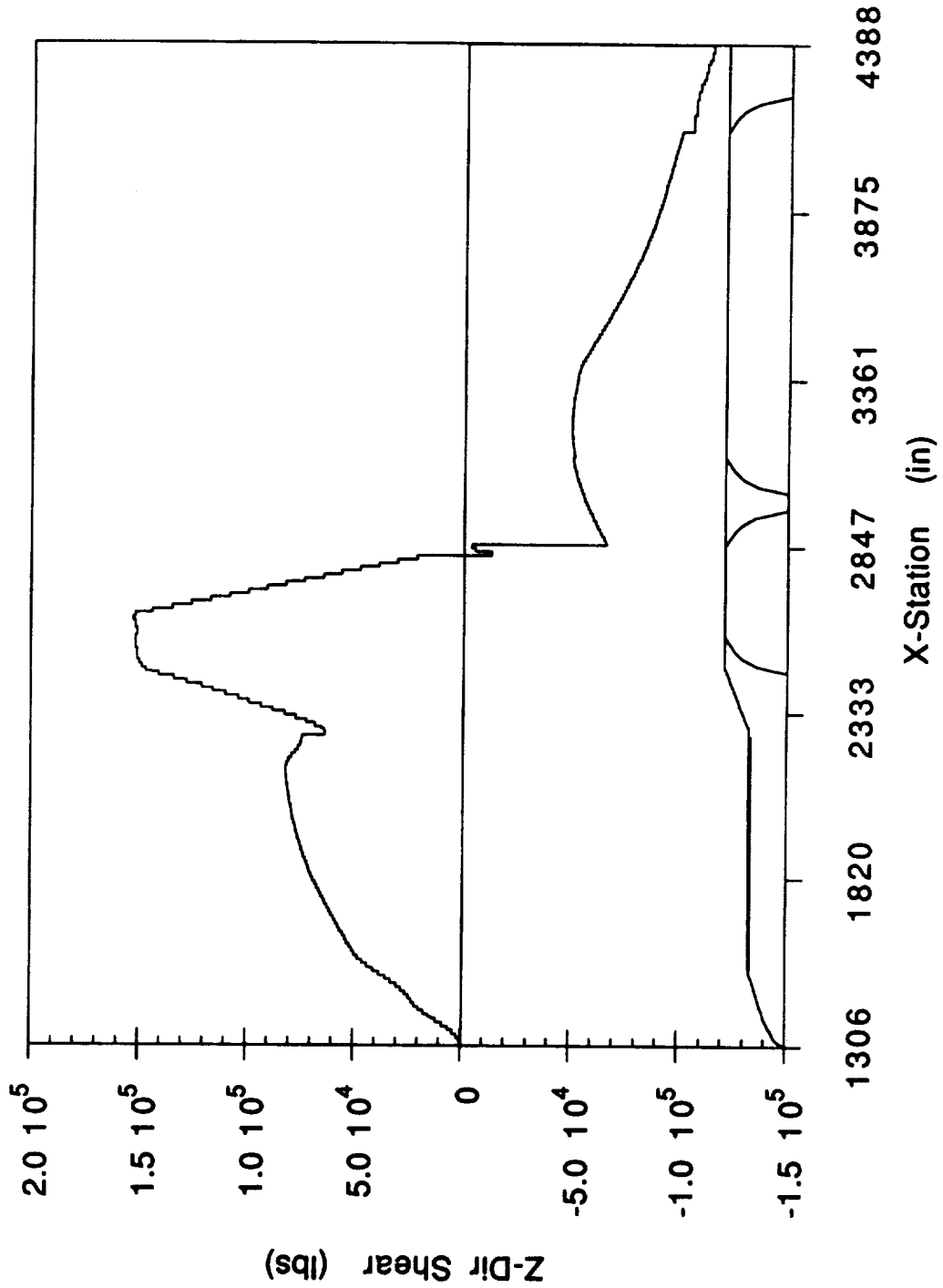

**NLS2 CORE - 11 km
Y-DIR MOMENT vs X-STATION**

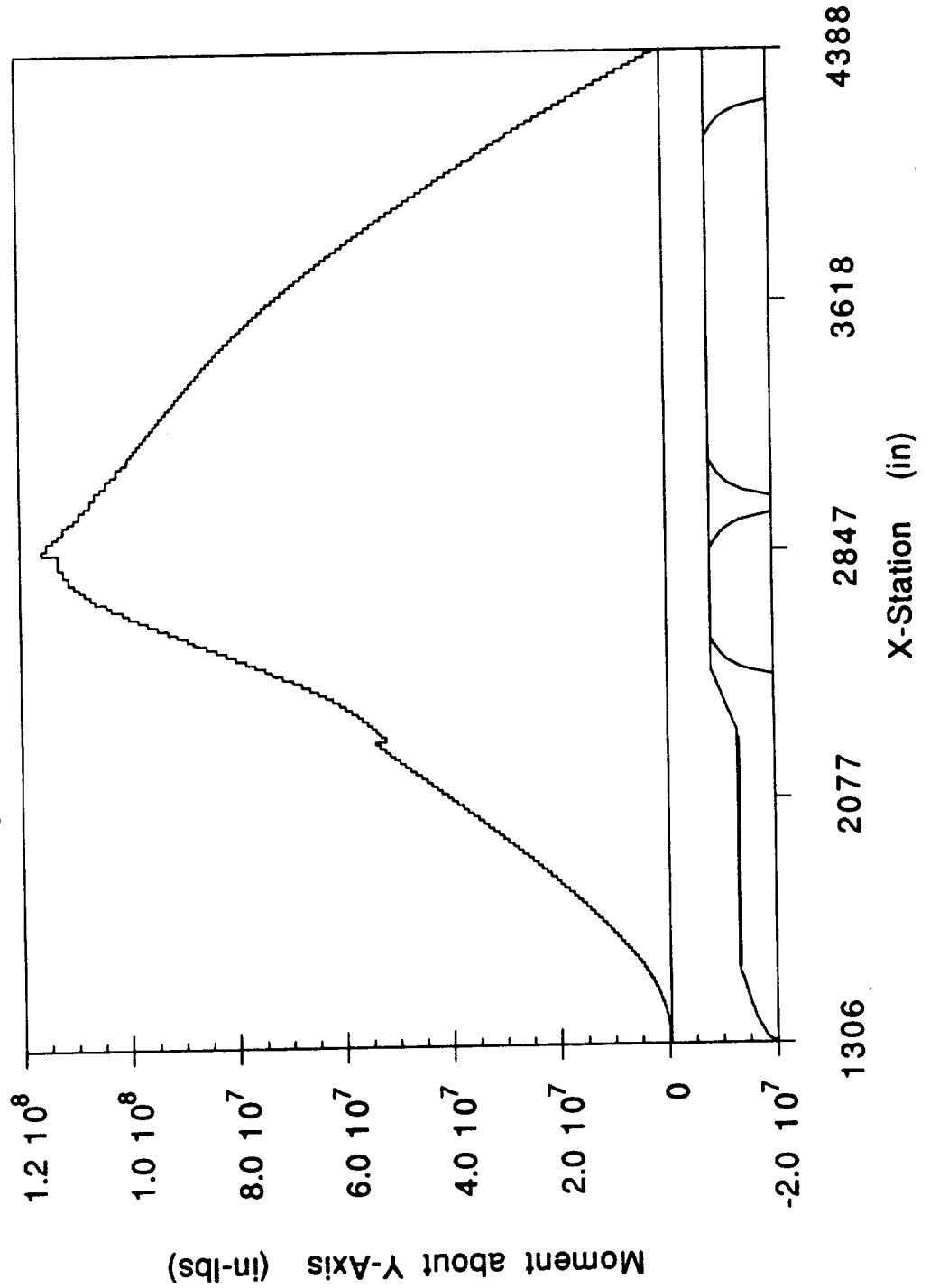

NLS2 CORE - 11 km Z-DIR MOMENT vs X-STATION

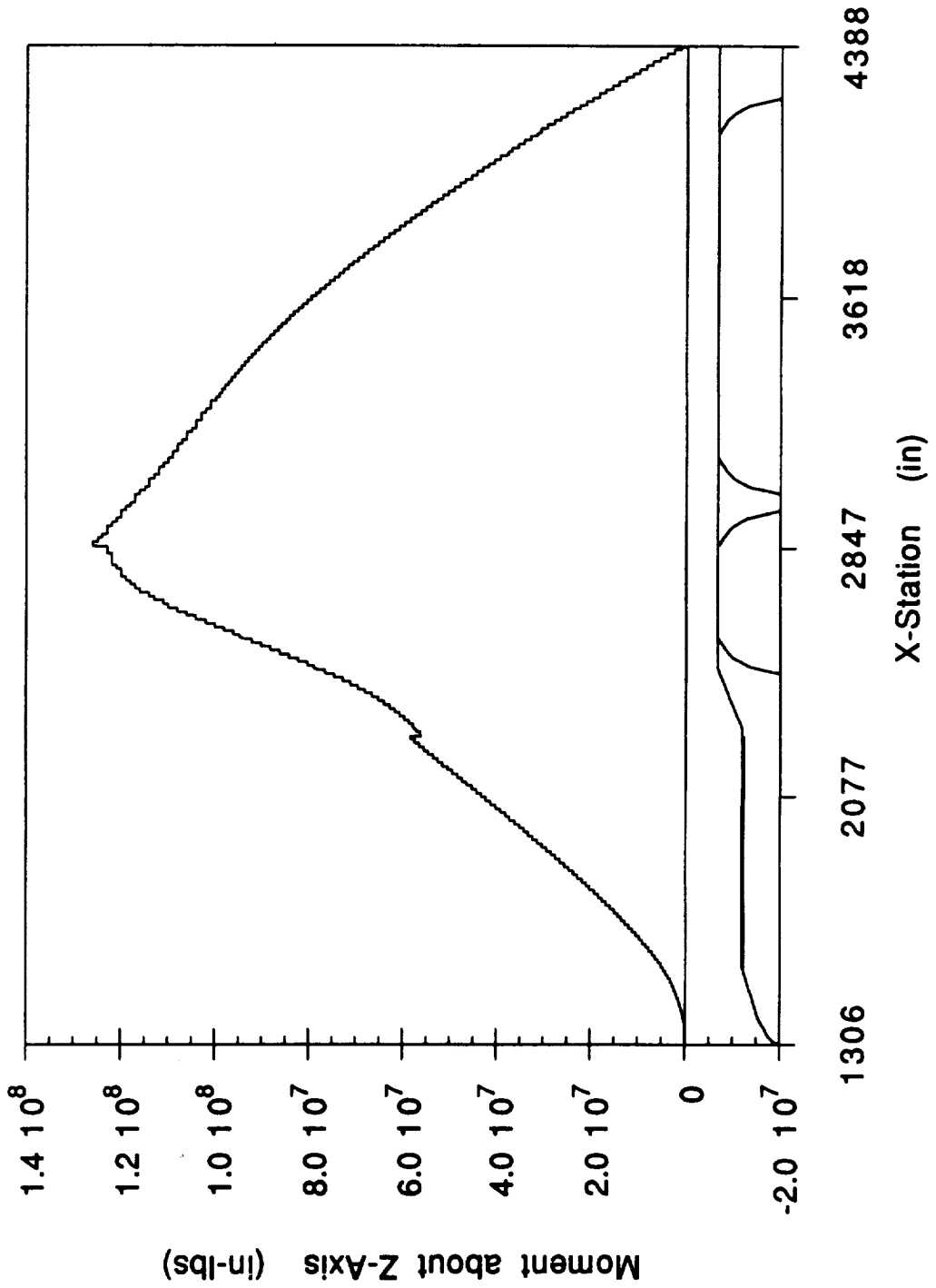

(((

**NLS2 CORE 11 km
P EQUIVALENT vs X-STATION**

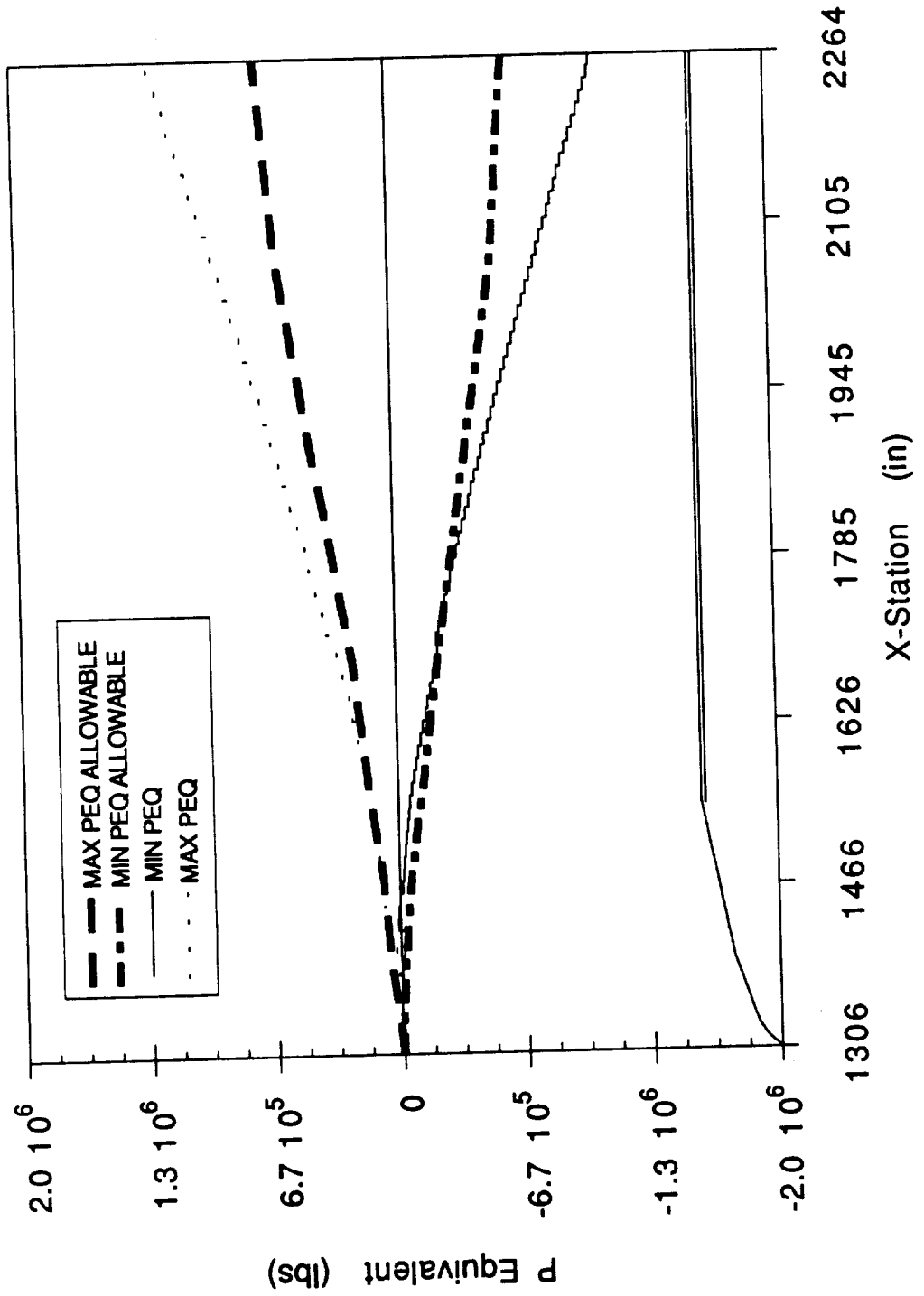

**NLS2 CORE 11 km
V EQUIVALENT vs X-STATION**

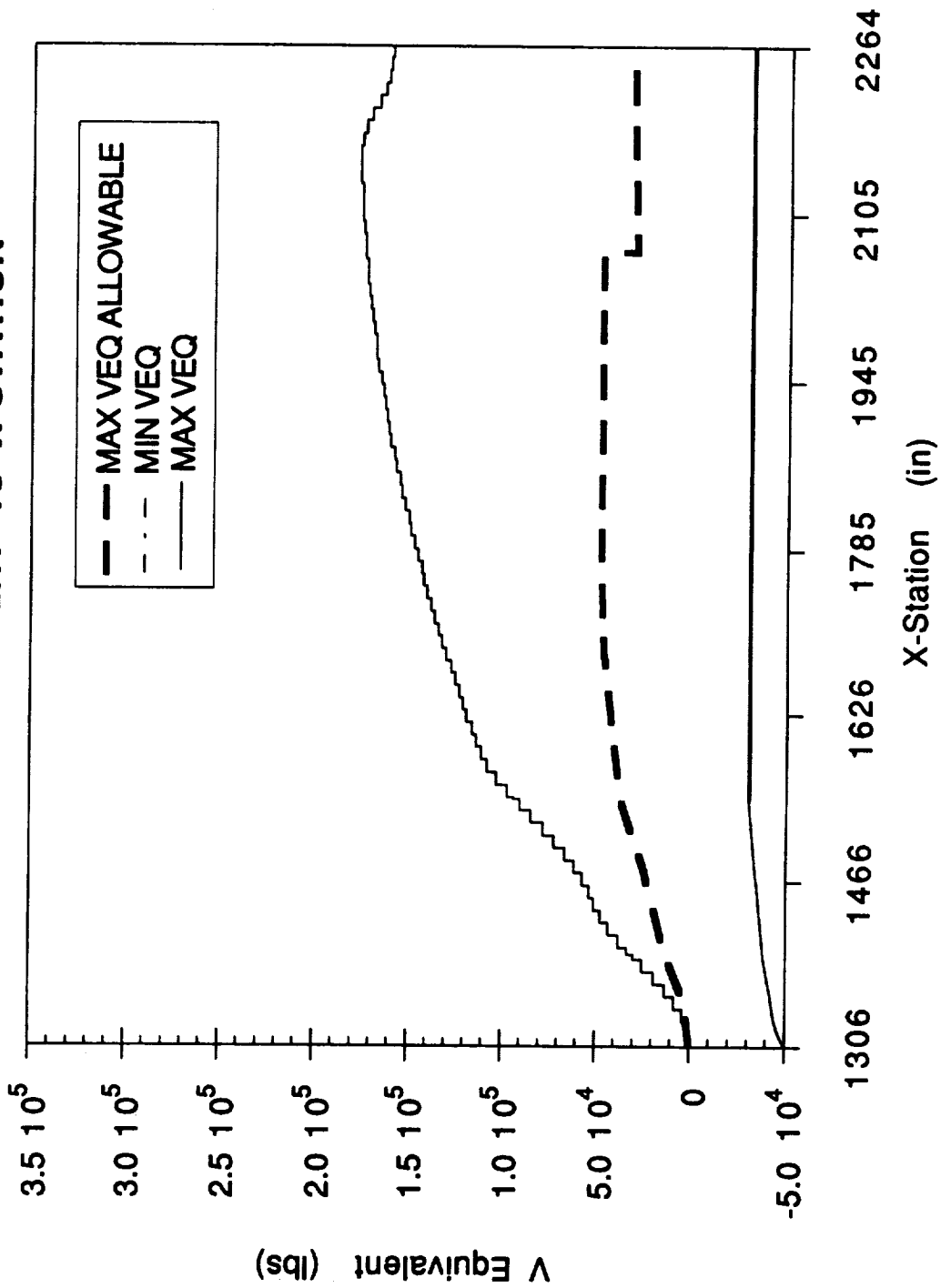

**NLS2 CORE - 12 km
NX vs X-STATION**

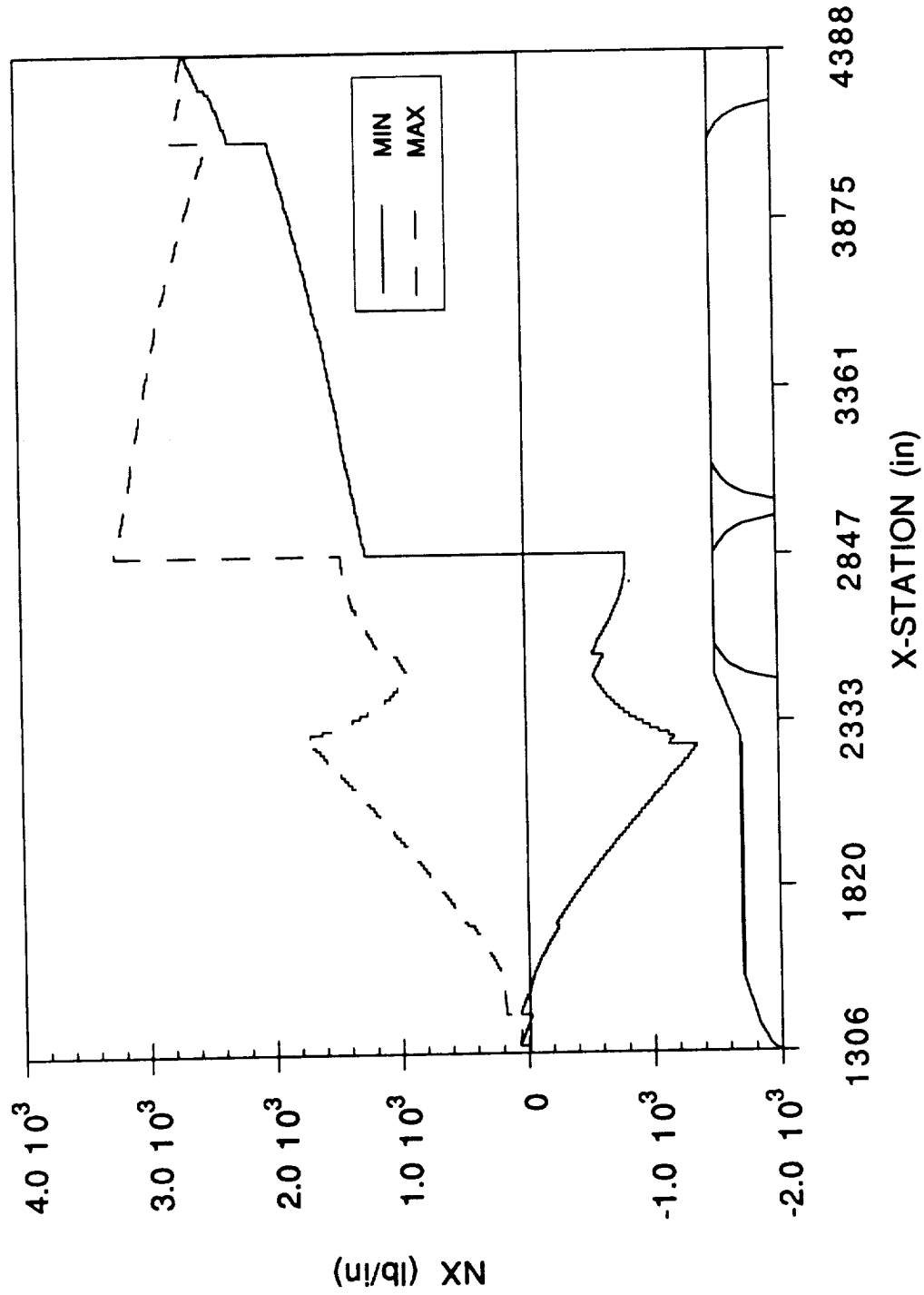

NLS2 CORE - 12 km NV vs X-STATION

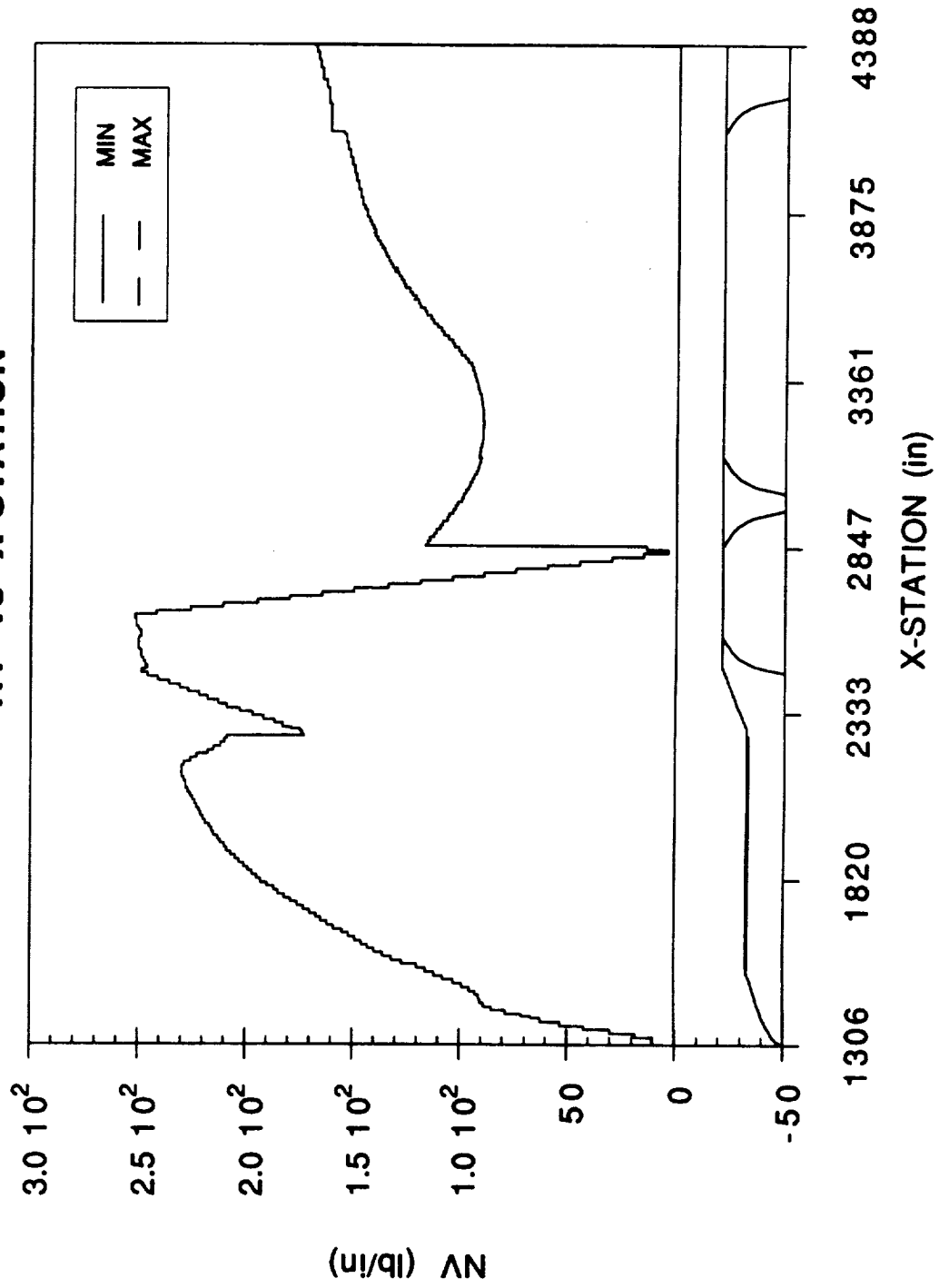

(((

**NLS2 CORE - 12 km
AXIAL SHEAR vs X-STATION**

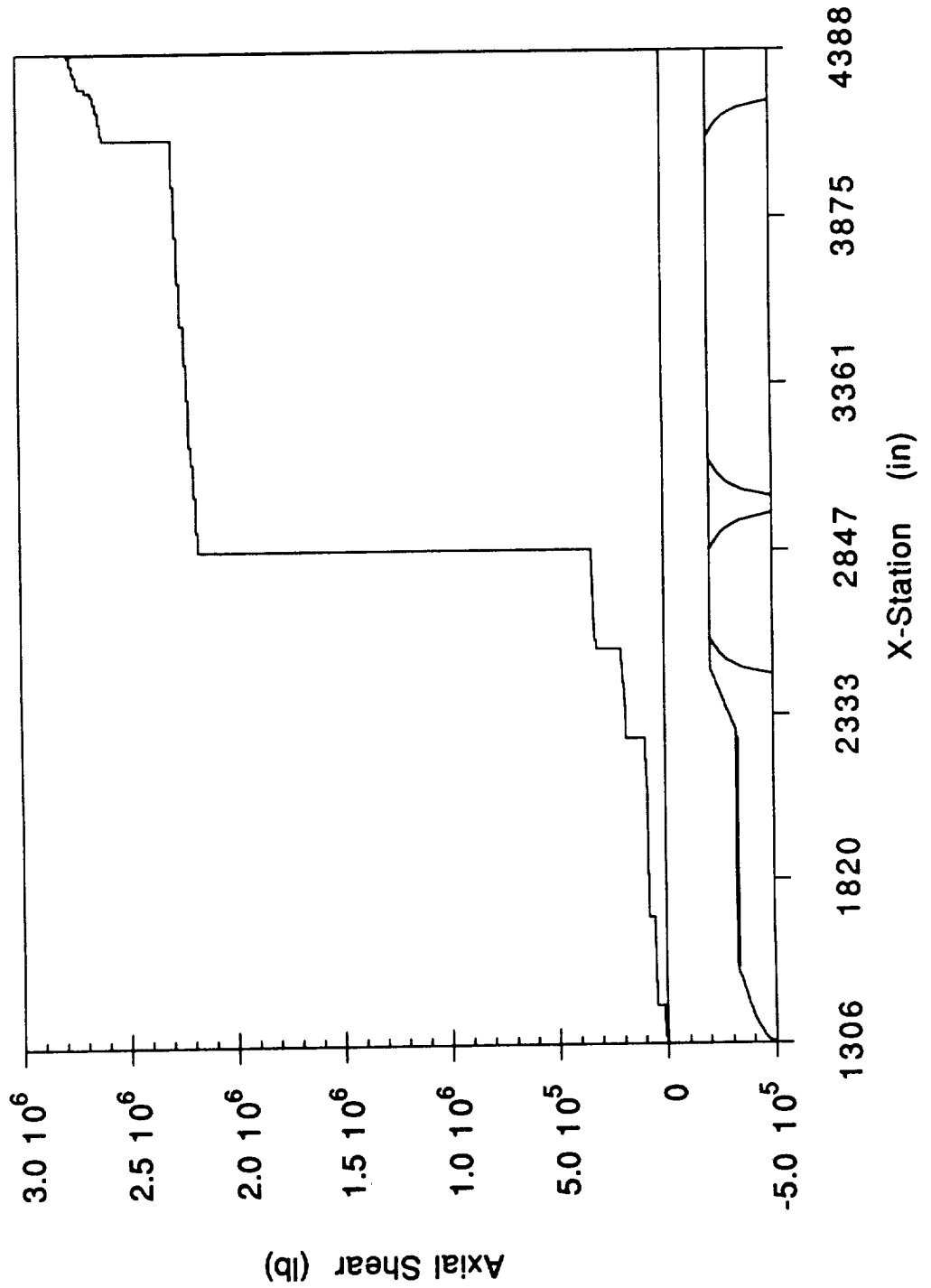

NLS2 CORE - 12 km
Y-DIR SHEAR vs X-STATION

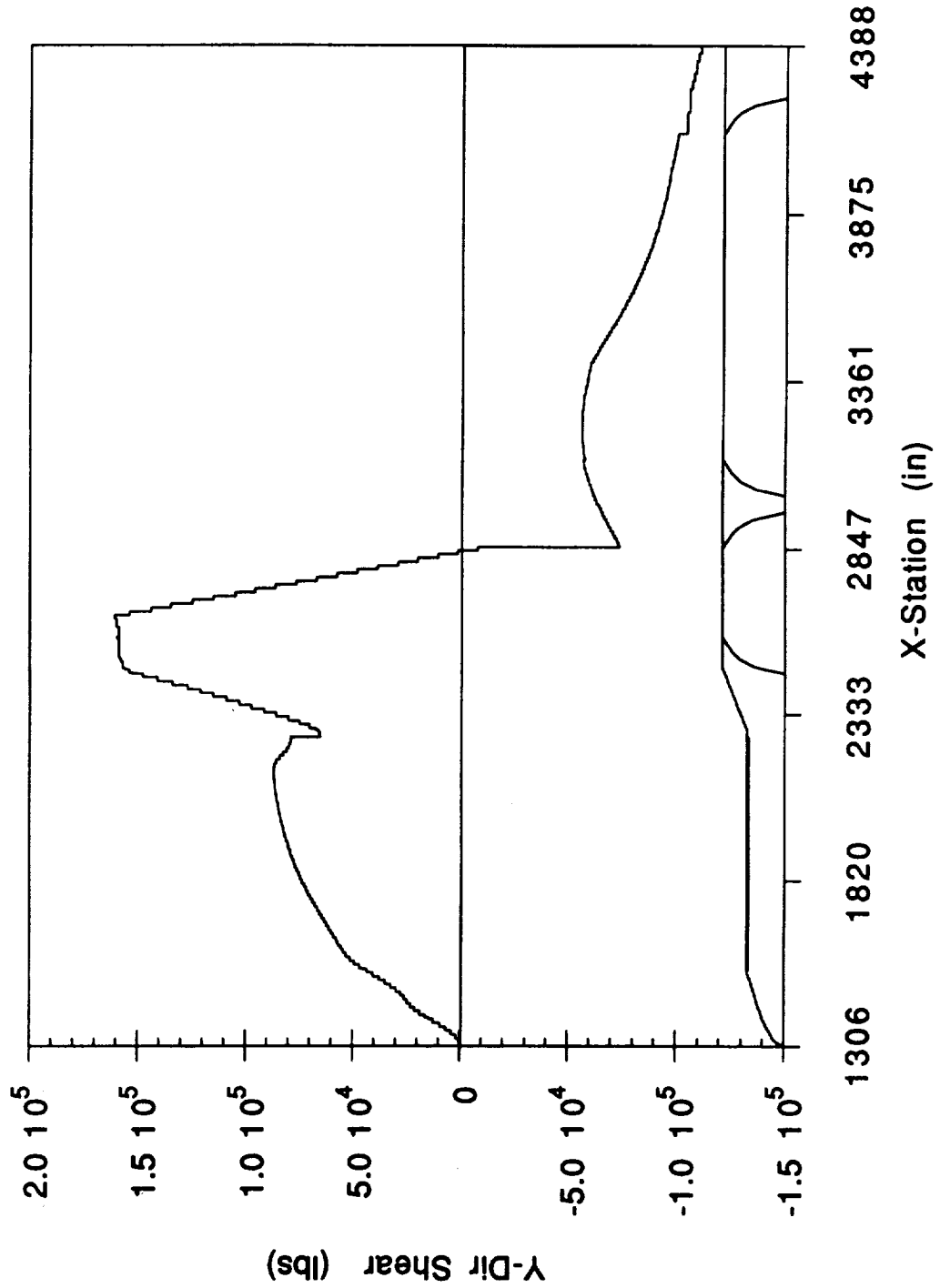

**NLS2 CORE - 12 km
Z-DIR SHEAR vs X-STATION**

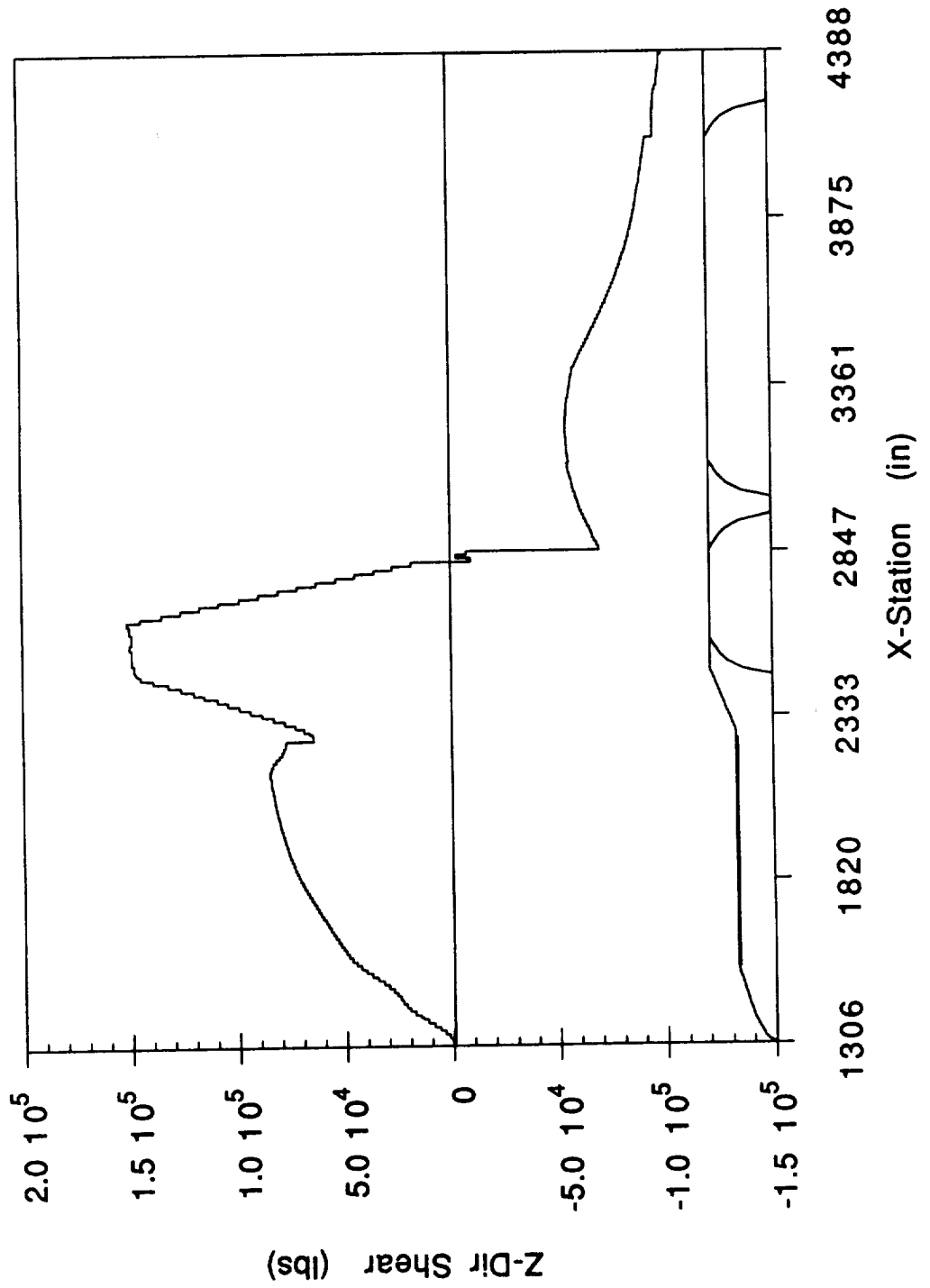

NLS2 CORE - 12 km Y-DIR MOMENT vs X-STATION

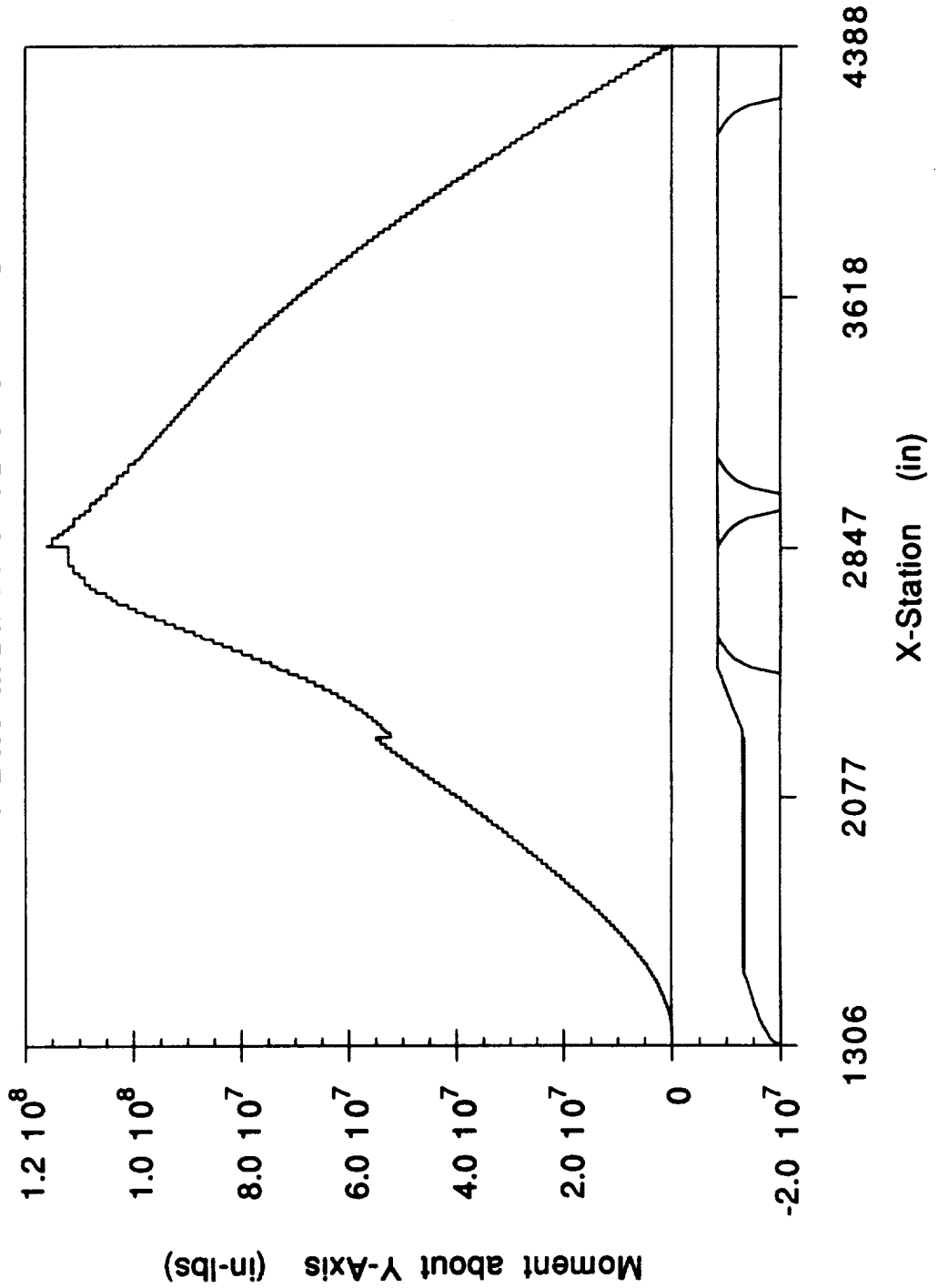

(

(

(

**NLS2 CORE - 12 km
Z-DIR MOMENT vs X-STATION**

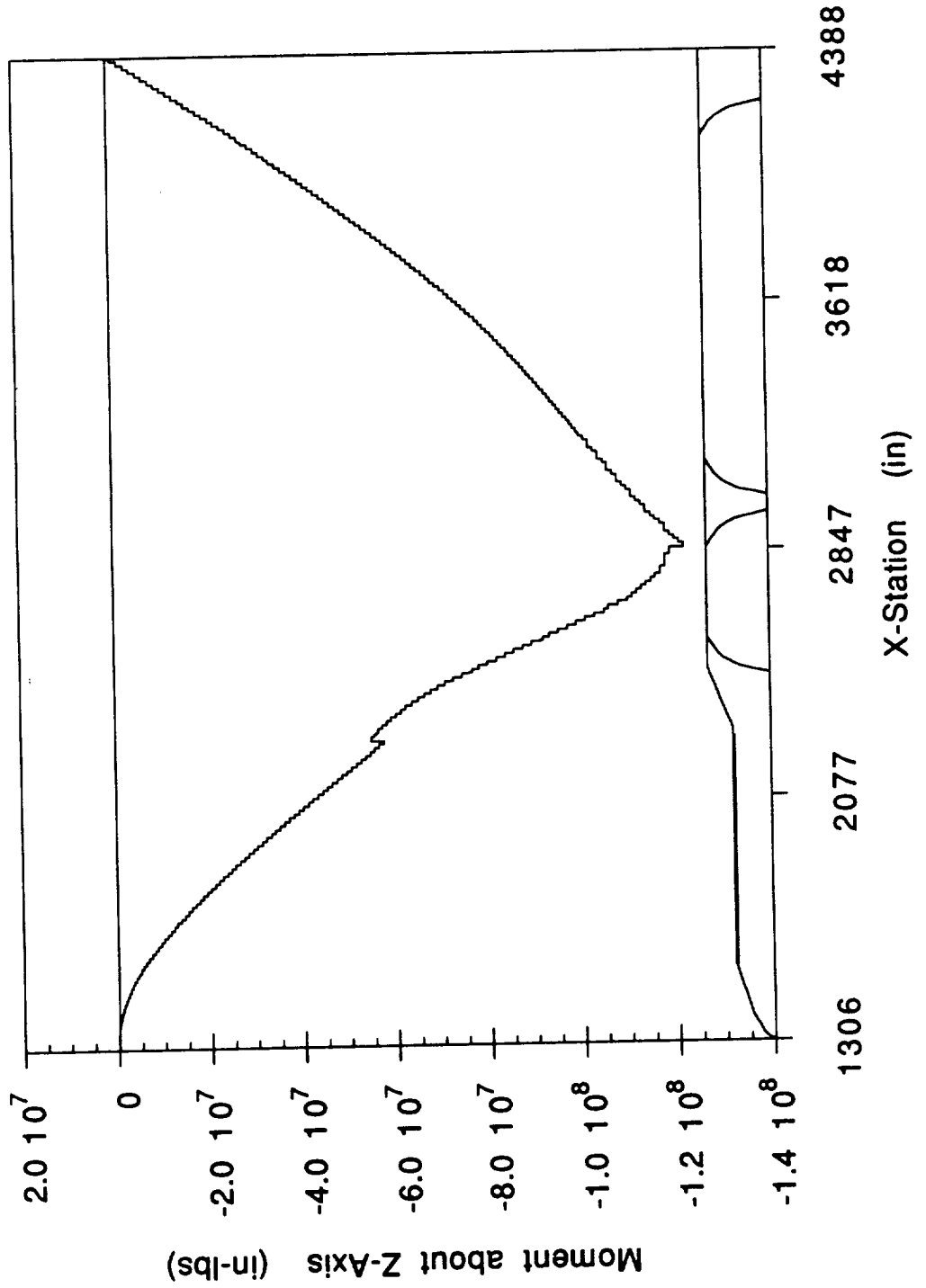

NLS2 CORE 12 km P EQUIVALENT vs X-STATION

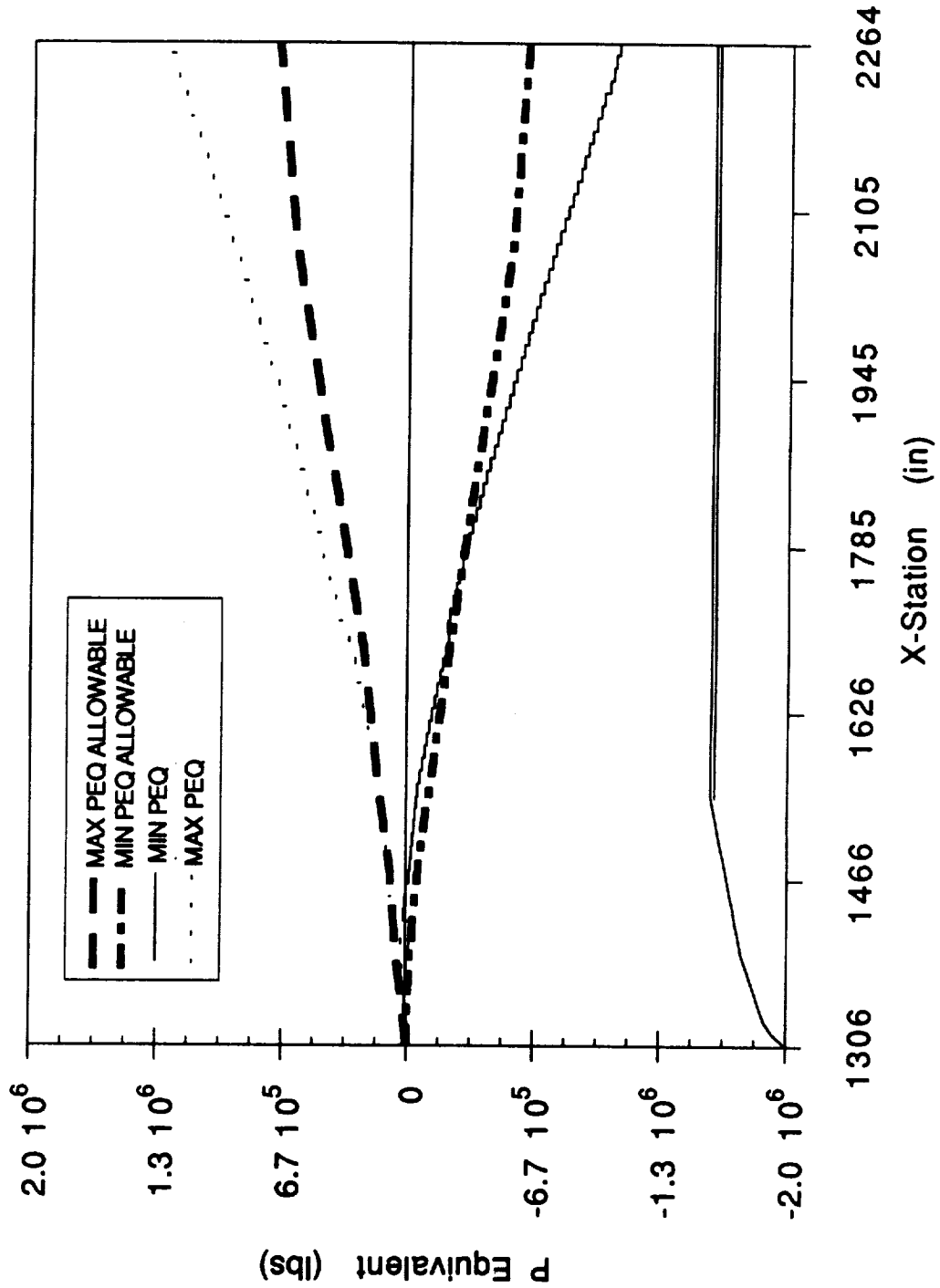

**NLS2 CORE 12 km
V EQUIVALENT vs X-STATION**

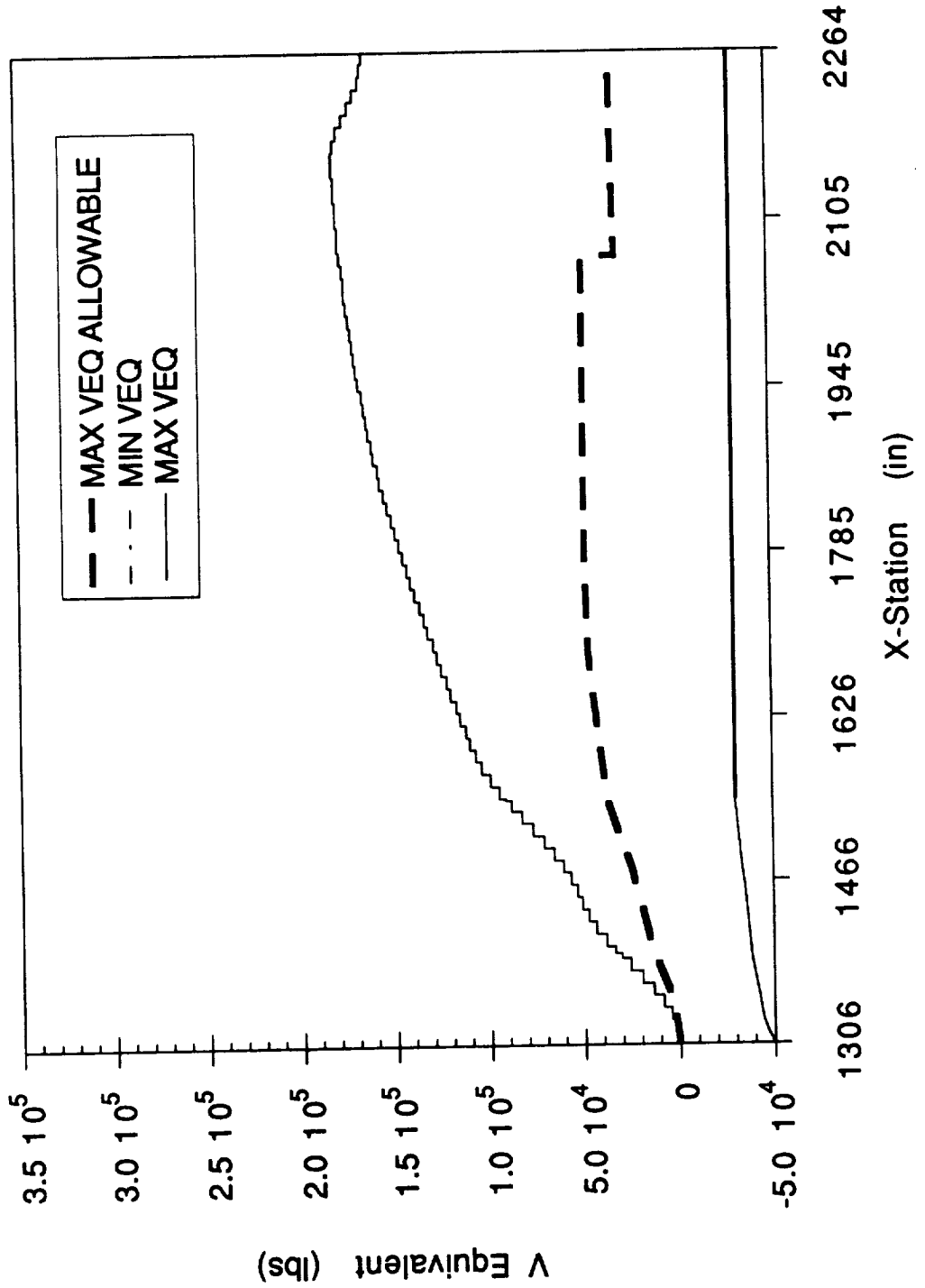

NLS2 CORE - 13km NX vs X-STATION

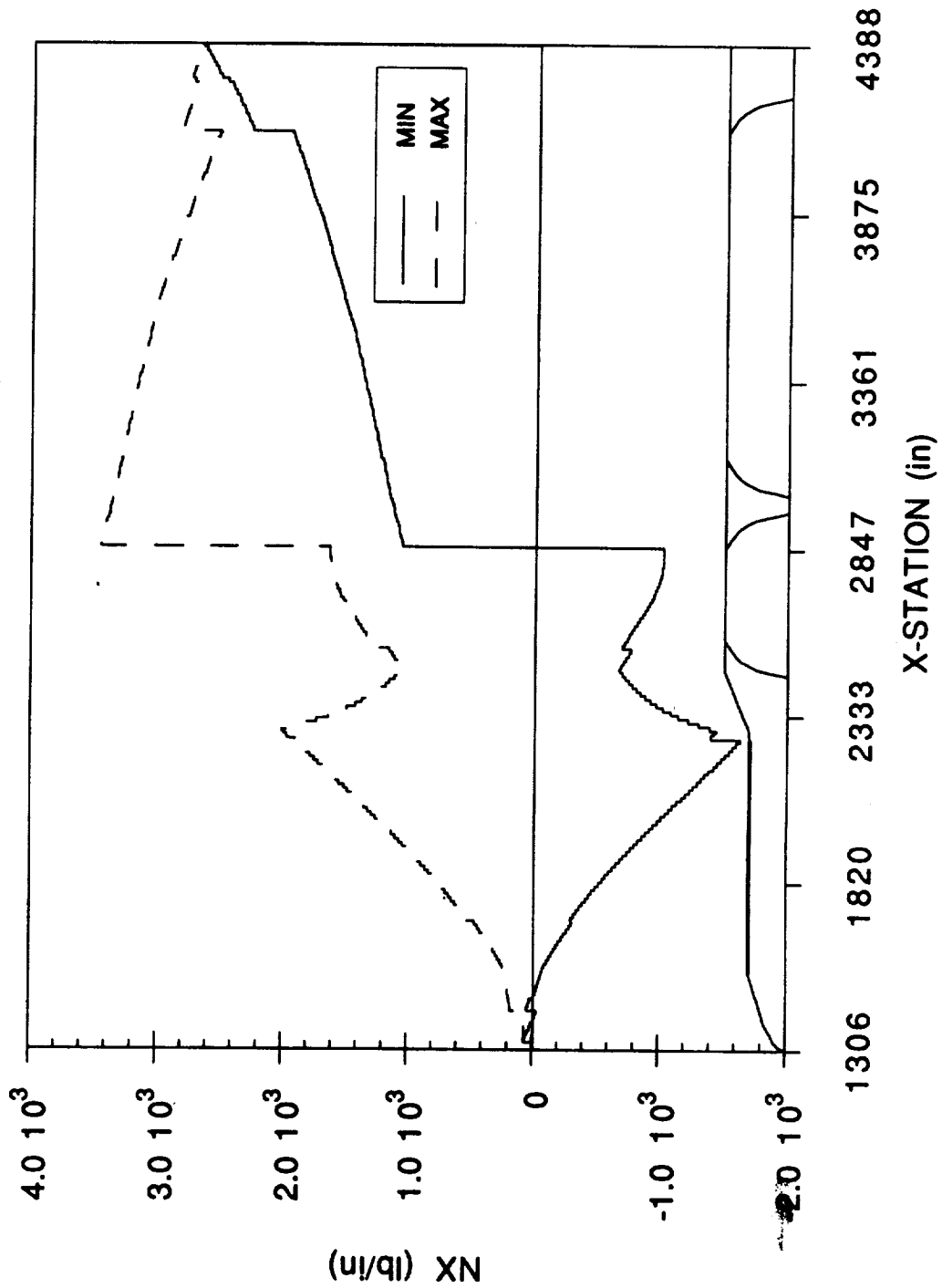

((

NLS2 CORE - 13 km
NV vs X-STATION

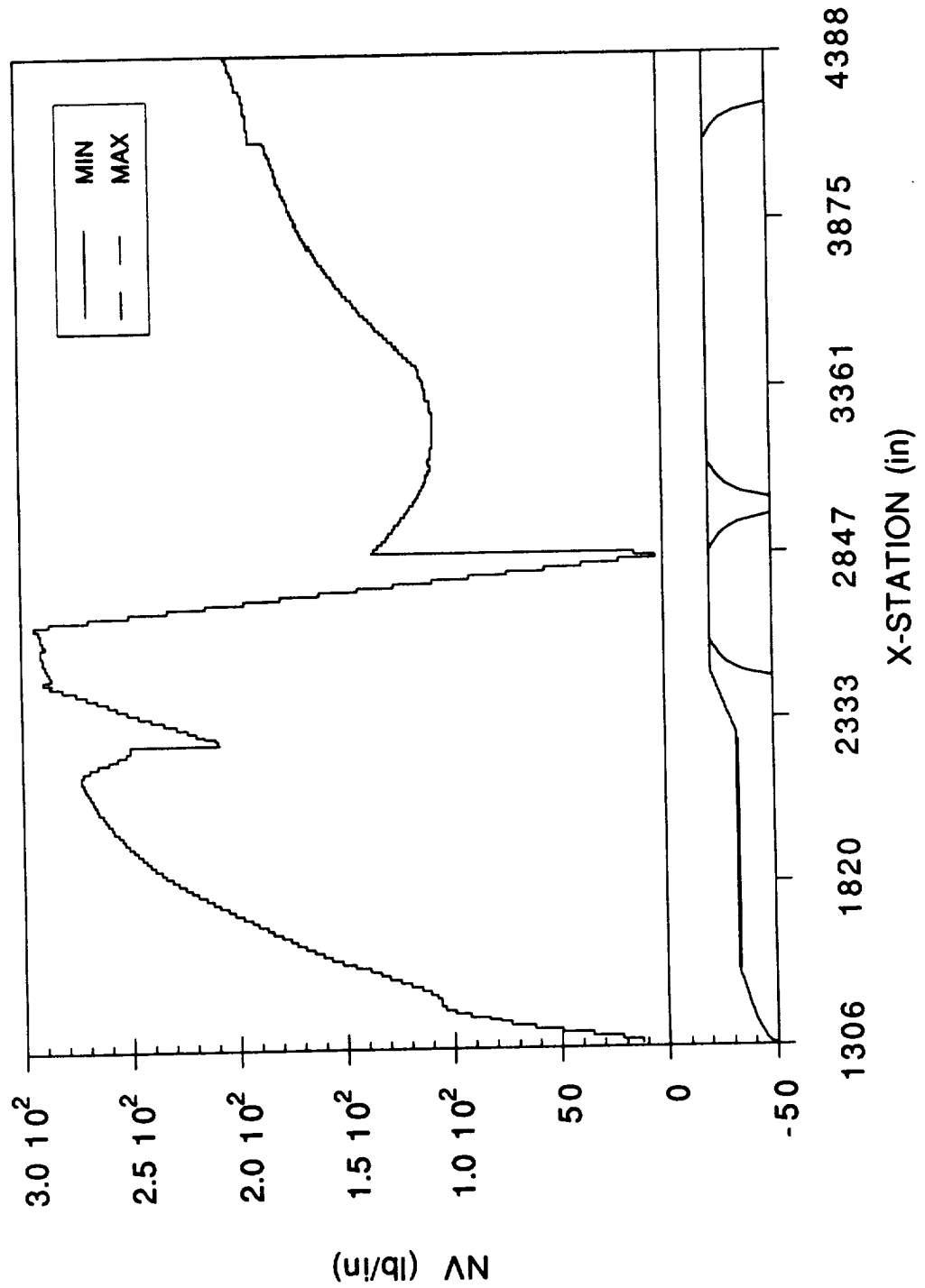

NLS2 CORE - 13 km AXIAL SHEAR vs X-STATION

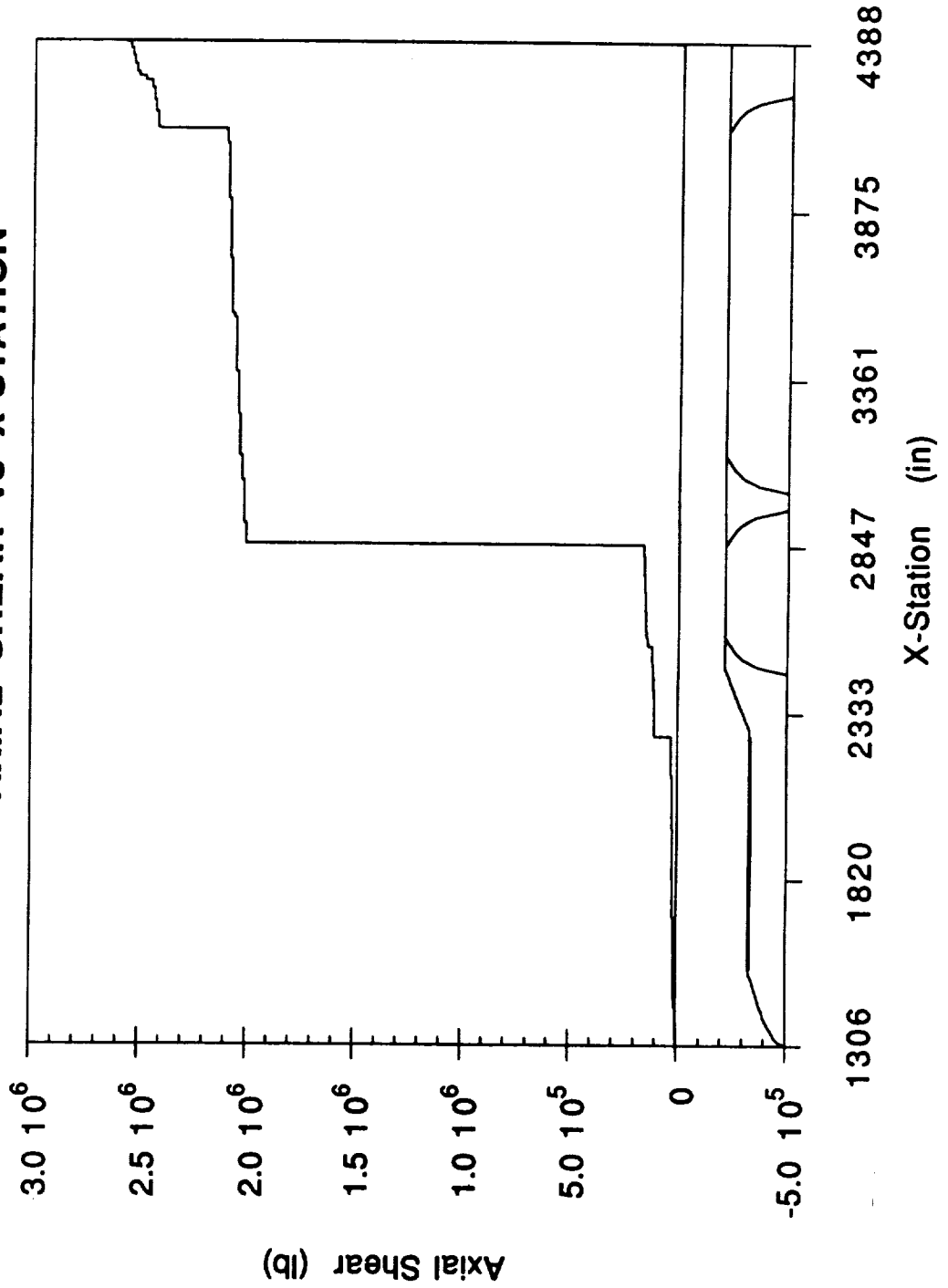

(((

**NLS2 CORE - 13 km
Y-DIR SHEAR VS X-STATION**

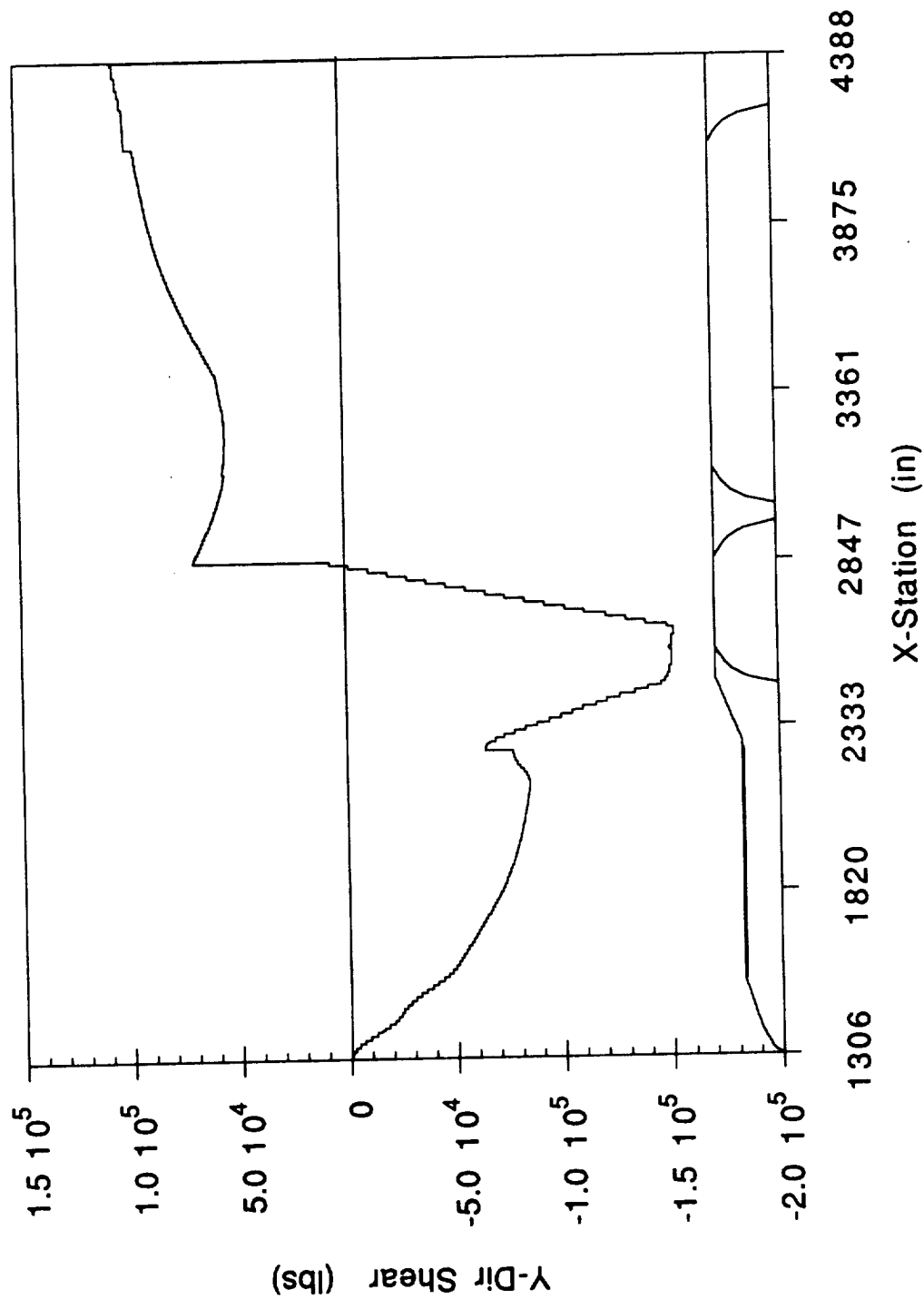

**NLS2 CORE - 13 km
Z-DIR SHEAR vs X-STATION**

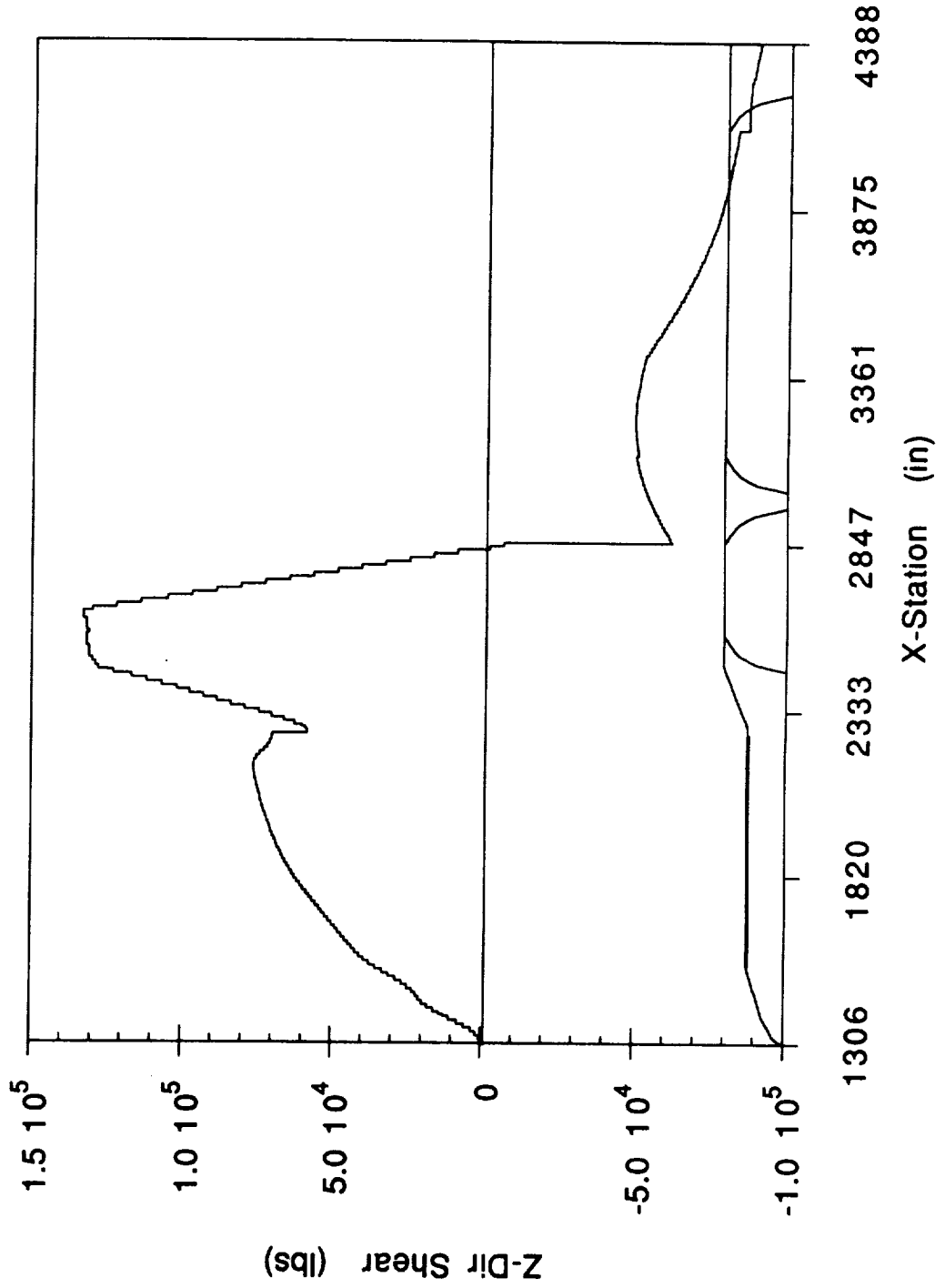

((

**NLS2 CORE - 13 km
Y-DIR MOMENT vs X-STATION**

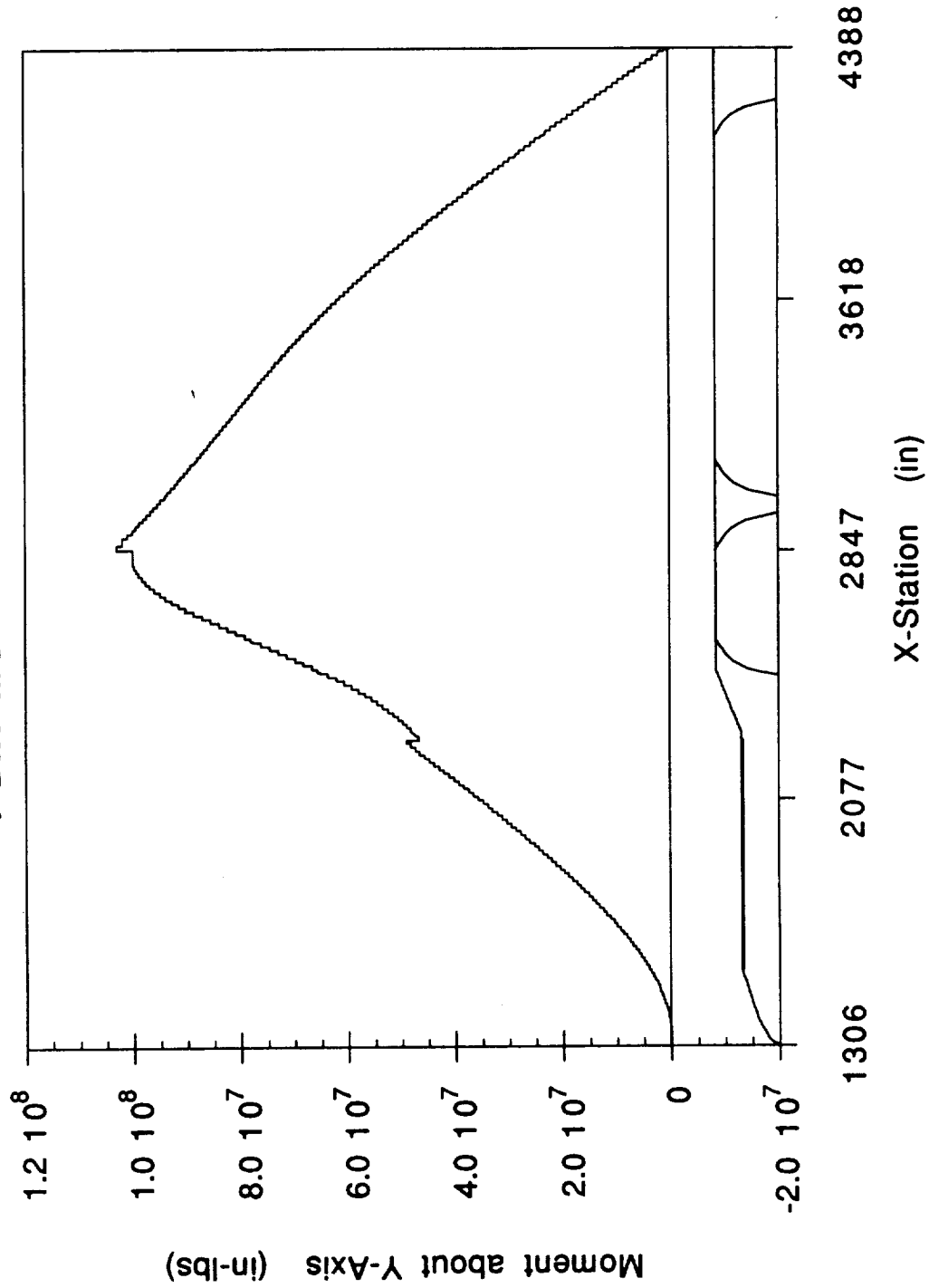

**NLS2 CORE - 13 km
Z-DIR MOMENT vs X-STATION**

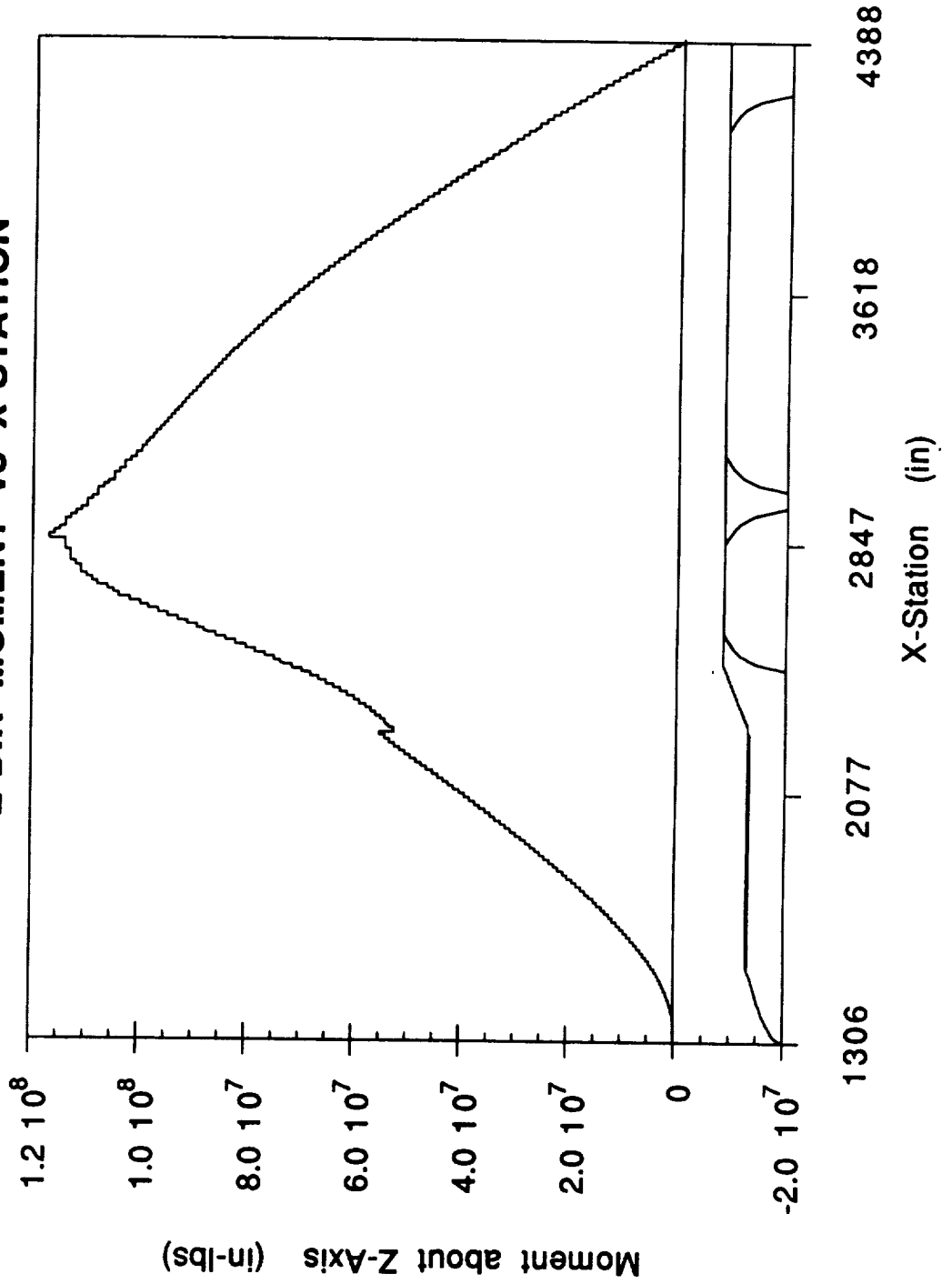

NLS2 CORE 13 km P EQUIVALENT vs X-STATION

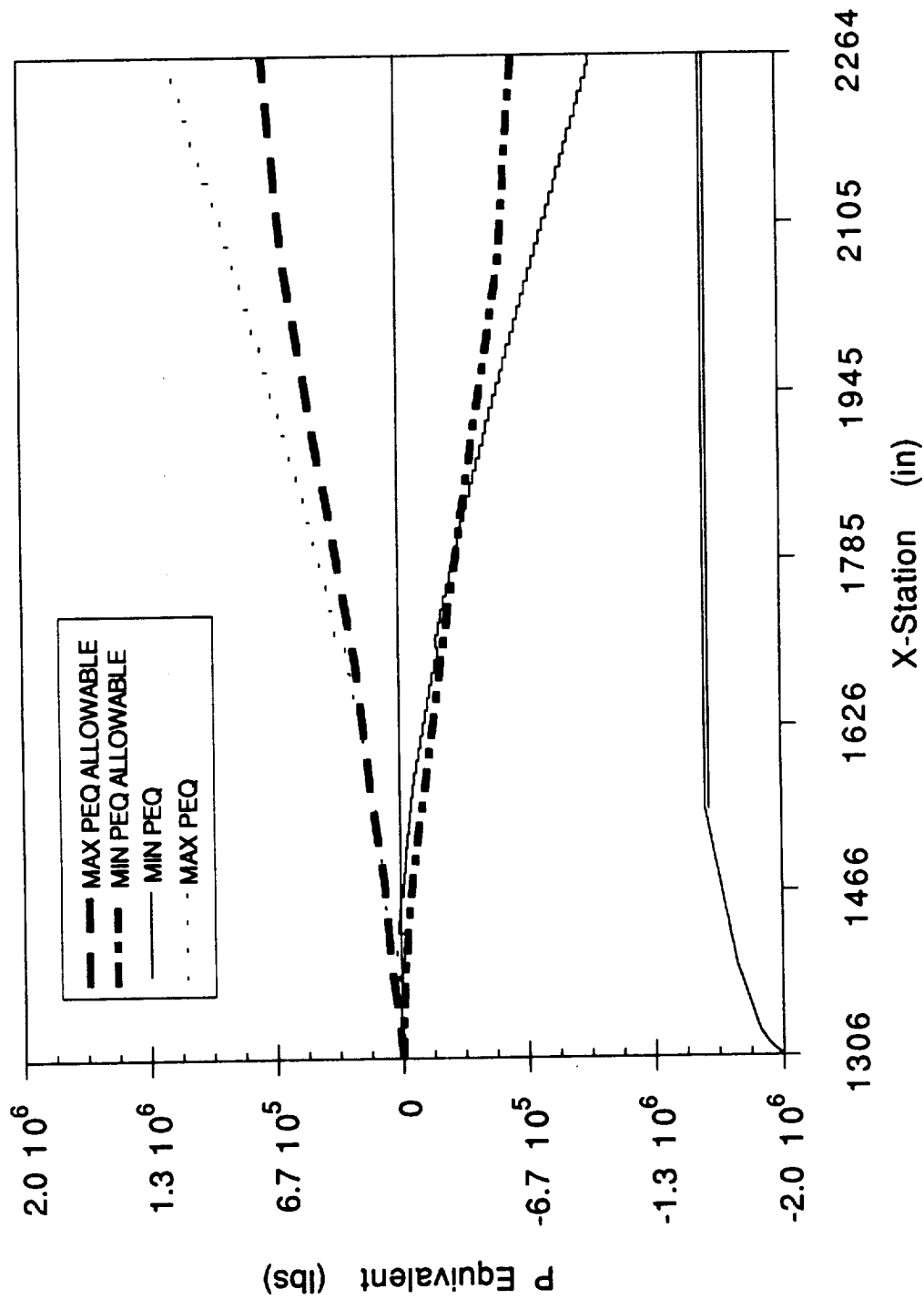

**NLS2 CORE 13 km
V EQUIVALENT vs X-STATION**

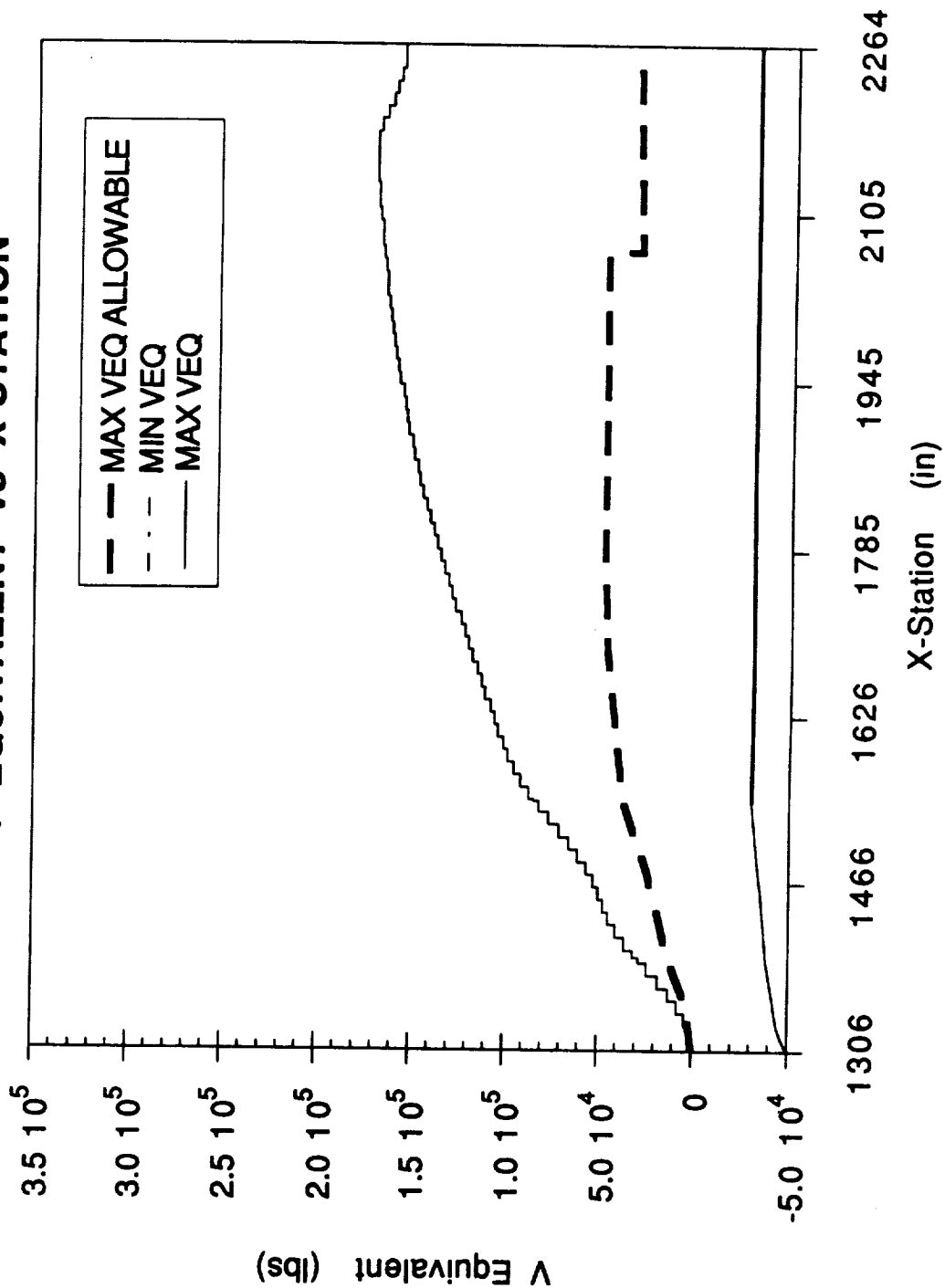

**NLS2 CORE - 14 km
NX vs X-STATION**

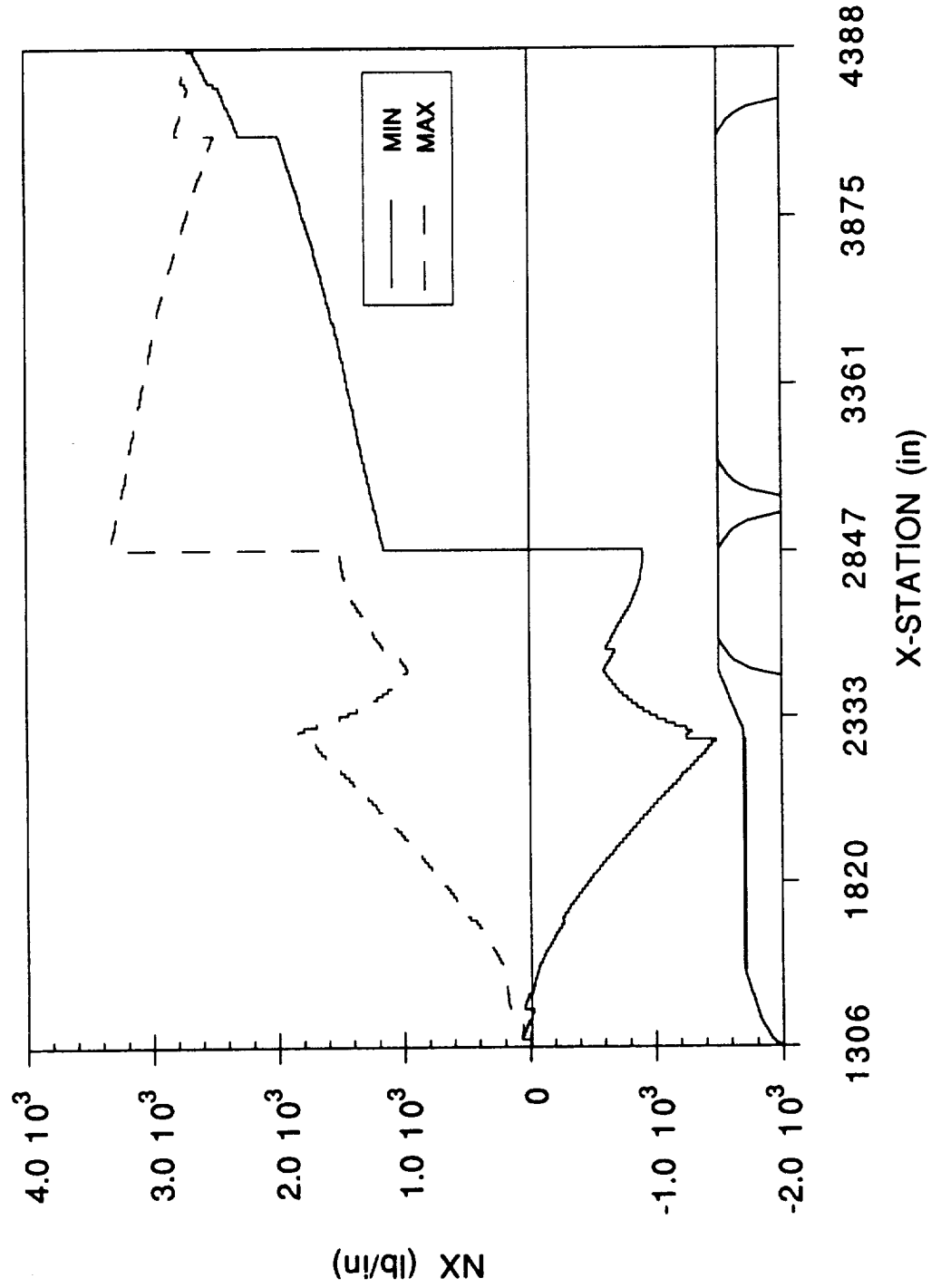

NLS2 CORE - 14 km NV vs X-STATION

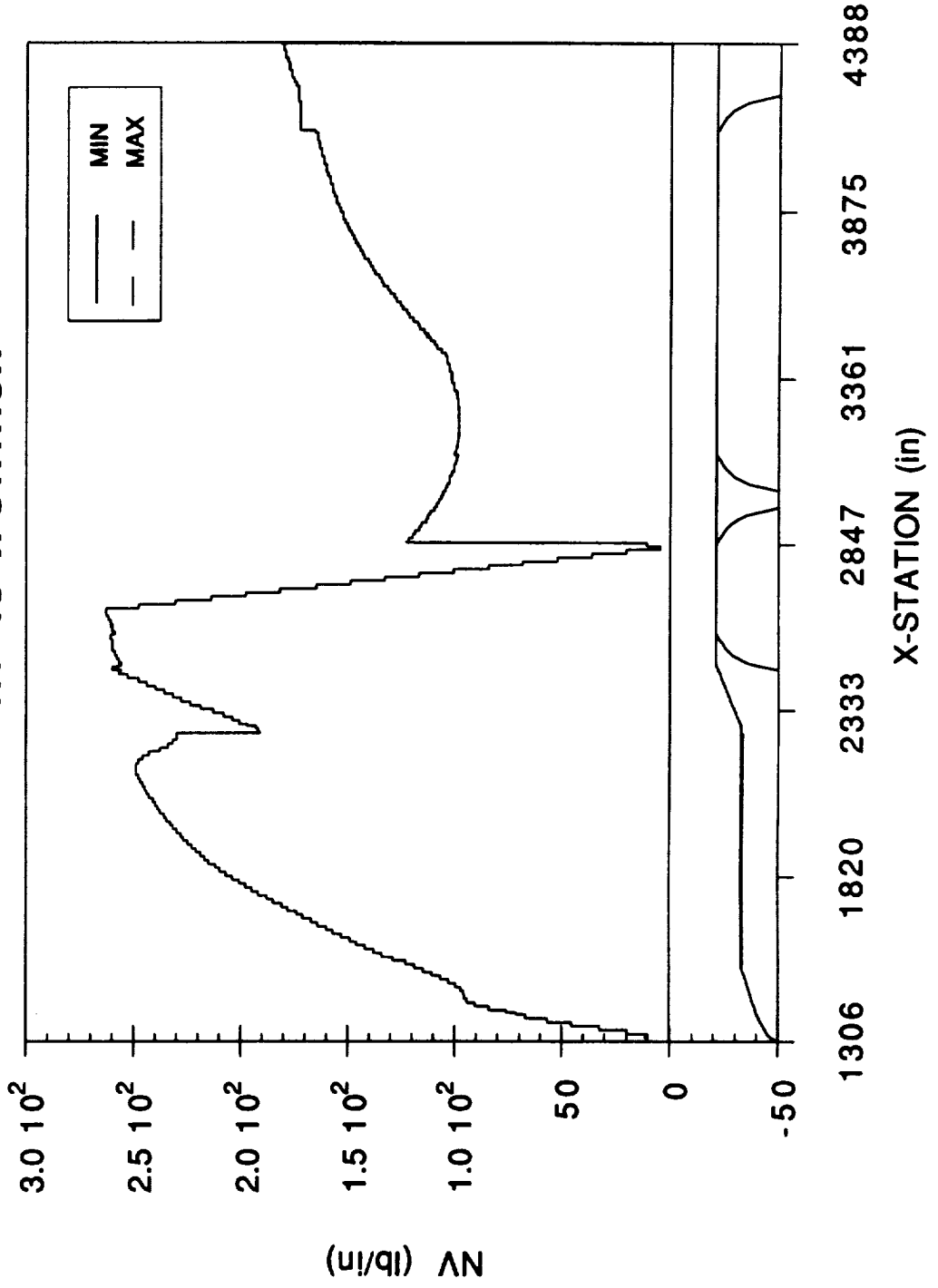

((

**NLS2 CORE - 14 km
AXIAL SHEAR vs X-STATION**

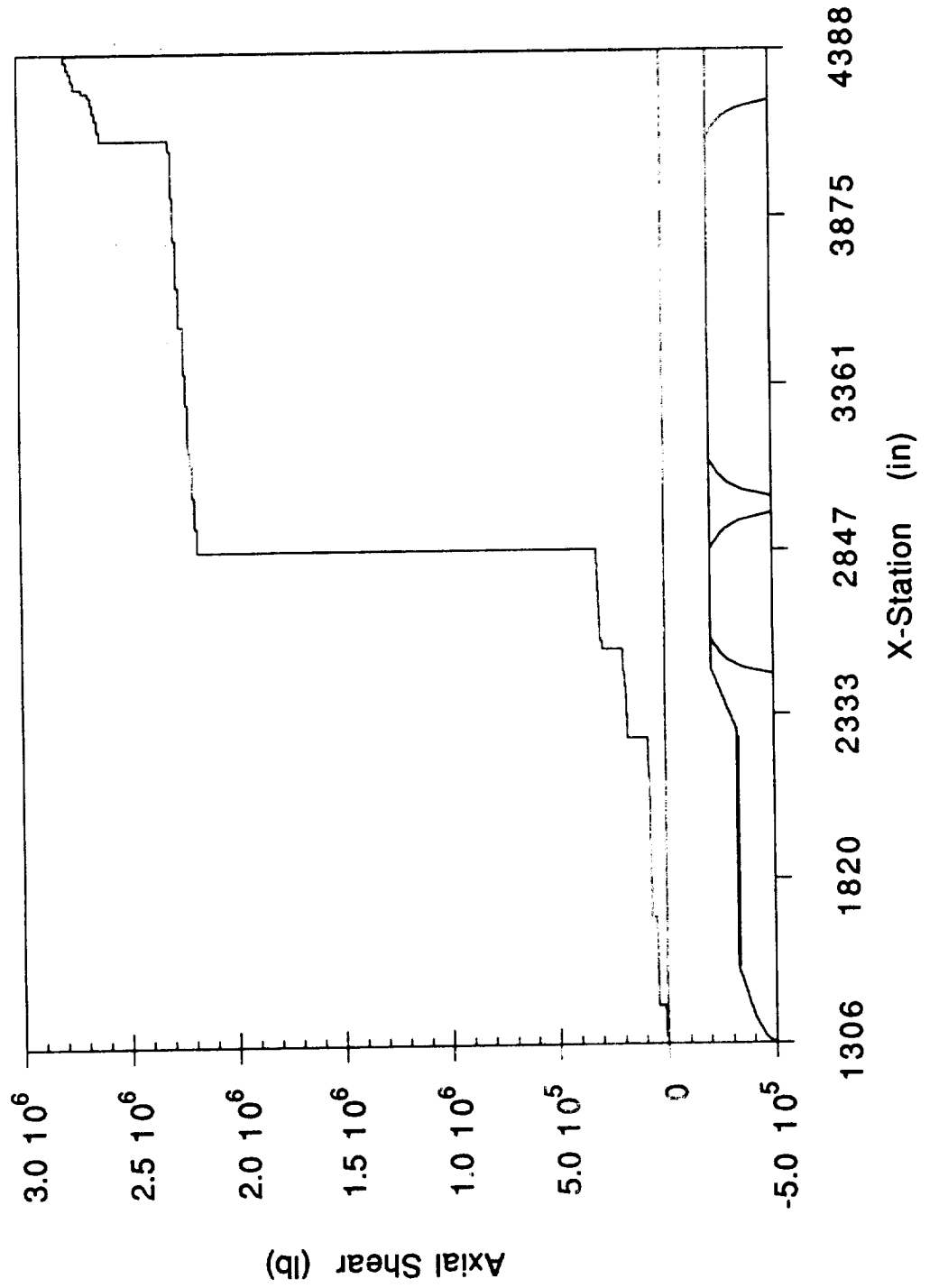

NLS2 CORE - 14 km
Y-DIR SHEAR vs X-STATION

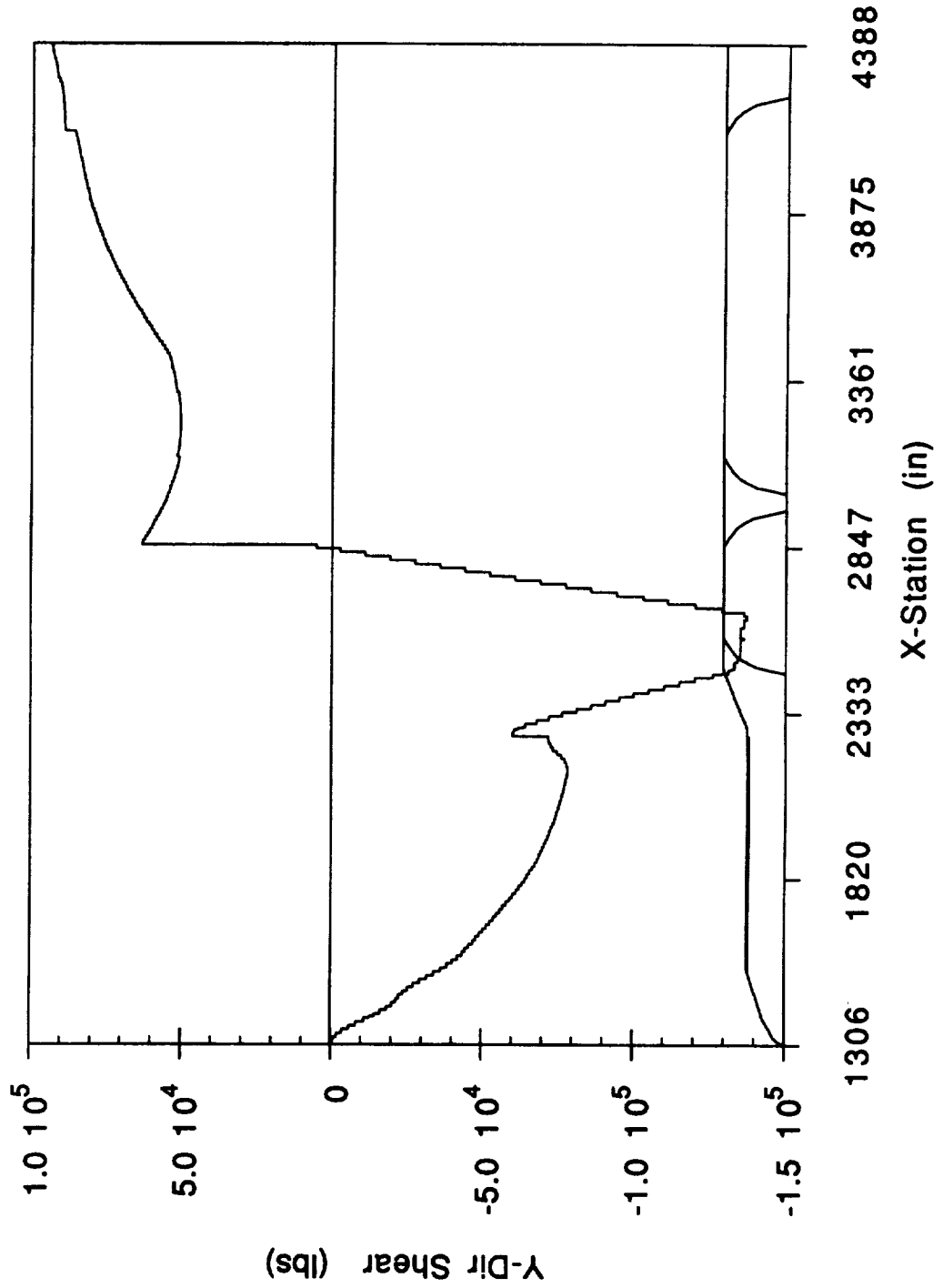

**NLS2 CORE - 14 km
Z-DIR SHEAR vs X-STATION**

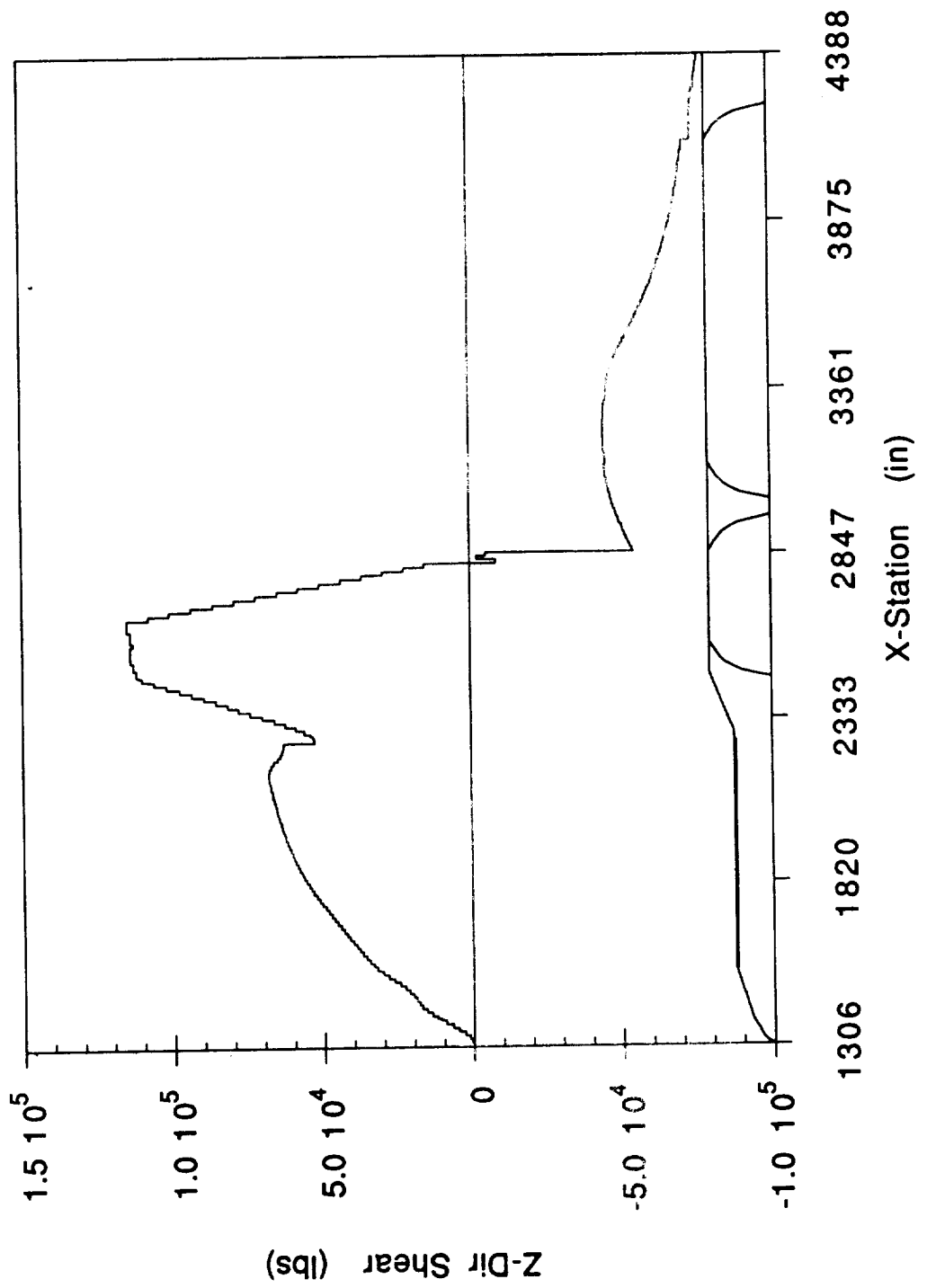

**NLS2 CORE - 14 km
Y-DIR MOMENT vs X-STATION**

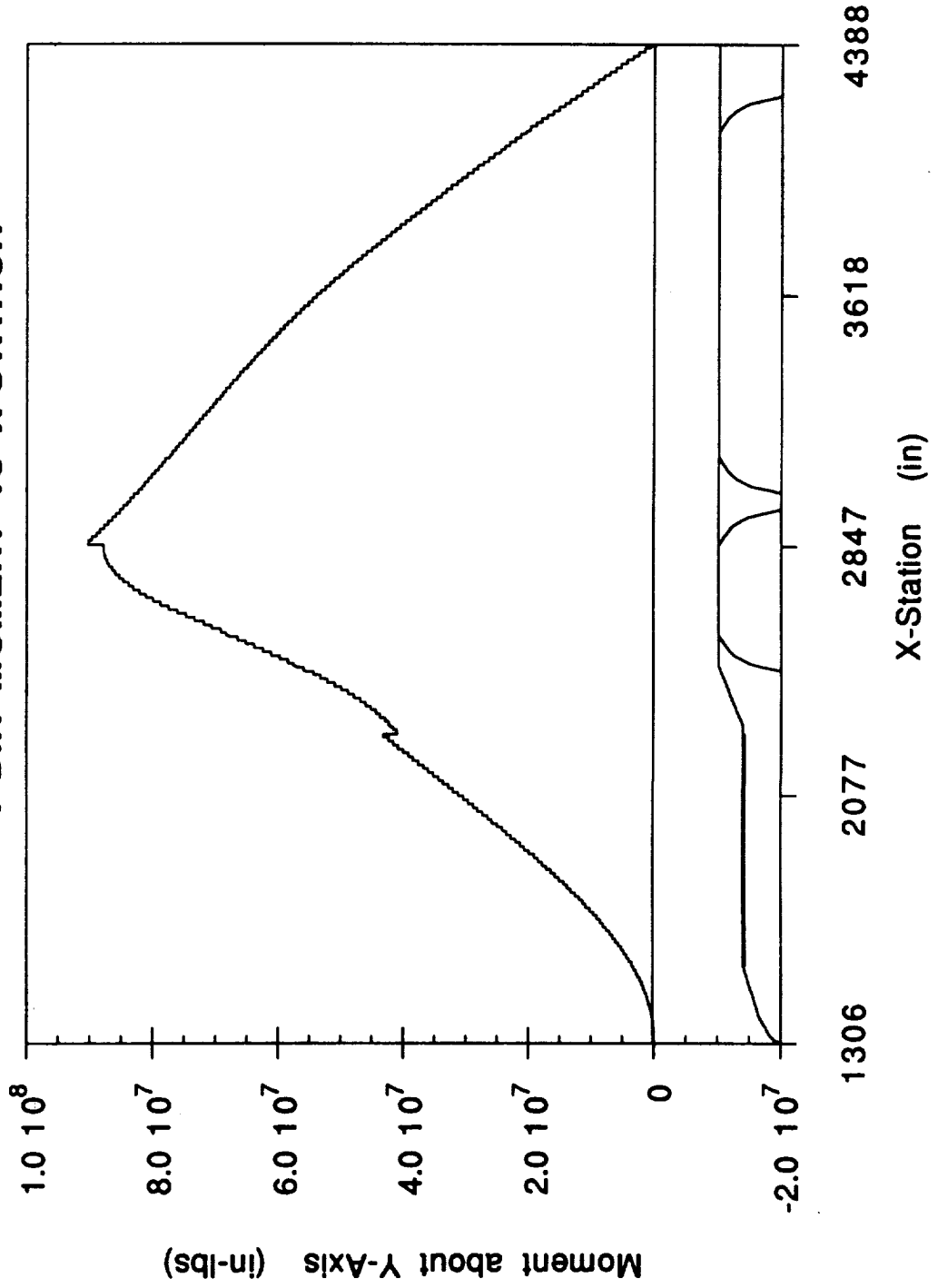

**NLS2 CORE - 14 km
Z-DIR MOMENT vs X-STATION**

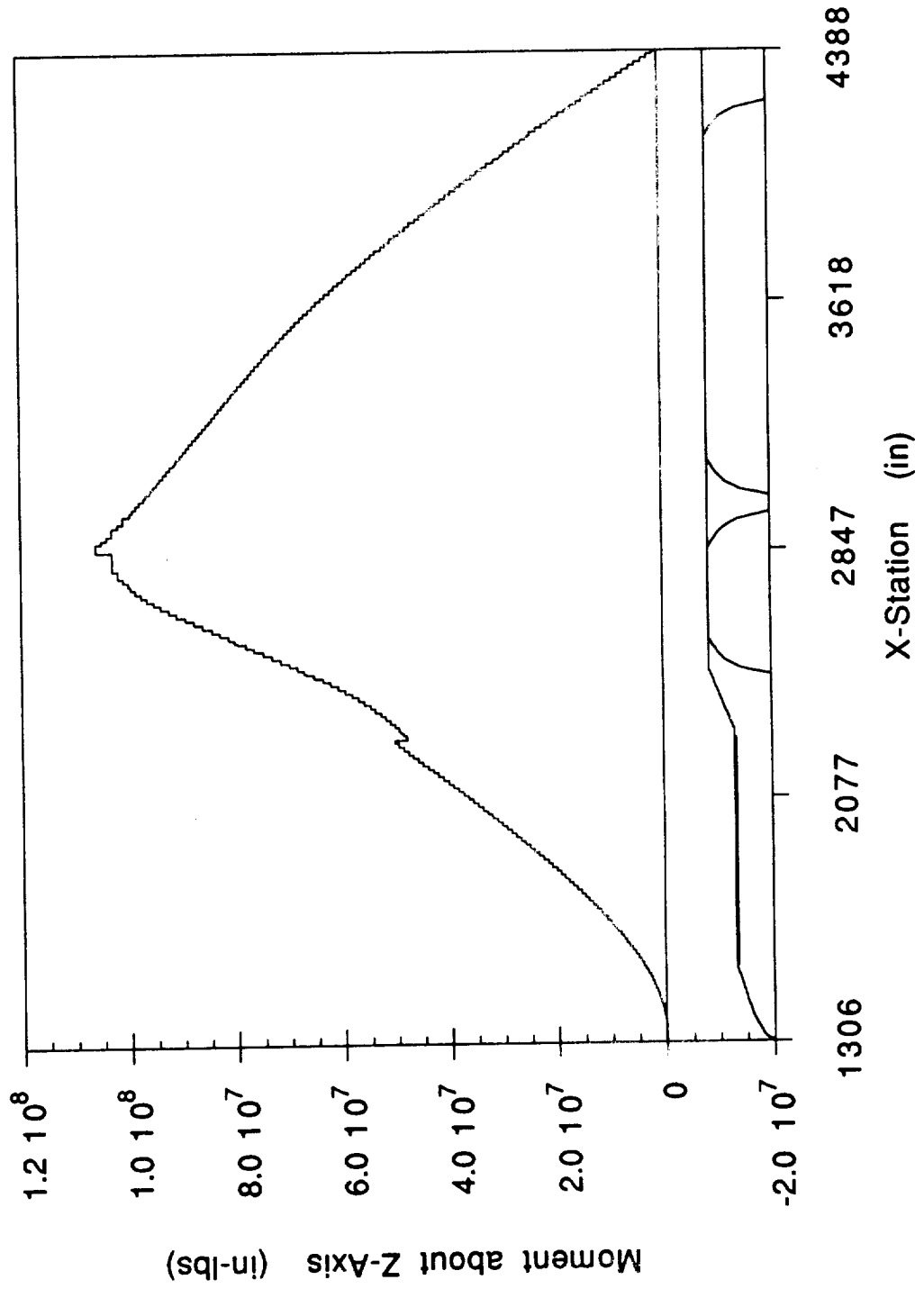

C-6

**NLS2 CORE 14 km
P EQUIVALENT vs X-STATION**

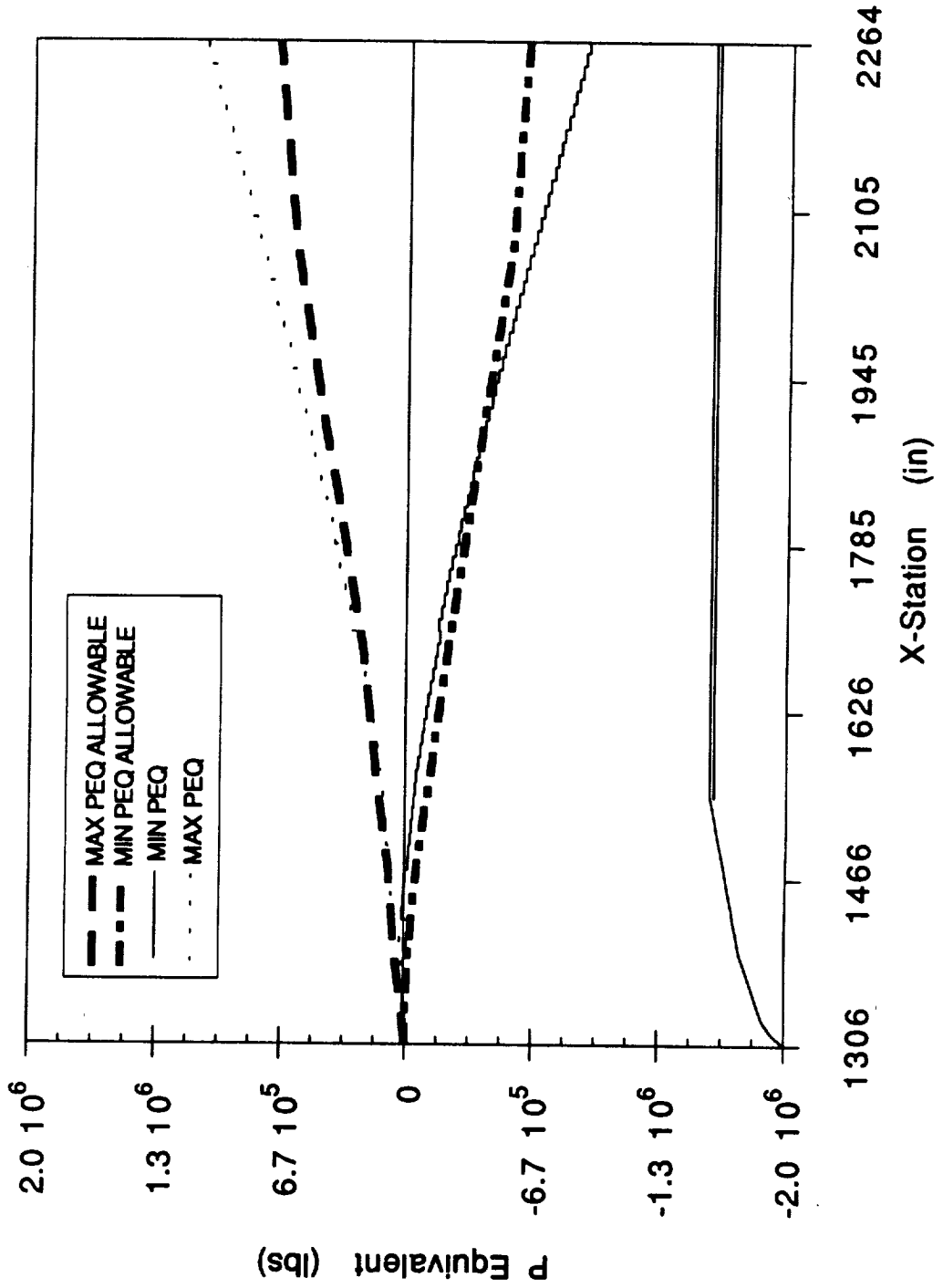

**NLS2 CORE 14 km
V EQUIVALENT vs X-STATION**

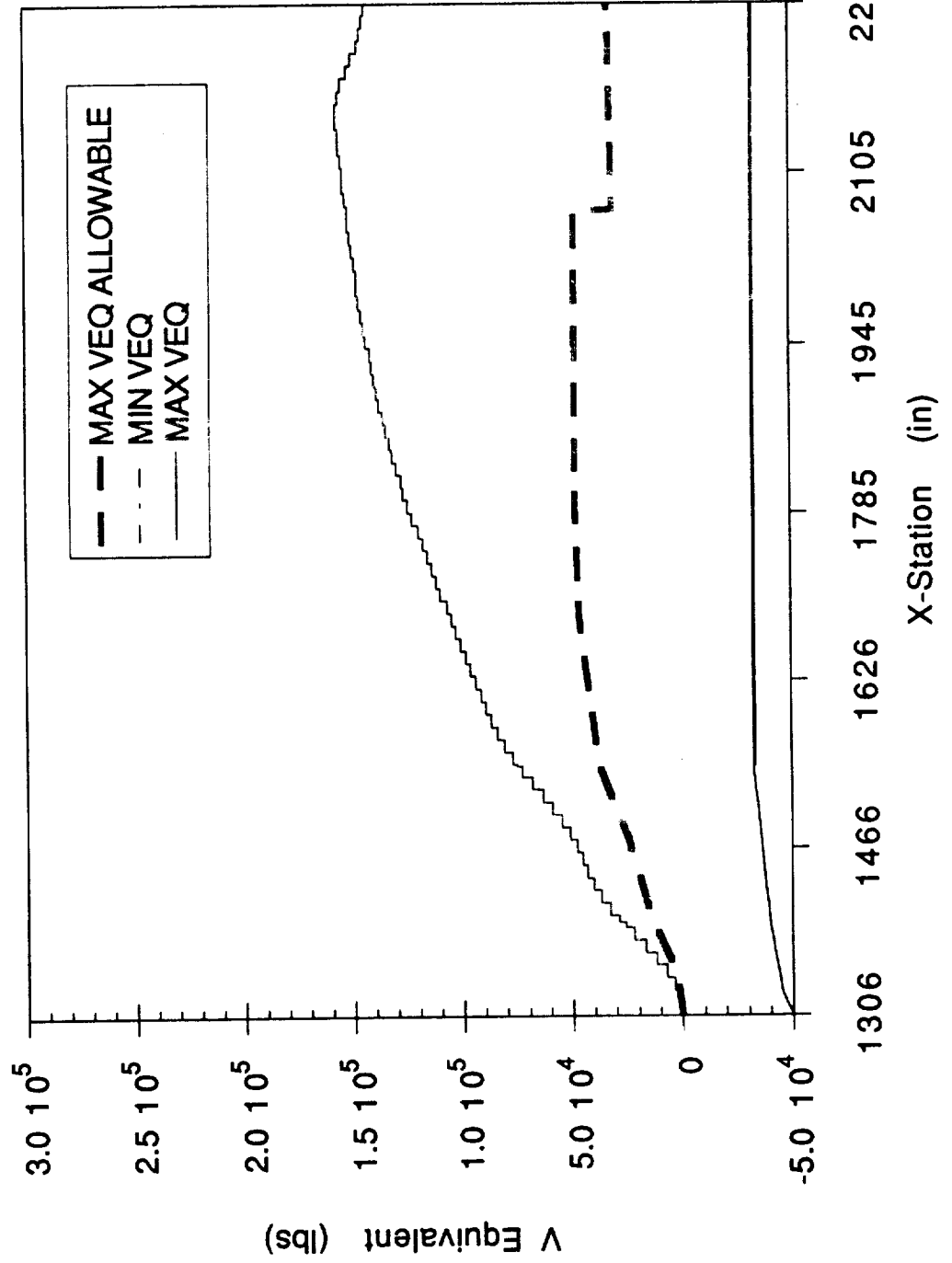

**NLS2 CORE - MAX G FIRST STAGE
NX vs X-STATION**

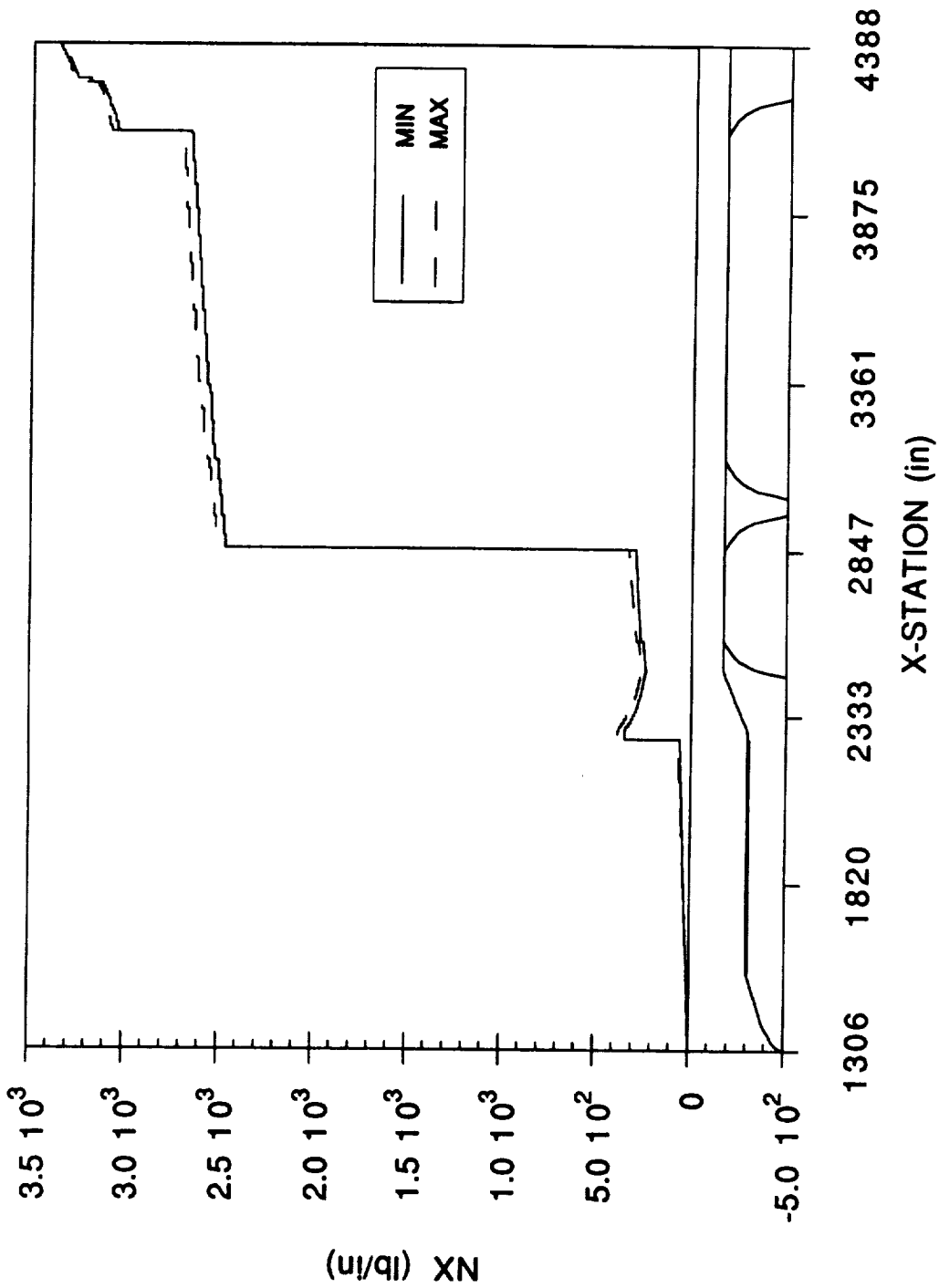

**NLS2 CORE - MAX G FIRST STAGE
NV vs X-STATION**

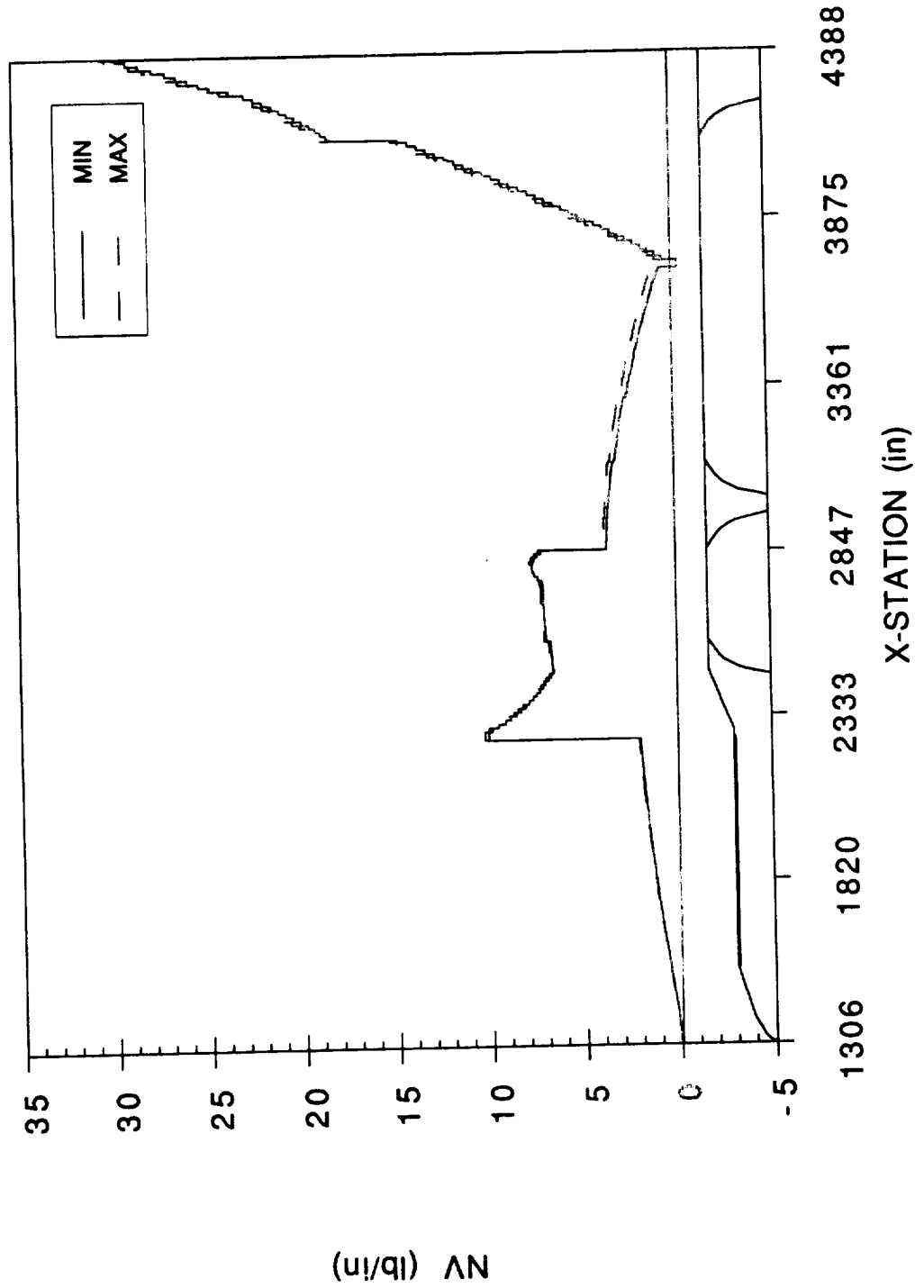

**NLS2 CORE - MAX G FIRST STAGE
AXIAL SHEAR vs X-STATION**

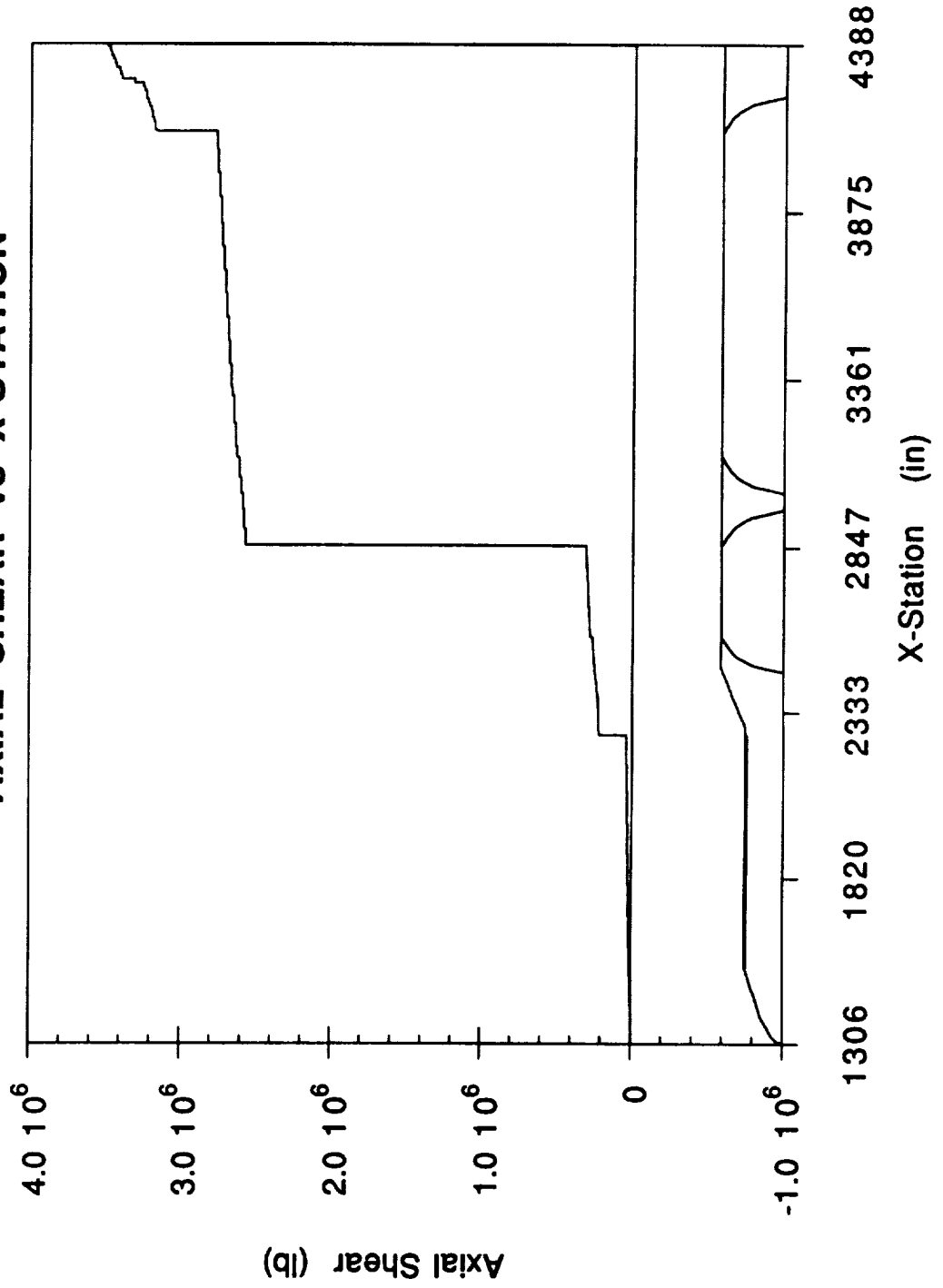

**NLS2 CORE - MAX G FIRST STAGE
Y-DIR SHEAR vs X-STATION**

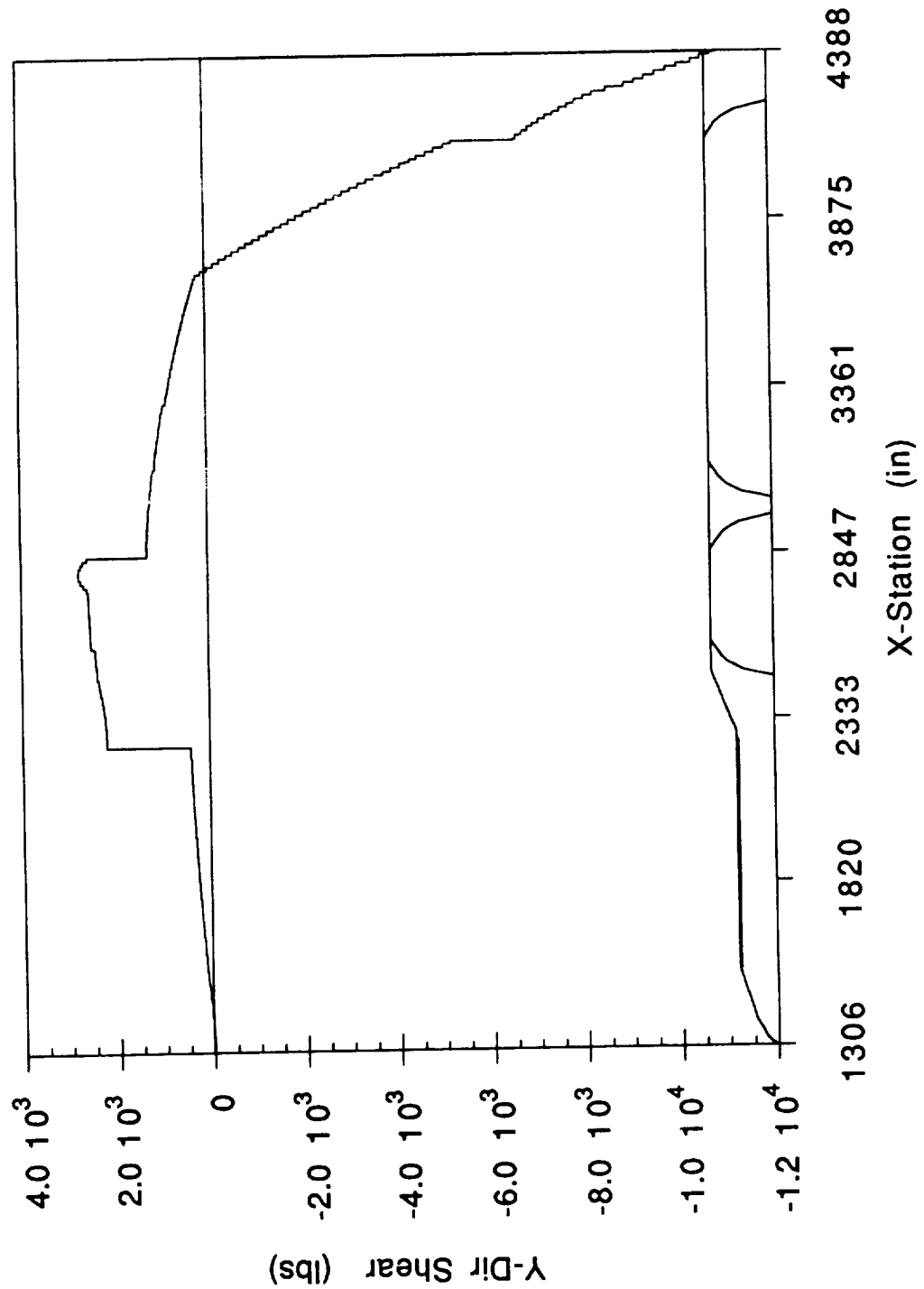

**NLS2 CORE - MAX G FIRST STAGE
Z-DIR SHEAR vs X-STATION**

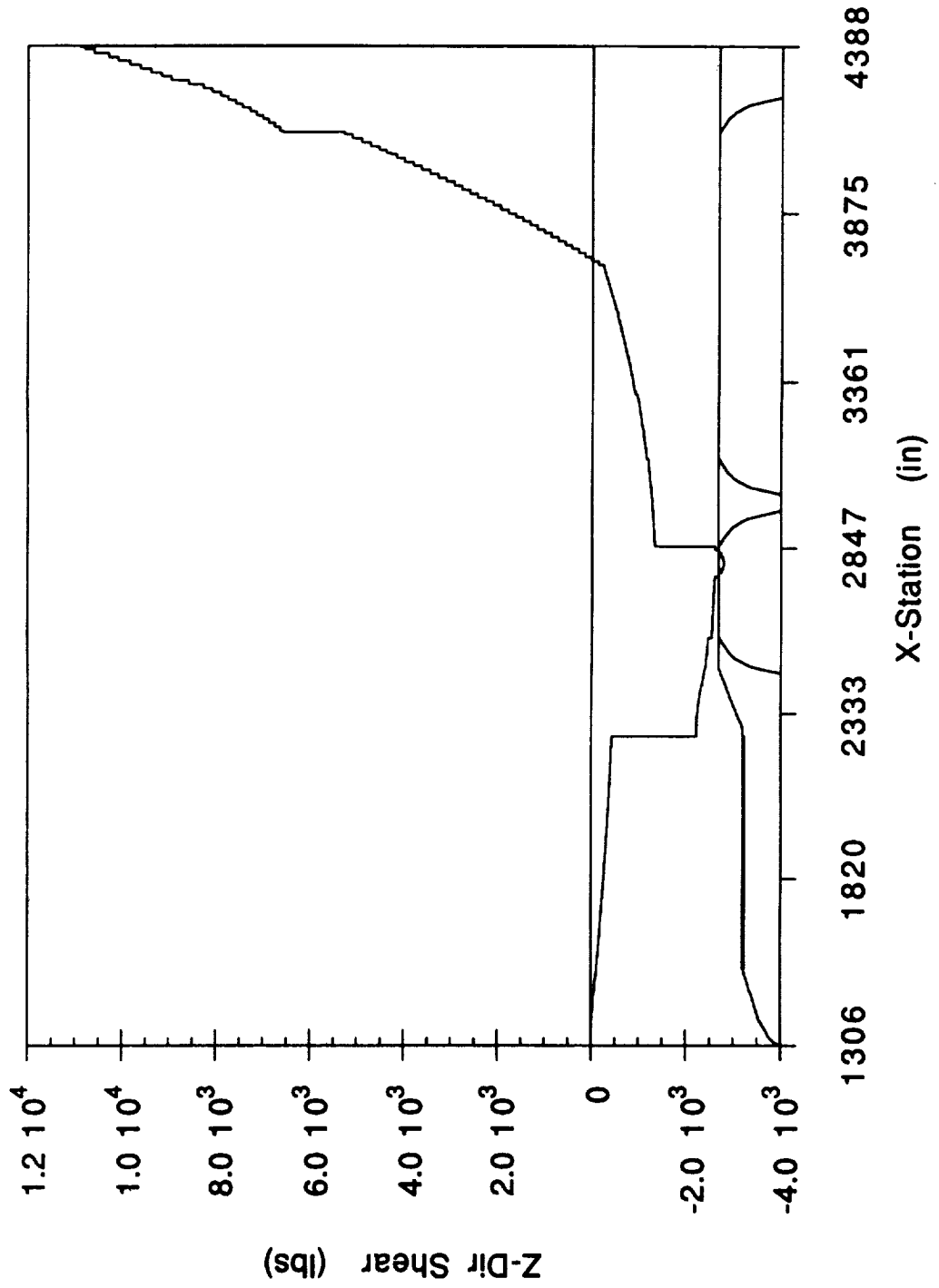

**NLS2 CORE - MAX G FIRST STAGE
Y-DIR MOMENT vs X-STATION**

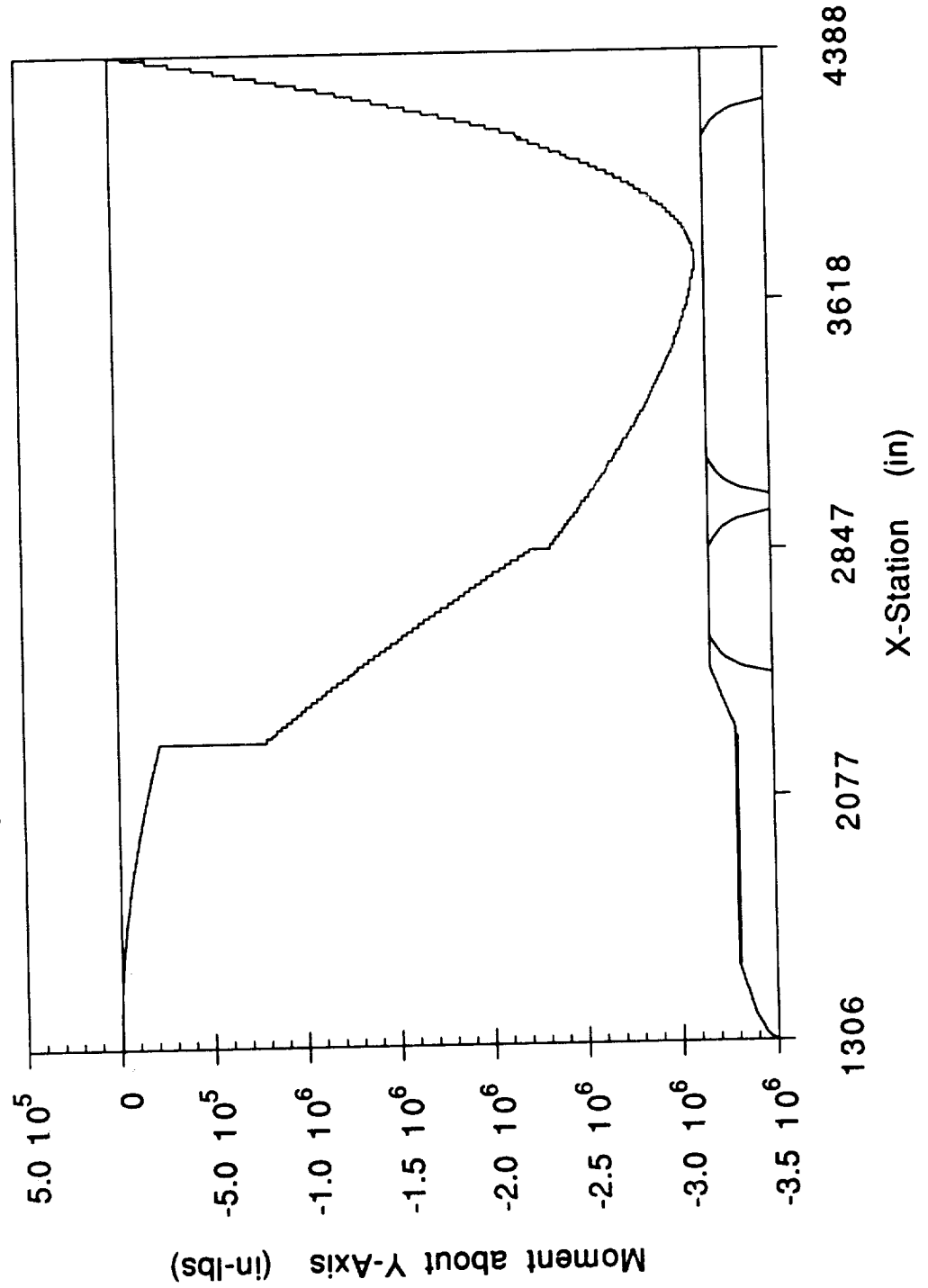

NLS2 CORE - MAX G FIRST STAGE Z-DIR MOMENT vs X-STATION

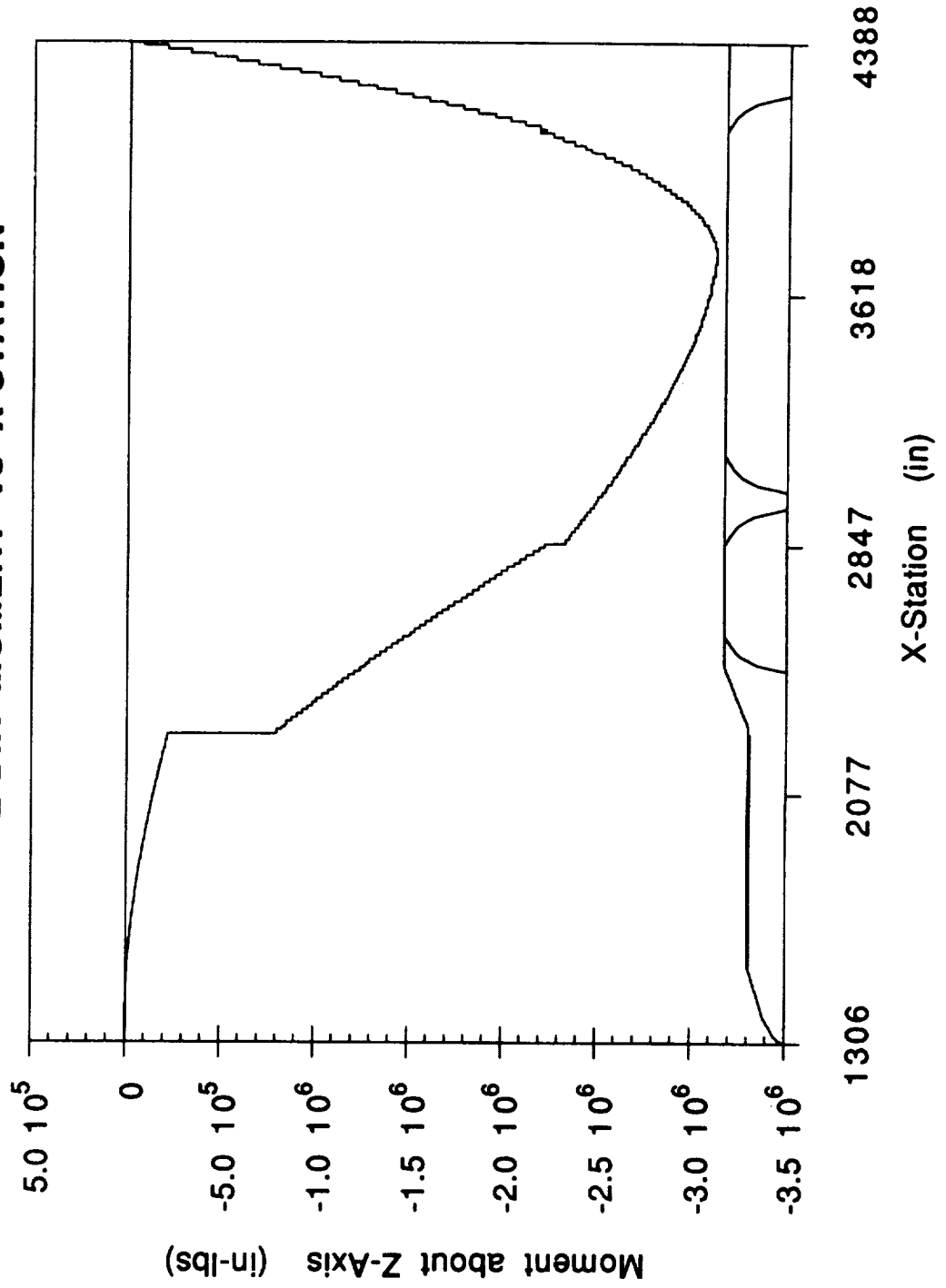

(((

NLS2 CORE MAX G FIRST STAGE P EQUIVALENT vs X-STATION

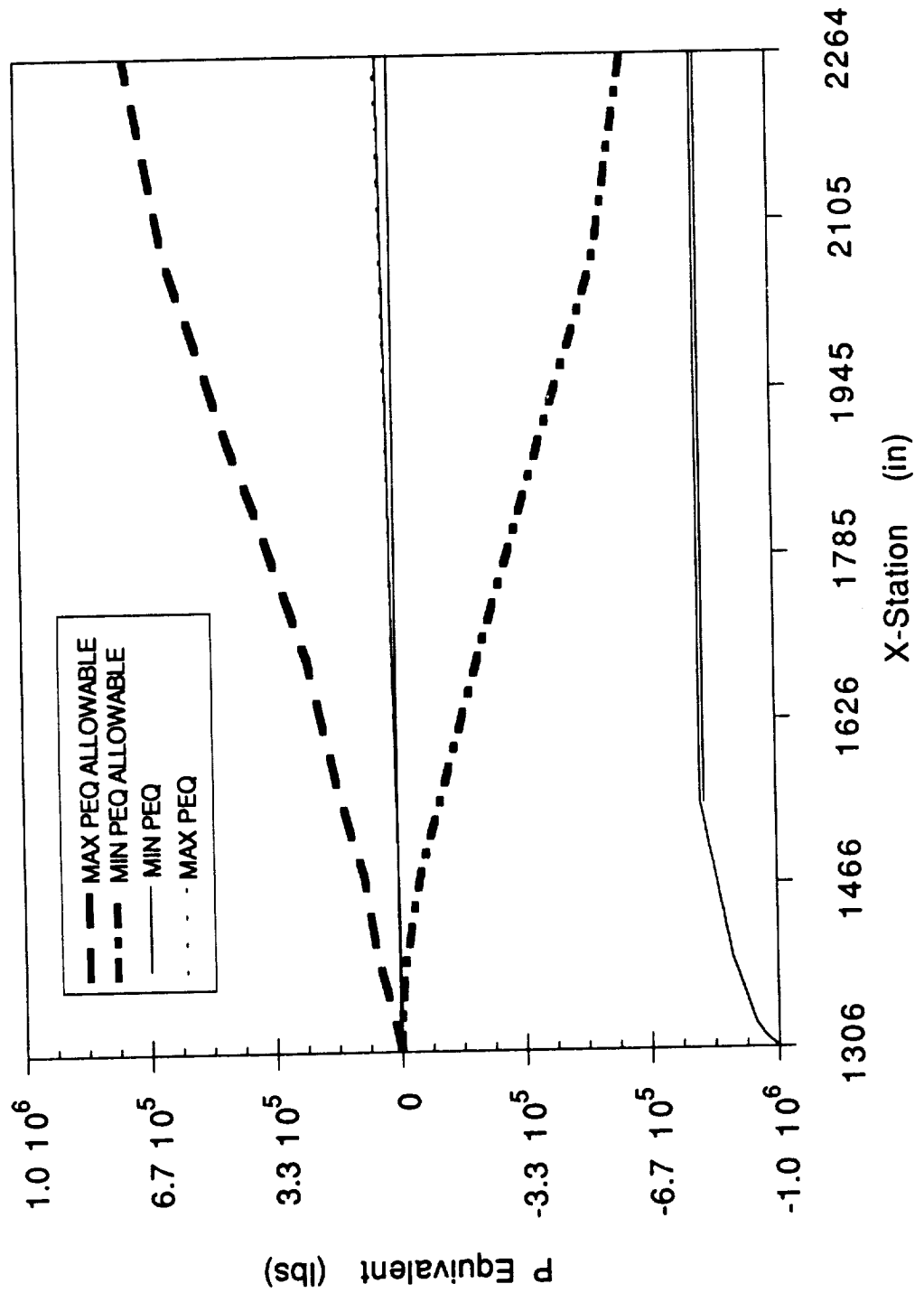

**NLS2 CORE MAX G FIRST STAGE
V EQUIVALENT vs X-STATION**

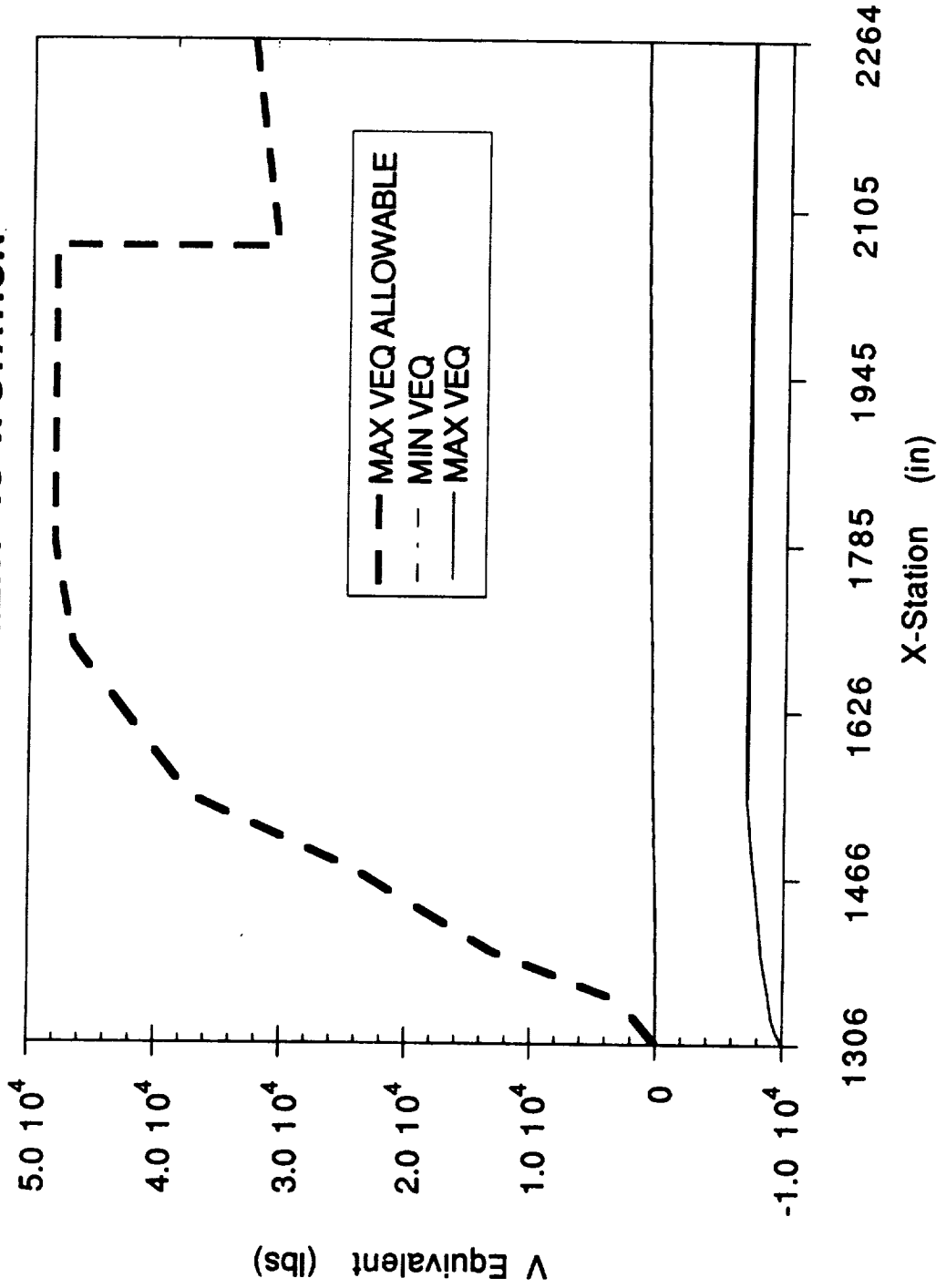

**NLS2 CORE - MAX G SECOND STAGE
NX vs X-STATION**

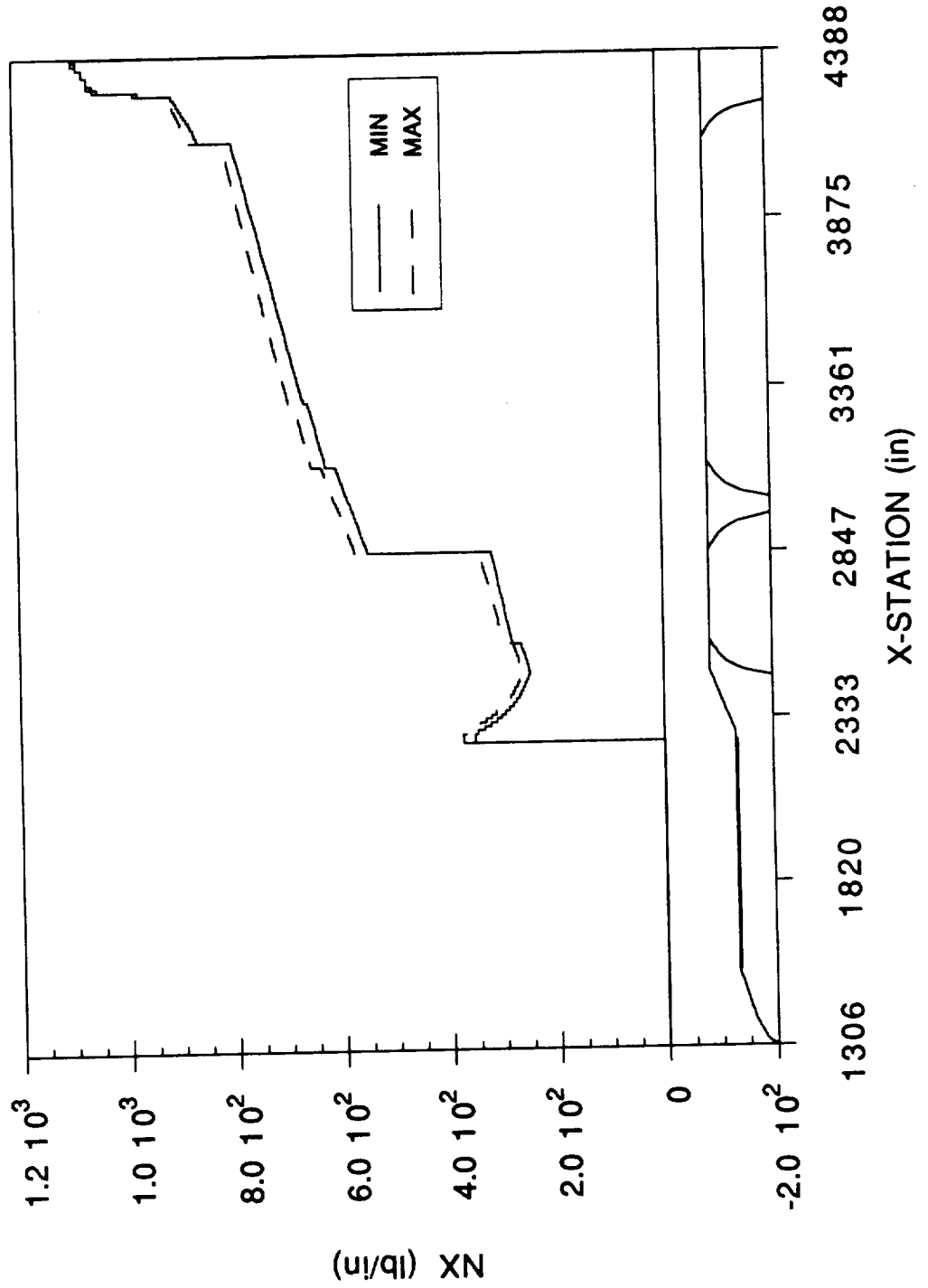

**NLS2 CORE - MAX G SECOND STAGE
NV vs X-STATION**

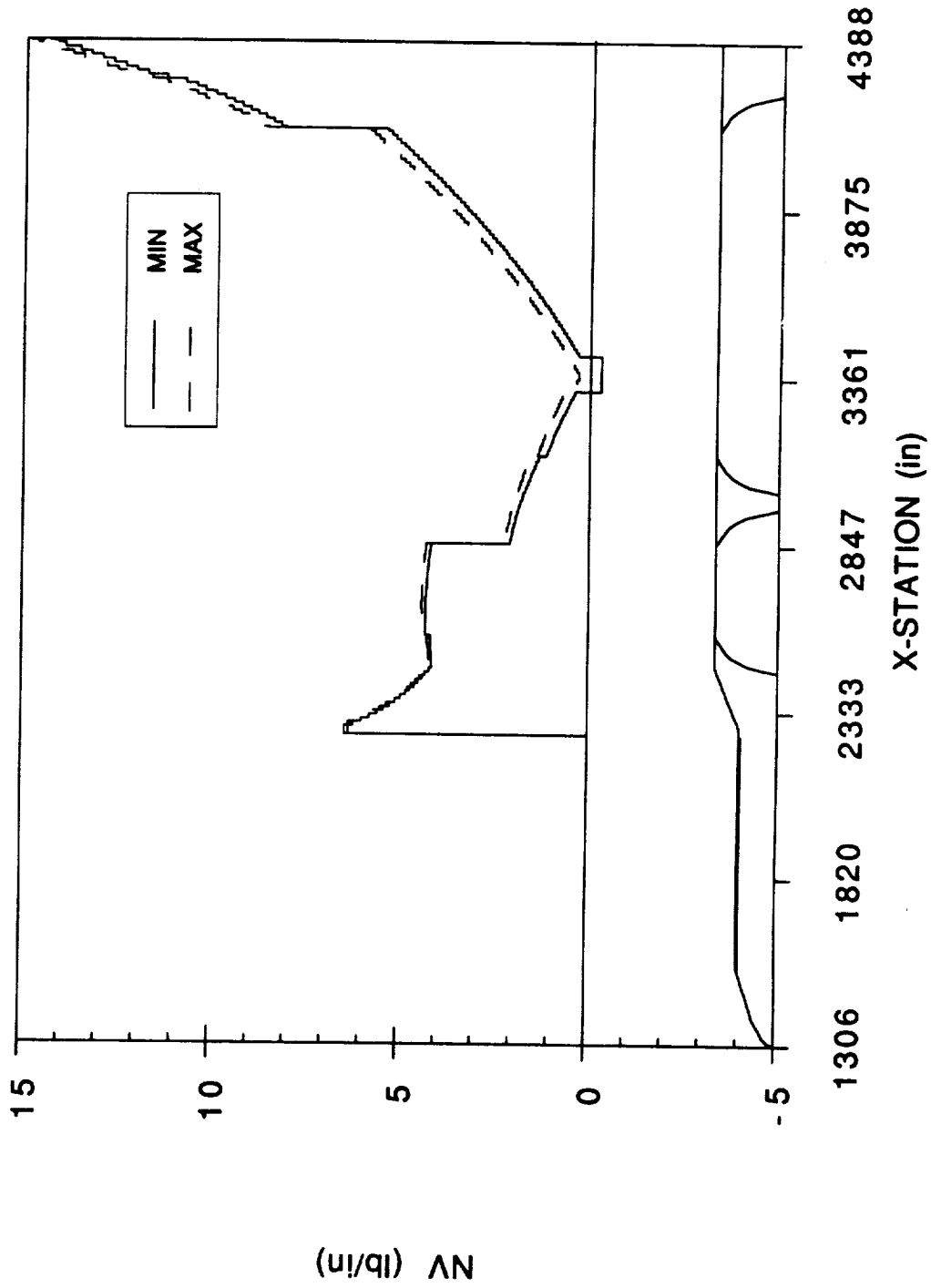

**NLS2 CORE - MAX G SECOND STAGE
AXIAL SHEAR vs X-STATION**

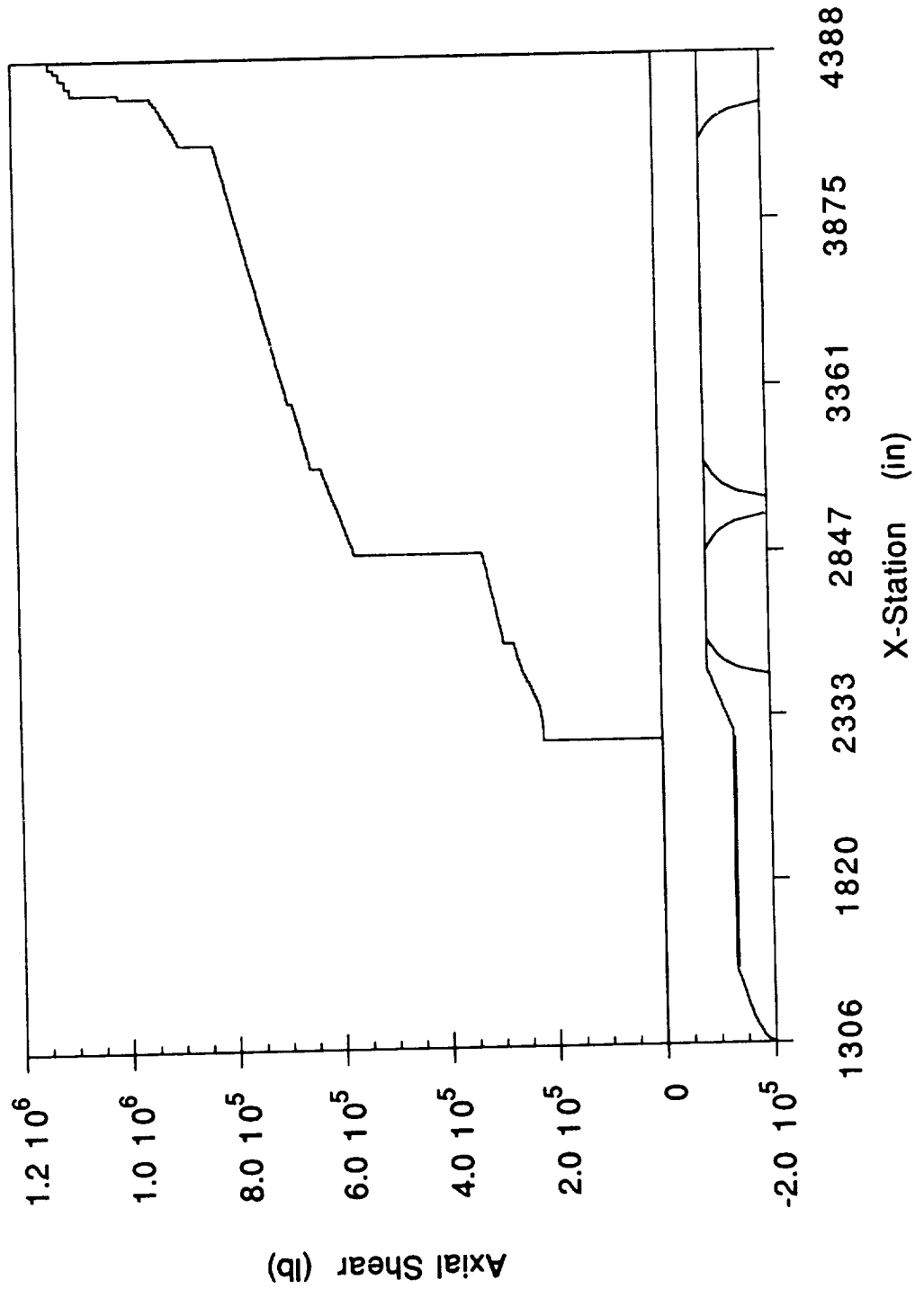

**NLS2 CORE - MAX G SECOND STAGE
Y-DIR SHEAR vs X-STATION**

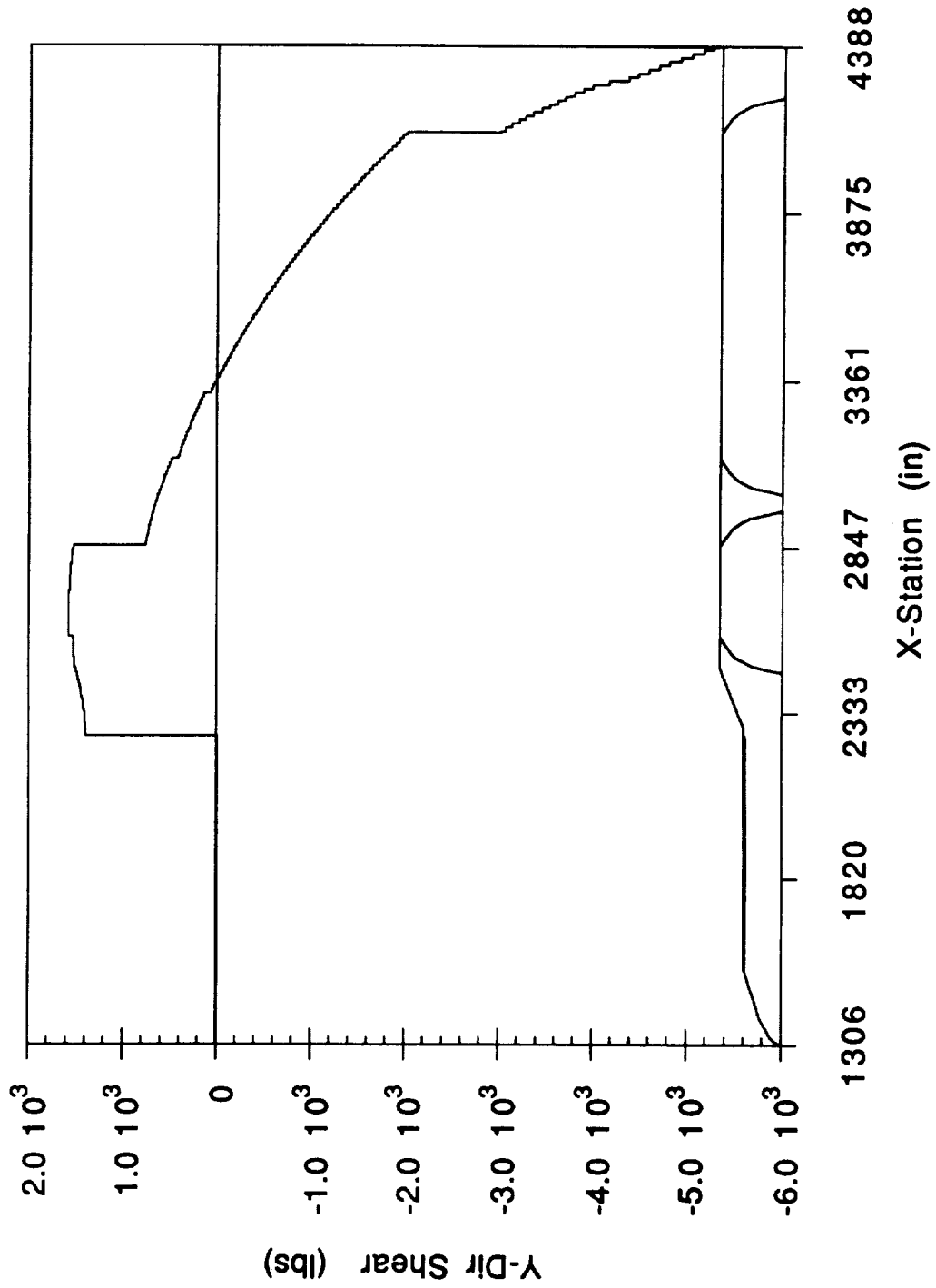

**NLS2 CORE - MAX G SECOND STAGE
Z-DIR SHEAR vs X-STATION**

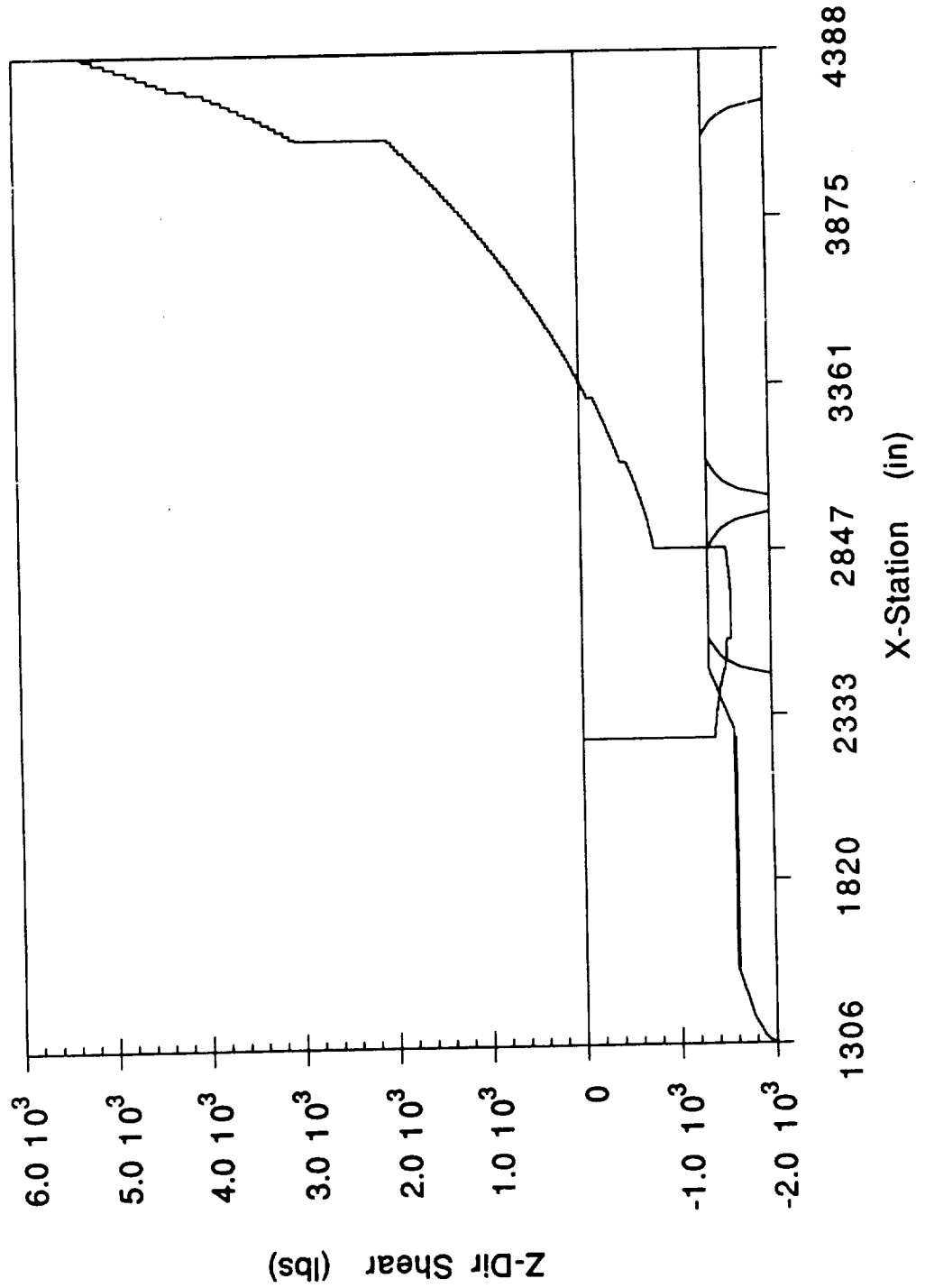

NLS2 CORE - MAX G SECOND STAGE Y-DIR MOMENT vs X-STATION

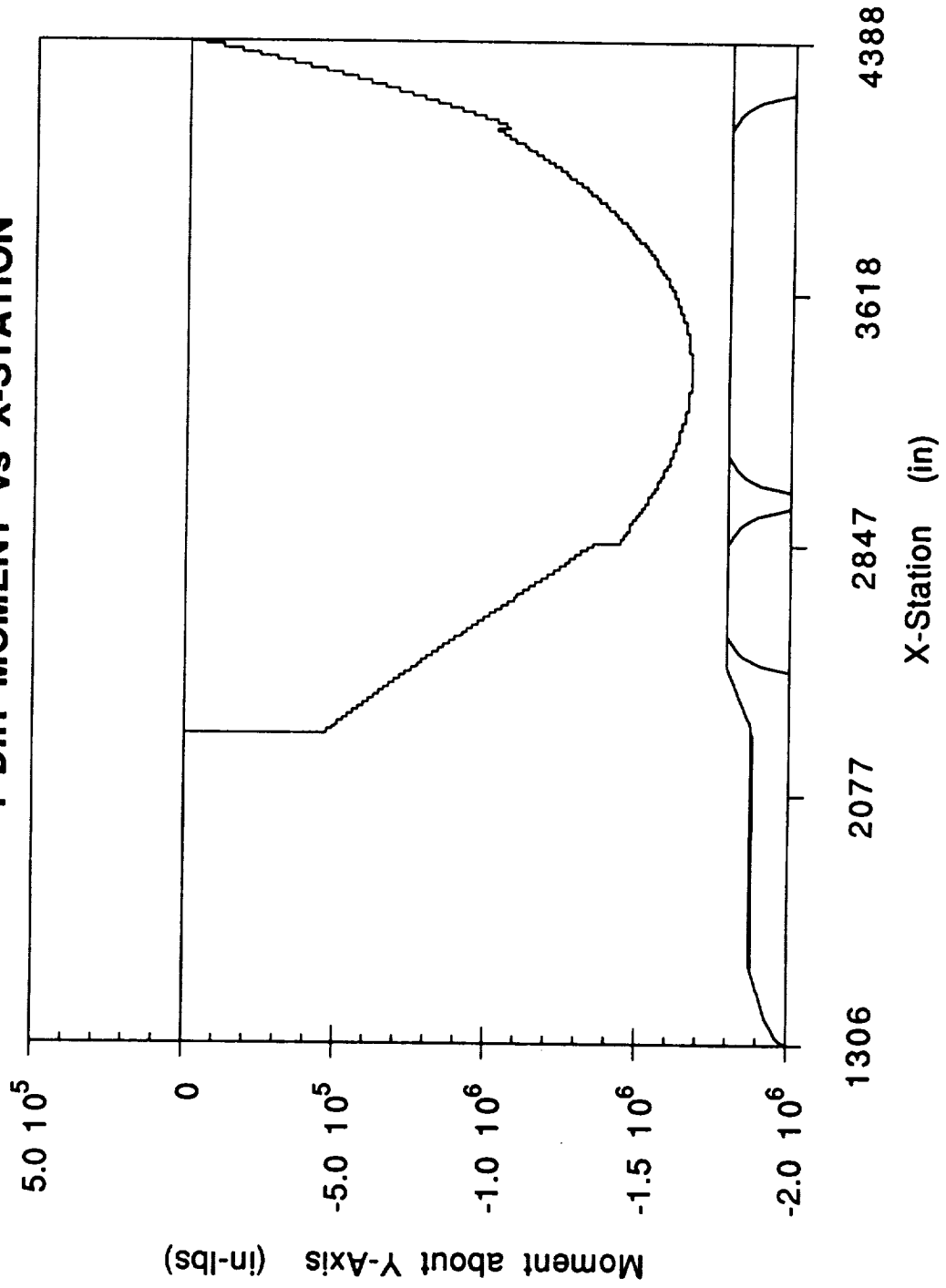

()

**NLS2 CORE - MAX G SECOND STAGE
Z-DIR MOMENT vs X-STATION**

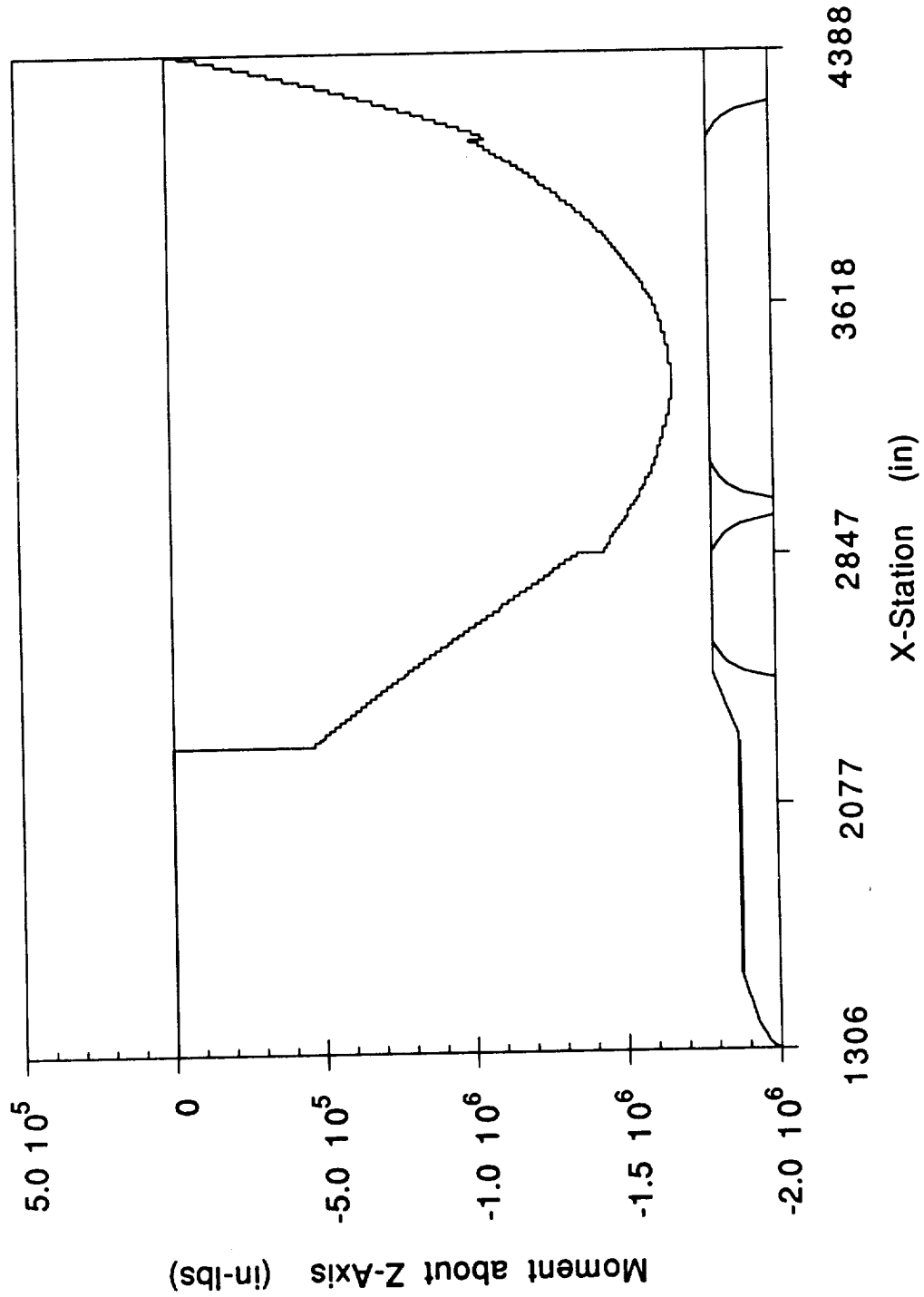

NLS2 CORE MAX G SECOND STAGE P EQUIVALENT vs X-STATION

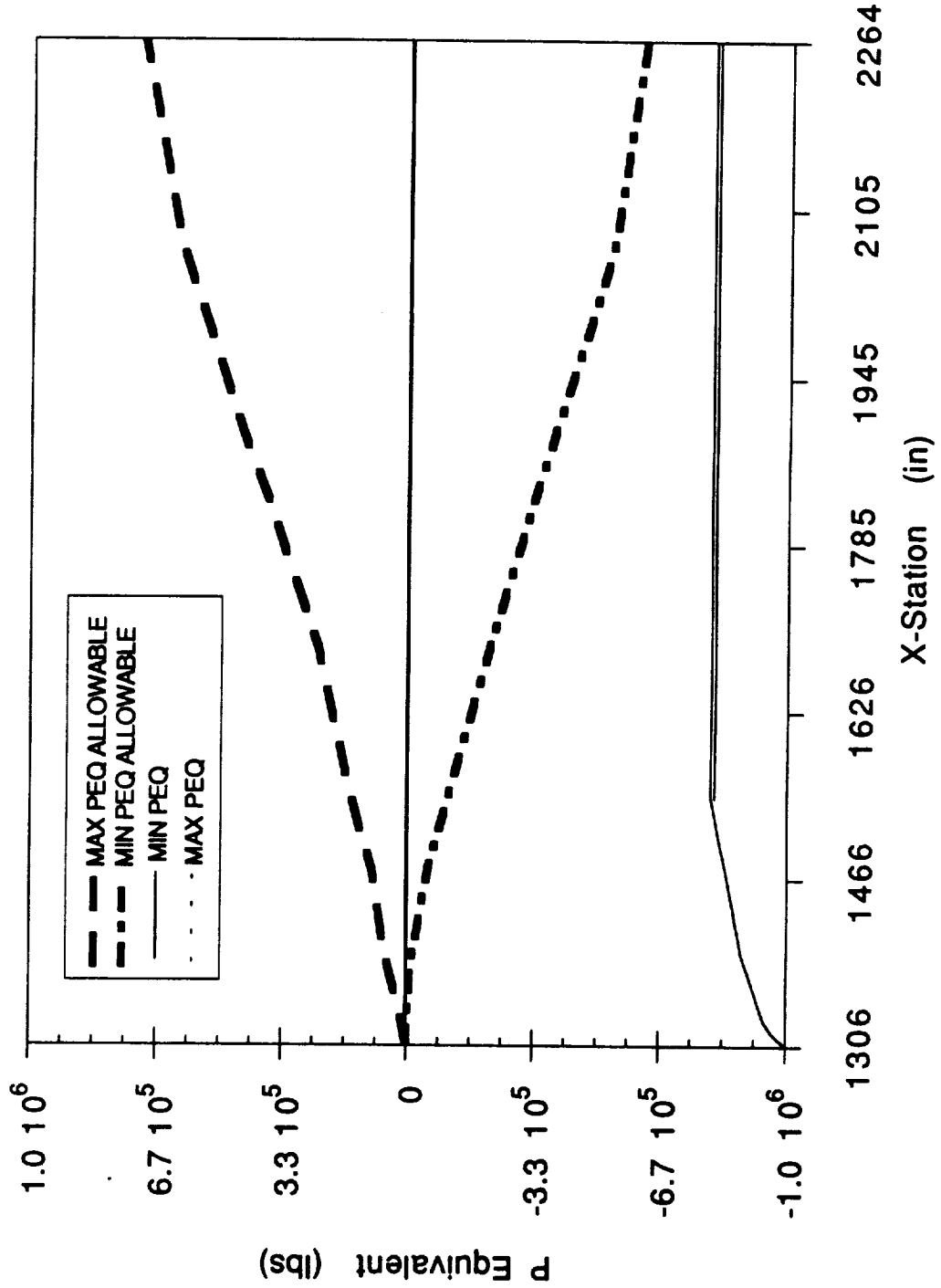

**NLS2 CORE MAX G SECOND STAGE
V EQUIVALENT vs X-STATION**

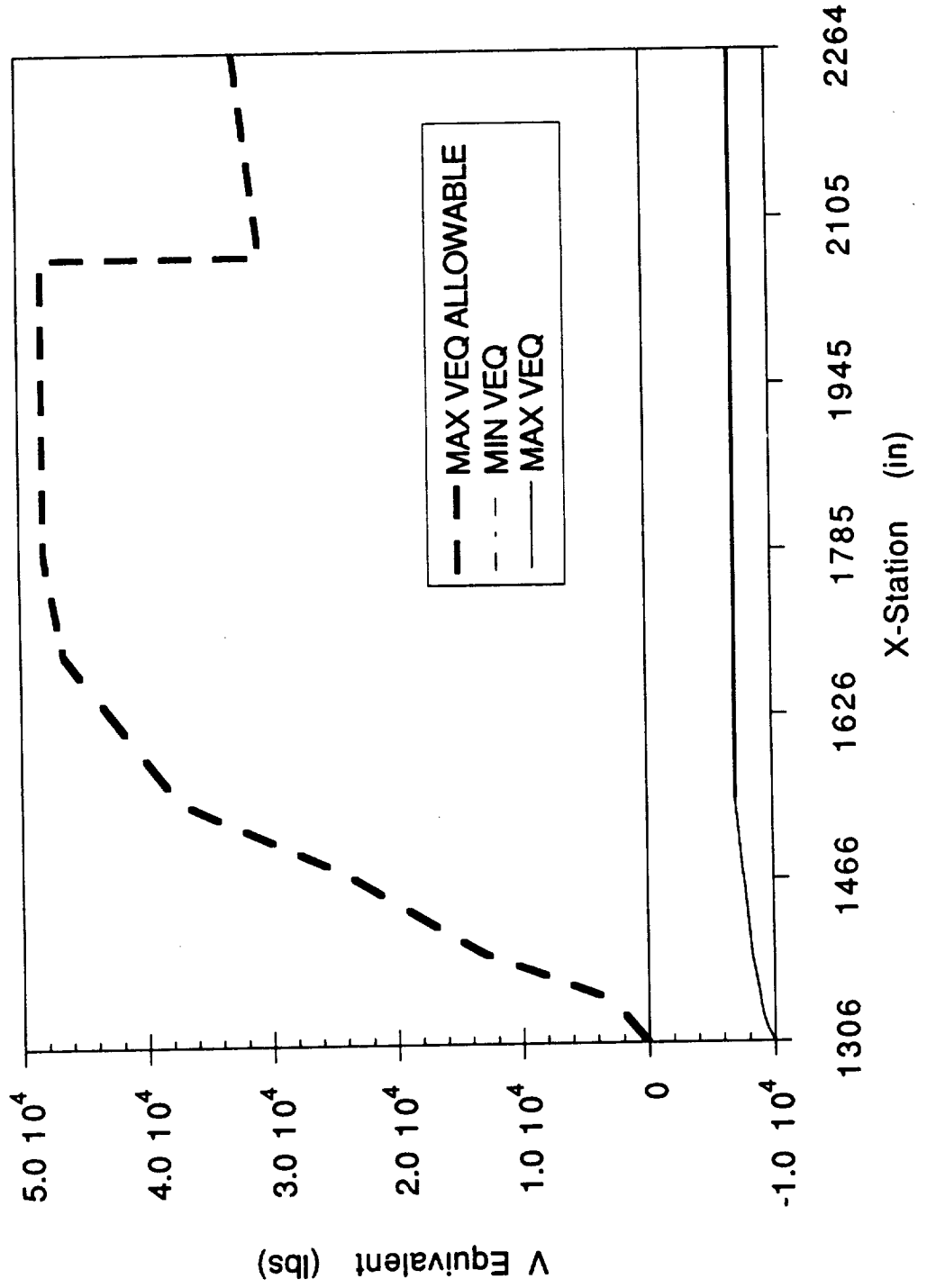

NLS2 CORE - ASCENT - ENGINE OUT OVERALL MAXIMUM NX

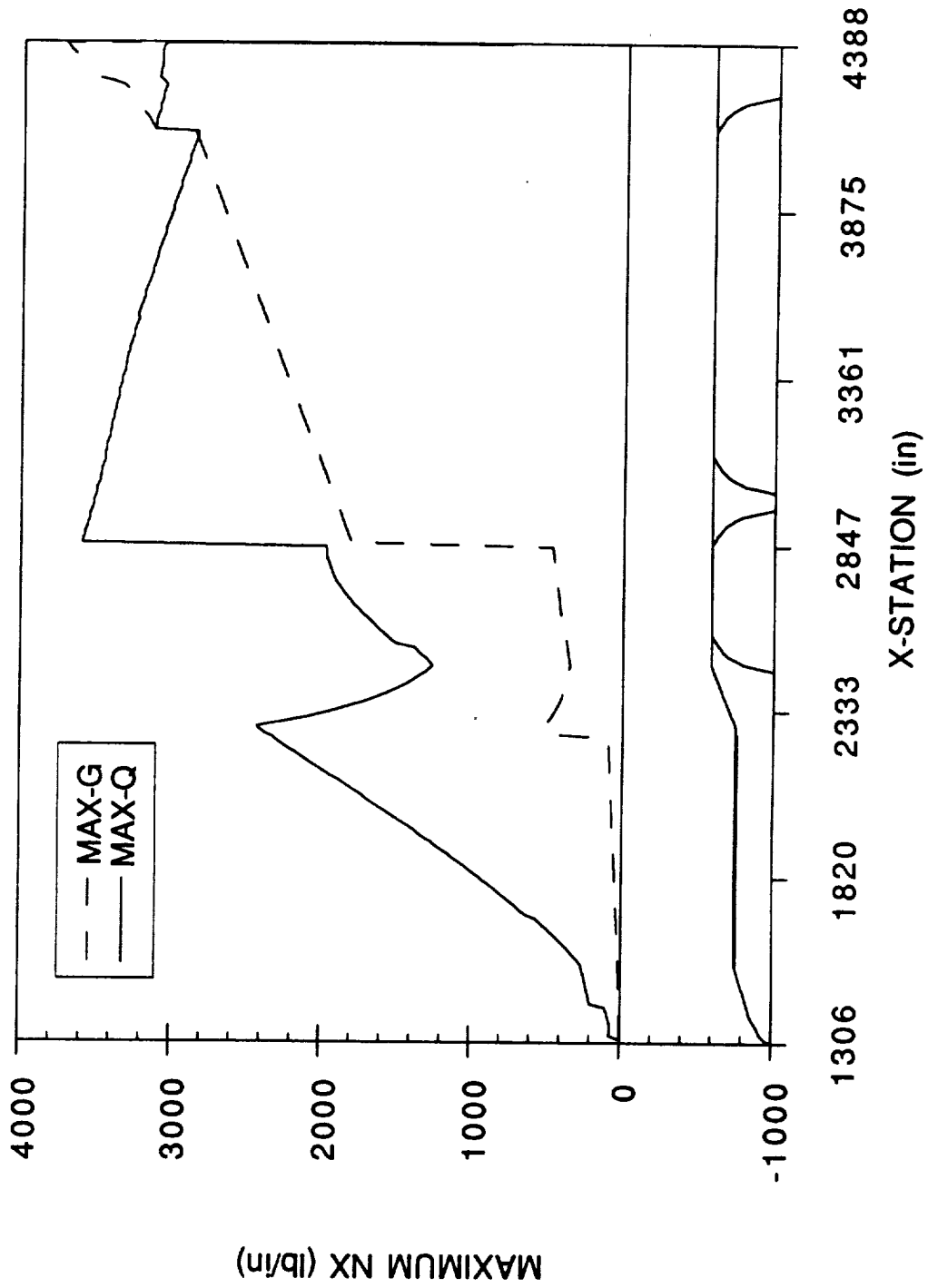

NLS2 CORE - ASCENT - ENGINE OUT
OVERALL MAXIMUM NV

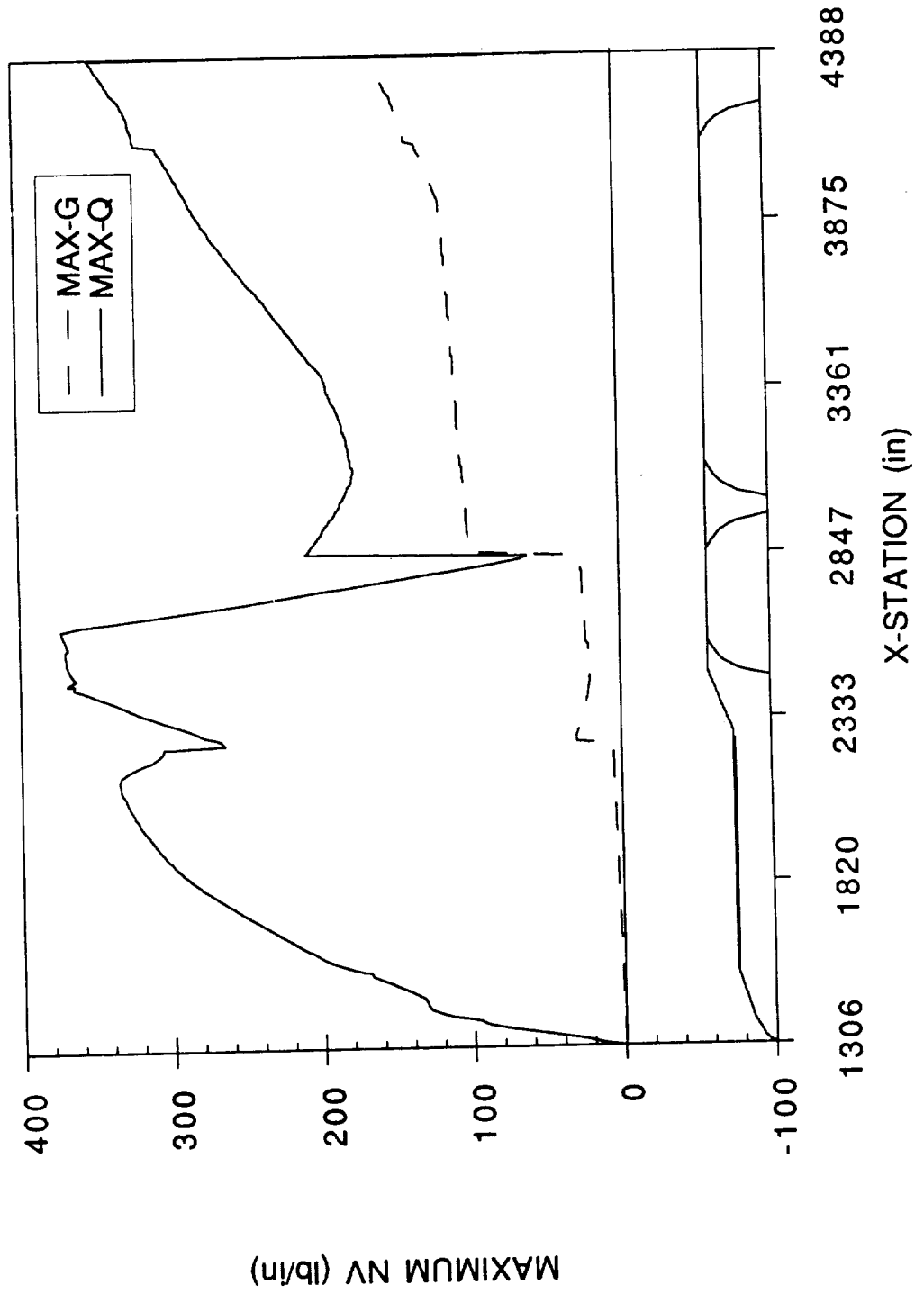

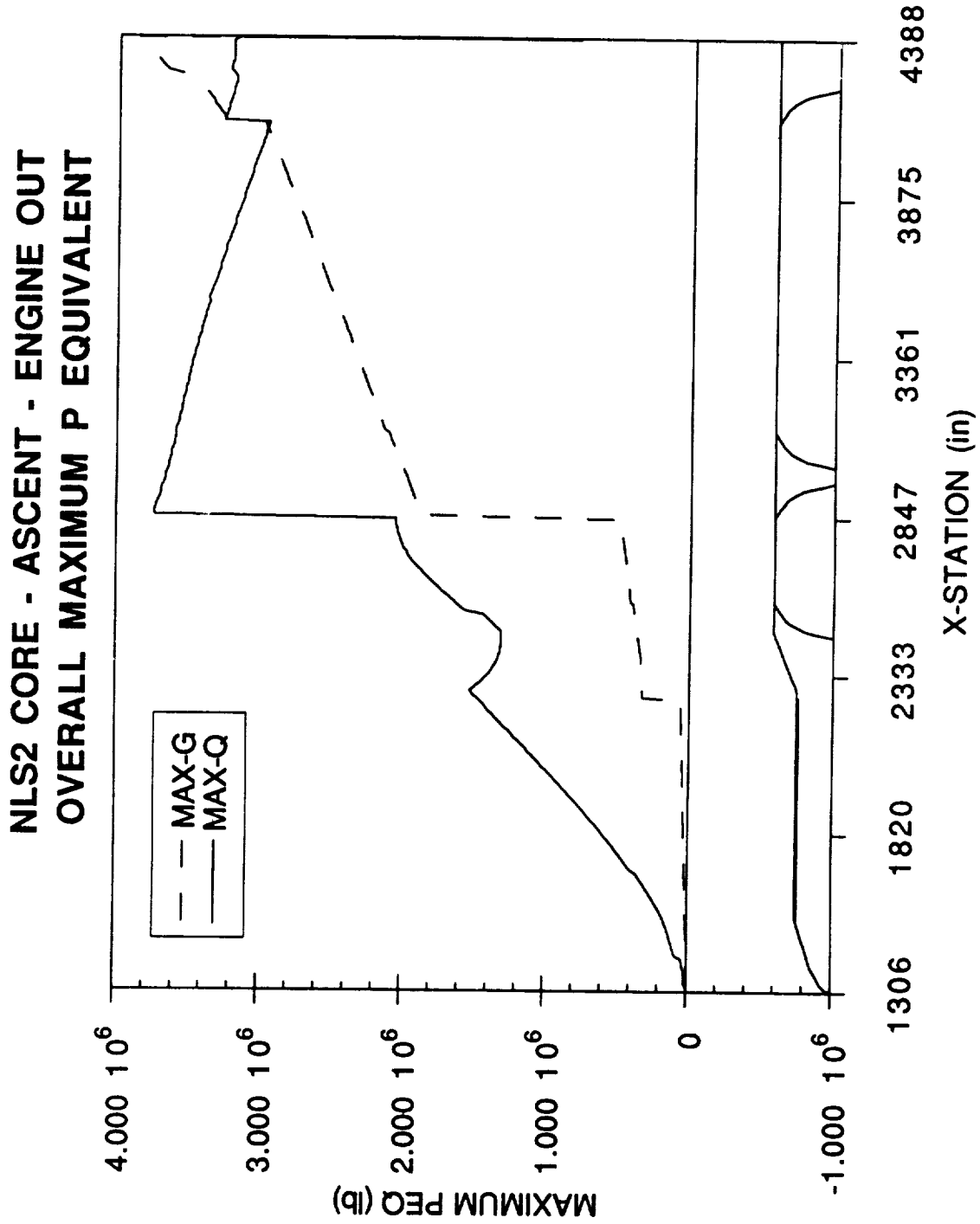

(((

**NLS2 CORE - ASCENT- ENGINE OUT
OVERALL MAXIMUM V EQUIVALENT**

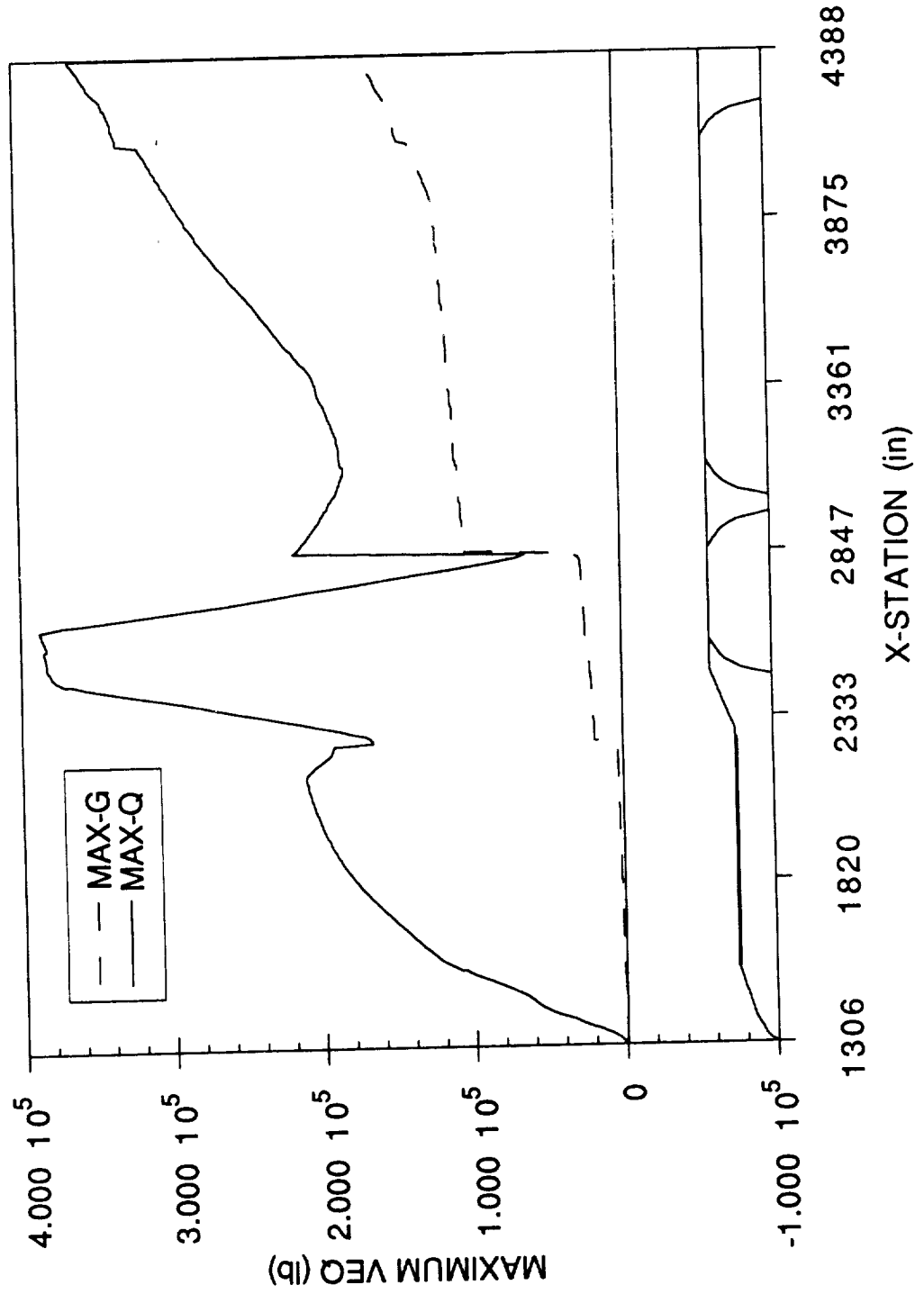

**NLS2 CORE - ASCENT - ENGINE OUT
OVERALL MAXIMUM AXIAL SHEAR**

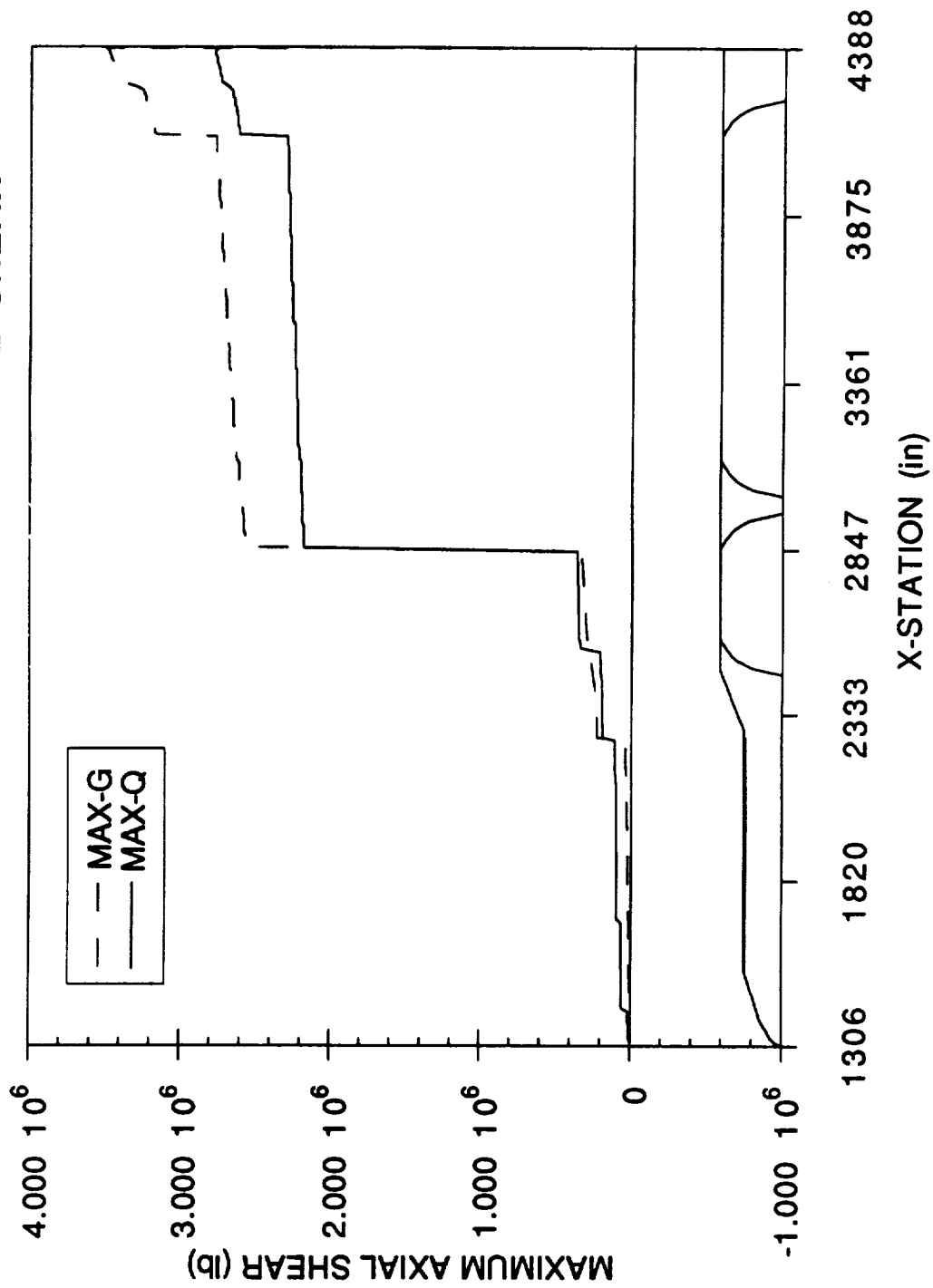

NLS2 CORE - ASCENT - ENGINE OUT
 OVERALL MAXIMUM SHEAR - Y DIRECTION

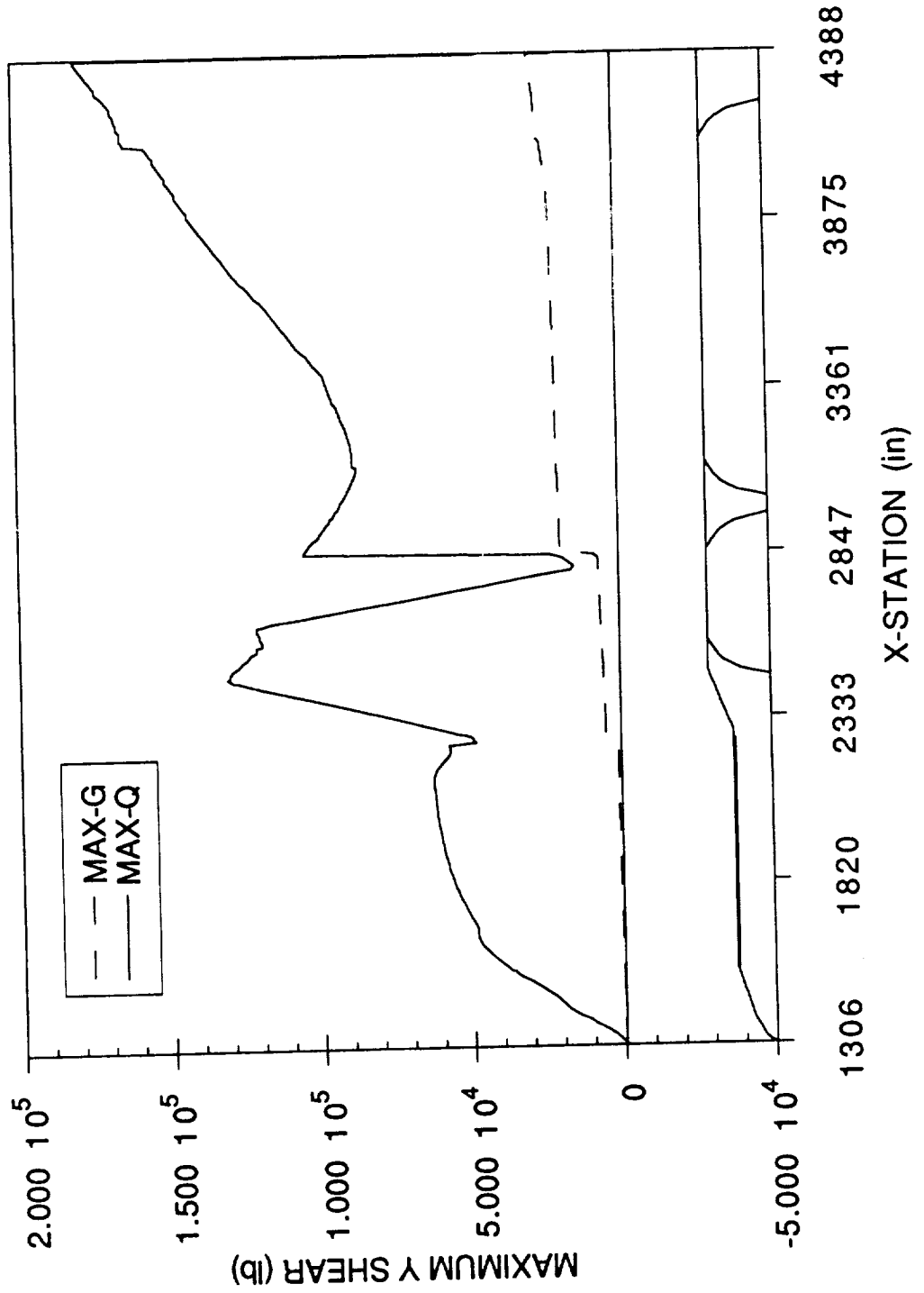

**NLS2 CORE - ASCENT - ENGINE OUT
OVERALL MAXIMUM SHEAR - Z DIRECTION**

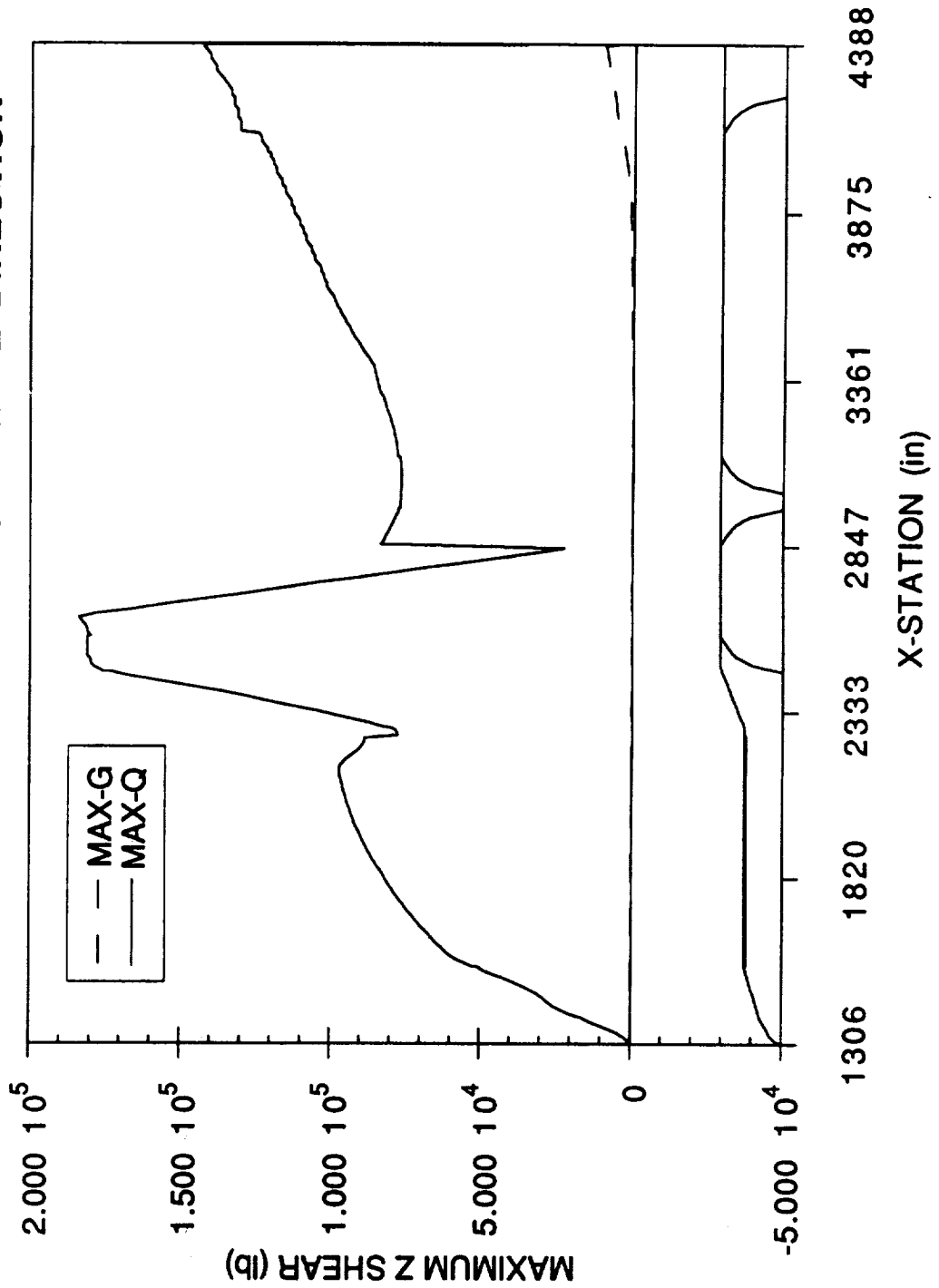

**NLS2 CORE - ASCENT - ENGINE OUT
OVERALL MAXIMUM MOMENT - Y DIRECTION**

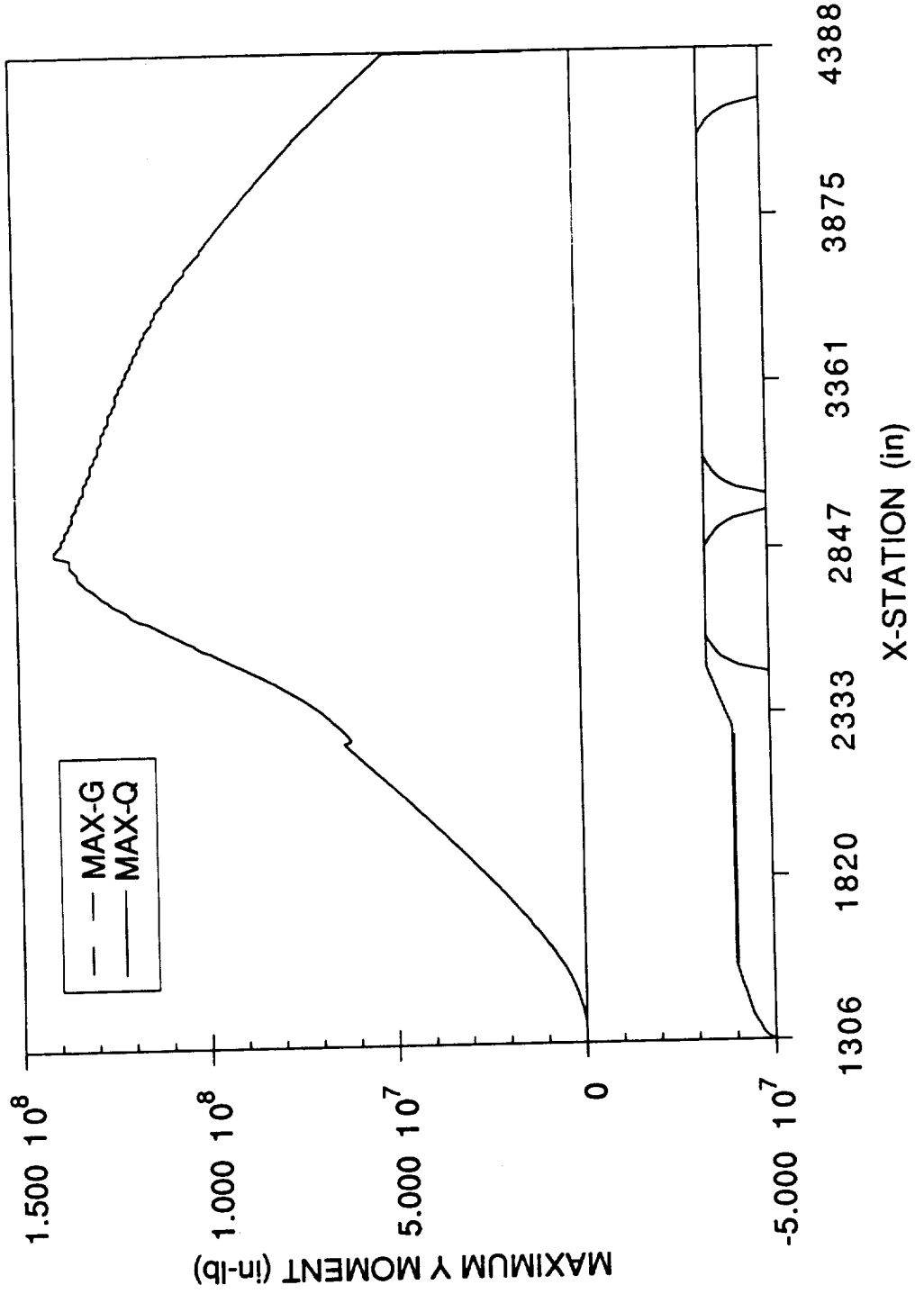

NLS2 CORE - ASCENT - ENGINE OUT OVERALL MAXIMUM MOMENT - Z DIRECTION

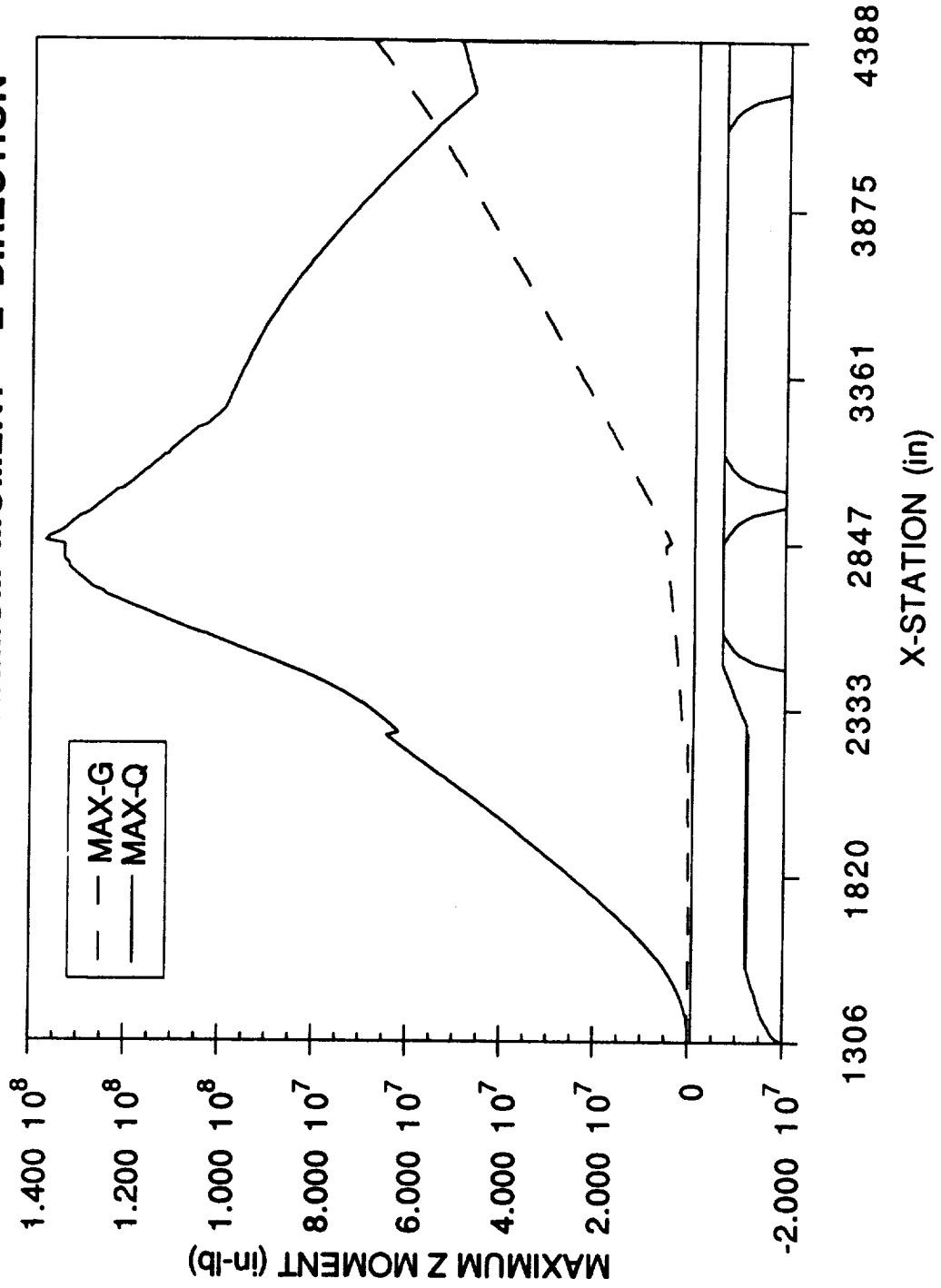

(((

NLS2 CORE - 6 km ENGINE OUT NX vs X-STATION

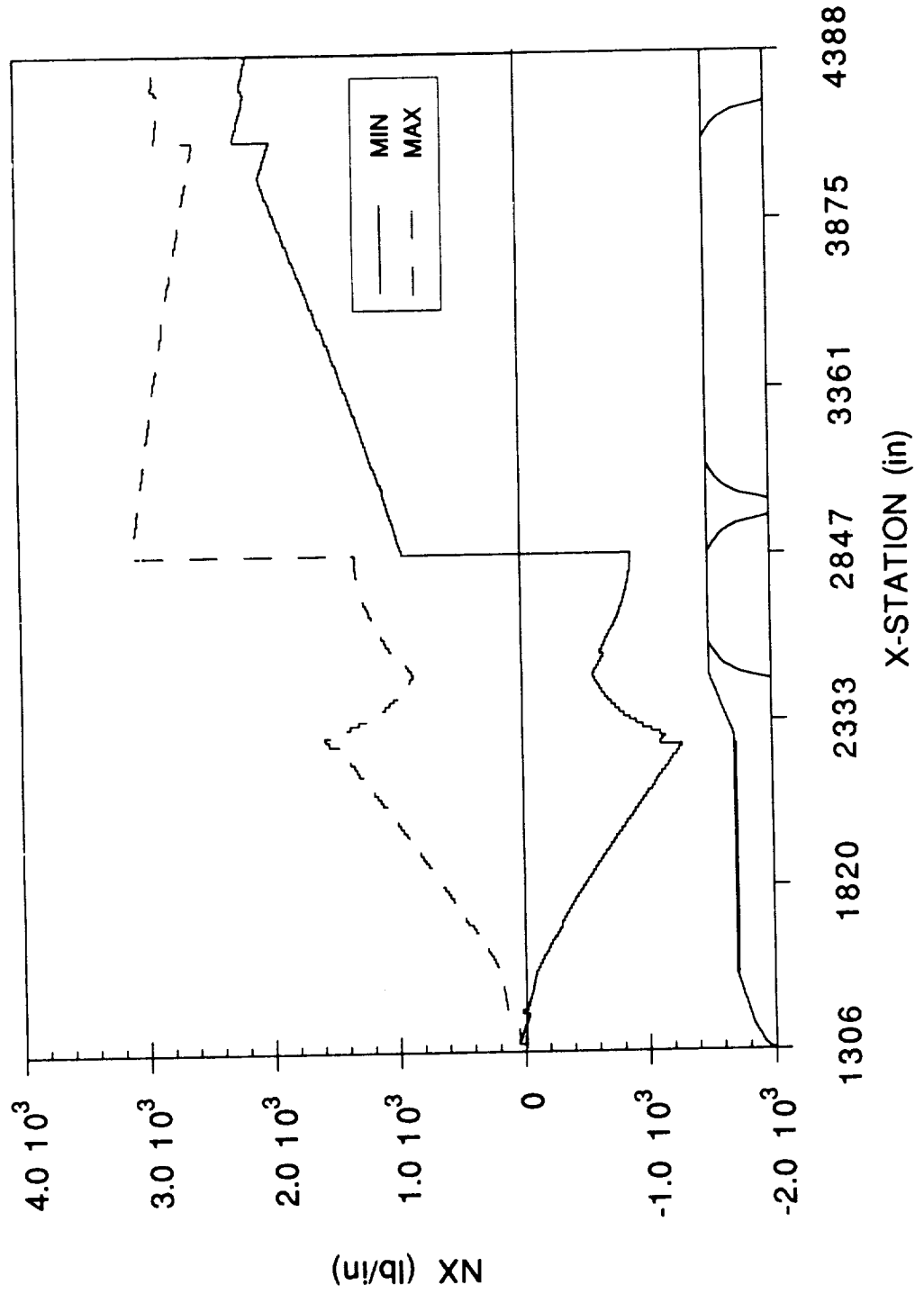

NLS2 CORE - 6 km ENGINE OUT NV vs X-STATION

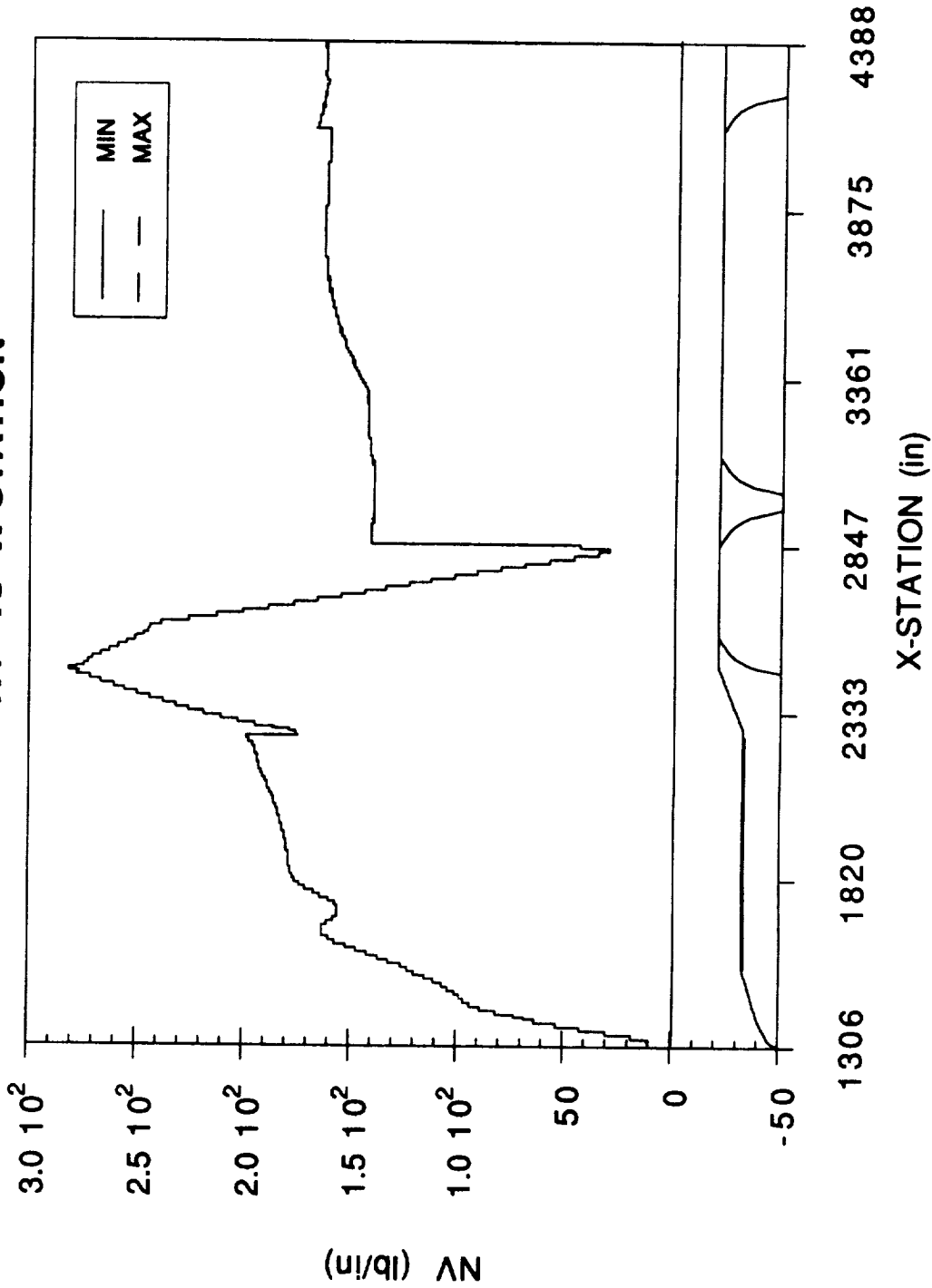

(((

**NLS2 CORE - 6 km ENGINE OUT
AXIAL SHEAR vs X-STATION**

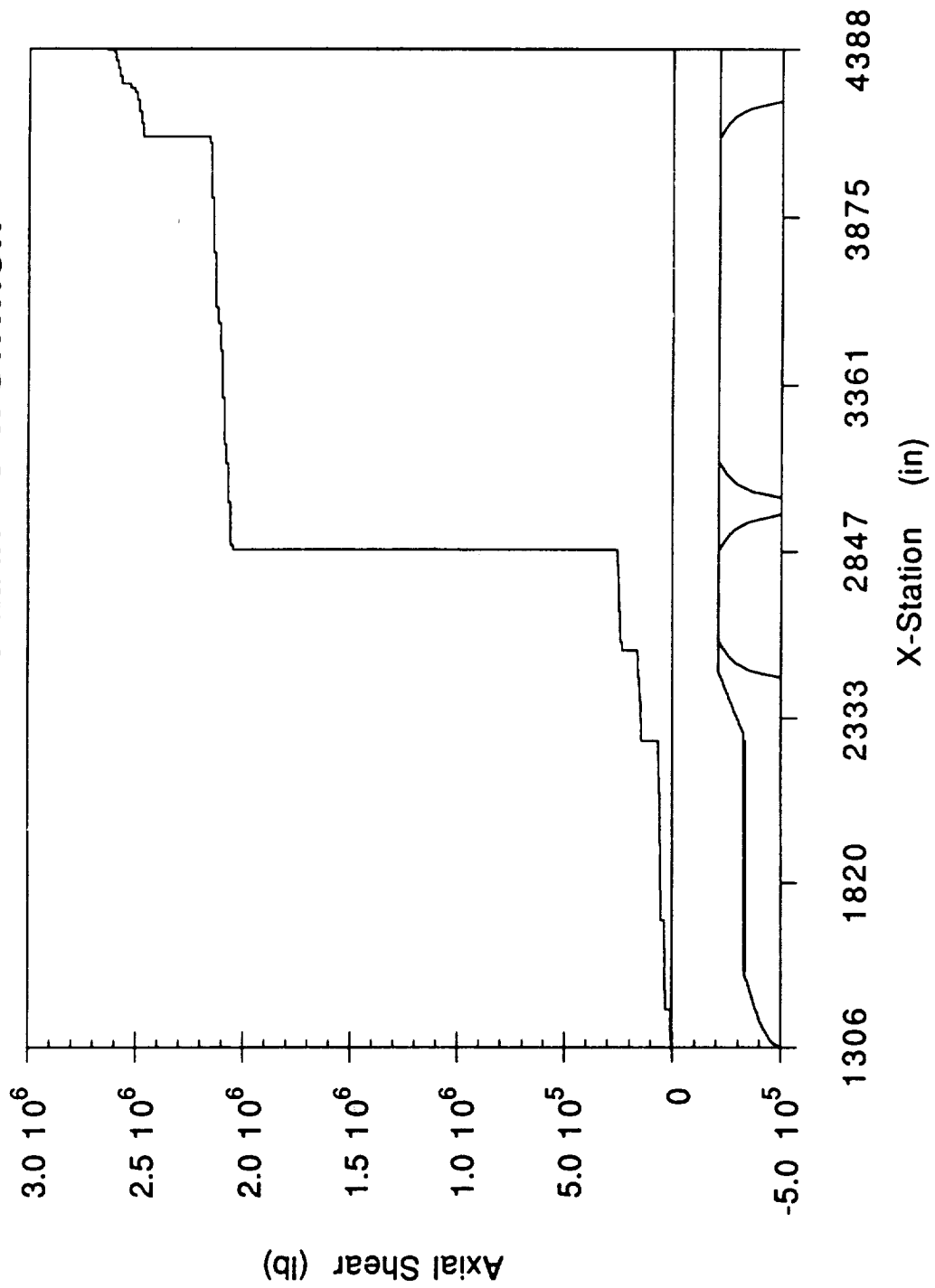

**NLS2 CORE - 6 km ENGINE OUT
Y-DIR SHEAR vs X-STATION**

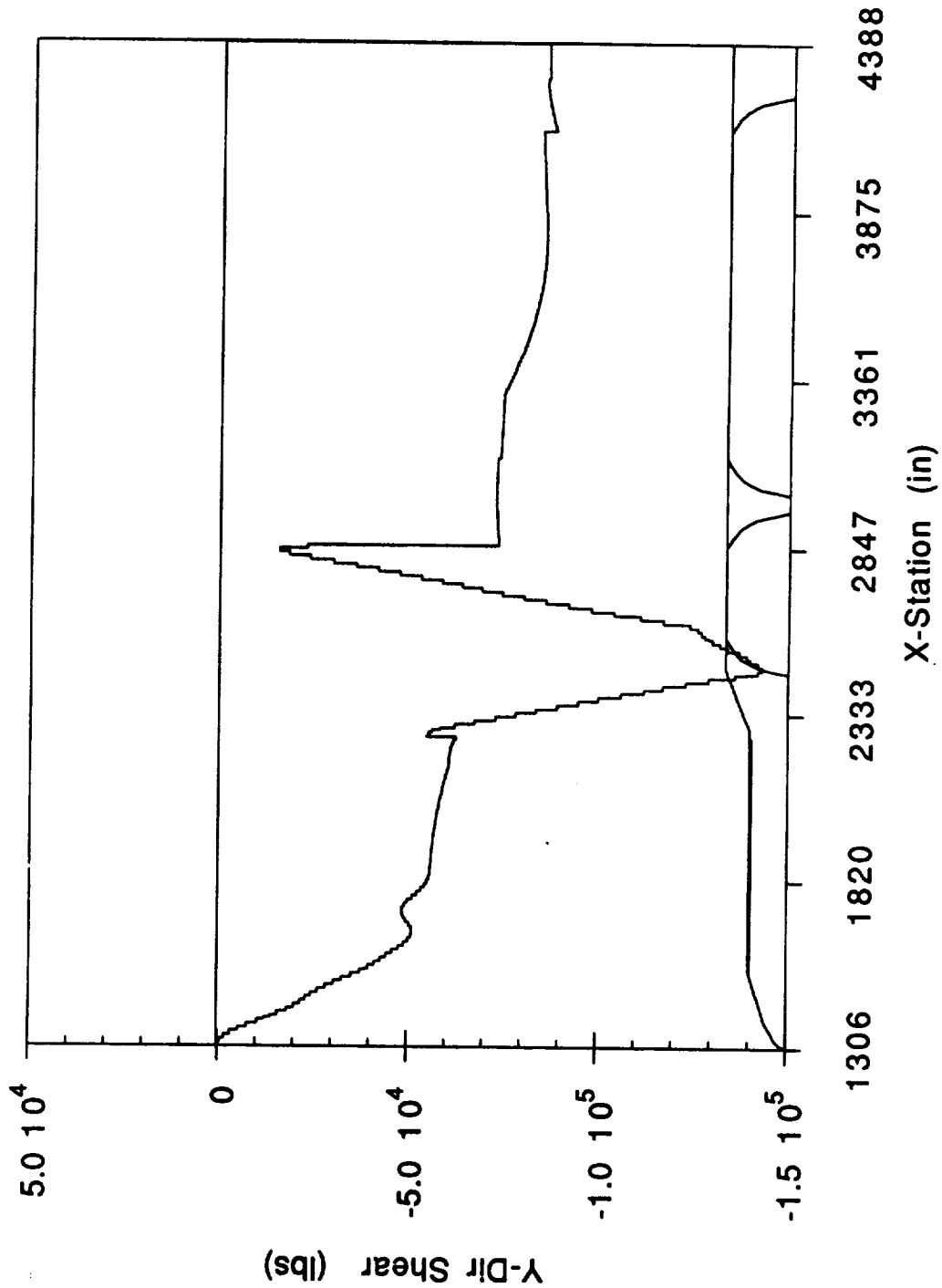

**NLS2 CORE - 6 km ENGINE OUT
Z-DIR SHEAR vs X-STATION**

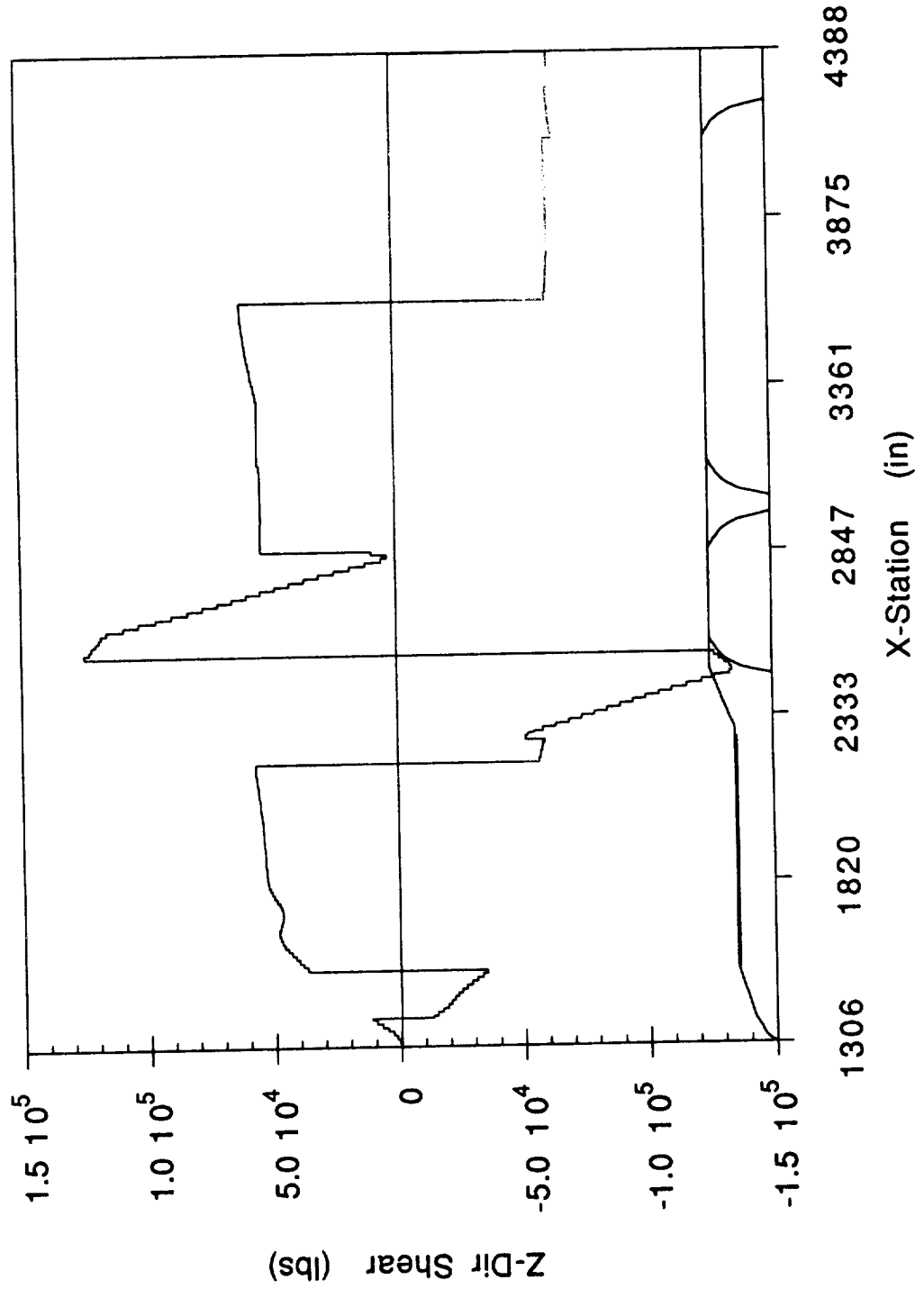

NLS2 CORE - 6 km ENGINE OUT Y-DIR MOMENT vs X-STATION

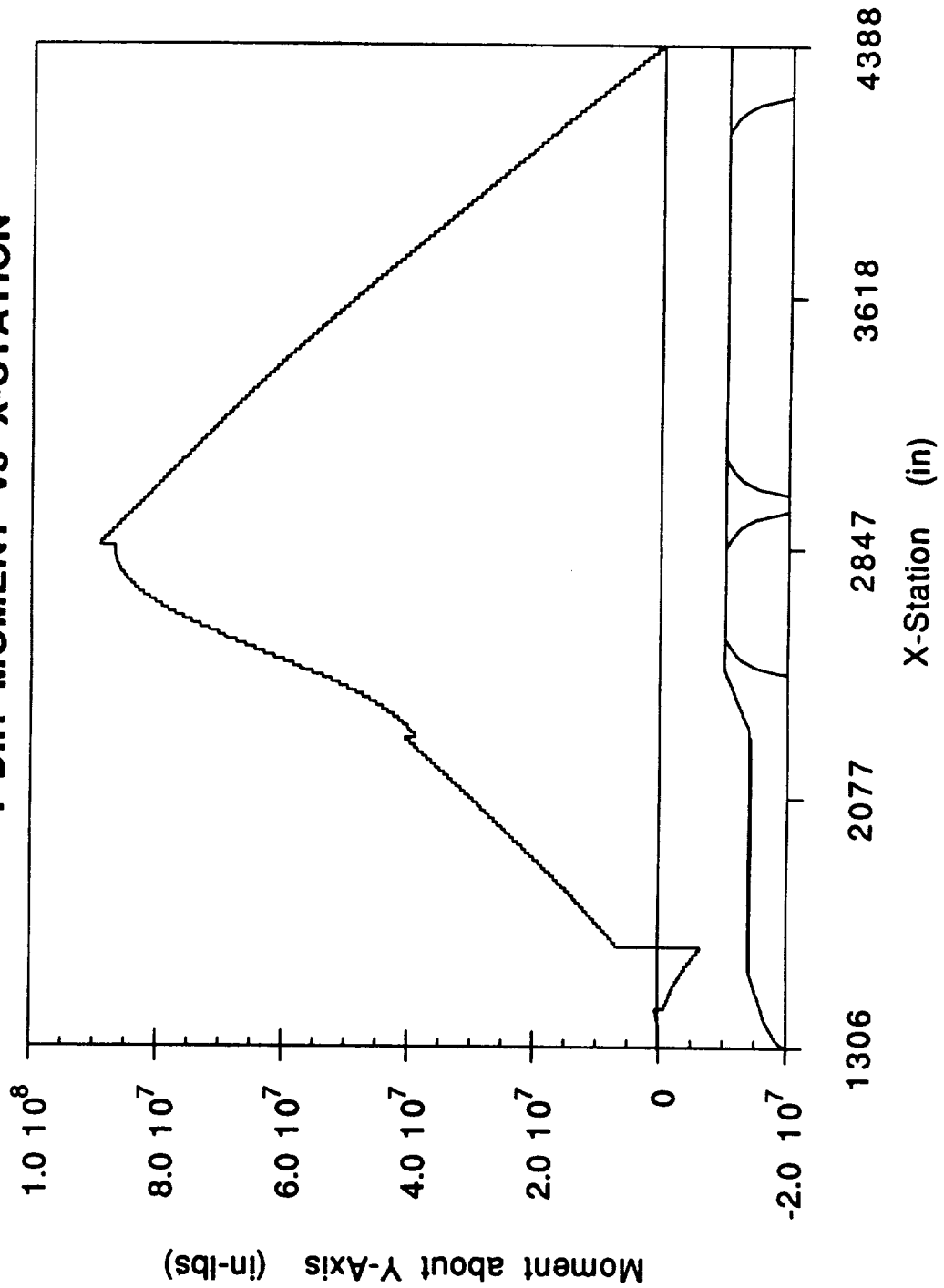

() ()

**NLS2 CORE - 6 km ENGINE OUT
Z-DIR MOMENT vs X-STATION**

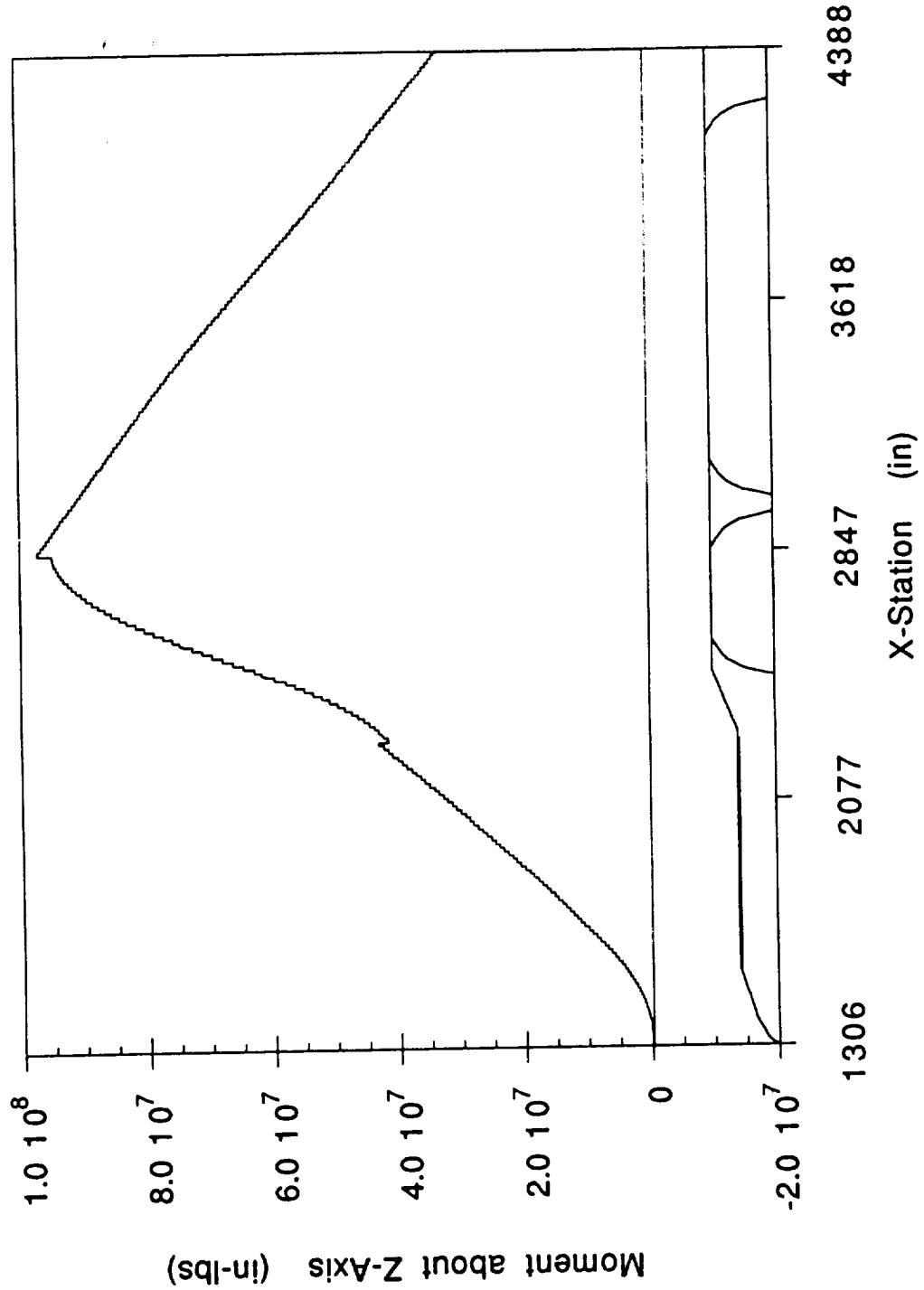

NLS2 CORE 6 km ENGINE OUT P EQUIVALENT vs X-STATION

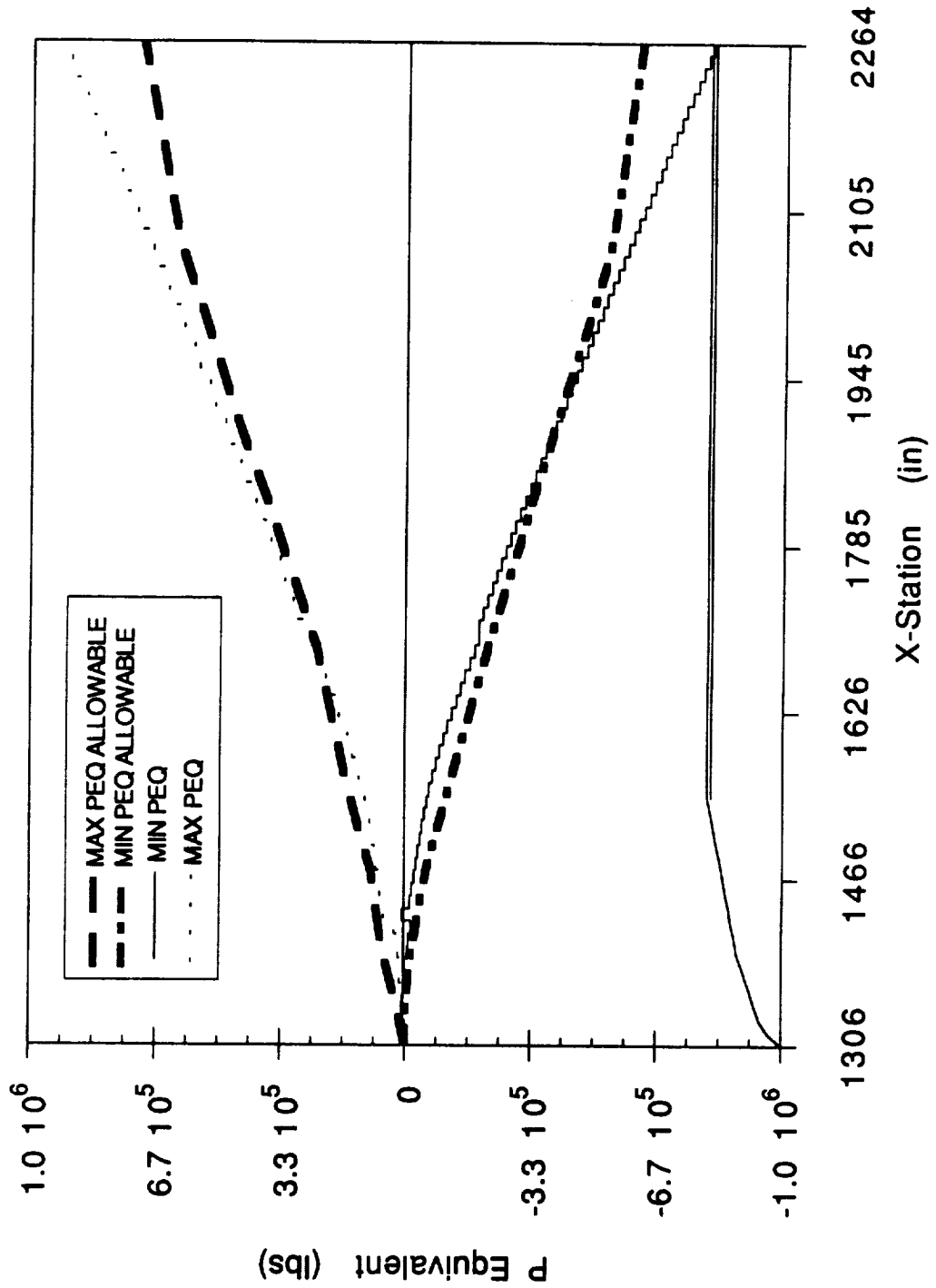

**NLS2 CORE 6 km ENGINE OUT
V EQUIVALENT vs X-STATION**

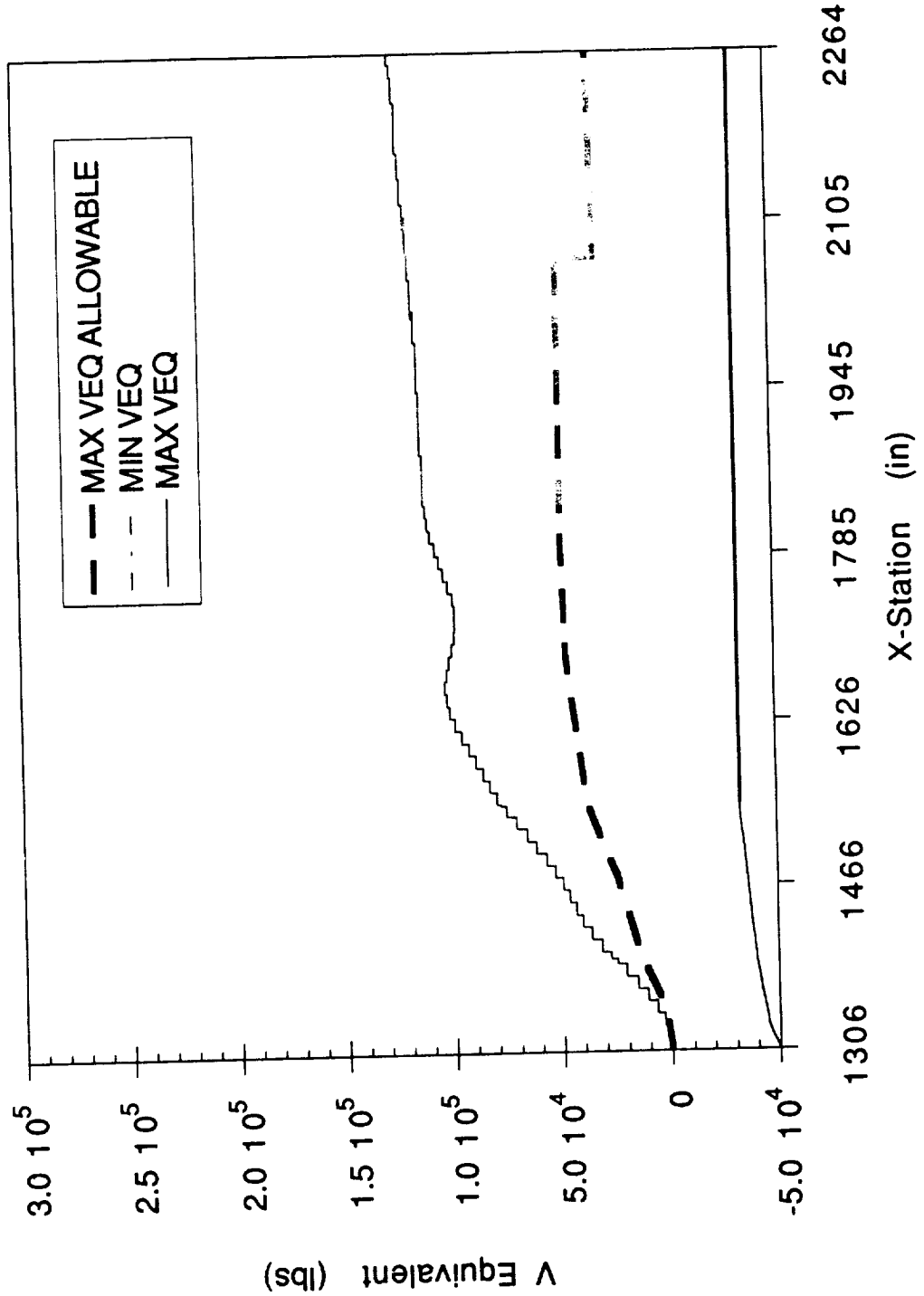

**NLS2 CORE - 8km ENGINE OUT
NX vs X-STATION**

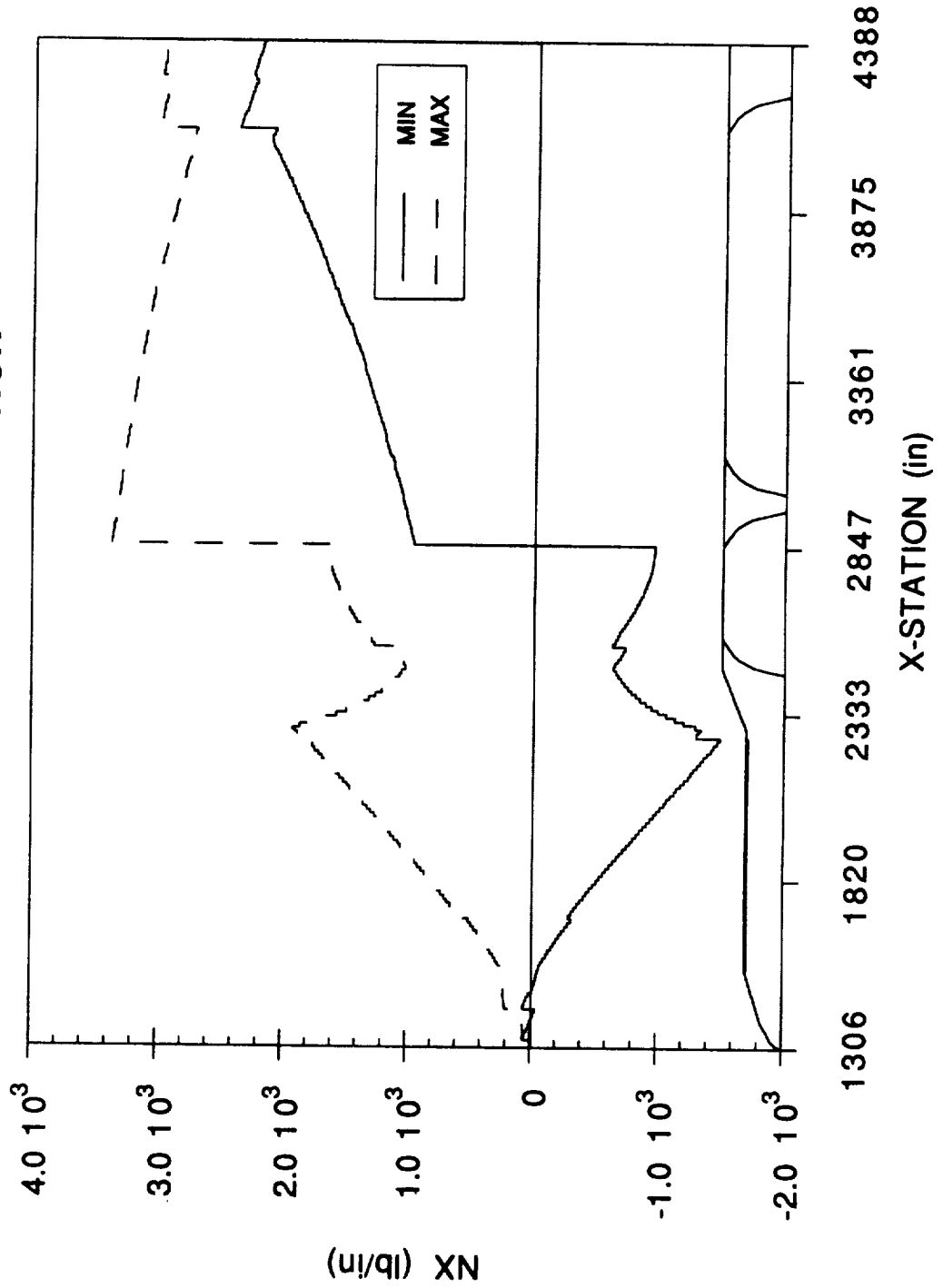

**NLS2 CORE -8 km ENGINE OUT
NV vs X-STATION**

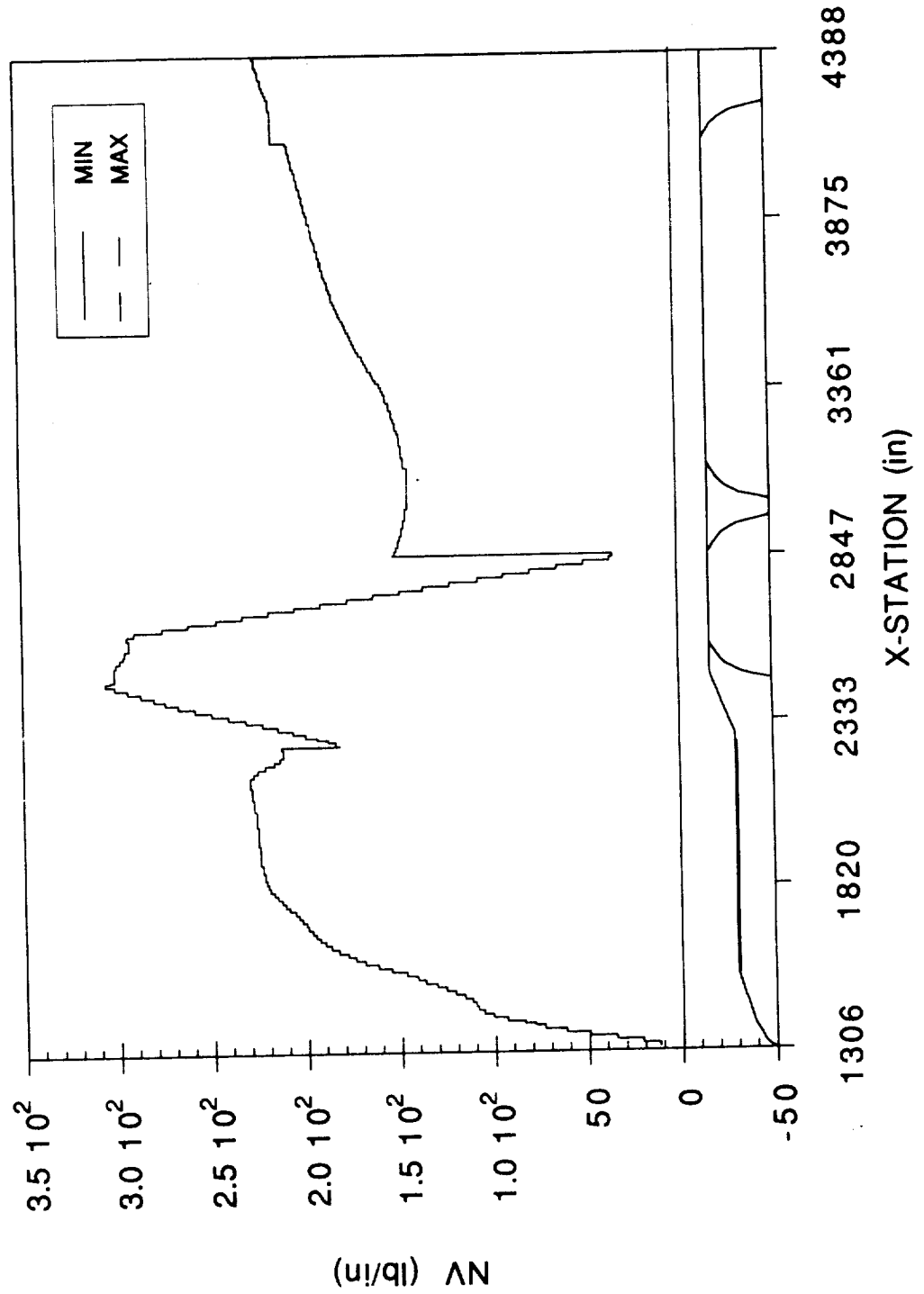

NLS2 CORE - 8 km ENGINE OUT AXIAL SHEAR vs X-STATION

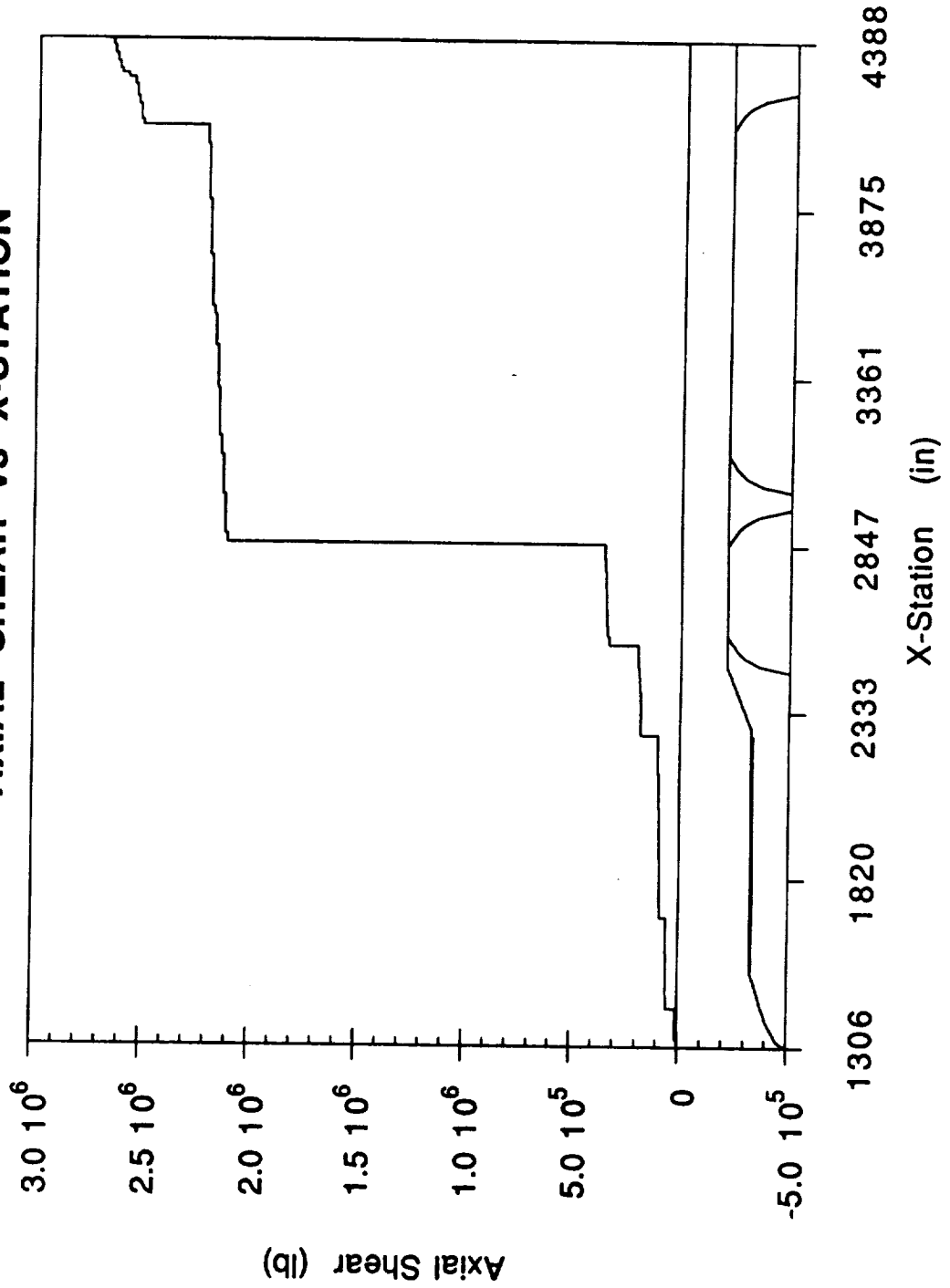

((

**NLS2 CORE - 8 km ENGINE OUT
Y-DIR SHEAR vs X-STATION**

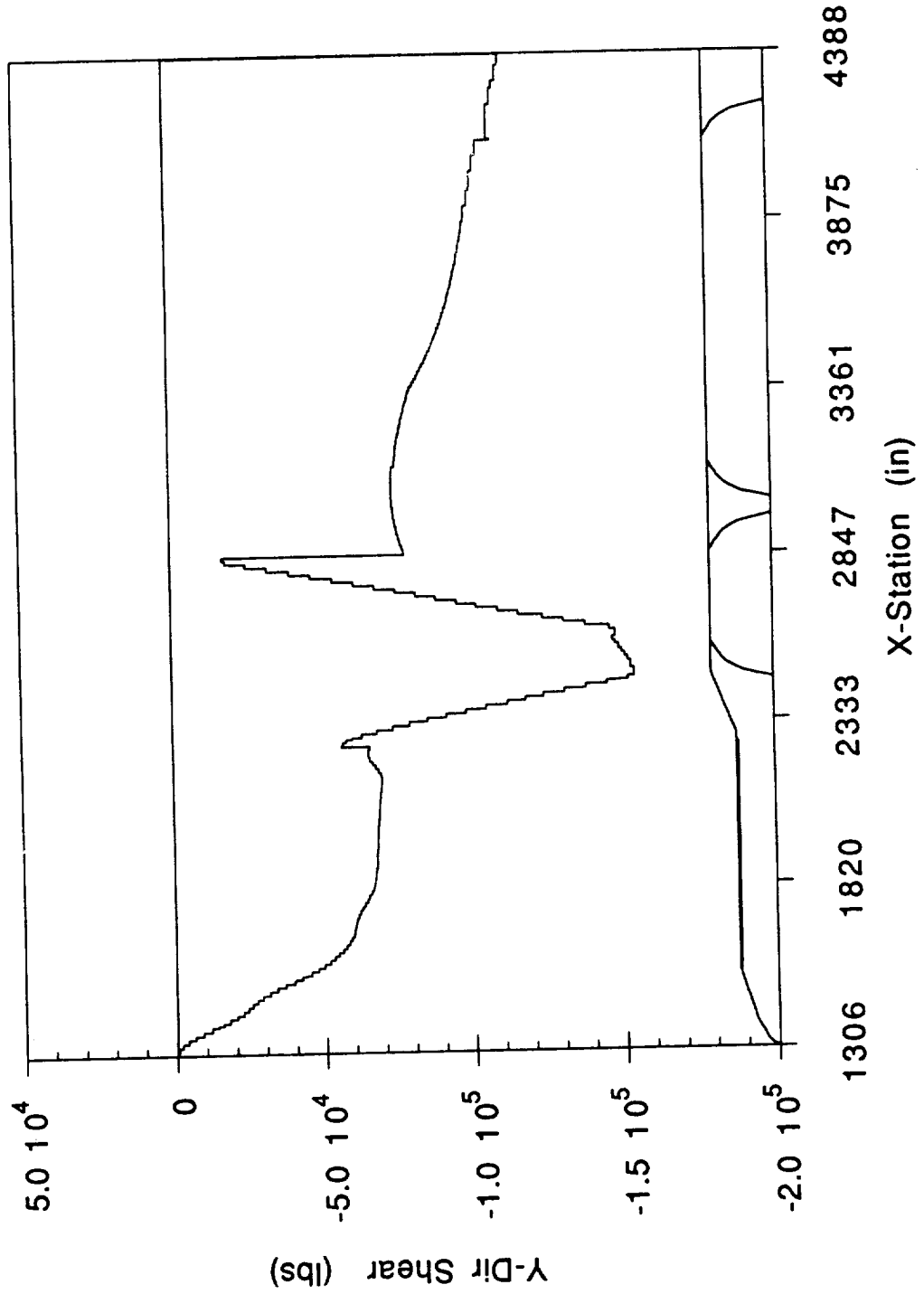

**NLS2 CORE - 8 km ENGINE OUT
Z-DIR SHEAR vs X-STATION**

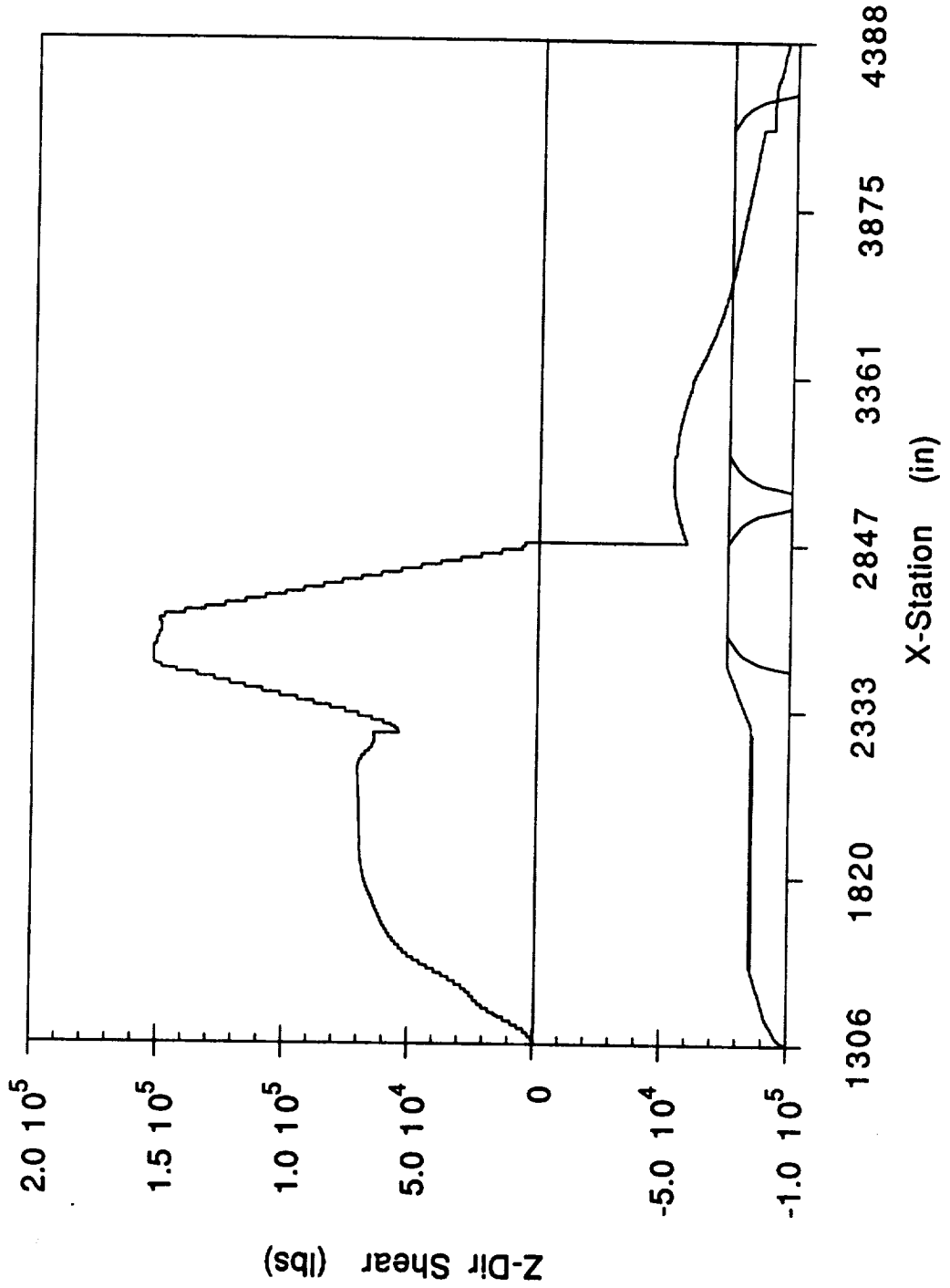

((

**NLS2 CORE - 8 km ENGINE OUT
Y-DIR MOMENT vs X-STATION**

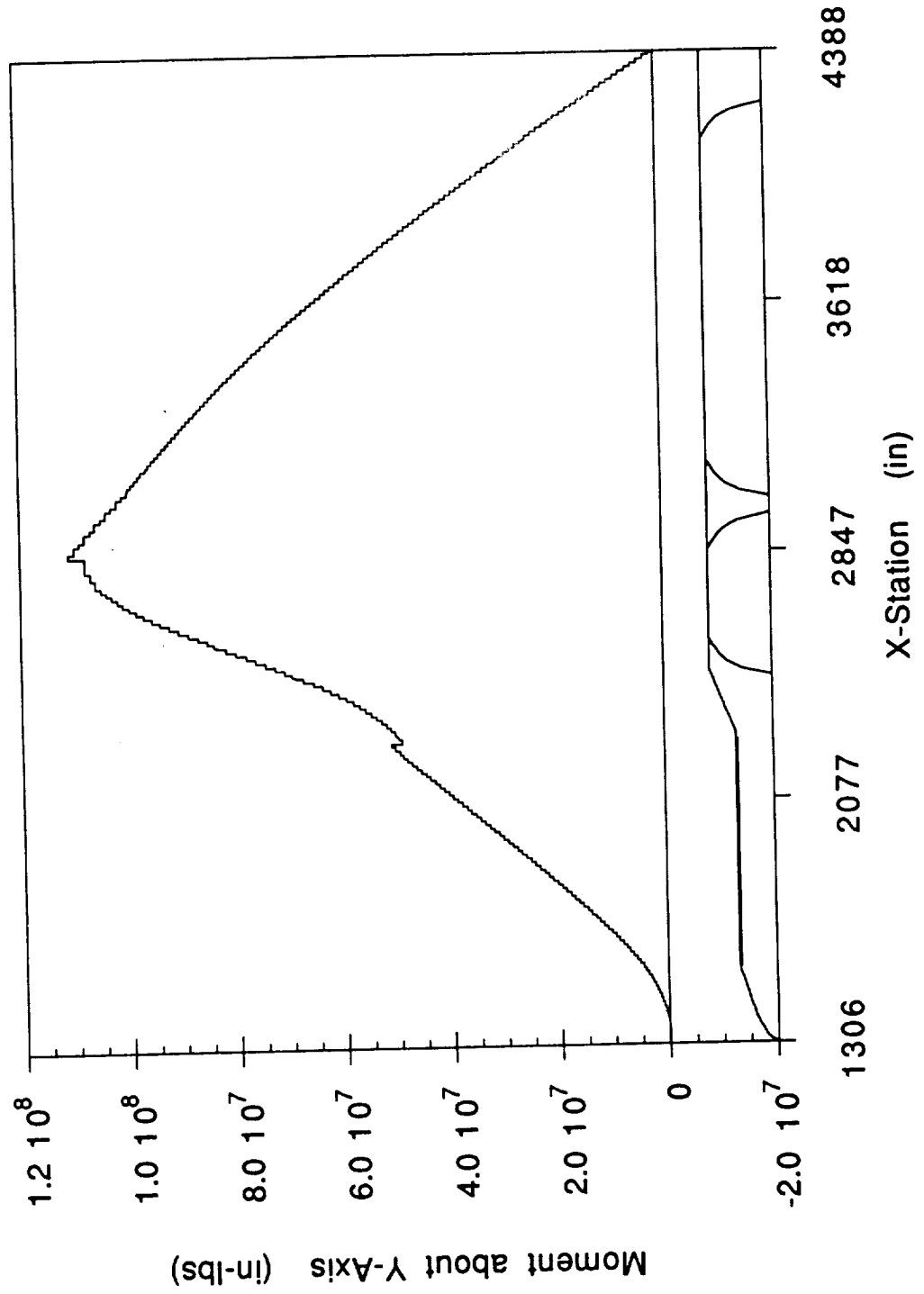

NLS2 CORE - 8 km ENGINE OUT Z-DIR MOMENT vs X-STATION

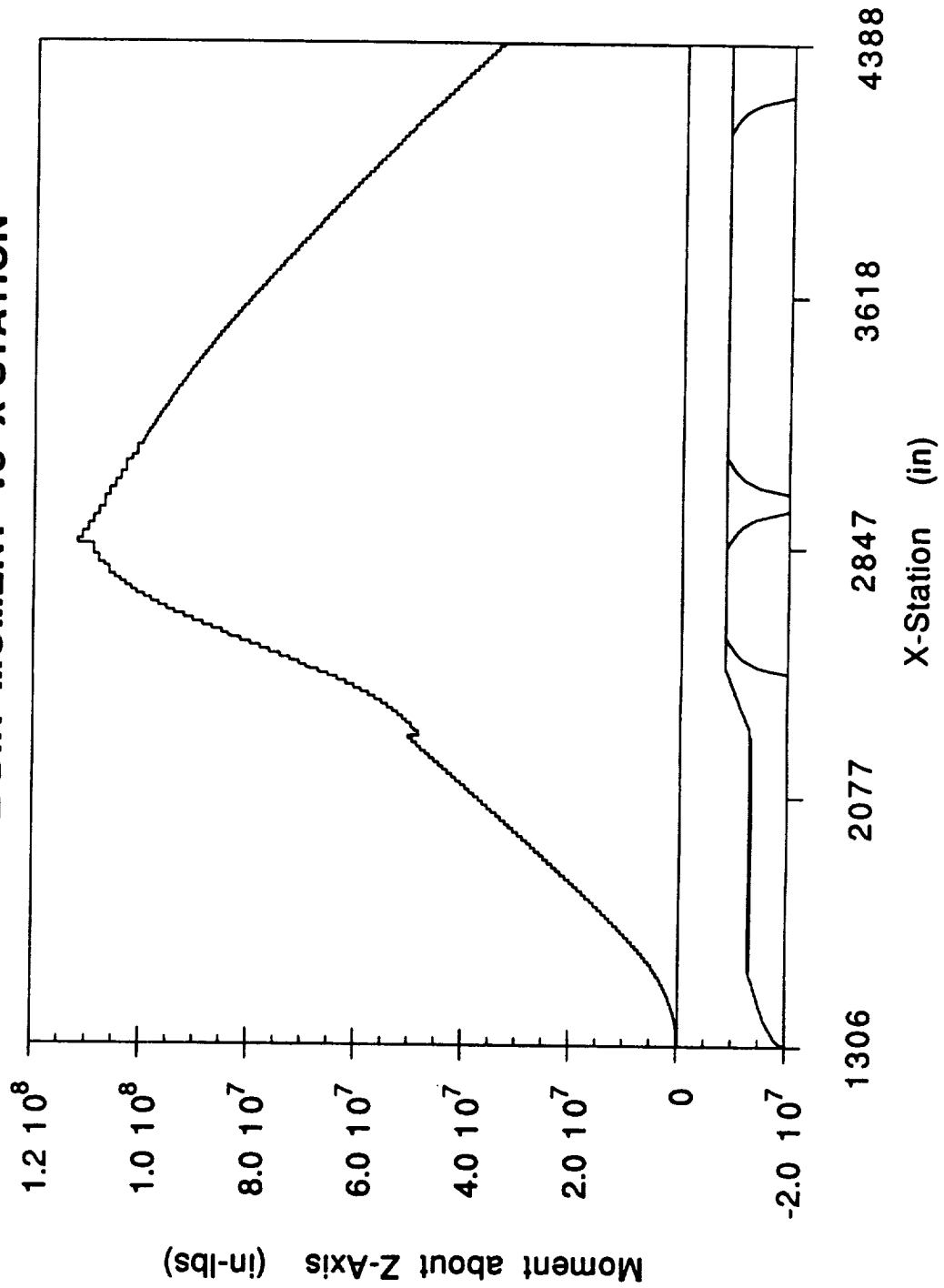

NLS2 CORE 8 km ENGINE OUT P EQUIVALENT vs X-STATION

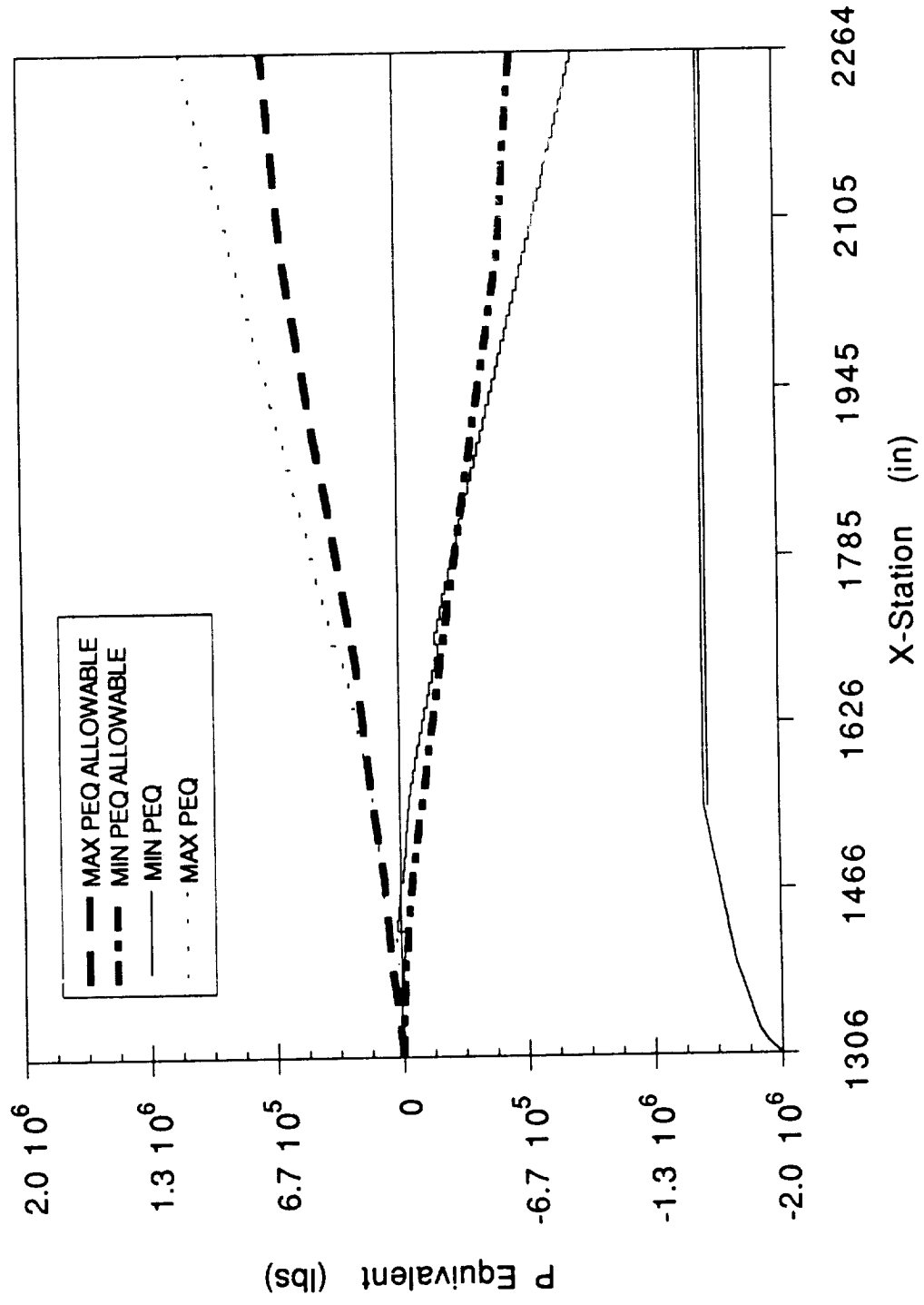

**NLS2 CORE 8 km ENGINE OUT
V EQUIVALENT vs X-STATION**

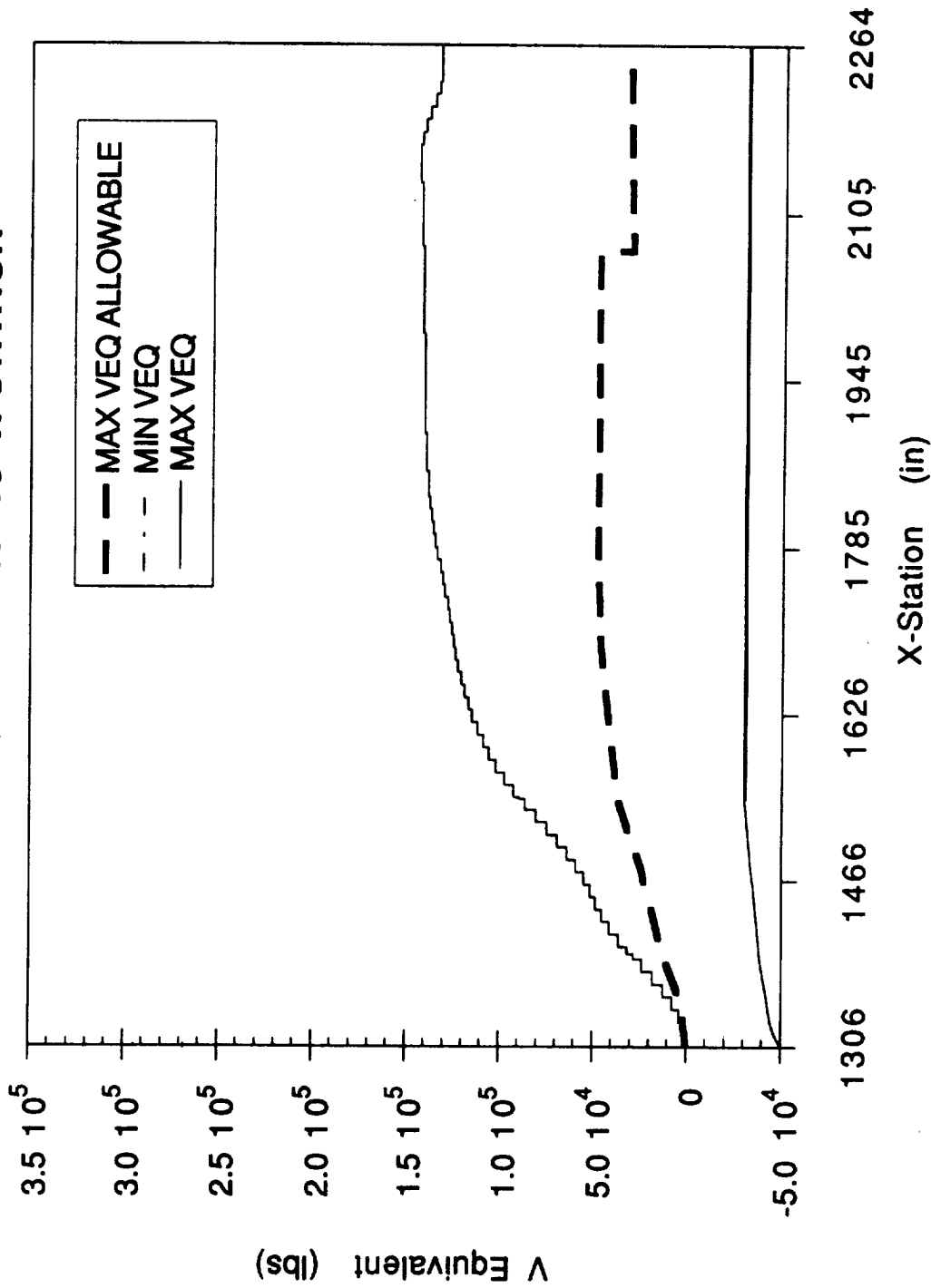

**NLS2 CORE - 10 km ENGINE OUT
NX vs X-STATION**

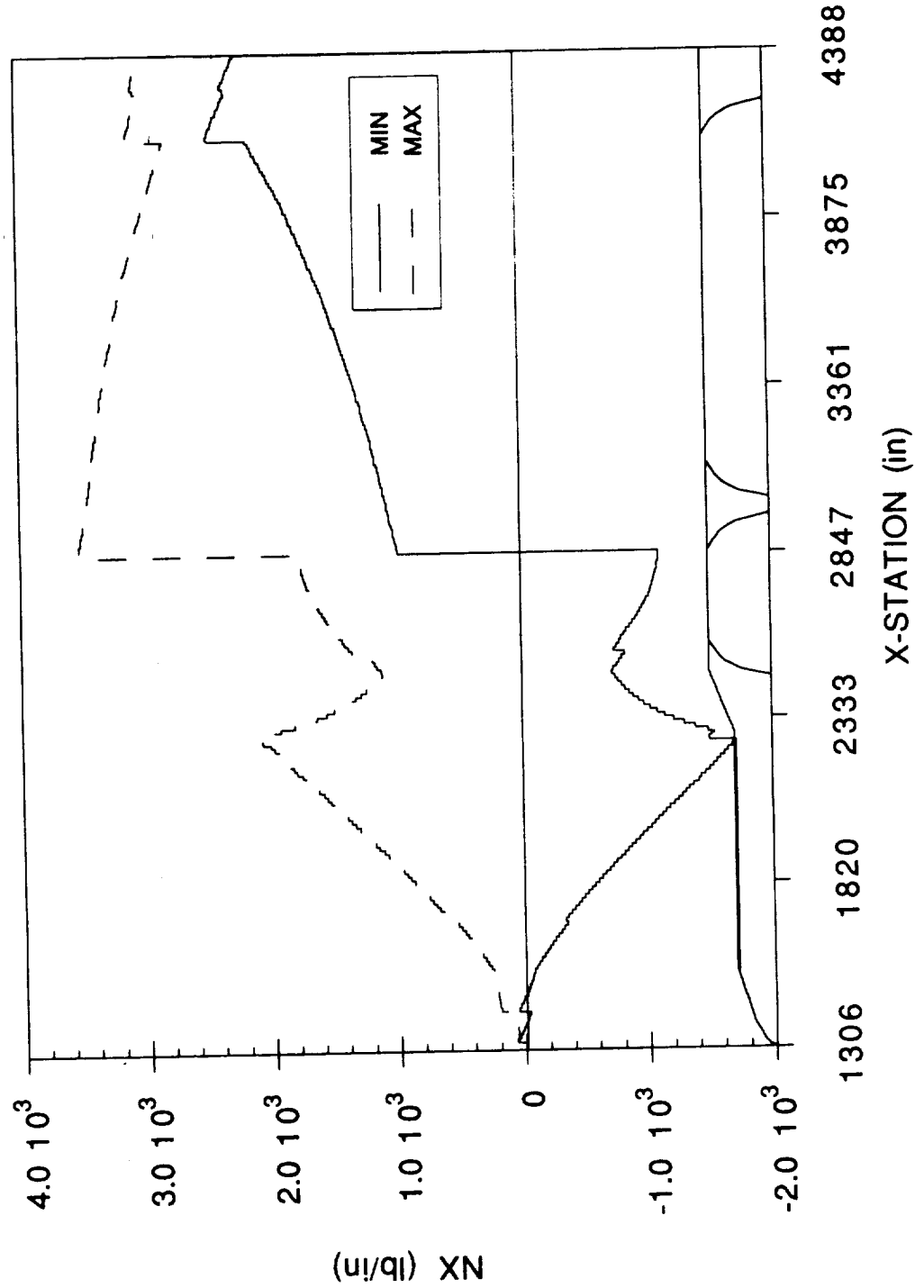

NLS2 CORE - 10 km ENGINE OUT NV vs X-STATION

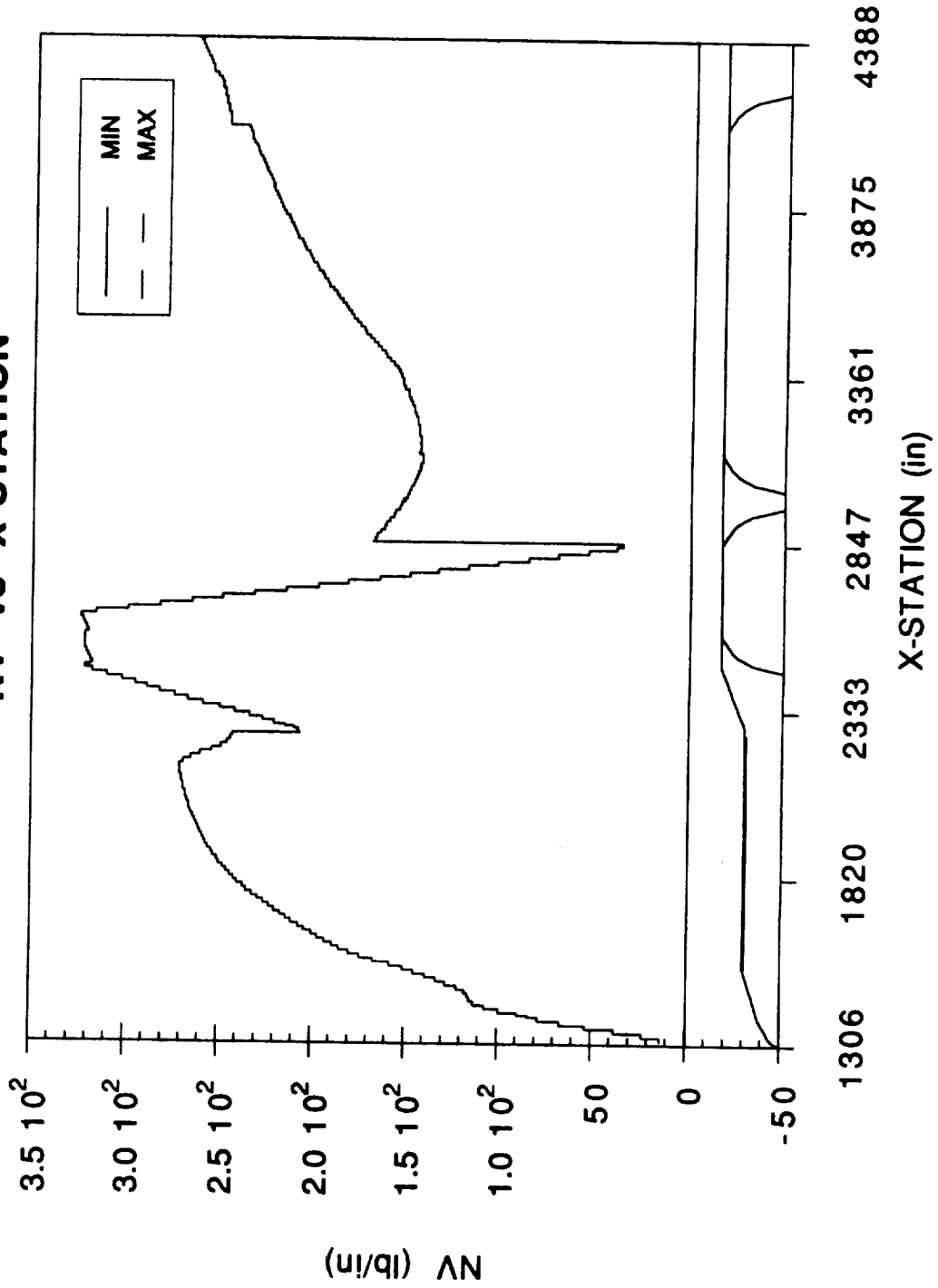

((

**NLS2 CORE - 10 km ENGINE OUT
AXIAL SHEAR VS X-STATION**

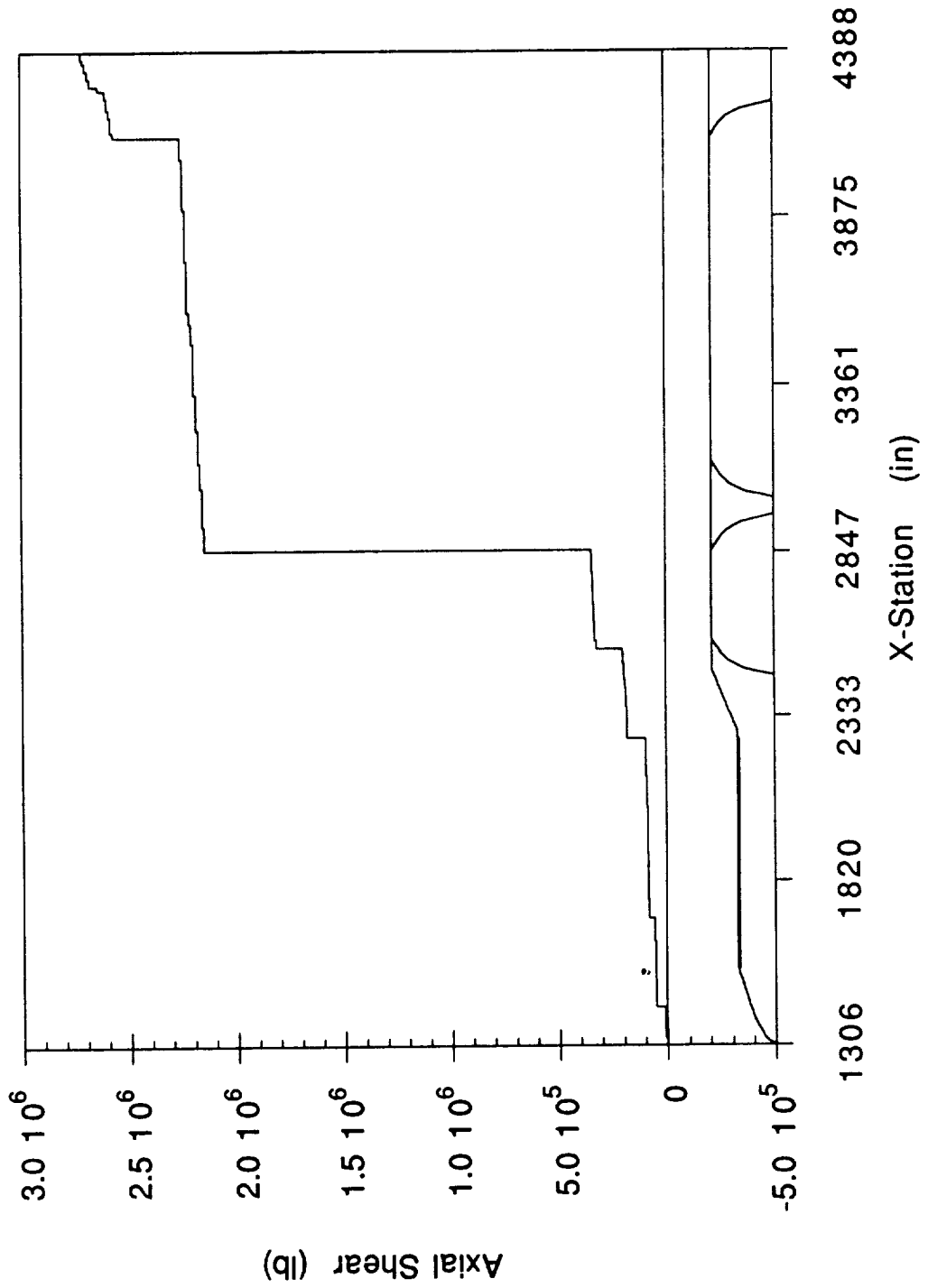

**NLS2 CORE - 10 km ENGINE OUT
Y-DIR SHEAR vs X-STATION**

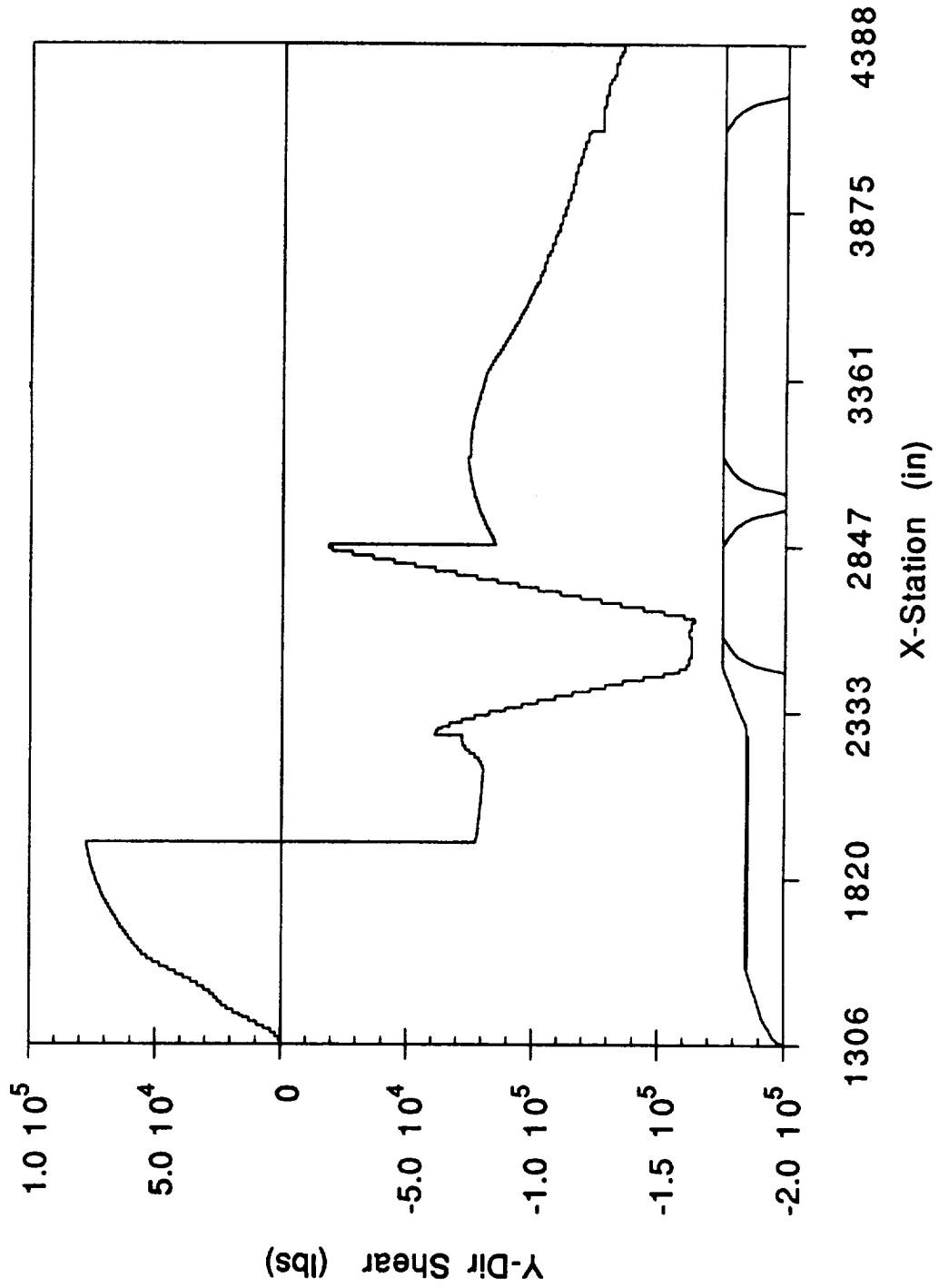

**NLS2 CORE - 10 km ENGINE OUT
Z-DIR SHEAR vs X-STATION**

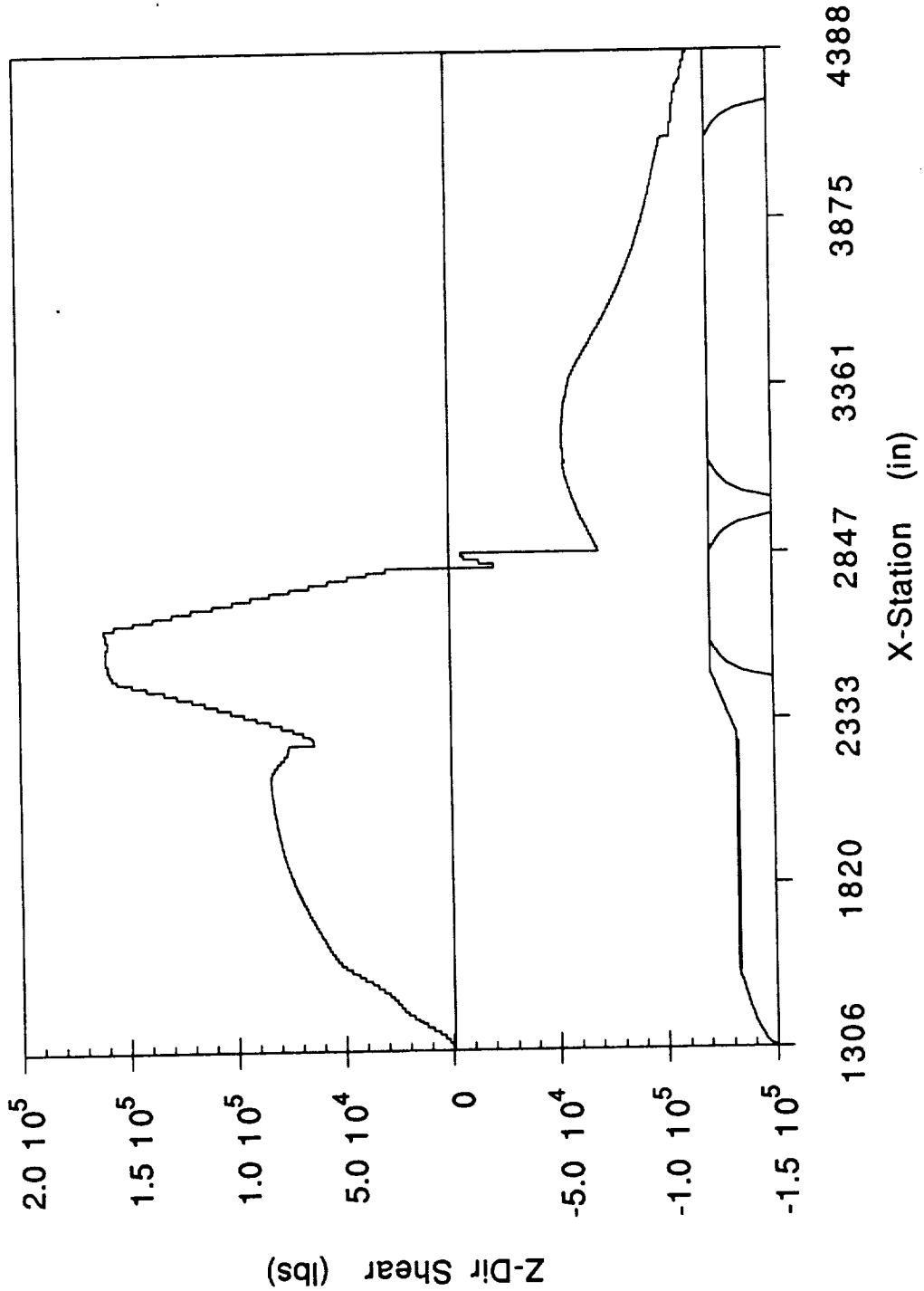

NLS2 CORE - 10 km ENGINE OUT Y-DIR MOMENT vs X-STATION

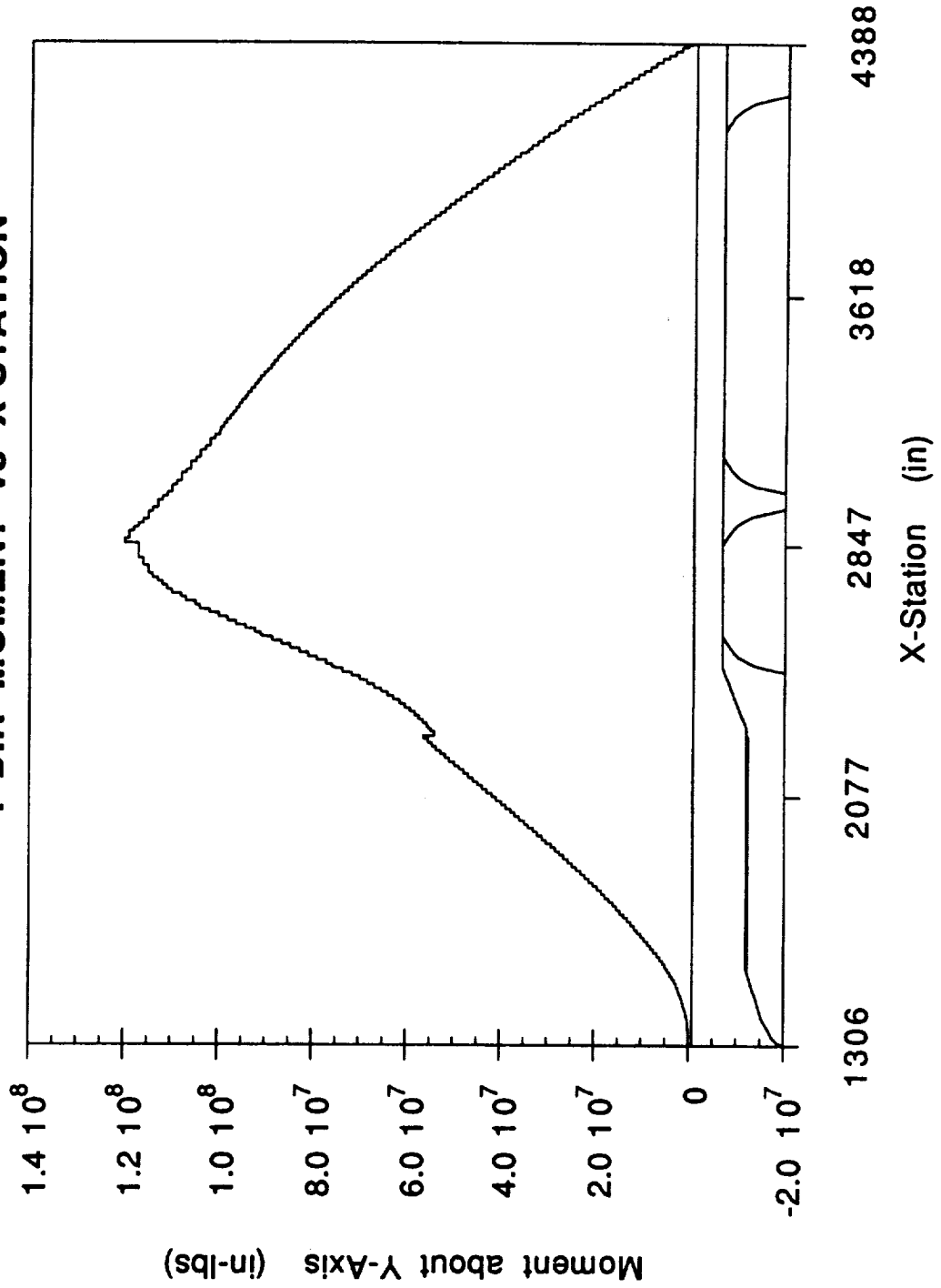

(

(

(

**NLS2 CORE - 10 km ENGINE OUT
Z-DIR MOMENT vs X-STATION**

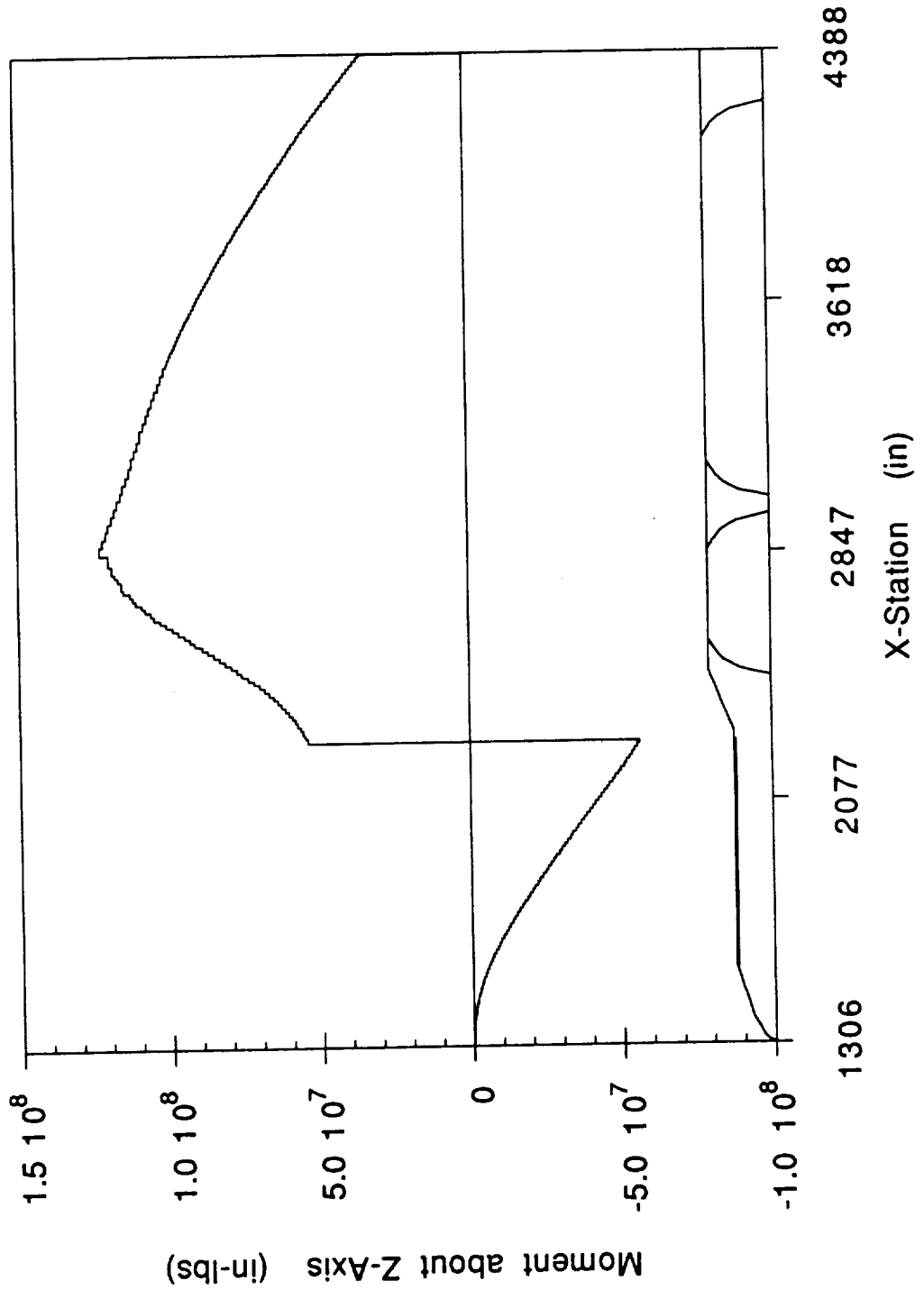

NLS2 CORE 10 km ENGINE OUT P EQUIVALENT vs X-STATION

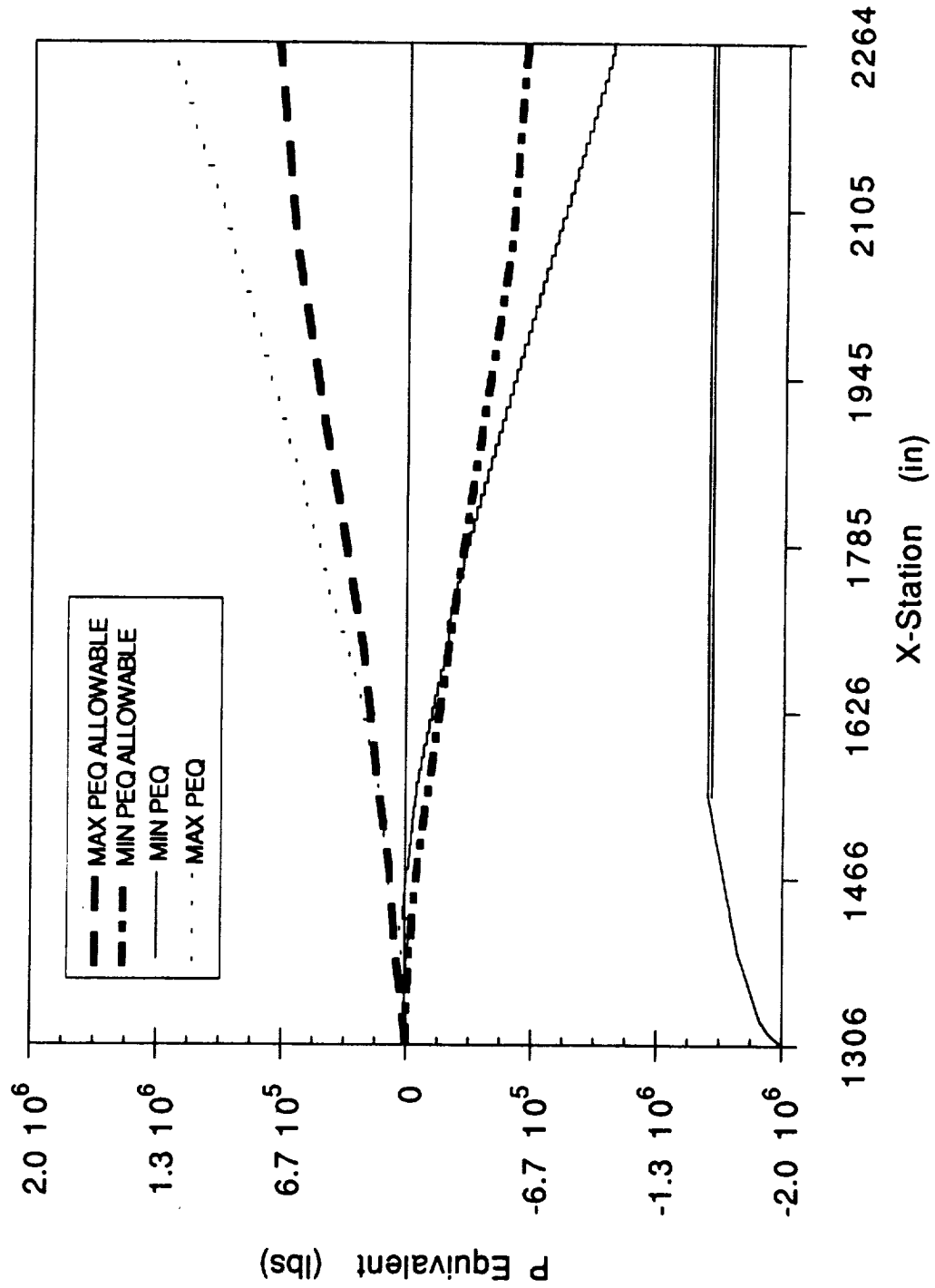

**NLS2 CORE 10 km ENGINE OUT
V EQUIVALENT vs X-STATION**

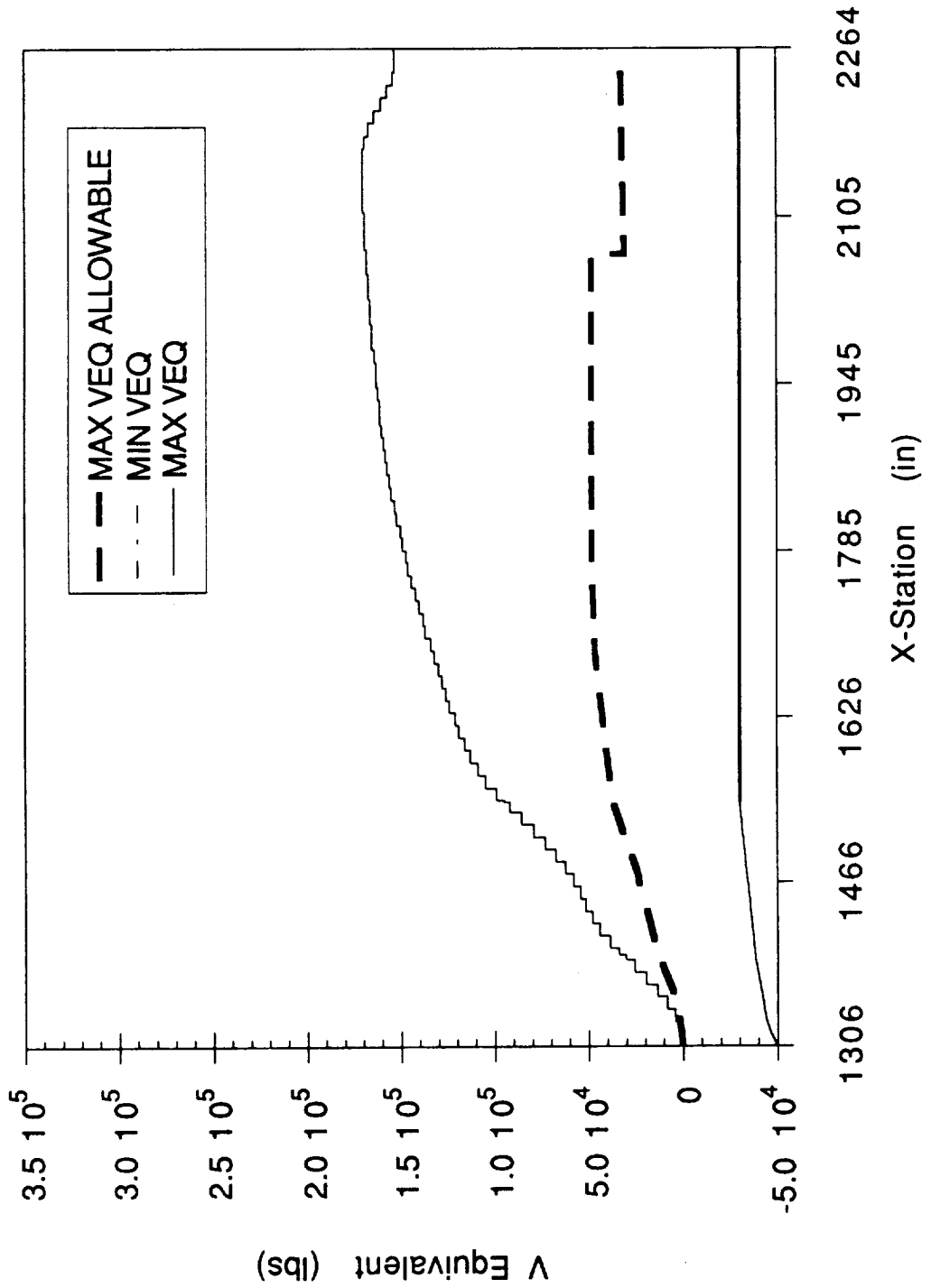

**NLS2 CORE - 12 km ENGINE OUT
NX vs X-STATION**

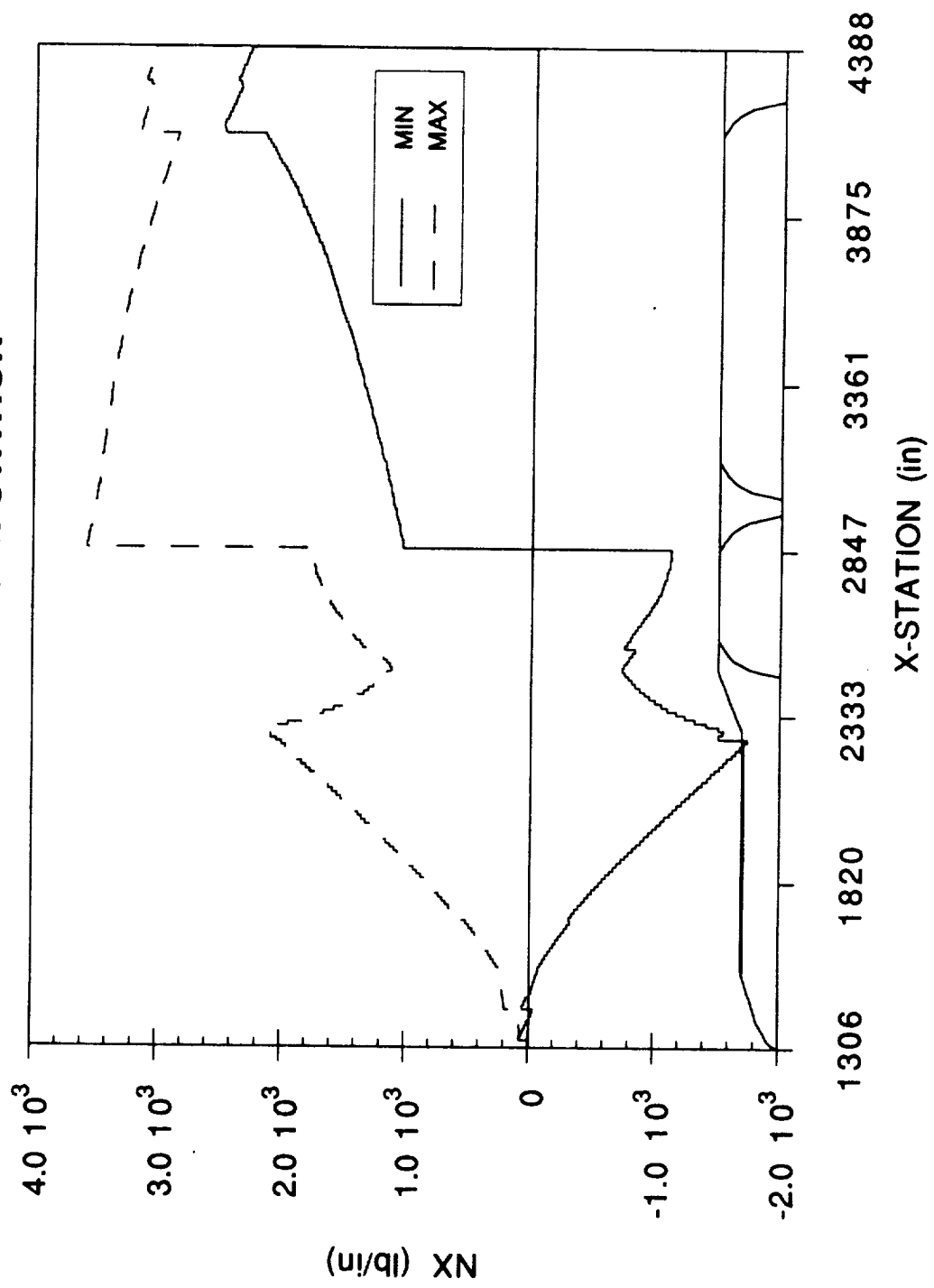

**NLS2 CORE - 12 km ENGINE OUT
NV vs X-STATION**

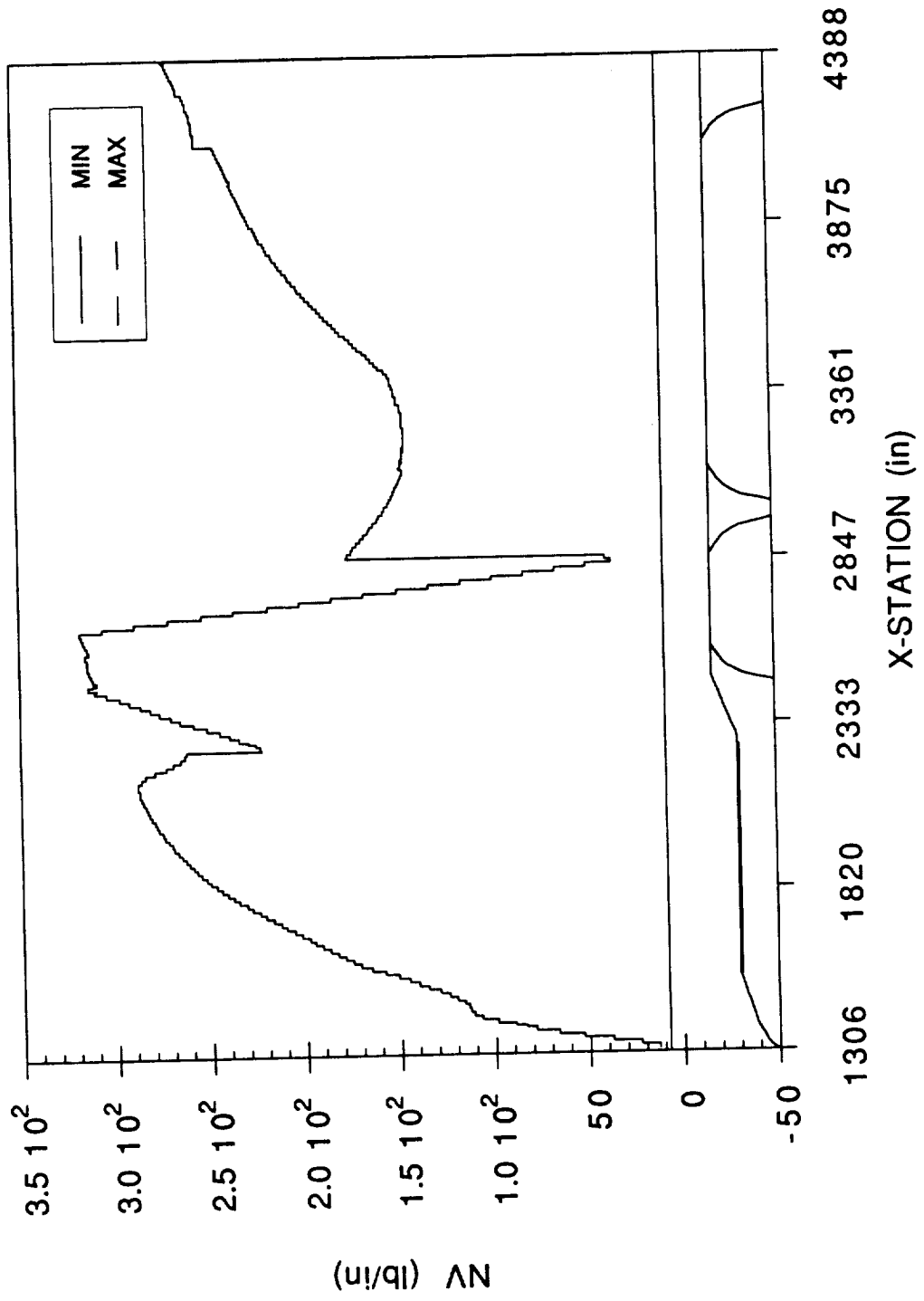

**NLS2 CORE - 12 km ENGINE OUT
AXIAL SHEAR vs X-STATION**

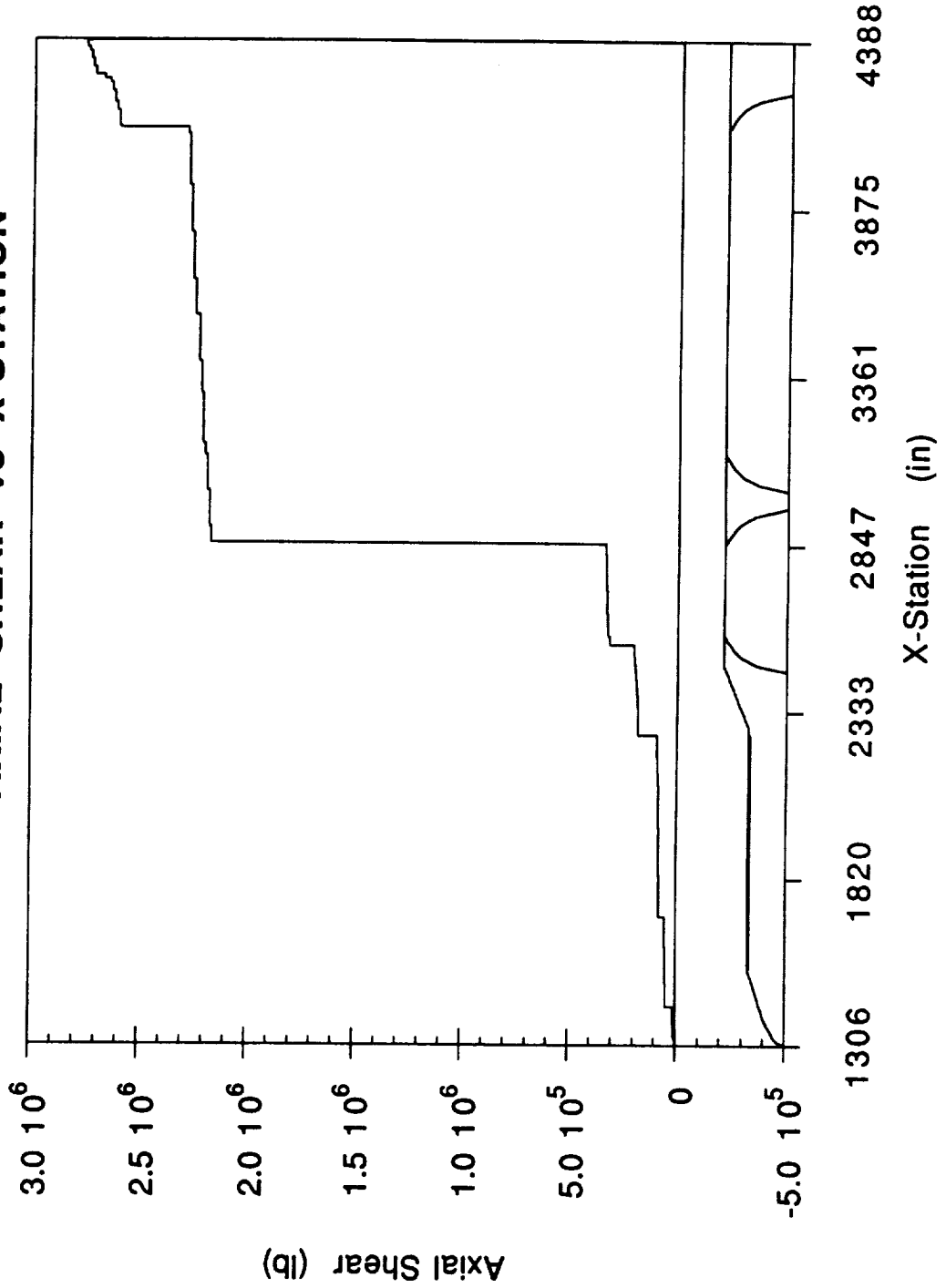

**NLS2 CORE - 12 km ENGINE OUT
Y-DIR SHEAR vs X-STATION**

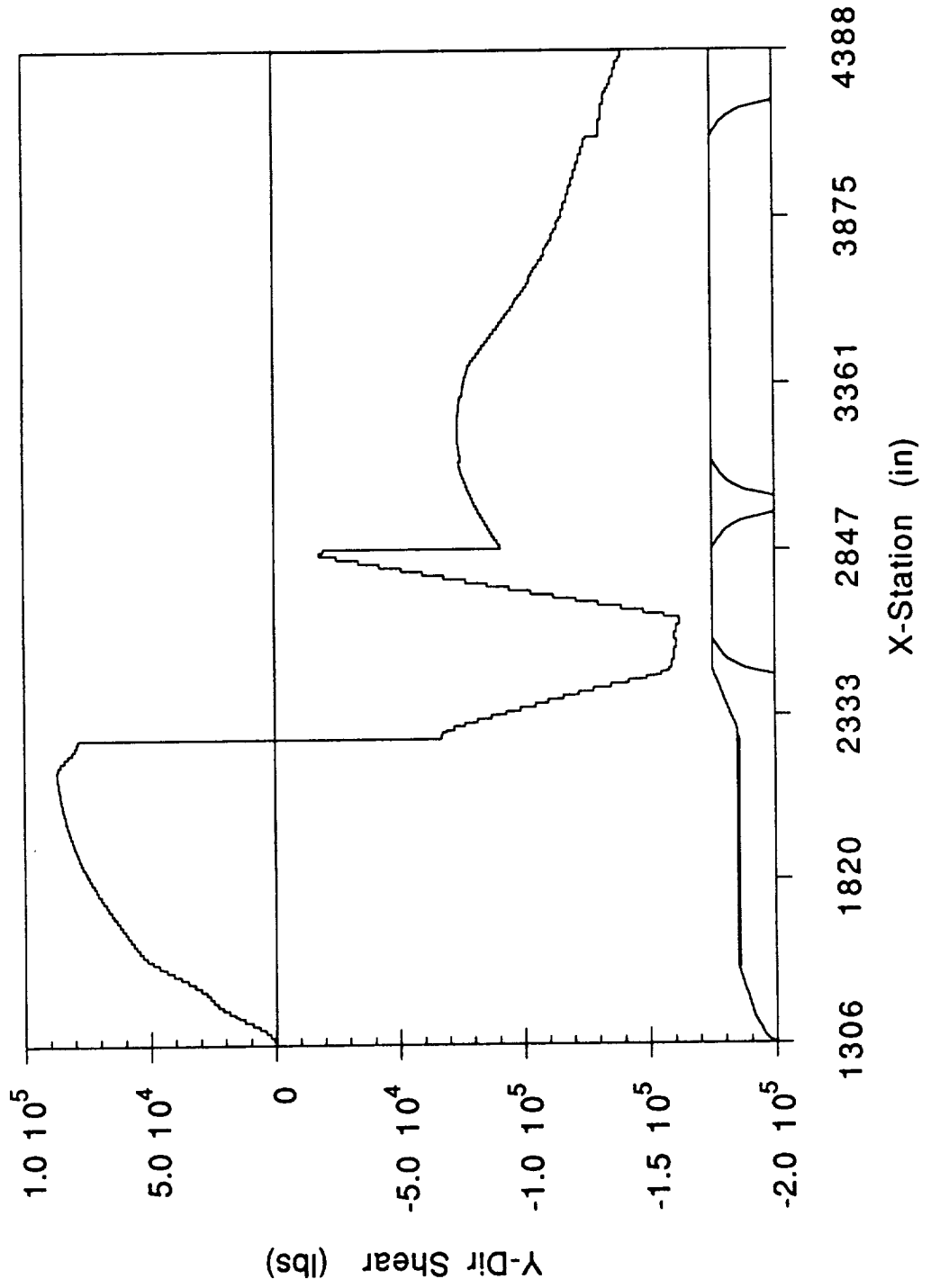

NLS2 CORE - 12 km ENGINE OUT
Z-DIR SHEAR vs X-STATION

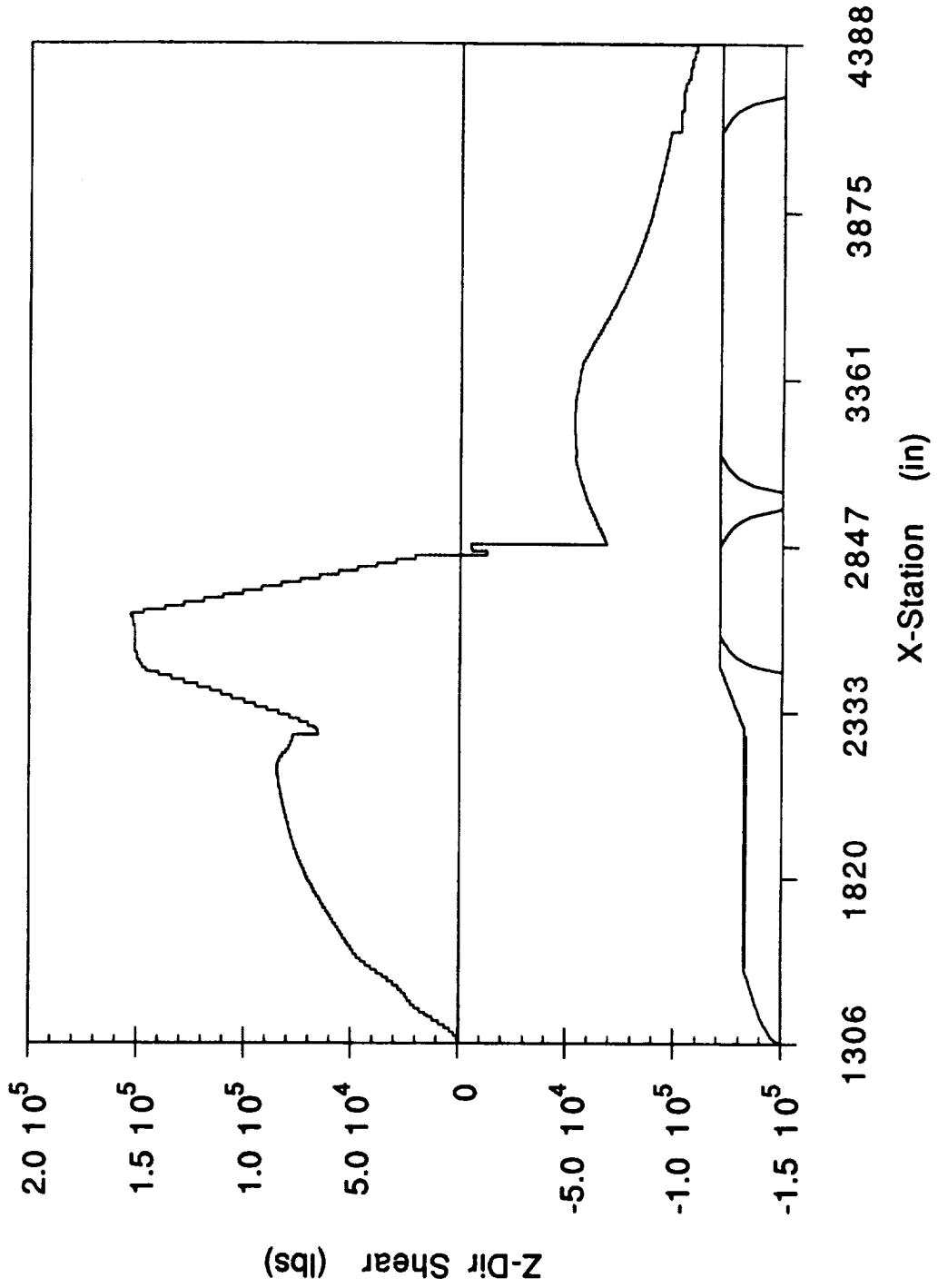

((

NLS2 CORE - 12 km ENGINE OUT Y-DIR MOMENT vs X-STATION

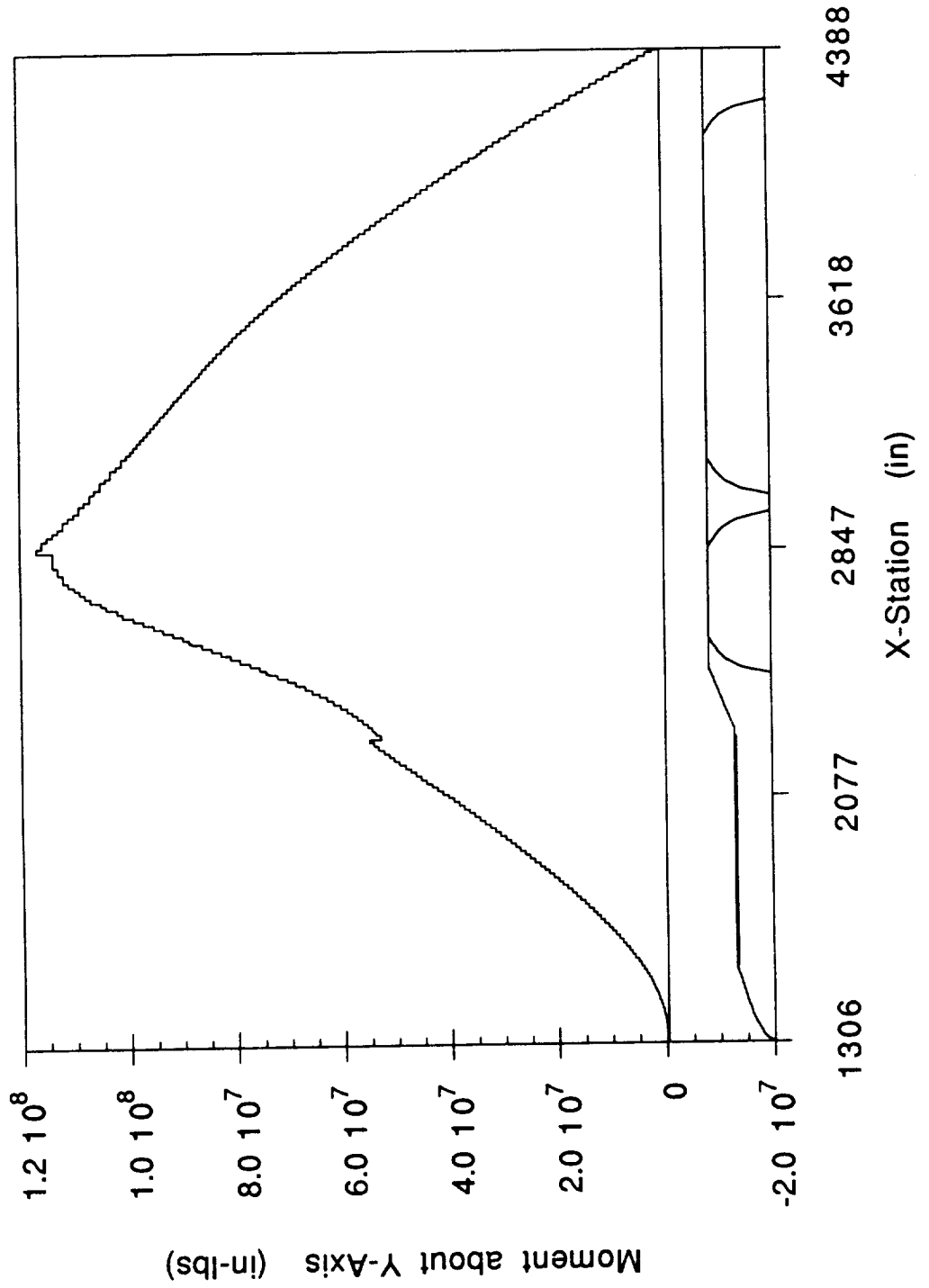

**NLS2 CORE - 12 km ENGINE OUT
Z-DIR MOMENT vs X-STATION**

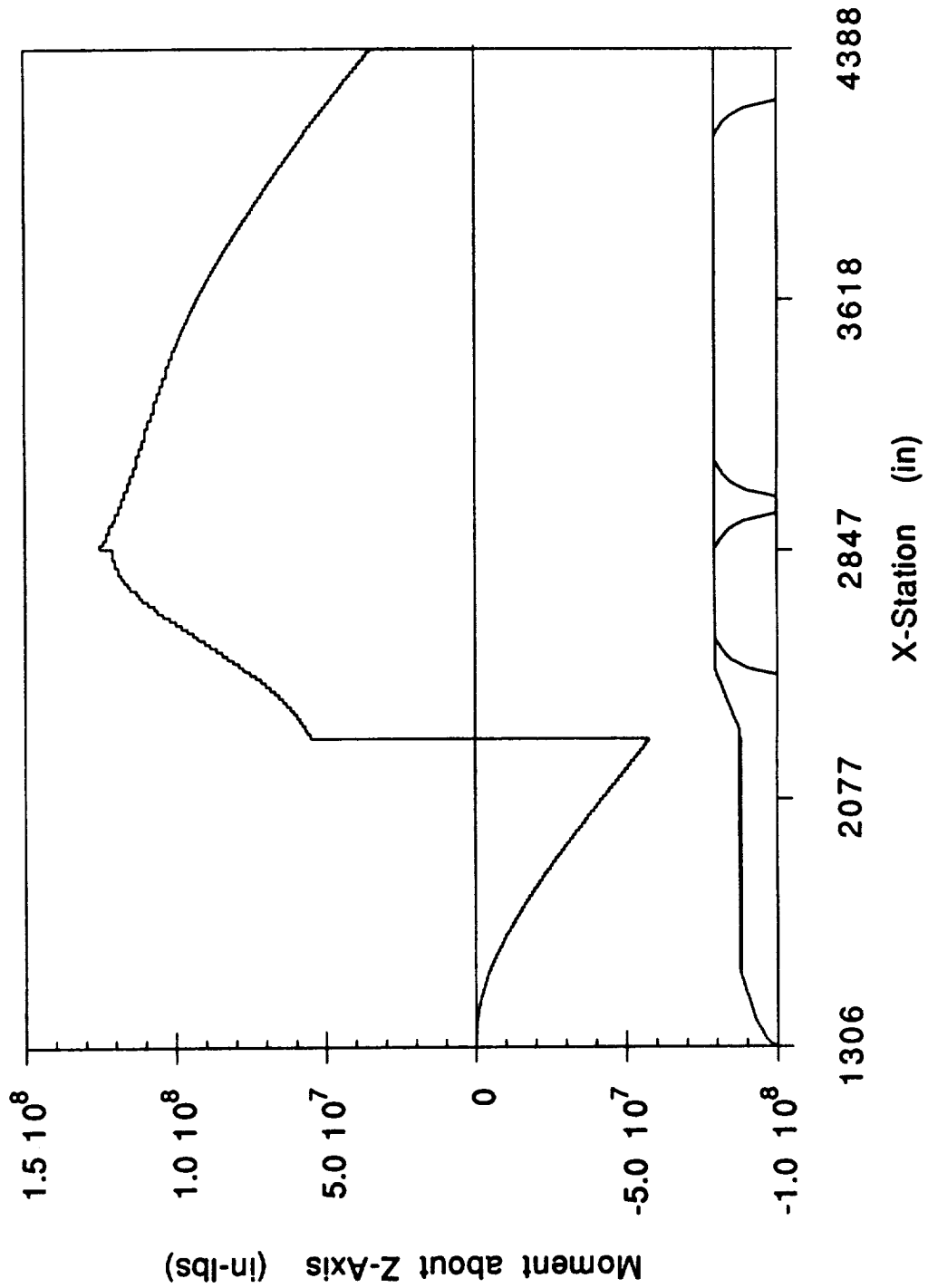

NLS2 CORE 12 km ENGINE OUT P EQUIVALENT vs X-STATION

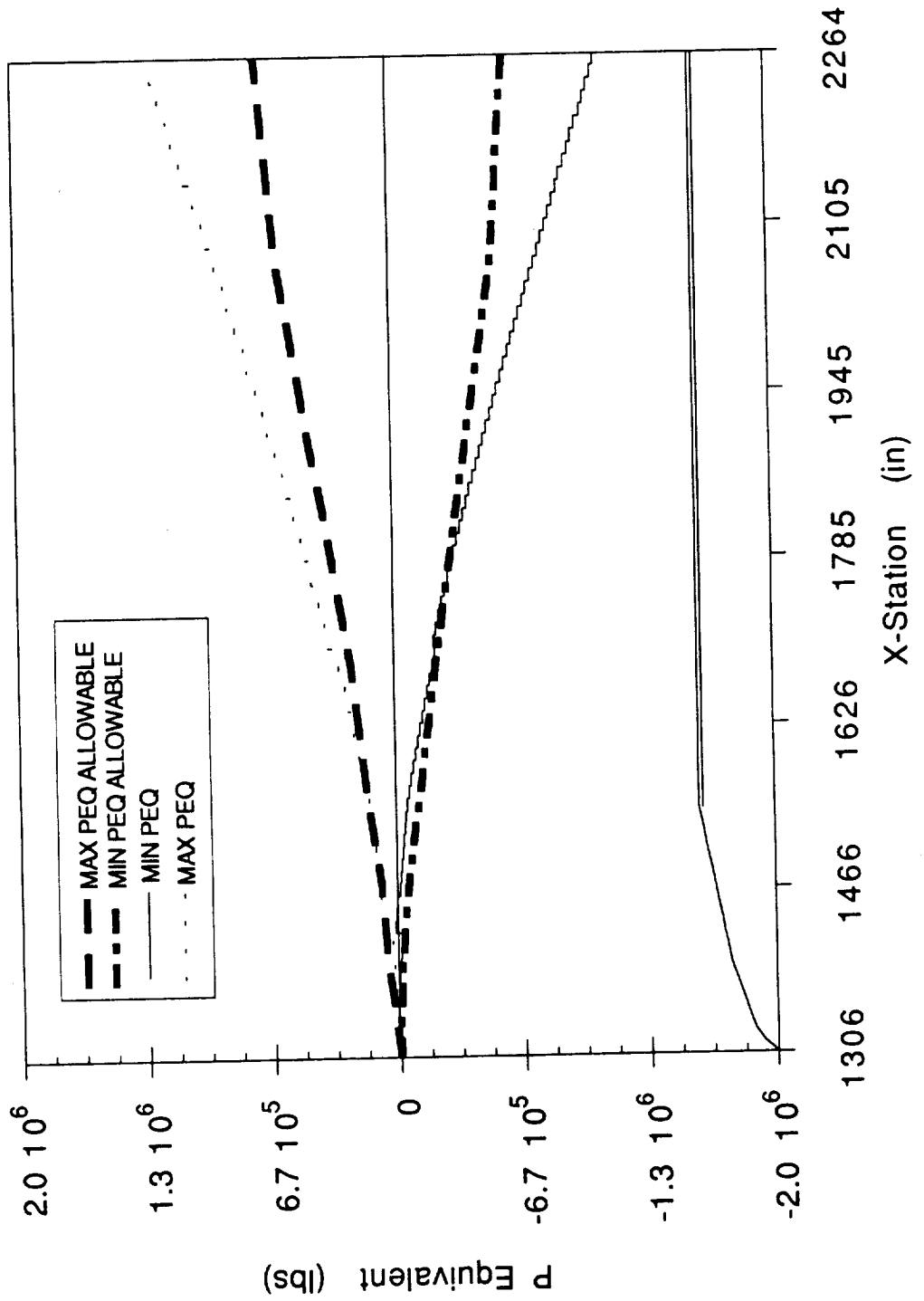

NLS2 CORE 12 km ENGINE OUT V EQUIVALENT vs X-STATION

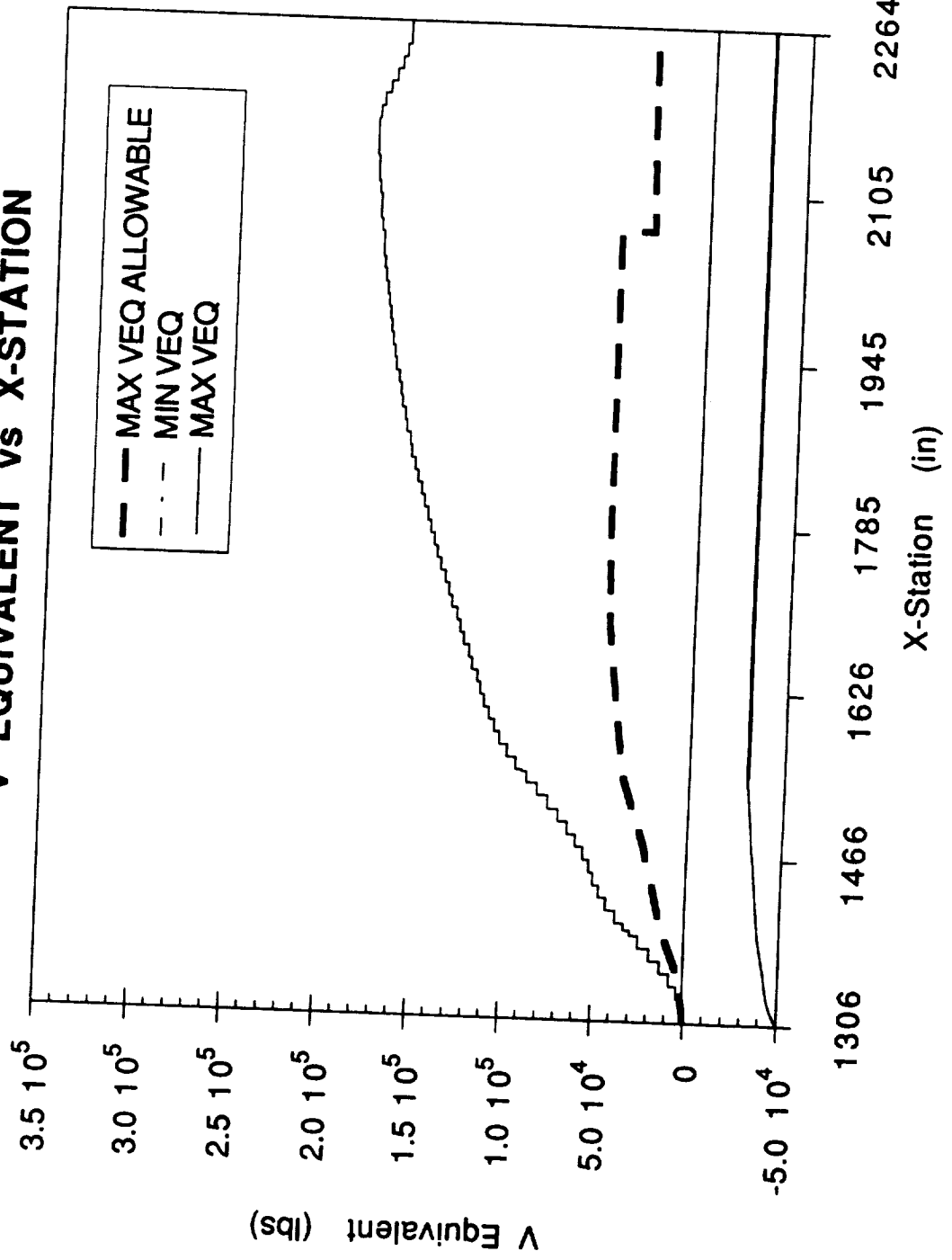

**NLS2 CORE - 13km ENGINE OUT
NX vs X-STATION**

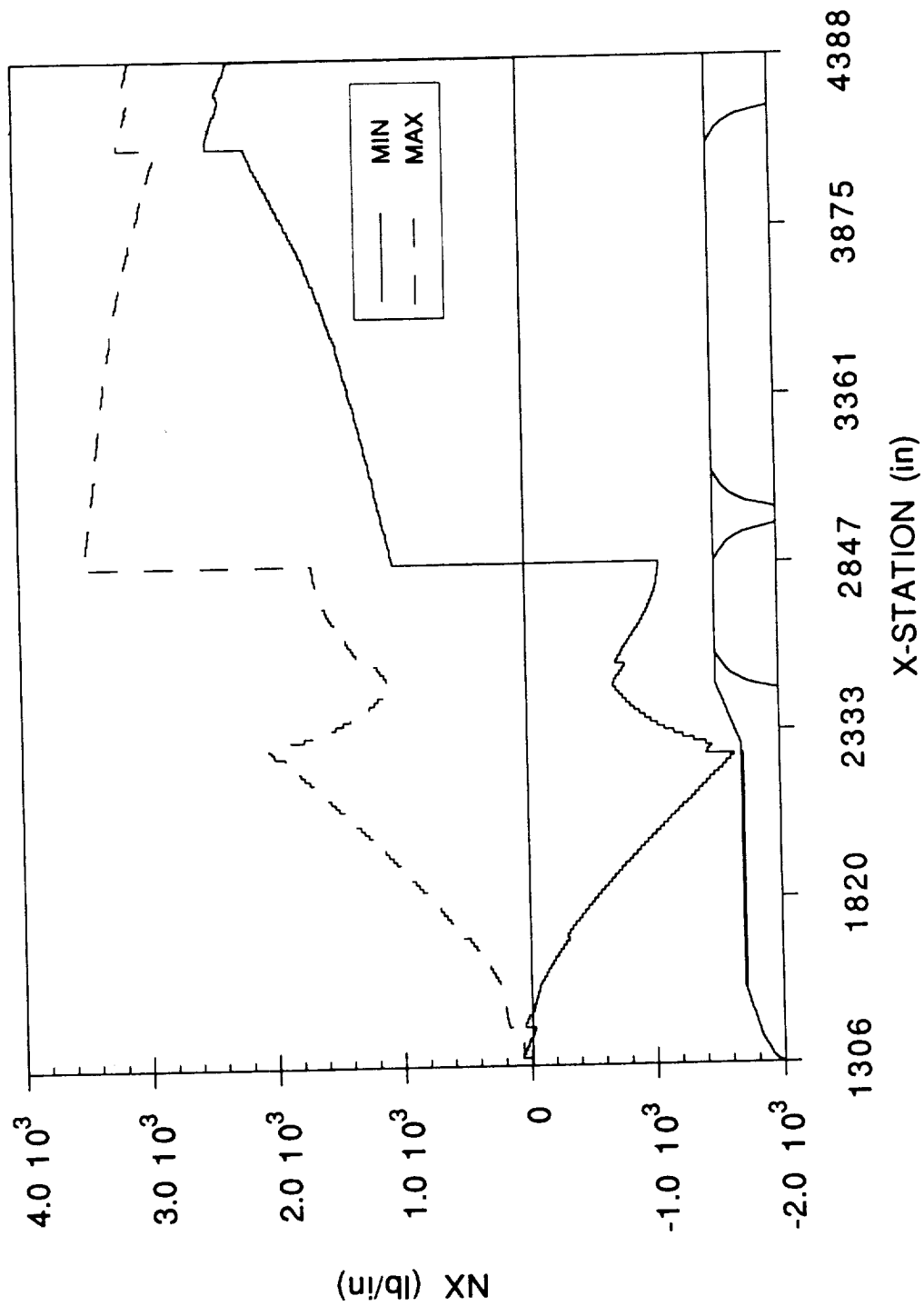

**NLS2 CORE - 13 km ENGINE OUT
NV vs X-STATION**

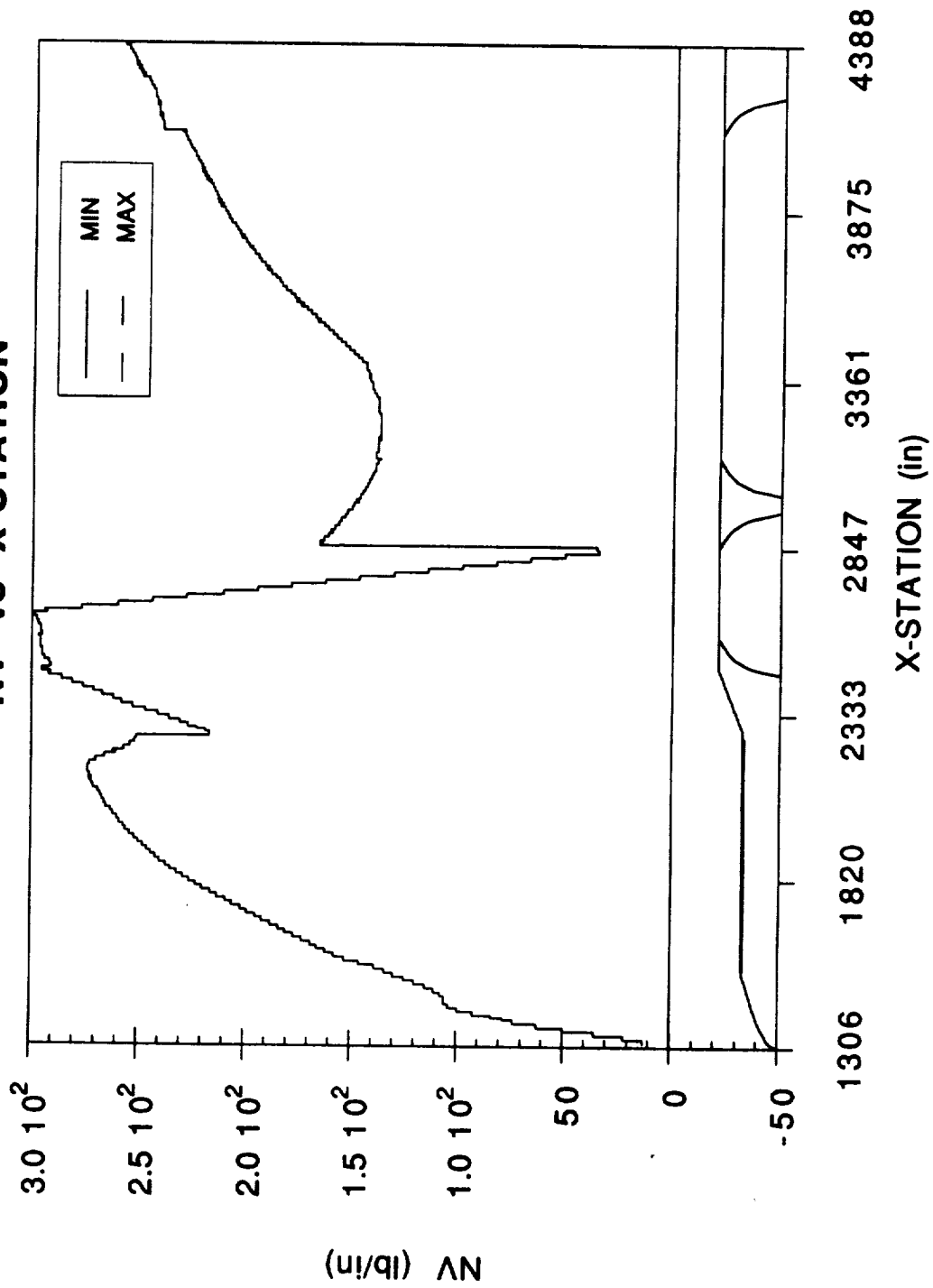

**NLS2 CORE - 13 km ENGINE OUT
AXIAL SHEAR vs X-STATION**

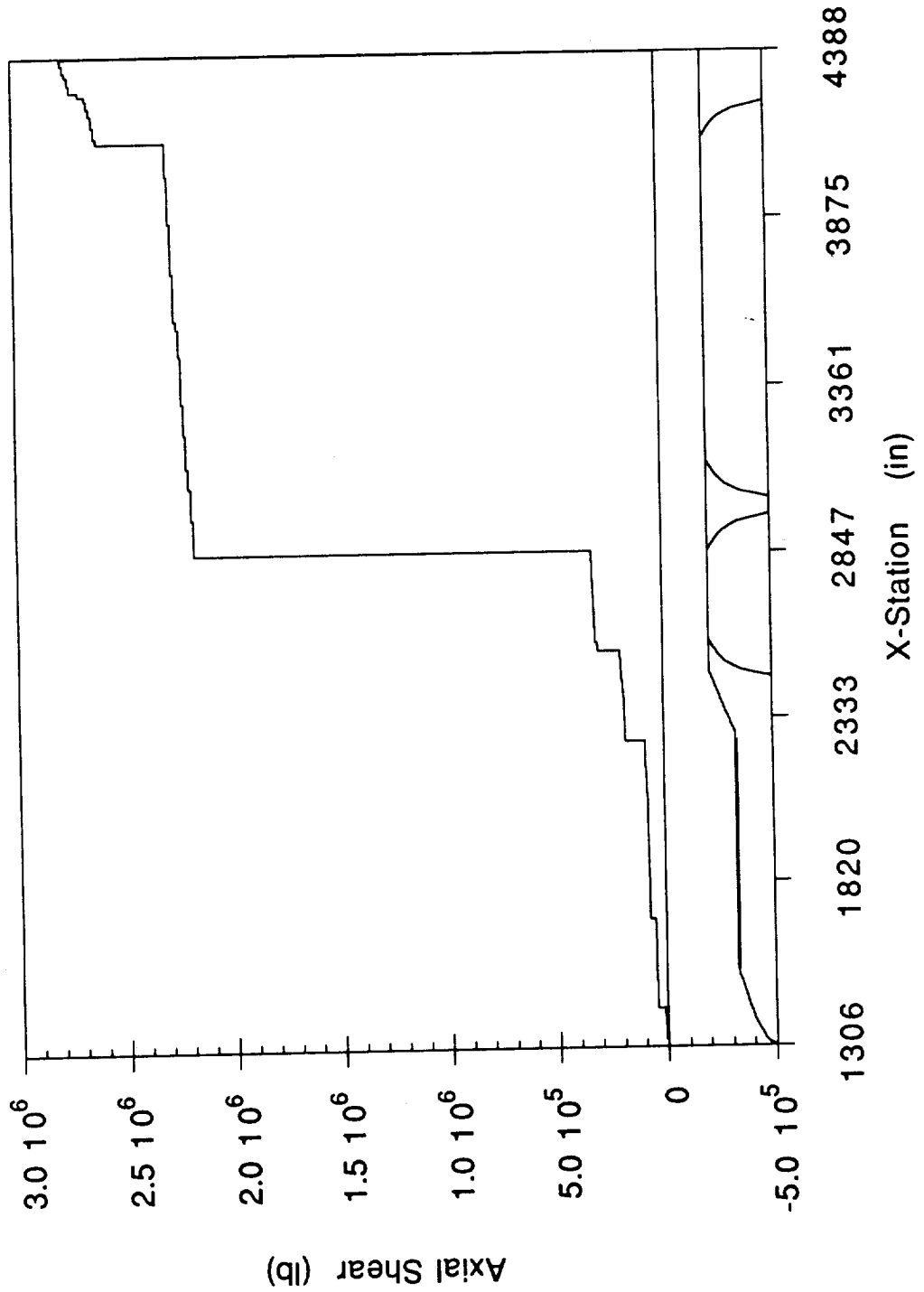

**NLS2 CORE - 13 km ENGINE OUT
Y-DIR SHEAR vs X-STATION**

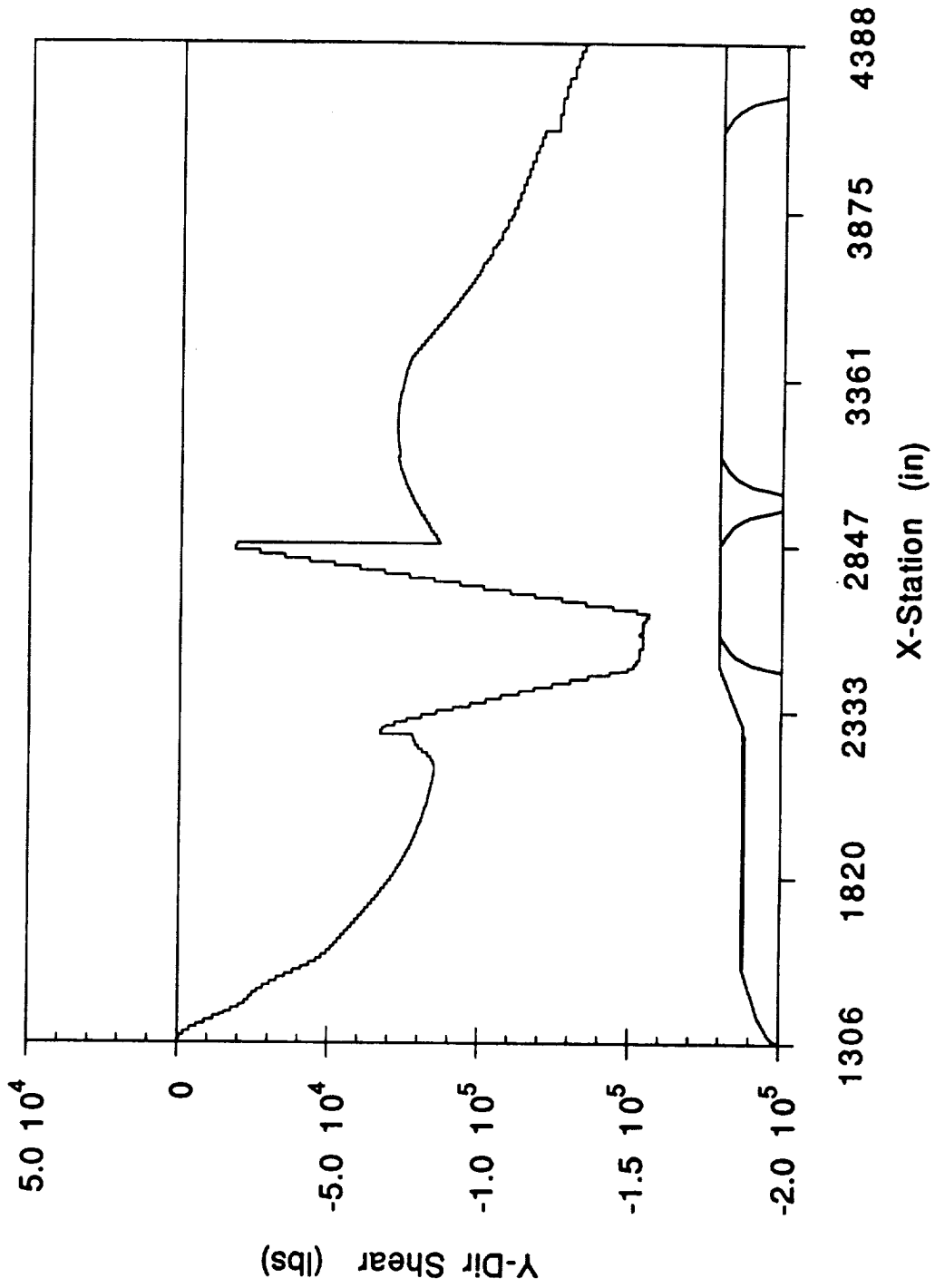

**NLS2 CORE - 13 km ENGINE OUT
Z-DIR SHEAR vs X-STATION**

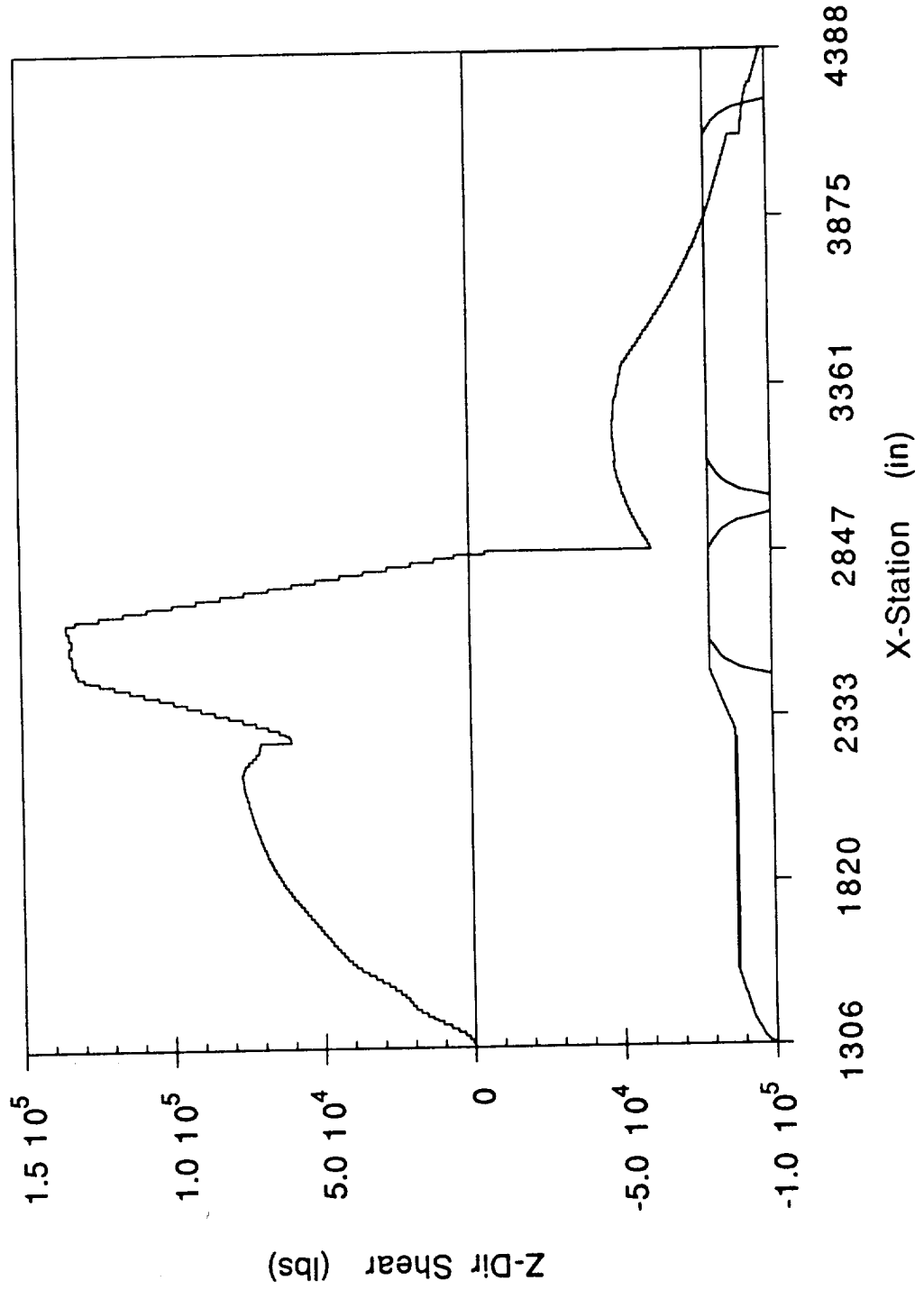

**NLS2 CORE - 13 km ENGINE OUT
Y-DIR MOMENT vs X-STATION**

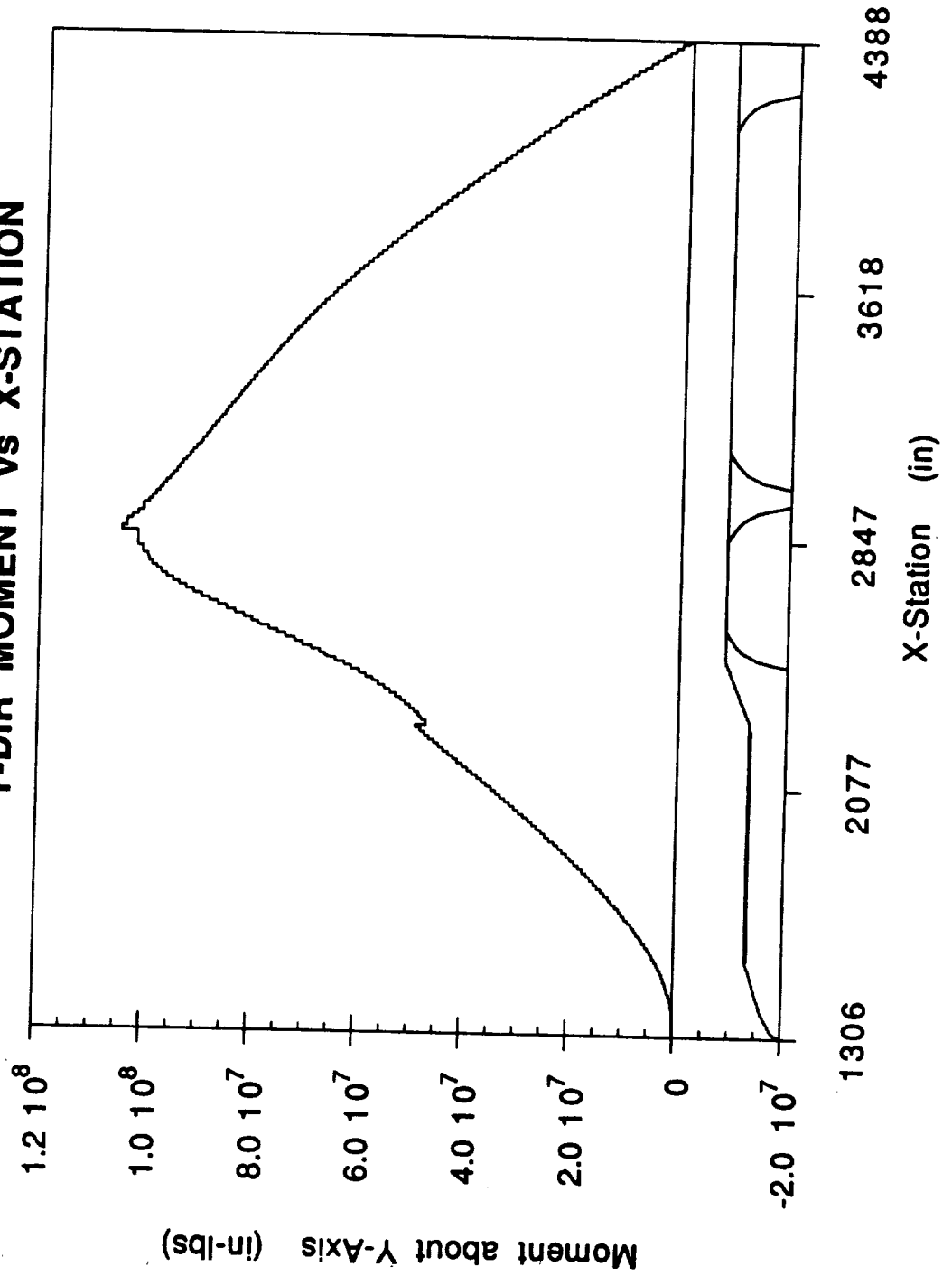

**NLS2 CORE - 13 km ENGINE OUT
Z-DIR MOMENT VS X-STATION**

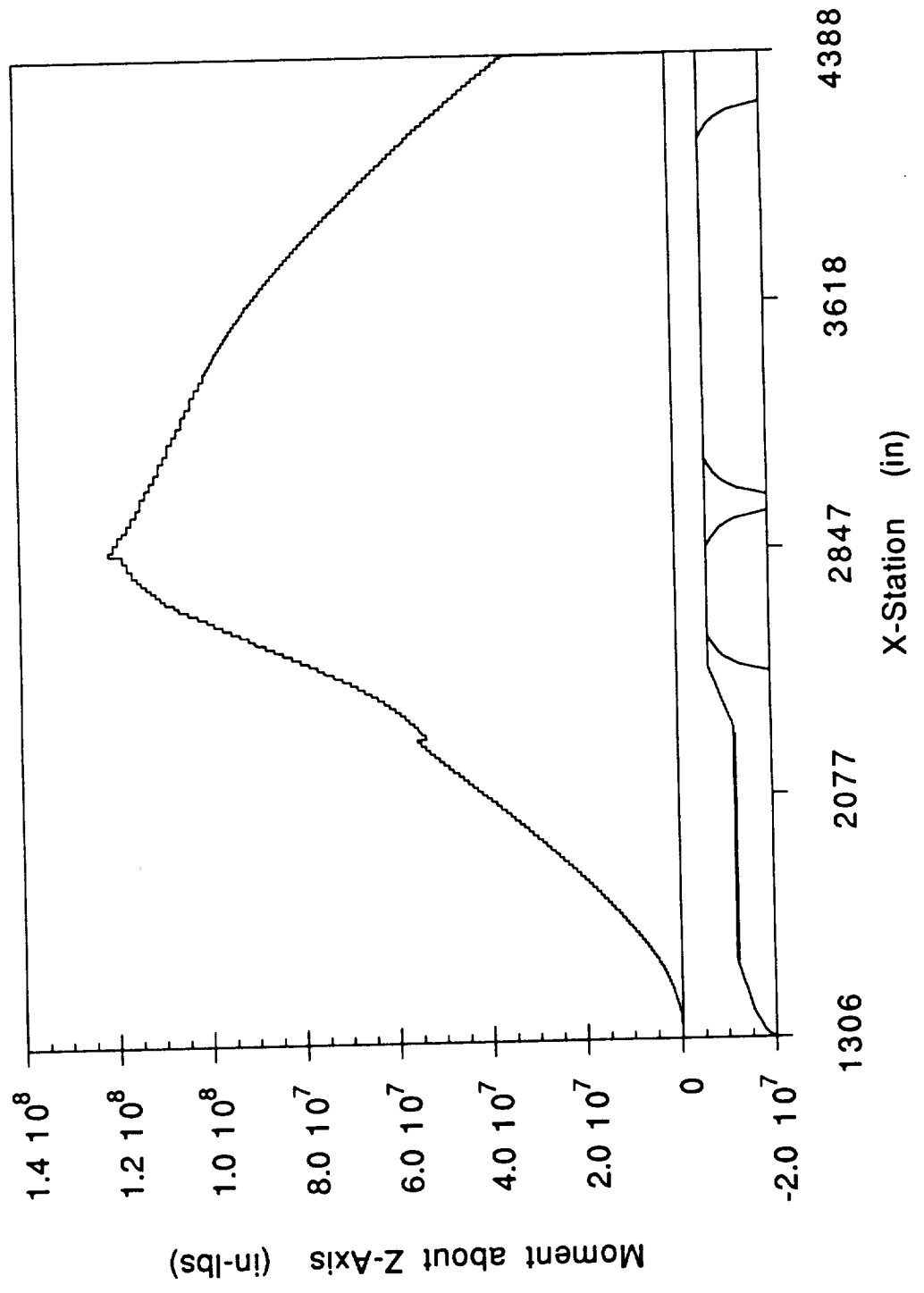

NLS2 CORE 13 km ENGINE OUT P EQUIVALENT vs X-STATION

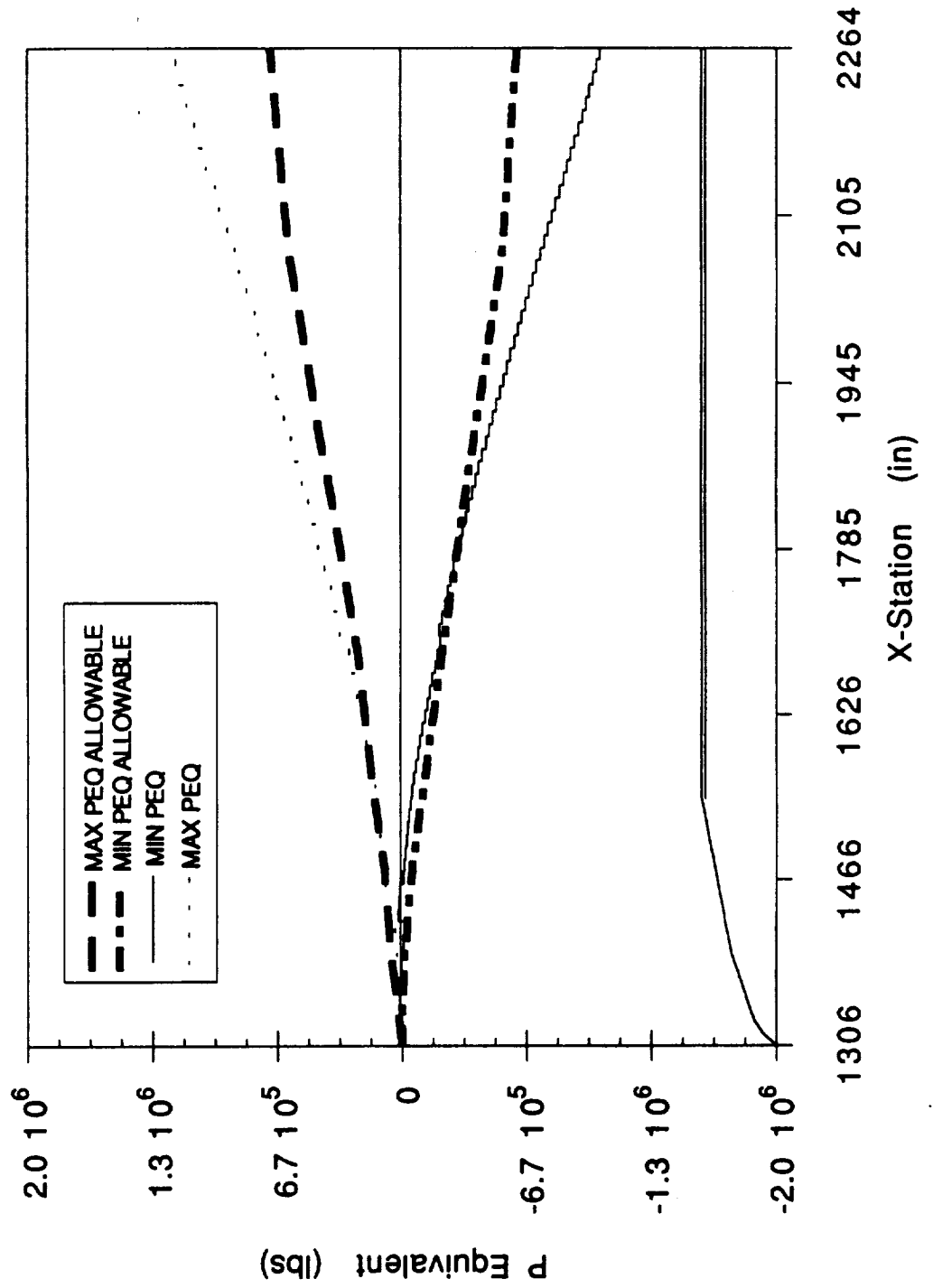

NLS2 CORE 13 km ENGINE OUT V EQUIVALENT vs X-STATION

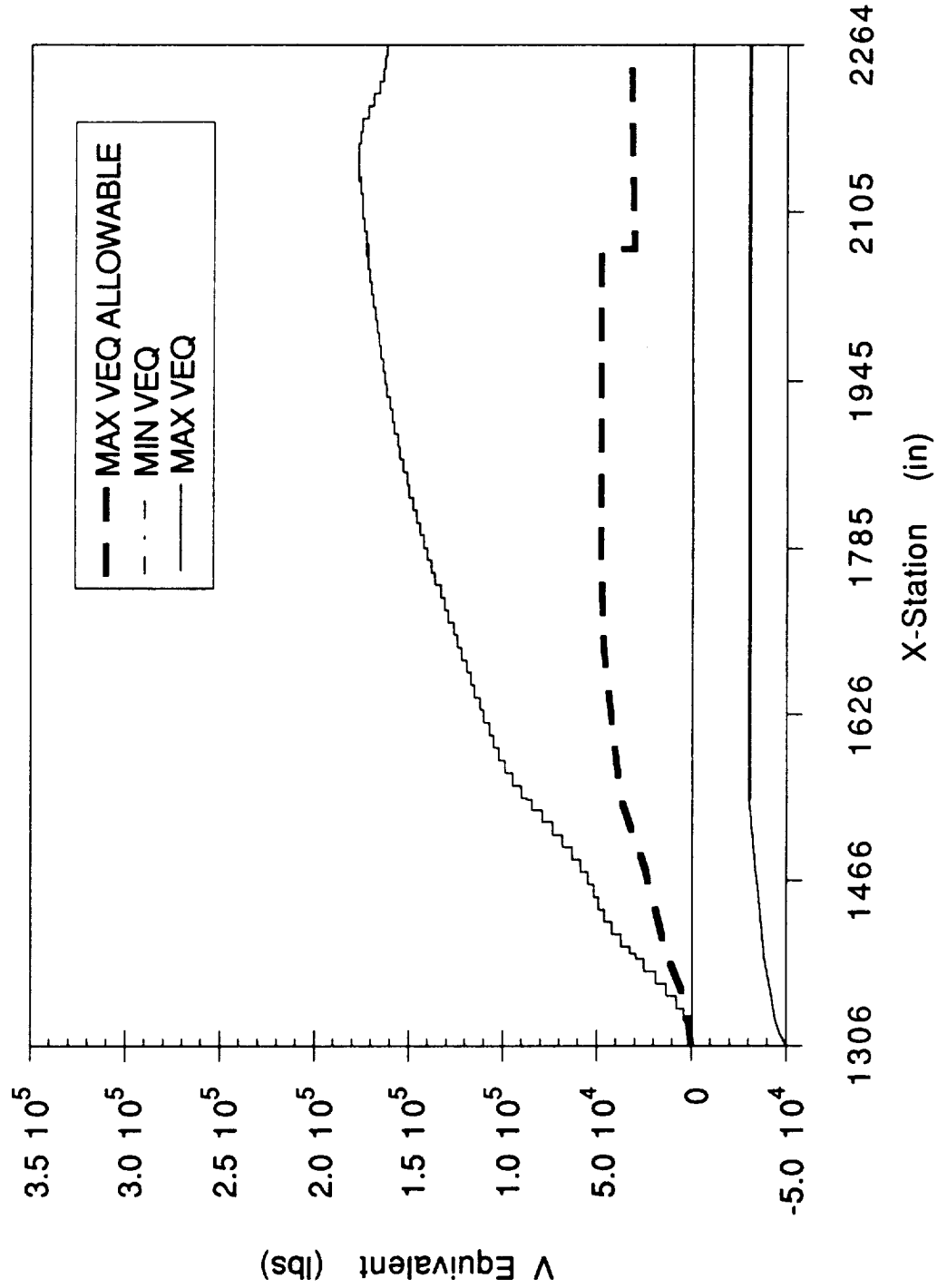

**NLS2 CORE - 14 km ENGINE OUT
NX vs X-STATION**

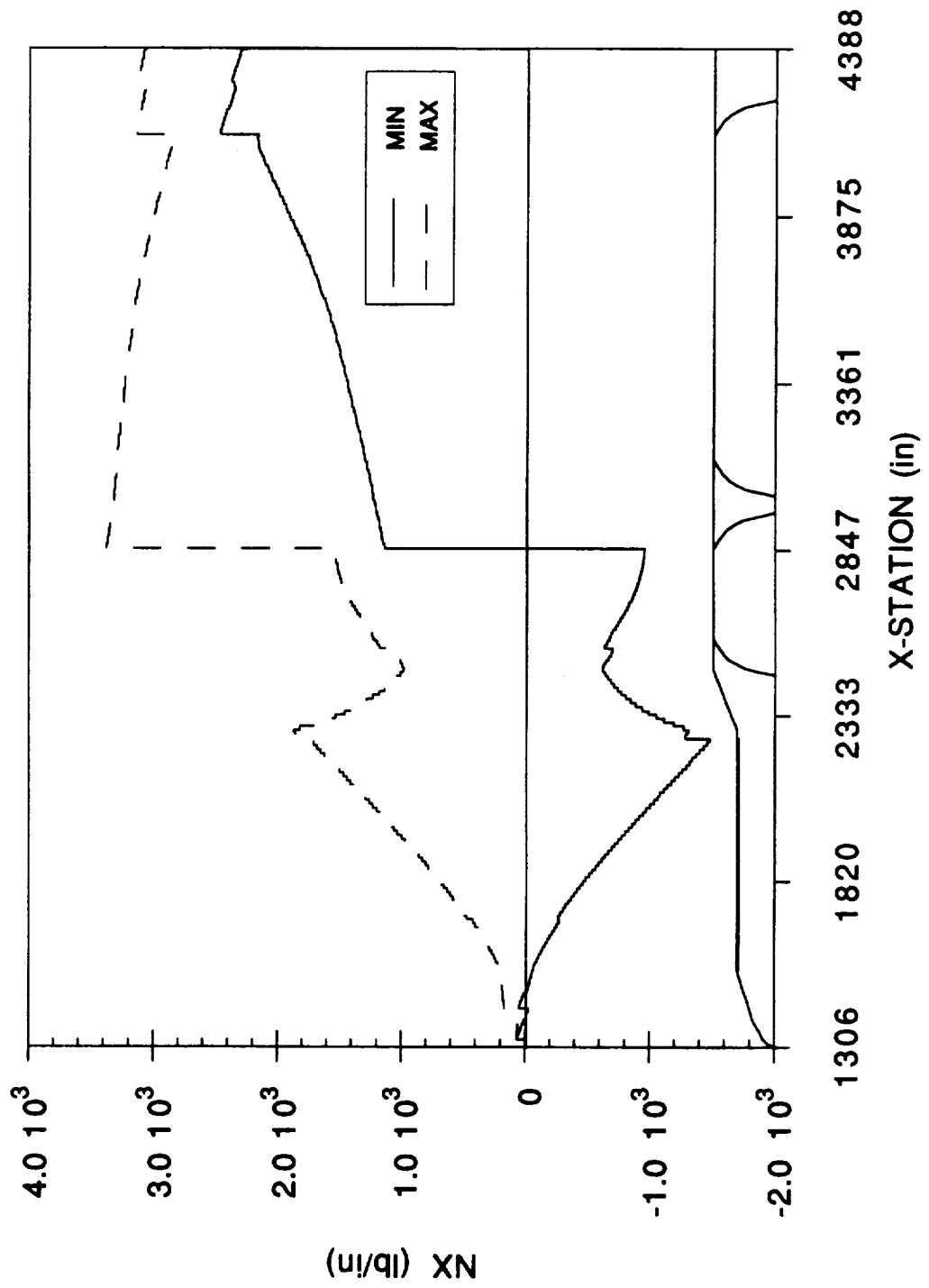

**NLS2 CORE - 14 km ENGINE OUT
NV vs X-STATION**

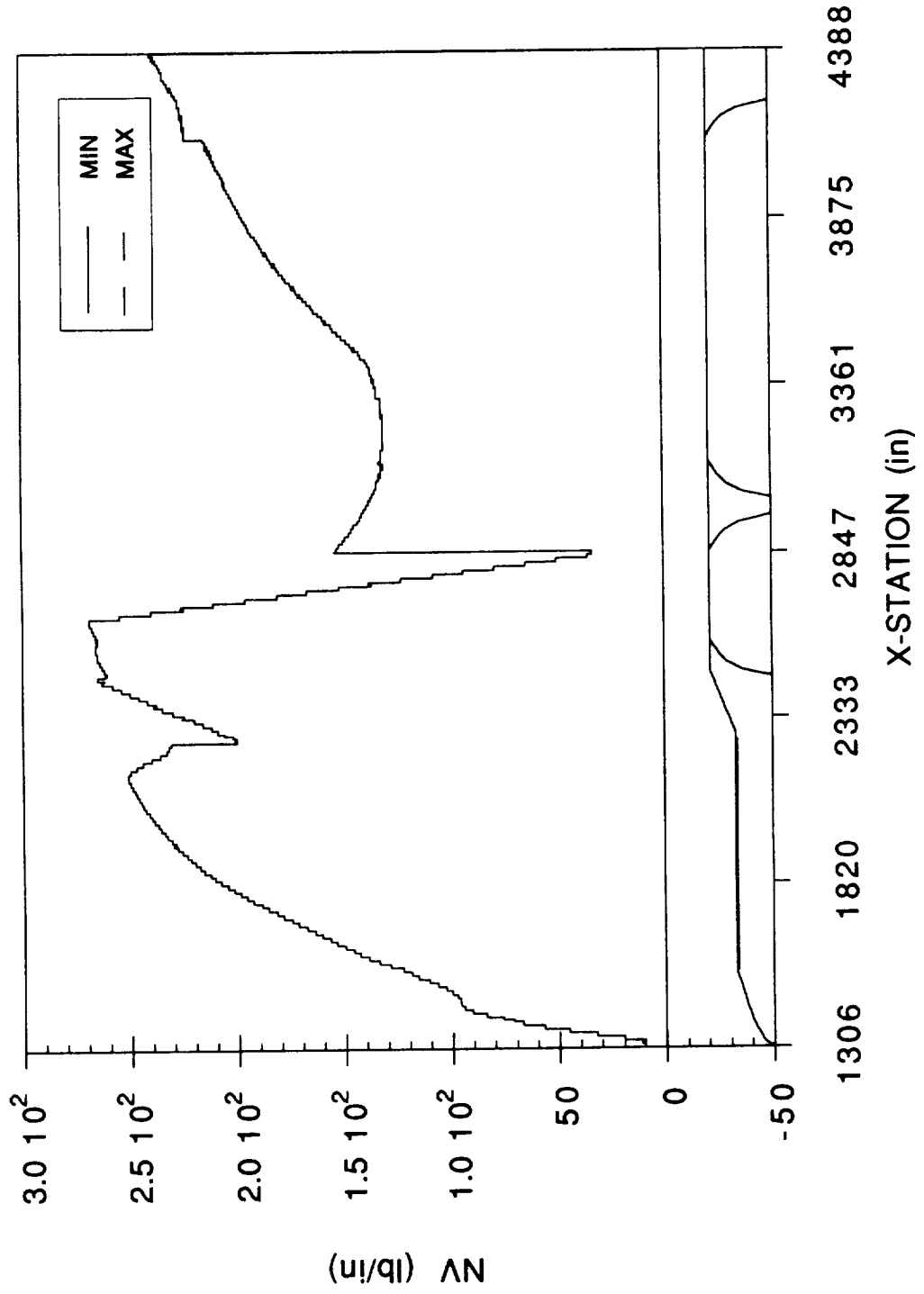

**NLS2 CORE - 14 km ENGINE OUT
AXIAL SHEAR vs X-STATION**

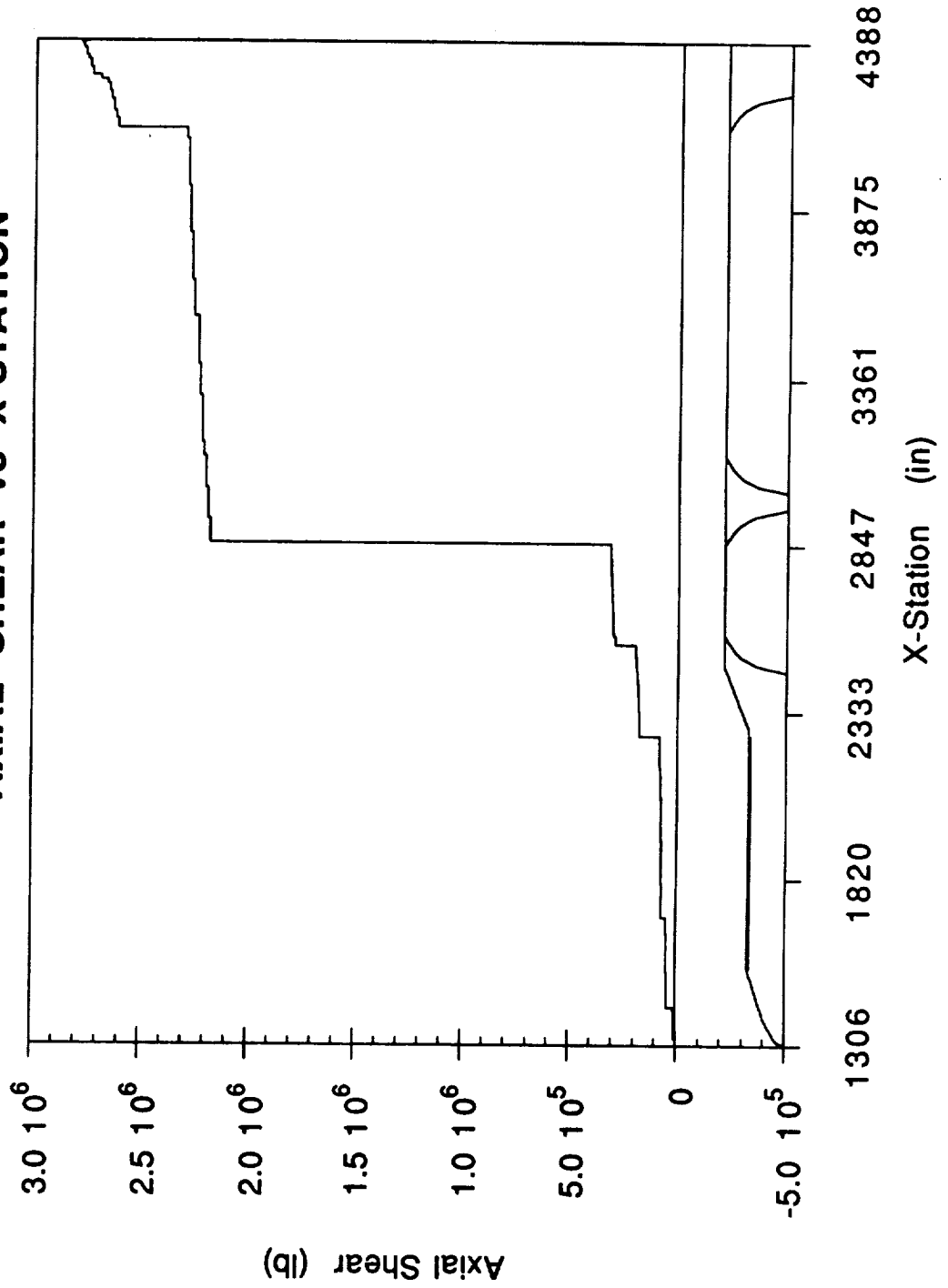

NLS2 CORE - 14 km ENGINE OUT
Y-DIR SHEAR vs X-STATION

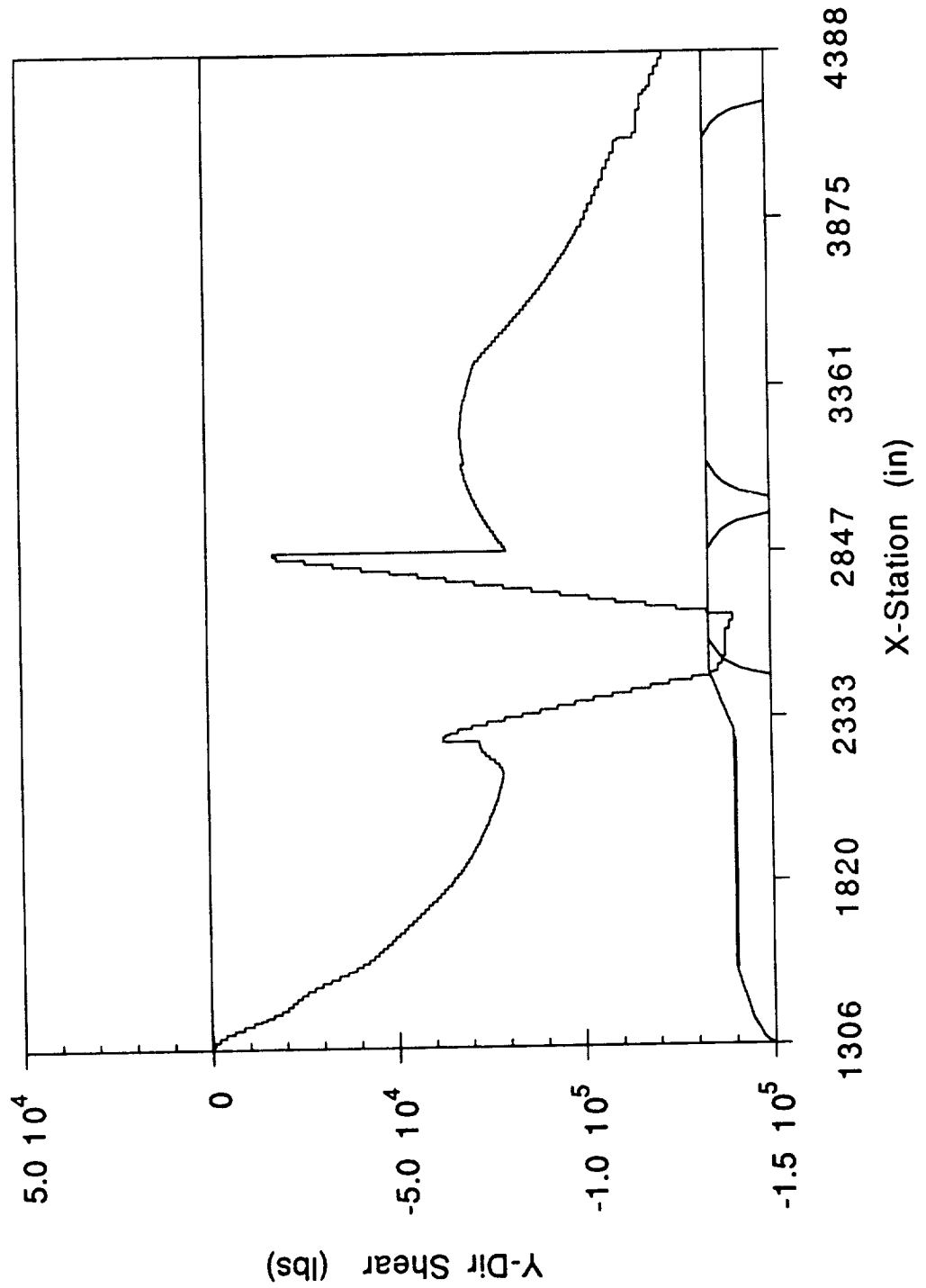

**NLS2 CORE - 14 km ENGINE OUT
Z-DIR SHEAR vs X-STATION**

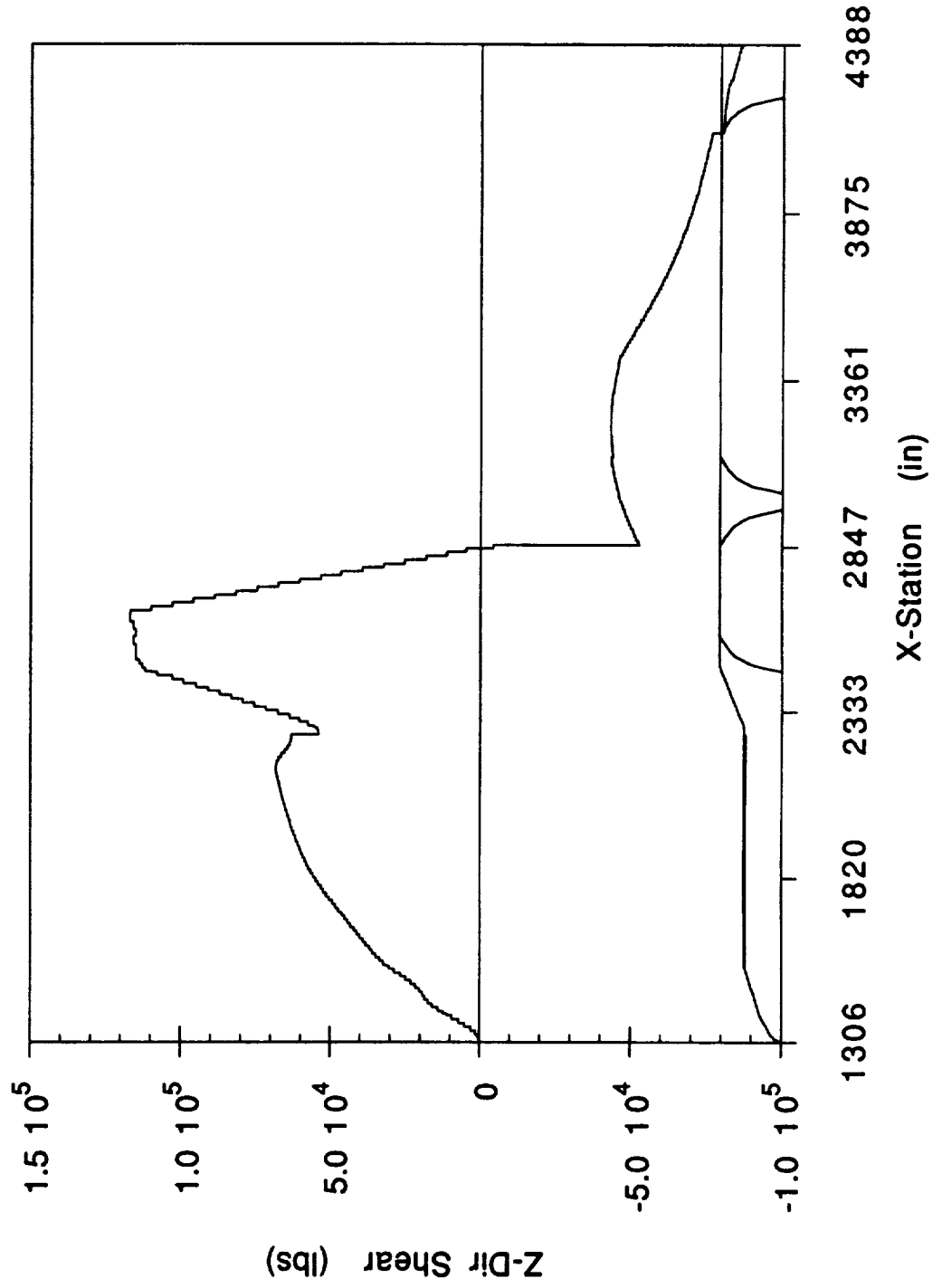

**NLS2 CORE - 14 km ENGINE OUT
Y-DIR MOMENT vs X-STATION**

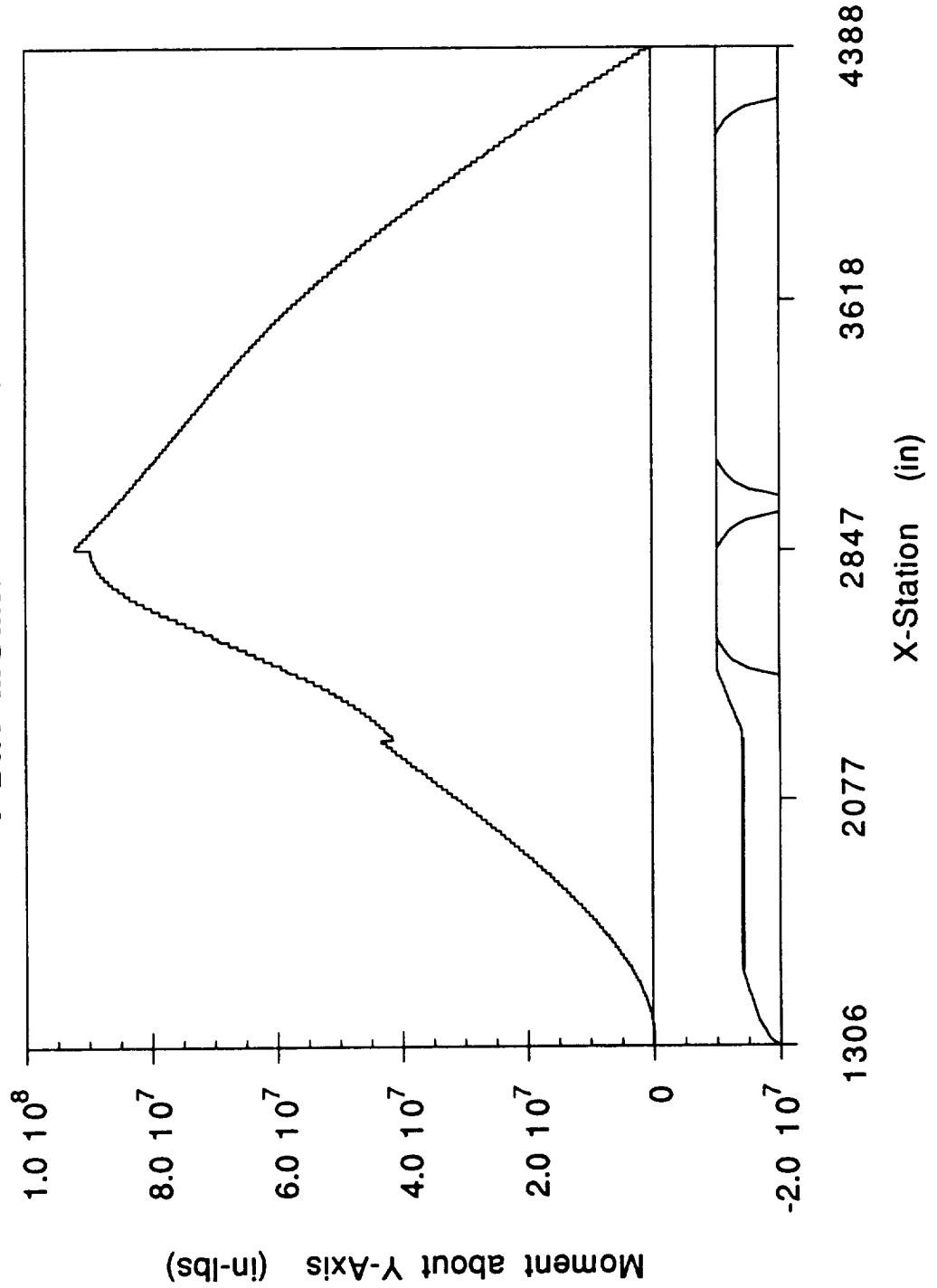

NLS2 CORE - 14 km ENGINE OUT Z-DIR MOMENT vs X-STATION

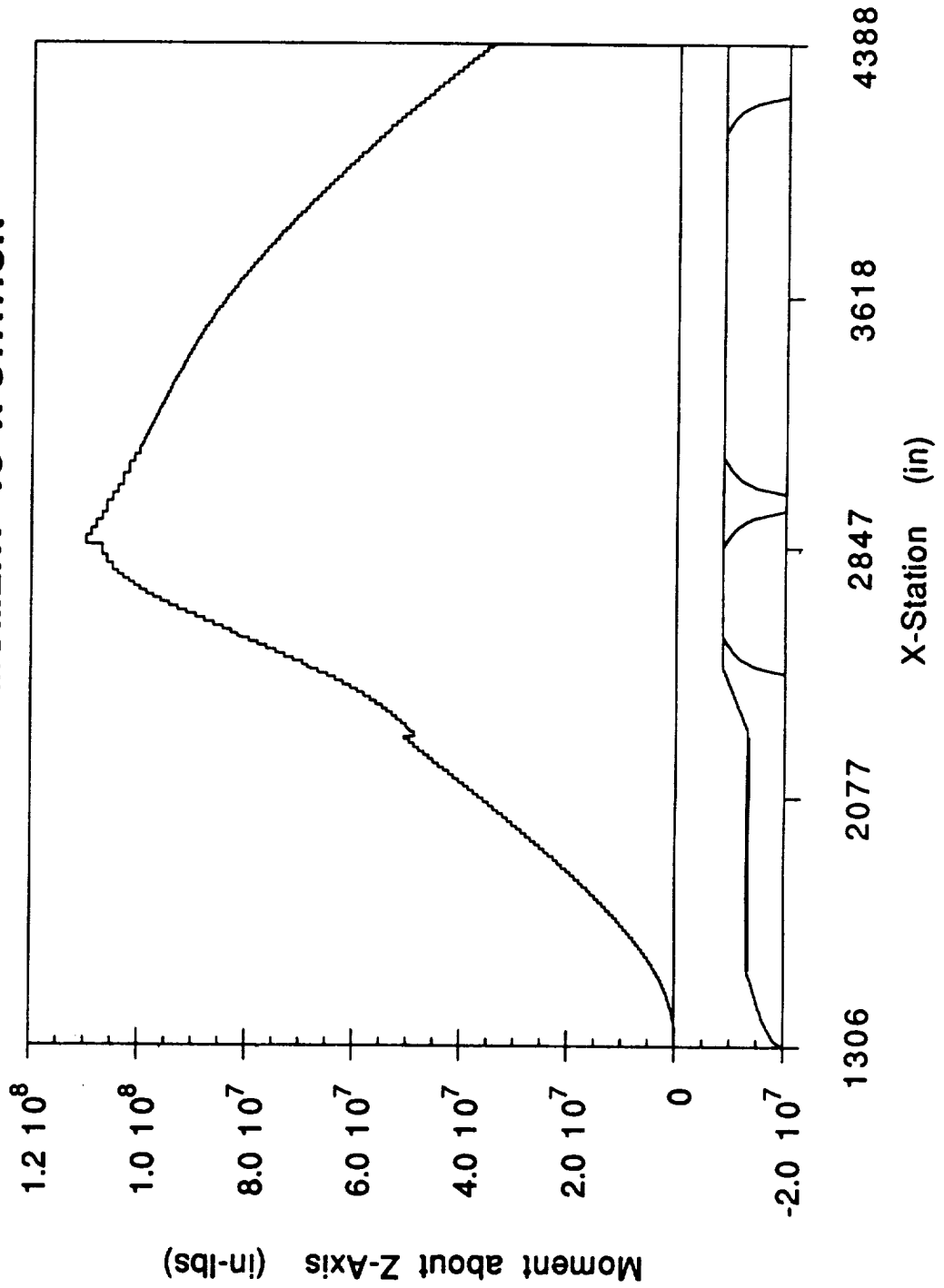

((

NLS2 CORE 14 km ENGINE OUT P EQUIVALENT vs X-STATION

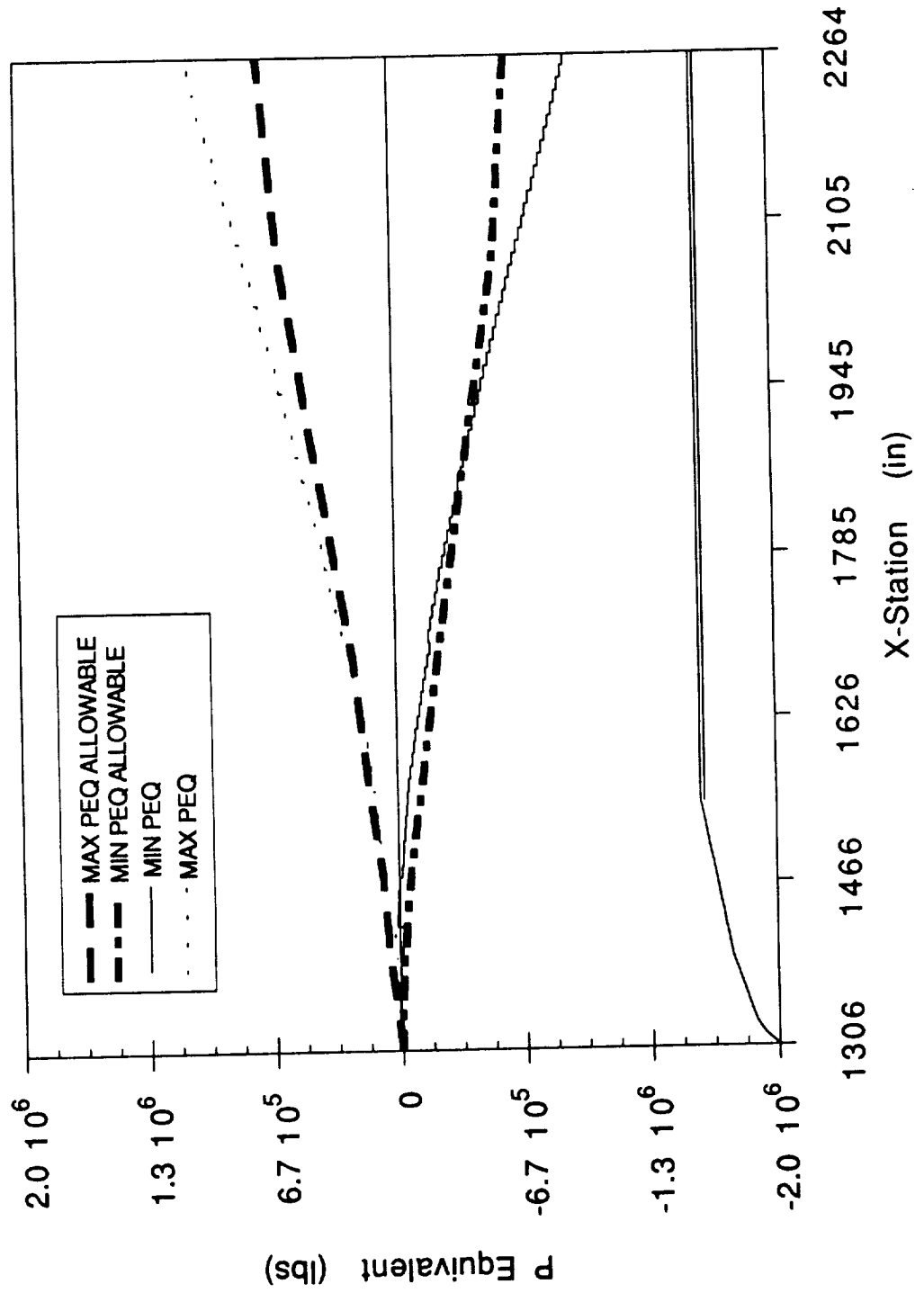

NLS2 CORE 14 km ENGINE OUT V EQUIVALENT vs X-STATION

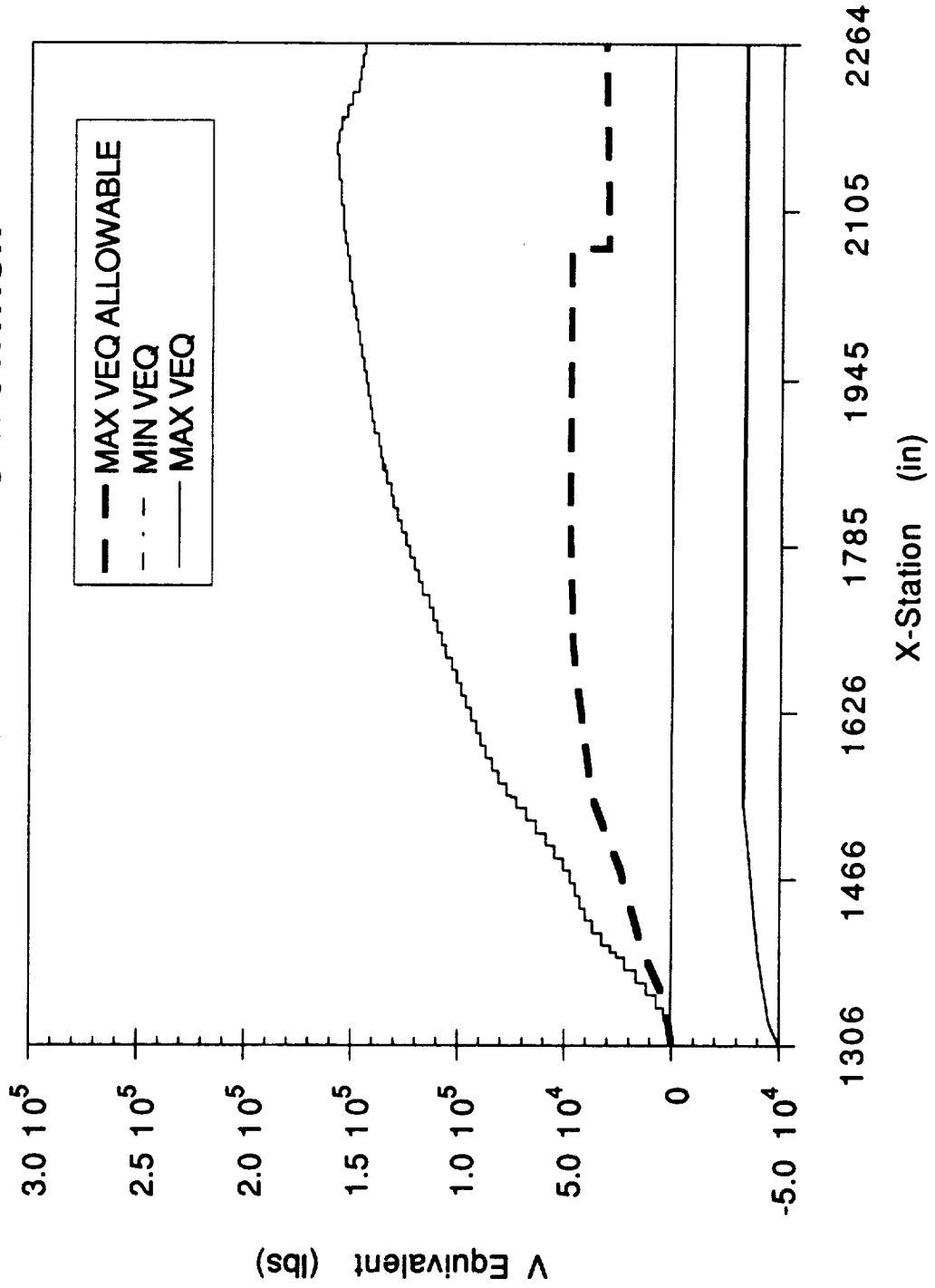

APPROVAL

**NATIONAL LAUNCH SYSTEM CYCLE I LOADS AND
MODELS DATA BOOK**

The information in this report has been reviewed for technical content. Review of any information concerning Department of Defense or nuclear energy activities or programs has been made by the MSFC Security Classification Officer. This report, in its entirety, has been determined to be unclassified.

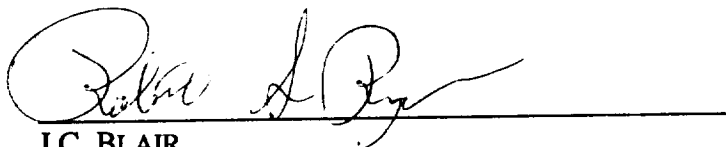
A handwritten signature in cursive script, appearing to read "J.C. Blair", is written over a horizontal line.

J.C. BLAIR
Director, Structures and Dynamics Laboratory

