

Kinematic Equations for Control of the Redundant Eight-Degree-of-Freedom Advanced Research Manipulator II

Robert L. Williams II
*Langley Research Center
Hampton, Virginia*



National Aeronautics and
Space Administration

Office of Management

Scientific and Technical
Information Program

1992

(NASA-TM-4377) KINEMATIC EQUATIONS
FOR CONTROL OF THE REDUNDANT
EIGHT-DEGREE-OF-FREEDOM ADVANCED
RESEARCH MANIPULATOR 2 (NASA)
28 p

N92-34146

Unclas

H1/63 0115668

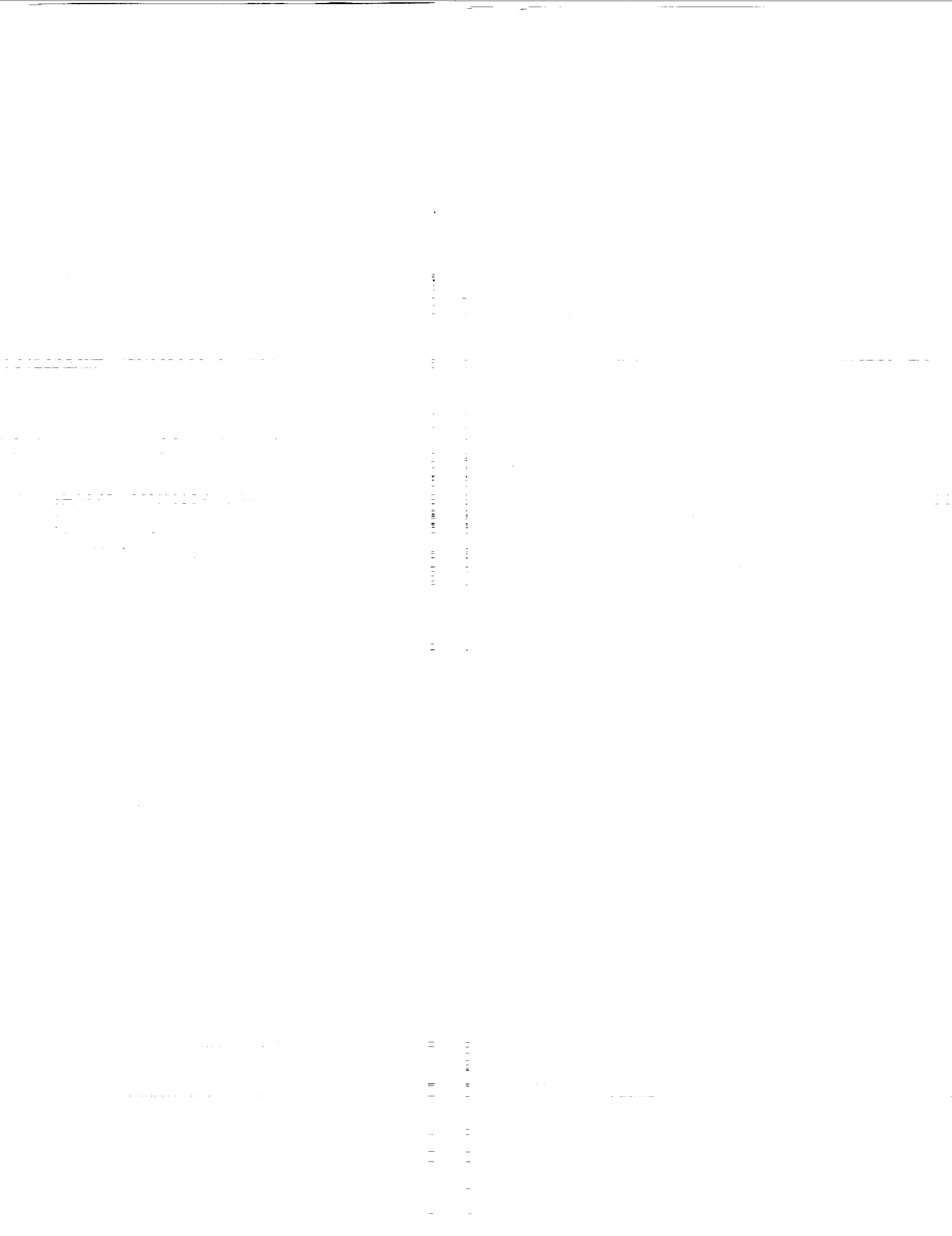

Summary

This paper presents the forward position kinematics (given the eight joint angles, how to find the Cartesian position and orientation of the end effector) and forward velocity kinematics (given the eight joint rates, how to find the Cartesian translational and rotational velocities of the end effector) for the redundant eight-degree-of-freedom Advanced Research Manipulator II (ARMII).

Inverse kinematic solutions, required to control the manipulator end effector, are also presented. For a redundant manipulator, the inverse kinematic solutions are not unique because they involve solving for eight unknowns (joint angles for inverse position and joint rates for inverse velocity) in only six equations. The approach in this paper is to specify two of the unknowns and solve for the remaining six unknowns. Two unknowns can be specified with two restrictions. First, the elbow joint angle and rate cannot be specified. The elbow joint angle is determined solely by the commanded position of the end effector. Likewise, the elbow joint rate is determined by the commanded Cartesian translational velocity of the end effector. Second, one unknown must be specified from the four-jointed wrist, while the second unknown must be specified from one of the arm joints (elbow joint excluded) that translate the wrist.

The inverse position solution has eight solutions for each set of two specified joint angles. No alternate inverse position solutions are presented for singular configurations. In the inverse velocity problem, with two specified joint rates, the solution is unique provided that the Jacobian matrix is nonsingular. A discussion of singularities is based on specifying two joint rates and analyzing the reduced Jacobian matrix. When the reduced Jacobian matrix is singular, the generalized inverse can be used to move the manipulator away from the singularity region.

With two redundant joints, the methods of this paper allow considerable freedom in solving the inverse kinematic problems. However, no control strategies are developed to move the manipulator. Control strategies are developed through ARMII hardware experience.

A symbolic manipulation computer program was used with existing standard methods in robotics for the derivation of the equations. In addition, computer simulations were developed to verify the equations. Examples demonstrate agreement between forward and inverse solutions.

1. Introduction

The Advanced Research Manipulator II (ARMII), a redundant research manipulator built by the AAI Corporation for NASA, is well suited for space tele-robotic applications and earth-based simulations of space telerobotic applications. The ARMII has several features that distinguish it from common industrial manipulators: (1) two redundant degrees of freedom, (2) high payload-to-weight ratio with a 40-lb design payload at a 60-in. reach, (3) modular joint design, (4) high joint and link stiffness with graphite-epoxy composite link material, (5) continuous bidirectional end-effector roll, (6) input and output joint position encoders, and (7) space flight qualified components. This paper presents kinematic equations that can be implemented for basic control of the ARMII.

NASA Langley Research Center has two ARMII's for investigation of redundant dual arm control and disturbance compensation for space operations. Figure 1 is a photograph and figure 2 is a schematic diagram of the ARMII, a redundant serial manipulator with eight revolute joints. For general spatial tasks, six degrees of freedom are required. The ARMII has two redundant joints; with this extra freedom, performance criteria can be satisfied in addition to the commanded motion. The use of this redundancy is not presented in this paper; however, references 1 to 8 present control methods for redundant manipulators. These references use manipulator redundancy to satisfy performance criteria, such as singularity avoidance, joint limit avoidance, minimization of joint rates, minimization of manipulator energy, and optimization of manipulator configuration.

The ARMII forward position, inverse position, forward velocity, and inverse velocity problems are formulated and solved in this paper. The forward solutions are given for all eight degrees of freedom. The term *forward position transformation* hereafter indicates both position and orientation. The inverse solutions involve six equations in eight unknowns. The inverse solutions in this paper require that two of the eight joint angles and rates are specified and then the remaining six joint angles and rates are solved. Joint angles and rates for different joints can be specified at each calculation step. Therefore, this approach is more general than one that locks two joints for all motion.

The forward position transformation is presented after a discussion of kinematic simplification. With

ORIGINAL PAGE
BLACK AND WHITE PHOTOGRAPH

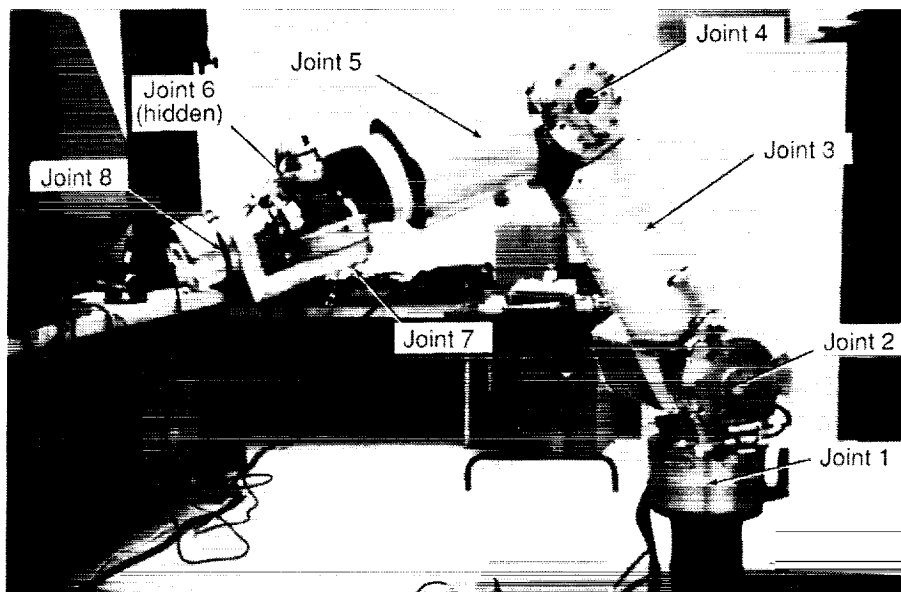

L-92-28

Figure 1. Advanced Research Manipulator II (ARMII).

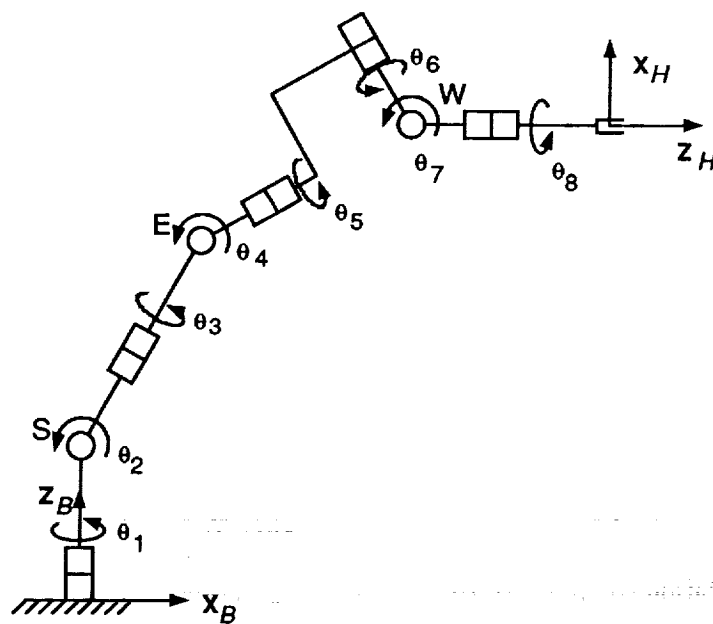

Figure 2. ARMII kinematic structure. $\{\theta\} = \{0, -30, 0, -30, 0, 0, -30, 0\}$.

the conventions of Craig (ref. 9), the Denavit-Hartenberg parameters and the homogeneous transformation matrices relating successive coordinate frames are presented. The forward position transformation is factored for efficient computation.

The inverse position solutions are presented next. Two angles are specified and the remaining six are solved. In this paper, one joint angle must be specified from the arm joints (1-3) and one from the wrist joints (5-8). Choosing two wrist joints is possible, but it leads to an underconstrained set of equations for the arm joints, and these equations are not dealt with in this paper. The elbow joint angle θ_4 is solved independently of the remaining joint angles and cannot be specified. The length of reach from the shoulder to the wrist determines the elbow joint angle θ_4 with two possible configurations, elbow up and elbow down. All twelve combinations of specified joints are allowed in the methods of this paper. For each combination, eight inverse position solutions exist.

The velocity solutions follow the position solutions. The forward velocity solution is a linear transformation from joint rates to Cartesian rates through the Jacobian matrix. The 6×8 Jacobian matrix is presented with respect to the base frame and with respect to the elbow frame. The Jacobian matrix with respect to the elbow frame involves less symbolic terms than any other frame for the ARMII. The computation of either Jacobian matrix involves terms from the forward position transformation.

The resolved motion rate, or inverse velocity, problem (ref. 10) is solved in a manner similar to the inverse position problem. Two joint rates are specified, one from the arm joints (1-3) and one from the wrist joints (5-8). The elbow joint rate $\dot{\theta}_4$ cannot be specified because it is uniquely determined by the Cartesian translational velocity command. The resolved motion rate problem is solved in closed form for the Jacobian matrix with respect to $\{4\}$. The inverse velocity solution is unique, provided that the Jacobian matrix has full rank. In this paper, singularity solutions are not presented; that is, the Jacobian matrix is assumed to have a rank of six.

An identification of ARMII singularities is based on specifying two joint rates in the resolved motion rate problem and analyzing the reduced Jacobian matrix. Singularity conditions are presented for all specified joint combinations. No alternate singularity solutions are developed.

Examples are presented to demonstrate the equations for all solutions given in this paper. For both

position and velocity kinematics, the forward solution output is the inverse solution input used to verify the results.

The methods used for derivation of the forward kinematic equations in this paper are existing standard methods in robotics. A computer symbolic manipulation program was used extensively for derivation of the equations. In addition, computer simulations were developed to verify the equations. The inverse position solutions are original work based on an adaptation and extension of reference 11. The principal contribution of this paper is the first presentation of efficient position and velocity kinematic equations for the ARMII.

2. Symbols

ARMII	Advanced Research Manipulator II
a_{i-1}	Denavit-Hartenberg parameter
c_i	$\cos \theta_i$
d_i	Denavit-Hartenberg parameter
d_3, d_5	Denavit-Hartenberg parameters, fixed manipulator lengths
J_{ij}	element (i, j) of Jacobian matrix
\mathbf{J}^*	Moore-Penrose pseudoinverse of Jacobian matrix
K_i, KK_i	factored terms
L_1	length from base to shoulder
L_8	length from wrist to end effector
${}^m\mathbf{J}$	Jacobian matrix expressed in $\{m\}$
${}^m\mathbf{J}_{LL}$	lower left partition of ${}^m\mathbf{J}$
${}^m\mathbf{J}_{LR}$	lower right partition of ${}^m\mathbf{J}$
${}^m\mathbf{J}_{LRj}$	${}^m\mathbf{J}_{LR}$ with column j removed
${}^m\{\mathbf{J}_{LRj}\}$	column j of ${}^m\mathbf{J}_{LR}$
${}^m\mathbf{J}_{UL}$	upper left partition of ${}^m\mathbf{J}$
${}^m\mathbf{J}_{UR}$	upper right partition of ${}^m\mathbf{J}$
${}^m\{\mathbf{J}_{ULi}\}$	column i of ${}^m\mathbf{J}_{UL}$ with row 1 removed
${}^m\mathbf{J}_{ULi4}$	${}^m\mathbf{J}_{UL}$ with columns i and 4, plus row 1 removed
$\ P\ $	Euclidean norm of vector \mathbf{P}
$\{{}^n\mathbf{P}_m\}$	position vector from origin of $\{n\}$ to $\{m\}$, expressed in $\{n\}$
$\{P_X, P_Y, P_Z\}^T$	components of $\{{}^0\mathbf{P}_8\}$

${}^n_m\mathbf{R}$	orthonormal rotation matrix of $\{m\}$ relative to $\{n\}$
R_{ij}	element (i, j) of ${}^0_8\mathbf{R}$
r_{ij}	element (i, j) of ${}^4_8\mathbf{R}$
s_i	$\sin \theta_i$
${}^n_m\mathbf{T}$	homogeneous transformation matrix of $\{m\}$ relative to $\{n\}$
t_i	$\tan \theta_i$
$\{{}^n\mathbf{v}_k\}$	linear velocity from origin of $\{k\}$ with respect to $\{0\}$, expressed in $\{m\}$
$\mathbf{X}_m, \mathbf{Y}_m, \mathbf{Z}_m$	unit direction vectors of $\{m\}$
${}^m\{\dot{X}\}$	${}^m\{\dot{x}, \dot{y}, \dot{z}, \omega_x, \omega_y, \omega_z\}^T$, $\{\{{}^m\mathbf{v}_8\}, \{{}^m\omega_8\}\}^T$
α_{i-1}	Denavit-Hartenberg parameter
θ_i	joint angle i
$\{\theta\}$	eight ARMII joint angles, arm, and wrist (1-8)
$\{\theta\}_A$	$\{\theta_1, \theta_2, \theta_3, \theta_4\}^T$, four arm joint angles (1-4)
$\{\theta\}_W$	$\{\theta_5, \theta_6, \theta_7, \theta_8\}^T$, four wrist joint angles (5-8)
$\dot{\theta}_i$	joint rate i
$\{\dot{\theta}\}$	eight ARMII joint rates, arm, and wrist (1-8)
$\{\dot{\theta}\}_A$	arm joint rates
$\{\dot{\theta}\}_{Ai4}$	arm joint rates, excluding i and 4
$\{\dot{\theta}\}_W$	wrist joint rates
$\{\dot{\theta}\}_{Wj}$	wrist joint rates, excluding j
$\{{}^m\omega_k\}$	angular velocity of $\{k\}$ with respect to $\{0\}$, expressed in $\{m\}$

Mathematical notation:

$\{ \}$	Cartesian coordinate frame
$\{.,.,.,.,.\}^T$	vector components

Arm reference points:

S	shoulder
E	elbow

W wrist

Coordinate frames:

B	base
H	end effector
m	dextral
0	base for simplified kinematic equations
4	elbow
8	end effector for simplified kinematic equations

3. Kinematic Simplification

3.1. Base and End-Effector Coordinate Frames

For telerobotic tasks, the position and orientation of the end-effector coordinate frame $\{H\}$ are controlled with respect to the base coordinate frame $\{B\}$. The symbolic terms for the forward position transformation and Jacobian matrix require significantly less calculations when $\{8\}$ is controlled with respect to $\{0\}$. The origin of $\{8\}$ is located at the wrist point W and the origin of $\{0\}$ is located at the shoulder point S. (See fig. 3.) This removes L_1 and L_8 from the basic kinematic equations. No loss of generality is incurred because control of $\{H\}$ with respect to $\{B\}$ is transformed to control of $\{8\}$ with respect to $\{0\}$ through equations (1), (2), and (3). Given ${}^B_H\mathbf{T}$, ${}^0_8\mathbf{T}$ is calculated by the following equation:

$${}^0_8\mathbf{T} = {}^B_0\mathbf{T}^{-1} {}^B_H\mathbf{T} {}^8_H\mathbf{T}^{-1} \quad (1)$$

where

$${}^B_0\mathbf{T}^{-1} = \begin{bmatrix} 1 & 0 & 0 & 0 \\ 0 & 1 & 0 & 0 \\ 0 & 0 & 1 & -L_1 \\ 0 & 0 & 0 & 1 \end{bmatrix}$$

$${}^8_H\mathbf{T}^{-1} = \begin{bmatrix} 1 & 0 & 0 & 0 \\ 0 & 1 & 0 & 0 \\ 0 & 0 & 1 & -L_8 \\ 0 & 0 & 0 & 1 \end{bmatrix}$$

Given the Cartesian translational and rotational velocities $\{{}^H\mathbf{v}_H\}$ and $\{{}^H\omega_H\}$, the equivalent Cartesian velocity command at $\{8\}$ is calculated as

$$\{{}^8\omega_8\} = \{{}^H\omega_H\} \quad (2)$$

$$\{{}^8\mathbf{v}_8\} = \{{}^H\mathbf{v}_H\} - \{{}^8\omega_8\} \times \{{}^8\mathbf{P}_H\} \quad (3)$$

where $\{{}^8\mathbf{P}_H\} = \{0, 0, L_8\}^T$. A velocity transformation is not required between $\{B\}$ and $\{0\}$ because no relative motion occurs. Equations (1), (2), and (3)

are written for the inverse position and velocity problems. The same equations can be modified for use in the forward position and velocity problems.

3.2. Decoupling Position From Orientation

An efficient method for calculating kinematic solutions of manipulators with spherical wrist mechanisms is to decouple the position from the orientation. The arm joint angles position W in space and the wrist joint angles orient $\{8\}$ with respect to $\{4\}$. The wrist joint rotations do not affect the positioning of the arm joints. The ARMII has a four-axis spherical wrist. Decoupling the position from the orientation applies to both position and velocity problems.

From reference 9, the general form of 0_8T is

$${}^0_8T = \begin{bmatrix} {}^0_8R & \{^0P_8\} \\ 0 & 1 \end{bmatrix} \quad (4)$$

Equation (4) gives the decoupling of the position from the orientation as follows. Because the spherical wrist causes no translations, the position vector $\{^0P_8\}$ is a function of only the arm joint angles. The manipulator orientation is provided by the wrist joint angles relative to the orientation of $\{4\}$.

The terms for the forward position transformation, equation (4), are presented in the next section. The position vector $\{^0P_8\}$ is expressed as a function of $\theta_1, \theta_2, \theta_3,$ and θ_4 . The rotation matrix representing the manipulator orientation is given as a function of all joint angles.

The Jacobian matrix used in velocity kinematics has the following form when the wrist is spherical:

$$J = \begin{bmatrix} J_{UL} & 0 \\ J_{LL} & J_{LR} \end{bmatrix} \quad (5)$$

The wrist joint rates do not affect the translational Cartesian velocity of the end effector; thus, the upper-right portion of the Jacobian matrix is the zero matrix. The Cartesian angular velocity is a function of all joint rates.

4. Position Kinematics

4.1. Forward Position Kinematics

4.1.1. Denavit-Hartenberg parameters. Figure 3 defines the coordinate frames for the ARMII.

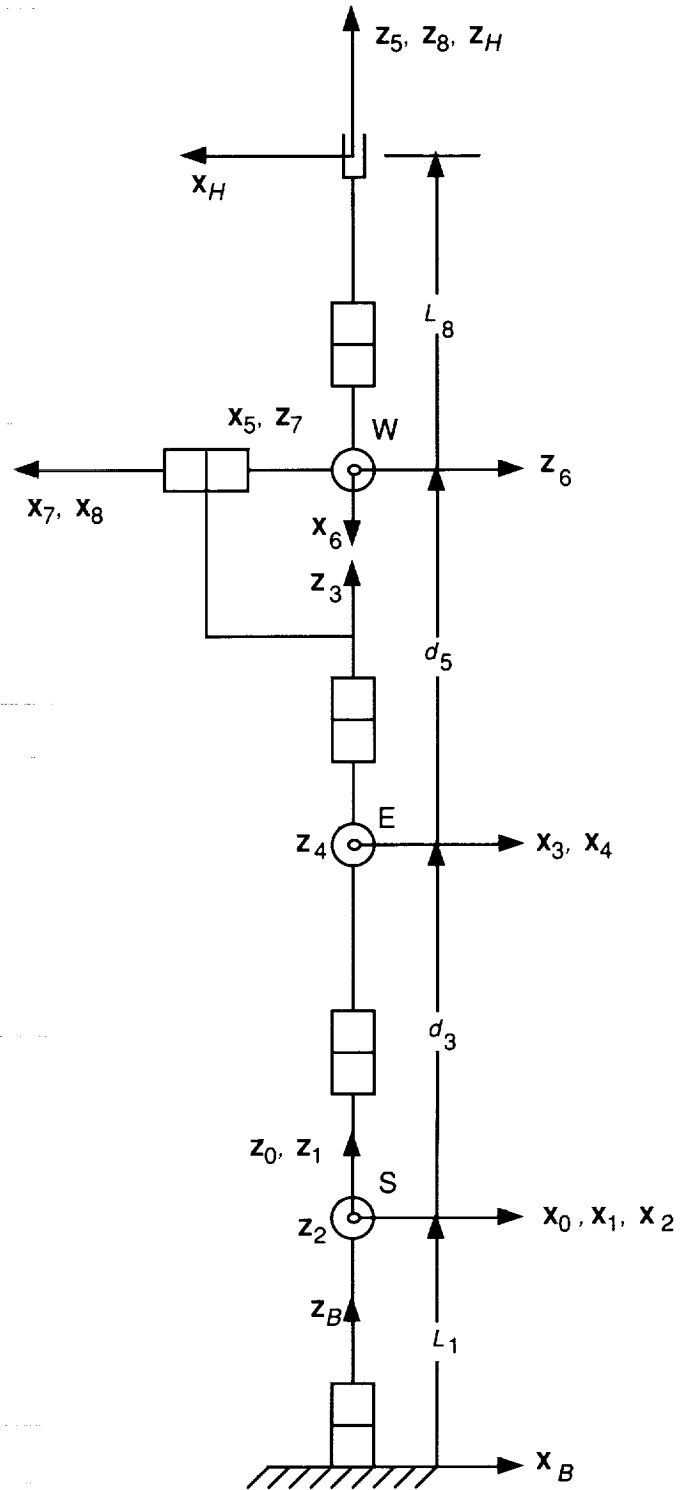

Figure 3. ARMII coordinate frames. $\{\theta\} = \{0, 0, 0, 0, 0, 0, 0, 0\}$.

The manipulator pose in figure 3 is the initial position where all joint angles are 0. The $X_0, X_1,$ and X_2 axes are coincident in the initial position. The same is true of X_3 and X_4 and also X_7 and X_8 .

The Z_2 , Z_4 , and Z_7 axes are directed outward, perpendicular to the plane of the paper. For these coordinate frame definitions, the eight sets of Denavit-Hartenberg parameters relating the nine successive coordinate frames $\{0\}$ through $\{8\}$ are given in table 1. With the simplification presented in section 3.1, the parameters d_1 and d_8 are both 0. In figure 3, the lengths from the base to the shoulder and the wrist to the end effector are labelled L_1 and L_8 to avoid confusion with the Denavit-Hartenberg parameters d_1 and d_8 . The joint variables θ_i are the angles from X_{i-1} to X_i measured about Z_i . Joints five, six, and seven require the offsets given in table 1 for θ_5 , θ_6 , and θ_7 to be 0 in the initial configuration of figure 3.

Table 1. Denavit-Hartenberg Parameters

i	α_{i-1}	a_{i-1}	d_i	θ_i
1	0	0	0	θ_1
2	90°	0	0	θ_2
3	-90°	0	d_3	θ_3
4	90°	0	0	θ_4
5	-90°	0	d_5	$\theta_5 - 90^\circ$
6	-90°	0	0	$\theta_6 + 90^\circ$
7	90°	0	0	$\theta_7 - 90^\circ$
8	90°	0	0	θ_8

Nominal values for the fixed lengths are $d_3 = 762.0$ mm and $d_5 = 495.3$ mm. The fixed length L_1 depends on the manipulator mounting and L_8 depends on the end effector. Nominal joint limits are given in appendix A.

4.1.2. Homogeneous transformation matrices. The general homogeneous transformation matrix (ref. 9) represents the position and orientation of $\{i\}$ with respect to $\{i-1\}$ and is given as follows:

$${}^{i-1}\mathbf{T}_i = \begin{bmatrix} c\theta_i & -s\theta_i & 0 & a_{i-1} \\ s\theta_i c\alpha_{i-1} & c\theta_i c\alpha_{i-1} & -s\alpha_{i-1} & -d_i s\alpha_{i-1} \\ s\theta_i s\alpha_{i-1} & c\theta_i s\alpha_{i-1} & c\alpha_{i-1} & d_i s\alpha_{i-1} \\ 0 & 0 & 0 & 1 \end{bmatrix} \quad (6)$$

The Denavit-Hartenberg parameters are substituted into equation (6) to produce eight homogeneous transformation matrices (given in appendix B) that relate successive coordinate frames.

4.1.3. Forward position transformation. The forward position transformation is a unique mapping from joint space to Cartesian space:

$${}^0\mathbf{T} = {}^0\mathbf{T}_1(\theta_1) {}^1\mathbf{T}_2(\theta_2) {}^2\mathbf{T}_3(\theta_3) \dots {}^7\mathbf{T}_8(\theta_8) \quad (7)$$

Substituting the matrices of appendix B into equation (7) yields

$${}^0\mathbf{T}_8 = \begin{bmatrix} K_N s_8 - K_T c_8 & K_T s_8 + K_N c_8 & K_U & -d_3 c_1 s_2 - d_5 K_A \\ K_Q s_8 - K_V c_8 & K_V s_8 + K_Q c_8 & K_W & -d_3 s_1 s_2 - d_5 K_C \\ K_S s_8 - K_X c_8 & K_X s_8 + K_S c_8 & K_Y & d_3 c_2 - d_5 K_6 \\ 0 & 0 & 0 & 1 \end{bmatrix} \quad (8)$$

Common terms K_i , reported in appendix C, are factored out to reduce computation time. Based on decoupling the position from the orientation, discussed in section 3.2, the forward position transformation is partitioned at $\{4\}$ as follows:

$${}^0\mathbf{T} = {}^0\mathbf{T}_4(\theta_1, \theta_2, \theta_3, \theta_4) {}^4\mathbf{T}_8(\theta_5, \theta_6, \theta_7, \theta_8) \quad (9)$$

where

$${}^4\mathbf{T} = \begin{bmatrix} K_B & -K_A & K_2 & -d_3 c_1 s_2 \\ K_D & -K_C & K_4 & -d_3 s_1 s_2 \\ K_5 & -K_6 & s_2 s_3 & d_3 c_2 \\ 0 & 0 & 0 & 1 \end{bmatrix}$$

$${}^4\mathbf{T}_8 = \begin{bmatrix} s_5 c_6 s_8 - K K_4 c_8 & K K_4 s_8 + s_5 c_6 c_8 & K K_3 & 0 \\ K K_5 & K K_6 & c_6 c_7 & d_5 \\ c_5 c_6 s_8 + K K_2 c_8 & -K K_2 s_8 + c_5 c_6 c_8 & K K_1 & 0 \\ 0 & 0 & 0 & 1 \end{bmatrix}$$

The $K K_i$ terms are defined in appendix C.

4.1.4. Geometric arm joint redundancy. Figure 4 presents the geometric interpretation of the arm joint redundancy for the ARMII. The arm

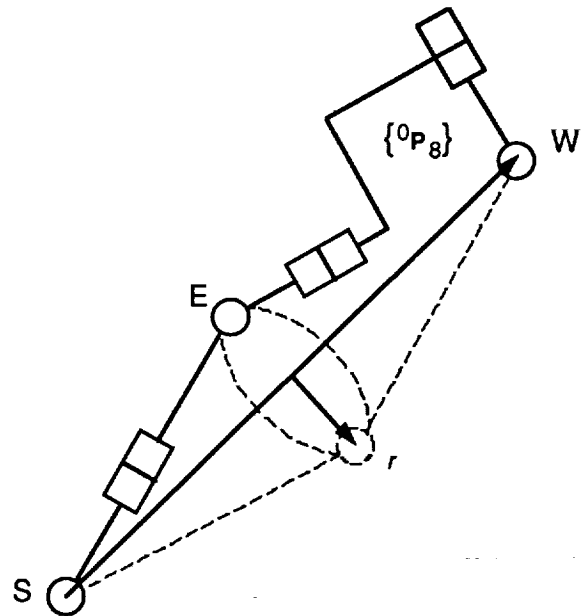

Figure 4. Geometric interpretation of ARMII arm joint redundancy.

redundancy or self-motion is the rotation of the elbow point E about $\{^0\mathbf{P}_8\}$. A given Cartesian position and orientation is reachable at any of these locations of E. The radius of this rotation r varies with $\{^0\mathbf{P}_8\}$. The wrist joint redundancy provides a freedom in addition to this self-motion behavior.

4.2. Inverse Position Kinematics

The inverse position problem is a mapping from Cartesian space to joint angle space. This problem is more complicated than the forward problem because it involves coupled transcendental equations with multiple solutions. The inverse position problem calculates $\theta_1, \theta_2, \dots, \theta_8$ for the ARMII, when given the following Cartesian position and orientation command ${}^0_8\mathbf{T}$:

$${}^0_8\mathbf{T} = \begin{bmatrix} R_{11} & R_{12} & R_{13} & P_X \\ R_{21} & R_{22} & R_{23} & P_Y \\ R_{31} & R_{32} & R_{33} & P_Z \\ 0 & 0 & 0 & 1 \end{bmatrix} \quad (10)$$

Equation (8) expresses ${}^0_8\mathbf{T}$ in terms of the unknown joint angles. Equations (10) and (8) are equated to obtain the inverse position equations. This equating yields twelve scalar equations, only six of which are independent. The six independent equations come from the three position terms and three of the possible nine rotation matrix terms.

The inverse position problem cannot be solved for redundant manipulators without additional constraints. The specified Cartesian location has six degrees of freedom but eight one-degree-of-freedom joints. For the ARMII, the inverse position problem is an underconstrained set of six equations in eight unknowns. In this section, the inverse position problem is solved by specifying two joint angles.

Decoupling of the position from the orientation is utilized in the inverse solutions. The arm joint angles are solved from the position command $\{^0\mathbf{P}_8\}$. The orientation command and the influence of arm joint angles on the orientation are then used to solve for the wrist joint angles. Therefore, the inverse equations are two sets of three equations in four unknowns. One joint angle is specified from the arm joints and one from the wrist joints. These methods are an adaptation and extension of reference 11.

4.2.1. Inverse position solutions for arm joint angles. Multiple solutions for $\{\theta_1, \theta_2, \theta_3, \theta_4\}^T$ are obtained in this section with $\{^0\mathbf{P}_8\}$ given. A geometric approach is used to solve for θ_4 first, independently of $\{\theta_1, \theta_2, \theta_3\}^T$ and $\{\theta_5, \theta_6, \theta_7, \theta_8\}^T$.

The vector $\{^0\mathbf{P}_8\}$ gives the position of the wrist W with respect to the shoulder S, as shown in figure 5. This length-of-reach constraint fixes the value of θ_4 . The plane of triangle SEW is perpendicular to \mathbf{Z}_4 for all manipulator configurations. The law of cosines is used to solve θ_4 so that

$$\|\{^0\mathbf{P}_8\}\|^2 = d_3^2 + d_5^2 - 2d_3d_5 \cos \phi \quad (11)$$

where $\|\{^0\mathbf{P}_8\}\|^2 = P_X^2 + P_Y^2 + P_Z^2$ and $\phi = \pi - \theta_4$. The two θ_4 solutions to equation (11) are as follows:

$$\theta_4 = \pm \cos^{-1} \left[\frac{\|\{^0\mathbf{P}_8\}\|^2 - d_3^2 - d_5^2}{2d_3d_5} \right] \quad (12)$$

These solutions correspond to the elbow up and elbow down configurations.

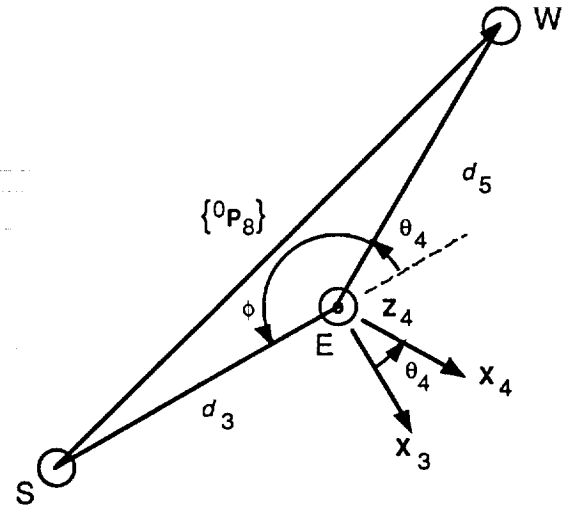

Figure 5. Geometric method to calculate θ_4 .

A geometric method is used to determine whether a given position command is within the manipulator workspace. The maximum reach occurs when d_3 and d_5 align ($\theta_4 = 0$). At the minimum reach, d_5 folds back upon d_3 ($\theta_4 = \pi$). Based on these conditions, the following inequalities must be satisfied for $\{^0\mathbf{P}_8\}$ to be reachable:

$$|d_3 - d_5| \leq \|\{^0\mathbf{P}_8\}\| \leq d_3 + d_5 \quad (13)$$

This analysis ignores joint angle θ_4 limits, which cause a more restricted workspace.

The remaining arm joint angles $\{\theta_1, \theta_2, \theta_3\}^T$ are solved with algebra and trigonometry. The wrist mechanism is spherical; thus $\{^0\mathbf{P}_5\}$ equals $\{^0\mathbf{P}_8\}$. Equations for $\{\theta_1, \theta_2, \theta_3\}^T$ are obtained from the identity

$$\{^0\mathbf{P}_5\} = {}^0_4\mathbf{R}(\theta_1, \theta_2, \theta_3, \theta_4)\{^4\mathbf{P}_5\} \quad (14)$$

where $\{^0\mathbf{P}_5\} = \{P_X, P_Y, P_Z\}^T$ is the position command and $\{^4\mathbf{P}_5\} = \{0, d_5, 0\}^T$ is known. Equation (14) is rewritten as

$${}^2\mathbf{R}(\theta_1, \theta_2)\{^0\mathbf{P}_5\} = {}^4\mathbf{R}(\theta_3, \theta_4)\{^4\mathbf{P}_5\} \quad (15a)$$

and expands to the following three scalar equations:

$$(P_X c_1 + P_Y s_1)c_2 + P_Z s_2 = -d_5 c_3 s_4 \quad (15b)$$

$$-(P_X c_1 + P_Y s_1)s_2 + P_Z c_2 = d_3 + d_5 c_4 \quad (15c)$$

$$P_X s_1 - P_Y c_1 = d_5 s_3 s_4 \quad (15d)$$

Equations (15b), (15c), and (15d) can apparently be solved for the three unknowns $(\theta_1, \theta_2, \theta_3)$ because θ_4 is known. However, squaring equations (15b), (15c), and (15d) and adding them gives the cosine law used previously to solve θ_4 . Therefore, equations (15b), (15c), and (15d) are two independent equations in three unknowns. One joint unknown is specified and the other two are solved. Three cases are presented that correspond to specified θ_1 , θ_2 , or θ_3 . For each case, θ_4 is known from equation (12).

Case 1. With θ_1 specified, equation (15c), rewritten in the following equation, is solved for θ_2 as follows:

$$E \cos \theta_2 + F \sin \theta_2 + G = 0 \quad (16)$$

where

$$E = -P_Z$$

$$F = P_X c_1 + P_Y s_1$$

$$G = d_3 + d_5 c_4$$

Equations of the form in equation (16) arise often in inverse position kinematics. The solution is obtained with the tangent half-angle substitution (ref. 13). Appendix D presents the two valid solutions for the general form of equation (16) with this method.

A ratio of equations (15d) and (15b) is used to solve for θ_3 . The quadrant-specific inverse tangent function is used to provide a unique result from the following equation:

$$\theta_3 = \tan^{-1} \left[\frac{P_X s_1 - P_Y c_1}{-(P_X c_1 + P_Y s_1)c_2 - P_Z s_2} \right] \quad (17)$$

Two θ_4 solutions are given in equation (12). For each θ_4 , two θ_2 solutions are obtained from equation (16). Each θ_2 has one θ_3 solution (eq. (17)). Therefore, four solutions exist for the arm joint angles, with the joint limits ignored. The four solutions have the structure shown in table 2.

Table 2. Arm Joint Solutions With θ_1 Specified

n	θ_1	θ_2	θ_3	θ_4
1	θ_1	θ_{21}	θ_3	θ_4
2	θ_1	θ_{22}	$-\theta_3 + \pi$	θ_4
3	θ_1	θ_{22}	$-\theta_3$	$-\theta_4$
4	θ_1	θ_{21}	$\theta_3 + \pi$	$-\theta_4$

Case 2. With θ_2 specified, equation (15c) is solved to yield two values of θ_1 :

$$E \cos \theta_1 + F \sin \theta_1 + G = 0 \quad (18)$$

where

$$E = P_X s_2$$

$$F = P_Y s_2$$

$$G = d_3 + d_5 c_4 - P_Z c_2$$

The angle θ_3 is again calculated by equation (17). Table 3 gives the solution structure when θ_2 is specified.

Table 3. Arm Joint Solutions With θ_2 Specified

n	θ_1	θ_2	θ_3	θ_4
1	θ_{11}	θ_2	θ_3	θ_4
2	θ_{12}	θ_2	$-\theta_3$	θ_4
3	θ_{11}	θ_2	$\theta_3 + \pi$	$-\theta_4$
4	θ_{12}	θ_2	$-\theta_3 + \pi$	$-\theta_4$

Case 3. With θ_3 specified, both θ_3 and θ_4 are known. Equations (15) are rewritten to separate the unknowns θ_1 and θ_2 as follows:

$${}^1\mathbf{R}\{^0\mathbf{P}_5\} = {}^4\mathbf{R}\{^4\mathbf{P}_5\} \quad (19a)$$

$$P_X c_1 + P_Y s_1 = -(d_5 c_3 s_4)c_2 - (d_3 + d_5 c_4)s_2 \quad (19b)$$

$$P_Y c_1 - P_X s_1 = -d_5 s_3 s_4 \quad (19c)$$

$$P_Z = (d_3 + d_5 c_4)c_2 - (d_5 c_3 s_4)s_2 \quad (19d)$$

Equation (19c) is solved for two values of θ_1 , independently of θ_2 , as follows:

$$E \cos \theta_1 + F \sin \theta_1 + G = 0 \quad (20)$$

where

$$E = P_Y$$

$$F = -P_X$$

$$G = d_5 s_3 s_4$$

Equation (19d) is solved for two values of θ_2 , independently of θ_1 , as follows:

$$E \cos \theta_2 + F \sin \theta_2 + G = 0 \quad (21)$$

where

$$\begin{aligned} E &= -(d_3 + d_5 c_4) \\ F &= d_5 c_3 s_4 \\ G &= P_Z \end{aligned}$$

Equations (19c) and (19d) are solved given each of the two θ_4 values from equation (12). There are eight possible solutions for sets of θ_1 , θ_2 , and θ_4 , but only four are valid. For each value of θ_4 , equation (19b)

is used to determine which θ_2 value corresponds to each θ_1 . The solution structure is given in table 4.

Table 4. Arm Joint Solutions With θ_3 Specified

n	θ_1	θ_2	θ_3	θ_4
1	θ_{11}	θ_{21}	θ_3	θ_4
2	θ_{12}	θ_{22}	θ_3	θ_4
3	$\theta_{12} + \pi$	$-\theta_{22}$	θ_3	$-\theta_4$
4	$\theta_{11} + \pi$	$-\theta_{21}$	θ_3	$-\theta_4$

4.2.2. Inverse position solutions for wrist joint angles. This section presents an algebraic method to solve the orientation part of the inverse position problem. Sets of $\{\theta_5, \theta_6, \theta_7, \theta_8\}^T$ are solved given ${}^0_8\mathbf{R}$ and $\{\theta_1, \theta_2, \theta_3, \theta_4\}^T$.

The wrist joint angles orient $\{8\}$ with respect to $\{4\}$. The orientation of $\{4\}$ depends on $\{\theta_1, \theta_2, \theta_3, \theta_4\}^T$. The wrist orientation command ${}^4_8\mathbf{R}$ is calculated by the following equation:

$${}^4_8\mathbf{R} = {}^0_4\mathbf{R}^{-1} {}^0_8\mathbf{R} = \begin{bmatrix} r_{11} & r_{12} & r_{13} \\ r_{21} & r_{22} & r_{23} \\ r_{31} & r_{32} & r_{33} \end{bmatrix} \quad (22)$$

The elements of ${}^0_4\mathbf{R}$ are given in equation (9b). The wrist inverse position equations are obtained by equating ${}^4_8\mathbf{R}$ from equation (9) and equation (22). The unknowns are separated as follows:

$${}^4_6\mathbf{R}^{-1} {}^4_8\mathbf{R} = {}^6_8\mathbf{R} \quad (23)$$

The matrices for the left- and right-hand sides of equation (23) are

$$\begin{bmatrix} -r_{21}c_6 - (r_{31}c_5 + r_{11}s_5)s_6 & -r_{22}c_6 - (r_{32}c_5 + r_{12}s_5)s_6 & -r_{23}c_6 - (r_{33}c_5 + r_{13}s_5)s_6 \\ r_{21}s_6 - (r_{31}c_5 + r_{11}s_5)c_6 & r_{22}s_6 - (r_{32}c_5 + r_{12}s_5)c_6 & r_{23}s_6 - (r_{33}c_5 + r_{13}s_5)c_6 \\ r_{11}c_5 - r_{31}s_5 & r_{12}c_5 - r_{32}s_5 & r_{13}c_5 - r_{33}s_5 \end{bmatrix} \begin{bmatrix} s_7c_8 & -s_7s_8 & -c_7 \\ -s_8 & -c_8 & 0 \\ -c_7c_8 & c_7s_8 & -s_7 \end{bmatrix}$$

Equation (23) contains nine scalar equations in four unknowns, three of which are independent. For solution, one unknown joint angle is specified and the remaining three are calculated. Four cases are presented for specified θ_5 , θ_6 , θ_7 , or θ_8 .

Case 1. With θ_5 specified, the joint angle θ_6 is solved from the (2,3) element of equation (23). The quadrant-specific inverse tangent function is not required because θ_6 and $\theta_6 + \pi$ are both valid solutions. The θ_6 solution is

$$\theta_6 = \tan^{-1} \left[\frac{r_{33}c_5 + r_{13}s_5}{r_{23}} \right] \quad (24)$$

A ratio of equation (23) elements (3,3) and (1,3) yields θ_7 . The quadrant-specific inverse tangent function must be used because one valid θ_7 value exists for each θ_6 . Similarly, θ_8 is solved from the ratio of the elements (2,1) and (2,2) of equation (23):

$$\theta_7 = \tan^{-1} \left[\frac{r_{33}s_5 - r_{13}c_5}{r_{23}c_6 + (r_{33}c_5 + r_{13}s_5)s_6} \right] \quad (25)$$

$$\theta_8 = \tan^{-1} \left[\frac{(r_{31}c_5 + r_{11}s_5)c_6 - r_{21}s_6}{(r_{32}c_5 + r_{12}s_5)c_6 - r_{22}s_6} \right] \quad (26)$$

Two wrist solutions exist for each $\{\theta_1, \theta_2, \theta_3, \theta_4\}$ result. The solution structure is demonstrated in table 5.

Table 5. Wrist Joint Solutions With θ_5 Specified

n	θ_5	θ_6	θ_7	θ_8
1	θ_5	θ_6	θ_7	θ_8
2	θ_5	$\theta_6 + \pi$	$-\theta_7 + \pi$	$\theta_8 + \pi$

Case 2. With θ_6 specified, the joint angle θ_5 is solved from the (2,3) element of equation (23). The general solution for the following equation is presented in appendix D. Both θ_5 results are valid.

$$E \cos \theta_5 + F \sin \theta_5 + G = 0 \quad (27)$$

where

$$E = r_{33}c_6$$

$$F = r_{13}c_6$$

$$G = -r_{23}s_6$$

The wrist angles θ_7 and θ_8 are calculated by equations (25) and (26). One (θ_7, θ_8) pair exists for each θ_5 . The two wrist solutions are given in table 6.

Table 6. Wrist Joint Solutions With θ_6 Specified

n	θ_5	θ_6	θ_7	θ_8
1	θ_{51}	θ_6	θ_7	θ_{81}
2	θ_{52}	θ_6	$-\theta_7$	θ_{82}

Case 3. With θ_7 specified, the (3,3) element of equation (23) gives the following equation:

$$E \cos \theta_5 + F \sin \theta_5 + G = 0 \quad (28)$$

where

$$E = r_{13}$$

$$F = -r_{33}$$

$$G = s_7$$

Appendix D presents a solution method for equation (28). θ_5 has two valid solutions. The angle θ_6 is solved from the (2,3) element of equation (23) and is

$$\theta_6 = \tan^{-1} \left[\frac{r_{33}c_5 + r_{13}s_5}{r_{23}} \right] \quad (29)$$

The quadrant-specific inverse tangent function used to calculate one θ_6 is valid for each θ_5 . The wrist angle θ_8 is calculated by equation (26). One θ_8 exists for each θ_5 . Table 7 gives the two wrist solutions with θ_7 specified.

Table 7. Wrist Joint Solutions With θ_7 Specified

n	θ_5	θ_6	θ_7	θ_8
1	θ_{51}	θ_6	θ_7	θ_{81}
2	θ_{52}	$-\theta_6$	θ_7	θ_{82}

Case 4. With θ_8 specified, two values for θ_5 are solved from the ratio of the (3,1) and (3,2) elements of equation (23) as follows:

$$\theta_5 = \tan^{-1} \left[\frac{r_{12} + r_{11}t_8}{r_{32} + r_{31}t_8} \right] \quad (30)$$

Both θ_5 and $\theta_5 + \pi$ are valid results. The unique θ_6 is solved by equation (29). The wrist angle θ_7 is calculated by equation (25). For each θ_5 there is a unique θ_7 . Table 8 gives the two wrist solutions with θ_8 specified.

Table 8. Wrist Joint Solutions With θ_8 Specified

n	θ_5	θ_6	θ_7	θ_8
1	θ_5	θ_6	θ_7	θ_8
2	$\theta_5 + \pi$	$-\theta_6 + \pi$	$\theta_7 + \pi$	θ_8

4.2.3. Overall inverse position kinematic solutions. The overall inverse position problem has eight solutions: four arm joint solutions and two wrist solutions for each. This is true for all specified arm and wrist joint angle combinations. The overall solution structure is greater than the individual arm joint and wrist joint tables indicate. Table 9 presents the eight solutions obtained with θ_1 and θ_5 specified. Other combinations have a similar structure.

Table 9. Overall Solutions With θ_1 and θ_5 Specified

n	θ_1	θ_2	θ_3	θ_4	θ_5	θ_6	θ_7	θ_8
1	θ_1	θ_{21}	θ_3	θ_4	θ_5	θ_{61}	θ_{71}	θ_{81}
2	θ_1	θ_{21}	θ_3	θ_4	θ_5	$\theta_{61} + \pi$	$-\theta_{71} + \pi$	$\theta_{81} + \pi$
3	θ_1	θ_{22}	$-\theta_3 + \pi$	θ_4	θ_5	θ_{62}	θ_{72}	θ_{82}
4	θ_1	θ_{22}	$-\theta_3 + \pi$	θ_4	θ_5	$\theta_{62} + \pi$	$-\theta_{72} + \pi$	$\theta_{82} + \pi$
5	θ_1	θ_{22}	$-\theta_3$	$-\theta_4$	θ_5	$-\theta_{62}$	$-\theta_{72}$	$\theta_{82} + \pi$
6	θ_1	θ_{22}	$-\theta_3$	$-\theta_4$	θ_5	$-\theta_{62} + \pi$	$\theta_{72} + \pi$	θ_{82}
7	θ_1	θ_{21}	$\theta_3 + \pi$	$-\theta_4$	θ_5	$-\theta_{61}$	$-\theta_{71}$	$\theta_{81} + \pi$
8	θ_1	θ_{21}	$\theta_3 + \pi$	$-\theta_4$	θ_5	$-\theta_{61} + \pi$	$\theta_{71} + \pi$	θ_{81}

5. Velocity Kinematics

5.1. Forward Velocity Kinematics

The forward velocity problem calculates the Cartesian velocities given the joint rates. The Jacobian matrix is a linear operator that maps joint space velocities to Cartesian velocities as follows:

$${}^m\{\dot{X}\} = {}^m\mathbf{J}\{\dot{\theta}\} \quad (31)$$

In equation (31), ${}^m\{\dot{X}\}$ is the vector of Cartesian linear and angular velocities of {8} with respect to {0}, expressed in {m}. The dimension of $\{\dot{\theta}\}$ is eight for the ARMII. The Jacobian matrix order is 6×8 .

5.1.1. Jacobian matrix expressed in {0}. The Jacobian matrix form for $m = 0$ is as follows:

$${}^0\mathbf{J} = \begin{bmatrix} J_{11} & J_{12} & J_{13} & J_{14} & 0 & 0 & 0 & 0 \\ J_{21} & J_{22} & J_{23} & J_{24} & 0 & 0 & 0 & 0 \\ 0 & J_{32} & J_{33} & J_{34} & 0 & 0 & 0 & 0 \\ 0 & J_{42} & J_{43} & J_{44} & J_{45} & J_{46} & J_{47} & J_{48} \\ 0 & J_{52} & J_{53} & J_{54} & J_{55} & J_{56} & J_{57} & J_{58} \\ 1 & 0 & J_{63} & J_{64} & J_{65} & J_{66} & J_{67} & J_{68} \end{bmatrix} \quad (32)$$

The upper-right Jacobian submatrix is the zero matrix because the spherical wrist joint rates $\dot{\theta}_5$ through $\dot{\theta}_8$ do not affect the translational Cartesian velocity. The first column of the Jacobian matrix shows that $\dot{\theta}_1$ affects only ${}^0\dot{x}$, ${}^0\dot{y}$, and ${}^0\omega_z$. The term J_{61} equals 1 because $\dot{\theta}_1$ adds directly to ${}^0\omega_z$ in {0} coordinates. The term J_{62} equals 0 because $\dot{\theta}_2$ does not influence ${}^0\omega_z$. Because of the decoupling of the position from the orientation, the form of the Jacobian matrix is that of equation (5). The Jacobian matrix terms are

$${}^0\mathbf{J}_{UL} = \begin{bmatrix} d_3s_1s_2 + d_5K_C & -d_3c_1c_2 + d_5c_1K_6 & d_5K_2s_4 & -d_5K_B \\ -d_3c_1s_2 - d_5K_A & -d_3s_1c_2 + d_5s_1K_6 & d_5K_4s_4 & -d_5K_D \\ 0 & -K_Z & d_5s_2s_3s_4 & -d_5K_5 \end{bmatrix} \quad (33a)$$

$${}^0\mathbf{J}_{LL} = \begin{bmatrix} 0 & s_1 & -c_1s_2 & K_2 \\ 0 & -c_1 & -s_1s_2 & K_4 \\ 1 & 0 & c_2 & s_2s_3 \end{bmatrix} \quad (33b)$$

$${}^0\mathbf{J}_{LR} = \begin{bmatrix} -K_A & -K_H & K_N & K_U \\ -K_C & -K_L & K_Q & K_W \\ -K_6 & K_F & K_S & K_Y \end{bmatrix} \quad (33c)$$

The terms K_i from the forward position transformation (eq. (8)) are given in appendix C. The Jacobian matrix ${}^0\mathbf{J}$ is independent of θ_8 . However, if velocities are transformed into {0} from velocities commanded in {8}, θ_8 is involved. Of course, the end-effector Cartesian velocity depends on all joint rates, including $\dot{\theta}_8$.

5.1.2. Jacobian matrix expressed in {4}.

The simplest symbolic form of the ARMII Jacobian matrix is presented in this section. This form is desirable because it reduces computation time for real-time manipulator operations. In addition, closed-form solutions to the inverse Jacobian submatrices are less complicated.

A manipulator Jacobian matrix can be calculated by many methods. The vector cross-product method in reference 11 provides good physical insight into the

problem. With this method, the simplest symbolic form of the Jacobian matrix results when it is based on the middle coordinate frame. When cross products are taken from one end to the other (from {0} to {8} or vice versa), the terms compound greatly. Starting from the middle and working to both ends results in fewer Jacobian matrix terms.

With ${}^0\mathbf{J}$ given by equations (33), the Jacobian matrix referenced to any frame {m} is found and

Cartesian velocities expressed in $\{0\}$ are transformed into $\{m\}$ as follows:

$${}^m\{\dot{X}\} = \left[\begin{array}{c|c} {}^m\mathbf{R} & 0 \\ \hline 0 & {}^m\mathbf{R} \end{array} \right] {}^0\{\dot{X}\} \quad (34)$$

From properties of unitary orthogonal rotation matrices,

$${}^m\mathbf{R} = {}^0\mathbf{R}^{-1} = {}^0\mathbf{R}^T$$

Substituting equation (31) for both ${}^m\{\dot{X}\}$ and ${}^0\{\dot{X}\}$ in equation (34) and using the preceding rotation matrix relationships yield the following equation:

$${}^m\mathbf{J} = \left[\begin{array}{c|c} {}^0\mathbf{R}^T & 0 \\ \hline 0 & {}^m\mathbf{R}^T \end{array} \right] {}^0\{\mathbf{J}\} \quad (35)$$

For the ARMII, $\{4\}$ is the middle coordinate frame. The general form of ${}^4\mathbf{J}$ is reported in equation (36), obtained from $m = 4$ in equation (35):

$${}^4\mathbf{J} = \begin{bmatrix} J_{11} & J_{12} & 0 & J_{14} & 0 & 0 & 0 & 0 \\ J_{21} & J_{22} & 0 & 0 & 0 & 0 & 0 & 0 \\ J_{31} & J_{32} & J_{33} & 0 & 0 & 0 & 0 & 0 \\ J_{41} & J_{42} & J_{43} & 0 & 0 & J_{46} & J_{47} & J_{48} \\ J_{51} & J_{52} & J_{53} & 0 & 1 & 0 & J_{57} & J_{58} \\ J_{61} & J_{62} & 0 & 1 & 0 & J_{66} & J_{67} & J_{68} \end{bmatrix} \quad (36)$$

Equation (9) is a symbolic representation of the matrix ${}^4\mathbf{R}$, and the ${}^4\mathbf{J}$ terms are given in the following equation:

$${}^4\mathbf{J} = \left[\begin{array}{c|c} {}^4\mathbf{J}_{UL} & 0 \\ \hline {}^4\mathbf{J}_{LL} & {}^4\mathbf{J}_{LR} \end{array} \right] \quad (37)$$

where

$${}^4\mathbf{J}_{UL} = \begin{bmatrix} -As_2s_3 & -Ac_3 & 0 & -d_5 \\ d_3s_2s_3s_4 & d_3c_3s_4 & 0 & 0 \\ d_3s_2c_3 + d_5K_5 & -Bs_3 & d_5s_4 & 0 \end{bmatrix}$$

$${}^4\mathbf{J}_{LL} = \begin{bmatrix} K_5 & -s_3c_4 & s_4 & 0 \\ -K_6 & s_3s_4 & c_4 & 0 \\ s_2s_3 & c_3 & 0 & 1 \end{bmatrix}$$

$${}^4\mathbf{J}_{LR} = \begin{bmatrix} 0 & c_5 & s_5c_6 & KK_3 \\ 1 & 0 & -s_6 & c_6c_7 \\ 0 & -s_5 & c_5c_6 & KK_1 \end{bmatrix}$$

$$A = d_3c_4 + d_5$$

$$B = d_3 + d_5c_4$$

When equations (33) and (37) are compared, a great reduction in symbolic terms is evident.

The terms K_i and KK_i from the forward position transformation are given in appendix C. The Jacobian matrix in $\{4\}$ is independent of θ_1 and θ_8 . However, if velocities are transformed into $\{4\}$ from velocities commanded in $\{8\}$, θ_8 is involved; θ_1 is involved when velocities are transformed into $\{4\}$ from velocities commanded in $\{0\}$.

5.1.3. Cartesian velocities expressed in $\{8\}$.

The Jacobian matrix in $\{0\}$ involves fewer symbolic terms than in $\{8\}$. In turn, ${}^4\mathbf{J}$ is significantly simpler than ${}^0\mathbf{J}$. The symbolic form of ${}^8\mathbf{J}$ is not reported. This section uses $\{8\}$ as the coordinate frame to present the necessary transformations for velocity solutions.

The forward velocity problem using ${}^m\mathbf{J}$ yields Cartesian rates expressed in $\{m\}$, where $m = 0$ or 4 in this paper. Equation (34) is used when these rates are desired in $\{8\}$ coordinates to give the following equations:

$$\left. \begin{aligned} \{{}^8\mathbf{v}_8\} &= {}^8\mathbf{R}^T \{{}^m\mathbf{v}_8\} \\ \{{}^8\boldsymbol{\omega}_8\} &= {}^8\mathbf{R}^T \{{}^m\boldsymbol{\omega}_8\} \end{aligned} \right\} \quad (38)$$

The input to the inverse velocity problem is ${}^m\{\dot{X}\}$. When these rates are expressed in $\{8\}$, equations (38) are inverted before ${}^m\mathbf{J}$ is used in the inverse velocity solution as follows:

$$\left. \begin{aligned} \{{}^m\mathbf{v}_8\} &= {}^8\mathbf{R} \{{}^8\mathbf{v}_8\} \\ \{{}^m\boldsymbol{\omega}_8\} &= {}^8\mathbf{R} \{{}^8\boldsymbol{\omega}_8\} \end{aligned} \right\} \quad (39)$$

The rotation matrices ${}^m\mathbf{R}$ are contained in equation (8) for $m = 0$ and equation (9) for $m = 4$.

5.2. Inverse Velocity Kinematics

The inverse velocity problem solves the linear equation (31) for the joint rates when given a Cartesian velocity command. Standard linear solution techniques cannot be used for a redundant manipulator because the Jacobian matrix is nonsquare. The inverse velocity problem for the ARMII is underconstrained with six equations in eight unknowns. Equation (31) can be inverted with the well-known generalized inverse (ref. 13) of the Jacobian matrix. This redundant solution minimizes the Euclidean norm of the joint rates.

General redundancy resolution techniques are not presented in this paper. Instead, two joint rates are specified to solve the inverse velocity problem. The remaining system is six equations in six unknowns. A unique solution exists, when the manipulator is in a nonsingular configuration, i.e., when the Jacobian matrix has full rank. A square set of linear equations results only when one joint rate is specified from the arm joints and one from the wrist joints. This behavior agrees with the inverse position behavior. Specifying two wrist rates is possible, but it leads to an underconstrained set of equations for the arm joint rates, and these equations are beyond the scope of this paper. Additionally, joint rate $\dot{\theta}_4$ cannot be specified independently of the translational velocity command because of the structure of the ARMII. The length of reach from the shoulder to the wrist determines the elbow joint angle θ_4 . A derivative of this constraint dictates that the elbow joint rate $\dot{\theta}_4$ is uniquely determined by the Cartesian translational velocity command.

5.2.1. Independent solution for $\dot{\theta}_4$. The joint rate $\dot{\theta}_4$ is solved independently of the remaining seven unknown joint rates from a time derivative of equation (12). Equation (11) is rewritten as

$$P_X^2 + P_Y^2 + P_Z^2 = d_3^2 + d_5^2 + 2d_3d_5c_4 \quad (40)$$

Simplifying the time derivative of equation (40) yields the following solution for $\dot{\theta}_4$:

$$\dot{\theta}_4 = \frac{-(P_X^0 \dot{x} + P_Y^0 \dot{y} + P_Z^0 \dot{z})}{d_3 d_5 s_4} \quad (41a)$$

In equation (41a), the Cartesian velocity command is expressed in $\{0\}$. When the frame of expression is $\{4\}$, $\dot{\theta}_4$ is simplified as shown in the following equation:

$$\dot{\theta}_4 = \frac{-1}{d_5} \left[{}^4\dot{x} + \frac{A}{d_3 s_4} {}^4\dot{y} \right] \quad (41b)$$

where A is defined following equation (37).

5.2.2. Inverse velocity solution for remaining joint rates. The inverse velocity problem exploits decoupling of the position from the orientation. Equation (31) is rewritten as

$$\left[\begin{array}{c|c} {}^m\mathbf{J}_{UL} & 0 \\ \hline {}^m\mathbf{J}_{LL} & {}^m\mathbf{J}_{LR} \end{array} \right] \left\{ \begin{array}{c} \{\dot{\theta}\}_A \\ \{\dot{\theta}\}_W \end{array} \right\} = \left\{ \begin{array}{c} \{^m\mathbf{v}_8\} \\ \{^m\boldsymbol{\omega}_8\} \end{array} \right\} \quad (42)$$

The upper three equations of equation (42) are solved to yield the unknown arm joint rates. Ac-

counting for the arm joint rates, the bottom three equations are then used to find the unknown wrist joint rates. The joint rate $\dot{\theta}_4$ is known from equations (41). Therefore, column four of ${}^m\mathbf{J}_{UL}$ is subtracted from the right-hand side of equation (42), multiplying by $\dot{\theta}_4$. The remaining system is three equations in three unknowns. However, a unique solution to this system does not exist because it is always singular. The first two rows are dependent; the rank is two and not three. Either row one or two must be removed from the upper system of equations. The remaining system is two equations in three unknowns, as for the arm angles in the inverse position solution. In this paper, the solution is achieved by specifying one joint rate from $\dot{\theta}_1$, $\dot{\theta}_2$, and $\dot{\theta}_3$ and then solving for the other two. The wrist joint rates are solved with the three equations in four unknowns from the bottom of equation (42), after the arm joint rates are obtained. One joint rate from $\dot{\theta}_5$, $\dot{\theta}_6$, $\dot{\theta}_7$, and $\dot{\theta}_8$ is specified and the remaining three are solved from the full-rank system, provided that the wrist is not in a singular configuration.

Solution in frame $\{0\}$ is obtained as follows. If $\dot{\theta}_i$ from the arm joints and $\dot{\theta}_j$ from the wrist are specified, columns i and j are removed from \mathbf{J}_{ULA} and \mathbf{J}_{LR} . Joint rate $\dot{\theta}_i$ is likewise removed from $\{\dot{\theta}\}_{A4}$, and $\dot{\theta}_j$ is removed from $\{\dot{\theta}\}_W$. In addition, to achieve a consistent set of equations for the arm joint unknowns, row 1 of \mathbf{J}_{ULA} is removed; row 1 of the Jacobian matrix in $\{0\}$ or $\{4\}$ is symbolically more complex than row 2. For $m = 0$, the solution is obtained with any linear solution method used for the following equations:

$${}^0\mathbf{J}_{ULi4}\{\dot{\theta}\}_{Ai4} = \{^0\mathbf{v}_8\} - \dot{\theta}_i {}^0\{J_{ULi}\} - \dot{\theta}_4 {}^0\{J_{UL4}\} \quad (43a)$$

$${}^0\mathbf{J}_{LRj}\{\dot{\theta}\}_{Wj} = \{^0\boldsymbol{\omega}_8\} - \dot{\theta}_j {}^0\{J_{LRj}\} - {}^0\mathbf{J}_{LL}\{\dot{\theta}\}_A \quad (43b)$$

The order of equation (43a) is 2×2 . Row 1 of $\{^0\mathbf{v}_8\}$ is removed because the first equation of equation (42) is removed. The order of equation (43b) is 3×3 because the wrist equations are of full rank for the general case.

Solution in frame $\{4\}$ is obtained as follows. The symbolic form of ${}^4\mathbf{J}$ is simpler than ${}^0\mathbf{J}$, as demonstrated in section 5.1.2. When $\{4\}$ is used as the reference frame, the linear equations are solved in closed form. The resolved motion rate solution for this case is given by the following equations:

$$\{\dot{\theta}\}_{Ai4} = {}^4\mathbf{J}_{ULi4}^{-1} (\{^4\mathbf{v}_8\} - \dot{\theta}_i {}^4\{J_{ULi}\} - \dot{\theta}_4 {}^4\{J_{UL4}\}) \quad (44a)$$

$$\{\dot{\theta}\}_{Wj} = {}^4\mathbf{J}_{LRj}^{-1} (\{^4\boldsymbol{\omega}_8\} - \dot{\theta}_j {}^4\{J_{LRj}\} - {}^4\mathbf{J}_{LL}\{\dot{\theta}\}_A) \quad (44b)$$

Row 1 is removed from $\{^4\mathbf{v}_8\}$ in equation (44a). The symbolic terms for the inverse reduced Jacobian submatrices are given in appendix E, for $i = 1, 2, 3$ and $j = 1, 2, 3, 4$.

For either inverse velocity solution (eqs. (43) or (44)), the commanded Cartesian velocities must be transformed into $\{0\}$ or $\{4\}$ coordinates, unless they are specified in these frames. When Cartesian velocities are expressed in $\{8\}$, this transformation is accomplished with equations (39).

6. Manipulator Singularities

At a singular position, a manipulator loses one or more degrees of freedom. A near singular configuration mathematically requires infinite joint rates for certain finite Cartesian velocity commands. Singularity configurations for nonredundant manipulators are determined by equating the Jacobian matrix determinant to 0. For redundant manipulators, the Jacobian matrix is nonsquare and thus its determinant does not exist.

The least-squares redundant solution to the inverse velocity, or resolved motion rate problem, is obtained by inverting equation (31).

$$\{\dot{\theta}\} = {}^m\mathbf{J}^* {}^m\{\dot{X}\} \quad (45)$$

In equation (45),

$$\mathbf{J}^* = \mathbf{J}^T(\mathbf{J}\mathbf{J}^T)^{-1} \quad (46)$$

is the well-known pseudoinverse, or Moore-Penrose inverse of the Jacobian matrix (ref. 5). The singularities for a redundant manipulator can be found by setting the determinant of $(\mathbf{J}\mathbf{J}^T)$ equal to 0, as evident in equation (46). General redundant solutions and singularities, however, are beyond the scope of this paper.

The singularities reported in this section correspond to the inverse velocity solutions presented in section 5.2. Singularities are divided into arm singularities and wrist singularities for manipulators with spherical wrists. For the ARMII, arm singularities are identified from $|{}^m\mathbf{J}_{UL}|$ and wrist singularities from $|{}^m\mathbf{J}_{LR}|$. The order of the reduced Jacobian submatrices used in section 5.2 is 2×3 and 3×4 . When column 4 is removed from ${}^m\mathbf{J}_{UL}$ the determinant is 0 for any manipulator configuration. Thus, joint angle θ_4 and joint rate $\dot{\theta}_4$ cannot be specified in the inverse position and velocity solutions. From equation (41a) or (41b), the joint rate $\dot{\theta}_4$ is infinite when $\theta_4 = 0, \pi$. This characteristic is a singularity condition for all arm joints, as shown in table 10.

Table 10. Arm Joint Singularities

i	$ {}^m\mathbf{J}_{ULi} $	Singularity conditions
1	$d_3d_5c_3s_4^2$	$\theta_3 = \pm \frac{\pi}{2}$ $\theta_4 = 0, \pi$
2	$d_3d_5s_2s_3s_4^2$	$\theta_2 = 0, \pi$ $\theta_3 = 0, \pi$ $\theta_4 = 0, \pi$
3	$-d_3s_4K_Z$	$\theta_4 = 0, \pi$ $K_Z = 0$

To find the arm joint singularity conditions, columns $i = 1, 2,$ and 3 are removed individually from ${}^m\mathbf{J}_{ULi4}$ and the remaining 2×2 determinants are set to 0. Similarly, columns $j = 1, 2, 3,$ and 4 are removed from ${}^m\mathbf{J}_{LRj}$; the 3×3 determinants are equated to 0 to yield the wrist joint singularities.

Given a specific Jacobian matrix, such as ${}^0\mathbf{J}$, the Jacobian matrix referenced to any other frame m is found with equation (35). The singularity conditions are identical for Jacobian submatrices expressed in any coordinate frame because the determinant of a matrix is invariant under rotation transformations. In this paper, ${}^0\mathbf{J}$ and ${}^4\mathbf{J}$ are presented (eqs. (33) and (37)). The submatrices of either Jacobian matrix yield the arm joint singularities in table 10 and the wrist joint singularities in table 11. The condition $K_Z = 0$ under $i = 3$ in table 10 is equivalent to $d_3 = -d_5 \left(c_4 + \frac{c_3s_4}{t_2} \right)$.

Table 11. Wrist Joint Singularities

j	$ {}^m\mathbf{J}_{LRj} $	Singularity conditions
1	$-c_7$	$\theta_7 = \pm \frac{\pi}{2}$
2	$-c_6s_7$	$\theta_6 = \pm \frac{\pi}{2}$ $\theta_7 = 0, \pi$
3	$-s_6c_7$	$\theta_6 = 0, \pi$ $\theta_7 = \pm \frac{\pi}{2}$
4	$-c_6$	$\theta_6 = \pm \frac{\pi}{2}$

The results of tables 10 and 11 are also singularities for the inverse position solutions presented in section 4.2. This section has identified the ARMII

singularities associated with specifying one arm joint rate (excluding the elbow) and one wrist joint rate and solving the inverse velocity problem. Alternate solutions for the neighborhood of singularities are not presented. An alternative is to use the generalized inverse (ref. 5) of the reduced 6×6 Jacobian matrix at or near singularities. At a singularity, the rank of this matrix is less than 6. The determinant is calculated at each calculation step. If it is near 0, the generalized inverse of the reduced Jacobian matrix is used to avoid infinite joint rates. This singularity solution does not track the given velocity command precisely, but it does move the manipulator out of the singularity region so that the solution given in this paper can be used again.

7. Examples

Examples are presented in this section for forward position, inverse position, forward velocity, and inverse velocity problems to demonstrate the equations in this paper. The units are millimeters, degrees, millimeters per second, and radians per second for length, angle, translational velocity, and rotational velocity, respectively. The fixed manipulator lengths for the examples are as follows:

$$\begin{aligned} L_1 &= 500.0 \\ d_3 &= 762.0 \\ d_5 &= 495.3 \\ L_8 &= 470.0 \end{aligned}$$

7.1. Position Kinematic Examples

7.1.1. Forward position transformation.

Two examples for the forward position transformation are given. The first is the initial position shown in figure 3 and the second is a general configuration. For each example, the partitioned solution (eq. (9a)), the transformation from wrist to shoulder (eq. (8)), and the transformation from end effector to base (modified eq. (1)) are given.

Example 1. $\{\theta\} = \{0.0, 0.0, 0.0, 0.0, 0.0, 0.0, 0.0, 0.0\}^T$

$${}^0_4\mathbf{T} = \begin{bmatrix} 1.000 & 0.000 & 0.000 & 0.000 \\ 0.000 & 0.000 & -1.000 & 0.000 \\ 0.000 & 1.000 & 0.000 & 762.000 \\ 0 & 0 & 0 & 1 \end{bmatrix}$$

$${}^4_8\mathbf{T} = \begin{bmatrix} -1.000 & 0.000 & 0.000 & 0 \\ 0.000 & 0.000 & 1.000 & 495.3 \\ 0.000 & 1.000 & 0.000 & 0 \\ 0 & 0 & 0 & 1 \end{bmatrix}$$

$${}^0_8\mathbf{T} = \begin{bmatrix} -1.000 & 0.000 & 0.000 & 0.000 \\ 0.000 & -1.000 & 0.000 & 0.000 \\ 0.000 & 0.000 & 1.000 & 1257.300 \\ 0 & 0 & 0 & 1 \end{bmatrix}$$

$${}^B_H\mathbf{T} = \begin{bmatrix} -1.000 & 0.000 & 0.000 & 0.000 \\ 0.000 & -1.000 & 0.000 & 0.000 \\ 0.000 & 0.000 & 1.000 & 2227.300 \\ 0 & 0 & 0 & 1 \end{bmatrix}$$

Example 2. $\{\theta\} = \{10.0, 20.0, 30.0, 40.0, 50.0, 60.0, -70.0, 80.0\}^T$

$${}^0_4\mathbf{T} = \begin{bmatrix} 0.331 & -0.717 & 0.613 & -256.660 \\ 0.447 & -0.453 & -0.771 & -45.256 \\ 0.831 & 0.529 & 0.171 & 716.046 \\ 0 & 0 & 0 & 1 \end{bmatrix}$$

$${}^4_8\mathbf{T} = \begin{bmatrix} 0.447 & -0.331 & 0.831 & 0 \\ -0.771 & -0.613 & 0.171 & 495.3 \\ 0.453 & -0.717 & -0.529 & 0 \\ 0 & 0 & 0 & 1 \end{bmatrix}$$

$${}^0_8\mathbf{T} = \begin{bmatrix} 0.979 & -0.110 & -0.172 & -611.971 \\ 0.200 & 0.683 & 0.703 & -269.549 \\ 0.041 & -0.722 & 0.690 & 978.284 \\ 0 & 0 & 0 & 1 \end{bmatrix}$$

$${}^B_H\mathbf{T} = \begin{bmatrix} 0.979 & -0.110 & -0.172 & -692.958 \\ 0.200 & 0.683 & 0.703 & 60.660 \\ 0.041 & -0.722 & 0.690 & 1802.788 \\ 0 & 0 & 0 & 1 \end{bmatrix}$$

7.1.2. Inverse position kinematics. The input for this example is ${}^0_8\mathbf{T}$ from example 2 in the previous section. Eight solutions are calculated from the equations in section 4.2. The angles $\theta_1 = 10$ and $\theta_6 = 60$ are specified. Equations (12), (16), (17), (24), (25), and (27) are used for the results of table 12. The methods of sections 4.2.1 and 4.2.2 are used to form the multiple solutions.

Table 12. Inverse Position Kinematic Solutions

n	θ_1	θ_2	θ_3	θ_4	θ_5	θ_6	θ_7	θ_8
1	10	20.00	30.00	40.00	50.00	60	-70.00	80.00
2	10	20.00	30.00	40.00	-164.99	60	70.00	23.04
3	10	47.16	150.00	40.00	341.26	60	-33.24	27.31
4	10	47.16	150.00	40.00	-304.51	60	33.24	-7.81
5	10	47.16	-30.00	-40.00	161.26	60	-33.24	27.31
6	10	47.16	-30.00	-40.00	-124.51	60	33.24	-7.81
7	10	20.00	210.00	-40.00	230.00	60	-70.00	80.00
8	10	20.00	210.00	-40.00	-344.99	60	70.00	23.04

7.2. Velocity Kinematic Examples

The manipulator configuration for the velocity examples is the input to forward position transformation (example 2):

$$\{\theta\} = \{10.0, 20.0, 30.0, 40.0, 50.0, 60.0, -70.0, 80.0\}^T$$

7.2.1. Forward velocity kinematics. Given $\{\theta\}$, ${}^0\mathbf{J}$ is calculated with equations (33), and given $\{\dot{\theta}\}$, the forward velocity solution is calculated with equation (31):

$${}^0\mathbf{J} = \begin{bmatrix} 269.549 & -963.422 & 195.192 & -163.903 & 0 & 0 & 0 & 0 \\ -611.971 & -169.877 & -245.555 & -221.538 & 0 & 0 & 0 & 0 \\ 0 & -649.480 & 54.445 & -411.556 & 0 & 0 & 0 & 0 \\ 0 & 0.174 & -0.337 & 0.613 & -0.717 & -0.257 & 0.945 & -0.172 \\ 0 & -0.985 & -0.059 & -0.771 & -0.453 & 0.878 & 0.316 & 0.703 \\ 1 & 0 & 0.940 & 0.171 & 0.529 & 0.403 & -0.085 & 0.690 \end{bmatrix}$$

$$\{\dot{\theta}\} = \{1.0, 2.0, 3.0, 4.0, 5.0, 6.0, 7.0, 8.0\}^T$$

$$\begin{bmatrix} {}^0\mathbf{v}_8 \\ {}^0\boldsymbol{\omega}_8 \end{bmatrix} = \begin{bmatrix} -1727.3 \\ -2574.5 \\ -2781.8 \end{bmatrix} \quad \begin{bmatrix} {}^0\boldsymbol{\omega}_8 \\ {}^0\mathbf{v}_8 \end{bmatrix} = \begin{bmatrix} 1.90 \\ 5.60 \\ 14.50 \end{bmatrix}$$

The Jacobian matrix relative to $\{4\}$ is calculated with equation (37). The forward velocity solution is calculated with $i = 4$ in equation (31), given the same $\{\dot{\theta}\}$ used previously. The resulting Cartesian velocities still relate $\{8\}$ to $\{0\}$ but are expressed in $\{4\}$:

$${}^4\mathbf{J} = \begin{bmatrix} -184.524 & -934.464 & 0 & -495.300 & 0 & 0 & 0 & 0 \\ 83.761 & 424.183 & 0 & 0 & 0 & 0 & 0 & 0 \\ 637.259 & -570.711 & 318.373 & 0 & 0 & 0 & 0 & 0 \\ 0.831 & -0.383 & 0.643 & 0 & 0 & 0.643 & 0.383 & 0.831 \\ 0.529 & 0.321 & 0.766 & 0 & 1 & 0 & -0.866 & 0.171 \\ 0.171 & 0.866 & 0 & 1 & 0 & -0.766 & 0.321 & -0.529 \end{bmatrix}$$

$$\begin{bmatrix} {}^4\mathbf{v}_8 \\ {}^4\boldsymbol{\omega}_8 \end{bmatrix} = \begin{bmatrix} -4034.6 \\ 932.1 \\ 451.0 \end{bmatrix} \quad \begin{bmatrix} {}^4\boldsymbol{\omega}_8 \\ {}^4\mathbf{v}_8 \end{bmatrix} = \begin{bmatrix} 15.18 \\ 3.78 \\ -0.68 \end{bmatrix}$$

With ${}^0\mathbf{R}$ from the forward position transformation (example 2), ${}^4\{\dot{X}\}$ transforms to the previous ${}^0\{\dot{X}\}$ results and thus proves to be a consistent solution. The solution expressed in $\{8\}$ is calculated with equation (38):

$$\begin{bmatrix} {}^8\mathbf{v}_8 \\ {}^8\boldsymbol{\omega}_8 \end{bmatrix} = \begin{bmatrix} -2319.3 \\ 440.2 \\ -3431.8 \end{bmatrix} \quad \begin{bmatrix} {}^8\boldsymbol{\omega}_8 \\ {}^8\mathbf{v}_8 \end{bmatrix} = \begin{bmatrix} 3.57 \\ -6.85 \\ 13.62 \end{bmatrix}$$

7.2.2. Inverse velocity kinematics. Given $\{\theta\}$ and the forward velocity results expressed in $\{0\}$, the joint rates are calculated with equations (43). In this example, $\dot{\theta}_2 = 2$ and $\dot{\theta}_5 = 5$ are specified. Equation (41a) results in $\dot{\theta}_4 = 4.00$. The terms for equation (43a) are

$${}^0\mathbf{J}_{1UL24} = \begin{bmatrix} -611.971 & -245.555 \\ 0 & 54.445 \end{bmatrix}$$

$${}^0\{\mathbf{J}_{1UL2}\} = \begin{bmatrix} -169.877 \\ -649.480 \end{bmatrix}$$

$${}^0\{J_{1UL4}\} = \begin{Bmatrix} -221.538 \\ -411.556 \end{Bmatrix}$$

The solution for joint rates 1 and 3 is

$$\{\dot{\theta}\}_{A24} = \begin{Bmatrix} 1.00 \\ 3.00 \end{Bmatrix}$$

The terms for equation (43b) are

$${}^0J_{LR1} = \begin{bmatrix} -0.257 & 0.945 & -0.172 \\ 0.878 & 0.316 & 0.703 \\ 0.403 & -0.085 & 0.690 \end{bmatrix}$$

$${}^0\{J_{LR1}\} = \begin{Bmatrix} -0.717 \\ -0.453 \\ 0.529 \end{Bmatrix}$$

$${}^0J_{LL} = \begin{bmatrix} 0 & 0.174 & -0.337 & 0.613 \\ 0 & -0.985 & -0.059 & -0.771 \\ 1 & 0 & 0.940 & 0.171 \end{bmatrix}$$

The solution for joint rates 6, 7, and 8 is

$$\{\dot{\theta}\}_{W1} = \begin{Bmatrix} 6.00 \\ 7.00 \\ 8.00 \end{Bmatrix}$$

The same inverse velocity problem is solved in closed form with equations (44), with respect to the elbow coordinate frame {4}. The input is the forward velocity results expressed in {4}; $\dot{\theta}_3 = 3$ and $\dot{\theta}_8 = 8$ are specified. Equation (41b) yields $\dot{\theta}_4 = 4.00$. The terms for equation (44a) are

$${}^4J_{1UL34}^{-1} = \begin{bmatrix} 0.0018 & 0.0013 \\ 0.0020 & -0.0003 \end{bmatrix}$$

$${}^4\{J_{1UL3}\} = \begin{Bmatrix} 0 \\ 318.373 \end{Bmatrix}$$

$${}^4\{J_{1UL4}\} = \begin{Bmatrix} 0 \\ 0 \end{Bmatrix}$$

The solution for joint rates 1 and 2 is

$$\{\dot{\theta}\}_{A34} = \begin{Bmatrix} 1.00 \\ 2.00 \end{Bmatrix}$$

The terms for equation (44b) are

$${}^4J_{LR4}^{-1} = \begin{bmatrix} 1.3268 & 1 & 1.1133 \\ 0.6428 & 0 & -0.7660 \\ 1.5321 & 0 & 1.2858 \end{bmatrix}$$

$${}^4\{J_{LR4}\} = \begin{Bmatrix} 0.831 \\ 0.171 \\ -0.529 \end{Bmatrix}$$

$${}^4J_{LL} = \begin{bmatrix} 0.831 & -0.383 & 0.643 & 0 \\ 0.529 & 0.321 & 0.766 & 0 \\ 0.171 & 0.866 & 0 & 1 \end{bmatrix}$$

The solution for joint rates 5, 6, and 7 is

$$\{\dot{\theta}\}_{W4} = \begin{Bmatrix} 5.00 \\ 6.00 \\ 7.00 \end{Bmatrix}$$

8. Concluding Remarks

This paper presents the forward position kinematics (given the eight joint angles, how to find the Cartesian position and orientation of the end effector) and forward velocity kinematics (given the eight joint rates, how to find the Cartesian translational and rotational velocities of the end effector) for the redundant eight-degree-of-freedom Advanced Research Manipulator II (ARMII).

Inverse kinematic solutions, required to control the manipulator end effector, are also presented. For a redundant manipulator, the inverse kinematic solutions are not unique because they involve solving for eight unknowns (joint angles for inverse position and joint rates for inverse velocity) in only six equations. The approach in this paper is to specify two of the unknowns and solve for the remaining six unknowns. Two unknowns can be specified with two restrictions. First, the elbow joint angle and rate cannot be specified. The elbow joint angle is determined solely by the commanded end-effector position. Likewise, the elbow joint rate is determined by the commanded end-effector Cartesian translational velocity. Second, one unknown must be specified from the four-jointed wrist, while the second unknown must be specified from one of the arm joints (elbow joint excluded) that translate the wrist.

In the inverse position solution, each set of two specified joint angles has eight sets of solutions. No alternate inverse position solutions are presented for singular configurations. In the inverse velocity problem, with two specified joint rates, the solution is unique, provided that the Jacobian matrix is not singular. A discussion of singularities is based on specifying two joint rates and analyzing the reduced Jacobian matrix. When the reduced Jacobian matrix is singular, the generalized inverse can be used to move the manipulator away from the singularity neighborhood.

With two redundant joints, the methods of this paper allow considerable freedom in solving the inverse kinematic problems. Either joint angles or rates must be specified for one of the three arm joints and one of the four wrist joints at each calculation

step. Control strategies will be developed as actual ARMII hardware experience is accumulated. A simple method for control would be to lock two joints for all motion, for example, joints three and five or joints three and six. To accomplish this method, the locked joint angles and rates would be specified as 0 for all motion. However, the methods of this paper allow more flexibility.

A computer symbolic manipulation program was used with existing standard methods in robotics for

the derivation of the equations. In addition, computer simulations were developed to verify the equations. Examples demonstrate agreement between forward and inverse solutions. Research into applied redundant control strategies is required to realize the potential of the ARMII.

NASA Langley Research Center
Hampton, VA 23681-0001
June 3, 1992

Appendix A

ARMII Nominal Joint Limits

The nominal joint limits for the ARMII are given in table A1. The wrist pitch angle, $i = 7$ in table A1, is severely limited in the positive direction. The wrist roll is continuous and unlimited in both directions, as shown for $i = 8$ in table A1.

Table A1. ARMII Joint Limits

i	θ_i
1	$\pm 165^\circ$
2	$\pm 105^\circ$
3	$\pm 165^\circ$
4	$\pm 105^\circ$
5	$\pm 165^\circ$
6	$\pm 165^\circ$
7	$+22^\circ, -130^\circ$
8	Continuous, bidirectional

Appendix B

Homogeneous Transformation Matrices

Eight homogeneous transformation matrices are given in this appendix, and they relate frame $\{i\}$ to $\{i - 1\}$ for the ARMII, where $i = 1, 2, \dots, 8$. Substituting the Denavit-Hartenberg parameters of table 1 into equation (6) yields these matrices:

$${}^0_1\mathbf{T} = \begin{bmatrix} c_1 & -s_1 & 0 & 0 \\ s_1 & c_1 & 0 & 0 \\ 0 & 0 & 1 & 0 \\ 0 & 0 & 0 & 1 \end{bmatrix}$$

$${}^1_2\mathbf{T} = \begin{bmatrix} c_2 & -s_2 & 0 & 0 \\ 0 & 0 & -1 & 0 \\ s_2 & c_2 & 0 & 0 \\ 0 & 0 & 0 & 1 \end{bmatrix}$$

$${}^2_3\mathbf{T} = \begin{bmatrix} c_3 & -s_3 & 0 & 0 \\ 0 & 0 & 1 & d_3 \\ -s_3 & -c_3 & 0 & 0 \\ 0 & 0 & 0 & 1 \end{bmatrix}$$

$${}^3_4\mathbf{T} = \begin{bmatrix} c_4 & -s_4 & 0 & 0 \\ 0 & 0 & -1 & 0 \\ s_4 & c_4 & 0 & 0 \\ 0 & 0 & 0 & 1 \end{bmatrix}$$

$${}^4_5\mathbf{T} = \begin{bmatrix} s_5 & c_5 & 0 & 0 \\ 0 & 0 & 1 & d_5 \\ c_5 & -s_5 & 0 & 0 \\ 0 & 0 & 0 & 1 \end{bmatrix}$$

$${}^5_6\mathbf{T} = \begin{bmatrix} -s_6 & -c_6 & 0 & 0 \\ 0 & 0 & 1 & 0 \\ -c_6 & s_6 & 0 & 0 \\ 0 & 0 & 0 & 1 \end{bmatrix}$$

$${}^6_7\mathbf{T} = \begin{bmatrix} s_7 & c_7 & 0 & 0 \\ 0 & 0 & -1 & 0 \\ -c_7 & s_7 & 0 & 0 \\ 0 & 0 & 0 & 1 \end{bmatrix}$$

$${}^7_8\mathbf{T} = \begin{bmatrix} c_8 & -s_8 & 0 & 0 \\ 0 & 0 & -1 & 0 \\ s_8 & c_8 & 0 & 0 \\ 0 & 0 & 0 & 1 \end{bmatrix}$$

Appendix C

Factored Kinematic Terms

This appendix presents the kinematic terms factored for efficient computation of the forward position transformation matrices and the Jacobian matrices in $\{0\}$ and $\{4\}$. The common terms for equation (8) and equations (33) and (37) are as follows:

$$\begin{aligned}
 K_1 &= -s_1s_3 + c_1c_2c_3 & K_2 &= s_1c_3 + c_1c_2s_3 \\
 K_3 &= c_1s_3 + s_1c_2c_3 & K_4 &= -c_1c_3 + s_1c_2s_3 \\
 K_5 &= c_2s_4 + s_2c_3c_4 & K_6 &= -c_2c_4 + s_2c_3s_4 \\
 K_7 &= s_2c_4 + c_2c_3s_4 & K_A &= K_1s_4 + c_1s_2c_4 \\
 K_B &= K_1c_4 - c_1s_2s_4 & K_C &= K_3s_4 + s_1s_2c_4 \\
 K_D &= K_3c_4 - s_1s_2s_4 & K_E &= K_5s_5 + s_2s_3c_5 \\
 K_F &= K_5c_5 - s_2s_3s_5 & K_G &= K_Bs_5 + K_2c_5 \\
 K_H &= -K_Bc_5 + K_2s_5 & K_J &= K_Ds_5 + K_4c_5 \\
 K_L &= -K_Dc_5 + K_4s_5 & K_M &= K_Gs_6 - K_Ac_6 \\
 K_N &= K_Gc_6 + K_As_6 & K_P &= K_Js_6 - K_Cc_6 \\
 K_Q &= K_Jc_6 + K_Cs_6 & K_R &= K_Es_6 - K_6c_6 \\
 K_S &= K_Ec_6 + K_6s_6 & K_T &= K_Ms_7 - K_Hc_7 \\
 K_U &= K_Mc_7 + K_Hs_7 & K_V &= K_Ps_7 - K_Lc_7 \\
 K_W &= K_Pc_7 + K_Ls_7 & K_X &= K_Rs_7 + K_Fc_7 \\
 K_Y &= K_Rc_7 - K_Fs_7 & K_Z &= d_3s_2 + d_5K_7
 \end{aligned}$$

The terms for equation (9) and equation (37) are as follows:

$$\begin{aligned}
 KK_1 &= s_5s_7 + c_5s_6c_7 \\
 KK_2 &= s_5c_7 - c_5s_6s_7 \\
 KK_3 &= -c_5s_7 + s_5s_6c_7 \\
 KK_4 &= c_5c_7 + s_5s_6s_7 \\
 KK_5 &= -s_6s_8 - c_6s_7c_8 \\
 KK_6 &= -s_6c_8 + c_6s_7s_8
 \end{aligned}$$

Appendix D

Solution of $E \cos \beta + F \sin \beta + G = 0$

The general solution to the following equation is presented in this appendix:

$$E \cos \beta + F \sin \beta + G = 0 \quad (\text{D1})$$

In equation (D1), E , F , and G are constants and β is unknown. The tangent half-angle substitution is used to transform equation (D1) from a transcendental to a polynomial expression:

$$t = \tan \frac{\beta}{2} \quad (\text{D2})$$

$$\cos \beta = \frac{1 - t^2}{1 + t^2} \quad (\text{D3})$$

$$\sin \beta = \frac{2t}{1 + t^2} \quad (\text{D4})$$

Substituting equations (D3) and (D4) into equation (D1) yields the following polynomial equation:

$$(G - E)t^2 + 2Ft + (G + E) = 0 \quad (\text{D5})$$

The equation has two solutions:

$$t_{1,2} = \left[\frac{-F \pm \sqrt{E^2 + F^2 - G^2}}{G - E} \right] \quad (\text{D6})$$

The first-order transcendental equation (eq. (D1)) has been transformed into a second-order polynomial equation (eq. (D5)). The two corresponding values of β are found by inverting equation (D2) and substituting equation (D6). Both results are valid solutions for equation (D1):

$$\beta_{1,2} = 2 \tan^{-1} \left[\frac{-F \pm \sqrt{E^2 + F^2 - G^2}}{G - E} \right] \quad (\text{D7})$$

Because of the multiplying factor of 2 in equation (D7), the quadrant-specific inverse tangent function is not required. The two-quadrant inverse tangent function suffices, unless G equals E .

Appendix E

Inverse Jacobian Submatrices

The symbolic form of ${}^4\mathbf{J}$ requires the least computation for any ARMII ${}^m\mathbf{J}$ matrices, as demonstrated in section 5.1.2. One advantage of ${}^4\mathbf{J}$ is the ability to apply closed-form solutions for the resolved motion rate, or inverse velocity, problem in real-time computation. This appendix presents the inverses of the reduced Jacobian submatrices ${}^4\mathbf{J}_{1ULi4}$, $i = 1, 2, 3$, and ${}^4\mathbf{J}_{LRj}$, $j = 1, 2, 3, 4$, for use in equations (44).

When the joint rate is specified for the first, second, or third arm joint, the following inverse matrices are used. The order of the matrices in equations (E1) through (E3) is 2×2 because the elbow joint rate $\dot{\theta}_4$ is solved (see eq. (41b)) independently of the remaining joint rates. Two of the three translational velocity equations are independent; $i = 1, 2$, or 3 is specified and the other two arm joint rates are solved. The first subscript 1 in the following equations indicates that row 1 was eliminated from equation (42):

$${}^4\mathbf{J}_{1UL14}^{-1} = \begin{bmatrix} \frac{1}{d_3 c_3 s_4} & 0 \\ \frac{B t_3}{d_3 d_5 s_4^2} & \frac{1}{d_5 s_4} \end{bmatrix} \quad (\text{E1})$$

$${}^4\mathbf{J}_{1UL24}^{-1} = \begin{bmatrix} \frac{1}{d_3 s_2 s_3 s_4} & 0 \\ \frac{d_3 s_2 c_3 + d_5 K_5}{d_3 d_5 s_2 s_3 s_4^2} & \frac{1}{d_5 s_4} \end{bmatrix} \quad (\text{E2})$$

$${}^4\mathbf{J}_{1UL34}^{-1} = \begin{bmatrix} \frac{B s_3}{D} & \frac{c_3}{K_Z} \\ \frac{d_3 s_2 c_3 + d_5 K_5}{D} & \frac{s_2 s_3}{K_Z} \end{bmatrix} \quad (\text{E3})$$

where

$$D = d_3 s_4 (B s_2 + d_5 c_2 c_3 s_4)$$

The term B is defined from ${}^4\mathbf{J}$ (eq. (37)):

$$B = d_3 + d_5 c_4$$

The terms K_5 and K_Z are defined in appendix C.

The following inverse matrices are used when the joint rate is specified for the fifth, sixth, seventh, or eighth manipulator joint (corresponding to $j = 1, 2, 3, 4$):

$${}^4\mathbf{J}_{LR1}^{-1} = \frac{1}{c_7} \begin{bmatrix} K K_4 & c_6 s_7 & -K K_2 \\ s_5 c_6 c_7 & -s_6 c_7 & c_5 c_6 c_7 \\ s_5 s_6 & c_6 & c_5 s_6 \end{bmatrix} \quad (\text{E4})$$

$${}^4\mathbf{J}_{LR2}^{-1} = \frac{1}{s_7} \begin{bmatrix} \frac{K K_4}{c_6} & 1 & \frac{-K K_2}{c_6} \\ \frac{K K_1}{c_6} & 0 & \frac{-K K_3}{c_6} \\ -c_5 & 0 & s_5 \end{bmatrix} \quad (\text{E5})$$

$${}^4\mathbf{J}_{LR3}^{-1} = \frac{1}{s_6} \begin{bmatrix} -c_6 s_5 & 1 & -c_5 c_6 \\ \frac{KK_1}{c_7} & 0 & \frac{-KK_3}{c_7} \\ \frac{s_5}{c_7} & 0 & \frac{c_5}{c_7} \end{bmatrix} \quad (\text{E6})$$

$${}^4\mathbf{J}_{LR4}^{-1} = \frac{1}{c_6} \begin{bmatrix} s_5 s_6 & 1 & c_5 s_6 \\ c_5 c_6 & 0 & -s_5 c_6 \\ s_5 & 0 & c_5 \end{bmatrix} \quad (\text{E7})$$

The order of these matrices is 3×3 because the three rotational velocity equations are independent. The terms KK_i are defined in appendix C.

9. References

1. Baker, Daniel R.; and Wampler, Charles W., II: On the Inverse Kinematics of Redundant Manipulators. *Int. J. Robot. Res.*, vol. 7, no. 2, Apr. 1988, pp. 3-21.
2. Colbaugh, R. D.: A Dynamic Approach to Resolving Manipulator Redundancy in Real Time. *Proceedings of the IASTED International Symposium on Robotics and Automation*, M. H. Hamza, ed., ACTA Press, 1987, pp. 100-104.
3. Dubey, R. V.; Euler, J. A.; and Babcock, S. M.: An Efficient Gradient Projection Optimization Scheme for a Seven-Degree-of-Freedom Redundant Robot With Spherical Wrist. *Proceedings 1988 IEEE International Conference on Robotics and Automation*, Volume 1, IEEE Catalog No. 88CH2555-1, Computer Soc. Press, c.1988, pp. 28-36.
4. Kazerounian, Kazem; and Wang, Zhaoyu: Global Versus Local Optimization in Redundancy Resolution of Robotic Manipulators. *Int. J. Robot. Res.*, vol. 7, no. 5, Oct. 1988, pp. 3-12.
5. Klein, Charles A.; and Huang, Ching-Hsiang: Review of Pseudoinverse Control for Use With Kinematically Redundant Manipulators. *IEEE Trans. Syst., Man, & Cybern.*, vol. SMC-13, no. 2, Mar./Apr. 1983, pp. 245-250.
6. Liegeois, Alain: Automatic Supervisory Control of the Configuration and Behavior of Multibody Mechanisms. *IEEE Trans. Syst., Man, & Cybern.*, vol. SMC-7, no. 12, Dec. 1977, pp. 868-871.
7. Nakamura, Yoshihiko; and Hanafusa, Hideo: Optimal Redundancy Control of Robot Manipulators. *Int. J. Robot. Res.*, vol. 6, no. 1, Spring 1987, pp. 32-42.
8. Nenchev, Dragomir N.: Redundancy Resolution Through Local Optimization: A Review. *J. Robot. Syst.*, vol. 6, no. 6, Dec. 1989, pp. 769-798.
9. Craig, John J.: *Introduction to Robotics—Mechanics and Control*, Second ed. Addison-Wesley Publ. Co., 1989.
10. Whitney, Daniel E.: The Mathematics of Coordinated Control of Prosthetic Arms and Manipulators. *Robot Motion: Planning and Control*, Michael Brady, John M. Hollerbach, Timothy L. Johnson, Tomás Lozana-Pérez, and Matthew T. Mason, eds., MIT Press, c.1982, pp. 287-304.
11. Lee, Sukhan: Kinematic Solution for 8-Degree-of-Freedom—AAI Arm. Interoffice Memo. EM 347-90-277, Jet Propulsion Lab., Aug. 8, 1990.
12. Noble, Benjamin; and Daniel, James W.: *Applied Linear Algebra*, Second ed. Prentice-Hall, Inc., 1977.
13. Mabie, Hamilton H.; and Reinholtz, Charles F.: *Mechanisms and Dynamics of Machinery*. John Wiley & Sons, c.1987.

REPORT DOCUMENTATION PAGE			Form Approved OMB No. 0704-0188	
Public reporting burden for this collection of information is estimated to average 1 hour per response, including the time for reviewing instructions, searching existing data sources, gathering and maintaining the data needed, and completing and reviewing the collection of information. Send comments regarding this burden estimate or any other aspect of this collection of information, including suggestions for reducing this burden, to Washington Headquarters Services, Directorate for Information Operations and Reports, 1215 Jefferson Davis Highway, Suite 1204, Arlington, VA 22202-4302, and to the Office of Management and Budget, Paperwork Reduction Project (0704-0188), Washington, DC 20503.				
1. AGENCY USE ONLY (Leave blank)	2. REPORT DATE August 1992	3. REPORT TYPE AND DATES COVERED Technical Memorandum		
4. TITLE AND SUBTITLE Kinematic Equations for Control of the Redundant Eight-Degree-of-Freedom Advanced Research Manipulator II			5. FUNDING NUMBERS WU 590-11-22-01	
6. AUTHOR(S) Robert L. Williams II				
7. PERFORMING ORGANIZATION NAME(S) AND ADDRESS(ES) NASA Langley Research Center Hampton, VA 23681-0001			8. PERFORMING ORGANIZATION REPORT NUMBER L-16944	
9. SPONSORING/MONITORING AGENCY NAME(S) AND ADDRESS(ES) National Aeronautics and Space Administration Washington, DC 20546-0001			10. SPONSORING/MONITORING AGENCY REPORT NUMBER NASA TM-4377	
11. SUPPLEMENTARY NOTES				
12a. DISTRIBUTION/AVAILABILITY STATEMENT Unclassified-Unlimited Subject Category 63			12b. DISTRIBUTION CODE	
13. ABSTRACT (Maximum 200 words) This paper presents the forward position and velocity kinematics for the redundant eight-degree-of-freedom Advanced Research Manipulator II (ARMII). Inverse position and velocity kinematic solutions are also presented. The approach in this paper is to specify two of the unknowns and solve for the remaining six unknowns. Two unknowns can be specified with two restrictions. First, the elbow joint angle and rate cannot be specified because they are known from the end-effector position and velocity. Second, one unknown must be specified from the four-jointed wrist, and the second from joints that translate the wrist, elbow joint excluded. There are eight solutions to the inverse position problem. The inverse velocity solution is unique, assuming the Jacobian matrix is not singular. A discussion of singularities is based on specifying two joint rates and analyzing the reduced Jacobian matrix. When this matrix is singular, the generalized inverse may be used as an alternate solution. Computer simulations were developed to verify the equations. Examples demonstrate agreement between forward and inverse solutions.				
14. SUBJECT TERMS Manipulator; Redundant; Kinematics; Resolved rate control; Telerobotics			15. NUMBER OF PAGES 26	
			16. PRICE CODE A03	
17. SECURITY CLASSIFICATION OF REPORT Unclassified	18. SECURITY CLASSIFICATION OF THIS PAGE Unclassified	19. SECURITY CLASSIFICATION OF ABSTRACT	20. LIMITATION OF ABSTRACT	