

LV Software for Supersonic Flow Analysis

Final Technical Report
October 1991 to October 1992

for
NASA Grant NAG3-1215
Royce D. Moore, Technical Monitor
Turbomachinery Branch, Mail Stop 776
NASA Lewis Research Center
21000 Brookpark Road
Cleveland, OH 44135

by
Dr. William A. Bell, Project Director
Georgia Tech Research Institute
Signature Technology Laboratory
Atlanta, GA 30332

Contracting through
Georgia Tech Research Corporation
Centennial Research Building
Georgia Institute of Technology
Atlanta, GA 30332

1.0 Introduction - LV software development this past year concentrated on data analysis and presentation

The NASA Lewis Research Center (LeRC) maintains a leadership position in research into advanced aerospace propulsion systems. For the next generation of aircraft, engine designs continue to involve complex, high-speed flows. Performing the detailed flow diagnostics to properly evaluate these designs requires advanced instrumentation to probe these highly turbulent flows. The hostile flow environment often requires nonintrusive measurement techniques such as the laser velocimeter (LV). Since the LV is a proven instrument for nonintrusive flow measurement, it can provide quantitative velocity data with minimal interference to the flow.

However the next generation of aircraft design pushes the limits of present analytical, numerical, and experimental techniques for fluid dynamics. The LV is no exception. To ensure the proper operation of the instrument in diagnosing advanced propulsion systems, the instrument must be configured, calibrated and tested in order to ensure accurate results under flow conditions that are near the limits of operation. The measured velocity data must be rapidly acquired and presented to the operator on-line to that he can respond to changing test conditions. The data must be further processed off line to perform more advanced flow diagnostics such as time series analysis, velocity bias correction, and computation of higher order statistics.

Based on anticipated flow conditions, laser velocimeter systems have been procured from TSI, Inc. The initial system utilized counter processor technology, but later procurements this past year include a more advanced, correlator-based processor, which significantly improves the overall LV performance. To meet the needs of advanced research into propulsion, this instrument must be integrated into an existing VAX/VMS computer system for data acquisition, processing, and presentation.

This report describes the work performed under NASA Grant NAG3-1215 from October 1991 to October 1992. The work done under this grant before this period is described in References 1 and 2 and concentrated on developing the software required to setup and acquire data from the TSI MI-990 multichannel interface, and the RMR 1989 rotating machinery resolver. With the basis established for controlling the operation of the LV system, software development this past year shifted in emphasis from instrumentation control and data acquisition to data analysis and presentation.

Because of the diversity of the type of flows to be investigated, the data analysis includes data importing routines, velocity statistics, time series analysis, and conditional sampling. The remainder of this final technical report describes the objectives, approach, and progress made under NASA Grant NAG3-1215 during 1992. Section 2 presents the overall objectives as well as the specific objectives for 1992. Section 3 describes the approach taken in the LV software development and Section 4 discusses the results.

2.0 Objectives for 1992

The objectives of this grant for 1992 consisted of two tasks.

1. Determine the final LV hardware requirements and the accompanying software needs.
2. Provide software to perform data acquisition, analysis, and presentation of the LV data. This software should provide the overall velocity statistics, conditional sampling, and spectral analysis of the unsteady velocity components.

3.0 Approach

The functions of the software required for this project are to acquire, analyze and present LV velocity data for analysis of advanced engine configurations. The initial LV system consisted of a direct interface to a VAX computer through either a MI-990 interface or a LVABI. The software developed during 1991 under this grant operated the MI-1999 multi-channel interface used to control a 1990C counter processor and a RMR-1989 rotating machinery resolver.

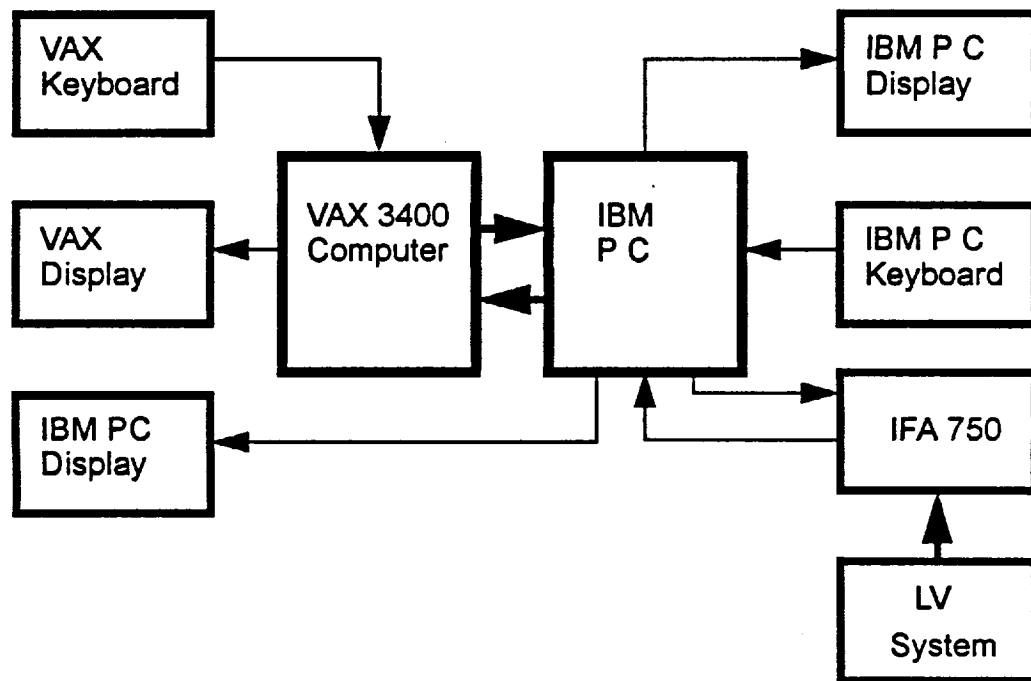

FIGURE 1. System for remote control of the LV system using an IFA 750 counter processor at the NASA Lewis Research Center

3.1 Data Acquisition

During 1992, evaluation of this system by NASA Lewis researchers demonstrated the inability of the counter processor to perform adequately with the signal-to-noise ratios experienced under test conditions. After consultation with TSI, a satisfactory configura-

tion was developed and is shown in Figure 1. The major modifications are the introduction of an IBM-PC computer to control the data acquisition system and replacement of the counter processor with an IFA-750 processor. The IFA 750 model employs a correlator to process the signal from the LV. For low signal-to-noise levels encountered with LV measurements in the flow regimes of interest in advanced engine designs, the correlator performed significantly better than the counter processor and was subsequently selected to process the LV signals. TSI furnished the software to acquire the LV data and perform on-line processing of the velocities, time between samples, and timing synchronization with the RMR rotating machinery resolver.

Since TSI provided the data acquisition software on the IBM PC, the work performed under this grant during 1992 concentrated on off-line data analysis and presentation of the velocity data. The first step involved defining the data format. The data were generated on the IBM PC and transferred to the VAX via magnetic media. TSI plans a future upgrade to the system that includes a direct link between the VAX and IBM PC processors through the existing computer network. The LV data format is shown in Table 1.

TABLE 1. Format of the TSI-LV velocity and encoder data

Sample	Velocity Channel	Velocity $\frac{m}{s}$	Encoder Position $\left(\frac{degrees}{10}\right)$	Cycle Number <i>revolutions</i>	Blade Number	Validation Indicator (1 = valid) (0 = ignore)
Integer	Integer	Real	Integer	Integer	Integer	Real

In the present configuration, there is only one counter. Since the RMR-1989 converts the time between samples to angular position, the time between LV data is not included. However, multiple channels and the time between samples are anticipated as future upgrades. Consequently, the data analysis software developed under this grant is designed to accommodate these upgrades.

3.2 Data Analysis

The LV data analysis software consists of three major components - computing velocity statistics, conditional sampling, and time series analysis. The velocity statistics supported by the software developed under this grant include the mean, turbulence intensity, and histogram. Since the sampling process depends on the particle dynamics, the estimates of the velocity statistics can be biased if the sampling rate and the velocity are correlated. TSI assumes perfect correlation between the sampling and the velocity field and corrects the resulting statistics accordingly. However, Edwards and Meyers show in Ref. 3 that this assumption is generally incorrect and propose an alternative procedure, which is available with the software developed under this grant. The histogram of the velocity is used along with the sampling rate to correct for the bias in the velocity statistics. The software also

integrates the histogram to provide estimates of the skew and kurtosis, if desired. For the flow studies employing conditional sampling and spectral analysis, the need for biasing corrections is questionable. Since the velocity data are grouped into individual time slots and an average obtained for each slot, the fact that there are more samples at higher velocities simply means that there may be more points in that particular slot, but the average velocity is essentially unbiased.

Conditional sampling algorithms have been included in the LV software package and consist of two parts - local averaging and ensemble averaging. The local averaging algorithms are described in Reference 4 and involve synchronizing the sampling process with an external trigger to map a periodic flow field over time. In the present studies, the rotating machinery resolver relates the velocity measurement to an angular position resolved to one-tenth of a degree. The multiple readings at each location are averaged together to obtain the mean V_i and turbulence intensity σ_i at each angle θ_i using the relations given in Table 2. These results are also used to compute the standard deviations of the periodic and random signal components separately.

TABLE 2. Equations used in conditional and ensemble averaging

Variable	Conditional Sampling	Ensemble Averaging
Number of samples $N(\theta_i)$	Number of samples at each encoder position θ_i , where θ_i is in tenths of a degree and varies from 0 to 3600	$\sum_{blades} N(\theta_i), 0 \leq \theta_i \leq \frac{3600}{blades}$
Mean Velocity $\bar{V}(\theta_i)$	$\frac{\sum_i V(\theta_i)}{N(\theta_i)}$	$\frac{\sum_{blades} V(\theta_i)}{\sum_{blades} N(\theta_i)}$
Standard Deviation $\sigma(\theta_i)$	$\sqrt{\frac{\sum_i V^2(\theta_i)}{N(\theta_i)} - \bar{V}_i^2}$	$\sqrt{\frac{\sum_{blades} V^2(\theta_i)}{\sum_{blades} N(\theta_i)} - \bar{V}_i^2}$

The ensemble averaging can be employed whenever multiple periods of the periodic velocity field occur over one cycle of the rotating machinery resolver. This procedure consists of combining the data taken over multiple periods during one revolution to form the average velocity field of one cycle. For instance, consider the velocity field between blades of a rotating turbine. As shown in the next section, the software can provide the fluctuations in velocity over one revolution and can also compute the average intrablade velocity field averaged over all the blades.

The software package provided under this grant is also capable of performing spectral analysis on the data using the methods described in Reference 5. Since the time between samples with the LV is generally nonuniform, which precludes the use of the fast Fourier transform (FFT), the spectral estimates are obtained by first computing estimates of the correlation function. Once obtained, the FFT can be used on the slotted correlation function to obtain the estimate of the power spectrum. The software can provide the correlation function estimate, the variance of the estimate within each lagged time slot, the number of points within each slot, and the frequency spectrum for individual LV channels and channel pairs.

3.3 Data Presentation

As shown in the next section, data presentation of conditional or ensemble averaging consists of three plots. The first is a plot of the number of samples per angular interval, which is at least 0.1 degree. This plot is followed by the angular distribution of the mean velocity. The final plot presents the standard deviation about the local mean versus angular distribution. When combined with the overall velocity statistics, these plots give a quantitative description of the flow field.

The time series analysis software presentation consists of three plots. The first presents the estimates of autocorrelation or cross correlation functions versus lagged time. In addition, the variance in the correlation estimates can be presented along with the number of samples per lagged time slot. Finally, by applying the fast Fourier transform to the correlation estimates, either the auto or cross power spectral density distributions can be obtained and displayed versus frequency.

To generate these plots requires a sophisticated plotting package. Although custom-tailored plotting routines can be written for individual plotting devices and lead to efficient utilization of a particular device, they are not generally applicable to a wide variety of plotters and displays. One of the goals of the present data presentation software is to make the plots available on as many platforms as possible and still retain plotting efficiency as indicated primarily by speed. As a result of investigating the resources available within NASA and Georgia Tech for development of data presentation software, the DISSPLA plotting package supported by Computer Associates was selected.

DISSPLA can be used with almost all currently available plotting and display devices envisioned for use at NASA LeRC. In addition, the plot files can be transferred through the networks to remote sites for presentation to interested parties off-site. For instance, the plots presented in the next section were transferred from NASA LeRC to Georgia Tech through various networks as postscript files that were output on the local Georgia Tech postscript laser printers.

DISSPLA can also be used in conjunction with NASADIG through a procedure that translates the DISSPLA calls into appropriate NASADIG calls. This procedure has been tested using the present data presentation packages, and successful translation resulted. Future upgrades can employ PV-WAVE, which is widely used within NASA and other parts of the scientific community for rapid data display on VAX and SUN workstations.

4.0 Results

During the course of this past year, researchers at NASA Lewis installed, checked out, and applied the TSI IFA 750-based LV system. Data from one of the runs was used to check out the software for computing the velocity statistics and conditional sampling. The RMR 1989 synchronized the sampling process with rotating blades so that the individual and ensemble averaged velocity fields between the blades could be determined.

4.1 Velocity Statistics

ΔV 1.00

AVERAGE 212.04

RUN 8.24

CHANNEL 1

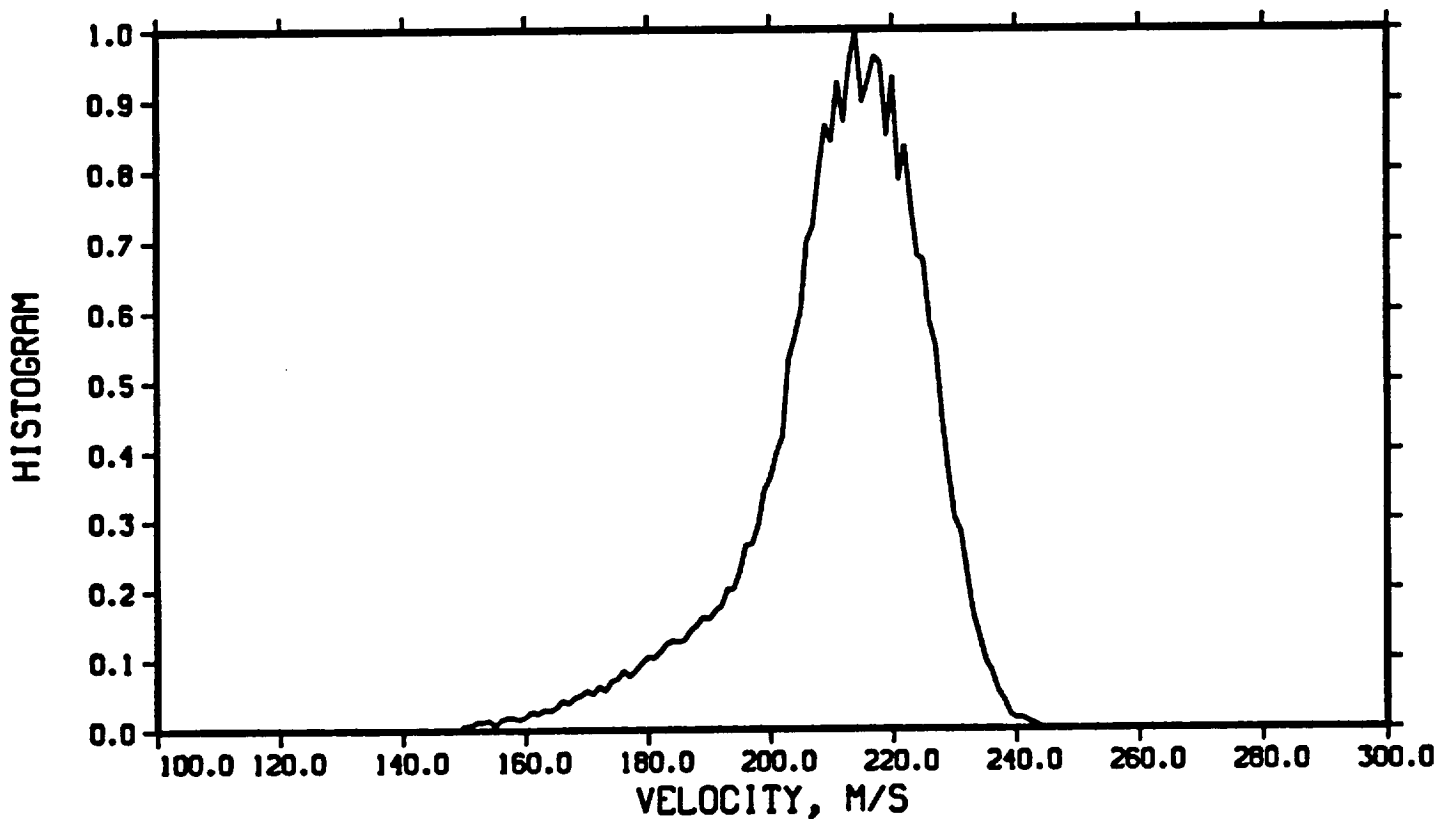

TEST DATA - 08/24/92

FIGURE 2. Overall velocity histogram

Figure 2 shows the histogram of the overall velocity data. This histogram is an example of a skewed distribution in contrast with a profile such as a Gaussian that is symmetric about

the mean value. The average velocity in this case is 212.36 meters/second with a standard deviation of 19.29 meters/second.

This plot was generated using the DISSPLA graphics software available at NASA LeRC. The plotting commands were generated in the postscript graphics language and transferred to a remote, postscript compatible printer at Georgia Tech for hard copy. The data could be displayed at a remote graphics terminal as well using the extensive device support available with DISSPLA.

4.2 Conditional Sampling

```
RUN 8.24
CHANNEL      1
AVERAGE/SLOT 25
MAXIMUM -    104
MINIMUM -     0
* OF SLOTS   3600
```

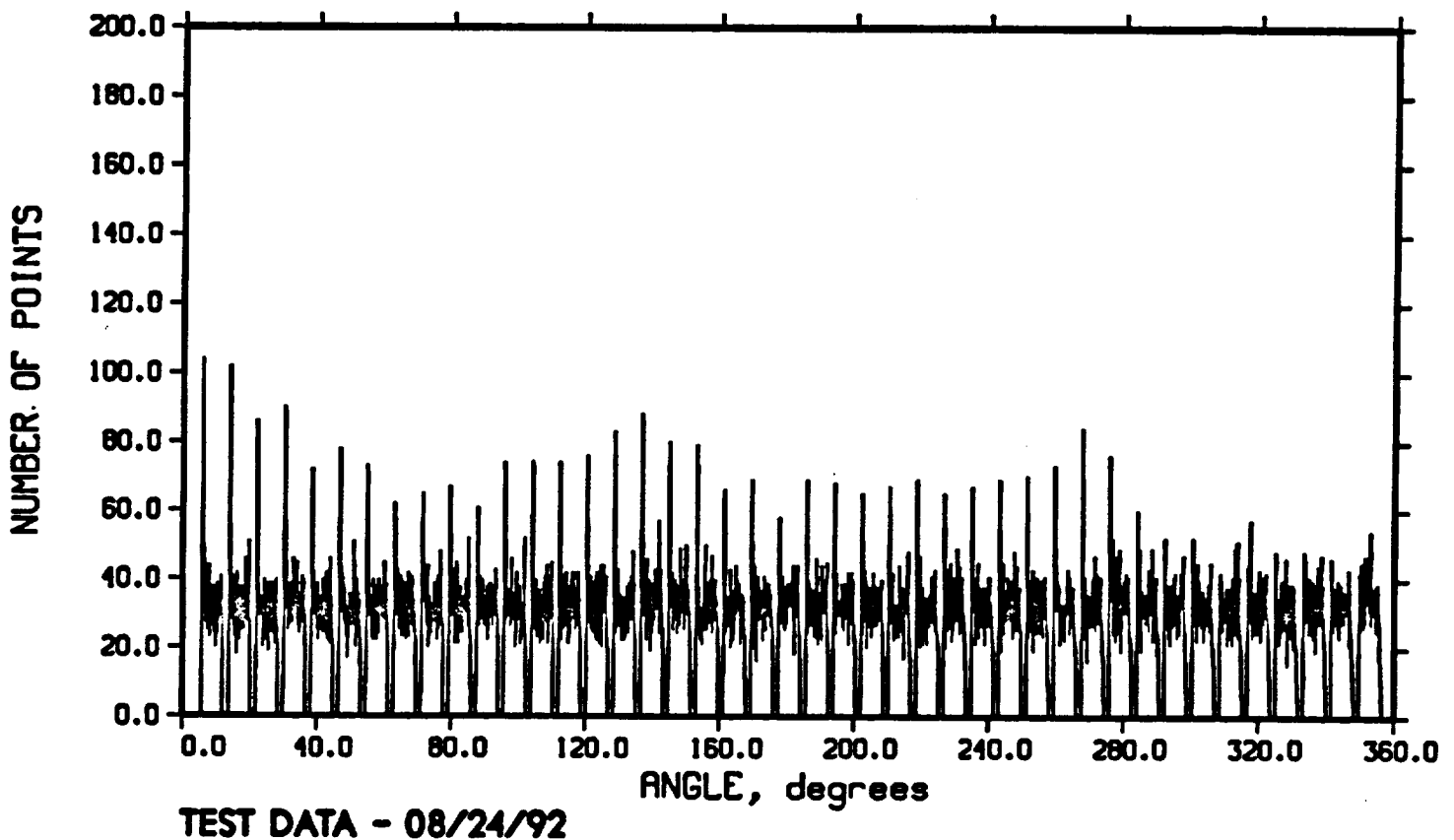

FIGURE 3. Distribution of the number of samples with angle over the run

Whereas Figure 2 presents the overall distribution of samples with respect to velocity amplitude, Figure 3 shows the number of samples taken at each sampling interval of 0.1 degree over a number of revolutions. Most of the sampling intervals contain between 25 and 40 points. However, as the blades pass by the laser beams, there are regions where no data are taken because of interference by the passing blades. The RMR 1989 was programmed to ignore data within the angular intervals occupied by the blades, which resulted in the regions of zero samples. Immediately after these regions, a high number of samples, between 60 and 100, was evident in the data close to the blades.

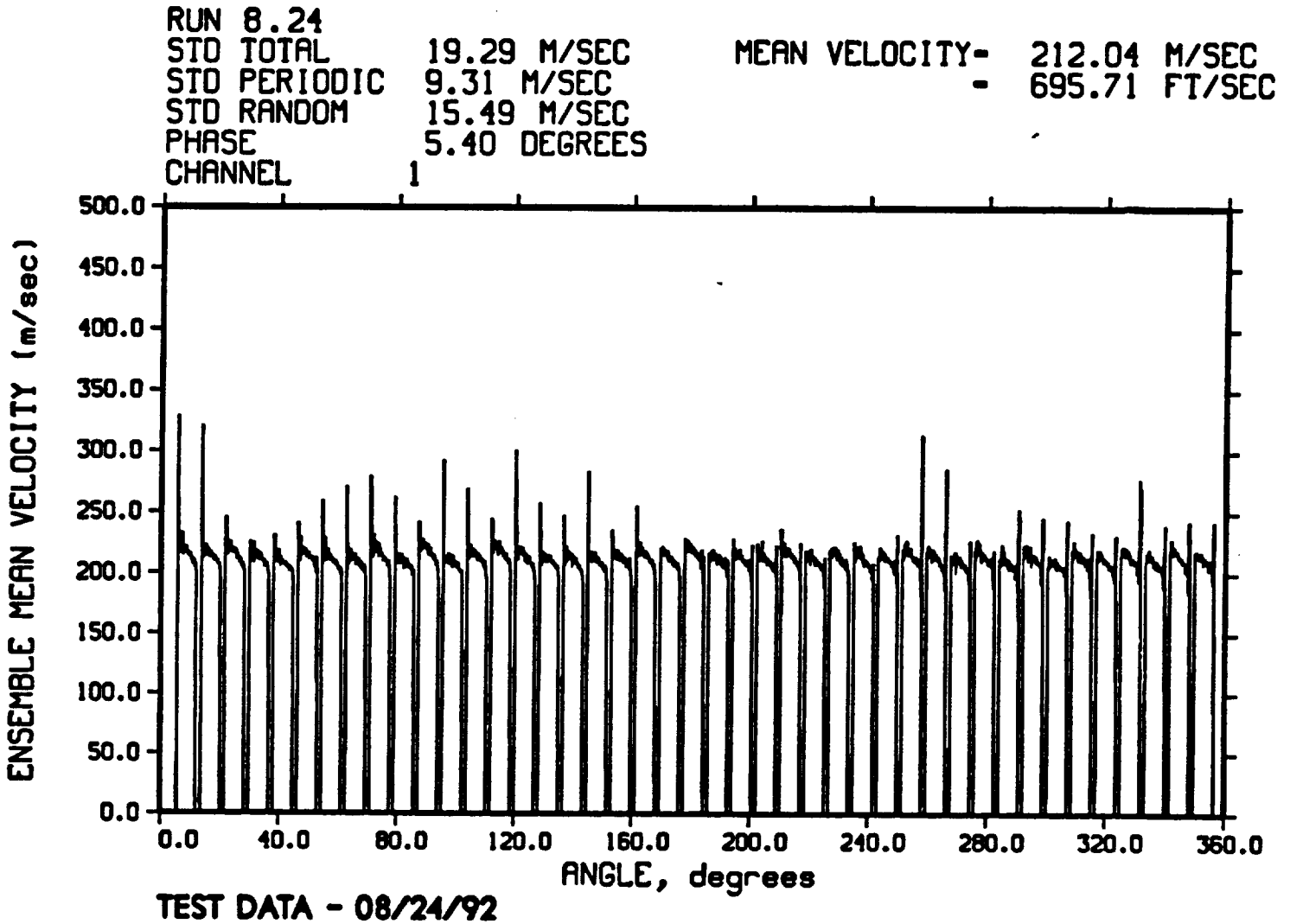

FIGURE 4. Distribution of mean velocity with angle

The regions closest to the blades also exhibit the highest values of mean velocity, as shown in Figure 4, and lie outside the range of velocities between 200 to 225 meters/second char-

acteristic of the majority of angular positions. The regions of zero mean velocity correspond to the regions where no samples were taken because of blockage.

Figure 5 shows the distribution in turbulence intensity with angle, in 0.1-degree sampling intervals. In general, the regions of maximum turbulence intensity occur near the blades. The standard deviation of the periodic velocity fluctuations is given at the top of the figure and was obtained from the variation in the individual means over the 360-degree sampling interval. The standard deviation of the random fluctuations is taken to be the average of the individual standard deviations about the means within each 0.1-degree angular sampling interval.

```

RUN 8.24
STD TOTAL      19.29 M/SEC      MEAN VELOCITY- 212.04 M/SEC
STD PERIODIC   9.31 M/SEC       -             695.71 FT/SEC
STD RANDOM     15.49 M/SEC     TIP VELOCITY - 212.04 M/SEC
PHASE          5.40 DEGREES
CHANNEL        1
    
```

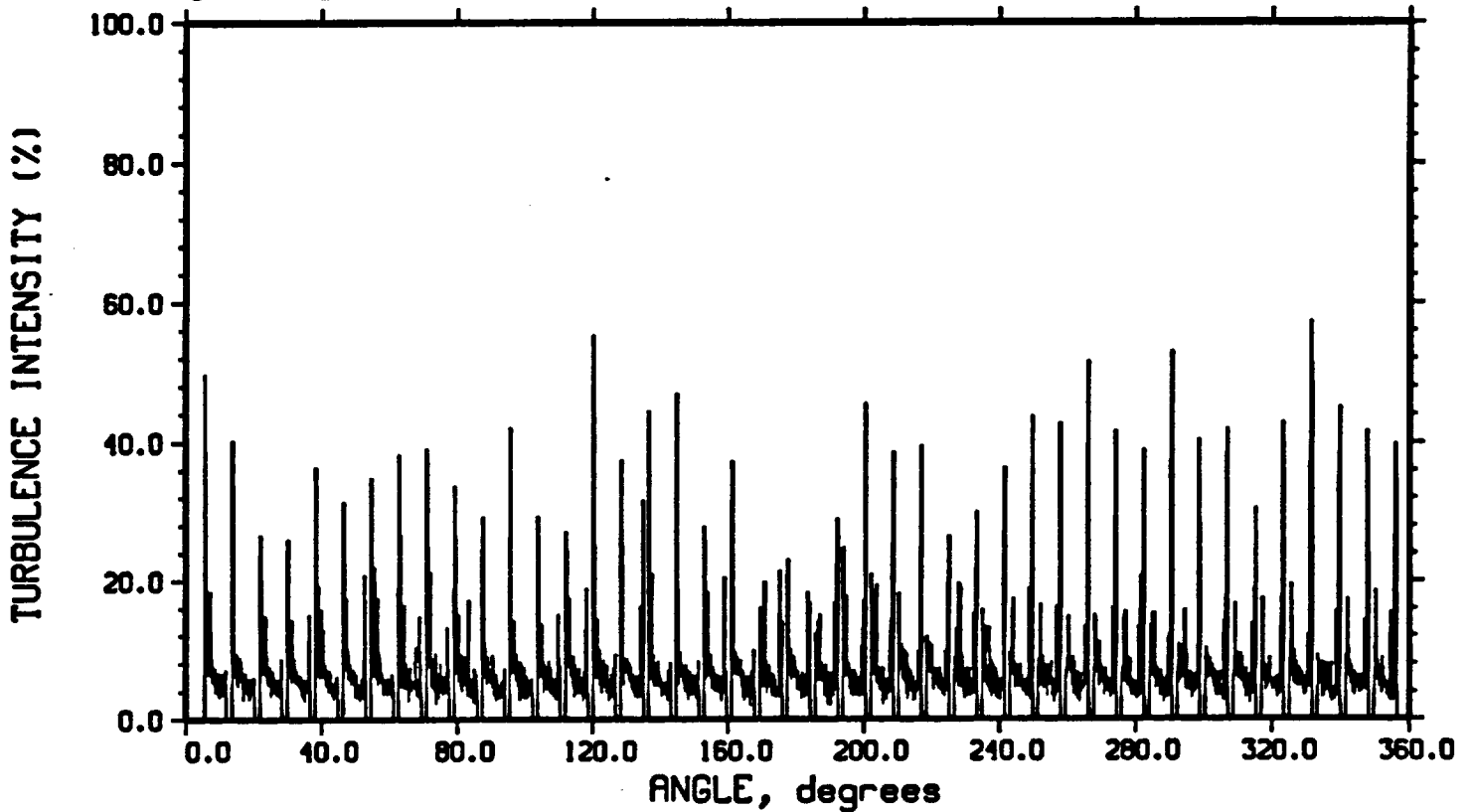

TEST DATA - 08/24/92

FIGURE 5. Distribution in turbulence intensity with angle

The data shown in Figures 3 through 5 were taken over a complete revolution. It was also of interest to take the ensemble average of each blade to arrive at an average flow field between blades. These results consisted of the distributions of samples, means, and turbulence intensity over the angular extent of the region between blades, which is 8.2 degrees for the test reported here. The results are given in Figures 6 through 8.

RUN 8.24
CHANNEL 1

AVERAGE/SLOT 1146
MAXIMUM - 2350
MINIMUM - 0
* OF SLOTS 81

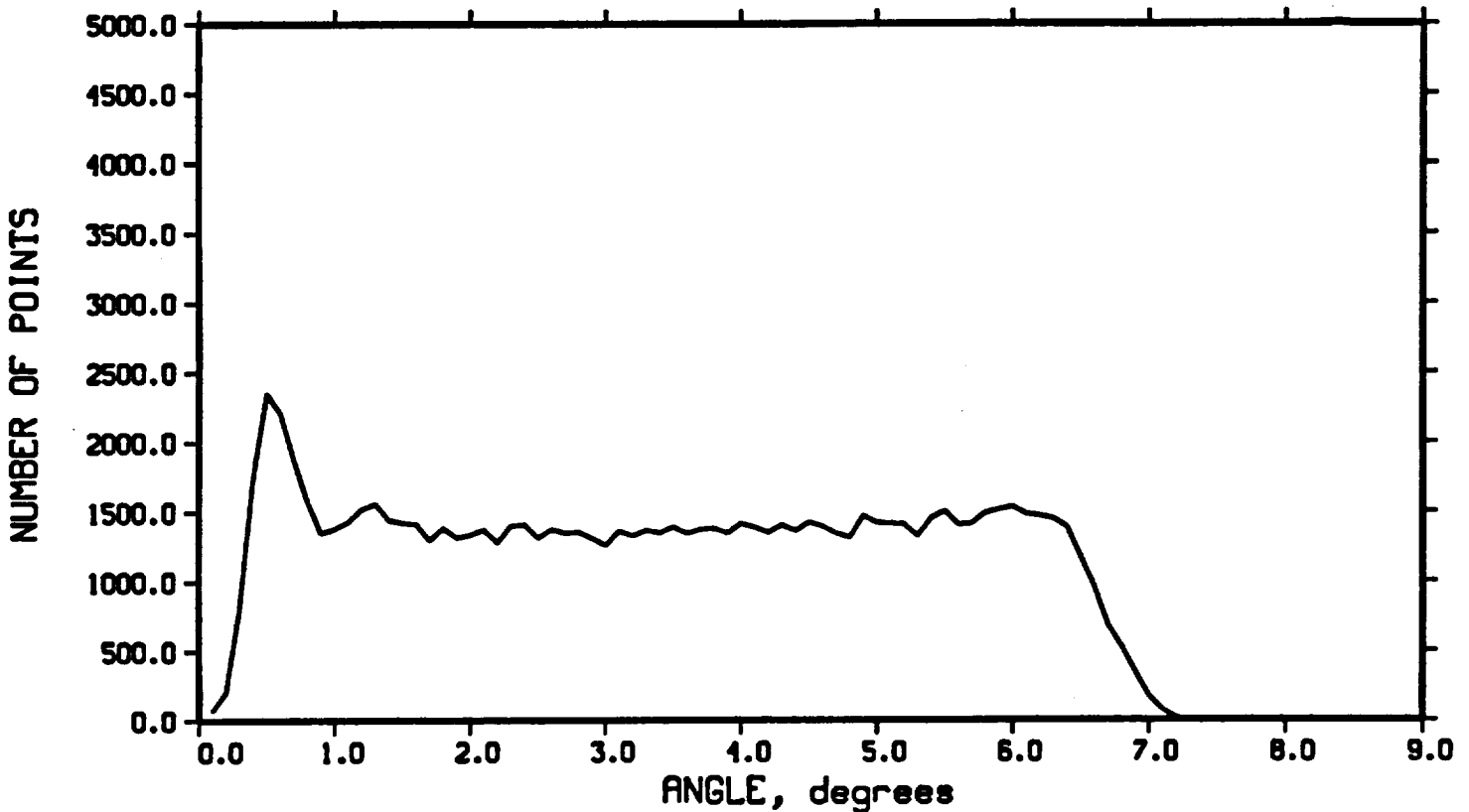

TEST DATA - 08/24/92

FIGURE 6. Combined distribution of samples between blades

Figure 6 shows that the number of samples peaked near the start of the blade passage and was relatively uniform thereafter until the end of the intrablade passage, where the number of samples tapers off to zero.

```

RUN 8.24
STD TOTAL      19.29 M/SEC      MEAN VELOCITY- 212.04 M/SEC
STD PERIODIC   8.22 M/SEC      - 695.71 FT/SEC
STD RANDOM     20.65 M/SEC
PHASE         5.40 DEGREES
CHANNEL       1

```

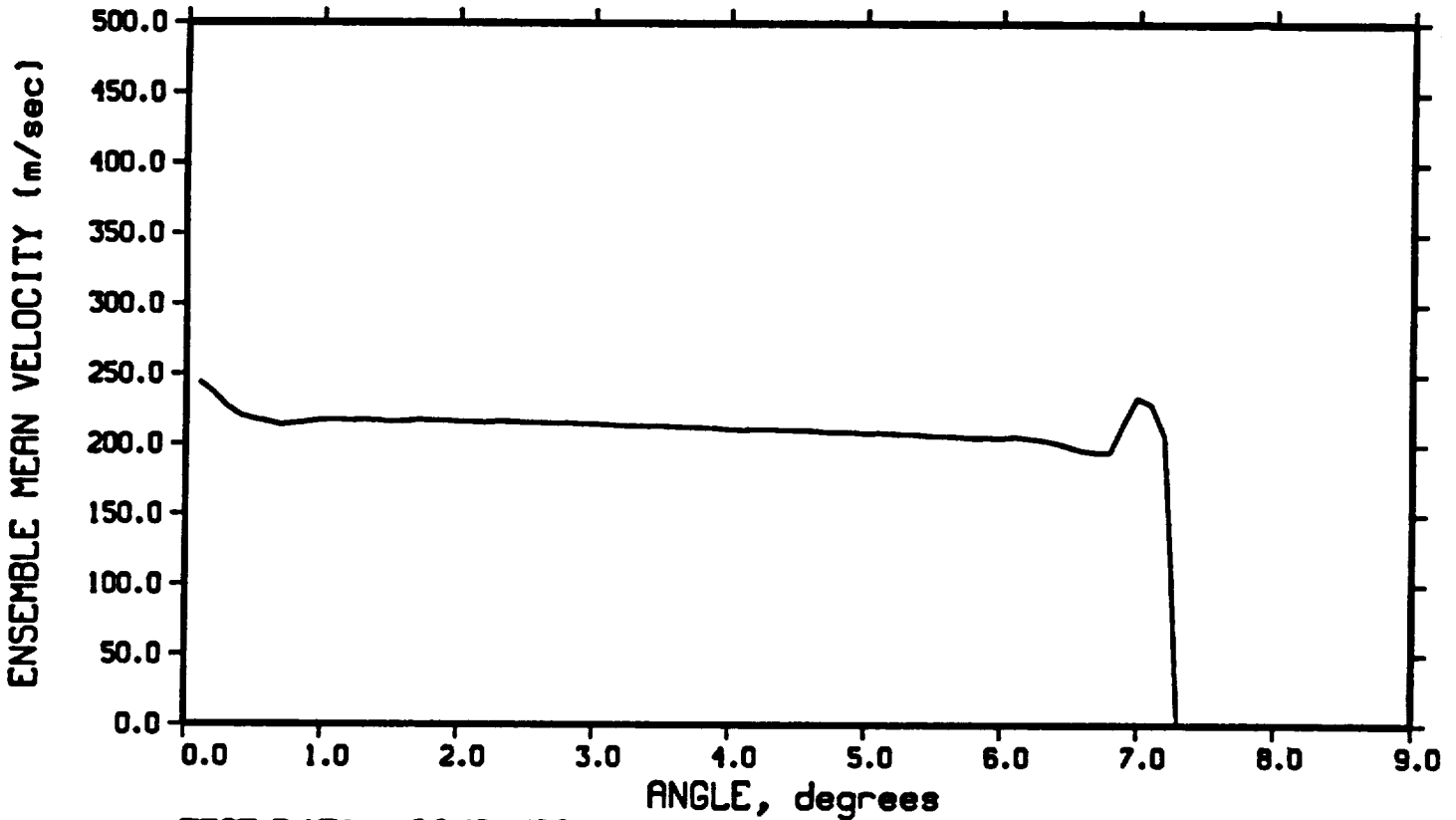

TEST DATA - 08/24/92

FIGURE 7. Combined mean velocity distribution between blades

Figure 7 shows the mean velocity decreases uniformly from 220 m/s at one degree to 200 m/s at 6.5 degrees. Beyond this angular interval close to the blades the velocity peaks to around 240 m/s. A similar trend is shown in the turbulence intensity given in Figure 8.

```

RUN 8.24
STD TOTAL      19.29 M/SEC      MEAN VELOCITY- 212.04 M/SEC
STD PERIODIC   8.22 M/SEC      - 695.71 FT/SEC
STD RANDOM     20.65 M/SEC     TIP VELOCITY - 212.04 M/SEC
PHASE         5.40 DEGREES
CHANNEL       1

```

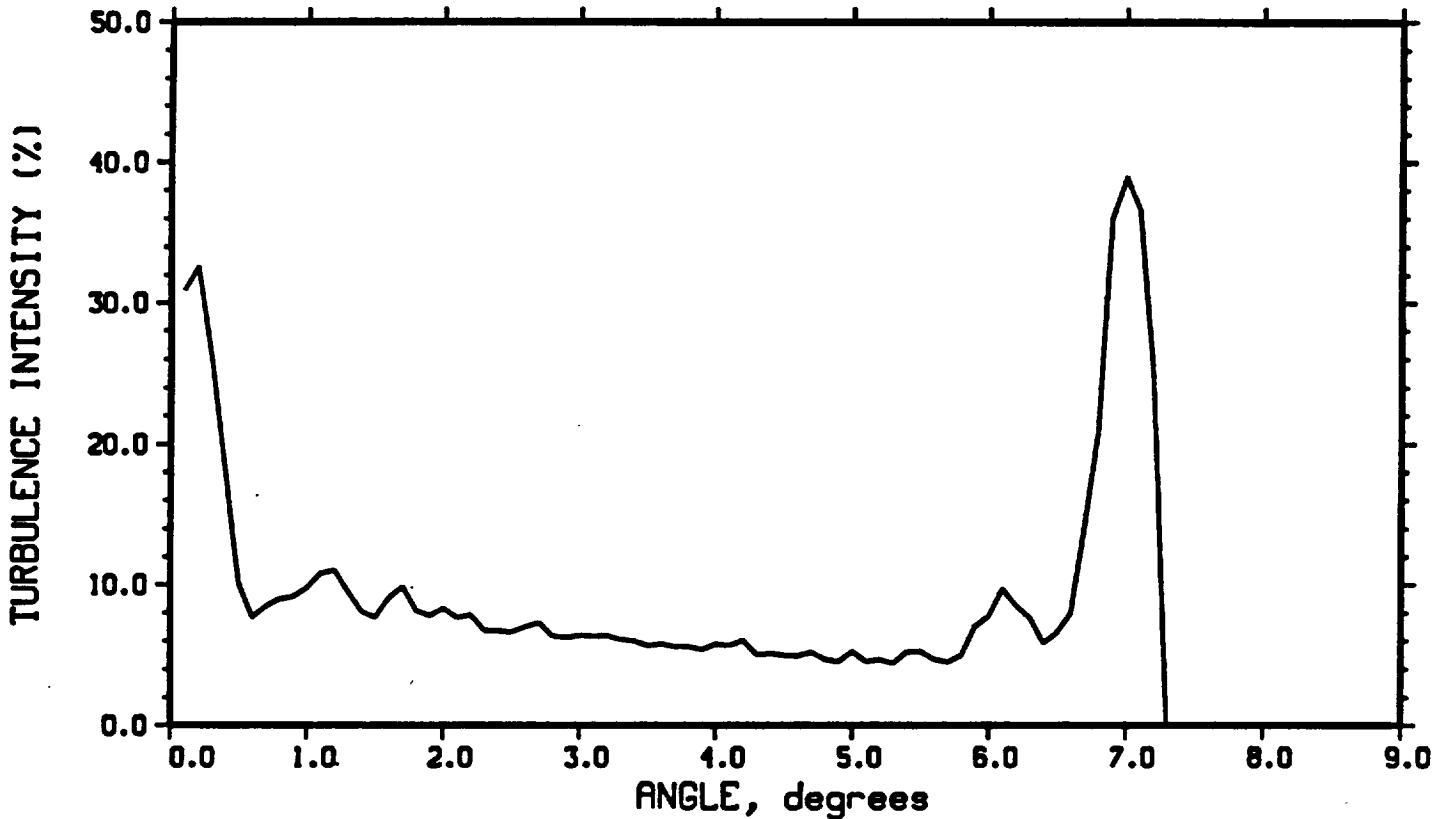

TEST DATA - 08/24/92

FIGURE 8. Combined turbulence intensity in the flow field between blades

Like the mean velocity distribution, the average turbulence intensity decreased uniformly between 1.0 and 5.5 degrees from 8 to 5 m/s, as shown in Figure 8. Unlike the mean, however, the rises in value at the extremities were very pronounced, increasing to between 30 and 40 m/s near the blades.

4.3 Spectral Analysis

Spectral analysis of LV data can be performed using the software developed under this grant, which is based in the techniques described in Reference 5. For the nonuniformly sampled data typical of the LV, a modified Blackman-Tukey algorithm was employed and

was referred to as the slotted correlation method in Reference 5. With this method an estimate of the correlation function was computed first and resulted in a uniformly distributed correlation estimate suitable for use with a fast Fourier transform. An estimate of the correlation function shown in Figure 9 used simulated LV data to check out the software.

ΔT 50.00
STD DEV 18.10

RUN 99.999
CHANNEL 1

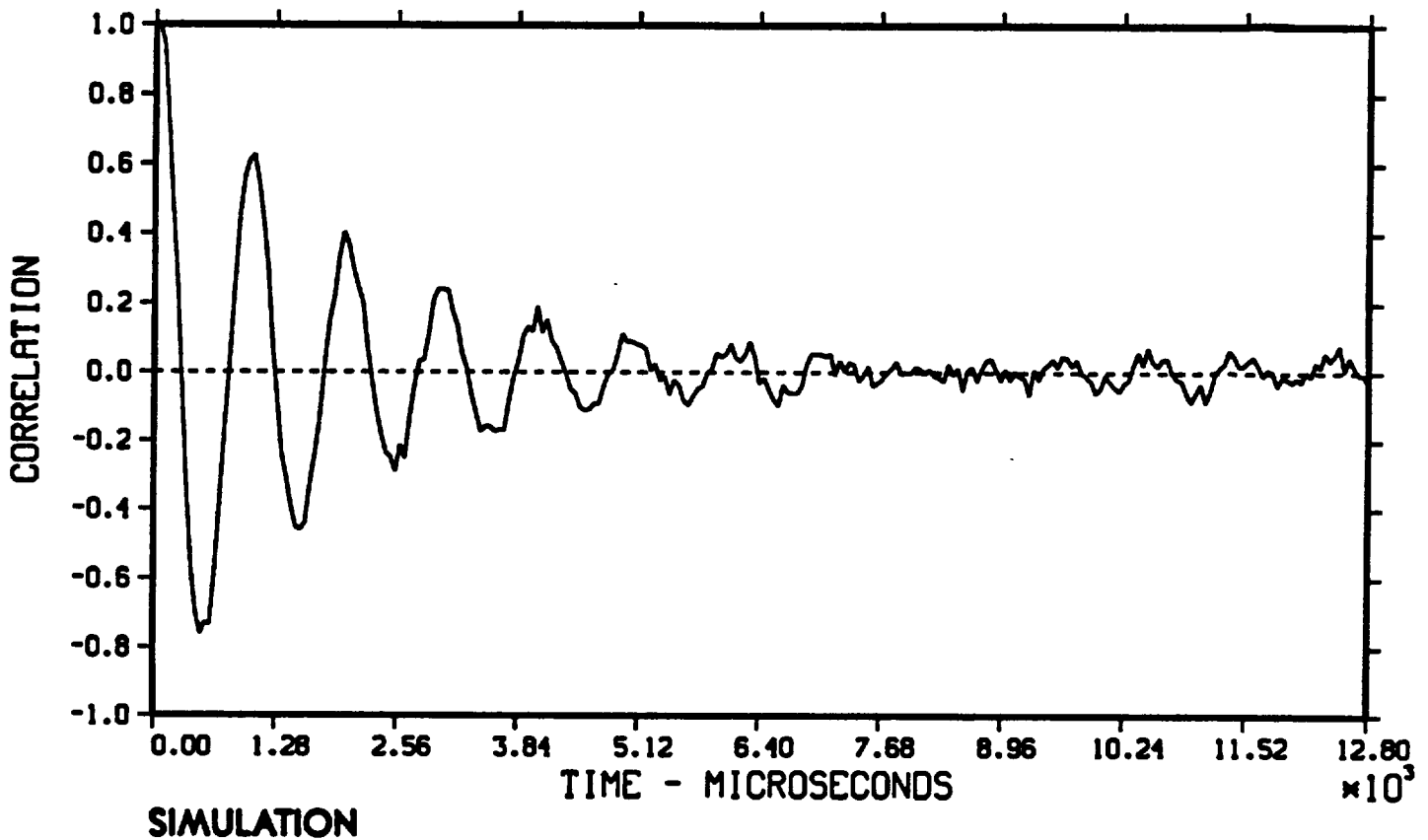

FIGURE 9. Estimate of the correlation function using simulated LV data

Taking the fast Fourier transform of the estimate of the correlation function resulted in the estimate of the power spectral density shown in Figure 10.

ΔF - 39.06 HZ STD DEV- 18.10 FT/SEC

RUN 99.999

ΔT -50 USEC

- 5.52 M/SEC

CHANNEL 1

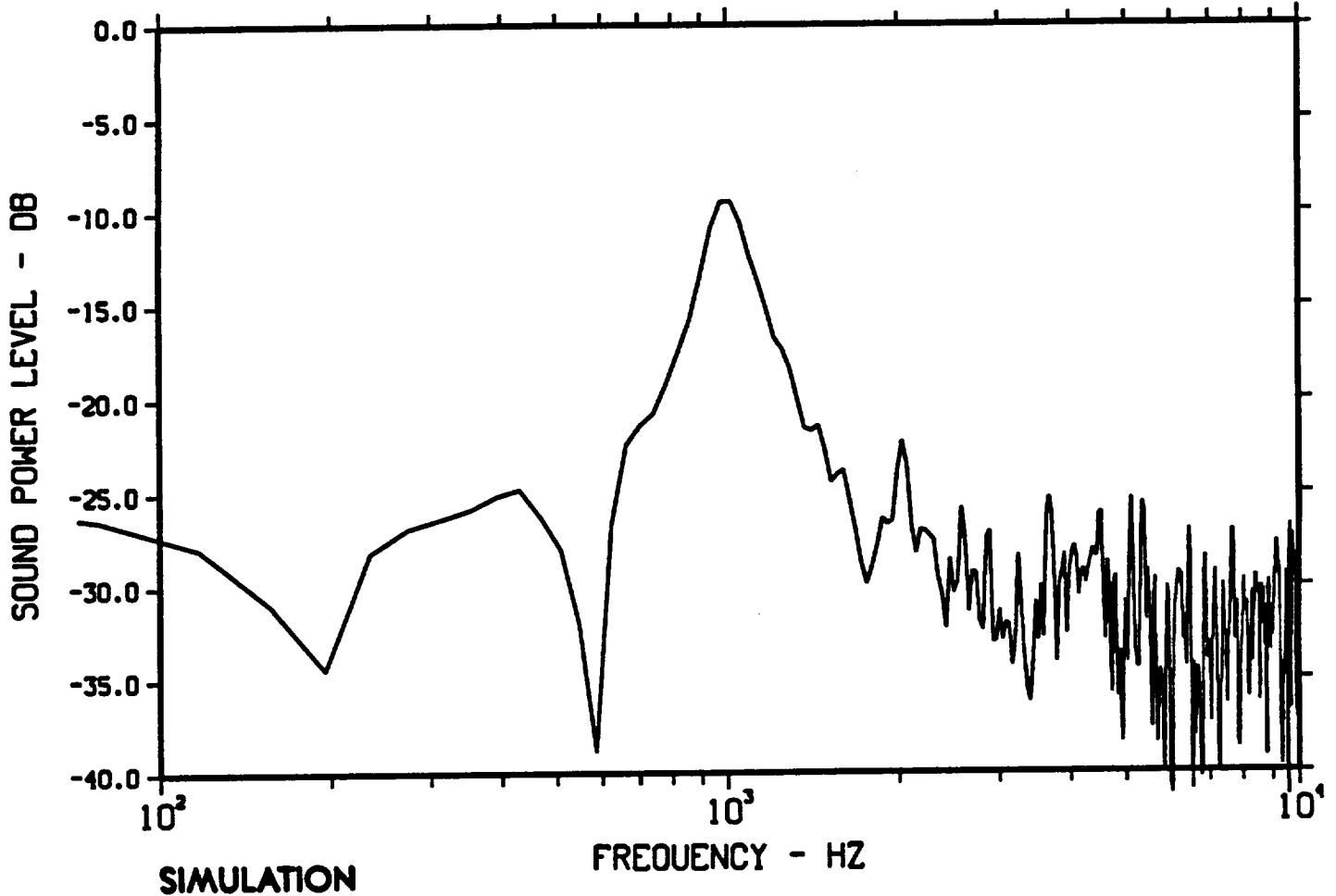

FIGURE 10. Estimate of the power spectral density using simulated LV data

The power spectra has been used to determine the frequency content of the LV data for quantitative flow analysis. The variance of the correlation and power spectra estimates has been shown in Reference 5 to depend on the sampling rate and the number of points per lagged time slot in the correlation function. The sampling rate was determined using plots of the time between samples shown in Figure 11 and number of samples per lagged time slot in the correlation estimate shown in Figure 12. The ability to plot these important variables, from which the sampling rate can be determined, is included in the software.

ΔT 50.00
STD DEV 0.00

RUN 99.999
CHANNEL 0

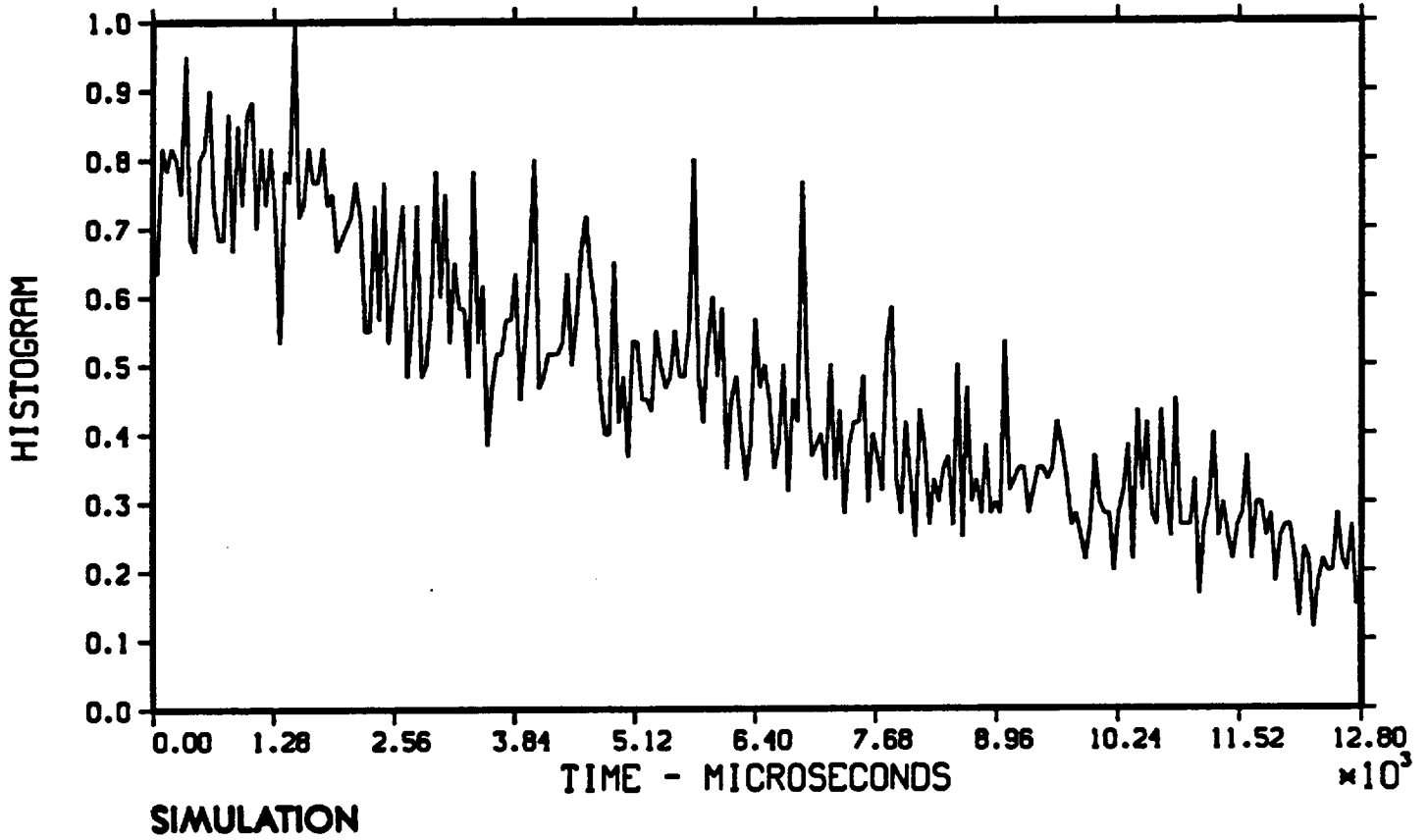

FIGURE 11. Distribution of the time between samples

ΔT 50.00
STD DEV 0.00

RUN 99.999
CHANNEL 1

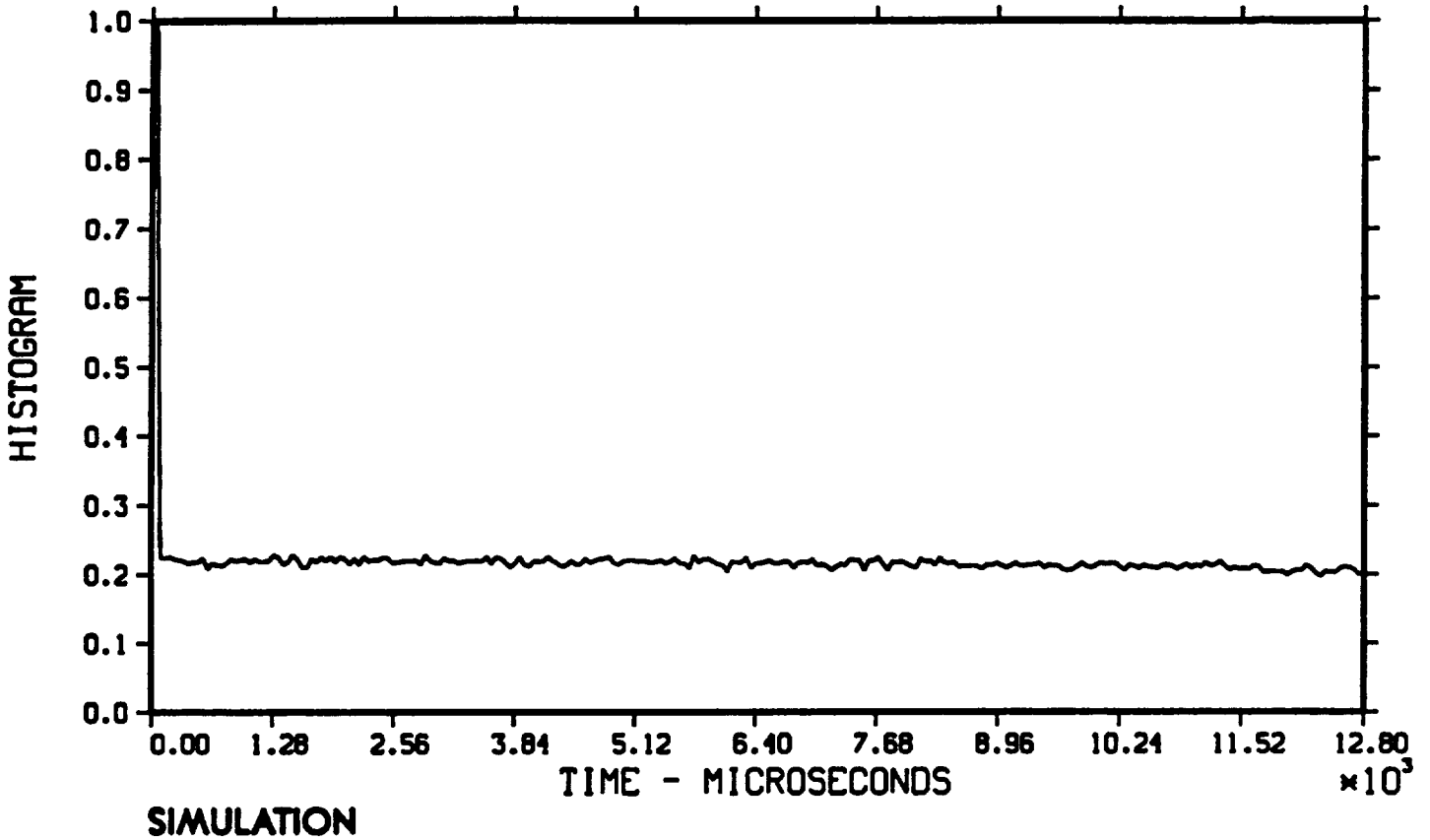

FIGURE 12. Number of samples per lagged time slot

5.0 Conclusions and Recommendations

Software has been developed, tested, and delivered that analyzes the velocity data from a TSI LV system and produces basic velocity statistics and performs conditional sampling or time series analysis. The software employs state-of-the-art techniques for analysis of the randomly sampled LV data. Based on the preliminary test results, the following recommendations are made.

1. The routines used in the software are generic and apply to any flow field and sampling procedure. However, for the case of conditional sampling with rotating machinery, these generic routines will probably require some modification for optimal performance. For instance, histogram clipping should be incorporated in those regions near the blades to eliminate erroneous readings when the blade partially blocks the measurement volume. In addition, isolation of the data for individual intrablade regions would assist in detailed analysis, diagnostics, or checkout.
2. This software should be integrated with available data acquisition routines using the MI-990 interface to provide a comprehensive capability for acquisition, reduction, and presentation of velocity data taken with the TSI LV system.
3. The LV software should be integrated with other laboratory instrumentation packages and tailored to the needs of the users for synergistic operation of the total system.

6.0 References

1. Bell, W. A., "LV Software Support for Supersonic Flow Analysis", Final Technical Report for October 1990 to October 1991, NASA Grant NAG3-1215, NASA LeRC.
2. Bell, W. A. and Lepicovsky, J., "LV Software Support for Supersonic Flow Analysis", AIAA Paper 92-3900, presented at the AIAA 17th Aerospace Ground Testing Conference, July 6-8, 1992, Nashville, TN.
3. Edwards, R. V. and Meyers, J. F., "An Overview of Particle Sampling Bias", *Second International Symposium on Applications of Laser Anemometry to Fluid Mechanics*, Lisbon, Portugal, July 1984.
4. Lepicovsky, J., Bell, W. A., and Ahuja, K. K., "Conditional Sampling with a Laser Velocimeter and Its Application for Large-Scale Turbulent Structure Measurement", LG83ER00001, Lockheed-Georgia Company, January 1983.
5. Bell, W. A., "Spectral Analysis of Laser Velocimeter Data with the Slotted Correlation Method", Paper AIAA-86-1102, AIAA/ASME 4th Fluid Mechanics, Plasma Dynamics, and Lasers Conference, Atlanta, GA, May 1986.