

Investigation of Microgravity Effects on Solidification Phenomena of Selected Materials

Carl R. Maag ¹ and Patricia A. Hansen ²

1. Science Applications International Corporation; Glendora, CA 91740
2. EER Systems; Seabrook, MD 20706,

ABSTRACT

A Get Away Special (GAS) experiment payload to investigate microgravity effects on solidification phenomena of selected experimental samples has been designed for flight. It is intended that the first flight of the assembly will a) investigate the p-n junction characteristics for advancing semi-conductor device applications, b) study the effects of gravity-driven convection on the growth of HgCd crystals, c) compare the textures of the sample which crystallizes in microgravity with those found in chondrite meteorites, and d) modify glass optical characteristics through divalent oxygen exchange.

The space flight experiment consists of many small furnaces. While the experiment payload is in the low gravity environment of orbital flight, the payload controller will sequentially activate the furnaces to heat samples to their melt state and then allow cooling to resolidification in a controlled fashion. The materials processed in the microgravity environment of space will be compared to the same materials processed on earth in a one-gravity environment. This paper discusses the design of all subassemblies (furnace, electronics, and power systems) in the experiment. A complete description of the experimental materials is also presented.

INTRODUCTION

The scientific objective of the GAS experiment payload is to investigate microgravity effects on solidification phenomena of selected experimental samples. The materials processed in the microgravity environment of space will be compared to the same materials processed on earth in a one-g environment. The basic objectives of the various materials processing experiments are:

1. The further understanding of solidification phenomena in space
2. The discovery of methods to produce new materials with improved properties over those available today.

The experiments to be included in the payload for a first flight are described in Table 1.

Payload overview

The GAS payload performing these materials processing experiments is to be contained in the "half-size" 2.5 cubic foot GAS canister, and will weigh no more than 100 pounds. The GAS canister will be sealed with a GN₂ internal atmosphere of 15 psia.

PAYLOAD DESCRIPTION

The payload assembly includes twelve (12) experiment furnaces, a power supply, an electronic control and data storage system, structural support, and mechanical/electrical interfaces to the GAS canister. The furnace interiors are plumbed to one purge port of the GAS top plate to provide a vacuum inside the furnaces.

A side view of the payload is shown in Figure 1. The subsystems are organized into two sections, the furnace module to the left and the support module (power, electronics) to the right. The GAS canister interfaces, interface plate and bumpers, are shown.

Structural subsystem

A cradle concept was developed to meet packaging requirements between the GAS container and experiment payload. The cradle provides structural support for the materials processing furnaces and associated support equipment. The payload is modular so that it can be reused for other missions with different scientific objectives.

The furnaces will operate in a vacuum environment for maximum efficiency while the remainder of the payload (support module) operates in a dry nitrogen atmosphere. Figure 2 shows a diagram of the manifold system that controls this operation. The dry nitrogen atmosphere will ensure that the batteries and electronics function properly and do not outgas. The support module is constructed in such a manner that the batteries, electronics and fuses are an integrated unit.

Furnace subsystem

The high temperature (1000°C) furnace is composed of a core and radiation reflectors that are matched to provide the best insulation, thus giving the highest temperatures with the least power input. The existing flight furnace requires 20 watts of electrical power to achieve the 1000°C design temperature. In addition, the furnace is designed to operate in a vacuum environment to eliminate convection through the gas that would otherwise fill the furnace.

The furnace core is the heating element. A nichrome heater coil coated with high temperature cement (Sauresin No. 29) provides the heat to a graphite crucible containing the sample. The furnace core and crucible are wrapped with insulation. The effectiveness of the insulation is demonstrated by the temperature measurement of 132°F at the furnace container wall during full power operation (furnace core and crucible at 1000°C).

Electronic subsystem

The electronics system for this payload is responsible for sequencing the payload furnaces during their operation, measuring and controlling the temperatures of each furnace to remain within a specified range, and recording deviations in the temperature data in non-volatile erasable programmable read only memory (EPROM) for post-flight processing of temperature profiles. In addition, the electronics will initiate these tasks upon receipt of a signal through the STS/GAS canister interface, provide electronics

ground support while the canister is in its flight configuration prior to Shuttle integration, and regulate the battery power to the electronics and furnaces.

The payload electronics design is comprised of two identical microprocessor controlled subsystems operating independently (string A and string B). Each subsystem controls, measures, and stores temperature data for up to 12 furnaces. All control is through on-board software that is programmed in Read Only Memory (ROM) before flight. Each electronics package is comprised of a central processing unit (CPU) microprocessor card, an EPROM card for data storage, a furnace select control card, an analog temperature measurement card with an analog-to-digital (A/D) converter and an STS/GAS canister interface card. Each card is linked via common data, address, and control bus to the CPU card.

Power subsystem

Alkaline batteries have been selected for the power supplies. There will be eight separate power supplies in parallel (4 supplies per string, A and B). The supplies will be based on D, C, and AA-size Duracell commercial batteries.

The furnaces are powered from 28 D-cells per string, each providing 118 Watt-hours of energy. The computers will utilize 6 C-cells per string, which will produce 10 Watt-hours of energy. The EPROM and A/D cards will operate with 25 and 10 AA-cells per string, providing each with 14 and 5 Watt-hours of energy, respectively.

EXPERIMENT DESCRIPTION

The experiment materials, along with the respective investigators for this flight, are listed in Table 1. The samples are on the order of one and one-half cubic centimeter each and are encapsulated in a hermetically-sealed quartz ampule. The ampule is contained in a closed graphite crucible. Figure 3 shows two ampules with encapsulated samples. The ring on the upper ampule is for handling purposes only. The sample subassembly is inserted into the core of a furnace. Each furnace with its contained sample is installed in the furnace module of the payload. Temperature sensors are incorporated into each furnace so that the temperature profiles may be recorded and furnace power may be controlled. Figure 4 shows the cross-section of a furnace assembly.

Experiment operation

The furnace, electronic, and power systems operate in concert with each other and without external control, except for the initial turn-on (actually a maximum of three signals) and an emergency turn-off. After the initial turn-on signal from the GAS Autonomous Payload Controller, the first furnace is actuated. The experiment controller program receives inputs from the thermal sensor in the furnace and proceeds to control power input so that an individually programmed sample thermal profile is followed. These profiles are summarized in Table 2.

After the heating and cooling cycle is completed, the second furnace is activated, and so on until the final sample is processed.

A special sequence is provided in the controller software, in the event of failure of a particular furnace to respond properly. It will be passed over and retried at the end of the furnace sequence, and shut down if operation remains abnormal. The software also enforces a shut down of each furnace run after a specified time period, nominally one hour.

All experiments will be performed twice. Each material will be placed in two separate furnaces. The six primary furnaces will contain one sample material each and will be activated first. The six secondary furnaces will allow each experiment to be repeated. Each furnace is activated sequentially until the final duplicate sample is processed.

Experiment evaluation

After flight, the sample ampules will be returned to the respective experimenters. The experimenters will examine their samples, compare them with corresponding ground-based experiments, and review the thermal profiles.

Table 1. Payload Experiments

No.	EXPERIMENT TITLE	MATERIAL	INVESTIGATORS	EXPERIMENT OBJECTIVES
1	Semiconductor Eutectic	SnSe-SnSe ₂	Alfred S. Yue, PhD Professor	Investigate the p-n junction characteristics for advancing semi-conductor device applications
2	IR Detector Crystal Growth	HgCd	Carl Maag	Study the effects of (absence of) gravity-driven convection on the growth of HgCd crystals
3	Chondrule Formation	Potassium Tetrasilicate	John Louie	Compare the textures of the sample which crystallizes in microgravity with those found in chondrite meteorites
4	Gradient Refractive Index of Glass	Zinc/Calcium Chloride Glass	Duncan Moore, PhD Professor of Optics	Modify glass optical characteristics through divalent oxygen exchange
5	Unique Aluminum Alloy	Al Alloy	Edward Eckert	Study the effects of Al Alloy casting in Zero-g.
THE ABOVE MATERIALS HAVE BEEN APPROVED FOR USE BY THE GSFC MATERIALS BRANCH				

Table 2. Experiment Time-Temperature Profiles

<p>SEMICONDUCTOR EUTECTIC Heat as rapidly as possible to 700°C, hold for 20 minutes</p> <p>(a) Cool at 5°C/min. to 630°C, power off (b) Cool at 1°C/min. to 630°C, power off</p> <p>AL ALLOY Heat as rapidly as possible to 950°C, hold for 45 minutes, power off.</p> <p>IR DETECTOR CRYSTAL GROWTH Heat to 900°C, hold for 20 minutes</p> <p>(a) Cool at 5°C/min. to 670°C, power off (b) Cool at 5°C/min. to 810°C, cool at 1°C/min. to 690°C, power off</p> <p>CHONDRULE FORMATION Heat to 750°C, hold for 20 minutes Cool at 5°C/min. to 600°C, power off</p> <p>GRADIENT REFRACTIVE INDEX OF GLASS (a) Heat to 950°C, hold for 1 min., power off (b) Heat to 950°C, hold for 10 min., power off</p>
--

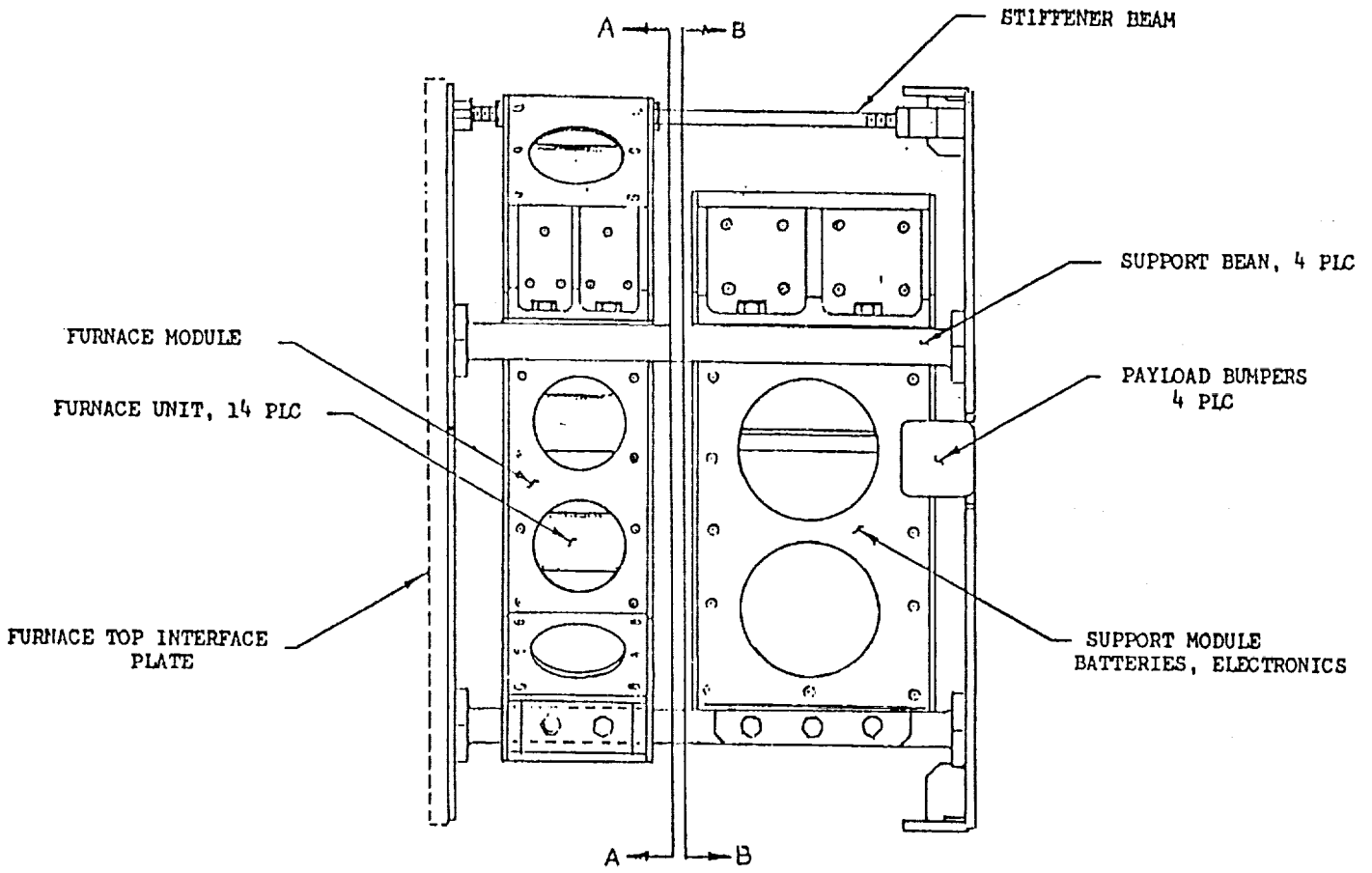

Fig.1. Cross-sectional diagram of payload

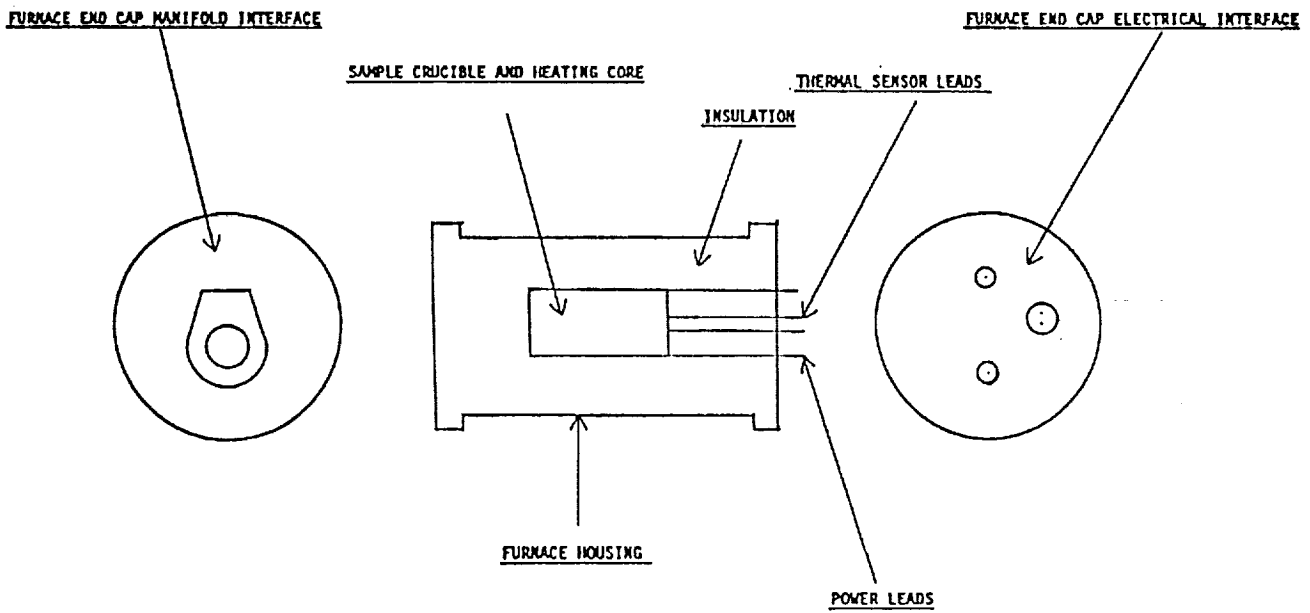

Fig. 2. Furnace manifold system

ORIGINAL PAGE
BLACK AND WHITE PHOTOGRAPH

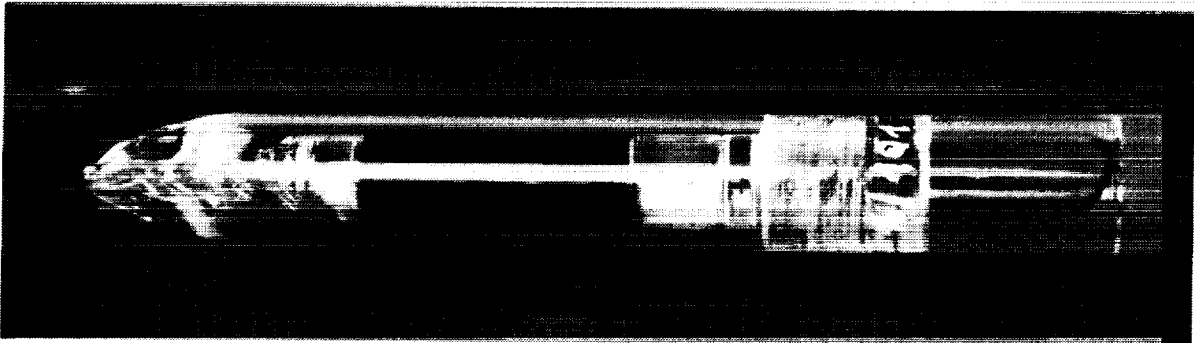
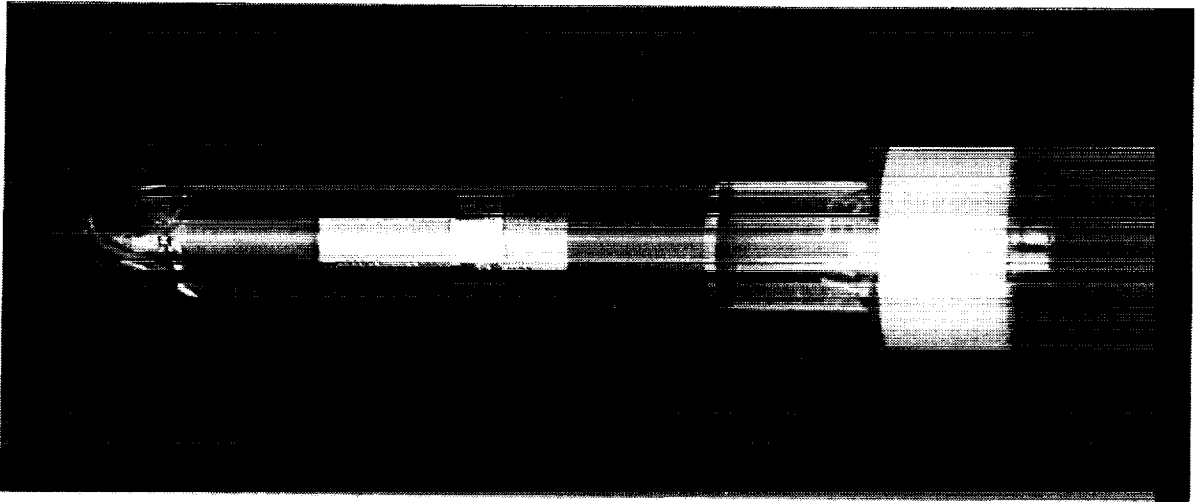

Fig. 3. Quartz ampule with encapsulated sample.

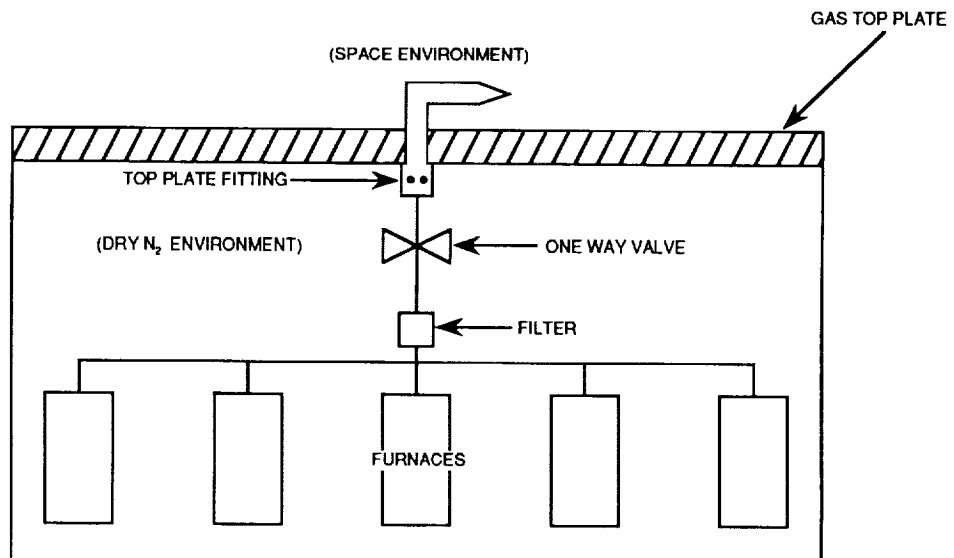

Fig. 4. Furnace assembly.

