

PALLADIUM-CHROMIUM STATIC STRAIN GAGES FOR HIGH TEMPERATURES

Jih-Fen Lei
Sverdrup Technology, Inc
NASA Lewis Research Center Group
Cleveland, OH

ABSTRACT

An electrical resistance strain gage that can provide accurate static strain measurement to a temperature of 1500°F or above is being developed both in fine wire and thin film forms. The gage is designed to be temperature compensated on any substrate material. It has a dual element: the gage element is a special alloy, palladium-13wt% chromium (PdCr), and the compensator element is platinum (Pt). Earlier results of a PdCr based wire gage indicated that the apparent strain of this gage can be minimized and the repeatability of the apparent strain can be improved by prestabilizing the gage on the substrate for a long period of time. However, this kind of prestabilization is not practical in many applications and therefore the development of a wire gage which is prestabilized before installation on the substrate is desirable. This paper will present our recent progress in the development of a prestabilized wire gage which can provide meaningful strain data for the first thermal cycle. A weldable PdCr gage is also being developed for field testing where conventional flame-spraying installation can not be applied. This weldable gage is narrower than a previously reported gage, thereby allowing the gage to be more resistant to buckling under compressive loads. Some preliminary results of a prestabilized wire gage flame-sprayed directly on IN100, an engine material, and a weldable gage spot-welded on IN100 and SCS-6/B21-S Titanium Matrix Composite (TMC), a National Aero-Space Plane (NASP) structure material, will be reported. Progress on the development of a weldable thin film gage will also be addressed. The measurement technique and procedures for using thin PdCr based gage as well as some considerations related to the installation procedures and the lead wire effect will be discussed.

INTRODUCTION

An electrical resistance strain gage that can provide accurate static strain measurement to a temperature higher than the limit of the conventional technology is urgently needed for high temperature materials studies and hot structure design validation. A PdCr based strain gage that has shown some promise for high temperature application is being further developed under the support of the National Aero-Space Plane (NASP, X-30) program. Previous results

of a PdCr based wire gage suggested that the apparent strain of this temperature compensated gage is relatively small (within 750 microstrain ($\mu\text{in/in}$)) and repeatable (within 100 microstrain between thermal cycles to 1470°F) after the gage is prestabilized on the substrate at 1470°F for 50 hours [1]. This kind of prestabilization process on the test article is not allowed for many practical tests where the first thermal cycle data is needed. A wire gage which is prestabilized before installation on the substrate is therefore required. This paper will present our recent progress in developing a prestabilized wire gage.

The maximum use temperature for a PdCr based wire gage is currently limited to 1470°F due to the presence of the impurities in the PdCr wire, while a sputter deposited PdCr thin film gage has demonstrated the possibility of extending the use of the PdCr based gage to a higher temperature of approximately 1800°F [2]. A weldable thin film gage is being developed for applications where sputtering a thin film gage directly on a large test article, such as the NASP airframe, is impossible. A weldable thin film gage is a thin film gage fabricated on a thin metal shim, which is then transported and installed on the test article by welding. The status of the development of a weldable thin film gage will be reviewed. Some considerations related to the installation of the gage and measurement techniques will also be addressed.

GAGE FABRICATION AND INSTALLATION

I. Wire Gage

The PdCr based gage is designed to be temperature compensated on any substrate material. It has a dual element: the gage element is .001" (1 mil) PdCr wire and the compensator element is .001" (1 mil) platinum wire. The Pt compensator is around the periphery of the PdCr gage grid to minimize the effect of the temperature gradient. Fig. 1 shows a wire gage with the high temperature tape frame used for flame spray mounting. The configuration of this gage is similar to that of the previous gage [1] except (1) the PdCr wire is heat-treated (prestabilized) before winding into gages, (2) the spacing between the gage grids is decreased so that the width of a total gage is decreased from 0.42" to 0.16" and (3) the length and therefore the resistance of the platinum compensator is decreased so that the gage is closer to a one-to-one bridge system. The nominal resistances of the gage and the compensator are 120 ohms and 5 ohms, respectively. There are three gage lead wires extended from the gage system with a common lead wire shared by both the gage and the compensator. These gage lead wires are .003" (3 mil) diameter PdCr wire.

The wire gage is mounted on the test article with flame-sprayed powders. A layer of nickel-chromium-aluminide is first applied to the substrate as the bondcoat and then a layer of alumina is applied as the precoat. The gage is then taped down onto the precoat by means of high temperature adhesive strips. A mixture coating of alumina and zirconia which provides oxidation protection for the gage is applied to the open areas between the strips. The strips are then removed and the final alumina mixture overcoat is applied. Since both PdCr and Pt

were found to be very sensitive to impurities such as aluminum and silicon, care must be taken during handling and installation to protect the gage from contamination. The spraying powders need to be pure and the tape residue has to be completely removed. Fig. 2 shows two prestabilized wire gages installed on a 0.125" thick IN100 coupon.

II. Thin Film Gage

Thin film gages provide a means for minimally intrusive surface strain measurements, and are therefore advantageous for use in harsh testing environments. Fig. 3 shows a compensated thin film gage fabricated on an alumina test bar. The configuration of this thin film gage is similar to that of the wire gage with a Pt compensator located around the periphery of the PdCr gage. This thin film gage is prepared in a Class 1000 clean room by means of sputter deposition, photolithography, and chemical etching techniques. The size of a total gage is approximately 0.19" (5mm) long and 0.17" (4.3mm) wide. PdCr .003" lead wires were attached to the three thin film lead pads by means of parallel gap welding.

III. Weldable Gage

A .003" thick Hastelloy-X shim is used as the carrier of the weldable gage. The wire weldable gage is fabricated simply by flame-spraying the wire gage onto the shim with the process described earlier. The fabrication process of a thin film gage on the weldable Hastelloy-X shim is similar to that of the gage fabricated on an alumina substrate except a layer of insulating material, alumina, is deposited in between the conductive Hastelloy-X shim and the gage element. This insulation layer has to be able to provide enough resistance to ground up to the maximum use temperature.

The weldable gage can be installed to the test article simply by using a spot-welder. Surfaces of the Hastelloy-X shim and the substrate material need to be cleaned before welding to remove the possible surface oxides. This can be done by sand blasting the surface area with fine grit powders followed by cleaning with alcohol. Since the performance of the weldable gage depends on good welding attachments, it can be applied only to the weldable base materials. In spite of this and other limitations, such as the stiffening effect and the stress concentrations at the welds, the weldable gage offers an advantage when the installation must be done in the test field and flame-spraying or sputter deposition cannot be applied. Fig. 4 shows two weldable wire gages welded on a 0.025" thick SCS-6/B21-S TMC coupon and Fig. 5 shows a weldable thin film gage welded on a 0.125" thick IN100 coupon. The welding energy used in these two cases was approximately 48-50 watts/second.

IV. Installation of Extended Lead Wires (Trunk Leads) and Thermocouples

The trunk leads which extend from the gage to the measurement system are attached to the gage lead wires by means of spot-welding. Alumina beads are threaded on the trunk leads to provide oxidation protection and to prevent the wires from shorting to each other.

The first two inches of the wires are fixed on the substrate following a "Z" loop for the strain relief, as shown in Figs. 2 and 5. Several lead wire materials, including chromel, Hoskins 875, and platinum, were studied for their suitability for high temperature static strain measurement. The results of this study are discussed in Appendix A. Thermocouples which are needed for monitoring the temperature of the gages and for detecting any temperature gradient across the gage are also spot-welded to the substrate. Accurate temperature measurement is necessary for accurate correction of the apparent strain.

MEASUREMENT TECHNIQUE AND PROCEDURE

This PdCr based gage provides a unique ability to compensate for temperature effects on materials with a wide range of thermal expansion coefficients by simply varying the resistors of an external circuit (Fig. 6). However, to perfectly compensate for the unwanted temperature induced errors, a pre-calibration process is needed in order to determine the best value of the ballast resistor (R_B) [3]. This pre-calibration process should be done at least once for each set of substrate material and lead wires to accommodate for the temperature dependent effects such as the difference in thermal coefficient of expansion between the gage, compensator, and the substrate materials, the change in lead wire resistance, the thermal EMF generated at the junctions of dissimilar materials, and the leakage resistance between the gage and the substrate. This pre-calibration process is best done on the test article if a thermal cycle to the maximum use temperature is allowed. Otherwise, it can be duplicated on a coupon only if the coupon material is the same as that of the test article. Also the lead wire material and its length used in the hot zone must be the same as in the real test. The procedures for this pre-calibration test are described in Appendix B.

Once the value of the ballast resistor R_B is determined through the pre-calibration process, the wheatstone bridge system shown in Fig. 6 is then balanced at room temperature by adjusting the ratio between the bridge balancing resistor R_1 and R_2 so that $R_1/(R_1+R_2)=(R_G+r_{lg})/(R_B+R_C+r_{lc}+R_G+r_{lg})$. R_G and R_C are the resistances of the gage and compensator, respectively, and r_{lg} and r_{lc} are the resistances of the lead wires connected to the gage and compensator, respectively. The bridge is now ready for apparent strain and mechanical strain measurements. Notice that the accuracy and stability of this measurement strongly depend on the accuracy and stability of the ballast resistor R_B and the bridge balancing resistors R_1 and R_2 . Precision decade resistors which are temperature insensitive are therefore needed.

CHARACTERISTICS OF THE GAGE

A. Wire Gage

The flame-sprayed prestabilized wire gage has been tested on IN100, an engine material, and the weldable wire gage has been evaluated on both IN100 and SCS- β 21S TMC, a NASP structure material. Fig. 7 presents typical resistance change versus temperature curves for the effective gage ($R_G^* = R_G + r_{lg}$) and compensator ($R_C^* = R_C + r_{lc}$) of a prestabilized gage during the pre-calibration process. In this case, the gage was flame-sprayed directly on an IN100 coupon with Pt .010" wires used as trunk leads. As shown, both curves are quite linear and repeatable between a heat-up and cool-down cycle to 1450°F. This suggested that this prestabilized gage is stable and repeatable from the very first thermal cycle.

Fig. 8 is the apparent strain vs temperature characteristics of this prestabilized gage during two thermal cycles to 1450°F. As described in Appendix B, the resistance of the ballast resistor used in the wheatstone bridge circuit was calculated from Fig. 7 and was 109.89 ohms. The bridge system was balanced with $R_1/(R_1 + R_2) = 0.516$, which was very close to a one-to-one bridge. As shown in Fig. 8, the change in apparent strain of this prestabilized gage is within 1200 microstrain with a repeatability within 100 microstrain between thermal cycles to 1450°F. The magnitude of the apparent strain of this prestabilized PdCr gage, although very small compared to that of the other high temperature strain gages, is large compared to that of the PdCr gage stabilized on the test article. This is because the PdCr wire is oxidized during the prestabilization process and the resistance versus temperature curve of the prestabilized gage is found to be not as linear as that of the gage which is stabilized on the part. Note that the shape of the apparent strain vs temperature curves and the value of the residual apparent strain of a compensated gage simply reflect the nonlinearity of the resistivity versus temperature characteristic of the gage and compensator element. However, the repeatability of the apparent strain of this prestabilized gage is comparable to that of the gage which is stabilized on the substrate. Furthermore, the initial thermal cycle data are meaningful due to their reproducibility from the very first thermal cycle.

There was another prestabilization process explored. The PdCr gage was flattened and heat-treated before the construction of the Pt compensator and the joining of the lead wires. The properties of this type of prestabilized gage were found to be comparable to that of the wire stabilized gage; however, the fabrication of a flattened gage is much more complicated. In addition, the weld joints between the flattened gage wire and the round lead wire were found to be less durable. As a result, the flatten, heat-treated method was abandoned.

Fig. 9 shows the apparent strain vs temperature characteristics of a weldable wire gage during two thermal cycles to 1450°F. The gage is welded on a 0.125" thick IN100 coupon. As can be seen, the characteristic of this weldable gage is similar to that of the gage directly installed on the IN100 (Fig. 8). The reproducibility of the apparent strain of these two types of gages is comparable, while the weldable gage has a slightly larger change in apparent strain in the temperature range. This may have resulted from the difference in the coefficients of thermal expansion between the gage, Hastelloy-X shim, and the IN100 coupon. No delamination of the weldable gage from the substrate is observed after several thermal cycles to 1450°F.

Fig. 10 shows the apparent strain vs temperature characteristics of a weldable gage on a coupon of SCS-6/Beta 21S TMC. This 0.025" thick TMC coupon is 3 plies with a fiber

layup of [0,90,0]. The gage is spot-welded along the top fiber direction as shown in the Fig.4. As shown, the apparent strain of this weldable gage on TMC during the first two thermal cycles to 1200°F (Fig. 10a) is very similar to that of the gages on IN100. This indicates that the PdCr gage is well temperature-compensated both on IN100 and on TMC. However, as the gage and the TMC are exposed to a higher temperature, the repeatability of the apparent strain of the gage between thermal cycles decreases. As seen from Fig. 10b, there is approximately 400 microstrain zero shift at 1300°F between two 1300°F thermal cycles, although the shape of the apparent strain curve is similar to that of the 1200°F thermal cycles. Fig. 10c presents the apparent strain of the gage on TMC during three thermal cycles to 1420°F. As shown, the first cycle data is similar to that of the gage on IN100; however, data for the second and third cycles are not characteristic of the PdCr gage. There is a large drop of the apparent strain at temperatures above 1300°F during the second heat-up cycle while there is a large increase of the apparent strain above 1300°F during the third heat-up cycle. This indicates the substrate material TMC is not stable at temperatures above 1300°F. Exposure to a higher temperature may result in fiber shifting, laminate bending, or other permanent changes in the material. There is no gage delamination from the TMC substrate occurring after these tests; however, the TMC substrate does warp.

The critical compressive strain for a weldable gage to start buckling depends strongly on the width, but not much on the length, of the gage. The narrower the gage is, the higher its critical strain for buckling [4]. Furthermore, the difference in coefficients of thermal expansion between the shim and the test article may either increase or decrease the critical buckling strain. When the thermal expansion coefficient of the shim material is greater than that of the substrate material to which it is welded, an increase in temperature will produce a compressive strain in the shim. This will effectively reduce the critical strain limit for the imposed mechanical strain. For example, the thermal expansion coefficient of the Hastelloy-X and the TMC are approximately 9 and 6 ppm/°F, respectively. Heating to 1200°F will then produce a compressive mechanical strain of 3600 microstrain in the Hastelloy-X shim. Since the gage with a previous design (0.42" wide) has a critical strain for buckling of approximately 1500 microstrain, it would buckle and delaminate from the substrate after the gage is exposed to 1200°F. This is the main reason for decreasing the size of the gage. The gage with this new design (0.16") has a critical strain for buckling of approximately 8000 microstrain and can therefore survive to a much higher temperature without delamination.

It should be noted that since materials like TMC, having a thermal expansion coefficient that is fiber orientation dependent, a weldable gage may be usable along one fiber direction but not along the other direction. Alignment of the weldable gage on the TMC is therefore very important. Values of apparent strain of the gage reported in this paper were calculated assuming a constant gage factor of 1.4. The gage factor characteristic of the prestabilized gage in addition to how well the strain transfers through the weldable gage have yet to be determined.

B. Thin Film Gage

Fig. 11 presents the change in resistance versus temperature of the effective gage (R_G^*)

and the compensator (R_c^*) of a thin film gage during the pre-calibration process. In this case, the gage was fabricated on an alumina cantilever beam with Pt 0.010" wire used as trunk leads as shown in Fig. 3. Both curves are quite linear and repeatable during heat-up and cool-down cycles to 1850°F. This makes the temperature compensation possible for this thin film gage up to this high temperature. In this case, the gage has been pre-heated at 1850°F for one hour. Fig. 12 presents the apparent strain versus temperature characteristics of the gage during a thermal cycle to 1850°F. As shown, the shape of the apparent strain curve of this thin film gage is similar to that of the wire gage but with a larger apparent strain variation between the heat-up and cool-down cycles. More work is underway to improve the properties of thin film gage. As for the thin film weldable gage, an insulation layer that can provide at least 1 Mohm up to the maximum use temperature (1900°F) is still being developed. As shown in Fig. 5, studies of the gage welded on an IN100 coupon indicated that the attachment of thin PdCr weldable gage on IN100 is durable. No gage delamination from the IN100 coupon occurred after several thermal cycles to 1850°F.

SUMMARY

The procedures for fabricating a prestabilized wire gage have been established. This prestabilized wire gage can provide meaningful first thermal cycle data. A weldable gage, which can be used in the field where the conventional flame-spray technique installation can not be applied, has also been developed. The apparent strain characteristic of a weldable gage is similar to that of the gage installed directly on the substrate. However, the gage factor characteristic of this weldable gage, in addition to how well the strain transfers through the .003" Hastelloy shim, has yet to be determined. As for the thin film weldable gage, the preliminary results indicated the possibility of extending the use of thin PdCr based gage to approximately 1850°F; work is underway to further optimize and characterize its properties. More gages, both wire and thin film, will be tested in the near future in order to establish a statistical database for thin PdCr based resistance strain gage.

REFERENCES

1. J.-F. Lei, "A Resistance Strain Gage with Repeatable and Cancelable Apparent Strain for Use to 800°C", NASA Contractor Report 185256, July 1990.
2. J.-F. Lei, "Palladium-Chromium Static Strain Gage for High Temperature Propulsion Systems", The Third Annual Health Monitoring Conference for Space Propulsion Systems Proceedings, p.391-400, Nov. 1991.
3. J.-F. Lei, D. R. Englund and C. Croom, "The Temperature Compensation Technique for a PdCr Resistance Strain Gage", SEM Conference Proceedings, Fall, 1991.

4. F. F. Hines, "Weldable Bonded Resistance Strain Gages", WRS GC Proceedings, May 1960.

APPENDIX

A. Trunk Lead Effects

PdCr heavy wires were originally used as trunk leads for this PdCr based gage. However, due to its high cost and limited availability, several alternate lead wire materials were studied. These include chromel (Ni10Cr), Hoskins 875 (Fe22.5Cr5.5Al0.5Si0.1C), and Pt. The values of some of the most important properties of these lead wire materials as well as their relative rankings are listed in Table I. The selection criteria for the trunk leads are (1) the lead material should not react with gage lead, (2) the resistivity (ρ), the temperature coefficient of resistivity (α), and the product of ρ and α of the trunk lead should be small so as not to influence the gage property, and (3) it should have a high melting temperature (M.T.), be oxidation resistant and stable at high temperatures, and undergo no phase transition. Among all the materials studied, Pt has the highest melting temperature, smallest resistivity and the best stability; however, it has a very large α and product of $\rho\alpha$ and is expensive. Both chromel and Hoskins 875 wire experience phase transitions in some temperature range, and therefore do not have linear resistance vs temperature (R vs T) curves. However, they have a smaller $\rho\alpha$ product and are cheaper than Pt. In comparison, Hoskins 875 is a better choice than chromel for static strain measurement because it is more stable at high temperatures and its R vs T characteristic is more repeatable (Fig. A1). However, large diameter wire is needed to minimize the total lead wire resistance. Overall, Pt and Hoskins 875 may replace PdCr as trunk leads when PdCr heavy wires are not available.

Table I. Properties and Relative Ranking of Some Lead Wire Materials. The Lower the Ranking, the Better the Material.

	MT (°F)	ρ ($\mu\Omega$ -cm)	α ($\mu\Omega/\Omega^\circ\text{F}$)	$\rho\alpha$ ($\mu\Omega$ - cm/ $^\circ\text{F}$)	Phase Trans.	Stable	\$
Chromel (Ni10Cr)	2593	70	175	0.012	Yes	3	1
Hoskins 875 (Fe22Cr5Al.5Si)	2770	145	87	0.013	Yes	2	2
Platinum (Pt)	3223	11	1637	0.018	No	1	3
Palladium- Chromium (Pd13Cr)	2372	80	98	0.008	No	2	4

B. Pre-calibration Procedure

The value of the ballast resistor R_B required for temperature compensation is

$$R_B = R_C^* (\alpha_C^* - \alpha_G^*) / \alpha_G^*$$

where R_C^* is the effective compensator resistor, i.e., $R_C^* = R_C + r_{lc}$

α_C^* is the effective temperature coefficient of resistance of the effective compensator resistor, such that $\alpha_C^* = \Delta R_C^* / (R_C^* \Delta T)$, and

α_G^* is the effective temperature coefficient of resistance of the effective gage resistor, such that $\alpha_G^* = \Delta R_G^* / (R_G^* \Delta T)$, where $R_G^* = R_G + r_{lg}$.

The values of the R_C^* , α_C^* and α_G^* are determined during a cycle of heating to and cooling from the maximum test temperature. Data are taken from room temperature to the optimum test temperature in 200°F steps. The oven temperature is stabilized within $\pm 2^\circ\text{F}$ during the data acquisition process and the substrate is isothermal to within $\pm 10^\circ\text{F}$ along the gage before the data are recorded.

At each test temperature, the lead wires from the gage system are first connected to the electrical circuit, as in Fig. B1(a), to obtain R_G^* , and are then connected to the circuit as in Fig. B1(b) to obtain R_C^* . Two digital multimeters and a thermometer are needed in this process. Based on the obtained R^* vs temperature (T) data, α^* values can be obtained by curve fitting.

PdCr Temperature Compensated Strain Gage

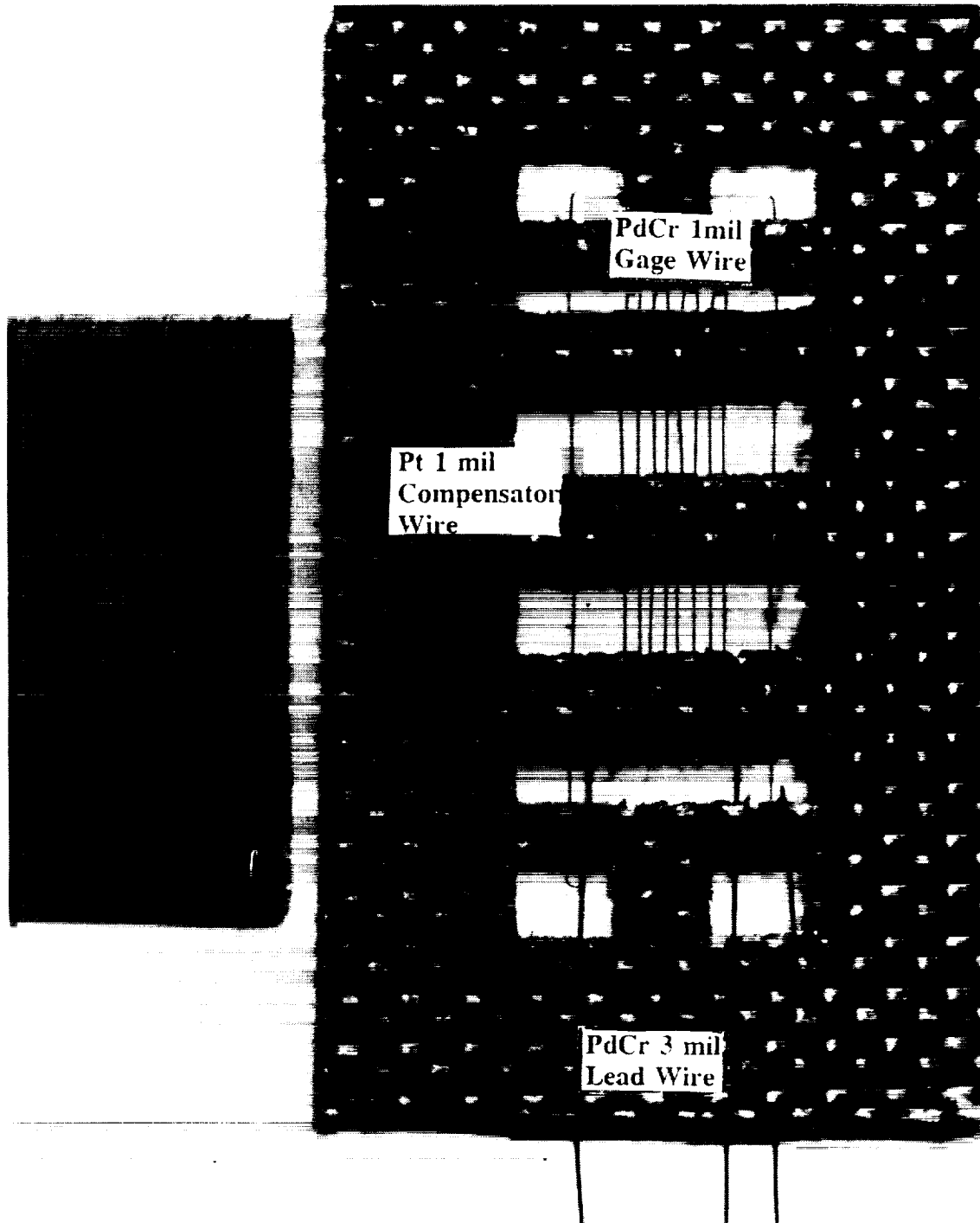

Fig. 1. A PdCr/Pt temperature-compensated wire gage with the high temperature tape frame used for flame spray mounting. (The scale is in inches).

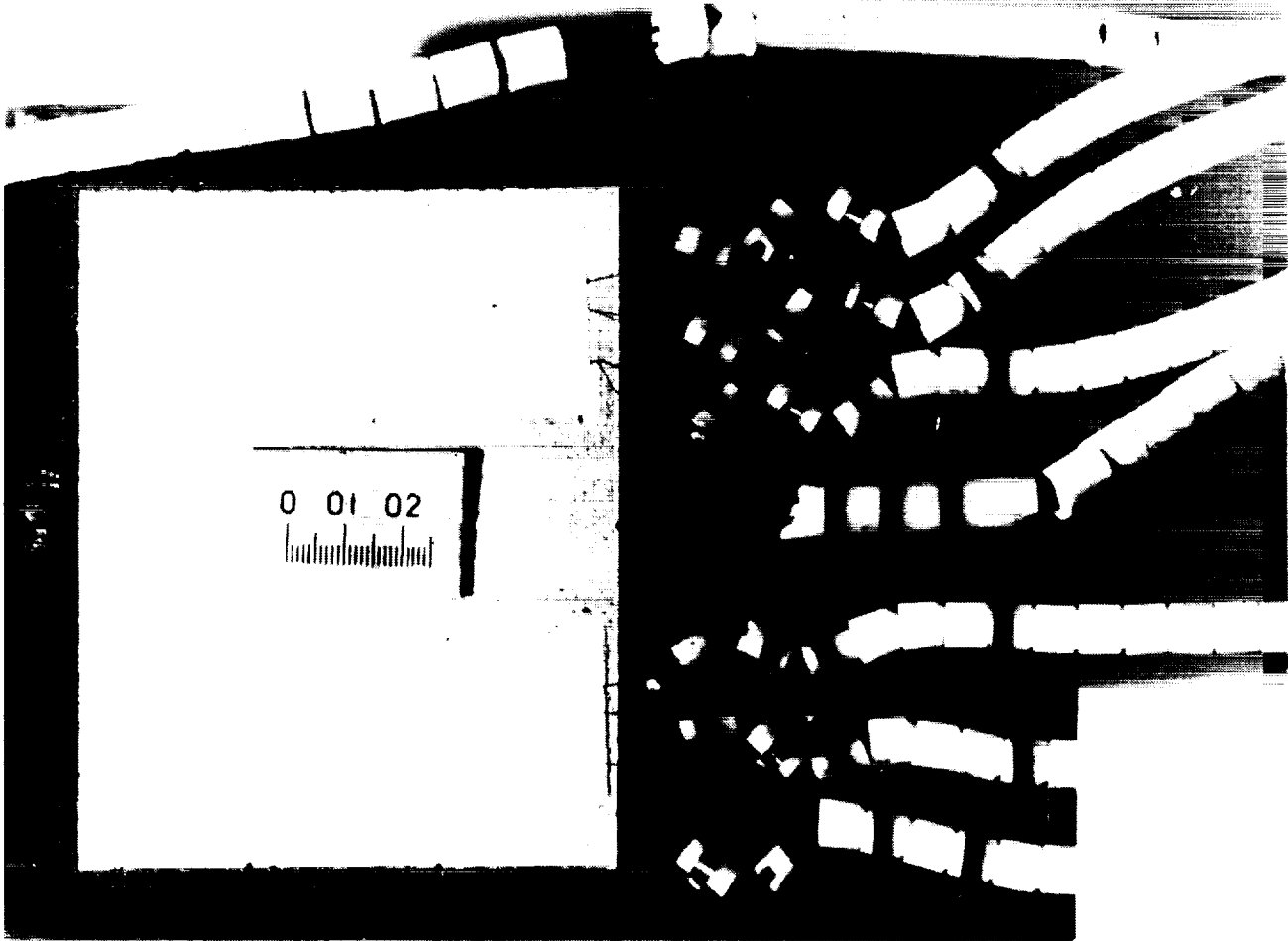

Fig. 2. Two prestabilized wire gages installed on an IN100 coupon. There are three lead wires extended from each gage. There are also two thermocouples welded on the coupon.

PdCr/Pt Thin Film Strain Gage on Alumina Cantilever Bar

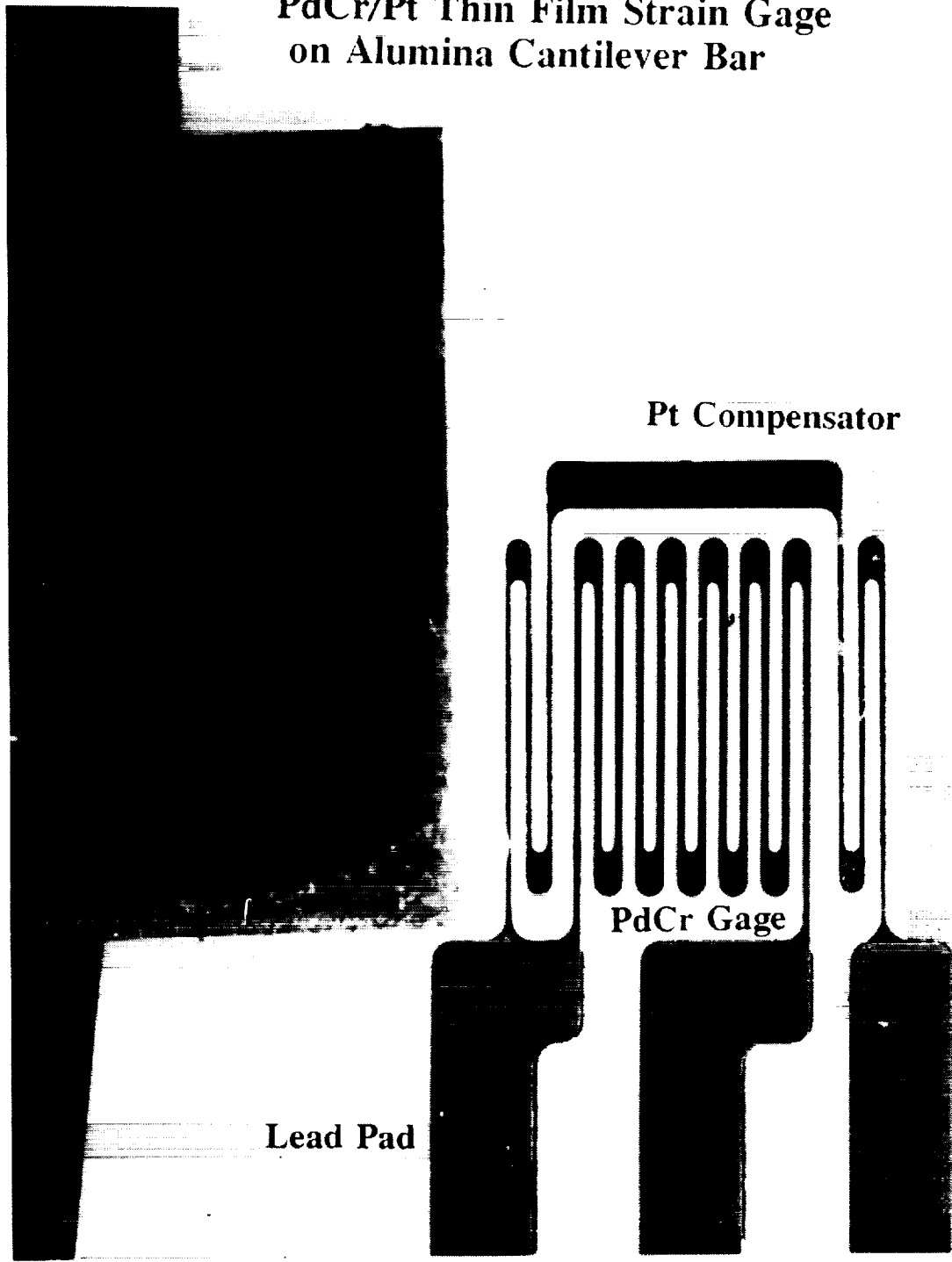

Fig. 3. A PdCr/Pt temperature-compensated thin film gage fabricated on an alumina substrate. (The scale is in millimeters).

Two PdCr Weldable Gages Spot-Welded
on a SCS-6/Beta 21S TMC [0,90,0]

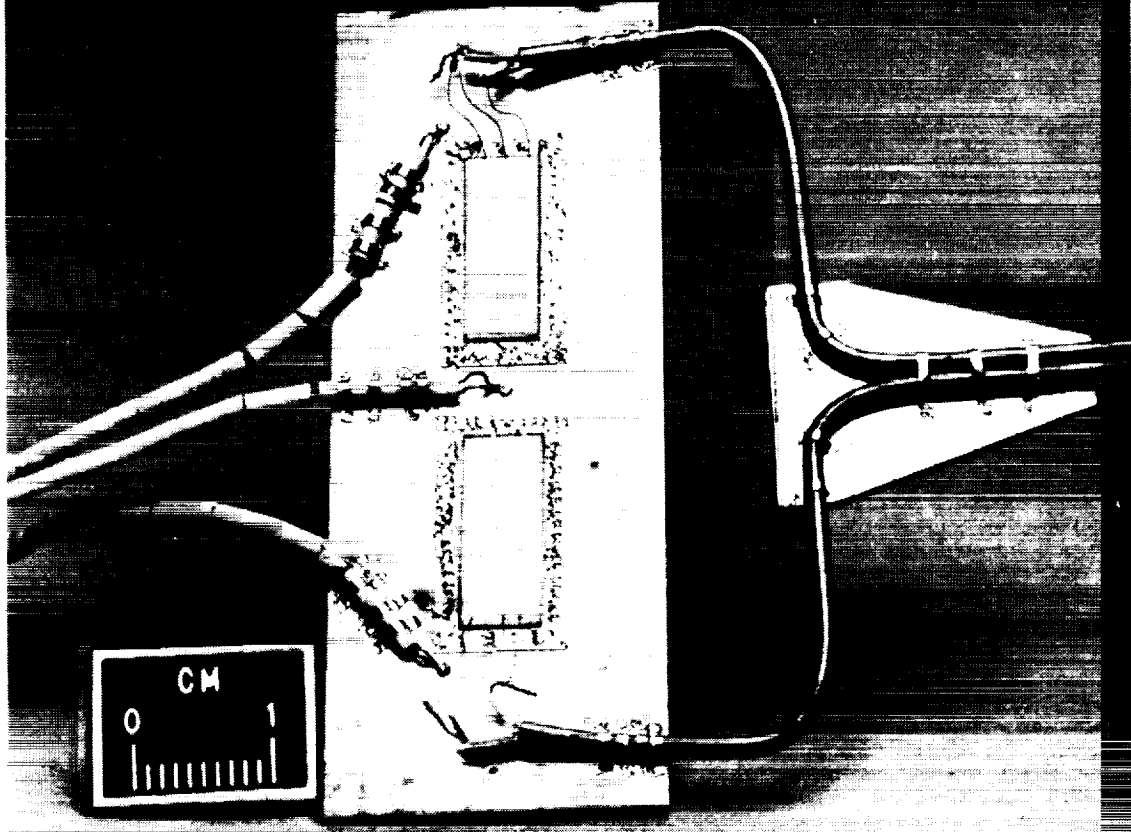

Fig. 4. Two weldable wire gages welded on a SCS-6/B21-S titanium matrix composite (TMC) coupon. The gages are welded along the top fiber direction (↑). There are three thermocouples spot-welded on the coupon.

A PdCr/Pt Thin Film Weldable Gage Spot-Welded on an IN100 Coupon

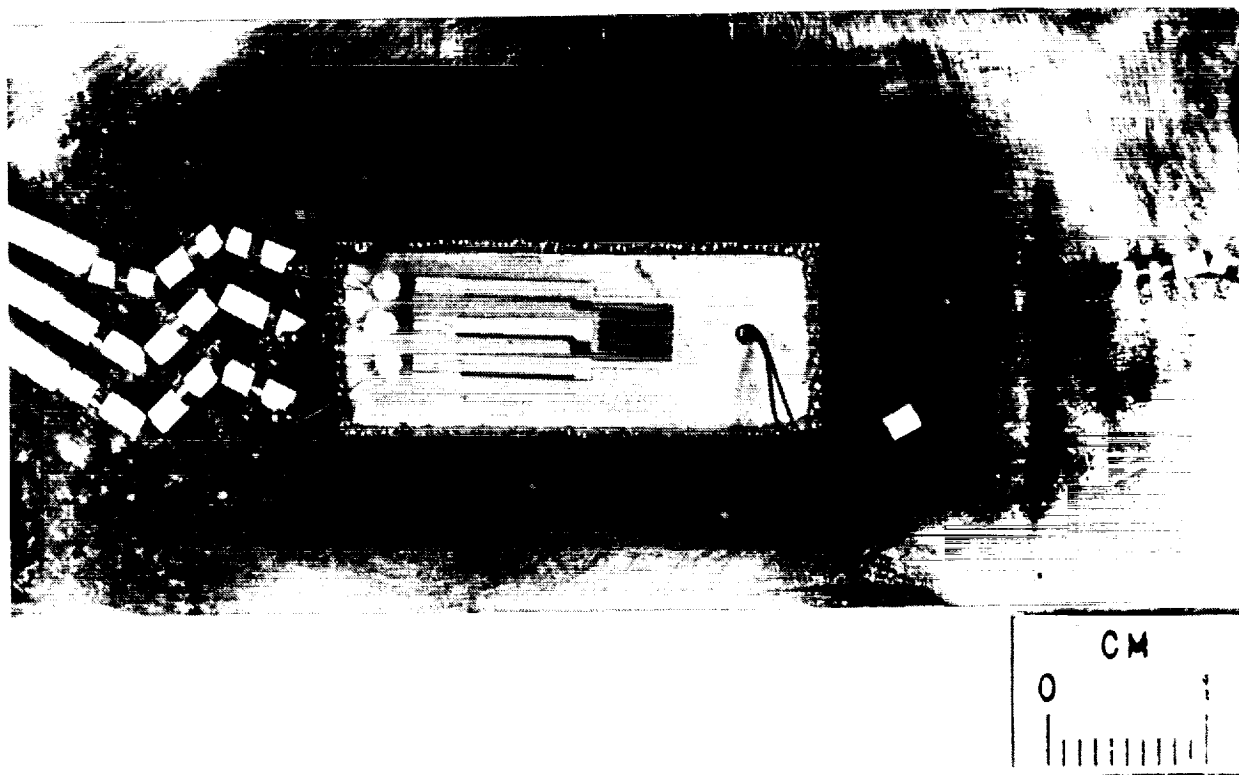

Fig. 5. A weldable thin film gage welded on an IN100 coupon. A 0.003" thick Hastelloy-X shim is used as the carrier of the weldable gage. There is also a thermocouple welded on the coupon.

Strain Gage Measurement Circuit

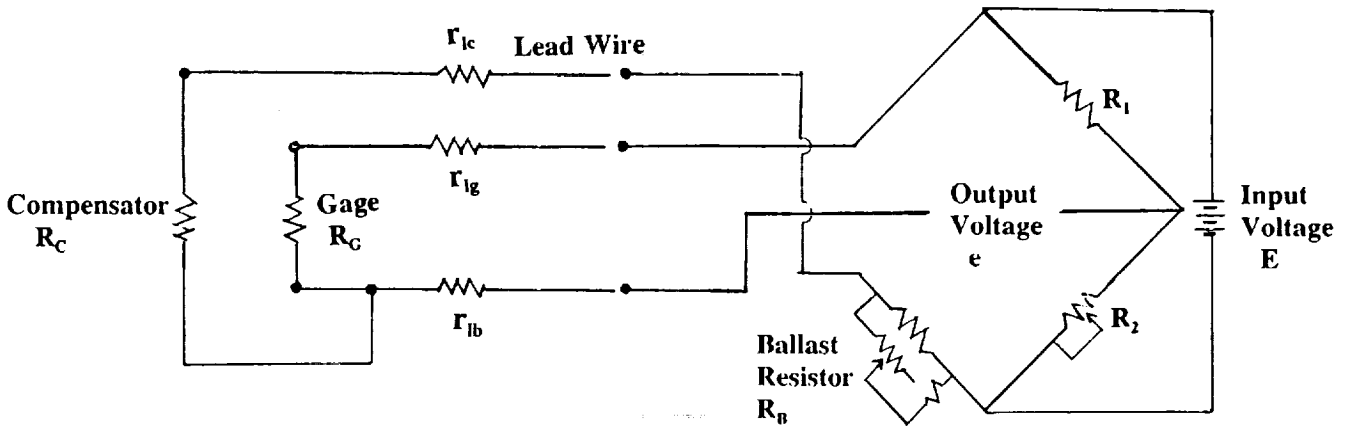
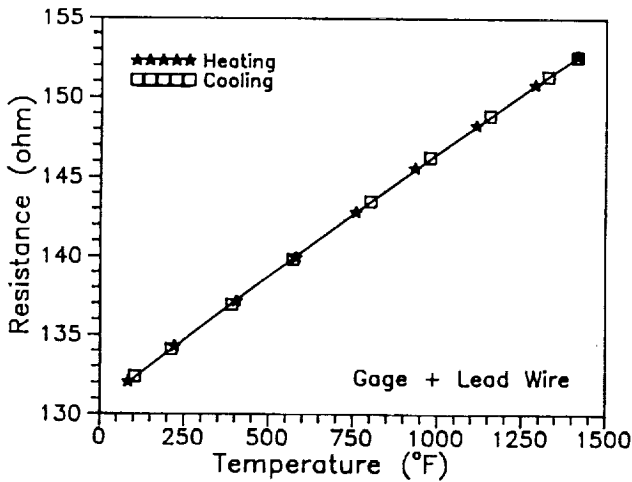
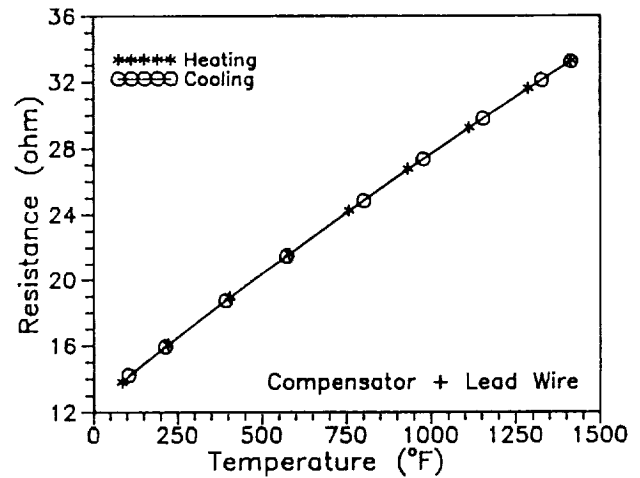

Fig. 6. Strain gage measurement circuit. The value of the ballast resistor, R_B , needed for temperature compensation is $R_B = R_C^* (\alpha_C^* - \alpha_G^*) / \alpha_G^*$, where $R_C^* = R_C + r_{lc}$, $\alpha_C^* = \Delta R_C^* / (R_C^* \Delta T)$ and $R_G^* = R_G + r_{lg}$, $\alpha_G^* = \Delta R_G^* / (R_G^* \Delta T)$.



(a)



(b)

Fig. 7. Resistance vs temperature curves for the (a) effective gage $R_G^* (=R_G + r_{lg})$ and (b) effective compensator $R_C^* (=R_C + r_{lc})$ of a prestabilized wire gage during the pre-calibration. Values of R_G^* , R_C^* , α_G^* and α_C^* needed for calculating R_B are obtained by curve fitting.

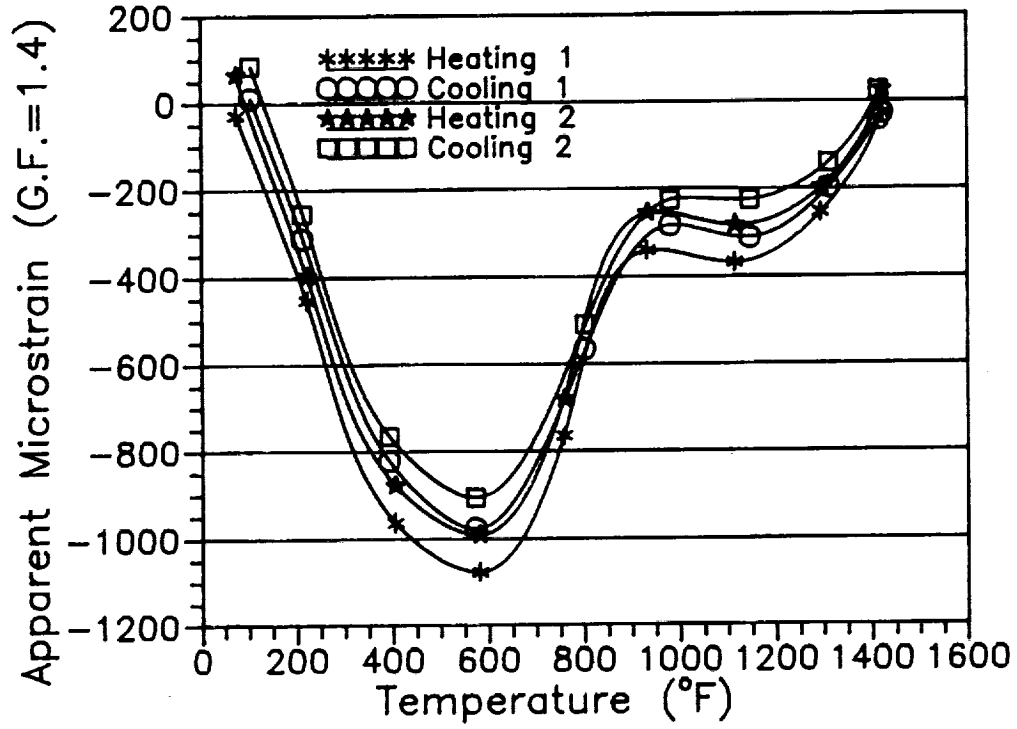

Fig. 8. Apparent strain vs temperature curves of a prestabilized PdCr/Pt wire gage during two thermal cycles to 1450°F. The gage is installed on an IN100 coupon by flame-spray technique. Values of apparent strain of the gage are calculated assuming a constant gage factor of 1.4.

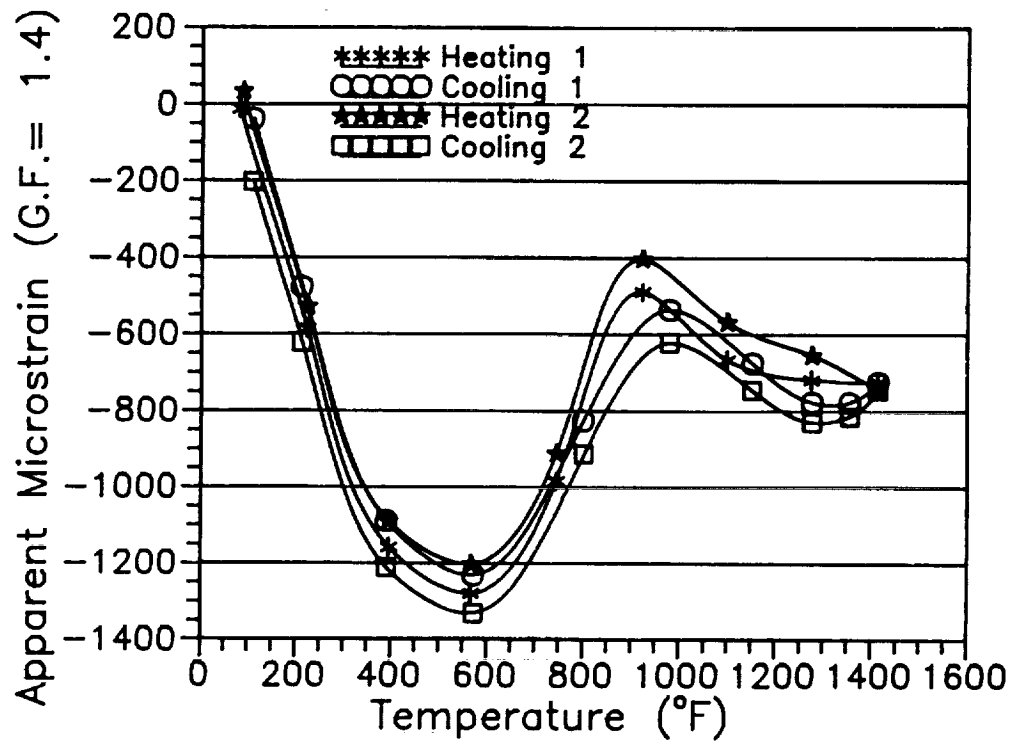
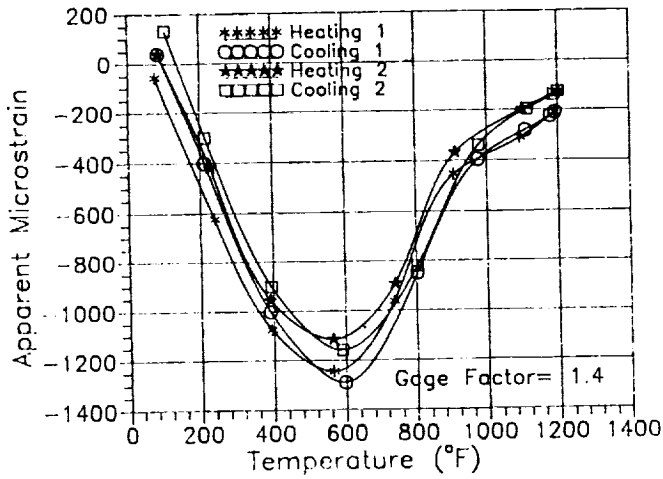
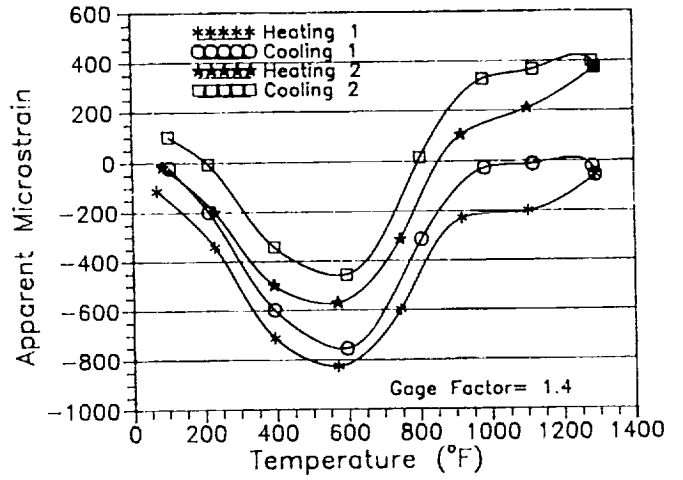

Fig. 9. Apparent strain vs temperature curves of a weldable wire gage during two thermal cycles to 1450°F. The gage is welded on an IN100 coupon.



(a)



(b)

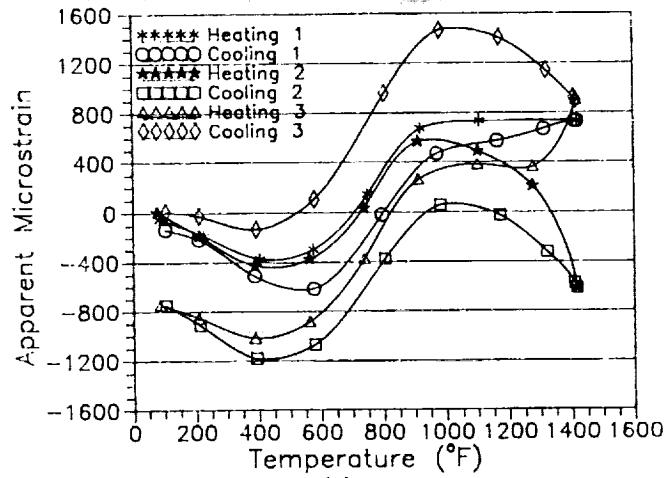

(c)

Fig. 10. Apparent strain vs temperature characteristics of a weldable wire gage during (a) two thermal cycles to 1200°F, (b) two thermal cycles to 1300°F and (c) three thermal cycles to 1420°F. The gage is welded on a 0.025" thick TMC coupon.

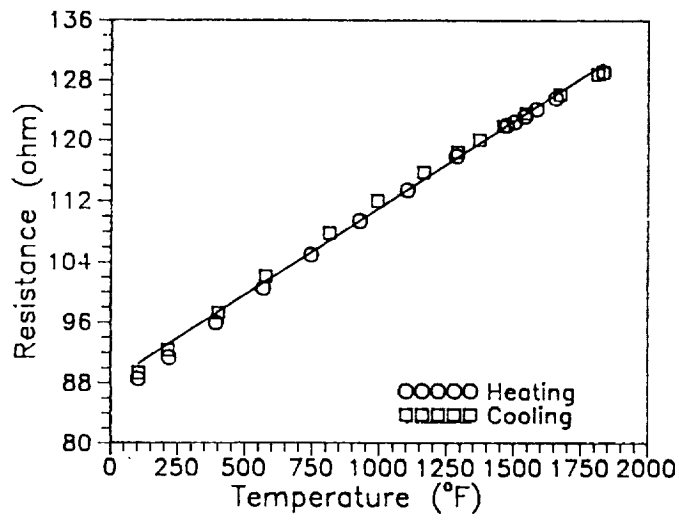

(a)

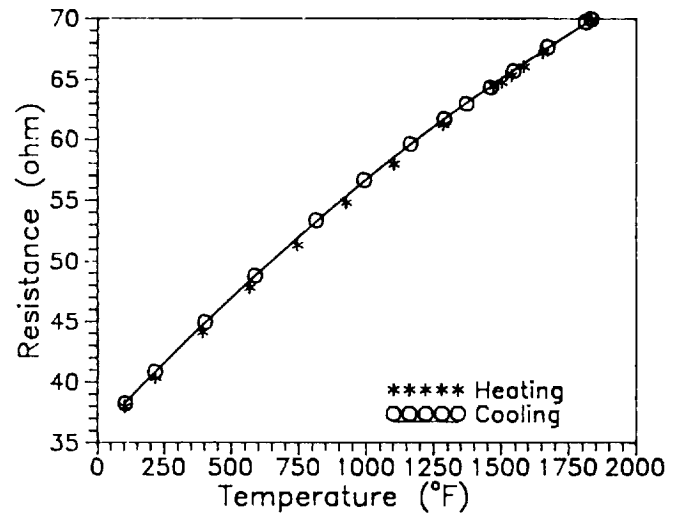

(b)

Fig. 11. Resistance vs temperature curves for the (a) effective gage $R_C^* (=R_C + r_{lg})$ and the (b) effective compensator $R_C^* (=R_C + r_{lc})$ of a thin film gage during the pre-calibration process.

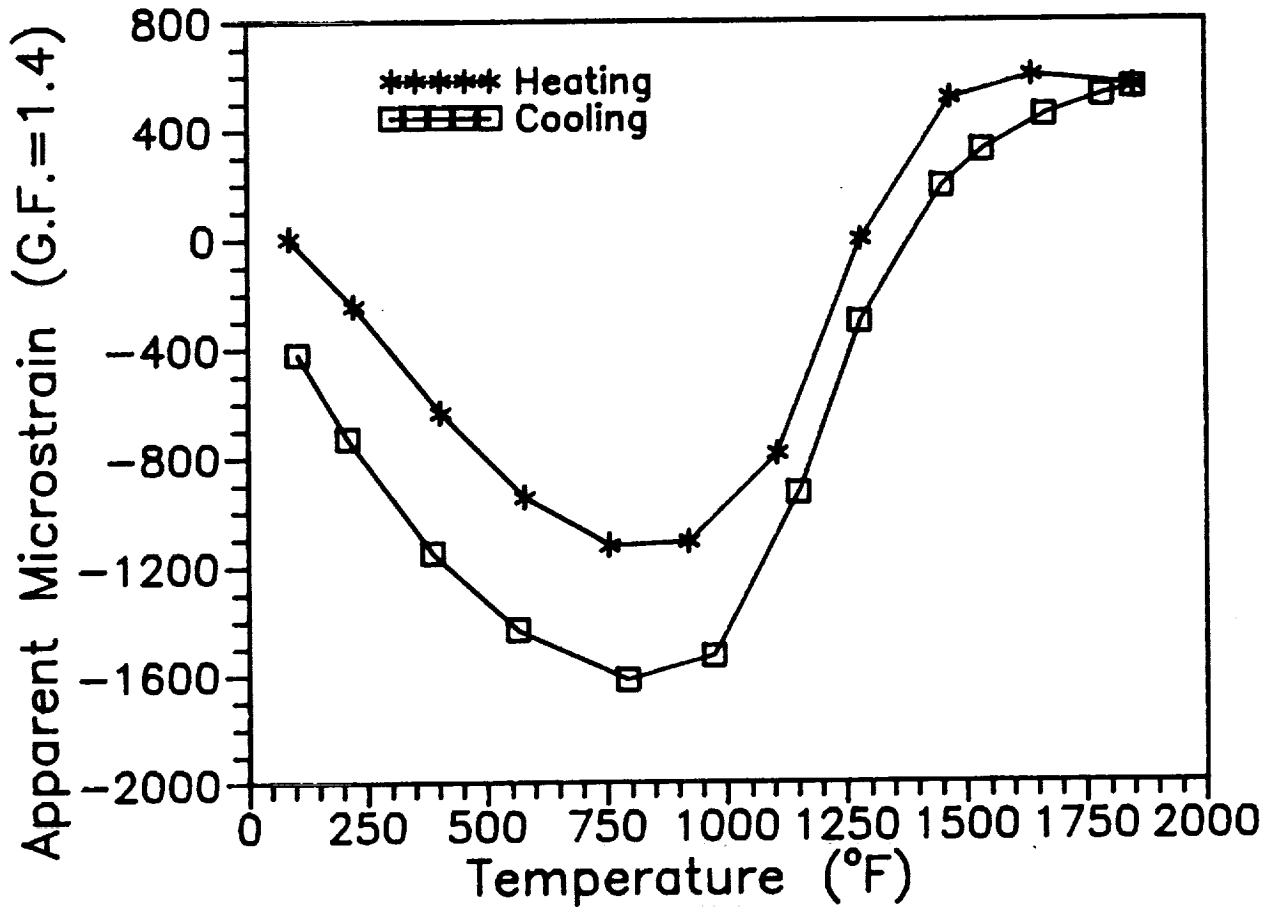

Fig. 12. Apparent strain vs temperature characteristics of a thin film gage during heat-up and cool-down cycles to 1850°F. The gage is fabricated on an alumina cantilever beam. Values of apparent strain of the gage are calculated assuming a constant gage factor of 1.4.

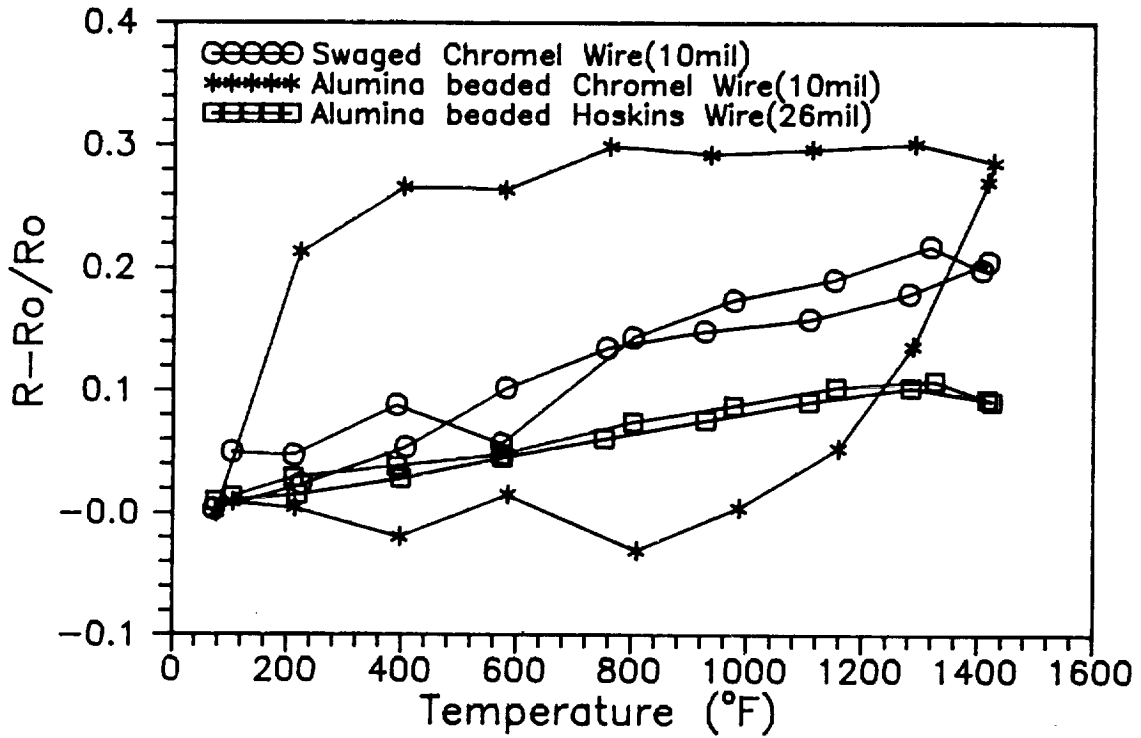

Fig. A1. The change in resistance vs temperature of various lead wires (3mil PdCr gage lead wire with various extended lead wires). Swaged chromel wire has a better oxidation resistance than the alumina beaded chromel wire.

PRECALIBRATION PROCESS

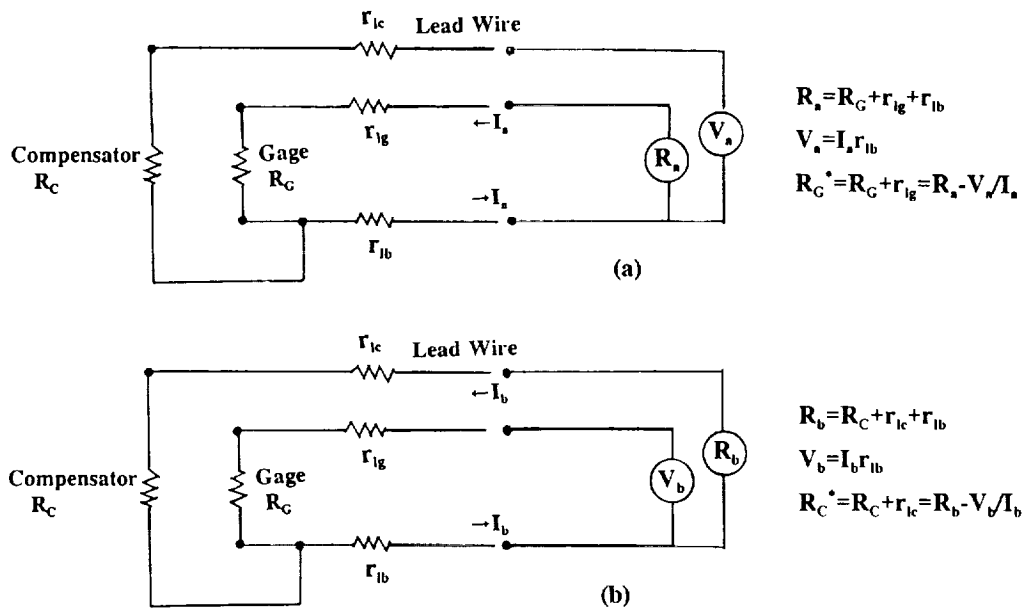

Fig. B1. The electrical circuits used in the pre-calibration process.

