

AUTOMATION AND ROBOTICS N 9 3 - 1 4 0 0 6 CONSIDERATIONS FOR A LUNAR BASE

**Nancy E. Sliwa¹, F. Wallace Harrison Jr.,
Donald I. Soloway, William S. McKinney Jr.²,
and Karin Cornils**

*MS 152D
Automation Technology Branch
NASA Langley Research Center
Hampton VA 23665-5225*

William R. Doggett and Eric G. Cooper

*Planning Research Corporation
Hampton VA 23665*

Thomas E. Alberts

*Computer and Electrical Engineering Department
Old Dominion University
Norfolk VA 23539-0496*

INTRODUCTION

The development and use of advanced automation techniques can greatly enhance and, to some degree, enable the establishment of a permanent lunar outpost. This automation is currently classed in two groups by NASA's Office of Aeronautics and Space Technology (OAST): telerobotics, which is the remote computer-assisted manipulation of equipment and materials, and systems autonomy, which includes intelligent automated control, monitoring, and diagnosis. OAST is currently providing approximately \$25M/year for the development and demonstration of telerobotic and system autonomy technology for NASA missions. This technology is being prepared for integration into current mainstream NASA operations including shuttle launch processing and mission control, the space station, and unmanned planetary mission control, so it can be assumed that much of this technology will be acceptable for use on the lunar surface.

An envisioned lunar outpost shares with other NASA missions many of the same criteria that have prompted the development of intelligent automation techniques with NASA. Because of increased radiation hazards, crew surface activities will probably be even more restricted than current extravehicular activity in low Earth orbit. Crew availability for routine and repetitive tasks will be at least as limited as that envisioned for the space station, particularly in the early phases of lunar development. Certain tasks are better suited to the untiring watchfulness of computers, such as the monitoring and diagnosis of multiple complex systems, and the perception and analysis of slowly developing faults in such systems. In addition, mounting costs and constrained budgets require that human resource requirements for ground control be minimized.

Activities on the lunar surface will require that automated systems deal with more uncertainty in their environment than will likely be found in preceding NASA missions. This uncertainty results from two sources: inability to precisely specify the working environment and decreasing precision in the hardware of the automated mechanisms from wear and exposure to the unfriendly lunar environment. A higher level of intelligence is required in the automated systems to successfully deal with this greater uncertainty.

A lunar outpost offers even more opportunities than earlier NASA missions for advancing the development of intelligent automated systems. A lunar base would offer more systems that are not life-critical, possibly allowing the expanded use of advanced automation techniques. That is, since many science, material processing, and other activities will be physically and mechanically remote from crew quarters, activity in these systems would not be as sensitive to crew safety concerns as in missions such as the space station. These systems would thus be excellent candidates for trial deployment of contemporary automation techniques, serving as testbeds for new technology. In addition, although many tasks of a lunar base are amenable to hard automation, it will not be feasible to provide a task-specific device for each. Flexible approaches to automation are required, in which a small set of adaptable devices can perform a wide range of tasks.

Much of the automation and robotic (A&R) technology necessary for a lunar base is expected to be available to NASA as a result of the space station A&R development and operations. However, all these technologies will require some degree of growth to accommodate the lunar environment, and certain specific problems will require unique solutions. The objective of this paper is to provide a glimpse of certain lunar base tasks as seen through the lens of A&R considerations. This can allow a more efficient focusing of research and development not only in A&R, but also in those technologies that will depend on A&R in the lunar environment. The goal is to make specific recommendations for designing lunar A&R systems and for areas of research focus.

¹Now at NASA Ames Research Center, Moffett Field CA 94035

²Now at Draper Labs, Cambridge MA

A number of tasks that are expected to require A&R in a lunar base environment were considered. Estimates were made of the weight, volume, speed, and range requirements of the vehicle's mobility; the size, weight, and precision requirements of the parts handling; and the expected duration and frequency of these tasks. Using these tasks as realistic examples, certain general recommendations were determined for lunar A&R systems, and a hypothetical set of systems was developed for the considered tasks.

TASK ANALYSIS

Certain tasks that are expected to be necessary on a lunar base, and that are expected to require A&R technology, were provided to the Automation Technology Branch by the Langley Spacecraft Analysis Branch, based on their investigations of thermal, environmental, and transportation requirements for a lunar base. Each of these tasks could be accomplished in a variety of ways; many approaches might seem logical from an A&R viewpoint, but may not be suitable given certain other mission restrictions that are currently known. The optimal approach for each task must be determined by integrating A&R considerations with all other mission constraints. However, baseline approaches for each task were estimated as described below.

Soil mining, transportation, processing, and storage activities associated with liquid oxygen (LOX) production. It is assumed that the processing and storage activities will be accomplished with hard automation and the soil mining and transportation activities will be accomplished with intelligent automated vehicles. As a baseline approach, we accepted the assumption of a central mining vehicle serviced by several soil transportation vehicles. The mining operation will likely require a short-range mobile vehicle with some type of large, heavy, coarse-precision gathering capability. The soil transportation vehicles could be moderate-size and -range mobile vehicles with a mechanized soil hod; no manipulation would be necessary for the transportation vehicles. This is expected to be a continuous, long-duration activity.

Soil movement activities for site preparation and habitation (hab) module protection. Large-scale soil movement will be required for grading "roads" on the Moon, which would simplify both crew and autonomous vehicle movement between facilities. Additionally, hab modules will likely be covered with lunar soil as a barrier to radiation. Road grading requires large size and weight handling capabilities over a long range with only coarse precision. Module burying is similar but with only short-range requirements. Both these activities will be infrequent but intense, with most of it occurring at the initial establishment of the outpost and at specific intervals of expansion.

Hab module handling, transportation, and interconnection. This activity would require very large part-size/weight handling (if space station hab modules are used), with moderate precision. This activity will also be infrequent but intense, with most work of this type occurring at the initial establishment of the base and at specific intervals of expansion.

Exploration and core sample retrieval. Autonomous exploration can be handled several ways. If a highly competent and robust autonomous vehicle is available, such as the Mars Rover project hopes to produce, exploration can be continuous and last indefinitely, ranging over a large portion of the local environment. At the other end of the spectrum, autonomous exploration can be very limited, directed to specific spots of interest for short-duration missions, and can be under the detailed

direction of the lunar crew or remote scientists. In either case, core sampling will require moderate size and weight capabilities over a long range, with moderate precision.

Crew/materials transportation. This would require a mobile vehicle with moderate size and weight capabilities over a long range, but probably no manipulation capabilities.

Remote experiment tending and inspection. This task is expected to require a mobile vehicle with moderate weight and size capabilities over a long range, with manipulation capabilities for light size and weight handling, with fine precision. This task is expected to be required only periodically, but for the life of the base.

Structural assembly. This is envisioned as the same type of strut-and-node assembly that will form the basis of the space station construction. Assemblies of this type will likely be built as protective covers for most of the lunar facilities. This activity would require small to moderate size and lightweight part handling over a short range, with fine precision. The duration and frequency of this activity depends on the priority of such protective covers and the rate at which new facilities are added. If protective covers are of high priority, or several new facilities are added simultaneously, this activity must be of continuous duration for a relatively short period of time. If such covers are on an as-possible basis, or if new facilities are added one at a time, gradually, then this activity can be intermittent and continue for a long time.

Solar and radiator panel installation and maintenance. This activity would require moderate size/weight part handling, with fine precision. Installation activities would be infrequent, with most of the work occurring at the initial establishment of the outpost and at specific intervals of expansion. Maintenance, repair, and replacement activities would probably be needed regularly but infrequently.

These task parameters are summarized in Table 1. The coarse estimates of the parameter values are shown in Table 2. These task scenarios and parameter values are working estimates only and are not to be taken as requirements definitions.

Note that these tasks deal primarily with external surface activities; self-contained internal automation, such as that required for attending enclosed plants and animals, maintaining crew modules, or processing specific materials, were not examined in detail. However, these activities could be expected to use specific automation technology developed for the space station or technology similar to that required for surface activities.

GENERAL TECHNOLOGY RECOMMENDATIONS

Based on these task parameter estimates and on the current state and rate of growth of required A&R technologies, general recommendations can be made for the use of certain approaches and technology to all lunar surface A&R systems.

Modularity

The first recommendation is obvious and well accepted in theory, but not generally well practiced. This is the concept of hardware and software modularity. That is, both hardware and software systems should be developed with isolatable, reusable modules. This will make maintenance of the systems much easier. Since the lunar surface is so harsh, hardware systems must be able to be regularly and easily maintained. Modules changed during

TABLE 1. Task requirement estimates.

Activities	Mobility				Manipulation				Task	
	Weight	Volume	Speed	Range	Weight	Size	Dexterity	Precision	Duration	Frequency
LOX Soil Gathering	heavy	large	slow	short	heavy	large	minimal	coarse	long	continuous
LOX Soil Transportation	moderate	moderate	moderate	moderate	heavy	large	minimal	coarse	long	continuous
Road Grading	heavy	large	slow	long	heavy	large	minimal	coarse	moderate	occasional
Hab Module Lifting	very heavy	very large	slow	short	heavy	large	minimal	coarse	short	seldom
Hab Module Transportation	very heavy	very large	slow	long	heavy	large	moderate	moderate	short	seldom
Hab Module Connection	heavy	large	slow	short	heavy	large	minimal	coarse	short	seldom
Hab Module Burying	heavy	large	slow	short	heavy	large	minimal	coarse	short	seldom
Exploration/Core Sampling	moderate	moderate	moderate	long	light	small	good	fine	long	frequent
Crew Transportation	moderate	moderate	moderate/fast	long					short	frequent
Materials Transportation	moderate	moderate	moderate	long					short	frequent
Remote Site Maintenance	moderate	moderate	moderate	long	light	small	good	fine	moderate	occasional
Structural Assembly	light	moderate	moderate	short	light	moderate	moderate	fine	moderate	occasional
Solar Panel										
Installation/Maintenance	moderate	moderate	moderate	short	light	moderate	good	fine	moderate	occasional
Radiator Pane										
Installation/Maintenance	moderate	moderate	moderate	short	moderate	moderate	good	fine	moderate	occasional

TABLE 2. Estimated parameter values.

Mobility	Manipulation	Task
Weight	Weight	Duration
Heavy: >1 ton	Heavy: >500 lb	Long: >12 hr/session
Moderate: 500 lb <×< 1 ton	Moderate: 100 lb <×< 500 lb	Moderate: 1 hr/session <×< 12 hr/session
Light: <500 lb	Light: <100 lb	Short: <1 hr/session
Volume	Size	Frequency
Large: >100 ft ³	Large: >20 ft ³	Continuous
Moderate: 20 ft <×< 100 ft ³	Moderate: 1 ft <×< 20 ft ³	Frequent: >1/day
Small: <20 ft ³	Small: <1 ft ³	Occasional: 1/day <×< 1/month
		Seldom: <1/month
Speed	Dexterity	
Fast: >10 mph	Good	
Moderate: 3 mph <×< 10 mph	Moderate	
Slow: <3 mph	Minimal	
Range	Precision	
Long: beyond local base site	Fine: <1 mm tolerance	
Moderate: within local base site	Moderate: 1 mm <×< 10 mm	
Short: <100 ft	Coarse: >10 mm tolerance	

routine maintenance could then be reconditioned, likely at the lunar base itself, for reuse. Likewise, the inevitable software maintenance will be simplified. Additionally, modularity will allow easier upgrades to accommodate new technology in both hardware and software.

Operability

The second recommendation is to provide both multimode and mixed-mode operability of the autonomous systems. Multimode operability means that a system, e.g., an autonomous vehicle, can be controlled by several different modes: (1) autonomously, (2) by an operator on site, and (3) by a remote operator, either from the crew modules or from Earth mission control. Mixed-mode operability indicates the existence of priorities and protocols to allow various control modes to work in concert. Both these mode capabilities are necessary for control of a lunar system.

In examining the need for multimode operability, consider that much of the work done by these systems will be repetitive and tedious. Additionally, there will be so many systems in simul-

taneous continuous operation that the lunar crew and Earth control will not have the resources or the desire to manually control or excessively monitor the systems. The systems must therefore be able to operate autonomously for extended periods of time.

On-site control is necessary to assist a crew member who may be on the lunar surface and have need of the system facilities, e.g., drive a vehicle somewhere other than its designated path. This mode may be critical for safety: a crew member may need to immediately override the other system control modes to protect either himself/herself or another crew member, the vehicle, materials, a facility, etc.

Remote operator control will likely be the most common alternative to autonomous control, and will be necessary to initiate, modify, or discontinue the activity of surface A&R systems. The majority of this control would come from lunar crew modules if the lunar base is manned, or from Earth control if the base is in an unmanned phase of man-tended operation. However, systems must be capable of control in either mode at any given time.

Given that multiple modes of control of a system are possible, the question is raised of which mode is in control at any given time. Mixed-mode operability deals with this question. Many situations are optimized by use of more than one mode simultaneously. For example, in manipulation tasks, the operator and computer can work concurrently, the computer doing the majority of the task, with the operator assisting at certain difficult junctures. Also, a lunar operator may request backup assistance from Earth control. However, protocols must be established to determine control mode priorities. For example, a human operator may be given priority over the autonomous mode at all times; an on-site operator may have priority over a remote operator in most circumstances.

Replication

The third recommendation is that there be maximum hardware and software replication and reuse. This means designing systems to be as similar as possible in both the software and hardware whenever multiple systems are necessary to perform a range of tasks. For example, the vehicle modules for systems to perform the "middleweight" tasks listed above could be identical, with fittings to accommodate different fixtures for different tasks: dexterous manipulator arms, a crew pod, a materials rack, a soil hod, etc. Likewise, the vehicle modules for the "heavy duty" tasks could be identical, and potentially similar to the vehicle mentioned above except on a larger scale.

Additionally, software structures and modules can be identical for many elements. For example, the operator interface may be identical for command, communication, and control of all systems. All autonomous vehicles may use the same navigation modules. Likewise, the internal software for self-monitoring and diagnosis may be structured similarly in all lunar surface systems. Besides facilitating development and maintenance, this approach would improve the crew learning and retention rate for these systems.

Although there may be an additional initial challenge in the design phase of these systems to maximize replication, this approach should significantly decrease manufacture and maintenance costs, and simplify the problem of maintaining both spare parts and expertise for maintenance. This recommendation is obviously heavily dependent on the first; replication of modules cannot be done if there is no modularity in the first place. NASA has attempted some use of system replication to decrease costs, e.g., the shuttle and the Mariner Mark II spacecraft vehicle. However, a lunar base offers an excellent chance to extend both the use of the concept and the potential savings in funds, time, and manpower.

Mechanisms

The type and form of hardware to be used for lunar systems must be the topic of much research. The severe dust problem and the continuing radiation exposure will require inventive design techniques combined with new materials to provide even a moderately reasonable level of mechanism endurance. But it is unreasonable to assume that complex mechanical systems can be made infinitely reliable for continuous operation on the Moon; systems must also be designed for easy maintenance. In early phases of the lunar base development, astronauts must be able to replace defective components and refurbish most parts themselves. In future phases, an automated "garage" can be

envisioned, where maintenance and repairs to vehicles can be automatically performed based on computerized activity logs and fault scans. Vehicles could be automatically reconfigured based on dynamic task scheduling of ongoing and future activities.

In addition to easy maintenance, maximum functional redundancy should be a part of the entire set of lunar surface systems. Ideally, there should be sufficient functional flexibility in the automated systems to allow another vehicle to cover a necessary task if the primary vehicle is temporarily indisposed. At least initially, most functional redundancy may need to be accomplished by astronaut intervention.

Within this general framework of mechanism requirements, there are open questions relating to the best modes of transportation (wheeled, tracked, legged, suspended) for different systems and the manipulation requirements (how many arms, how many degrees of freedom, what size work envelope, etc.) of several different tasks. High-precision manipulation from a mobile platform, particularly in a low-gravity environment, must receive research attention. This type of mission analysis will require special simulation tools.

Sensors

Sensors are what make possible any significant degree of intelligent automation. Given the high degree of uncertainty in the lunar environment, tasks cannot expect to be fixtured and hard-automated as they currently are on the factory floor. Sensors allow automated systems to adapt to their uncertain and ever-changing environment and are an essential element for intelligent manipulation systems. Force/torque sensing and laser sensing will be very important to lunar surface systems; vision may be less important due to difficulties in adapting to lighting situations and speed requirements, though it will still be useful for providing essential operator information. Other less obvious sensors may be used very effectively on the lunar surface; e.g., "autonomous" navigation along routine paths could be achieved by using special beacons posted periodically along the desired path, with sensors on the vehicles designed specifically to detect the navigation signals.

Sensors within the mechanisms of automated systems are also essential to the diagnosability of faults in those systems. It will be essential to ensure that lunar systems are designed with sufficient sensor information available to allow fault isolation for repair.

Fault Detection and Recovery

Computers are well suited to the task of tirelessly watching for infrequent or slowly developing faults and for remembering the correct diagnosis and recovery sequences, even for rarely occurring problems. Humans are very poor at this type of task. Artificial intelligence has made major advances in the field of modeling and diagnosing sophisticated systems, making it possible to plan on the widespread use of this technology for lunar base systems. Such systems should be able to autonomously monitor all activity, diagnose failures, and recommend and/or perform recovery operations, allowing fault-scaled operations until full-scale repair can be performed, if necessary. Additionally, these systems should be able to monitor long-term performance, detect slowly developing problems, and recommend maintenance and repair activities to avoid future failure.

Design Knowledge Capture

Design knowledge capture (DKC) refers to the computerized maintenance of an "audit trail" for a system (both hardware and software) that records initial design, design changes, prototype development, bugs and fixes, production data and anomalies, and maintenance and repair; in other words, the life history of a particular system. This information is then available to facilitate maintenance and upgrades.

This technology has been designated by NASA as critical to many future missions. This technology is also of great interest to DoD and to commercial industry, particularly the auto industry. It is reasonable to assume that NASA can use components of this technology that will be developed by others, and extend the state-of-the-art in this technology with new applications and more stringent requirements, particularly for integration with other system components.

Computational Reliability

All the above recommendations assume that there will be sufficient sophisticated computing capability on board lunar surface systems. NASA and DoD currently have a major program for developing spaceborne multiprocessing and symbolic computers. Priority must be given to extending this capability for systems using multiple interacting processors, and to making the processor rugged enough for lunar surface travel.

The usefulness of computerized systems in the lunar environment will be directly proportional to the reliability of the processors and the software running in them. NASA Langley is currently seeking to improve the reliability-to-cost ratio of the validation and verification (V&V) of conventional systems. Additionally, NASA's AI community has given very high priority to mission-qualification techniques for knowledge-based systems. Research in this area needs to cover the broad spectrum of V&V, as well as field testing and acceptance procedures for knowledge-bases systems. This will include elements of completeness checking, safety and sensitivity analyses, and static and dynamic consistency tests.

VEHICLE SET

Given a task set and the above general recommendations, a hypothetical set of devices can be formulated for lunar surface work.

A key component of this set must be the mobility modules. One reasonable approach would be to provide two or three sizes of mobility modules: "smart platforms" (Fig. 1). A platform would include some standard set of actuators and sensors, a navigation module, an operator interface, a system executive, etc. At least a large platform (Fig. 1a) and a medium-sized platform (Fig. 1b) would be needed to accommodate the different tasks. These platforms would be identical in all but size.

Another approach is to use much smaller standard components, "smart wheels" (Fig. 2a), that can then be joined in series (Fig. 2b) and/or parallel (Fig. 2c) to create the size of platform needed for any particular task. This is a more intriguing but more complex approach, and would require significant advances in distributed system integration, control, and cooperation. However, this approach might ease logistics problems: small modules would be easier to pack and transport, and would allow at least some work

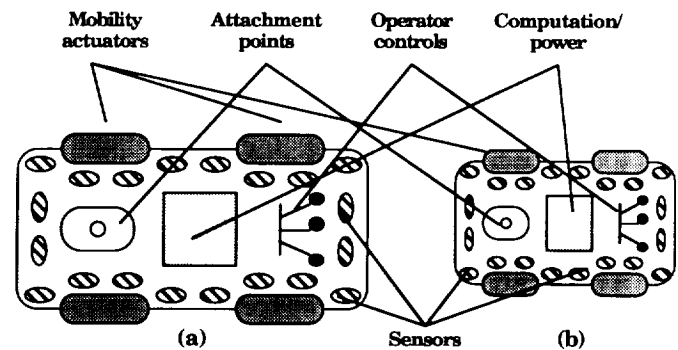

Fig. 1. Stylized renditions of the "smart platform" concept (top view).

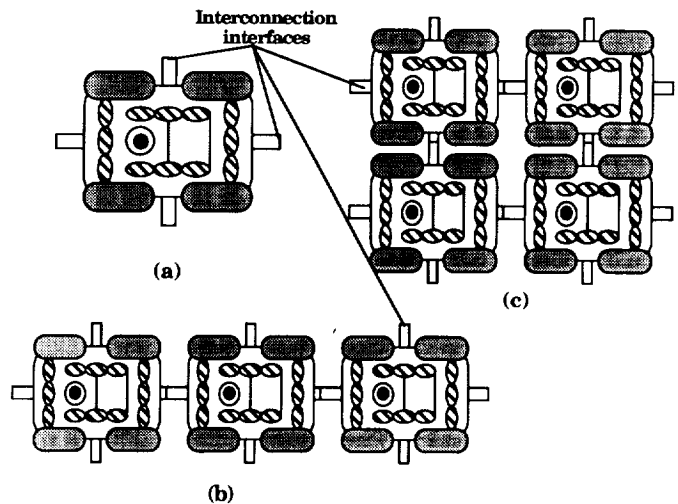

Fig. 2. Stylized renditions of the "smart wheels" concept (top view).

to be done with a small number of "smart wheels." Heavier-duty capabilities could be added incrementally as more of these modules are brought in subsequent flights.

Given some standard mobility platforms, attachments can then be interchanged to adapt the platform to a variety of tasks. For example, a soil hod attached to a medium-sized platform could transport soil in mining operations. Manipulators on the same platform could do structural assembly and maintenance operations. Other attachments could adapt it to crew and material transportation.

Likewise, a large platform could accept attachments for soil mining, road grading, and large object lifting. It is possible that one attachment can perform several tasks.

It will also frequently be necessary to use more than one vehicle for any given task. For example, if a vehicle with manipulators is to perform a radiation panel installation task, the same vehicle should not be expected to be designed to carry radiation panels; a general-purpose materials-carrying vehicle should accompany the manipulator vehicle to the task site. Likewise, a vehicle for lifting heavy objects like hab modules may not have to carry them long distances; it may transfer its burden to a "train" of smaller vehicles for transportation.

AUTOMATION AND ROBOTICS PHILOSOPHY

It is also necessary to examine other scenarios for transportation requirements. For example, future phases of a lunar base could make extensive use of tunneling, as well as cable- or rail-driven vehicles. Anticipation of such future approaches could change the initial optimal A&R approach.

Even in the early phase of a base, suspended cable-driven apparatus may provide a very logical approach to many transportation needs. It takes advantage of the low lunar gravity, requires minimal equipment to be transported from Earth, is of relatively low complexity, and would be easy for astronauts to set up and reroute. Although this may seem like a low-automation approach to be advocating in this paper, it provides an opportunity to express a philosophy about an approach to lunar base automation. *A&R solutions to lunar base problems should be allowed to fill their proper niche at the proper time.* Properly applied, A&R can provide significant advantages: decreased costs, increased safety,

and evolutionary development. Improperly applied, A&R can reverse these benefits, and saddle NASA with very costly yet unreliable and quickly antiquated systems.

The key to reaping the benefits of A&R lies in two areas: (1) focused research in A&R and supporting technologies, as listed above, and (2) a multidisciplinary approach to developing system requirements. A&R specialists cannot develop realistic systems based solely on sketchy knowledge of current and future mission constraints; likewise, A&R approaches cannot be developed, analyzed, and accepted or discarded without substantial knowledge of the many intricacies of the field. It is necessary to bring these two important elements, mission knowledge and A&R knowledge, together in a truly cooperative venture.

Acknowledgments. Our thanks to the Spacecraft Analysis Branch at NASA Langley Research Center, and to the Advanced Programs Office of NASA Johnson Space Center, for the information they have provided in support of this effort.