

---

# Reusable Reentry Satellite (RRS) Summary Report

---

## Thermal Control Trade Study

(NASA-CR-186528) REUSABLE REENTRY  
SATELLITE (RRS): THERMAL CONTROL  
TRADE STUDY Summary Report  
(Science Applications International  
Corp.) 44 p

N93-16719

Unclas

April 1990

G3/18 0277562

Contract NAS9-18202  
DRL 02

Prepared for:

National Aeronautics and Space Administration  
Lyndon B. Johnson Space Center  
Houston, Texas 77058



**Science Applications International Corporation**

21151 Western Avenue • Torrance, California 90501 • (213) 781-9022

---

# ***Reusable Reentry Satellite (RRS) Summary Report***

---

## **Thermal Control Trade Study**

**April 1990**

**Contract NAS9-18202  
DRL 02**

Prepared for:

**National Aeronautics and Space Administration  
Lyndon B. Johnson Space Center  
Houston, Texas 77058**

---



***Science Applications International Corporation***

**21151 Western Avenue • Torrance, California 90501 • (213) 781-9022**

## FOREWORD

The Reusable Reentry Satellite (RRS) Thermal Control Subsystem (TCS) Trade Study described herein was performed during Part 1 of the RRS Phase B contract. This report is one of several that describes the results of various trade studies performed to arrive at a recommended design for the RRS satellite system. The overall RRS Phase B Study objective is to design a relatively inexpensive satellite to access space for extended periods of time, with eventual recovery of experiments on Earth. The RRS will be capable of: 1) being launched by a variety of expendable launch vehicles, 2) operating in low-earth orbit as a free flying unmanned laboratory, and 3) executing an independent atmospheric reentry and soft landing. The RRS will be designed to be refurbished and reused up to three times a year for a period of 10 years. The expected principal use for such a system is research on the effects of variable gravity (0-1.5 g) and radiation on small animals, plants, lower life forms, tissue samples, and materials processes.

This summary report documents the work performed by Science Applications International Corporation (SAIC) in the assessment and design of the TCSs necessary to maintain the temperatures of applicable reusable reentry satellite hardware within prescribed limits during on-orbit operations. Specifically, this report describes the efforts to define and verify TCS designs for maintaining the satellite's Payload Module (PM) environmental control system heat exchanger, propellant, and water supply within required temperature limits.

The study was performed under the contract technical direction of Mr. Robert Curtis, SAIC Program Manager. The analyses described herein were performed by Mr. Clark Wallace, SAIC-Torrance, Thermal Sciences Division. Mr. Michael Richardson, JSC New Initiatives Office, provided the RRS objectives and policy guidance for the performance of this study under the NAS 9-18202 contract.

# CONTENTS

Section	Page
Foreword.....	i
Table of Contents.....	ii
List of Figures.....	iii
List of Tables.....	iv
List of Abbreviations and Acronyms.....	v
Executive Summary.....	vi
1.0 INTRODUCTION.....	1
1.1 Background.....	1
1.2 NASA JSC Statement of Work Task Definition.....	1
1.3 Scope.....	3
2.0 STUDY APPROACH.....	3
2.1 Organization.....	3
2.2 Document Format.....	3
3.0 PURPOSE.....	4
4.0 GROUND RULES AND ASSUMPTIONS.....	4
5.0 PAYLOAD MODULE ECLSS HEAT EXCHANGER THERMAL CONTROL SUBSYSTEM.....	5
5.1 Introduction.....	5
5.2 Modeling Tool.....	10
5.3 Model.....	10
5.5 Assumptions.....	13
5.6 Results.....	14
5.7 Conclusions.....	21
6.0 EXTENDED MODULE PROPELLANT THERMAL RESPONSE.....	21
6.1 Introduction.....	21
6.2 Modeling Tool.....	22
6.3 Model.....	22
6.4 Assumptions.....	27
6.5 Results.....	28
6.6 Conclusions.....	29
7.0 PAYLOAD MODULE WATER SUPPLY THERMAL RESPONSE.....	34
8.0 REFERENCES.....	36

## LIST OF FIGURES

Figure		Page
5-1	DRM-3 Orbital Geometry and RRS Vehicle Orientation Considered in Forward Module Aft Cover and Aeroshell Surface Heat Balance Calculations...	7
5-2	Net Heat Flux on Aft Cover and Aeroshell (180° Conic Station) for DRM-3, Vernal/Autumnal Equinox, Gravity Gradient Vehicle Orientation.....	8
5-3	Payload Module ECLSS Heat Exchanger TCS Coolant Loop and Space Radiator Concept.....	9
5-4	Payload Module ECLSS Heat Exchanger Thermal Control Subsystem.....	9
5-5	Subdivision of Aeroshell Radiator Into 12 Equivalent Panels.....	11
5-6	Detail of Aeroshell Radiator Panel Model.....	12
5-7	ECLSS Heat Exchanger TCS Coolant Loop Fluid Network Model.....	12
5-8	ECLSS Heat Exchanger TCS Pump Characteristic Curve.....	14
5-9	Orbital Geometry and Vehicle Orientation and Rotation Modes Considered in Total Absorbed Flux Computations.....	15
5-10	Total Absorbed Flux (Solar + Albedo + Earth IR) at Radiator Panel 1 Surface During One Orbital Period for DRM-3, Vernal/Autumnal Equinox and DRM-5, Summer Solstice With Vehicle Normal and Axial Rotation Rates of 7.0 and 0.14 rpm, Respectively.....	17
5-11	Fluid Network Hydraulic Response.....	18
5-12	Coolant Thermal Response.....	18
5-13	Aeroshell Surface and Coolant Thermal Response, DRM-3 and DRM-5.....	20
6-1	RRS Extended Module Model.....	23
6-2	DRM-3 Orbital Geometry and RRS Vehicle Orientation Considered in Extended Module Solar Array Thermal Response Analysis.....	24
6-3	Extended Module Solar Array Thermal Response for DRM-3 Orbit.....	25
6-4	Extended Module Solar Array Thermal Response for DRM-3 Orbit With and Axial Rotation of 0.14 rpm.....	25
6-5	Extended Module Model Electrical Network Analog.....	26
6-6	Total Absorbed Flux (Solar + Albedo + Earth IR) at Extended Module Aft Cover Surface During One Orbital Period for DRM-3, Vernal/Autumnal Equinox, Normal Rotation and Gravity Gradient Vehicle Orientations.....	30
6-7	Total Absorbed Flux (Solar + Albedo + Earth IR) at Extended Module Aft Cover Surface During One Orbital Period for DRM-5, Summer Solstice, Normal Rotation and Gravity Gradient Vehicle Orientations.....	31
6-8	Predicted Temperature Response of Extended Module for DRM-3, Vernal/Autumnal Equinox, Normal Rotation and Gravity Gradient Vehicle Orientations.....	32
6-9	Predicted Temperature Response of Extended Module for DRM-5, Summer Solstice, Normal Rotation and Gravity Gradient Vehicle Orientations.....	33
7-1	Water Storage Tank Locations Within Forward Module.....	34

## LIST OF TABLES

Table		Page
4-1	RRS Design Reference Missions.....	4
5-1	ECLSS Heat Exchanger TCS Coolant Loop Fluid Network Components.....	13
5-2	DRM-3, Vernal/Autumnal Equinox and DRM-5, Summer Solstice Orbit Definitions.....	16
5-3	PM ECLSS TCS Weight Budget.....	19
6-1	Extended Module Model Electrical Network Analog Nodal Descriptions.....	27

## LIST OF ABBREVIATIONS AND ACRONYMS

DRM	Design Reference Mission
ESM	Silicone Elastomer
HYSTAM	Hypersonic-Vehicle Structural, Thermal, and Acoustic Management
IR	Infrared
NASA	National Aeronautics and Space Administration
PM	Payload Module
RRS	Reusable Reentry Satellite
SAIC	Science Applications International Corporation
SRD	System Requirements Document
TASC	Thermal Analyzer for Systems Components
TCS	Thermal Control Subsystem

## EXECUTIVE SUMMARY

This report documents the design and assessment work performed in defining the on-orbit TCS requirements for the RRS. Specifically, it describes the hardware and design measures necessary for maintaining the PM Environmental Control Life Support System (ECLSS) heat exchanger, the hydrazine propellant, and PM water supply within their required temperature limits.

A review of the Ames RRS design study and a preliminary evaluation of the SAIC RRS configuration indicated that a liquid coolant loop in conjunction with a space radiator, was a viable thermal control concept for the ECLSS heat exchanger. Ethylene glycol was identified as an appropriate coolant and the vehicle aeroshell was determined to have sufficient radiative capacity for dissipating the anticipated PM heat load.

A thermal-fluid response assessment of the fluid network and radiator was performed considering the proposed RRS orbits and vehicle orientations that subjected the aeroshell to the most thermally stressing environments. The analysis indicated that eight, 0.889 diameter coolant tubes, in conjunction with a coating of low absorptivity, high emissivity white paint on the aeroshell's surface, were adequate space radiator design measures for effectively cooling the ECLSS heat exchanger. The estimated power requirement for the subsystem is a continuous 7.4 watts and the projected mass is 38.4 lbs (17.4 kg).

A conservative assessment of the on-orbit thermal response of the RRS extended module indicated that the propellant housed within its interior should remain between 280 and 295 K for all anticipated RRS missions. Shielding the propellant tanks from direct extraterrestrial exposure and coating the exterior surfaces of the module's forward and aft covers with a high absorptivity black paint will maintain the propellant above its minimum allowable of 275 K. The thermal assessment of the extended module also indicated that an 0.14 rps vehicle axial rotation is necessary to alleviate excessive cell temperatures experienced by the module's exterior solar array. The rotation induces accelerations below the maximum allowable of  $10^{-5}$  g.

The PM water supply tanks will experience radiant exchange primarily with the inner surface of the aeroshell substructure and the external surface of the PM cannister. Since the temperatures of these surfaces will fall between 281 and 291 K, which is above the 273 K minimum allowable, it was concluded that no active heating of the water will be necessary.



## **1.0 INTRODUCTION**

### **1.1 Background**

As currently conceived, the RRS will be designed to provide investigators, in several biological disciplines, with a relatively inexpensive method to access space for up to 60 days with eventual recovery on Earth. The RRS will be designed to permit totally intact, relatively soft, recovery of the vehicle, system refurbishment, and reflight with new and varied payloads. The RRS system will be capable of three reflights per year over a 10-year program lifetime. The RRS vehicle will have a large and readily accessible volume near the vehicle center of gravity for the PM containing the experiment hardware. The vehicle is configured to permit the experimenter late access to the PM prior to launch and rapid access following recovery.

The RRS will operate as a free-flying spacecraft in orbit and be allowed to drift in attitude to provide an acceleration environment of less than  $10^{-5}$  g. The acceleration environment during orbital trim maneuvers will be less than  $10^{-3}$  g. The RRS is also configured to spin at controlled rates to provide an artificial gravity of up to 1.5 Earth g. The RRS system will be designed to be rugged, easily maintained, and economically refurbishable for the next flight. Some systems may be designed to be replaced rather than refurbished if cost effective and capable of meeting the specified turnaround time. The minimum time between recovery and reflight will be approximately 60 days. The PMs will be designed to be relatively autonomous with experiments that require few commands and limited telemetry. Mass storage, if needed, will be accommodated in the PM. The hardware development and implementation phase is expected to begin in 1991 with a first launch in 1993.

Numerous trade studies and RRS functional design descriptions are required to define a viable RRS concept that satisfies the requirements. The National Aeronautic and Space Administration (NASA) has contracted with SAIC to perform a Phase B study to provide the RRS concept definition. The Thermal Control Trade Study described in this report is one of the supporting study analyses performed by the SAIC Team.

### **1.2 NASA JSC Statement of Work Task Definition**

The TCS trade study was performed per the general direction of the RRS Statement of Work and the System Requirements Document (SRD) as given in the following paragraphs:

**General:**

SOW Paragraph 3.1.2.7 RRS Thermal Control System - Conduct tradeoff studies related to the choice and characteristics of the thermal control system for the RRS (and associated rodent module (RM) and other modules).

- (a) Examine thermal control concepts of the RRS vehicle subsystems and the RM and other modules through appropriate ground support equipment (GSE) during integration to the RRS vehicle, integration of the RRS system to the launch vehicle, and pre-launch preparations.
- (b) Examine thermal control concepts of the RRS system and the RM and other modules during the launch ascent trajectory, orbital flight (both drifting at less than  $10^{-5}$  g and spun about the longitudinal axis for artificial gravity), the deorbit exoatmospheric trajectory, atmospheric flight to landing, the post-landing period prior to the attachment of GSE, and the post-landing period prior to demating of the experiment payload.

**Specific:**

SRD Paragraph 3.3.5 Thermal Control Subsystem

**3.3.5.1 RRS Subsystems.** The RRS Thermal Control Subsystem shall maintain the temperature of all RRS subsystem within their required nonoperating and operating temperature ranges throughout all mission phases.

**3.3.5.2 PM.** The RRS Thermal Control Subsystem shall provide the appropriate thermal control at the RRS/PM thermal interfaces to satisfy the PM thermal requirements (TBD) for all phases of a mission.

**3.3.5.3 Pre-Launch Phase.** The RRS will be maintained at the desired temperature range by use of GSE connected to the internal RRS cooling system. The GSE shall not impede late access to the PM.

**3.3.5.4 Orbit Phase.** The RRS cooling system shall be designed to remove the maximum payload heat rate, TBD, for orbit conditions from sun-synchronous orbit to low-inclination orbits, plus a reasonable margin for growth.

**3.3.5.5 Recovery Phase.** The RRS Thermal Control Subsystem shall be designed to minimize the reentry heat soak into the internal cavity of the vehicle and to minimize the increased RRS PM temperature. The design shall allow thermal control via GSE to be applied to the PM within TBD minutes of ground touchdown.

### **1.3 Scope**

This NASA Phase B study is intended to provide definition of the RRS concept. The study includes tradeoff studies with the depth of analysis as appropriate to clarify and document the viability of each approach. The RRS system and operations are developed to the degree necessary to provide a complete description of the designs and functional specifications. The TCS trade described in this report was performed to ensure that the SAIC RRS design meets all mission requirements, yet remains as simple and cost-effective as possible.

## **2.0 STUDY APPROACH**

### **2.1 Organization**

The tradeoff analyses performed in Part 1 of the RRS Phase B study were organized to be accomplished in a series of related, but separate, tradeoff studies and system concept definitions. Therefore, the documentation described in these summary reports has been formatted to accommodate a compendium of analyses that are published in several separate documents. Because of the synergistic nature of one tradeoff study across the entire RRS system design, it is suggested that the reader review all summary reports to get a complete picture of the SAIC RRS design.

### **2.2 Document Format**

Individual analyses and studies are not necessarily amenable to documentation in exactly the same topical arrangement; however, a general outline has been used where reasonable for all reports. The guideline for preparing the individual study sections in this and all summary reports is provided below:

- Purpose
- Groundrules and Assumptions
- Analysis Description

- Analysis Results
- Conclusions
- Recommendations

### 3.0 PURPOSE

The purpose of the RRS Thermal Control Trade Study was to assess the design of the TCSs necessary to maintain the temperatures of applicable RRS hardware within prescribed limits during on-orbit operations. Specifically, this report describes the efforts to define and verify TCS designs for maintaining the satellite's PM environmental control system heat exchanger, propellant, and water supply within required temperature limits.

### 4.0 GROUND RULES AND ASSUMPTIONS

The overall requirements of the RRS TCS were discussed previously in Section 1.2 as stated in the RRS SRD. These requirements and the design reference missions (DRMs) defined early in the study, and shown in Table 4-1, were the only top-level groundrules and assumptions used in the thermal trade system studies.

Table 4-1. RRS Design Reference Missions

Design Reference Mission Set					
Definition Parameter	DRM-1	DRM-2	DRM-3	DRM-4	DRM-5
Character	Land Recovery	High Altitude	High Inclination	Integer Orbits	Water Recovery
Inclination	33.83°	33.83°	98°	35.65°	28.5°
Orbit Type	Circular	Circular	Circular, Near-Integer	Circular, Integer	Circular
Orbit Altitude	350 km (189 nm)	900 km (486 nm)	897 km (484 nm)	479 km (259 nm)	350 km (189 nm)
Launch Site	Eastern Test Range (ETR)	ETR	WTR	ETR	ETR
Recovery Site	White Sands Missile Range (WSMR)	WSMR	WSMR	WSMR	Water (ETR, Gulf of Mexico, WTR)

## 5.0 PAYLOAD MODULE ECLSS HEAT EXCHANGER THERMAL CONTROL SUBSYSTEM

### 5.1 Introduction

The RRS PM contains a complete ECLSS capable of providing the required atmosphere for sustaining 18 rodents and a suite of related electronics and hardware for up to 60 days. Within the PM, the air supply's humidity, chemical content, and temperature are monitored and adjusted continually. The humidity and content are controlled by subsystems completely internal to the PM. The temperature is maintained by regulating the flow of air through the ECLSS heat exchanger.

During satellite launch, ascent, reentry, and recovery periods, the heat exchanger functions autonomously to cool the PM airflow through the incorporation of a fusible wax within its construction. The wax undergoes a solid/liquid phase transition at 278.8 K and the quantity contained within the heat exchanger has been sized to provide 1055 kilojoules of thermal storage. This translates into approximately 3 hours of independent cooling capability. A complete description of the ECLSS heat exchanger design is provided in the SAIC RRS Payload Module Trade Study. While the satellite is in orbit, however, heat removal and consequent dissipation must be provided by a TCS coupled to the heat exchanger, but external to the PM.

The heat generated within the PM is attributable to the rodents and electronics/hardware which produce, on average, 45 and 75 watts, respectively. The external TCS must, therefore, be capable of transporting and dissipating approximately 120 W of heat. In addition, the minimum anticipated PM air temperature is 291 K which requires the TCS to maintain the PM ECLSS heat exchanger at or below this temperature.

The Ames Reusable Reentry Satellite Design Study (Ref. 1), confronted with a similar set of capability requirements, went a long way in identifying the character of a potential TCS. Two preliminary observations were instrumental in shaping the basic concept and defining their final TCS design. First, the RRS concept places maximum emphasis on the reusability of onboard subsystems and, therefore, an expendable TCS was not permissible. Secondly, the satellite's geometry, in conjunction with the transient nature of the PM heat loads, did not bode well for passive TCSs such as heat pipes. Therefore, it was concluded that an integrated, active TCS consisting of a fluid network coupled with a space radiator was the most efficient alternative. The SAIC RRS configuration is no exception to the above considerations and therefore this study

addressed the design and corresponding assessment of a fluid network/space radiator TCS concept.

To ascertain the validity of this concept in relation to the SAIC RRS vehicle design, potential locations for the required space radiator were examined. The aft cover of the forward module was considered first. This location provides approximately 1.5 square meters of relatively contiguous radiator area. However, when the vehicle is orientated to induce a microgravity environment (gravity gradient orientation - no vehicle rotation in the orbital plane - nose facing outward) the aft cover is Earth-facing over the entire orbit. Such an orientation will severely degrade this location's dissipative efficiency.

To assess the actual impact this orientation has on the aft cover's efficiency as a radiator, a heat balance calculation was performed at its surface for the DRM-3 orbit at Vernal/Autumnal Equinox. Figure 5-1 depicts the DRM-3 orbit and corresponding vehicle orientation used in the analysis. The calculation accounted for direct solar insolation, Earth-reflected solar insolation, and Earth infrared (IR) radiation as a function of the cover's time variant orbital position and orientation. Surface reradiation to the Earth ( $T_e = 289 \text{ K}$ ) and deep space were also included. The aft cover's surface was assumed to have a solar absorptance of 0.2 and a hemispherical emissivity of 0.9. The Earth albedo was set at 0.35 and the cover's surface temperature was held constant at 270 K.

The results from this heat balance calculation are presented in Figure 5-2 where the net heat flux on the aft cover's surface is plotted as a function of time. The net flux is always positive (surface is absorbing energy) and the average over the entire orbit is  $19 \text{ W/m}^2$ . Since the surface must experience an average negative net heat flux of at least  $-80 \text{ W/m}^2$  to effectively dissipate the PM heat load, the analysis indicates that the aft cover is not an acceptable location for the radiator.

Having eliminated the aft cover as a candidate location for the space radiator, the remaining alternative was to use the vehicle's aeroshell. The aeroshell provides approximately 4.4 square meters of unobstructed radiator area, excluding the aft skirt and nose of the vehicle. To verify the dissipative potential of this location, a heat balance calculation, as described above, was performed at the aeroshell's surface for the  $180^\circ$  circumferential station (see Figure 5-1).

Before the results from the above calculation are discussed, it is important to note that an assessment of the extended module's on orbit thermal response (Section 6.0) indicated that a vehicle axial rotation rate of 0.14 rpm was necessary (see Figure 5-1). This requirement was

imposed to alleviate the the excessive temperatures experienced by the sun-facing portion of the module's solar array that resulted in a significant degradation in cell power production efficiency. Polar orbits, such as DRM-3, in conjunction with the microgravity vehicle orientation (no rotation in the orbital plane) resulted in the most severe temperature excursions. An axial rotation rate of 0.14 rpm was found to effectively smooth the highly nonuniform heating about the module's circumference, consequently lowering the bulk temperature of the power producing portion of the solar array.

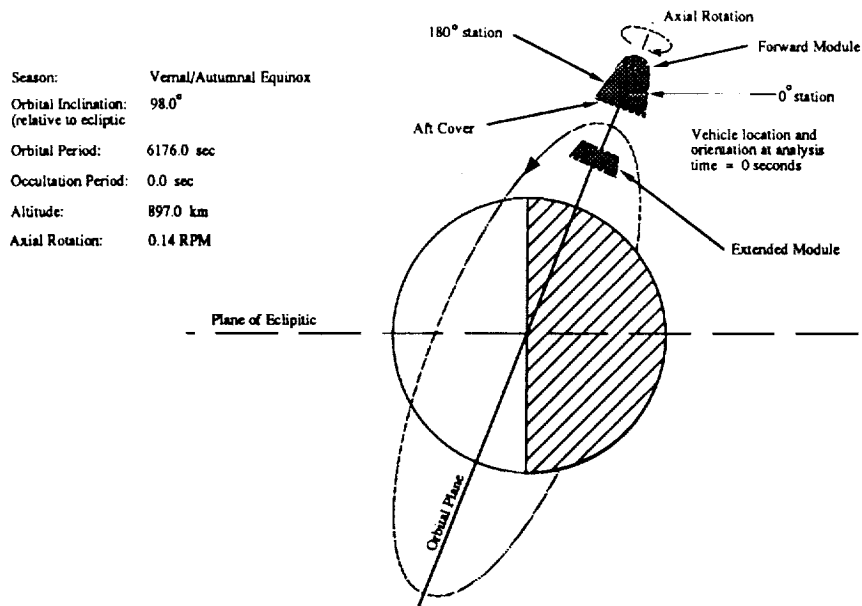

Figure 5-1. DRM-3 Orbital Geometry and RRS Vehicle Orientation Considered in Forward Module Aft Cover and Aeroshell Surface Heat Balance Calculations.

This axial rotation rate was found to induce an acceleration of  $0.8 \times 10^{-5}$  g at a radius of 35.6 cm, which is the maximum radius of the PM rodent cages. This acceleration falls below the maximum allowable level of  $10^{-5}$  g set forth in the RRS System Design Study Statement of Work, Section 4.2.5.2 (Ref. 2) and is therefore acceptable. The impact of this rotation on vehicle stability is described in the SAIC RRS Guidance, Navigation, and Control Trade Study.

Figure 5-2 shows results from the heat balance calculation at the 180° circumferential station. The periodic nature of the net heat flux is due to the vehicle's 0.14 rpm axial rotation rate. The average net heat flux over one orbit is  $-158 \text{ W/m}^2$ . This translates into almost 700 W of dissipation power for the entire aeroshell for this orbit if one assumes a construction from a thin wall, high conductivity material at a constant temperature of 270 K. Since the radiator will, in fact, consist of almost 3 centimeters of low conductivity foamed silicone elastomer (ESM), the anticipated efficiency will be much lower. Nevertheless, the above result indicates that the aeroshell is a viable location for the TCS space radiator.

DRM-3, Vernal/Autumnal Equinox, Gravity Gradient  
 $a_s = 0.2, \epsilon_H = 0.9$ , albedo = 0.35,  $T_e = 289$  K,  $T_{ref} = 270$  K

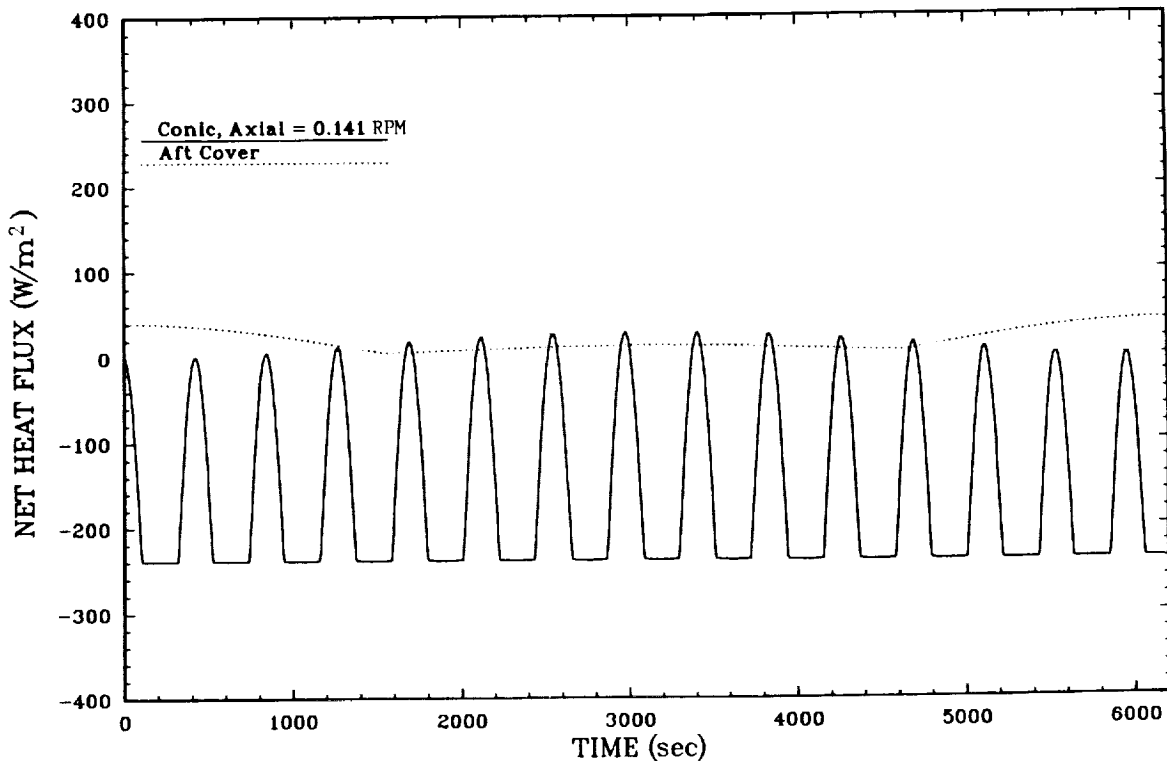

Figure 5-2. Net Heat Flux on Aft Cover and Aeroshell (180° Conic Station) for DRM-3, Vernal/Autumnal Equinox, Gravity Gradient Vehicle Orientation.

Having identified a location for a space radiator on the SAIC RRS, a TCS concept for the ECLSS heat exchanger was developed. The resulting subsystem is presented in Figure 5-3. Coolant is pumped through the ECLSS heat exchanger and then distributed into one of two sets of cooling tubes, each spanning 180° sections of opposing aeroshell circumference. The cooling tubes are integrated directly into aeroshell's aluminum substructure. During transit, heat is transferred from the coolant to the aeroshell backface and then conducted to the aeroshell surface where it is radiated to the environment. The cooled fluid streams are then merged and pass through a reservoir before returning to the heat exchanger.

A schematic of the complete ECLSS heat exchanger TCS is presented in Figure 5-4. Valves are incorporated to permit the network to interface with a ground support cooling system during the RRS prelaunch period. Additional valves are included to permit the coolant loop to bypass the ECLSS heat exchanger and/or space radiator and thereby provide some degree of coolant temperature control. An auxiliary pump serves as a backup in the event of primary pump dysfunction or failure. A thermal control unit interfaces with the various valves providing fluid network flow control as dictated by the environmental control unit processor.



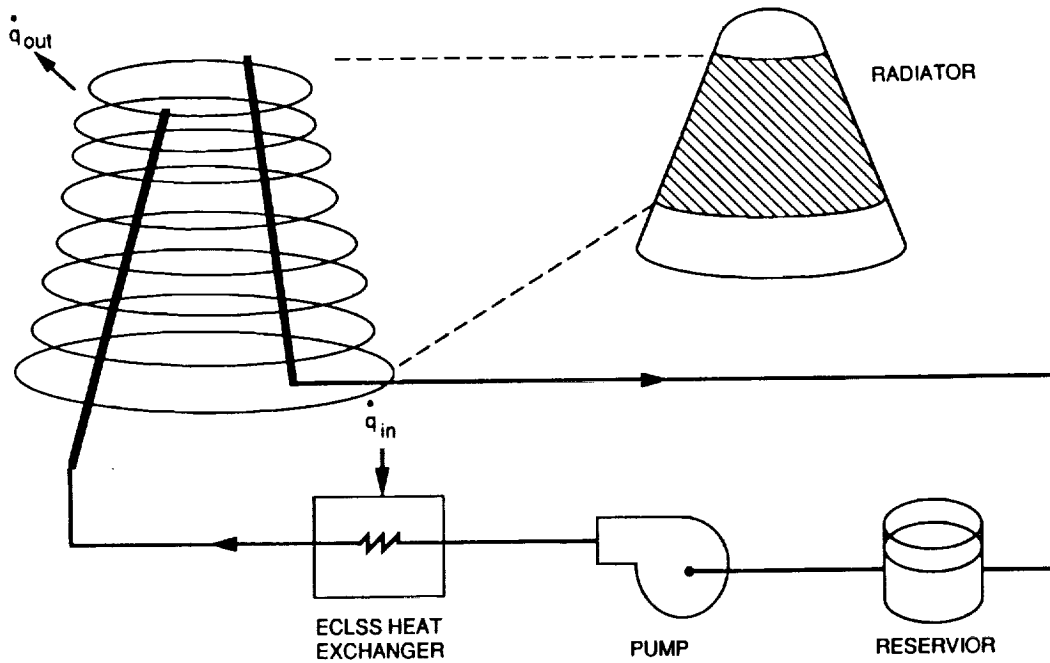

Figure 5-3. Payload Module ECLSS Heat Exchanger TCS Coolant Loop and Space Radiator Concept.

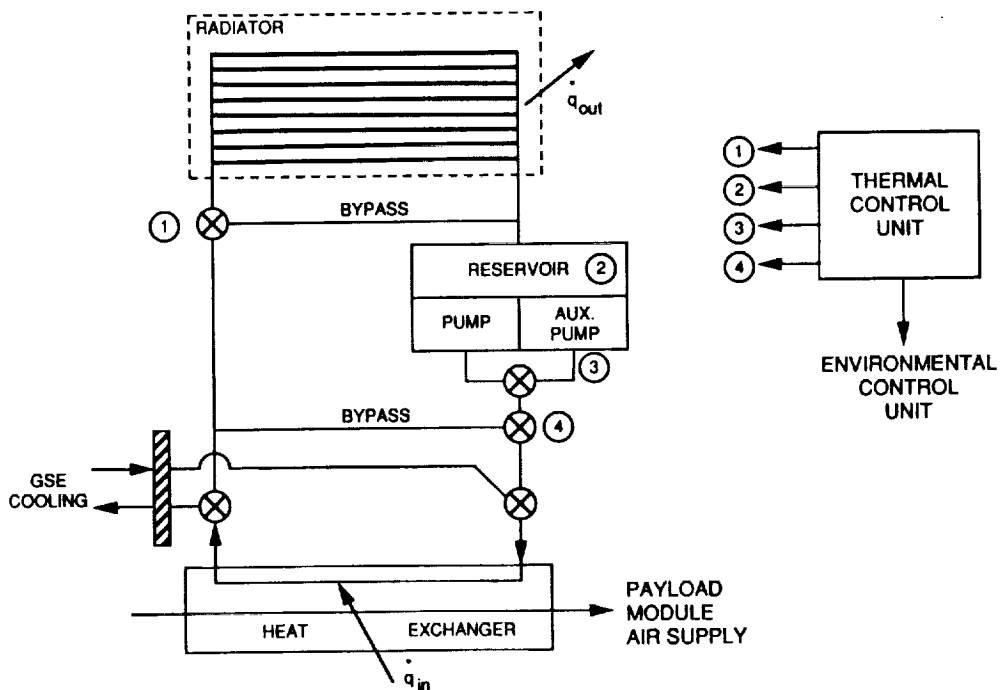

Figure 5-4. Payload Module ECLSS Heat Exchanger Thermal Control Subsystem.

Having arrived at a general TCS concept, the design issue of identifying the appropriate coolant was addressed. For this concept, it was decided that a low system operating pressure of somewhere between 10 to 20 psia would provide a good balance of safety, cost, complexity, thermal efficiency, power requirements, and weight. At these pressures and anticipated ECLSS heat exchanger temperatures ranging between 270 to 300 K, a single-phase system using a liquid coolant such as ethylene glycol appeared appropriate. One inherent disadvantage, however, with using this coolant is that its viscosity displays a strong dependence on temperature. As a result, the viscosity becomes restrictively high as the temperature approaches its freezing point of 258 K. Therefore, in addition to a maximum allowable coolant temperature of 291 K imposed by the PM payload, a minimum allowable coolant temperature of 273 K was artificially imposed to prevent the viscosity of the glycol from becoming unacceptably large.

## **5.2 Modeling Tool**

To assess the performance of the proposed TCS concept, a modeling tool capable of handling in depth thermal response of multi-material structures, coupled with the thermal-fluid response of a coolant network, was required. Such a capability is achieved in the SAIC-developed Hypersonic-Vehicle Structural, Thermal, and Acoustic Management (HYSTAM) computer code (Ref. 3). HYSTAM was originally developed to assess the performance of candidate cooling concepts for hypersonic vehicles. The code consists of three coupled modules that predict aeroheating and acoustics loads, structure thermal response, and cooling network thermal-fluid response. For the application at hand, the aeroheating and acoustics module was replaced by a module that predicted the solar insolation, Earth-reflected solar insolation, and Earth IR flux on an arbitrarily oriented surface in Earth orbit. Included within the routine were algorithms that tracked the orientation of each radiator panel as a function of vehicle rotations and orientation relative to the orbital plane.

## **5.3 Model**

The philosophy adopted in this assessment was to model as thoroughly as possible the thermal-fluid response of the coolant, the transport of heat through the aeroshell thickness, and the consequent radiant heat balance of the aeroshell surface with the extraterrestrial environment. The conceptual construction began with the subdivision of the aeroshell into 12 equivalent rectangular panels, approximately 80 by 46 cm on a side as shown in Figure 5-5. Each panel represented 30° of vehicle circumference and the combined areas matched that of the actual conic's midsection minus the aft skirt and nose cap. Each panel consisted of a 2.286 cm lay-up of ESM (the aeroshell

thermal protection material) over a 0.145 cm substrate of aluminum into which coolant passages were integrated as shown in Figure 5-6. This was an approximation of the actual substrate that will be aluminum honeycomb with aluminum coolant tubes bonded to the inner surface of the outboard facing sheet. However, the mass of the solid aluminum plate modeled replicated the anticipated mass of the actual substrate. Although the number and size of the coolant tubes was arrived at iteratively as part of the assessment process, it is noted at this time that the TCS design requires eight coolant tubes, 0.899 cm in diameter, spaced 5 cm apart.

The aeroshell ESM surface was coated with a low absorptivity white paint to enhance the dissipative efficiency of the system. A solar absorptance of 0.2 and a hemispherical emissivity of 0.9 were used in the assessment.

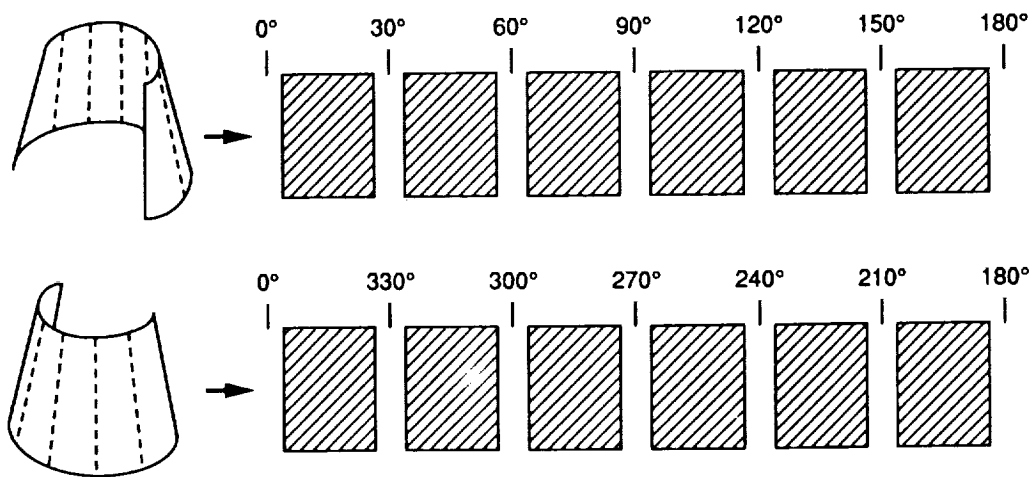

Figure 5-5. Subdivision of Aeroshell Radiator Into 12 Equivalent Panels.

Following the HYSTAM modeling approach, a fluid network model of the cooling loop and its various components was constructed. A schematic of the network and a list of the component descriptions are presented in Figure 5-7 and Table 5-1, respectively. The network model consisted of a 1 liter reservoir, a pump, the ECLSS heat exchanger, an inlet manifold which branched the flow, two sets of six panels representing 180° of vehicle circumference, a collection manifold which merged the flow, and 3 meters of miscellaneous tubing. Loss coefficients were applied to the heat exchanger and both manifolds. The pump characteristic curve used in the analysis, which was postulated, is presented in Figure 5-8.

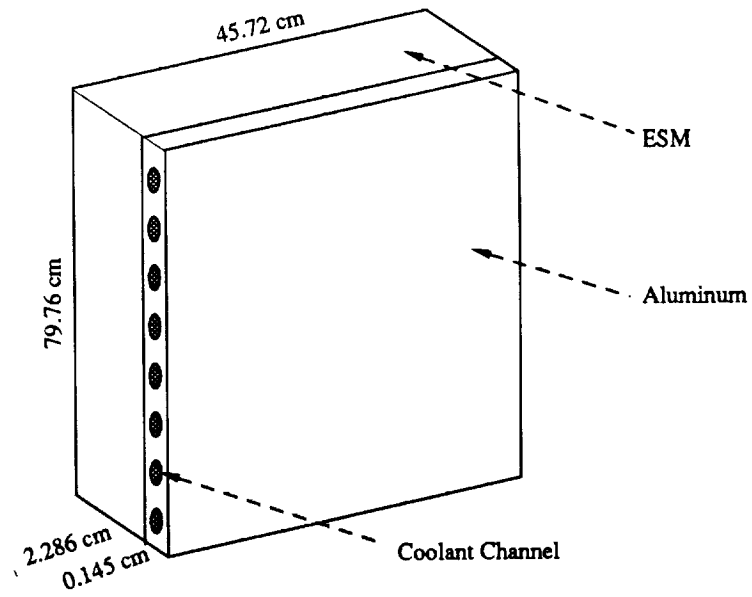

Figure 5-6. Detail of Aeroshell Radiator Panel Model.

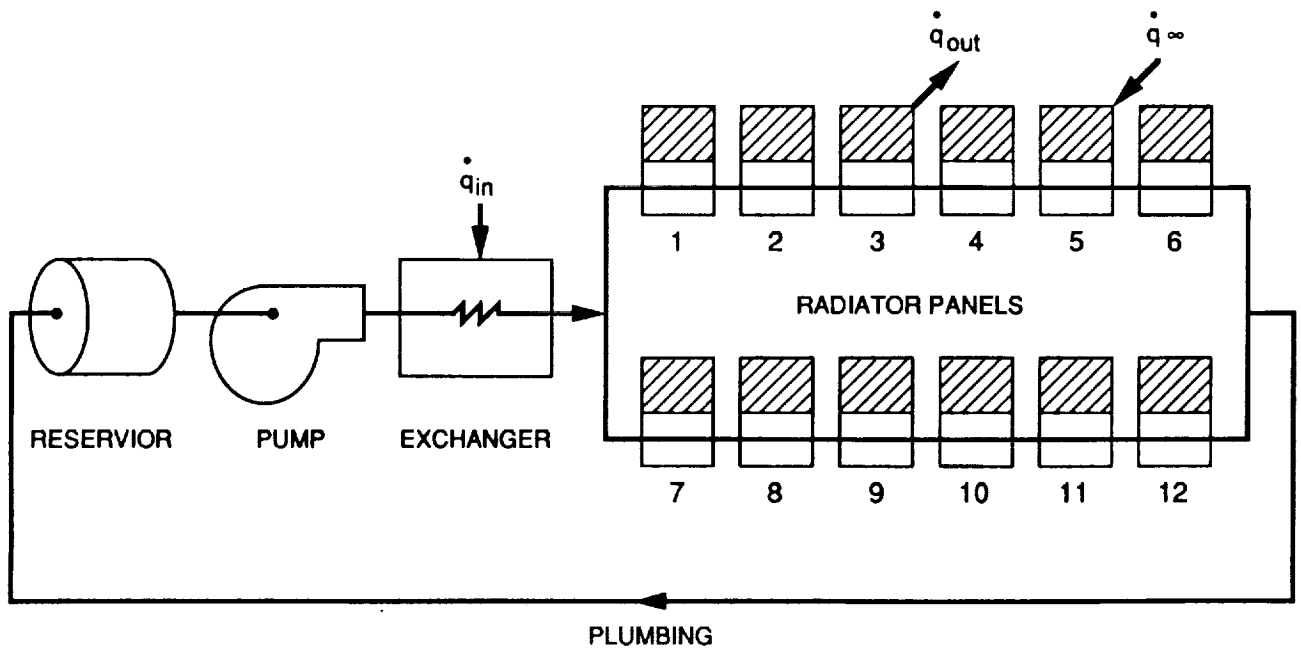

Figure 5-7. ECLSS Heat Exchanger TCS Coolant Loop Fluid Network Model.

## 5.5 Assumptions

In developing the TCS concept model, several assumptions and simplifications were necessary to adhere to the multi-one-dimensional modeling limitation in HYSTAM. The surface area of each aeroshell radiator panel was modeled exactly; however, the additional surface area provided by the aft skirt and nose sections was neglected. The spherical geometry of the nosecap and the complex radiant heating and exchange experienced by the skirt's backface present situations HYSTAM could not model. Intuitively, one may surmise that the additional area will enhance the overall efficiency of the radiator.

Table 5-1. ECLSS Heat Exchanger TCS Coolant Loop Fluid Network Components.

Reservoir	Volume Pressure Material	= 0.001 m <sup>3</sup> = 14.7 psia = Aluminum
Pump	See Figure 5-8	
Heat Exchanger	120 W continuous	
Radiator Panel (see Figure 5-6)	Surface: Backface:	$\epsilon_H = 0.9$ $\alpha_S = 0.2$ Adiabatic
Coolant Tube (see Figure 5-6)	Number Diameter Material	= 8 / panel = 0.889 cm = Aluminum
Plumbing (assorted tubing)	Total Length Diameter Material	= 304.8 cm = 1.27 cm = Aluminum
Coolant	Ethylene Glycol	

In the model, the backface of the aeroshell substructure was treated as a perfectly adiabatic boundary. A low density insulation will cover the substructure surface to minimize heat transfer with vehicle's internals, however, some radiant exchange will still take place. As noted above, HYSTAM is not configured to model the complex radiant exchange between the insulation and the satellite's internals. However, the temperature differences between the various internal surfaces and the substructure insulation will be small and, therefore, the consequent radiant transfer of heat should be negligible.

With regard to the ECLSS heat exchanger, no attempt was made to model the time variant nature of the heat load or the transport of heat from the incoming PM air to the coolant. For this analysis, the heat exchanger control volume served as a continuous 120 W source term in the fluid's thermal energy balance.

Lastly, since the HYSTAM approach is multi-one-dimensional, no structural thermal communication was permitted between panels. However, the heating loads about the aeroshell's circumference will be essentially uniform because of the vehicle's constant axial rotation. This will result in a fairly uniform temperature distribution, consequently negating circumferential conduction.

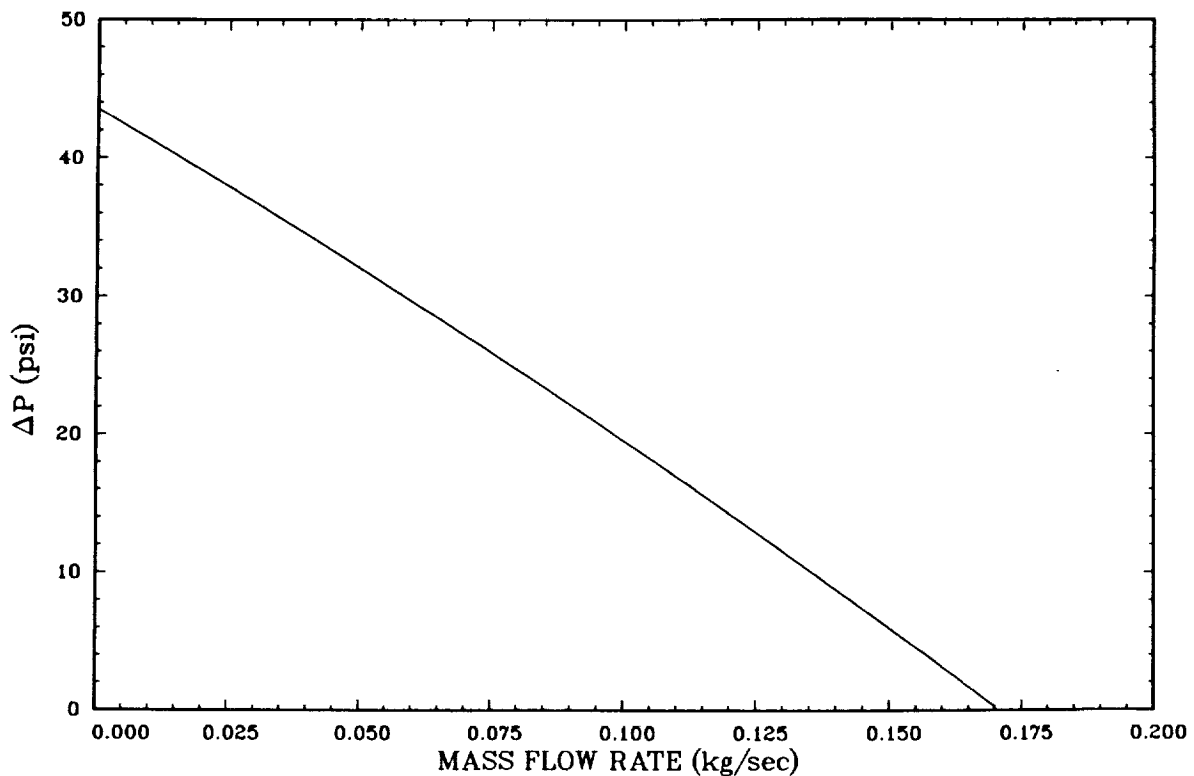

Figure 5-8. ECLSS Heat Exchanger TCS Pump Characteristic Curve.

## 5.6 Results

Prior to exercising HYSTAM, a preliminary set of computations was conducted to ascertain which of the 30 possible DRM/vehicle orientation/season combinations (five DRMs, three seasons, two vehicle orientations) subjected the aeroshell's surface to the most stressing thermal environments. The goal was to economize the required number of HYSTAM runs by concentrating on the scenarios that produced the highest and lowest aeroshell heating rates and,

therefore, the hottest and coldest aeroshell surface temperatures. The orbital geometry and vehicle orientation and rotation modes considered in the analysis are portrayed in Figure 5-9. The same orbital heat loads model used for the aft cover and aeroshell heat balance computations described previously was used. For this investigation, however, surface reradiation was not computed.

For the analysis, total absorbed flux computations were performed for DRMs 1 through 5, considering both normal rotation (7 rpm, see Figure 5-9) and gravity gradient vehicle orientations with a constant axial rotation rate of 0.14 rpm. Orbit inclination angle relative to the ecliptic was adjusted to account for Vernal/Autumnal Equinox, Summer Solstice, and Winter Solstice seasonal variations. The analysis location corresponded to the aeroshell's 15° circumferential station which translated to the center of panel 1 in the coolant loop fluid network model.

Based on the results of this preliminary investigation for the 30 possible combinations, the average absorbed flux at the aeroshell's surface during one orbital period ranged between 76 and 103 W/m<sup>2</sup>. These extremes corresponded to the DRM-5, Summer Solstice and the DRM-3, Vernal/Autumnal Equinox orbits with the vehicle in a 7 rpm normal rotation mode. Table 5-2 depicts the parameters that define these two orbits. The total absorbed flux witnessed by aeroshell panel 1, as a function of time for these two orbits, is presented in Figure 5-10.

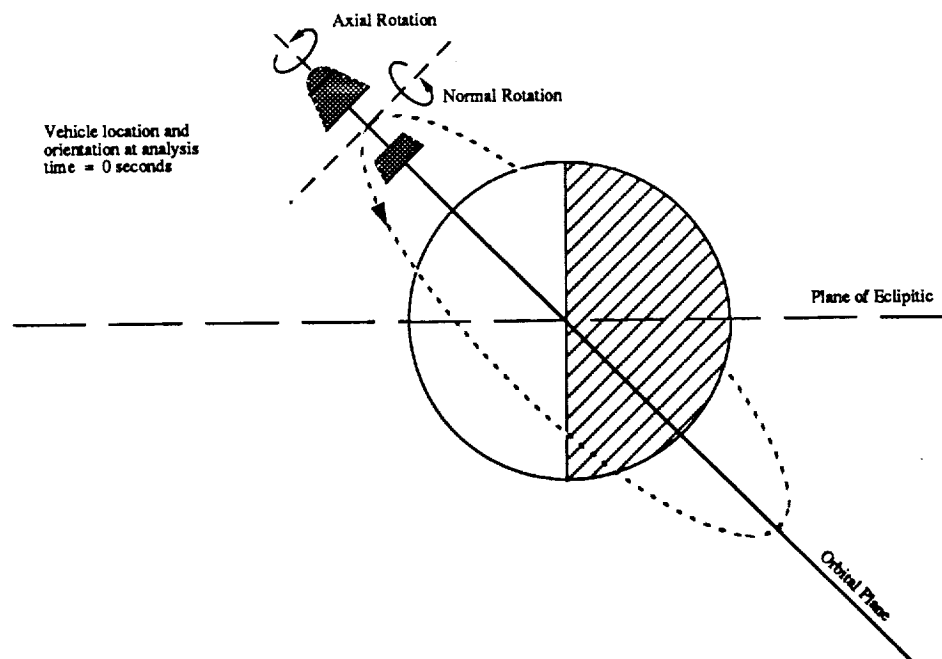

Figure 5-9. Orbital Geometry and Vehicle Orientation and Rotation Modes Considered in Total Absorbed Flux Computations.

Having defined a TCS network model and identified the most stressing orbits, the thermal/hydraulic response of the fluid network and space radiator were assessed using HYSTAM. Figure 5-11 shows the predicted hydraulic response of the subsystem at steady-state conditions for both orbits. The computed pump power, assuming an efficiency of 65%, is a continuous 7.4 W. The pump produces approximately 5 psia of head, a coolant mass flow rate of 0.153 kg/sec, and a coolant velocity of 0.137 m/sec within the radiator coolant tubes.

Table 5-2. DRM-3, Vernal/Autumnal Equinox and DRM-5, Summer Solstice Orbit Definitions.

<b>Designation</b>	<b>DRM-3 Vernal/Autumnal Equinox</b>	<b>DRM-5 Summer Solstice</b>
Orbit Inclination (relative to ecliptic)	98°	5°
Orbital Period	6176 sec	5492 sec
Occultation Period	0 sec	2177 sec
Altitude	897 km	350 km
Normal Rotation	7 rpm	7 rpm
Axial Rotation	0.14 rpm	0.14 rpm

The predicted thermal response of the coolant for both orbits is presented in Figure 5-12. The temperatures correspond to that of the fluid as it enters the ECLSS heat exchanger. The initial system temperature for the DRM-3 orbit was set at 300 K and was designated the hot orbit/hot start condition. The initial system temperature for the DRM-5 orbit was set at 280 K and was designated the cold orbit/cold start condition. The intent was simply to derive some insight into how initial temperature influenced the time required for the subsystem to reach a steady-state operating condition.

The hot orbit/hot start condition requires the coolant loop to bypass the heat exchanger for approximately 3600 seconds. The bypass permits the residual heat within the subsystem to dissipate allowing the temperature of the coolant to drop below the 291 K maximum allowable for ECLSS heat exchanger. For the analysis, the bypass was simulated by switching the 120 W source term in the ECLSS heat exchanger control volume on at 3600 seconds into the calculation. This is evidenced in Figure 5-12 by the burp in the coolant temperature response curve. For the DRM-3 orbit, the coolant temperature stabilizes at 284 K.



DRM-3, NR = 7.0 RPM, Axial = 0.14 RPM  
 $a_s = 0.2, \epsilon_{IH} = 0.9, \text{albedo} = 0.35, T_e = 289 \text{ K}, T_{ref} = 270 \text{ K}$

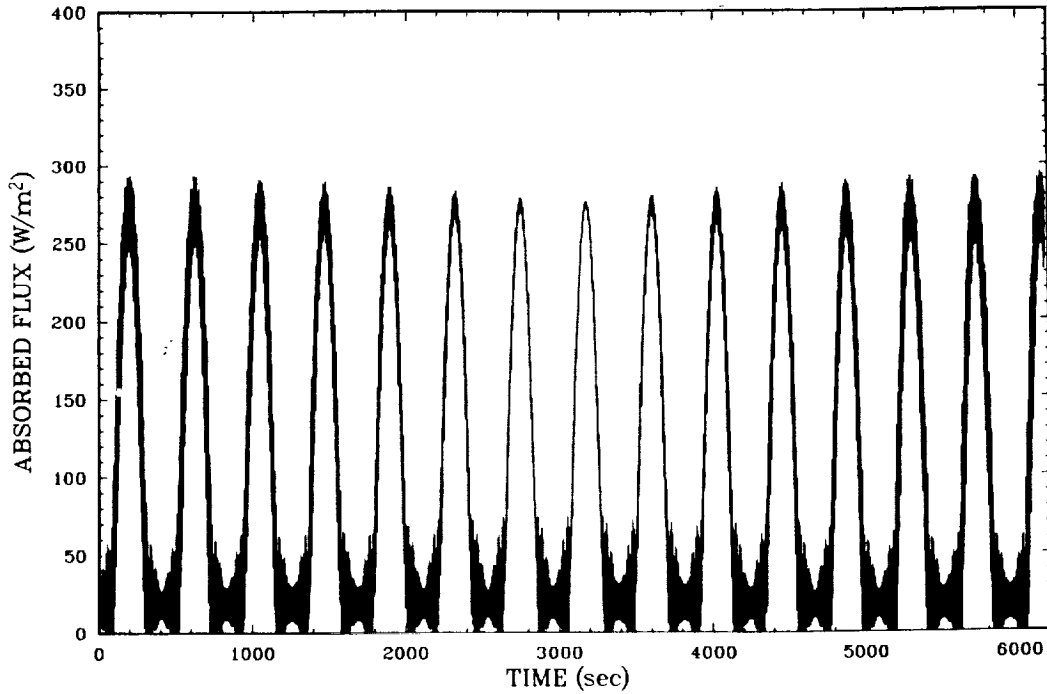

DRM-5, NR = 7.0 RPM, Axial = 0.14 RPM  
 $a_s = 0.2, \epsilon_{IH} = 0.9, \text{albedo} = 0.35, T_e = 289 \text{ K}, T_{ref} = 270 \text{ K}$

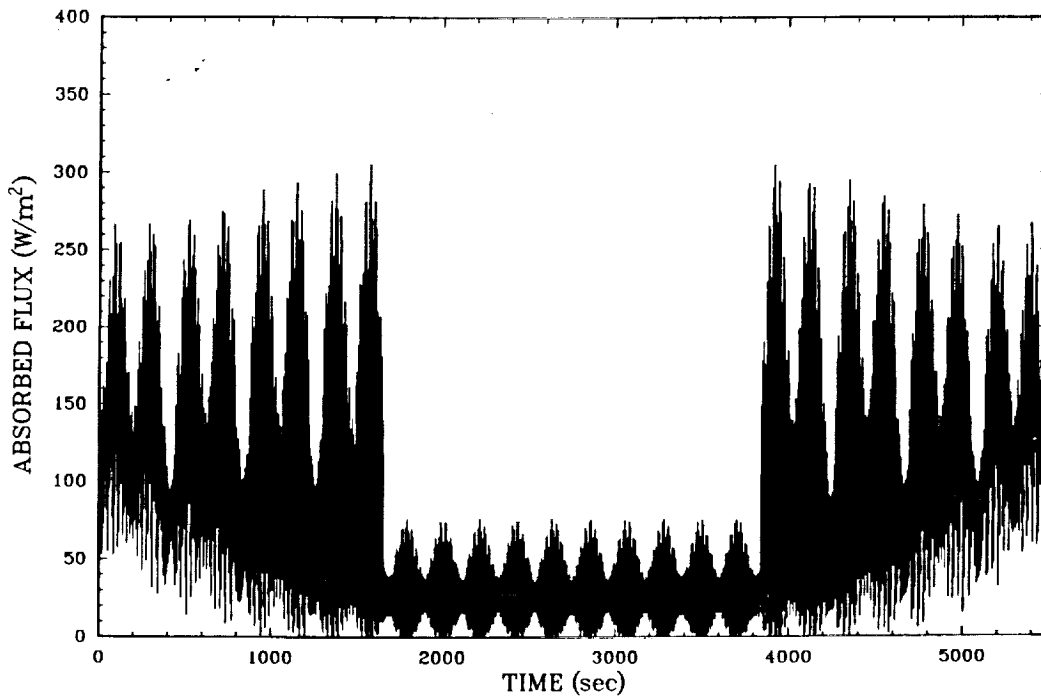

Figure 5-10. Total Absorbed Flux (Solar + Albedo + Earth IR) at Radiator Panel 1 Surface During One Orbital Period for DRM-3, Vernal/Autumnal Equinox and DRM-5, Summer Solstice With Vehicle Normal and Axial Rotation Rates of 7.0 and 0.14 rpm, Respectively.

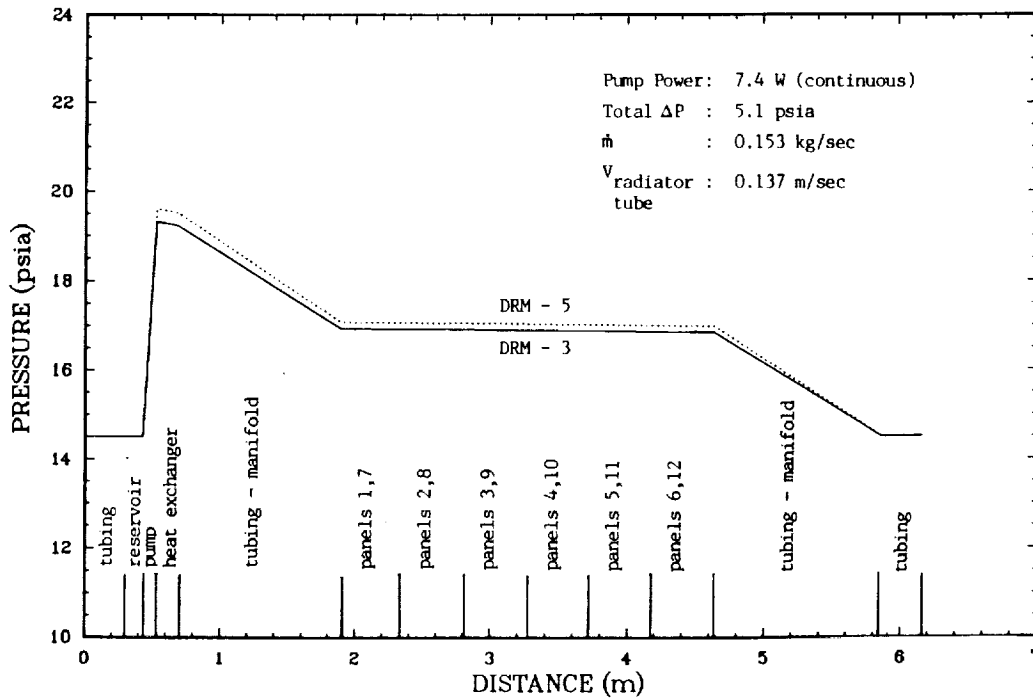

Figure 5-11. Fluid Network Hydraulic Response

Fluid Temperature at Heat Exchanger Inlet

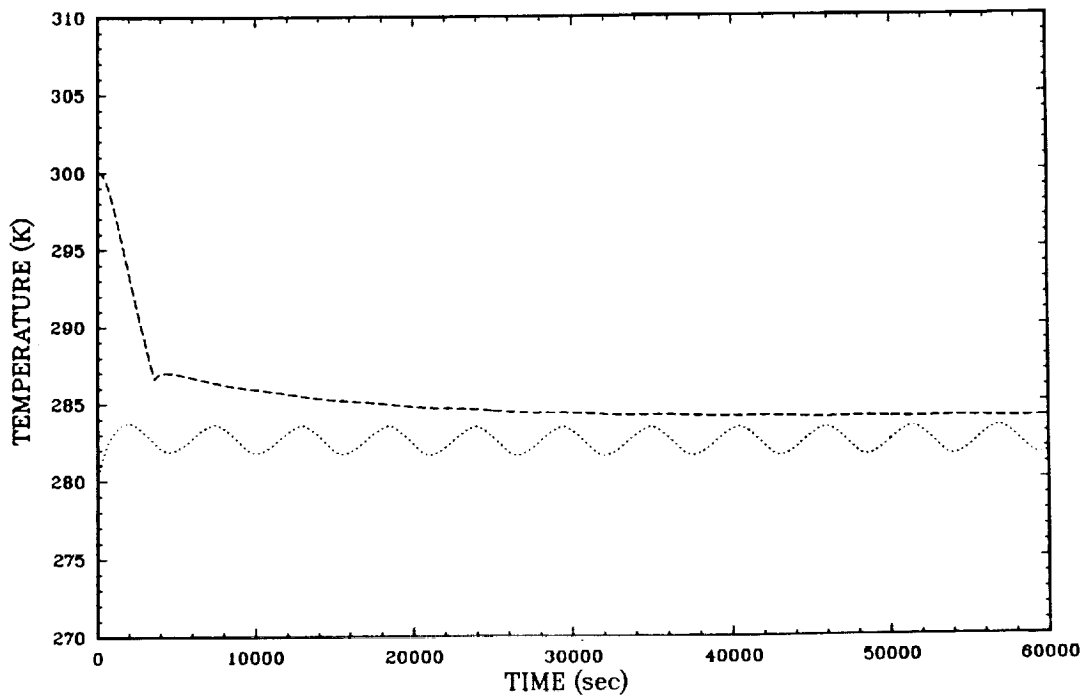

Figure 5-12. Coolant Thermal Response

Considering the cold orbit/cold start condition, the prediction indicates that the coolant temperature quickly equilibrates to a pseudo-steady-state condition between 282 and 284 K. The periodic oscillation in the coolant temperature response is the result of the 2177 second occultation period that occurs during the DRM-5 orbit. Note that the coolant temperatures achieved for both orbits fall between the maximum and minimum allowable coolant temperatures of 291 and 273 K identified previously.

The required number and diameter of coolant tubes in the space radiator were arrived at iteratively by performing successive sets of HYSTAM computations. The above coolant temperatures were achieved using eight, 0.889 cm diameter tubes per panel spaced 5 cm apart.

Figure 5-13 permits a comparison of the thermal response of the coolant relative to that of the aeroshell surface. The temperature response at the surface of radiator panels 1 and 4 (15° and 105°) are shown in relation to the coolant temperature as a function of time for both DRM-3 and DRM-5. The aeroshell surface temperature ranges between 260 to 280 K. In addition, the results indicate that the maximum temperature difference between adjacent panels does not exceed 3 K. Therefore, circumferential conduction about the aeroshell is negligible as assumed originally.

Having arrived at a viable concept, a weight estimate of the proposed TCS was made assuming a construction entirely of aluminum. The complete breakdown for the subsystem is given in Table 5-3. The total weight calculated, excluding the ECLSS heat exchanger and the aeroshell and its substructure, is 38.4 lbs (17.4 kg).

Table 5-3. PM ECLSS TCS Weight Budget.

<b>Component</b>	<b>Mass lbs (kg)</b>
Coolant	10.8 (4.9)
Tubing	15.6 (7.1)
Pumps	5.5 (2.5)
Reservoir	3.1 (1.4)
Valves and fittings	2.2 (1.0)
Structure	1.1 (0.5)
<b>TOTAL</b>	<b>38.4 (17.4)</b>

DRM-3, Vernal/Autumnal Equinox ( $T_i = 300$  K)  
Normal Rotation = 7.0 RPM, Axial Rotation = 0.14 RPM

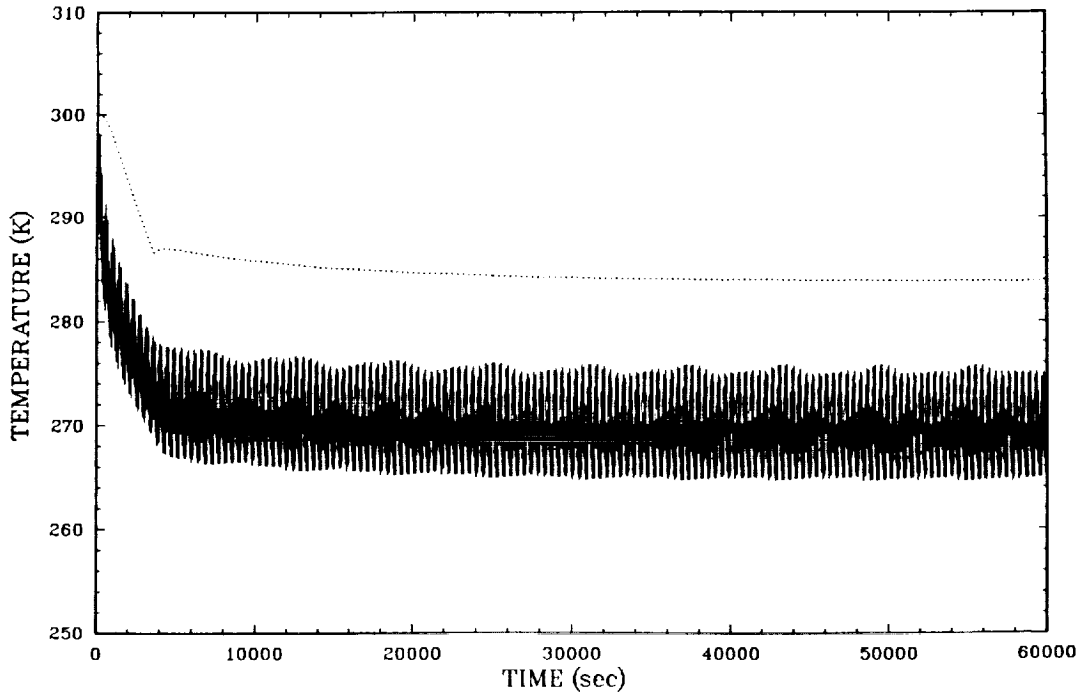

DRM-5, Summer Solstice ( $T_i = 280$  K)  
Normal Rotation = 7.0 RPM, Axial Rotation = 0.14 RPM

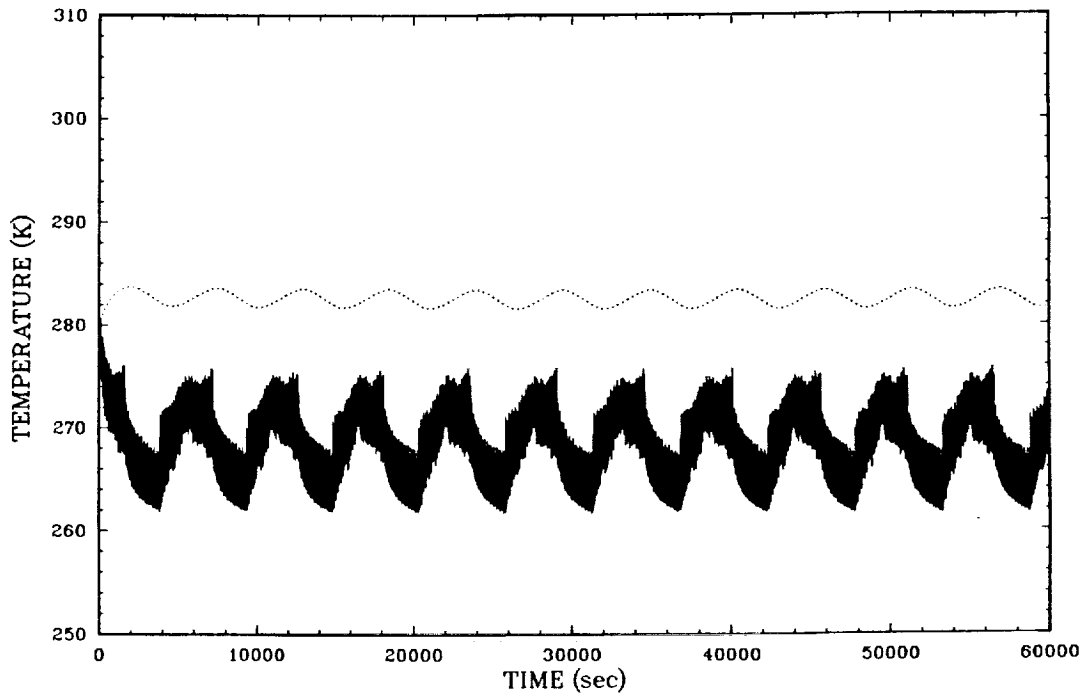

Figure 5-13. Aeroshell Surface and Coolant Thermal Response, DRM-3 and DRM-5.

## **5.7 Conclusions**

Based on results reported in the Ames Reusable Reentry Satellite Design Study and the current trade study, it was concluded that an active TCS, consisting of a fluid network coupled with a space radiator, was a viable thermal control concept for the SAIC RRS Payload Module's ECLSS heat exchanger. A preliminary thermal response calculation indicated that the RRS aeroshell would serve as an acceptable location for the TCS space radiator. Based on the subsystem's projected operating pressure and temperature, the liquid coolant ethylene glycol was chosen as the TCS working fluid.

A thermal-fluid response assessment of the proposed TCS was performed using the HYSTAM computer code. The analysis considered the two RRS orbit/vehicle orientation/seasonal combinations that subjected the aeroshell to the most stressing thermal environments. The aeroshell surface was coated with a low absorptivity white paint to enhance its dissipative efficiency. The coating was assumed to have a solar absorptance of 0.2 and a hemispherical emissivity of 0.9. The results indicated that eight, 0.889 cm diameter coolant tubes integrated into the aeroshell's substructure effectively dissipated the heat exchanger's 120 W heat load while maintaining the coolant within the mandated temperature range of 273 to 291 K.

The pump power requirement for the TCS was estimated to be a continuous 7.4 W. The projected weight of the complete subsystem is 38.4 lbs (17.4 kg).

## **6.0 EXTENDED MODULE PROPELLANT THERMAL RESPONSE**

### **6.1 Introduction**

The RRS extended module contains six spherical tanks fabricated from titanium in which hydrazine propellant is stored. Current system requirements dictate that the temperature of the propellant must be maintained between 275 and 330 K to ensure its safe containment. The tanks are almost completely enclosed by surrounding surfaces and thereby shielded from direct extraterrestrial exposure, however, because of the wide array of orbit types and vehicle orientations the RRS might encounter, thermal exchange with these externally exposed structures will still take place. Therefore, it is probable that under certain conditions the temperature of the tanks and their accompanying propellant will violate the above requirement if corrective measures, such as insulations, spectrally selective coatings, or heaters, are not imposed. This section describes the

thermal assessment of the extended module that was performed to ascertain which corrective measures, if any, were necessary.

## 6.2 Modeling Tool

The extended module presents a relatively complex three dimension geometry that experiences radiant exchange with its extraterrestrial environment as well as radiant and conductive exchange between its component parts. The SAIC-developed Thermal Analyzer for Systems Components (TASC) computer code is well suited for this application (Ref. 4). TASC is a lumped-capacitance, electrical resistor-capacitor network analog-based code for analyzing time-dependent thermal response of arbitrarily configured, multi-material, one, two, and three dimensional systems. A routine for computing direct solar insolation, Earth-reflected solar insolation, and Earth IR radiation on an arbitrarily oriented surface was integrated into the code which computed the magnitudes of these radiant components exactly as a function the extended module's time variant orbital position and orientation. This routine was an adaptation of the model used in the ECLSS TCS heat balance and HYSTAM computations described in Section 5.0.

## 6.3 Model

A pictorial representation of the extended module model developed for this assessment is presented in Figure 6-1. The model consisted of a truncated cone composed of a solar array over a substrate of aluminum honeycomb, two circular aluminum honeycomb disks serving as forward and aft covers, and six tanks, half full of hydrazine (nominal condition), suspended within the resulting enclosure. The entire model experienced rotations as prescribed by the particular orbital mission under consideration. The solar array and the external surfaces of the covers were exposed to direct solar insolation, Earth-reflected solar insolation, and Earth IR radiation and experienced radiant exchange with the Earth and deep space.

Before developing a TASC electrical network analog for the extended module model, a set of preliminary calculations was undertaken to assess the thermal response of the module's solar array. The motivation was to obtain an estimate of temperature gradients about the module's circumference and hence guide the model nodalization process.

As described above, solar panels cover the entire exterior surface of the module's truncated cone perimeter. A simple TASC model of the array was developed by dividing the truncated cone into six equivalent circumferential sections. Each section consisted of a lay-up of quartz over a

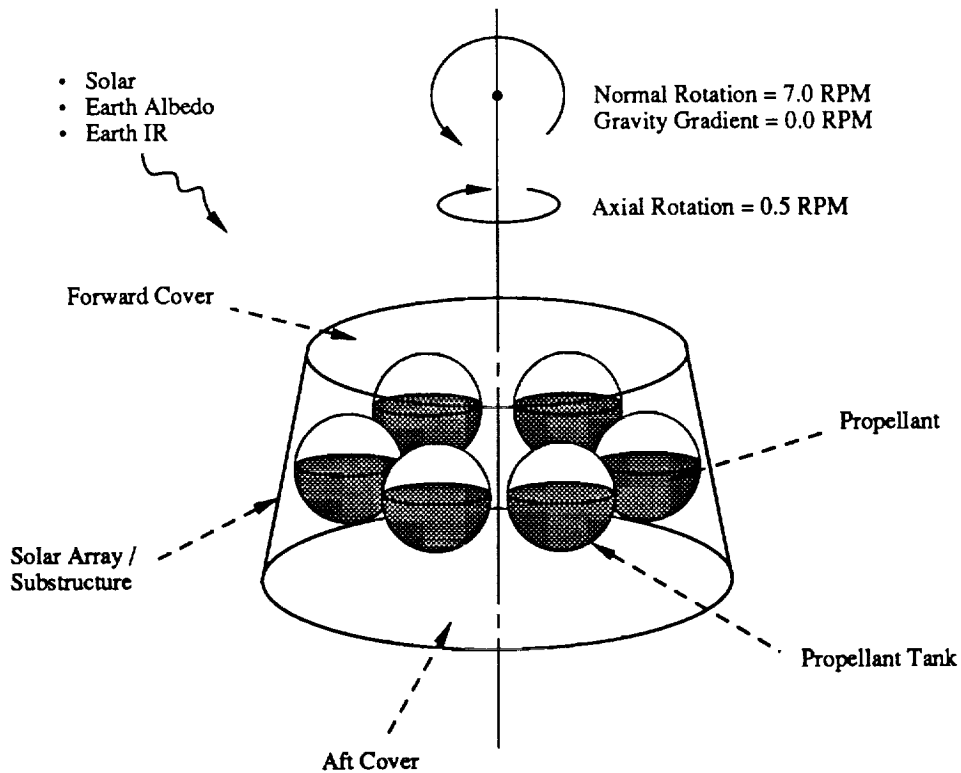

Figure 6-1. RRS Extended Module Model.

substrate of aluminum honeycomb. Each panel was permitted to communicate with its neighbors via conduction, however, no radiant exchange across the cone's interior was considered. The thermal mass and response of the remaining extended module's structure was ignored.

The TASC code was exercised for the DRM-3 orbit at Vernal/Autumnal Equinox with the vehicle in the gravity gradient orientation (no vehicle rotation, vehicle's axis is perpendicular to the Earth's surface, and vehicle nose facing outward). From analyses discussed in Section 5.0, this scenario was determined to impose the highest heat loads on vehicle conic surfaces. Figure 6-2 presents a pictorial representation of the orbital geometry and vehicle orientation considered.

The results are presented in Figure 6-3 which plots the temperature response at the centroid of each panel versus time. The temperatures experienced by the sun facing panels ( $\sim 120^\circ$  -  $180^\circ$  -  $\sim 240^\circ$ ) cause a substantial degradation in the array's overall efficiency and a consequent loss in power production that is unacceptable.

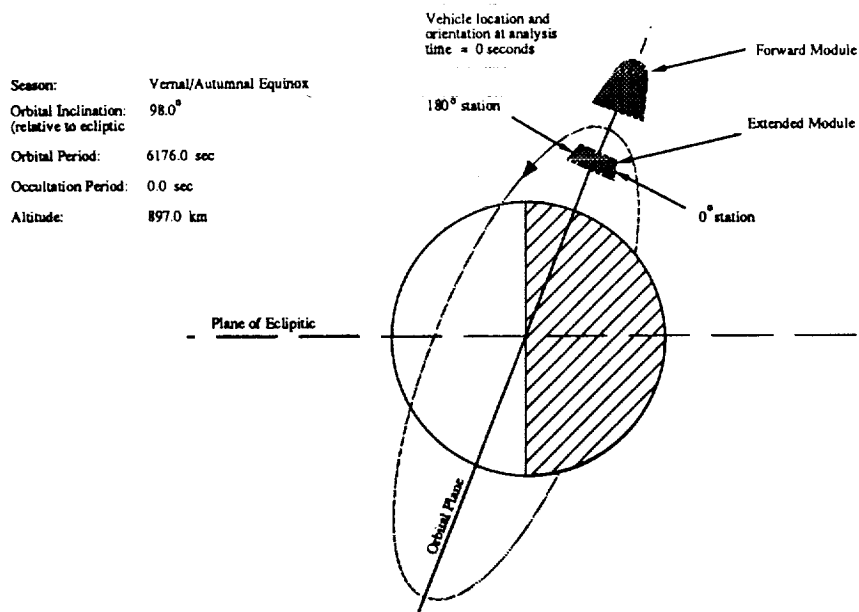

Figure 6-2. DRM-3 Orbital Geometry and RRS Vehicle Orientation Considered in Extended Module Solar Array Thermal Response Analysis.

An obvious solution for eliminating the large nonuniformity in temperature about the module's circumference is to impose an axial rotation on the entire vehicle. However, the loads induced by such a rotation must not produce an acceleration greater than  $10^{-5}$  g as set forth in the RRS System Design Study Statement of Work, Section 4.2.5.2 (Ref. 2). A simple calculation sets the maximum allowable axial rotation rate at 0.14 rpm. This rotation produces an acceleration of  $10^{-5}$  g at the PMs 44.5 cm outer radius. This results in an acceptable  $0.8 \times 10^{-5}$  g at the maximum rodent cage radius of 35.6 cm.

Repeating the previously described TASC analysis with a vehicle axial rotation rate of 0.14 rpm results in the circumferential temperature distribution presented in Figure 6-4. The rotation is sufficient to effectively smooth the nonuniformity and results in an array temperature of  $300 \text{ K} \pm 10 \text{ K}$ .

The above results were used to develop the electrical network analog for the extended module model shown in Figure 6-5. Because of geometric and thermal symmetry, the solar array, array substructure, and forward and aft covers were modeled as single nodes. In addition, the six propellant tanks and their resident propellant were also treated as single nodes. The surface areas, masses, and conductive contact areas between each of these structures, however, were all computed based on the extended module's actual geometry. The radiation view factors between the array substructure, forward cover, aft cover, and propellant tanks were calculated assuming no intervening obstructions.



DRM-3, Vernal/Autumnal Equinox, Gravity Gradient  
No Vehicle Axial Rotation

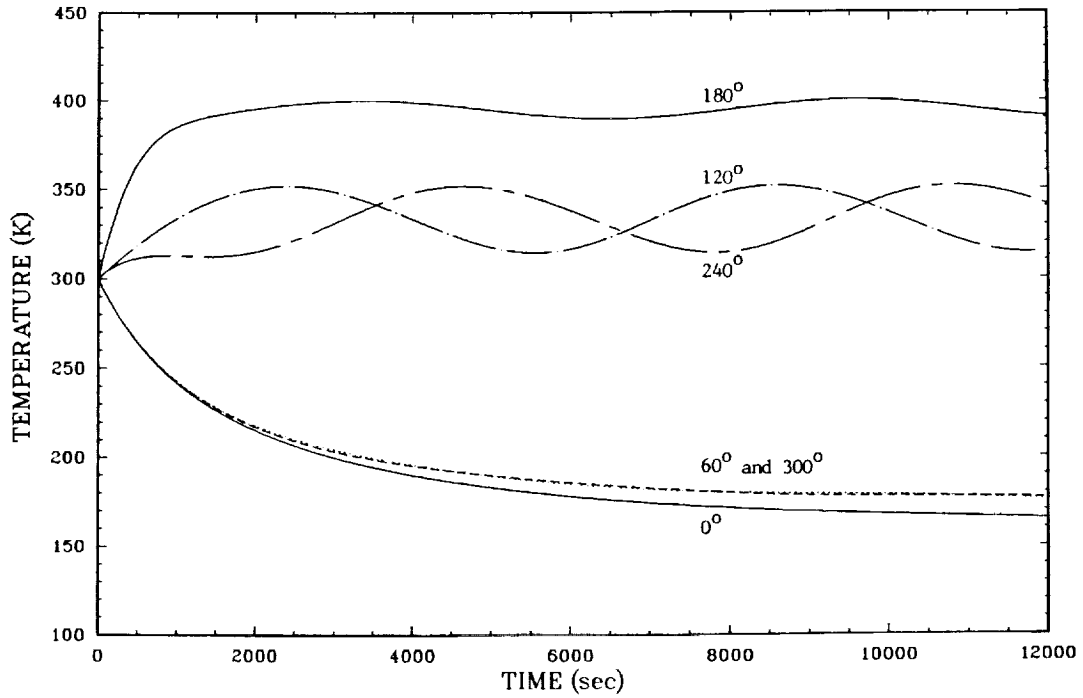

Figure 6-3. Extended Module Solar Array Thermal Response for DRM-3 Orbit.  
DRM-3, Vernal/Autumnal Equinox, Gravity Gradient  
Vehicle Axial Rotation = 0.14 RPM

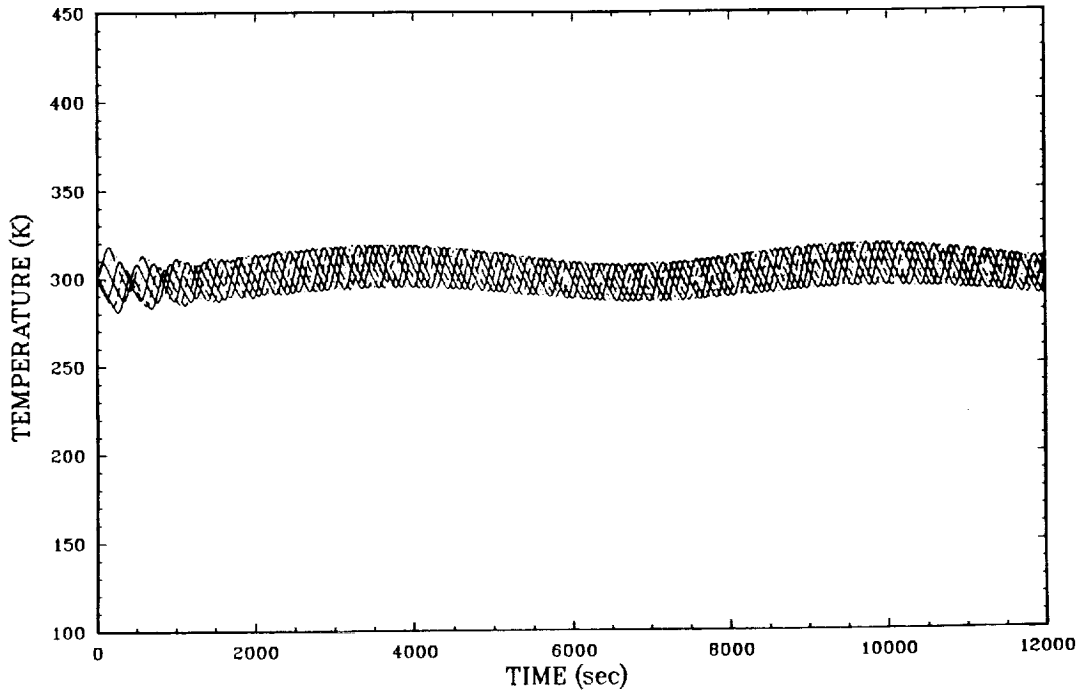
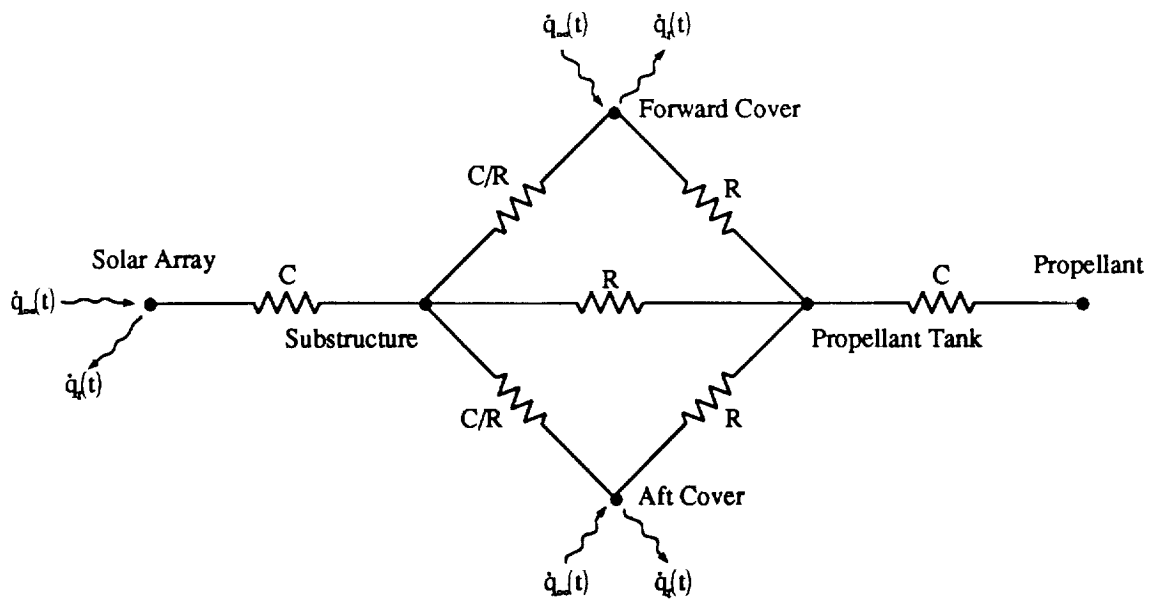

Figure 6-4. Extended Module Solar Array Thermal Response for DRM-3 Orbit With and Axial  
Rotation of 0.14 rpm



- $\dot{q}_e(t)$  : Radiation to environment (Deep Space, Earth)
- $\dot{q}_i(t)$  : Radiation from environment (Solar, Earth Albedo, Earth IR)
- C : Conduction
- R : Radiation

Figure 6-5. Extended Module Model Electrical Network Analog

Table 6-1 describes the material, mass, and radiant properties for each of the six network nodes. The external surfaces of the forward and aft covers were coated with a high absorptivity black paint. The coating was assumed to have a solar absorptance and hemispherical emissivity of 0.9. For the DRM-3 polar orbit, the mass of the node representing the propellant was set to zero. Since the heating environments induced by this orbit are relatively uniform, the temperatures of the various surfaces which constitute the module's exterior will not fluctuate broadly over each orbit. Since the temperatures of these surfaces in turn drive the thermal response of the propellant tanks, the tanks themselves will experience even smaller fluctuations and as a consequence equilibrate to a steady-state condition. As a result, the additional mass provided by the propellant only serves to lengthen the system's equilibrium time constant. By eliminating the mass of the propellant when considering the DRM-3 orbit, the system reaches its equilibrium condition more rapidly thereby reducing the required computation time interval.

Table 6-1. Extended Module Model Electrical Network Analog Nodal Descriptions

Node	Material Modeled	Nodal Mass (kg)	Radiant Surface Properties *
Solar Array	Quartz	3.15	$\alpha_s = 0.86 \epsilon_H = 0.80$
Substructure	Aluminum Honeycomb	20.10	$\alpha = 0.80 \epsilon = 0.80$
** Forward Cover	Aluminum Honeycomb	8.23	$\alpha_s = 0.90 \epsilon_H = 0.90$ $\alpha = 0.80 \epsilon = 0.80$
** Aft Cover	Aluminum Honeycomb	15.41	$\alpha_s = 0.90 \epsilon_H = 0.90$ $\alpha = 0.80 \epsilon = 0.80$
Propellant Tank	† Titanium	44.91	$\alpha = 0.80 \epsilon = 0.75$
Propellant	Hydrazine	DRM-3 0.0 DRM-5 154.20	

- \*  $\alpha_s$  and  $\epsilon_H$  correspond to vehicle external surfaces,  $\alpha$  and  $\epsilon$  correspond to vehicle internal surfaces
- \*\* External surfaces coated with black paint
- † External surfaces coated, but uninsulated

## 6.4 Assumptions

As is evident from the inspection of Figures 6-1 and 6-5, the model representing the extended module resulted from several simplifying assumptions that assisted in economizing the analysis without sacrificing the integrity of the predictions. Several of these assumptions have been discussed previously. The remainder are addressed here.

Since struts and/or flanges with relatively small cross-sectional areas will be used to secure the tanks within the module, it was assumed that radiative rather than conductive exchange would be the dominant mechanism of heat transfer between the module's shell and the tank surfaces. Also, it was assumed that the tanks are completely shielded from direct exposure to the external environment. This, in fact, is not the case since the forward cover is penetrated by the portion of the PM which protrudes from the forward module when the vehicle is in the retracted position. This requires an 88.9 cm diameter opening in the cover that exposes a portion of the tankage surface to the extraterrestrial environment. However, the placement of a cylindrical radiation shield of a diameter equivalent to that of the opening and extending into the module (to the aft cover if necessary) would suffice in completely isolating the tanks.

Additional assumptions were adopted in order to impart some degree of conservatism into the overall analysis. The tanks were assumed to be coated with a surface preparation, but were left uninsulated. The analysis neglected the 67 W of heat rejected from the various electronics, batteries, and hardware located within the module (a conservative estimate when considering minimum predicted temperatures). Also, as noted previously, the view factors between the tanks and the inner surfaces of the solar array and covers were computed assuming that there were no intervening obstructions.

## 6.5 Results

As was the case in the ECLSS heat exchanger TCS thermal response assessment described in Section 5.0, prior to executing the TASC code, a set of preliminary calculations was performed to determine which DRM/vehicle orientation/season combinations subjected the module's surfaces to the most stressing thermal environments. As before, the goal was minimize the number of code computations necessary to adequately assess the module's thermal performance. Figure 5-9 shows the orbital geometry and RRS vehicle orientation and rotation modes considered in the analysis. The orbital heat loads routine described in Section 5.2 was used to perform the computations in conjunction with the surface radiative properties given in Table 6-1.

The results from the above investigation indicated that the DRM-3, Vernal/Autumnal Equinox and DRM-5, Summer Solstice orbits in combination with a vehicle normal rotation rate of 7 rpm produced the lowest and highest heat loads on the module. The forward cover was the exception. This surface received the lowest and highest absorbed fluxes for the above orbits, but in combination with the gravity gradient vehicle orientation. Examples of the computed total absorbed fluxes at the surface of the extended module aft cover are presented in Figures 6-6 and 6-7 for the above scenarios.

Having identified the most thermally stressing orbits, the TASC code was exercised on the previously described extended module model. Figure 6-8 shows the predicted temperature responses of the solar array substructure, the forward and aft covers, and the propellant tank for DRM-3. Since the solar array was treated as a single node and the thermal heat balance was performed at only a single circumferential station on the conic, the 0.14 axial rotation produces an oscillatory temperature response for this surface. For both the normal rotation and gravity gradient vehicle orientations, the propellant tank equilibrates to approximately 280 K.

Figure 6-8 shows the predicted temperature responses of the solar array substructure, forward and aft covers, the propellant tank, and propellant for the DRM-5 orbit. For this orbit, the nodal temperature fluctuations are more pronounced because of the 2177 second occultation period. Although the temperature variations of the module's external surfaces fall well below the minimum propellant allowable of 275 K, the radiant coupling between these surfaces and the tank is sufficiently damped to prevent the tank temperature from dropping below 280 K. The bulk temperature of the propellant remains relatively steady, equilibrating to about 295 K for both the normal rotation and gravity gradient vehicle orientations.

## 6.6 Conclusions

An assessment of the on-orbit thermal response of the SAIC RRS extended module has shown that the propellant housed within its interior should remain between 280 to 300 K for all anticipated RRS missions. The analysis indicates that shielding the tanks from exposure to the external environment and coating the exterior surfaces of the forward and aft covers with a high absorptivity black paint are adequate measures for maintaining the propellant above its minimum allowable of 275 K. At present, it appears that no active thermal control measures such as heaters will be necessary.

DRM-3 , NR = 7.0 RPM,  
 $\alpha_s = 0.9, \epsilon_H = 0.9$ , albedo = 0.35,  $T_e = 289$  K,  $T_{ref} = 270$  K

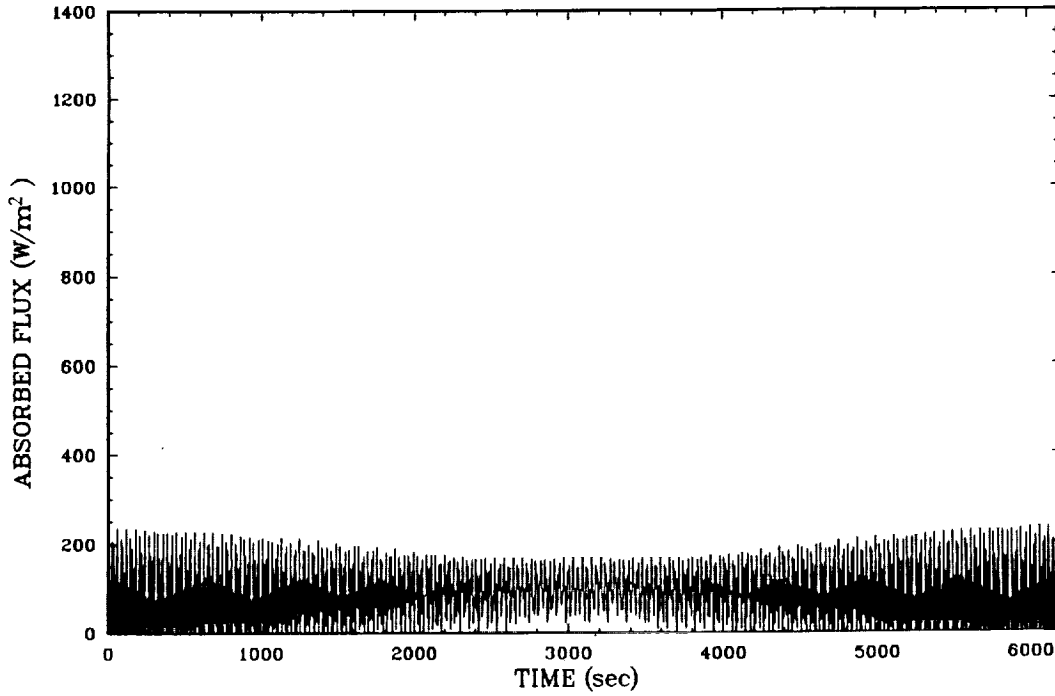

DRM-3 , Gravity Gradient,  
 $\alpha_s = 0.9, \epsilon_H = 0.9$ , albedo = 0.35,  $T_e = 289$  K,  $T_{ref} = 270$  K

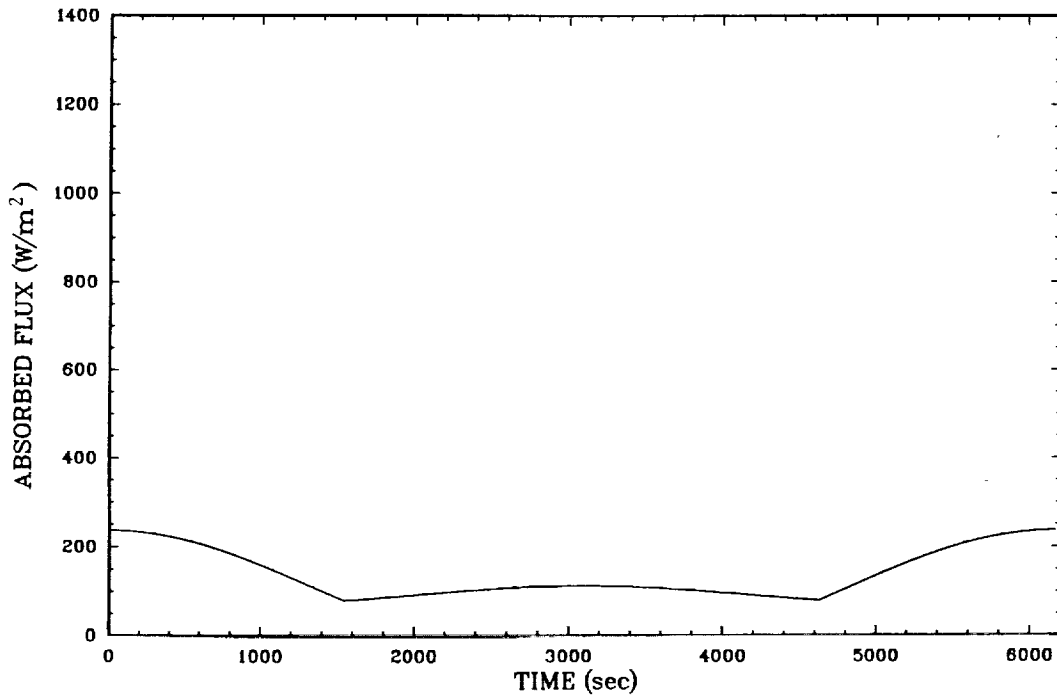

Figure 6-6. Total Absorbed Flux (Solar + Albedo + Earth IR) at Extended Module Aft Cover Surface During One Orbital Period for DRM-3, Vernal/Autumnal Equinox, Normal Rotation and Gravity Gradient Vehicle Orientations.

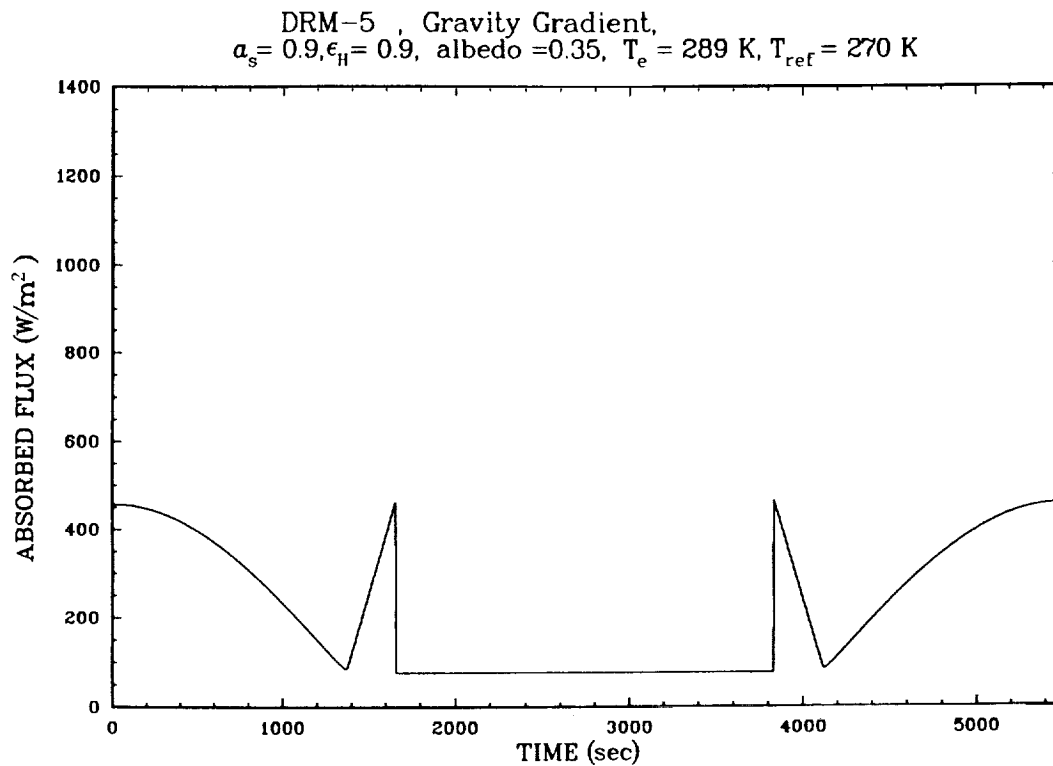
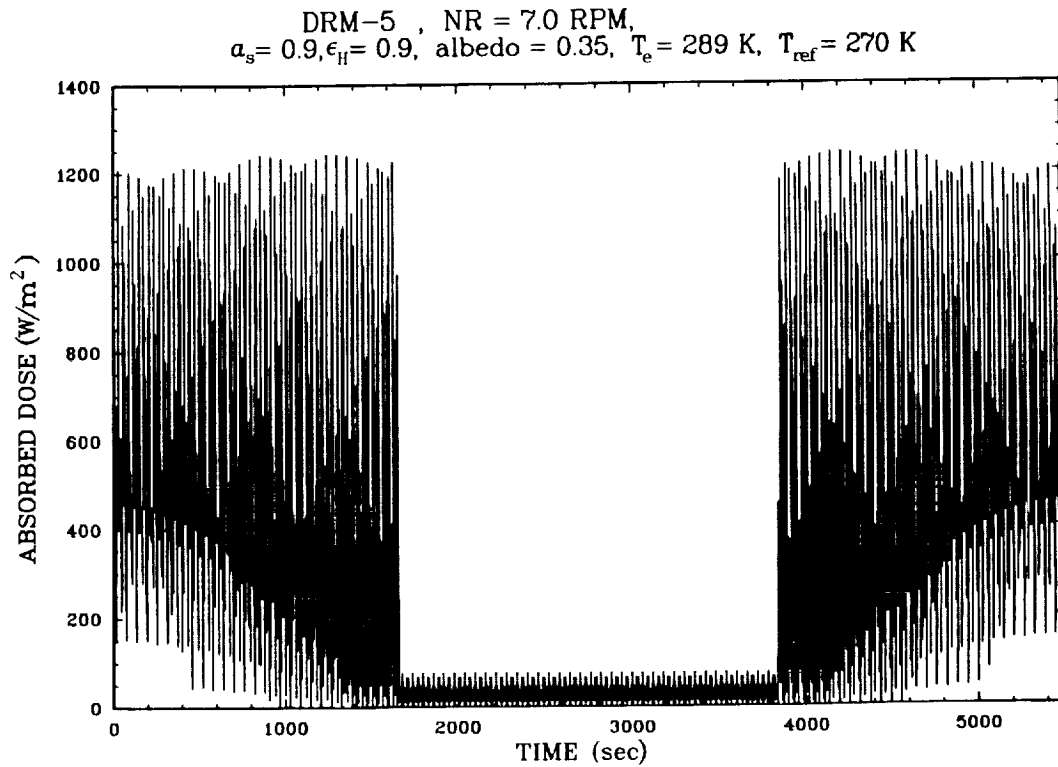
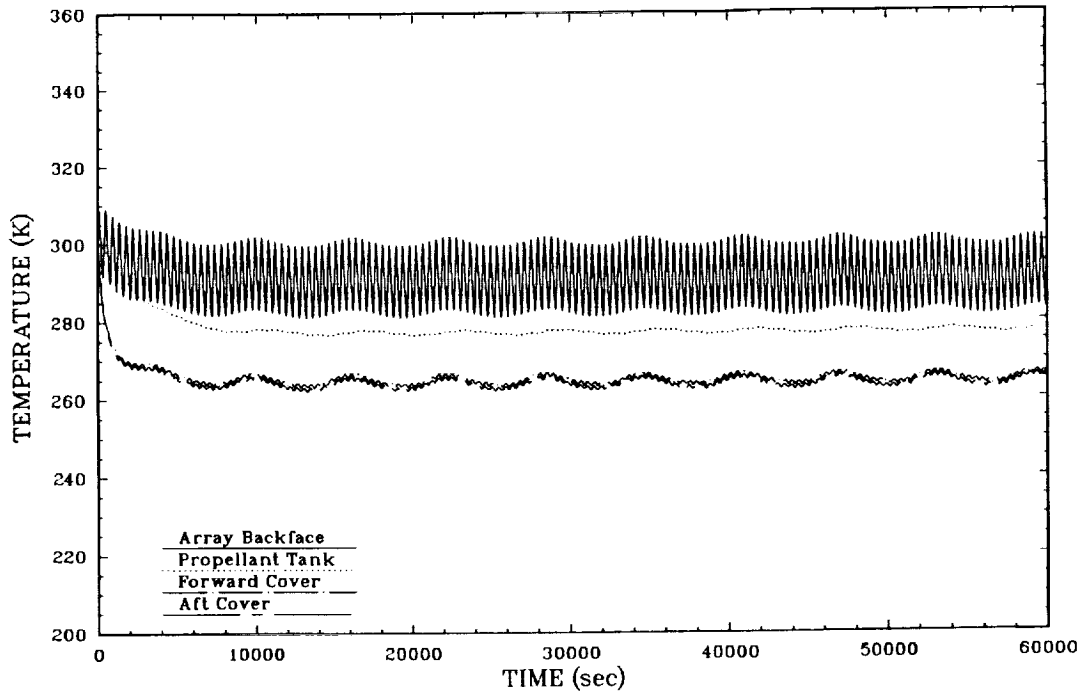

Figure 6-7. Total Absorbed Flux (Solar + Albedo + Earth IR) at Extended Module Aft Cover Surface During One Orbital Period for DRM-5, Summer Solstice, Normal Rotation and Gravity Gradient Vehicle Orientations.

DRM-3, Vernal/Autumnal Equinox  
Normal Rotation = 7.0 RPM, Axial Rotation = 0.14 RPM



DRM-3, Vernal/Autumnal Equinox  
Gravity Gradient, Axial Rotation = 0.14 RPM

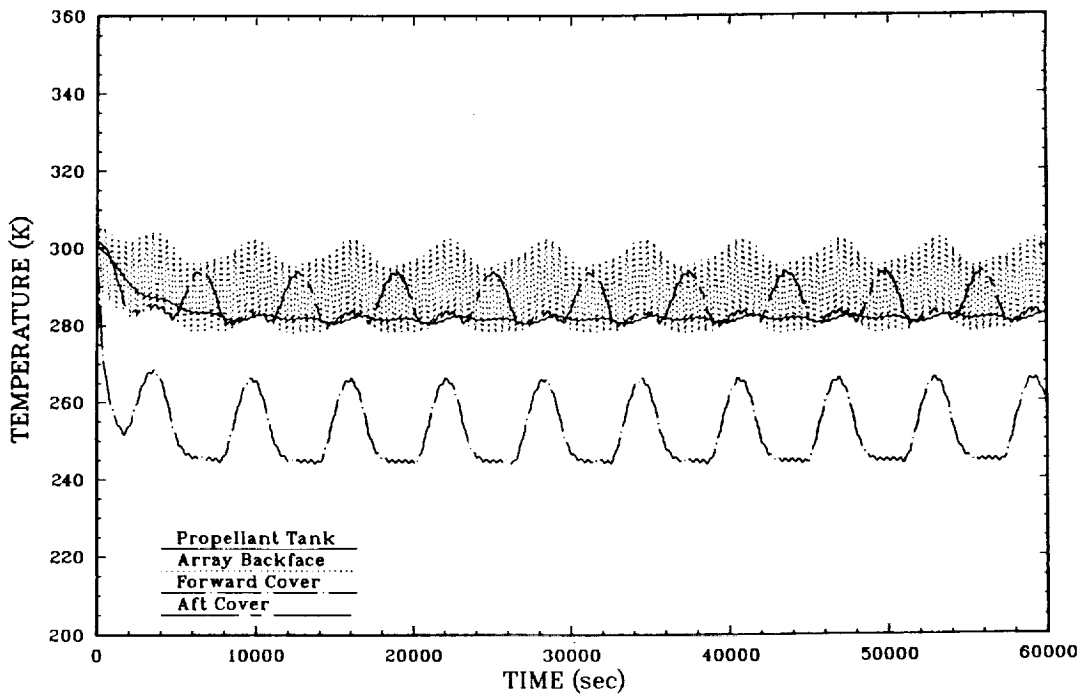
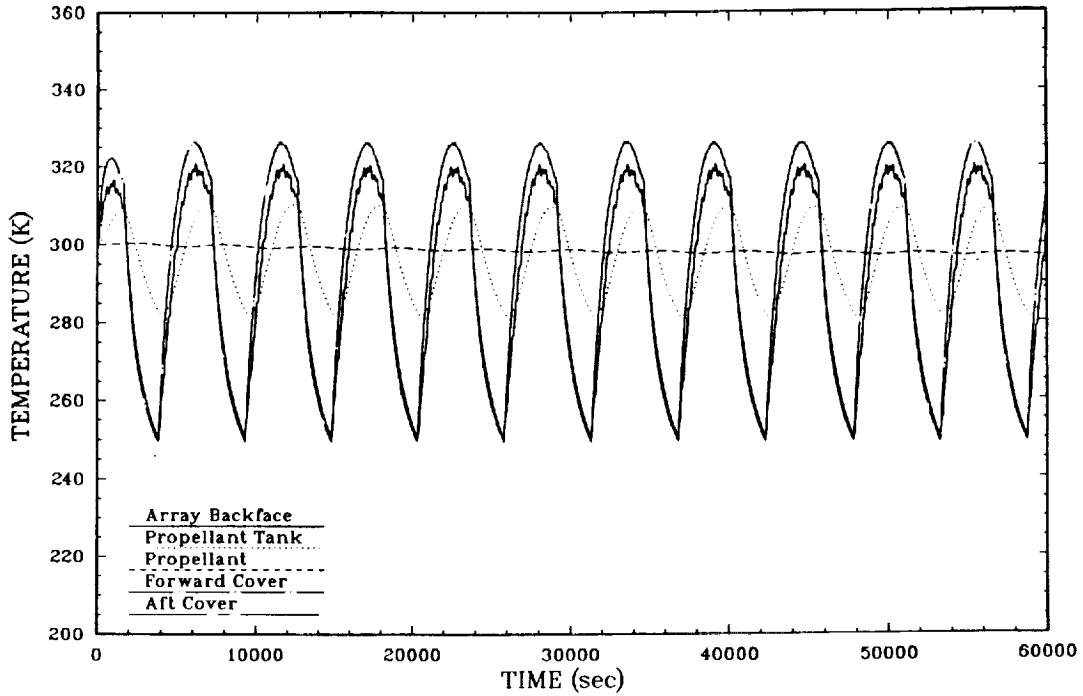

Figure 6-8. Predicted Temperature Response of Extended Module for DRM-3, Vernal/Autumnal Equinox, Normal Rotation and Gravity Gradient Vehicle Orientations.



DRM-5, Summer Solstice  
 Normal Rotation = 7.0 RPM, Axial Rotation = 0.14 RPM



DRM-5, Summer Solstice  
 Gravity Gradient, Axial Rotation = 0.14 RPM

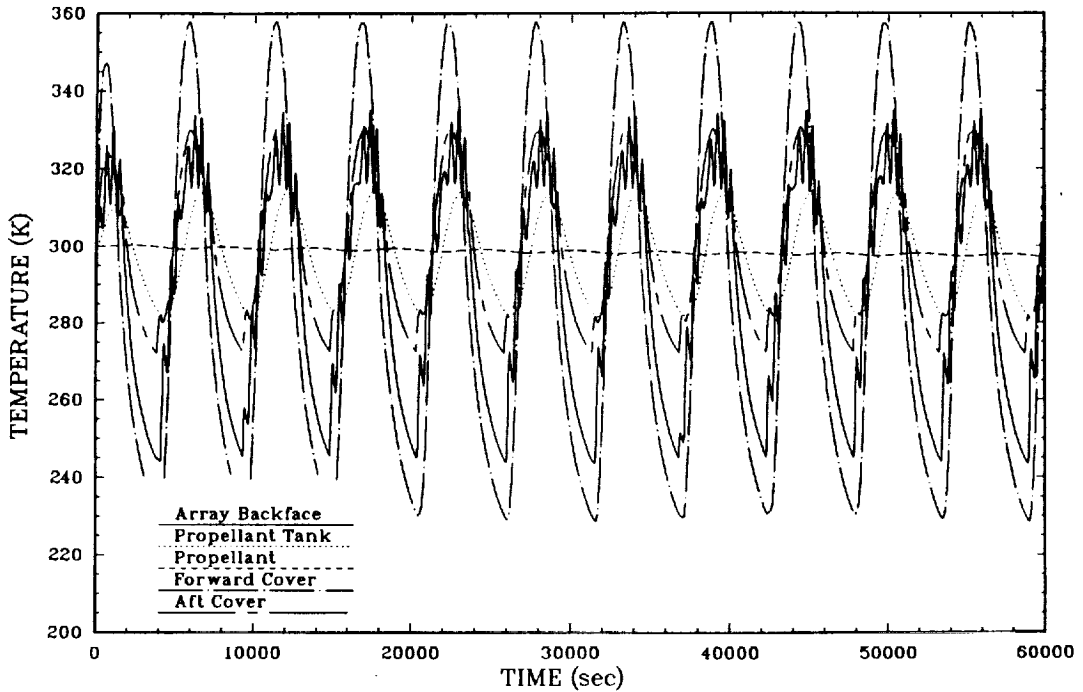

Figure 6-9. Predicted Temperature Response of Extended Module for DRM-5, Summer Solstice, Normal Rotation and Gravity Gradient Vehicle Orientations.

## 7.0 PAYLOAD MODULE WATER SUPPLY THERMAL RESPONSE

Three cylindrical tanks reside within the RRS forward module, each containing approximately 20 kilograms of water. The tanks are situated concentrically about the PM as shown in Figure 7-1. The total quantity of water stored is sufficient to sustain a population of 18 rodents for 60 days. Since the water is stored in liquid form, it must remain above 273 K throughout all anticipated RRS missions. The following addresses the design issue of whether or not active heaters are required to maintain the water above this temperature.

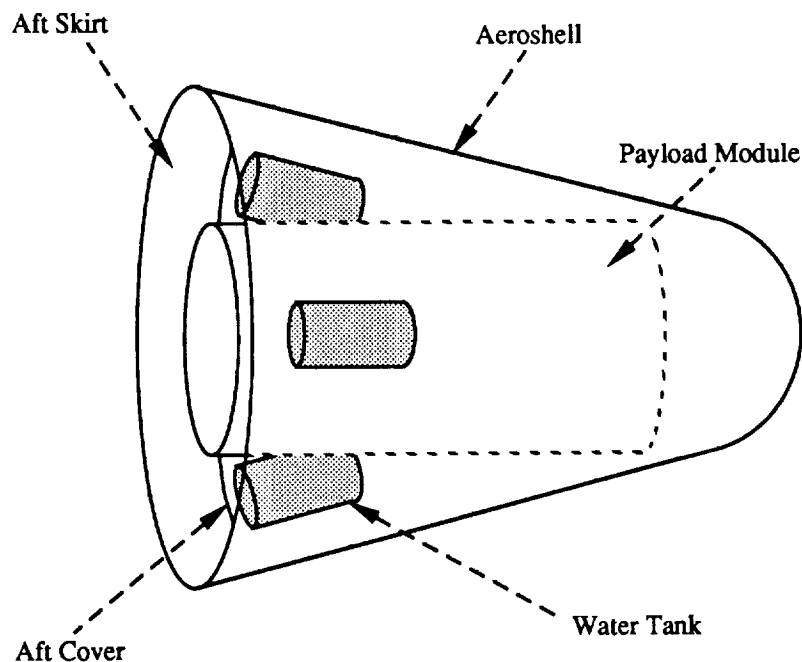

Figure 7-1. Water Storage Tank Locations Within Forward Module.

While in orbit, the tanks experience both radiative and conductive exchange with their surroundings. However, conductive heat transfer will be minimized because of the relatively small cross-sectional areas of the brackets used to secure the tanks to the aeroshell substructure. Therefore, it may be assumed that radiative, rather than conductive exchange, will be the dominant mode of heat transfer for the water tanks.

An examination of Figure 7-1 shows that the primary radiating surfaces, which constitute the forward module's internal cavity and experience some form of thermal forcing function,

whether it be internal (rodents and electronics) or external (solar insolation), are the exterior of the payload module and the insulated backface of the aeroshell substructure. The oxygen and air tanks that bound each water tank can be ignored since they experience the same thermal environment as the water tanks and will, therefore, equilibrate to the same temperature, neutralizing radiant exchange.

Mission requirements dictate that the temperature of the PM interior range between 299 and 291 K. The analysis described in Section 5.0 indicates that the temperature of the aeroshell substructure will fall somewhere between 284 and 281 K. Since radiative exchange is dominant and the PM and aeroshell substructure surfaces essentially encompass the water tanks, the temperature of the tanks will equilibrate between these two limits. Since the lower limit, the substructure temperature, is well above 273 K, it is concluded that no active heating of the water tanks will be necessary.

## References

1. "A Conceptual Design Study of the Reusable Reentry Satellite," NASA Technical Memorandum TM 101043, NASA Ames Research Center, Moffet Field, California, October 1988.
2. "Statement of Work for a Phase B Study of a Reusable Reentry Satellite", NASA Request for Proposal 9-BE2-23-8-48P, NASA Johnson Space Center, Houston, Texas, January 10, 1989.
3. Wassel, A. T., D. C. Bugby, A. L. Laganelli, and C. E. Wallace, "Hypersonic-Vehicle Structural, Thermal and Acoustic Management (HYSTAM) Program," SAIC Report No. SAIC-90/1208, SAIC, Torrance, California, 1989.
4. Duncan, T. C., J. L. Farr, F. T. Makowski, and A. T. Wassel, "Satellite Laser Vulnerability Model: Thermal Analysis Module," SAIC Report No. SAI-060-80R-073-LA, SAIC, Torrance, California, 1980.