

Reusable Reentry Satellite (RRS) Summary Report

Propulsion System Trade Study

April 1990

**Contract NAS9-18202
DRL 02**

Prepared for:

**National Aeronautics and Space Administration
Lyndon B. Johnson Space Center
Houston, Texas 77058**



Science Applications International Corporation

21151 Western Avenue • Torrance, California 90501 • (213) 781-9022

FOREWORD

The Reusable Reentry Satellite (RRS) Propulsion System Trade Study described herein was performed during Part 1 of the RRS Phase B contract. This report is one of several that describes the results of various trade studies performed to arrive at a recommended design for the RRS satellite system. The overall RRS Phase B study objective is to design a relatively inexpensive satellite to access space for extended periods of time, with eventual recovery of experiments on Earth. The RRS will be capable of: 1) being launched by a variety of expendable launch vehicles, 2) operating in low earth orbit as a free-flying unmanned laboratory, and 3) executing an independent atmospheric reentry and soft landing. The RRS will be designed to be refurbished and reused up to 3 times a year for a period of 10 years. The expected principal use for such a system is to research the effects of variable gravity (0-1.5 g) and radiation on small animals, plants, lower life forms, tissue samples, and materials processes.

This summary report describes the RRS Propulsion System Trade Study performed to select an appropriate propulsion system design for the RRS. The weight, performance, reliability and complexity of a wide range of different propulsion systems were compared to select an optimum system for the RRS based on its unique set of requirements.

The Propulsion System Trade Study was performed under the contract technical direction of Mr. Robert Curtis, SAIC Program Manager. The study was directed by Mr. Steve Apfel who was assisted by Ms. Chris Scheil, both of SAIC. Mr. Michael Richardson, JSC New Initiatives Office, provided the RRS objectives and policy guidance for the performance of these tasks under the NAS 9-18202 contract.

CONTENTS

Section	Page
FOREWORD	i
CONTENTS	ii
LIST OF FIGURES	iii
LIST OF TABLES	iii
LIST OF ACRONYMS.....	iv
EXECUTIVE SUMMARY	1
1.0 INTRODUCTION.....	2
1.1 Background.....	2
1.2 NASA JSC Statement of Work Task Definition	2
1.3 Scope.....	3
2.0 STUDY APPROACH.....	4
2.1 Organization	4
2.2 Document Format.....	4
3.0 PURPOSE.....	4
4.0 GROUND RULES AND ASSUMPTIONS	5
5.0 ANALYSIS METHODOLOGY	6
6.0 TOP-LEVEL SYSTEM TRADES	6
6.1 Solid vs. Liquid System	6
6.2 Jettisonable Propulsion Module.....	8
6.3 Thruster Firing Direction.....	9
7.0 LIQUID SYSTEM DESIGN DATA	10
7.1 Propellant Consumption and System Sizing.....	10
7.1.1 Propellant Consumption	10
7.1.2 Propellant Tank Sizing	19
7.2 Propellant Management Devices	19
7.3 Residuals.....	20
7.4 Number of Engines and Layout.....	21
8.0 PROPULSION SYSTEM DESIGN OPTIONS	21
8.1 Monopropellant System.....	22
8.2 Bipropellant System	23
8.3 Dual-Mode Bipropellant System	24
8.4 LO ₂ /LH ₂	25
8.5 Advanced Technology Propulsion System	25
9.0 TRADE STUDY RESULTS	27
10.0 CONCLUSIONS / RECOMMENDATIONS	28

LIST OF FIGURES

Figure		Page
8-1	Monopropellant Propulsion System Schematic.....	22
8-2	Bipropellant Propulsion System Schematic.....	23
8-3	Dual Mode Propulsion System Schematic.....	24

LIST OF TABLES

Table		Page
4-1	RRS Design Reference Missions.....	6
7-1	Monopropellant Propellant Budget – Blowdown.....	11
7-2	Monopropellant Propellant Budget – Pressure Regulated.....	12
7-3	Bipropellant Budget – Blowdown.....	13
7-4	Bipropellant Budget – Pressure Regulated.....	14
7-5	Dual Mode Propellant Budget – Blowdown.....	15
7-6	Dual Mode Propulsion System – Pressure Regulated.....	16
7-7	Dual Mode Advanced Design Propellant Budget.....	17
7-8	Gaseous Oxygen/Hydrogen Propellant Budget.....	18
8-1	Propulsion System Dry Weights in Lbs.	26
9-1	Propellant Usage by System for Selected Deorbit Delta-Vs.....	27

LIST OF ACRONYMS

ACS	Attitude Control System
DRM	Design Reference Mission
ETR	Eastern Test Range
GN&C	Guidance, Navigation, and Control
JSC	Johnson Space Center
PM	Payload Module
PMD	Propellant Management Device
RRS	Reusable Reentry Satellite
RRV	Reusable Reentry Vehicle
SAIC	Science Applications International Corporation
SDI	Strategic Defense Initiative
SRD	System Requirements Document
TPM	Thrust Pulse Modulation
WSMR	White Sands Missile Range
WTR	Western Test Range

EXECUTIVE SUMMARY

The purpose of the RRS Propulsion System Trade Study described in this summary report was to investigate various propulsion options available for incorporation on the RRS and to select the option best suited for RRS application. The design requirements for the RRS propulsion system were driven by the total impulse requirements necessary to operate within the performance envelope specified in the RRS System Requirements Documents. These requirements were incorporated within the Design Reference Missions (DRMs) identified for use in this and other subsystem trade studies. This study investigated the following propulsion systems: solid rocket, monopropellant, bipropellant (monomethyl hydrazine and nitrogen tetroxide or MMH/NTO), dual-mode bipropellant (hydrazine and nitrogen tetroxide or N_2H_4/NTO), liquid oxygen and liquid hydrogen (LO_2/LH_2), and an advanced design propulsion system using SDI-developed components.

Operational considerations such as jettisonable modules, thruster firing direction, and propellant management systems were investigated in addition to performance, weight, cost, complexity, and refurbishment trades for the systems listed above. Strawman system designs were constructed for each system and systematically compared.

A liquid monopropellant blowdown propulsion system was found to be best suited for meeting the RRS requirements and is recommended as the baseline system. This system was chosen because it is the simplest of all investigated, has the fewest components, and is the most cost effective. The monopropellant system meets all RRS performance requirements and has the capability to provide a very accurate deorbit burn which minimizes reentry dispersions. In addition, no new hardware qualification is required for a monopropellant system. Although the bipropellant systems offered some weight savings capability for missions requiring large deorbit velocities, the advantage of a lower mass system only applies if the total vehicle design can be reduced to allow a cheaper launch vehicle to be used. At the time of this trade study, the overall RRS weight budget and launch vehicle selection were not being driven by the propulsion system selection. Thus, the added cost and complexity of more advanced systems did not warrant application.

1.0 INTRODUCTION

1.1 Background

As currently conceived, the Reusable Reentry Satellite (RRS) will be designed to provide investigators in several biological disciplines with a relatively inexpensive method of access to space for up to 60 days with eventual recovery on Earth. The RRS will be designed to permit totally intact, relatively soft recovery of the vehicle, system refurbishment, and re-flight with new and varied payloads. The RRS system will be capable of 3 re-flights per year over a 10-year program lifetime. The RRS vehicle will have a large and readily accessible volume near the vehicle center of gravity for the Payload Module (PM) containing the experiment hardware. The vehicle is configured to permit the experimenter late access to the PM prior to launch and rapid access following recovery.

The RRS will operate as a free-flying spacecraft in orbit and be allowed to drift in attitude to provide an acceleration environment of less than 10^{-5} g. The acceleration environment during orbital trim maneuvers will be less than 10^{-3} g. The RRS is also configured to spin at controlled rates to provide an artificial gravity of up to 1.5 Earth g. The RRS system will be designed to be rugged, easily maintainable, and economically refurbishable for the next flight. Some systems may be designed to be replaced rather than refurbished if system replacement is cost effective and able to meet the specified turnaround time. The minimum time between recovery and re-flight will be approximately 60 days. The PMs will be designed to be relatively autonomous with experiments that require few commands and limited telemetry. Mass storage if needed will be accommodated in the PM. The hardware development and implementation phase is expected to begin in 1991, with a first launch in 1993.

Numerous trade studies and RRS functional design descriptions are required to define a viable RRS concept that satisfies the requirements. NASA has contracted with Science Applications International Corporation (SAIC) to perform a Phase B study to provide the RRS concept definition. The Propulsion System Trade Study described in this report is one of the supporting study analyses performed by the SAIC team.

1.2 NASA JSC Statement of Work Task Definition

The reentry propulsion system trade study was performed per the general direction of the RRS Statement of Work and the System Requirements Document (SRD) as given in the following paragraphs:

General:

SOW Paragraph 3.1.2 Tradeoff Studies: "Conduct required tradeoff studies for each of the areas and options listed below as well as others identified in the contractor's proposal or which become apparent during the course of the study effort. The depth of analysis for each individual option will vary as appropriate to clarify and document the viability of each approach. In all of the following tradeoffs, particular attention should be given to effects on the complexity, flexibility, or imposed constraints on the RRS design, RM design, or mission operations. Also, special consideration should be given to system reliability and operational safety as well as the reduction in program life cycle costs."

Specific:

SRD Paragraph 3.3.6 Attitude Control and Propulsion Subsystem: "The RRS Attitude Control and Propulsion Subsystem shall provide the following capabilities:

- (a) Perform attitude determination, stabilization, and control functions as required throughout the orbital phase of a mission.
- (b) Control RRS attitude rates as specified in Paragraph 3.2.3.3 (on-orbit acceleration limits).
- (c) Provide the necessary velocity changes for the deorbit maneuvers.
- (d) Spin up and maintain the RRS at various rates to satisfy experiment requirements for fractional g levels. Provide capability to despin for microgravity levels in the same flight.
- (e) If required, spin up to TBD rpm for the deorbit thrust maneuver, and spin down to TBD rpm for reentry.
- (f) Correct launch errors in the orbital parameters and adjust the parameters to be compatible with the recovery site requirements."

1.3 Scope

This NASA Phase B study is intended to provide definition of the RRS concept. The study includes tradeoff studies with the depth of analysis as appropriate to clarify and document the viability of each approach. The RRS system and operations are developed to the degree necessary to provide a complete description of the designs and functional specifications. The propulsion system trade described in this report was performed to ensure that the SAIC RRS design meets all mission requirements yet remains as simple and cost effective as possible.

2.0 STUDY APPROACH

2.1 Organization

The tradeoff analyses performed in Part 1 of the RRS Phase B study were organized to be accomplished in a series of related but separate tradeoff studies and system concept definitions. Therefore, the documentation described in these summary reports has been formatted to accommodate a compendium of analyses published in several separate documents. Because of the synergistic nature of one tradeoff study across the entire RRS system design, it is suggested that the reader review all summary reports in order to get a complete picture of the SAIC RRS design.

2.2 Document Format

Individual analyses and studies do not necessarily lend themselves to be documented in exactly the same way; however, a general outline has been used where reasonable for all reports. The guideline for preparing the individual study sections in this and all summary reports is provided below:

- Purpose
- Groundrules and Assumptions
- Analysis Description
- Analysis Results
- Conclusions
- Recommendations

3.0 PURPOSE

The purpose of the RRS Propulsion System Trade Study was: 1) to investigate various propulsion options available and 2) to select the option best suited for RRS application. During the performance of this task, the weight, performance, reliability and complexity of a wide range of propulsion systems were compared and analyzed. Data for the selected system was then used in other trade studies in order to develop the design definition of the SAIC RRS concept.

4.0 GROUND RULES AND ASSUMPTIONS

The overall requirements of the RRS propulsion system were discussed in Section 1.2 as stated in the RRS SRD. In general, the RRS propulsion system will be used to supply all major velocity increments and vehicle attitude adjustments after separation from the launch vehicle. The system must be capable of providing highly accurate total impulse delivery in order to meet the landing dispersion requirements. Since the propulsion system is one of the critical items for reentry safety, the design must be fail operational / fail safe. The propulsion system, coupled with the Guidance, Navigation and Control (GN&C) and power system redundancy, provides no single-point failures in achieving a safe landing of the RRS with minimal safety hazard to the public. The propulsion system must also deliver highly accurate total impulse as commanded by the GN&C system, again to ensure that the landing dispersions are minimal.

The propulsion system must also provide impulses to spin up the vehicle for artificial gravity missions. The limit of this impulse, determined by analyses discussed in the RRS Configuration Summary Report, must be less than 1 lbf of thrust in order to prevent overstressing the Astromasts in their extended configuration.

From a science requirements perspective, the RRS propulsion system (and of course an appropriate control system) must be capable of controlling on-orbit acceleration of the PM to provide either a fractional gravity or a microgravity environment. The fractional gravity environment will subject experimental specimens to a steady artificial gravity acceleration of up to 1.5 g. The artificial gravity level will be selectable at any value between 0.1 g and 1.5 g for any flight and will be maintained within a range of $\pm 10\%$. The microgravity environment will subject experimental specimens to an artificial gravity acceleration level which is less than 10^{-5} g for at least 95% of the Orbital Flight Phase. During the remainder of the flight, the artificial gravity acceleration level shall not exceed 10^{-3} g.

The propulsion system performance and tank sizing calculations discussed in this report were performed using the design reference missions defined early in the study and shown in Table 4-1 as reference. The remaining general groundrule that was used in the propulsion system trade was the desire to make the system as simple and cost effective as possible. To minimize development cost, space-qualified hardware was investigated and incorporated in designs studied whenever possible.

Table 4-1. RRS Design Reference Missions

Definition Parameter	Design Reference Mission Set				
	DRM-1	DRM-2	DRM-3	DRM-4	DRM-5
Character	Land Recovery	High Altitude	High Inclination	Integer Orbits	Water Recovery
Inclination	33.83°	33.83°	98°	35.65°	28.5°
Orbit Type	Circular	Circular	Circular, Near-Integer	Circular, Integer	Circular
Orbit Altitude	350 km (189 nm)	900 km (486 nm)	897 km (484 nm)	479 km (259 nm)	350 km (189 nm)
Launch Site	Eastern Test Range (ETR)	ETR	WTR	ETR	ETR
Recovery Site	White Sands Missile Range (WSMR)	WSMR	WSMR	WSMR	Water (ETR, Gulf of Mexico, WTR)

5.0 ANALYSIS METHODOLOGY

The analysis methodology used for the propulsion trade studies consisted of several phases of analysis. The design requirements were determined by the DRMs (total impulse required) and the design goals of the SAIC design. Top-level design goals were sufficient to perform a general evaluation of potential types of propulsion systems that could be adapted for RRS application. The purpose of this top-level screening was to determine the pros and cons of each type of system relative to RRS system requirements. After evaluating these parameters and selecting a general system type, a more detailed investigation of the option was performed. Specific issues were investigated and traded such as performance, weight, cost, complexity, and refurbishment potential. Operational considerations such as jettisonable modules, thruster firing direction and propellant management systems were also investigated. Final recommendations for the baseline RRS propulsion system were made at the conclusion of the study and discussed in this report.

6.0 TOP-LEVEL SYSTEM TRADES

6.1 Solid vs. Liquid System

The first propulsion system trade performed was to select the overall type of system (solid or liquid) best suited for RRS application. The RRS Ames Phase A study recommended a propulsion system that included three STAR 17 solid rocket motors for the main deorbit burn along with a monopropellant hydrazine system for attitude control, spin control and general trim burns.

The solid rocket motor deorbit system studied during Phase A provides relatively inexpensive impulse for the deorbit maneuver; however, a number of performance limitations are inherent in its use. The total delivered impulse accuracy for solid motors is $\pm 0.5\%$. This number is driven by motor temperature differences as well as motor to motor variations. Providing accurate total impulse with this type of system requires a thrust termination system to shut off the solids, which is not trivial. The incorporation of the hydrazine liquid system, required for spin speed control and ACS, could be used to take out impulse errors associated with the solid rocket system, but this solution requires two systems to perform a single function.

The motor-to-motor differences mentioned above also relate to differences in delivered thrust. Averaging these differences requires either gimbaling the solid motor exit cones or spinning the vehicle to average out the differences. Gimbaling of exit cones is performed on large solids for launch vehicles and orbit transfer stages. However, it is expensive (\$millions) and would require design modifications be made to the STAR 17 motor. Spinning the vehicle, as well as the solid motor burn itself, impose accelerations (2 to 3 g for the deorbit burn, 0.5 to 0.75 g for the spinning maneuver at 30 rpm) in a direction different from other phases of the flight. The SAIC design goal is to try to maintain the acceleration forces in the same direction for all phases of flight.

From a reusability and refurbishment standpoint, solid motors have to be replaced after each flight. The motor cases might be reusable, but the overall cost savings would be minimal. Solid rocket motors are designed and loaded to deliver a total impulse. This makes a given motor mission specific. Different reentry requirements, due to different orbital altitudes, would require different motors for each mission. Operationally this would mean different motors must be kept on hand at the refurbishment site to meet the 60-day re-flight capability. Finally, and most importantly, the solid system does not meet the fail operational/fail safe design goal of the SAIC design. A solid motor failure could greatly increase the landing dispersions (and it is questionable if the vehicle would reenter at all) due to the loss of a large percentage of the total impulse and coning of the vehicle induced by the thrust imbalance. Such occurrences may not be correctable, thus creating a potential safety hazard.

Liquid propulsion systems, on the other hand, have higher initial cost compared to a solid systems, but are reusable and provide much more flexibility. The liquid systems pulse capability allows it to be tied into the attitude control system. This, coupled with accurate total impulse accuracies ($< \pm 0.01\%$) and various control techniques (e.g., active nutation), can minimize

dispersion error sources inherent in the propulsion system. Such a system has the potential to provide very accurate deorbit burns. A liquid system also has the potential to perform a trim burn before reentry interface as an added safety backup. From a safety perspective, liquid systems for satellites typically are designed with fail operational/ fail safe capability. This takes the form of redundant engines and dual coil valves.

For the above reasons, it was decided that a liquid deorbit propulsion system was much more desirable for RRS application than a solid system postulated in Phase A. The inherent capability to combine the attitude control system with the main system was also a benefit. Further discussion on the evolution of the liquid system proposed for the RRS is given in subsequent sections.

6.2 Jettisonable Propulsion Module

The proposal configuration for the SAIC design concept incorporated a jettisonable propulsion module. The module served as the interface connection plane to the launch vehicle and housed structural and subsystem components for the propulsion system. The module remained attached to the RRS until completion of the deorbit burn, at which time it was jettisoned to reenter separately from the RRS. The rationale for this design was that it allowed for easier structural interfaces with the launch vehicle and was a simple way to implement forward firing thrusters. Forward firing thrusters were desired in order to maintain a monodirectional acceleration force on the vehicle at all times during the mission, as discussed in Section 6.1. The thrusters required to perform in this manner were located outside the radius of the RRS heat shield with exit cones oriented towards the nose of the RRS (i.e., forward firing).

This concept was subsequently modified for two reasons. The first was the inability to positively quantify that there would not be a public safety hazard using this concept. The propulsion module will contain components that may not burn up during reentry, thus creating a potential safety hazard. A potential solution to this problem was investigated that entailed spinning up the propulsion module after separation from the vehicle and firing its main engines one or more times to ensure that the propulsion module debris footprint falls over water only. This spun configuration would require a simple control system, possibly as simple as a set of timers. However, the major detractor from this approach was the unknown impact relative to the propulsion system design. Different orbits and landing sites could have a large impact on the total velocity increment required to perform the safe reentry of the propulsion module. The analysis and

testing required to verify the propulsion module reentry footprint and to determine its effect on the propulsion system design was felt to impact the RRS program too much to be considered further.

The second reason the original concept was modified was the cost associated with replacement of the propulsion module for each flight. Depending on the type of propulsion selected, the cost of the module could range from \$2 to \$4 million each. Life cycle cost impacts of \$50 to \$110 million could be accrued over a lifetime of 30 flights. Even though this amount is small compared with the launch costs of each flight, it was felt to be of importance nevertheless. For these reasons, the decision was made to make the propulsion system integral with the vehicle.

6.3 Thruster Firing Direction

As discussed briefly above, the proposal also called for deorbit thruster firings towards the nose of the vehicle in order to maintain all accelerations in the same direction during all phases of the mission. The forward firing thrusters also provided a means of safely deorbiting the vehicle in the event of an Astromast failure to retract. The deorbit maneuver could still be performed as the masts would be in tension, "pulling" the main module. Since the masts do not have sufficient bending stiffness to allow "pushing" the main module, this concept was preferred at the time. This design also assumed a jettisonable propulsion module as discussed in the previous section. Since early propulsion module trades determined that the module should be integral to the vehicle, direct forward firing thrusters now presented a slightly different design problem.

Various design options were proposed and investigated to maintain the unidirectional g feature in the design including thruster cavities (nozzles) in the aft end of the heat shield, retractable booms and partial retraction of the Astromasts. In general, all concepts were found to be possible but were considered high risk in terms of development and/or reliability. Subsequent discussions with life science personnel about the desire to keep the unidirectional g feature vs design complexities resulted in a compromise baseline of more conventional aft firing thrusters being used for the deorbit burn. The scientists considered the reversal of g load direction during the deorbit maneuver noncritical considering the time and magnitude of the burn (250 seconds maximum at less than 0.3 g) proposed by the SAIC design. Thus a conventional approach of mounting the main deorbit thrusters on the rear face of the vehicle was adopted.

7.0 LIQUID SYSTEM DESIGN DATA

This section describes the kinds of data collected and provides scoping calculations performed to devise various propulsion systems, described in Section 8, which were evaluated for RRS application. Section 9 provides trade study results.

7.1 Propellant Consumption and System Sizing

7.1.1 Propellant Consumption

The propulsion system was sized assuming a 350 m/sec (1148 ft/sec) deorbit burn from the high altitude (DRM-3) case. This maneuver provides enough total impulse to bring the vehicle down at a relatively steep angle from a 900 kilometer orbit in order to minimize dispersions. The system was also designed to provide margins for nominal missions that may require orbit adjustments to optimize the ground track for reentry. Miscellaneous velocity increments (other than deorbit and spinup/spindown) were estimated based on drag, vehicle configuration, outgassing and orientation requirements. This maneuver history, along with estimated vehicle mass properties and typical engine performance (Isp) values, was input to a simple spreadsheet model that calculated total propellant load required for various types of propulsion systems investigated. The calculations were performed for a monopropellant, bipropellant (monomethyl hydrazine and nitrogen tetroxide or MMH/NTO), dual-mode bipropellant (hydrazine and nitrogen tetroxide or N_2H_4/NTO), liquid oxygen and liquid hydrogen (LO_2/LH_2) and an advanced design propulsion system using SDI-developed components. The propellant load calculations for a single case for each system (pressurized and blowdown where applicable) are shown in Tables 7-1 through 7-8.

Table 7-1 shows the propellant budget for a monopropellant blowdown propulsion system. This case documents a 350 m/sec (1148 ft/sec) deorbit burn or a fully loaded case. The first column gives the maneuver type, the next the magnitude in ft/sec for linear motion, RPM if it is a spin up or down and degrees for reorientation of the vehicle. The next two columns give the specific impulse, or Isp, and the duration for the maneuver. The total fuel consumed and launched mass are given next with the final columns displaying moments of inertia in two planes and finally comments. The bottom rows give details on the engine characteristics including the number of engines and representative performance at pressure.

Table 7-1. Monopropellant Propellant Budget - Blowdown

MANEUVER	MANEUVER MAGNITUDE FT/SEC,RPM, DEGREES	ISP (sec)	TIME (sec)	FUEL USED (lb)	VEHICLE MASS (lbs)	INERTIA Z-Z (Slug Ft ²)	INERTIA X-X (Slug Ft ²)	COMMENTS
Separated mass				624.2	3618.4			
orient	90.0 deg	140	21.7	0.2	3618.3	560.0	196.0	NULL LAUNCH VEHICLE TIP OFF ERRORS
spin up z-z	0.0 rpm	225		0.0	3618.3			OPTION IF NO THRUST PULSE MODULATION
circularize	25.0 ft/sec	235		11.9	3606.3			REMOVAL OF LAUNCH INJECTION ERRORS
ANC	0.0 ft/sec	200		0.0	3606.3			USED IF SPUN - PREVENT FLAT SPIN
spin down	0.0 rpm	225		0.0	3606.3			
orient	270.0 deg	140	37.5	0.3	3606.1	560.0	196.0	ORIENT FOR MAST EXTENSION
spin up x-x	9.5 rpm	220	5680.0	25.5	3580.5	284000.0		SPIN UP TO 1.5 G
out gassing	0.0 ft/sec	140		0.0	3580.5	283750.0		SPIN AND ORBIT CONTROL
spin maint.	3.0 rpm	140		12.7	3567.8	283750.0		DUE TO DRAG AND OTHER FORCES
attitude maint.	0.0 ft/sec	140		0.0	3567.8	283750.0		FOR THERMAL AND OR POWER CONTROL
drag makeup	15.0 ft/sec	140		11.9	3556.0	283720.0		FACTOR OF SURFACE AREA AND ALTITUDE
despin	9.5 rpm	220		25.5	3530.5	283500.0		SPIN DOWN
orient	180.0 deg	140	30.6	0.2	3530.2	560.0		NULL RATES ORIENT FOR MAST RETRACTION
spin up	0.0 rpm	215		0.0	3530.2			OPTION IF NO TPM
orbit maint.	45.0 ft/sec	225		21.9	3508.4			ALIGN ORBIT FOR REENTRY
ANC	0.0 ft/sec	140		0.0	3508.4			IF SPIN
deorbit	1148.0 ft/sec	225		514.1	2994.3			
orient and hold	300.0 deg	140	38.1	0.3	2994.0	520.0		SET UP FOR ATMOSPHERIC ENTRY
Empty Mass					2994.0			

ASSUMPTIONS:	THRUST (lbs)	ISP @300 PSI	TOTAL #	# USED main	# USED OTHER	BLOWDOWN (PSI)
ACS ENGINES	0.5	225	12.0	4.0	8.0	350-75
MAIN ENGINES	100.0	235	6.0	6.0		350-75

Table 7-2. Monopropellant Propellant Budget – Pressure Regulated

MANEUVER	MANEUVER MAGNITUDE (Ft/sec, rpm, Degrees)	ISP (sec)	TIME (sec)	FUEL USED (lb)	VEHICLE MASS (lbs)	INERTIA Z-Z (Slug Ft ²)	INERTIA X-X (Slug Ft ²)	COMMENTS
Separated mass				594.84	3565.1			
orient	90.0 deg	140	21.7	0.15	3565.0	560.0	196.0	NULL LAUNCH VEHICLE TIP OFF ERRORS OPTION IF NO THRUST PULSE MODULATION
spin up z-z	0.0 rpm	225		0.00	3565.0			REMOVAL OF LAUNCH INJECTION ERRORS USED IF SPUN - PREVENT FLAT SPIN
circularize	25.0 ft/sec	235		11.76	3553.2			
ANC	0.0 ft/sec	200		0.00	3553.2		196.0	
spin down	0.0 rpm	225		0.00	3553.2			
orient	270.0 deg	140	37.5	0.27	3552.9	560.0		ORIENT FOR MAST EXTENSION
spin up x-x	9.5 rpm	225	5618.1	24.97	3528.0	284000.0		SPIN UP TO 1.5 G
out gassing	0.0 ft/sec	140		0.00	3528.0	283750.0		SPIN AND ORBIT CONTROL
spin maint.	3.0 rpm	140		12.73	3515.2	283750.0		DUE TO DRAG AND OTHER FORCES
attitude maint.	0.0 ft/sec	140		0.00	3515.2	283750.0		FOR THERMAL AND OR POWER CONTROL
drag makeup	15.0 ft/sec	140		11.68	3503.6	283720.0		FACTOR OF SURFACE AREA AND ALTITUDE
despin	9.5 rpm	225		24.93	3478.6	283500.0		SPIN DOWN
orient	180.0 deg	140	30.6	0.22	3478.4	560.0		NULL RATES ORIENT FOR MAST RETRACTION
spin up	0.0 rpm	220		0.00	3478.4			OPTION IF NO TPM
orbit maint.	45.0 ft/sec	225		21.54	3456.9			ALIGN ORBIT FOR REENTRY
ANC	0.0 ft/sec	140		0.00	3456.9			IF SPIN
deorbit	### ft/sec	235		486.60	2970.3			
orient and hold	300.0 deg	140	38.1	0.27	2970.0	520.0		SET UP FOR ATMOSPHERIC ENTRY
Empty Mass					2970.0			
594.8								

ASSUMPTIONS:	THRUST (lbs)	ISP '@300 PSI	TOTAL #	# USED		BLOWDOWN (PSI)
				main	OTHER	
ACS ENGINES	0.5	225	12.0	4.0	8.0	350-75
MAIN ENGINES	100.0	235	6.0	6.0		350-75

Table 7-3. Bipropellant Budget - Blowdown

MANEUVER	MANEUVER MAGNITUDE ft/sec, rpm, degrees	ISP (sec)	TIME (sec)	FUEL USED (lb)	VEHICLE MASS (lbs)	INERTIA Z-Z (Slug Ft ²)	INERTIA X-X (Slug Ft ²)	COMMENTS
Separated mass				177.9	3205.1			
orient	90.0 deg	265	21.7	0.1	3205.0	560.0	196.0	NULL LAUNCH VEHICLE TIP OFF ERRORS OPTION IF NO THRUST PULSE MODULATION
spin up z-z	0.0 rpm	275		0.0	3205.0			REMOVAL OF LAUNCH INJECTION ERRORS USED IF SPUN - PREVENT FLAT SPIN
circularize	25.0 ft/sec	310		8.0	3197.0			
ANC	0.0 ft/sec	250		0.0	3197.0			
spin down	0.0 rpm	275		0.0	3197.0			
orient	270.0 deg	265	37.5	0.1	3196.9	560.0	196.0	ORIENT FOR MAST EXTENSION
spin up x-x	9.5 rpm	280	5618.1	20.1	3176.8	284000.0		SPIN UP TO 1.5 G
out gassing	0.0 ft/sec	240		0.0	3176.8	283750.0		SPIN AND ORBIT CONTROL
spin maint.	3.0 rpm	240		7.4	3169.4	283750.0		DUE TO DRAG AND OTHER FORCES
attitude maint.	0.0 ft/sec	240		0.0	3169.4	283750.0		FOR THERMAL AND OR POWER CONTROL
drag makeup	15.0 ft/sec	265		5.6	3163.8	283720.0		FACTOR OF SURFACE AREA AND ALTITUDE
despin	9.5 rpm	278		20.2	3143.6	283500.0		SPIN DOWN
orient	180.0 deg	265	30.6	0.1	3143.5	560.0		NULL RATES ORIENT FOR MAST RETRACTION
spin up	0.0 rpm	273		0.0	3143.5			OPTION IF NO TPM
orbit maint.	45.0 ft/sec	308		14.2	3129.3			ALIGN ORBIT FOR REENTRY
ANC	0.0 ft/sec	250		0.0	3129.3			IF SPIN
deorbit	328.0 ft/sec	307		102.1	3027.2			
orient and hold	300.0 deg	250	38.1	0.2	3027.0	520.0		SET UP FOR ATMOSPHERIC ENTRY
EMPTY MASS					3027.0			
177.9								

ASSUMPTIONS:	THRUST (lbs)	ISP '@300 PSI	TOTAL #	# USED		BLOWDOWN (PSI)
				main	OTHER	
ACS ENGINES	0.5	280	12.0	4.0	8.0	350-100
MAIN ENGINES	100.0	310	6.0	6.0		350-100

Table 7-4. Bipropellant Budget - Pressure Regulated

MANEUVER	MANEUVER MAGNITUDE (ft/sec, rpm, degrees)	ISP (sec)	TIME (sec)	FUEL USED (lb)	VEHICLE MASS (lbs)	INERTIA Z-Z (slug ft ²)	INERTIA X-X (slug ft ²)	COMMENTS
Separated mass				445.4	3461.6			
orient	90.0 deg	265	21.7	0.1	3461.5	560.0	196.0	NULL LAUNCH VEHICLE TIP OFF ERRORS OPTION IF NO THRUST PULSE MODULATION
spin up z-z	0.0 rpm	275		0.0	3461.5			REMOVAL OF LAUNCH INJECTION ERRORS USED IF SPUN - PREVENT FLAT SPIN
circularize	25.0 ft/sec	310		8.7	3452.8			
ANC	0.0 ft/sec	250		0.0	3452.8			
spin down	0.0 rpm	275		0.0	3452.8		196.0	
orient	270.0 deg	265	37.5	0.1	3452.7	560.0		ORIENT FOR MAST EXTENSION
spin up x-x	9.5 rpm	280	5618.1	20.1	3432.6	284000.0		SPIN UP TO 1.5 G
out gassing	0.0 ft/sec	240		0.0	3432.6	283750.0		SPIN AND ORBIT CONTROL
spin maint.	3.0 rpm	240		7.4	3425.2	283750.0		DUE TO DRAG AND OTHER FORCES
attitude maint.	0.0 ft/sec	240		0.0	3425.2	283750.0		FOR THERMAL AND OR POWER CONTROL
drag makeup	15.0 ft/sec	265		6.0	3419.2	283720.0		FACTOR OF SURFACE AREA AND ALTITUDE
despin	9.5 rpm	280		20.0	3399.2	283500.0		SPIN DOWN
orient	180.0 deg	265	30.6	0.1	3399.0	560.0		NULL RATES ORIENT FOR MAST RETRACTION
spin up	0.0 rpm	275		0.0	3399.0			OPTION IF NO TPM
orbit maint.	45.0 ft/sec	310		15.3	3383.8			ALIGN ORBIT FOR REENTRY
ANC	0.0 ft/sec	250		0.0	3383.8			IF SPIN
deorbit	1148.0 ft/sec	310		367.6	3016.1			
orient and hold	300.0 deg	265	38.1	0.1	3016.0	520.0		SET UP FOR ATMOSPHERIC ENTRY
EMPTY MASS					3016.0			
445.4								

ASSUMPTIONS:	THRUST lbs	ISP @300 PSI	TOTAL #	# USED		BLOWDOWN PSI
				main	OTHER	
ACS ENGINES	0.5	280	12.0	4.0	8.0	350-100
MAIN ENGINES	100.0	310	6.0	6.0		350-100

Table 7-5. Dual Mode Propellant Budget - Blowdown

MANEUVER	MANEUVER MAGNITUDE (ft/sec, rpm, degrees)	ISP (sec)	TIME (sec)	FUEL USED (lbs)	VEHICLE MASS (lbs)	INERTIA Z-Z (slug ft2)	INERTIA X-X (slug ft2)	COMMENTS
Separated mass				202.5	3227.7			
orient	90.0 deg	140	21.7	0.2	3227.5	560.0	196.0	NULL LAUNCH VEHICLE TIP OFF ERRORS OPTION IF NO THRUST PULSE MODULATION
spin up z-z	0.0 rpm	225		0.0	3227.5			REMOVAL OF LAUNCH INJECTION ERRORS
circularize	25.0 ft/sec	314		8.0	3219.5			USED IF SPUN - PREVENT FLAT SPIN
ANC	0.0 ft/sec	200		0.0	3219.5			
spin down	0.0 rpm	225		0.0	3219.5		196.0	ORIENT FOR MAST EXTENSION
orient	270.0 deg	140	37.5	0.3	3219.3	560.0		
spin up x-x	9.5 rpm	220	5618.1	25.5	3193.7	284000.0		SPIN UP TO 1.5 G
out gassing	0.0 ft/sec	140		0.0	3193.7	283750.0		SPIN AND ORBIT CONTROL
spin maint.	3.0 rpm	140		12.7	3181.0	283750.0		DUE TO DRAG AND OTHER FORCES
attitude maint.	0.0 ft/sec	140		0.0	3181.0	283750.0		FOR THERMAL AND OR POWER CONTROL
drag makeup	15.0 ft/sec	140		10.6	3170.4	283720.0		FACTOR OF SURFACE AREA AND ALTITUDE
despin	9.5 rpm	220		25.5	3144.9	283500.0		SPIN DOWN
orient	180.0 deg	140	30.6	0.2	3144.7	560.0		NULL RATES ORIENT FOR MAST RETRACTION
spin up	0.0 rpm	215		0.0	3144.7			OPTION IF NO TPM
orbit maint.	45.0 ft/sec	225		19.5	3125.3			ALIGN ORBIT FOR REENTRY
ANC	0.0 ft/sec	140		0.0	3125.3			IF SPIN
deorbit	328.0 rpm	313		100.1	3025.2			
orient and hold	300.0 deg	205	38.1	0.2	3025.0	520.0		SET UP FOR ATMOSPHERIC ENTRY
EMPTY MASS					3025.0			
202.5								

ASSUMPTIONS:	THRUST lbs	ISP @300 PSI	TOTAL #	#USED main	#USED OTHER	BLOWDOWN PSI
ACS ENGINES	0.5	225	12.0	4.0	8.0	350-75
MAIN ENGINES	100.0	314	6.0	6.0		350-125

Table 7-6. Dual Mode Propulsion System - Pressure Regulated

MANEUVER	MANUEVER MAGNITUDE (ft/sec, rpm, degrees)	ISP (sec)	TIME (sec)	FUEL USED (lbs)	VEHICLE MASS (lbs)	INERTIA Z-Z (slug ft ²)	INERTIA X-X (slug ft ²)	COMMENTS
Separated mass				468.2	3493.4			
orient	90.0 deg	140	21.7	0.2	3493.2	560.0	196.0	NULL LAUNCH VEHICLE TIP OFF ERRORS OPTION IF NO THRUST PULSE MODULATION REMOVAL OF LAUNCH INJECTION ERRORS USED IF SPUN - PREVENT FLAT SPIN ORIENT FOR MAST EXTENSION SPIN UP TO 1.5 G SPIN AND ORBIT CONTROL DUE TO DRAG AND OTHER FORCES FOR THERMAL AND OR POWER CONTROL FACTOR OF SURFACE AREA AND ALTITUDE SPIN DOWN NULL RATES ORIENT FOR MAST RETRACTION OPTION IF NO TPM ALIGN ORBIT FIR REENTRY IF SPIN SET UP FOR ATMOSPHERIC ENTRY
spin up z-z	0.0 rpm	225		0.0	3493.2			
circularize	25.0 ft/sec	314		8.6	3484.6			
ANC	0.0 ft/sec	200		0.0	3484.6			
spin down	0.0 rpm	225		0.0	3484.6			
orient	270.0 deg	140	37.5	0.3	3484.3	560.0	196.0	
spin up x-x	9.5 rpm	225	5618.1	25.0	3459.4	284000.0		
out gassing	0.0 ft/sec	140		0.0	3459.4	283750.0		
spin maint.	3.0 rpm	140		12.7	3446.6	283750.0		
attitude maint.	0.0 ft/sec	140		0.0	3446.6	283750.0		
drag makeup	15.0 ft/sec	140		11.4	3435.2	283720.0		
despin	9.5 rpm	225		24.9	3410.3	283500.0		
orient	180.0 deg	140	30.6	0.2	3410.0	560.0		
spin up	0.0 rpm	220		0.0	3410.0			
orbit maint.	45.0 ft/sec	225		21.1	3388.9			
ANC	0.0 ft/sec	140		0.0	3388.9			
deorbit	1148.0 ft/sec	314		363.7	3025.2			
orient and hold	300.0 deg	205	38.1	0.2	3025.0	520.0		
EMPTY MASS					3025.0			
468.2								

ASSUMPTIONS:	THRUST lbs	ISP @300 PSI	TOTAL #	# USED main	# USED OTHER	BLOWDOWN PSI
ACSENGINES	0.5	225	12.0	4.0	8.0	350-75
MAIN ENGINES	100.0	314	6.0	6.0		350-125

Table 7-7. Dual Mode Advanced Design Propellant Budget

MANEUVER	MANEUVER MAGNITUDE (ft/sec, rpm, degrees)	ISP (sec)	TIME (sec)	FUEL USED (lbs)	VEHICLE MASS (lbs)	INERTIA Z-Z (slug ft ²)	INERTIA X-X (slug ft ²)	COMMENTS
Separated mass				174.6	3077.8			
orient	90.0 deg	150	21.7	0.1	3077.7	560.0	196.0	NULL LAUNCH VEHICLE TIP OFF ERRORS OPTION IF NO THRUST PULSE MODULATION
spin up z-z	0.0 rpm	225		0.0	3077.7			REMOVAL OF LAUNCH INJECTION ERRORS USED IF SPUN - PREVENT FLAT SPIN
circularize	25.0 ft/sec	314		7.6	3070.1			
ANC	0.0 ft/sec	200		0.0	3070.1			
spin down	0.0 rpm	225		0.0	3070.1		196.0	
orient	270.0 deg	140	37.5	0.3	3069.8	560.0		ORIENT FOR MAST EXTENSION
spin up x-x	9.5 rpm	225	5618.1	25.0	3044.8	284000.0		SPIN UP TO 1.5 G
out gassing	0.0 ft/sec	150		0.0	3044.8	283750.0		SPIN AND ORBIT CONTROL
spin maint.	3.0 rpm	1510		1.2	3043.6	283750.0		DUE TO DRAG AND OTHER FORCES
attitude maint.	0.0 ft/sec	150		0.0	3043.6	283750.0		FOR THERMAL AND OR POWER CONTROL
drag makeup	15.0 ft/sec	1510		0.9	3042.7	283720.0		FACTOR OF SURFACE AREA AND ALTITUDE
despin	9.5 rpm	225		24.9	3017.8	283500.0		SPIN DOWN
orient	180.0 deg	150	30.6	0.2	3017.6	560.0		NULL RATES ORIENT FOR MAST RETRACTION
spin up	0.0 rpm	225		0.0	3017.6			OPTION IF NO TPM
orbit maint.	45.0 ft/sec	225		18.7	2998.9			ALIGN ORBIT FIR REENTRY IF SPIN
ANC	0.0 ft/sec	150		0.0	2998.9			
deorbit	328.0 ft/sec	314		95.7	2903.2			
orient and hold	300.0 deg	225	38.1	0.2	2903.0	520.0		SET UP FOR ATMOSPHERIC ENTRY
EMPTY MASS					2903.0			
174.6								

ASSUMPTIONS:	THRUST lbs	ISP '@600 PSI	TOTAL #	#USED main	#USED OTHER
ACS ENGINES	0.5	225	12.0	4.0	8.0
MAIN ENGINES	100.0	314	6.0	6.0	

Table 7-8. Gaseous Oxygen/Hydrogen Propellant Budget

MANEUVER	MANEUVER MAGNITUDE (ft/sec,rpm, degrees)	ISP (sec)	TIME (sec)	FUEL USED (lbs)	VEHICLE MASS (lbs)	INERTIA Z-Z (slug ft2)	INERTIA X-X (slug ft2)	COMMENTS
Separated mass				376.0	3826.7			
orient	90.0 deg	60	21.7	0.4	3826.3	560.0	196.0	NULL LAUNCH VEHICLE TIP OFF ERRORS OPTION IF NO THRUST PULSE MODULATION
spin up z-z	0.0 rpm	300		0.0	3826.3			REMOVAL OF LAUNCH INJECTION ERRORS
circularize	25.0 ft/sec	420		7.1	3819.2			USED IF SPUN - PREVENT FLAT SPIN
ANC	0.0 ft/sec	300		0.0	3819.2		196.0	
spin down	0.0 rpm	300		0.0	3819.2			
orient	270.0 deg	60	37.5	0.6	3818.6	560.0		ORIENT FOR MAST EXTENSION
spin up x-x	9.5 rpm	300	5618.1	18.7	3799.9	284000.0		SPIN UP TO 1.5 G
out gassing	0.0 ft/sec	60		0.0	3799.9	283750.0		SPIN AND ORBIT CONTROL
spin maint.	3.0 rpm	300		5.9	3793.9	283750.0		DUE TO DRAG AND OTHER FORCES
attitude maint.	0.0 ft/sec	300		0.0	3793.9	283750.0		FOR THERMAL AND OR POWER CONTROL
drag makeup	15.0 ft/sec	300		5.9	3788.1	283720.0		FACTOR OF SURFACE AREA AND ALTITUDE
despin	9.5 rpm	300		18.7	3769.4	283500.0		SPIN DOWN
orient	180.0 deg	60	30.6	0.5	3768.9	560.0		NULL RATES ORIENT FOR MAST RETRACTION
spin up	0.0 rpm	300		0.0	3768.9			OPTION IF NO TPM
orbit maint.	45.0 ft/sec	420		12.5	3756.3			ALIGN ORBIT FIR REENTRY
ANC	0.0 ft/sec	60		0.0	3756.3			IF SPIN
deorbit	1148.0 ft/sec	420		305.7	3450.6			
orient and hold	300.0 deg	60	38.1	0.6	3450.0	520.0		SET UP FOR ATMOSPHERIC ENTRY
EMPTY MASS					3450.0			
376.0								

ASSUMPTIONS:	THRUST lbs	ISP @300 PSI	TOTAL #	# USED		BLOWDOWN PSI
				main	OTHER	
ACS ENGINES	1	60	8	4	4	
ACS ENGINES	0.1	300	4.0	4.0		
MAIN ENGINES	25.0	420	6.0	6.0		

Table 7-2 shows data similar to Table 7-1 only for a monopropellant system pressure regulated at a constant 235 psia for the entire mission. Table 7-3 gives the budget for a bipropellant blowdown system. In this type of system, engine performance drops at the end of the mission due to the lower inlet pressures. This lower engine performance evidences itself in the propulsion budgets as lower average specific impulse for a blowdown system (Table 7-1) vs. a pressure regulated system (Table 7-2). The deorbit velocity for this case is 100 m/sec or 328 ft/sec, which is representative of a DRM-1 reentry. Table 7-4 gives the budget for bipropellant system pressure regulated with a 350 m/sec or 1148 ft/sec deorbit burn. Again this calculation is representative for DRM-3. Table 7-5 gives the budget for dual mode blowdown system with a 100 m/sec or 328 ft/sec deorbit burn. Table 7-6 gives the budget for a dual mode system pressure regulated with a 350 m/sec or 1148 ft/sec deorbit burn. Table 7-7 gives the budget for an advanced design dual mode blowdown system assuming a 100 m/sec or 328 ft/sec deorbit burn. This system uses 600 psi engine inlet pressures to achieve smaller and lighter componentry. Only a pressure regulated system was investigated for this option. Table 7-8 gives the budget for GOX/GH pressure regulated system assuming a 350 m/sec or 1148 ft/sec deorbit burn. This system used the smallest propellant load for all DRMs. ACS engines were assumed to consist of 1 lbf cold gas engines and 0.1 lbf hydrogen resistojets for low thrust maneuvers (spin up and spin down).

7.1.2 Propellant Tank Sizing

Initially only existing tanks made of titanium were used in system design and weight calculations. The tanks chosen from this somewhat limited list, however, turned out to be much larger than required for RRS missions. This resulted in a larger volume and weight than would be achieved with a more optimally sized system. Therefore, a second design iteration was performed assuming custom designed carbon wrapped aluminum tanks for the He pressurization tanks, and optimally sized main propellant tanks. The weights for this type of configuration were estimated based on existing tank information and scaling up or down as required to match mission requirements. Further discussions on this topic is provided in subsequent sections.

7.2 Propellant Management Devices

A number of different propellant management devices (PMDs) were studied for the various propulsion systems but the two prime types considered were bladder and surface tension devices. Bladders are thoroughly flight-proven and are relatively inexpensive to use. Bladder tanks are also insensitive to the direction of acceleration. They have a high expulsion efficiency, resulting in a low propellant residual, and are easy to test. The negative for bladders, however, is that bladders have a higher weight than other PMDs and are incompatible with many propellants.

Surface tension devices have been used extensively in long-life satellites. They have a low weight and are compatible with all propellants. However, surface tension devices have a higher propellant residual, due to their lower expulsion efficiency, when compared to bladders. They are also expensive, difficult to test, and are sensitive to the direction of vehicle acceleration.

A third option considered for propellant expulsion was the use of an auxiliary propulsion system to produce an acceleration on the vehicle that will orient the propellant over the tank outlet. After the propellant has settled, the engine being supplied must maintain the same vehicle orientation. There is no tank volume penalty, and terminal draining of the tank determines the propellant residuals. This method is an excellent option for propulsion systems such as the dual-mode bipropellant, which already has a monopropellant attitude control system (ACS) system that can easily be used to settle the oxidizer required by the main engines. If the propulsion system is not originally equipped with this expulsion capability, the addition of a separate ACS system to perform this function is usually excessively complex.

A final option considered for propellant expulsion was the use of rolling diaphragm tanks. These incorporate a thin aluminum or stainless steel diaphragm that expels the propellant. The advantages of this type of design are it can be used with any type of propellant. The tanks are not cost effective for the RRV however, as they must be removed from the vehicle and a new diaphragm installed after each flight. In addition, the tanks do not adapt to less than a 95% fraction fill as the diaphragms are susceptible to breakage during launch vibrational loads if not filled.

7.3 Residuals

Propellant residuals are a function of the type of propellant, type of PMD used, temperature extremes during operation of the system, expulsion efficiency of the propellant tanks and total system line lengths. Bipropellant systems typically have a much higher residual than monopropellant systems for a number of reasons:

- The vapor pressure of the nitrogen tetroxide (NTO) is roughly 14.7 psi at 70° degrees F. Temperature shifts from the the loading temperature causes the total pressure in the oxidizer tank to rise or fall. This causes a fuel rich or fuel lean burn condition. For the RRV, the main burn consumes ~85% of the total mission propellant. Therefore the temperature of the propellant at the end of the mission is critical for residuals. This effect is exacerbated in a blowdown system as the vapor pressure of the propellant is a higher percentage of the total pressure.
- The high vapor pressure and dense vapor means a high amount of propellant will be in vapor phase in the tank.
- Twice the number of lines filled with propellant.

These factors must be taken into account when figuring the performance of a bipropellant system. The residuals were assumed to be 20 lbs for the bipropellant system studied in this analysis. These numbers assumed a 70° F loading temperature and an end of mission temperature of 95°.

The monopropellant system investigated incorporated bladders for propellant management. The bladders isolate the pressurant and the propellant minimizing any vapor residual. Therefore the residuals were assumed to be 2 lbs for the monopropellant system.

7.4 Number of Engines and Layout

All RRS propulsion systems evaluated were designed assuming 12 ACS engines in redundant banks of 6 (2 pairs of 3 on opposite sides of the vehicle). The design of the main system had 6 engines in 2 banks of 3 each. This provided for pairs, or couples, of engines for performing all pitch roll and yaw maneuvers. All "banks" of engines were isolateable via bistable latching valves. This provided for an engine-out capability with no loss in vehicle performance; however, cross coupling would slightly increase propellant consumption for attitude control. The implementation of the redundant set of engines could be either manual or autonomous depending on the maneuver. The critical deorbit maneuver requires autonomous engine-out logic. A worst case engine failure would be a valve stuck in the closed position. This effectively prevents this engine from further operation. Open valve failure is handled by series redundant thruster valves. The attitude control system would sense this by the vehicle attitude not responding to a command thruster pulse. Depending on the location of the failed engine in respect to the vehicle center of gravity, the deorbit burn would be completed with 3 to 5 of the remaining engines with minimal loss in burn accuracy. The main maneuver engines were assumed to provide 80 to 110 lbs of thrust depending on the system design. The weights for these elements, discussed below, were taken from existing flight proven hardware.

8.0 PROPULSION SYSTEM DESIGN OPTIONS

The following sections describe point designs for various RRS propulsion systems which are analyzed in more detail in Section 9.0. Propulsion system features are discussed, along with schematics for each option, to determine the number of valves, filters, regulators, etc., required. The weights of these components were taken from existing flight proven designs used on current commercial satellite programs.

8.1 Monopropellant System

A hydrazine (N_2H_4) monopropellant system was the simplest system considered in the trade analysis. The propellant tanks were assumed to be made of titanium and use bladders as the PMD because of their high expulsion efficiency and their proven effectiveness in zero-g applications. The large propellant load for this system results in large tank volumes and has the highest overall propulsion system weight of all those considered, for both the blowdown and pressurized systems. The minimum operating temperature of $40^\circ F$ for hydrazine engines may require the use of heaters to keep the propellant above this, leading to an increase in the overall power requirement. The hydrazine thrusters are capable of a large blowdown ratio. This allows for smaller (relative to biprop systems) tankage with a lower starting ullage volume for blowdown systems. The blowdown systems were designed with an initial tank pressure of 350 psia. The maximum loading gives a final tank pressure of approximately 70 psia. The regulated or pressurized system has the regulator set at 235 psia. A schematic of the monopropellant system is shown in Figure 8-1.

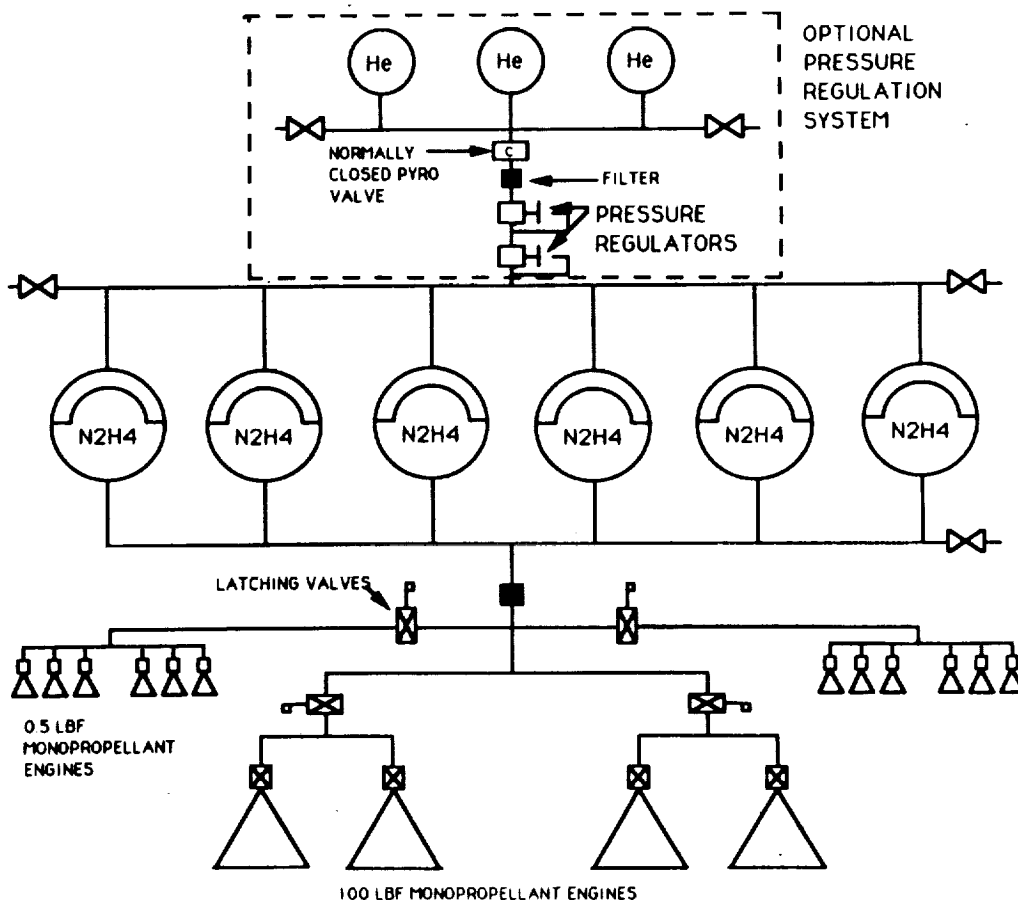

Figure 8-1. Monopropellant Propulsion System Schematic

8.2 Bipropellant System

The bipropellant system analyzed incorporates N_2O_4/MMH for both the deorbit and ACS engines. Titanium propellant tanks were assumed using surface tension devices since N_2O_4 is incompatible with bladders. The minimum propellant operating temperature for bipropellant engines is $20^\circ F$. Because of this less stringent condition, the heating requirements for the bipropellant system may be lower than those for the monopropellant system. The bipropellant system has a starting pressure of 350 psia. The blowdown ratio is not as large as the monopropellant system because the bipropellant engines do not perform well at pressures lower than approximately 100 psia. The final end of mission pressure for a maximum load case (e.g., DRM-3) is 100 psia. This gives a fairly conservative 2.5:1 blowdown ratio. The pressurized system had a regulator set point of 235 psia. A schematic of the bipropellant system is shown in Figure 8-2.

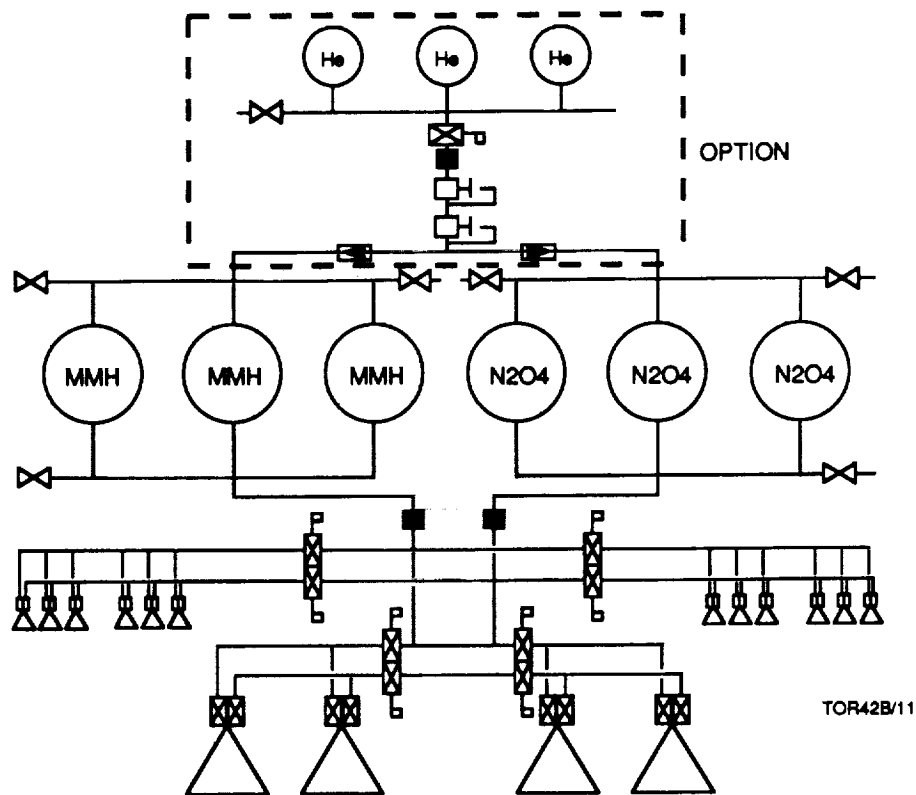

Figure 8-2. Bipropellant Propulsion System Schematic

8.3 Dual-Mode Bipropellant System

The dual-mode bipropellant system assumed N_2H_4 alone was used for the ACS system and N_2O_4/N_2H_4 for the divert engines. Such a system is less complex than a true bipropellant system. The hydrazine tanks are equipped with bladders, and the ACS engines will be used to settle the N_2O_4 before divert engine firing. For this reason, no PMDs are required in the N_2O_4 tanks which reduces system weight and cost. As with the monopropellant system, heaters (and their corresponding power requirement increase) may be required to keep the hydrazine above its minimum operating temperature. The dual mode system is limited in the blow down range by the main engine minimum inlet pressure of 125 psia. The tanks are initially loaded to 350 psia, identical to the aforementioned systems. The regulated pressure set point for this system is 235 psia. A schematic of the dual mode system is shown in Figure 8-3.

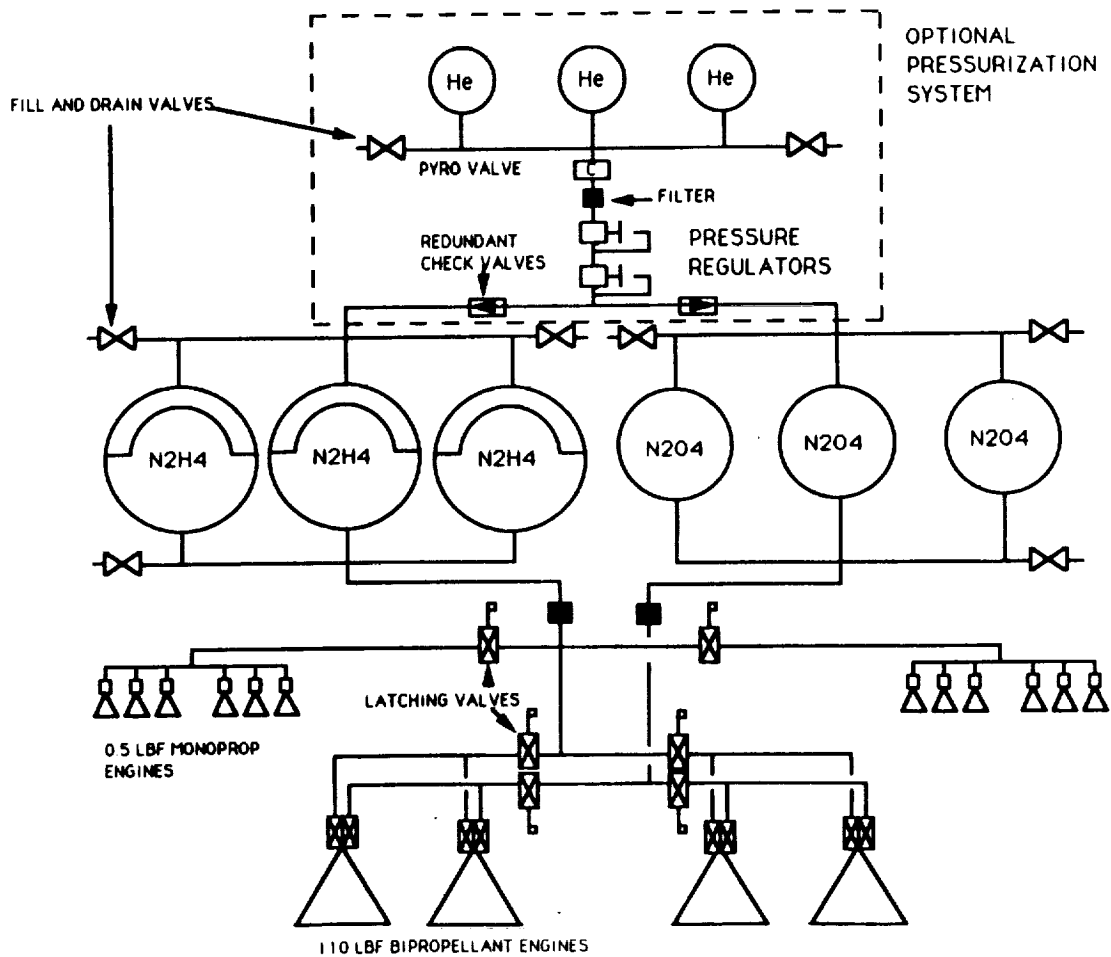

Figure 8-3. Dual Mode Propulsion System Schematic

8.4 LO₂/LH₂

A propulsion system employing LO₂/LH₂ as its propellant was considered due to the very high performance achievable with such a system (Isp=420 sec). This performance was based on the engine developed for the space station program. The engine burns gaseous hydrogen and oxygen. Propellant storage could be accomplished either with high pressure tankage or cryogenic storage to reduce the volume and weight requirements. High pressure gas storage was rejected for this system due to the excessive volume and weight. As an example, 350 lbs of gaseous propellant would require almost 1000 lbs of carbon filament tankage for propellant storage. Cryogenic storage would cut the tank weight in half. However, the use of cryogenics greatly increases the complexity and cost of the system. Cryogenic propellants also introduce the major problem of propellant boiloff. To combat this problem, either elaborate insulation is needed or an additional complex cryo-cooling system is required. These additional complexities are definitely not desirable. Ground-hold ice formation can cause degradation of the insulation. Boiloff requires an adequate venting system, including valves that are extremely sensitive to moisture. Materials and components selected for a propulsion system using cryogenics must be chosen for their performance at very low temperatures. In addition to the complexity of cryogenics, the extremely low density of the LH₂ results in very large propellant tanks. For all of these reasons, an LO₂/LH₂ system was not considered a serious option for the RRS propulsion system.

8.5 Advanced Technology Propulsion System

For comparison purposes, an N₂O₄/N₂H₄ bipropellant system was investigated which uses all advanced technology components. The propellant tanks were assumed to be made of aluminum liners with carbon fiber overwrap, resulting in a 55% reduction in tank weight. The engines, valves, filters, and regulators were assumed to be advanced technology designs being developed for various SDI applications. The advanced technology system uses diaphragm tanks with stainless steel diaphragms for propellant expulsion. This lowers the residuals that would normally be associated with a bipropellant system. The overall system weight is at least 50% lower than the conventional propulsion system weights described above.

The dry weights of this system, along with each of the other systems discussed above, are shown in Table 8-1.

Table 8-1. Propulsion System Dry Weights in Lbs. (Includes Residuals)

Component	Mono Propellant N ₂ H ₄		Dual Mode N ₂ H ₄ + N ₂ O ₄		Bipropellant MMH + N ₂ H ₄		GOX/GH ₂		Advanced N ₂ H ₄ + N ₂ O ₄	
	#	Mass (lbs)	#	Mass (lbs)	#	Mass (lbs)	#	Mass (lbs)	#	Mass (lbs)
Fuel Tanks Oxidizer Tanks	6	16.5	3	16.5	3	10	3	60	3	6
Pressure Regulated Helium Tanks	3	8	3	7.75	3	10	3	125	3	6
Regulator Valves/Filters Smaller Prop Tanks	2	3.9	2	3.9	2	3.9	2		2	1
ACS Thrusters	12	0.68	12	0.68	12	1.4	12		12	0.3
Deorbit Thrusters	6	3.78	6	9	6	8.5	6		4	1.7
Valves/Filters										
Tubing-Misc.										
Residual-Unusable										
Total - Blowdown Systems		144.84		177		170		555		53
Total - Pressur- ized Systems				173		166		0		
Volume (Cu Ft)		13		9.6		9.7		29.3+		
Volume (Cu Ft)		10.7		6.9		6.9				6.3

9.0 TRADE STUDY RESULTS

The selection of an optimal propulsion system for the RRS began with the elimination of design choices that would require significant development, have major impacts on the vehicle design or would require major ground support systems. The next step was to review the dry and loaded weights for the remaining propulsion systems. The propellant usage for a range of deorbit and on-orbit maneuvers (assuming a 1.5 g artificial gravity 60 day mission) for each system defined in Section 8.0 is summarized in Table 9-1. The total mass for a given mission would be the sum of the dry mass described earlier and the propellant loads shown in this table. These data, balanced against the performance requirements necessary to perform the RRS mission, were used to arrive at the selected system.

Table 9-1. Propellant Usage by System for Selected Deorbit Delta-Vs

D R M	Delta Deorbit Velocity (ft/sec)	Monopropellant		Bipropellant					
		Pressure Regulated (Press)	Blowdown (BD)	CH ₃ N ₂ H ₃ +N ₂ O ₄		N ₂ H ₄ +N ₂ O ₄		Advanced	GOX/GO ₂
				Press	BD	Press	BD	Press	Press
1	328 (100 m/s)	236	241	176	178	201	202	196	154
	574 (175 m/s)	340	348	255	258	279	281	270	219
	820 (250 m/s)	447	458	355	346	359	363	347	285
3	1148 (350 m/s)	596	624	454	467	468	477	452	376

The LO₂/LH₂ system and the advanced bipropellant system described in Section 8.0 would require extensive thruster and tank qualification test programs before implementation. Thus, they were ruled out on the basis of cost (i.e., expensive new development programs). Table 8-1 shows that the dry mass difference between the remaining storable propellant systems is less than 35 lbs. The difference in propellant consumption is directly proportional to the deorbit maneuver velocity requirement. For the worst case (350 m/sec), the mass difference between the worst and best system (monoprop blowdown and bipropellant pressure regulated respectively) was 170 lbs. This difference decreased to 55 lbs with a 100 m/sec deorbit maneuver.

The bipropellant system has space heritage; however, no thruster of less than 2.2 lbf is currently space qualified. The Astromast spin up requirement that the thrusters deliver less than 1.0 lbf total thrust implies that the maximum spin up engine be 0.5 lbf thrust. This ruled out the bipropellant system as an option. This effectively left the dual mode and monopropellant systems as options.

Pressure regulated systems save weight by delivering increased thruster performance over the course of the mission and lowering the propellant tank volume. Performance is increased by having the thrusters operate at a constant pressure. This is in lieu of the blowdown operation where the thrusters operate at high pressures at the beginning of the mission and low pressures at the mission end. A lower propellant tank mass results from a minimal ullage volume requirement (typically 5% for a fully loaded system) for the pressurize regulated system (blowdown system ullage typically 20-35%). This savings is offset, however, by helium tank and regulator masses. The regulated systems offer larger savings as total propellant load increases. For systems in the RRS class, a savings of only 15 lbs is achievable. These savings are at the cost of additional complexity and cost of the regulated system. Thus the minimal weight savings and higher cost and complexity eliminated regulated systems as an option for the RRS.

10.0 CONCLUSIONS / RECOMMENDATIONS

A liquid monopropellant blowdown propulsion system was found to be superior in meeting the requirements of the RRS and is recommended as the baseline system. This system was chosen over all others considered for the following reasons:

- 1) The monopropellant system is the simplest of all investigated with the fewest number of components. The components required for such a system are all fully space qualified and are in production.
- 2) The monopropellant system was the most cost effective since it is relatively inexpensive compared to the other systems. In addition, low unit cost implies that repair and/or replacement costs will be low as well.
- 3) No new hardware qualification is required for a monopropellant system. All of the other systems considered, except for the dual mode, required major component qualifications.
- 4) Although the two bipropellant system offered some weight savings capability for missions requiring large deorbit velocities, better spin balance (equal mass on fore and aft sections of the deployed RRS) could be obtained with the monopropellant system. The mass of propellant is consumed before reentry and is not detrimental to the reentry stability. Thus the heavier propulsion system mass of the monopropellant system was deemed an advantage for the SAIC RRS concept.

- 5) Similar to reason number 4, the advantage of lower mass system is only applicable if the total vehicle design can be reduced to allow a cheaper launch vehicle to be used. At the time of this trade study, the overall RRS weight budget and launch vehicle selection was not being driven by the propulsion system selection. Thus, the added cost and complexity of more advance systems do not warrant application.
- 6) The final reason a monopropellant system is recommended for the RRS is that storable bipropellant main engines and bipropellant ACS engines are not as readily adaptable to blowdown operation. The engines would run excessively hot at the beginning of the mission (given a 350 psia inlet pressures) and are more susceptible to poor operation at the lower inlet pressures as the mission progresses. Poor operation is defined as chugging or induced off-mixture ratio combustion.

The recommended system design incorporates series redundant single coil valves for both the attitude control and deorbit engines. This provides for engine-out capability. Dual-coil-dual seat valves would prevent loss of an engine due to coil failure, but they were not felt to be necessary considering the short mission duration, increased complexity, weight, and power consumption of dual-coil valves. The peak power consumption for the propulsion system is 252 W. This equates to all six deorbit engines firing at once, with each engine requiring 1.5 Amps for both valves. Other power consumption items for the propulsion system include: line, valve, and thruster heaters as well as pressure and temperature sensors. Heaters for the propulsion tanks are not required based on thermal analysis to date, while valve and thruster heaters would be used only before firings and are included in the power budget. There are two pressure transducers for the system and sufficient temperature sensors to determine system performance and control heater functions, if required.