

510-91

140728

p. 25

Mining Nonterrestrial Resources: Information Needs and Research Topics

Jaak J. K. Daemen*

The following research topics have been generated by my reading of the draft reports "Exploring, Evaluating, and Mining Nonterrestrial Resources," "To Build a Mine," "Asteroid Mining," and especially "A Baseline Lunar Mine." For a mining engineer like myself who is totally unfamiliar with nonterrestrial operations, this is a fascinating and stimulating opportunity to take an entirely different viewpoint on operations that usually seem humdrum and routine. Being forced to reevaluate the basics might be as productive for our mining on Earth as it is necessary for nonterrestrial operations.

This paper presents an outline of topics that we need to understand better in order to apply mining technology to a nonterrestrial environment. The proposed list is not intended to be complete. It aims to identify representative topics that suggest productive research. Such research will reduce the uncertainties associated with extrapolating from conventional earthbound practice to nonterrestrial applications. No attempt is made to rank the topics. One objective is to propose projects that should put future discussions of nonterrestrial mining on a firmer, less speculative basis.

I offer no details about the actual pursuit of the various research topics. Each one could be approached by a fairly standard method; e.g., starting with a comprehensive literature survey, identifying relevant technical specialties and authorities in the field, detailing research needs, initiating specific projects, reviewing progress, making theoretical analyses, eventually culminating in system designs and experimental trials. It would seem highly desirable to have close interaction between mining experts and space experts, so that no easily avoidable oversights are made in these studies.

I have not used a formal analysis of information needs to select research topics; I make my suggestions purely on the basis of professional judgment. An explicit investigation of information needs and of their relative significance within an overall nonterrestrial mining program would be a desirable step in initiating research. An alternative method of initiating and scoping research, which might take less time, is to present issues to a group that includes both mine equipment designers and operators and space equipment designers and operators.

*Department of Mining and Geological Engineering, University of Arizona, Tucson.

The topics identified are inconsistent in terms of their depth and scope. Some have been included to illustrate broad areas that need review; others, to illustrate much more narrowly focused items. Although this inconsistent scale results in some overlap among topics, I think it is appropriate because it points out that there are uncertainties in need of resolution at many different levels of technical detail.

Williamson (1985) has suggested that lunar-based mining may become operational by about 2020, and Glaser (1983) has suggested that nonterrestrial resources may be used even earlier. Profound changes may be required in equipment and in modes of operation to fulfill these suggestions. Now is the time to at least start evaluating whether or not such changes will be needed.

This list of proposed research topics is assembled and discussed from a mining engineering point of view. It is aimed at identifying and clarifying some typical information needs and uncertainties that will require resolution in order to implement

mining practices on the Moon or in other space environments. We must recognize that much of the proposed research could make a substantial contribution to future development of mining on Earth. This point deserves emphasis for two reasons: First, technology transfer to terrestrial applications is an explicit NASA mission (stated, for instance, by Firschein et al. 1986, appendix), mandated by Congress. And, second, if the mining industry clearly recognizes the potential benefits for its own future, it is far more likely to cooperate in productive research. The potential for such mutual benefits needs to be expressed directly and specifically, because such potential may not be self-evident to the industry. In fact, a more likely reaction is serious doubt as to whether such "exotic and far out" investigations have any bearing at all on conventional commercial practice. At some point in the future, it may be well to revisit the topic of nonterrestrial mining from a terrestrial technology transfer perspective, focusing on the benefits such a program might deliver to the state of the art of mining technology.

1. The influence of gravity on mechanical excavation technology and on the performance of associated equipment

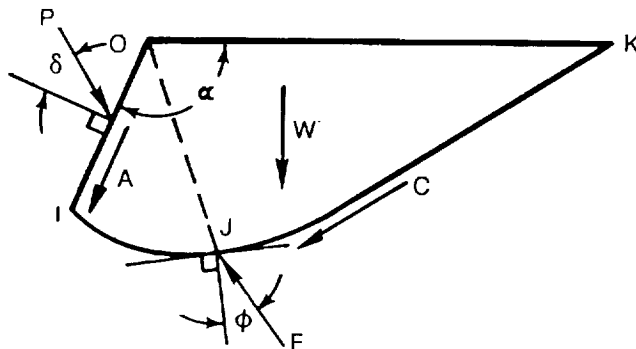

Force System Used for Plastic Analysis of Soil Gathering by Bulldozer

The frictional (P) and adhesive (A) resisting forces, as well as the weight (W), depend on gravity. It is probable that the resisting forces are also influenced by operation in a vacuum.

From Hettiaratchi and Reece 1974, as modified by Karafiath and Nowatzki 1978, p. 247.

Key:

- A = the adhesive component of the resisting force; it acts along the surface of the plane OI where the soil ruptures
- C = cohesive strength of the soil
- P = the frictional component of the resisting force; it acts at angle δ
- δ = soil interface friction angle
- F = the resultant of the normal and frictional forces
- ϕ = angle of internal friction
- W = weight of the soil being dozed
- OIJK = body of soil being pushed up and out

Gravity force components enter into the mechanics of most excavation and loading methods. The significance of gravity is likely to differ with the excavation method, particularly with the mode of operation and with the configuration of equipment. Because differences in gravity will be significant between nonterrestrial and conventional earthbound excavation and loading, it would be desirable to evaluate the sensitivity of excavation and loading technologies to gravity. This comparative assessment should include such major performance aspects as power requirements, capacity,

productivity, and breakout power. Classifying these aspects with respect to their sensitivity to gravity will provide insight into the relative performance of various systems under significantly different gravitational conditions. Such a classification will help identify preferred excavation methodologies for nonterrestrial applications. This assessment of the impact of gravity on excavation performance will also assist in identifying needed equipment design changes and in establishing correction factors for estimating production figures in a low-gravity environment.

2. The status of remotely controlled and automated mining

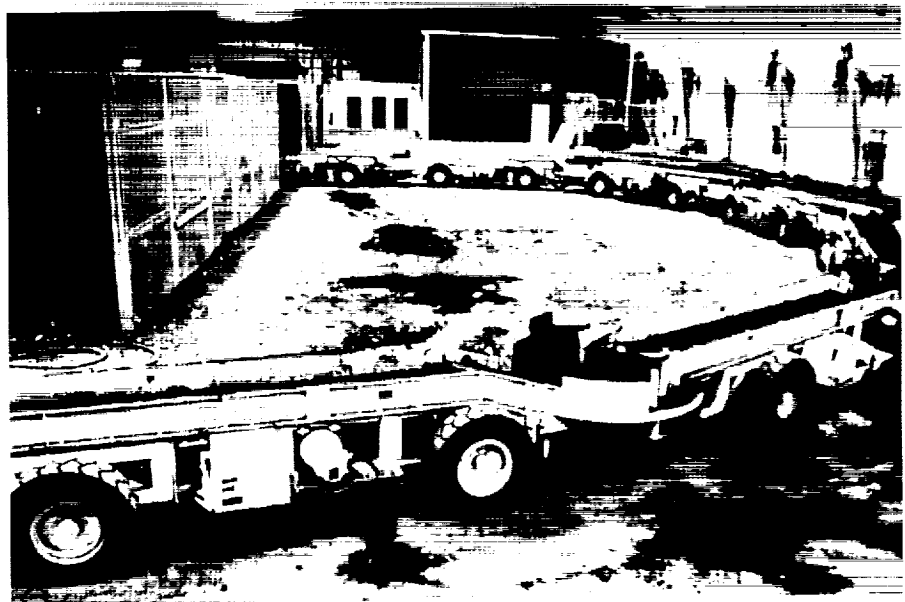
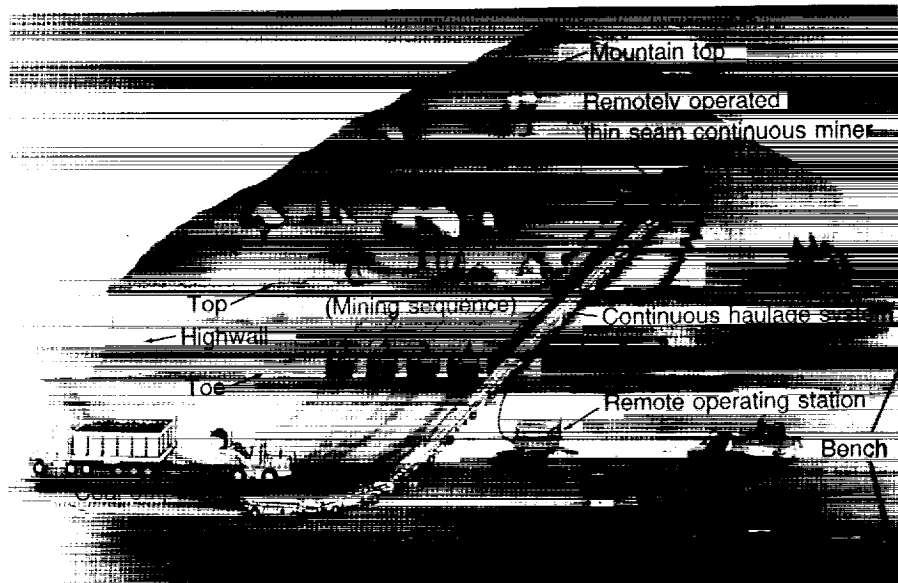

a. *Computer-Based Remotely Controlled Highwall Mining System (HMS)*

b. *HMS Continuous Haulage Subsystem During Surface Evaluation*

From Kwitowski et al. 1988.

The degree to which nonterrestrial mining operations will be run automatically or under remote control (i.e., the extent to which people will need to be present at or near the mining operation) will have a major economic and logistical impact on the type of operation that can be implemented. Remote control over very short distances (that is, with an operator not more than tens of meters from the equipment) has become readily available for mine face operations (continuous mining of coal; longwall mining; drilling; train, truck, and loader movements; etc.). There has been some success in running underground operations from a great distance [see, for example, the article in *Coal Age*, vol. 92 (1987), no. 8, p. 61], admittedly on an experimental basis.

Even a cursory review of recent mining literature reveals the industry's considerable interest in the subjects of remotely controlled and automated mining (e.g., Atkinson, Waller, and Denby 1987; Hopkins 1987; Scales 1987; Stricklin 1987). It appears virtually certain that considerable progress will be made in these areas in the near future. However, we must acknowledge that highly optimistic announcements about forthcoming mine automation have been made repeatedly, and for at least two decades.

Given the potential importance of automated and remotely controlled mining for nonterrestrial operations, I think it appropriate to recommend an intensive effort to evaluate the current state of the art of such technologies, with emphasis on operations in hostile environments. Mining experience has shown that the environment poses severe problems, especially with regard to transducer performance (see, for example, Atkinson, Waller, and Denby 1987 and Stricklin 1987).

I propose that an interactive investigation of such problems with authorities in other fields would be beneficial in identifying possible solutions. Specifically relevant may be remotely controlled equipment for handling nuclear materials, especially for reactor cleanup operations (Kring, Herndon, and Meacham 1987), as well as sensors, transducers, and transmitters developed for the space program (Stuart 1983; Wagner-Bartak, Matthews, and Hill 1983; Firschein et al. 1986). I think it likely that an integration of already existing knowledge may result in readily available improvements to the control systems typically used in mining.

Similarly, it may well be that cost considerations have so severely affected mining systems design that their reliability is unacceptable for space operations. Economic

tradeoffs in nonterrestrial mining are almost certain to be different from those in earthbound mining. Hence, it may well be that the reservations and concerns about control engineering which have been generated by mining experience may not be appropriate to space designs. An obvious first step in resolving these uncertainties is simply to assemble a group of experts with relevant backgrounds and have them discuss the problems.

3. Environmental effects on lunar surface mining

Environmental factors such as temperature, air pressure, dust, and visibility have a significant impact on mining operations and equipment. Of most immediate concern is the difference in temperature and atmosphere for nonterrestrial mining as compared to conventional earthbound mining. This difference has significant implications. The cold of the 2-week night on the atmosphereless Moon virtually eliminates the possibility of nighttime operations with conventional equipment because of the problem of material brittleness. And the heat of the 2-week lunar day, unshielded by an atmosphere, will impose demanding cooling requirements. A team of space equipment designers and mine equipment designers should be able to identify mechanical and electrical problems and potential solutions, as well as the redesign

needs implied by these solutions. Daytime lunar surface operations, particularly rock loading, could be severely affected by perception problems induced by the bright sunlight and constantly changing shadows (discussed by Firschein et al. 1986, p. 112).

4. The applicability of conventional mining methods and equipment to lunar mining

When one considers the applicability of Earth technology to lunar mining, one can focus rapidly on a likely lunar project and retrofit an available mining method to meet the characteristics of this particular project. However, I propose that program benefits might derive from a comprehensive analysis, at a preliminary scoping level, of the applicability of conventional earthbound mining methods and technology to lunar operations. Such an analysis could proceed from a comprehensive matrix, listing mining methods along one axis and lunar features (such as logistics, gravity, vacuum, temperature, perception problems) likely to affect mining along the other axis.

To each mining method, one can assign weights for the various differences between terrestrial and lunar operations. Initially the weighting could be done on the basis of expert judgment. But as soon as possible the weighting

should be based on a numerical analysis. For simple mining methods, the weights could be based on the mechanics of the system. For complex methods, the weighting may require a comprehensive numerical simulation of an entire sequence of operations. This technique would allow a formal assignment of level of difficulty likely to be encountered in applying the terrestrial technology to the lunar situation.

An effort of this type should be iterative. The initial list may include technology that is entirely inappropriate or exceedingly difficult to modify or implement. In parallel with such iterations, one might also expect a progressive refinement in the information needs about the most likely operational conditions.

5. Underground construction methods for lunar application

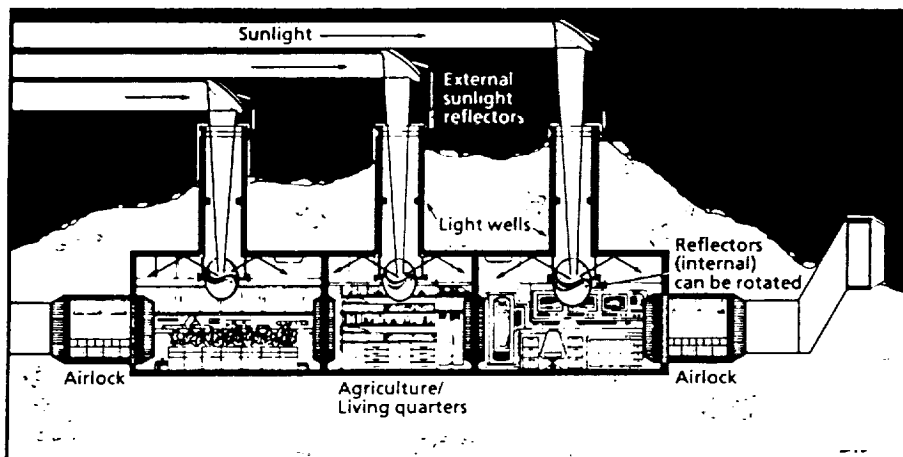

a. Underground Mining

Although the baseline lunar mine was conceived to be a strip-mining operation, there may be locations where the regolith is so thick that it could be mined by some undercutting scheme. Excavations could be driven below the material to be mined, and the material could be drawn into the excavations for milling. The light wells in this illustration could correspond to draw points for bringing material directly underground, and the agriculture/living quarters could correspond to the scene of all subsequent mining operations, which would thus be shielded from the hazards of the lunar surface environment.

As pointed out under topic 3, the environment will impose severe limitations on surface operations on the Moon. It therefore appears fully warranted to investigate the feasibility of moving mining operations underground. Lunar scientists can probably provide information on the subsurface lunar

temperatures, and this information may encourage the investigation of going underground.

Operating underground on the Moon raises a number of intriguing questions. Conventional support systems such as concrete, steel, and shotcrete are likely to have an



b. Tunneling for Lunar Habitats

Perhaps the tunneling techniques developed for mining could be used to construct lunar habitats. The two astronauts in this illustration provided by Encyclopaedia Britannica seem to be having no difficulty carrying a capacious pressurizable module for a tunnel. In gravity only 1/6 that of the Earth, the required weight-carrying strength of equipment as well as people could be reduced to 1/6 that required on Earth.

even less favorable weight-to-performance ratio than on Earth. Hence, the economics of their application need to be investigated in detail. As I briefly outline under topic 7, the preclusion of conventional support systems would not necessarily exclude underground construction in weak or disintegrated ground, but it would put a premium on developing reinforcement methods, integrated with the construction cycle, which minimize weight requirements. Given that the most frequently encountered and most severe problems for earthbound underground construction and mining arise from unexpected conditions (that is, sudden changes in ground quality), it is virtually certain that underground lunar construction should be preceded by markedly better site investigation and characterization than is the norm on Earth.

Underground construction on the Moon should have some significant advantages when compared to earthbound practice. Most underground construction problems are associated with water, because of excessive pressure, excessive flow, or both. Indeed, a standard if somewhat overstated saying among engineers holds that "a dry tunnel is an easy tunnel." The absence of water will facilitate underground construction on the Moon. Moreover, the certainty of not

encountering water will eliminate the need to plan for the contingency.

The increased friction (more intimate physico-chemical bonding) in vacuum (Karafiath and Nowatzki 1978, p. 130) should assist in stabilizing underground excavations. It may also make excavation somewhat more difficult, but excavation per se usually is a relatively minor cost factor in underground mining. The low gravity will increase the weight-carrying capacity of equipment and reduce the energy requirements of muck haulage and particularly hoisting. Light levels, and hence visibility, may be easier to control underground than on the lunar surface.

Underground construction on the Moon will differ from underground construction on Earth in a number of important aspects. Its potential advantages over surface construction appear to warrant a comprehensive assessment of its merits. Such an assessment should address all aspects that affect life-cycle costing.

6. Rock drilling on the Moon

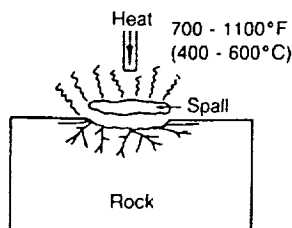

a. Spalling

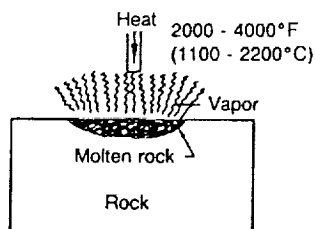

b. Melting and Vaporization

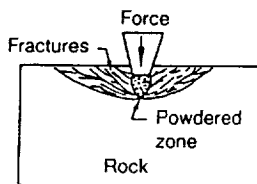

c. Mechanical Stress

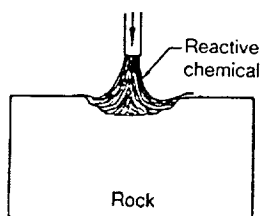

d. Chemical Reaction

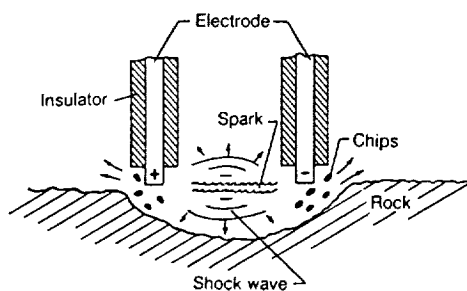

e. Spark Cratering

Methods for Disintegrating Rock

- a. **Spalling:** Inducing high thermal stresses by rapid application of intense heat.
- b. **Melting:** Liquefying rock by raising its temperature.
- c. **Mechanical Stress:** Inducing stresses exceeding strength by applying mechanical forces to the rock.
- d. **Chemical Reaction:** Dissolving rock bonds.
- e. **Spark Cratering:** In a variant of c, discharging sparks between electrodes to generate pressure pulses which in turn chip the rock.

From Maurer 1980, pp. 1 and 509.

Different types of rock drilling are likely to be required on the Moon. Certainly core drilling will be desirable, if not essential, for collecting samples for rock characterization tests. But alternative, much less expensive hole-drilling techniques (in which the material from the hole is not kept intact) may be considered for such purposes as anchoring structures, explosive fragmentation, or even sample collection.

All conventional rock drilling methods, including diamond coring, rotary drilling of soft rocks, and percussion drilling of hard rocks will be affected by differences between lunar and terrestrial operating conditions. Most obvious are differences in gravitational pull, atmospheric pressure, and thermal conditions.

The very low gravitational forces on the Moon are likely to require a thrust system designed to assure adequate drilling progress. This could be a passive (weighting) system or an active (jacking) system. Regardless of which approach is taken, it seems very likely that drilling equipment will require significant modifications in order to provide the necessary thrust.

The lack of atmosphere on the Moon will create complications in providing and maintaining drilling fluids. In conventional practice such fluids are needed, in considerable quantities, in order to remove cuttings from the hole and to cool the drill bit. And on the dry and highly fractured surface of the Moon, these fluids would be easily lost. Cooling of the bit, as well as of the drilling motor, may be further complicated by the thermal environment on the Moon. This will certainly be a complication during daytime operations on the surface.

In sum, fundamental aspects of rock drilling are affected significantly. This impact will be reflected in needed changes to drilling equipment and operations. A first step in the investigation will be to determine as narrowly as possible the expected conditions under which drilling will have to be performed. This determination will in turn allow an identification of the basic parameters to be used in evaluating changes in fundamental drilling mechanics and hydraulics. Finally, such changes will lead to equipment modifications, if not to totally new drilling designs.

While this discussion has centered nearly exclusively on conventional drilling technology, I should point out that extensive investigations have been made of numerous, radically different drilling technologies (e.g., Maurer 1980). A variety of reasons, including high conversion costs, institutional inertia, and the fact that most novel drilling methods require large amounts of energy, have so far prevented the widespread implementation of such alternative

drilling methods. The novel drilling and rock excavation method that has found most widespread application—water jet excavation—is inappropriate for space applications. For reasons similar to those discussed under the next topic (rock melting), tradeoffs will need to be made between energy use (high for novel technology, low for conventional drilling) and delivery weight (low for novel technology, high for conventional drilling).

7. Lunar construction by rock melting

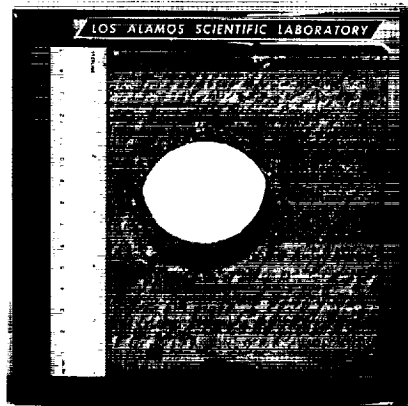
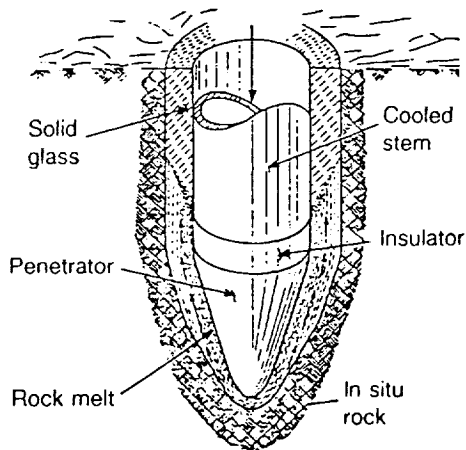

Consolidating Penetrator

The schematic diagram (Sims 1973, p. 7) shows how this novel drill bit penetrates loose soil or porous rock by melting it. Then the cooled drill stem consolidates the melted rock into a dense glass lining. The photograph (courtesy of John C. Rowley, Los Alamos National Laboratory) shows a hole melted through volcanic tuff by means of a consolidating penetrator. Note the dense (and therefore strong) hole liner.

Many aspects of mining may have to be altered profoundly for operations in an environment with low gravity, extreme temperatures, and high vacuum, at locations where direct human access and support will be exceedingly expensive. Because the differences between conventional and space operations may be drastic, it may be appropriate for us to evaluate radically different approaches.

One option that deserves attention is a rock melting system. This rock excavation method has been extensively investigated by Los Alamos National Laboratory (Neudecker, Giger, and Armstrong 1973; Sims 1973; Rowley 1974; Hanold 1977). Rock excavation by melting has been developed to an operational level for small-scale applications (drilling holes) and is proposed for large-scale applications (excavating tunnels).

For space applications, the system has the attractive feature of being

self-contained; that is, of requiring minimal deliveries. It can, for example, melt its own liner in situ (in weak ground), thus obviating the need for additional support installation. However, it may require excessively high energy. It is interesting to note that the developers of rock melting for full-size tunneling envisioned the use of nuclear power, and it has been argued that nuclear power is essential for large-scale lunar development (Ehrlicke 1983).

The rock melting approach option is included here to stress the desirability of taking a broad view to identify appropriate technologies; that is, going well outside the bounds of conventional solutions. Whether rock melting is an appropriate alternative to conventional mining remains to be seen. A scoping meeting involving Los Alamos personnel associated with rock melting would seem a desirable first step to determining whether or not further evaluation is warranted.

8. The implications of vehicle traction on the Moon for mining operations

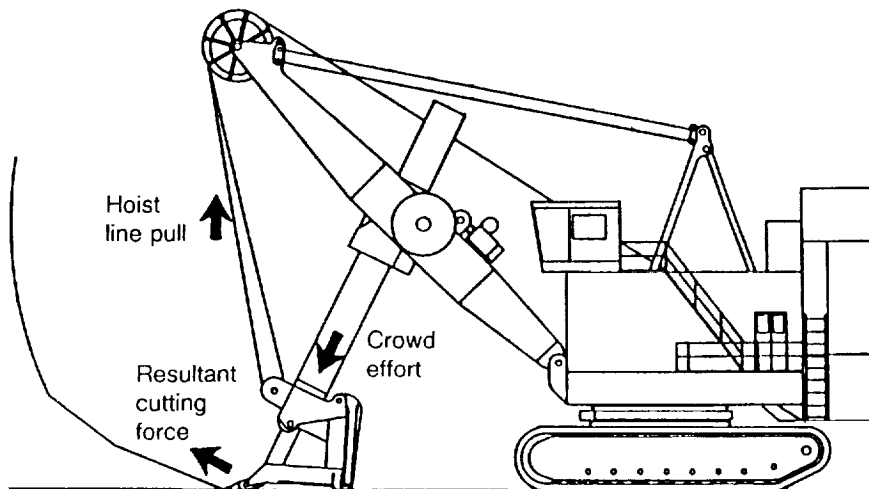

Simplified Force Diagram for a Conventional Mine Shovel

The cutting force of a shovel is a function of hoist line pull, crowd effort, and front-end geometry. A large machine weight is needed to provide horizontal resistance to slippage during digging.

Courtesy of J. D. Humphrey, Dresser Industries

Traction is an important operational aspect of most vehicles. It is particularly important for vehicles that need to exert large horizontal forces; e.g., for excavating, loading, and hauling. Many types of mining equipment are very dependent on the development of adequate traction. This equipment includes excavation equipment such as bulldozer-mounted rippers and scrapers, front-end loaders, shovels, and drills, especially those for drilling angled or horizontal holes.

Comprehensive studies have been performed of vehicle traction on the Moon (among them, Karafiath 1970a,b; Nowatzki 1972). Even though these have addressed the

operations of primarily small, lightweight roving vehicles, they provide fundamental insight into the traction of larger, heavier lunar mining vehicles. Moreover, experience with the lunar Rovers has provided an operational record by which to validate the traction models and predictions made for them.

Traction deserves attention because it is a major force needed for many mining operations. Because it is a function of gravity and of friction, the latter affected by vacuum, it will be affected by the space environment. Considerable experience is available to guide further research into this aspect of lunar mining.

9. Moon excavation technologies



Muck Pile

This is an example of a good muck pile, well-fragmented and largely remaining in one heap. Loading would be much more time consuming if the rock were widely dispersed, as it might be by conventional blasting in a low-gravity environment, without air resistance. The loading machine must have sufficient traction (created by both friction and weight) to be able to push the loading bucket into the muck pile.

Lunar mining may involve the removal of various types of ground, ranging from massive solid rock to loose, granular soils. This possibility suggests the need to investigate a range of material-removal technologies. It may be desirable, at this early investigation stage, to distinguish between the fundamental mechanics underlying the technologies and the technologies themselves. Both will be affected by operations on the Moon, but in different ways.

a. Hard rock excavation mechanics

In earthbound mining, hard rock is removed primarily by explosive excavation. Lunar blast design is likely to require significant changes from conventional blasting. An obvious consideration will be the need to control the broken rock pile. It is usually assumed that gravity plays no role in actual rock breakage by conventional blasting, but it plays a significant role in displacement of the broken rock

(and thus dominates the shape of the muck pile). Low gravity could result in extremely wide scattering of rock fragments, even more so in the absence of air resistance, and hence lead to exceedingly inefficient loading operations. An interesting challenge may be posed by the need to adjust blasting patterns from the traditional ones to those designed to minimize scatter in a low-gravity and high-vacuum environment.

It is possible that vacuum might affect blasting performance, although it may not be a significant factor in low-permeability rock, at least at greater depths. The breakage induced by blasting is usually attributed in part to seismic effects and in part to gas pressure effects. Presumably gas pressure effects could attenuate much faster in a space environment than on Earth. This could affect fragmentation and almost certainly would affect heave and throw; i.e., rock movement.

Potential impacts of low gravity on mechanical excavation have been discussed under topic 1. Drastically different excavation

technologies are summarized by Maurer (1980), and they deserve intense scrutiny for lunar applications.

b. Soft ground excavation mechanics

Mechanical excavation of loose, granular material on the lunar surface is likely to be facilitated by the lower gravity in terms of actually lifting the material, although this improvement may be partially offset by increased friction between particles. It is likely that the most significant detrimental effect will be on the forces that can be delivered by the equipment. Reduced equipment weight will reduce breakout forces and sliding stability. It is quite possible that even a simple force analysis of excavation systems will shed considerable light on lunar soil loading requirements and potential problems. Gertsch has suggested that we add mass to lunar equipment by building into it large volumes to be filled with lunar rocks. However, as he notes, the added mass would add to the problem of inertia in mobile equipment.

10. Potential asteroid fragmentation technology

Thermomechanical Boulder Breaker

A mobile thermomechanical boulder breaker could fragment rock by first weakening it by applying heat (in this concept by means of a burner) and then hitting it with a mechanical impactor.

From Thirumalai, Demou, and Fischer 1975, quoted by Maurer 1980, p. 653.

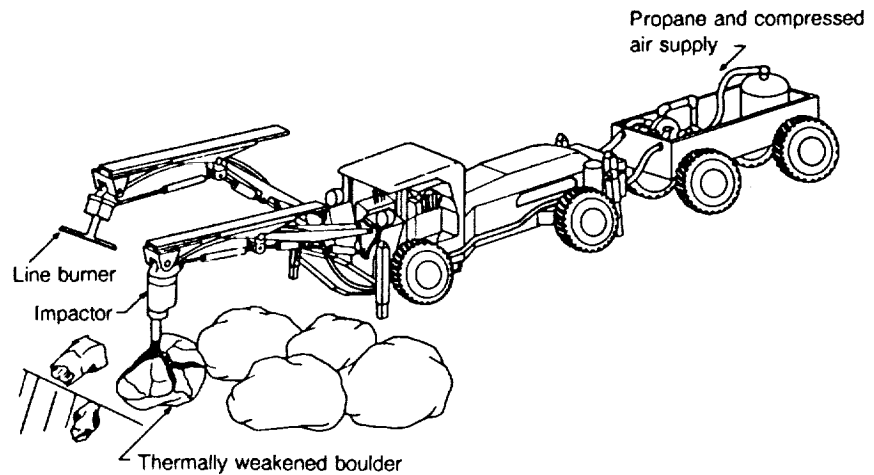

Technology for fragmenting rock particles has been researched and developed over many decades. Conventional fragmentation is primarily mechanical. Its effectiveness on a virtually gravity-free asteroid will depend in part on the degree to which the mechanical fragmentation system depends on gravity. We can conceptualize mechanical fragmentation systems that are independent of gravity; i.e., those that work by splitting or pinching. Also available are a

variety of explosive, electrical, chemical, and thermal disintegration methods. These methods will impose different logistical requirements, depending on what supplies they need and on how operations are carried out. For example, the efficiency of several fragmentation methods would increase if the fragmentation took place in drill holes. But drilling holes in asteroids will pose unusual problems (see topic 6).

It may be desirable to distinguish between two classes of fragmentation problems, those where a single fragment (or a small number of fragments) is to be removed or reduced to certain dimensions, and those where a large number of particles are to be reduced in size. The latter class of applications is discussed under topic 15, crushing and grinding. The choice of technology most readily applicable to removal or controlled-size reduction of a single large block might well benefit from an evaluation of quarrying practice for building stone. Advanced rock disintegration techniques, some of which should have direct applicability to space operations, are summarized by Maurer (1980).

11. Automation, operator proficiency, and excavation efficiency

Eliminating the need for human operators would significantly enhance the economic attractiveness of nonterrestrial mining. Few attempts have been made at developing fully automated mining excavation cycles; i.e., operations without human intervention. The economic incentives for doing so on Earth are marginal, at best.

Fully automating the mechanical excavation and loading of broken rock is likely to result in drastic productivity losses. It is well established that the productivity of virtually all excavation and loading equipment is highly sensitive to the expertise of the operator. Human judgment and fast response to seemingly minor aspects of rock loading operations are significant production and safety factors. Of particular concern in this context is that misjudgment by an operator can result in serious, even disastrous, consequences, such as cables breaking and machines overturning. Control engineering will have to preclude such occurrences as well as assure a reasonable production level.

The importance of human judgment in excavation technologies suggests a number of avenues for research aimed at identifying candidates for automation and nonterrestrial application. Questions that can be raised include the following: Will the implementation of automatic operation be most difficult for equipment that is most sensitive to operator handling? Should automation be preferentially applied to excavation technologies that are robust or insensitive to operator errors? What tradeoffs are

acceptable between automatic control and productivity?

To allow automation, operations should be as simple as possible. This fact, explicitly recognized in the space program (e.g., Firschein et al. 1986, p. 103), unquestionably underlies the mining industry's reluctance even to attempt to automate most excavation methods. The few notable exceptions (longwall mining, tunnel boring) for which automation is being investigated are already fully mechanized (involve minimal human intervention during normal operations). These exceptions tend to be high-production systems. They are prone to frequent breakdown and require preventive maintenance. Maintenance is recognized as a major difficulty in implementing automation (e.g., Firschein et al. 1986, p. 355); it will require major developments in artificial intelligence software and robotics. The need for human reasoning capability is again apparent.

12. The influence of gravity on slusher mining

Gertsch identifies slusher mining as one of the more promising lunar mining methods. The performance of a slusher on the lunar surface (or in underground operations on the Moon) will be affected by the low gravity.

The lighter weight of the scraper (bucket) on the Moon may lower the loading efficiency of the slusher bucket, because the weight influences the vertical penetrating force into the material to be loaded. Conversely, the lighter weight lunar material may flow more easily up into the bucket. It is conceivable that artificial weighting down of the bucket, or a reconfiguration of the cable force system, might be required in order to assure adequate penetration into the lunar soil and to avoid riding of the (empty or partially filled) bucket over the material to be loaded. Conversely, friction, abrasive wear, and power requirements during both inhaul and outhaul may be significantly reduced by the low gravity.

The reduced effective weight of the bucket, which is likely to have a detrimental impact on the efficiency of the all-important bucket-loading phase, might also adversely affect the performance of the bucket as it is hauled in to the unloading point. Assuming a relatively rough and bumpy ride during inhaul, the bucket may not retain its full load. An analysis might suggest a reduction in hauling speed, but this might also affect production adversely. It is possible that bucket redesign and cable reconfiguration might compensate at least partially for the reduced effective bucket weight.

Given the interest by this group in the application of slusher mining to the lunar program, it may be appropriate to outline in some detail steps that could be taken to reduce the need for speculation about the performance of such systems on the Moon.

Obtaining a clear understanding of the mechanics of bucket loading would be a desirable step. This step could be initiated with a comprehensive literature survey. It is unlikely that much fundamental information is available about slusher bucket mechanics, but considerable analysis has been made of the mechanics of similar excavation elements, such as dragline buckets, bulldozer blades, front-end loader buckets, and scrapers. Integrating this knowledge in a framework emphasizing the mechanical differences between terrestrial operating conditions and lunar operating conditions would go a long way towards identifying potential problems. Such an integrating effort should be made by a group with a clear understanding of the fundamental mechanics of the machine (bucket) and material (broken rock). At a minimum, meetings should be organized with experienced bucket designers from various manufacturers. In order to obtain maximum contributions from such personnel, it may be preferable to formally contract for their technical services. Equally important would

be information exchanges with operators; e.g., by means of visits to mines.

On the basis of the initial analyses, it should be possible to make preliminary estimates of the influence of gravity on bucket loading performance. This information could in turn form the basis for designing experiments (for example, experiments using centrifuges) to verify the analyses. Similarly, it may be possible to instrument buckets and their cables and chains in order to obtain a better understanding of the distribution of forces during loading. An appropriate iterative sequence of bucket analyses, experiments, and design modifications should provide a considerably improved understanding of bucket mechanics, ultimately leading to adequate bucket designs for drastically different operating conditions.

While I have emphasized slusher bucket development, I should point out that any studies of this type, aimed at an improved understanding of the mechanics of loading broken rock, will be beneficial for eventual redesign of other systems that might be considered for nonterrestrial loading operations. These would include hydraulic excavators, electric shovels, front-end loaders, bulldozers, scrapers, draglines, and clamshells.

13. Wear-resistant materials for space mining applications

Equipment maintenance is one of the most expensive and time-consuming (in terms of production delay) aspects of mining operations. The most critical maintenance aspect of all excavation equipment is the wear rate of excavation elements (e.g., buckets, their teeth, drag cables). Similarly, components of equipment for haulage and for crushing and grinding, which are subject to repeated impact and abrasion, may require frequent resurfacing or replacement. Replacement schedules and parts requirements need to be estimated in order to develop realistic life-cycle cost estimates. If wear parts had to be provided from Earth and if conventional replacement schedules needed to be maintained, the transportation requirements of nonterrestrial mining would be considerable.

It is virtually certain that the thermal environment, with its extremes of cold and hot, will significantly increase the wear on some components. Less certain, but nevertheless possible, is that increased friction due to the vacuum environment (Karafiath and Nowatzki 1978, p. 130) may contribute to accelerated frictional wear.

Wear components, especially excavation components, tend to be made of very heavy steel

alloys. Assuming that in parallel with lunar mining will proceed in situ manufacturing [including production of metals (Ehrlicke 1983)], it may be worthwhile to consider tradeoffs between transporting high-quality wear parts and producing lower quality wear parts locally.

14. Remote sensing of rock excavation characteristics

The potential of remote sensing to characterize the lunar surface for equipment mobility has been mentioned by Karafiath and Nowatzki (1978, p. 492). The significant impact vehicle traction may have on mining operations has been discussed under topic 8. With respect to mining itself, whether excavating hard rock or scooping up and loading soil, remote sensing will be equally important in determining strength, particle shape and size, interparticle friction, and other excavation parameters. While a final assessment of excavation feasibility will almost certainly require direct physical access, it is clear that remote sensing should be used to the greatest possible extent in determining excavation characteristics of possible mining sites. The importance of remote sensing obviously is well established in the space program, but we should note that interpretation in terms of minability may pose some unusual requirements.

15. Particle size reduction technology for applications in space

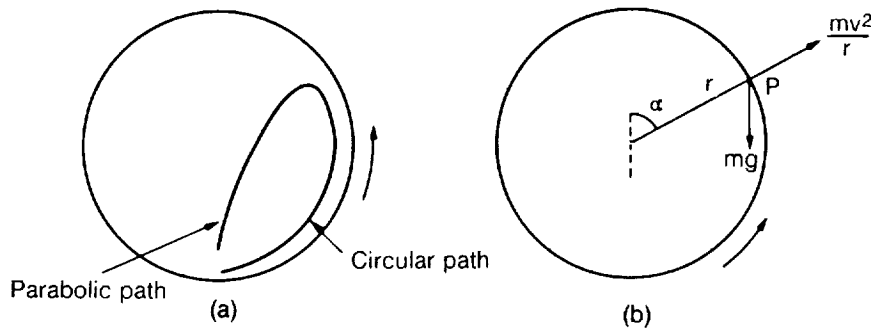

Mechanical reduction of particle size is usually not considered part of the mining cycle. It immediately follows the mining cycle, however, and optimizing the total sequence works better than optimizing the mining and milling operations separately.

Crushing is typically the first step in reducing the size of the mined rock. Most crushing systems depend on gravity feed and flow (Wills 1985, ch. 6). Gravity directly affects fragmentation in some systems (Mutz 1978). Its influence may not be fully appreciated in others, as it has never been considered a significant variable. The forces acting on particles during crushing in a low-gravity environment will differ markedly from the forces operating in conventional situations. It appears likely that crusher geometries

(e.g., jaws, cones, throats) might need to be modified for operations in an environment with drastically reduced gravity or that throughput rates might require considerable adjustment. Increased frictional force components may be beneficial in some crushing systems (Wills 1985, p. 169) but could be detrimental in others.

Grinding particles, either dry or submerged in liquids (Austin, Klimpel, and Luchie 1984; Wills 1985, ch. 7), is usually the final particle size reduction step. It is not obvious how significant the effects on grinding of a low-gravity, high-vacuum environment may be. In the most widely used tumbling mills, particle size reduction is accomplished primarily by impact. Gravity forces enter very explicitly into the design of these tumbling mills (Wills 1985, p. 186). Hence,

Tumbling Mill Action

a. Trajectory of the Grinding Medium in a Tumbling Mill

b. Forces Acting on Particles in a Tumbling Mill

Tumbling mills are widely used to reduce the size of broken rock particles. A particle being lifted up the shell of the mill will abandon its circular path for a parabolic path at point P, where the weight of the particle is just balanced by the centrifugal force; i.e., where

$$mg \cos \alpha = \frac{mv^2}{r}$$

This illustration of the forces acting on a particle clearly shows why gravity will affect grinding.

From Wills 1985, p. 186.

an analysis of gravitational effects should be straightforward. Such an analysis would be worthwhile because it addresses the most energy-consuming aspect, by far, of size reduction operations. Wet grinding, almost always preferred, clearly would pose problems in logistics (delivering or producing the liquid) and in containing and recovering the liquid.

Particle size classification is an important control procedure applied throughout the milling sequence. Most sizing methods depend on gravity to some extent. The final fine particle size classification most commonly is accomplished by differential settling in liquids, a method that would pose the same problems for space mining as would wet grinding.

The milling operations discussed here deserve consideration along with mining methods in order to optimize the entire sequence. Such an integrated optimization may shift the degree of fragmentation desired from the mining portion of the operation. The desired fragmentation may affect excavation, loading, and hauling.

Conclusions

The applicability of conventional mining technology to space mining can currently be evaluated only

on the basis of judgment and speculation. I have presented a list of research topics that correspond to information needs which must be answered in order to put such evaluations on a firmer basis. In many areas, relatively simple analyses of the mechanics of the system and of the impacts on it of gravity, atmosphere, and temperature could add quantitative understanding of the operation of terrestrial mining technologies in nonterrestrial environments. Iterative interactions between space engineers and scientists on the one hand, mining engineers on the other, and the integrating researchers performing the analyses should assure that the investigations stay correctly focused. Such investigations could be of considerable benefit to the mining industry, and this terrestrial technology transfer aspect deserves specific recognition.

I have given examples of conventional mining technologies which might be adapted to nonterrestrial applications, as well as examples of technologies that have not found practical applications on Earth. I propose that two approaches be pursued in parallel: one starting from available technology and identifying needed adaptations; the second starting from likely ultimate objectives and developing solutions unencumbered by conventional practice and thinking.

References

- Atkinson, T.; M. D. Waller; and B. Denby. 1987. Future Concepts in Surface Mining Operations. *Trans. Instn. Min. Metall.* **96** (April): A51-A62.
- Austin, L. G.; R. R. Klimpel; and P. T. Luchie. 1984. *Process Engineering of Size Reduction: Ball Milling*. New York: Society of Mining Engineers of AIME.
- Coal Age* **92** (1987), no. 8, p. 61. Cerchar Controls Shearer 400 km from Operator.
- Ehricke, K. A. 1983. Profitability of Manufacturing in Space in View of Lunar Industrial Development and Geo-Socio-Economic Benefits. In *Manufacturing in Space*, ed. L. Kops, PED Vol. 11, pp. 183-198. New York: American Soc. Mech. Eng., Production Engineering Division.
- Firschein, Oscar, et al. 1986. *Artificial Intelligence for Space Station Automation*. Park Ridge, NJ: Noyes Publications.
- Glaser, P. E. 1983. Rationale for Commercial Activities in Space. In *Manufacturing in Space*, ed. L. Kops, PED Vol. 11, pp. 143-148. New York: American Soc. Mech. Eng., Production Engineering Division.
- Hanold, R. J., compiler. 1977. *Rapid Excavation by Rock Melting—LASL Subterrene Program—September 1973/June 1976*. LA-5979-SR (Status Report). Los Alamos Scientific Laboratory, Feb.
- Hettiaratchi, D. R. P., and A. R. Reece. 1974. The Calculation of Passive Soil Resistance. *Geotechnique* **24** (3): 289-310.
- Hopkins, John L. 1987. Underground Revolution—Automation Update, Future Goals. *Canadian Mining J.* **108** (8): 29-38.
- Karafiath, Leslie L. 1970a. Friction Between Solids and Simulated Lunar Soils in Ultrahigh Vacuum and Its Significance for the Design of Lunar Roving Vehicles. Paper 16 in *Proc. Space Simulation Conf.*, National Bureau of Standards Special Publication 336, pp. 225-244. Gaithersburg, MD.
- Karafiath, L. L. 1970b. Analysis of Stress Distribution Beneath Wheels by the Theory of Plasticity with Respect to Lunar Locomotion. *Proc. ISTVS [Int. Soc. for Terrain Vehicle Systems]-TRW [Systems Group] Off-Road Mobility Symp.*, Nov. 3-4, Los Angeles.

Karafiath, Leslie L., and Edward A. Nowatzki. 1978. Soil Mechanics for Off-Road Vehicle Engineering. Trans Tech Publications Series on Rock and Soil Mechanics, Vol. 2, No. 5. Clausthal, Germany.

Kring, C. T.; J. N. Herndon; and S. A. Meacham. 1987. Potential Applications of Advanced Remote Handling and Maintenance Technology to Future Waste Handling Facilities. In Waste Management '87 (Proc. Symp. Waste Management, Tucson, Mar. 1-5), ed. Roy G. Post, vol. 2, pp. 529-534.

Kwitowski, A. J.; W. H. Lewis; W. D. Mayercheck; and M. C. Leigh. 1988. Computer-Based Remote Control of a Highwall Mining System. In 21st Century Higher Production Coal Mining Systems Symp., 232-241. Wollongong, New South Wales, Australia.

Maurer, William C. 1980. Advanced Drilling Techniques. Tulsa, OK: Petroleum Publishing Co. In this book Maurer quotes his own paper Spark Drilling, which appeared in 1970 as ch. 33, pp. 687-703, of Rock Mechanics—Theory and Practice, ed. W. H. Somerton, the record of the 11th (1969) Symp. on Rock Mechanics (New York: Society of Mining Engineers of AIME).

Motz, Jerome C. 1978. Crushing. Ch. 11 in Mineral Processing Plant Design, ed. A. L. Mular and R. B. Bhappu, 203-238. New York: Society of Mining Engineers of AIME.

Neudecker, J. W.; A. G. Giger; and P. E. Armstrong. 1973. Design and Development of Prototype Universal Extruding Subterranean Penetrators. LA-5205-MS (Manuscript Series). Los Alamos Scientific Laboratory.

Nowatzki, Edward A. 1972. The Effect of a Thermal and Ultrahigh Vacuum Environment on the Strength of Precompressed Granular Materials. The Moon 5 (1 & 2): 31-40.

Rowley, John C. 1974. Rock Melting Applied to Excavation and Tunneling. In Advances in Rock Mechanics (3rd Congress Int. Soc. Rock Mechanics), Vol. II, Part B, pp. 1447-1453. Washington, DC: Nat. Acad. Sci.

Scales, Marilyn. 1987. HDRK Seeks Truly Continuous Technology. Canadian Mining J. 108 (8): 39.

Sims, D. L. 1973. Identification of Potential Applications for Rock-Melting Subterrenes. LA-5206-MS (Manuscript Series). Los Alamos Scientific Laboratory, Feb.

Stricklin, Kevin G. 1987. Current Usage of Continuous Monitoring Systems in Coal Mines. *Mining Engineering* **39** (7): 859-863.

Stuart, D. G. 1983. Automation, Robotics, and Machine Intelligence Systems (ARAMIS) in Space Manufacturing. In *Manufacturing in Space*, ed. L. Kops, PED Vol. 11, pp. 113-126. New York: American Soc. Mech. Eng., Production Engineering Division.

Thirumalai, K.; S. G. Demou; and R. L. Fischer. 1975. Thermomechanical Method for Secondary Breakage of Hard Rocks, Bureau of Mines Report of Investigations RI 8057. Washington, DC: U.S. Department of the Interior.

Wagner-Bartak, C. G.; P. S. Matthews; and B. R. Hill. 1983. Remote Manipulators in Space. In *Manufacturing in Space*, ed. L. Kops, PED Vol. 11, pp. 101-112. New York: American Soc. Mech. Eng., Production Engineering Division.

Williamson, Ray A. 1985. The Industrialization of Space—Prospects and Barriers. Ch. 5 in *the Exploitation of Space*, ed. M. Schwartz and P. Stares, 64-76. London: Butterworths.

Wills, B. A. 1985. *Mineral Processing Technology*, 3rd ed. Oxford, England: Pergamon Press.