

longer times for sample analyses. Early tests with these sources would be very desirable. Additional work with HgI₂ detectors and their performance under lunar conditions (e.g., high temperatures) will also have to be investigated.

References: [1] Economou T. E. and Turkevich A. L. (1976) *Nucl. Instr. Meth.*, 134, 391-400. [2] Franzgrote E. J. et al. (1970) *Science* 167, 376-379.

N93-17244 1993008055

HIGH-RESOLUTION ELEMENTAL MAPPING OF THE LUNAR SURFACE. Bradley C. Edwards, Frank Ameduri, Jeffrey J. Bloch, William C. Priedhorsky, Diane Roussel-Dupré, and Barham W. Smith, Los Alamos National Laboratory, Los Alamos NM 87545, USA.

New instruments and missions are being proposed to study the lunar surface as a result of the resurgence of interest in returning to the Moon. One instrument recently proposed is similar in concept to the X-ray fluorescence detectors flown on Apollo, but utilizes fluorescence from the L- and M-shells rather than the K-shell. This soft X-Ray Fluorescence Imager (XRFI) will be the topic of this presentation.

As was proven by the Apollo missions, the elemental composition of the lunar surface can be mapped using X-ray fluorescence from lunar orbit [1,2]. However, the spatial resolution and precision of the Apollo experiments were limited by both exposure time and flux. Although future missions will have longer lifetimes, the flux for K-shell fluorescence is still a primary limiting factor and imaging keV radiation with a wide field of view is difficult. However, the L- and M-shell fluorescence may provide a solution because the much more intense solar radiation at less than 1 keV will make the lower energy fluorescence flux up to 10⁴ times more intense.

The theory behind the XRFI was discussed recently in Edwards et al. [3] and indicates that the fluorescent emission should be intense enough to be observed from lunar and even Earth orbit. Preliminary concepts and designs have been worked out for an XRFI that could be flown in lunar orbit in three years. XRFI is one in the suite of instruments on the Lunar Resource Mapping mission. The proposed instrument will provide maps with high

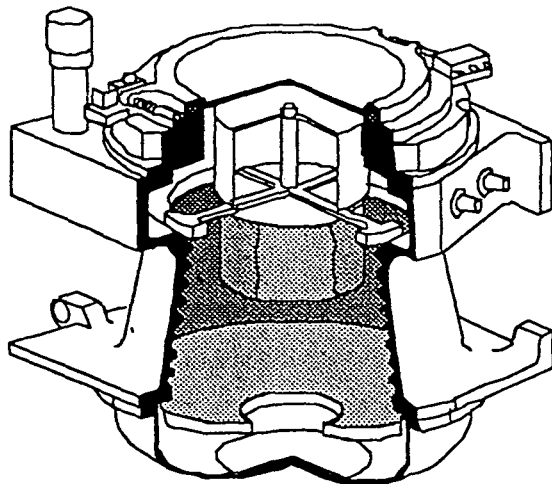

Fig. 1. Diagram of current ALEXIS telescope design. A similar design is to be used for the XRFI instrument on the LRM mission.

spatial resolution (1 km) of the surface distribution of a valuable suite of elements (Al, Mg, Si, Ca, Na, Fe, Ti, etc.).

Although this design is not ideal for the lunar study, optimized instruments with improved capabilities are only in the conceptual stage and may not be feasible for many years.

The XRFI set of soft X-ray telescopes would fly in lunar orbit to observe the fluorescent emission. The telescopes are of the same design to be used on the ALEXIS mission with a normal incidence multilayer mirror, a microchannel plate detector, and thin film filters. The technology, facilities, and software developed and tested for ALEXIS are to be directly applied to the XRFI.

Each telescope would be tuned to an energy that corresponds to an L- or M-shell fluorescent line. The intensity of each line is proportional to the elemental abundance, surface structure, and incident solar flux level. Details of the instrument, its requirements, specifications, and limitations will be presented.

Results from current feasibility studies of the XRFI concept being done at Brookhaven will be discussed and presented along with their implications. Future plans for studies, design, and construction of the XRFI and the lunar community's involvement is also a planned topic for this presentation.

Acknowledgments: We would like to thank D. Vaniman and G. Heiken for helpful discussions concerning the lunar surface. This work was completed under the auspices of DOE.

References: [1] Adler I. et al. (1972) *Proc. LSC 3rd*, 2157-2178. [2] Adler I. et al. (1975) *Space Science Instrumentation*, 1, 305-315, Reidel. [3] Edwards B. C. et al. (1991) *GRL*, 18, 2161-2164.

N93-17245 1993008056

LUNAR AND ASTEROID COMPOSITION USING A REMOTE SECONDARY ION MASS SPECTROMETER. R. C. Elphic, H. O. Funsten, B. L. Barraclough, D. J. McComas, and J. E. Nordholt, Space Plasma Physics Group, Los Alamos National Laboratory, Los Alamos NM 87545, USA.

Laboratory experiments simulating solar wind sputtering of lunar surface materials have shown that solar wind protons sputter secondary ions in sufficient numbers to be measured from low-altitude lunar orbit. Secondary ions of Na, Mg, Al, Si, K, Ca, Mn, Ti, and Fe have been observed sputtered from sample simulants of mare and highland soils [1]. While solar wind ions are hundreds of times less efficient than those used in standard secondary ion mass spectrometry, secondary ion fluxes expected at the Moon under normal solar wind conditions range from ~10 to >10⁴ ions cm⁻² s⁻¹, depending on species. These secondary ion fluxes depend both on concentration in the soil and on probability of ionization; yields of easily ionized elements such as K and Na are relatively much greater than those for the more electronegative elements and compounds. Once these ions leave the surface, they are subject to acceleration by local electric and magnetic fields. For typical solar wind conditions, secondary ions can be accelerated to an orbital observing location. The same is true for atmospheric atoms and molecules that are photoionized by solar EUV. Here we discuss the instrumentation to detect, identify, and map secondary ions sputtered from the lunar surface and photoions arising from the tenuous atmosphere.

Solar Wind-sputtered Secondary Ions and Surface Composition: Our laboratory experiments subjected three simulants of Apollo soil samples to ion bombardment, and measured the relative efficiencies of solar wind ions in sputtering secondary ions. The

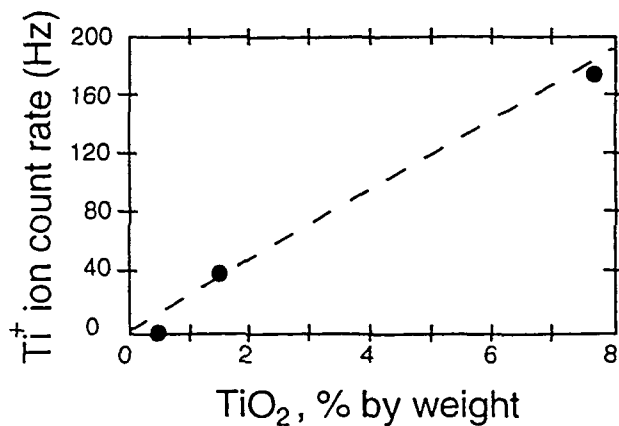

Fig. 1. Intensity of secondary Ti^+ ions sputtered by 1.5-keV H^+ vs. bulk TiO_2 measured by electron microprobe.

simulants were replications of an Apollo 11 high-Ti mare basalt soil, an Apollo 15 low-Ti mare basalt soil, and an Apollo 16 aluminous highland soil. They were left in rocky, not powdered form. These simulants were subjected to bombardment by Ar and Ne ions at 5-keV energies, and the solar-wind-like ions of H and He at 1.5- and 4-keV energies respectively. The very different nuclear stopping powers of these ions in the target materials allowed us to study the relative sputtering efficiencies. Ar⁺ at 5 keV, with its much larger nuclear stopping power, is about a factor of 400 more efficient than 1.5-keV H^+ in sputtering secondary ions. The major geochemical elements Na, Mg, Al, Si, K, Ca, Ti, Mn, and Fe are nevertheless detectable.

While we have a first-order understanding of secondary ion sputtering, it is not immediately obvious that the observed ion yields can be linked with great accuracy to the simulants' composition. The simulants were analyzed by electron microprobe to establish their detailed composition. The observed secondary ion fluxes can then be compared with the microprobe results. One example is shown in Fig. 1, where observed Ti^+ fluxes from the three simulants are plotted vs. the weight percent of TiO_2 . The results show that the sputtered Ti^+ secondary ions correspond to the true composition with accuracies of better than 10% for the high-Ti basalt, and about 20% for the low-Ti simulant. The highland simulant produced a statistically insignificant Ti^+ count rate. Similar but poorer results were obtained for the elements Al, Fe, Ca, and K. The response of Mg ions did not correlate well with composition under any circumstances. Sodium content did not vary enough between samples to do the comparison. We believe the cause of this poor correlation is that sputtered materials redeposited on adjacent surfaces (all three simulants were in the same vacuum chamber). This led to cross contamination between the samples. In the future we intend to redo the experiment one sample at a time to prevent this problem.

The relative total secondary ion yields sputtered by Ar, Ne, and He demonstrate a well-behaved exponential dependence on nuclear stopping power. However, the 1.5-keV H^+ yield is about an order of magnitude larger than predicted; H is a more efficient sputterer than one might expect. Yields of the various constituents of the simulants depend upon both the elemental concentration and ionization potential of the species, or alternatively its electronegativity. This dependence of positive secondary ion yield on ionization potential was suggested first by Anderson and Hinthorne

[2]. In addition, it should be remembered that the secondary ion yields from regoliths are less than that from solid rocky targets [3].

Once the secondary ions are ejected from a surface grain, they are subject to ambient electric and magnetic fields. Sunlit surfaces emit photoelectrons and, up to about 80° solar zenith angle, are positively charged; shadowed regions may become negatively charged to -100 V. In most sunlit regions the secondary ions will be accelerated away from the surface by the positive surface charge; the influence of this field extends out one or two Debye lengths, typically a few meters. Thereafter, the ions are exposed to the solar wind $V \times B$ electric field, which normally points approximately toward either ecliptic north or south. For typical conditions, this electric field is so intense it dominates the secondary ion equation of motion, and the ions simply "fall" along the electric field lines. Figure 2 shows several characteristic ion trajectories in typical solar wind conditions. However, in regions of remnant magnetism on the lunar surface, local magnetic field intensities may (1) deflect and decelerate the incoming solar wind and (2) may trap the sputtered secondary ions [4]. Nevertheless, these high surface field regions are limited to 10-30-km size scales, about the size of an ion mass spectrometer "pixel" from a 100-km orbit. Moreover, even secondary ions that are locally trapped may drift to weaker field regions where they can be picked up by the solar wind electric field. Quantitative simulations of secondary ions in remnant fields confirm this escape scenario.

Detection and Mapping of Outgassed Volatiles: In addition to detecting sputtered secondary ions from the lunar surface, a high-sensitivity, high-mass-resolution orbital ion mass spectrometer can detect and map atmospheric ions. The ion mass spectrometers placed on the lunar surface during Apollo proved that this measurement can be made. The known atmospheric constituents include Ne, Ar, Na, and K; other species are likely. Apollo surface atmospheric measurements showed a high correlation of global atmospheric Ar content with deep lunar seismic activity; increases in the Ar density followed every moonquake. The relationship between deep seismics and volatile venting is not understood. Moreover, arguments based on the Apollo alpha spectrometer measurements of radon (cf. [5]) suggest that volatile transport from subsurface reservoirs can on occasion be substantial. It is important to measure episodic lunar volatile venting and establish those regions that are most active.

Atmospheric constituents that have been photoionized by solar EUV will be accelerated by the solar wind electric field in the same way as surface-sputtered ions. These photoions travel from their creation point along the electric field into the instrument. In this way an ion mass spectrometer can actually sound the atmospheric structure. More importantly, the instrument can detect atmospheric transients such as volatile venting episodes without actually being over the site of activity. The vented volatile atoms and molecules hop along the surface ballistically, random walking their way around the Moon; as this diffusive "wave" passes by the spacecraft, an increase in the flux of photoions produced nearby will be detected.

The 3-D Linear Electric Field Ion Mass Spectrometer: We discuss here the design of a secondary ion mass spectrometer that can be flown in lunar orbit or on an asteroid rendezvous mission. In order to map elemental composition of the Moon or asteroid, high sensitivities and high mass resolutions ($m/\Delta m \sim 50$ at FWHM) are necessary. A new design using a three-dimensional Linear Electric Field (LEF3D) time-of-flight spectrometer meets these

requirements. A similar design presently being developed for the Cassini mission is currently undergoing prototype testing.

Our mass-measuring technique, based on the motion of ions in a region of linear electric field (LEF), is quite simple. For a z -directed electric field $E_z(z)$ that increases linearly with distance along the axis, z , $E_z(z) = -kz$, where k is a constant solely dependent upon the electromechanical configuration of the device. Since the electrostatic force on a particle is qE , where q is the particle charge, the equation of motion for the particle in the z direction is that of a simple harmonic oscillator of mass m . A particle entering the LEF region at $z = 0$ will return to the $z = 0$ plane after completing half of an oscillation cycle, i.e., when $t = \pi/\omega = \pi(m/qk)^{1/2}$.

This timing is accomplished by passing the arriving ions through an ultrathin carbon foil; secondary electrons produced at the foil are accelerated in the LEF region to a detector that starts a timing clock. Positive ions emerging from the foil enter the LEF region and are reflected as described above, and are counted at a second detector that provides the stop signal for that ion's time of flight.

However, another feature of the mass spectrometer described here involves the analysis of molecular ion species. In addition to providing start timing pulses, the carbon foil also dissociates molecular ions. All ions are electrostatically energy-selected and arrive at the foil with a known energy/charge. Passing through the foil, it is dissociated into fragments that all travel with nearly the same velocity so that the energy is partitioned in proportion to the mass of each fragment. These fragments then have less E/q than the initial molecular value and will not travel as deeply into the LEF region of the device as would directly analyzed atomic ions of the same nominal E/q . Because of small E -field nonlinearities in an appropriately detuned LEF3D device, especially at the low-potential entrance end of the device, the times of flight of the fragments can be made shorter than those of atomic ions, an effect that allows separation of molecular and atomic interferences.

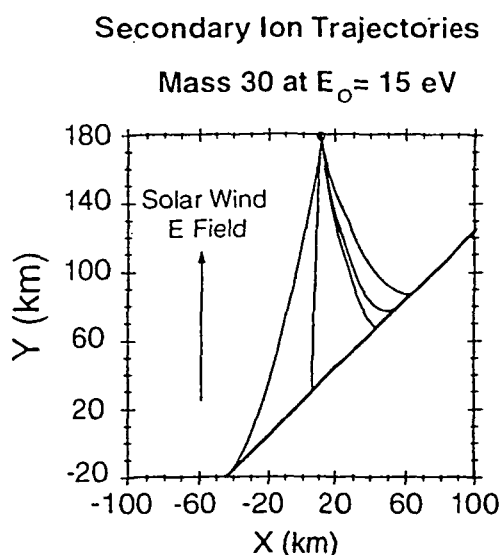

Fig. 2. Trajectories of sputtered secondary ions for typical solar wind conditions. Two representative paths illustrate how ions originating at different locations pass through a 100-km lunar orbit; the two ions are distinct in their arrival directions and their energies.

Finally, in addition to its orbital reconnaissance role, an LEF3D instrument can also perform surface composition measurements in conjunction with an active sounding technique. For example, ions produced by laser-induced breakdown of lunar materials would facilitate remote assessment of exposed materials not accessible to direct rover sampling, for example. An LEF3D instrument on a stationary landed platform would also provide synoptic monitoring of the atmosphere and volatile environment in conjunction with a geophysical station.

References: [1] Elphic R. C. et al. (1991) *GRL*, 18, 2165-2168. [2] Anderson C. A. and Hinthorne J. R. (1972) *Science*, 75, 853. [3] Hapke B. (1986) *Icarus*, 66, 270-279. [4] Hood L. L. and Williams C. R. (1989) *Proc. LPSC 19th*, 99-113. [5] Friesen L. J., this volume. [6] McComas D. J. et al. (1990) *Proc. Natl. Acad. Sci. USA*, 5925-5929.

1993008057
488009
N93-17246

LUNAR RESOURCE ASSESSMENT: AN INDUSTRY PERSPECTIVE. S. C. Feldman, B. H. Altenberg, and H. A. Franklin, Bechtel Corporation, P.O. Box 193965, San Francisco CA 94119, USA.

Introduction: The goals of the U.S. space program are to return to the Moon, establish a base, and continue onward to Mars. To accomplish this in a relatively short time frame and to avoid the high costs of transporting materials from the Earth, we will need to mine resources on the Moon. Oxygen will be one of the most important resources, to be used as a rocket propellant and for life support. Ilmenite and lunar regolith have both been considered as ores for the production of oxygen.

Resource production on the Moon will be a very important part of the U.S. space program. To produce resources we must explore to identify the location of ore or feedstock and calculate the surface and underground reserves. Preliminary resource production tests will provide the information that can be used in final plant design. Bechtel Corporation's experience in terrestrial engineering and construction has led to an interest in lunar resource assessment leading to the construction of production facilities on the Moon.

There is an intimate link between adequate resource assessment to define feedstock quantity and quality, material processing requirements, and the successful production of lunar oxygen. Although lunar resource assessment is often viewed as a research process, the engineering and production aspects are very important to consider. Resource production often requires the acquisition of different types, scales, or resolutions of data than that needed for research, and it is needed early in the exploration process. An adequate assessment of the grade, areal extent, and depth distribution of the resources is a prerequisite to mining. This paper emphasizes the need for a satisfactory resource exploration program using remote sensing techniques, field sampling, and chemical and physical analysis. These data can be used to define the ore for oxygen production and the mining, processing facilities, and equipment required.

Background: The lunar environment is harsh and the emplacement of production facilities and mining will not be simple. Adequate data gathered now will prevent costly errors later. There are special problems associated with the lunar environment and mining operations. Temperature fluctuations will cause materials to become brittle. Reduced gravity will affect material handling